

SECTION 1 GENERAL

Group 1 Safety Hints	1-1
Group 2 Specifications	1-10
Group 3 Operational Checkout Record Sheet	1-17

SECTION 2 ENGINE

Group 1 Structure and Function	2-1
Group 2 Engine Speed and Stall rpm	2-8

SECTION 3 POWER TRAIN SYSTEM

Group 1 Structure and Function	3-1
Group 2 Operational Checks and Troubleshooting	3-17
Group 3 Test and Adjustments	3-25
Group 4 Disassembly and Assembly	3-27

SECTION 4 BRAKE SYSTEM

Group 1 Structure and Function	4-1
Group 2 Operational Checks and Troubleshooting	4-7
Group 3 Tests and Adjustments	4-11

SECTION 5 STEERING SYSTEM

Group 1 Structure and Function	5-1
Group 2 Operational Checks and Troubleshooting	5-9
Group 3 Tests and Adjustments	5-16
Group 4 Disassembly and Assembly	5-23

SECTION 6 WORK EQUIPMENT

Group 1 Structure and Function	6-1
Group 2 Operational Checks and Troubleshooting	6-71
Group 3 Tests and Adjustments	6-84
Group 4 Disassembly and Assembly	6-96

CLICK HERE TO **DOWNLOAD** THE COMPLETE MANUAL

- Thank you very much for reading the preview of the manual.
- You can download the complete manual from: www.heydownloads.com by clicking the link below



- Please note: If there is no response to CLICKING the link, please download this PDF first and then click on it.

CLICK HERE TO **DOWNLOAD** THE COMPLETE MANUAL

SECTION 1 GENERAL

Group 1 Safety Hints	1-1
Group 2 Specifications	1-10
Group 3 Operational Checkout Record Sheet	1-17

GROUP 2 SPECIFICATION

1. MAJOR COMPONENT

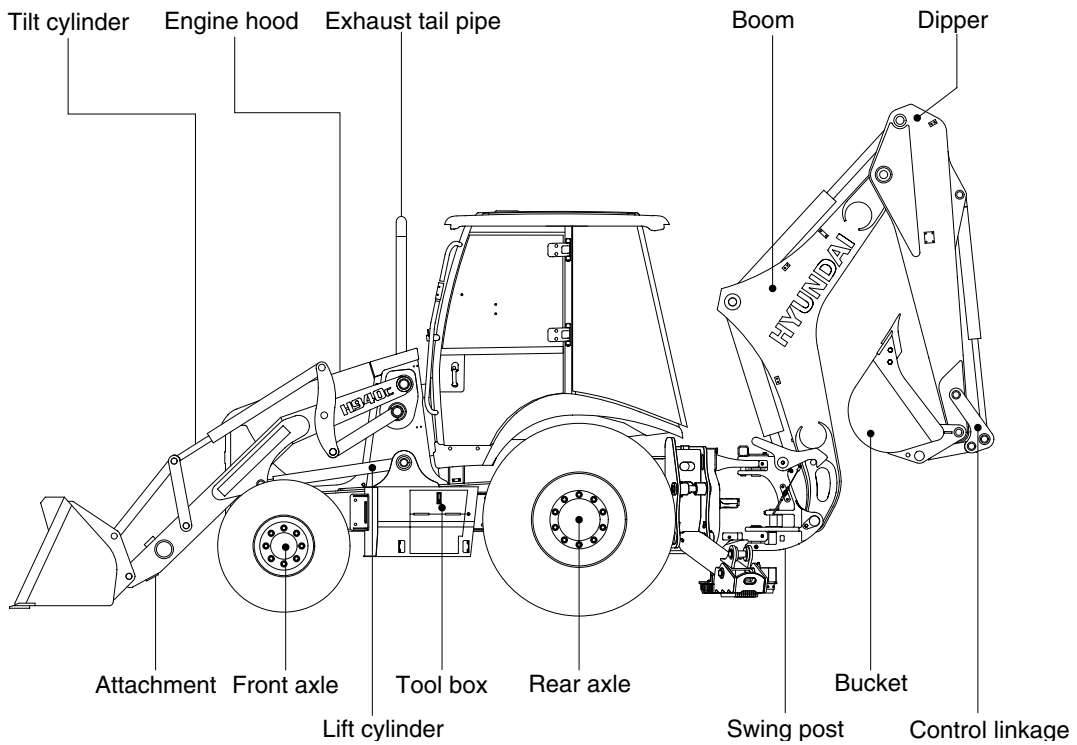
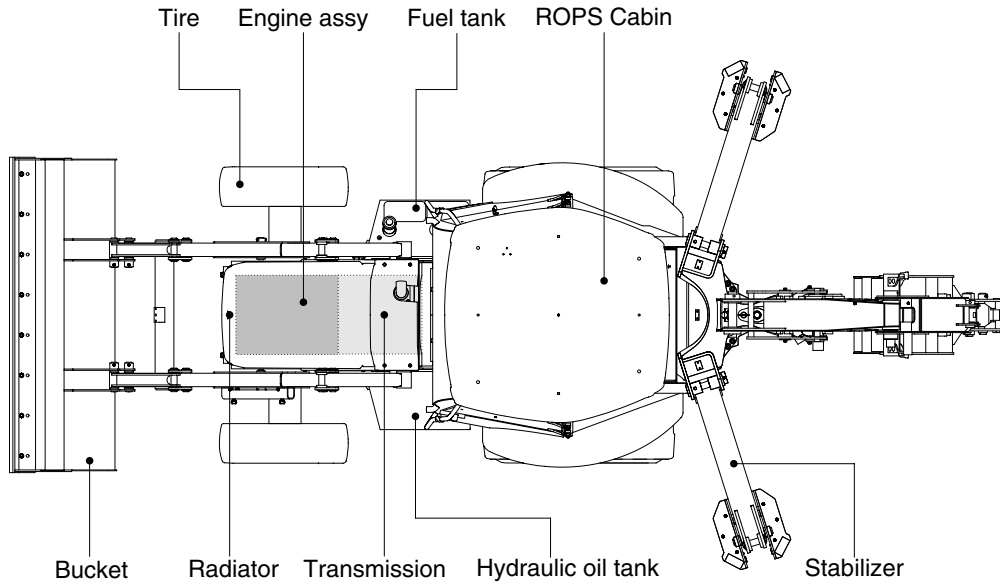

H940C2SP01

7. Steering system checks

- Steering unit check _____
- Steering system leakage check _____

8. Accessory checks

- Operating lights check _____
- Work light check _____
- Brake light check _____
- Cab light check _____
- Horn circuit check _____
- Windshield washer and wiper check _____
- Defroster blower check _____
- Heater/Air conditioner blower check _____
- Heater functional check _____
- Air conditioner functional check _____
- Start aid system check _____

9. Cab components and vandal protection checks

- Cab door latch check _____
- Cab door hold open latch check _____
- Cab door release button check _____
- Cab door lock check _____
- Cab door window check _____
- Cab window latch check _____
- Steering column adjustment check _____
- Seat and seat belt check _____
- Air intake filter door check _____
- Engine side panels check _____
- Radiator cap access door check _____
- Boom lock check _____
- Service decal check _____

STRUCTURE (2/2)

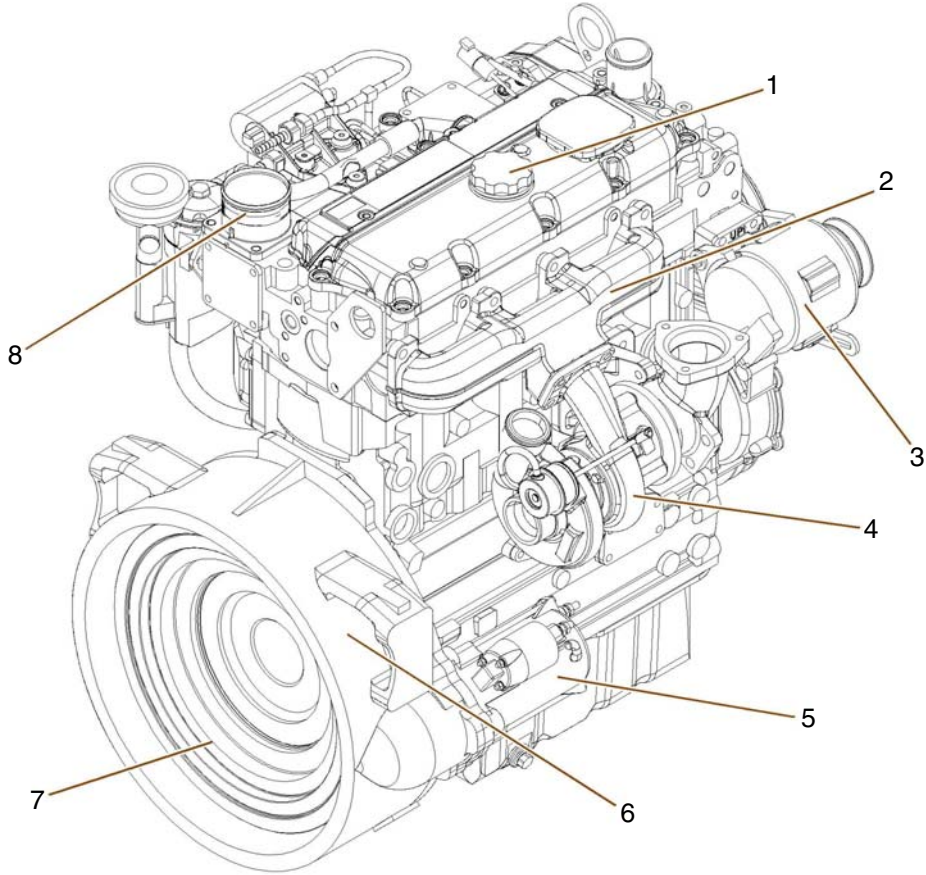

H940S2EG02

- | | | |
|--------------------|--------------------|--------------|
| 1 Oil filler cap | 4 Turbocharger | 7 Flywheel |
| 2 Exhaust manifold | 5 Start motor | 8 Air intake |
| 3 Alternator | 6 Flywheel housing | |

SECTION 3 POWER TRAIN SYSTEM

Group 1 Structure and Function	3-1
Group 2 Operational Checks and Troubleshooting	3-17
Group 3 Test and Adjustments	3-25
Group 4 Disassembly and Assembly	3-27

② Forward

In forward, forward clutch and K1, K2, K3, K4 clutch are engaged.

Forward clutch and K1, K2, K3, K4 clutch are actuated by the hydraulic pressure applied to the clutch piston.

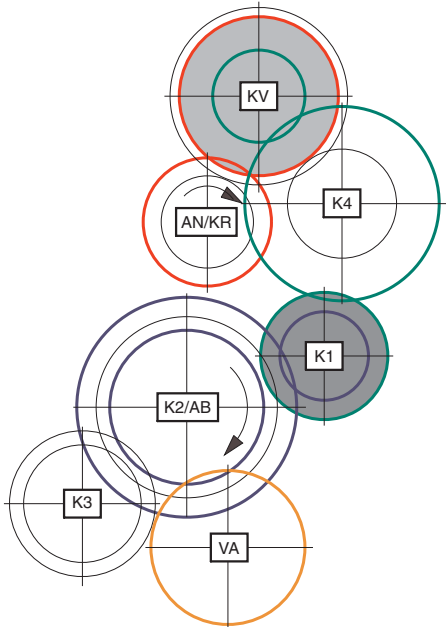

1st gear forward

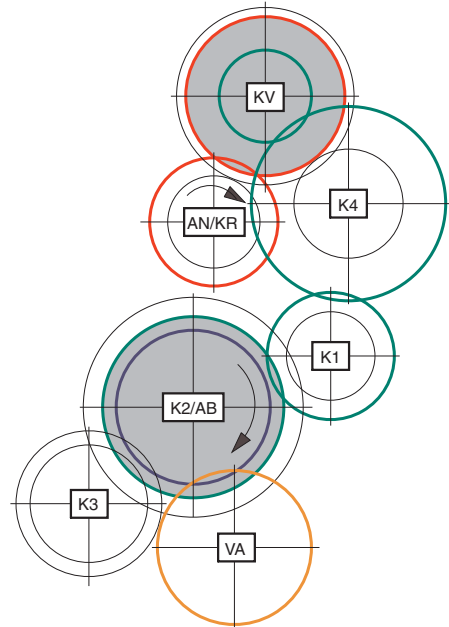

2nd gear forward

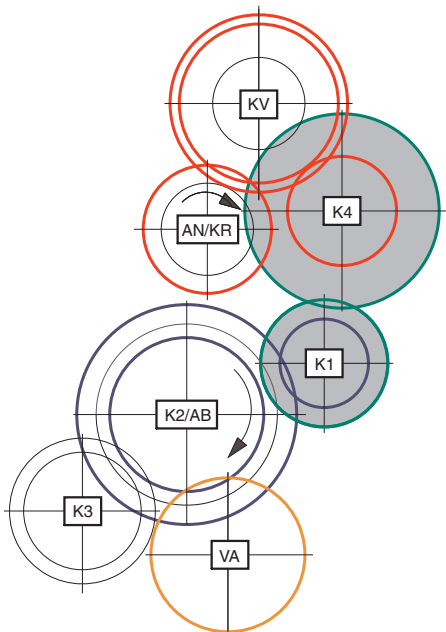

3rd gear forward

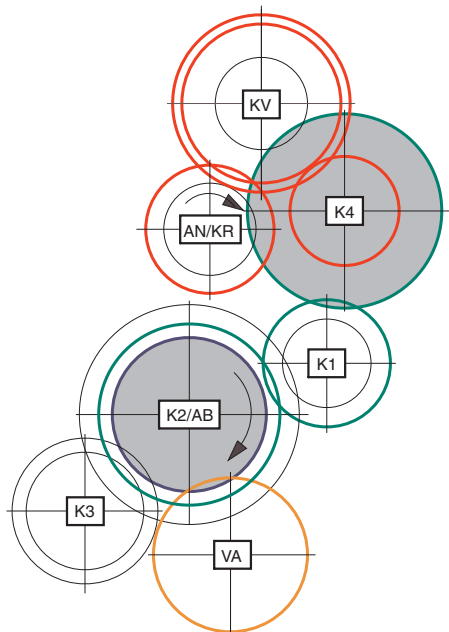

4th gear forward

HB100PT13

KR/AN = Clutch reverse/input
KV = Clutch forward
K1 = Clutch 1st speed

K2/AB = Clutch 2nd speed/output
K3 = Clutch 3rd speed
(4 wheel drive only)

K4 = Clutch 4th speed
VA = Front wheel drive
(4 wheel drive only)

2. TROUBLESHOOTING

1) TRANSMISSION

※ Diagnose malfunction charts are arranged from most probable and simplest to verify, to least likely, more difficult to verify. Remember the following steps when troubleshooting a problem :

Step 1. Operational check out procedure (See group 3 in section 1.)

Step 2. Operational checks (In this group.)

Step 3. Troubleshooting

Step 4. Tests and/or adjustments (See group 3.)

Problem	Cause	Remedy
Transmission slippage	<p>Low oil level.</p> <p>Wrong oil grade.</p> <p>Leak in transmission control valve or gasket.</p> <p>Low transmission pump flow due to worn pump.</p> <p>Weak or broken pressure regulating valve spring.</p>	<p>Add oil.</p> <p>Change oil.</p> <p>Remove valve and inspect gaskets.</p> <p>Do transmission pump flow test.</p> <p>Do transmission system pressure test.</p>
Machine will not move	<p>Low oil level.</p> <p>Applied park brake.</p> <p>Malfunctioning parking brake solenoid valve.</p> <p>Excessive leakage in transmission element.</p> <p>Worn clutch disks.</p> <p>Low or no transmission pressure.</p> <p>Service brake will not release.</p> <p>Failed torque converter.</p> <p>Broken shafts or gears.</p> <p>Broken drive shafts.</p>	<p>Add oil.</p> <p>Check parking brake fuse.</p> <p>Check continuity to parking brake switch.</p> <p>Remove and inspect parking brake solenoid valve.</p> <p>Check for power to solenoid valve.</p> <p>Do transmission element leakage test using system pressure.</p> <p>Repair transmission.</p> <p>See transmission pressure is low in this group.</p> <p>Do brake pedal operational check.</p> <p>Do service and park system drag checks.</p> <p>Do torque converter stall test.</p> <p>If engine pull down in normal, torque converter is good.</p> <p>Drain transmission to determine if large pieces of metal contamination are present.</p> <p>Inspect drive shafts and universal joints for external damage. Repair.</p>
Machine does not engage in low gear	<p>Malfunctioning transmission control solenoid valve.</p> <p>Stuck spool in transmission control valve.</p>	<p>Check solenoid valve.</p> <p>Remove and inspect transmission control valve spools.</p>

(2) Main pressure valve and converter safety valve

- ① Loosen screw plug (1) and remove main pressure valve (control pressure valve) :

Main pressure valve consists of:

- 1 = Screw plug
- 2 = O-ring
- 3 = Piston
- 4 = Spacer ring
- 5 = Compression spring

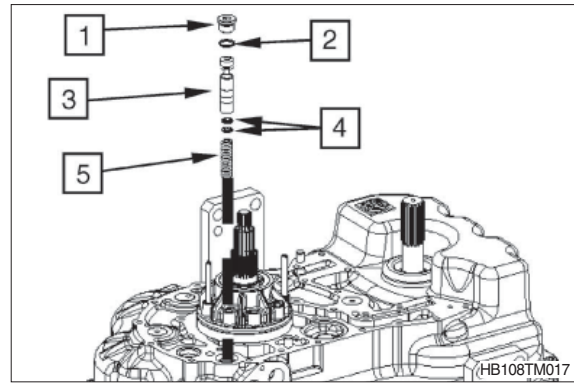

- ※ Functional check of converter safety valve (1).
Use a screwdriver to check the movability of the ball in the valve.
- ※ If the valve is o.k., it does not need to be removed.
- ※ Valve assy is installed in the housing-not visible.

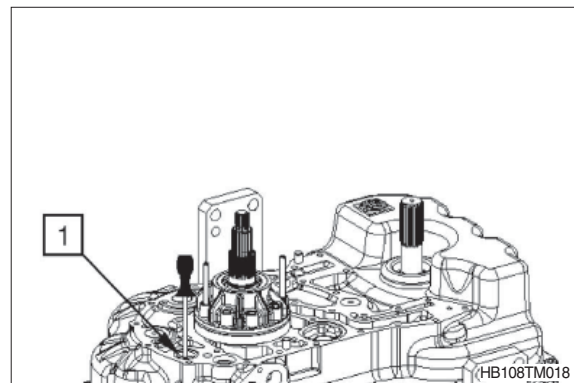

3) REMOVAL OF CLUTCHES, CENTRAL SHAFT AND DISASSEMBLY OF TRANSMISSION PUMP

(1) Removal of clutches

- ① Force out cylindrical pins (1).
Loosen bolted connection (2) of housing front and rear part.

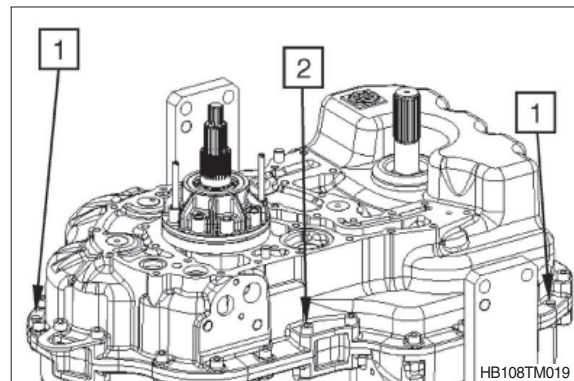

- ③ Remove bearing inner ring (1), axial bearing assy (2) and inner disk carrier (3).

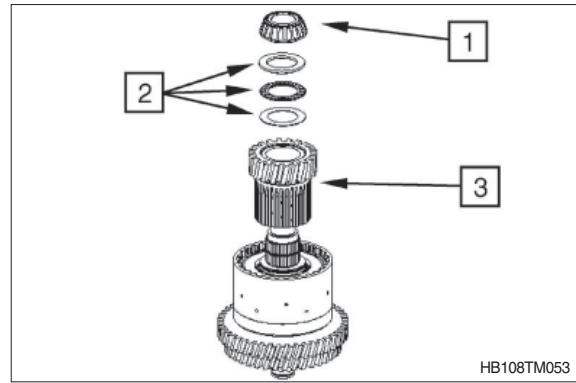

- ④ Remove needle cage (1).

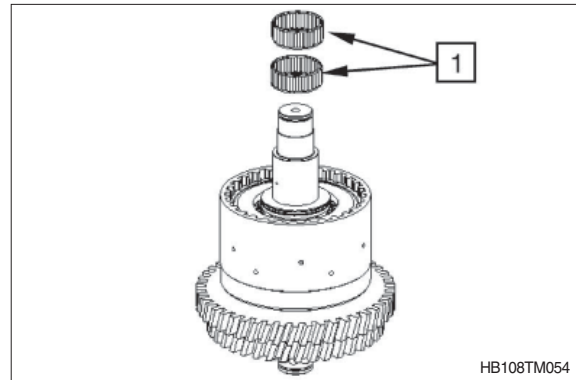

- ⑤ Remove axial bearing assy (1).

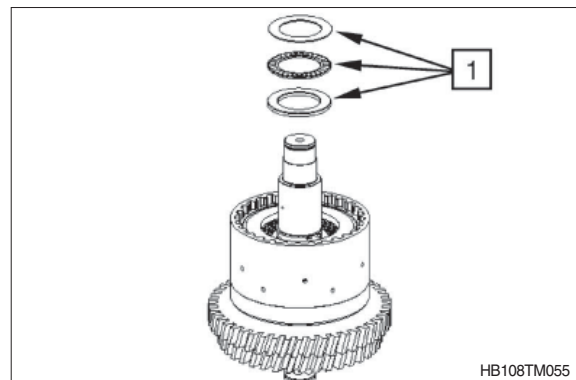

- ⑥ Remove snap ring (1).

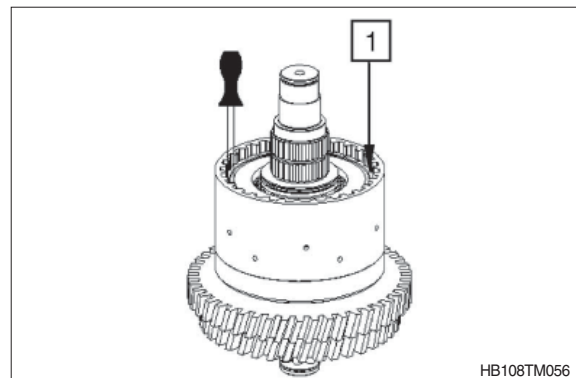

⑬ Snap out rectangular rings (1).

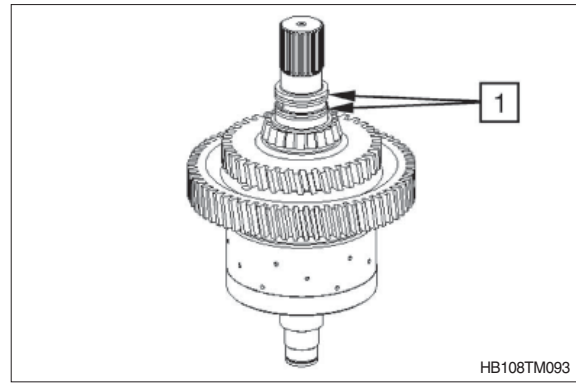

⑭ Pull tapered roller bearing (inner ring) off the shaft.

- (S) Grab sleeve 5873 001 026
- (S) Basic tool 5873 001 000

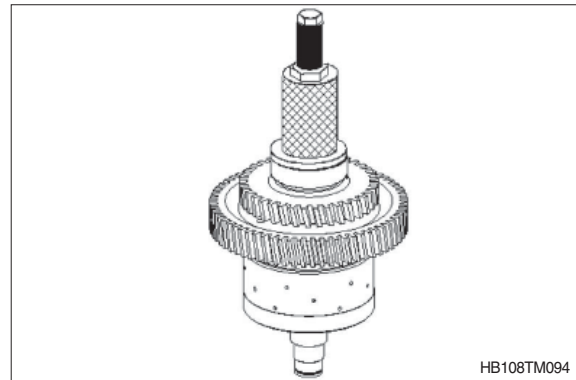

※ The clutch (1) cannot be disassembled.
It is supplied by the spare parts service only as a complete assy which consists of:

- 1A = Ball
- 1B = Helical gear
- 1C = Shaft
- 1D = Disk carrier

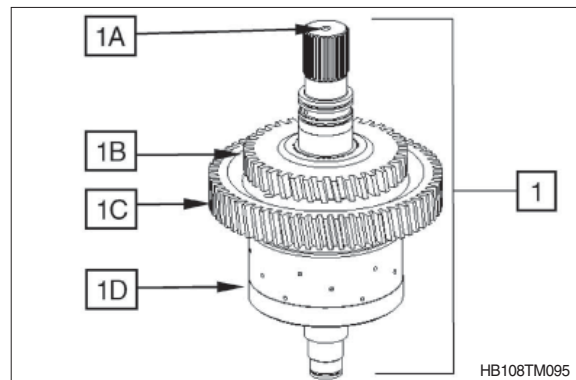

(5) K3 clutch

① Snap out rectangular ring (1).

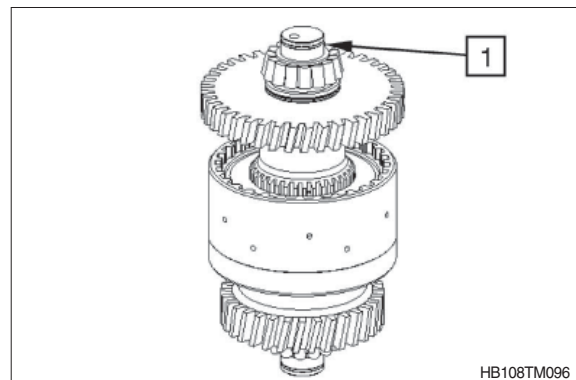

- ⑨ By means of compressed air (see arrow), press piston (1) off the shaft/disk carrier and remove it.

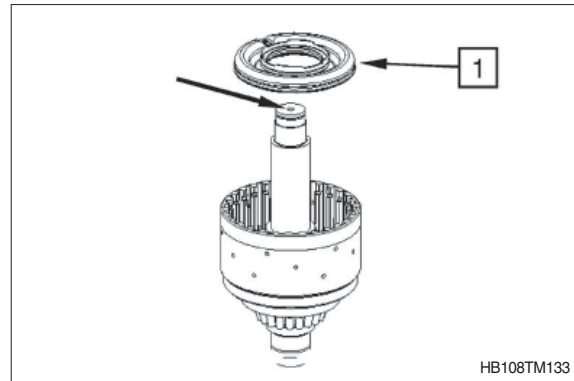

- ⑩ Pull tapered roller bearing (inner ring) off the shaft.

(S) Grab sleeve 5873 001 026
 (S) Basic tool 5873 001 000

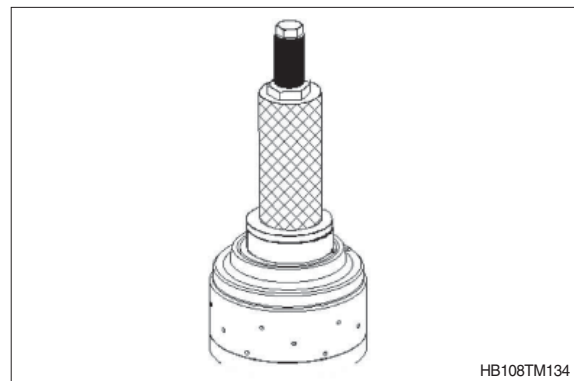

- ※ The clutch (1) cannot be disassembled. It is supplied by the spare parts service only as a complete assy which consists of:

1A = Shaft
 1B = Disk carrier

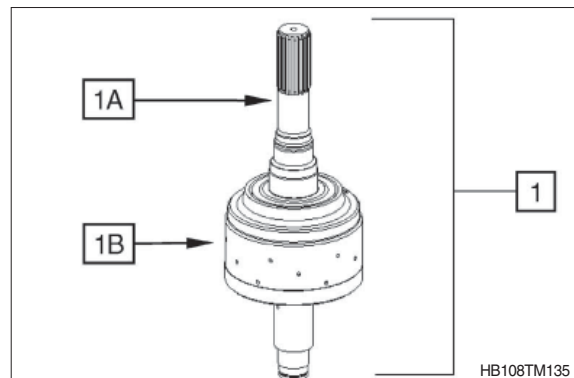

⑮ Snap retaining ring 40×1.75 (1) into the groove.

※ Contact for axial bearing - see the next figure ⑯.

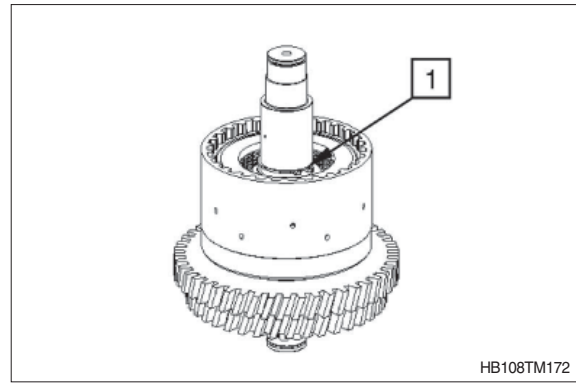

⑯ Mount running disk $40 \times 60 \times 3.5$ (1), axial needle cage $40 \times 60 \times 3$ (2) and axial washer $40 \times 60 \times 1$ (3) and oil them.

※ Mount running disk (1), with the chamfer showing towards the retaining ring.

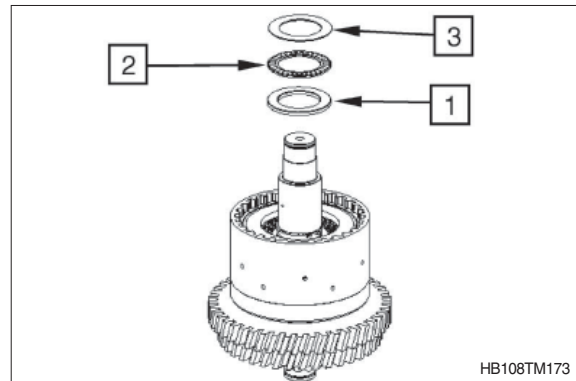

⑰ Mount needle cage $40 \times 45 \times 17$ (1) and oil it.

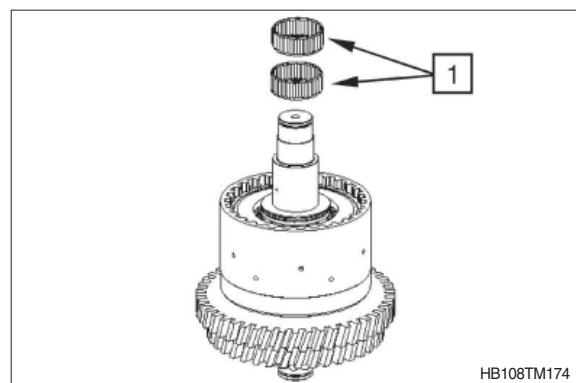

⑱ Mount inner disk carrier until contact is obtained.

⑲ Install inner disks by short ccw/cw rotations of the inner disk carrier (1).

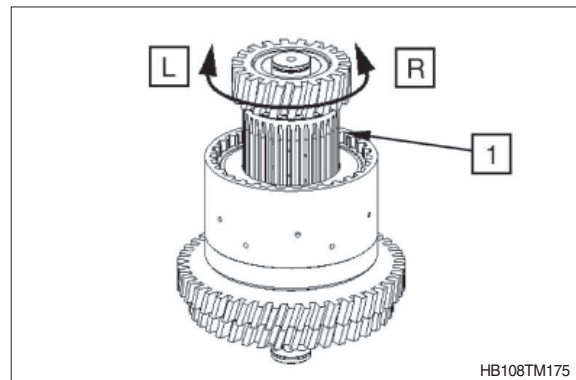

- ⑪ Install cup spring (1) according to the sketch.

Legend:

- 1 = Cup spring $122.7 \times 87 \times 2.55$ (convex side showing towards the piston)
 2 = Compression spring with spring cup and retaining ring
 3 = Piston with O-rings
 4 = Clutch assy

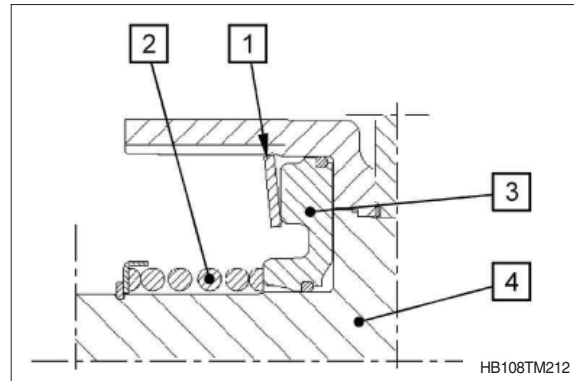

- ⑫ Install outer and inner disks alternately into the disk carrier (3) as shown in figure, starting with an outer disk and ending with an inner disk.

Legend:

- 1 = Outer disks (13 pcs)
 2 = Inner disks (13 pcs)
 3 = Clutch assy

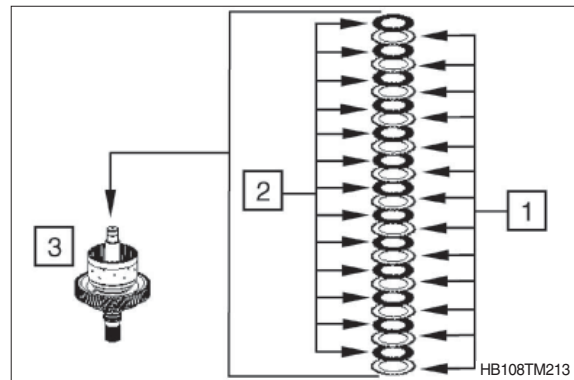

- ⑬ Mount end plate (1) with the flat side showing towards the disk package and fix it by means of snap ring (2) (e.g. thickness = 2.5 mm / recommended value).

※ Pay attention to the installation position of the end plate.

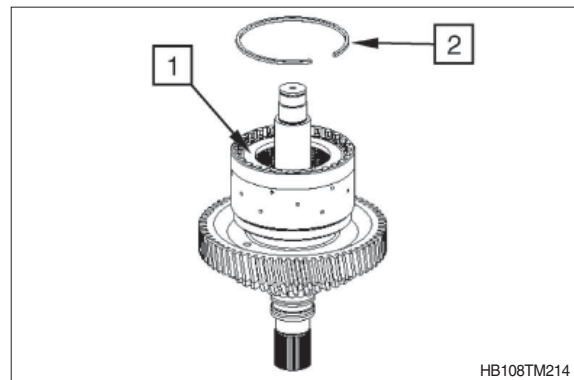

- ⑭ Equally press on end plate with F (approx. 1.8 kg to 2.0 kg) and set dial indicator to "zero".

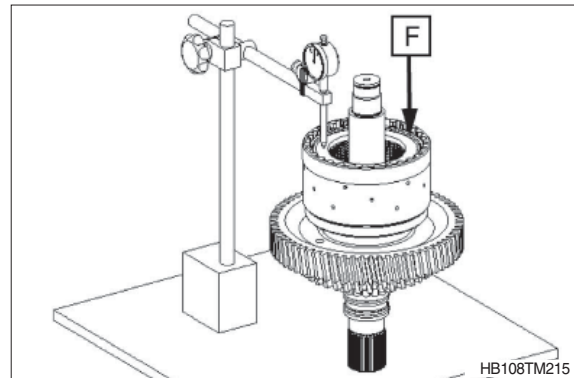

- ⑦ Mount compression spring (1) and spring cup (2).

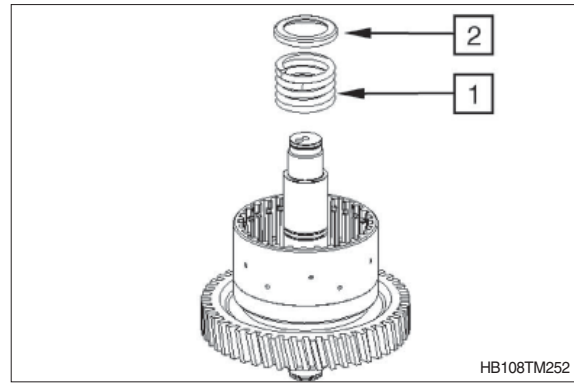

- ⑧ By means of the assembly aid, preload compression spring under a hand-operated press until the retaining ring 40×1.75 (1) can be snapped in.

(S) Assembly aid 5870 345 114

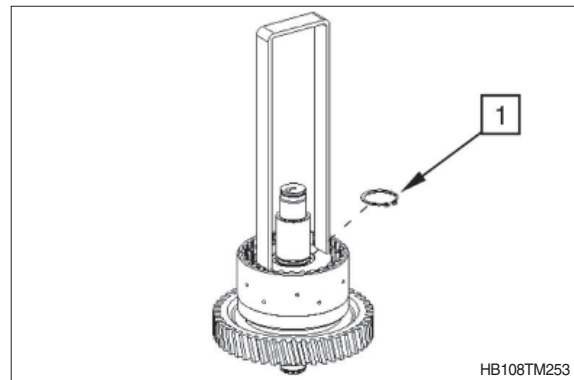

- ⑨ Mount plate assy with cup springs (1), with the open side showing towards the piston.

※ Installation position of plate see also the next figure ⑩.

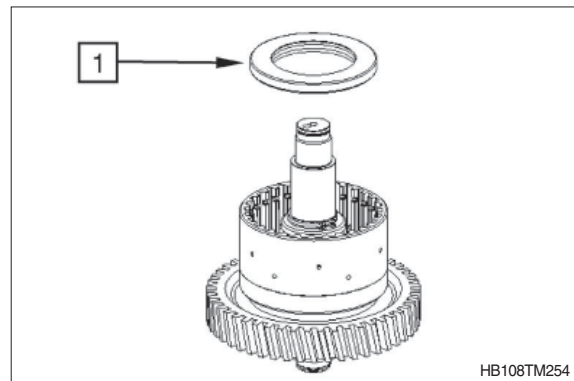

- ⑩ Fit plate (1) according to sketch (see arrow).

Legend:

- 1 = Plate assy with cup springs
- 2 = Compression spring with spring cup and retaining ring
- 3 = Piston with O-rings
- 4 = Input shaft assy

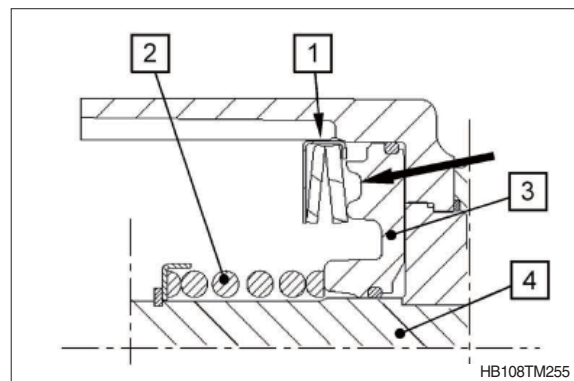

- ④ Fit stator hollow shaft (1).

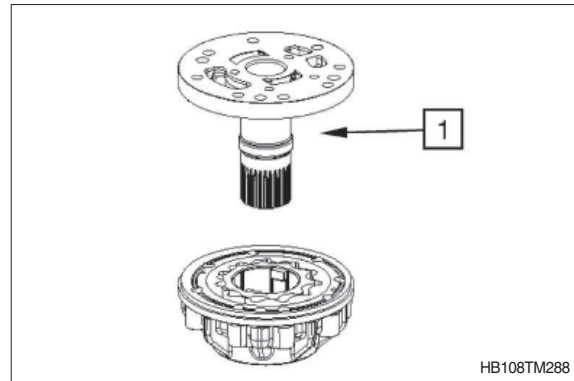

- ⑤ Fix stator hollow shaft radially with two cylindrical screws (1).

※ Do not tighten the cylindrical screws – just turn them in until contact is obtained and then turn them back by approx. 1/2 rotation.

Place O-ring (2) 135×3 into the annular groove and grease it.

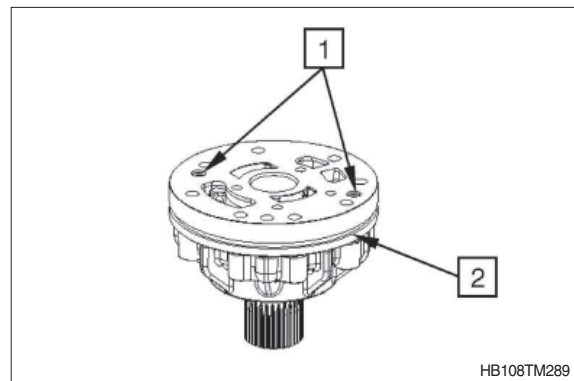

(2) Oil suction tube and oil filter tube

- ① Mount O-ring 30×3 (1) onto the suction tube (2) and grease it.

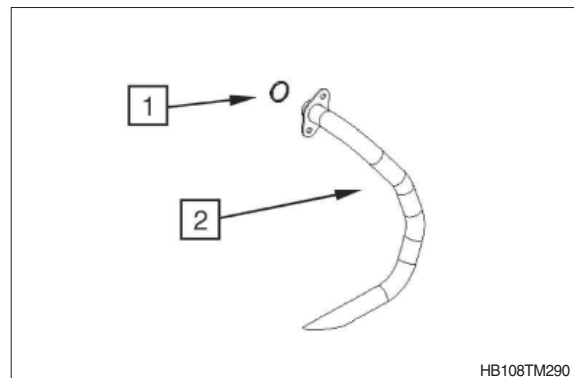

- ② Fix suction tube (1) with cylindrical screws M8×16 (2).

· Tightening torque M8/8.8×16 ;
2.35 kgf · m (17.0 lbf · ft)

※ When reusing the cylindrical screws these must be secured with loctite #243.

※ New cylindrical screws are already provided with adhesive (microcapsule). The microcapsule bursts when the screw is turned in, wets screw and nut thread and hardens.

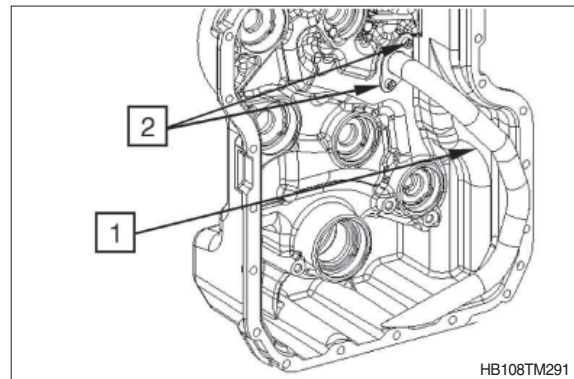

- ② Use the driver tool (S) to install screen sheet (2) onto the VA clutch shaft (3) until contact position (see figure TM321 of previous page).

(S) Driver tool 5870 048 310

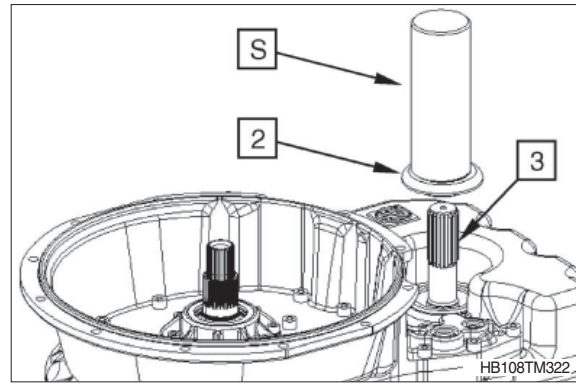

(3) Reassembly of screw plug at measuring point "63"

- ① Fit screw plug M14×1.5 (1) with new O-ring 11×2 (2).

· Tightening torque ;
2.55 kgf · m (18.4 lbf · ft)

※ Refer to page 3-23 for measuring point 63.

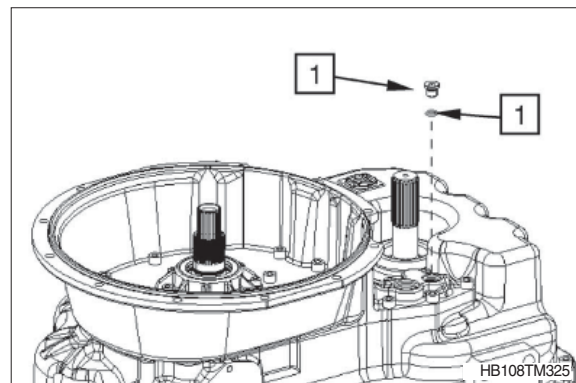

4) AXLE BEAM GROUP DISASSEMBLY

※ Some of the following pictures may not show exactly your axle, but the process is the same.

- (1) Remove the upper bushings and the ball bearing cups from king pin seats with a suitable extractor only if replacement is required.

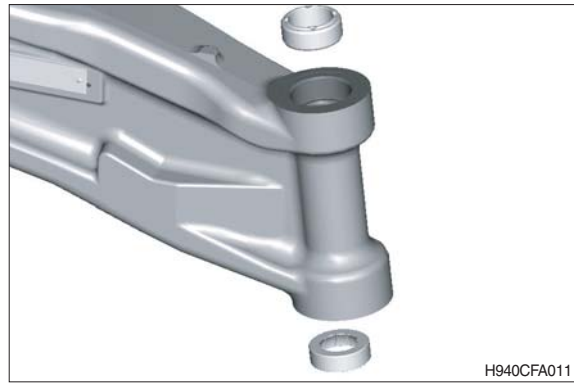

- (2) Remove the rear and front seals from the pivot using a suitable tool.

※ This is a destructive operation for the seal rings.

Remove the rear and front bushings from the axle beam pivot only if replacement is necessary.

※ This is a destructive operation for the bushings. Pay attention not to damage the bushing seats.

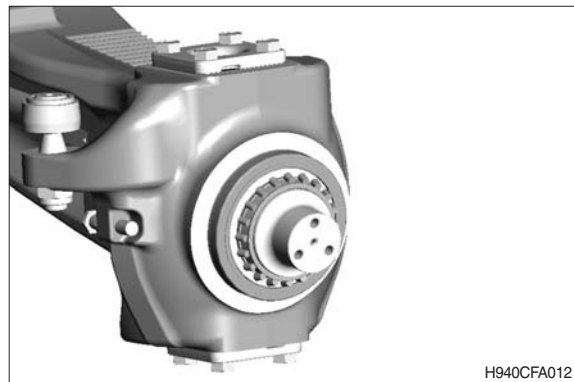

(5) Disengage the retaining ring.



(6) Pull off the planetary gear with the cylindrical roller bearing.



(7) Loosen the locking screws.

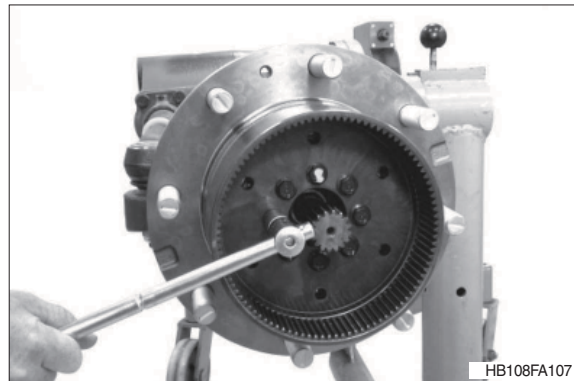

(8) Pull the ring gear with a three-armed puller from the knuckle housing/from the bushes.

(S) Pressure piece 5870 100 080

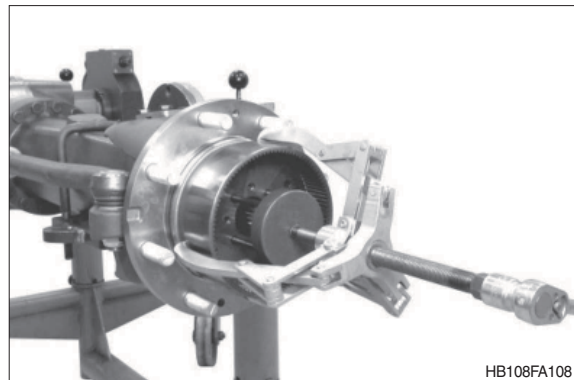

(5) Loosen the hexagon nut and remove the shim lying behind.

(S) Clamping fork 5870 240 025

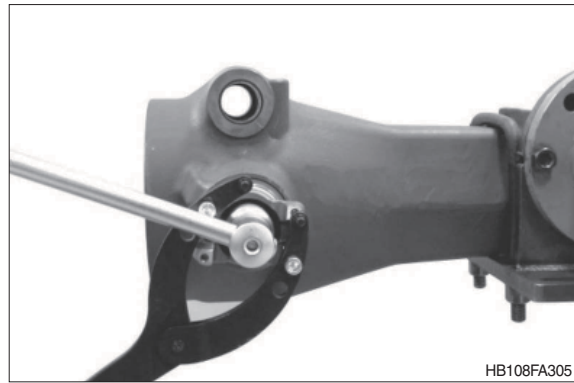

(6) Pull the yoke from the input pinion.

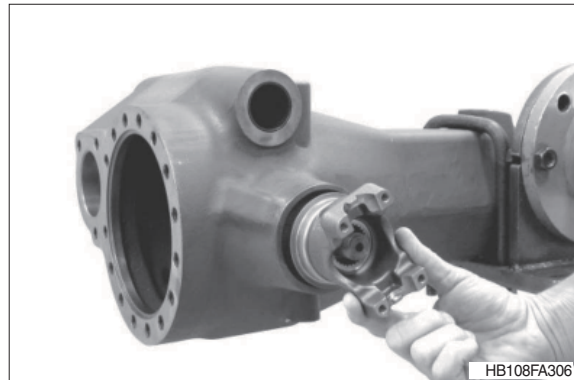

(7) Press the screen sheet with the cut-off device (S) from the yoke.

(S) Cut-off device 5870 300 024

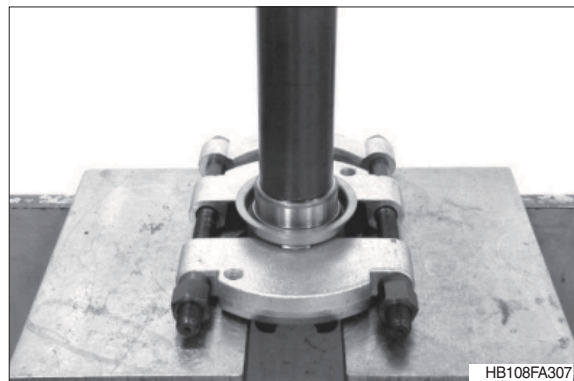

(8) Force the input pinion out of the axle housing.

※ If the pinion bearing should not be replaced, special care must be taken that the outer bearing inner ring is always in contact position with the bearing outer ring when forcing the input pinion out.

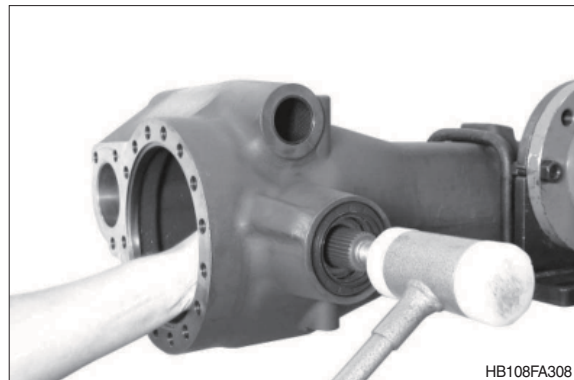

- ⑤ Heat the roller bearing and mount until contact is obtained.
- ※ Adjust the bearing after cooling down.

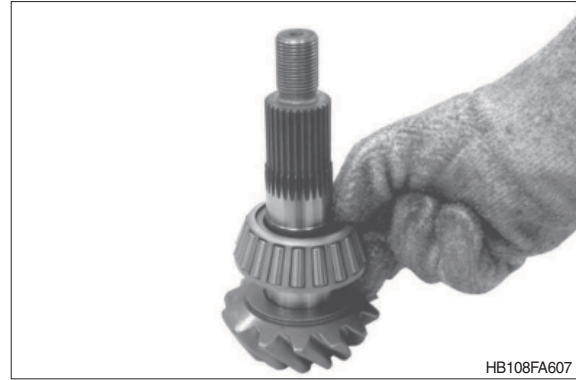

Setting of the rolling torque of the input pinion bearing 0.1~0.31 kgf · m (without shaft seal ring)

- ① Mount bush (1) and spacer (2), e.g. $s = 6.40$ mm.
- ※ Experience has shown that the required rolling torque is reached when reusing the shims being removed during disassembly (e.g. $s = 6.40$ mm). A later check of the rolling torque, however, is absolutely necessary.

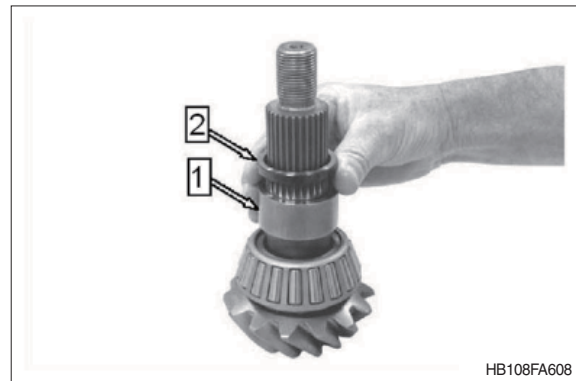

- ② Insert the preassembled input pinion into the axle housing and mount the heated roller bearing until contact is obtained.

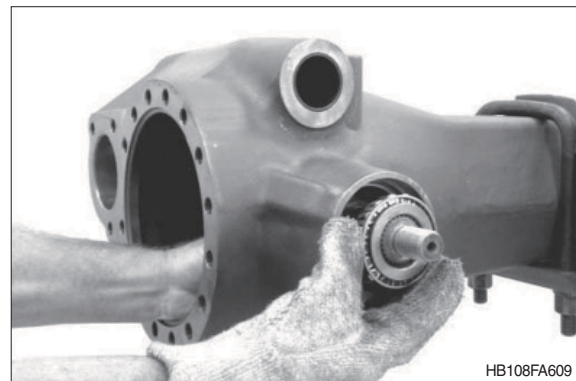

- ③ Press the screen sheet (see arrow) onto the yoke until contact is obtained.
- ※ The shaft seal ring is only mounted after acceptance of the contact pattern (see page 3-155).

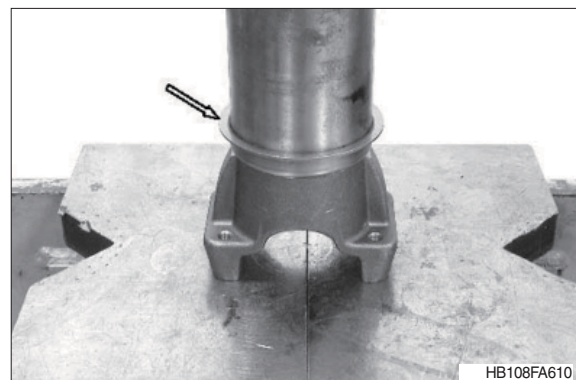

Mount the double U-joint shaft

① Insert the double U-joint shaft into the knuckle housing.

※ Right before the assembly wet the cassette type seal ring with spirit.

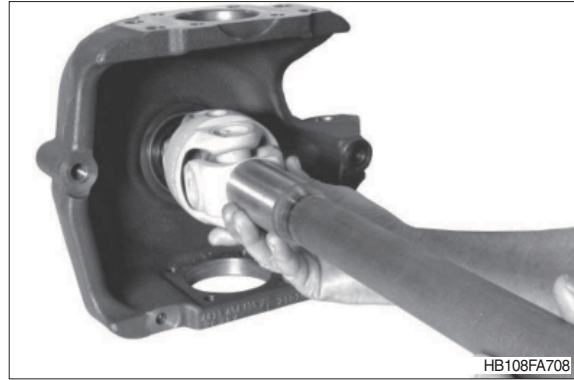

② Pull the double U-joint shaft into the knuckle housing until contact is obtained.

(S) Internal extractor 5870 300 014

(S) Counter support 5870 300 003

※ Place the internal extractor (S) into the groove of the double U-joint shaft.

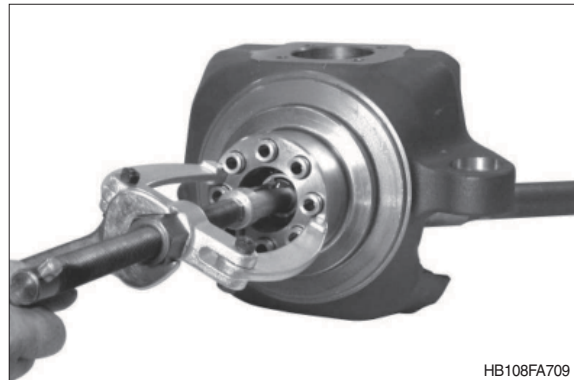

③ Fix the double U-joint shaft with a retaining ring.



④ Insert the retaining ring into the groove of the double U-joint shaft.



(3) Adjustment and check of track

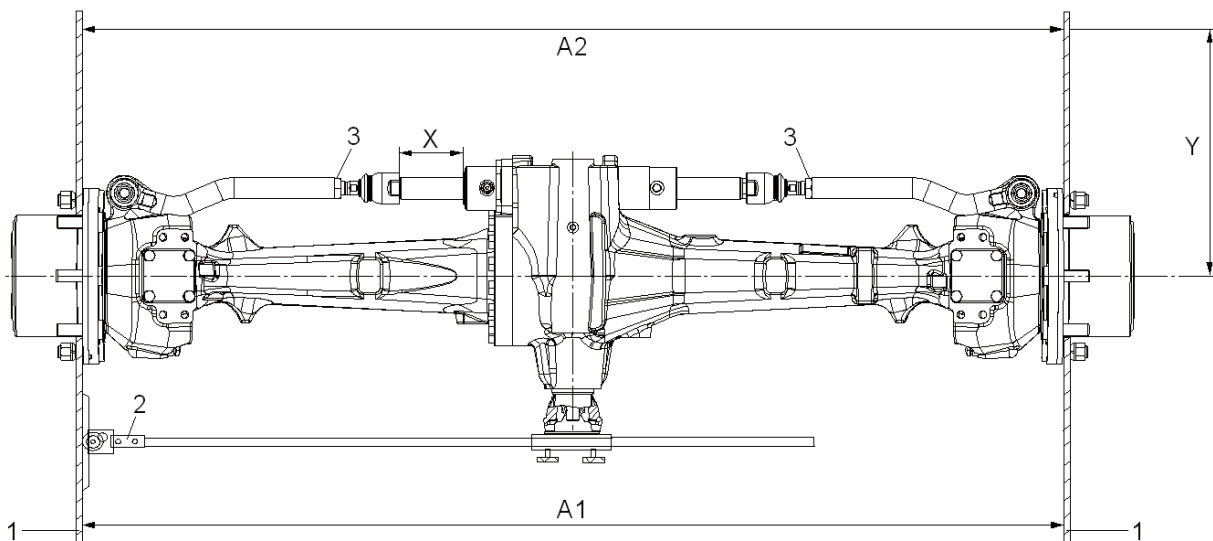

HB108FA817

Basic track setting

Bring the piston rod into central position.

Setting of dimension $X = 121.75$ mm (measured between front face/steering cylinder and front face/axial joint).

- ※ The axial position of the piston rod may no more be changed during track setting.
Mount the straightedges (1) in horizontal and central axis position.
Fix the measuring device (2) to the yoke.
Loosen the hexagon nut (3) and set the length of the tie rod (axial joint), until 0° (= track setting of zero mm) can be read on the measuring device (2).
- ※ For a toe-in and toe-out setting, which might be required, stick to the vehicle manufacturer's specification.
- ※ Carry out setting on both output sides.

Comment on sketch:

1 = (S) Straightedges 5870 200 029

2 = (S) Measuring device 5870 200 033

3 = Hexagon nut

X = Setting dimension 121.75 mm

Check track setting (0°) :

Determine dimension A1.

Turn both outputs by 180° – Dimension A2 must be identical with dimension A1.

Dimension Y = distance between wheel center and rim flange.

Then fix both tie rods (axial joint) with hexagon nut (3).

- Tightening torque : $30.6 \text{ kgf} \cdot \text{m}$ ($221 \text{ lbf} \cdot \text{ft}$)

(4) Remove bearing housing.

※ Pay attention that releasing O-rings do not drop.

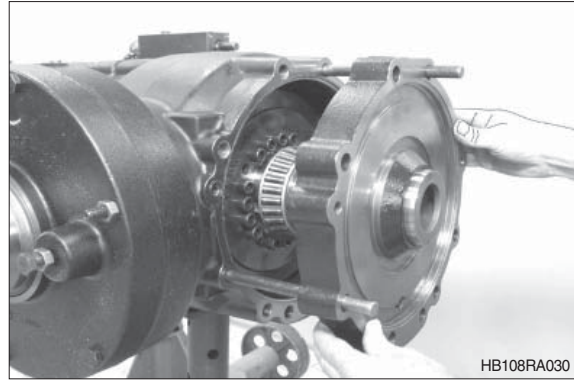

(5) Press off piston by means of compressed air and remove O-ring (arrow).

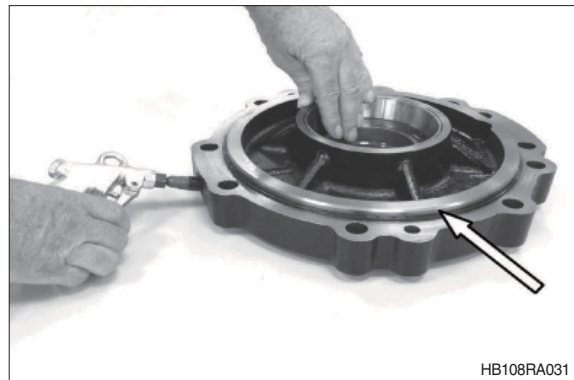

(6) Remove bearing outer ring and shim (differential bearing preload).



(7) Remove sealing elements (arrows) from bearing housing.



- (8) Take disc package out of brake housing cover.



- (9) Remove sealing elements-see arrows- from the grooves of the brake housing cover.



- (10) Pull off both bolts (with O-ring).
Remove O-ring (arrow).

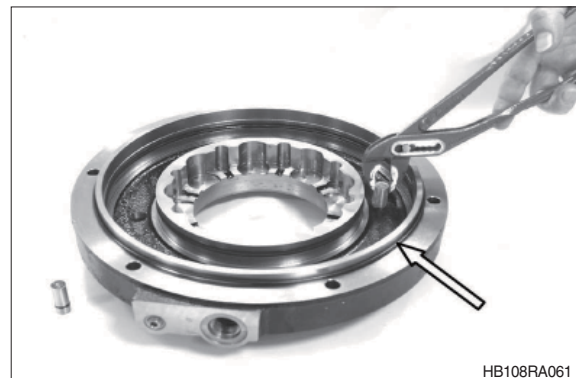

- (11) If required, disassemble brake housing (figure RA062+063) : For this purpose, the cpl. differential must be dismantled first-in this connection see parts of section **3) Disassembly differential of page 3-176.**

Press-off input pinion using a two-armed puller-pay attention that releasing bearing inner ring does not drop.

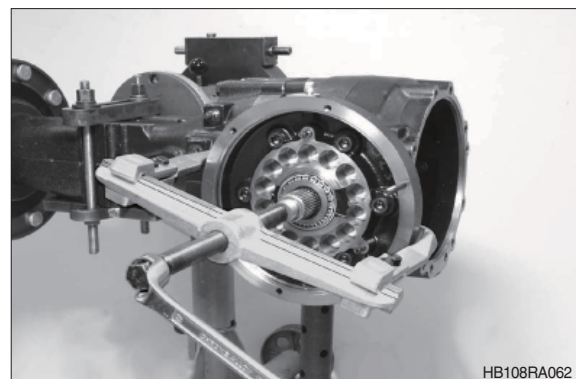

(7) Position pre-assembled differential carrier half II on differential carrier half I.

※ Ensure radial installation of both differential carrier halves – punch-marked no. (see arrow) corresponds to radial position marking.



(8) Position crown wheel on slotted pins and press onto differential carrier until contact is obtained.

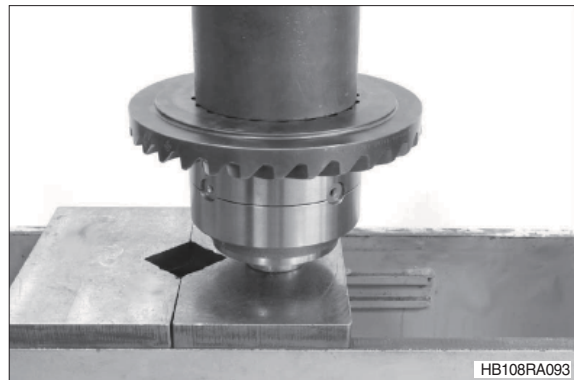

(9) Fix differential by means of a press and connect differential carrier halves with cylinder screws.

· Tightening torque (M 12/12.9) :
13.8 kgf · m (99.6 lbf · ft)

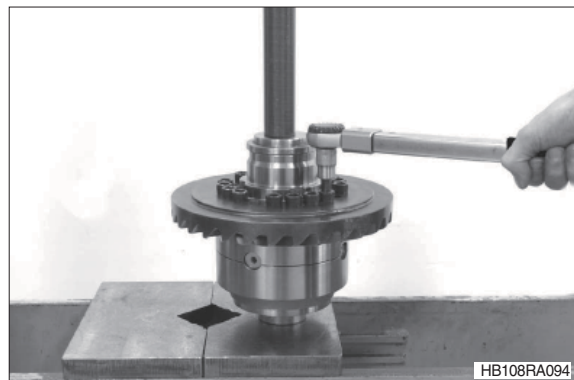

(10) Install both bearing inner rings.

※ Use suitable support (arrow) – differential must not be supported on bearing cage.



CLICK HERE TO **DOWNLOAD** THE COMPLETE MANUAL

- Thank you very much for reading the preview of the manual.
- You can download the complete manual from: www.heydownloads.com by clicking the link below



- Please note: If there is no response to CLICKING the link, please download this PDF first and then click on it.

CLICK HERE TO **DOWNLOAD** THE COMPLETE MANUAL

- (9) Press down cup spring preload using a press, and snap in retaining ring (8).

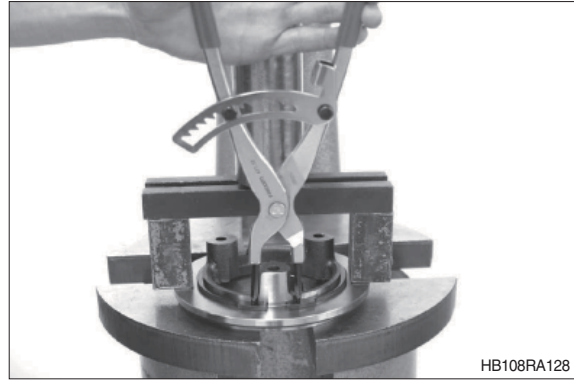

- (10) Insert preassembled ring and fix with cylinder screws.

※ Install cylinder screws with locking compound (loctite #262).

- Tightening torque (M8/8.8) :
2.35 kgf · m (17 lbf · ft)

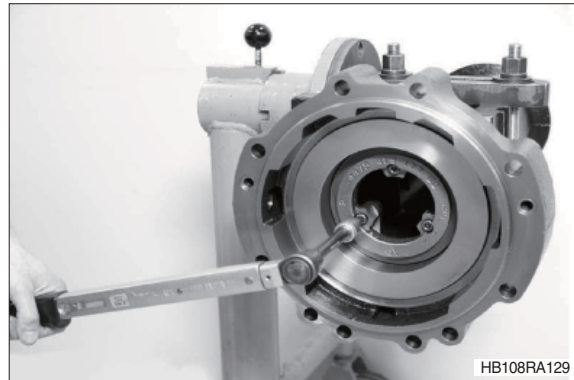

- (11) 1 = Outer discs
2 = Inner discs (lined discs)

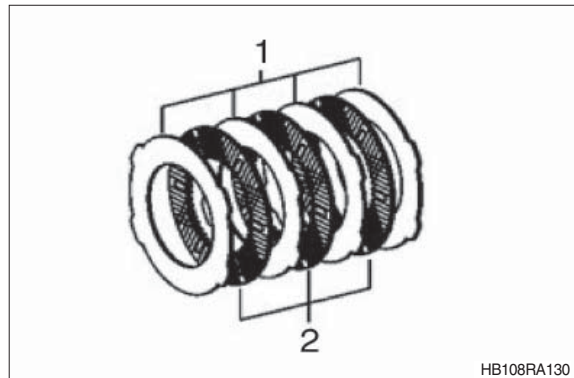

- (12) Locate disc package – **taking the disc arrangement into consideration (see sketch above).**

※ Fix outside disc with grease – assembly aid.

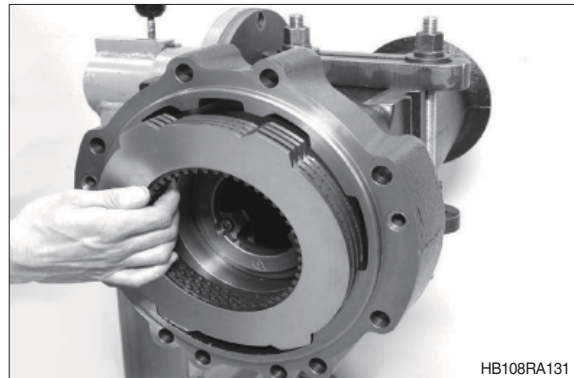

- (3) Insert both bolts (arrows) with O-ring into the brake housing cover – **observing the installation position, see sketch RA161.**

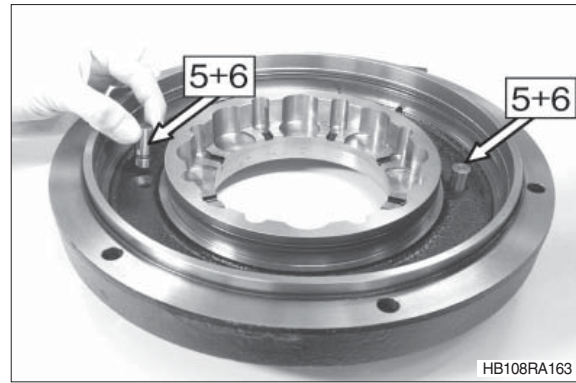

- (4) 1 = Outer discs (steel discs)
2 = Inner discs (lined discs)

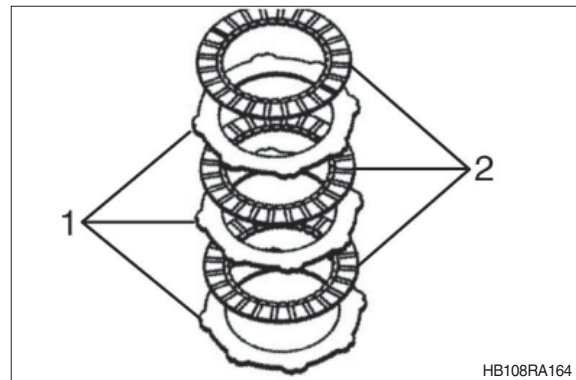

- (5) Insert disc package into the brake housing cover – **observing the disc arrangement (see sketch above) starting with an outer disc.**



- (6) Oil sealing surface of piston and of brake housing cover and press piston into the brake housing cover to contact position.

- ※ Press in piston without tilting – risk of damage to grooved rings and piston.

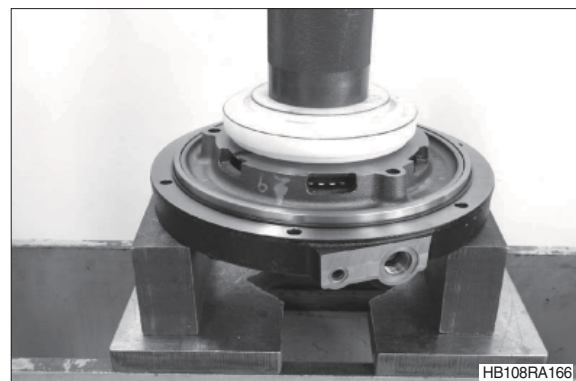

SECTION 4 BRAKE SYSTEM

GROUP 1 STRUCTURE AND FUNCTION

1. OUTLINE

1) MASTER CYLINDER TYPE

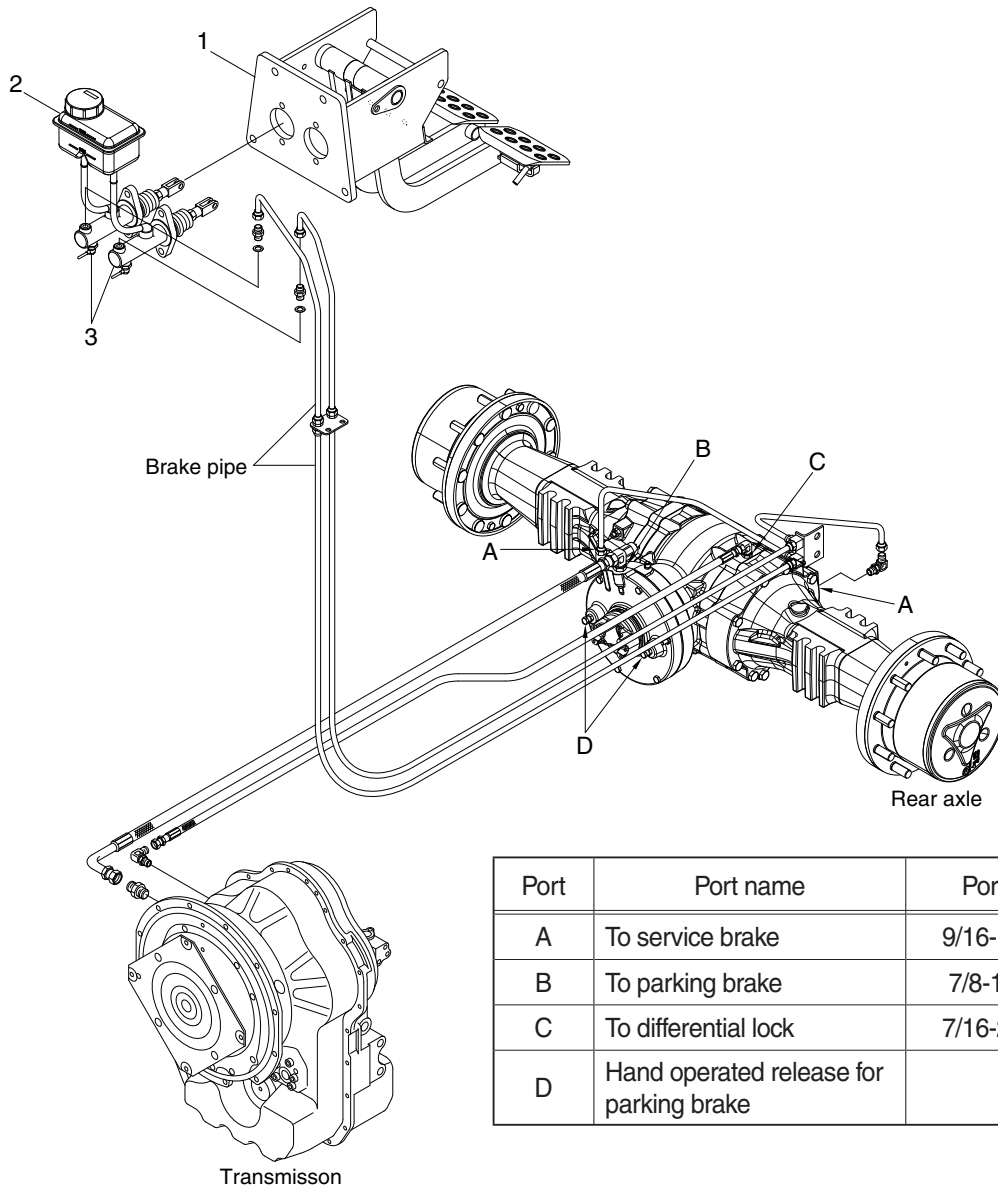

- 1 Brake pedal & bracket assembly
- 3 Brake master cylinder

- 2 Reservoir tank assembly

OPERATION

Compensating master cylinders overcome the problem of unequal wear between the right and left brake. The units incorporate both master cylinder and compensating valve.

Each brake has its own master cylinder, brake pedals, servo units and associated pipework. Both master cylinders have one common reservoir.

(3) One pedal applied

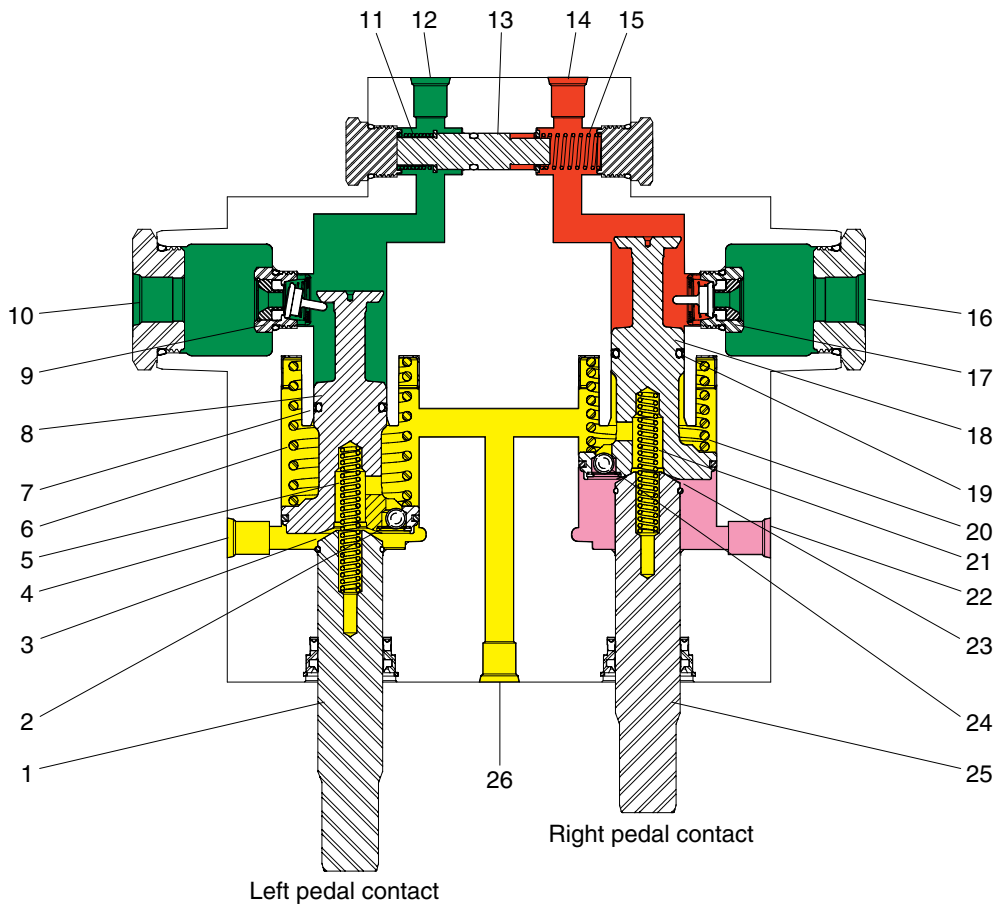

- Modulated pressure
- Unrestricted flow
- Brake system pressure
- Atmospheric pressure

H940CB4SM04

When only one pedal is applied, the opposite side brake remains at reservoir pressure. This system works the same as described in page 4-10 except piston (13) moves full stroke then stops and brake pressure is developed by the same means as described in page 4-10. The effort required on one pedal is one half that of the effort when applying both pedals to obtain the same brake pressure.

4. STEERING UNIT LEAKAGE TEST

- **SPECIFICATION**

Oil temperature $45 \pm 5^{\circ}\text{C}$ ($113 \pm 9^{\circ}\text{F}$)

Engine speed High idle

Maximum leakage 10 l /min

- **GAUGE AND TOOL**

Temperature reader

Measuring container (approx. 20 l)

Stop watch

- 1) Install temperature reader.
(see temperature reader installation procedure in this group).
- 2) Heat hydraulic oil to specifications.
(see hydraulic oil warm up procedure at page 6-87).
- 3) Disconnect return hose from fitting.
Install cap fitting.
- 4) Run engine at specifications. Rotate steering wheel against locking bar using approximately 1.2 kgf · m of force.
Measure oil flow from return hose for 1 minute.
- 5) Leakage is greater than specifications, repair or replace steering unit.

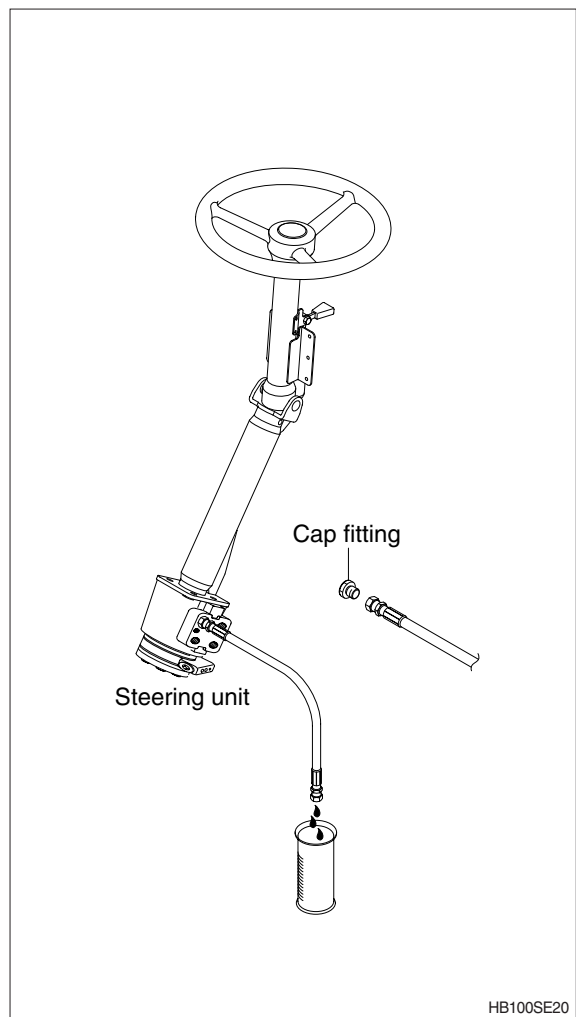



HB100SE20

SECTION 5 STEERING SYSTEM

Group 1	Structure and Function	5-1
Group 2	Operational Checks and Troubleshooting	5-9
Group 3	Tests and Adjustments	5-16
Group 4	Disassembly and Assembly	5-23

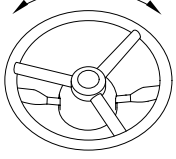
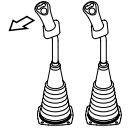
※ Hydraulic oil must be at operating temperature for these checks (refer to page 6-87).

Item	Description	Service action
<p>Steering unit check</p>	<p>Run engine at low idle.</p> <p>Turn steering wheel until frames are at maximum right and then left positions.</p> <p>LOOK : Frames must move smoothly in both directions.</p> <p>When steering wheel is stopped, frames must stop.</p> <p>FEEL : Excessive effort must not be required to turn steering wheel.</p> <p>NOTE : It is normal for steering to drift from stops when steering wheel is released.</p>	<p>OK Check completed.</p> <p>NOT OK Go to next check.</p>
<p>Steering system leakage check Heat hydraulic oil to operating temperature. Run engine at high idle.</p>	<div style="display: flex; align-items: center;"> <div style="margin-right: 20px;"> <p>Left</p> <p>Right</p>  </div> <div> <p>Turn steering wheel rapidly until frames are against stop.</p> <p>Hold approximately 2kg on steering wheel.</p> <p>Count steering wheel revolutions for 1 minute.</p> <p>Repeat test in opposite direction.</p> <p>LOOK : Steering wheel should rotate less than 7rpm.</p> <p>NOTE : Use good judgment; Excessive steering wheel rpm does not mean steering will be affected.</p> </div> </div>	<p>OK Check completed.</p> <p>NOT OK Do steering system leakage test in group 3 to isolate the leakage.</p>
<p>Priority valve (in main pump) low pressure check</p>	<p>Park machine on a hard surface.</p> <p>Hold brake pedal down.</p> <p>Run engine at high idle.</p> <p>Steer machine to the right and left as far as possible.</p> <p>LOOK : Machine must turn at least half way to the right and left stops.</p>	<p>OK Check completed.</p> <p>NOT OK Do priority valve pressure test in group 3.</p>
<p>Priority valve (in main pump valve) high pressure check Run engine at high idle.</p>	<div style="display: flex; flex-direction: column; align-items: center;"> <div style="margin-bottom: 20px;"> <p>Mechanical</p>  </div> <div> <p>Pilot</p>  </div> </div> <p>Steer to steering stop and release steering wheel.</p> <p>Roll bucket back and hold over relief and observe engine rpm.</p> <p>Turn steering wheel to steering stop and hold, observe engine rpm.</p> <p>LOOK : Steering stall engine rpm must be higher than hydraulic stall rpm.</p>	<p>OK Check completed.</p> <p>NOT OK Priority pressure is set too high. Do priority valve pressure test in group 3.</p>

4) ASSEMBLY

(1) Preparation

- ※ Make the service job more easier by keeping the following:
 - Having read and understood this manual thoroughly.
 - Working in a clean, well-lighted place.
 - Setting the proper tools and helping material neatly.
 - Having an adequate amount of clean petroleum-based solvent.
- ▲ **Be extremely careful when using any solvent. Since solvent are naturally flammable, even a small amount of solvent cause explosion or fire resulting in injury or death.**
- ※ **Thoroughly check all the machined surfaces.**

All mating surfaces should be thoroughly checked now. Replace any parts that have scratches that could cause leakage. Do not grind these machined surfaces because it is dangerous to do so and the surfaces are machined with high precision technology.
- ※ **Since the most moving parts are manufactured to meet high precision requirement, the sharp edges on them could act as knives. Handle carefully with those parts to prevent from cutting your fingers.**
- ※ **Clean and lubricate the parts**

Clean all metal parts in new petroleum-based solvent. Blow them dry with compressed air. Do not use cloth or paper towel to wipe them dry because lint or other matter can get into the components and eventually into the hydraulic system.
- ※ **Keep parts separately. Replace all seals and lubricate them with clean petroleum jelly.**

Lubricate machined surfaces and bearings with clean hydraulic fluid. This helps them to be installed easily and provide initial lubrication. Do not use excessive lubricant on seals for gerotor section.
- ▲ **Be sure to comply with other requirements for the compressed air.**

- (20) Carefully remove bearing and races, anti-cavitation valves and manual steering check valve (roll pin and ball) from bolt holes by tipping housing gerotor side down (see figure).
- (21) Do not remove any valves other than manual steering check valve assembly and anti-cavitation valve assembly. All other valves are factory preset and are non-serviceable.
- (22) Carefully remove seal with a thin-blade screw driver.
Do not scratch seal groove with screw driver.
- (23) Use thin bladed screw driver to pry dust seal from housing. Do not damage housing.

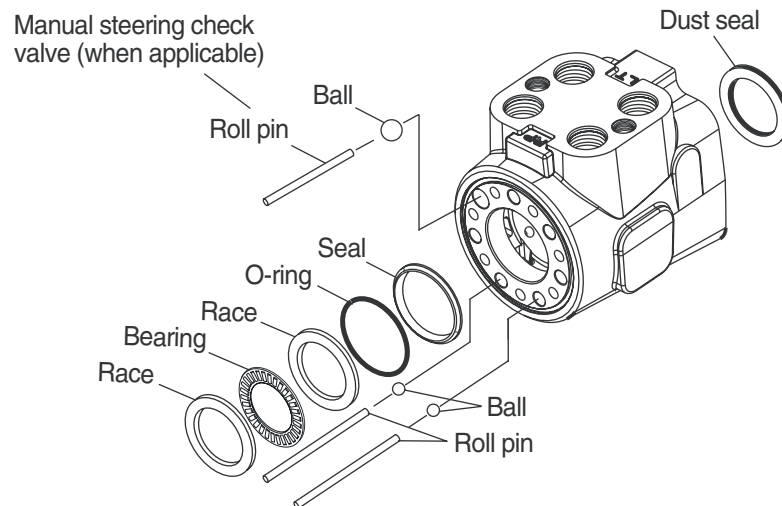

HB100SE35

- (24) Push pin from spool and sleeve assembly.
- (25) Remove drive.
- (26) Push spool partially from control end of sleeve, then carefully remove centering springs and retaining ring from spool by hand (see figure).

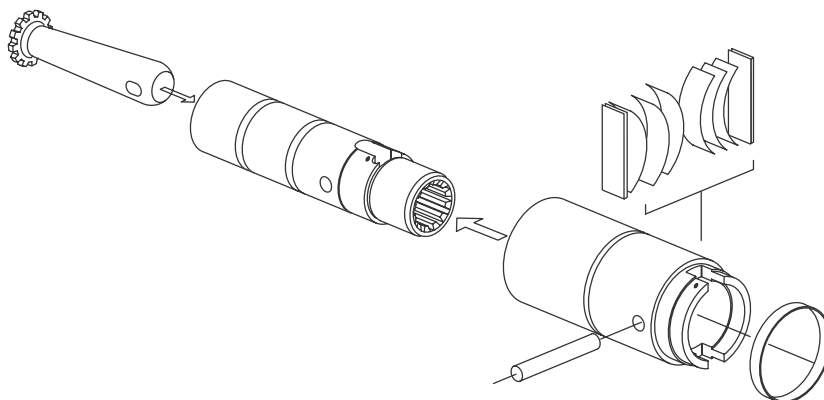

HB100SE36

SECTION 6 WORK EQUIPMENT

Group 1 Structure and Function	6-1
Group 2 Operational Checks and Troubleshooting	6-71
Group 3 Tests and Adjustments	6-84
Group 4 Disassembly and Assembly	6-96

6) LOW SPEED CONTROL FUNCTION

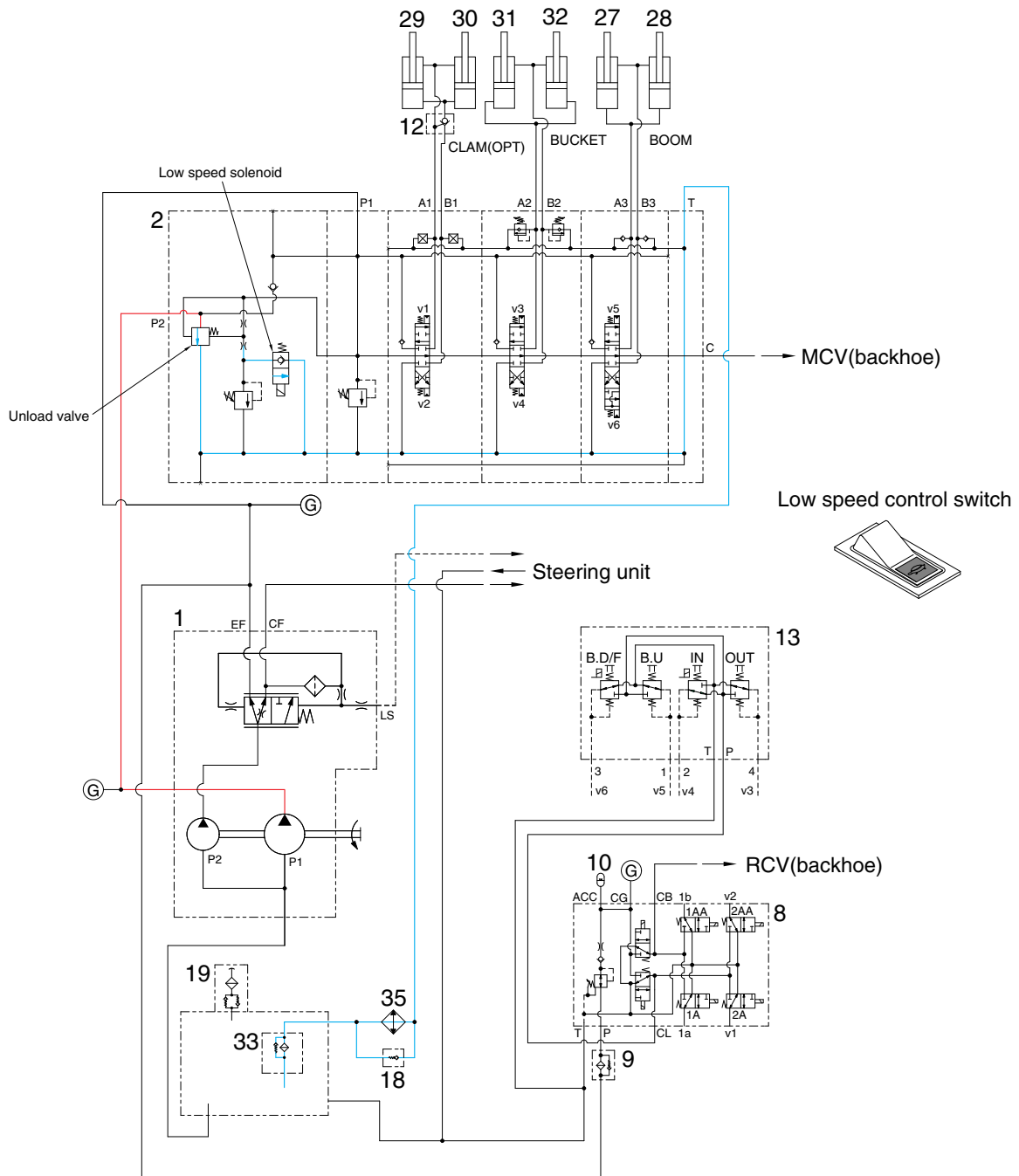

H940C6WE06-1

- If the low speed control switch is pushed ON, the low speed solenoid is energized . Then unload valve is opened and the oil from P1 pump return to the tank. This makes loader speed slow.

8) STABILIZER UP OPERATION

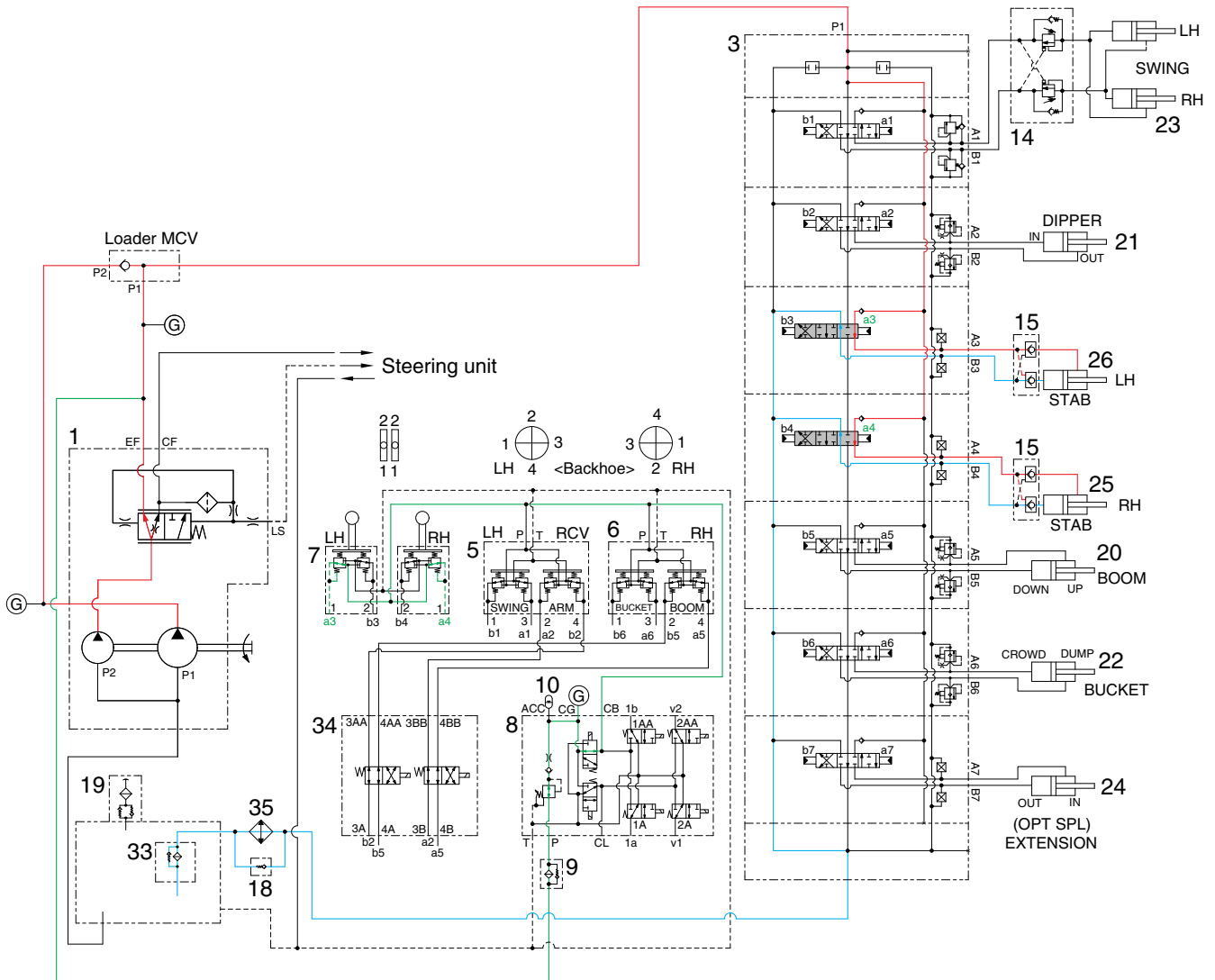

H940C6WE16

When the stabilizer control levers (7) are pulled back, the spools in the main control valve (3) are moved to the stabilizer up position by the pilot oil pressure from the remote control valve (7).

The oil from the pump (P1, P2) flows into the main control valve and then goes to the small chambers of stabilizer cylinders.

At the same time, the oil from the large chambers of stabilizer cylinders return to the hydraulic oil tank through the spools in the main control valve. When this happens, the stabilizers go up.

Each stabilizer (LH or RH) is operated separately.

(2) Pilot control

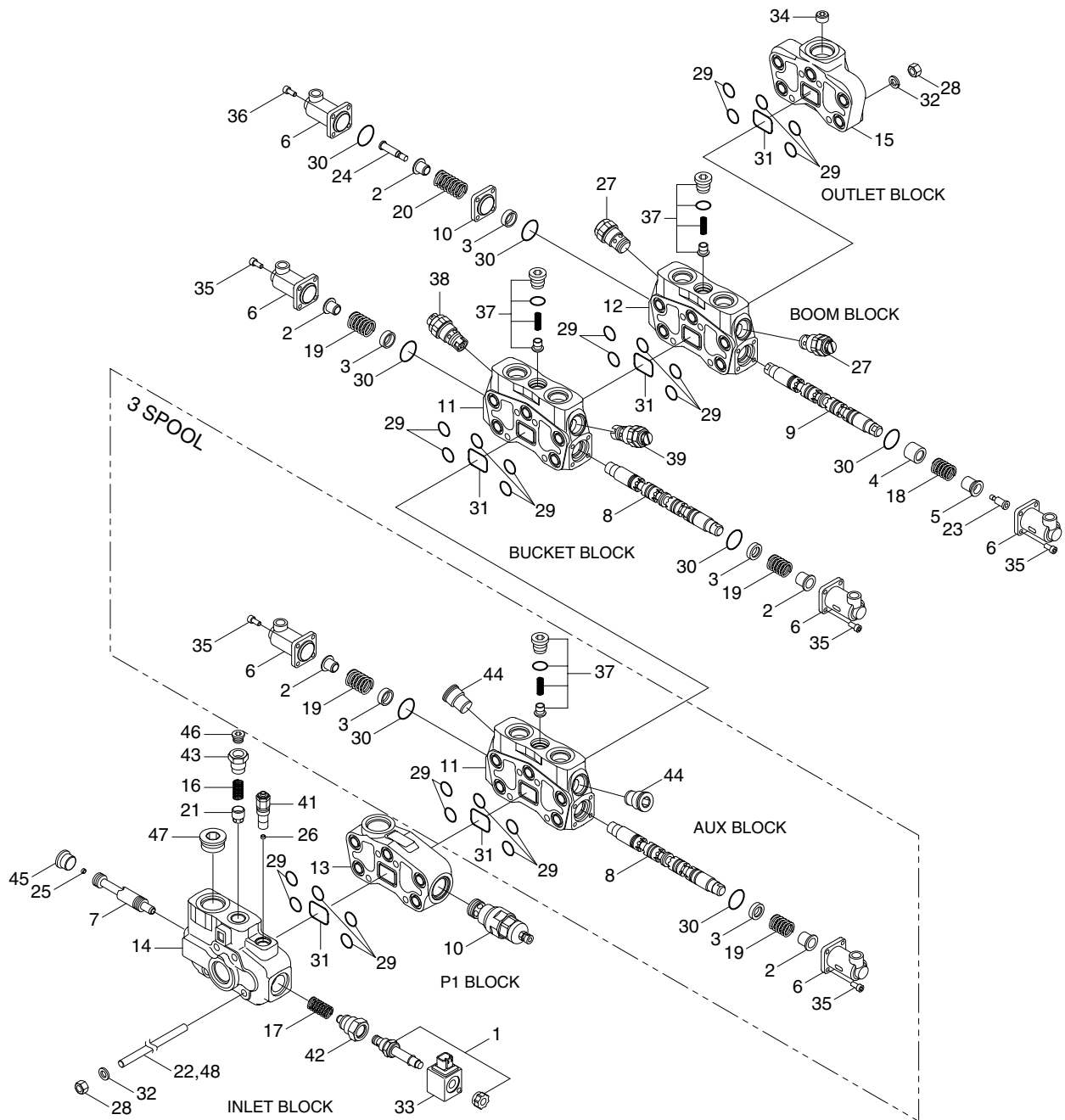

H940C6WE37

1	Solenoid valve	13	Element	25	Screw	37	Check valve
2	Spring cap	14	Inlet cover	26	Screw	38	Valve
3	Bushing	15	Outlet cover	27	Cartridge	39	Valve
4	Bushing	16	Spring	28	Nut	40	Valve
5	Bushing	17	Spring	29	O-ring	41	Cartridge
6	Cap	18	Spring	30	O-ring	42	Inlet cover joint
7	Spool	19	Spring	31	O-ring	43	Adapter
8	Spool	20	Spring control kit	32	Spring washer	44	Plug
9	Spool	21	Poppet	33	Coil	45	Plug
10	Spacer	22	Tie rod	34	Conical plug	46	Plug
11	Element	23	Screw	35	Bolt	47	Plug
12	Element	24	Screw	36	Screw		

Pilot control (2/3)

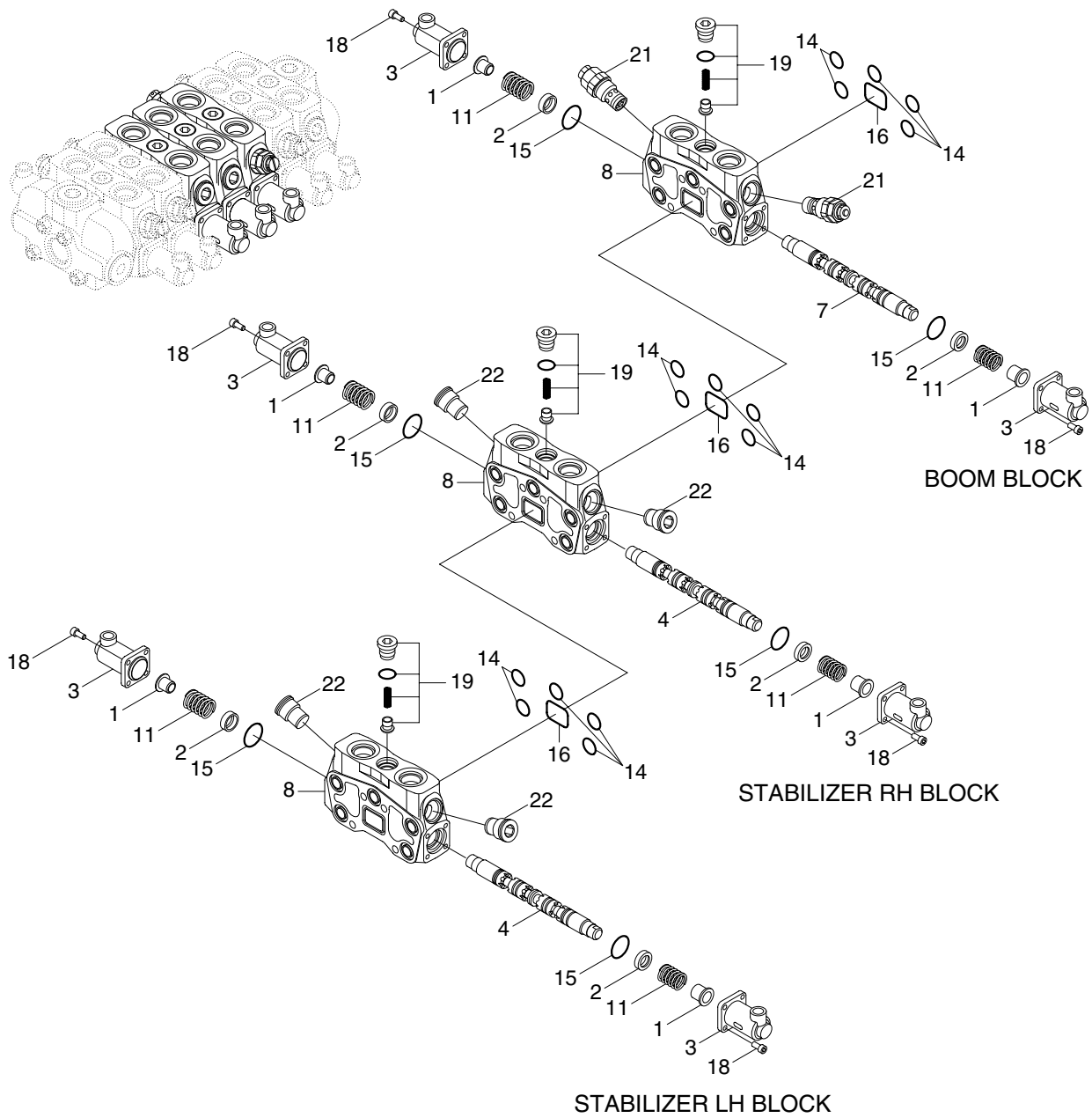

- 1 Spring cap
- 2 Bushing
- 3 End cap
- 4 Spool
- 7 Spool

- 8 Block
- 11 Spring
- 14 O-ring
- 15 O-ring
- 16 O-ring

- 18 Bolt
- 19 Check valve
- 21 Relief valve
- 22 Plug

H940C6WE41

(3) Bucket dump position (when moving the bucket to your right)

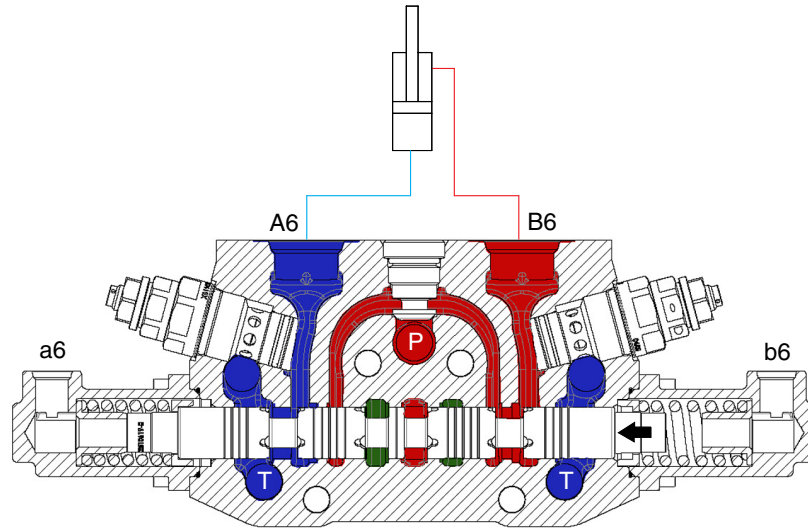

When the bucket spool moves to the left, the pressure oil supplied from the pump flow through cylinder port (B6) into bucket cylinder.

The return oil from cylinder port (A6) flows into the tank via the low pressure passage.

7) EXTENDED DIPPER SECTION OPERATION

(1) Spool in neutral

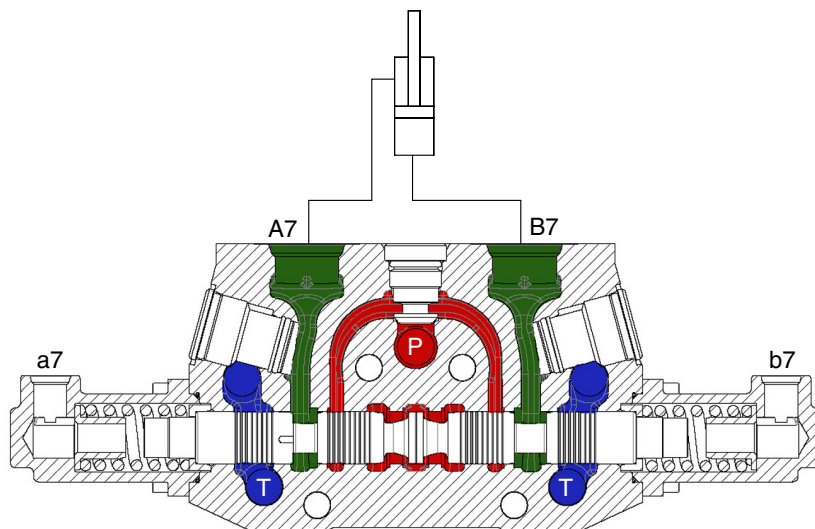

2) BUCKET CYLINDER

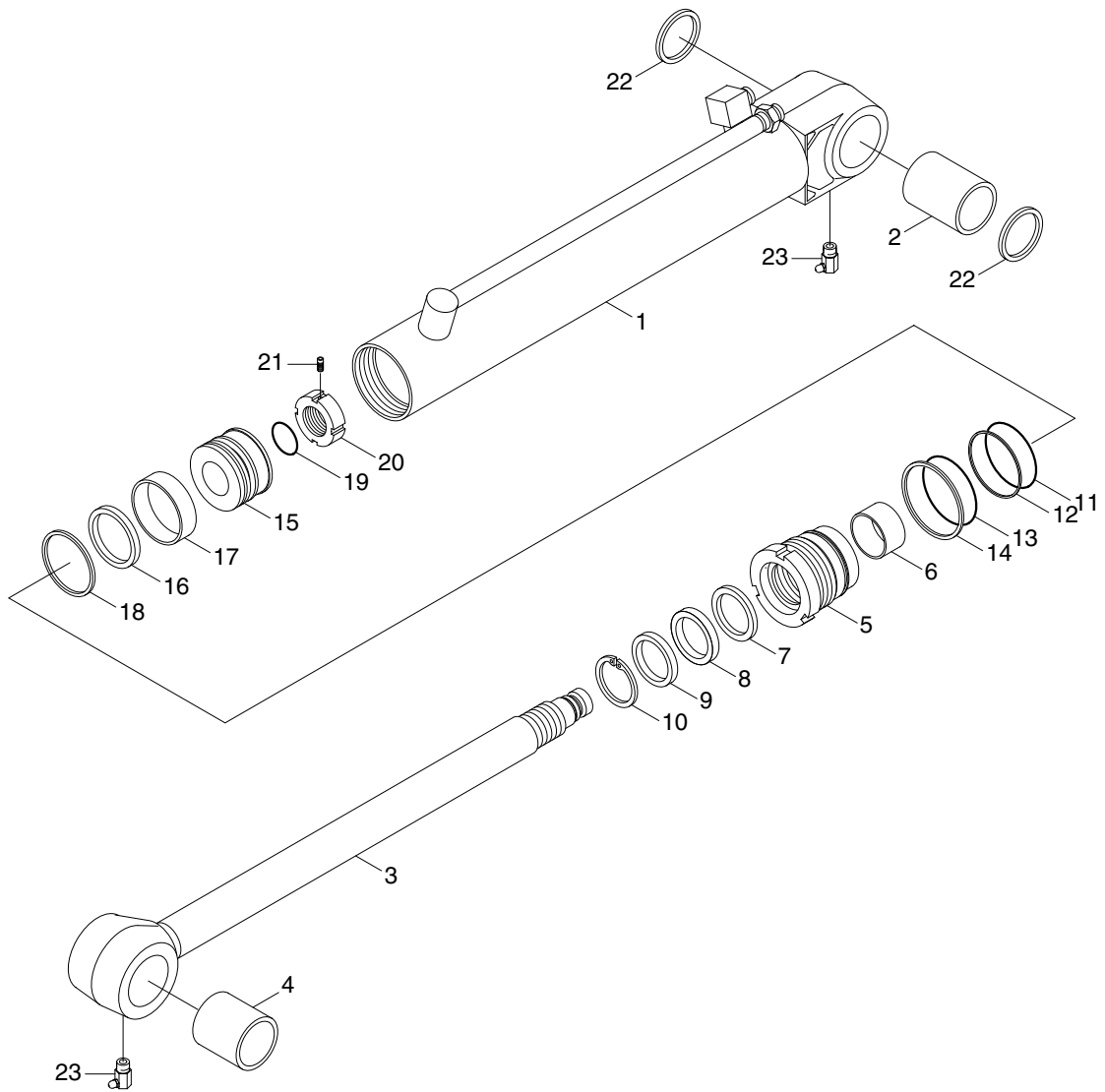

H940C6WE136

- | | | | | | |
|---|---------------|----|----------------|----|---------------|
| 1 | Tube assembly | 9 | Dust wiper | 17 | Wear ring |
| 2 | Pin bushing | 10 | Retaining ring | 18 | Dust ring |
| 3 | Rod assembly | 11 | O-ring | 19 | O-ring |
| 4 | Pin bushing | 12 | Back up ring | 20 | Piston nut |
| 5 | Rod cover | 13 | O-ring | 21 | Set screw |
| 6 | Rod bushing | 14 | Washer | 22 | Pin wiper |
| 7 | Buffer seal | 15 | Piston | 23 | Grease nipple |
| 8 | U-packing | 16 | Piston seal | | |

12. ACCUMULATOR

The accumulator is installed at the pilot oil supply unit. When the boom is left the raised position, and the control levers are operated with the engine stopped the pressure of the compressed nitrogen gas inside the accumulator sends pilot pressure to the control valve to actuate it and allow the boom and bucket to come down under their own weight.

Type of gas	Nitrogen gas (N ₂)
Volume of gas	0.35 l (0.1 U.S.gal)
Charging pressure of gas	15 kg/cm ² (213 psi)
Max actuating pressure	170 kg/cm ² (2420 psi)

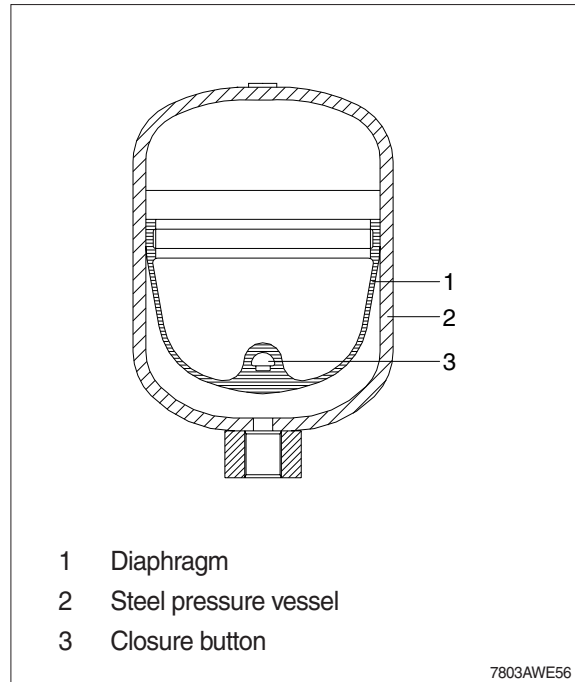

13. RIDE CONTROL VALVE

Item	Description
Diameter	125 mm
Mounting height	403 mm
Capacity	1.5 l
Max working pressure	357 kgf/cm ²
Precharge pressure (at 20°C)	31 ± 1 kgf/cm ²
Precharge gas	Nitrogen
Portsize (A, B, T)	3/4-16UNF

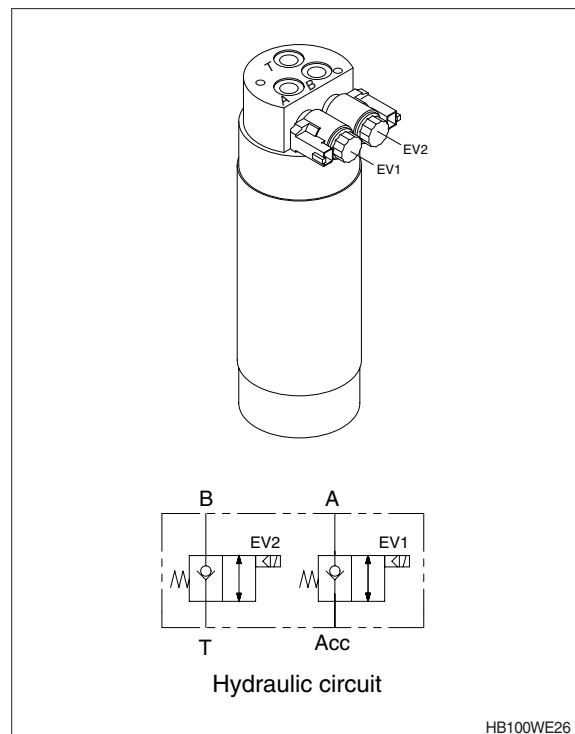

Problem	Cause	Remedy
No steering or hydraulic function	Low oil level. Failed hydraulic pump. Failed main hydraulic pump drive.	Add recommended oil. Remove and inspect return filter for metal pump particles. Remove main hydraulic pump and inspect drive gear.
No hydraulic functions steering normal	Failed hydraulic pump. Failed line filter. Faulty safety valve. Stuck open system and port relief valve. Faulty or misadjusted pilot supply unit.	Remove and inspect return filter for metal pump particles, or replace the pump. Remove and inspect line filter for RCV. Safety valve leakage test or ON, OFF function test. Replace relief valve. Do pilot supply unit pressure test in group 3.
Boom float function does not work	Low pilot control pressure. Faulty pilot control valve (RCV). Main control valve spool binding in bore.	Do pilot supply unit pressure test in group 3. Do pilot control valve pressure test. Do pressure reducing valve pressure test.
One hydraulic function does not work.	Faulty pilot control valve (RCV). Stuck open port relief valve. Oil leaking past cylinder packings. Blockage in oil lines or valve. Main control valve spool stuck in bore.	Do pilot control valve pressure test. Replace relief valve. Do boom and bucket cylinder leakage test in group 3. Inspect lines for damage. Disconnect and inspect lines for internal blockage. Inspect and repair valve.
Low hydraulic power	Leakage within work circuit. Low system relief valve (main relief valve) setting. Low port relief valve setting. Faulty or misadjusted pilot oil supply unit . Leaking system relief valve. Worn hydraulic pump. Faulty pilot control valve (RCV).	Do cylinder drift check in group 3. Do loader system and port relief valve pressure test in group 3. Do loader system and port relief valve pressure test in group 3. Do pilot oil supply unit pressure test in group 3. Remove and inspect valve. Do hydraulic pump performance check . Do pilot control valve(RCV) pressure test in group 3.

7. MAIN CONTROL VALVE PRESSURE TEST (BACKHOE)

· SPECIFICATION

Oil temperature $45 \pm 5^{\circ}\text{C}$ ($113 \pm 9^{\circ}\text{F}$)

Relief valve	Engine speed	Relief pressure
System	High	$250 \pm 5 \text{ kgf/cm}^2$ ($3560 \pm 70 \text{ psi}$)
Boom raise (U) Boom down (W) Bucket rollback (R) Bucket dump (D) Dipper in (N) Dipper out (O)	Low	$280 \pm 5 \text{ kgf/cm}^2$ ($3980 \pm 70 \text{ psi}$)
Boom swing, LH/RH (S)	Low	$250 \pm 5 \text{ kgf/cm}^2$ ($3560 \pm 70 \text{ psi}$)

· GAUGE AND TOOL

Gauge 0~35 MPa (0~350 bar, 0~5000 psi)

- U : Boom raise relief valve
- W : Boom down relief valve
- R : Bucket rollback relief valve
- D : Bucket dump relief valve
- N : Dipper in relief valve
- O : Dipper out relief valve
- S : Boom swing relief valve

- 1) Install pressure gauge to plate in pump delivery line.
- 2) Install temperature reader.
(See temperature reader installation procedure in this group.)
- 3) Heat hydraulic oil to specifications.
(See hydraulic oil warm up procedure in this group.)
- 4) To check the system relief valve(M), run engine at high idle. Lower boom to bottomed position.
Slowly activate boom down function while watching pressure gauge. If pressure is not to specification, loosen lock nut on system relief valve(M) and adjust to specification.

※ Do not adjust the system relief valve above 250 kgf/cm^2 (3560 psi). Damage to the pump will result from excessive pressure settings.

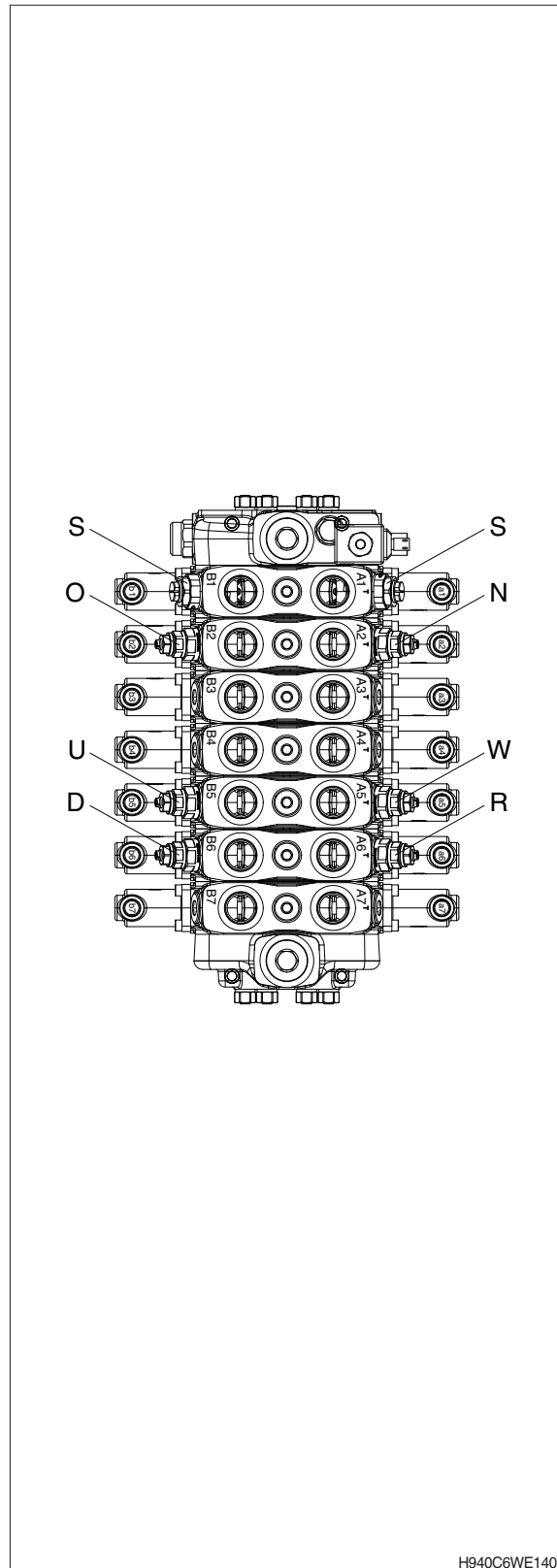

H940C6WE140

- ② Pull out driving gear & driven gear keeping gears as straight as possible.
- ③ Remove other pressure plate on rear side with same way for front side.

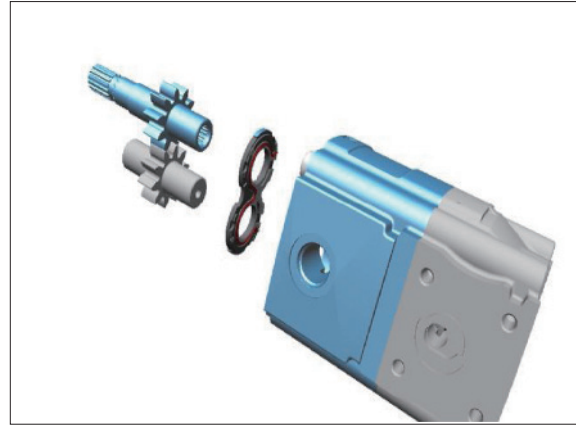

H940C6MP07

- ④ Remove square O-ring on the groove of body.
- ⑤ Remove through shaft and front body.
- ※ Tap around marked points with rubber mallet all around to break away first body from second.
Do not wedge between the bodies, it may give serious damage on the surface.

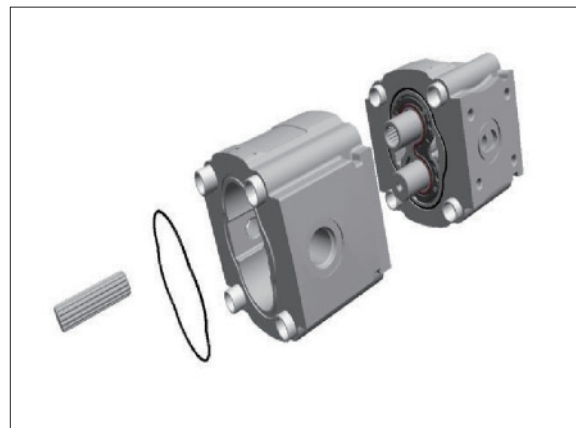

H940C6MP08

(4) 2nd working section

- ① Remove all components inside of second body with same way for 1st section.
- ② Remove the square O-ring if necessary.



H940C6MP09

- (6) Plug the other side of the spool cavity with M22×1.5 mm plug and tighten it to 4.28 kgf · m (31 lbf · ft) torque (wrench 12) using pneumatic torque gun. (Make sure that O-ring is present in the adapter.)

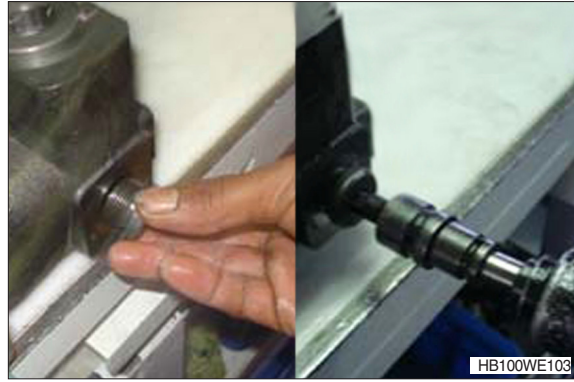

7) UNLOADING SOLENOID VALVE ASSEMBLY

- (1) Assemble the solenoid as shown in the picture and tighten it to 5.10 kgf · m (36.9 lbf · ft) torque (wrench 24) using pneumatic torque gun.

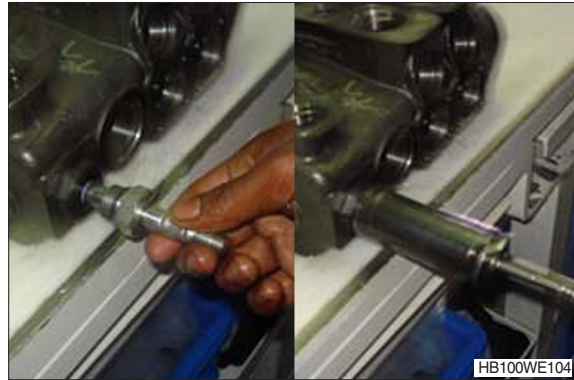

- (2) Insert the coil into the solenoid.
(3) Assemble the insulator.

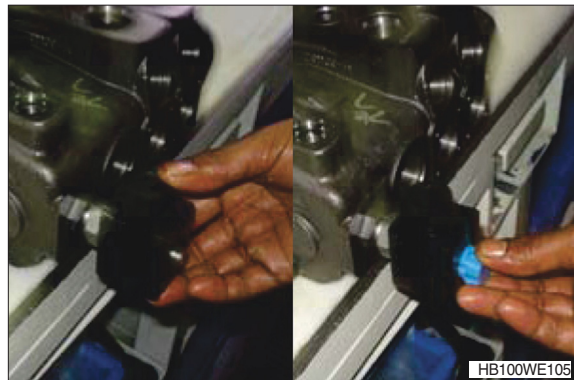

8) LS VALVE ASSEMBLY

- (1) Insert orifice of (∅ 1.25 mm) in the LS cavity as shown in picture.



Pilot control (3/3)

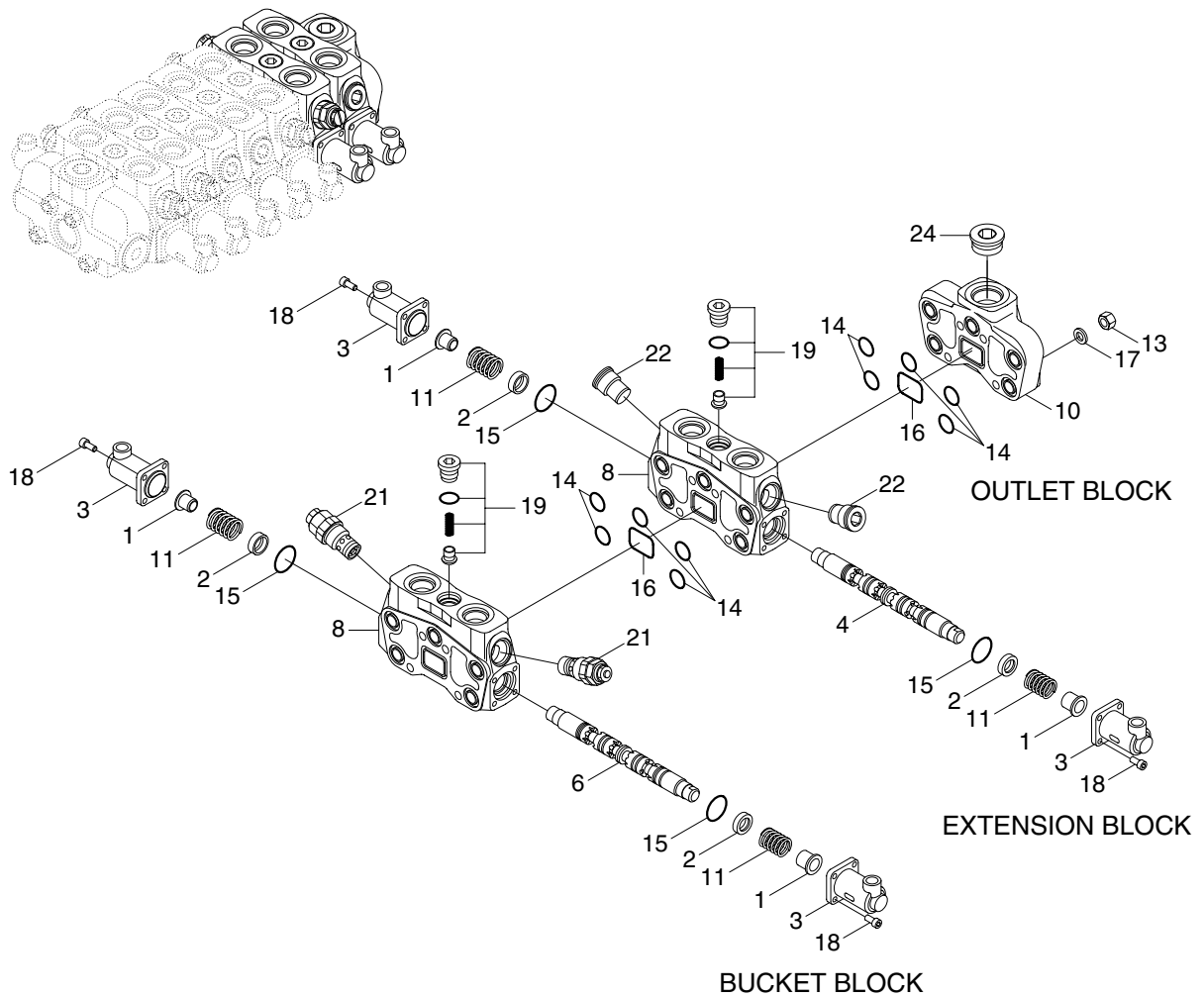

H940C6WE42

- | | | | | | |
|---|------------|----|--------------|----|---------------|
| 1 | Spring cap | 10 | Outlet cover | 17 | Spring washer |
| 2 | Bushing | 11 | Spring | 18 | Bolt |
| 3 | End cap | 13 | Nut | 19 | Check valve |
| 4 | Spool | 14 | O-ring | 21 | Relief valve |
| 6 | Spool | 15 | O-ring | 22 | Plug |
| 8 | Block | 16 | O-ring | 24 | Plug |

- (6) Loosen adjusting nut (21) and swash plate (20) with spanners on them respectively, and remove them.

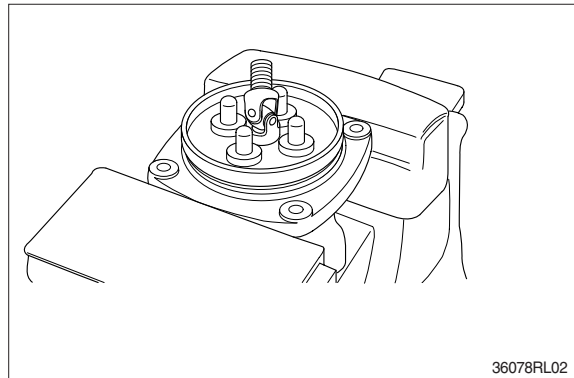
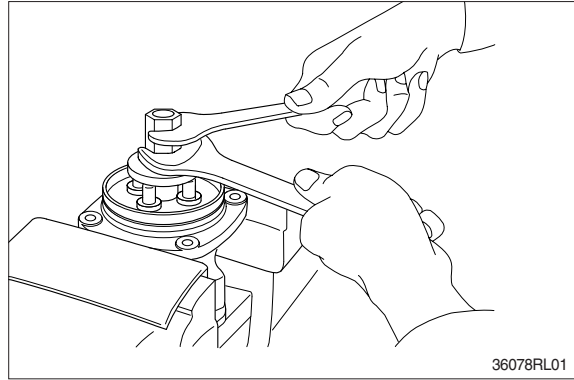

- (7) Turn joint anticlockwise to loosen it, utilizing jig (Special tool).

- ※ When return spring (10) is strong in force, plate (17), plug (14) and push rod (11) will come up on loosening joint. Pay attention to this.

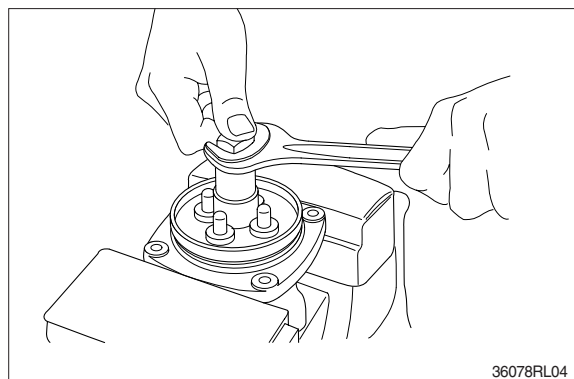
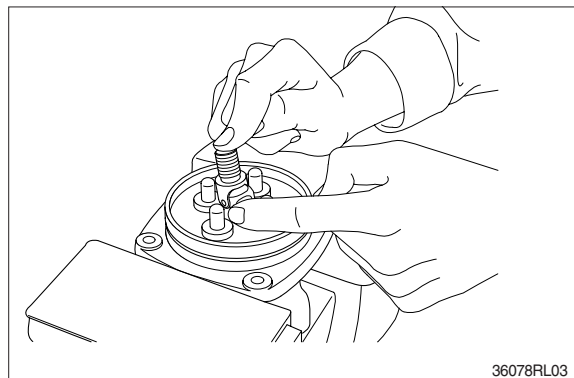

SECTION 7 ELECTRICAL SYSTEM

Group 1 Component Location	7-1
Group 2 Electrical Circuit	7-3
Group 3 Monitoring System	7-26
Group 4 Switches	7-31
Group 5 Electrical Component Specification	7-40
Group 6 Connectors	7-46

ILLUMINATION CIRCUIT

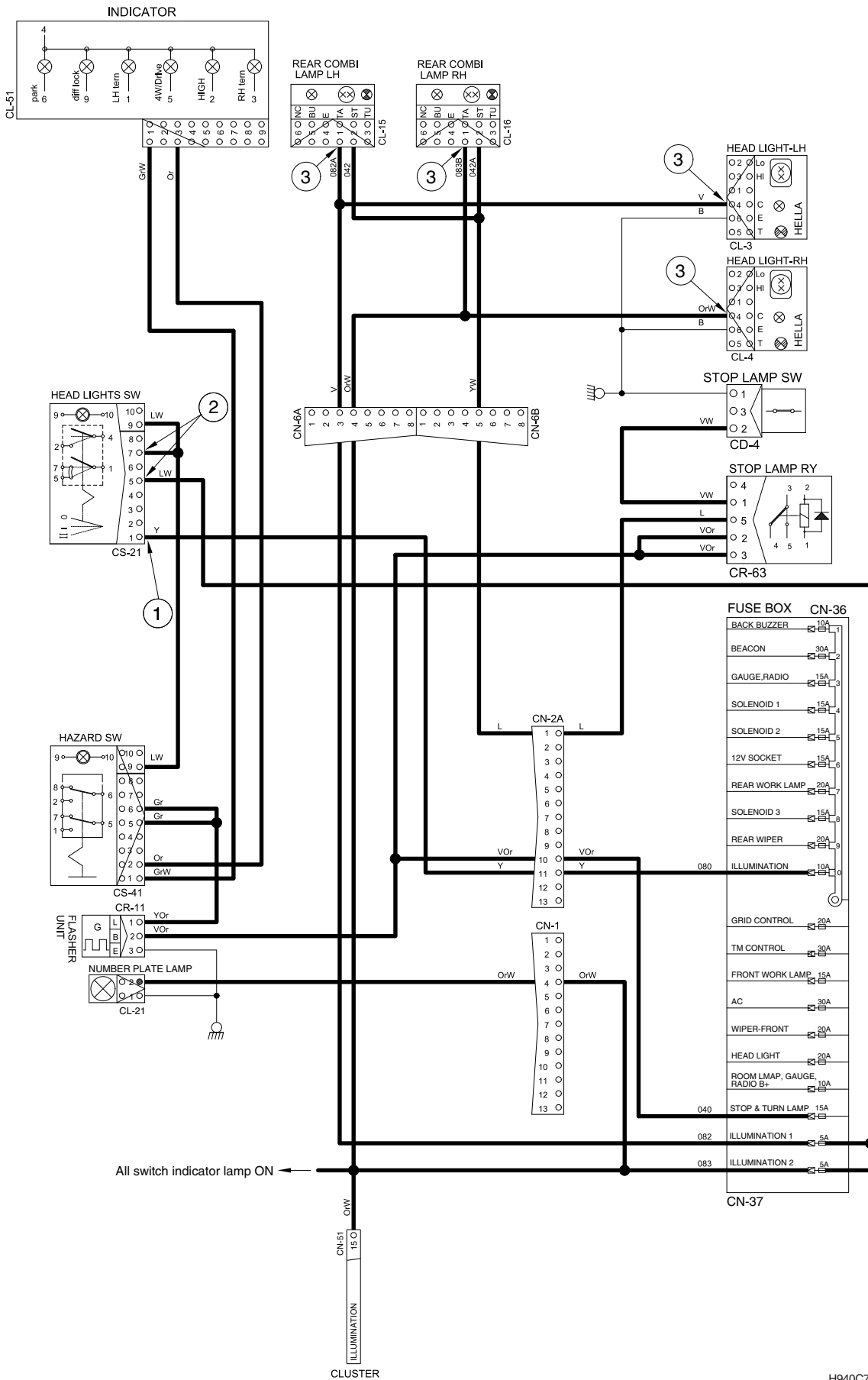

H940C7EL04

PREHEATING CIRCUIT

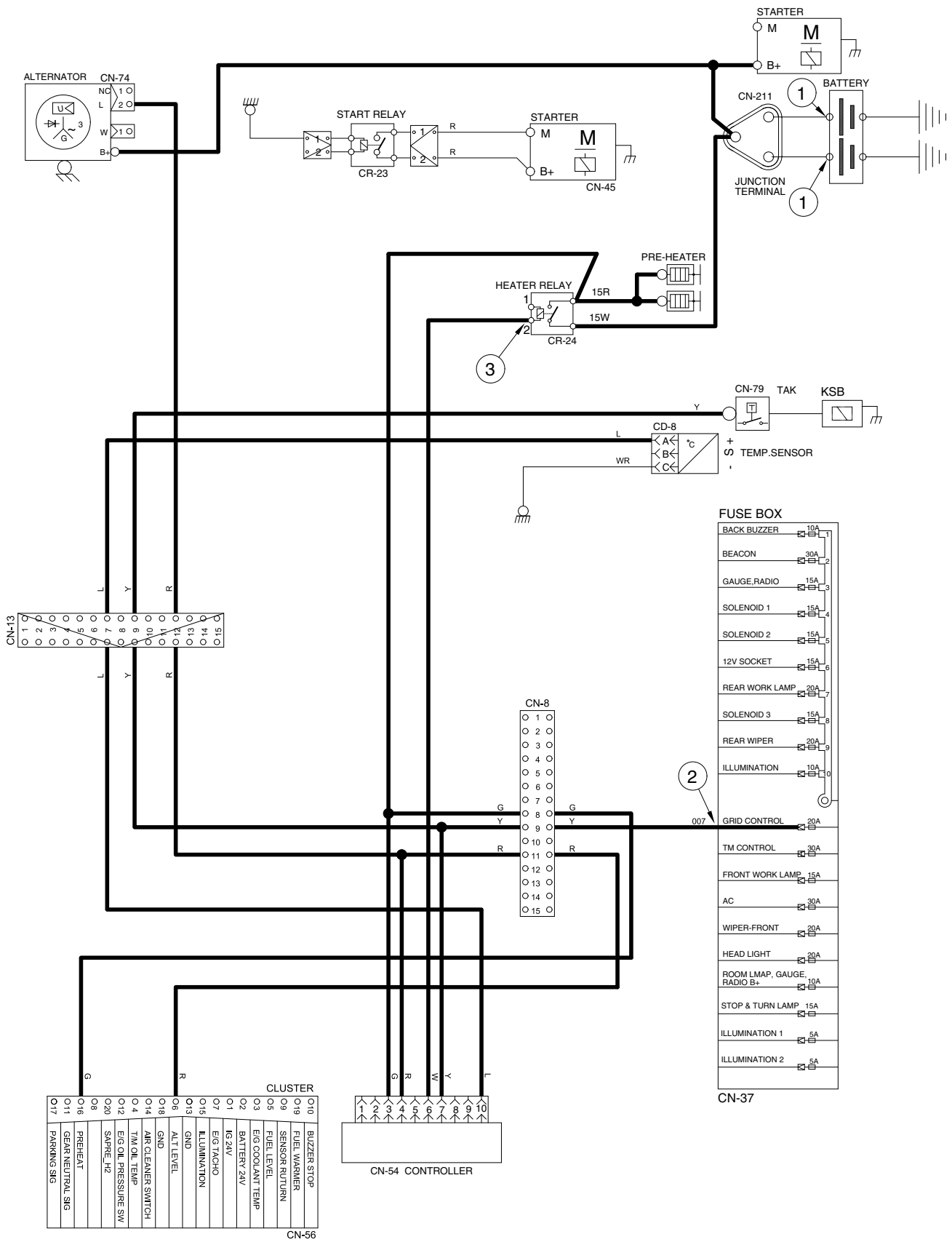

H940C7EL09

⑤ Air cleaner warning lamp

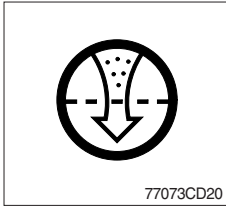

- This lamp lights ON when the filter of air cleaner is clogged.
- ※ Check the filter and clean or replace it when the lamp is ON.

⑥ Master warning lamp



⑦ Fuel level low warning lamp



Fill the fuel immediately when the lamp is turned ON.

Coolant temperature warning lamp

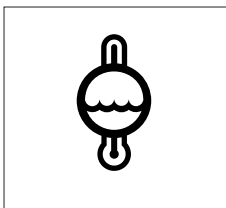

CLICK HERE TO **DOWNLOAD** THE COMPLETE MANUAL

- Thank you very much for reading the preview of the manual.
- You can download the complete manual from: www.heydownloads.com by clicking the link below



- Please note: If there is no response to CLICKING the link, please download this PDF first and then click on it.

CLICK HERE TO **DOWNLOAD** THE COMPLETE MANUAL