

SECTION 1 GENERAL

Group 1 Safety hints	1-1
Group 2 Specifications	1-4
Group 3 Periodic replacement	1-12

SECTION 2 REMOVAL & INSTALLATION OF UNIT

Group 1 Major components	2-1
Group 2 Removal and Installation of Unit	2-2

SECTION 3 POWER TRAIN SYSTEM

Group 1 Structure and operation	3-1
Group 2 Troubleshooting	3-4
Group 3 Disassembly and assembly	3-5

SECTION 4 BRAKE SYSTEM

Group 1 Structure and function	4-1
Group 2 Operational checks and troubleshooting	4-5
Group 3 Tests and adjustments	4-7

SECTION 5 STEERING SYSTEM

Group 1 Structure and function	5-1
Group 2 Operational checks and troubleshooting	5-10
Group 3 Disassembly and assembly	5-13

SECTION 6 HYDRAULIC SYSTEM

Group 1 Structure and function	6-1
Group 2 Operational checks and troubleshooting	6-16
Group 3 Disassembly and assembly	6-20

SECTION 7 ELECTRICAL SYSTEM

Group 1 Component location	7-1
Group 2 Electrical circuit	7-2
Group 3 Electric components	7-3

SECTION 8 MAST

Group 1 Structure	8-1
Group 2 Operational checks and troubleshooting	8-4
Group 3 Adjustment	8-7
Group 4 Removal and installation	8-10

CLICK HERE TO **DOWNLOAD** THE COMPLETE MANUAL

- Thank you very much for reading the preview of the manual.
- You can download the complete manual from: www.heydownloads.com by clicking the link below



- Please note: If there is no response to CLICKING the link, please download this PDF first and then click on it.

CLICK HERE TO **DOWNLOAD** THE COMPLETE MANUAL

GROUP 1 SAFETY HINTS

Careless performing of the easy work may cause injuries.

Take care to always perform work safely, at least observing the following.

- Oil is a dangerous substance. Never handle oil, grease or oily clothes in places where there is any fire or flame.

As preparation in case of fire, always know the location and directions for use of fire extinguishers and other fire fighting equipment.

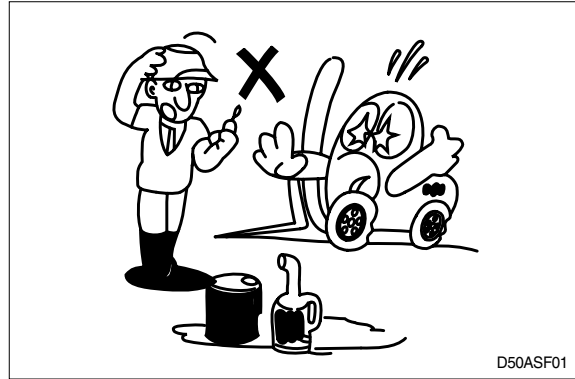

- Wear well-fitting helmet, safety shoes and working clothes. When drilling, grinding or hammering, always wear protective goggles. Always do up safety clothes properly so that they do not catch on protruding parts of machines. Do not wear oily clothes. When checking, always release battery plug.

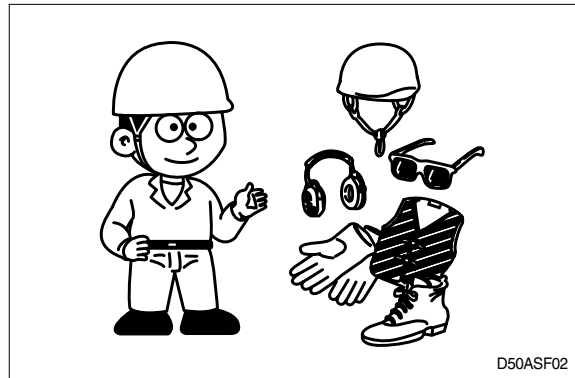

- Flames should never be used instead of lamps. Never use a naked flame to check leaks or the level of oil or electrolyte.

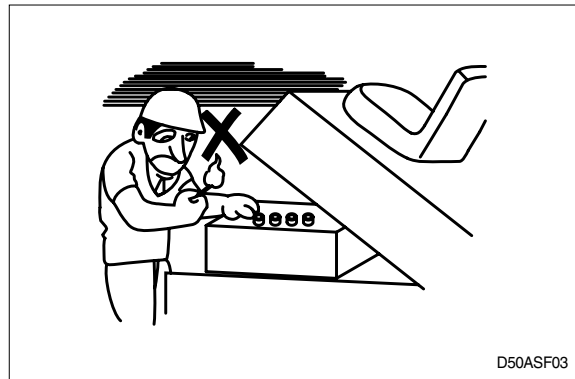

- When working on top of the machine, be careful not to lose your balance and fall.



6. RECOMMENDED LUBRICANTS

Use only oils listed below or equivalent.

Do not mix different brand oil.

Service point	Kind of fluid	Capacity l (U.S. gal)	Ambient temperature °C(°F)						
		22/25/30/32B-7	-20 (-4)	-10 (14)	0 (32)	10 (50)	20 (68)	30 (86)	40 (104)
Axle	Gear oil	2.4 (0.63)	Mobilfluid 424						
Hydraulic oil tank	Hydraulic oil	24 (6.3)	ISO VG 22						
			ISO VG 46						
			ISO VG 68						
Brake system	Brake oil	0.5 (0.1)	SAE 10W HYDRAULIC OIL (AZOLA ZS10)						
Fitting (Grease nipple)	Grease	0.1 (0.03)	NLGI No.1						
			NLGI No.2						

- API : American Petroleum Institute
- SAE : Society of Automotive Engineers
- ISO : International Organization for Standardization
- NLGI : National Lubricating Grease Institute

(4) Drive unit & motor assy

- ※ Drain the oil before disassembling the drive unit.
- ① Unscrew ten wheel nuts and remove the wheel.

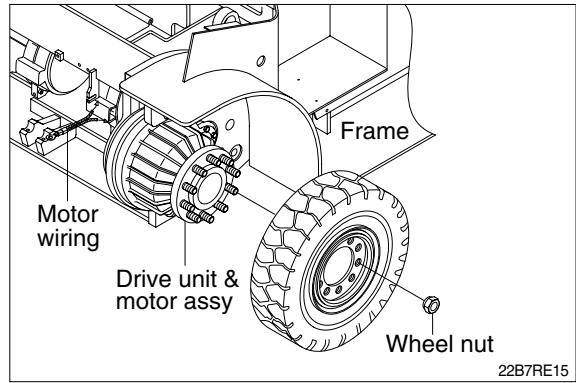

- ② Remove five socket bolts holding the drive motor in place.
- ③ Carefully remove the drive motor from the drive unit.

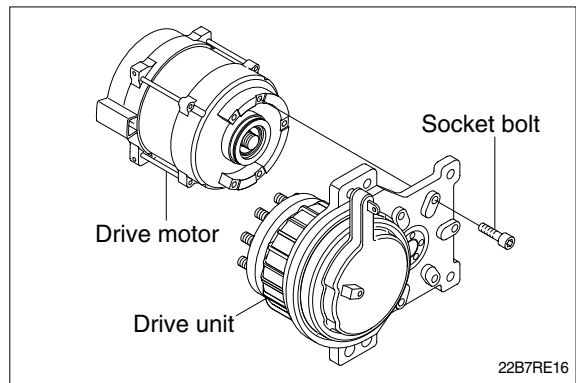

- ④ Loosen six mounting bolts on the truck frame and carefully take out the drive unit.

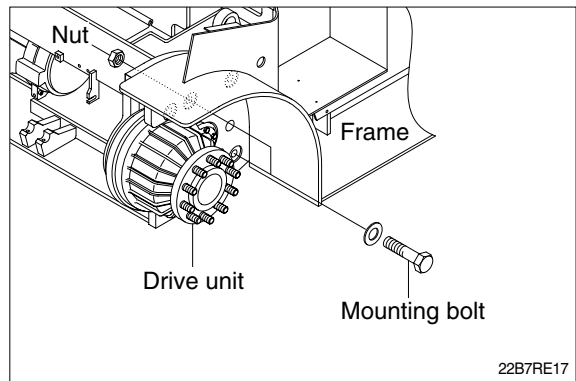

2) INSTALLATION

Installation is the reverse order of removal, but be careful of the following tightening torque.

· Tightening torque

Item	kgf · m	lbf · ft
Drive motor (1)	6 ~ 8	43.4 ~ 57.9
Drive unit (2)	53 ~ 58	383 ~ 420
Wheel nut (3)	12.5 ~ 15.5	90.4 ~ 112

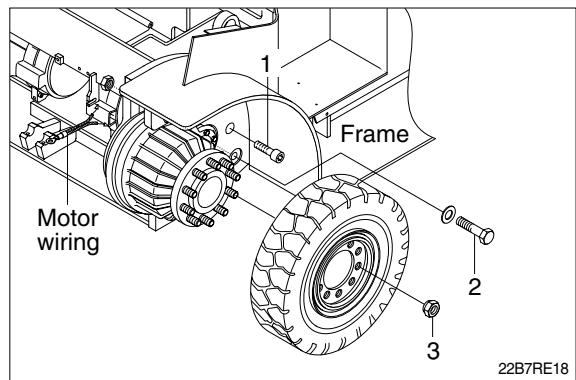

GROUP 3 DISASSEMBLY AND ASSEMBLY

1. DRIVE UNIT

1) DISASSEMBLY

(1) Drive unit assembly.

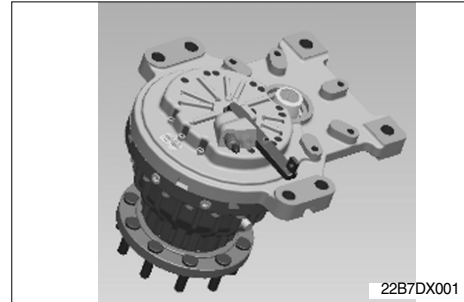

(2) Loosen the drain plug and drain oil.

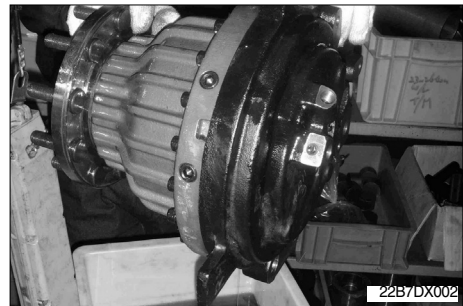

(3) Remove the housing bolt.

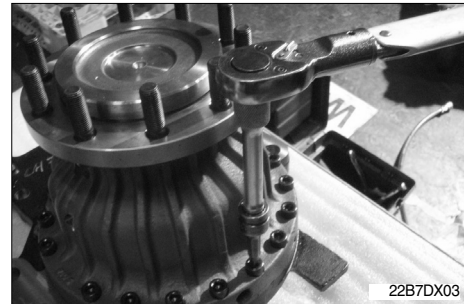

(4) Remove the cover from the housing.

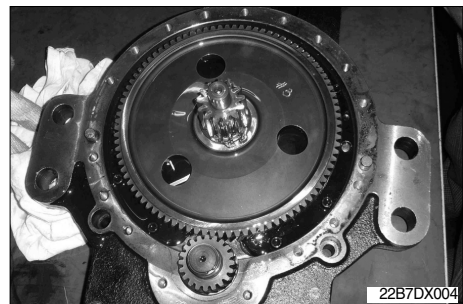

⑤ Assemble the needle bearing.

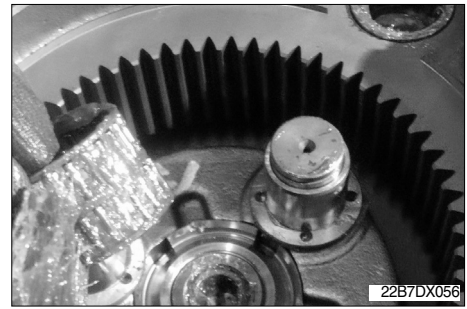

⑥ Needle bearing is now assembled.

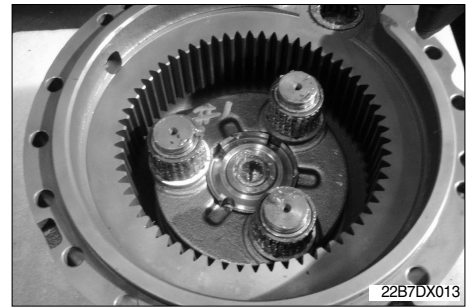

⑦ Assemble the planetary gear.



⑧ Assemble the washer.

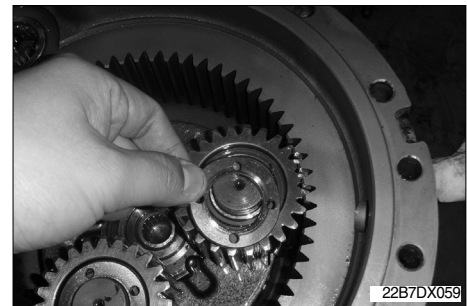

⑨ Assemble the retaining ring of planetary gear.

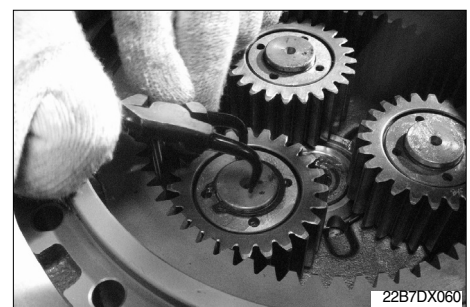

- ⑦ Apply the loctite #577 on the magnetic plug and assemble it.
· Tightening torque : 3.0~4.1kgf · m(21.7~29.7lb · ft)

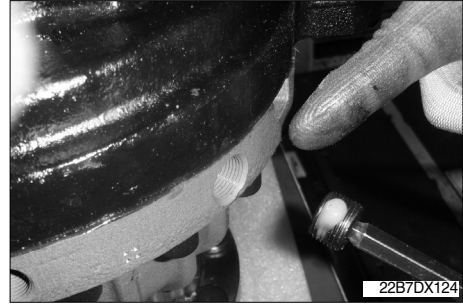

- ⑧ Apply the loctite #577 on the air breather and assemble it.

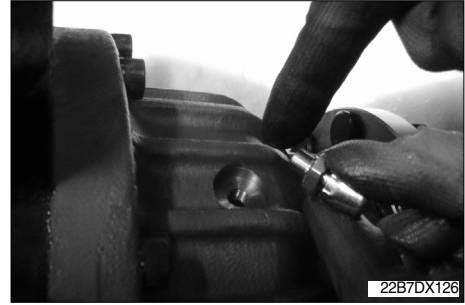

(5) Adjusting lever stroke

- ① Assemble the lever and pin.

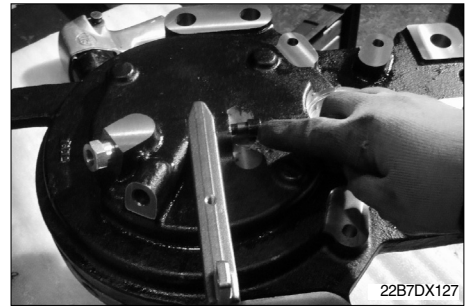

- ② Assemble the adapter for a pressure measurement.



GROUP 3 TESTS AND ADJUSTMENTS

1. BLEED THE BRAKE SYSTEM

The brake system must be bled after replenishing with brake fluid.

- 1) Remove cap from bleeding valve and fit proper hose to collect escaping brake fluid in a vessel.
- 2) Apply pressure by operating the brake pedal.
- 3) Open bleeding valve approx. half a turn with a spanner and press the brake pedal simultaneously to bleed the system.

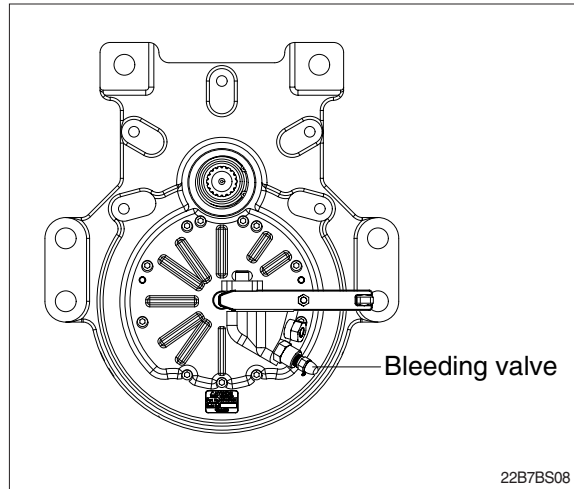

- ※ Collect escaping brake fluid into a suitable vessel.
Do not drain brake fluid into the soil or the gutters.

▲ Close the bleeding valve before releasing the brake pedal.

- ※ Repeat this procedure until the brake fluid escapes without bubbles.
Check the brake fluid container for sufficient fluid and refill if necessary.

- 4) When brake fluid escapes without bubbles tighten bleeding valve, remove hose and put dust protector onto the bleeding valve.
 - Tightening torque : 5kgf · m (37lbf · ft)

2. ADJUSTMENT OF PEDAL

1) BRAKE PEDAL

- (1) Pedal height from floor plate adjust with stopper bolt.
 - Pedal height : 140~145mm (5.5~5.7in)
- (2) Play
 - Adjust with rod of mast cylinder.
 - Pedal play : 8~12mm (0.3~0.5in)

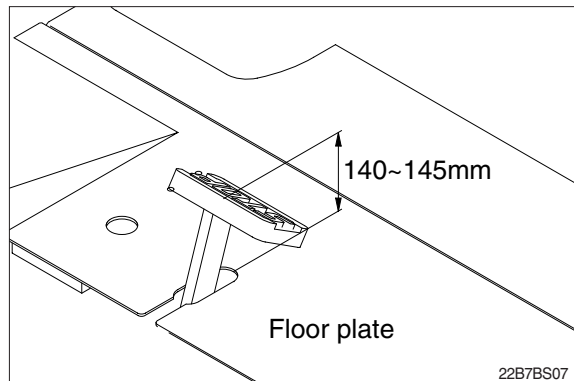

4. STEERING AXLE

1) Structure

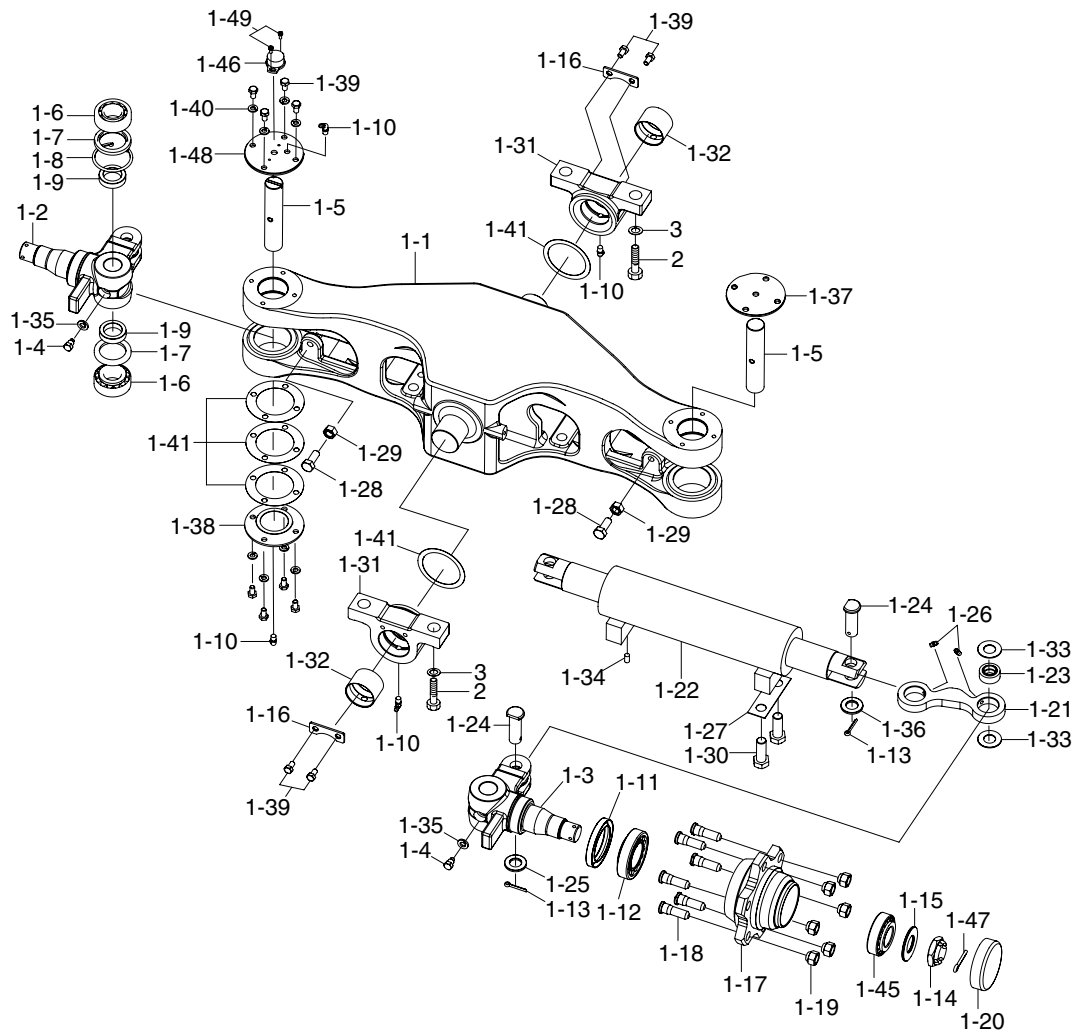

22B7SS06

1-1	Steering axle body	1-17	Hub	1-33	Thrust washer
1-2	Knuckle-RH	1-18	Hub bolt	1-34	Pin
1-3	Knuckle-LH	1-19	Hub nut	1-35	Spring washer
1-4	Bolt	1-20	Hub cap	1-36	Hardened washer
1-5	King pin	1-21	Steering link	1-37	Upper cover
1-6	Taper roller bearing	1-22	Steering cylinder assy	1-38	Lower cover
1-7	Oil seal	1-23	SPH plain bearing	1-39	Hex bolt
1-8	Snap ring	1-24	Steering link pin	1-40	Spring washer
1-9	Collar	1-25	Plain washer	1-41	Shim
1-10	Grease nipple	1-26	Grease nipple	1-45	Taper roller bearing
1-11	Oil seal	1-27	Lock plate	1-46	Potentiometer assy
1-12	Taper roller bearing	1-28	Hex bolt	1-47	Split pin
1-13	Split pin	1-29	Hex nut	1-48	Cover
1-14	Slotted nut	1-30	Hex bolt	1-49	W/Washer bolt
1-15	Washer	1-31	Trunnion block	2	Hex bolt
1-16	Plate	1-32	Bushing	3	Hardened washer

- (9) Take care to keep the cross pin in the sleeve and spool horizontal. The pin can be seen through the open end of the spool. Press the spool inwards and the sleeve, ring, bearing races and thrust bearing will be pushed out of the housing together.

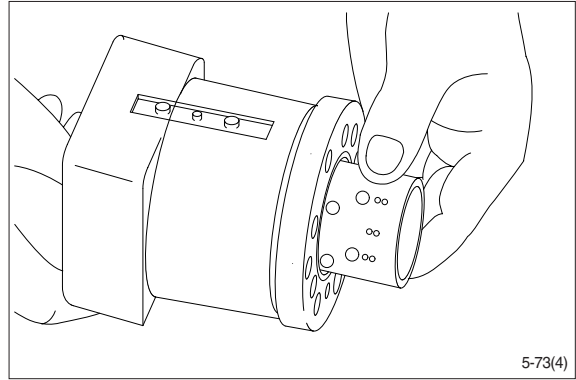

- (10) Take ring, bearing races and thrust bearing from sleeve and spool. The outer (Thin) bearing race can sometimes "stick" in the housing, therefore check that it has come out.

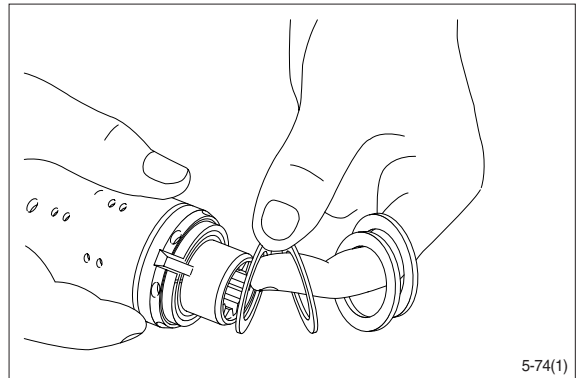

- (11) Press out the cross pin. Use the special screw from the end cover.

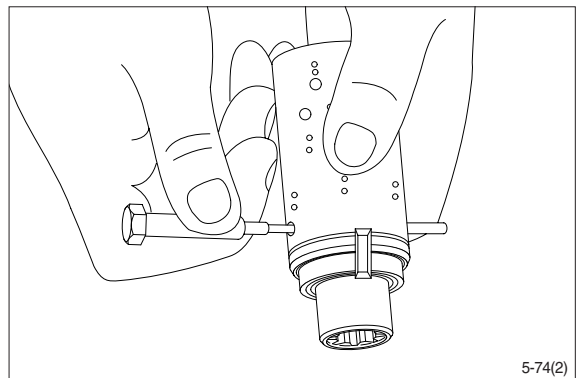

- ※ A small mark has been made with a pumice stone on both spool and sleeve close to one of the slots for the neutral position springs (See drawing). If the mark is not visible, remember to leave a mark of your own on sleeve and spool before the neutral position springs are disassembled.

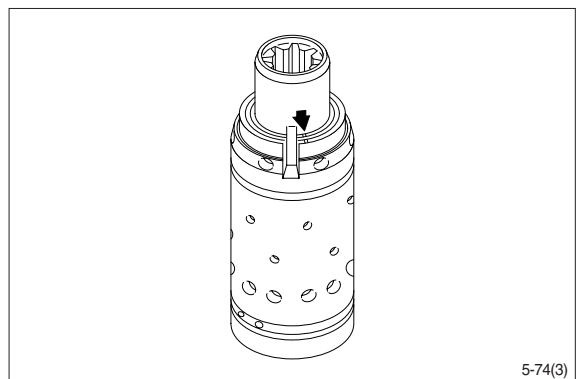

(25) Place the cardan shaft as shown - so that it is held in position by the mounting fork.

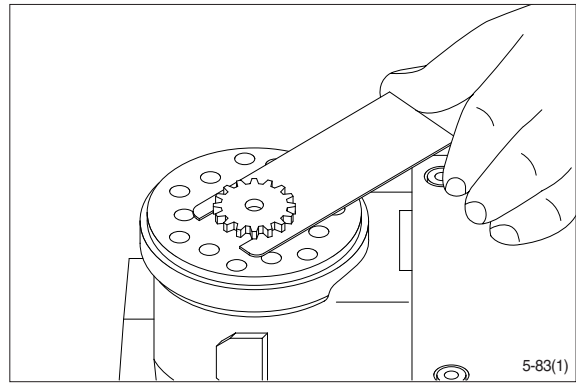

(26) Grease the two O-rings with mineral oil approx. viscosity 500 cSt at 20°C and place them in the two grooves in the gear rim. Fit the gearwheel and rim on the cardan shaft.

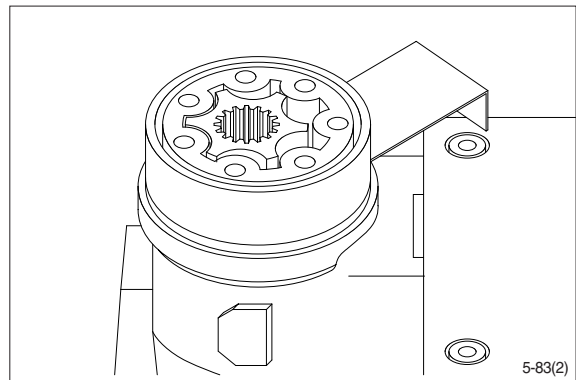

(27) Important

Fit the gearwheel(Rotor) and cardan shaft so that a tooth base in the rotor is positioned in relation to the shaft slot as shown.

Turn the gear rim so that the seven through holes match the holes in the housing.

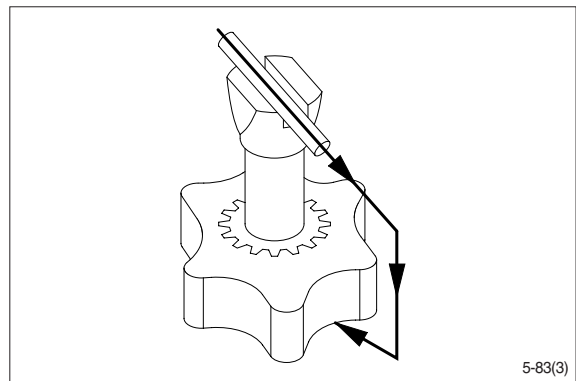

(28) Fit the spacer, if any.

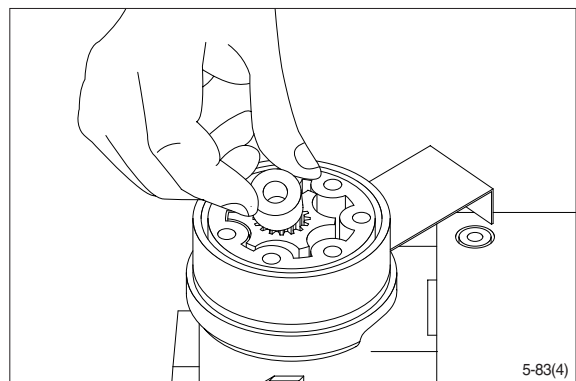

SECTION 6 HYDRAULIC SYSTEM

Group 1	Structure and function	6-1
Group 2	Operational checks and troubleshooting	6-16
Group 3	Disassembly and assembly	6-20

CLICK HERE TO **DOWNLOAD** THE COMPLETE MANUAL

- Thank you very much for reading the preview of the manual.
- You can download the complete manual from: www.heydownloads.com by clicking the link below



- Please note: If there is no response to CLICKING the link, please download this PDF first and then click on it.

CLICK HERE TO **DOWNLOAD** THE COMPLETE MANUAL

4) LIFT SECTION

(1) Operation

The lift section has a single work port to direct flow to the lift cylinder. Only one work port is used, because the lift cylinder is single-acting (gravity returns the mast to the lowered position).

The lift section also contains part of the components which comprise the safety features. There is a lift lock check valve. At the neutral position, pressures in the lock valve are equalized across the lift lock poppet. In this manner, the spring bias keeps the lift lock valve closed and prevents lowering of the mast.

① Lifting

When the operator shifts the lever backwards, the spool is extended out of the valve, and this opens the internal fluid passages that lift the mast. Oil flows through the high pressure parallel cavity, past the load check valve, through the spool metering notches, past the lift lock check valve, and to the head side of the lift cylinder.

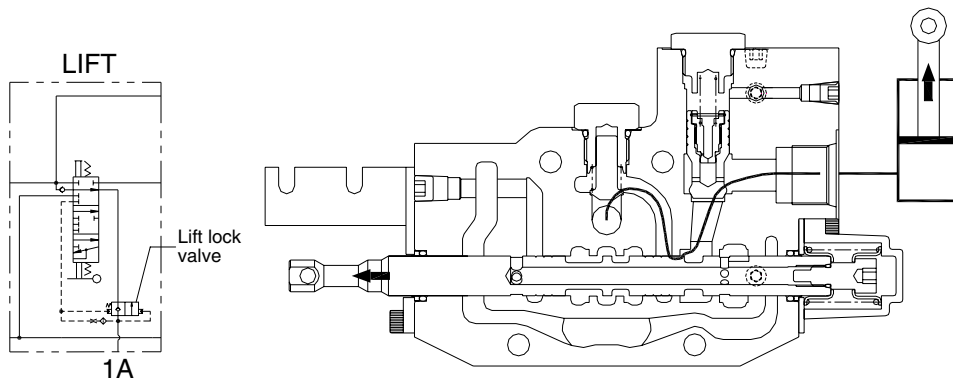

22B7HS11

② Lowering

When the seated operator shifts the lever forwards, the spool retracts into the valve, and the oil is directed from the cylinder, past the lift lock check valve, past the spool metering notches, and to the common tank cavity.

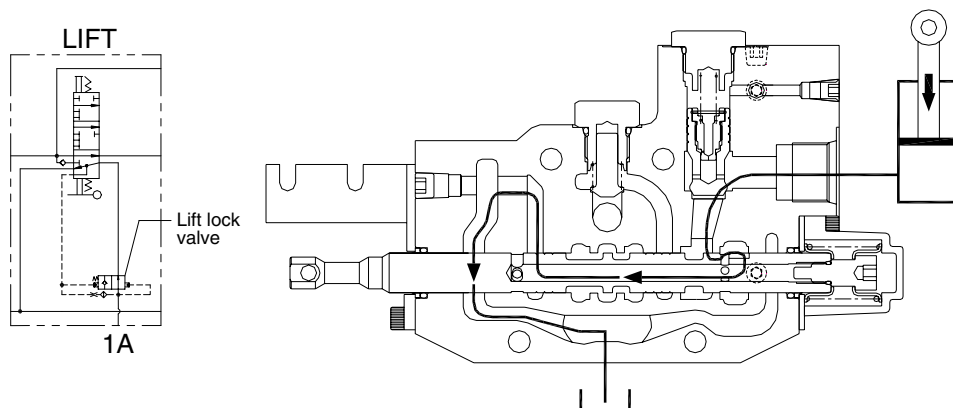

22B7HS12

Pressure is limited by the main relief valve.

GROUP 3 DISASSEMBLY AND ASSEMBLY

1. HYDRAULIC GEAR PUMP

1) DISASSEMBLY

- (1) Clean the pump externally with care.



22B7HS30

- (2) Loosen and remove the clamp bolts.
Coat the sharp edges of the drive shaft with adhesive tape and smear a clean grease on the shaft end extension to avoid any damaging lip of the shaft seal when removing the mounting flange.



22B7HS31

- (3) Remove the mounting flange taking care to keep the flange as straight as possible during removal.
If mounting flange is stuck, tap around the edge with rubber mallet in order to break away from the body.

※ Ensure that while removing mounting flange, shaft and other components remain position.



22B7HS32

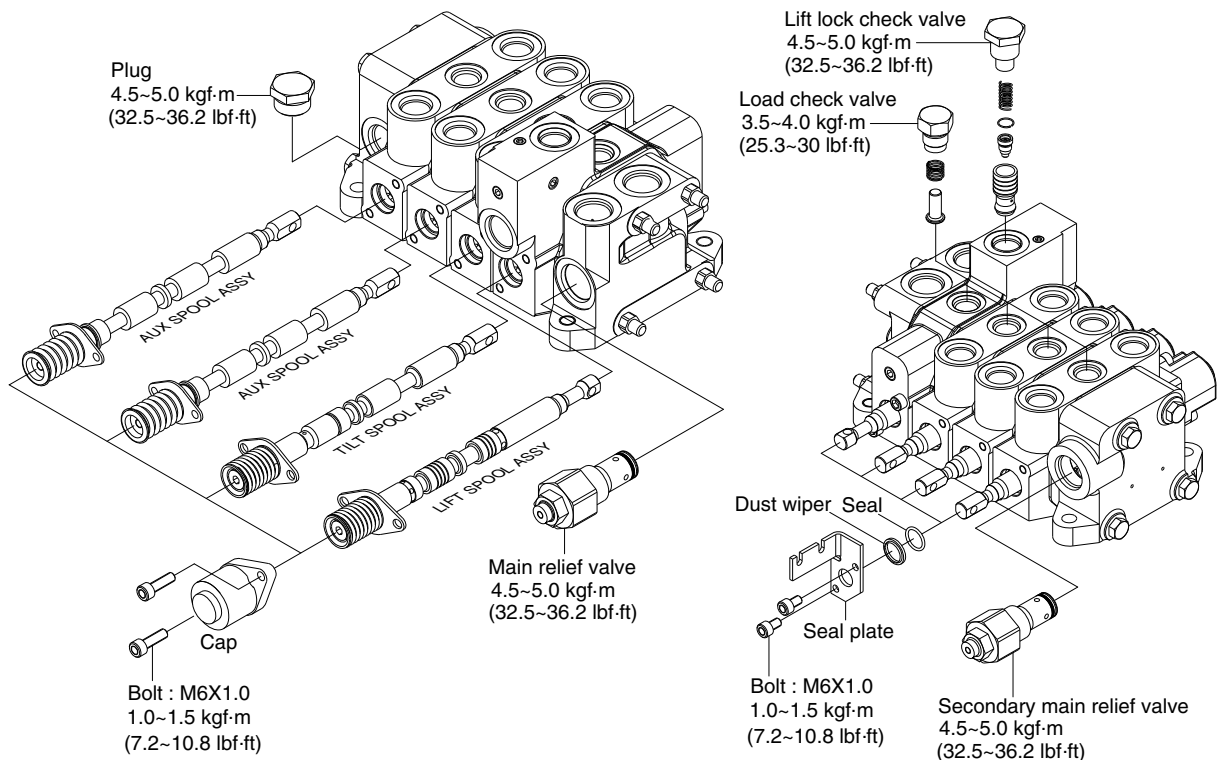

22B7HS25

(6) Auxiliary section

※ Same procedure for all aux sections, but spool assembly components may vary.

- ① The spool assembly should already consist of the proper aux spool, the return spring, one spring seat on either end of the spring, the seal plate, a spool seal, and a dust wiper. All of these are assembled on the end of the spool opposite the clevis.
- ② Insert the clevis end of the spool into the right-hand side of the spool bore (the tallest end of the housing). Place the spool cap over the spool and spring assembly and connect the cap to the housing using two bolts. Torque both bolts alternatively until a torque of 1.0~1.5 kgf · m (7.2~10.8 lbf · ft) is reached on both bolts.
- ③ Install the second spool seal and dust wiper over the clevis end of the spool and retain with a seal plate and two bolts. Torque both bolts alternatively until a torque of 1.0~1.5 kgf · m (7.2~10.8 lbf · ft) is reached on both bolts.
- ④ The load check assembly is inserted into the top center cavity. Torque to 3.5~4.0 kgf · m (25.3~30 lbf · ft).

(7) Outlet section

- ① Install the secondary main relief valve into the cavity on the clevis end of the housing. Torque to 4.5~5.0 kgf · m (32.5~36.2 lbf · ft)

2. BATTERY

1) STRUCTURE

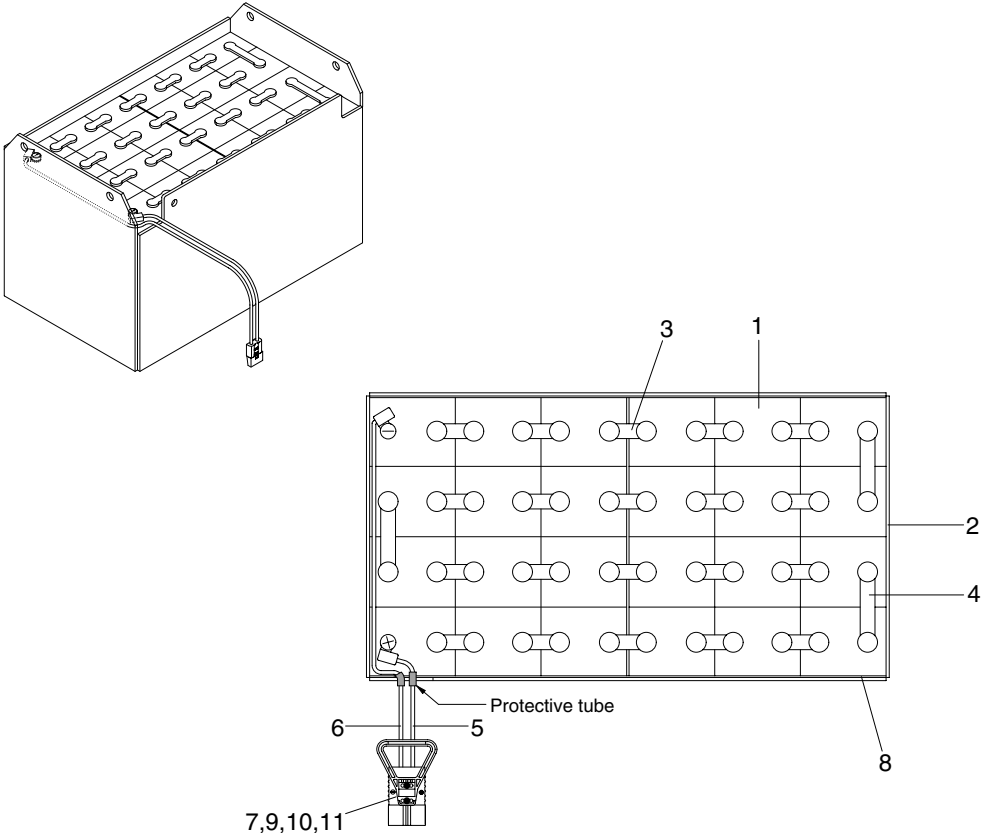

20B7EL03

- | | | | |
|---|------------------------|----|---------------|
| 1 | Cells | 7 | Plug |
| 2 | Steel box | 8 | Spacer |
| 3 | Cell connector | 9 | Handle (Red) |
| 4 | Row connector | 10 | Screw |
| 5 | Positive leading cable | 11 | Spring washer |
| 6 | Negative leading cable | | |

4. PUMP MOTOR

1) STRUCTURE

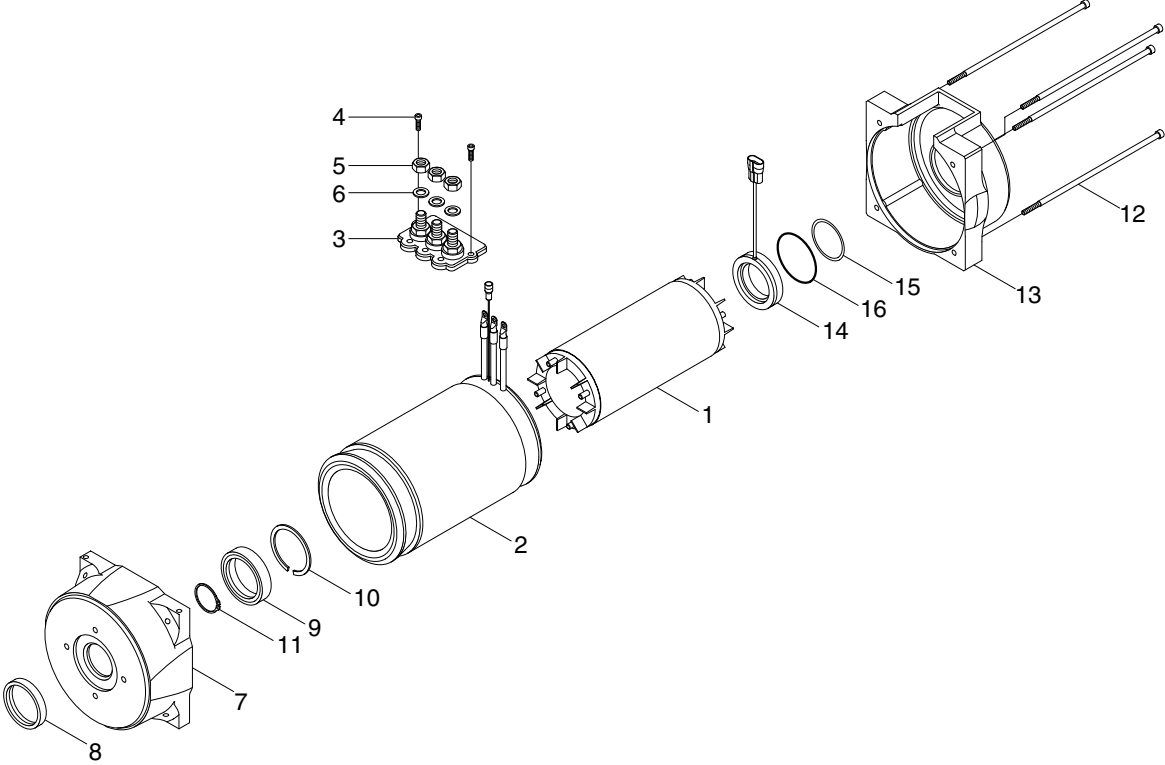

22B7EL08

- | | | |
|------------------|------------------------|-----------------------------|
| 1 Rotor | 7 End shield drive end | 12 Screw |
| 2 Stator | 8 Oil seal | 13 End shield non drive end |
| 3 Terminal | 9 Ball bearing | 14 Sensor bearing |
| 4 Screw | 10 Locking ring | 15 Spring washer |
| 5 Hexagon nut | 11 Locking ring | 16 O-ring |
| 6 Crinkle washer | | |

4) FUNCTION CONFIGURATION

■ TRACTION CONTROLLER-MASTER

Using the CONFIG MENU of the programming console, the user can configure the following functions (see "OPERATIONAL FEATURE" chapter for an explanation of "hydraulic steering function") :

(1) Submenu "SET OPTIONS"

① Hour counter

- RUNNING : The counter registers travel time only.
- KEY ON : The counter registers when the "key" switch is closed.

② Battery check

- ON : The battery discharge level check is carried out; when the battery level reaches 10%, an alarm is signalled and the maximum current is reduced to the half of the programmed value.
- OFF : The battery discharge level check is carried out but no alarm is signalled.

③ Traction cutout

When the alarm "BATTERY LOW" appears, if this option is programmed to ON the traction maximum speed is reduced to 60Hz.

④ Lift cutout

When the alarm "BATTERY LOW" appears, if this option is programmed to ON the lift function is disabled.

⑤ S.R.O.

If this option is set to on the static return to off is requested for starting the truck. The required sequence is :

- Seat-direction lever-accelerator pedal or :
- Seat-accelerator pedal-direction lever within the seq. delay time
If this option is set to off the required sequence to start the truck is :
- Direction lever-accelerator pedal or :
- Accelerator pedal-direction lever within the seq. delay time

⑥ Hydro key on

- ON / OFF : If this option is programmed ON the traction inverter manages an hydraulic steering function when the "key" is switched ON.

⑦ Stop on ramp

- ON : The stop on ramp feature (truck electrically hold on a ramp) is managed for a fixed time (6 sec.).
- OFF: The stop on ramp feature is not performed.

⑧ Aux input #1

- EXCLUSIVE HYDRO : Input C10 activates hydraulic steering function, output A31 is activated.
- OPTION #1 : Input C10 is the input for an handbrake device, active low (open switch).
- OPTION #2 : Input C10 is the input for a speed reduction device, active low (open switch).

⑨ Pedal braking

- DIGITAL : The truck does not have a potentiometer installed on the mechanical brake pedal, but only a switch; when the accelerator pedal is released and the brake pedal is pushed (brake switch closed), the inverter performs an electrical braking following "Pedal braking" parameter.

(3) Description of the console SAVE function

The SAVE function allows the operator to transmit the parameter values and configuration data of the chopper into the console memory. It is possible to load 64 different programmers.

The information saved in the console memory can then be reloaded into another chopper using the RESTORE function.

The data that is available via the SAVE function is as follows:

- All parameter values (Parameter change).
- Options (Set. options).

Flow chart showing how to use the SAVE function of the digital console.

- ① Opening Zapi display.
- ② Press ENTER to go into the general menu.
- ③ The display will show:
- ④ Press ROLL UP or ROLL DOWN button until SAVE PARAM. appear on the display.
- ⑤ The display shows:
- ⑥ Press ENTER to go into the SAVE function.
- ⑦ If this facility has been used before the type of chopper data stored appears on the top main with a 2 digit reference.
- ⑧ Keep pressing either ROLL UP or ROLL DOWN keys until the second Main indicates a FREE storage facility.
- ⑨ Press ENTER to commence SAVE routine.
- ⑩ You can see the items that are being stored whilst the SAVE routine is happening.
- ⑪ When finished, the console shows :
- ⑫ Press OUT to return to the opening Zapi display.

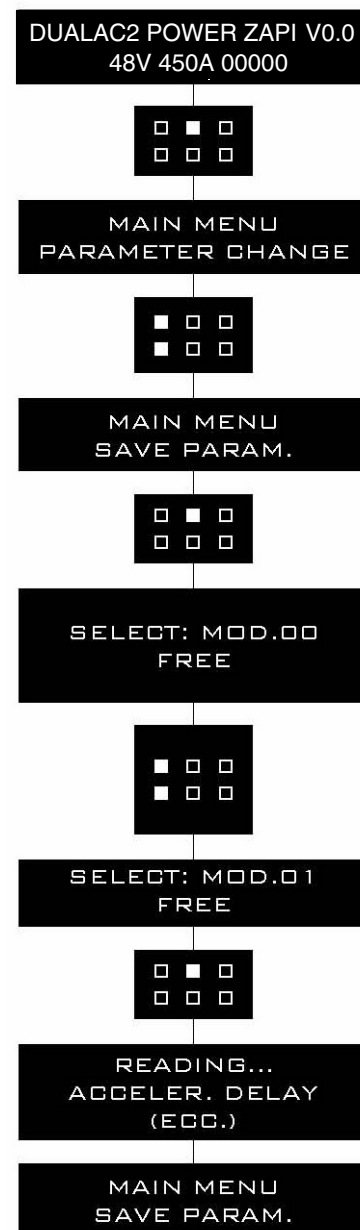

6. DISPLAY

1) STRUCTURE

The instrument panel has six built-in red LED, which provide the operator with an easy information about the status of some truck devices.

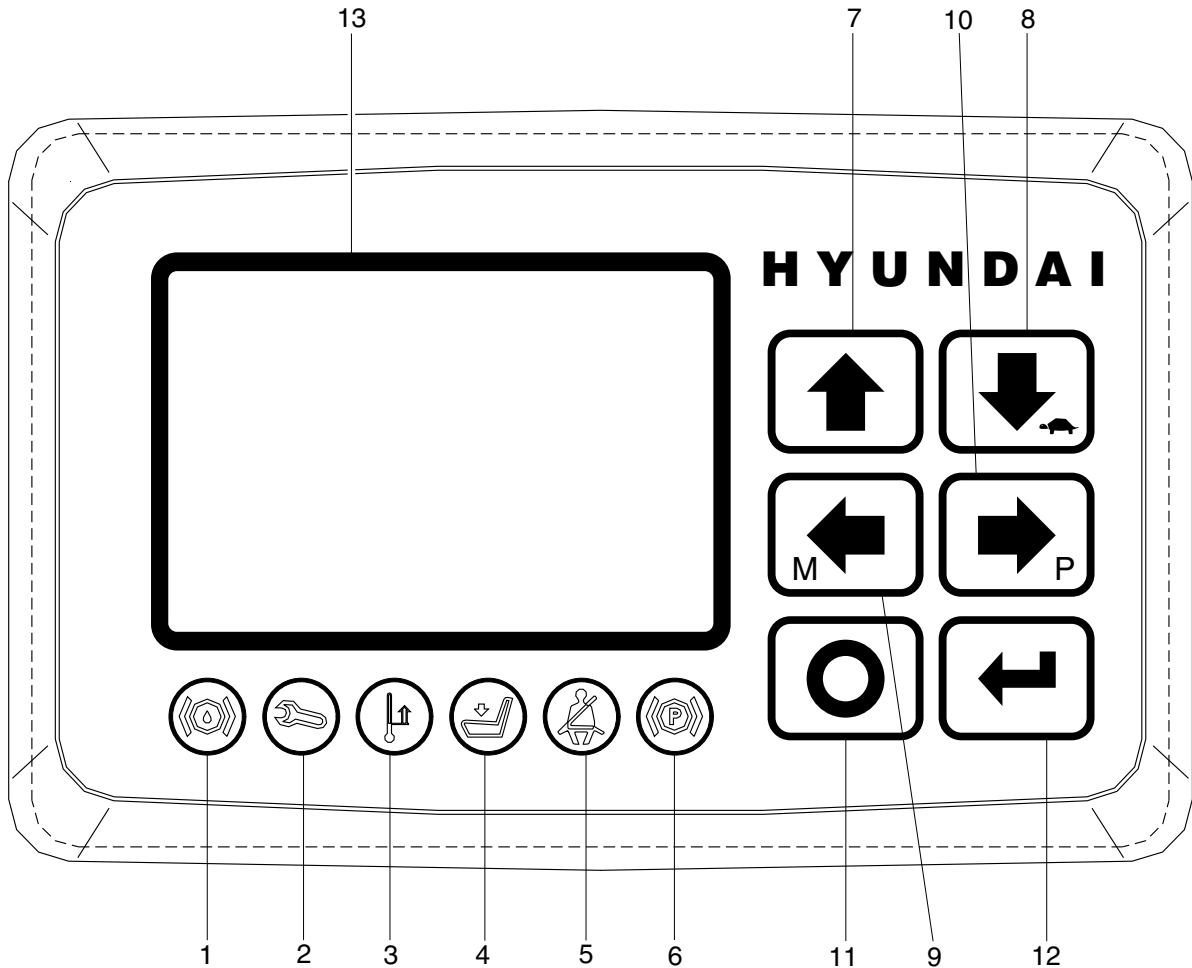

15B70M65

- | | | | |
|---|---------------------------------|----|--------------|
| 1 | Oil level warning lamp (option) | 8 | Key 2 button |
| 2 | Wrench warning lamp | 9 | Key 3 button |
| 3 | Thermometer warning lamp | 10 | Key 4 button |
| 4 | Seat warning lamp | 11 | Key 5 button |
| 5 | Seat belt warning lamp (option) | 12 | Key 6 button |
| 6 | Handbrake warning lamp | 13 | LCD function |
| 7 | Key 1 button | | |

7) DESCRIPTION OF ALARM MENU

The microprocessor in the controller records the last five alarms that have occurred. Items remembered relative to each alarm are: the code of the alarm, the number of times the particular alarm occurred and the hour meter count. This function permits deeper diagnosis of problems as the recent history can now be accessed.

Flow chart showing how to use the ALARMS function via the digital console:

- ① Opening Zapi menu.
- ② Press ENTER to go into the MAIN MENU.
- ③ The display will show:
- ④ Press ROLL UP or ROLL DOWN until ALARMS menu appears on the display.
- ⑤ The display will show:
- ⑥ Press ENTER to go into the ALARMS menu.
- ⑦ The display will show the most recent alarm.
- ⑧ Each press of ROLL UP button brings up following alarms. Pressing ROLL DOWN returns to the most recent.
- ⑨ If an alarm has not occurred, the display will show: NONE.
- ⑩ When you have finished looking at the alarms, press OUT to exit the ALARMS menu.
- ⑪ The display will ask: "CLEAR LOGBOOK?" Press ENTER for Yes, or OUT for No.
- ⑫ Press OUT again and return to opening Zapi menu.

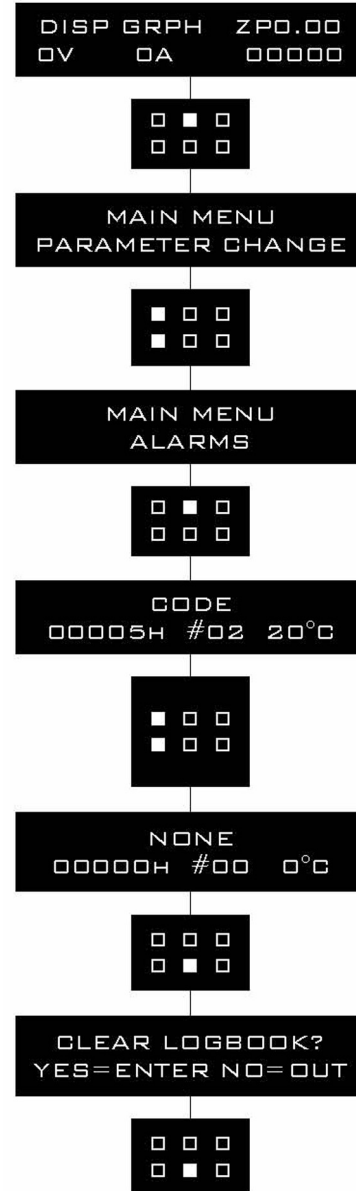

20B7EL31

Code	Alarm string	Master	Slave	Pump	Description	Condition that has to occur to come out from alarm status
251	WAITING FOR NODE	X			Warning: Master μ C signals that slave or pump μ C is in alarm status	To remove warning cause
251	WAITING FOR NODE#3		X		Warning: Slave μ C signals that master μ C is in alarm status	To remove warning cause
247	NO CAN MESSAGE #X	X	X		Alarm: Master/Slave has lost Can communication with #X	To remove Alarm cause
250	CANBUS KO			X	Alarm: Inverter has lost Can communication	To remove Alarm cause
240	MOTOR STALL	X			Warning: The encoder signal is constantly zero when the maximum torque is applied to the motor	To recycle the key
243	SEQUENCE FAULT	X			Warning: An incorrect start sequence has been detected on the seat, pedal and levers commands	To remove warning cause
254	CANBUS KO DISP.	X			Alarm: Master has lost can communication with the display	
252	CHAT MODE	X			Warning: The chat time has expired	To activate traction or pump request
248	DISPLAY ENABLE	X			Warning: The display enable signal has not been received to operate the truck	To remove warning cause
242	PUMP WARNING	X			Warning: A warning is active on the pump module	To remove warning cause
242	MOTOR STALL			X	Warning: The encoder signal is constantly zero or opposite to applied frequency when the maximum torque is applied to the motor	To recycle the key
244	SLAVE WARNING	X			Warning: A warning is active on the pump module	To remove warning cause

(2) Troubleshooting

① Only floating charge lamp is on after indicating "A.O", It's not charged.

- 220/380V Model : Measure the voltage between input voltage change over tabs 2-4 2-6 4-6
- 220,380,410,440V Model : Measure the voltage in front of AC INPUT MS S/W



In front of MS

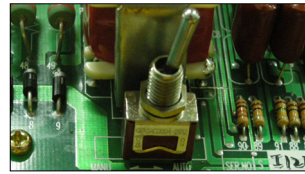

Manual/Auto TAP Changer

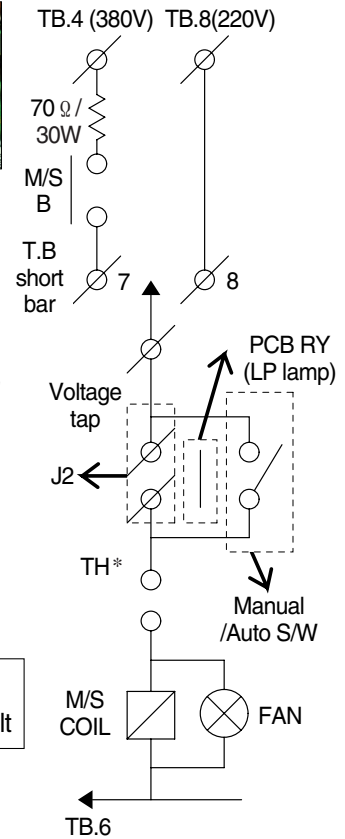

M/S electrical circuit

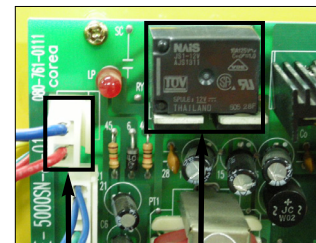
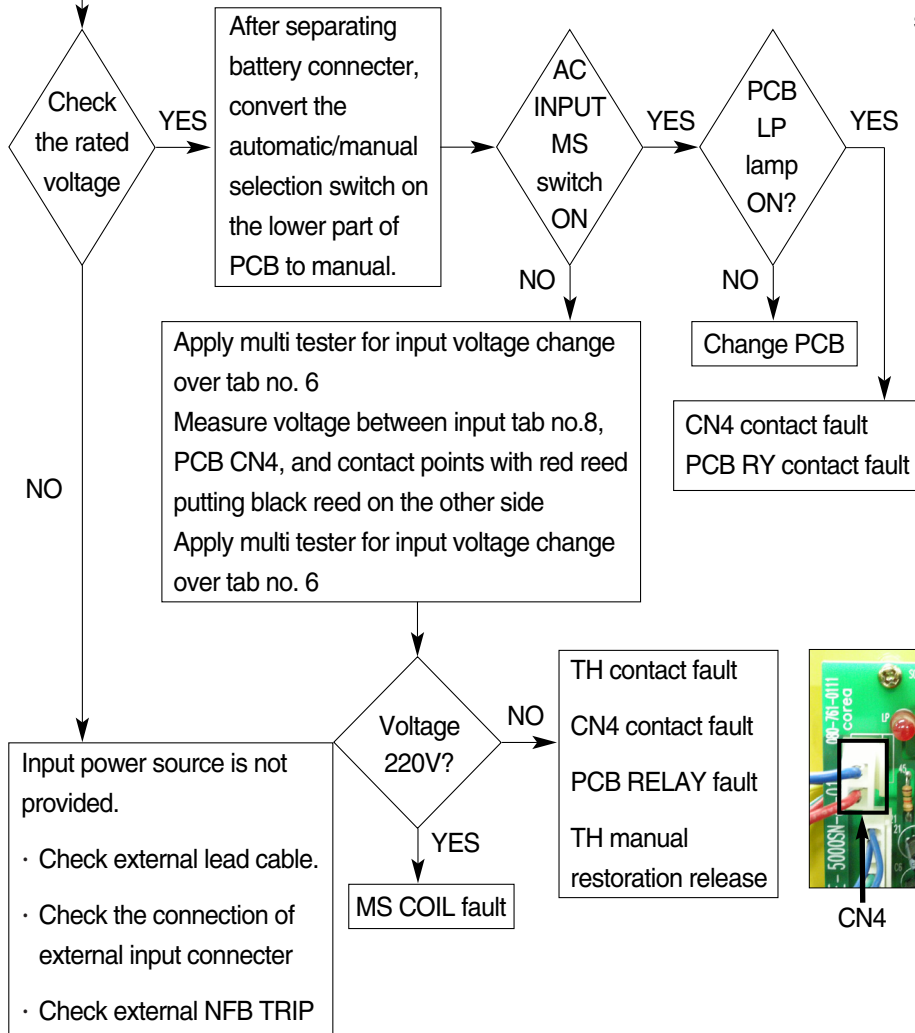

CN4

RY

2. 3 STAGE MAST(TF MAST)

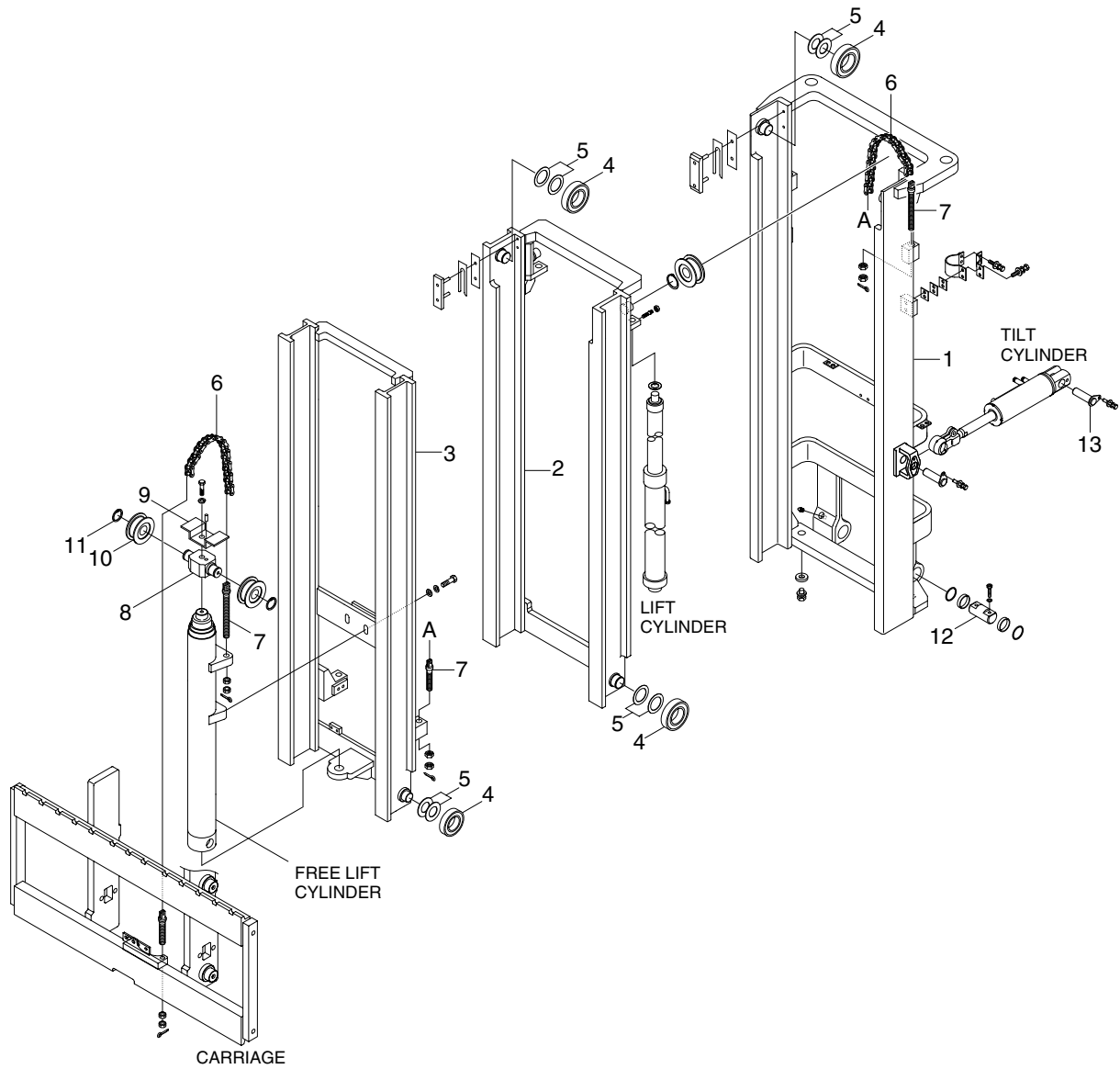

22B7MS02

- | | | | | | |
|---|-----------------|---|----------------|----|-------------------|
| 1 | Outer mast | 6 | Lift chain | 10 | Chain sheave |
| 2 | Middle mast | 7 | Anchor bolt | 11 | Retaining ring |
| 3 | Inner mast | 8 | Sheave bracket | 12 | Mast mounting pin |
| 4 | Roller | 9 | Chain guard | 13 | Tilt cylinder pin |
| 5 | Shim(0.5, 1.0t) | | | | |

CLICK HERE TO **DOWNLOAD** THE COMPLETE MANUAL

- Thank you very much for reading the preview of the manual.
- You can download the complete manual from: www.heydownloads.com by clicking the link below



- Please note: If there is no response to CLICKING the link, please download this PDF first and then click on it.

CLICK HERE TO **DOWNLOAD** THE COMPLETE MANUAL