

SECTION 1 GENERAL

Group 1 Safety hints	1-1
Group 2 Specifications	1-5
Group 3 Periodic replacement	1-18

SECTION 2 REMOVAL AND INSTALLATION OF UNIT

Group 1 Structure	2-1
Group 2 Removal and installation of unit	2-2
Group 3 Maintenance for hose	2-21

SECTION 3 POWER TRAIN SYSTEM

Group 1 Structure and operation	3-1
Group 2 Disassembly and assembly	3-17
Group 3 Maintenance and troubleshooting	3-69

SECTION 4 BRAKE SYSTEM

Group 1 Structure and function	4-1
Group 2 Operational checks and troubleshooting	4-18
Group 3 Tests and adjustments	4-20
Group 4 Disassembly and assembly	4-23

SECTION 5 STEERING SYSTEM

Group 1 Structure and function	5-1
Group 2 Operational checks and troubleshooting	5-12
Group 3 Disassembly and assembly	5-14

SECTION 6 HYDRAULIC SYSTEM

Group 1 Structure and function	6-1
Group 2 Operational checks and troubleshooting	6-28
Group 3 Disassembly and assembly	6-33

SECTION 7 ELECTRICAL SYSTEM

Group 1 Component location	7-1
Group 2 Electrical circuit	7-3
Group 3 Cluster	7-18
Group 4 Component specification	7-56
Group 5 Connector destination	7-57
Group 6 Troubleshooting	7-60

CLICK HERE TO **DOWNLOAD** THE COMPLETE MANUAL

- Thank you very much for reading the preview of the manual.
- You can download the complete manual from: www.heydownloads.com by clicking the link below



- Please note: If there is no response to CLICKING the link, please download this PDF first and then click on it.

CLICK HERE TO **DOWNLOAD** THE COMPLETE MANUAL

TEMPERATURE

Fahrenheit-Centigrade Conversion.

A simple way to convert a fahrenheit temperature reading into a centigrade temperature reading or vice verse is to enter the accompanying table in the center or boldface column of figures.

These figures refer to the temperature in either Fahrenheit or Centigrade degrees.

If it is desired to convert from Fahrenheit to Centigrade degrees, consider the center column as a table of Fahrenheit temperatures and read the corresponding Centigrade temperature in the column at the left.

If it is desired to convert from Centigrade to Fahrenheit degrees, consider the center column as a table of Centigrade values, and read the corresponding Fahrenheit temperature on the right.

°C	°F	°C	°F	°C	°F	°C	°F	°C	°F	°C	°F
-40.4	-40	-40.0	-11.7	11	51.8	7.8	46	114.8	27.2	81	117.8
-37.2	-35	-31.0	-11.1	12	53.6	8.3	47	116.6	27.8	82	179.6
-34.4	-30	-22.0	-10.6	13	55.4	8.9	48	118.4	28.3	83	181.4
-31.7	-25	-13.0	-10.0	14	57.2	9.4	49	120.2	28.9	84	183.2
-28.9	-20	-4.0	-9.4	15	59.0	10.0	50	122.0	29.4	85	185.0
-28.3	-19	-2.2	-8.9	16	60.8	10.6	51	123.8	30.0	86	186.8
-27.8	-18	-0.4	-8.3	17	62.6	11.1	52	125.6	30.6	87	188.6
-27.2	-17	1.4	-7.8	18	64.4	11.7	53	127.4	31.1	88	190.4
-26.7	-16	3.2	-6.7	20	68.0	12.8	55	131.0	32.2	90	194.0
-26.1	-15	5.0	-6.7	20	68.0	12.8	55	131.0	32.2	90	194.0
-25.6	-14	6.8	-6.1	21	69.8	13.3	56	132.8	32.8	91	195.8
-25.0	-13	8.6	-5.6	22	71.6	13.9	57	134.6	33.3	92	197.6
-24.4	-12	10.4	-5.0	23	73.4	14.4	58	136.4	33.9	93	199.4
-23.9	-11	12.2	-4.4	24	75.2	15.0	59	138.2	34.4	94	201.2
-23.3	-10	14.0	-3.9	25	77.0	15.6	60	140.0	35.0	95	203.0
-22.8	-9	15.8	-3.3	26	78.8	16.1	61	141.8	35.6	96	204.8
-22.2	-8	17.6	-2.8	27	80.6	16.7	62	143.6	36.1	97	206.6
-21.7	-7	19.4	-2.2	28	82.4	17.2	63	145.4	36.7	98	208.4
-21.1	-6	21.2	-1.7	29	84.2	17.8	64	147.2	37.2	99	210.2
-20.6	-5	23.0	-1.1	35	95.0	21.1	70	158.0	51.7	125	257.0
-20.0	-4	24.8	-0.6	31	87.8	18.9	66	150.8	40.6	105	221.0
-19.4	-3	26.6	0	32	89.6	19.4	67	152.6	43.3	110	230.0
-18.9	-2	28.4	0.6	33	91.4	20.0	68	154.4	46.1	115	239.0
-18.3	-1	30.2	1.1	34	93.2	20.6	69	156.2	48.9	120	248.0
-17.8	0	32.0	1.7	35	95.0	21.1	70	158.0	51.7	125	257.0
-17.2	1	33.8	2.2	36	96.8	21.7	71	159.8	54.4	130	266.0
-16.7	2	35.6	2.8	37	98.6	22.2	72	161.6	57.2	135	275.0
-16.1	3	37.4	3.3	38	100.4	22.8	73	163.4	60.0	140	284.0
-15.6	4	39.2	3.9	39	102.2	23.3	74	165.2	62.7	145	293.0
-15.0	5	41.0	4.4	40	104.0	23.9	75	167.0	65.6	150	302.0
-14.4	6	42.8	5.0	41	105.8	24.4	76	168.8	68.3	155	311.0
-13.9	7	44.6	5.6	42	107.6	25.0	77	170.6	71.1	160	320.0
-13.3	8	46.4	6.1	43	109.4	25.6	78	172.4	73.9	165	329.0
-12.8	9	48.2	6.7	44	111.2	26.1	79	174.2	76.7	170	338.0
-12.2	10	50.0	7.2	45	113.0	26.7	80	176.0	79.4	172	347.0

6) POWER TRAIN DEVICED

Item		Specification
Torque converter	Type	3 Element, 1 stage, 2 phases
	Stall ratio	5.3 : 1
Transmission	Type	Full auto, power shift
	Gear shift (FR/RR)	2/1
	Adjustment	Electrical single lever type
	Overhaul ratio	FR
RR		1 : 2.494
Axle	Type	Front-wheel drive type, fixed location
	Gear ratio	10.668
	Gear	Ring & pinion gear type
Wheels	Q'ty (FR/RR)	Double : 4/2
	Front (drive)	8.25-15-14 PR
	Rear (steer)	8.25-15-14 PR
Brakes	Travel	Front wheel, wet disc brake
	Parking	Wet disc (negative brake)
Steering	Type	Full hydraulic, power steering
	Steering angle	75.87° to both right and left angle, respectively

SECTION 2 REMOVAL & INSTALLATION OF UNIT

Group 1 Structure	2-1
Group 2 Removal and installation of unit	2-2
Group 3 Maintenance for hose	2-21

(5) Drive axle

※ Before removing the drive axle unit, drain all of the oil from the axle.

- ① Attach a crane to the tilt cylinder notches on the dashboard and raise the truck.
- ② Loosen hexagonal bolts connecting drive axle to drive shaft.
- ③ Put the block under the front axle and support under the drive axle with a truck.

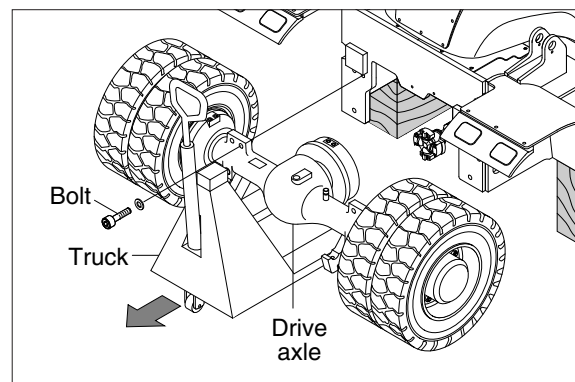
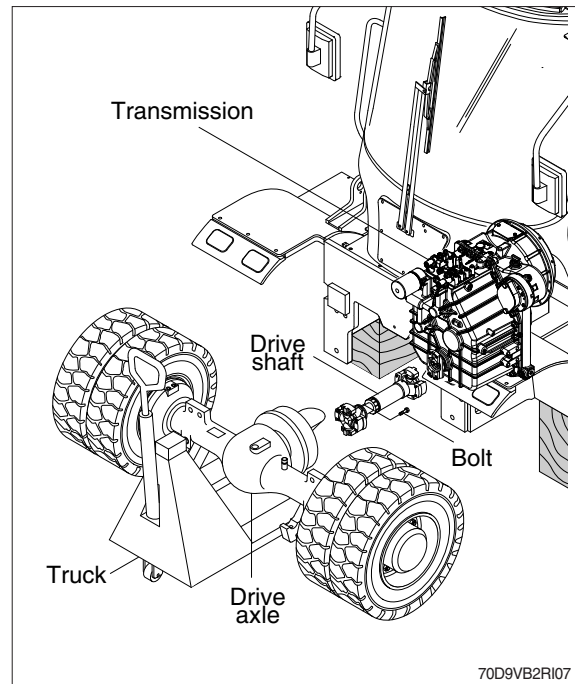

- ⑤ Remove drive shaft from the transmission by loosening the mounting bolts.

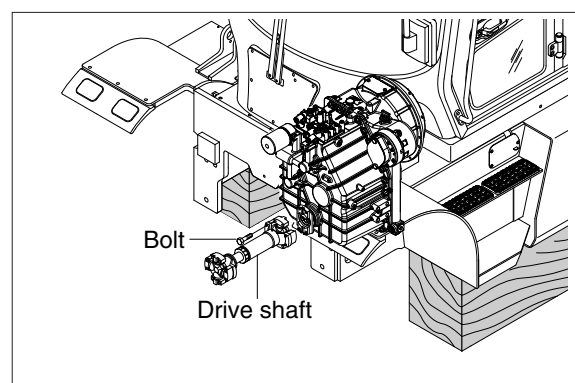

(2) Rear wheel

Remove mounting bolt and hub nut with socket wrench and then carefully take out the tire assembly.

- Tightening torque
 - Hub nut
 61.2 ± 6.1 kgf-m (443 ± 44.1 lbf-ft)
 - Hub cap bolt
 2.5 ± 0.5 kgf-m (18.0 ± 3.6 lbf-ft)

※ Keep gas tight by applying liquid gasket #1215 on the contact surface of the hub cap before assembling the hub cap.

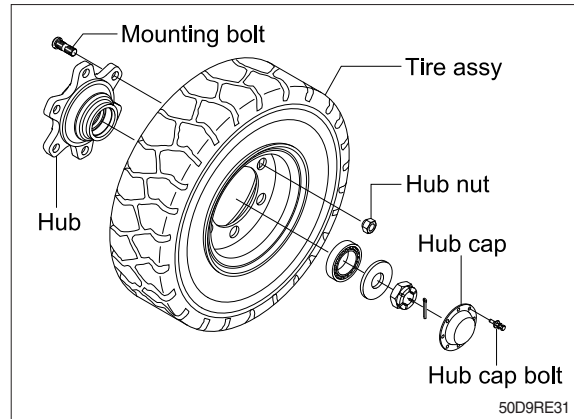

(3) Hose and piping

- ① Disconnect the hoses from the steering axle and then drain out oil.
- ② Disconnect the pipes from the axle support.

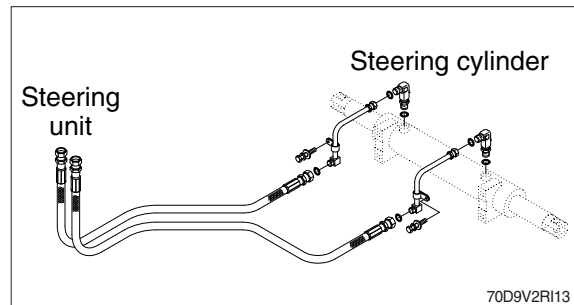

(4) Mounting bolt

Put a block under the steering axle, support on a truck, and raise the frame with a crane. Remove the mounting bolts installing to the frame, and pull out to the rear.

There are shims between the support and steering axle to prevent play.

- Mounting bolt tightening torque
 41.3 ± 6.2 kgf-m (299 ± 44.8 lbf-ft)

※ Apply loctite #277 on the thread before tightening.

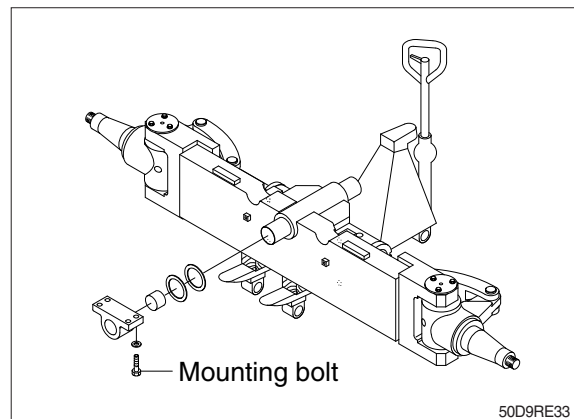

5) CONTROL VALVE

(1) Structure

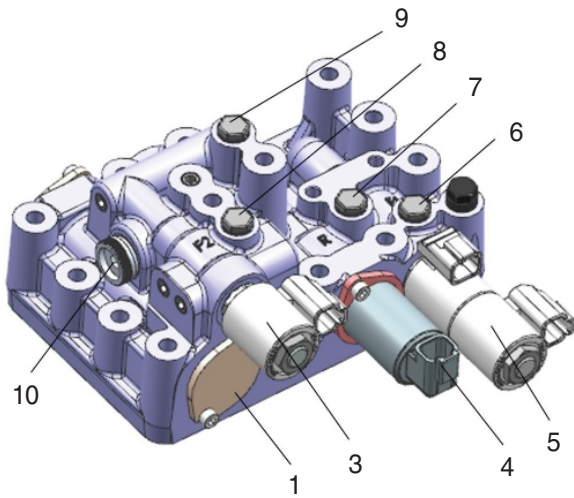

70D9VB3PS06

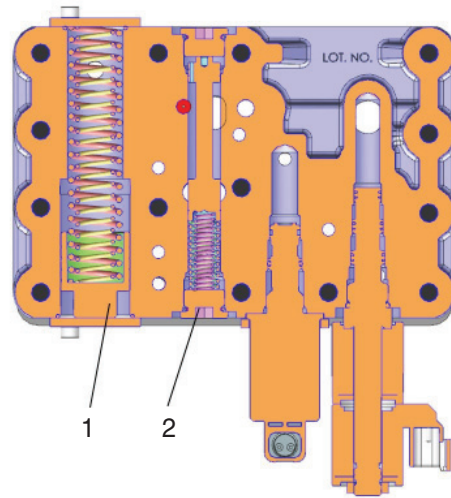

70D9VB3PS07

- | | | | |
|---|----------------------------------|----|--------------------------|
| 1 | Modulation | 6 | Check port for F1 clutch |
| 2 | Main relief | 7 | Check port for R clutch |
| 3 | Solenoid valve for F2 clutch | 8 | Check port for F2 clutch |
| 4 | EPPR valve for inching | 9 | Check port main pressure |
| 5 | Solenoid valve for F1 & R clutch | 10 | Pressure sensor port |

(2) Assembly

Control valve assembly contains main relief valve for regulating pressure of hydraulic clutch assembly, inching valve for adjusting clutch pressure, accumulator valve for rising up clutch pressure smoothly, solenoid valves for selecting direction (F1, F2, R) and controlling parking brake.

Structure	Operation
Main Relief Valve	This valve regulates the clutch pressure stably.
Inching Valve	This valve adjusts the pressure of clutch through the controlling Inching pedal.
Accumulator Valve	This valve adjusts the pressure of clutch for smooth start when the operator wants to move and change the direction.
Solenoid Valve For Dierction (F1, F2, R)	These valve control the oil flow for moving forward 1, 2 & reverse through voltage signal which is given by direction selector.
Solenoid Valve For Parking	This valve control the oil flow for applying and releasing parking brake.

② Loosen the hex bolts and separate the flexible plate

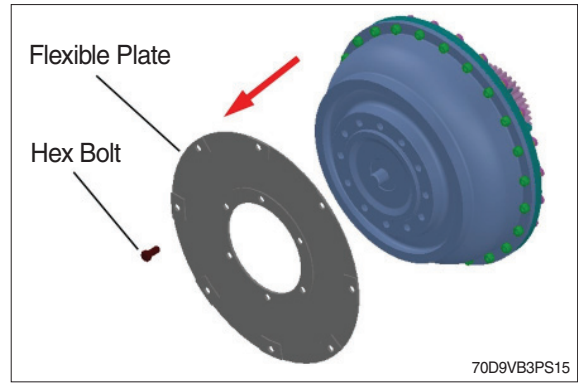

(4) Disassemble PTO shaft.

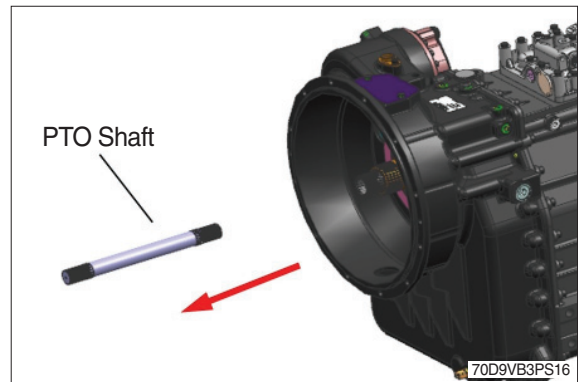

(5) Remove the oil filter and oil filter adaptor.

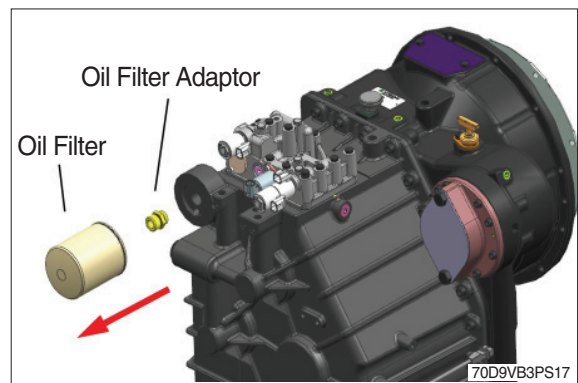

(6) Disassemble the socket bolt and speed sensor.

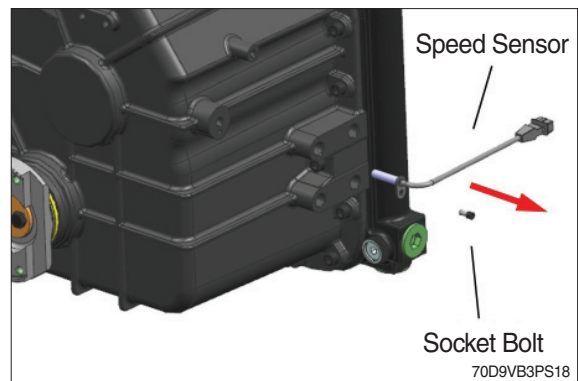

2. ASSEMBLY OF TRANSMISSION

1) SUB ASSEMBLY OF CLUTCH

(1) Assemble the piston groove in the O-ring and glyd ring.

※ Apply T/M oil when assembling the O-ring.

※ How to assemble the glide ring.

- ① Heat the glide ring.
- ② Assemble the gliding when it becomes loose.

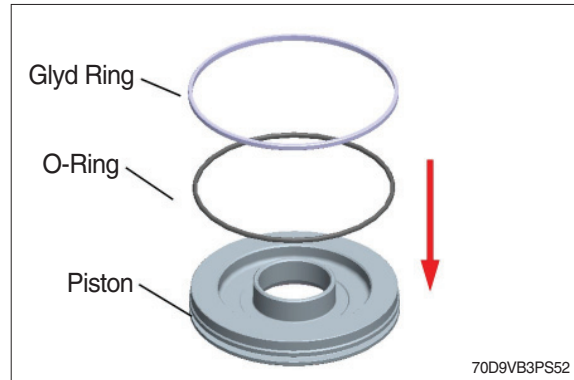

(2) Insert the piston ring into the shaft groove and oil it.

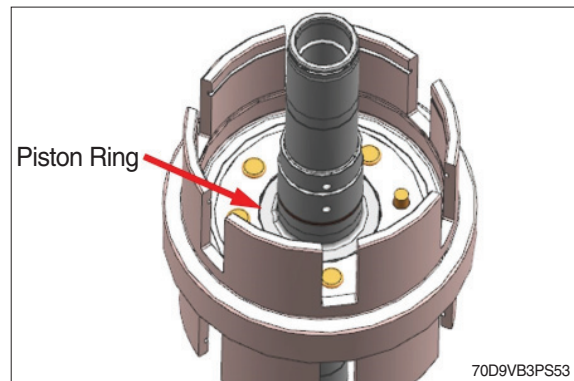

(3) Insert the piston sub into the drum gear.

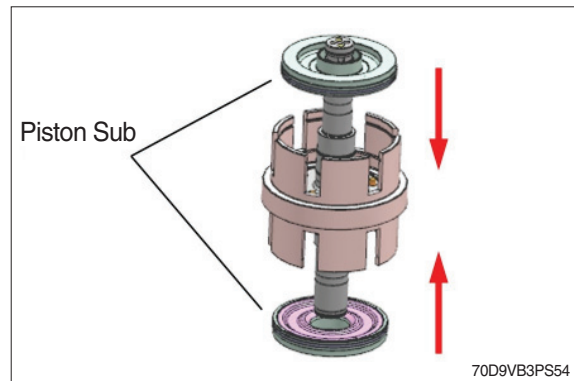

(4) Assemble the spring, spring plate & snap ring.

▲ When removing the snap ring, it may bounce off by spring force, so fix the spring firmly before removing it. Pay attention to safety when removing snap ring.

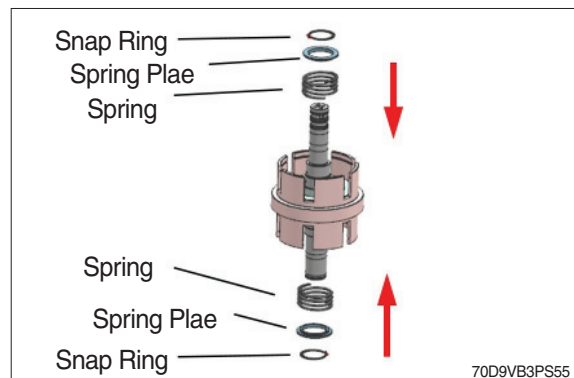

(23) Press in the dowel pins (2 EA).

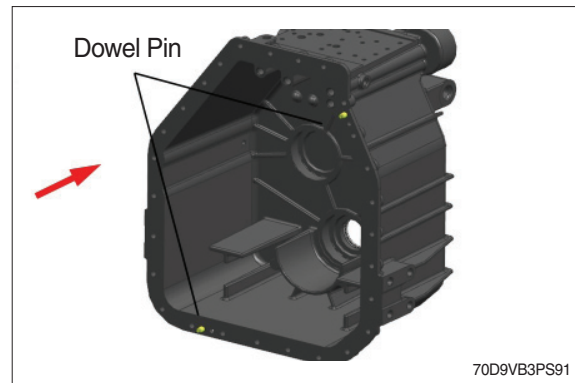

(24) Insert the oil seal into the T/M case.
Spread grease on the seal lip of oil seal.

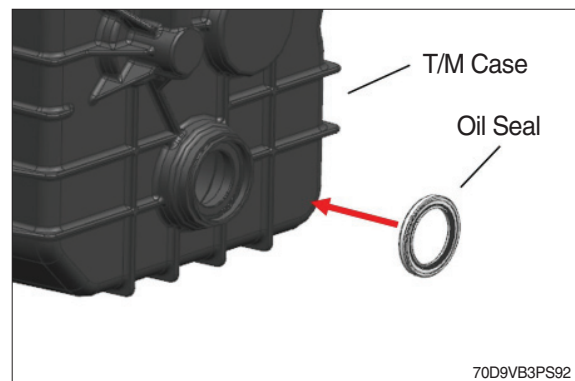

(25) Assemble the T/M case. Tighten the socket bolts.

· Tightening torque : 7.1 ~ 7.7 kgf·m
(51.4 ~ 55.7 lbf·ft)

※ Cover Loctite #5127 on the joint surface of T/M case. Do not apply to the bolt holes.

※ Cover Loctite #277 on socket bolt.

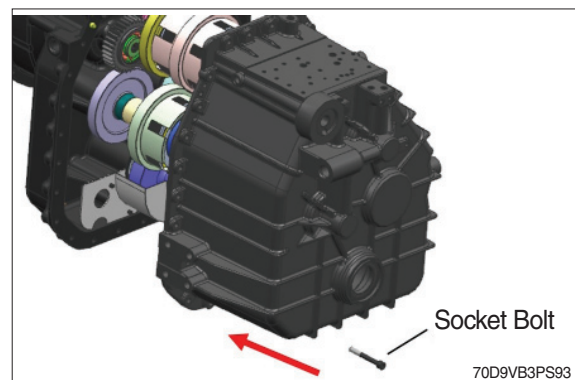

(26) Assemble the spool, spring and tighten the plug.

· Tightening torque : 4.1 ~ 5.1 kgf·m
(29.7 ~ 36.9 lbf·ft)

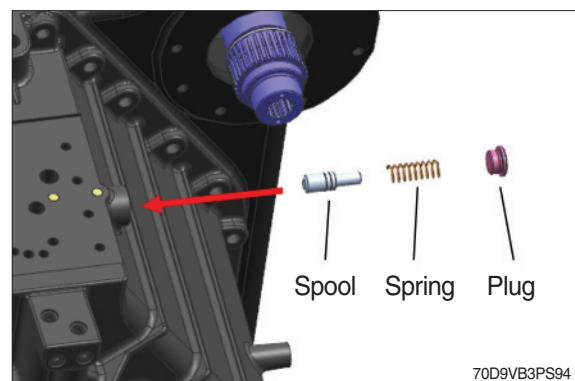

(9) Disassemble oil seal.



(10) Disassemble bearing cone and shim.

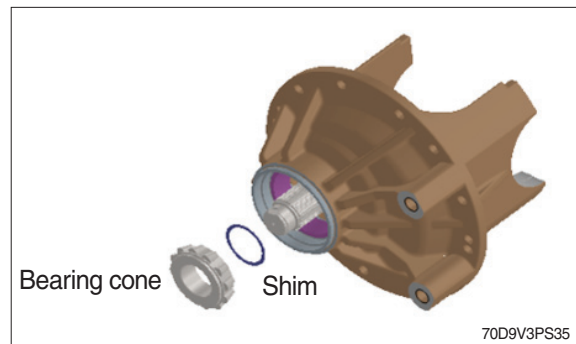

(11) Disassemble pinion shaft.

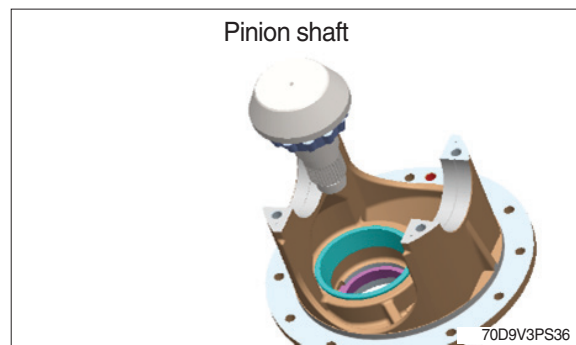

(12) Disassemble oil seal and taper roller bearing.

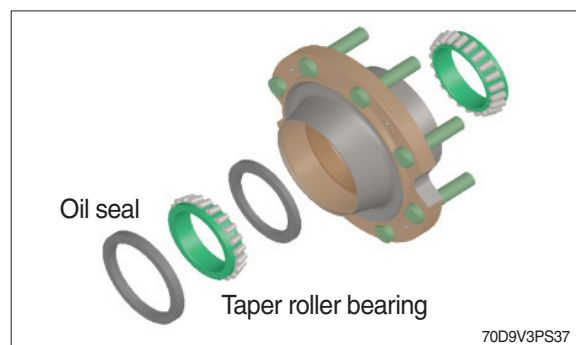

※ The good contact pattern of used gearset is appeared what the length of tooth has had as wear pattern.

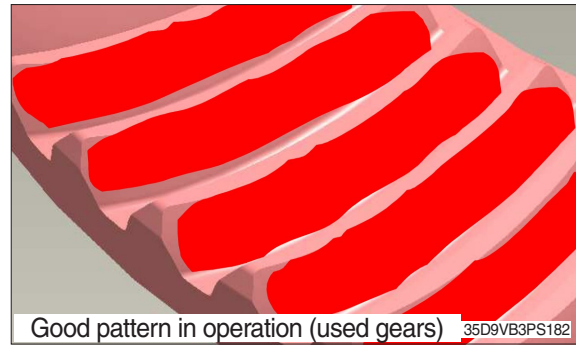

④ If you need control contact pattern to adjust THK of tooth (top/bottom), you should obey steps a-b.

If you need control contact pattern to adjust THK of tooth (toe/heel), you should obey steps c-d.

a. High pattern

If A high contact pattern appear it which pinion was installed shallowly in carrier. To modify, move the pinion toward the ring gear by decreasing the shim pack between pinion spigot and inner bearing cone.

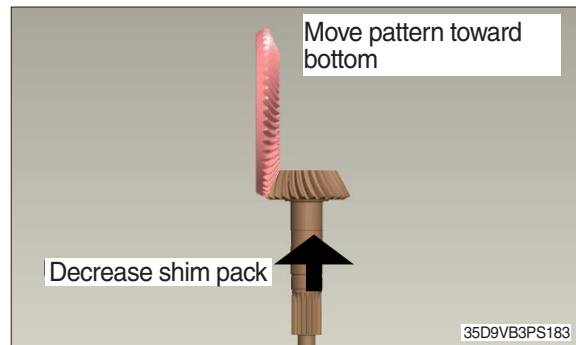

b. Lower pattern

If A low contact pattern appear it which pinion was installed deeply in carrier. To modify, move the pinion away from the ring gear by increasing the shim pack between pinion spigot and inner bearing cone.

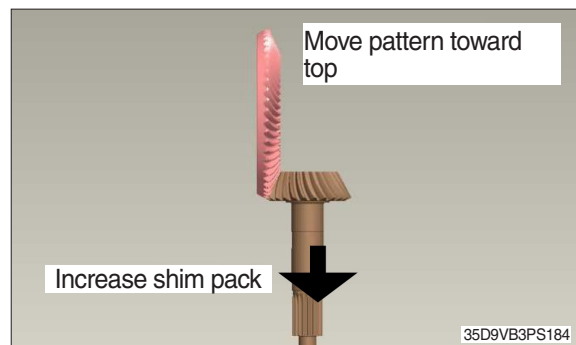

c. Heel pattern

Decrease the gearset backlash (within specified range) to move contact pattern toward toe and away from heel. Refer to "Adjusting the gearset backlash".

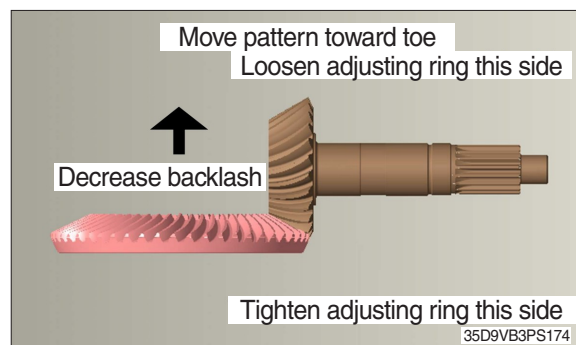

(21) Assemble oil level gauge and air breather on axle housing.

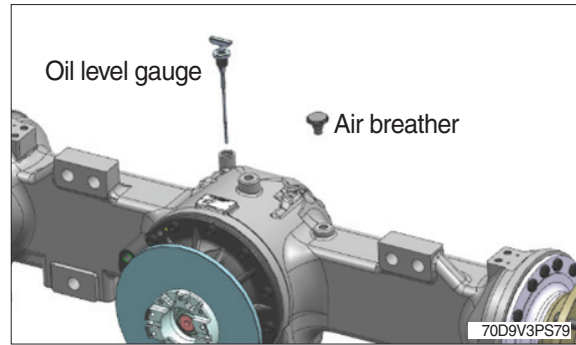

(21) Assemble O-ring, bleeder, and bleeder fitting.

- Tightening torque
 - Bleeder : .4.0 kgf·m (28.9 lbf·ft)
 - Bleeder fitting : 1.8 kgf·m (13.1 lbf·ft)

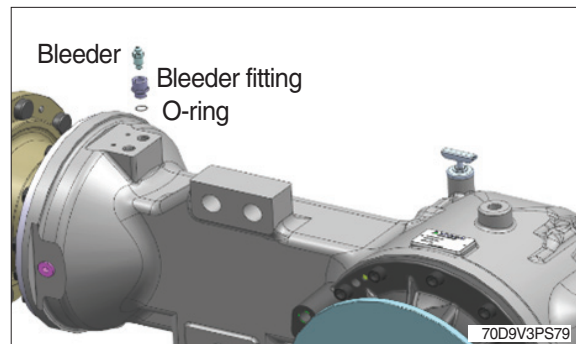

(22) Complete Drive axle assembly

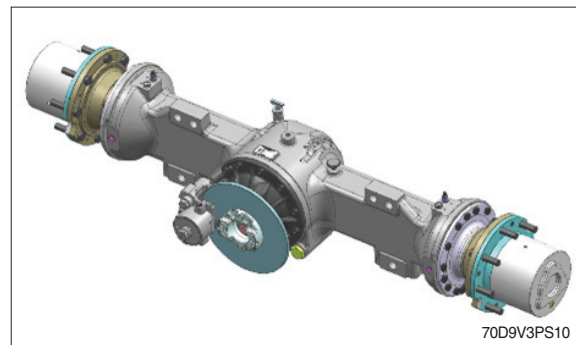

Locating fault and cause		Measures	
Transmission	The clutch is dragging	The clutch plate is sticking.	Please change the clutch plate.
		The clutch piston does not operate normally.	Please repair the clutch piston or change it.
		The pressure of clutch has decreased.	Please check the clutch pressure.
	The bearings are worn or sticking.	Please change the bearings.	

(4) Clutch or converter oil pressure is too high

Locating fault and cause		Measures
Torque converter	Hose of outlet side is bending, and the hose is broken and the oil cooler is clogging.	Please repair or change the hose and oil filter, cooler
	Viscosity of oil is too high. (At cold time)	Please warm up the torque converter if the temperature of torque converter oil is below outside air temperature.
	The oil that is not regulated is used.	Please change the oil to regular oil.
Transmission	Control valve assembly	The valve does not operate normally because spring is broken or spools are stuck in the valve. Please repair the valve assembly or change to new one.

(5) Clutch or converter oil pressure is too low

Locating fault and cause		Measures	
Transmission	The oil is in short supply.	Please replenish oil.	
	The oil that is not regulated is used.	Please change the oil to regular oil.	
	The charging pump is worn and broken.	Please change the charging pump.	
	The oil seal ring or o-ring is worn or damaged.	Please change the oil seal ring or the o-ring.	
	The filter is clogging.	Please wash the oil filter or change it.	
	control valve assembly	The spring is settling, and broken.	Please change the spring.
		The valve does not move with the valve opens.	Please repair the valves or change it.
		The restriction is clogging.	Please wash the restriction.
	Clutch part	The end of the shaft and the seal ring of the clutch piston are damaged.	Please change the clutch piston.

2) SERVICE BRAKE OPERATED

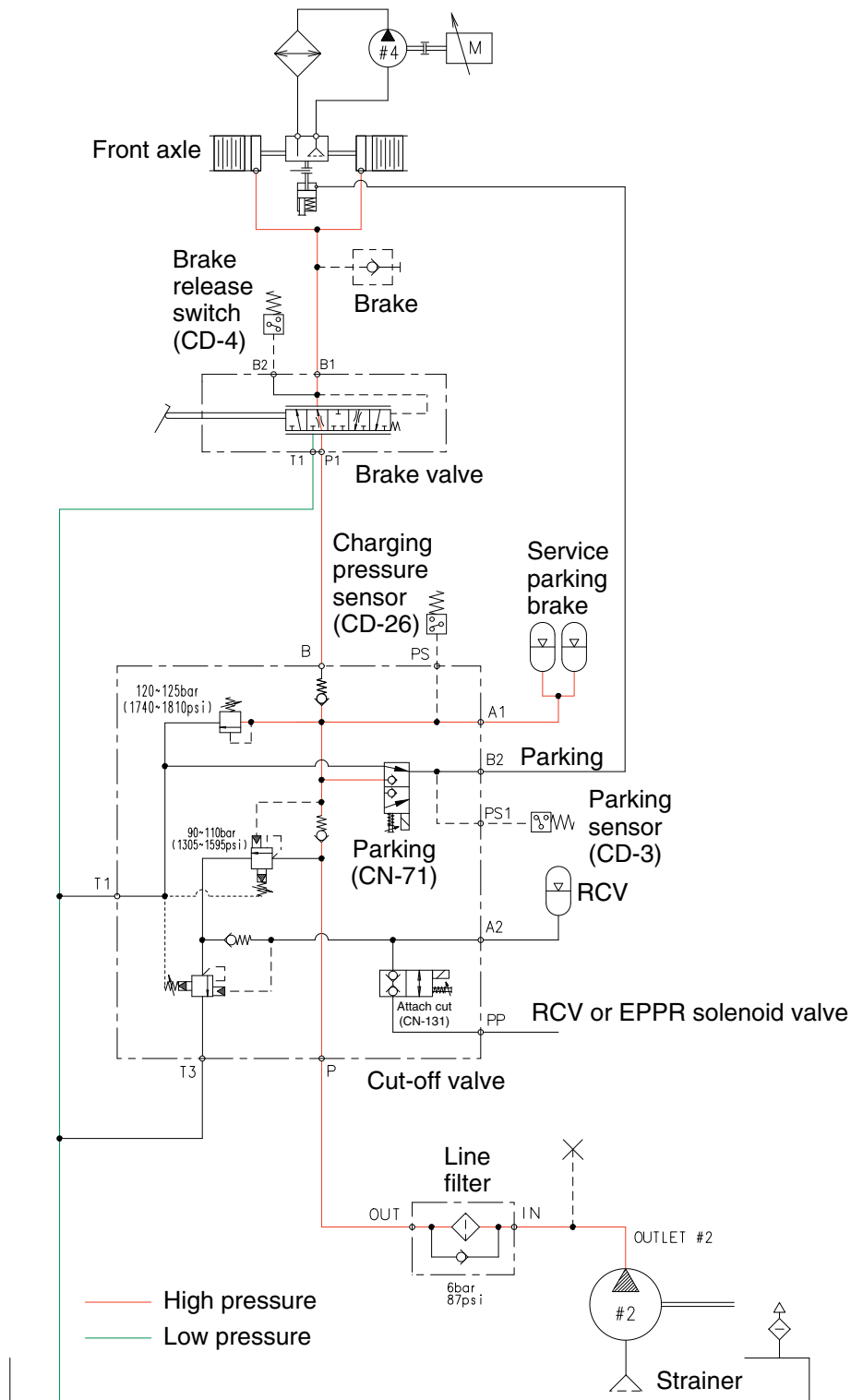

70D9V5BS04

When the pedal of brake valve is depressed, the operating force overcomes the force of the spring, and is transmitted to the spool. When the spool moves down, the inlet port is opened, and at the same time the hydraulic oil controlled the pressure level by the cut-off valve enters the piston in the front and rear axles. Therefore, the service brake is applied.

(5) Disposal of the accumulator

Before the accumulator is scrapped, its gas filling pressure must be reduced. For this purpose, drill a hole through gas chamber (B) using a drill approx. 3 mm in diameter. The gas chamber is located on the side opposite the threaded port above the welding seam around the center of the accumulator.

※ **Wear safety goggles when doing this job.**

(6) Performance testing and checking of the accumulator

The accumulator is gradually pressurized via the test pump; until the initial gas pressure is reached, the hydraulic pressure in the accumulator will rise abruptly. This is apparent from gauge **M**. If the initial gas pressure is more than 30% below the prescribed value, the accumulator needs to be replaced. If the measuring process needs to be repeated, wait for intervals of 3 minutes between the individual tests. Any accumulator whose initial gas pressure is insufficient must be scrapped following the instructions under **Disposal of the accumulator**.

The amount of initial gas pressure can also be checked from the vehicle. Start the vehicle's engine. The pump will now supply oil to the accumulators. Until the initial gas pressure is reached, the hydraulic pressure in the accumulator will rise abruptly. This is apparent from the gauge in the cab. If the initial gas pressure is more than 30% below the prescribed value, that initial pressure lies outside the permissible range for **at least one** of the accumulators fitted in the vehicle. This accumulator can be traced only by using the method described above, i.e. all accumulators have to be individually tested. The accumulator whose initial gas pressure is insufficient must be replaced and scrapped following the instruction under **Disposal of the accumulator**.

(7) Repair work

△ **When working on the braking system, always make sure that there is absolutely no pressure in the system. Even when the engine is switched off there will be some residual pressure in the system.**

※ **When doing repair work, make sure your environment is very clean. Immediately close all open ports on the components and on pipes using plugs.**

△ **For safety reasons the accumulators need to be replaced as a whole if damaged.**

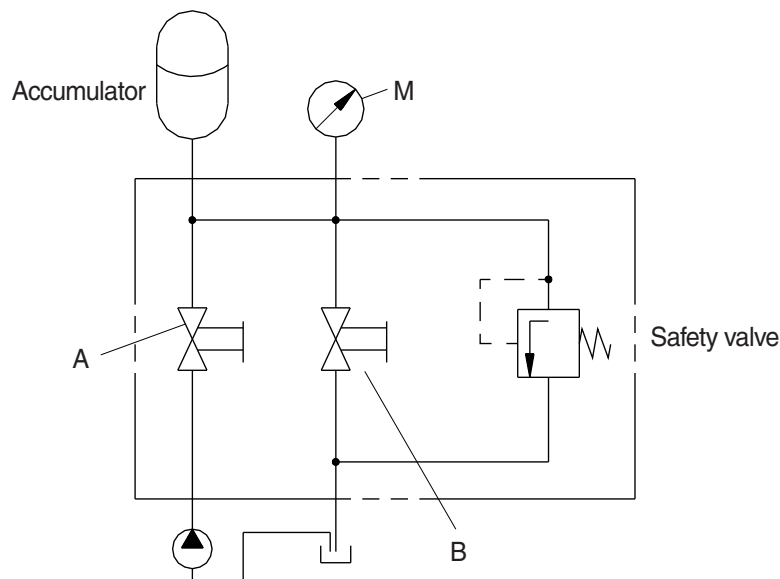

- ③ Tighten plug (3)
- Tool : 19 mm spanner
- Tightening torque : 14.0~16.5 kgf · m

▲ Press-in the DU bushing (11) with a exclusive jig.

▲ Be careful of dust and scrap after washing the parts.

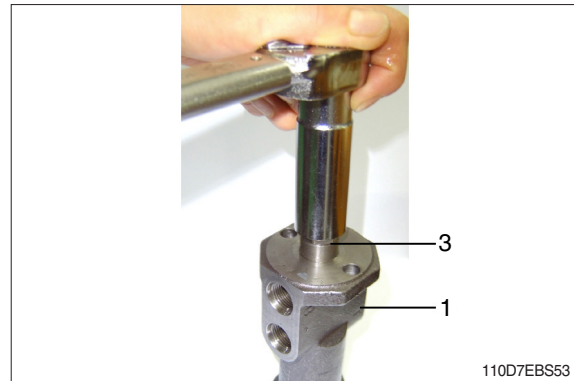

- ④ Spring retainer (7, 27), main spring (6, 28) and holder (4).

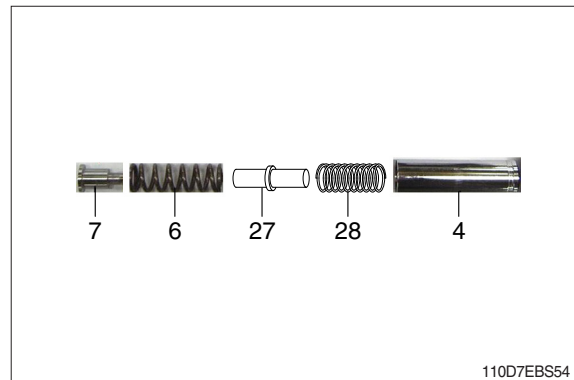

- ⑤ Holder (4) → Body (1)

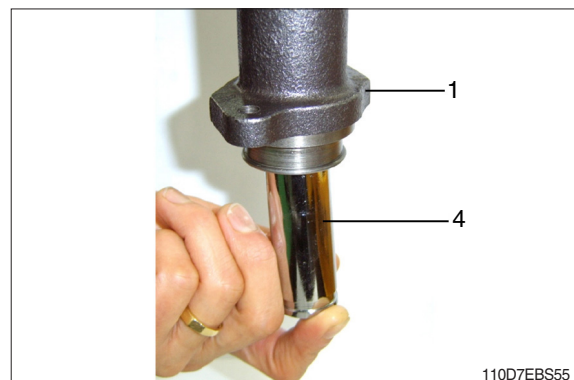

- ⑥ Rubber cover (15)

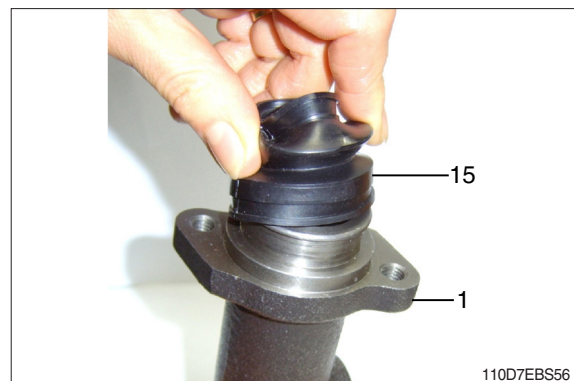

CLICK HERE TO **DOWNLOAD** THE COMPLETE MANUAL

- Thank you very much for reading the preview of the manual.
- You can download the complete manual from: www.heydownloads.com by clicking the link below



- Please note: If there is no response to CLICKING the link, please download this PDF first and then click on it.

CLICK HERE TO **DOWNLOAD** THE COMPLETE MANUAL

4. PRIORITY VALVE

1) STRUCTURE

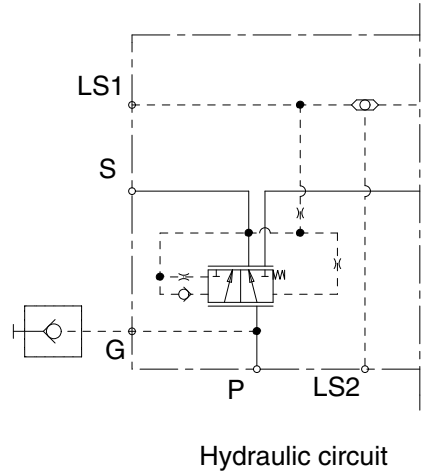
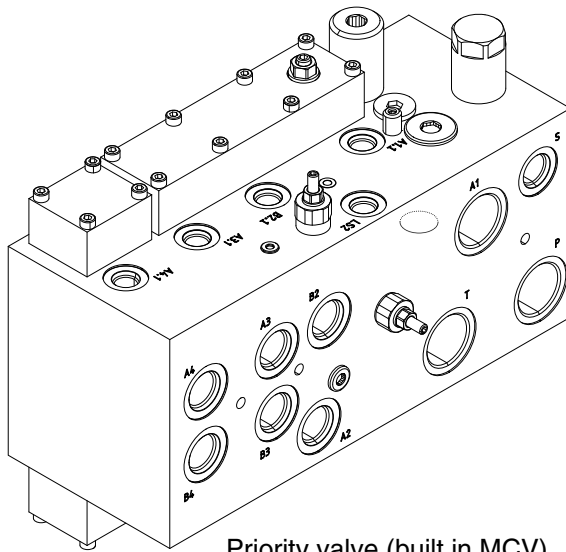

70D9V5SS07

2) STRUCTURE

The oil from the hydraulic pump flows to the priority valve.

The priority valve supplies a flow of oil to the steering system and lift, tilt system.

The steering flow is controlled by the steering unit to operate the steering cylinder.

The remainder of the oil flow from the pump flows to the main control valve.

(9) Remove the distributor plate (16).

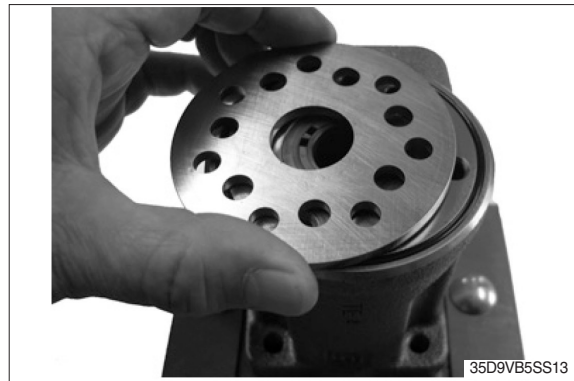

(10) Screw out the ball stop (35) using a 2 mm allen key.

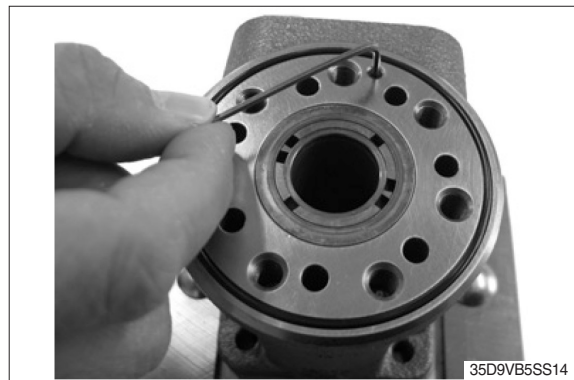

(11) Remove the o-ring (18) from housing.



(12) Remove the check valve (37) using a torx bit size T50.



- (26) Place the 2 o-rings (18) in the two grooves in the gear rim. Fit the gearwheel and rim (17) on the cardan shaft (13).

Place the gear wheel side with all the deeper splines facing downwards. Only this side will fit on the cardan shaft due to all gear sets used in steering unit have timing securing: splines of gear wheel and cardan shaft can only be assembled with correct timing. Line up the gear rim holes to match the thread holes of the housing.

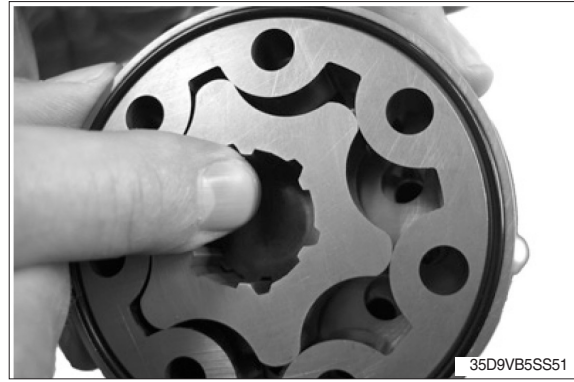

- (27) Place the end cover (19) in position. Ensure that the bar codes and writing are parallel with port face.



- (28) Fit the pin bolt screw (22) with washer (20) and place it in the hole shown.



- (29) Fit the six screws (23) with new washers (20) and insert them. Use a 13 mm top wrench. Cross-tighten all the screws (22 and 23) with a torque

- Tightening torque : 3.1 ± 0.6 kgf·m
(22.4 ± 4.3 lbf·ft)



SECTION 6 HYDRAULIC SYSTEM

Group 1	Structure and function	6-1
Group 2	Operational checks and troubleshooting	6-27
Group 3	Disassembly and assembly	6-32

3) CHECKS AND ADJUSTMENTS

(1) Margin pressure check

The margin pressure is the difference between the pressure at the B-Port and X-Port. If the margin pressure is not within the range shown in the below table, the flow of hydraulic oil out of the variable displacement pump will be either too low or too high.

▲ Do not operate the hydraulic functions while checking the margin pressure. Serious injury to personnel and damage to the lift truck can result if hydraulic functions are operated.

- ① Install pressure gauges on port B and port X respectively. See the illustration for location.
- ② Start the engine and keep the forklift at idle for 5 minutes.
- ③ Check the pressure on the gauge compared to that listed in the under table.
- ④ If the margin pressure is not within the range specified in the below table, go to "The flow compensator adjustment section".

Gague B-X	bar	psi
	25 ± 1	363 ± 14.5

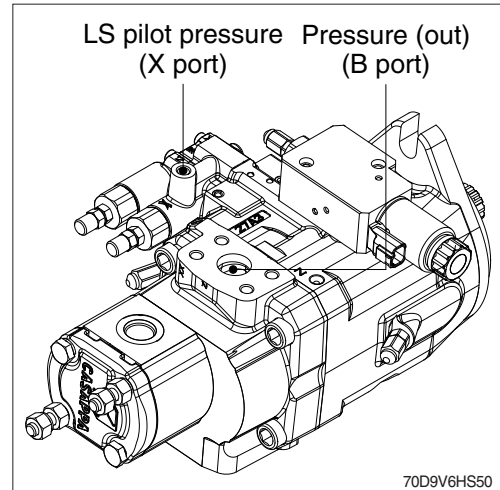

(2) Flow compensator adjustment

- ① Insert an hexagonal wrench (3 mm) into flow compensator adjustment screw. Hold hexagonal wrench in flow compensator screw and turn locknut (13 mm) counterclockwise all the way.
- ② Turn the flow compensator adjustment screw to adjust the B port pressure.
 - Clockwise to increase the B port pressure by 16 bar (232 psi) per turn.
 - Counterclockwise to decrease the B Port pressure by 16 bar (232 psi) per turn.
- ③ Check the margin pressure as described in the margin pressure checks. If margin pressure is not correct, perform Step 1 and Step 2 until correct margin pressure is reached.
- ④ Tighten the locknut to 1.5 kgf-m (10.9 lbf-ft).

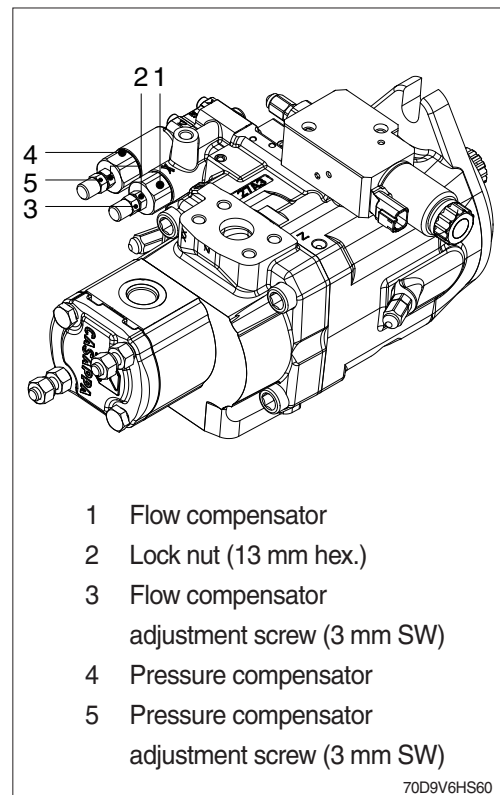

(2) Charging

- ※ The filling kit operation method was prepared based on HYDAC product standards.
- ※ Accumulator gas pressure adjustment and charging kit must be purchased separately.
- ※ To recharge nitrogen gas, it is convenient to use the HYDAC FPU-1 unit.
- ▲ **Must be filled with clean nitrogen gas only. Never use oxygen or air. Explosion hazard. Basically, nitrogen must use a minimum class 4.0. (99,99 %, filtering < 3 μm)**

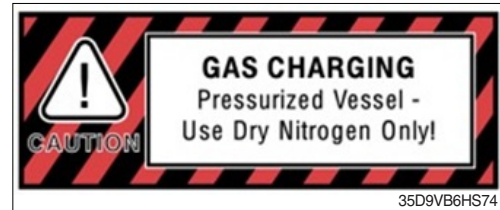

- ① Connect the charging hose to the nitrogen gas cylinder and FPU. Be sure to connect the release valve while it is closed. The release valve has a structure that lengthens when locked and decreases when released.
- ② Loosen the plastic cap and loosen the M8 screw tightly locked to the gas valve connection on the top of the accumulator with a 6 mm hex. wrench and lightly lock it again.
- ③ Connect FPU to the accumulator.
- ④ Using the spindle of FPU, open the M8 screw on the top of the accumulator. (counterclockwise)
- ⑤ Slowly open the valve of the nitrogen gas cylinder and check the pressure of the gas injected into the accumulator.
- ⑥ When filling is complete, close the gas valve of the accumulator using the valve of the nitrogen gas cylinder and the spindle of the FPU.
 - ※ **When adding nitrogen to the accumulator filled with nitrogen gas, wait 5-10 minutes for the temperature and pressure of the gas mixture to stabilize, then check the pressure again and adjust if necessary.**
- ⑦ Open the release valve of FPU to remove nitrogen from the charging hose and FPU.
- ⑧ Using the spindle of FPU, open the accumulator valve, check the gauge, and adjust the release valve to blow out the accumulator nitrogen to the desired pressure.
- ⑨ When the desired pressure is reached, close the release valve of the FPU and close the gas valve of the accumulator using the spindle.

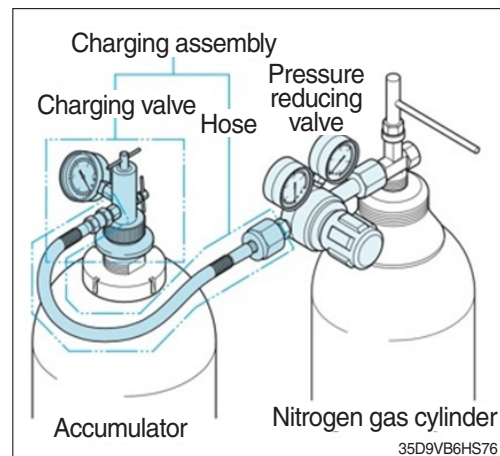
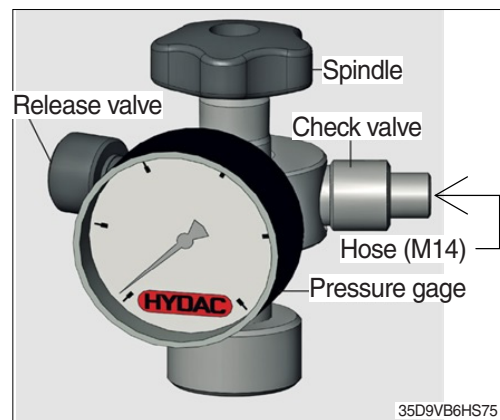

2) MAIN PUMP

Problem	Cause	Remedy
Unusual noises No or insufficient flow	· Insufficient air bleeding of the hydraulic system.	· Fill the axial piston pump, suction line for the hydraulic pump and the oil tank. · Completely air bleed the pump and hydraulic system. · Inspect and correct or replace. - Installation position
	· Insufficient suction conditions - Viscosity of the hydraulic fluid too high - Suction pressure too low - Impermissible filter in the suction line - Foreign particles in the suction line	· Optimize inlet conditions. - Use suitable hydraulic fluid. - Fill the suction line with hydraulic fluid. - Remove foreign particles from the suction line.
	· Improper mounting of the axial piston pump	· Inspect and correct the mounting of the pump. - Observe tightening torques.
	· Improper mounting of assembled parts (hydraulic lines)	· Mount assembled parts according to the information provided.
	· Pump control valve vibration	· Optimize the adjustment of the axial piston pump and the pressure limitation in the hydraulic system.
	· Mechanical damage to the main pump (e.g. bearing damage)	· Inspect and correct or replace.
No or insufficient flow	· Faulty mechanical drive (e.g. defective coupling & spline) · Hydraulic fluid not in optimal viscosity range	· Inspect and correct or replace. · Check temperature range and use suitable hydraulic fluid.
No or insufficient pressure	· Insufficient pilot pressure or control pressure · Output actuator defective (e.g. hydraulic cylinder)	· Check pilot pressure or control pressure. Inspect and correct. · Inspect and correct.
Pressure Flow fluctuations Instabilities	· Malfunction of the control device of the axial piston pump · Wear or mechanical damage to the axial piston pump · Unstable control signal	· Inspect and correct. · Inspect and correct or replace. · Inspect and correct.
Increased, unusual vibration	· Bearings worn	· Inspect and correct or replace.
Excessively high temperature of hydraulic fluid and housing	· Wrong setting or malfunction in the pressure relief and pressure control valves e.g.) - high pressure relief valve - pressure cut-off - pressure controller · Axial piston pump worn	· Optimize the adjustment of the pressure limitation and pressure control valves of the axial piston pump and the pressure safeguarding in the hydraulic system. · Inspect and correct. · Inspect and correct or replace.

(13) Insert the new O-ring seals on the compensator plane.

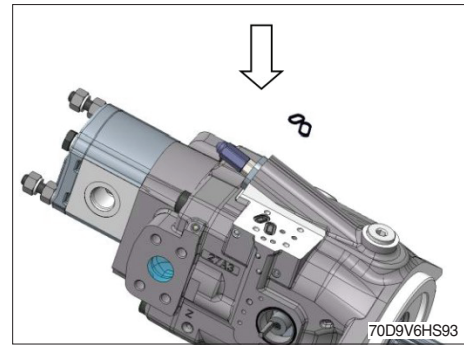

(14) Remove the O-ring seals on DEC (Displacement Electronic Control) plane.

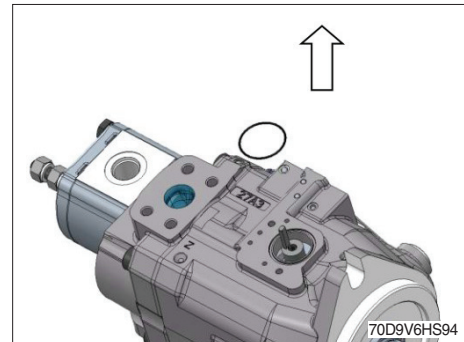

(15) Insert the new O-ring seals on DEC (Displacement Electronic Control) plane.

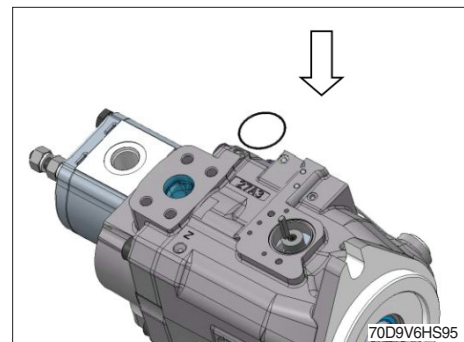

(16) Reassemble the flow and the pressure regulators.

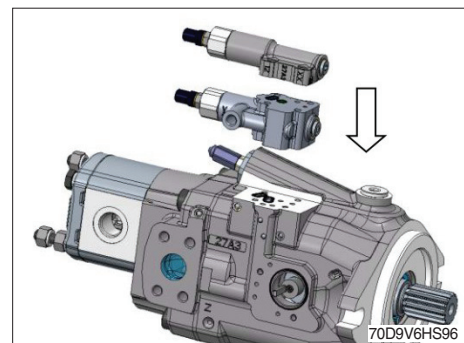

(9) Remove thrust plates and gears from the housing.

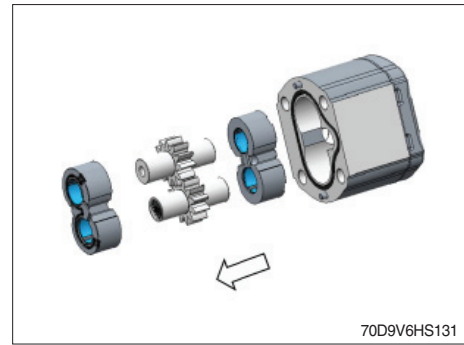

(10) Remove seal and anti-extrusion seal.

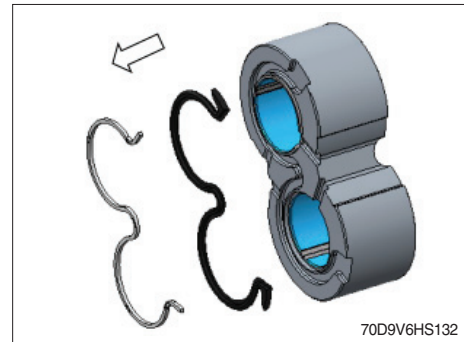

(11) Insert new seal and anti-extrusion seal.

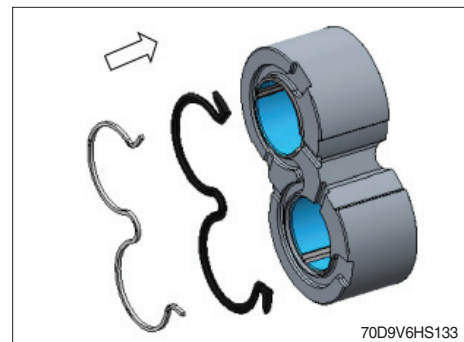

(12) Remove rear cover.

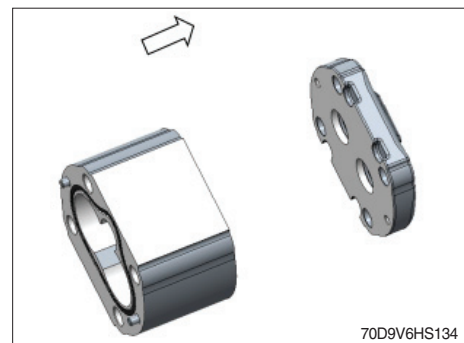

SECTION 7 ELECTRICAL SYSTEM

Group 1 Component location	7-1
Group 2 Electrical circuit	7-3
Group 3 Cluster	7-18
Group 4 Component specification	7-56
Group 5 Connector destination	7-57
Group 6 Troubleshooting	7-60

3. CHARGING CIRCUIT

When the starter is activated and the engine is started, the operator release the start switch to the ON position. Charging current generated by operating alternator flows into the battery.
The current also flows from alternator to each electrical component through the fusible link (CN-95) and the fuse box.

1) OPERATING FLOW

(1) Warning flow

Cluster charging warning lamp (Via CAN interface)

(2) Charging flow

Alternator [CN-74 (B+)] → Start motor [CN-45 (B+)] → Battery (+) charging

2) CHECK POINT

Engine	Key switch	Check point	Voltage
ON	ON	① - GND (Battery voltage) ② - GND (Alternator B+ terminal) ③ - GND (Start motor B+ terminal)	12V

※ GND : Ground

※ Cautions

1. When using an arc welder, always disconnect the ground lead from the battery to prevent alternator or battery damage.
2. Attach the welding ground clamp as close to the weld area as possible to prevent welding current from damaging the bearings of the alternator.
3. Do not disconnect the battery when the engine is running. The voltage surge can damage the diode and resistors in the electrical system.
4. Do not disconnect an electric wire before the engine is stopped and the switches are OFF.

2) GAUGE

(1) Operation screen

Operating screen will be displayed if turn on the start switch.

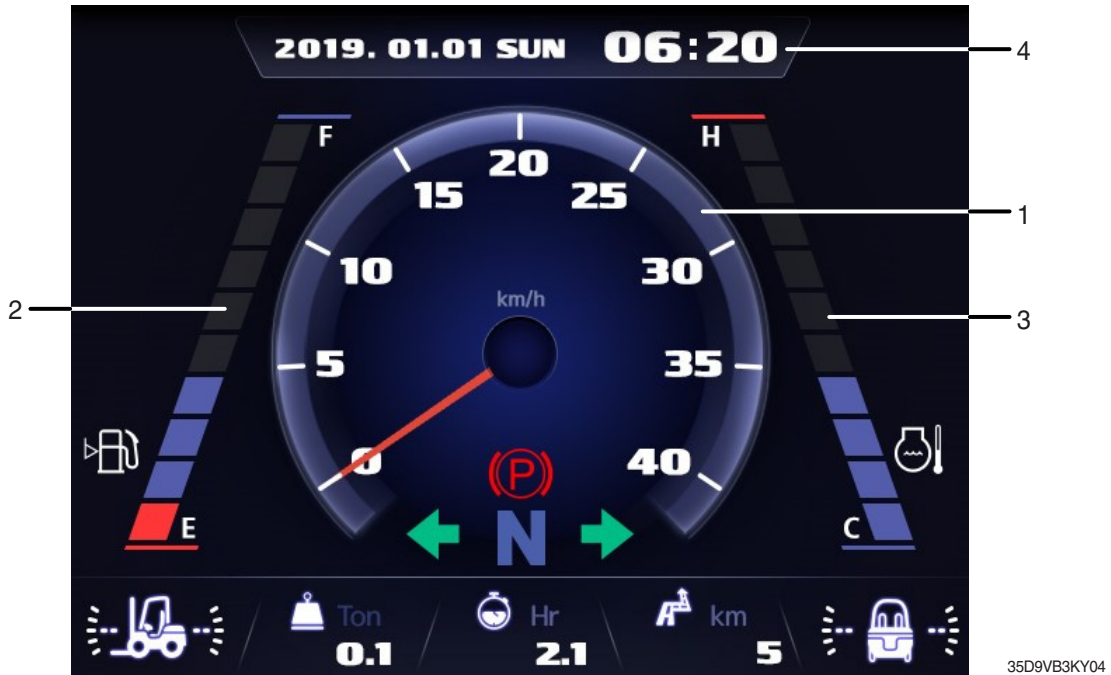

- | | | | |
|---|-------------|---|---------------------------|
| 1 | Speed meter | 3 | Coolant temperature gauge |
| 2 | Fuel gauge | 4 | Clock |

(2) Speed meter

It indicates the speed of truck and calibrated in miles per hour (mph) or kilometer per hour (km/h).

※ Speed unit can be set in the speed unit menu of display set up at page 7-52.

(3) Fuel gauge

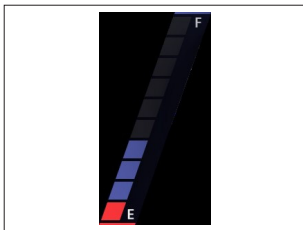

35D9VB3KY05

- Fuel gauge displays the approximate amount of fuel remaining in the fuel tank.
- It shall be obtained fuel as soon as warning lamp  lights on.

(4) Coolant temperature gauge

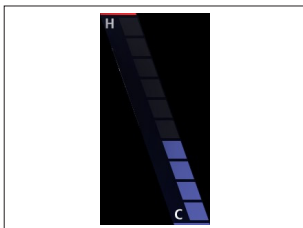

35D9VB3KY06

- It indicates the temperature of the engine coolant.
 - White zone : 40 ~ 120 °C (104 ~ 248 °F)
 - Red zone : Over 120 °C (248 °F)
 - Warning lamp on : Over 115 °C (239 °F)
- If the gauge display in the red zone, or warning lamp  comes on, please stop the engine and inspect the coolant system.

(5) Clock



5) INFORMATION DISPLAY

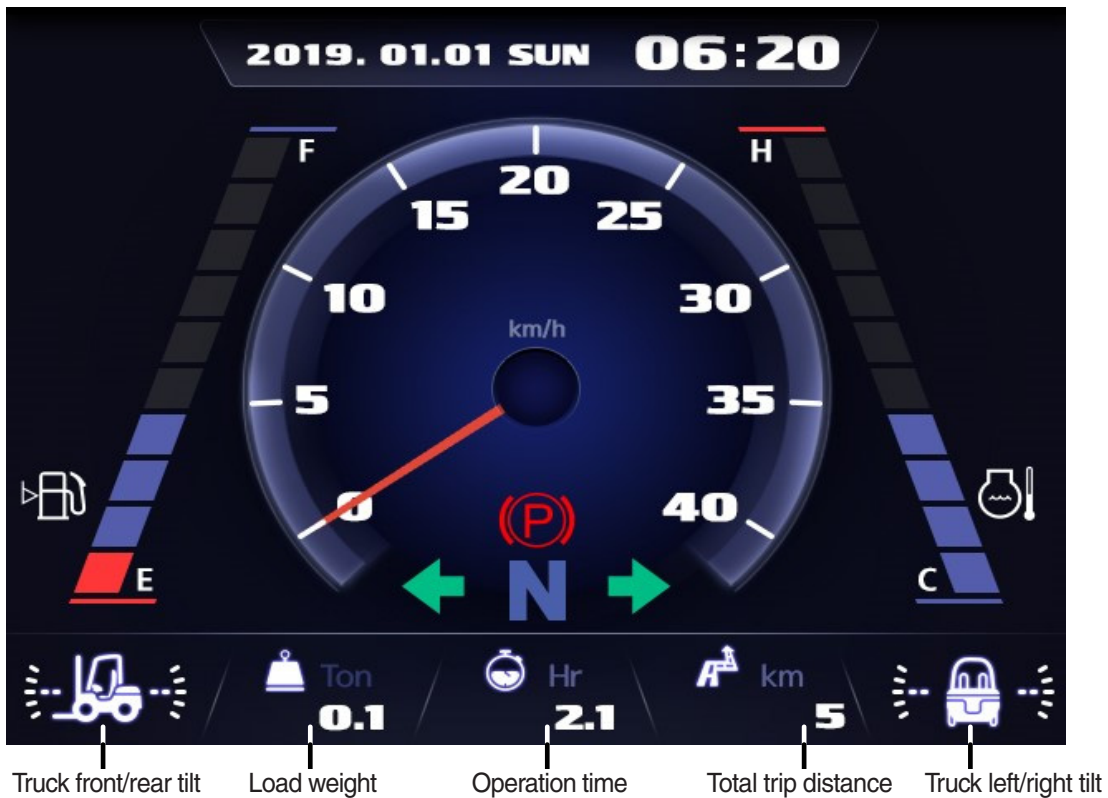

35D9VB3KY35

(1) Mast front/rear tilt



70D9V3KY41

- Display the real time tilt of mast.

(2) Truck front/rear tilt

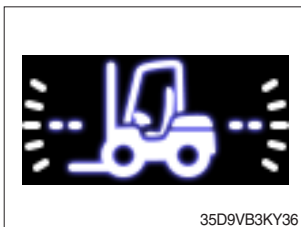

35D9VB3KY36

- Display the front and rear tilt of truck in real time.
- The red warning symbol turned on condition.
 - Stop : Tilt angle is higher than 2.3°
 - Driving : Tilt angle is higher than 10.2°

(3) Truck left/right tilt

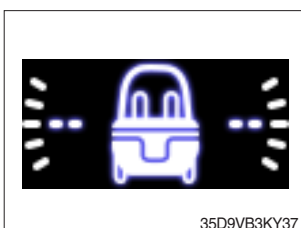

35D9VB3KY37

- Display the left and right tilt of truck in real time.
- The red warning symbol turned on condition.
 - Stop : Tilt angle is higher than 3.4°
 - Driving : Tilt angle is higher than 28.0°

d. Reset

Initialize the all values of 'Unloaded and Loaded Status Adjustment' that were entered previously. (Cylinder cross-sectional area is not initialized.)

3-2. Load Weight Adjustment

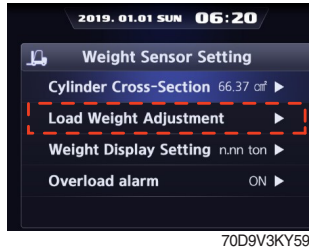

70D9V3KY59

Choose Load Weight Adjustment and enter.

4-3. Reset

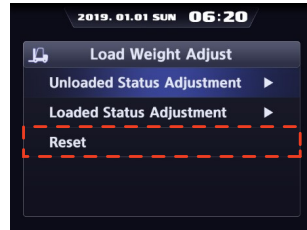

70D9V3KY62

Enter to Reset.

5. Check

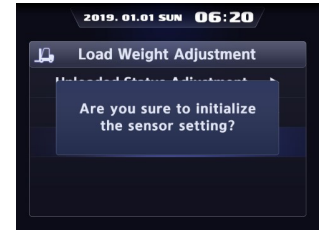

70D9V3KY63

Press the enter button.

6. Completion

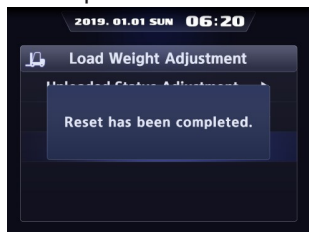

70D9V3KY64

Reset has been completed.

e. Weight Display Setting

Enable to adjust the digit-number fo weight of main screen.

3-3. Weight Display Setting

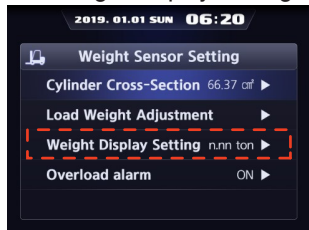

70D9V3KY65

Choose weight sensor setting and enter.

4. Unit



35D9VB3KY81

Choose unit what you want to use.

5. Completion



35D9VB3KY80

Setting has been completed.

· 100 kg unit

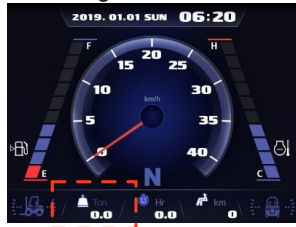

· 10 kg unit

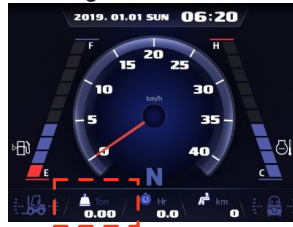

35D9vB3KY83

⑩ Inching Pedal Initialization

1. Equipment

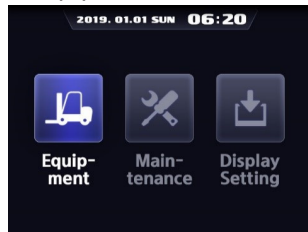

35D9VB3KY47

Enter to Equipment.

2. Inching Pedal Initialization



70D9VB3KY70

Choose Inching Pedal Initialization.

3. Inching Pedal Initialization 2



70D9VB3KY71

Before starting calibration, turn on the parking switch, the gear neutral.

4. Inching Pedal Initialization 3

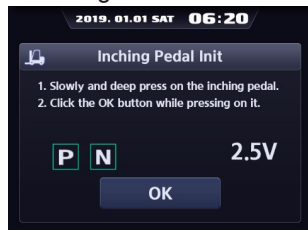

70D9VB3KY72

Fully press the inching pedal.

5. Inching Pedal Initialization 4

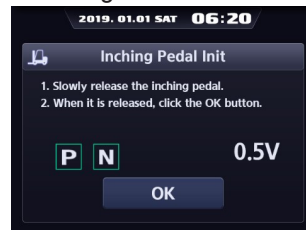

70D9VB3KY73

Take your foot off the inching pedal.

6. Completion



70D9VB3KY74

Confirm the completion of calibration and press the ESC button or OK button to exit to the menu

⑪ Cluster-CI

1. Equipment

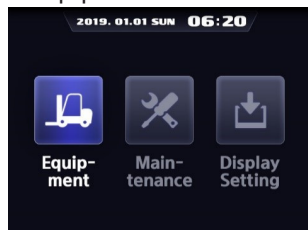

35D9VB3KY47

Enter to Equipment.

2. Version



70D9V3KY136

Choose Version and enter.

3. Cluster-CI



70D9V3KY137

Choose Cluster-CI and enter.

4. Check Version



70D9V3KY138

Connector number	Type	No. of pin	Destination	Connector part No.	
				Female	Male
CN-132	DEUTSCH	2	FWD 2	DT06-2S	-
CN-134	MOLEX	16	Diagnosis	51115-1601	-
CN-136	AMP	4	RMCU service	174257-2	-
CN-139	KET	2	Socket (12 V)	MG610043	-
CN-139	KET	2	Socket (12 V)	MG610043	-
CN-144	AMP	6	Accel pedal	174262-2	-
CN-147	KET	2	Cabin tilt relay switch	MG640188-4	-
CN-151	AMP	36	Engine	-	1743062-2
CN-152	AMP	36	Engine	-	1743062-3
CN-154	KET	1	Engine	MG613801-5	-
CN-155	DEUTSCH	2	Pump EPPR valve	DT06-2S	-
CN-191	AMP	4	G sensor	174257-2	174259-2
CN-202	KET	2	Washer pump top	MG640605	-
CN-249	-	4	Rear view camera	174257-2	174259-2
CN-251	-	1	RMS antenna (ORBCOMM)	FME J1505-58	-
CN-251	-	1	RMS antenna (GPS)	-	FME P1505-316
CN-252	-	1	RMS antenna (ORBCOMM)	TNJ-C-58	TNC-C-58
CN-253	-	1	RMS antenna (GPS)	SMJ-C-316R/V	SMA-C-316R/V
· Switch					
CS-2	KET	2	Start key switch	MG610281	MG620282
CS-5	KET	2	Center horn	-	MG640322
CS-11	KET	8	Multi function switch	MG610339	-
CS-12	KET	6	Multi function switch	MG610335	-
CS-13	AMP	8	Gear selector	174982-2	-
CS-17	CARLING	10	Parking brake switch	21HN-56300	-
CS-21	CARLING	10	Work lamp switch	21HN-56300	-
CS-35	CARLING	10	Rear wiper switch	21HN-56300	-
CS-39	CARLING	10	Main light switch	21HN-56300	-
CS-41	CARLING	10	Hazard switch	21HN-56300	-
CS-42	CARLING	10	Inching switch	21HN-56300	-
CS-59	CARLING	10	Auto shift switch	21HN-56300	-
CS-64	CARLING	10	In/decrement switch	21HN-56300	-
CS-74	DEUTSCH	4	Tilt switch	-	DT04-4P
CS-75	CARLING	10	Regeneration switch	21HN-56300	-
CS-77	CARLING	10	Cabin tilt switch	21HN-56300	-
CS-79	CARLING	10	Power switch	21HN-56300	-
CS-103	CARLING	10	Top wiper/washer switch	21HN-56300	-
· Lamp					
CL-1	-	2	Room lamp (LH)	MG610392	-
CL-3	-	6	Head lamp (LH)	HP285-06021	-

2. TROUBLESHOOTING

1) MAST

Problem	Cause	Remedy
Forks fail to lower.	<ul style="list-style-type: none"> · Deformed mast or carriage. 	<ul style="list-style-type: none"> · Disassemble, repair or replace.
Fork fails to elevate	<ul style="list-style-type: none"> · Faulty hydraulic equipment. · Deformed mast assembly. 	<ul style="list-style-type: none"> · See troubleshooting hydraulic pump and cylinders in section 6, hydraulic system. · Disassemble mast and replace damaged parts or replace complete mast assembly.
Slow lifting speed and insufficient handling capacity.	<ul style="list-style-type: none"> · Faulty hydraulic equipment. · Deformed mast assembly. 	<ul style="list-style-type: none"> · See troubleshooting hydraulic pump and cylinders in section 6, hydraulic system. · Disassemble mast and replace damaged parts or replace complete mast assembly.
Mast fails to lift smoothly.	<ul style="list-style-type: none"> · Deformed masts or carriage. · Faulty hydraulic equipment. · Damaged load and side rollers. · Unequal chain tension between LH & RH sides. · LH & RH mast inclination angles are unequal. (Mast assembly is twisted when tilted) 	<ul style="list-style-type: none"> · Disassembly, repair or replace. · See Troubleshooting Hydraulic Cylinders, pump and control valve in section 6, hydraulic system. · Replace. · Adjust chains. · Adjust tilt cylinder rods.
Abnormal noise is produced when mast is lifted and lowered.	<ul style="list-style-type: none"> · Broken load roller bearings. · Broken side roller bearings. · Deformed masts. · Bent lift cylinder rod. · Deformed carriage. · Broken sheave bearing. 	<ul style="list-style-type: none"> · Replace. · Replace. · Disassemble, repair or replace. · Replace. · Replace. · Replace.
Abnormal noise is produced during tilting operation.	<ul style="list-style-type: none"> · Insufficient lubrication of anchor pin, or worn bushing and pin. · Bent tilt cylinder rod. 	<ul style="list-style-type: none"> · Lubricate or replace. · Replace.

CLICK HERE TO **DOWNLOAD** THE COMPLETE MANUAL

- Thank you very much for reading the preview of the manual.
- You can download the complete manual from: www.heydownloads.com by clicking the link below



- Please note: If there is no response to CLICKING the link, please download this PDF first and then click on it.

CLICK HERE TO **DOWNLOAD** THE COMPLETE MANUAL