

## SECTION 1 GENERAL

Group 1 Safety hints .....	1-1
Group 2 Specifications .....	1-5
Group 3 Periodic replacement .....	1-15

## SECTION 2 REMOVAL & INSTALLATION

Group 1 Major components .....	2-1
Group 2 Removal and installation of unit .....	2-2

## SECTION 3 POWER TRAIN SYSTEM

Group 1 Structure and operation .....	3-1
Group 2 Operation and maintenance .....	3-60
Group 3 Disassembly and assembly .....	3-73
Group 4 Adjustment .....	3-191

## SECTION 4 BRAKE SYSTEM

Group 1 Structure and function .....	4-1
Group 2 Operational checks and troubleshooting .....	4-33
Group 3 Tests and adjustments .....	4-41
Group 4 Disassembly and assembly .....	4-44

## SECTION 5 STEERING SYSTEM

Group 1 Structure and function .....	5-1
Group 2 Operational checks and troubleshooting .....	5-9
Group 3 Tests and adjustments .....	5-17
Group 4 Disassembly and assembly .....	5-21

## SECTION 6 HYDRAULIC SYSTEM

Group 1 Structure and function .....	6-1
Group 2 Operational checks and troubleshooting .....	6-31
Group 3 Disassembly and assembly .....	6-36

## SECTION 7 ELECTRICAL SYSTEM

Group 1 Component location .....	7-1
Group 2 Electrical circuit .....	7-3
Group 3 Cluster .....	7-19

CLICK HERE TO **DOWNLOAD** THE COMPLETE MANUAL

- Thank you very much for reading the preview of the manual.
- You can download the complete manual from: [www.heydownloads.com](http://www.heydownloads.com) by clicking the link below



- Please note: If there is no response to CLICKING the link, please download this PDF first and then click on it.

CLICK HERE TO **DOWNLOAD** THE COMPLETE MANUAL

# SECTION 1 GENERAL

Group 1 Safety hints .....	1-1
Group 2 Specifications .....	1-4
Group 3 Periodic replacement .....	1-15

#### (4) STEERING UNIT

Item	Unit	Specification
Type	-	Load sensing / Non load reaction / Dynamic signal
Capacity	cc/rev	369
Rated flow	lpm	45.4

#### (5) POWER TRAIN DEVICES

Item		Specification		
Torque converter	Model	05 W 340 (ZF SACH)		
	Type	3 Element, 1 stage, 2 phase		
	Stall ratio	2.362 : 1		
Transmission	Type	Full auto, Power shift		
	Gear shift (FR / RR)	3/3		
	Adjustment	Electrical single lever type		
	Overhaul ratio	FR	1 : 5.630	2 : 2.396
RR		1 : 5.647	2 : 2.404	3 : 0.997
Axle	Type	Front-wheel drive type, fixed location		
	Gear ratio	12.7 : 1		
	Gear	Ring & pinion gear type		
Wheels	Q'ty (FR / RR)	Double : 4/2		
	Front (drive)	12.00-20-18PR		
	Rear (steer)	12.00-20-18PR		
Brakes	Travel	Front wheel, Wet disk brake		
	Parking	Axle pinion, caliper brake, hydraulic released		
Steering	Type	Full hydraulic, power steering		
	Steering angle	76° to both right and left angle, respectively		

## GROUP 2 REMOVAL AND INSTALLATION OF UNIT

Remove and install following units as explained in the flow chart.

### 1. MAST

#### 1) REMOVAL

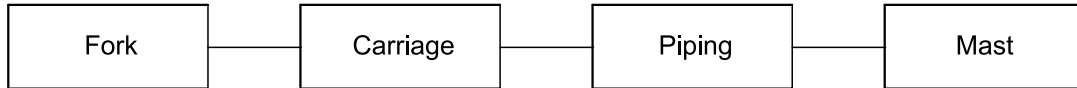

#### (1) Forks

- ① Lower the fork carriage until the forks are approximately 25 mm (1 in) from the floor.
  - ② Release fork retainer and remove cover. Slide one hanger bar at a time out of carriage assembly.
  - ③ Remove only one fork at a time.
- ※ On larger forks it may be necessary to use a block of wood.

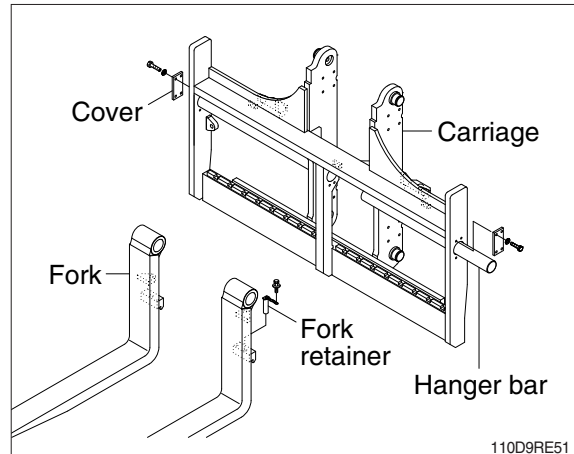

#### (2) Carriage

- ① With the mast vertical, raise the carriage high enough to place blocks under the load forks. This is done to create slack in the load chains when the carriage is lowered. Lower the carriage all the way down to the floor. Make sure the carriage is level, this will prevent any binding when the mast is raised.

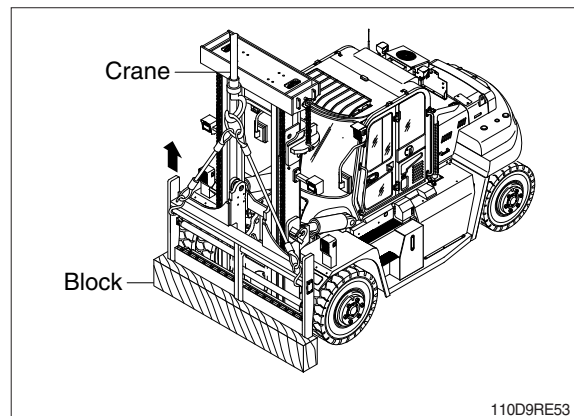

- ② While supporting lift chains, remove nuts from the anchor bolt.

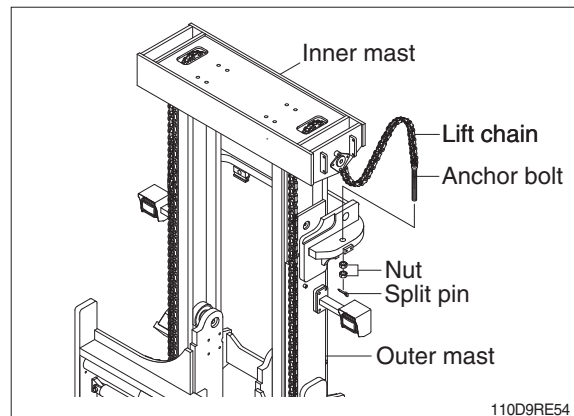

### (8) Flexible plate

- ① Remove the cover on the left side of the flywheel housing then remove the 8 mounting bolts installed to the engine flywheel.

To rotate the flywheel, remove 1 mounting bolt, then insert a turning tool in the mounting hole. One man must turn the engine fan by hand while the other turns the flywheel.

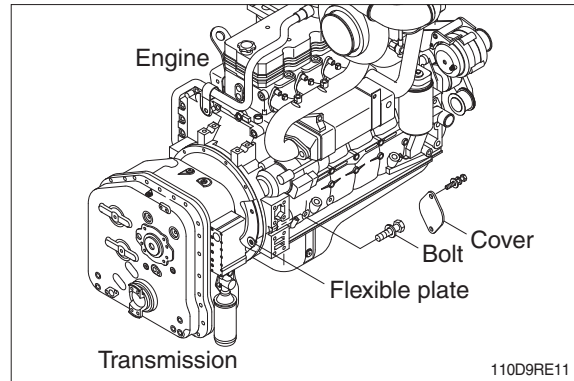

### (9) Mounting bolts holding to flywheel housing

- ① Loosen the mounting bolt 1 to disconnect the transmission assembly from the torque converter housing.
- ② Loosen the socket bolts 2 to disconnect the flexible plate from the engine flywheel.
- ③ Loosen the mounting bolts 3 to disconnect the transmission assembly from the main frame.

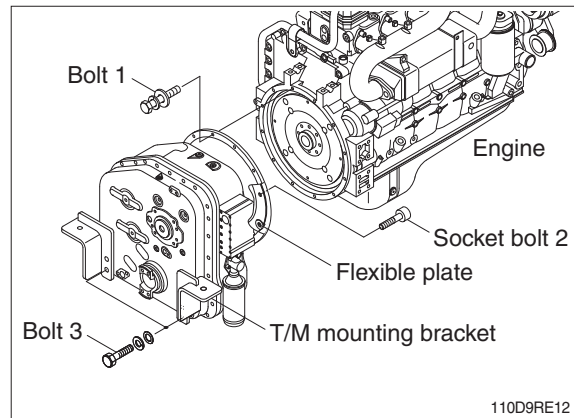

- ④ Using a moving truck slowly pull out transmission assembly to the front.

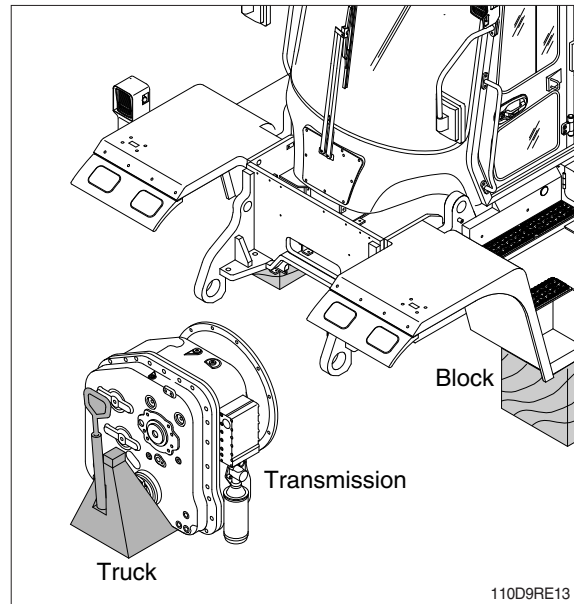

## SECTION 3 POWER TRAIN SYSTEM

Group 1 Structure and operation .....	3-1
Group 2 Operation and maintenance .....	3-60
Group 3 Disassembly and assembly .....	3-73
Group 4 Adjustment .....	3-191

#### 4) ELECTRO-HYDRAULIC SHIFT CONTROL WITH PROPORTIONAL VALVE

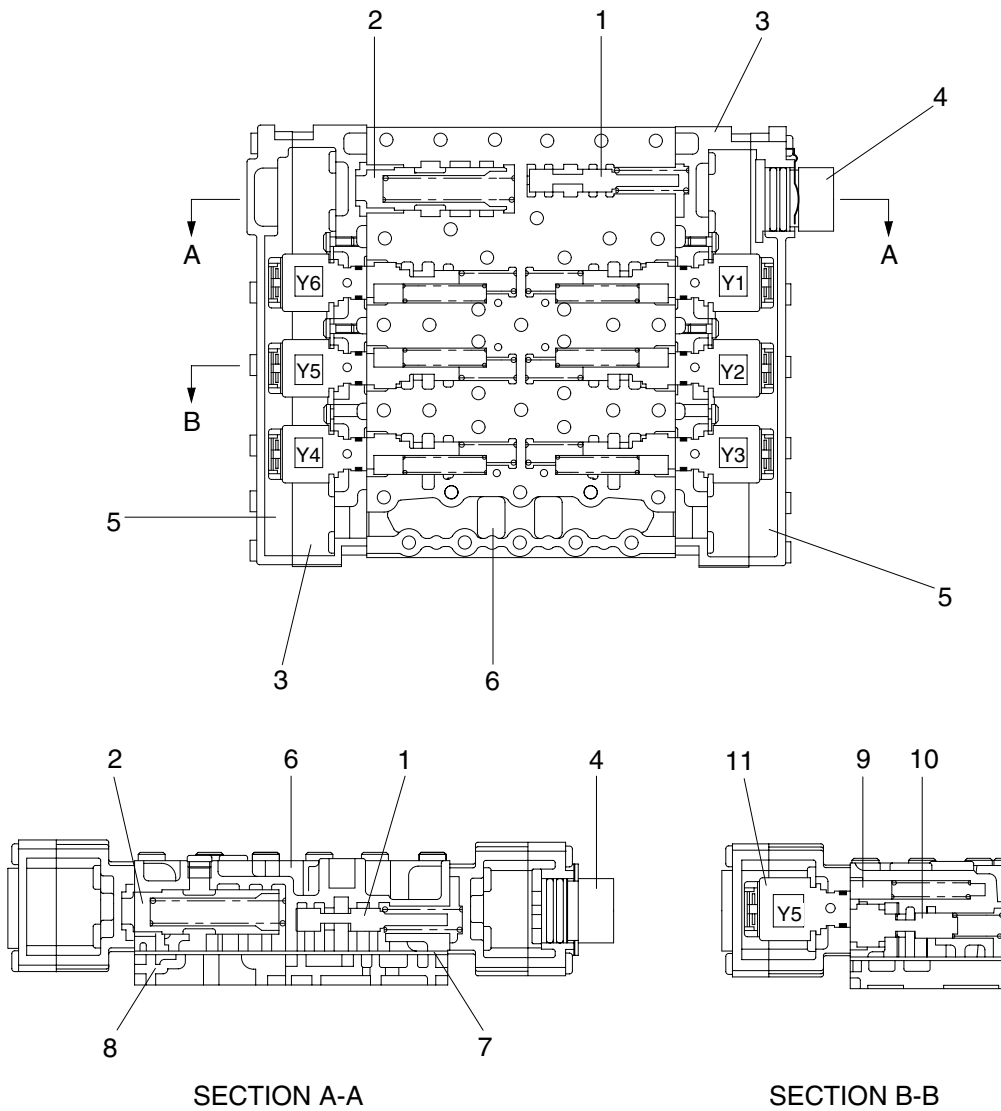

- |   |                                 |    |                    |
|---|---------------------------------|----|--------------------|
| 1 | Pressure reducing valve (9bar)  | 7  | Intermediate plate |
| 2 | Main pressure valve (16 + 2bar) | 8  | Duct plate         |
| 3 | Housing                         | 9  | Vibration damper   |
| 4 | Plug (cable harness)            | 10 | Follow - on slide  |
| 5 | Cover                           | 11 | Pressure regulator |
| 6 | Valve block                     |    |                    |

D507PT03

Fault code (Hex)	Meaning of the fault code possible reason for fault detection	Reaction of the TCU	Possible steps to repair
33	<p><b>Logical error at engine speed input</b> TCU measures a engine speed over a threshold and the next moment the measured speed is zero</p> <ul style="list-style-type: none"> <li>· Cable/connector is defective and has bad contact</li> <li>· Speed sensor has an internal defect</li> <li>· Sensor gap has the wrong size</li> </ul>	OP mode : Substitute clutch control	<ul style="list-style-type: none"> <li>· Check the cable from TCU to the sensor</li> <li>· Check the connectors</li> <li>· Check the speed sensor</li> <li>· Check the sensor gap</li> </ul> <p>※ This fault is reset after power up of TCU</p>
34	<p><b>S.C. to battery voltage or O.C. at turbine speed input</b> TCU measures a voltage higher than 7.00V at speed input pin</p> <ul style="list-style-type: none"> <li>· Cable is defective and is contacted to vehicle battery voltage</li> <li>· Cable has no connection to TCU</li> <li>· Speed sensor has an internal defect</li> <li>· Connector pin is contacted to battery voltage or has no contact</li> </ul>	OP mode : Substitute clutch control If a failure is existing at output speed, TCU shifts to neutral OP mode : Limp home	<ul style="list-style-type: none"> <li>· Check the cable from TCU to the sensor</li> <li>· Check the connectors</li> <li>· Check the speed sensor</li> </ul>
35	<p><b>S.C. to ground at turbine speed input</b> TCU measures a voltage less than 0.45V at speed input pin</p> <ul style="list-style-type: none"> <li>· Cable/connector is defective and is contacted to vehicle ground</li> <li>· Speed sensor has an internal defect</li> </ul>	OP mode : Substitute clutch control If a failure is existing at output speed, TCU shifts to neutral OP mode : Limp home	<ul style="list-style-type: none"> <li>· Check the cable from TCU to the sensor</li> <li>· Check the connectors</li> <li>· Check the speed sensor</li> </ul> <p>※ This fault is reset after power up of TCU</p>
36	<p><b>Logical error at turbine speed input</b> TCU measures a turbine speed over a threshold and at the next moment the measured speed is zero</p> <ul style="list-style-type: none"> <li>· Cable/connector is defective and has bad contact</li> <li>· Speed sensor has an internal defect</li> <li>· Sensor gap has the wrong size</li> </ul>	OP mode : Substitute clutch control If a failure is existing at output speed, TCU shifts to neutral OP mode : Limp home	<ul style="list-style-type: none"> <li>· Check the cable from TCU to the sensor</li> <li>· Check the connectors</li> <li>· Check the speed sensor</li> <li>· Check the sensor gap</li> </ul>
37	<p><b>S.C. to battery voltage or O.C. at internal speed input</b> TCU measures a voltage higher than 7.00V at speed input pin</p> <ul style="list-style-type: none"> <li>· Cable is defective and is contacted to vehicle battery voltage</li> <li>· Cable has no connection to TCU</li> <li>· Speed sensor has an internal defect</li> <li>· Connector pin is contacted to battery voltage or has no contact</li> </ul>	OP mode : Substitute clutch control	<ul style="list-style-type: none"> <li>· Check the cable from TCU to the sensor</li> <li>· Check the connectors</li> <li>· Check the speed sensor</li> </ul>
38	<p><b>S.C. to ground at turbine speed input</b> TCU measures a voltage less than 0.45V at speed input pin</p> <ul style="list-style-type: none"> <li>· Cable/connector is defective and is contacted to vehicle ground</li> <li>· Speed sensor has an internal defect</li> </ul>	OP mode : Substitute clutch control	<ul style="list-style-type: none"> <li>· Check the cable from TCU to the sensor</li> <li>· Check the connectors</li> <li>· Check the speed sensor</li> </ul>

Fault code (Hex)	Meaning of the fault code possible reason for fault detection	Reaction of the TCU	Possible steps to repair
B1	<p><b>Slippage at clutch K1</b> TCU calculates a differential speed at closed clutch K1. If this calculated value is out of range, TCU interprets this as slipping clutch</p> <ul style="list-style-type: none"> <li>• Low pressure at clutch K1</li> <li>• Low main pressure</li> <li>• Wrong signal at internal speed sensor</li> <li>• Wrong signal at output speed sensor</li> <li>• Wrong size of the sensor gap</li> <li>• Clutch is defective</li> </ul>	<p>TCU shifts to neutral OP mode : Limp home If failure at another clutch is pending TCU shifts to neutral OP mode : TCU shutdown</p>	<ul style="list-style-type: none"> <li>• Check pressure at clutch K1</li> <li>• Check main pressure in the system</li> <li>• Check sensor gap at internal speed sensor</li> <li>• Check sensor gap at output speed sensor</li> <li>• Check signal at internal speed sensor</li> <li>• Check signal at output speed sensor</li> <li>• Replace clutch</li> </ul>
B2	<p><b>Slippage at clutch K2</b> TCU calculates a differential speed at closed clutch K2. If this calculated value is out of range, TCU interprets this as slipping clutch</p> <ul style="list-style-type: none"> <li>• Low pressure at clutch K2</li> <li>• Low main pressure</li> <li>• Wrong signal at internal speed sensor</li> <li>• Wrong signal at output speed sensor</li> <li>• Wrong size of the sensor gap</li> <li>• Clutch is defective</li> </ul>	<p>TCU shifts to neutral OP mode : Limp home If failure at another clutch is pending TCU shifts to neutral OP mode : TCU shutdown</p>	<ul style="list-style-type: none"> <li>• Check pressure at clutch K2</li> <li>• Check main pressure in the system</li> <li>• Check sensor gap at internal speed sensor</li> <li>• Check sensor gap at output speed sensor</li> <li>• Check signal at internal speed sensor</li> <li>• Check signal at output speed sensor</li> <li>• Replace clutch</li> </ul>
B3	<p><b>Slippage at clutch K3</b> TCU calculates a differential speed at closed clutch K3. If this calculated value is out of range, TCU interprets this as slipping clutch</p> <ul style="list-style-type: none"> <li>• Low pressure at clutch K3</li> <li>• Low main pressure</li> <li>• Wrong signal at internal speed sensor</li> <li>• Wrong signal at output speed sensor</li> <li>• Wrong size of the sensor gap</li> <li>• Clutch is defective</li> </ul>	<p>TCU shifts to neutral OP mode : Limp home If failure at another clutch is pending TCU shifts to neutral OP mode : TCU shutdown</p>	<ul style="list-style-type: none"> <li>• Check pressure at clutch K3</li> <li>• Check main pressure in the system</li> <li>• Check sensor gap at internal speed sensor</li> <li>• Check sensor gap at output speed sensor</li> <li>• Check signal at internal speed sensor</li> <li>• Check signal at output speed sensor</li> <li>• Replace clutch</li> </ul>

## **(2) Inching device**

This function is especially suitable for lift trucks. It allows to reduce the driving speed infinitely variable without modification of the engine speed in such a way that driving with a very low speed will be possible. In his way, the driver can move the vehicle very exactly to a determined position.

At the same time and important part of the engine power for the output of the hydraulic system is at disposal by the high engine speed.

Operation is carried out by a separate inching pedal, where an angle of rotation sensor is mounted.

By means of the proportional valve technology the TCU regulates the pressure in the driving direction clutch in such a way that the driving speed is adjusted in accordance with the inch rotating angle sensor position. Clutch overloading is avoided thanks to the electronic protection.

## (2) Driving axle tightening torque specifications

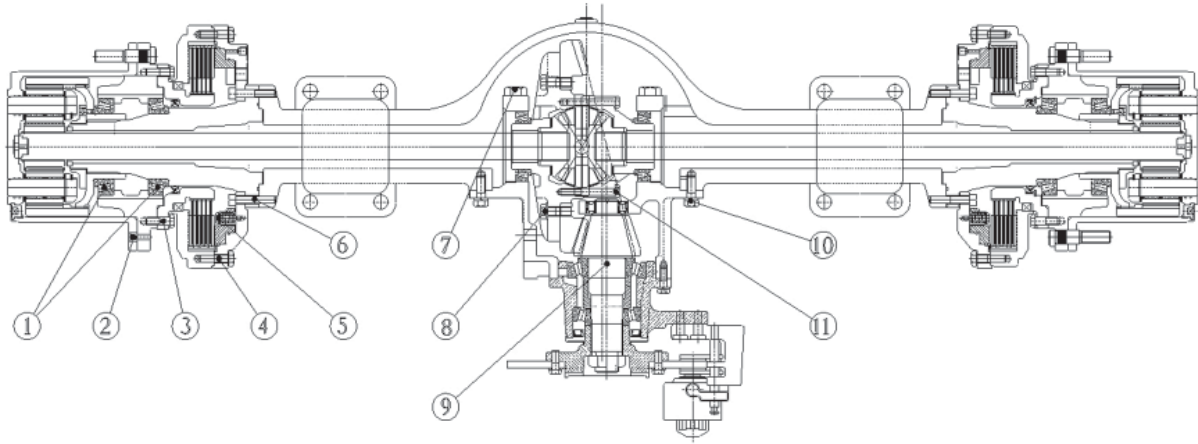

110DEDA04

1	Wheel hub pre-load	330~400kg · cm
2	Plenary housing tightening torque	250~400kg · cm
3	Spline hub tightening torque	3200±50kg · cm
4	Brake cover tightening torque	2100±50kg · cm
5	Self-adjust bolt tightening torque	300~350kg · cm
6	Axle tube tightening torque	3200±50kg · cm
7	Diff carrier cap tightening torque	5500±100kg · cm
8	Ring gear tightening torque	4500±100kg · cm
9	Pinion shaft pre-load tightening torque	Disassembly and assembly reference
10	Diff case tightening torque	2500±50kg · cm
11	Diff carrier assy tightening torque	1000±50kg · cm

## GROUP 2 OPERATION AND MAINTENANCE

### 1. OPERATION

#### 1) DRIVING PREPARATION AND MAINTENANCE

Prior to the commissioning of the transmission, take care that the prescribed oil grade will be filled in with the correct quantity. At the initial filling of the transmission has to be considered that the oil cooler, the pressure filters as well as the pipes must get filled with oil.

According to these cavities, the quantity of oil to be filled in, is greater than at the later oil fillings in the course of the usual maintenance service.

- ※ Because the converter and the oil cooler, installed in the vehicle, as well as the pipes can empty at standstill into the transmission, the **oil level check must be carried out at engine idling speed and operation temperature of the transmission.**

**▲ At the oil level check, the vehicle has to be secured against rolling by blocks, articulated vehicles additionally against unintended turning-in.**

#### 2) DRIVING AND SHIFTING

##### (1) Neutral position

Neutral position will be selected via the gear selector.

After the ignition is switched on, the electronics remains in the waiting state. By the position NEUTRAL of the gear selector, the TCU becomes ready for operation.

A gear can be engaged.

##### (2) Starting

The starting of the engine has always to be carried out in the NEUTRAL POSITION of the gear selector.

For safety reasons it is to recommend to brake the vehicle securely in position with the parking brake prior to start the engine.

After the starting of the engine and the preselection of the driving direction and the gear, the vehicle can be set in motion by acceleration.

At the start off, the converter takes over the function of a master clutch.

On a level road it is possible to start off also in higher gears.

##### - Upshifting under load.

Upshifting under load will be then realized if the vehicle can continue to accelerate by it.

##### - Downshifting under load.

Downshifting under load will be then realized if more traction force is needed.

## 5) BRAKE DOES NOT RELEASE

Condition	Possible cause	Correction
Vehicle does not move	Damaged hydraulic system.	Repair hydraulic system.
Brakes dragging	<ol style="list-style-type: none"> <li>1. More than 1.4bar (20 psi) pressure applied when brakes released.</li> <li>2. Damaged piston return spring assembly.</li> <li>3. Piston not returning.</li> <li>4. Wrong cooling and/or actuation fluid used.</li> <li>5. Parking brake not adjusted properly.</li> </ol>	<ol style="list-style-type: none"> <li>1. Repair hydraulic system so pressure is less than 1.4 bar (20 psi) when brakes released and while machine is operating in any mode.</li> <li>2. Repair or replace piston return spring assembly.</li> <li>3. Check piston seals for swelling or damage. Replace as necessary.</li> <li>4. Check piston seals for swelling or damage. Purge system and use specified fluid.</li> <li>5. Adjust parking brake lever as described in assembly of this manual.</li> </ol>

## 6) BRAKING PERFORMANCE

Condition	Possible cause	Correction
Noticeable change or decrease in stopping performance.	<ol style="list-style-type: none"> <li>1. Inadequate actuation fluid supply to brakes.</li> <li>2. Inadequate pressure to apply brakes.</li> <li>3. Worn or damaged discs.</li> <li>4. Overheated seals and/or discs.</li> <li>5. Dirty or contaminated cooling fluid.</li> </ol>	<ol style="list-style-type: none"> <li>1. Replenish fluid in brake system. Check for leakage and correct cause.</li> <li>2. Check brakes apply system. Check for leakage in brake system or brakes, and correct cause.</li> <li>3. Inspect and replace discs if necessary. ※ As disc wear occurs, make sure brake system can supply adequate fluid to fully apply brakes.</li> <li>4. Inspect and replace discs and seals if necessary.</li> <li>5. Drain and flush cooling fluid from brakes and entire brake system. Replace with approved fluid. In some cases, it may necessary to replace discs. Clean or replace filter.</li> </ol>
Brake does not fully apply.	<ol style="list-style-type: none"> <li>1. Empty fluid reservoir.</li> <li>2. Damaged hydraulic system.</li> <li>3. Leakage of brake actuation fluid.</li> </ol>	<ol style="list-style-type: none"> <li>1. Fill reservoir to correct level with specified fluid.</li> <li>2. Repair hydraulic system.</li> <li>3. Refer to "Brake leaks actuation fluid" in this section.</li> </ol>
Brakes fell spongy/soft.	Brakes or brake system not properly bled.	Bleed brakes and brake system.

- ⑦ Remove the tab washer (2) and loosen the hexagon screws (1).

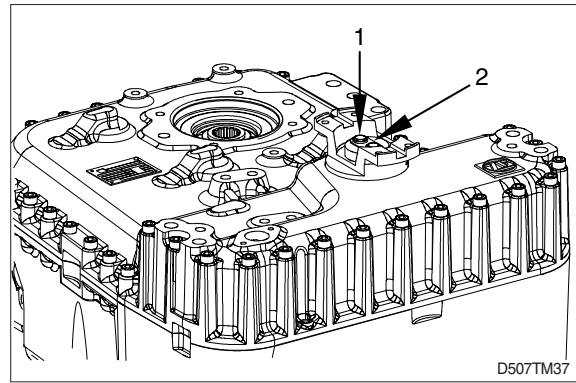

- ⑧ Pull off the input shaft (1).

Remove the shaft seal.

(S) Two-armed puller 5870 970 003

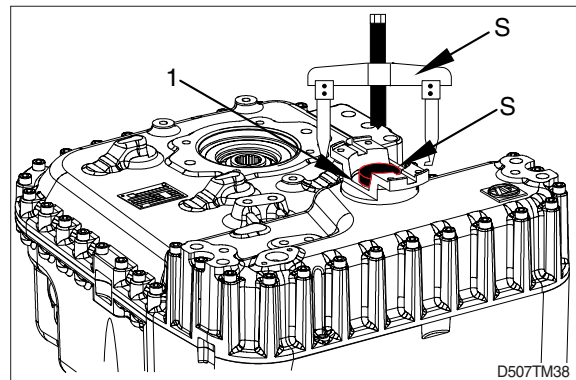

- ⑨ Unsnap the retaining ring (1) from the power take-off and remove the O-ring (2).

(S) Set of internal pliers 5870 900 013

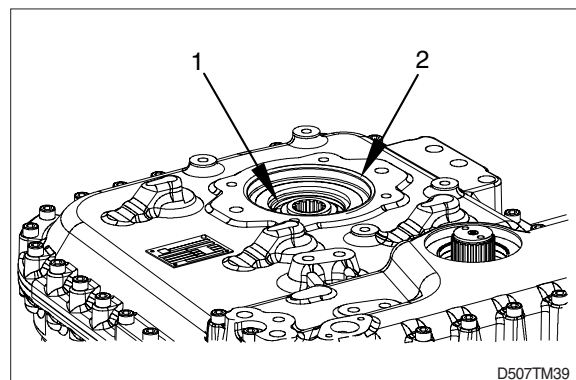

- ⑩ Pull the pump shaft (1) out of the housing bore.

Unsnap the rectangular ring (2).

Press off the ball bearing (3) from the shaft.

Loosen the bolted connection (4) transmission housing rear section/transmission housing front section.

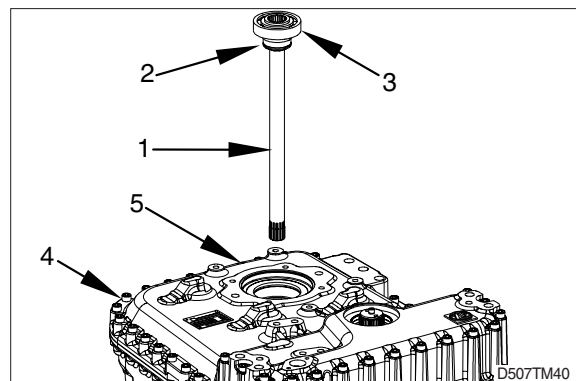

⑧ Pull the taper roller bearing (inner ring) from the shaft.

(S) Gripping insert 5873 001 057

(S) Back-off insert 5870 026 100

or

(S) Rapid grip 5873 011 011

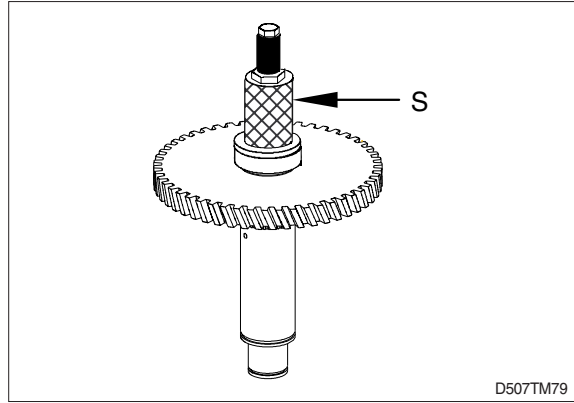

#### (4) Clutch K1

① Remove the stud (1) and unsnap the piston ring (2).

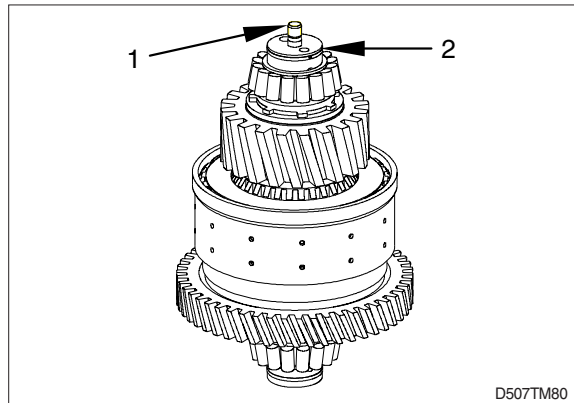

② Pull the taper roller bearing (inner ring) from the shaft.

(S) Gripping insert 5873 001 057

(S) Back-off insert 5870 026 100

or

(S) Rapid grip 5873 011 011

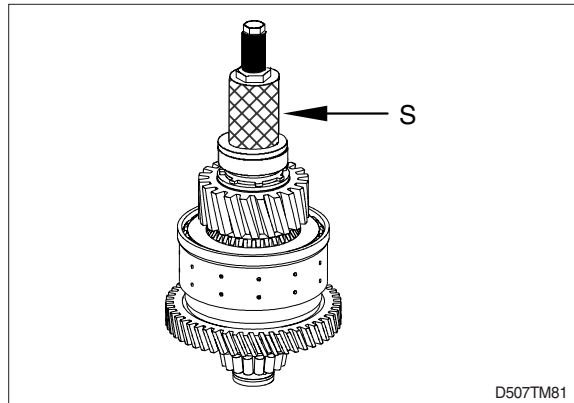

③ Unsnap the retaining ring (1).

(S) Set of internal pliers 5870 900 015

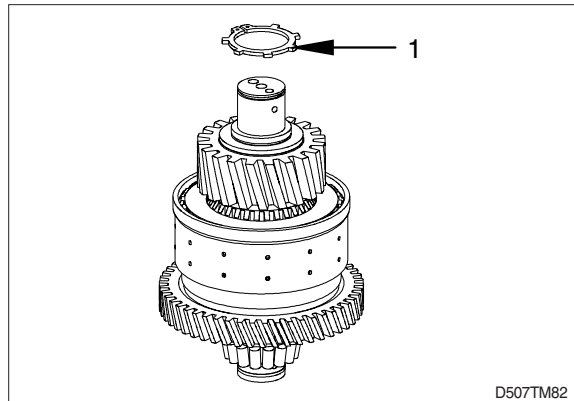

- ⑨ Fasten the idler (1) by means of retaining ring (2).

(S) Set of internal pliers 5870 900 015

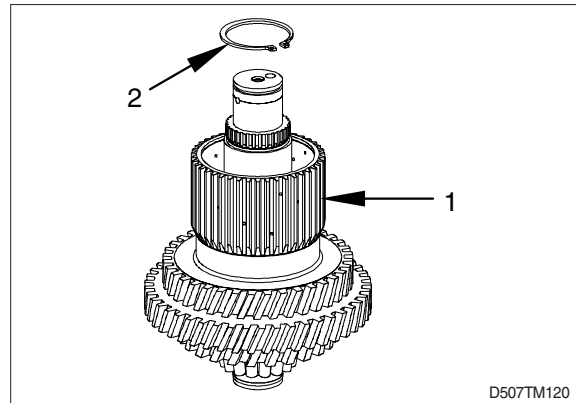

D507TM120

- ⑩ Heat up the inner diameter of the clutch (1) (approx. 120°C).

(S) Hot- air blower 220V 5870 221 500

(S) Hot- air blower 110V 5870 221 501

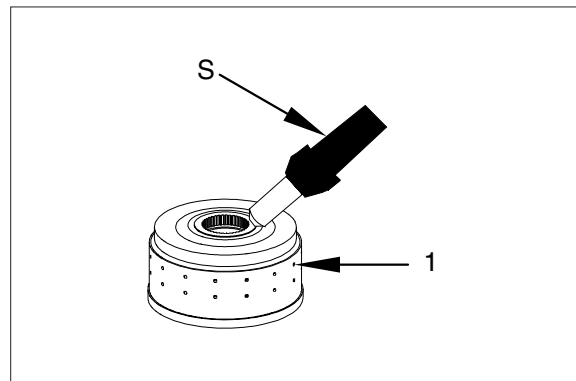

- ⑪ Mount the clutch (1) and press it until contact is obtained.

**▲ Wear safety gloves.**

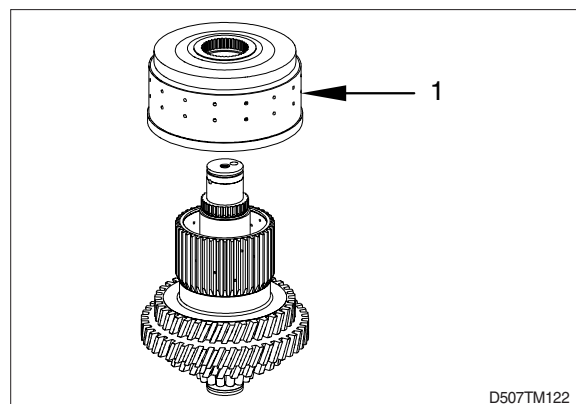

D507TM122

- ⑫ Press the taper roller bearing (inner ring) (1) until contact is obtained.

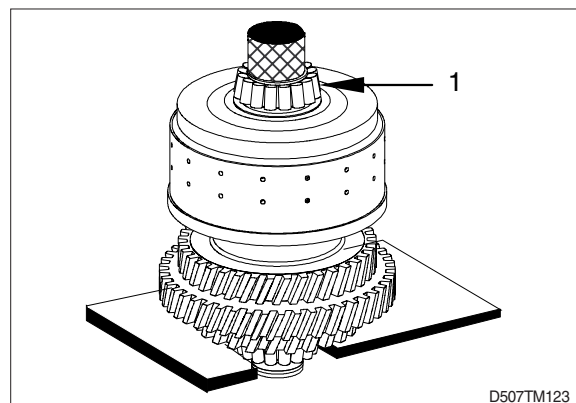

D507TM123

- ⑩ Press the taper roller bearing (inner ring) (1) until contact is obtained.

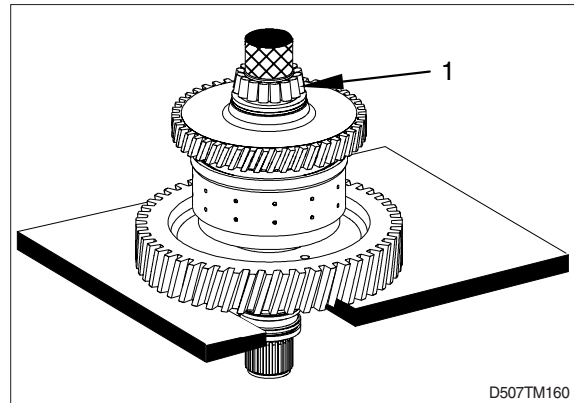

- ⑪ Install the piston ring (1).

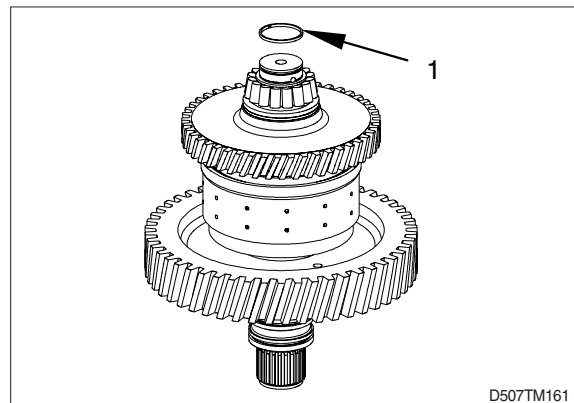

- ⑫ Install the screw plug (1).

(S) Lever riveting tongs 5870 320 016

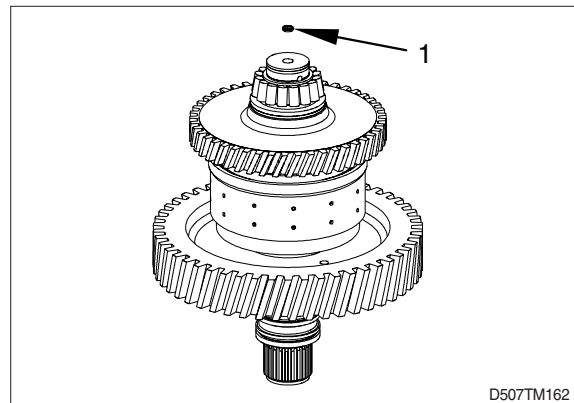

- ※ Check closing respective opening of the clutch by means of compressed air at the bore (1).  
Closing respective opening of the clutch must be clearly audible.

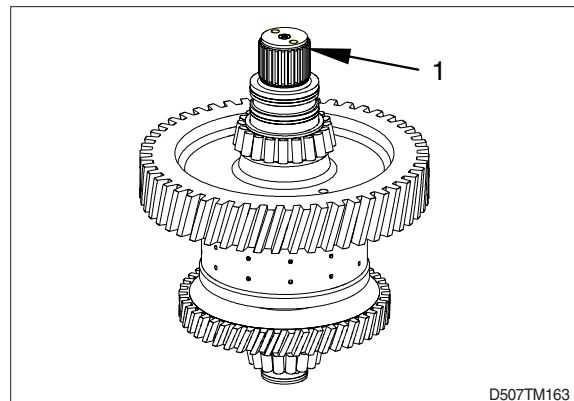

### 3) INDUCTIVE TRANSMITTERS, VALVES, OIL FILTERS AND OIL DRAIN PLUG, SCREW PLUGS

① Install the converter pressure back-up valve.

- 1 = Piston
- 2 = Compression spring
- 3 = O-ring (27 × 2)
- 4 = Screw plug (30 × 1.5)

※ Tightening torque .....  $M_A=10.2 \text{ kg} \cdot \text{m}$

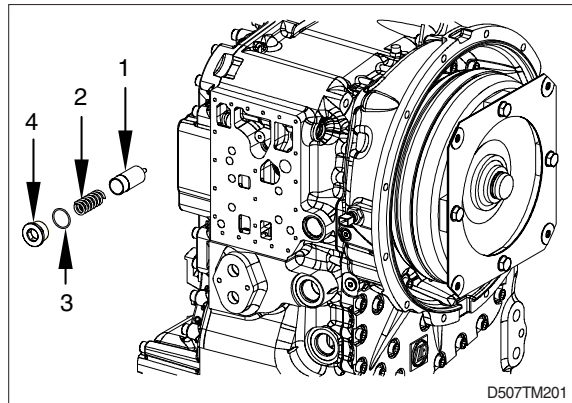

D507TM201

② Install the differential pressure switch for the pressure filter.

- 1 = Compression spring
- 2 = Piston
- 3 = Tappet switch

※ Tightening torque .....  $M_A=3.1 \text{ kg} \cdot \text{m}$

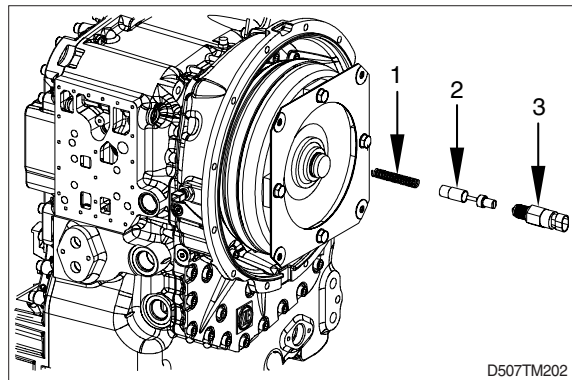

D507TM202

③ Installation of:

- 1 = Inductive transmitter - n Engine
- 2 = Screw plug M10 × 1.0  
(measuring point pressure after converter)
- 3 = Temperature transmitter M14 × 1.5  
(measuring point temperature after converter)

※ Tightening torque (1) .....  $M_A=3.1 \text{ kg} \cdot \text{m}$   
 Tightening torque (2) .....  $M_A=0.97 \text{ kg} \cdot \text{m}$   
 Tightening torque (3) .....  $M_A=2.6 \text{ kg} \cdot \text{m}$

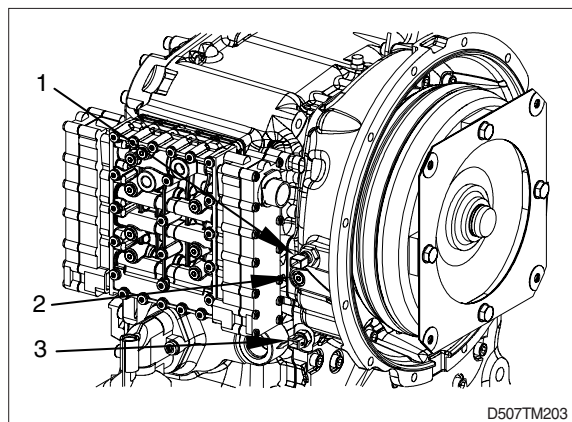

D507TM203

### **3. DRIVE AXLE DISASSEMBLY (DIC)**

#### **1) GENERAL INSTRUCTIONS FOR CORRECT ASSEMBLY AND DISASSEMBLY**

- (1) Disassembly and assembly are to be accomplished only by trained personnel.
- (2) The assembly can be made reverse to the respective disassembly instruction.
- (3) Drain oil before removing, check for presence of metal particles.
- (4) Mark the parts to each other before dismantle.
- (5) Never use a hard object to separate tightly fitted assemblies. To remove bearings, drive flanges and similar parts, use the proper pullers.
- (6) It is recommended that the special tools used for disassembly.
- (7) Do not place parts on a dirty surface.
- (8) Systematically replace used seals, O-rings and, if necessary, bearings on disassembly.
- (9) Clean parts before reassembly.
- (10) Replace or clean corroded parts.
- (11) The cages of bearings rotating in oil are to be coated with oil at reassembly.
- (12) Seal ring treads on flanges, shafts etc. must be preserved with SAE80W-90/API GL-5 before mounting.
- (13) Oil seal rings and particularly the anti-dust lip seals must be filled with grease.
- (14) The universal joint shafts and the axle shafts must not be force mounted(They must slide).
- (15) At mounting of radial seal rings pay attention that there is suffice overlap to the housing bores.  
Pay attention for a plain alignment of the radial seal ring. The seal lips always must not be contacted with Loctite.
- (16) The bolted or keyed assemblies safeties are to be checked according to instructions ; in case of doubt, consult Hyundai dealer.
- (17) Refill the oil after assembly.
- (18) Repair weldment is only allowed after consultation with Hyundai.

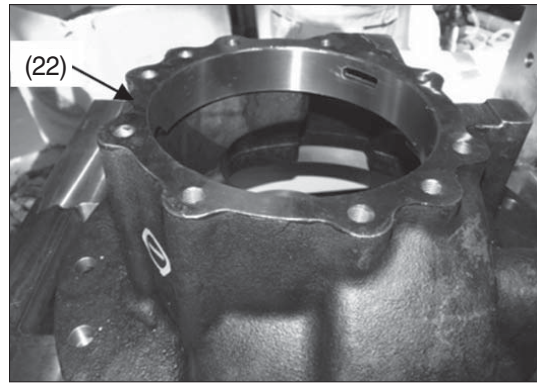

110DEDA46

- (9) Loosen nut (23) and disassemble the yolk (24) from differential flange assembly.

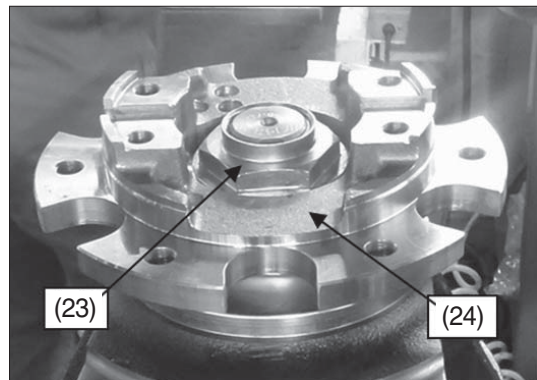

110DEDA47

- (10) Disassemble the pinion shaft (25) from the differential flange (29) by using tools.

- ⚠ Be careful imprints on the pinion shaft and oil seal damage.



110DEDA48

(4) Assemble the preassembled wheel hub and spline collar with the brake cover assy. Assemble the disc, plate and 6 brake pins and apply loctite #5217 on the assemble surface.

110/130D-9	Disc	4 piece
	Plate	7 piece
160D-9	Disc	5 piece
	Plate	6 piece

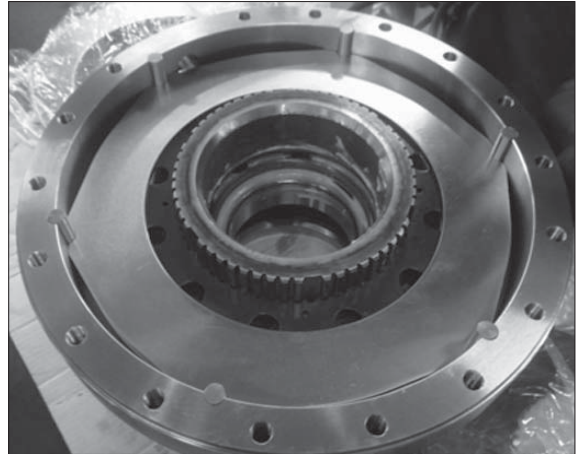

110DEDA72

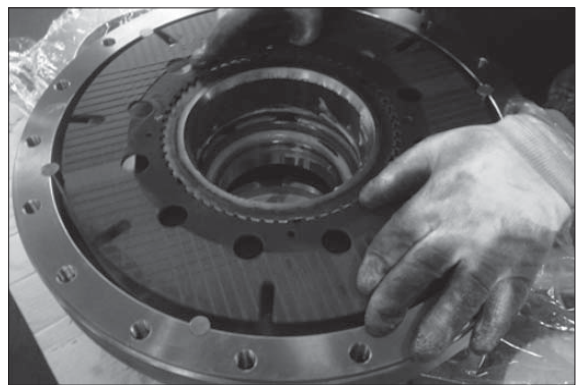

110DEDA73



110DEDA74

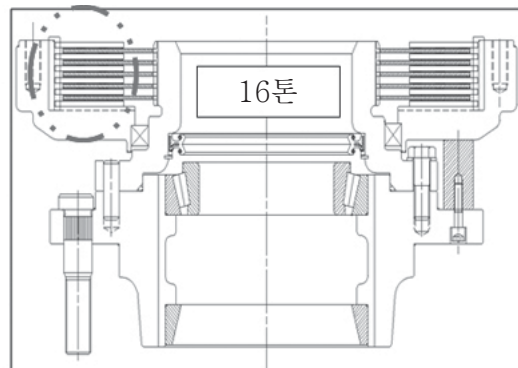
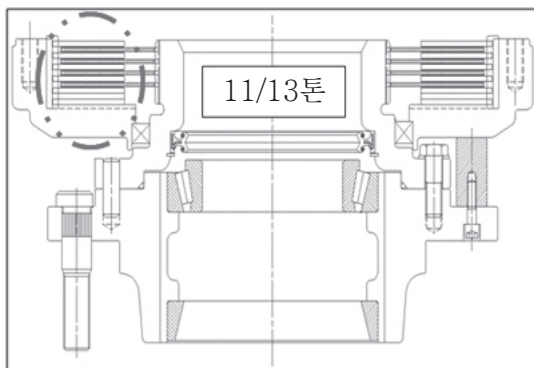

110DEDA74-1

※ In case the 110/130D-9, assemble 3 piece plates on the bottom of the brake cover at first.

(2) Tightening torques for castle nuts on ball joints for track rods and ram cylinders

The tightening torques of the different thread dimensions of the joints are applicable for nuts of quality S6.

Cone size d1 (mm)	Thread d2 (mm)	Torque (Nm)
26	M20 × 1.5	200~220
30	M24 × 1.5	280~300
32	M27 × 1.5	290~320
38	M30 × 1.5	340~360
45	M39 × 1.5	410~430

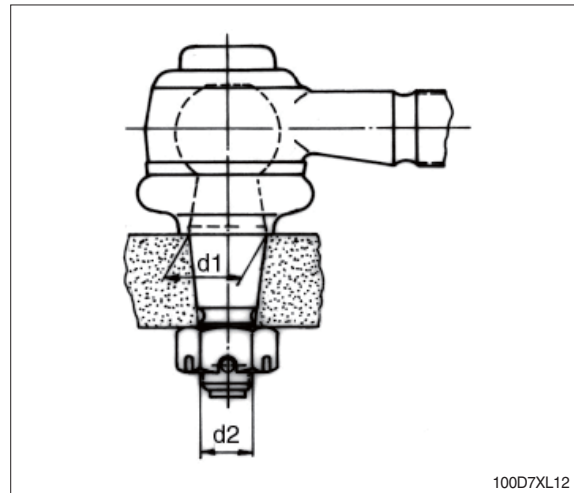

(3) Tightening torque of the adjusting nut respective slotted nut at flanges respective gear wheels ect.

Thread d1 (mm)	Torque (Nm)
M20 × 1.5	360
M30 × 1.5	450
M36 × 1.5	540
M42 × 1.5	850
M45 × 1.5	850
M48 × 1.5	850
M52 × 1.5	950
M64 × 1.5	1050~1100

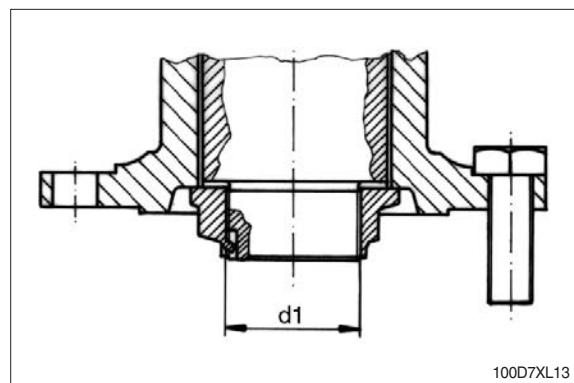

## 9) ASSEMBLY OF DRIVE ASSEMBLY

- (1) Place the differential with the outer rings of the taper roller bearings on the differential carrier which is in a vertical position, with mounted drive pinion.
- (2) Mount the differential straps and align them with the thread rings.
- (3) During this operation be careful of the alignment marks on the differential straps with respect to the differential carrier. (Do not interchange the differential straps)

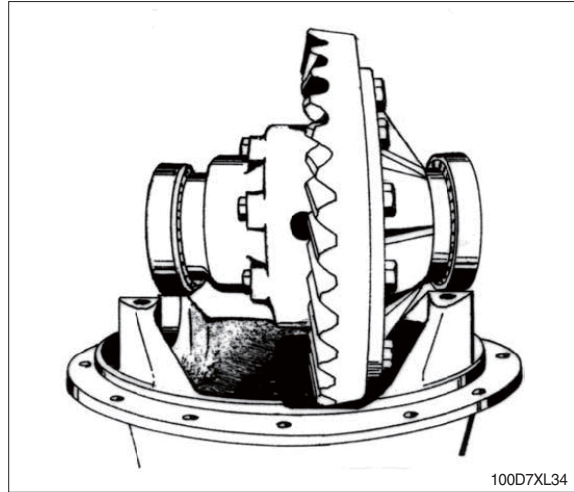

- (4) Hand tighten the differential strap bolts. By a counter rotation of the two thread rings, move the differential until the backlash is correct. (The smallest admissible value at the closest place is marked on the ring gear)
- (5) Therefore hold the drive pinion at the drive flange. Check the backlash by careful forwards and rearwards rotating the ring gear. Use a dial indicator.
- (6) Measure the backlash during a few times turns of the ring gear and if need correct the backlash, because of the smallest admissible value at the closest place must not be fall short of.

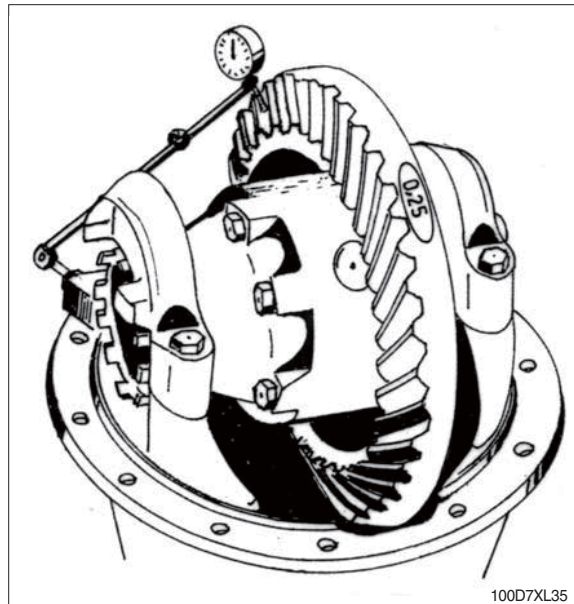

- (7) Adjust gear meshing according to page 3-164 "Adjustment of gear meshing of Gleason gears".
- (8) Tighten screws of the differential straps and lock them with Loctite 262.
- (9) Adjust the bearing roll resistance through tightening of the thread rings. Set value : 2.0 to 3.0Nm. Check the value with a torque wrench. If measuring at the drive pinion/drive flange, take the ratio of the bevel wheel set into account.
- (10) Screw the lock plates for the thread rings and secure with Loctite 270, if need bend the lock plates.

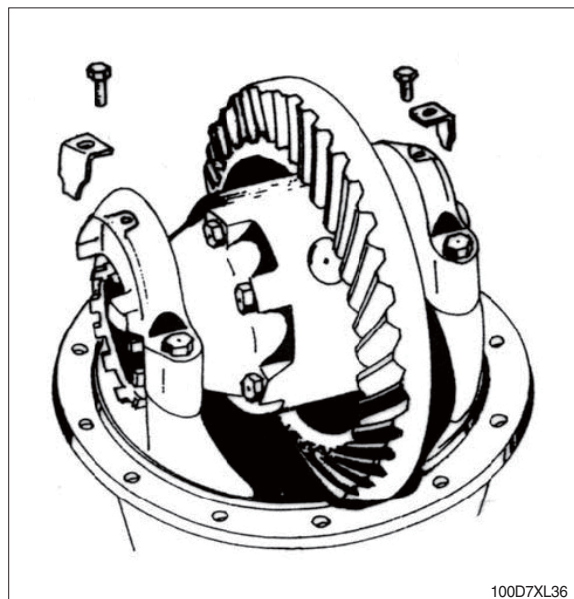

### (5) Assembly of planetary gear

- ① Prepare planetary gear :  
Install the needle bearing (10, 11) into the planetary gear (12, 13).

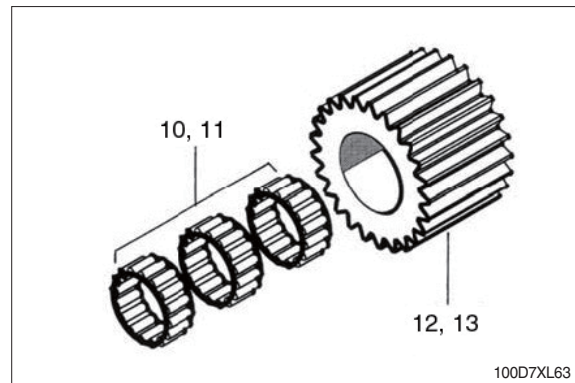

- ② Insert the preassembled planetary gears (12, 13) with needle bearings (10, 11), rings (16) (if present) and thrust disks (14, 15) into the planetary housing (22, 23) (planetary housing in horizontal position).

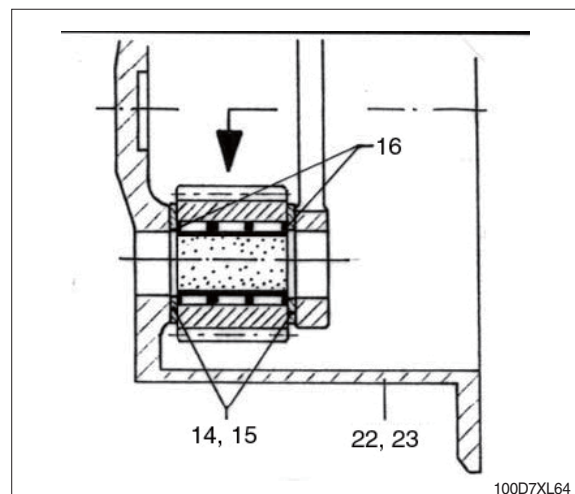

- ③ Place O-ring (19) into the slot of the planetary housing (22). Because of the difference of diameter of 0.1mm press the planetary pin (17, 18) in direction of arrow. Be sure, that the bore hole of the locking pin in the planetary pin and planetary housing are aligned. After inserting, secure the planetary pin with the locking pin (20, 21).

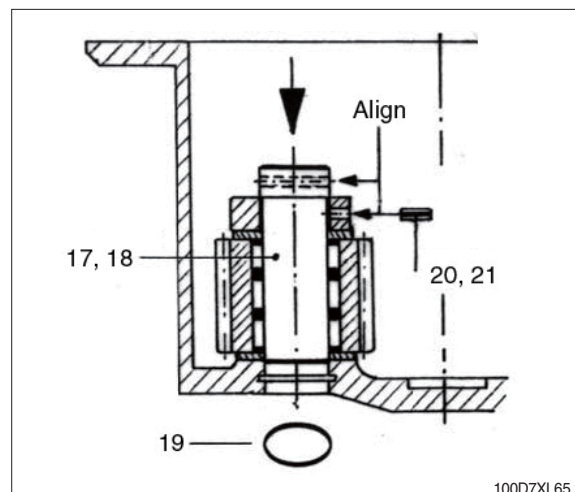

(9) Brake disk

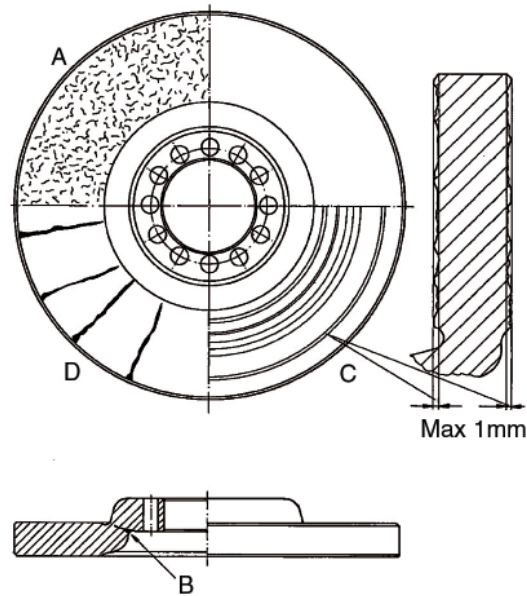

A	Network - like formation of cracks	admissible
B	Radially shaped crack	not admissible
C	Uneven brake surface characteristics below 1.0 mm	admissible
D	Continuous cracks	not admissible

100D7XL78

(10) Spring - loaded sliding caliper brakes

**Safety notes :**

· **Warning**

Before commencing work on the parking brake, ensure that no unintended machine movement can happen when the braking effect is removed.

· **Danger**

The parking brake is under spring tension. Parts could become loose and fly out suddenly if improper brake opening. Therefore release the lock nut (2) and turn the adjusting screw (3) counter - clockwise until the spring set is released before disassembly of the circlip (1).

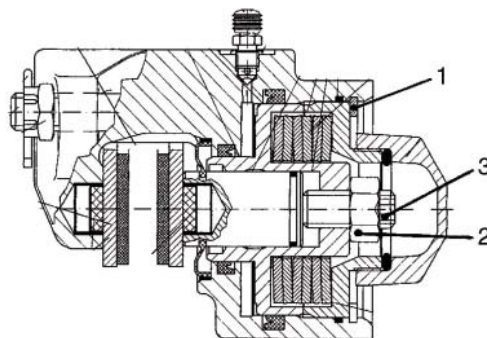

100D7XL79

# 1) SERVICE BRAKE RELEASED

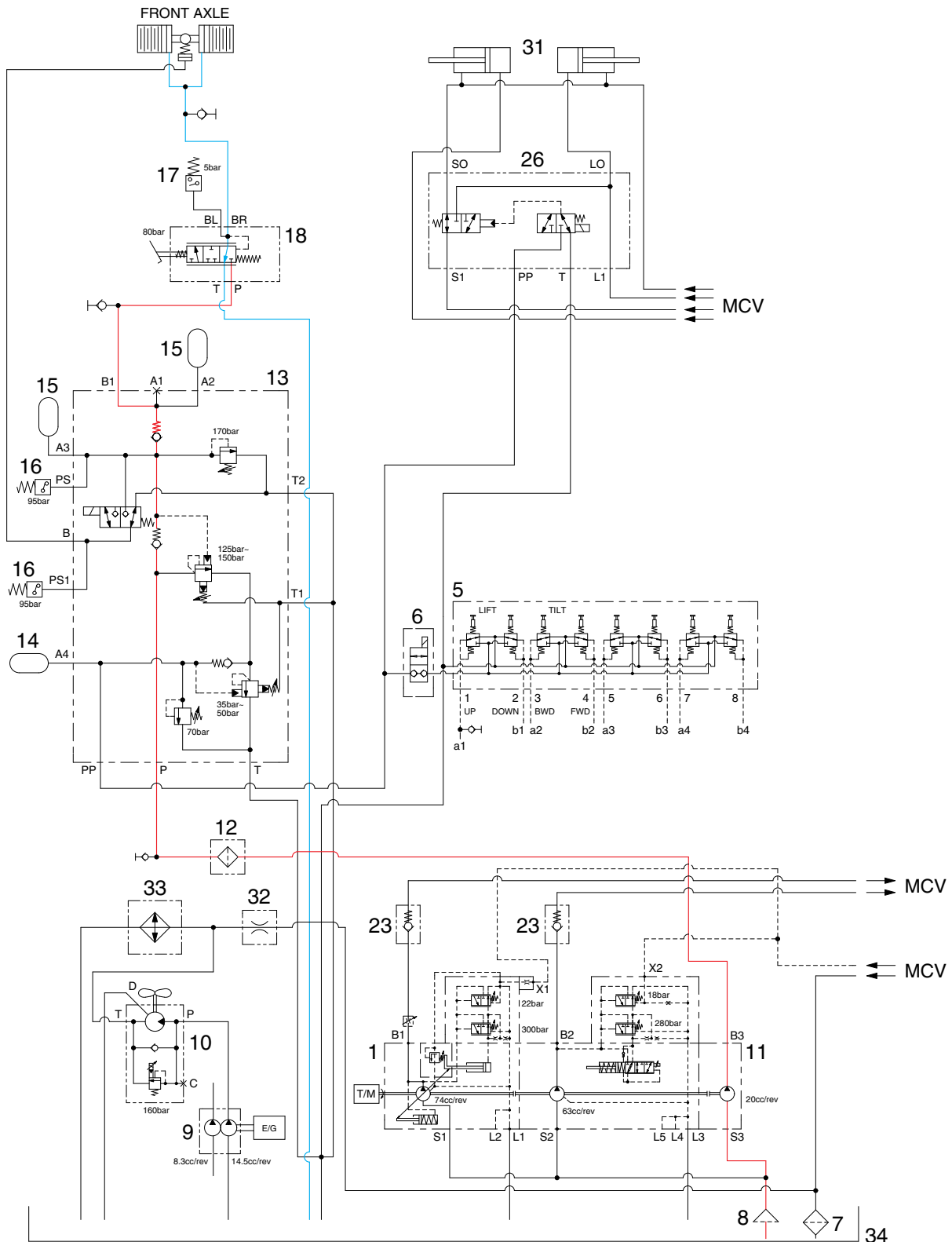

110D9BS02

When the pedal of brake valve (18) is released, the operating force is eliminated by the force of the spring, and the spool is returned.

When the spool removes up, the drain port is opened and the hydraulic oil in the piston of axles return to the tank (34).

Therefore, the service brake is kept released.

CLICK HERE TO **DOWNLOAD** THE COMPLETE MANUAL

- Thank you very much for reading the preview of the manual.
- You can download the complete manual from: [www.heydownloads.com](http://www.heydownloads.com) by clicking the link below



- Please note: If there is no response to CLICKING the link, please download this PDF first and then click on it.

CLICK HERE TO **DOWNLOAD** THE COMPLETE MANUAL

## (2) BASIC SETTING REGULATION

- ① Turn the adjusting screw manually clockwise until both brake pads make contact with the brake disk. Then it is not longer possible to turn the adjusting screw without exerting a major amount of force.
- ② Turn the adjusting screw anticlockwise in order to set the following rated clearances.

Model	Adjusting screw	Clearance (mm)		Turns
		Min.	0.5	
110/130/160D-9	M16 (SW 8)	Clearance	1.0	1/2
		Max.	1.5	3/4

- ③ Hold the adjusting screw in position with a hexagonal socket wrench and lock with lock nut.
  - ④ Mount the screw cap and tighten as far as possible manually.
  - ⑤ Mount the pressure connection in accordance with the instructions of the axle.
- ※ For bleeding the piston chamber use the socket spanner size 13 for the bleeding valve.

## (3) ADJUSTING REGULATIONS

During this adjusting process, the parking brake must be released, i.e. the bank of cup springs must be completely pre-tensioned.

- ① Stand the vehicle on an even surface and secure against rolling away.
  - ② Release the parking brake by using the required release pressure.
  - ③ Release the screw cap and unscrew.
  - ④ Release the lock nut (size 24 or 30) and turn the adjusting screw with socket wrench size 8 or 10 manually clockwise until the two brake pads make contact with the brake disk.
  - ⑤ Turn the adjusting screw anti-clockwise and set the clearance specified in the above table.
  - ⑥ Hold the adjusting screw in position with the hexagonal socket wrench and lock with the lock nut.
  - ⑦ Mount the screw cap and tighten as far as possible manually.
- ※ Actuate the brake valve several times and check the braking efficiency of the parking brake on a slope.

## 6. CUT-OFF VALVE

### 1) STRUCTURE

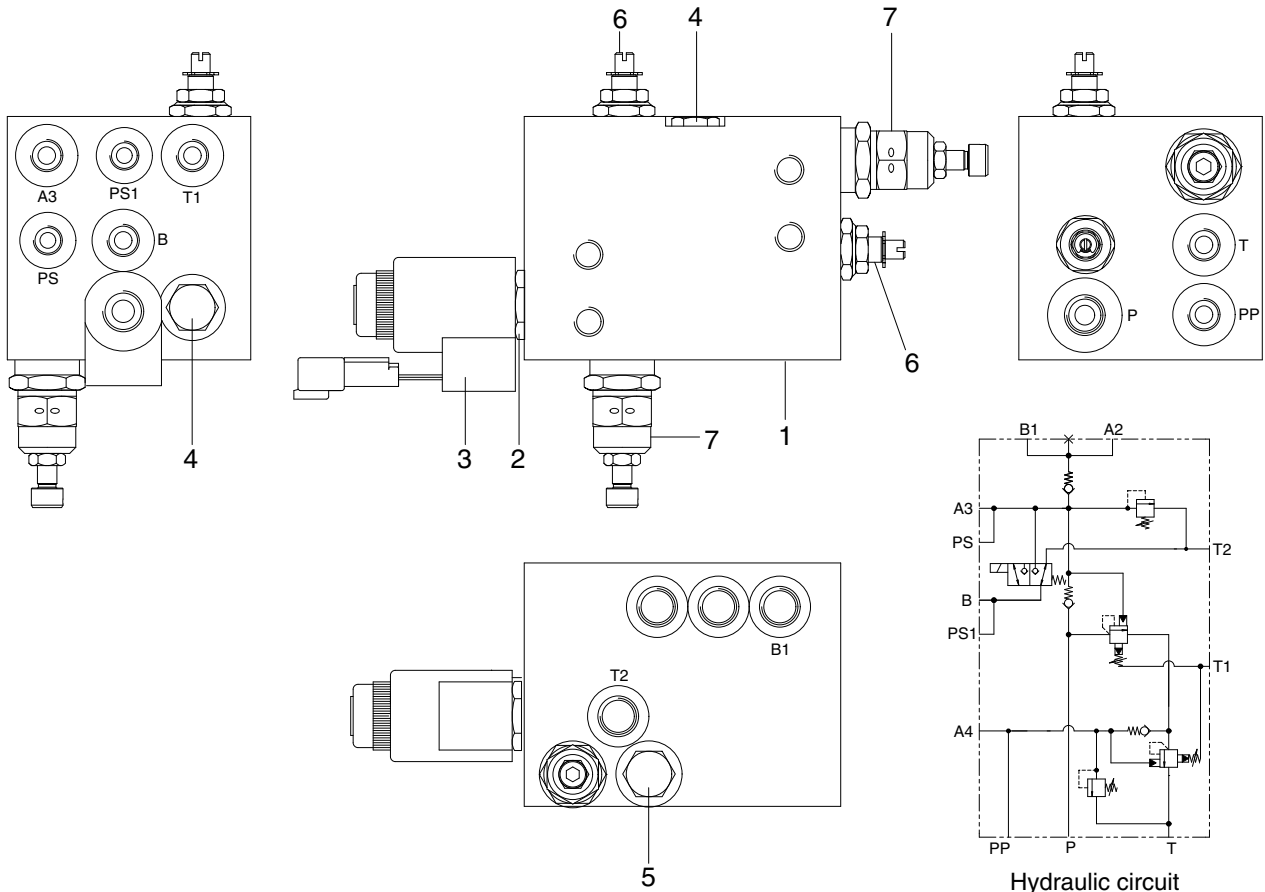

- |   |                |   |               |
|---|----------------|---|---------------|
| 1 | Manifold       | 5 | Check valve   |
| 2 | Solenoid valve | 6 | Cut-off valve |
| 3 | Coil           | 7 | Relief valve  |
| 4 | Check valve    |   |               |

### 2) OPERATION

When the pump works, the oil under the pressure flows into P port.

The oil in P port is stored in the accumulator on A3 port.

As the pressure on P line rises to 150 bar, the cut off valve (6) starts cut-offting and the oil in the P port is unloaded. The pressure on P line goes down 120 bar by the minute leakage from valve and other factors.

At this pressure, the cut-off valve starts cutting.

This process is repeated in the regular period of 30~40 seconds.

110D9BS35

※ Hydraulic oil must be at operating temperature for these checks.

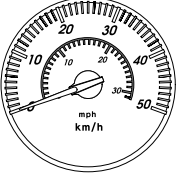
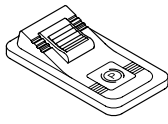
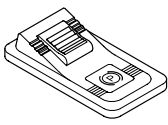
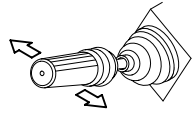
Item	Description	Service action
<p><b>Parking brake capacity check</b> Seat belt must be worn while doing this check to prevent possible injury when machine stops suddenly.</p>	  <p>Start engine. Fasten seat belt. Release parking brake and put transmission in 2nd gear forward. Drive machine at 8 km/hr and switch parking brake ON. <b>LOOK/FEEL</b> : Machine must come to a stop within 2 meters(6 feet) when parking brake is engaged at 8 km/hr. Transmission must shift to neutral.</p>	<p><b>OK</b> Check completed. <b>NOT OK</b> Inspect parking brake. Go to group 3.</p>
<p><b>Parking brake transmission lockout check</b> Engine running.</p>	  <p>Turn parking brake to ON. Place transmission in 1st forward. Slowly increase engine speed to high idle. <b>LOOK</b> : Machine must not move.</p>	<p><b>OK</b> Check completed. <b>NOT OK</b> Go to transmission control circuit in section 3.</p>

## GROUP 4 DISASSEMBLY AND ASSEMBLY

### 1. BRAKE PUMP

#### 1) STRUCTURE

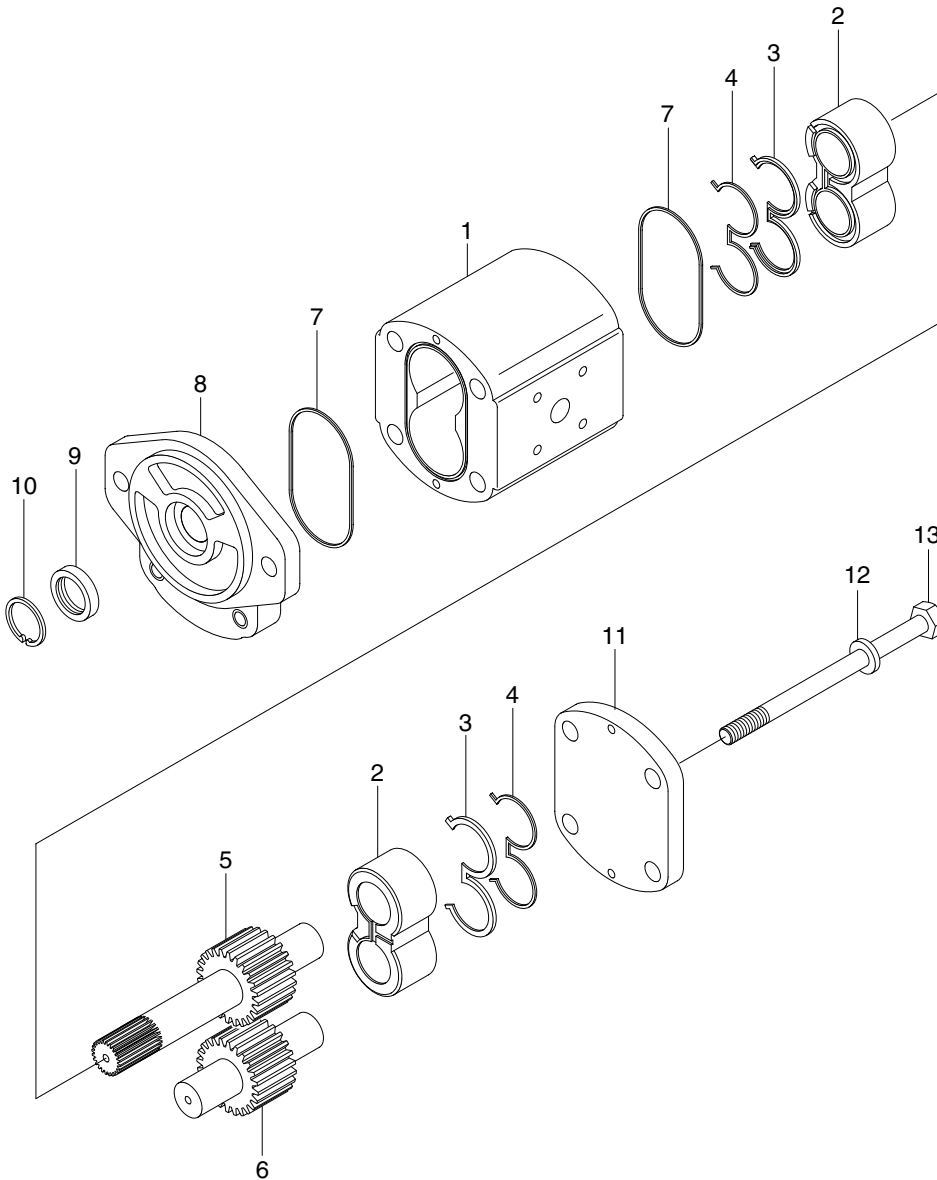

- |   |              |    |               |
|---|--------------|----|---------------|
| 1 | Housing      | 8  | Front cover   |
| 2 | Bush block   | 9  | Retainer seal |
| 3 | Backup seal  | 10 | Snap ring     |
| 4 | Channel seal | 11 | Rear cover    |
| 5 | Shaft gear   | 12 | Washer        |
| 6 | Driven gear  | 13 | Bolt          |
| 7 | O-ring       |    |               |

180D7EBP00

## 2. HYDRAULIC CIRCUIT

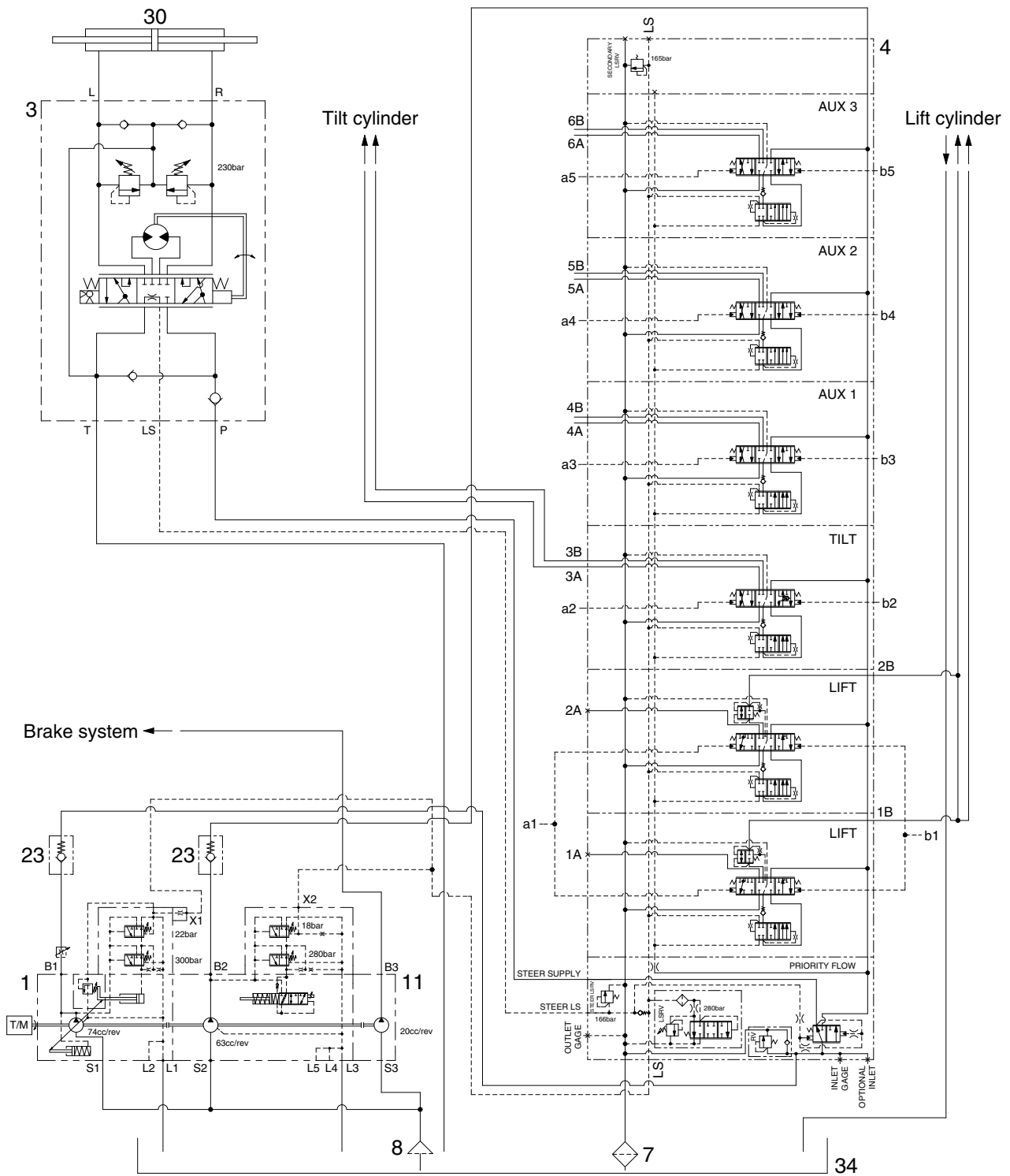

- |   |                    |    |                   |
|---|--------------------|----|-------------------|
| 1 | Main pump          | 11 | Brake pump        |
| 3 | Steering unit      | 23 | Check valve       |
| 4 | Main control valve | 30 | Steering cylinder |
| 7 | Return filter      | 34 | Hydraulic tank    |
| 8 | Suction strainer   |    |                   |

110D9SS02

Problem	Cause	Remedy
<b>Slow or hard steering</b>	Too much friction in the mechanical parts of the machine  Cold oil  Low priority valve pressure setting  Worn hydraulic pump  Sticking priority valve spool  Broken priority valve spring	Lubricate bearings and joints of steering column or repair if necessary. Check steering column installation.  Warm the hydraulic oil.  Do priority valve pressure test. Clean or replace cartridge in steering valve.  Do hydraulic pump performance check.  Remove and inspect.  Remove and inspect.
<b>Constant steering to maintain straight travel</b>	Air in system  Leakage in steering system  Worn steering unit    Leaf spring without spring force or broken  Spring in double shock valve broken  Gear wheel set worn  Cylinder seized or piston seals worn	Check for foamy oil.  Do steering system leakage check.  Do steering system leakage check. Do steering unit neutral leakage test in group 3.  Replace leaf springs.  Replace shock valve.  Replace gear wheel set.  Replace defects parts.
<b>Slow steering wheel movement will not cause any frame movement</b>	Leakage in steering unit gerotor  Worn steering unit gerotor	Do steering system leakage check.  Do steering leakage check.
<b>Steering wheel can be turned with frames against steering stop</b>	Leakage in steering system	Do steering system leakage check.
<b>Steering wheel turns with no resistance and causes no frame movement</b>	Broken steering column or splined coupling  Lack of oil in steering unit  Leakage in steering system	Remove and inspect.  Start engine and check steering operation.  Do steering system leakage test in group 3.

**2) TOOLS**

(1) Holding tool + Guide ring

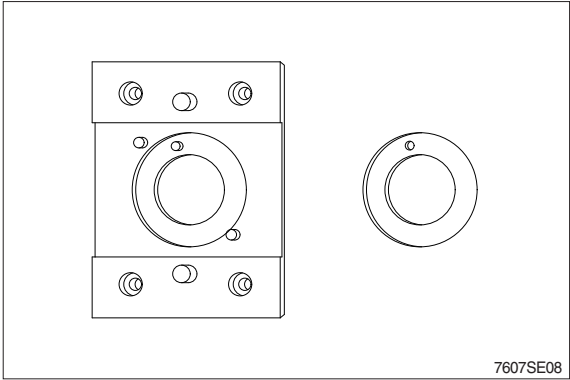

(2) Assembly tool for O-ring and kin-ring.

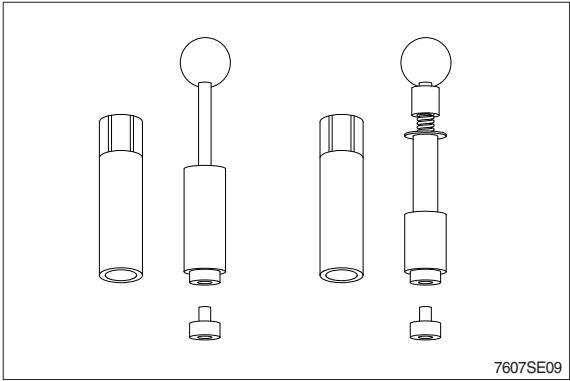

(3) Assembly tool for lip seal.

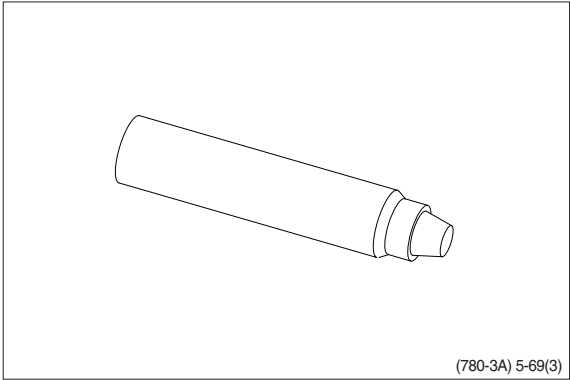

(4) Assembly tool for cardan shaft.

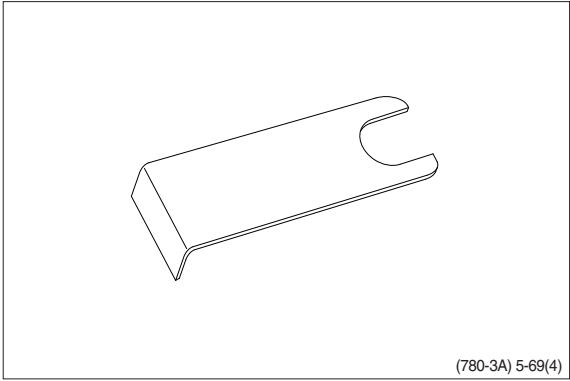

(3) Install the dust wiper to the gland using a special installing tool. Coat the dust wiper with grease slightly before installing.

(4) Using a special tool, install gland assembly into the cylinder tube.

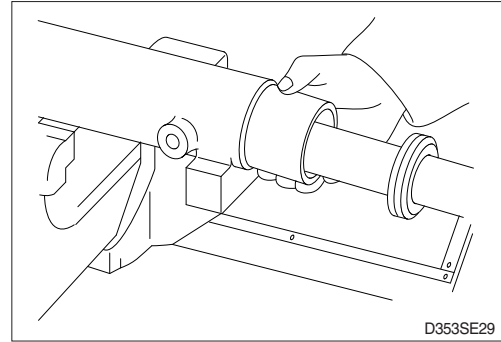

(5) Using a hook spanner, install the gland assembly, and tighten it with torque  $60 \pm 6$  kgf · m ( $434 \pm 43$  lbf · ft).

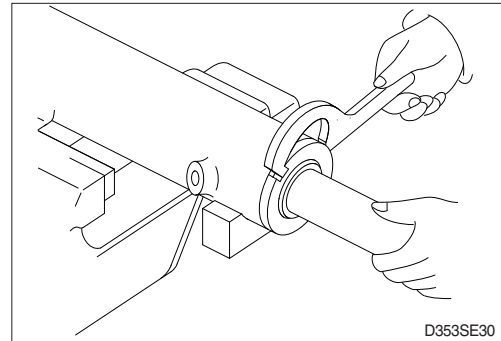

(6) After the gland assembly was installed to the cylinder tube, calk at the tube end into the groove on the gland to prevent screw loosening.

※ If it is needed to calk again, never calk on the same place.

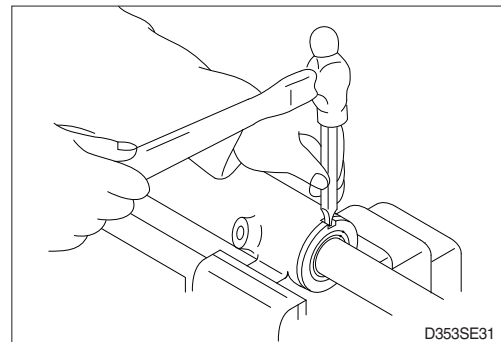

(7) Move the piston rod back and forth several times for the full distance of its stroke. This helps to seat the ring and seals before applying full hydraulic pressure to the cylinder.

(8) Install cylinder into trail axle.

(9) While idling the engine with the rear wheels off the ground, operate the steering wheel left and right alternately.

※ Then, repeat the above operation at gradually increasing engine rpm. This releases air from the system and completes preparation for operation.

(10) Stop the engine, lower the floating rear wheels, and check pump joints for oil leaks and looseness and retighten, them as required.

# 1) WHEN THE LIFT CONTROL LEVER IS IN THE LIFT POSITION

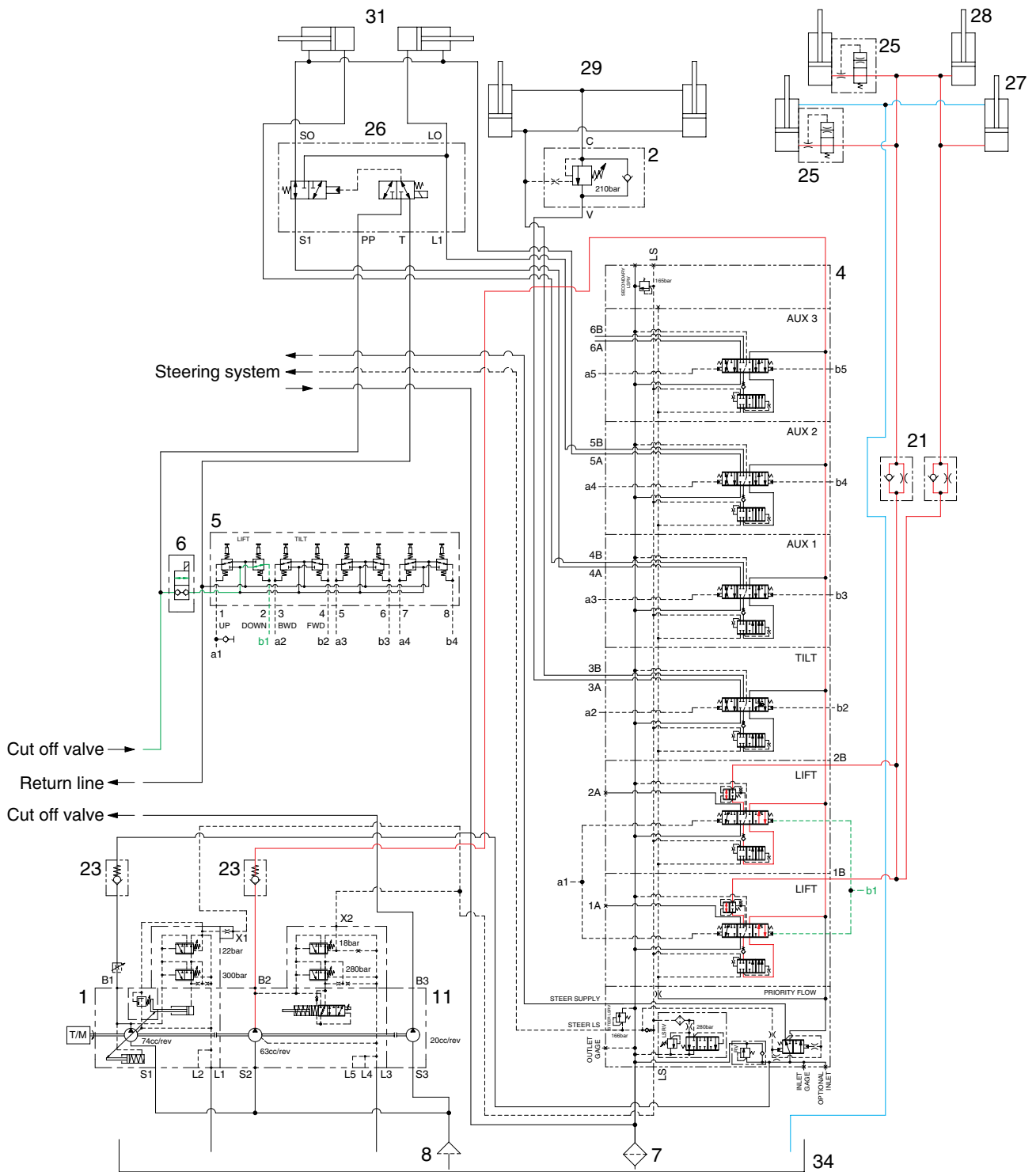

110D9HS03

When the lift control lever is pulled back, the spool is moves to lift position by the pilot oil pressure from the remote control valve (5).

The oil from hydraulic main pump (1) flows into main control valve (4) and then goes to the large chamber of lift cylinder (27) by pushing the load check valve of the spool.

The oil from the small chamber of lift cylinder (27) returns to hydraulic oil tank (34) at the same time.

When this happens, the forks go up.

Control piston (10) diameter is larger than counter piston (4) diameter, the oil pressure that is acting against control piston (10) overcomes the force of counter spring (6). The oil pressure then causes the pump to destroke.

Pressure and flow compensator valve (7) also controls the maximum output of pump pressure. When steering and loader pressure rises above pressure compensator setting, pressure compensator spool (12) overrides flow compensator spool (13). This causes the pump to destroke.

# STRUCTURE

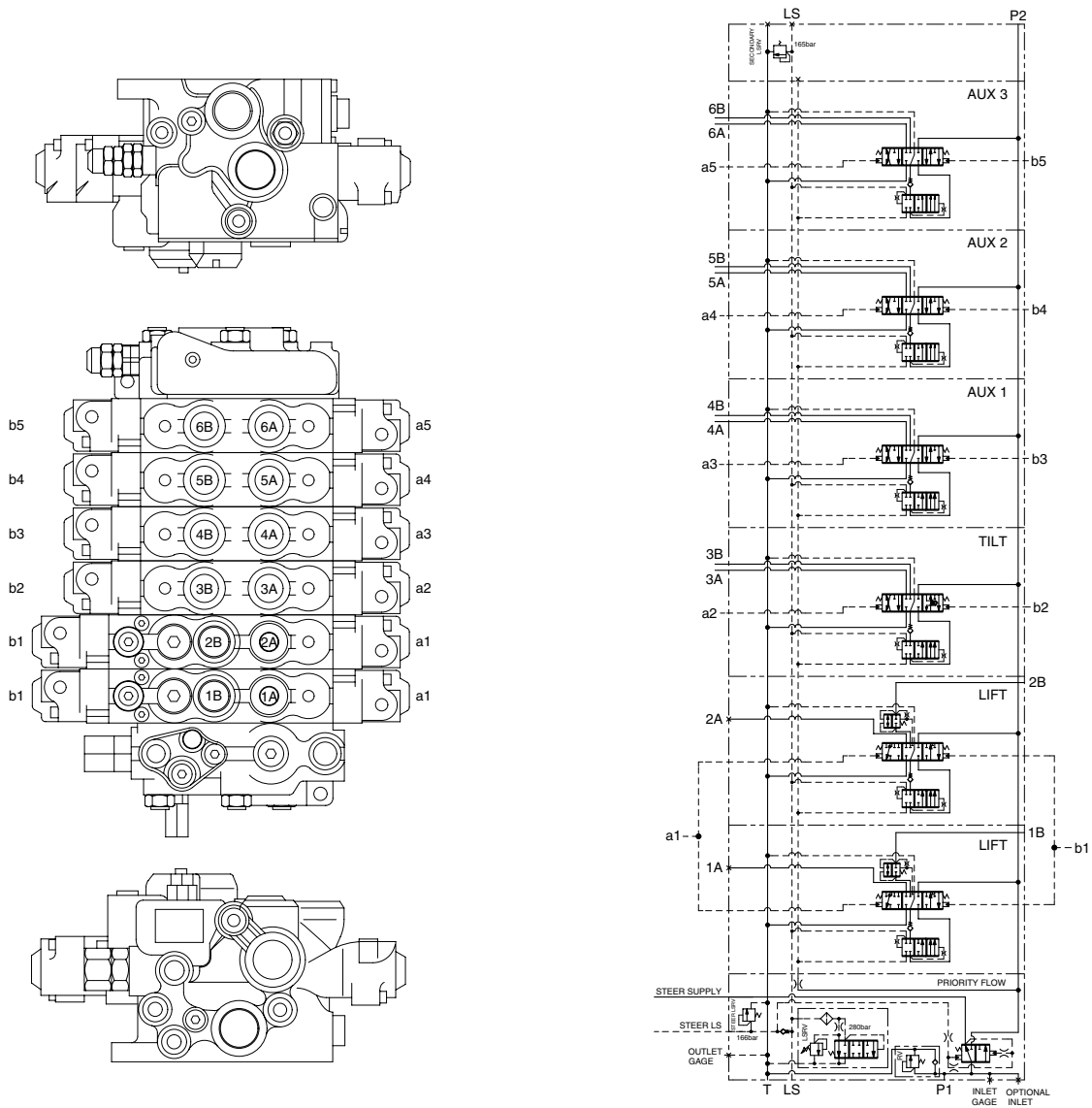

110D9HS10

Port	Port name	Size	Port	Port name	Size
P1, P2	Inlet port	1 5/16" - 12UNF	6A, 6B	To aux port	1 1/16" - 12UNF
T	Outlet port	1 5/16" - 12UNF	a1, b1	To lift pilot port	9/16" - 18UNF
1A, 2B	To lift cylinder port	1 1/16" - 12UNF	a2, b2	To tilt pilot port	9/16" - 18UNF
3A, 3B	To tilt cylinder port	1 1/16" - 12UNF	a3, b3	To aux pilot port	9/16" - 18UNF
4A, 4B	To aux cylinder port	1 1/16" - 12UNF	a4, b4	To aux pilot port	9/16" - 18UNF
5A, 5B	To aux cylinder port	1 1/16" - 12UNF	a5, b5	To aux pilot port	9/16" - 18UNF

## GROUP 2 OPERATIONAL CHECKS AND TROUBLESHOOTING

### 1. OPERATIONAL CHECKS

#### 1) CHECK ITEM

- (1) Check visually for deformation, cracks or damage of rod.
- (2) Set mast vertical and raise 1 m from ground. Wait for 10 minutes and measure hydraulic drift (amount forks move down and amount mast tilts forward).

· **Check condition**

- Hydraulic oil : Normal operating temp
- Mast substantially vertical.
- Rated capacity load.

· **Hydraulic drift**

- Down (Downward movement of forks)  
: Within 100 mm (3.9 in)
- Forward (Extension of tilt cylinder)  
: Within 5°

- (3) If the hydraulic drift is more than the specified value, replace the control valve or cylinder packing.

Check that clearance between tilt cylinder bushing and mounting pin is within standard range.

	mm (in)
Standard	Under 0.6 (0.02)

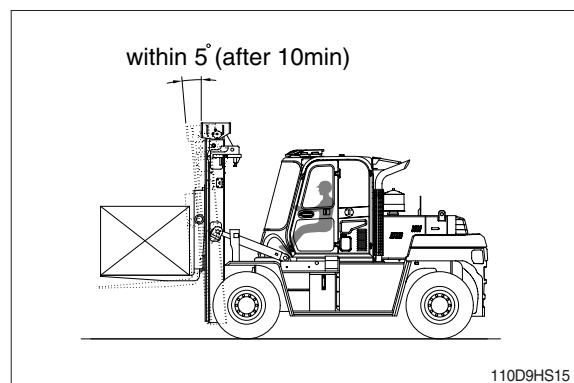
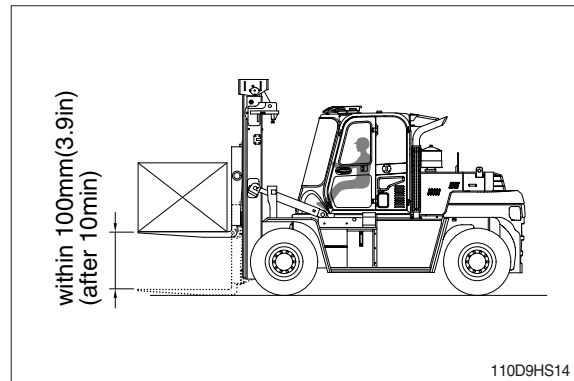

#### 2) HYDRAULIC OIL

- (1) Using dipstick, measure oil level, and oil if necessary.
- (2) When changing hydraulic oil, clean suction strainer (screwed into outlet port pipe) and line filter (screwed into inlet pipe). Line filter uses paper element, so replace periodically (every 6 months or 1000 hours)

#### 3) CONTROL VALVE

- (1) Raise forks to maximum height and measure oil pressure.  
Check that oil pressure is 210 kgf/cm<sup>2</sup>.  
(2990 psi)

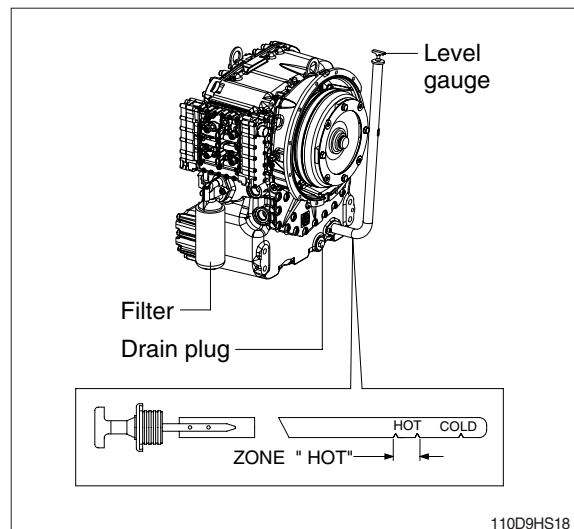

(6) Remove swash plate and bearing shells.

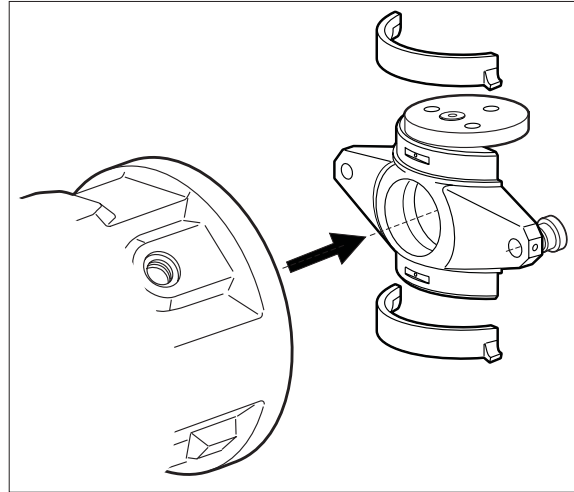

75796WE68

(7) Remove the circlip and the shaft seal.

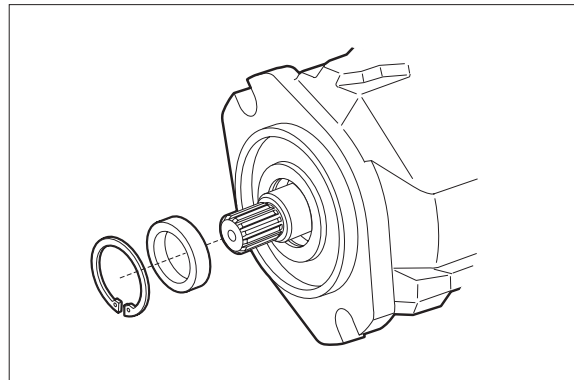

75796WE69

(8) Remove the drive shaft through rear side.

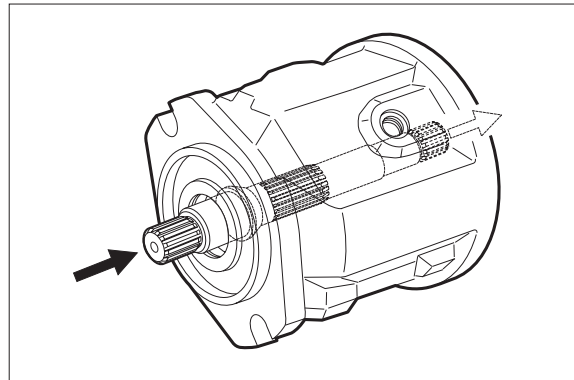

75796WE70

(9) Pre-tension the spring (1) using a suitable device.  
Remove circlip (2).  
Remove spring (1) and pressure pins (3).

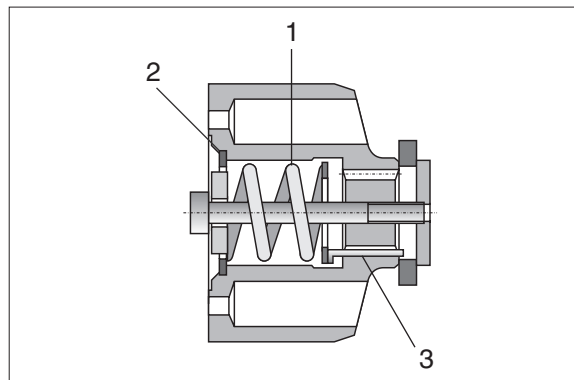

75796WE72

## 2) SPOOL SECTION

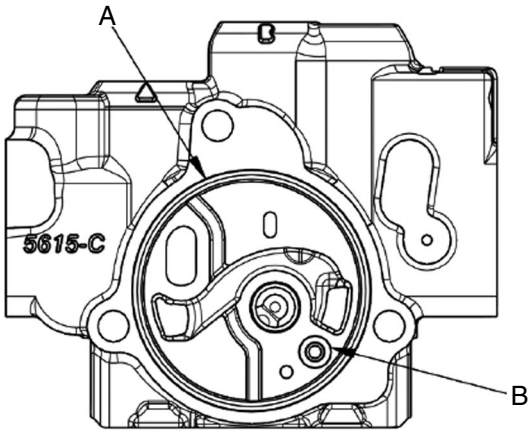

FIGURE #1 - SPOOL SECTION VIEW

A - Large O-ring

B - Small O-ring

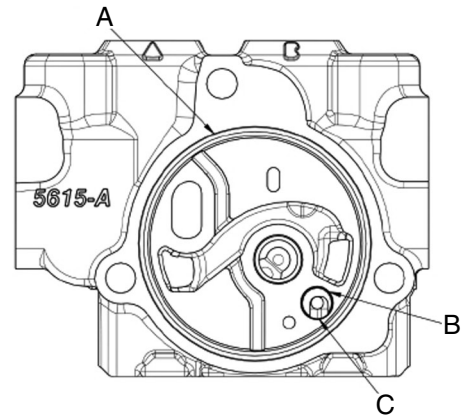

FIGURE #2 - SPOOL SECTION VIEW

A - Large O-ring

B - Seat assy (CV Valve)

C - Small O-ring

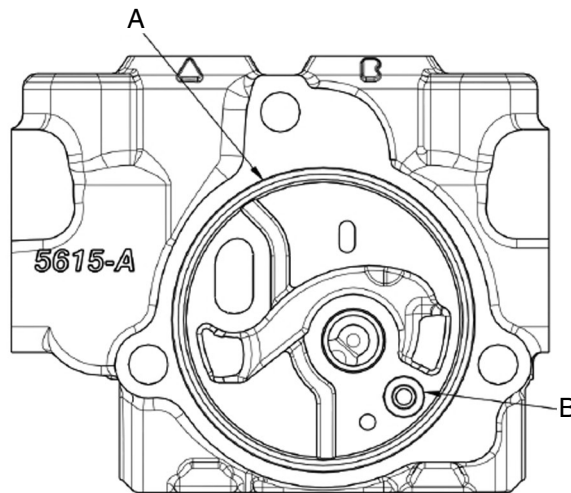

FIGURE #3 - SPOOL SECTION VIEW

A - Large O-ring

B - Small O-ring

110DEMCV01

### 3. MAIN CONTROL VALVE (FINGERTIP TYPE)

#### 1) VALVE SECTION DISASSEMBLY / REASSEMBLY INSTRUCTIONS

- (1) Clean valve assembly thoroughly to remove any dirt and debris.
- (2) Remove nuts (10) and tie rods (9) from control valve (see Figure #4). Separate sections being careful not to lose section O-rings (A, B, C and D , Figure #1-3). Keep all components for each section together as a set.
- (3) Lay out valve components on a clean, flat working surface. The inlet assembly will include O-rings, and the spool section(s) will include O-rings. Tools required for basic valve assembly include 19 mm open or box end wrench and a torque wrench with thin wall sockets.
- (4) Inspect parts for wear or damage. Replace as necessary.
- (5) Restack valve as shown in Figure #4. Care should be taken to assure that the mating section surfaces are absolutely free of contamination (dirt, paint, paint chips, etc.). Care should be taken to not pinch the section O-ring when restacking the valve.  
Using the following procedure for stacking the valve assembly will help eliminate the possibility of damaged seals and will allow easy examination of the surfaces for debris.  
Tie rods (9) are threaded to different lengths on each end. Install nuts (10) fully onto the short thread end of each tie rod. Lay inlet section on its outside face with tie rods up. Install O-rings ( A, B and C ) in grooves on inlet face. Slide spool section (2) over tie rods and install O-rings ( A, B and C, Figure #1). Repeat for the remaining spool sections.  
After stacking all spool sections and inlet / outlet sections onto tie rods (9) and nuts (10) onto tie rods and hand tighten so valve assembly can be placed on its mounting feet before torquing tie rods.
- (6) Position valve assembly with the mounting pads of the end sections on a flat surface. To obtain proper alignment of end sections relative to the spool sections apply downward pressure to the end sections; snug tie rod ends to approximately 1.4 kgf·m (10 lbf·ft). Final torque the six 19 mm nuts (10) to 9.3 kgf·m (67 lbf·ft). Check for proper spool movement.
- (7) Install auxiliary valves and/or port plugs into all sections and torque to proper specifications.

## 12) END CAP ASSEMBLY (OPTION)

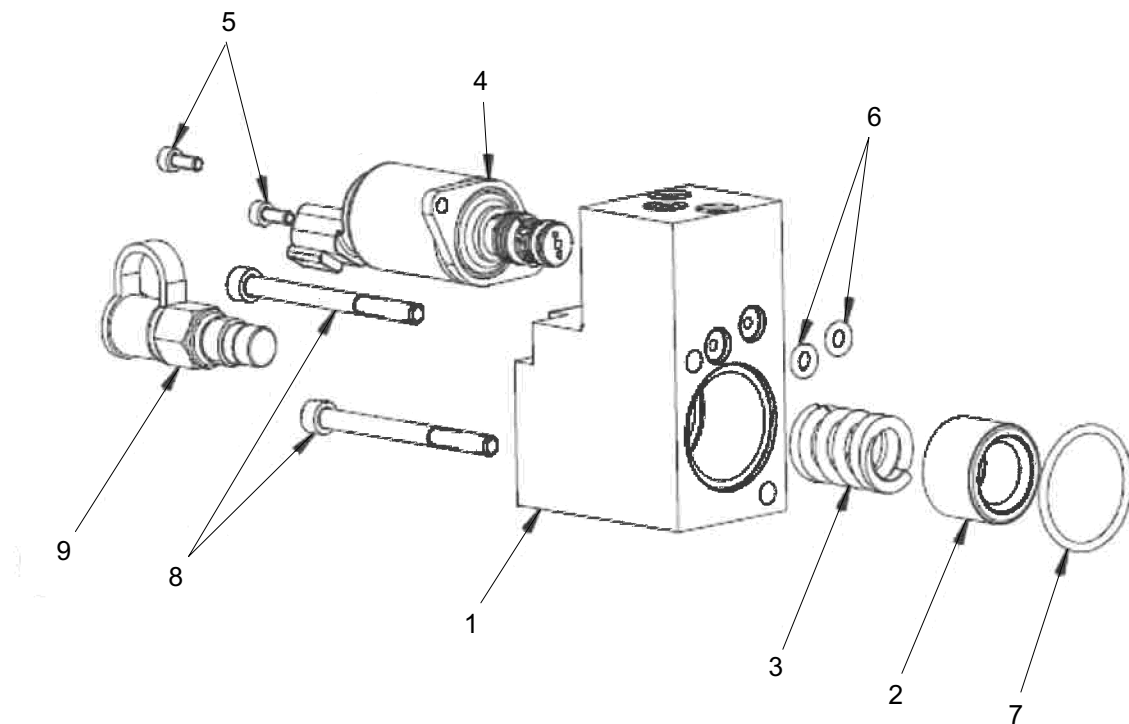

160D9LMCV11

### ※ Tightening torque

Item	Torque	Item	Torque
5	0.21 ± 0.03 kgf·m (1.5 ± 0.2 lbf·ft)	9	2.5 ± 0.3 kgf·m (18 ± 2 lbf·ft)
8	1.4 ± 0.14 kgf·m (10 ± 1 lbf·ft)	-	-

- |   |                         |   |                          |   |                       |
|---|-------------------------|---|--------------------------|---|-----------------------|
| 1 | Solenoid spool cap assy | 4 | Solenoid cartridge valve | 7 | O-ring                |
| 2 | Spring seat             | 5 | Socket head cap screw    | 8 | Socket head cap screw |
| 3 | Spring                  | 6 | O-ring                   | 9 | Adjust plug assy      |

## 2. LOCATION 2

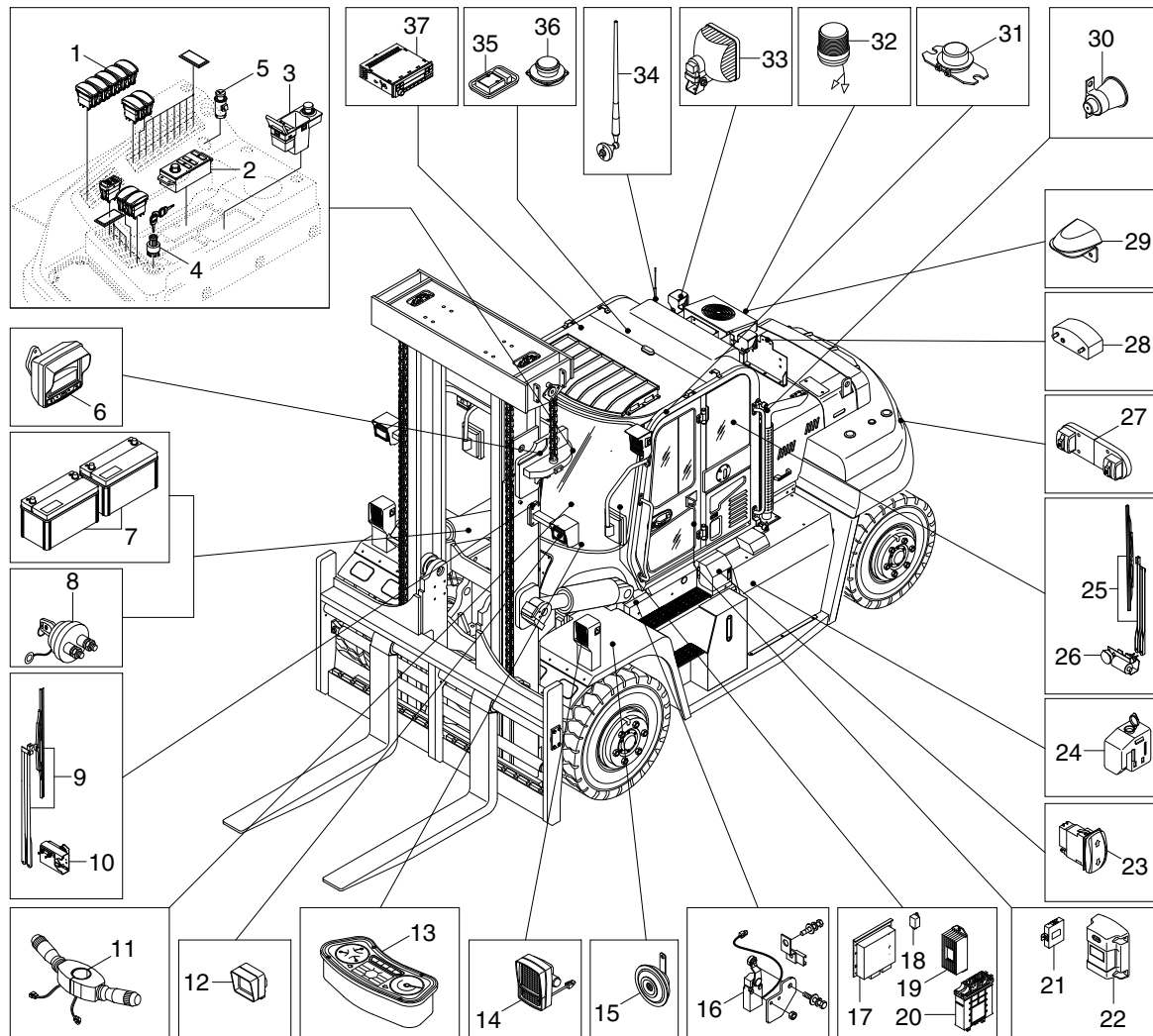

110D9EL02

- |    |                       |    |                       |    |                       |
|----|-----------------------|----|-----------------------|----|-----------------------|
| 1  | Switch panel          | 14 | Head lamp             | 27 | Rear combination lamp |
| 2  | Remote controller     | 15 | Horn                  | 28 | License lamp          |
| 3  | USB & socket assembly | 16 | Tilt switch           | 29 | Rear camera kit       |
| 4  | Start switch          | 17 | MCU                   | 30 | Travel alarm buzzer   |
| 5  | Cigar lighter         | 18 | Int wiper relay       | 31 | Heater relay          |
| 6  | Monitor assembly      | 19 | DC-DC converter       | 32 | Beacon lamp           |
| 7  | Battery               | 20 | TCU                   | 33 | Work lamp assembly    |
| 8  | Master switch         | 21 | Bluetooth handsfree   | 34 | Antenna               |
| 9  | Wiper assembly        | 22 | RMCU                  | 35 | Room lamp             |
| 10 | Wiper motor           | 23 | Cabin tilt switch     | 36 | Speaker assembly      |
| 11 | Multifunction switch  | 24 | Washer reservoir tank | 37 | Radio and USB player  |
| 12 | Front turn lamp       | 25 | Rear wiper assembly   |    |                       |
| 13 | Cluster               | 26 | Rear wiper motor      |    |                       |



# CHARGING CIRCUIT

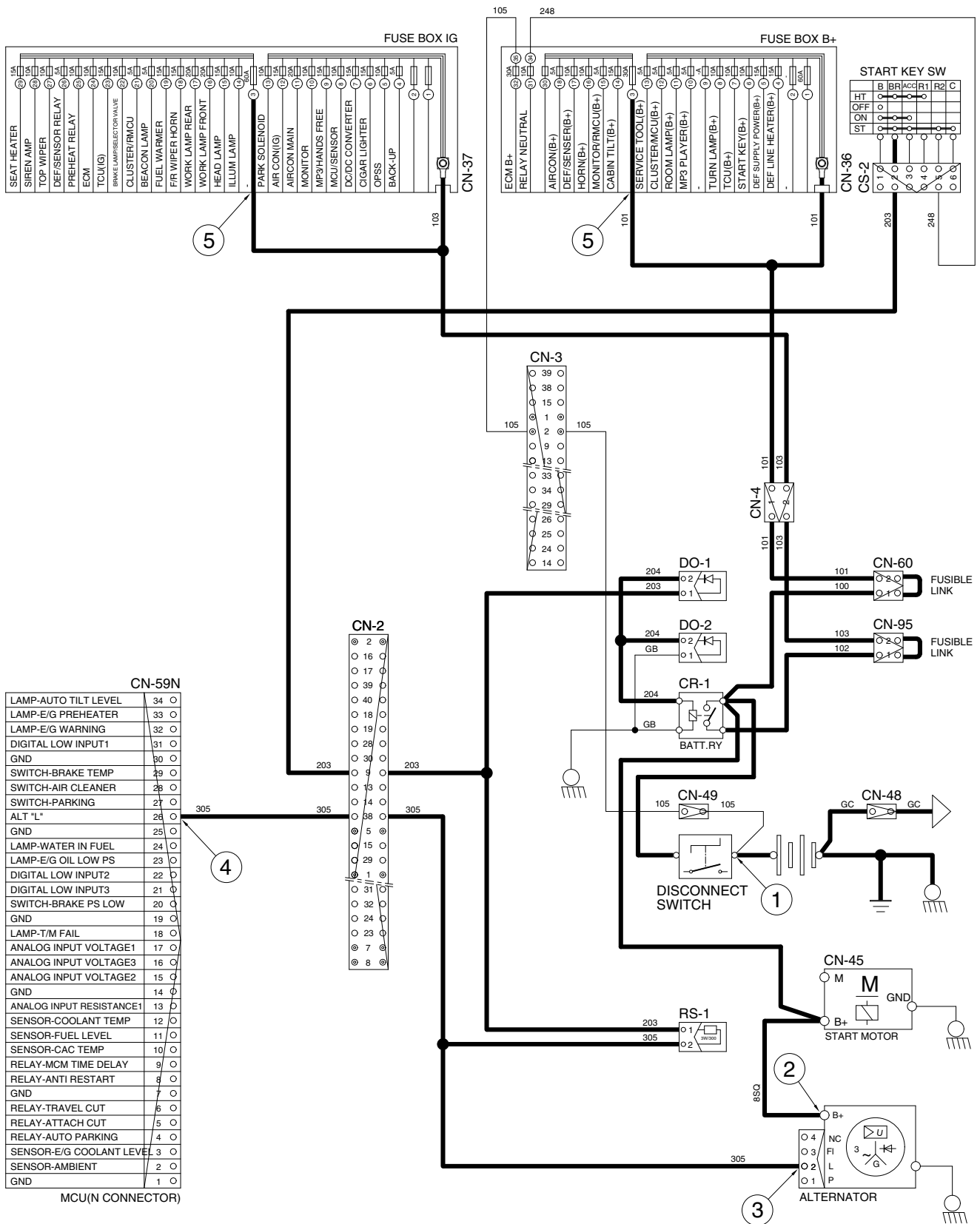

110D9EL07

### 3) WARNING LAMPS

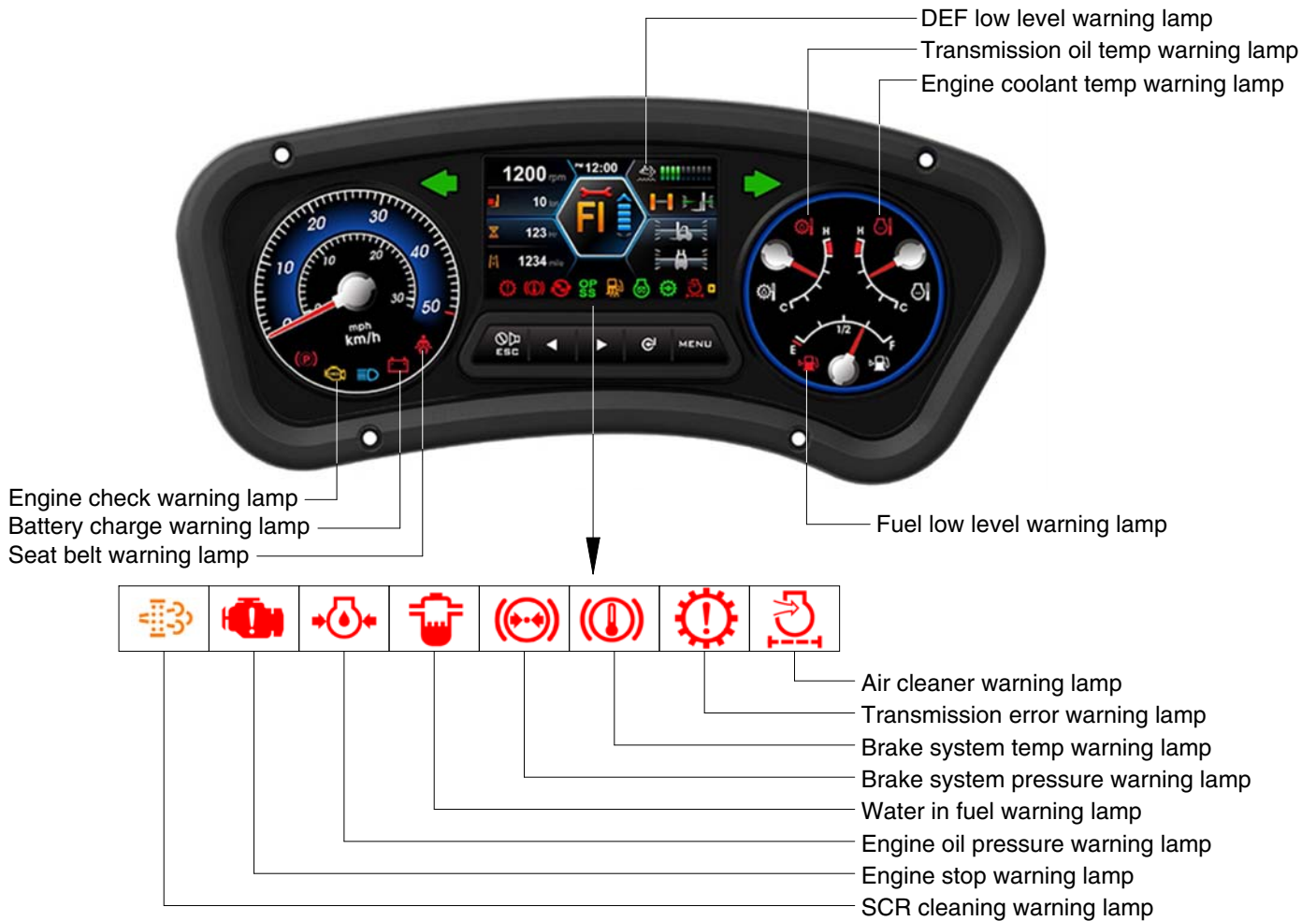

50D9CD02-1

※ When the warning and pilot lamps are illuminated more than display, you can display next lamps by push the button (▶).

#### (1) Engine check lamp



- ① This lamp lights ON during a nonfatal engine system error. The engine can still be run, but the fault should be corrected as soon as possible.



#### (2) Brake fail warning lamp



- ① The lamp lights ON when the oil pressure of service brake drops below the normal range.
- ② When the lamp is ON, stop the engine and check for its cause.

※ Do not operate until the problems are corrected.

## (2) Main menu

No.	Main menu	Sub menu	Description
1	 Equipment <small>50D9CD14K</small>	Model select Tilt setting Rear angle setting Weight sensor setting ESL setting Vehicle max speed limit AEB setting (R) MCU/cluster information	Model select Tilt setting (mast and vehicle angle) Rear angle setting Cross-section, load weight adjust, weight display setting, load indicator buzzer ESL setting Vehicle max speed limit (10~30 km) AEB setting (R)MCU/cluster information
2	 Maintenance <small>50D9CD15K</small>	Current failure history Maintenance management Signal statue User password change RMCU comm	Display failure status (engine, transmission) Replacement, Change interval oils and filters Display information of sensors User password change (5~10 digit) Orbcomm, GPS antenna
3	 Display setting <small>50D9CD16K</small>	LCD adjustment Time setting Unit setting Language setting AS phone number ESL password change Maintenance management	LCD brightness setting Time setting Unit setting (temp, speed, weight, pressure) Language setting (13 languages) Check and change AS phone number ESL password change (5~10 digit) Maintenance information (cycle, elapsed time, change count, alarm info)

## 4. TRANSMISSION MESSAGE DISPLAY

### 1) FUNCTION

The display can be used with the gear selector (DW-3). It indicates speed and driving direction. When driving in the automatic mode, a bar indicator gives additionally also information about the selected driving range; The automatic range is symbolized by arrows above and below the bar indicator. In case of possible errors in the system, a wrench appears on the display, combined with indication of the error number. Also sporadically occurring errors can be indicated.

Transmission message display



50D93ACD33

If it happens error codes, consult with Hyundai service center to repair the fault.

## GROUP 6 ELECTRICAL COMPONENT SPECIFICATION

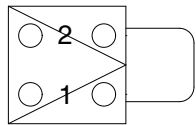
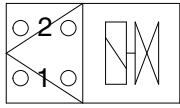
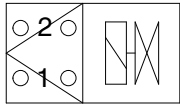
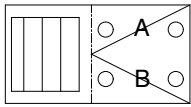
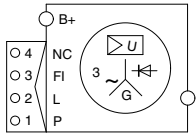
Part name	Symbol	Specifications	Check
Battery		12V × 100Ah (2EA)	※ When checking the battery charging indicator, Green : Normal condition Black : Discharge condition Transparency : Change
Fusible link	 CN-60 CN-95	CN-60 : 24V 27A CN-95 : 24V 45A	※ Check disconnection Normal : 0 Ω (Connect ring terminal and check resistance between terminal 1 and 2)
EPPR valve (Pump, Fan)	 CN-154 CN-155	24V 300A	※ Check resistance About 24 Ω
Solenoid valve (Parking, Attach cut off, Side shift selector, DEF tank heater, DEF dosing module)	 CN-71 CN-131 CN-132 CN-J27 CN-J31	24V 1.2A	※ Check LED lamp. ※ Check resistance About 24 Ω
Heater (Seat, DEF line heater 1, 2, 3)	 CN-170 CN-381 CN-382 CN-383	24V	※ Check resistance Normal : About 200 Ω (for terminal 1-3) 0 Ω (for terminal 2-4)
Alternator	 CN-74	Delco Remy 24SI 24V 70A	※ Check voltage Normal : 24~28V

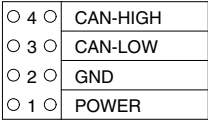
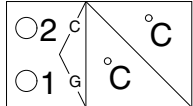
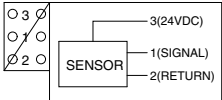
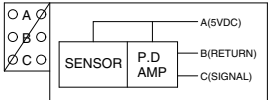
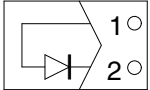
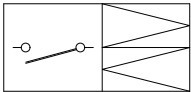
Part name	Symbol	Specifications	Check
G-sensor	 <p>CD-6</p>	24V, 5W	-
Temperature sensor (Ambient, cac)	 <p>CD-76 CD-87</p>	-	-
Load sensor	 <p>CD-50</p>	24V, hall sensor	※ Check voltage 0.5~4.5 VDC (1-2)
Angle sensor	 <p>CD-12</p>	5V, hall sensor	※ Check voltage 0.4~4.5 VDC (B-C)
Diode	 <p>DO-1 DO-2 DO-3 DO-4 DO-5</p>	Diode spec : 1N5406	-
Side shift selector switch	 <p>CS-13</p>	24V	※ Check contact Normal : ∞ Ω

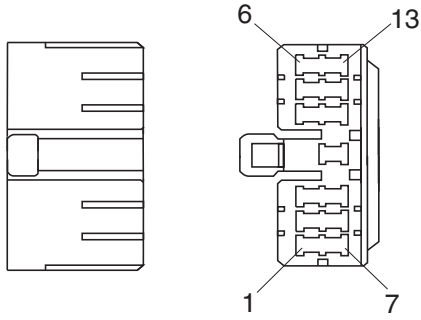
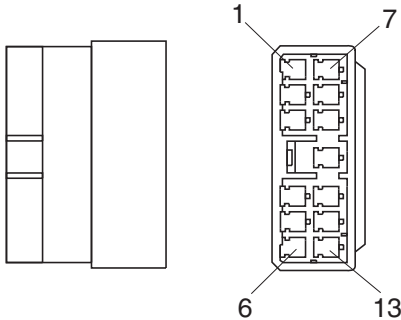
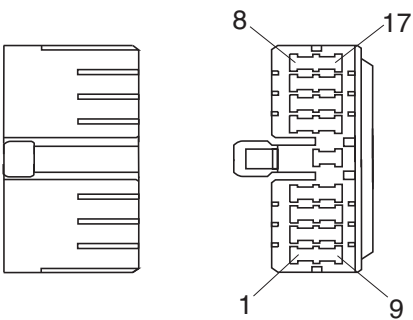
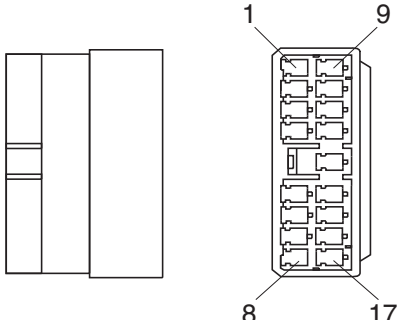
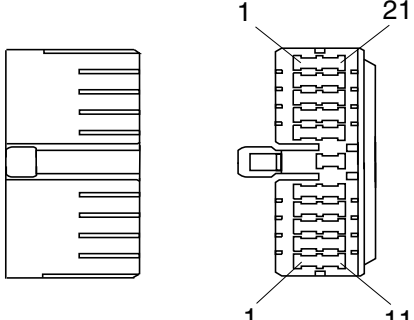
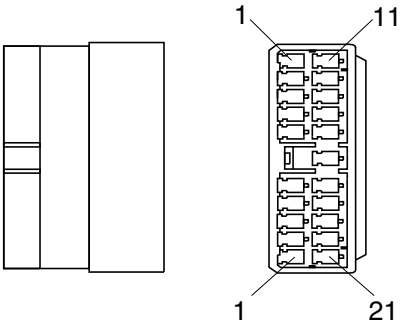
No. of pin	Receptacle connector (Female)	Plug connector (Male)
13	 <p style="text-align: center;">S811-013002</p>	 <p style="text-align: center;">S811-113002</p>
17	 <p style="text-align: center;">S811-017002</p>	 <p style="text-align: center;">S811-117002</p>
21	 <p style="text-align: center;">S811-021002</p>	 <p style="text-align: center;">S811-121002</p>

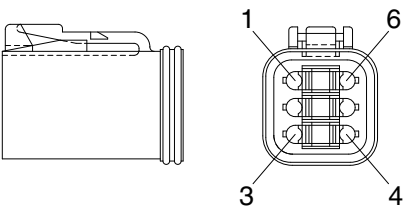
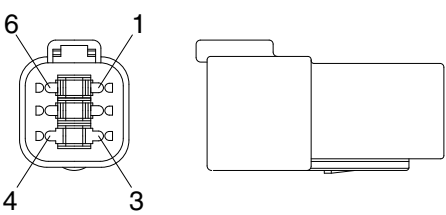
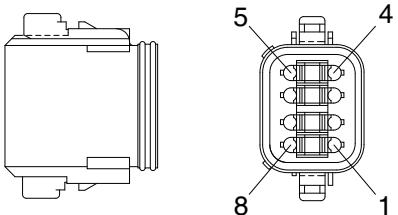
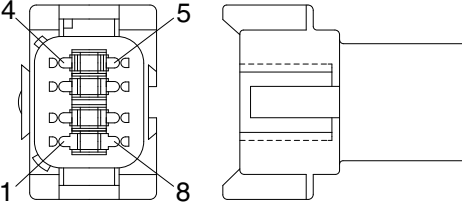
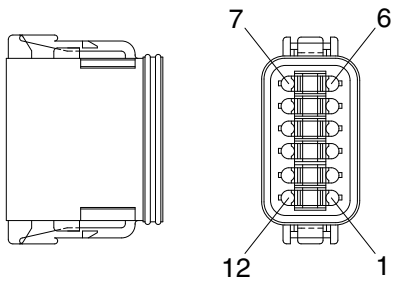
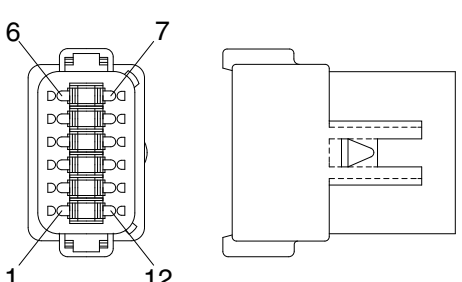
No. of pin	Receptacle connector(Female)	Plug connector(Male)
6	 <p style="text-align: center;">DT06-6S</p>	 <p style="text-align: center;">DT04-6P</p>
8	 <p style="text-align: center;">DT06-8S</p>	 <p style="text-align: center;">DT04-8P</p>
12	 <p style="text-align: center;">DT06-12S</p>	 <p style="text-align: center;">DT04-12P</p>

## 2) CARRIAGE LOAD ROLLER

- (1) Measure the clearance when the center of the carriage upper roller is 100 mm from the top of the inner mast.
- (2) Measure the clearance at upper, middle and lower rollers after loosen the adjust screws from the side rollers. Shift the carriage to one side to bring the roller into contact with the inner mast, and measure the clearance between the roller side face and mast at the closest position on the opposite side to the following value by adjust screw.
  - Standard clearance  $C = 0\sim 0.6$  mm
- (3) Distribute the roller clearance equally to the left and right roller.
- (4) After the adjustment, the carriage should move smoothly along the overall mast length.

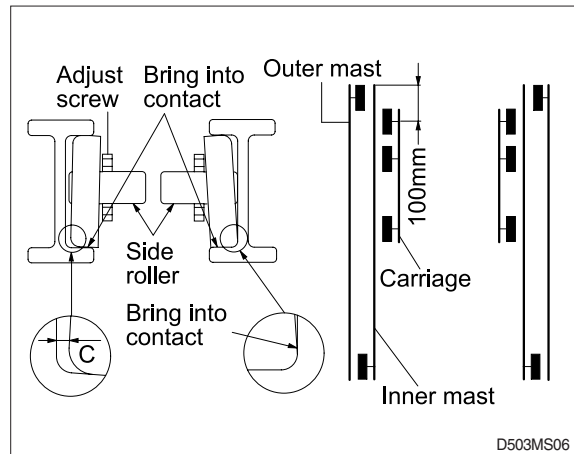

D503MS06

CLICK HERE TO **DOWNLOAD** THE COMPLETE MANUAL

- Thank you very much for reading the preview of the manual.
- You can download the complete manual from: [www.heydownloads.com](http://www.heydownloads.com) by clicking the link below



- Please note: If there is no response to CLICKING the link, please download this PDF first and then click on it.

CLICK HERE TO **DOWNLOAD** THE COMPLETE MANUAL