

SINGLE-SPEED POWERSHIFT TRANSMISSION

TROUBLESHOOTING AND REPAIR

S/H2.00/2.50/3.00/3.20XM

(S/H40/45/50/60/65XM)

[D187, D177];

H2.00/2.50/3.20XM (H45/50/55/60/65XM) [H177]

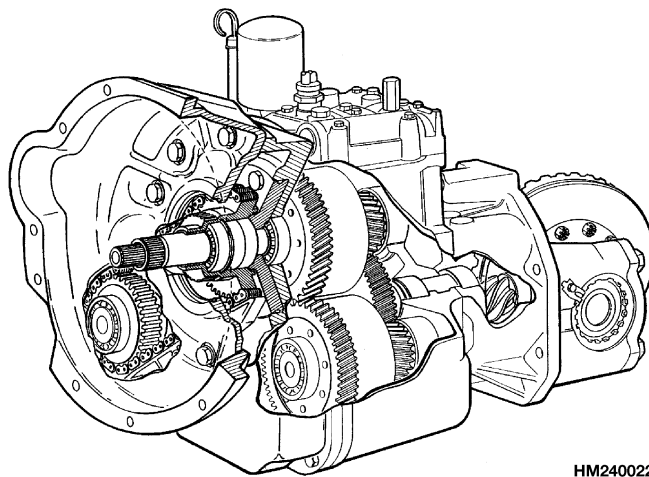

HM240022

HYSTER

CLICK HERE TO **DOWNLOAD** THE COMPLETE MANUAL

- Thank you very much for reading the preview of the manual.
- You can download the complete manual from: www.heydownloads.com by clicking the link below



- Please note: If there is no response to CLICKING the link, please download this PDF first and then click on it.

CLICK HERE TO **DOWNLOAD** THE COMPLETE MANUAL

STEP 2.

If the ball bearing did not stay in the transmission case, remove it from the clutch shaft. Remove the special thrust washer. Remove the snap ring, thrust washers, and thrust needle bearing. Remove the output gear from the clutch assembly. Remove the large snap ring, then remove the pressure plate. For lift truck without Exedy clutch assemblies, remove the friction discs and separator plates. For lift trucks with Exedy clutch assemblies, remove the conical plate, the friction discs and separator plates. See Figure 12.

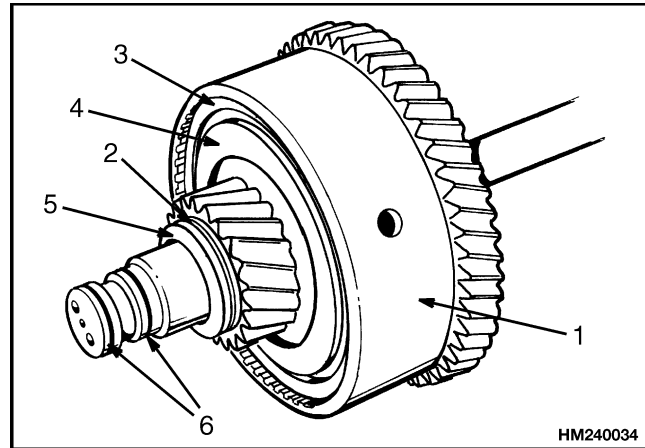

1. OUTPUT GEAR
2. THRUST BEARING ASSEMBLY
3. SNAP RING
4. PRESSURE PLATE
5. SNAP RING
6. SEAL RINGS

STEP 3.

Remove the needle bearings from the shaft. Remove the other set of thrust washers and thrust needle bearing.

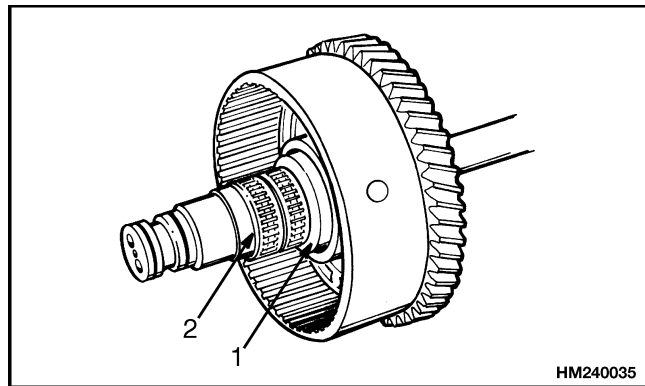

1. THRUST ASSEMBLY
2. NEEDLE BEARINGS

units, tighten the capscrews for the bearing caps to 110 N•m (81 lbf ft).

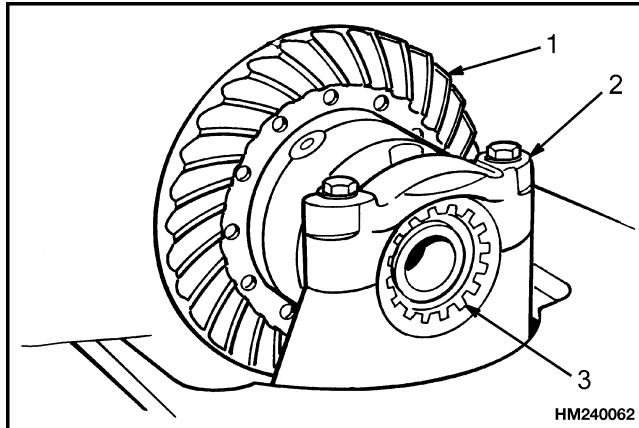

1. RING GEAR 3. ADJUSTMENT NUT
2. BEARING CAP

Figure 27. Bearing Caps and Adjustment Nuts Installation

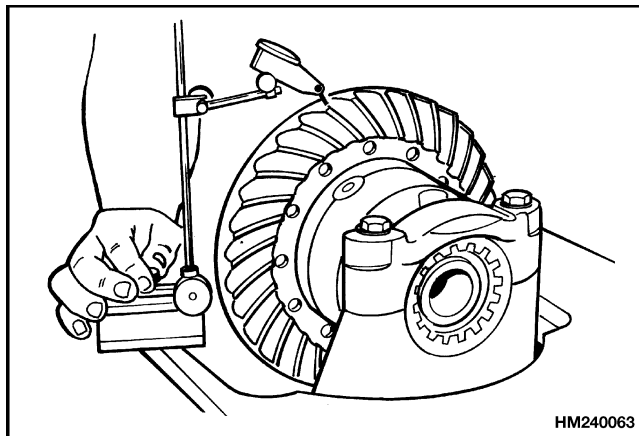

Figure 28. Clearance Check Between Ring Gear and Pinion

- o. Check the pattern on the teeth of the ring gear by applying grease to the teeth. Put a pry bar between the ring gear and the housing to keep the ring gear from turning freely. Turn the pinion shaft. Compare the pattern on the ring gear teeth with the patterns shown in Ring and Pinion Tooth Contact Adjustment. Adjust the gear clearances as necessary. An adjustment of the pinion to move

the contact pattern also normally requires an adjustment of the ring gear clearance as described in Step m.

- p. Install the retainers for the adjustment nuts. Tighten the capscrews for the retainers to 19 N•m (14 lbf ft).

NOTE: If adjustment of the thrust bolt (Figure 29) is required when the differential is installed, turn the thrust bolt clockwise until it contacts the ring gear. Then loosen the thrust bolt counterclockwise 1/6 of a turn. Tighten the lock nut to 68 to 95 N•m (50 to 72 lbf ft).

- q. Install the thrust bolt. See Figure 29. Tighten the thrust bolt until it touches the ring gear. Loosen the bolt until there is 0.25 to 0.38 mm (0.010 to 0.015 in.) clearance between the bolt and the ring gear. Tighten the lock nut to 68 to 95 N•m (50 to 72 lbf ft).

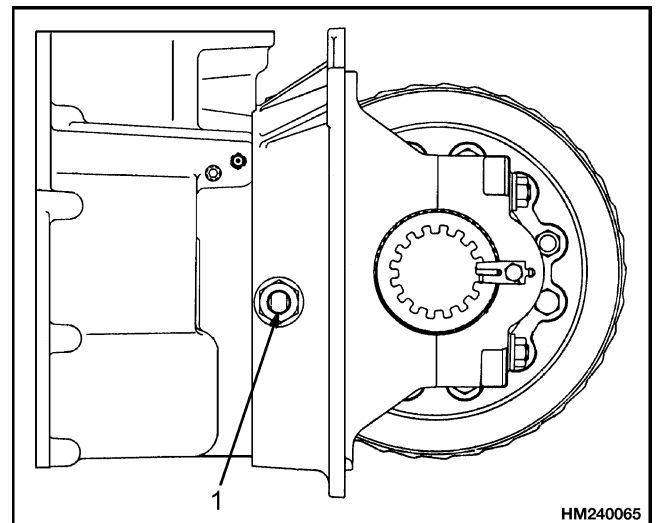

NOTE: H2.00-3.20XM (H40-65XM) SHOWN. S2.00-3.20XM (S40-65XM) SIMILAR.

1. THRUST BOLT

Figure 29. Thrust Bolt Adjustment

Oil Pressure Checks

See Troubleshooting - Pressure Tests for reasons that cause pressures that are not according to the specifications. Test Ports 1 to 6 are shown in Table 4. These test ports are normally used to check the operation of the transmission. Test Ports 5 and 6 can be used for additional troubleshooting of the oil cooler and the modulator. Install the four 0 to 2000 kPa (0 to 300 psi) pressure gauges in the test ports shown in Table 4. None of the relief valves or regulators in this transmission are adjustable. The pressure tests are for troubleshooting. Before checking the oil pressures, do the following:

1. Operate the lift truck until the engine and transmission are at normal operating temperatures. Connect a tachometer to the engine. When the engine is at the normal operating temperature, make sure the engine will operate at the governor speed limit:

Mazda M4-2.0G (Gasoline)	2600 to 2700 rpm
Mazda M4-2.0G (LPG)	2600 to 2700 rpm
GM 2.2L (Gasoline)	2800 to 2900 rpm
GM 2.2L (LPG)	2800 to 2900 rpm
GM 3.0L (Gasoline)	2800 to 2850 rpm
GM 3.0L (LPG)	2800 to 2850 rpm
GM 3.0L (Dual Fuel)	2800 to 2850 rpm
Isuzu C240	2600 to 2700 rpm
Isuzu 4JB1	2100 to 2200 rpm
Isuzu 4JG2	2100 to 2200 rpm

2. Start the engine and tilt the mast backward. Put blocks under the outer mast channels. Tilt the mast forward to raise the wheels from the surface.
3. All oil pressures are checked with the engine operating at 2000 rpm. The operating temperature of the transmission oil is 50 to 65°C (120 to 150°F).

RELIEF VALVE FOR TRANSMISSION PUMP CHECK, TEST PORT 1

Apply the parking brake (direction control lever only). Put the direction control lever in **NEUTRAL**.

For older lift truck models, if the pressure from the transmission is not 965 to 1310 kPa (140 to 190 psi), see Troubleshooting. For newer lift truck models, if the pressure from the transmission is not 1103 to 1310 kPa (160 to 190 psi), see Troubleshooting.

CLUTCH PRESSURE CHECK, TEST PORTS 2 AND 3

1. Put the transmission in **FORWARD**. For older lift truck models, if the pressure is not 724 to 860 kPa (105 to 125 psi), see Troubleshooting. For newer lift truck models, if the pressure is not 862 to 1000 kPa (125 to 145 psi), see Troubleshooting.
2. Run the engine at 2000 rpm and push the inching pedal down. The clutch pressure must decrease to approximately zero pressure when the inching pedal is fully pushed down.
3. Put the transmission in **REVERSE**. For older lift truck models, if the pressure is not 724 to 860 kPa (105 to 125 psi), see Troubleshooting. For newer lift truck models, if the pressure is not 862 to 1000 kPa (125 to 145 psi), see Troubleshooting.
4. Run the engine at 2000 rpm and push the inching pedal down. The clutch pressure must decrease to approximately zero pressure when the inching pedal is fully pushed down.
5. The difference in the Input (forward) and Counter (reverse) clutch pressures cannot be more than 70 kPa (10 psi). A larger difference in clutch pressures indicates a problem.

TORQUE CONVERTER REGULATOR CHECK, TEST PORT 4

Apply the parking brake. Run the engine at 2000 rpm and push the inching pedal fully down. For older models, if the pressure is not 724 to 860 kPa (105 to 125 psi), see Troubleshooting. For newer models, if the pressure is not 724 to 827 kPa (105 to 120 psi), see Troubleshooting.







*Legend for Figure 3***A. DUAL GEAR SET HYDRAULIC PUMP**

1. VALVE HOUSING
2. O-RING
3. END HOUSING
4. HOUSING SEAL
5. BACKUP SEAL
6. PRESSURE PLATE
7. DRIVEN GEAR

B. SINGLE GEAR SET HYDRAULIC PUMP

8. DRIVE GEAR
9. GEAR HOUSING
10. FLANGE END HOUSING
11. SEAL
12. SNAP RING
13. ISOLATOR
14. PRESSURE PLATE SEAL

Table 1. Instrument Cluster, Internal Combustion (Continued)

Item No.	Item	Function
2	Coolant Temperature Gauge 	 CAUTION Do not continue to operate the lift truck when the gauge indicates that the engine is too hot (needle in the red zone). This gauge indicates engine coolant temperature when the key is in the ON position. During normal operation, the gauge needle will be in the green area. The sending unit for the coolant temperature gauge is in the cylinder head. If the temperature gauge does not work, check the wiring or replace the sending unit or gauge. To check the wiring, see the service manual section for Diagrams .
3	Hourmeter	The hourmeter operates when the key is in the ON position. Periodic Maintenance recommendations are based on these hours.
4	Left-Hand Turn Indicator (Optional) 	The light is on when the turn indicator lever is in the left turn position.
5	Warning Light, Alternator 	 CAUTION Do not continue to operate the lift truck if the red light is ON at engine speeds above idle. The light will be ON when the key is in the ON position and the engine is not running and must go OFF when the engine is running. If the light does not function correctly, check the alternator as described in the section for the Electrical System 2200 SRM 560. To check the wiring, see the service manual section for Diagrams .
6	Warning Light, Transmission Oil Temperature 	 CAUTION Do not continue to operate the lift truck if the red light is ON. The red light is ON when the key is in the START position and must go OFF when the engine is running. The sending unit for the temperature light is at the bottom of the transmission housing, on the front side. If the temperature light does not work, check the wiring or replace the sending unit or light. To check the wiring, see the service manual section for Diagrams .

to the connector. After removing screws that fasten front cover, carefully disconnect connector. It can be necessary to disconnect key switch wires (Step 4) and two-wire connector for enough clearance to disconnect 18-pin connector. Remove two screws that fasten LED assembly to housing. Install replacement LED assembly. Carefully connect all connectors and wires. Install front steering column cover with display panel assembly attached. Install LED gasket over LED indicators.

8. If necessary, install new O-ring gasket. Carefully install O-ring gasket in groove of top cover. Carefully install top cover assembly over LED indicators and assembly housing without damaging either LED gasket or O-ring gasket. Make

sure O-ring gasket is still correctly aligned with cover and housing before installing screws. Install eight screws that fasten top cover to panel housing and tighten them in a cross pattern.

ENHANCED DISPLAY PANEL PARTS, REPLACE

The only replaceable parts of the enhanced display panel are the O-ring seal, key switch, wires to the key switch, and the housing that fastens to the steering column. All other parts of the panel must be replaced as a single unit. See Display Panel Assembly, Replace and Figure 3.

Curtis 1215 Display Panel Replacement

REMOVE

The Curtis 1215 Display Panel is located in the front cover over the battery compartment. The display panel cannot be repaired and must be replaced if it is faulty.

1. Move lift truck to a safe, level area. Turn key switch to **OFF** and remove key. Put a **DO NOT OPERATE** tag on the multifunction control handle. Put blocks under drive wheels to keep lift truck from moving. Refer to How to Put Lift Truck on Blocks in the section **Periodic Maintenance**.



WARNING

Disconnect battery and separate connector before opening compartment cover or inspecting or repairing electrical system. If a tool causes a short circuit, the high-current flow from the battery can cause an injury or parts damage.

2. Disconnect and separate battery connector.
3. Remove hydraulic tank dipstick.
4. Remove socket head capscrews retaining battery compartment cover. Remove battery compartment cover.
5. Disconnect two plugs X-4 and X-6 from rear of display assembly.
6. Remove two nuts and brackets that fasten display assembly to instrument panel. See Figure 10. Remove display assembly.

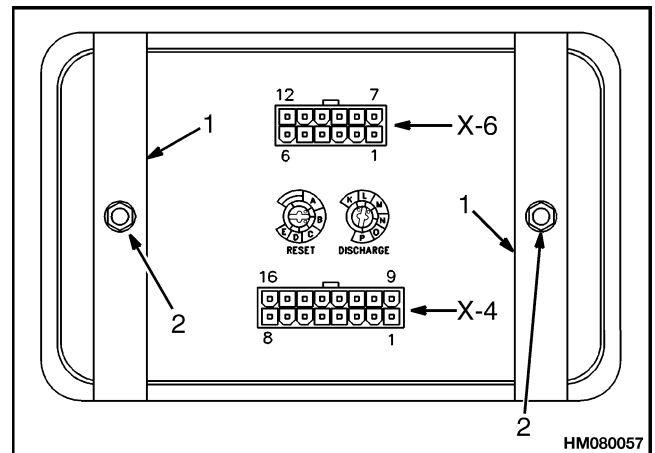

1. MOUNT BRACKET
2. MOUNT NUT

Figure 10. Curtis 1215 Mount

INSTALL

1. Adjust pots on rear of dash display assembly.
2. Connect two plugs X-4 and X-6 to rear of dash display.
3. Position display assembly in instrument panel. Install nuts and brackets to rear of display to fasten display assembly to instrument panel.
4. Install battery cover.
5. Reinstall hydraulic tank dipstick.
6. Remove blocks from under drive wheels. Remove **DO NOT OPERATE** tag. Connect battery and install key.

- 10. Warning LED, Motor Temperature Over Limit.** The traction motor and the hydraulic pump motor have thermal switches inside the motors. When the temperature increases to the limit, the thermal switch closes and the warning LED on the display panel illuminates. The LED indicator for the traction motor indicator or for the hydraulic motor will show which motor has the problem. The maximum travel speed will also be decreased to speed limit 1.
- 11. Warning LED, Service Interval.** When it is time for periodic maintenance, the warning LED, service interval indicator will be illuminated and a status code -99 will be indicated. The register in the controller card must be reset by the service person before this warning LED will go **OFF**. The warning LED will also be illuminated when a problem occurs.
- 12. LED Indicator, Hourmeter.** This LED will illuminate with another indicator when hours of operation are shown on the digital display. Refer to the previous **Digital Display** for the complete description of operation.
- 13. Push Button, Status Codes.** With the key in the **OFF** position, this push button will cause the status codes for the problems to be shown on the digital display. When the button is held down for 1 or 2 seconds, the LED indicator for the traction motor will illuminate. The status codes in memory for the detected problems will be displayed, starting with the most recent problem. The system will go through 16 traction codes, then automatically go through 16 pump motor codes. If the button is pushed again, the display will start from the beginning again. The hourmeter time and the battery charge at the time of the problem will not be shown. A handset or a personal computer (PC) must be used to show this additional information. A handset or a PC must be used to clear the status code from the register. For the correct procedures for using the handset or PC, see **EV-100ZX™ SCR Motor Controller** 2200 SRM 557 or **EV-T100™ Transistor Motor Controller** 2200 SRM 581.

If the button is pushed briefly, released, then held down for 1 or 2 seconds, the LED indicator for the hydraulic motor will illuminate. The status codes in memory for the detected problems will be displayed, starting with the most recent problem. If the button is pushed twice to start the sequence again, the display will start from

the beginning. The hourmeter time at the time of the problem will not be shown. A handset or a PC must be used to show this additional information. A handset or a PC must be used to clear the status code from the register. For the correct procedures for using the handset or PC, see **EV-100ZX™ SCR Motor Controller** 2200 SRM 557 or **EV-T100™ Transistor Motor Controller** 2200 SRM 581.

- 14. Push Button, Set Lift Truck Performance.** The lift truck can be set to any one of four performance levels by the operator. If the customer does not want this function available to the operator, a service person can set all four levels to the same setting. Each time the operator pushes the yellow button, the performance level will increase by one step. After the maximum (rabbit) level, the performance levels will begin at the lowest (turtle) level again. The four performance levels set by the manufacturer are:
- Lowest performance for handling fragile loads and lowest rate of consumption of battery energy.
 - Medium travel and lift speed and some increase in consumption of battery energy.
 - Higher performance with higher consumption of battery energy.
 - Highest level of lift truck performance with maximum consumption of battery energy.

A service person can adjust the performance settings with either a PC or the handset (functions 48 through 62). For the correct procedures for using the handset or PC, see **EV-100ZX™ SCR Motor Controller** 2200 SRM 557 or **EV-T100™ Transistor Motor Controller** 2200 SRM 581.

The four performance levels can be set to any level up to the maximum limits. Two or more adjacent performance levels can be set to the same limits. The performance levels must be set at the same or in ascending order (from turtle to rabbit). The register interlocks will not permit a higher performance level setting toward the turtle than the adjacent registers toward the rabbit. The lower performance level is always to the left (turtle).

- 15. LED Indicators, Performance Level.** These four LEDs show which performance level has been selected. The LEDs illuminate in sequence from low performance (turtle) to maximum performance (rabbit).

General

This section has the descriptions and service procedures for the electrical systems used on the Mazda M4-2.0G and M4-2.2G gasoline or LPG engines. This section includes the starting, ignition, and charging systems.

Description

STARTING SYSTEM

The starting system includes the starter, battery, key switch, and neutral start switch. See Figure 1. The starter solenoid is energized when current flows through the key switch, neutral start switch, and solenoid. The solenoid magnetically pushes the clutch out to engage the engine flywheel teeth. The solenoid also closes contacts to energize the starter motor. These operations occur at approximately the same time. The motor torque is applied just as the teeth engage. The key switch must be in the **START** position. The neutral start switch must also be in the **ON** position to energize the starter. The neutral start switch is in the **ON** position when the transmission is in **NEUTRAL**.

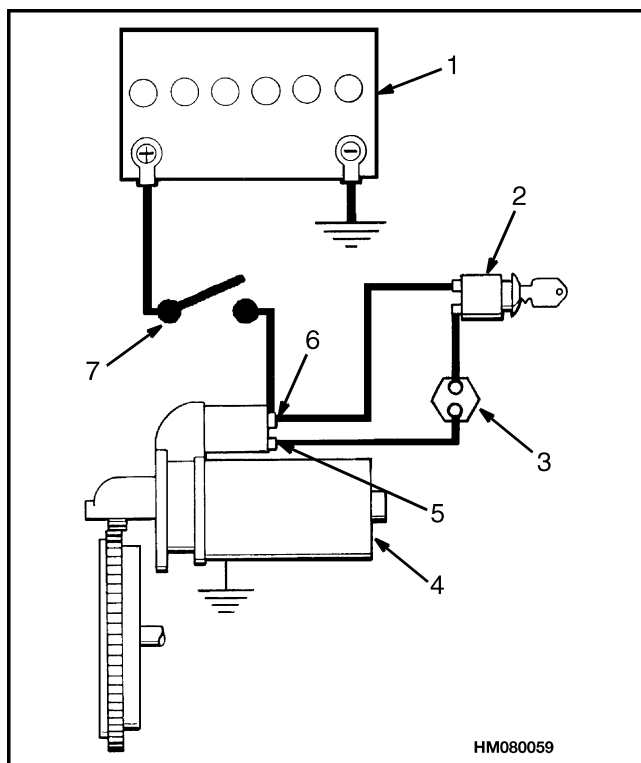

Figure 1. Starting Circuit

Legend for Figure 1

- | | |
|-------------------------|---------------------------------|
| 1. BATTERY | 5. S TERMINAL |
| 2. KEY SWITCH | 6. BATTERY |
| 3. NEUTRAL START SWITCH | 7. DISCONNECT SWITCH (EEC ONLY) |
| 4. STARTER | |

IGNITION SYSTEM

The ignition system generates a spark at each spark plug to start combustion in each cylinder. The ignition system has the following main parts: battery, key switch, coil, distributor, spark plugs, and wires. See Figure 2.

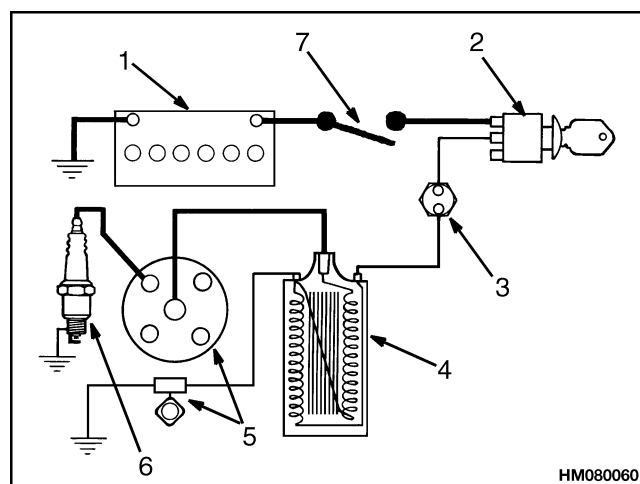

- | | |
|-------------------------|---------------------------------|
| 1. BATTERY | 5. DISTRIBUTOR |
| 2. KEY SWITCH | 6. SPARK PLUG |
| 3. NEUTRAL START SWITCH | 7. DISCONNECT SWITCH (EEC ONLY) |
| 4. COIL | |

Figure 2. Ignition Circuit

If the starter is operating, current flows from the battery through the key switch and the neutral start switch to energize the starter solenoid. Current also flows through the key switch, coil primary, and distributor. The distributor opens and closes the coil primary circuit as the starter rotates the engine crankshaft. The opening and closing of the circuit causes the primary current and magnetic field in the coil to change. The changing magnetic field generates

BRUSHES AND BEARINGS, CHECK

1. Check each brush for minimum brush length on shortest side of 7 mm (0.3 in.).
2. Check brush springs. Install new spring if spring is broken, rusty, or distorted. If brushes have changed color from heat or are weak, replace them.
3. Check brush holder for cracks or damage.
4. Check armature bearings for smooth operation. Bearings must not be loose or have seal leaks.

VOLTAGE REGULATOR, CHECK

Use a voltage regulator test device. Follow the directions that come with the test device. Do not use an ohmmeter.

If voltage regulator is damaged, replace voltage regulator.

Troubleshooting

PROBLEM	POSSIBLE CAUSE	PROCEDURE OR ACTION
Starter does not run or has slow speed.	Battery is not fully charged or is damaged.	Charge battery or install new battery.
	Connections at battery or starter are loose or have corrosion.	Clean electrical terminals and connectors.
	Key switch is damaged.	Install new key switch.
	Solenoid coil or switch contacts are damaged.	Install new solenoid.
	Brush springs in starter are damaged.	Install new brush springs.
	Brush leads are broken or have a short circuit.	Check and repair brush leads.
	Commutator in starter is dirty or worn.	Clean and repair commutator.
	Armature winding in starter is damaged.	Install new armature winding.
	Field windings in starter are damaged.	Install new field winding.
	Worn or damaged starter gears.	Repair starter.
Bearings in starter are worn or damaged.	Install new bearings.	

TROUBLESHOOTING

GENERAL

The following troubleshooting charts are designed to give an efficient method of fault analysis on the MSTS.

WARNING

This troubleshooting requires the operation of the engine for some of the tests. Make sure the tests are done carefully to prevent injury:

- Put the lift truck on a level surface. Lower the carriage and forks and apply the parking brake. Make sure the lift truck can not move and cause an injury during the tests. Put blocks in front and back of the drive tires to prevent movement of the lift truck.
- The fuel system and the engine must operate correctly. Any problems or leaks in the fuel system or the engine must be repaired before doing troubleshooting on the MSTS.
- The fan and the drive belts can remove fingers or cause other injuries. Be careful that your hands and tools do not touch the moving fan or the drive belts.
- The engine exhaust and other parts of the engine are hot. Do not touch a hot surface and cause a burn.

CAUTION

Electronic equipment can be damaged if troubleshooting and repairs are not done correctly. The following CAUTIONS must be followed when doing troubleshooting or repairs on an engine with MSTS:

- Always disconnect the battery negative cable before disconnecting and removing any parts of ignition system.
- Never disconnect the battery from any equipment when the engine is running.
- If the battery must be charged with a battery charger, ALWAYS disconnect the battery from the electrical system.
- Make sure that all electrical connections are clean and have good electrical contact.

- Never connect or disconnect the wiring harness at the MSTS module when the key switch is “ON”.
- Always disconnect the battery and the MSTS module connectors if electric arc welding must be done on the vehicle.
- Make sure that any water or steam is not sent toward the MSTS module or its sensors if the engine compartment is cleaned with steam. The heat and steam can damage the electronic components and cause corrosion in the electrical connections.
- Use only the tools and test equipment described in “TOOLS AND TEST EQUIPMENT” to prevent damage to good components and to obtain correct test results.
- All voltage measurements must be done with a digital voltmeter with a rating of 10 megohm input impedance.
- When a test light is used in troubleshooting, the test light must have less than 0.3 amps (300 milliamps) of maximum current flow. A test for a correct test light is shown in FIGURE 10.

TOOLS AND TEST EQUIPMENT

The following tools are necessary for troubleshooting the MSTS:

- Ohmmeter
- Digital voltmeter. The voltmeter must have a minimum input impedance of 10–megohms. (A digital voltmeter and ohmmeter are normally included in a multi–meter test instrument.)
- Tachometer with inductive trigger signal sensor.
- Test light that has a low current draw as described in FIGURE 10.
- Vacuum pump with a gauge. This vacuum pump is held and operated with the hand. The gauge must be able to indicate a gauge pressure (vacuum) of 34 kPa [20 inches of mercury (20” Hg)]. (See the PRESSURE CONVERSION CHART at the end of this section.)

5. If any tests described in steps 2, 3, or 4 do not work as indicated, check the wiring harness for a short-circuit or an open circuit. If the wiring harness is good, replace the ignition module.

6. When the tests are complete, connect the system for normal operation.

Ignition Module Replacement

1. Remove the distributor cap and rotor.
2. Remove the two screws that hold the ignition module in the distributor.
3. Lift the ignition module and disconnect the connections. Make a note of the connections so that they can be correctly connected again. Remove the ignition module from the distributor.

NOTE: Do not remove the silicon grease from the ignition module or the distributor if the same ignition module will be installed again. If a new ignition module is installed, a small container of silicon grease is in the package. Clean the old silicon grease and apply a new layer of silicon grease to both the ignition module and the distributor housing. This silicon grease is necessary for cooling the ignition module.

4. Connect the connectors in the distributor to the ignition module. Make sure the connectors are the same as when they were removed.
5. Install the ignition module in the distributor.
6. Install the two screws that fasten the ignition module in the distributor.
7. Install the distributor cap and rotor.

SENSING COIL

Test For A Fault

1. Disconnect the battery negative cable.

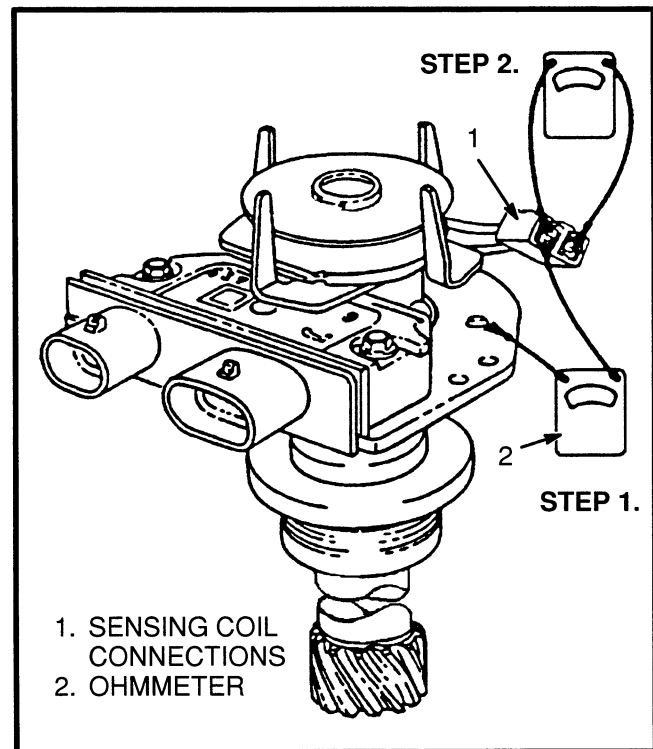

FIGURE 21. TEST THE SENSING COIL

2. Remove the distributor cap. Disconnect the connection from the sensing coil to the ignition module.
3. Check the resistance of the sensing coil with an ohmmeter. Connect ohmmeter to the sensing coil connections as shown in step 1 of FIGURE 21. Check the resistance between both connections and ground. The ohmmeter will indicate infinity for both connections, if the sensing coil is good.
4. Connect ohmmeter across both sensing coil connections as shown in step 2 of FIGURE 21. If the ohmmeter does not indicate 500 to 1500 ohms, replace the sensing coil. Check the wires for a loose connection.

Sensing Coil Replacement

Remove and disassemble the distributor as described in the repairs for the DISTRIBUTOR.

IGNITION COIL

Test For A Fault

1. Disconnect the battery negative (ground) cable.
2. Disconnect the high voltage wire.
3. Disconnect the connectors at the ignition coil.
4. Set the ohmmeter on one of the higher scales. Connect the ohmmeter as shown in step 1 of FIGURE 22. If the

Legend for Figure 4

A. DELCO

- 1. INSULATOR
- 2. PLUG AND BEARING
- 3. BEARING SEAL
- 4. BOLT
- 5. HOUSING
- 6. VOLTAGE REGULATOR
- 7. LOCKWASHER
- 8. BRUSH AND HOLDER
- 9. BRUSH SPRING
- 10. WASHER
- 11. ROTOR
- 12. STATOR
- 13. DIODES

B. MOTOROLA

- 14. NUT
- 15. SCREW
- 16. DIODE BRIDGE
- 17. CAPACITOR
- 18. BEARING
- 19. SLIP RINGS
- 20. TERMINAL
- 21. PULLEY
- 22. FAN
- 23. RETAINER
- 24. SPACER
- 25. SHIELD
- 26. GASKET

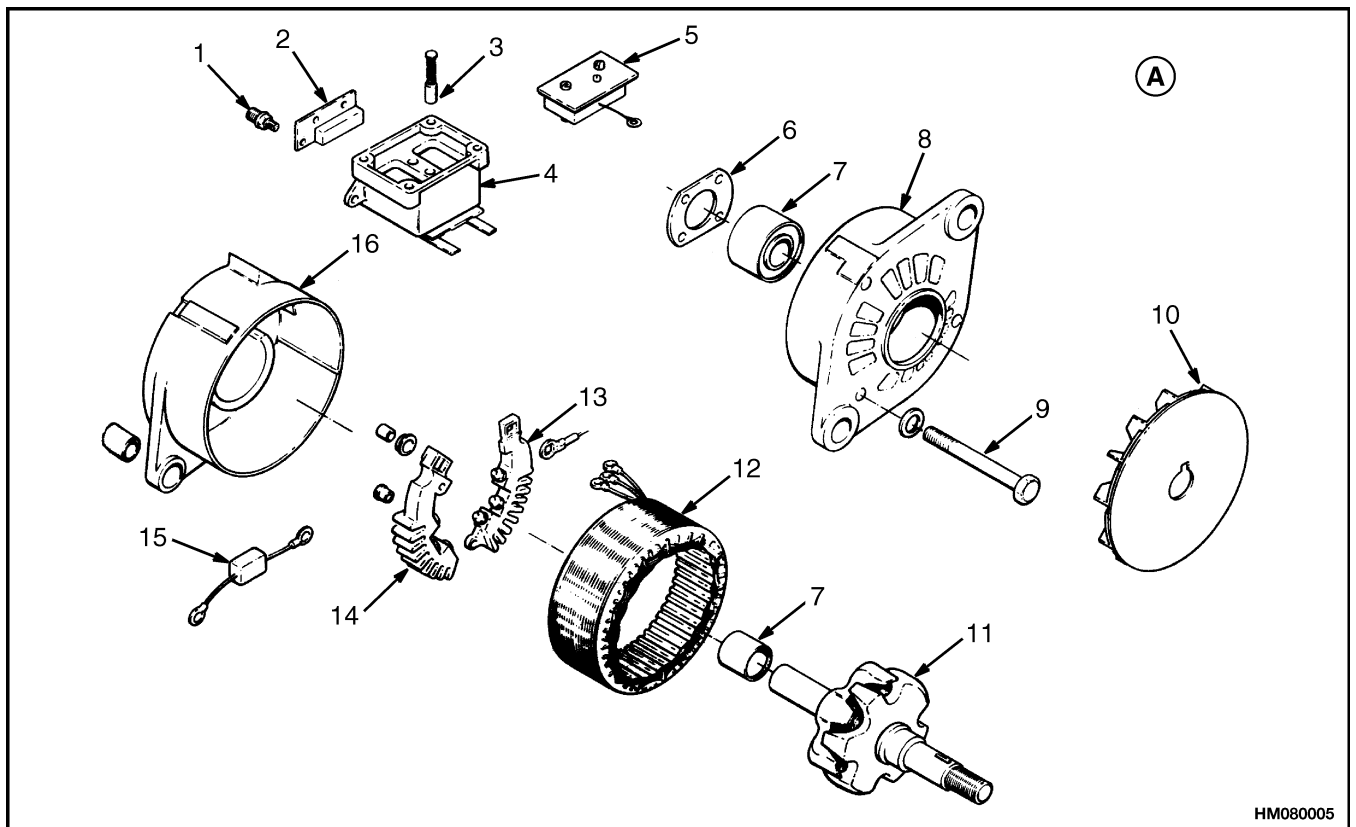

HM080005

A. LEECE-NEVILLE

- 1. TERMINAL
- 2. DIODE SET
- 3. BRUSH AND SPRING
- 4. BRUSH HOLDER
- 5. VOLTAGE REGULATOR
- 6. BEARING RETAINER
- 7. BEARING
- 8. FRONT HOUSING

- 9. BOLT
- 10. FAN
- 11. ROTOR
- 12. STATOR
- 13. NEGATIVE DIODE BRIDGE
- 14. POSITIVE DIODE BRIDGE
- 15. FILTER CAPACITOR
- 16. REAR HOUSING

Figure 5. Type A Alternator; Exploded View

SAFETY PRECAUTIONS

MAINTENANCE AND REPAIR

- When lifting parts or assemblies, make sure all slings, chains, or cables are correctly fastened, and that the load being lifted is balanced. Make sure the crane, cables, and chains have the capacity to support the weight of the load.
- Do not lift heavy parts by hand, use a lifting mechanism.
- Wear safety glasses.
- **DISCONNECT THE BATTERY CONNECTOR** before doing any maintenance or repair on electric lift trucks. Disconnect the battery ground cable on internal combustion lift trucks.
- Always use correct blocks to prevent the unit from rolling or falling. See **HOW TO PUT THE LIFT TRUCK ON BLOCKS** in the **Operating Manual** or the **Periodic Maintenance** section.
- Keep the unit clean and the working area clean and orderly.
- Use the correct tools for the job.
- Keep the tools clean and in good condition.
- Always use **HYSTER APPROVED** parts when making repairs. Replacement parts must meet or exceed the specifications of the original equipment manufacturer.
- Make sure all nuts, bolts, snap rings, and other fastening devices are removed before using force to remove parts.
- Always fasten a **DO NOT OPERATE** tag to the controls of the unit when making repairs, or if the unit needs repairs.
- Be sure to follow the **WARNING** and **CAUTION** notes in the instructions.
- Gasoline, Liquid Petroleum Gas (LPG), Compressed Natural Gas (CNG), and Diesel fuel are flammable. Be sure to follow the necessary safety precautions when handling these fuels and when working on these fuel systems.
- Batteries generate flammable gas when they are being charged. Keep fire and sparks away from the area. Make sure the area is well ventilated.

NOTE: The following symbols and words indicate safety information in this manual:



WARNING

Indicates a condition that can cause immediate death or injury!



CAUTION

Indicates a condition that can cause property damage!

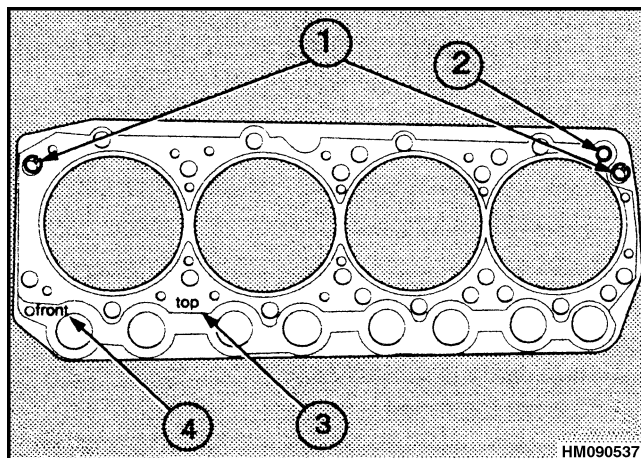

1. DOWEL PINS
2. RUBBER GROMMET
3. TOP GASKET STAMP
4. FRONT GASKET STAMP

Figure 19. Cylinder Head Bottom Face

3. Make sure the rubber grommet is installed in the cylinder head.
4. Put the cylinder head gasket in position on the cylinder block. The cylinder head gasket is marked top and front. Do not use any sealant on the cylinder head gasket.
5. Install the cylinder head on the cylinder block. Make sure the parts are in alignment.
6. Install all of the capscrews and tighten them with your fingers.
7. Gradually and evenly tighten the capscrews to 70 N•m (52 lbf ft) in the sequence shown in Figure 20.
8. Gradually and evenly tighten the capscrews to 100 N•m (74 lbf ft) in the sequence shown in Figure 20. Repeat the sequence to make sure all of the capscrews are correctly tightened.
9. Install the push rods into the same sockets of the tappets from which they were removed.
10. Install the rocker assembly. See Rocker Assembly, Install.
11. Adjust the valve clearances. See Valve Clearance, Adjust.

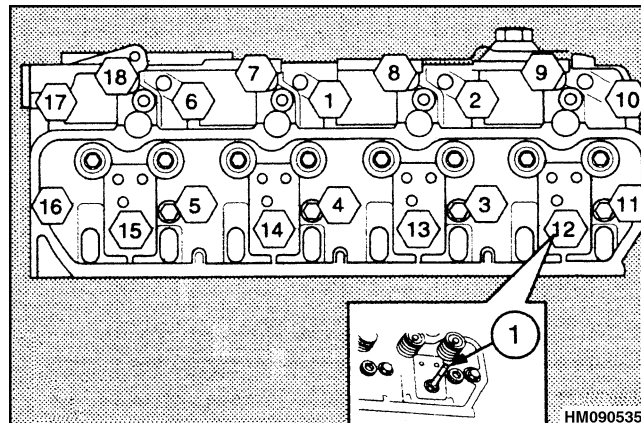

1. CYLINDER HEAD CAPSCREW

Figure 20. Cylinder Head Tightening Sequence

12. Install the valve cover. See Valve Cover, Install.
 13. Connect the sender for the coolant temperature.
 14. Install the coolant hose between the thermostat housing and the coolant pump.
 15. Install the glow plugs as described in the section for glow plugs. See Glow Plugs, Install.
 16. Install the fuel injectors as described in the section for fuel injectors. See Fuel Injectors, Install.
 17. Install the fuel return line between the fuel filter and the fuel injector returns.
 18. Install the exhaust manifold and gasket. To hold the exhaust manifold and gasket in alignment, use two guide studs as shown in Figure 15.
 19. Install the capscrews to fasten the exhaust manifold to the cylinder head.
- NOTE:** The threaded part of the exhaust manifold capscrews has a three-lobe shape.
20. Remove the two guide studs and install the correct capscrews. Tighten the inner capscrews first and then the outer capscrews. Tighten the capscrews evenly to a final torque of 18 N•m (159 lbf in).

2. Install the wear sleeve according to the manufacturer's instructions supplied with the sleeve. Make sure the sleeve is installed to a depth of 12.0 mm (0.47 in.). See Figure 52.

 **CAUTION**

Failure to remove the flange from the sleeve after installation will damage the sleeve, the cylinder block, and the oil seal.

3. After the wear sleeve is installed, break off the flange from the sleeve. It is scored for easy removal.

Install

1. Make sure all oil passages are clean.
2. Make sure all bearings and bearing caps are clean.
3. Install the upper bearing halves into their positions in the connecting rods and the housings for the main bearings. Make sure the position tags of the bearings fit into their position slots. Lubricate the bearings with engine oil.
4. Install the crankshaft in position on the main bearings.
5. Lubricate the half-thrust washers with engine oil.
6. Slide the half-thrust washers into position in the engine block, one on each side of the rear main bearing. Make sure the side of the thrust washer with the groove is toward the crankshaft web.
7. Make sure the position of the location slots for the main bearing halves are correct as shown in Figure 50.
8. Lubricate the bearing with engine oil.
9. Install the main bearing caps. Make sure the main bearing caps are installed according to their position numbers shown on the cap. See Figure 51.
10. Apply a small amount of silicon adhesive to the corners of the cylinder block for the rear main bearing cap. See Figure 53.
11. Make sure the capscrews are in good condition. Install the capscrews into the main bearing cap.

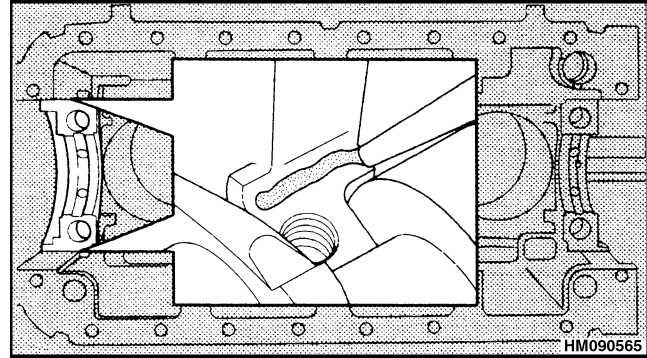

Figure 53. Application of Silicon Sealant to Cylinder Block for Rear Main Bearing Cap

12. Before the front and rear bearing caps are fully tightened, use a straight edge to make sure the front and rear main bearing is aligned with the face of the cylinder block. See Figure 54.

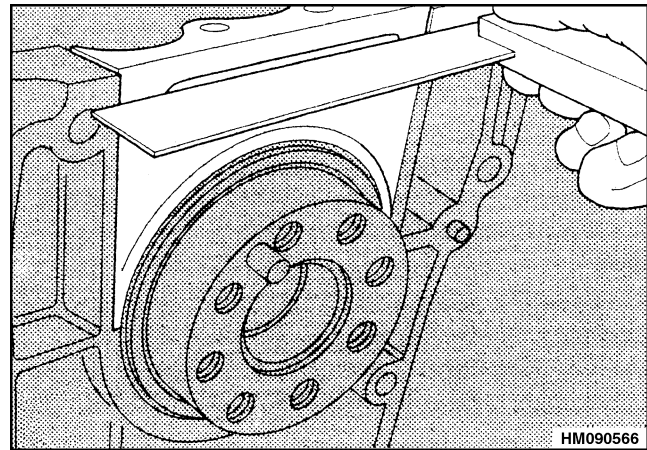

Figure 54. Front and Rear Main Bearing Alignment

13. Tighten the capscrews gradually and evenly. Tighten the capscrews to a final torque of 265 N•m (195 lbf ft). Repeat this step for all five main bearings.

NOTE: After the rear main bearing cap has been tightened, remove all excess sealant from the inside of the rear oil seal recess.

14. Install the connecting rod bearing caps on the connecting rod. Make sure the assembly numbers are matched on the same side of the connecting rod.
15. Install the nuts for the bearing cap. Tighten each nut gradually and evenly to 54 N•m (40 lbf ft).

14. Turn the crankshaft slowly in the clockwise direction until the flow of fuel from the curved fuel line is one drop every 7 to 10 seconds.
15. When the fuel flow is correct, note the reading on the dial indicator. The dial indicator shows piston displacement or static timing angles. See Engine Specifications for correct data.

NOTE: If it is necessary to adjust the timing, remove the fuel injection pump and install a shim of the correct thickness. See Fuel Injection Pump.

To retard the timing, install a thicker shim. To advance the timing, install a thinner shim. The timing changes approximately 1 degree for each 0.10 mm (0.004 in.) of shim thickness.

16. If a new shim is installed to correct the timing, repeat Step 13 through Step 15.
17. Remove the curved fuel line, the collection container, and the small fuel tank.
18. Remove the delivery valve assembly from the fuel pump.
19. Assemble the components of the delivery valve assembly as shown in Figure 83.



CAUTION

DO NOT tighten the delivery valve assembly unless all the components inside the body are

aligned. The fuel injection pump will be damaged.

20. Install the delivery valve assembly onto fuel outlet number one of the fuel injection pump.
21. Tighten the delivery valve assembly to 43 N•m (32 lbf ft).
22. Install the high-pressure fuel line to the delivery valve assembly on the fuel injection pump and tighten the union nut to 22 N•m (195 lbf in).
23. Install the low-pressure fuel line to the input of the fuel injection pump. Tighten the banjo bolt to 22 N•m (195 lbf in) and the nut to 12 N•m (106 lbf in).
24. Remove the dial indicator.
25. Install the valve spring and cap, the rocker lever, the washer, and the snap ring. Set the valve clearance for the number one inlet valve to 0.35 mm (0.014 in.).
26. Install the valve cover. See Valve Cover, Install.
27. Install the electrical stop solenoid. See Electrical Stop Solenoid, Install.
28. Connect the battery and start the engine. Check for fuel and oil leaks.

Lubrication System Repair

DESCRIPTION

The oil pump is turned by a gear on the crankshaft through an idler gear. A relief valve on the outlet of the oil pump controls the maximum oil pressure in the lubrication system. The engine oil flows from the oil pump through the oil filter to the main oil passage in the cylinder block. The oil filter has a bypass that permits oil flow directly to the main oil passage if the oil filter becomes too dirty. The normal oil flow is through the oil filter to the main oil passage in the cylinder block.

Engine oil from the main oil passage flows to the main bearings of the crankshaft and through the passages in the crankshaft to the rod bearings. The pistons and cylinder bores are lubricated by splash and oil mist.

Engine oil also flows from the main bearings to the journals of the camshaft. Some engine oil goes through the center camshaft bearing to the rocker arm assembly.

The hub of the idler gear has an oil passage to the main oil passage. The oil flow through the hub lubricates the timing gears.

OIL FILTER, REPLACE



CAUTION

DO NOT overfill the sump with oil. The engine will be damaged if it is operated with too much oil in the sump.

1. Change the oil filter when the engine oil is changed.

NOTE: The maximum travel of the rack from one end to the other is only 8 mm (0.315 in.).

12. While holding the rack in position, turn the adjustment knob on the end of the tool until the tip of the tool just touches the end of the rack. Tighten the nut on the tool to hold the tool in this position.
13. Disconnect the governor link from the peg on the fuel injection pump rack. See Fuel Injection Pump, Remove.
14. Remove the capscrew on the maximum fuel screw. Measure and record the position of the maximum fuel screw, the high-idle screw, and the low-idle screw.

Set Adjustment Screw for Maximum Fuel Setting

 **CAUTION**

The maximum fuel setting can be affected when the timing case is removed from the engine. Before removing the timing case, record the maximum fuel setting, the high-idle setting, and the low-idle setting. See Record Maximum Fuel Position of Fuel Rack.

1. Make sure the lever clamp and the rack setting tool are still installed correctly. Make sure the fuel injection pump rack and lever clamp tool are in the maximum fuel position. See Record Maximum Fuel Position of Fuel Rack.
2. With the rack and tool in the maximum fuel position, turn the maximum fuel adjustment screw until the tip of the tool just touches the fuel control lever inside the timing case. See Figure 117.
3. Use a screwdriver to hold the adjustment screw in position and tighten the screw to 12 N•m (106 lbf in).
4. Make sure the rack and lever clamp tool are still in the maximum fuel position.
5. Install the washer and capscrew on the maximum fuel setting screw and tighten to 12 N•m (106 lbf in).
6. Make sure the high-idle and low-idle speed adjustment screws are set to the measurement recorded in Record Maximum Fuel Position of Fuel Rack.

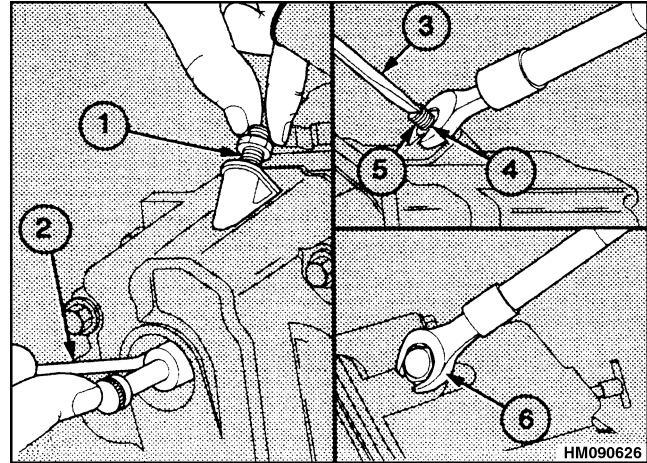

- | | |
|---------------------|---------------------|
| 1. ADJUSTMENT SCREW | 4. LOCK NUT |
| 2. LEVEL CLAMP TOOL | 5. ADJUSTMENT SCREW |
| 3. SCREWDRIVER | 6. CAP NUT |

Figure 117. Maximum Fuel Adjustment Screw Adjustment

7. Remove the lever clamp from the bore of the timing case.
8. Apply liquid gasket to the face of the access hole in the timing case and install the access plug.
9. Remove the rack setting tool from the electrical stop solenoid flange. Install the electrical stop solenoid. See Electrical Stop Solenoid, Install.
10. Install the low-pressure fuel lines and the fuel filter. See Fuel Filter, Replace.
11. Make sure the governor link and the springs are installed correctly. Install the blanking plate, with a new gasket, on the fuel injection pump.
12. Connect the return spring to the engine speed control lever. See Engine Speed Control Assembly, Install.
13. Remove the air from the fuel system. See Fuel System Air Removal.
14. Connect the fuel linkage cables and install the battery.
15. Start the engine and check for leakage.
16. Check both idle speed and maximum no-load speed.

COOLING SYSTEM**Nuts and Screws, Coolant Pump to Engine Block**

M8 22 N•m (195 lbf in)

Capscrews, Fan and Pulley to Hub

M8 22 N•m (195 lbf in)

Capscrews, Fan and Pulley to Hub

M6 9 N•m (80 lbf in)

FLYWHEEL**Capscrews, Flywheel to Crankshaft**

M12 100 N•m (77 lbf ft)

VALVE COVER**Cap Nuts, Valve Cover**

M8 11 N•m (987 lbf in)

M6 9 N•m (80 lbf in)

Capscrews, Air Breather

M6 9 N•m (80 lbf in)

ELECTRICAL EQUIPMENT**Nut, Alternator Pulley**

M17 60 N•m (44 lbf ft)

Bolt and Nut, Alternator to Timing Case

M10 24 N•m (212 lbf in)

Capscrew, Adjusting Lever to Alternator

M8 12 N•m (106 lbf in)

Glow Plugs

M10 17 N•m (150 lbf in)

Glow Plug Connections

M4 1.5 N•m (13 lbf in)

Special Tools

Tool Number	Description
PD.1D	Remove and replace tool for valve guides
PD.1D/2	Spacer used with PD.1D
PD.1D-13	Adapter tool for use with PD.1D
PD.41D	Gauge for piston height and valve depth
PD.170	Replacement tool for front oil seal
PD.184	Slide hammer
PD.208	Dial gauge for use with PD.41D
PD.243	Rubber plug replacement tool
PD.244	Adapter for use with PD6118B
PD.249	Adapter for valve guide depth, for use with PD.1D-13
PD.254	Kit, governor arm lock, consists of tools to measure rack movement
PD.255	Replacement tool for rear oil seal, for use with MS.550
PD.256	Replacement tool for idler gear, for use with MS.550
PD.258	Adapter and removal tool for idler hub, for use with PD.184
PD.259	Adapter, main tool to crankcase, for use with PD.170
PD.260	Adapter for front seal, for use with PD.170

WIRE	COLOR	GAGE
A	LT/BLUE	18
C	WHITE	18
D	BROWN	18
G	ORANGE	18
L	BROWN	14
AB	YELLOW	14
AE	BROWN	16
AG	BLACK	16
AH	RED	12
AL	BROWN	16
AM	RED	12
BAA	PINK	16
BC	RED	10
BCC	BROWN	16
BF	RED	10
CL	TAN	18
FS	BLACK	16
KD	BLACK	16
XXB	YELLOW	16
MC	RED	16
MB	GREEN	16
BH	BLACK	16
XX	DK BLUE	16
YY	RED	16

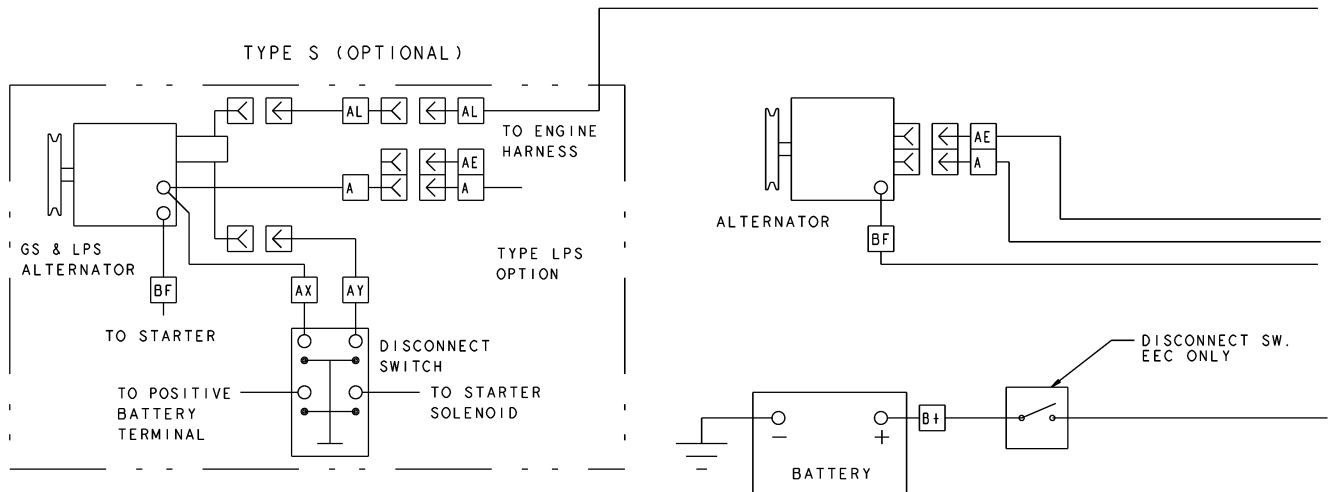
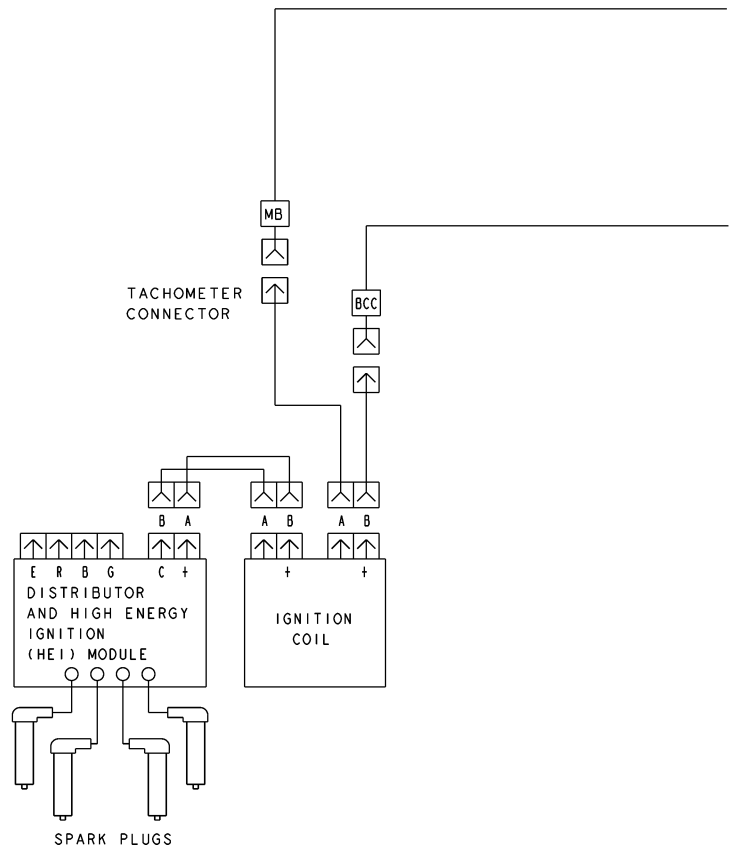

HS210004

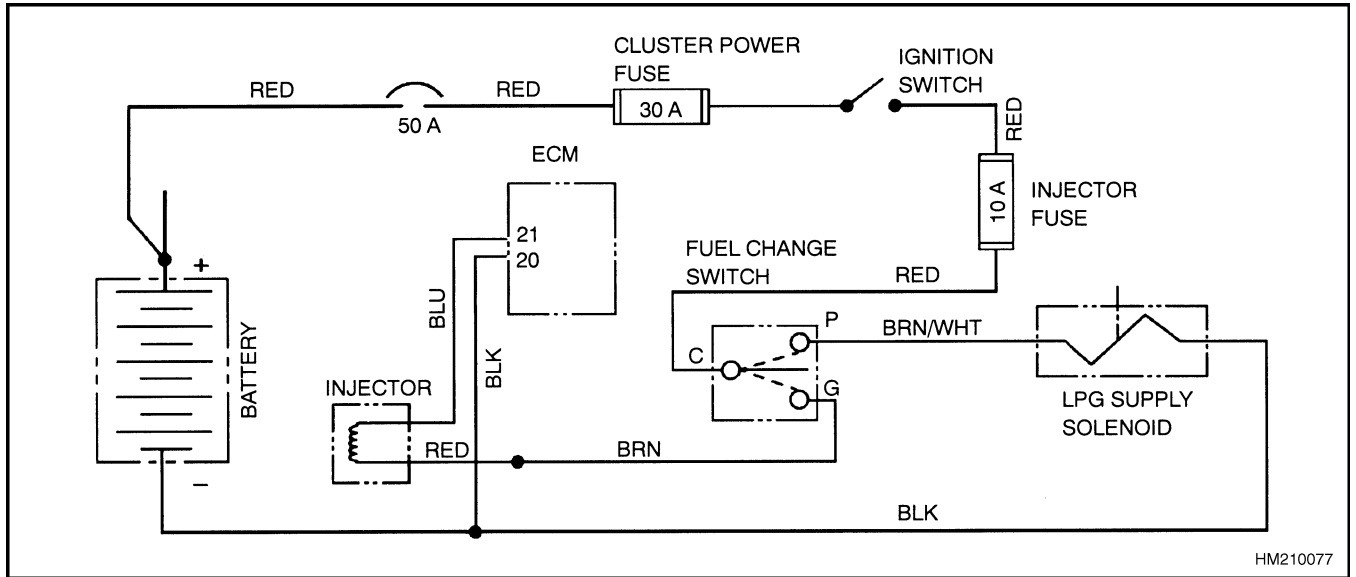

HM210077

Figure 14. Dual Fuel Option on GM 3.0L Engine Electrical Schematic

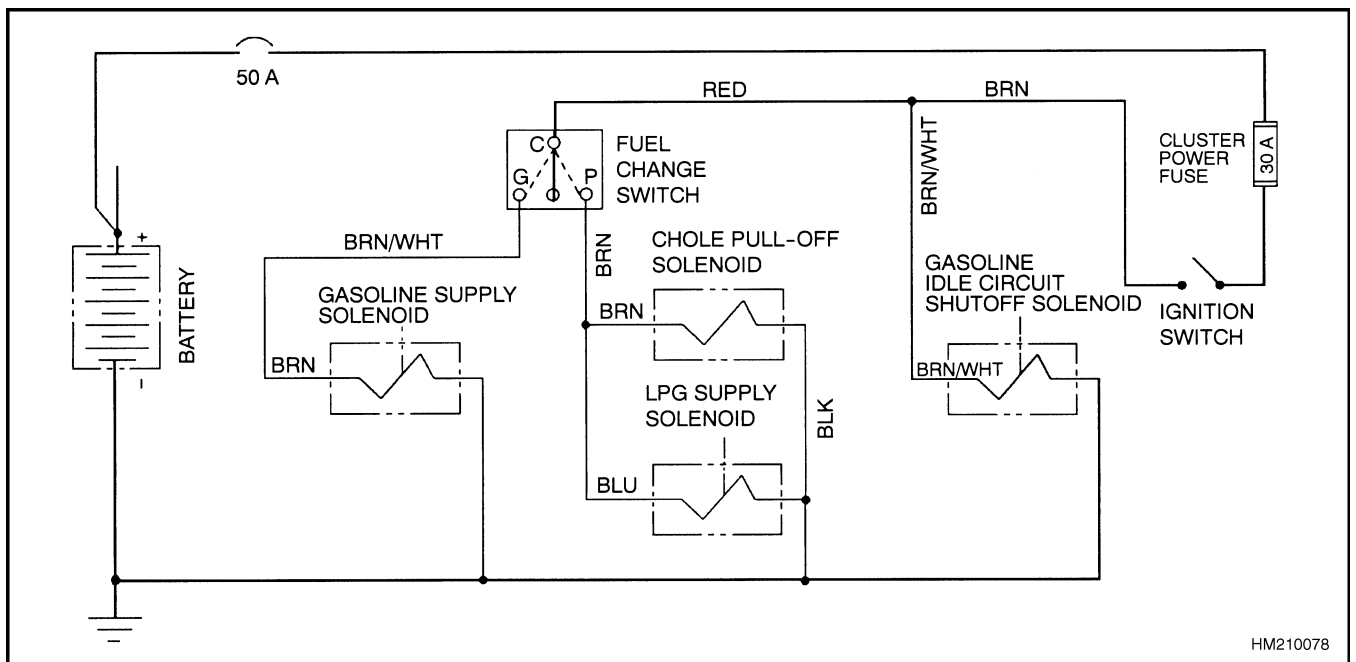

HM210078

Figure 15. Dual Fuel Option on Mazda 2.0L and 2.2L Engine Electrical Schematic

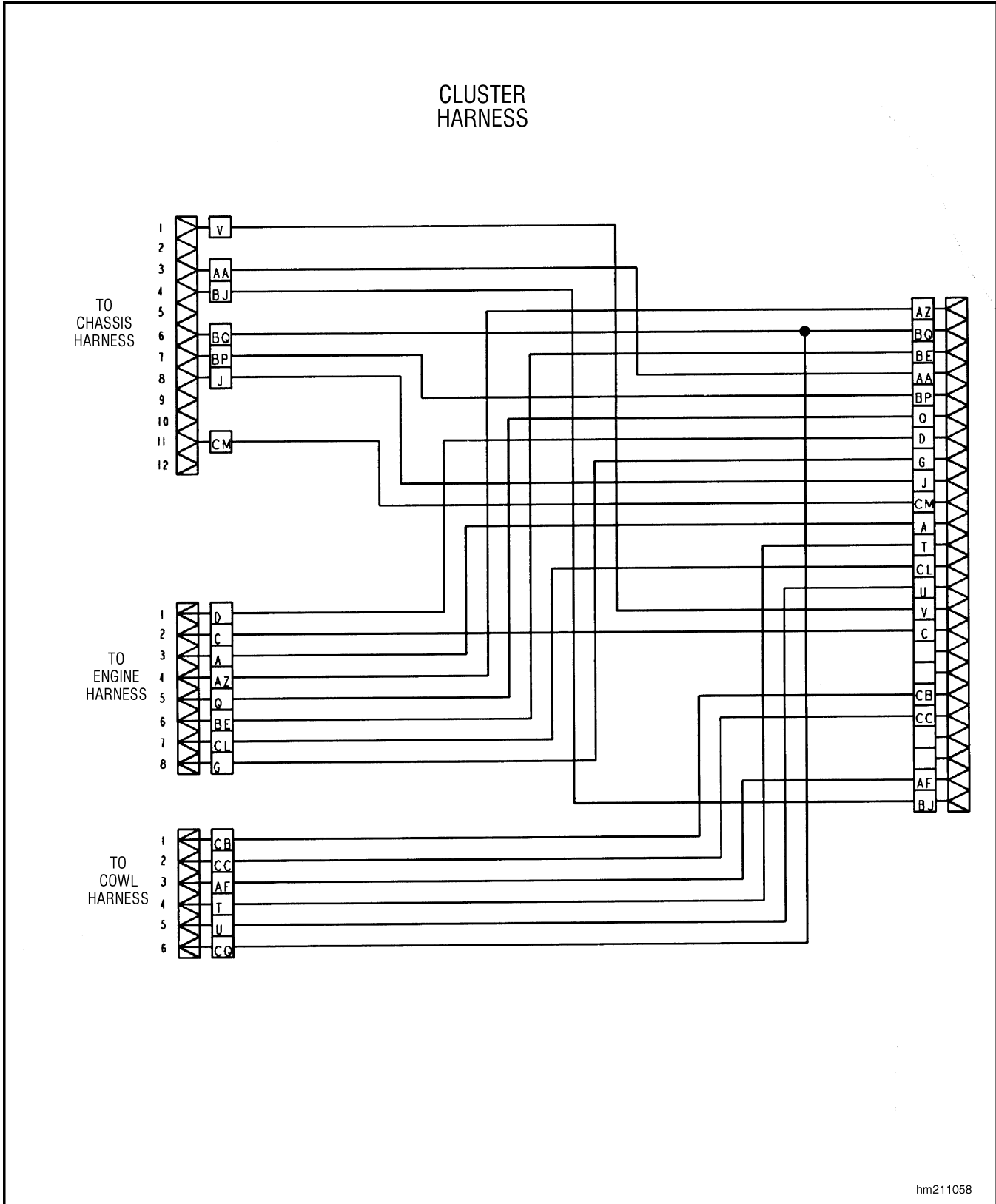

Figure 24. Instrument Cluster Harness (Later Models)

When the steering wheel stops moving, the metering action in the metering section also stops. The **NEUTRAL** position springs return the sleeve to the **NEUTRAL** position, stopping oil flow to or from the cylinder. The pressure stays in the steering cylinder to keep the steer tires in position. Oil from the pump

flows through the steering control unit to the tank or other parts of the system. To return the steer wheels to the straight position, the steering wheel must be rotated in the opposite direction. The steering control unit will operate as described, but all parts will rotate in the opposite direction.

Steering Wheel and Column Assembly Repair

The upper end of the steering shaft has splines for the steering wheel. A large hex nut holds the steering wheel onto the steering column. The horn button is the cover for the center of the steering wheel. The lower end of the steering column has splines or a tang to engage the steering control unit. See Figure 5 and Figure 6.

The steering column assembly is adjustable and held in position by a latch. The position of the steering column assembly can be changed as needed for different operator requirements. An access cover on the steering column gives access to the steering control unit, key switch, horn switch, and if installed, the direction switch.

ASSEMBLY COMPONENTS, REMOVE

NOTE: This procedure is for the removal of all components of the steering column assembly. All components are not often removed for a repair procedure. Do only those steps of the procedure necessary to remove the required component. See Figure 5 and Figure 6.



WARNING

The hydraulic hoses must be connected to the correct ports or the steering system will not operate as expected, which can cause damage or personal injury. Make sure the hoses are identified and connected correctly.



CAUTION

Disconnect the negative battery cable on internal combustion trucks. Disconnect the battery connector on electric trucks. Disconnect the battery before removing any covers.

1. Attach a tag on the battery connector or negative cable stating **DO NOT CONNECT BATTERY.**

Move the steering column to the most **FORWARD** position. Remove the column tilt lever. Remove the upper and lower access covers from the steering column.

2. Remove the key switch and static strap from the housing of the steering column. Make an identification of the electric wires and disconnect them from the key switch.
3. On units with the Direction Control Handle, Remove the direction switch assembly from the housing of the steering column. Make an identification of the electric wires and disconnect them from the direction switch. See Figure 3.
4. Remove the plastic rivets that fasten the bracket for the horn switch to the housing of the steering column. Move the horn switch and bracket away from the steering column. See Figure 5 and Figure 6.



CAUTION

If a puller tool is used to remove steering wheel from steering column, be careful not to damage the horn wires.

5. Remove the horn button assembly and electrical wires. Remove the large hex nut and the steering wheel from the shaft. A puller tool makes removal of the steering wheel easier, but not all steering wheels have puller holes.
6. On lift truck models J2.00-3.20XM (J40-60XM₂) (A216), E1.50-1.75XM, E2.00XMS (E25-40XM₂S) (D114), N30XMH, N30XMH2 (C210), and E2.00-3.20XM (E45-65XM₂) (F108) units, remove the optical encoder housing and optical encoder from the steering column. Make an identification of the electrical wires and disconnect them from the assemblies. See Figure 5.

TABLE OF CONTENTS (Continued)

This section is for the following models:

S/H1.50-2.00XMS (S/H25-40XMS) [D010, E001];

S/H2.00-3.20XM (S/H40-65XM) [D187, H177]

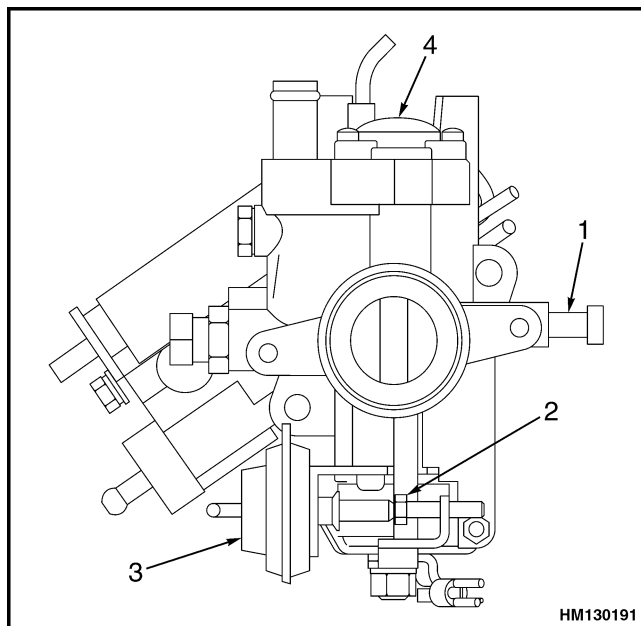

1. IDLE AIR BYPASS ADJUSTING SCREW
2. IDLE-UP ADJUSTING SCREW
3. IDLE CONTROL ACTUATOR
4. POWER VALVE ACTUATOR

Figure 20. LPG Carburetor (Top View)

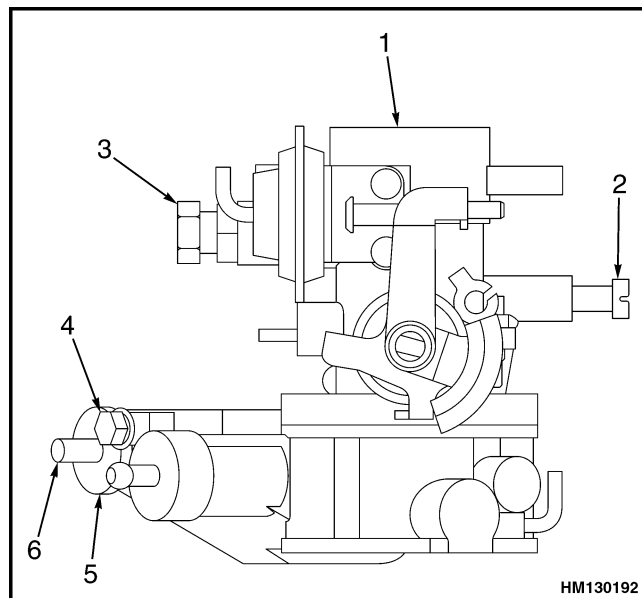

1. CARBURETOR
2. IDLE AIR BYPASS ADJUSTING SCREW
3. MAIN MIXTURE ADJUSTING SCREW
4. LOCK SCREW
5. MAIN ADJUSTMENT WHEEL
6. SECONDARY ADJUSTING SCREW

Figure 21. LPG Carburetor (Side View)

Governor Adjustment

The governor does not normally need adjustment. See Figure 22. If adjustment is necessary, do not turn adjusting screws more than 1/4 turn at a time. If adjusting screws are turned more than this, the governor can be difficult to adjust.

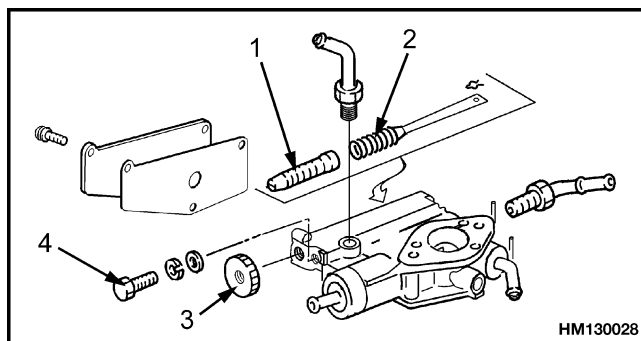

1. SECONDARY ADJUSTING SCREW
2. ADJUSTMENT SPRING
3. MAIN ADJUSTMENT WHEEL
4. LOCK SCREW

Figure 22. Governor

CHECKS

Before making any adjustments to the governor, check the following:

1. Make sure mechanical, electrical, and fuel systems are operating correctly.
2. Make sure tachometer will work with ignition system.
3. Make sure air filter is clean and connected to carburetor.

ADJUSTMENTS

With engine at operating temperature, adjust governor as follows:

1. Remove lock wire from lock screw. Loosen lock screw. Apply parking brake.
2. With no load on the engine, run engine at full open throttle to obtain maximum engine speed. To adjust maximum no-load engine speed (high

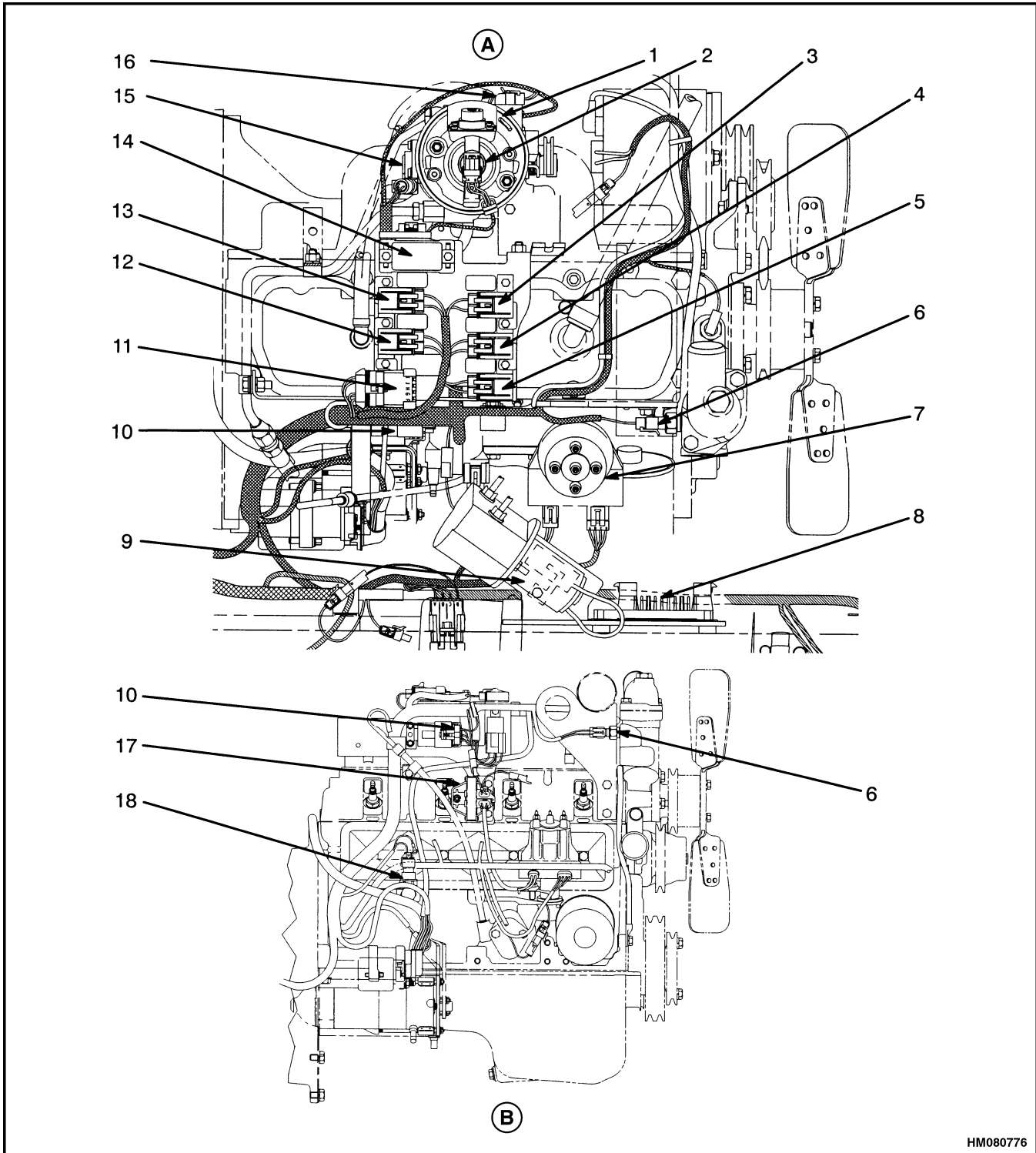

HM080776

Figure 2. Electronic Engine Control Components Arrangement (GM 3.0L Engine)

ECM SENSORS AND CONTROLLERS

Manifold Absolute Pressure (MAP)

The Manifold Absolute Pressure (MAP) sensor is a pressure transducer that measures changes in the pressure in the intake manifold. See Figure 20. The pressure changes are a result of engine load and speed changes. The MAP sensor converts these pressure changes to a signal voltage to the ECM.

The ECM sends a 5-volt reference signal to the MAP sensor. When the pressure in the intake manifold changes, the electrical resistance in the MAP sensor also changes. The change in the voltage signal from the MAP sensor enables the ECM to sense the pressure in the intake manifold.

A closed throttle causes a low pressure (high engine vacuum) in the intake manifold. This low pressure causes a low-voltage signal from the MAP sensor to the ECM. A fully opened throttle causes a higher pressure (low engine vacuum) in the intake manifold. This higher pressure causes a higher voltage signal from the MAP sensor to the ECM. These pressure changes indicate the load on the engine and send a signal to the ECM. The ECM then calculates the spark timing and fuel requirements for best engine performance.

The MAP sensor also measures the barometric pressure when the key switch is turned to **ON** and before the engine is started. The ECM remembers the barometric pressure (BARO signal) after the engine is running. This method enables the ECM to adjust the ignition timing automatically for different altitudes and atmospheric conditions.

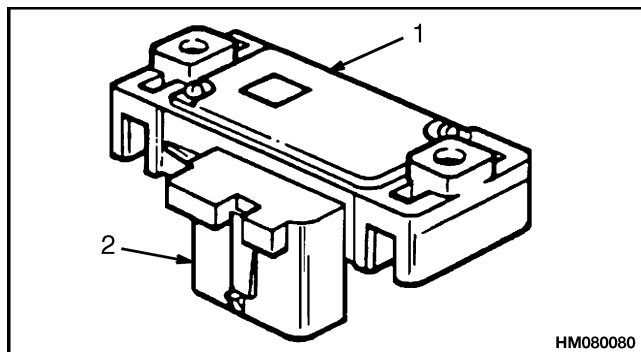

1. SENSOR
2. ELECTRICAL CONNECTOR

Figure 20. Manifold Absolute Pressure (MAP) Sensor

Engine Coolant Temperature (ECT) Sensor

NOTE: If the connection between the ECT sensor and the ECM is open during starting or operation of the engine, the ECM determines that the engine is cold and adjusts the air and fuel mixture to the full 1.5:1 ratio. This condition will set DTC Code 14 and uses a default value.

The Engine Coolant Temperature (ECT) Sensor is a resistor that changes its resistance value when the temperature changes (thermistor). See Figure 21. This sensor is installed in the engine coolant system. A low coolant temperature makes the thermistor have a high resistance [101,000 ohms at -40°C (-40°F)]. A higher coolant temperature makes the thermistor have a lower resistance [70 ohms at 130°C (266°F)].

The ECT sensor uses a thermistor to control the signal voltage to the ECM. The ECM applies a 5-volt reference voltage to the ECT sensor. The measured voltage will be high when the engine coolant is cold. The measured voltage will be lower when the engine coolant is at operating temperature. The ECM will adjust the range of the air and fuel ratio between 1.5:1 at -36°C (-33°F) and 14.7:1 at 94°C (201°F) from the ECT sensor signal. The ECM will also adjust the ignition timing for more spark advance when the engine coolant is cold and less spark advance when the engine coolant is hot. An engine at operating temperature normally needs less spark advance.

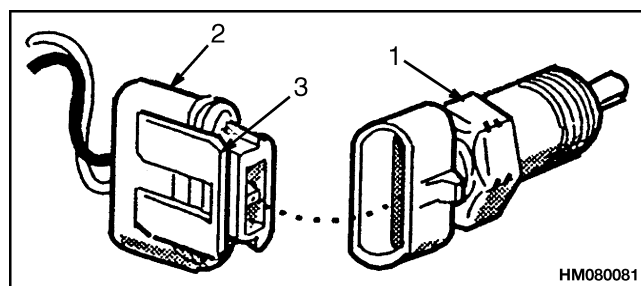

1. TEMPERATURE SENSOR
2. ELECTRICAL CONNECTOR
3. LOCK TAB

Figure 21. Engine Coolant Temperature (ECT) Sensor

Legend for Figure 4

A. TOP VIEW

1. ENGINE COOLANT TEMPERATURE SENSOR (ECT)
2. FUEL PUMP FUSE
3. ECM FUSE (B+)
4. THROTTLE POSITION SENSOR (TPS)
5. ELECTRONIC CONTROL MODULE (ECM)
6. IDLE AIR CONTROL (IAC)
7. DIAGNOSTIC CONNECTOR
8. IGNITION COIL
9. TYPE EST DISTRIBUTOR

B. VIEW FROM TRANSMISSION

10. FUEL PRESSURE TEST PORT
11. FUEL FILTER
12. THROTTLE BODY INJECTOR
13. FUEL INJECTORS
14. MANIFOLD ABSOLUTE PRESSURE (MAP) SENSOR
15. FUEL PUMP RELAY
16. OIL PRESSURE SWITCH
17. OIL PRESSURE SENDER
18. TEMPERATURE GAUGE SENDER

When SCAN Tool is connected to the Diagnostic Connector with key switch **ON** and engine **OFF**, the system will enter the Diagnostic Mode. At this point, the Malfunction Indicator Lamp will flash DTC 12 two times consecutively (see Figure 5). The following is the flash sequence for DTC 12:

1. Long pause
 2. Flash
 3. Pause
 4. Flash-flash
1. Long pause
 2. Flash
 3. Pause
 4. Flash-flash

DTC 12 (which means no crankshaft rpm signal) indicates that the ECM's diagnostic system is operating correctly at this time. If DTC 12 is not indicated, a problem is in the diagnostic system itself.

Following the output of DTC 12, if additional codes are stored, the Malfunction Indicator Lamp will flash the DTC two times. If more than one DTC has been stored in the ECM's memory, the DTC's will be flashed starting with the lowest DTC set and finishing with the highest DTC set. Remember each DTC will be flashed two times. When all DTC's have been flashed, the sequence will start over again with DTC 12.

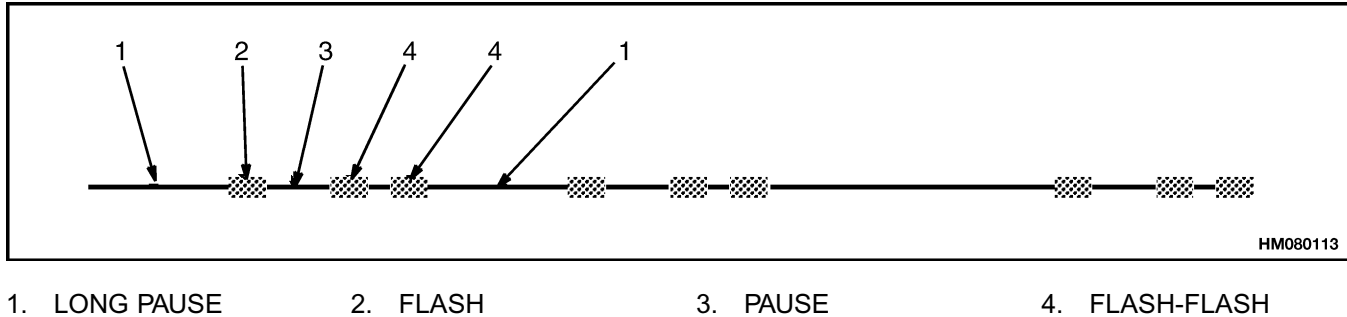

Figure 5. Diagnostic Trouble Code 12 Example

Clearing Diagnostic Trouble Codes (DTCs)

NOTE: When clearing DTC's with or without the use of a SCAN Tool, the ignition must be cycled to the OFF position or the DTC's will not clear.

Install the SCAN Tool according to the operator's manual for the tool. Select clear DTC's from the tools menu. This operation electronically clears all ECM DTC's. Check for DTC's again to see that the DTC's are cleared.

Table 10. Fuel Injector Circuit (Continued)

Step	Action	Value	Yes	No
2	<ol style="list-style-type: none"> 1. Disconnect the four-pin connector from the distributor. 2. Connect injector test light to the injector harness connector. 3. Turn ignition ON, leaving engine OFF. 4. Connect test light to a 12-volt source. 5. Momentarily touch pin C of the ignition module with the test light probe. The injector test light that is connected to the fuel injector circuit will flash each time the test light probe is removed from pin C of the ignition module. <p>Does the injector test light flash?</p>		Go to Step 12.	Go to Step 5.
3	<p>Test for short circuit to ground in circuit between injector and ECM. Is there a short circuit?</p>		Go to Step 10.	Go to Step 4.
4	<p>Check resistance across the fuel injector terminals. Is resistance the value given?</p>	1.2 Ohms	Go to Step 10.	Go to Step 13.
5	<p>Test for open/short in circuit 435. Is there a short/open indicated?</p>		Go to step 14.	Go to Step 6.
6	<ol style="list-style-type: none"> 1. Turn ignition ON, leaving engine OFF. 2. Install test light between each injector wire connection and ground. <p>Does light turn on?</p>		Light turns ON on one terminal; go to Step 7. Light turns ON on two terminals; go to Step 8.	Go to Step 9.
7	<ol style="list-style-type: none"> 1. Turn ignition OFF. 2. Connect fuel harness connector to fuel injectors. 3. Disconnect J1 (32 pin) connector from ECM. 4. Turn ignition ON, leaving engine OFF. 5. For the 3.0L engine, connect a test light between connector terminal J1-26 and ground. 6. For the 4.3L engine, connect a test light between connector terminals J1-26 and ground and J1-11 and ground. <p>Does test light illuminate?</p>		Go to Step 10.	Go to Step 11.

Table 18. DTC 15 Engine Coolant Temperature (ECT) Sensor Circuit High Temp Indicated

Step	Action	Value	Yes	No
1	Was the On-Board Diagnostic (OBD) system check performed?		Go to Step 2.	Go to On-Board Diagnostic (OBD) System Check.
2	Turn ignition ON , leaving engine OFF . Does the scan tool display a coolant temperature greater than the specified value?	130°C (266°F)	Go to Step 3.	Go to Step 4.
3	<ol style="list-style-type: none"> 1. Turn ignition OFF. 2. Disconnect ECT sensor harness connector. 3. Turn ignition ON, leaving engine OFF. Does SCAN Tool display a coolant temperature below the specified value?	-30°C (-22°F)	Go to Step 6.	Go to Step 5.
4	DTC 15 is intermittent. Locate and repair intermittent faulty connections. Refer to Diagnostic Aids.		Verify Repair.	
5	Locate and repair short to ground in circuit 430 . If a problem is found, repair as necessary. Was a problem found?		Verify Repair.	Go to Step 7.
6	Repair faulty ECT sensor. Is action complete?		Verify Repair.	
7	Repair faulty ECM connections or replace faulty ECM. Is action complete?		Verify Repair.	

DTC 21 Throttle Position (TP) Sensor Circuit Signal Voltage High

CIRCUIT DESCRIPTION

The Throttle Position (TP) sensor is a potentiometer that provides a voltage signal that changes relative to the throttle blade. Signal voltage should vary from about 0.7 volt at idle to about 4.8 volts at Wide Open Throttle (WOT).

The TP sensor signal is one of the most important inputs used by the ECM for fuel control and for IAC control.

The ECM supplies a 5-volt signal to the sensor through circuit **432**. Circuit **434** is the TP sensor ground circuit. The TP sensor will send a voltage signal back to the ECM, through circuit **433**, according to where the throttle blades are positioned. See Figure 18.

Table 33. Manifold Absolute Pressure (MAP) Sensor Output Test

Step	Action	Value	Yes	No
1	Was the On-Board Diagnostic (OBD) system check performed?		Go to Step 2.	Go to On-Board Diagnostic (OBD) System Check.
2	<ol style="list-style-type: none"> 1. Turn ignition ON, Leaving engine OFF. 2. Install Scan Tool. Scan Tool should indicate a MAP sensor voltage. 3. Compare this reading with the reading of a known good vehicle. Voltage reading should be within +0.4 Volts. (If another vehicle is not available see Table 32). <p>Is voltage within specified limits?</p>		Go to Step 3.	Go to Step 4.
3	<ol style="list-style-type: none"> 1. Disconnect vacuum source to MAP sensor and plug end of hose. 2. Connect a hand vacuum pump to MAP sensor 3. Note MAP sensor voltage shown on SCAN Tool. 4. Apply 34 kPa (10 inHg) of vacuum and note voltage change. 5. Subtract the two readings. The value should be greater than 1.5 volts. <p>Is voltage greater than 1.5 volts?</p>		Go to Step 6.	Go to Step 5.
4	Check vacuum hose for collapsed condition. If collapsed, replace MAP sensor. Is action complete?		Very repair.	
5	Check MAP sensor connector. If the connector is damaged, replace MAP sensor. Is action complete?		Verify repair.	
6	No trouble found. Check sensor vacuum source for leakage or restriction. This source supplies vacuum to the MAP sensor only. Is action complete?		Verify repair.	

**CAUTION**

Carefully lift and release lock tab on connector to sensing coil. Lock tab can be easily broken if too much force is applied with screwdriver or other tool.

7. Use a screwdriver to lift lock tab. Remove sensing coil.
8. Remove two screws that hold ignition module in housing. Remove ignition module.

Inspect

Inspect shaft for a loose fit between shaft and its bushing in housing. If bushing or shaft is worn so that shaft moves from side to side in bushing, replace shaft or housing.

Inspect housing for cracks or damage.

Assemble

NOTE: Hyster Part No. 304408 is a silicon bearing grease used between electronic components and their heat sinks. A small container of silicon grease is enclosed in package with a new ignition module.

1. Apply silicon grease to bottom of ignition module. See Figure 57. Install ignition module into housing and tighten two screws.
2. Install sensing coil. Tab on bottom of sensing coil fits into anchor hole in housing.
3. Connect sensing coil to ignition module. Make sure lock tab on connector is fastened.
4. Install retainer.
5. Install shaft assembly into housing.
6. Install seal on housing. Install gear on end of shaft.
7. Align marks on gear and shaft. Install roll pin. Turn shaft assembly and make sure teeth of timer core on shaft assembly do not touch pole piece.
8. Install rotor on shaft.

Install

1. Put rotor and distributor in same position as it was removed from engine.

If engine has been rotated after distributor was removed, the following procedure must be used before distributor is installed again:

- a. Remove No. 1 spark plug.
 - b. Put a finger over No. 1 spark plug hole and slowly rotate engine until pressure is felt on compression stroke.
 - c. Align timing mark on crankshaft pulley to 0° (TDC) on engine timing indicator.
 - d. Turn distributor rotor to point near position on distributor cap for No. 1 spark plug lead.
 - e. Install distributor in engine. Rotor and shaft will rotate a few degrees when gear on distributor shaft engages drive gear on engine cam. Timing is correct if rotor points at position on distributor cap for No. 1 spark plug lead.
2. Install clamp and bolt. Tighten bolt with your hand.
 3. Install distributor four-terminal connector.
 4. Install ignition coil connector.
 5. Install distributor cap and two capscrews. If spark plug wires were removed, install them in correct sequence.
 6. Connect battery negative cable.
 7. Start engine and check engine timing. See Distributor, Ignition Timing below for more information on Ignition Timing.
 8. Tighten bolt for distributor clamp to 43 N•m (25 lbf ft).

Firing Order

The firing order for the GM 3.0L engine is 1-3-4-2.

The firing order for the GM 4.3L engine is 1-6-5-4-3-2. See Figure 58.

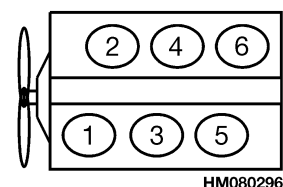

HM080296

Figure 58. Firing Order for GM 4.3L V-6

HYSTER TECHNICAL PUBLICATIONS

ECM and has no external adjustments. When the ECM determines load adjustment or maximum engine speed has been achieved, the governor overrides the foot pedal and corrects the throttle blade position.

Also mounted on throttle body assembly is the FTV. The FTV is a 12-volt normally closed solenoid valve. During closed loop operation, the ECM may send a reference signal to the FTV to open or close to allow more or less fuel to be introduced below the throttle blade to correct the air fuel mixture for proper emission control.

THREE-WAY CATALYTIC (TWC) MUFFLER

The emission certified engine has been designed and calibrated to meet the emission standards in effect for 2004. To help meet the emission requirements, the vehicle has been equipped with a TWC muffler. See Figure 7. The catalyst muffler is a three-way catalyst, sound damping, and spark arresting unit. Besides controlling the noise created from the combustion process and preventing sparks from escaping from the exhaust system, the most important function is treating the exhaust gases which are created from the combustion process. The TWC consists of a honeycomb coated with a mixture of platinum, palladium, and rhodium. The hot gases flow through the catalyst sections where an oxidation and reduction reactions take place. These chemical reactions reduce the amount of carbon monoxide (CO), hydrocarbon (HC), and nitrogen oxide (NO_x) in the engines exhaust. The exhaust gas then flows through the outlet.

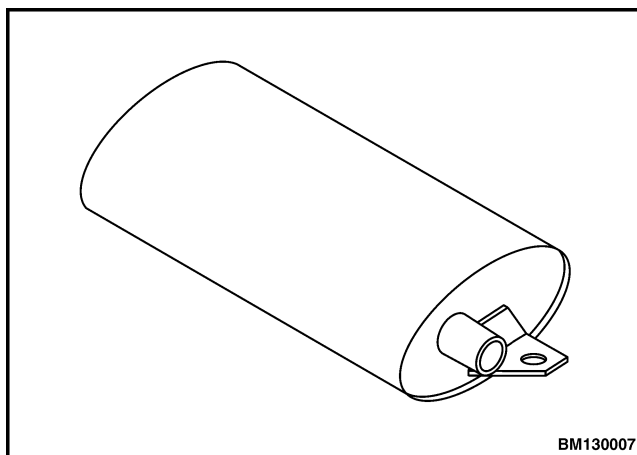

Figure 7. Three-Way Catalytic Muffler

ELECTRONIC CONTROL MODULE (ECM)

To obtain maximum effect from the catalyst and accurate control of the air fuel ratio, the emission certified engine is equipped with an on-board computer or ECM. See Figure 8. The ECM is a 32-bit controller which receives input data from sensors fitted to the engine and fuel system and then outputs various signals to control engine operation.

One specific function of the controller is to maintain closed loop fuel control. Closed loop fuel control is accomplished when the heated exhaust gas oxygen (HEGO) sensor, mounted in the exhaust system, sends a voltage signal to the controller. The controller then calculates any correction that may need to be made to the air fuel ratio. The controller then outputs signals to the PTV or the FTV or both to change the amount of fuel being delivered from the regulator or mixer or to the engine. See Figure 9.

The controller also performs diagnostic functions on the fuel system and notifies the operator of malfunctions by turning on a malfunction indicator light (MIL) mounted in the dash. Malfunctions in the system are identified by a diagnostic code number. In addition to notifying the operator of the malfunction in the system, the controller also stores the information about the malfunction in its memory. A technician can then utilize a computerized diagnostic tool to retrieve the stored diagnostic code and by using the section **Electronic Control Module (ECM) Diagnostic Troubleshooting, GM 3.0L and 4.3L EPA Compliant Engines 2200 SRM 1090**, can determine the cause of the malfunction. In the event a technician does not have the computerized diagnostic tool, the MIL light can be used to identify the diagnostic code. By following specific steps, the technician can activate the blink feature and count the number of blinks to determine the diagnostic code number to locate the fault in the system.

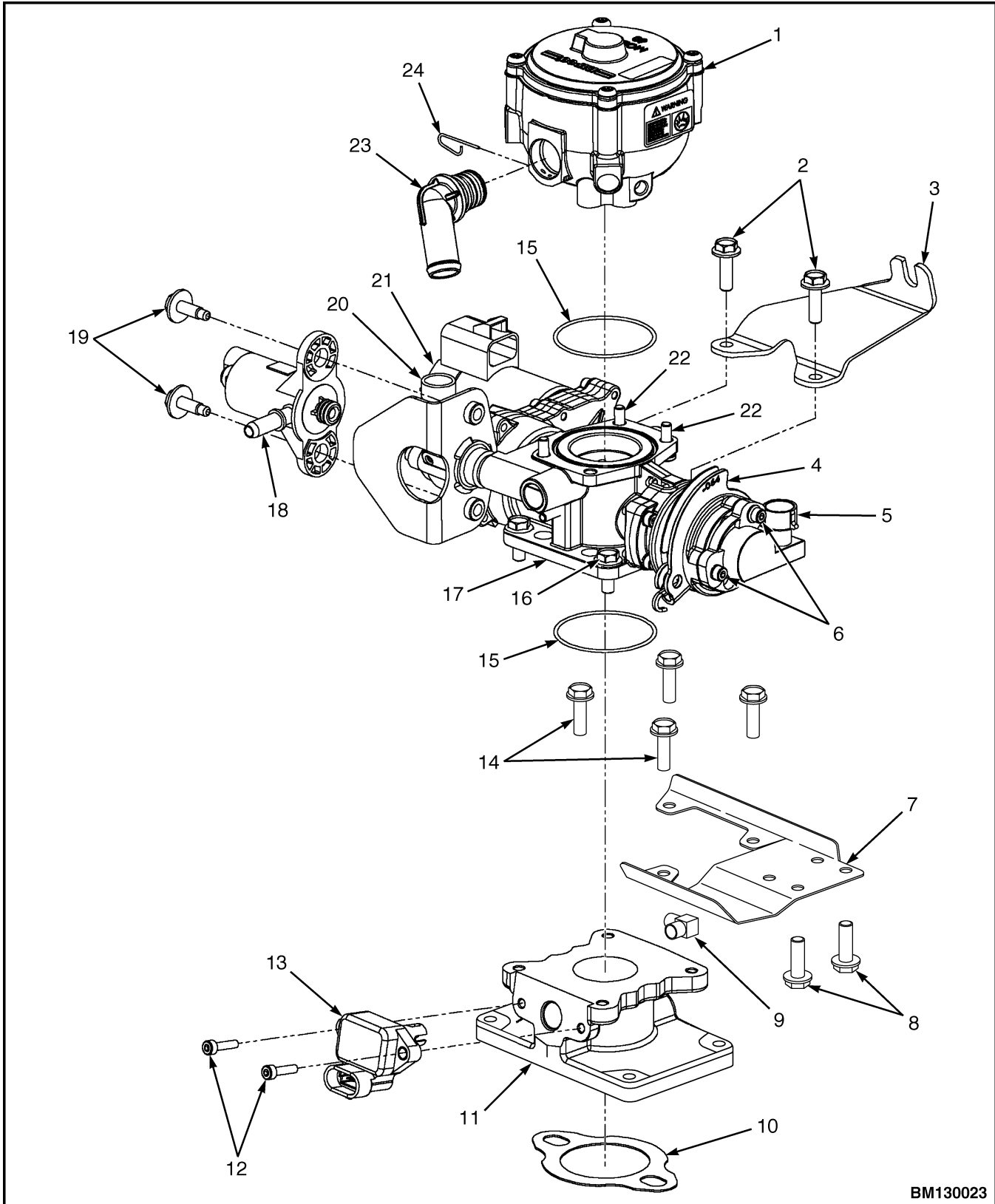

BM130023

Figure 23. 4.3L Mixer and Throttle Body Assembly

5. Disconnect the fuel return line to the rail assembly.
6. Disconnect the vacuum line to the pressure regulator.
7. Remove the four fuel rail bolts to the manifold.
8. With a screwdriver, press back on the six injector retaining clips and remove.

NOTE: Cover throttle body adapter opening to prevent debris from entering engine until assembly.

9. Carefully lift the fuel rail off the injectors.

Install

See Figure 29 for the following steps:

NOTE: Lightly lubricate both the O-rings of the throttle control device to TBI assembly.

1. Carefully place the fuel rail over all the injector and press down to set the rails.
2. Install the six injector retaining clips.
3. Secure the fuel rail to the manifold with the four retaining bolts and torque to 12 N•m (106 lbf in).
4. Connect the vacuum line to the pressure regulator.
5. Connect the fuel return line.
6. Connect the fuel supply line.
7. Install the throttle body assembly. Refer to Throttle Body Assembly Replacement, 4.3L Only, Install.
8. Install the air duct.
9. Connect the negative battery cable.
10. Start engine and check for leaks.
11. Connect the laptop computer and check for DTC codes or MIL lights. See the section **Electronic Control Module (ECM) Diagnostic Troubleshooting, GM 3.0L and 4.3L EPA Compliant Engines** 2200 SRM 1090.

INJECTOR REPLACEMENT, GASOLINE 4.3L ONLY

Remove

See Figure 29 for the following steps:

1. Disconnect the negative battery cable.
2. Relieve the fuel system pressure. Refer to Gasoline MPFI and TBI Fuel System Pressure Relief.
3. Remove the fuel rail assembly. Refer to Fuel Rail Replacement, Gasoline 4.3L Only, Remove.
4. Disconnect the six injector electrical connections.
5. Remove each injector.

Install

See Figure 29 for the following steps:

NOTE: Apply a small amount of O-ring lubricant to the injector O-rings before installation.

1. Install the injectors.
2. Connect the injector electrical connectors.
3. Install the fuel rail assembly. Refer to Fuel Rail Replacement, Gasoline 4.3L Only, Install.
4. Start engine and check for leaks.
5. Connect the laptop computer and check for DTC codes or MIL lights. See the section **Electronic Control Module (ECM) Diagnostic Troubleshooting, GM 3.0L and 4.3L EPA Compliant Engines** 2200 SRM 1090.

INJECTOR REPLACEMENT, GASOLINE 3.0L ONLY

Remove

See Figure 27 for the following steps:

1. Relieve the fuel system pressure. Refer to Gasoline MPFI and TBI Fuel System Pressure Relief.
2. Disconnect the injector electrical connection.
3. Remove the injector retaining screw.
4. Remove the injector.

Table 6. Fuel Control Diagnosis (Continued)

Step	Action	Value(s)	Yes	No
17	Check the vacuum hose to the PTV for kinks, obstruction or leakage. Was a problem found?	--	Go to Step 21	Go to Step 15
18	Check the fuel hose to the FTV for kinks, obstruction or leakage. Was a problem found?	--	Go to Step 21	Go to Step 15
19	Replace the PTV. Refer to Pressure Trim Valve (PTV) Replacement. Is this action complete?	--	Go to Step 21	--
20	Replace the FTV. Refer to Fuel Trim Valve (FTV) Solenoid Replacement. Is this action complete?	--	Go to Step 21	--
21	1. Return the fuel system to normal operating condition. 2. Observe the duty cycle reading. 3. Raise the engine speed to approximately 2500 rpm. Is the duty cycle in the specified range?	20 to 80 percent	Go to Step 25	Go to Step 22
22	Check all vacuum hoses and mixer connections for leakage. Was a problem found?	--	Go to Step 21	Go to Step 23
23	Replace mixer. Refer to Mixer Replacement. Is this action complete?	--	Go to Step 21	--
24	The fuel control system is operating normally. Refer to LPG Symptom Diagnosis. 1. Disconnect all test equipment. 2. If you were sent to this routine by another diagnostic chart, return to the previous diagnostic procedure Is this action complete?	--	System OK	--
25	1. Disconnect all test equipment. 2. Start the engine. 3. Using a liquid leak detection solution leak check any fuel system repairs made. Is this action complete?	--	System OK	--

Table 15. Backfire (Continued)

Checks	Action
Engine Mechanical Check	 CAUTION The LPG fuel system works on a fumigation principle of fuel introduction and is more sensitive to intake manifold leakage than a gasoline fuel supply system. <ul style="list-style-type: none"> • Check the engine for the following: <ul style="list-style-type: none"> - Improper valve timing - Engine compression - Manifold vacuum leaks - Intake manifold gaskets - Sticking or leaking valves - Exhaust system leakage • Check the intake and exhaust system for casting flash or other restrictions.
Fuel System Checks	Perform a fuel system diagnosis. Refer to LPG System Diagnosis.

Table 16. Lack of Power, Sluggishness, or Sponginess

Checks	Action
Definition: The engine delivers less than expected power. There is little or no increase in speed when partially applying the accelerator pedal.	
Preliminary Checks	<ul style="list-style-type: none"> • Refer to Preliminary Checks. • Refer to the On-Board Diagnostics table in the section Electronic Control Module (ECM) Diagnostic Troubleshooting, GM 3.0L and 4.3L EPA Compliant Engines 2200 SRM 1090. • Compare the vehicle with a similar unit. Do not compare the power output of the vehicle operating on LPG to a vehicle operating on gasoline as the fuels do have different drive feel characteristics. • Remove the air filter and check for dirt or restriction. • Check the vehicle transmission.
Fuel System Checks	<ul style="list-style-type: none"> • Check for a restricted fuel filter, contaminated fuel, or improper fuel pressure. Refer to LPG System Diagnosis. • Check for the proper ignition output voltage. • Check for proper installation of the mixer module assembly. • Check all air inlet ducts for condition and proper installation. • Check for fuel leaks between the LPR and the mixer. • Verify that the LPG tank manual shutoff valve is fully open. • Verify that liquid fuel (not vapor) is being delivered to the LPR.
Sensor Checks	<ul style="list-style-type: none"> • Check the HEGO sensor for contamination and performance. Check for proper operation of the MAP sensor. • Check for proper operation of the TPS and FPP sensors.

STEP 3.

Untwist conductors and strip insulation as necessary.

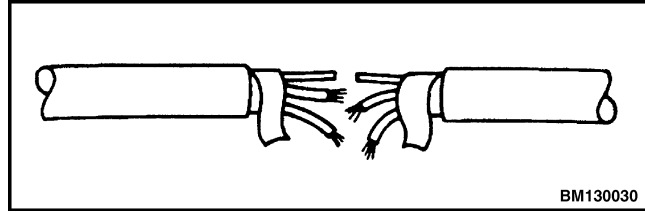

BM130030

STEP 4.

Splice wires using splice clips and rosin core solder. Wrap each splice to insulate.

STEP 5.

Wrap with mylar and drain (uninsulated) wire.

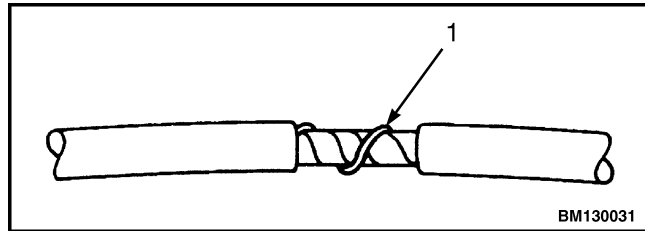

BM130031

1. DRAIN WIRE

STEP 6.

Tape over whole bundle to secure.

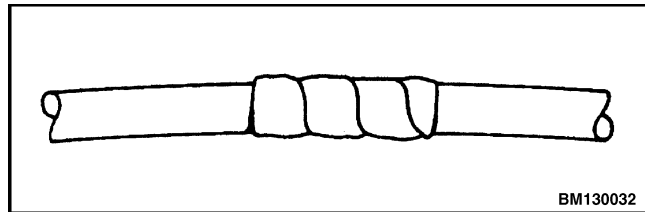

BM130032

Twisted Leads Repair

STEP 1.

Locate damaged wire and remove insulation as required.

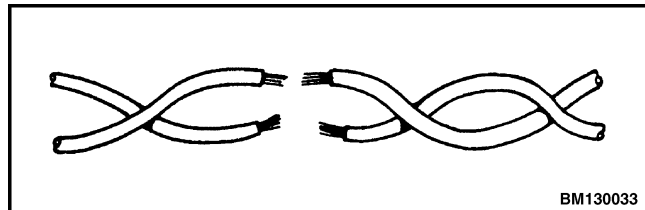

BM130033

STEP 2.

Splice the two wires together using splice clips and rosin core solder. See Figure 36.

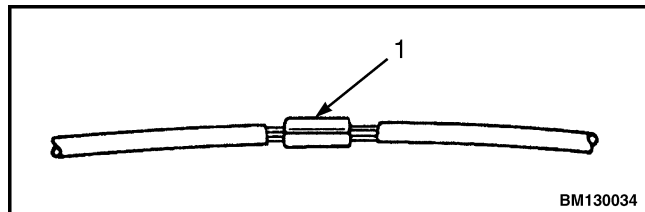

BM130034

1. SPLICE AND SOLDER

TABLE OF CONTENTS (Continued)

Conditions for Setting the DTC	264
DTC 262 - System Voltage Low	266
Circuit Description	266
Conditions for Setting the DTC	266
DTC 511 - COP Failure	268
Circuit Description	268
Conditions for Setting the DTC	268
DTC 512 - Invalid Interrupt.....	270
Circuit Description	270
Conditions for Setting the DTC	270
DTC 513 - A/D Loss	272
Circuit Description	272
Conditions for Setting the DTC	272
DTC 514 - RTI 1 Loss	274
Circuit Description	274
Conditions for Setting the DTC	274
DTC 515 - Flash Checksum Invalid	276
Circuit Description	276
Conditions for Setting the DTC	276
DTC 516 - Ram Failure	278
Circuit Description	278
Conditions for Setting the DTC	278
DTC 531 - External 5V Ref Lower Than Expected	280
Circuit Description	280
Conditions for Setting the DTC	280
DTC 532 - External 5V Ref Higher Than Expected.....	282
Circuit Description	282
Conditions for Setting the DTC	282
DTC 555 - RTI 2 Loss	284
Circuit Description	284
Conditions for Setting the DTC	284
DTC 556 - RTI 3 Loss	286
Circuit Description	286
Conditions for Setting the DTC	286
DTC 611 - FPP High Voltage.....	288
Circuit Description	288
Conditions for Setting the DTC	288
DTC 612 - FPP Low Voltage.....	292
Circuit Description	292
Conditions for Setting the DTC	292
DTC 631 - TPS1 Signal Voltage High	296
Circuit Description	296
Conditions for Setting the DTC	296
DTC 632 - TPS1 Signal Voltage Low	299
Circuit Description	299
Conditions for Setting the DTC	299
DTC 638 - Throttle Unable To Close.....	302
Circuit Description	302
Conditions for Setting the DTC	302
Diagnostic Aids.....	303
DTC 651 - Maximum Govern Speed Override	305

Table 7. Oil Pressure Connector C005

 <p style="text-align: center;">BM080374</p>		
Pin	Wire Color	Function
A	Light Green/Black	Oil Pressure

Table 8. Distributor Connector C006

 <p style="text-align: center;">BM080626</p>		
Pin	Wire Color	Function
A	Purple/Orange	Cam -
B	Light Green/Red	5 Volt Reference
C	Gray/Brown	Cam +
D	Yellow	Coil 1

Table 9. Magnetic Pickup Connector C007

 <p style="text-align: center;">BM080624</p>		
Pin	Wire Color	Function
A	Purple/White	Crank +
B	White/Purple	Crank -

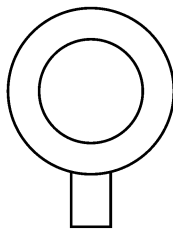
Table 10. Heated Oxygen Sensor C008

 <p style="text-align: center;">BM080379</p>		
Pin	Wire Color	Function
A	Black/Light Green	Analog Return
B	Dark Green/Orange	EGO 1
C	Pink/Dark Green	Relay Fused Power
D	Black	Power Ground

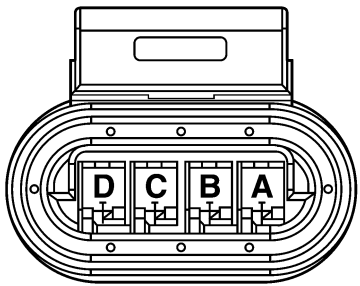
Table 30. DTC 112 - IAT Low Voltage (Motorola® TMAP)

Step	Action	Value(s)	Yes	No
1	Did you perform the On-board diagnostics (OBD) system check?		Go to step 2.	Go to On-Board Diagnostics System Check/ Malfunction Indicator Lamp.
2	<ul style="list-style-type: none"> • Key ON. • Laptop computer connected in system data mode. Does laptop computer display IAT voltage of 0.05 or less?		Go to step 3.	Intermittent problem. Go to Preliminary and Intermittent Checks.
3	<ul style="list-style-type: none"> • Key OFF. • Disconnect the TMAP sensor wire harness connector. • Turn the key to the ON position. Does the laptop computer display IAT voltage of 4.9 volts or greater?		Go to step 4.	Go to step 5.
4	<ul style="list-style-type: none"> • Replace TMAP sensor. Is the replacement complete?		Go to step 9.	
5	<ul style="list-style-type: none"> • Key OFF. • Disconnect ECM wire harness connector. • Check for continuity between TMAP sensor connector ground pin A and TMAP sensor connector signal pin B. Do you have continuity between them?		Repair the circuit as necessary. Refer to Wire Harness Repair. Go to step 8.	Go to step 6.
6	<ul style="list-style-type: none"> • Check for continuity between TMAP sensor connector signal circuit pin B and engine ground. Do you have continuity?		Repair the circuit as necessary. Refer to Wire Harness Repair. Go to step 8.	Go to step 7.
7	<ul style="list-style-type: none"> • Replace the ECM. Is the replacement complete?		Go to step 8.	

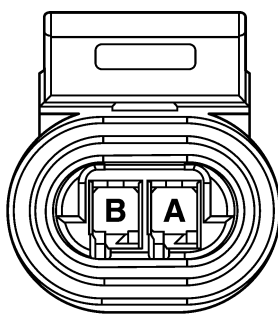
**DTC 131 - MAP HIGH PRESSURE
MOTOROLA® TMAP**

Circuit Description

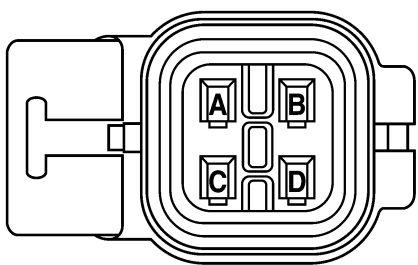
The TMAP is a combined inlet manifold temperature and pressure sensor connected to the intake manifold. It is used to measure the pressure of air in the manifold prior to induction into the engine. The pressure reading is used in conjunction with other inputs to determine the airflow rate to the engine, which also determines the fuel flow rate. See Figure 21.

This fault will set when the MAP reading is higher than it should be for the given TPS, and RPM. When the fault is set, the Adaptive Learn will be disabled for the remainder of the key ON cycle and the MIL will be on. The engine will operate on a default MAP during this active fault.

Conditions for Setting the DTC

- Manifold absolute pressure.
- Check condition - engine speed is greater than 1800 rpm, TPS less than 10 percent, and steady MAP and TPS.
- Fault condition - MAP greater than 14 psia, TPS less than 10 percent, and engine speed is greater than 1800 rpm.
- MIL - on for active fault.
- Adaptive - disabled for remainder of key ON cycle.
- Miscellaneous - fueling is based on rpm and TPS limp-home condition during this fault.

Diagnostic Aids

If the engine is running rough, unstable, or missing due to a suspected mechanical problem, vacuum leak or other issue causing misfire, these problems must be taken care before using Table 37. Failure to follow this recommendation will result in a false MAP diagnostic and repair procedure.

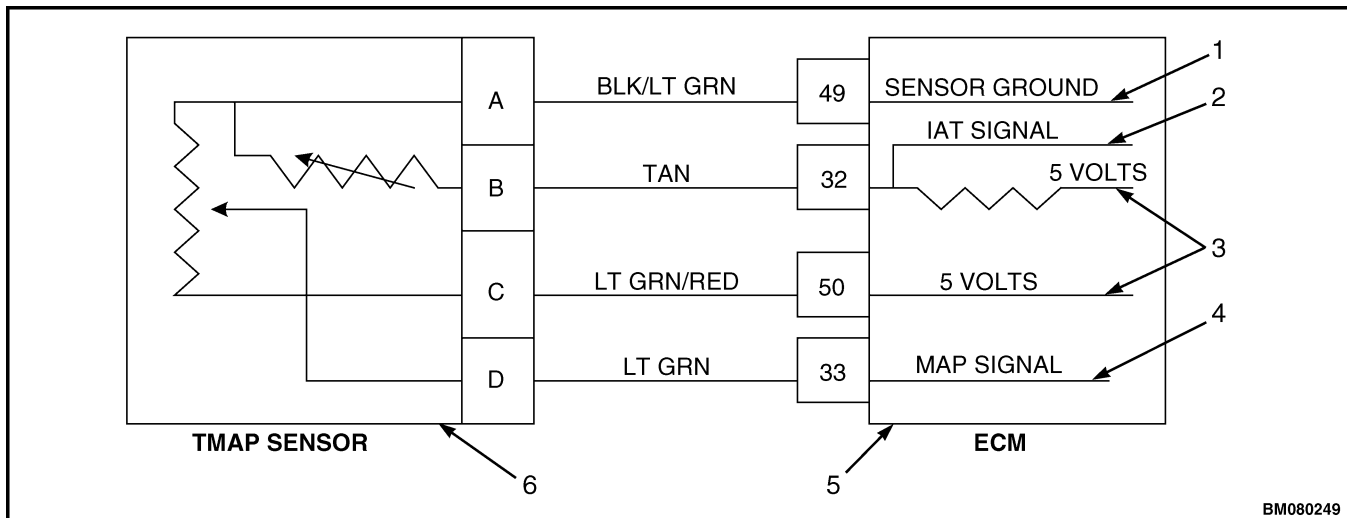

BM080249

1. SENSOR GROUND
2. INTAKE AIR TEMPERATURE (IAT) SIGNAL
3. 5 VOLTS
4. MANIFOLD ABSOLUTE PRESSURE (MAP) SIGNAL
5. ELECTRONIC CONTROL MODULE (ECM)
6. TEMPERATURE MANIFOLD ABSOLUTE PRESSURE (TMAP) SENSOR

Figure 21. TMAP Sensor Circuit (Motorola® TMAP)

Table 42. DTC 143 - Never Crank Synced At Start (Continued)

Step	Action	Value(s)	Yes	No
3	<ul style="list-style-type: none"> • Key OFF. • Disconnect the crankshaft position sensor (CKP) connector. • Using a DVOM check for voltage at the CKP sensor connector while cranking the engine. <p>Do you have voltage?</p>	Over 0.5 volts	Go to step 4.	Go to step 11.
4	<ul style="list-style-type: none"> • Key OFF. • Disconnect ECM connector C001. • Using a DVOM check for continuity between CKP connector pin B and ECM connector pin 12. <p>Do you have continuity between them?</p>		Go to step 5.	Repair the circuit as necessary. Refer to Wire Harness Repair. Go to step 16.
5	<ul style="list-style-type: none"> • Using a DVOM check for continuity between CKP connector pin A and ECM connector pin 11. <p>Do you have continuity between them?</p>		Go to step 6.	Repair the circuit as necessary. Refer to Wire Harness Repair. Go to step 16.
6	<ul style="list-style-type: none"> • Inspect the CKP connector C007 pins for damage, corrosion or contamination. <p>Did you find a problem?</p>		Repair the circuit as necessary. Refer to Wire Harness Repair. Go to step 16.	Go to step 7.
7	<ul style="list-style-type: none"> • Inspect the ECM connector C001 pins 11 and 12 for damage, corrosion or contamination. <p>Did you find a problem?</p>		Repair the circuit as necessary. Refer to Wire Harness Repair. Go to step 16.	Go to step 8.
8	<ul style="list-style-type: none"> • Using a DVOM, check for continuity between ECM connector pins 11 and 12 to engine ground. <p>Do you have continuity?</p>		Repair the circuit as necessary. Refer to Wire Harness Repair. Go to step 16.	Go to step 10.
9	<ul style="list-style-type: none"> • Replace CKP sensor. <p>Is the replacement complete?</p>		Go to step 16.	
10	<ul style="list-style-type: none"> • Replace the ECM. <p>Is the replacement complete?</p>		Go to step 16.	

DTC 222 - CLOSED LOOP MULTIPLIER LOW (GASOLINE)

Circuit Description

The heated oxygen sensor (HO₂S) sensor is used to determine if the fuel flow to the engine is correct by measuring the oxygen content in the exhaust gas. The ECM uses this information to correct the fuel flow with the closed loop multiplier and the adaptive multiplier. See Figure 32.

This fault sets if the closed loop multiplier exceeds the limits of normal operation. When the multiplier cannot correctly modify the fuel flow within its limits, it is limited at -35 percent.

Conditions for Setting the DTC

- Heated oxygen sensor.
- Functional fault - closed loop multiplier out of range (at limit of -35%).
- MIL - on during active fault and for one update after active fault.
- Adaptive - enabled.
- Closed loop - enabled.

Diagnostic Aids

Always diagnose any other ECM codes that are present before beginning this diagnostic procedure.

Fuel system - the system will be rich if an injector fails in an open manner. High fuel pressure due to a faulty fuel regulator or obstructed fuel return line will cause the system to run rich.

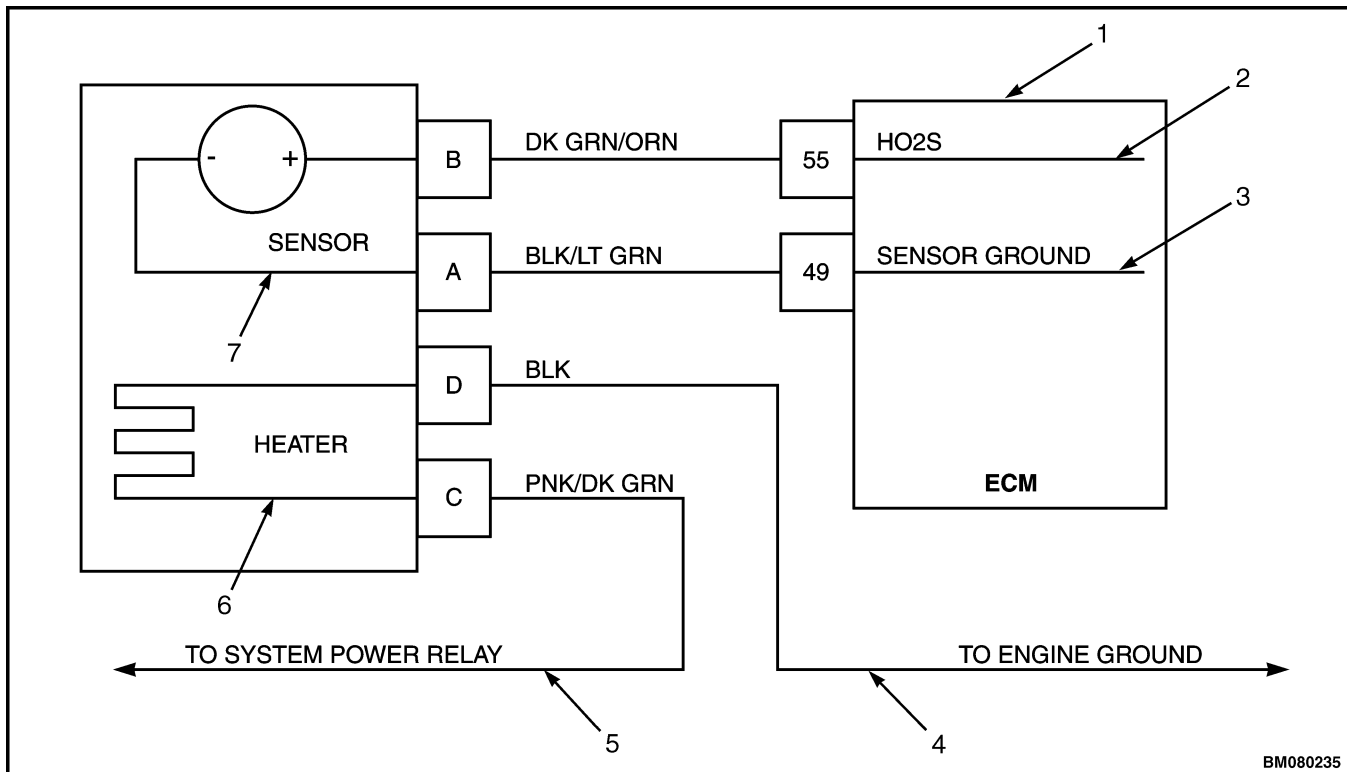

- | | |
|---|--------------------------|
| 1. ELECTRONIC CONTROL MODULE (ECM) | 5. TO SYSTEM POWER RELAY |
| 2. HEATED OXYGEN SENSOR (HO ₂ S) | 6. HEATER |
| 3. SENSOR GROUND | 7. SENSOR |
| 4. TO ENGINE GROUND | |

Figure 32. Heated Oxygen Sensor Circuit

Table 54. DTC 261 - System Voltage High

Step	Action	Value(s)	Yes	No
1	Did you perform the On-board diagnostics (OBD) system check?		Go to step 2.	Go to On-Board Diagnostics System Check/Malfunction Indicator Lamp.
2	<ul style="list-style-type: none"> • Key ON and engine running. • Laptop computer connected in system data mode. • Run engine greater than 1500 rpm. <p>Does laptop computer display system voltage less than 18 volts?</p>		Go to step 3.	Intermittent problem. Go to Preliminary and Intermittent Checks.
3	<ul style="list-style-type: none"> • Check voltage at battery terminals with DVOM, with engine speed greater than 1500 rpm. <p>Is it greater than 18 volts?</p>		Go to step 4.	Go to step 5.
4	<ul style="list-style-type: none"> • Repair the charging system. <p>Has the charging system been repaired?</p>		Go to step 6.	
5	<ul style="list-style-type: none"> • Replace the ECM. 		Go to step 6.	
6	<ul style="list-style-type: none"> • Remove all test equipment except the laptop computer. • Connect any disconnected components, fuses, etc. • Using the laptop computer, clear DTC information from the ECM. • Turn the ignition OFF and wait 30 seconds. • Start the engine and operate the vehicle to full operating temperature. • Observe the MIL. • Observe engine performance and driveability. • After operating the engine within the test parameters of DTC 261, check for any stored codes. <p>Does the engine operate normally with no stored codes?</p>		System OK.	Go to On-Board Diagnostics System Check/Malfunction Indicator Lamp.

DTC 515 - FLASH CHECKSUM INVALID**Circuit Description**

The ECM has checks that must be satisfied each time an instruction is executed. Several different things can happen within the microprocessor that will cause this fault. The ECM will reset itself in the event this fault is set, and the MIL will be on until the code is cleared. This fault should be erased after diagnosis by removing battery power. It will not self-erase. See Figure 46.

During this active fault, power derate (level 2) will be enforced. When this is enforced, maximum throttle

position will be 20 percent. This is enforced until the fault is manually cleared.

Conditions for Setting the DTC

- Electronic control module.
- Check condition - key **ON**.
- Fault condition - internal microprocessor error.
- MIL - on until code is cleared by technician.
- Adaptive - disabled for the remainder of the key **ON** cycle.
- Closed loop - enabled.
- Power derate - level 2 until fault is cleared manually.

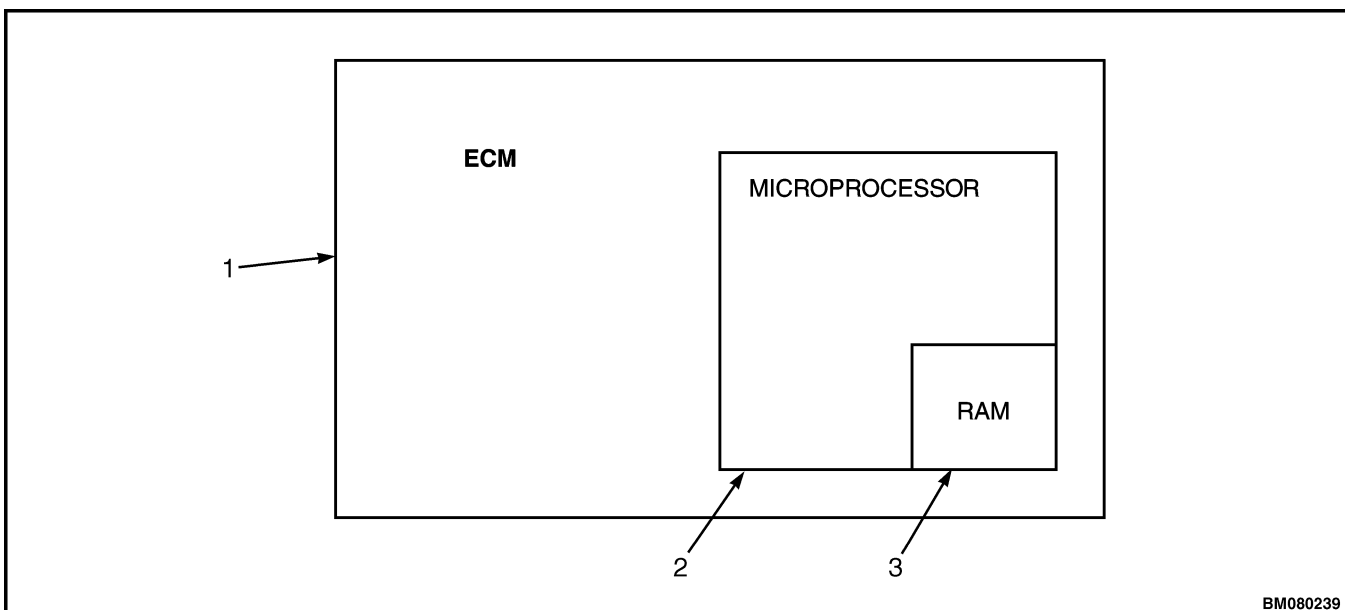

BM080239

1. ELECTRONIC CONTROL MODULE (ECM)
2. MICROPROCESSOR
3. RAM

Figure 46. ECM Microprocessor

Table 69. DTC 612 - FPP Low Voltage

Step	Action	Value(s)	Yes	No
1	Did you perform the On-board diagnostics (OBD) system check?		Go to step 2.	Go to On-Board Diagnostics System Check/Malfunction Indicator Lamp.
2	<ul style="list-style-type: none"> • Key ON and engine OFF. • Laptop computer connected in system data mode. Does the laptop computer display FPP voltage of 0.5 volts or less with the foot pedal in the idle position?		Go to step 7.	Go to step 3.
3	<ul style="list-style-type: none"> • Slowly depress the foot pedal while observing FPP voltage. Does laptop computer FPP voltage ever drop below 0.5 volts?		Go to step 4.	Intermittent problem. Go to Preliminary and Intermittent Checks.
4	<ul style="list-style-type: none"> • Key OFF. • Disconnect FPP sensor connector. • Inspect connector and wire terminals for damage, corrosion or contamination. Did you find a problem?		Repair the circuit as necessary. Refer to Wire Harness Repair. Go to step 18.	Go to step 5.
5	<ul style="list-style-type: none"> • Key ON. • Using a DVOM, check for voltage at the FPP sensor connector between 5-volt reference pin A and FPP sensor ground pin B. Do you have voltage between them?	5.0 volts	Go to step 6.	Repair the circuit as necessary. Refer to Wire Harness Repair. Go to step 18.
6	<ul style="list-style-type: none"> • Replace FPP sensor. Refer to the section Electronic Controlled LPG/Gasoline Fuel System, GM 3.0L and 4.3L EPA Compliant Engines 900 SRM 1088. Is the replacement complete?		Go to step 18.	
7	<ul style="list-style-type: none"> • Key OFF. • Disconnect FPP sensor from wire harness. • Jumper 5-volt reference circuit pin A and FPP signal circuit pin C together. • Key ON. Does laptop computer display FPP voltage of 4.8 volts or greater?		Go to step 8.	Go to step 9.

Table 74. DTC 652 - Fuel Rev Limit (Continued)

Step	Action	Value(s)	Yes	No
8	<ul style="list-style-type: none"> Check engine for large manifold vacuum leaks. <p>Did you find and correct the vacuum leak?</p>		Go step 9.	Go to On-Board Diagnostics System Check/Malfunction Indicator Lamp.
9	<ul style="list-style-type: none"> Remove all test equipment except the laptop computer. Connect any disconnected components, fuses, etc. Using the laptop computer, clear DTC information from the ECM. Turn the ignition OFF and wait 30 seconds. Start the engine and operate the vehicle to full operating temperature. Observe the MIL. Observe engine performance and driveability. After operating the engine within the test parameters of DTC 652, check for any stored codes. <p>Does the engine operate normally with no stored codes?</p>		System OK.	Go to On-Board Diagnostics System Check/Malfunction Indicator Lamp.

DTC 653 - SPARK REV LIMIT

Circuit Description

This fault will set anytime the engine rpm exceeds:

- 3300 rpm for greater than 0.250 seconds for cushion model trucks.
- 3400 rpm for greater than 0.250 seconds for pneumatic model trucks.

This is to help prevent engine or equipment damage in the event of a governor failure. The MIL will be on during this active fault. See Figure 59.

Conditions for Setting the DTC

- Maximum govern speed override.
- Check condition - engine running.
- Fault condition - engine rpm greater than specified for 0.250 seconds.
- MIL - on during active fault.
- Engine shutdown.

Diagnostic Aids

This fault is an indication of a problem in the speed governing control system. This DTC will most likely be accompanied by other DTC codes related to the speed governing control system. Always diagnose and repair starting with the lowest DTC code number in the event of multiple code sets.

CLICK HERE TO **DOWNLOAD** THE COMPLETE MANUAL

- Thank you very much for reading the preview of the manual.
- You can download the complete manual from: www.heydownloads.com by clicking the link below



- Please note: If there is no response to CLICKING the link, please download this PDF first and then click on it.

CLICK HERE TO **DOWNLOAD** THE COMPLETE MANUAL

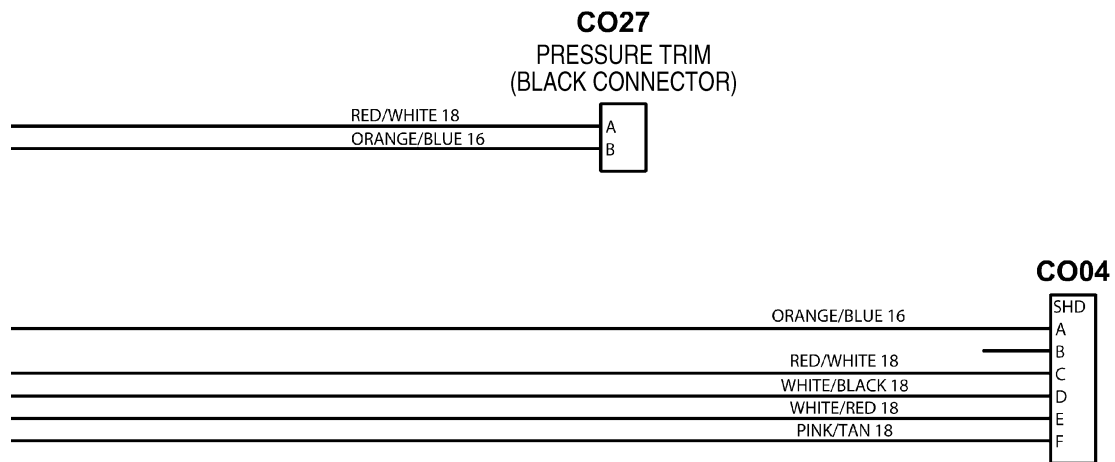

BM080394

Figure 61. 4.3L LPG Jump Harness

DTC 114 - IAT HIGHER THAN EXPECTED 2 BOSCH® TMAP

Circuit Description

The TMAP is a combined intake air temperature (IAT) and manifold absolute pressure (MAP) sensor. A temperature-sensitive resistor is used in the TMAP located in the intake manifold of the engine. It is used to monitor incoming air temperature; and the output, in conjunction with other sensors, is used to determine the airflow to the engine. The

ECM provides a voltage divider circuit so that when the air is cool, the signal reads higher voltage, and lower when warm. The IAT is a calculated value based mainly on the IAT sensor at high airflow, and influenced more by the engine coolant temperature (ECT) at low airflow. See Figure 70.

This fault will set if the intake air temperature is greater than 104.4°C (220°F) for 120 seconds and engine speed is greater than 1000 rpm. The MIL light will be on during this active fault and the engine will shut down.

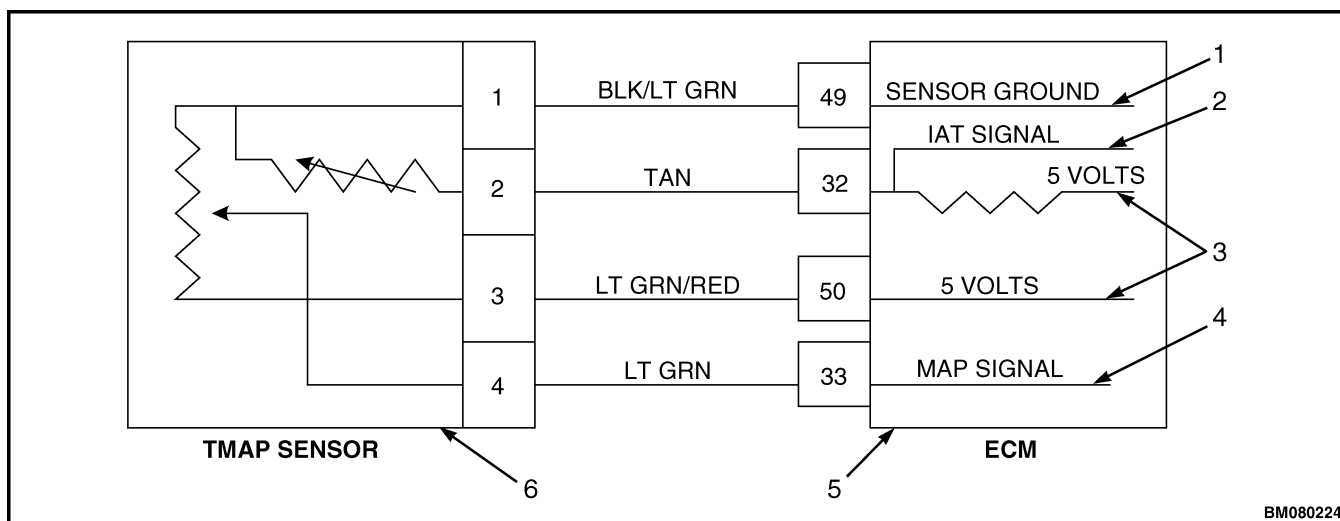

1. SENSOR GROUND
2. INTAKE AIR TEMPERATURE (IAT) SIGNAL
3. 5 VOLTS
4. MANIFOLD ABSOLUTE PRESSURE (MAP) SIGNAL
5. ELECTRONIC CONTROL MODULE (ECM)
6. TEMPERATURE MANIFOLD ABSOLUTE PRESSURE (TMAP) SENSOR

Figure 70. TMAP Sensor Circuit (Bosch® TMAP)

Conditions for Setting the DTC

- Intake air temperature.
- Check condition - engine running.
- Fault condition - intake air temperature greater than 104.4°C (220°F) for 120 seconds and engine speed is greater than 1000 rpm.
- MIL - on for active fault and for 15 seconds after active fault.
- Engine shut down.

Diagnostic Aids

This fault will set when inlet air is much hotter than normal. The most common cause of high inlet air

temperature is a problem with the inlet air system. Ensure that the air inlet is not obstructed, modified, or damaged.

Inspect the air inlet system for cracks or breaks that may allow unwanted under hood air in to the air inlet system

If none of the above can be found, follow the diagnostic steps for DTC 112 - IAT Low Voltage Bosch® TMap.

Table 121. DTC 131 - MAP High Pressure (Bosch® TMAP) (Continued)

Step	Action	Value(s)	Yes	No
10	<ul style="list-style-type: none"> • Correct TMAP mechanical connection. <p>Has TMAP mechanical connection been corrected?</p>		Go to step 11.	
11	<ul style="list-style-type: none"> • Remove all test equipment except the laptop computer. • Connect any disconnected components, fuses, etc. • Using the laptop computer, clear DTC information from the ECM. • Turn the ignition OFF and wait 30 seconds. • Start the engine and operate the vehicle to full operating temperature. • Observe the MIL. • Observe engine performance and driveability. • After operating the engine within the test parameters of DTC 131, check for any stored codes. <p>Does the engine operate normally with no stored codes?</p>		System OK.	Go to On-Board Diagnostics System Check/Malfunction Indicator Lamp.

Table 127. DTC 135 - BP Low Pressure (Bosch® TMAP) (Continued)

Step	Action	Value(s)	Yes	No
3	<ul style="list-style-type: none"> • Key OFF. • Disconnect the TMAP sensor from the wiring harness. • Using a jumper, connect the 5-volt reference pin 3 and MAP signal pin 4 together. • Key ON. <p>Does the laptop computer display BP pressure of 16.00 psia or greater?</p>		Go to step 4.	Go to step 8.
4	<ul style="list-style-type: none"> • Inspect TMAP connector and wire harness connector terminals for corrosion, contamination, or mechanical damage. <p>Did you find a problem?</p>		Repair the circuit as necessary. Refer to Wire Harness Repair. Go to step 18.	Go to step 5.
5	<ul style="list-style-type: none"> • Key OFF. • Disconnect ECM connector. • Check for continuity between TMAP sensor connector pin 4 and ECM connector pin 33. <p>Do you have continuity between them?</p>		Go to step 6.	Repair the circuit as necessary. Refer to Wire Harness Repair. Go to step 18.
6	<ul style="list-style-type: none"> • Check for continuity between TMAP sensor connector 5-volt supply pin 3 and ECM connector pin 50. <p>Do you have continuity between them?</p>		Go to step 7.	Repair the circuit as necessary. Refer to Wire Harness Repair. Go to step 18.
7	<ul style="list-style-type: none"> • Check for continuity between TMAP sensor connector ground pin 1 and ECM connector pin 49. <p>Do you have continuity between them?</p>		Go to step 17.	Repair the circuit as necessary. Refer to Wire Harness Repair. Go to step 18.
8	<ul style="list-style-type: none"> • Remove the jumper wire that was installed during step 3. • Probe TMAP connector signal circuit pin 4 with a test light connected to battery voltage. <p>Does the laptop computer display BP pressure of 16.00 psia or greater?</p>		Go to step 9.	Go to step 13.

Table 132. DTC 145 - Camshaft Sensor Noise (Continued)

Step	Action	Value(s)	Yes	No
3	<ul style="list-style-type: none"> • Key ON and engine OFF. • Disconnect the CMP sensor connector C011. • Using a DVOM, check for voltage at the CMP sensor connector pin C and engine ground. <p>Do you have voltage?</p>	5.0 volts	Go to step 4.	Repair the circuit as necessary. Refer to Wire Harness Repair. Go to step 11.
4	<ul style="list-style-type: none"> • Key OFF. • Disconnect ECM connector C001. • Using a DVOM, check for continuity between CMP connector pin A and ECM connector pin 14. <p>Do you have continuity between them?</p>		Go to step 5.	Repair the circuit as necessary. Refer to Wire Harness Repair. Go to step 11.
5	<ul style="list-style-type: none"> • Using a DVOM, check for continuity between CMP connector pin B and ECM connector pin 13. <p>Do you have continuity between them?</p>		Go to step 6.	Repair the circuit as necessary. Refer to Wire Harness Repair. Go to step 11.
6	<ul style="list-style-type: none"> • Inspect the CMP connector C011 terminals for damage, corrosion or contamination. <p>Did you find a problem?</p>		Repair the circuit as necessary. Refer to Wire Harness Repair. Go to step 11.	Go to step 7.
7	<ul style="list-style-type: none"> • Inspect the ECM connector C001 terminals 13, 14, and 50 for damage, corrosion or contamination. <p>Did you find a problem?</p>		Repair the circuit as necessary. Refer to Wire Harness Repair. Go to step 11.	Go to step 8.
8	<ul style="list-style-type: none"> • Replace CMP sensor. Pay special attention to CMP sensor reluctor wheel inspection. <p>Is the replacement complete?</p>		Go to step 10.	
9	<ul style="list-style-type: none"> • Replace the ECM. <p>Is the replacement complete?</p>		Go to step 11.	

Table 138. DTC 241 - Adaptive Lean Fault (High Limit-Gasoline) (Continued)

Step	Action	Value(s)	Yes	No
5	<ul style="list-style-type: none"> • Key OFF. • Disconnect HO₂S sensor wire harness connector. • Disconnect ECM wire harness connector. • Key ON. • Using a high impedance DVOM, check for continuity between HO₂S connector signal pin B and engine ground. <p>Do you have continuity?</p>		Repair the circuit as necessary. Refer to Wire Harness Repair. Go to step 8.	Go to step 6.
6	<ul style="list-style-type: none"> • Using a high impedance DVOM, check for continuity between HO₂S connector sensor ground pin A and signal pin B. <p>Do you have continuity?</p>		Repair the circuit as necessary. Refer to Wire Harness Repair. Go to step 8.	Go to step 7.
7	<ul style="list-style-type: none"> • Replace HO₂S sensor <p>Is the replacement complete?</p>		Go to step 8.	
8	<ul style="list-style-type: none"> • Remove all test equipment except the laptop computer. • Connect any disconnected components, fuses, etc. • Using the laptop computer clear DTC information from the ECM. • Turn the ignition OFF and wait 30 seconds. • Start the engine and operate the vehicle to full operating temperature. • Observe the MIL. • Observe engine performance and driveability. • After operating the engine within the test parameters of DTC 241, check for any stored codes. <p>Does the engine operate normally with no stored codes?</p>		System OK.	Go to On-Board Diagnostics System Check/Malfunction Indicator Lamp.

Table 145. DTC 512 - Invalid Interrupt

Step	Action	Value(s)	Yes	No
1	Did you perform the On-board diagnostics (OBD) system check?		Go to step 2.	Go to On-Board Diagnostics System Check/Malfunction Indicator Lamp.
2	<ul style="list-style-type: none"> • Key ON and engine running. • Laptop computer connected in system data mode. • Clear system fault code. Does DTC 512 reset with the engine idling?		Go to step 3.	Intermittent problem. Go to Preliminary and Intermittent Checks.
3	<ul style="list-style-type: none"> • Check all ECM power and ground circuits. Refer to GM 4.3L Wiring Schematics and Connectors. Are the power and ground circuits OK?		Go to step 4.	Repair the circuit as necessary. Refer to Wire Harness Repair. Go to step 5.
4	<ul style="list-style-type: none"> • Replace the ECM. Is the replacement complete?		Go to step 5.	
5	<ul style="list-style-type: none"> • Remove all test equipment except the laptop computer. • Connect any disconnected components, fuses, etc. • Using the laptop computer, clear DTC information from the ECM. • Turn the ignition OFF and wait 30 seconds. • Start the engine and operate the vehicle to full operating temperature. • Observe the MIL. • Observe engine performance and driveability. • After operating the engine within the test parameters of DTC 512, check for any stored codes. Does the engine operate normally with no stored codes?		System OK.	Go to On-Board Diagnostics System Check/Malfunction Indicator Lamp.

Table 153. DTC 556 - RTI 3 Loss (Continued)

Step	Action	Value(s)	Yes	No
4	<ul style="list-style-type: none"> Replace the ECM. <p>Is the replacement complete?</p>		Go to step 5.	
5	<ul style="list-style-type: none"> Remove all test equipment except the laptop computer. Connect any disconnected components, fuses, etc. Using the laptop computer, clear DTC information from the ECM. Turn the ignition OFF and wait 30 seconds. Start the engine and operate the vehicle to full operating temperature. Observe the MIL. Observe engine performance and driveability. After operating the engine within the test parameters of DTC 556, check for any stored codes. <p>Does the engine operate normally with no stored codes?</p>		System OK.	Go to On-Board Diagnostics System Check/Malfunction Indicator Lamp.

DTC 611 - FPP HIGH VOLTAGE

Circuit Description

The foot pedal position (FPP) sensor uses a variable resistor to determine signal voltage based on pedal position. Less depression of pedal results in lower voltage, and greater depression results in higher voltage.

This fault will set if voltage is over 4.8 volts for greater than 0.30 seconds with engine cranking or running. Forced idle and low rev limit will be enforced during this fault. When these are enforced,

the maximum engine speed is 1500 rpm. The low rev limit is enforced for the remainder of the key **ON** cycle. See Figure 110.

Conditions for Setting the DTC

- Foot pedal position.
- Check condition - engine cranking or running.
- Fault condition - FPP1 sensor voltage exceeds 4.8 for 0.30 seconds.
- MIL - on during active fault.
- Forced idle.
- Low rev limit.

DTC 651 - MAXIMUM GOVERN SPEED OVERRIDE

Circuit Description

- This fault will set anytime the engine rpm exceeds:
- 2700 rpm for greater than 0.100 seconds for pneumatic model trucks.
 - 3000 rpm for greater than 0.100 seconds for cushion model trucks.

This is to help prevent engine or equipment damage in the event of a governor failure. The MIL will be on during this active fault. See Figure 115.

Conditions for Setting the DTC

- Maximum govern speed override.
- Check condition - engine running.
- Fault condition - engine speed greater than specified for greater than 0.100 seconds.
- MIL - on during active fault.

Diagnostic Aids

This fault is an indication of a problem in the speed governing control system. This DTC will most likely be accompanied by other DTC codes related to the speed governing control system. Always diagnose the lowest DTC code number first in the event of multiple code sets.

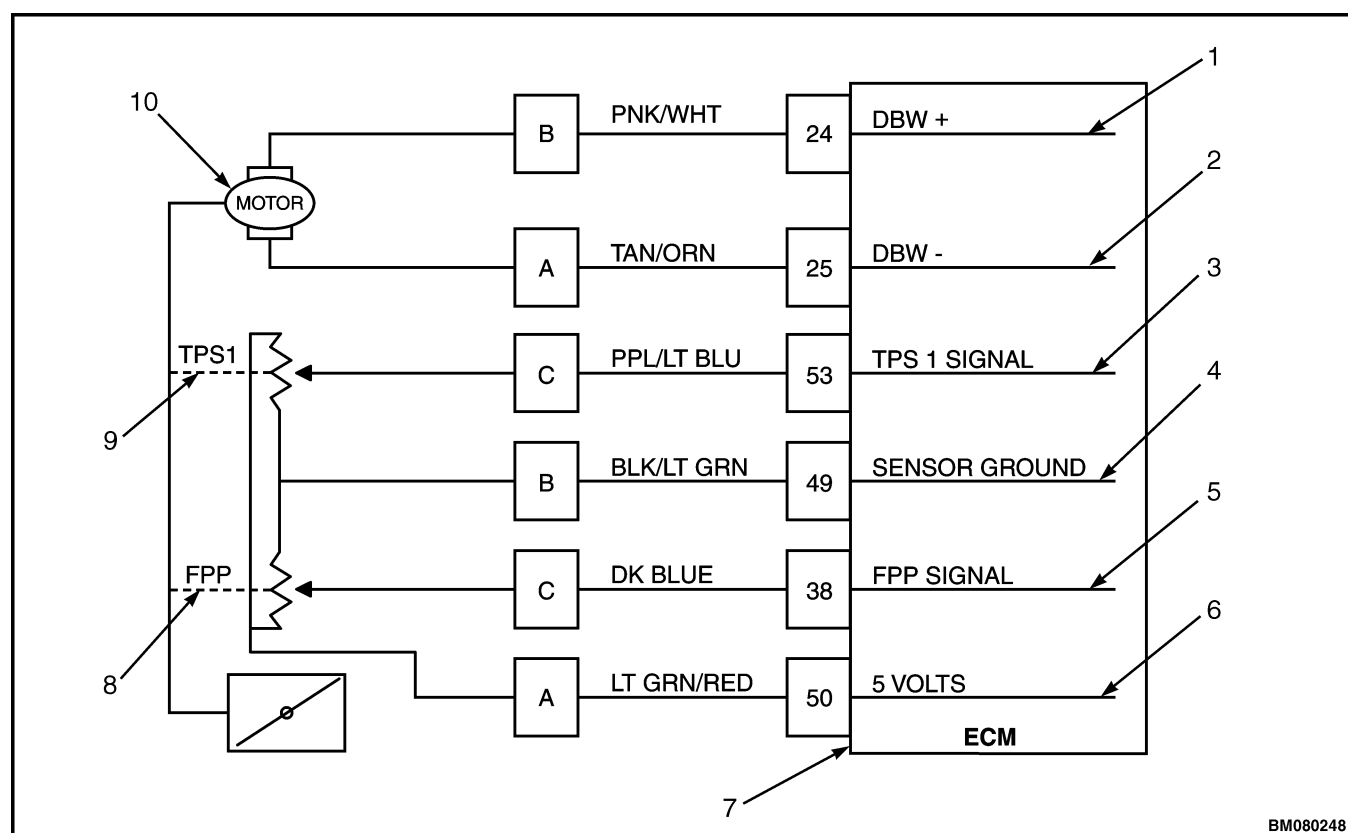

1. DRIVE BY WIRE (DBW) +
2. DRIVE BY WIRE (DBW) -
3. TPS1 SIGNAL
4. SENSOR GROUND
5. FPP SIGNAL

6. 5 VOLTS
7. ELECTRONIC CONTROL MODULE (ECM)
8. FOOT PEDAL POSITION (FPP)
9. THROTTLE POSITION SENSOR 1 (TPS1)
10. MOTOR

Figure 115. Throttle Circuit

HYSTER TECHNICAL PUBLICATIONS

Intake Air Temperature (IAT) Sensor

The IAT detects the intake air temperature to the engine. A thermistor-type sensor is used and the resistance changes according to the intake air temperature.

As shown in the characteristics graph in Figure 12, when the intake air temperature is high, the resistance is low. When the intake air temperature is low, the resistance is high.

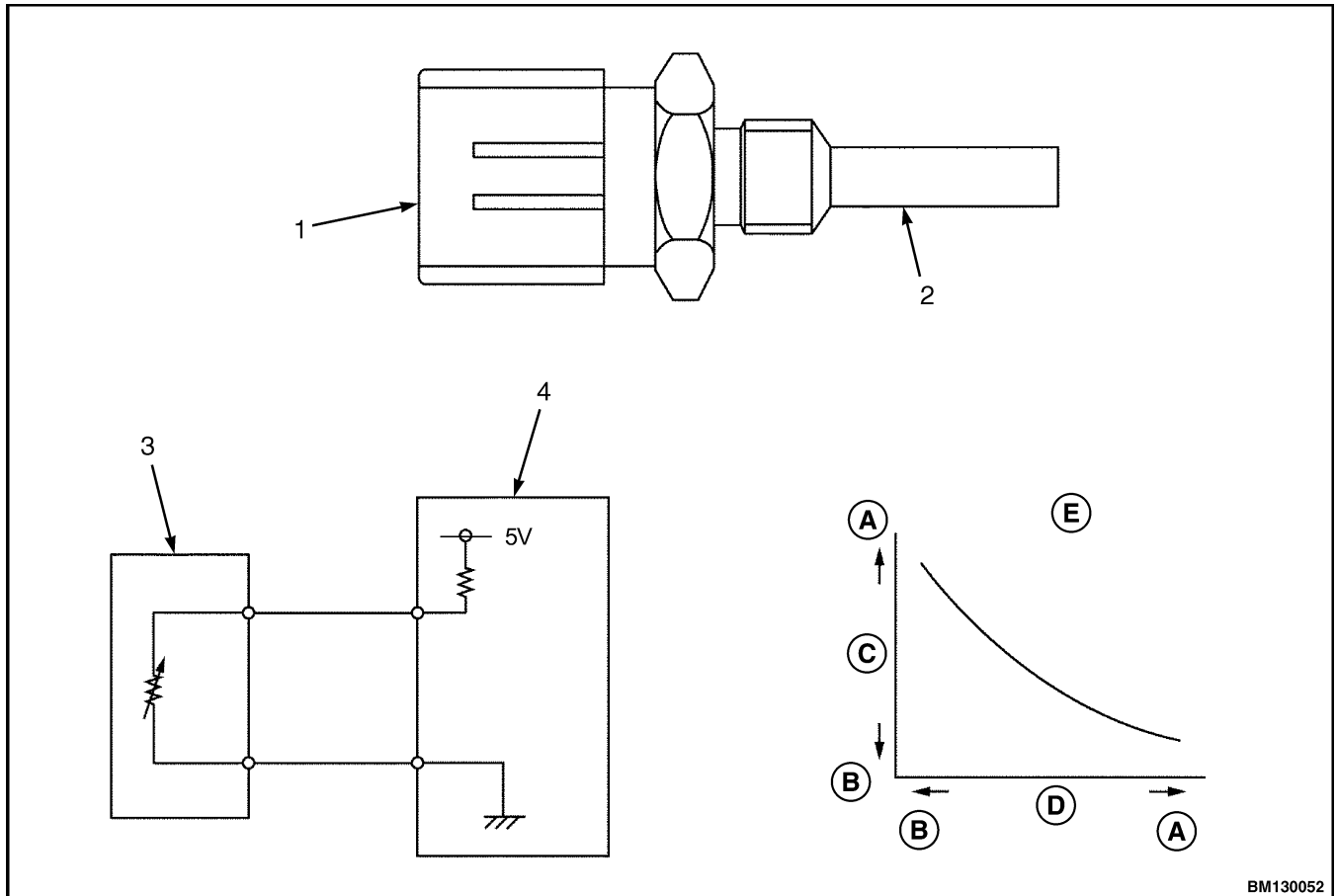

BM130052

- A. HIGH
- B. LOW
- C. RESISTANCE

- D. INTAKE AIR TEMPERATURE
- E. CHARACTERISTICS GRAPH

- 1. CONNECTOR
- 2. SENSOR

- 3. IAT SENSOR
- 4. ECU

Figure 12. Intake Air Temperature (IAT) Sensor

Service Code P0117 ECT Sensor Signals: Too Low Input Voltage to ECU

FAILURE DETECTION CONDITION

- ECU 2M terminal voltage is at below 0.20 volts.

FAIL/SAFE

- Fix the ECT for the engine control at 35°C (95°F) and the ECT for the IAC control at 80°C (176°F).
- Perform fuel cut with the engine speed at 3500 rpm or higher.

POSSIBLE SOURCES

Refer to Figure 25 for the following:

- ECT sensor failure.
- Connector or terminal failure.
- Harness of the ECT sensor A terminal and ECU 2M terminal short-circuits to ground.
- Harness between the ECT sensor A terminal and the ECU 2M terminal, and the harness between the ECT sensor B terminal and the ECU 2H terminal short-circuits.

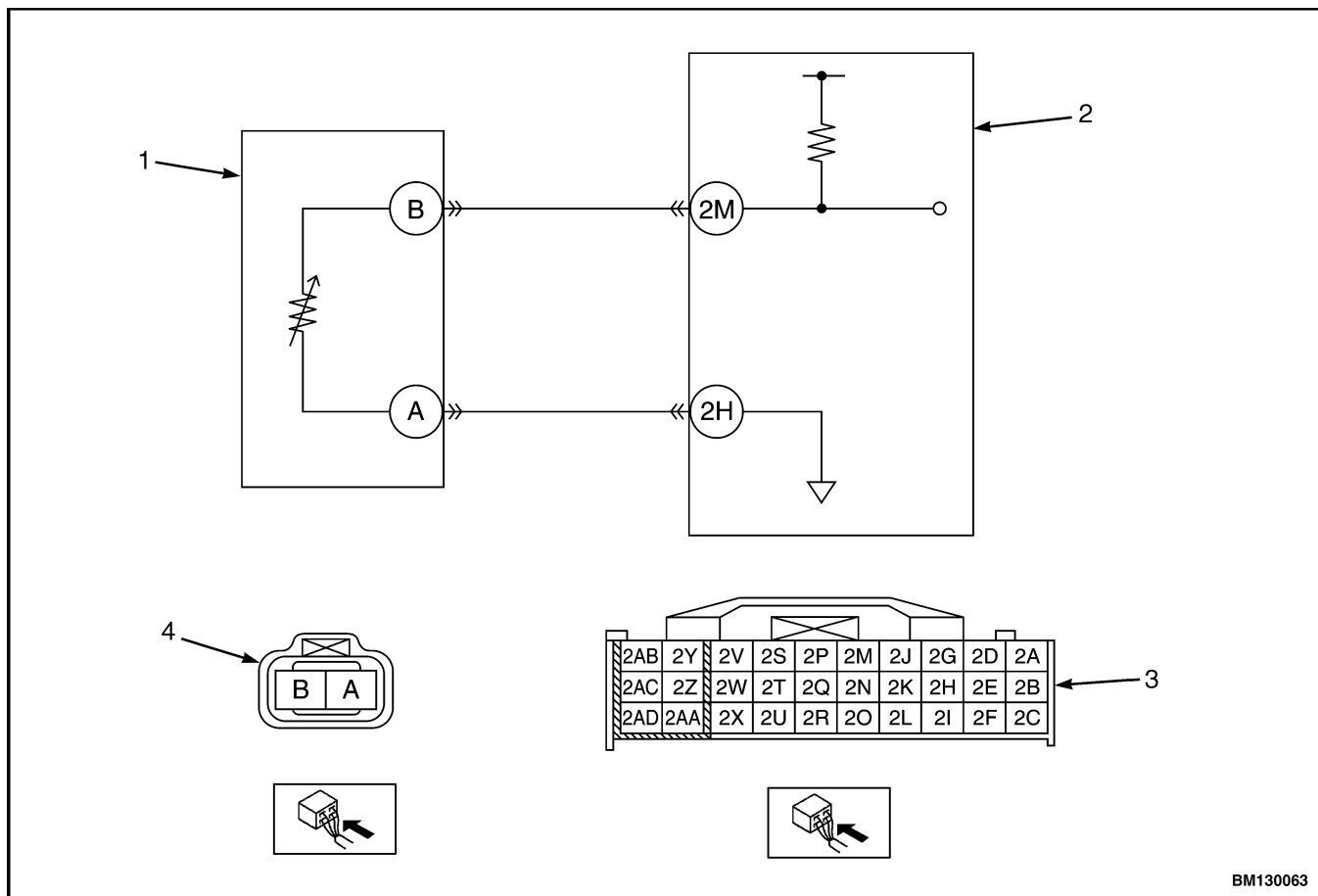

1. ECT SENSOR
2. ECU

3. CONNECTOR AT ECU HARNESS SIDE
4. CONNECTOR AT ECT SENSOR HARNESS SIDE

Figure 25. ECT Wiring Diagram

Service Code P1504 IAC System

FAILURE DETECTION CONDITION

NOTE: The threshold value depends on the battery voltage and IAC control signal duty value when detected.

- If the ECU detects that ECU 4AB terminal (IAC positive) voltage is above high-side threshold or below low-side when the IAC control duty target is above 18 percent, the ECU determines that the IAC valve circuit has a malfunction.
- If the ECU detects that ECU 4Y (IAC negative) voltage is above 2 volts, or IAC control duty target is below threshold (according to battery voltage), the ECU determines that the IAC valve circuit has a malfunction.

POSSIBLE SOURCES

Refer to Figure 33 for the following:

- IAC valve circuit failure.
- Connector or terminal failure.
- Harness between the IAC valve A terminal and ECU 4AB terminal short-circuits to ground.
- Harness breakage between the IAC valve A terminal and ECU 4AB terminal.
- Harness between the IAC valve B terminal and ECU 4Y terminal short-circuits to ground.
- Harness between IAC valve B terminal and ECU 4Y terminal short-circuits to power supply system.
- Harness breakage between the IAC valve B terminal and ECU 4Y terminal.
- ECU failure.

FAIL/SAFE

Stops IAC.

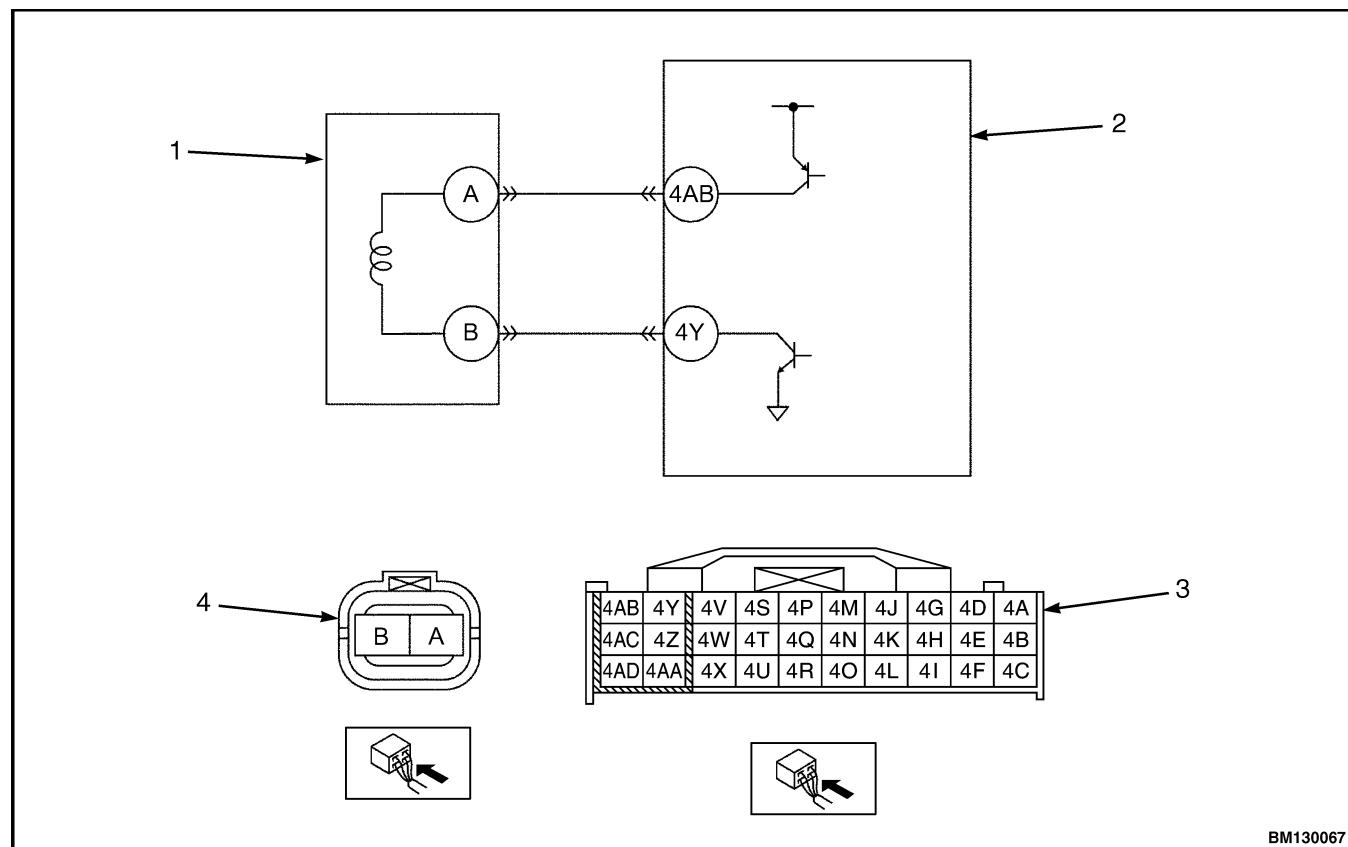

BM130067

1. IAC VALVE
2. ECU

3. CONNECTOR AT ECU HARNESS SIDE
4. CONNECTOR AT IAC VALVE SIDE

Figure 33. IAC Valve Wiring Diagram

5. Remove the pressure regulator.
6. Remove and discard the O-ring.

Install

1. Apply a light coat of engine oil to the new O-ring and install the O-ring.
2. Place the pressure regulator in position and install the two capscrews. Tighten the capscrews to 7.9 to 10.7 N•m (69.5 to 95.4 lbf in).
3. Connect the vacuum hose to the pressure regulator.
4. Connect the negative battery cable.
5. Complete the After Repair Procedure.

Operation Check

NOTE: Carry out the Fuel Line Pressure Check. If not as specified, perform the following procedures for the pressure regulator.

1. Complete the Before Repair Procedure.
2. Disconnect the negative battery cable.
3. Connect a fuel pressure gauge between the fuel filter and the fuel distributor.
4. Connect the negative battery cable.
5. Start the engine and let it idle.
6. Measure the fuel line pressure after approximately 2 minutes.
Specification: 200 to 240 kPa (29 to 35 psi)
7. Disconnect the vacuum hose from the pressure regulator and measure the fuel line pressure.
Specification: 260 to 310 kPa (37 to 45 psi)
8. If not as specified, inspect the following:
 - a. Fuel pump pressure
 - b. Fuel filter for clogging
 - c. Fuel injector for leakage
 - d. Circuit relay
 - e. Fuel line for improper routing, clogging, kinks or leakage
9. If all items in Step 8 are okay, replace the pressure regulator.
10. Turn the ignition switch to **LOCK**.
11. Complete the After Repair Procedure.

Exhaust System

EXHAUST SYSTEM, INSPECT

Start the engine and inspect the exhaust system component for exhaust gas leakage. If leakage is found, repair or replace components as necessary.

THREE WAY CATALYTIC (TWC) CONVERTER

Remove and Install



WARNING

When the engine and exhaust system are hot, they can cause severe burns. Turn off the engine and wait until they are cool before removing the exhaust system.

1. Refer to the section **Frame** 100 SRM 505 for the removal and installation of the TWC.

EXHAUST MANIFOLD

Remove



WARNING

When the engine and exhaust system are hot, they can cause severe burns. Turn off the engine and wait until they are cool before removing the exhaust system.

1. Disconnect the negative battery cable.
2. Remove the three capscrews retaining the exhaust manifold insulator and remove the insulator. See Figure 48.
3. Remove the four nuts and washers retaining the exhaust pipe to the exhaust manifold.

Table 29. Troubleshooting

Troubleshooting Item		Description	Possible Cause
Will not crank		Starter does not work.	1, 2, 4, 8, 12
Hard to start/long crank/erratic start/erratic crank		Starter cranks engine at normal speed but engine requires excessive cranking time before starting.	21, 23, 24, 27, 30, 31, 32, 33, 34, 35, 38, 40, 41, 43, 47
Engine stalls	After start/at idle	Engine stops unexpectedly at idle and/or after start.	6, 7, 8, 21, 22, 23, 24, 25, 27, 28, 29, 30, 31, 32, 33, 34, 35, 36, 37, 40, 41, 43, 45, 51
Crank normally but will not start		Starter cranks engine at normal speed but engine will not run.	6, 7, 8, 21, 22, 24, 25, 27, 28, 29, 30, 31, 32, 33, 34, 35, 36, 37, 40, 41, 43, 44, 45
Slow return to idle		Engine takes more time than normal to return to idle speed.	26, 46
Engine runs rough/rolling idle		Engine speed fluctuates between specified idle speed and lower speed and engine shakes excessively.	6, 7, 21, 22, 24, 25, 27, 29, 30, 31, 32, 33, 34, 35, 36, 38, 39, 40, 41, 43, 51
Fast idle/runs on		Engine speed continues at fast idle after warm-up. Engine runs after ignition switch is turned off.	20, 46
Low idle/stalls during deceleration		Engine stops unexpectedly at beginning of deceleration or recovery from deceleration.	24, 25, 40, 47, 48, 49
Engine stalls/quits	Acceleration/cruise	Engine stops unexpectedly at beginning of acceleration or during acceleration. Engine stops unexpectedly while cruising.	6, 7, 21, 22, 23, 24, 26, 27, 30, 32, 33, 34, 35, 36, 38, 39, 40, 41, 43, 44, 45, 47, 48, 49, 51
Engine runs rough	Acceleration/cruise	Engine speed fluctuates during acceleration or cruising.	6, 7, 21, 22, 23, 24, 26, 27, 30, 32, 33, 34, 35, 36, 38, 39, 40, 41, 43, 44, 45, 47, 48, 49, 50, 51
Misses	Acceleration/cruise	Engine misses during acceleration or cruising.	6, 7, 21, 22, 23, 24, 26, 27, 30, 32, 33, 34, 35, 36, 38, 39, 40, 41, 43, 44, 45, 47, 48, 49, 51

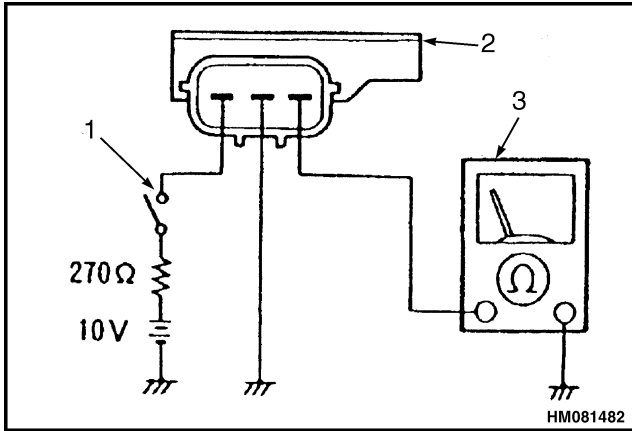

- 1. SWITCH
- 2. IGNITER
- 3. OHMMETER

Figure 4. Igniter Test Connections

INSTALL

NOTE: Coat the new O-ring and the gear on the distributor with clean engine oil.

1. Install a new O-ring, coated with clean engine oil, into the engine. See Figure 2.

CAUTION

If the engine crankshaft has been moved since the distributor was removed, see the repair procedures for the engine to correctly install the distributor. Do NOT do Step 2.

2. Make sure the alignment marks on the engine and the distributor housing are properly aligned. Install the distributor into the engine without turning the distributor housing. Install the distributor mounting bolt and tighten to 19 to 25 N•m (14 to 18 lbf ft). See Figure 2.
3. Connect the cable connector to the side of the distributor. See Figure 2.
4. Connect the spark plug wires to the distributor cap. See Figure 2.

Ignition Coil Check

PRIMARY COIL WINDING

Using an ohmmeter connected to the ignition coil as shown in Figure 5, measure the resistance of the primary coil. The resistance should be 0.81-0.99Ω at 20°C (68°F). If the resistance is not within the specifications, replace the ignition coil.

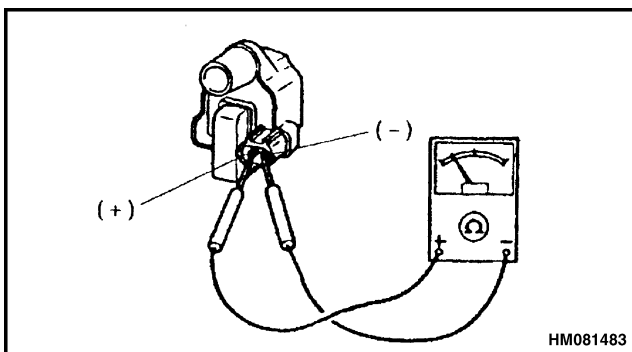

Figure 5. Primary Coil Check

SECONDARY COIL WINDING

Using an ohmmeter connected to the ignition coil as shown in Figure 6, measure the resistance of the secondary coil. The resistance should be 10.4-15.6Ω at 20°C (68°F). If the resistance is not within the specifications, replace the ignition coil.

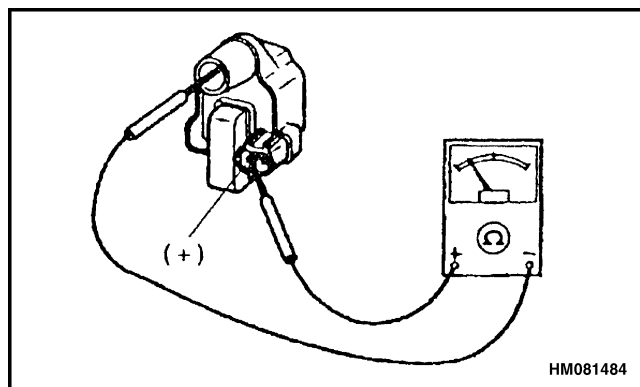
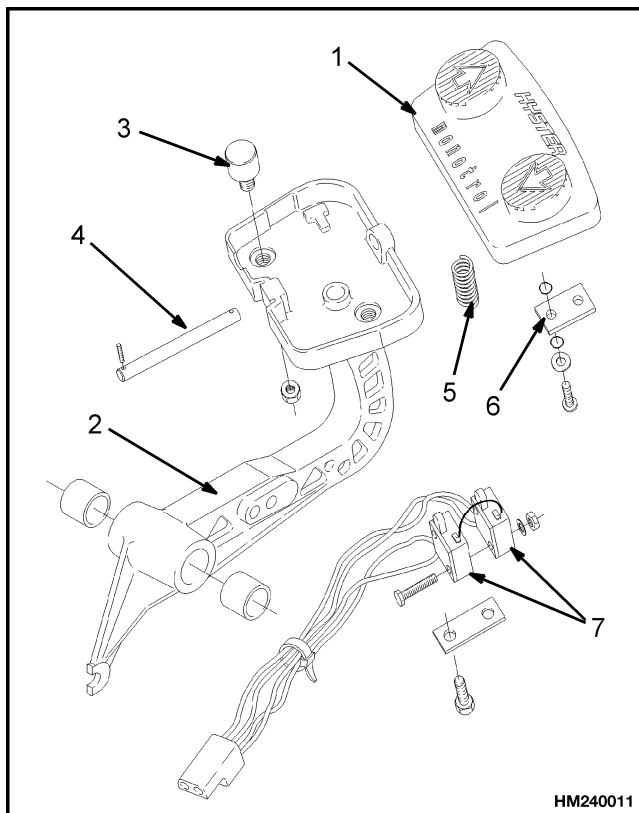

Figure 6. Secondary Coil Check

MONOTROL Pedal Start Circuit

A switch in the hand lever for the parking brake supplies electrical power to the MONOTROL pedal. The MONOTROL pedal energizes the solenoid valves. When the hand lever for the parking brake is in the released position, the switch in the hand lever is closed so that electric power is supplied to the MONOTROL pedal. The forward and reverse solenoid valves are controlled by the MONOTROL pedal. When the hand lever for the parking brake is in the applied position, the switch is open so that both of the solenoid valves close. When both of the solenoid valves close (de-energize), the centering spring moves the direction spool to the Neutral position.



- | | |
|----------------|-----------------|
| 1. PEDAL PAD | 5. SPRING |
| 2. PEDAL FRAME | 6. MAGNET PLATE |
| 3. MAGNET | 7. SWITCH |
| 4. PIVOT SHAFT | |

Figure 13. MONOTROL Pedal

A switch in the hand lever for the parking brake energizes and de-energizes the start circuit on the ignition switch. When the hand lever for the parking brake is in the applied position, the start circuit can be energized so that the lift truck can be

started. When the hand lever for the parking brake is in the released position, the start circuit is de-energized and the engine cannot be started.

When the inching/brake pedal is fully pushed down, the service brakes are applied and a disc on the end of the inching spool actuates the neutral start switch. The neutral start switch is in series electrically with a pressure switch in the brake system. The disc actuates the neutral start switch, and the pressure in the brake system closes the brake switch. The pressure switch in the brake system makes sure the brakes are applied. When the neutral start switch and the brake switch are both closed, the start circuit, controlled by the ignition switch, can be energized. When the inching/brake pedal is fully pushed down, oil pressure to the clutch pack is reduced to zero. This operation makes sure the transmission clutch is disengaged and the brakes are applied when the engine is started.

DIRECTION CONTROL LEVER

The direction control lever is used to control the operation of the direction solenoids. See Figure 14. When the lift truck has a direction control lever, an accelerator pedal is used to control the speed of the engine. The control lever actuates four switches. In the Neutral position, all of the switches are closed. The lever must be in this position to start the lift truck. When the lever is moved to the Forward position, the forward switch is open and the reverse switch is closed. In this position the forward solenoid is energized. In the Reverse position, the reverse switch is open and the forward switch is closed, energizing the circuit for the reverse solenoid.

DIFFERENTIAL

The ring and pinion gears transfer power to the axle shafts at right angles to the transmission. The ring and pinion is also a gear reduction which increases the torque to the drive wheels. The differential assembly permits the drive wheels to turn at different speeds when the lift truck is turning a corner. See Figure 15.

The ring and pinion gears are held in position in the transmission case by the differential housing. The housing for the drive axle is fastened to the differential housing. The output gear for the transmission is installed on the pinion shaft. The output gear is in constant mesh with the gears of the Input (forward) and Counter (reverse) clutch hubs.

INTRODUCTION

GENERAL

This section has the description, operation and the repair procedures for the parts of the LPG fuel system used on the GM 2.2L and 3.0L engines.

DESCRIPTION AND OPERATION

The LPG fuel system has a fuel tank, solenoid valve, relief valve, fuel filter and fuel valve, vaporizer, carburetor, governor controller and governor assembly. See FIGURE 1.

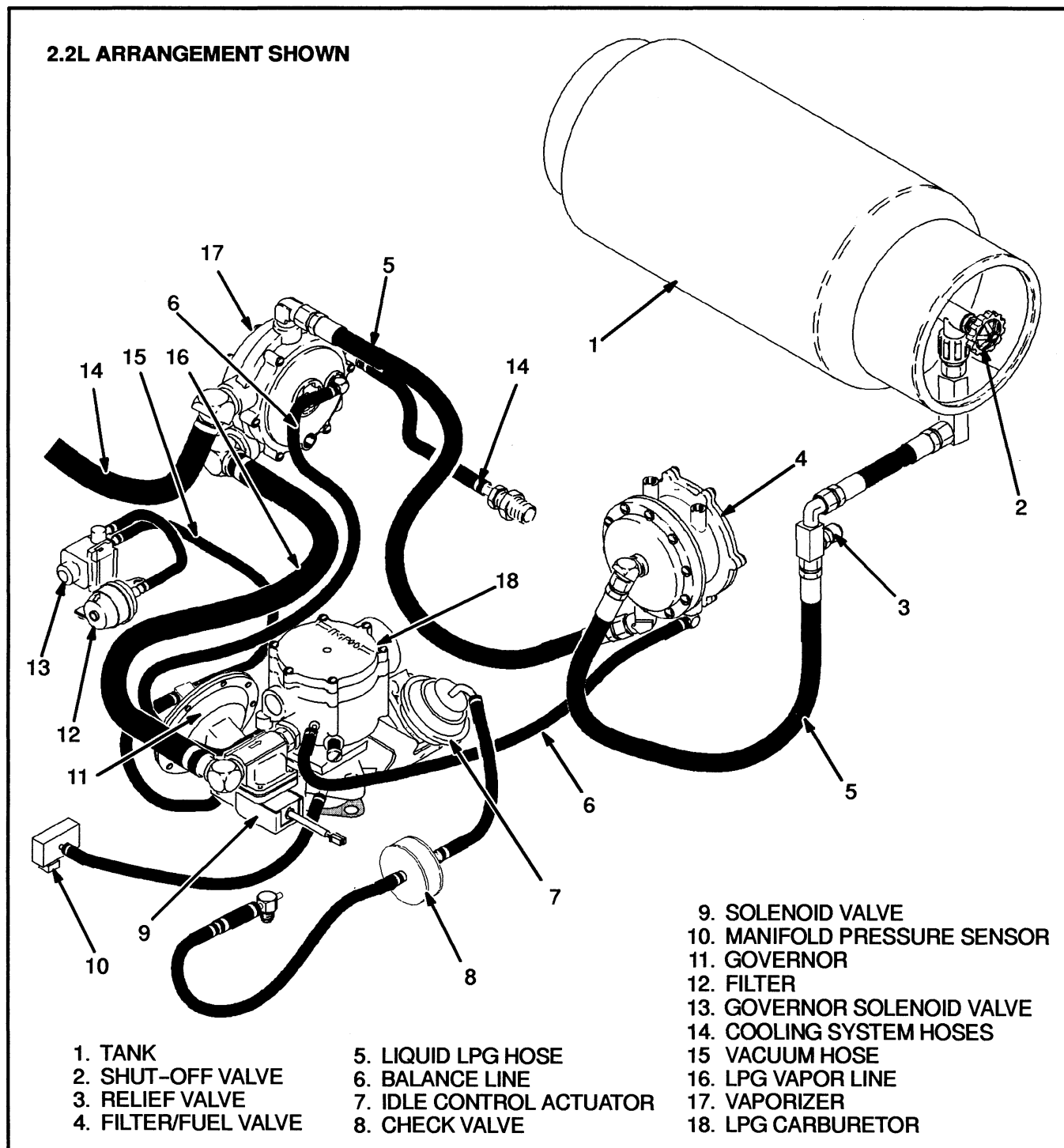

FIGURE 1. ARRANGEMENT FOR GM 2.2L ENGINE

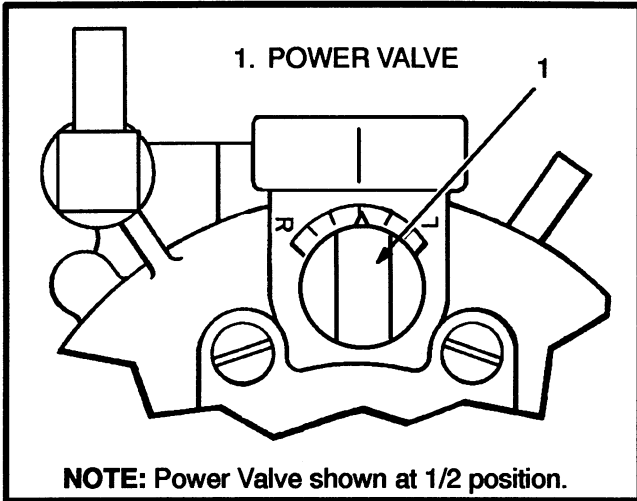

FIGURE 17. POWER MIXTURE ADJUSTMENT

CAUTION

During this test the mast must be fully extended. Make sure there is enough overhead clearance in the building or do the test outdoors.

1. Operate the lift truck until the engine, transmission and hydraulic system are at normal operating temperatures. Apply the parking brake.
2. Install an exhaust gas analyzer in the exhaust pipe. Connect a tachometer to the engine. Start the engine and fully extend the mast. Pull back on the LIFT lever to put a load on the engine. Fully depress the accelerator pedal

and turn the power mixture valve until the reading on the exhaust gas analyzer is 0.5 to 1.0% CO (carbon monoxide) maximum.

ADJUST THE THROTTLE LINKAGE
(See FIGURE 18.)

CAUTION

The adjustment of the throttle cable must be correct or the cable can break during operation. The accelerator pedal or the MONOTROL pedal must reach the pedal stop (floor plate) by the time the throttle plate in the carburetor is fully open.

NOTE: Each time the throttle system is disassembled, it is important to adjust the throttle cable.

1. Adjust the idle speed as described in Idle Speed Adjustment.
2. Make sure the throttle linkage at the pedal assembly is in the correct position.
3. Push the Monotrol or throttle pedal until it stops against the floor plate. Adjust the throttle cable so that the pedal stops against the floor plate. Depress the throttle pedal until it stops against the floor plate just as the throttle plate reaches the wide open position. Use the nuts at the pedal end of the cable housing to change the adjustment of the cable.

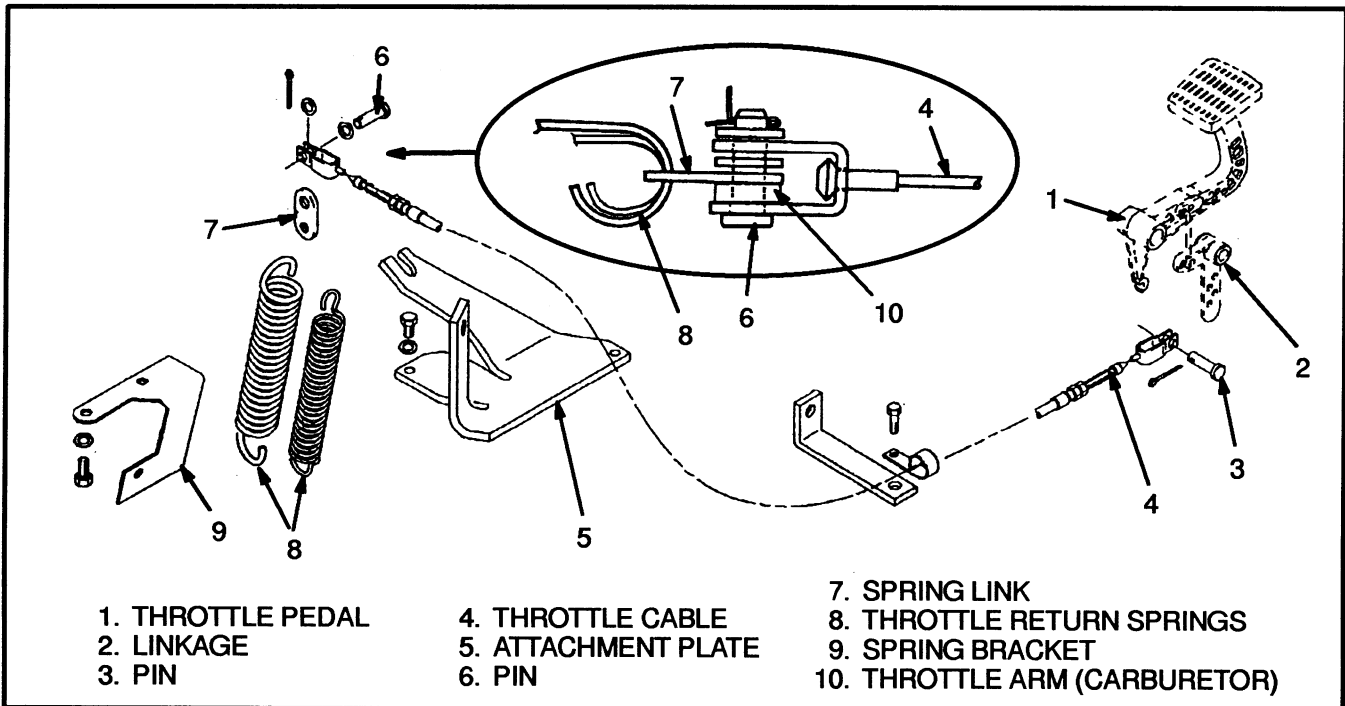

- | | | |
|-------------------|---------------------|-------------------------------|
| 1. THROTTLE PEDAL | 4. THROTTLE CABLE | 7. SPRING LINK |
| 2. LINKAGE | 5. ATTACHMENT PLATE | 8. THROTTLE RETURN SPRINGS |
| 3. PIN | 6. PIN | 9. SPRING BRACKET |
| | | 10. THROTTLE ARM (CARBURETOR) |

FIGURE 18. THROTTLE CABLE ARRANGEMENT

6. Remove the pivot pin at the float. Remove the float and the inlet valve. Be careful when removing the float from the inlet body. If the tabs on the float are bent during removal, the float will not be adjusted correctly. Remove the inlet valve seat from the air horn.

7. Remove the three screws from the cover of the choke release mechanism. Carefully remove the cover and the return spring. Remove the diaphragm and lever.

8. Remove the idle compensator valve from the float

bowl housing.

9. Carefully lift the outlet nozzle for the accelerator pump and the retainer for the nozzle from the slot in the float bowl housing. Remove the spring and the check ball from the bore.

10. Remove the slow speed jet from the float bowl housing. Remove the float chamber plug and washer to reach the main jet. Remove the main jet and washer from the float bowl housing.

**"THE
QUALITY
KEEPERS"**

**HYSTER
APPROVED
PARTS**

INTRODUCTION

GENERAL

This section has the description, operation and the repair procedures for the parts of the LPG fuel system used on the MAZDA M4-2.0G engine.

DESCRIPTION AND OPERATION.

The LPG fuel system has a fuel tank and valve, hydro-

static relief valve, fuel filter and fuel valve unit, vaporizer, carburetor, solenoid valve, fuel pressure sensor and indicator lamp, and a governor. The LPG arrangement for the S/H1.50-1.75XM, S/H2.00XMS (S/H25-35XM, H40XMS) units is shown FIGURE 1. The LPG arrangement for the S/H2.00-3.20XM (S/H40-65XM) units is shown FIGURE 2.

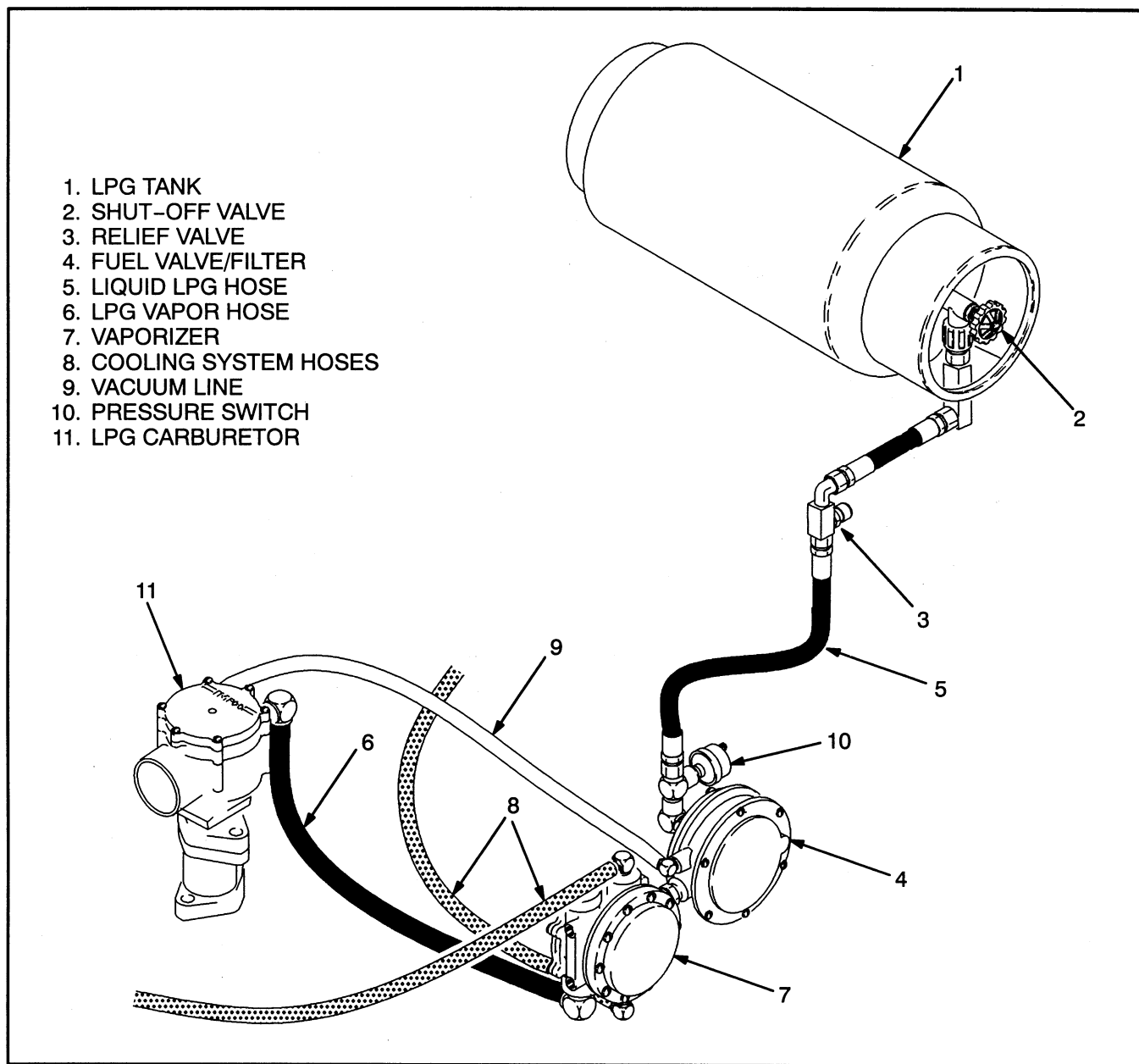

FIGURE 1. LPG SYSTEM, S/H1.50-1.75XM, S/H2.00XMS (S/H25-35XM, H40XMS)

ADJUST THE CARBURETOR

Idle Mixture (See FIGURE 19.)

1. When the engine is not running, turn the idle mixture screw clockwise until it stops. In this position, the idle mixture screw prevents air from entering the air tube through the idle air port.
2. Turn the idle mixture screw four turns counterclockwise.
3. Start the engine and run until warm. Adjust the mixture screw clockwise (up to 2 full turns) as needed until the idle is smooth. Turning the screw clockwise increases the ratio of fuel to air.

Idle Adjustments (See FIGURE 19.)

NOTE: Only the H2.00–3.20XM (H40–65XM) units use the idle control actuator.

1. The engine must be at the normal operating temperature. Connect a tachometer to the engine.
2. Turn the idle speed screw until the idle speed of the engine is 725 ± 25 rpm.
3. Turn the idle mixture screw (2) $4 \frac{1}{2} \pm \frac{1}{2}$ turns from the full IN position. Check and adjust the idle speed as necessary.
4. Check the idle control adjustment as follows:
 - a. Adjust the idle speed and mixture as described above.
 - b. Put the transmission in NEUTRAL and disconnect the vacuum hose from the idle control actuator (4). Put a plug in the vacuum hose. Adjust the engine idle speed to 1400 ± 50 rpm with the idle control screw (3).
 - c. Install the vacuum hose and clamp to the idle control actuator (4).
 - d. Check the idle speed. If the idle speed is higher than specifications, make the adjustment at the idle control screw (3).

5. Check that the engine runs at its governed speed when the accelerator pedal or the MONOTROL pedal reaches the floor plate. If necessary, adjust the throttle cable at the bracket on the engine. Loosen the lock nuts and move the cable as necessary. Check that the maximum engine speed is 2600 to 2700 rpm.

CAUTION

The adjustment of the throttle cable must be correct or the cable can break during operation. The accelerator pedal or the MONOTROL pedal must reach the pedal stop (floor plate) by the time the throttle plate in the carburetor is fully open.

Power Mixture Adjustment (See FIGURE 19.)

The power mixture valve controls the flow of fuel to the carburetor when the engine is running near full load. Set the power mixture valve on the center notch. This setting will be correct for most conditions. If further adjustment is needed, the engine speed must not be permitted to increase to the governor limit.

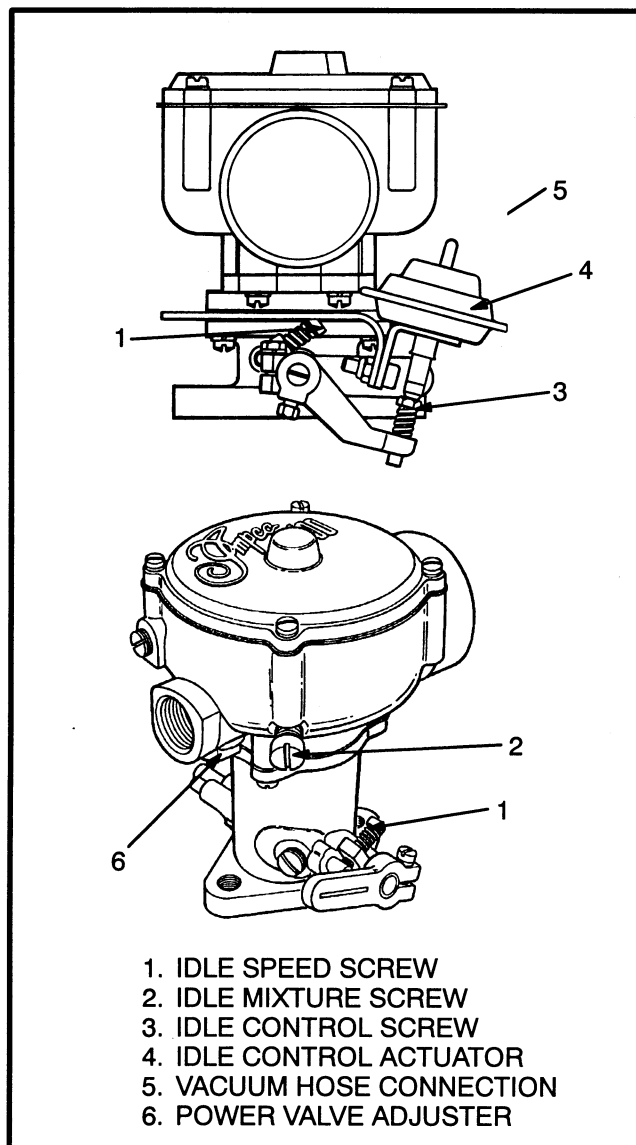

FIGURE 19. LPG CARBURETOR

TABLE 2. "SCAN" TOOL INFORMATION

Test under following conditions: Idle speed, upper radiator hose hot, throttle closed, NEUTRAL, all accessories "OFF"		
"SCAN" Position	Units Displayed	Values
Engine Speed	rpm	+100 rpm from
Idle Speed	rpm	ECM idle command (changes with temperature)
Coolant Temp.	°C /°F	85 to 100°C/180° to 212°F
Ignition Volts	volts	12.5 to 14.5 v
MAP	Volts/kPa	1 to 2 (depends on Vac. and BARO press.), 30–40 kPa
BARO	Volts/kPa	1 to 2 (depends on BARO pressure), 98–102 kPa
Throttle Position	volts	.45 to 1.25 v
Throttle Angle	0 to 100%	0
Governor TPS	0 to 100%	0
Desired Governor TPS	0 to 100%	0
Governor Enable	Yes/No	Yes
Governor rpm Control	Active/Not Active	Not Active
Governor rpm Mode	High rpm/Normal	Normal
Idle Air Control	Counts/Steps	Between 5 and 50
rpm Overspeed	Yes/No	No
Fuel Trim	Steps	N/A
Injector Pulse Width	MSec	.8 to 3.0 mSEC
Spark Advance	No. of Degrees	Varies
Base Timing	N/A	N/A
Knock Signal	Yes/No	No
Knock Retard	No. of Degrees	0 Degrees
Governor mph Control	Active/Not Active	Not Active
Vehicle Speed	mph	0 mph
mph Overspeed	Yes/No	No
Low Oil Pressure	Yes/No	No
Power Steering Switch	Normal/High	Normal
Emergency Stop	Active/Not Active	Not Active
Lift Mode	Active/Not Active	Not Active
EEPROM ID	number	XXXX (varies with calibration) – 2201
Time From Start	hrs., min., sec.	0:00:00 – 18:12:15

Other Troubleshooting Checks:

Fuel system pressure that is not correct can cause one of the following symptoms:

- Cranks, but will not start.
- Starts, but will not continue to run.

- Long cranking times before engine starts.
- Rough idle or low idle speed.
- Engine miss, feels like ignition problem.
- High fuel usage, loss of power, poor performance.

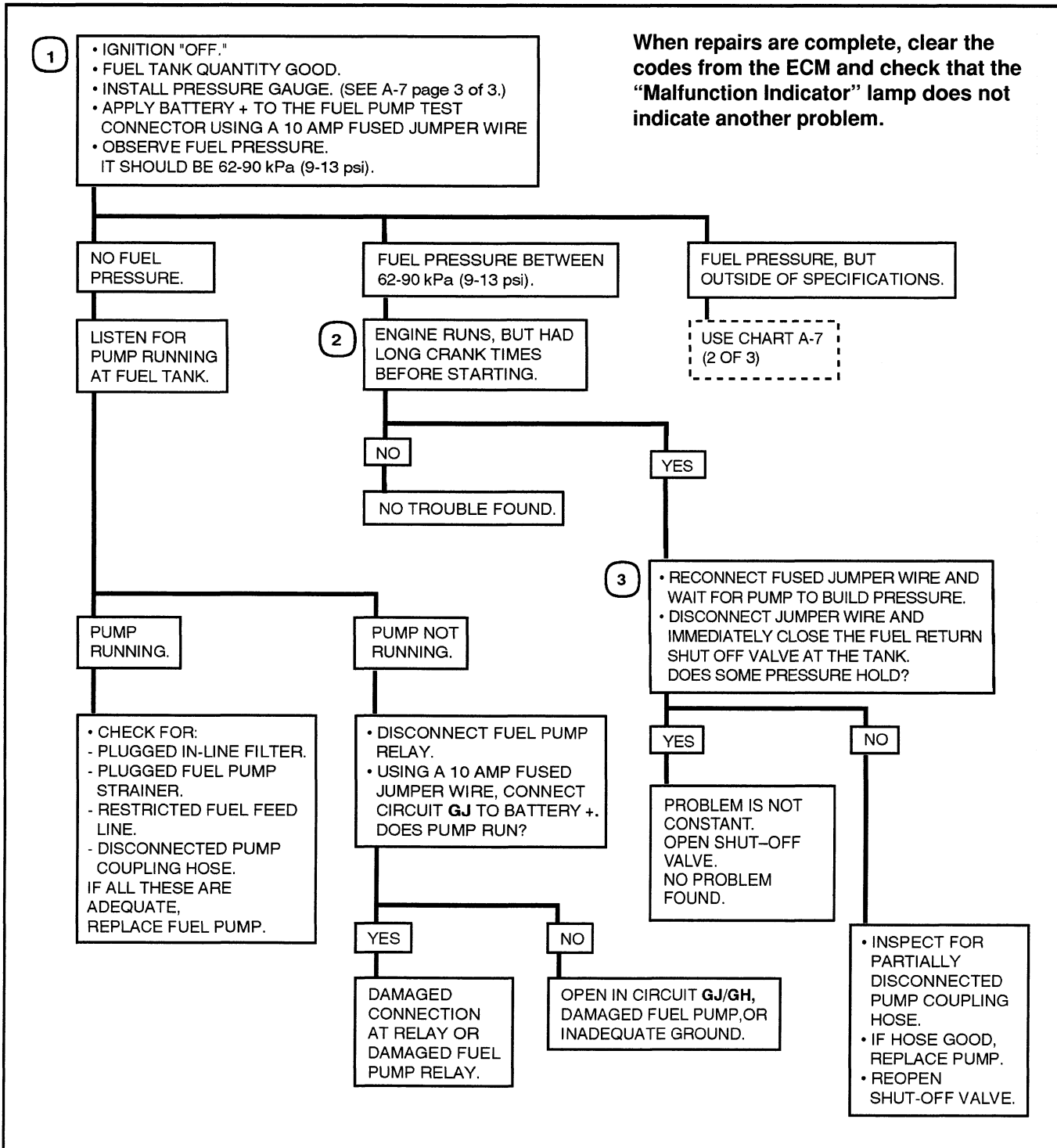
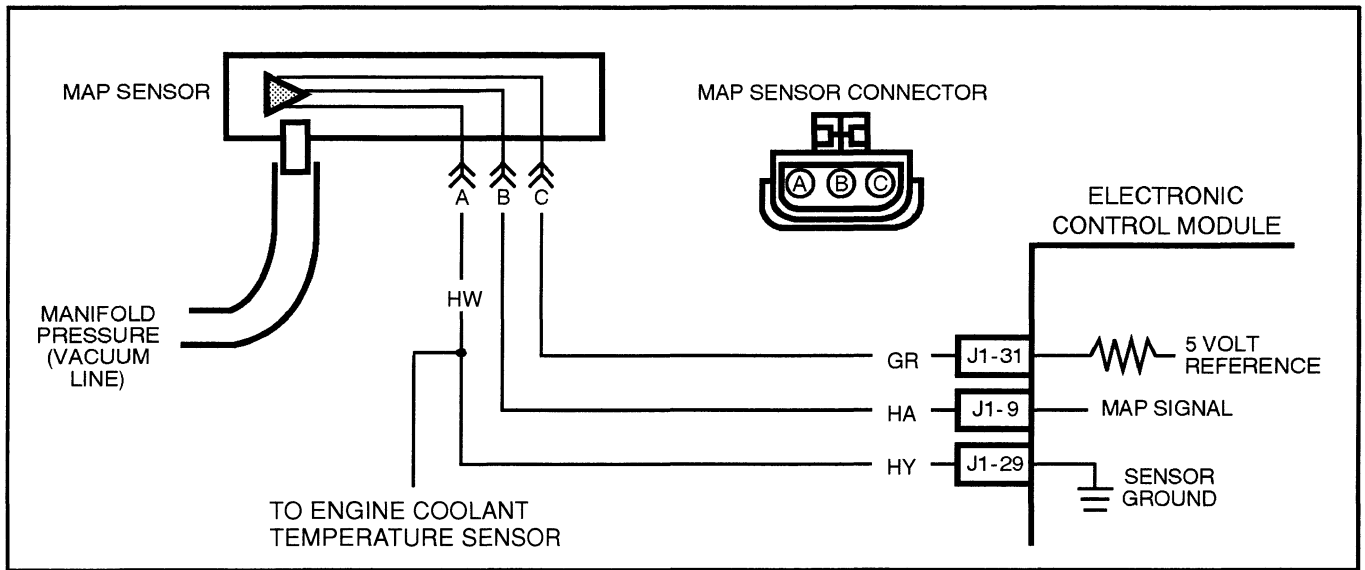

CHART A-7 – FUEL SYSTEM TROUBLESHOOTING (1 of 3)



DTC 33 MANIFOLD ABSOLUTE PRESSURE (MAP) SENSOR CIRCUIT (SIGNAL VOLTAGE HIGH – LOW VACUUM)

CIRCUIT DESCRIPTION

The Manifold Absolute Pressure (MAP) sensor responds to changes in manifold pressure (vacuum). The ECM receives this information as a signal voltage that will vary from about 1 to 1.5 volts at closed throttle idle, to 4 to 4.5 volts at wide open throttle (low vacuum). If the MAP sensor fails, the ECM will use a fixed MAP value and use the Throttle Position (TP) Sensor to control fuel delivery.

Test Description: The number(s) below are a reference to number(s) in circles in the troubleshooting chart on the next page.

1. This step will determine if DTC 33 is caused by a current failure or a condition that is not constant.

- A DTC 33 will set if:
 - MAP signal is more than 90 kPa (low manifold vacuum),
 - TP Sensor less than 5%,
 - These conditions for a time longer than 10 seconds.

2. This step causes the conditions for a DTC 34. If the ECM sees the change, the ECM and circuits HA and HY/HW are good.

3. See SYSTEM TEST CHARTS for complete test of MAP sensor.

Other Troubleshooting Checks:

- With the ignition ON and the engine stopped, the manifold pressure is equal to atmospheric pressure and the signal voltage will be high. This information is used by the ECM as an indication of vehicle altitude and is referred to as BARO. Comparison of this BARO reading with a known good vehicle with the same type sensor is a good way to check accuracy of a sensor. Correct readings will be within .4 volt of each other.
- A DTC 33 occurs if either circuit HW/HY is open, or if circuit GR has a short to voltage or to circuit HA.
- If HW is open, DTC 33 and DTC 15 will set.
- If DTC 33 is not constant, see TROUBLESHOOTING – POOR OPERATION.

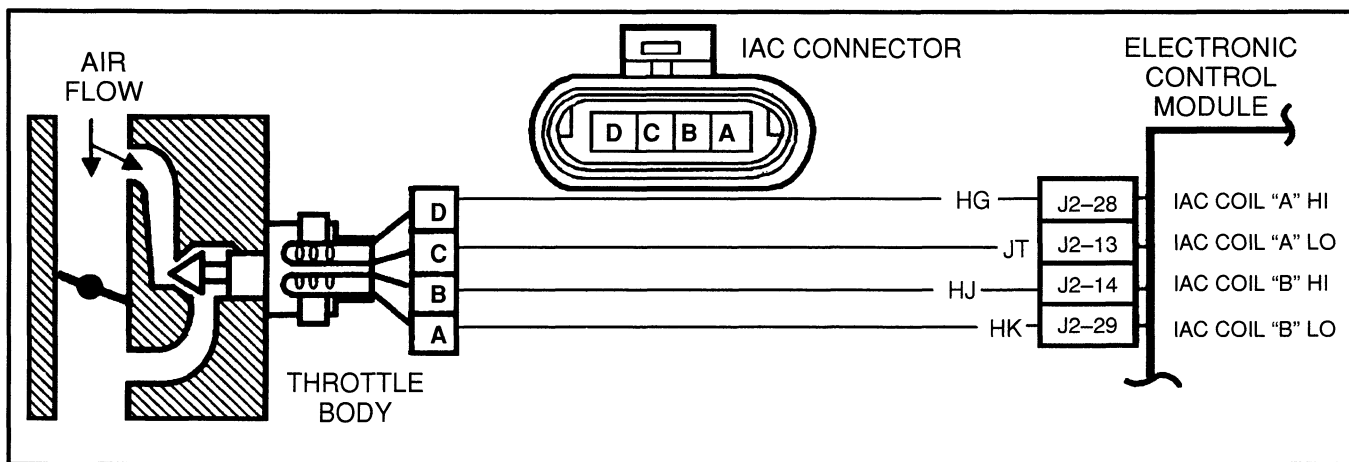

CHART C-1
IDLE AIR CONTROL (IAC) SYSTEM CHECK

CIRCUIT DESCRIPTION

The ECM controls engine idle speed with the IAC valve. To increase idle speed, the ECM retracts the IAC valve pintle away from its seat, allowing more air to bypass the throttle bore. To decrease idle speed, the IAC valve pintle extends towards its seat, reducing by-pass air flow. A "SCAN" tool will read the ECM commands to the IAC valve in counts. The higher the counts indicate more air bypass (higher idle). The lower the counts indicate less air is allowed to bypass (lower idle).

Other Troubleshooting Checks:

- A slow, unstable, or fast idle speed can be caused by a problem other than the IAC system. Out of control range IAC "SCAN" tool counts will be above 50 if idle is too low, and zero counts if idle is too high. Make the following checks to repair a problem that is not in the IAC system:
- Vacuum Leak (High Idle) – If idle is too high, stop the engine. Fully extend (low) IAC with tester. Start engine. If idle speed is above 800 RPM, fix vacuum leak including PCV system. Also check for smooth movement of the throttle plate or linkage.
- PCV Valve – If a high idle condition exists (800 to 1000 RPM), check for vacuum leaks and correct PCV valve operation. All throttle bodies are pre-set at the factory and do not need adjustment. A missing PCV valve or grommet or a valve that sticks can cause this condition.
- System Too Lean (High Air/Fuel Ratio) – The idle speed can be too high or too low. Engine speed can vary up and down and disconnecting the IAC valve does not help. Check for low fuel pressure, water in the fuel or a dirty injector.
- System Too Rich (Low Air/Fuel Ratio) – The idle speed will be too low. "SCAN" tool IAC counts will usually be above 50. System is rich and can cause black smoke in exhaust. Check for high fuel pressure or an injector that leaks or sticks.
- Throttle Body – Remove IAC valve and inspect bore for dirt.
- IAC Valve Electrical Connections – Check IAC valve connections for correct contact.
- See TROUBLESHOOTING – POOR OPERATION.
- If problems are fixed by disconnecting the IAC, carefully check connections, IAC valve terminal resistance, or replace IAC.

3. Connect the sensing coil to the ignition module. Make sure that the lock tab on the connector is fastened.

4. Install the retainer (4).

5. Install the shaft assembly (3) into the housing (8).

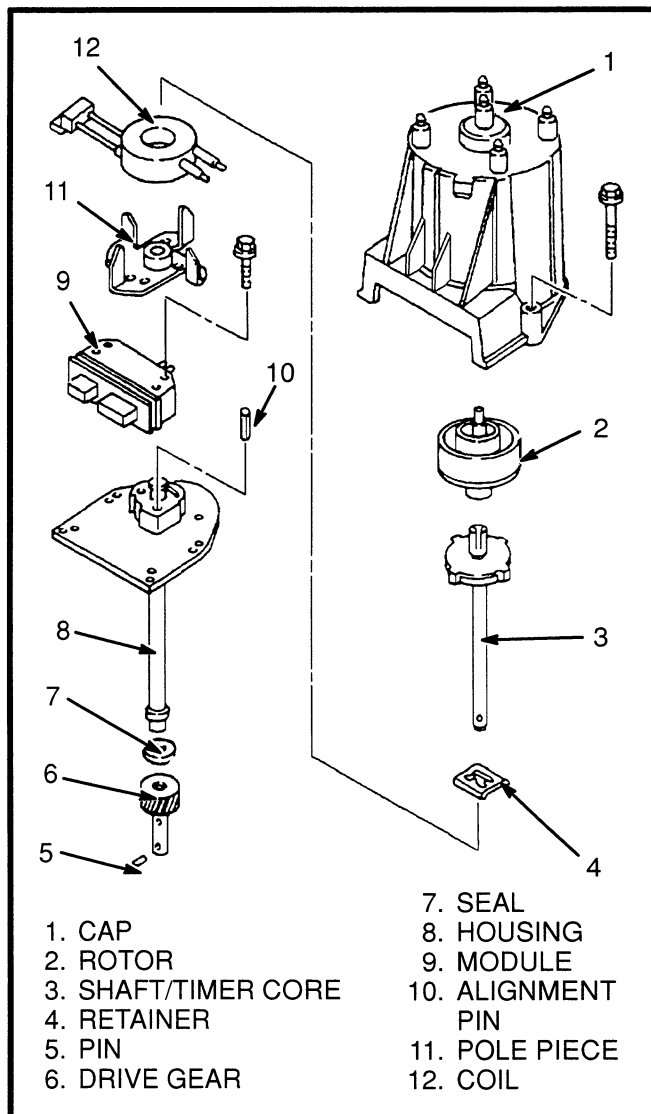

FIGURE 21. DISTRIBUTOR

6. Install the seal (7) on the housing. Install the gear (6) on the end of the shaft.

7. Align the marks on the gear and shaft. Install the roll pin (5). Turn the shaft assembly and make sure the teeth of the timer core on the shaft assembly do not touch the pole piece.

8. Install the rotor (2) on the shaft.

Distributor, Installation

1. Put the rotor and distributor in the same position as it was removed from the engine.

If the engine has been rotated after the distributor was removed, the following procedure must be used before the distributor is installed again:

- Remove the No. 1 spark plug.
- Put a finger over the No. 1 spark plug hole and slowly rotate the engine until pressure is felt on the compression stroke.
- Align the timing mark on the crankshaft pulley to 0° (TDC) on the engine timing indicator.
- Turn the distributor rotor to point between the positions on the distributor cap for No. 1 and No. 4 spark plug leads.
- Install the distributor in the engine. The rotor and shaft will rotate a few degrees when the gear on the distributor shaft engages the drive gear on the engine cam. The timing is correct if the rotor points at the position on the distributor cap for the No. 1 spark plug lead.

2. Install the clamp and bolt. Tighten the bolt with your hand.

3. Install the distributor 4-terminal connector.

4. Install the ignition coil connector.

5. Install the distributor cap and the two capscrews. If the spark plug wires were removed, install them in the correct sequence.

6. Connect the battery negative cable.

7. Start the engine and check the engine timing. See the following paragraphs about "Ignition Timing".

8. Tighten the bolt for the distributor clamp to 43 N.m (25 lb_f ft).

Distributor, Ignition Timing

1. Start and run the engine until it is at the normal operating temperature. Turn the key switch to "OFF".

2. Connect the "SCAN" tool to the DLC connector.

3. Connect a timing light to the No. 1 spark plug wire.

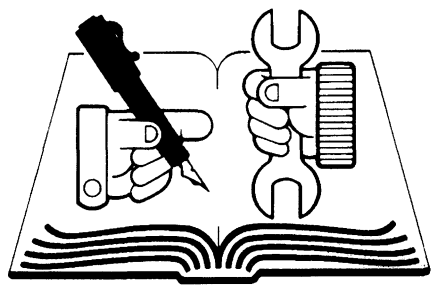

Hyster Easy Language Program

HYSTER TECHNICAL PUBLICATIONS

11. On Type A Delco alternators, do the following checks:

CAUTION

Do not push the screwdriver into the hole for more than 25 mm (1 in.).

- a. If the output shown is not within 10%, put a screwdriver into the hole shown in Figure 11.
- b. Run the engine at 2000 to 2500 rpm. Adjust the carbon pile until the maximum charging rate is reached.
- c. If the output is within 10%, check the field winding. If the field winding is in good condition, replace the voltage regulator.
- d. If the output is not within 10%, check the wires to the brushes, diodes, diode bridge, field winding, and stator.
- e. Remove the screwdriver, ammeter, and variable resistor.

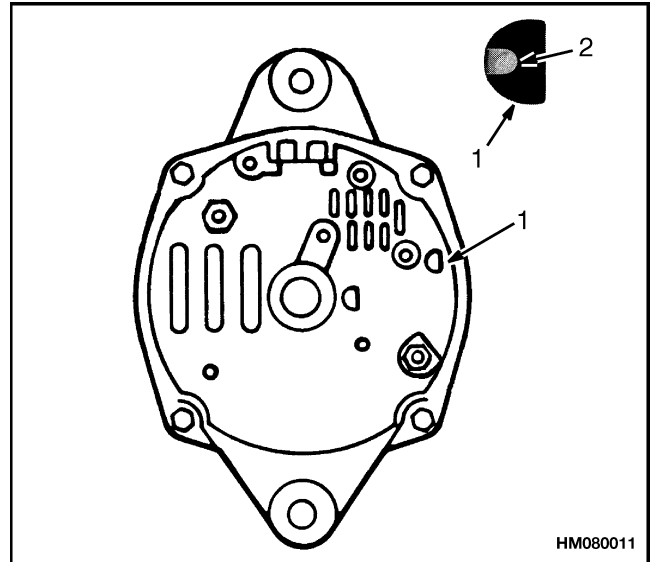

NOTE: DELCO TYPE A SHOWN.

1. HOLE
2. MAKE SURE SCREWDRIVER TOUCHES HOUSING AND METAL TAG.

Figure 11. Electrical Ground on Field Winding

High Output Check (Type A or Type B)

1. Connect a voltmeter from the regulator terminal to the electrical ground. Check the reading on the voltmeter. See Figure 9 or Figure 10.
2. If there are no readings, check for an open circuit between the regulator terminal and the battery.
3. If there is a reading, connect a voltmeter between the BAT terminal and the electrical ground.
4. Increase the engine speed until the maximum voltage reading is reached.
5. If the voltage shown is more than 15.5 volts on a 12-volt system or 31 volts on a 24-volt system, disassemble the alternator and do the remainder of the checks. For alternators with the voltage adjustment, do the following:
 - a. Delco alternator. The voltage setting can be increased or decreased by changing the position of the adjustment plug. See Figure 12. LO is the lowest voltage setting. 2 is medium low and 3 is the medium setting. The voltage setting is highest when HI is aligned with the arrow on the alternator. Do not change the setting when engine is operating. Change the setting as necessary.
 - b. Leece-Neville alternator. Remove the screw in the cover. See Figure 12. Start the engine. Connect a voltmeter across the battery terminals and use a screwdriver to adjust the voltage.

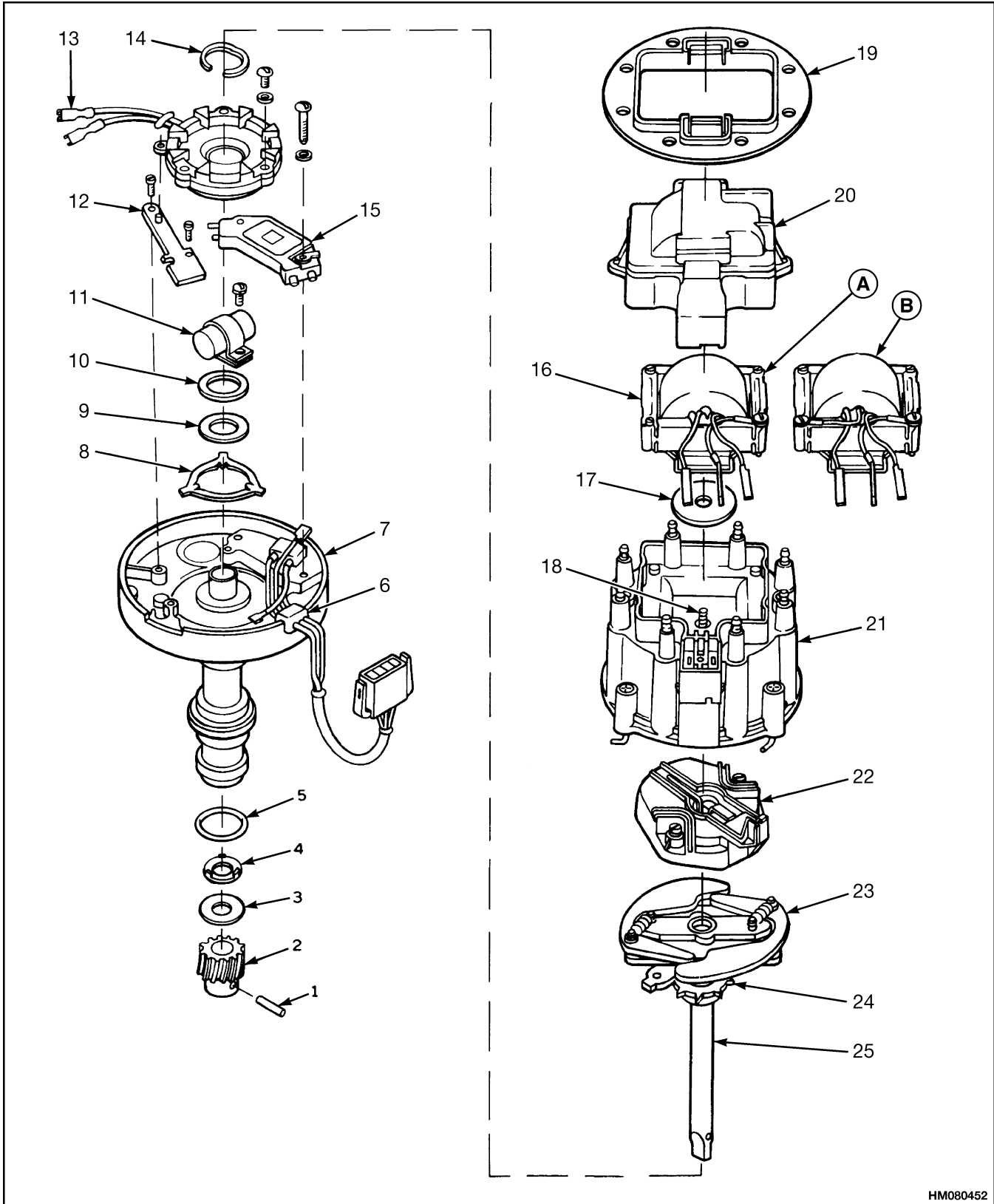

HM080452

Figure 4. GM-V8, Some Models

PROBLEM	POSSIBLE CAUSE	PROCEDURE OR ACTION
Engine does not run correctly.	Ignition timing is not correct.	Perform proper timing procedures. See Ignition Timing Adjustment.
	New spark plugs are needed.	Replace spark plugs. See Spark Plugs Replacement.
	High voltage wires are damaged.	Perform high voltage wire checks. See High Voltage Wires Check.
	Moisture or dirt in the distributor cap.	Clean and dry distributor cap.
	Distributor cap is damaged.	Replace distributor cap.
	Centrifugal mechanism is damaged.	Replace centrifugal mechanism. See Distributor Repair.
	Ignition coil is damaged.	Replace ignition coil. See Ignition Coil Replacement.
	Sensing coil is damaged.	Replace Sensing Coil. See Sensing Coil Replacement.
	The electronic module is damaged.	Replace electronic module. See Electronic Module Replacement.

- Remove the rocker assembly from the cylinder head. See Figure 8.

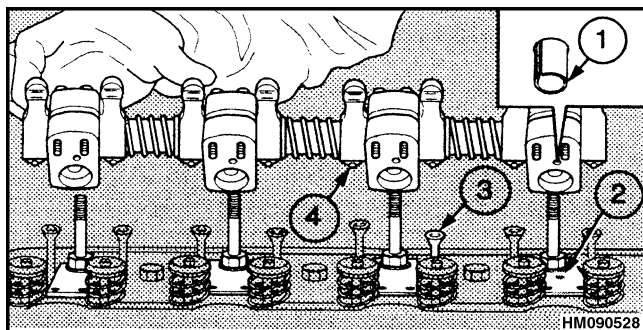

- | | |
|------------------|---------------------|
| 1. ALIGNMENT PIN | 4. ADJUSTMENT SCREW |
| 2. OIL HOLE | |
| 3. PUSH ROD | |

Figure 8. Rocker Assembly

NOTE: A special steel pin is installed in the lower part of the front rocker bracket. See Figure 8. The function of this pin is to make sure this rocker bracket is correctly aligned with the oil hole in the cylinder head. This oil passage is for the oil to lubricate the rocker assembly. Make sure the oil holes are clean.

Disassemble

- Remove the end clips from both ends of the rocker shaft. See Figure 9.

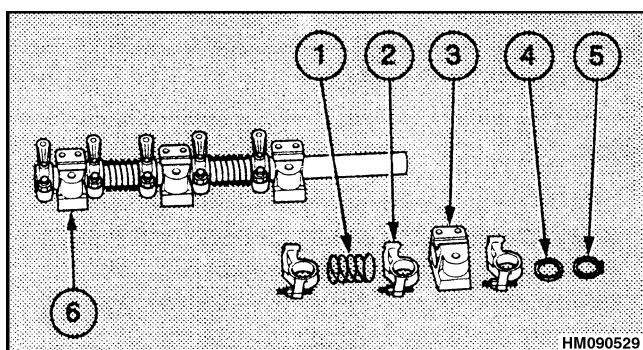

- | | |
|-------------------|------------|
| 1. SPRINGS | 4. SPACER |
| 2. ROCKER LEVER | 5. CLIP |
| 3. ROCKER BRACKET | 6. BRACKET |

Figure 9. Rocker Assembly Components

- Remove the spacer, rocker levers, rocker brackets, and springs.

Assemble

- Clean and inspect the components for wear and damage. Check the clearance between the rocker levers and the rocker shaft. If the clearance is greater than 0.124 mm (0.0049 in.), replace the worn parts.
- Assemble the parts of the rocker assembly as shown in Figure 9.

Install

- Install the rocker assembly on the cylinder head as shown in Figure 8.
- Make sure the stud and plate assembly for the valve cover are installed on the correct rocker brackets. See Figure 7. Make sure the push rods fit into the sockets in the tappets and the rocker levers.
- Install the four nuts and eight capscrews. Tighten the capscrews and nuts only with your fingers. Make sure the parts are correctly fitted together.
- Tighten the nuts evenly to 22 N•m (196 lbf in).
- Tighten the capscrews evenly to 9 N•m (80 lbf in).
- Adjust the valve clearances. See Valve Cover, Install.

Valve Clearance, Adjust

- Check the valve clearance with a spacer gauge between the top of the valve stem and the rocker lever as shown in Figure 10. The engine must be cold. The correct valve clearance for all valves is 0.35 mm (0.014 in.).

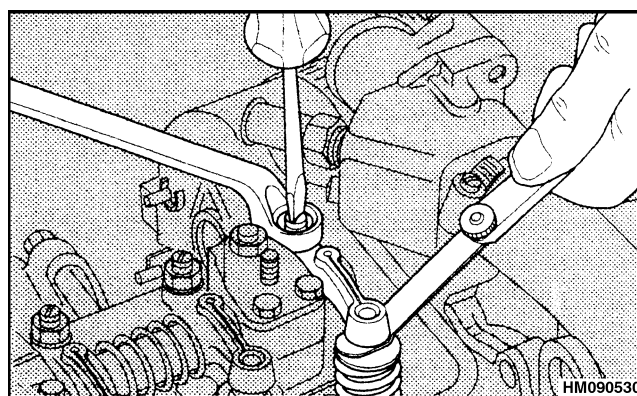
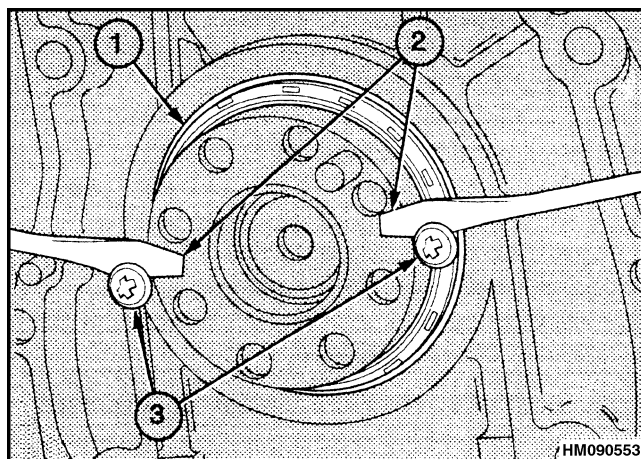

Figure 10. Valve Adjustment

CAUTION

When installing the screw into the oil seal face, make sure the oil seal recess and the front of the crankshaft are not damaged.

4. Install two small self-tapping screws with washers into the face of the oil seal approximately 180 degrees apart.
5. Use suitable levers under the installed screws to pry the oil seal from the housing. See Figure 41.



- | | |
|-------------|------------------------|
| 1. OIL SEAL | 3. SELF-TAPPING SCREWS |
| 2. LEVERS | |

Figure 41. Oil Seal Removal

Install

1. Check that the oil seal area, the outer circumference of the crankshaft flange, and the crankshaft pulley are not worn or damaged.

NOTE: If the oil seal has worn a groove into the pulley surface, a wear sleeve can be installed over the pulley. This only applies to certain model pulleys. See Wear Sleeve, Install.

2. Lubricate the oil seal with engine oil.
3. Use the oil seal replacement tool to carefully press the oil seal into the housing until it protrudes 1.5 mm (0.06 in.) above the rear face of the cylinder block. See Figure 42.

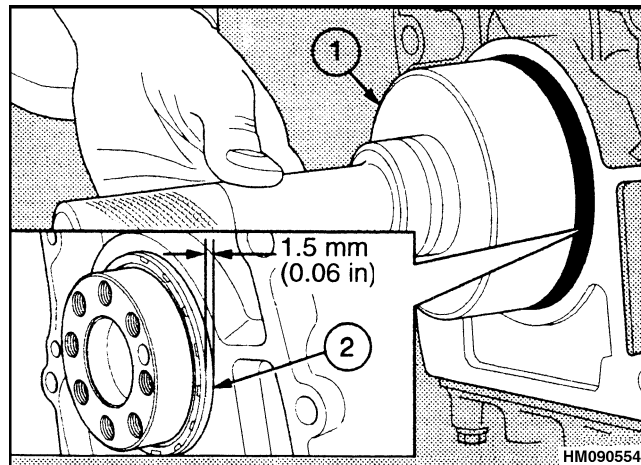

1. OIL SEAL REPLACEMENT TOOL
2. PROTRUSION ABOVE CYLINDER HEAD

Figure 42. Oil Seal Installation

4. Remove all excess oil from the seal and crankshaft face.

Wear Sleeve, Install

NOTE: If the oil seal has caused a groove to be cut into the surface of the pulley, a wear sleeve can be installed on certain types of pulleys. A wear sleeve can only be installed on pulleys of the type shown in Figure 43. All other damaged pulleys must be replaced.

1. With the pulley removed, carefully install the wear sleeve over the pulley. See Figure 44. Install the wear sleeve according to the manufacturer's instructions supplied with the wear sleeve.

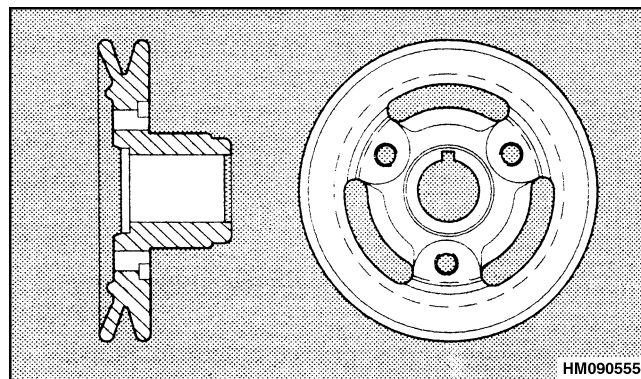

Figure 43. Wear Sleeve-Type Pulley

13. Remove the flywheel and the flywheel housing. See the sections starting with Flywheel.
14. Remove the crankshaft and main bearings. See Crankshaft, Remove.
15. Remove the rear oil seal. See Rear Oil Seal.
16. Inspect the engine block for wear and damage. See Inspect.

Inspect

1. Make sure all of the oil and coolant passages in the engine block are clean.
2. Check the engine block for cracks and damage.

NOTE: The top face of the cylinder block cannot be machined because the pistons will not fit.

3. Check the front bushing for the camshaft for wear. If a new bushing must be installed, use a puller to remove the old bushing. Make sure the oil hole for the new bushing is away from the engine when it is installed. Make sure the oil hole is aligned with the passage in the cylinder block when it is installed. See Figure 75. Use a press to install a new bushing and align it in position in the cylinder block.

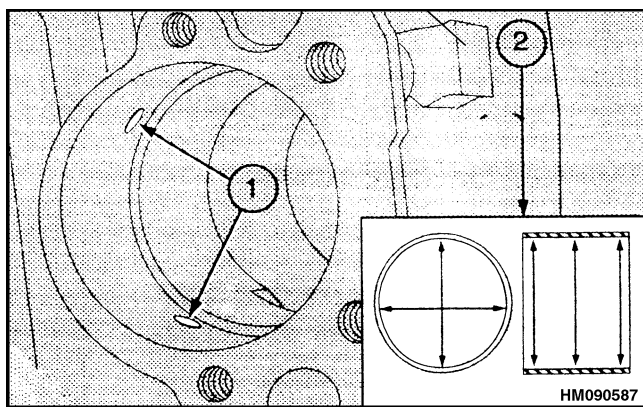

1. OIL HOLES IN BUSHING
2. MEASUREMENT POINTS OF BUSHING

Figure 75. Engine Block Bushing Installation

4. After the bushing is installed, check the bushing diameter in six places as shown in Figure 75.
5. Check the condition of the cylinder bores. See Cylinder Bore, Check.

Cylinder Bore, Check

1. Check the cylinder bores for wear and damage. Check the bores at the top, the center, and the bottom. Check each area in two directions similar to the pattern shown in Figure 75. The wear limit is 0.25 mm (0.010 in.).



CAUTION

If any one cylinder is bored oversize, all cylinders must be bored oversize and new pistons installed. Special training and equipment are often needed to correctly machine the finish on the inner surface of a cylinder bore. To make sure the engine conforms to emissions standards, the bores must be diamond honed, silicon carbide base honed, and carbide plateau honed after the cylinders are bored. Contact a Perkins distributor for additional information.

2. If the bore is worn by more than 0.25 mm (0.010 in.), the bore can be honed 0.5 mm (0.020 in.) oversize.
3. If the cylinder bore has a very smooth finish (glaze), the engine will use oil at a rapid rate even though the cylinder bores are within specifications.

NOTE: If the glaze in a cylinder bore has been removed, the following recommendations are for the next 5 hours of engine operation:

- Do not operate the engine at full load.
- Do not operate the engine at high speed.
- Do not permit the engine to operate at idle speed for long periods.

Assemble

1. Make sure all the parts are clean.
2. Remove the screw plugs from the cylinder block and clean the threads. Apply a sealant to the threads of the plugs and install them in the cylinder block.
3. Install the rear oil seal. See Rear Oil Seal.
4. Install the crankshaft and main bearings. See Crankshaft, Install.
5. Install the flywheel and the flywheel housing. See the sections starting with Flywheel.

- Remove the nut, the spring washer, and the plain washer from the shaft (parts not shown).

NOTE: If the shaft and the spring are not being replaced, do not separate them.

- Remove the lever and spring from the shaft. See Figure 104.

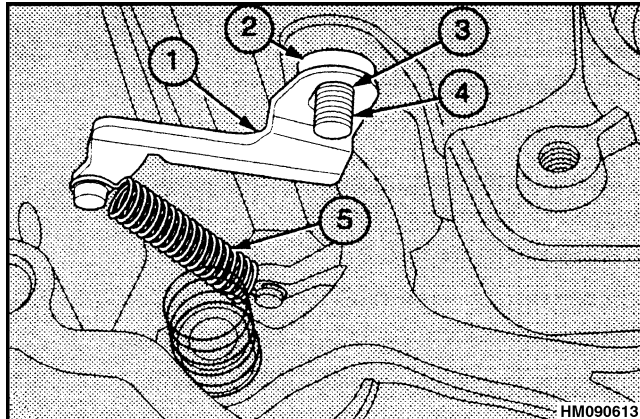

- | | |
|--------------|-----------|
| 1. LEVER | 4. SHAFT |
| 2. BUSHING | 5. SPRING |
| 3. FLAT FACE | |

Figure 104. Engine Speed Control Disassembly



CAUTION

The bushing is permanently installed in the timing case. Do not try to remove it, or the timing case will be damaged.

- From the opposite side of the timing case, remove the lever from the bushing. See Figure 105.
- Inspect the components for wear or damage.

Replace

- Remove the nut from the lever.
- Remove the lever and the O-rings from the shaft. Discard the O-rings.
- Inspect the components and replace as necessary.
- Install new O-rings and put the lever on the shaft. Make sure the lever is lined up with the Woodruff key.

- Put the nut on the lever and tighten to 45 N•m (33 lbf ft). Make sure the slot on the lever is clean.

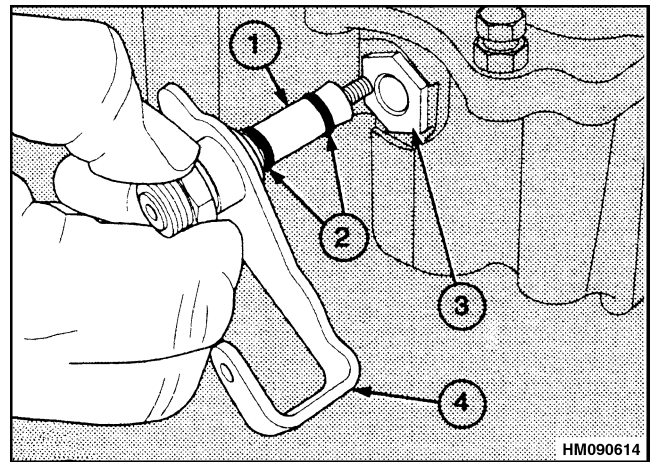

- | | |
|------------|------------|
| 1. SHAFT | 3. BUSHING |
| 2. O-RINGS | 4. LEVER |

Figure 105. Engine Speed Control Assembly

Install

- Clean and lubricate the shaft and the O-rings with a small amount of grease.
- Insert the lever assembly through the bushing in the timing case. See Figure 105.
- Make sure both ends of the spring are attached to the levers. See Figure 104.
- Install the lever, with the spring, onto the flat face of the shaft.



CAUTION

Make sure the Loctite™ does not get into the bushing in the timing case.

- Put a small amount of Loctite™ 243 on the threads of the shaft.
- Install the plain washer, the spring washer, and the nut on the shaft.
- Tighten the nut to 10.5 N•m (93 lbf in).

Table 17. Crankshaft Overhaul Specifications (Continued)

When the crankshaft is on mounts at the front and rear main journals, the maximum variation (run-out) (total indicator reading) at the other main journals cannot be greater than the following. The "run-out" must not be opposite. The difference in run-out between one journal and the next one must not be more than 0.10 mm (0.004 in.).	
Journal	4-Cylinder Crankshafts
1	Mount
2	0.08 mm (0.003 in.)
3	0.15 mm (0.006 in.)
4	0.08 mm (0.003 in.)
5	Mount

Table 18. Main Bearings

Type	Steel back, 20% tin to aluminum bearing material
Bearing width	25.70 to 26.00 mm (1.01 to 1.02 in.)
Bearing thickness	1.993 to 1.999 mm (0.0785 to 0.0787 in.)
Bearing clearance	0.032 to 0.092 mm (0.0013 to 0.0036 in.)
Available undersize bearings	-0.25 mm (-0.010 in.)
	-0.50 mm (-0.020 in.)
	-0.75 mm (-0.030 in.)

Table 19. Crankshaft Thrust Washers

Type	Steel back, lead bronze bearing material
Position	Each side of the number four main bearing
Thickness:	
- Standard	2.38 to 2.44 mm (0.0937 to 0.0961 in.)
- Oversize	2.58 to 2.64 mm (0.102 to 0.104 in.)

TIMING CASE AND GEAR ASSEMBLY

Refer to the following tables for specifications of the timing case and gear assembly.

Table 20. Camshaft

Diameter, journals	47.945 to 47.975 mm (1.8876 to 1.8888 in.)
Clearances:	
Journal number one	0.025 to 0.155 mm (0.0010 to 0.0060 in.)
Journals two to five	0.050 to 0.115 mm (0.0020 to 0.0050 in.)
Cam lift:	
- Inlet	7.06 to 7.16 mm (0.278 to 0.282 in.)
- Exhaust	7.35 to 7.45 mm (0.289 to 0.293 in.)
Maximum out of round and wear on journals	0.05 mm (0.002 in.)
Axial movement	
- Production limit	0.10 to 0.25 mm (0.004 to 0.010 in.)
- Service limit	0.35 mm (0.014 in.)

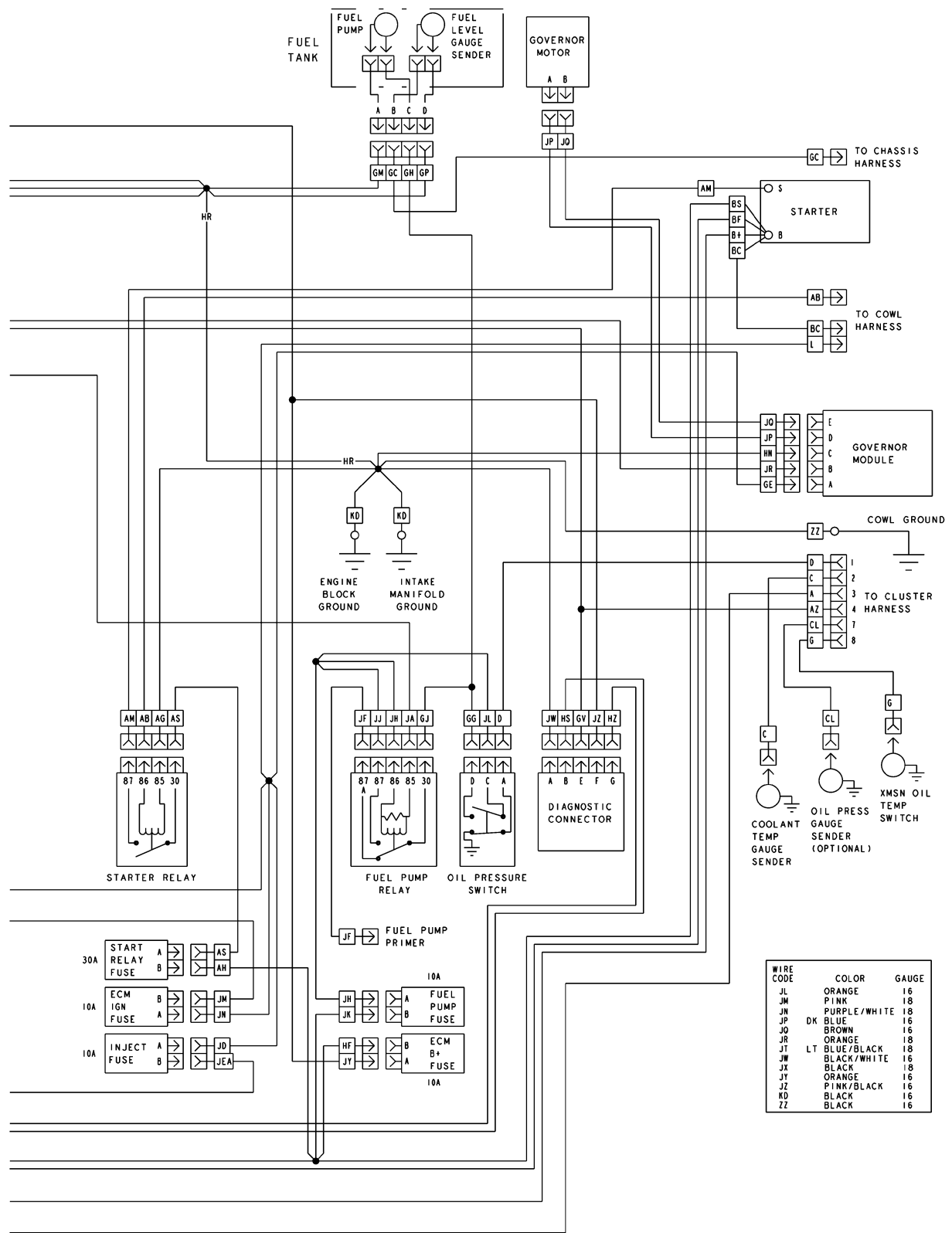

HS210001

Figure 2. GM 3.0L Gasoline Engine Wiring Schematic (Late Models)

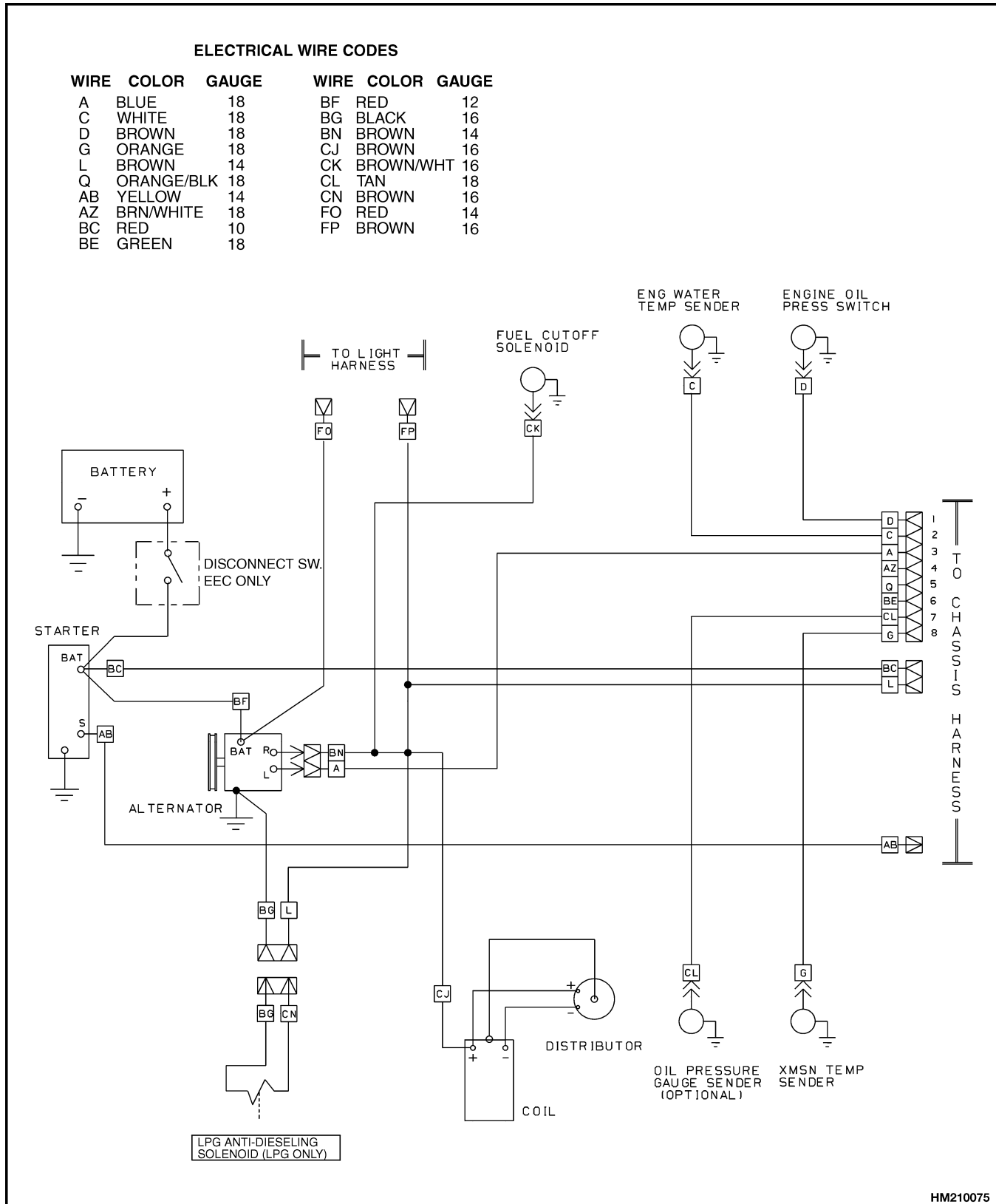
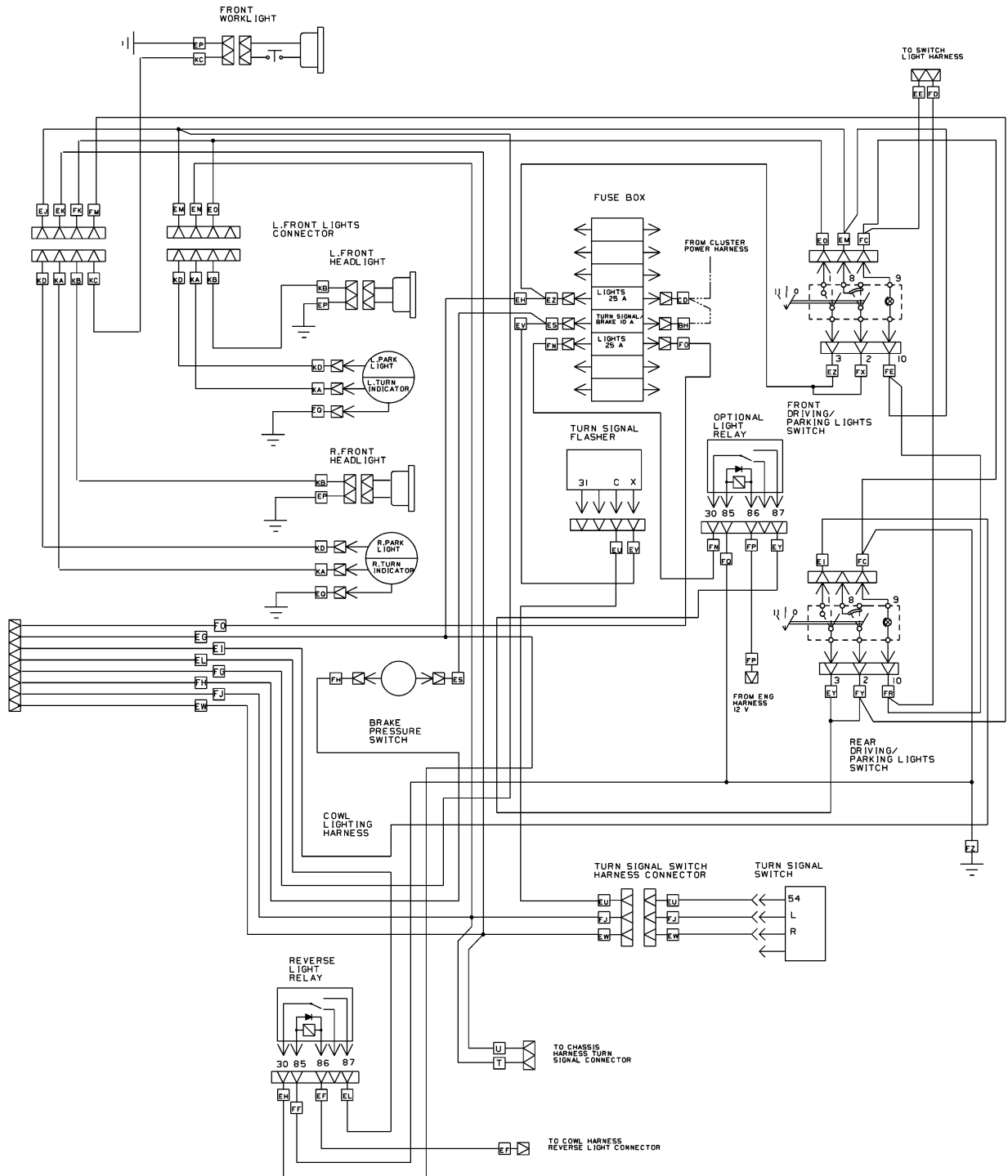

Figure 9. Mazda Gasoline or LPG Engine Wiring Schematic (Early Models)



HM210090

Figure 22. Lights Wiring Schematic (Late Models)

SAFETY PRECAUTIONS

MAINTENANCE AND REPAIR

- When lifting parts or assemblies, make sure that all slings, chains or cables are correctly fastened and that the load being lifted is balanced. Make sure that the crane, cables and chains have the capacity to support the weight of the load.
- Do not lift heavy parts by hand. Use a lifting mechanism.
- Wear safety glasses.
- **DISCONNECT THE BATTERY CONNECTOR** before doing any maintenance or repair on electric lift trucks. Disconnect the battery ground cable on internal combustion lift trucks.
- Always use correct blocks to prevent the unit from rolling or falling. See “How To Put The Lift Truck On Blocks” in the **OPERATING MANUAL** or the **PERIODIC MAINTENANCE** section.
- Keep the unit and working area clean and in order.
- Use the correct tools for the job.
- Keep the tools clean and in good condition.
- Always use **HYSTER APPROVED** parts when making repairs. Replacement parts must meet or exceed the specifications of the original equipment manufacturer.
- Make sure that all nuts, bolts, snap rings and other fastening devices are removed before using force to remove parts.
- Always fasten a **DO NOT OPERATE** sign to the controls of the unit when making repairs or if the unit needs repairs.
- Make sure you follow the **WARNING** and **CAUTION** notes in the instructions.
- Gasoline, Liquid Petroleum Gas (LPG), and Diesel are flammable fuels. Make sure that you follow the necessary safety precautions when handling these fuels and when working on these fuel systems.
- Batteries generate flammable gas when they are being charged. Keep fire and sparks away from the area. Make sure the area has ventilation.

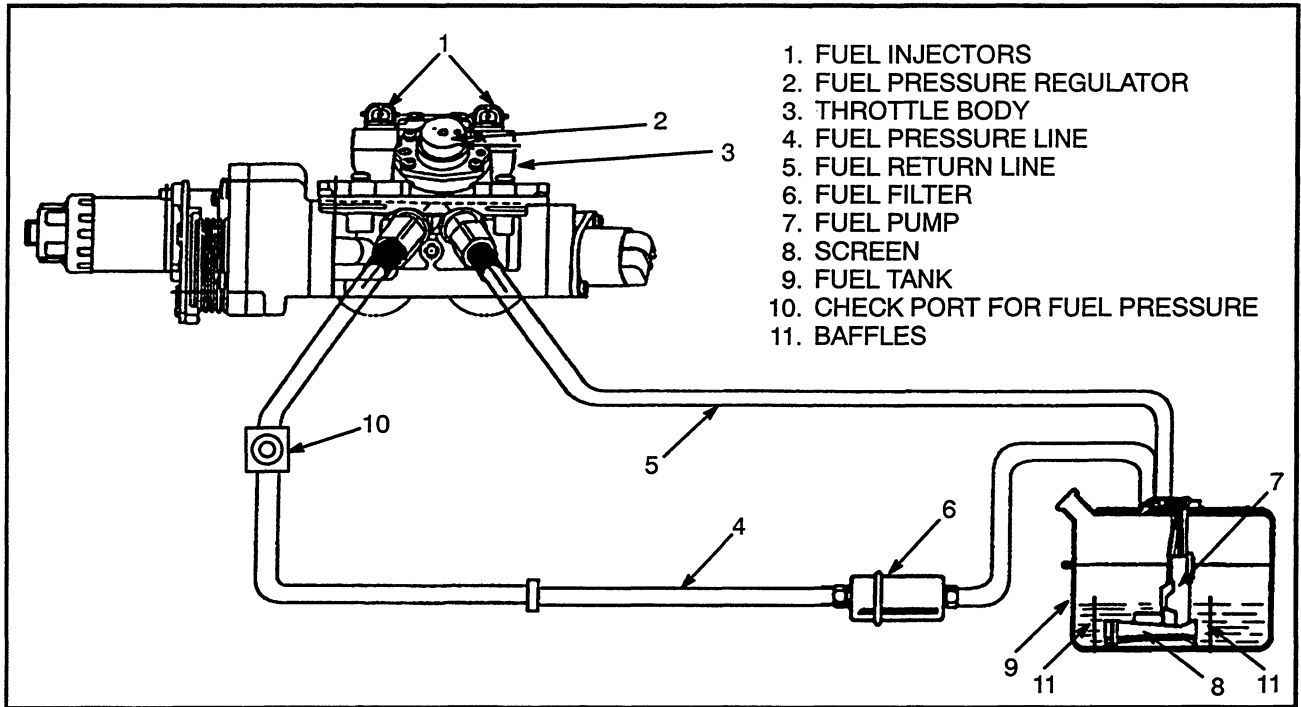

FIGURE 18. TYPICAL FUEL SUPPLY SYSTEM

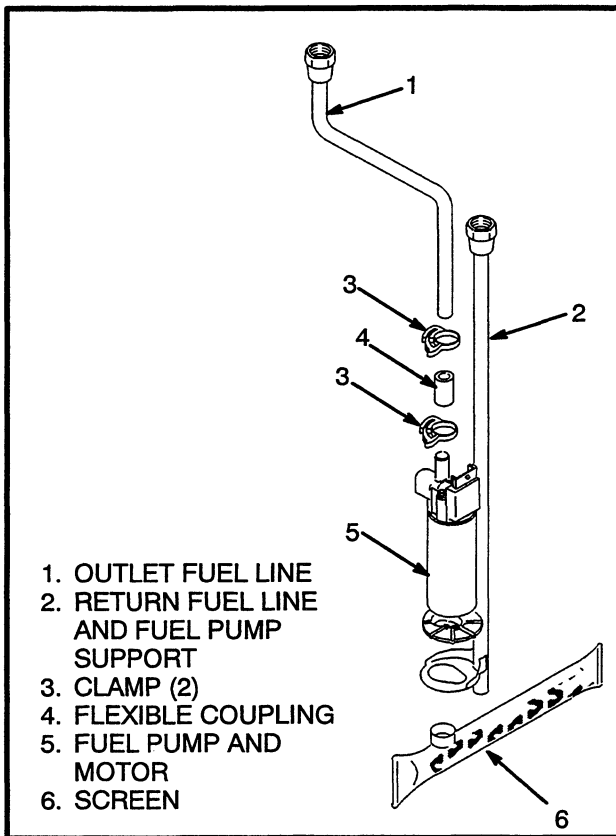

FIGURE 19. FUEL PUMP

This ECM control also prevents the fuel pump from operating if the ignition switch is turned to ON and the engine is not running. This control prevents emptying the fuel tank through an open fuel line if the engine is not running and the ignition switch stays ON.

When the engine is running or being cranked by the starter, the ECM receives reference pulses from the EST distributor or the DIS module. The ECM then energizes the fuel injectors.

The fuel pump can also be energized by the oil pressure sensor. When the engine is being cranked by the starter and engine oil pressure is approximately 28 kPa (4 psi), the oil pressure switch closes a circuit to operate the fuel pump. If the fuel pump relay is not operating correctly, a long cranking time for a cold engine will be the result. The oil pressure switch will energize the fuel pump when the engine oil pressure increases to approximately 28 kPa (4 psi).

ECM SENSORS AND CONTROLLERS

Manifold Absolute Pressure (MAP)

The Manifold Absolute Pressure (MAP) sensor is a pressure transducer that measures changes in the pressure in the intake manifold. See FIGURE 20. The pressure changes are a result of engine load and speed

TABLE 1. ECM DIAGNOSTIC CODES AVAILABLE

CODE	DESCRIPTION	TURN ON MALFUNCTION INDICATOR LAMP
14	Engine Coolant Temperature Sensor Circuit - High Volts	Yes
15	Engine Coolant Temperature Sensor Circuit - Low Volts	Yes
21	Throttle Position Sensor - High Volts	Yes
22	Throttle Position Sensor - Low Volts	Yes
31	Governor Circuit Malfunction	Yes
33	MAP Sensor Circuit - High Volts	Yes
34	MAP Sensor Circuit - Low Volts	Yes
41	Ignition Control (IC) System. Open EST Circuit	Yes
42	Ignition Control (IC) System - Grounded EST Circuit or Open or Grounded Bypass Circuit.	Yes
51	ECM Internal Problem	Yes

⚠ CAUTION

To prevent ECM damage, the key must be OFF when disconnecting or reconnecting ECM power.

Diagnostic Mode

When the SCAN tool is connected to the Diagnostic Connector with the key switch ON and the engine OFF, the system will enter the Diagnostic Mode.

1. Display a DTC 12 by flashing the Malfunction Indicator lamp (indicating the system is operating correctly).
2. Display any additional stored DTC's by flashing the Malfunction Indicator lamp. Each DTC will flash three times, then DTC 12 will flash again.
3. The IAC valve moves to its fully extended position, blocking the idle air passage.

Field Service Mode

If the SCAN tool is connected to the Diagnostic Connector and turned ON with the engine running, the system will enter the Field Service mode. For the GM 3.0L engine, this will cause the engine to run at approximately 1500 rpm and 8° before top dead center spark advance. For the GM 4.3L engine, the numbers are approximately 1000 rpm and 0° before top dead center spark advance. While the system is in Field Service Mode, new trouble codes can be kept in the ECM.

NOTE: The ignition timing can be set with a timing light.

ECM Learning Ability

The ECM has a learning ability that lets it make corrections for variations in the idle system to improve idle performance. If the battery is disconnected for any reason, the learning process resets and begins again. To teach the vehicle, make sure that the engine is at operating temperature. Drive the lift truck at part throttle, with moderate acceleration, and idle until normal performance returns.

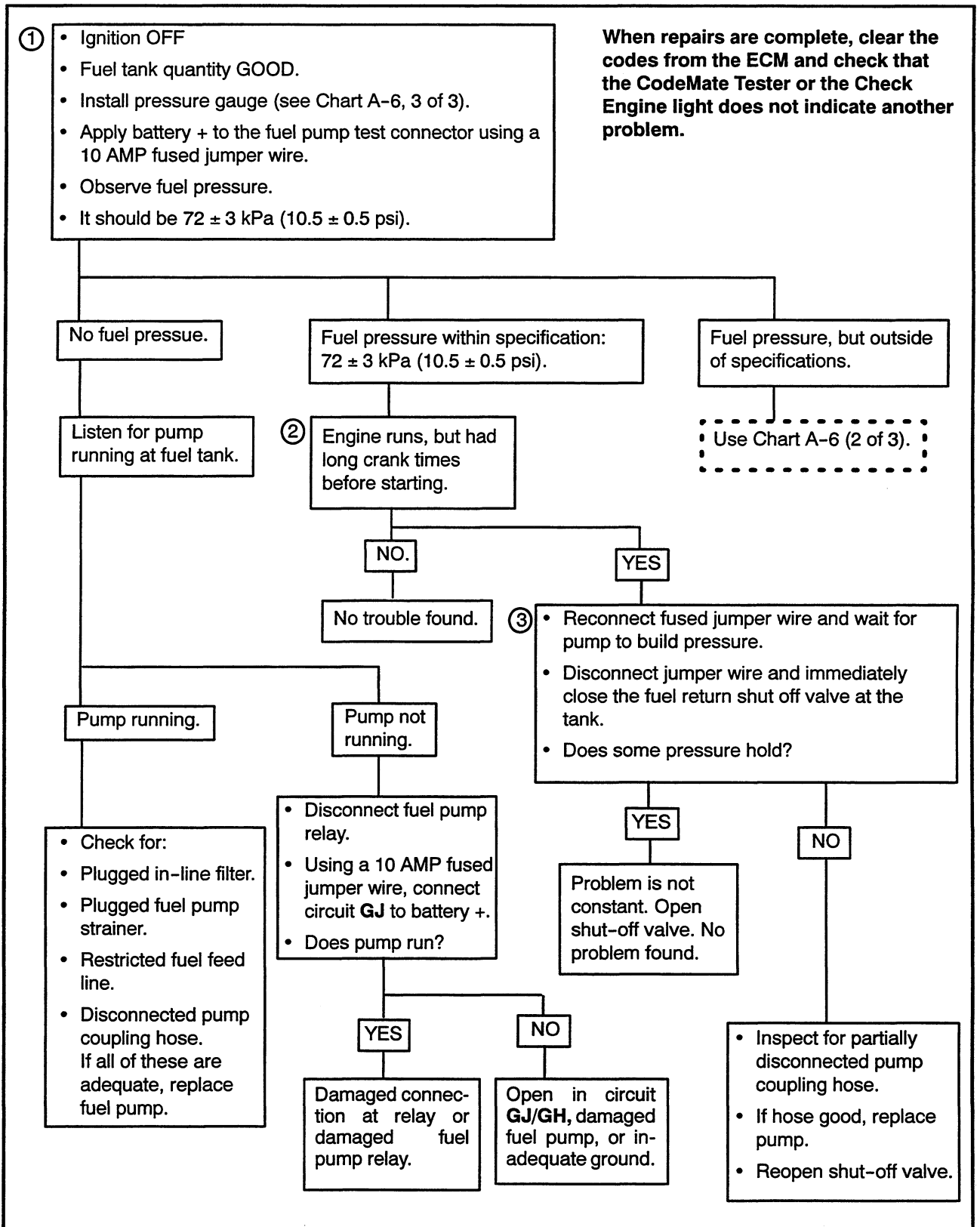
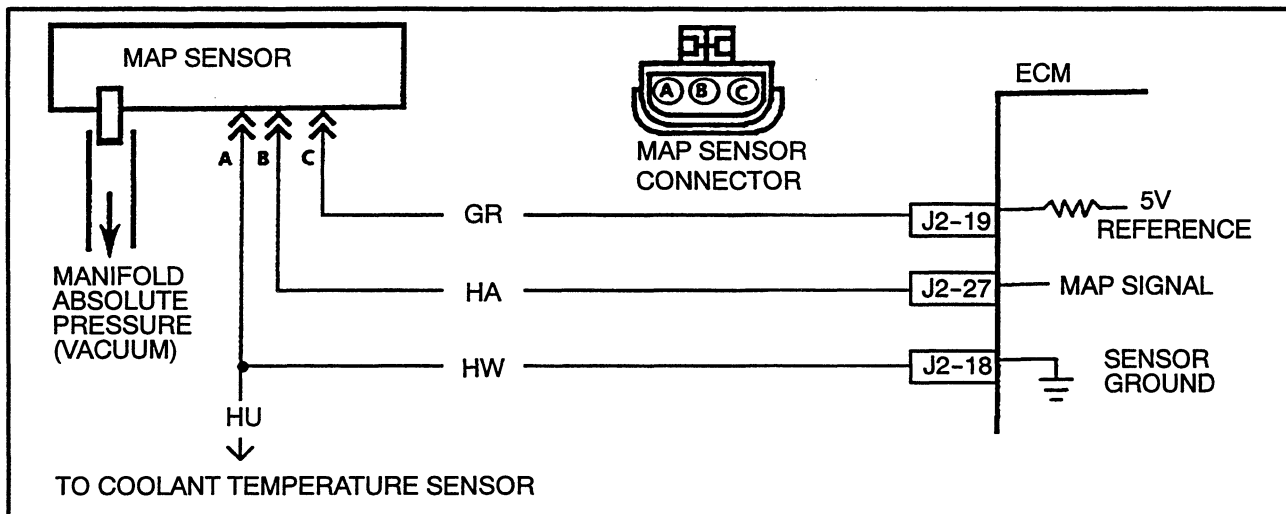

CHART A-6 — Fuel System Troubleshooting



DTC 33 MANIFOLD ABSOLUTE PRESSURE (MAP) SENSOR CIRCUIT (SIGNAL VOLTAGE HIGH - LOW VACUUM)

CIRCUIT DESCRIPTION

The Manifold Absolute Pressure (MAP) sensor responds to changes in manifold pressure (vacuum). The ECM receives this information as a signal voltage that will vary from about 1 to 1.5 volts at closed throttle idle, to 4 to 4.5 volts at wide open throttle (low vacuum). If the MAP sensor fails, the ECM will use a fixed MAP value and use the Throttle Position (TP) Sensor to control fuel delivery.

Test Description: The number(s) below are a reference to number(s) in circles in the troubleshooting chart on the next page.

1. This step will determine if DTC 33 is caused by a current failure or a condition that is not constant.

- A DTC 33 will set if:

MAP signal is more than 90 kPa (low manifold vacuum),

TP Sensor less than 5%,

These conditions for a time longer than 10 seconds.

2. This step causes the conditions for a DTC 34. If the ECM sees the change, the ECM and circuits HA and HW are good.

3. See SYSTEM TEST CHARTS for complete test of MAP sensor.

Other Troubleshooting Checks:

- With the ignition ON and the engine stopped, the manifold pressure is equal to atmospheric pressure and the signal voltage will be high. This information is used by the ECM as an indication of vehicle altitude and is referred to as BARO. Comparison of this BARO reading with a known good vehicle with the same type sensor is a good way to check accuracy of a sensor. Correct readings will be within 0.4 volt of each other.
- A DTC 33 occurs if either circuit HW is open, or if circuit GR has a short to voltage or to circuit HA.
- If HW is open, DTC 33 and DTC 14 will set.
- If DTC 33 is not constant, see TROUBLESHOOTING - POOR OPERATION.

12. Reset IAC valve pintle position:

- a. Start and run engine over 2000 rpm.
- b. Select Field Service Mode.
- c. Run engine at 2000 rpm for approximately 10 seconds.
- d. Exit Field Service Mode.
- e. Allow engine to return to idle.
- f. Turn ignition switch OFF.
- g. Wait 10 seconds, start engine, let idle.
- h. Check for correct idle. (IAC at 5-40 Counts.)
- i. Disconnect SCAN tool.
- j. Remove blocks from drive tires

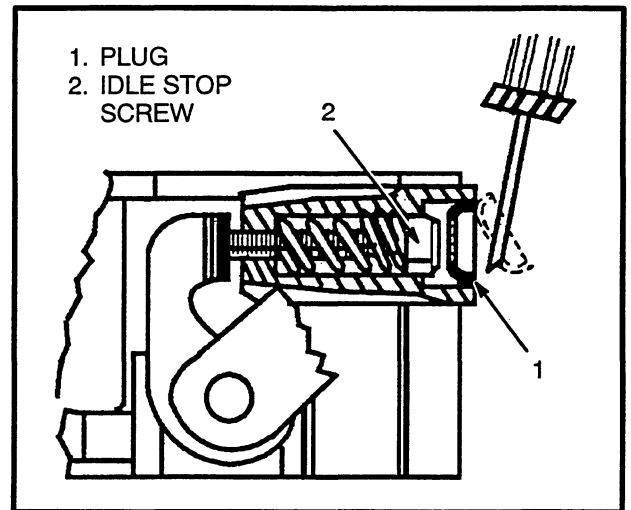

FIGURE 10. IDLE SPEED ADJUSTMENT

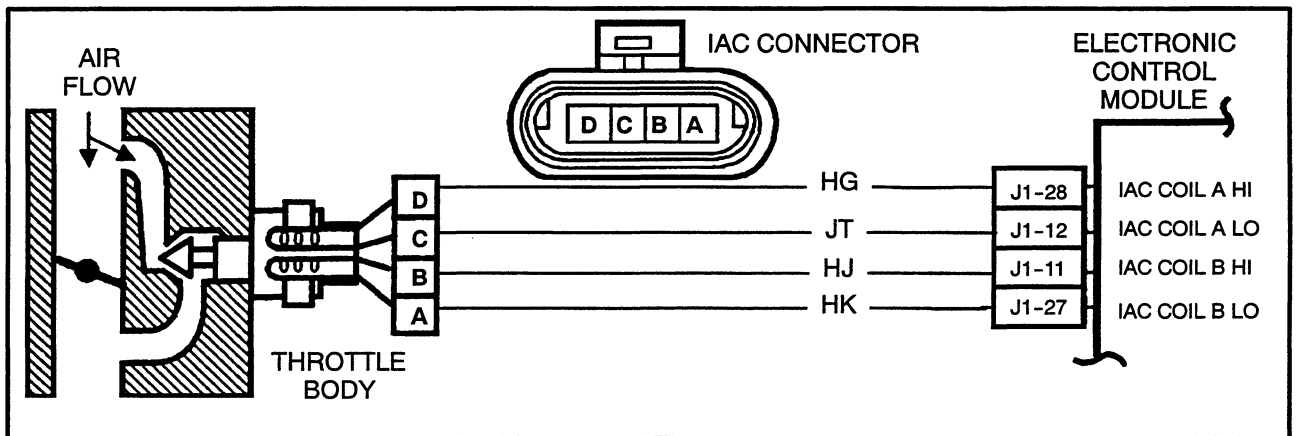

CHART B-1

IDLE AIR CONTROL (IAC) SYSTEM CHECK

CIRCUIT DESCRIPTION

The ECM controls engine idle speed with the IAC valve. To increase idle speed, the ECM retracts the IAC valve pintle away from its seat, allowing more air to bypass the throttle bore. To decrease idle speed, the IAC valve pintle extends towards its seat, reducing by-pass air flow. A SCAN tool will read the ECM commands to the IAC valve in counts. The higher the counts indicate more air bypass (higher idle). The lower the counts indicate less air is allowed to bypass (lower idle).

Other Troubleshooting Checks:

- A slow, unstable, or fast idle speed can be caused by a problem other than the IAC system. Out of control range IAC SCAN tool

counts will be above 50 if idle is too low, and zero counts if idle is too high. Make the following checks to repair a problem that is not in the IAC system:

- Vacuum Leak (High Idle) - If idle is too high, stop the engine. Fully extend (low) IAC with tester. Start engine. If idle speed is above 800 RPM, fix vacuum leak including PCV system. Also check for smooth movement of the throttle plate or linkage.
- PCV Valve - If a high idle condition exists (800 to 1000 RPM), check for vacuum leaks and correct PCV valve operation. All throttle bodies are preset at the factory and do not need

4. Use a new gasket and connect the air filter to the TBI.

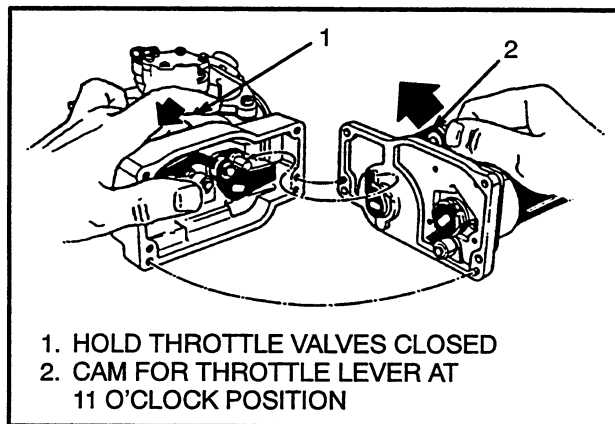

1. HOLD THROTTLE VALVES CLOSED
2. CAM FOR THROTTLE LEVER AT 11 O'CLOCK POSITION

FIGURE 26. ALIGN THE GOVERNOR THROTTLE DRIVE

Governor Drive Motor, Removal

1. Remove the governor motor and throttle drive assembly (see FIGURE 27.).

CAUTION

The spring for the throttle lever has tension. Hold the throttle valves closed, then rotate the cam for the throttle lever clockwise. Rotate the cam until the ball joint for the throttle cable is in the 11 o'clock position. See FIGURE 26. This procedure will prevent damage to the throttle drive assembly.

2. Disconnect the spring from the motor lever so that the motor lever will be free when the drive motor is removed. See FIGURE 27.

3. Remove the four screws that hold the drive motor to the cover plate. Remove the screw under the

throttle lever cam last. Move the throttle lever cam clockwise from the drive motor to prevent the release of spring tension. See FIGURE 30.

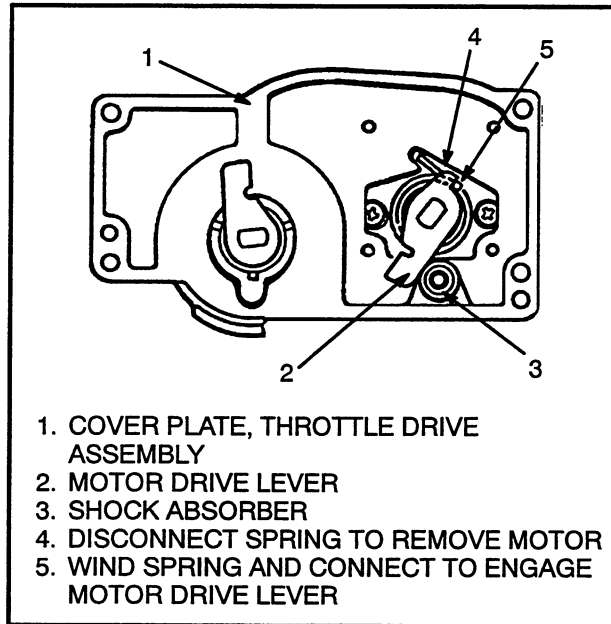

1. COVER PLATE, THROTTLE DRIVE ASSEMBLY
2. MOTOR DRIVE LEVER
3. SHOCK ABSORBER
4. DISCONNECT SPRING TO REMOVE MOTOR
5. WIND SPRING AND CONNECT TO ENGAGE MOTOR DRIVE LEVER

FIGURE 27. GOVERNOR DRIVE MOTOR ARRANGEMENT

4. Remove the drive motor.

5. Remove the shock absorber(s) only if it is damaged. See FIGURE 29.

Governor Drive Motor, Cleaning and Lubrication (See FIGURE 28.)

Some parts of the governor throttle drive need to be lubricated with a special grease (Mobil No. 28 or equivalent). Clean and lubricate these parts only if new parts are used or there is no grease on the parts. Lubricate the parts as shown in FIGURE 28.

ECM CONNECTOR J2 IDENTIFICATION

PIN NO.	CKT NO.	FUNCTION	To PIN	PIN NO.	CKT NO.	FUNCTION	To PIN
1	HD	Diagnostic Connector ECM B+ Fuse	F A	17		Not Used	
2		Not Used		18	HW HU	Coolant Temperature Sensor MAP Sensor	A A
3	HV	Throttle Position Sensor	B	19	GR	MAP Sensor	C
4	GT	Throttle Positon Sensor	A	20	JX	Not Used	
5		Not Used		21		Not Used	
6		Not Used		22	HS	Diagnostic Connector	B
7		Not Used		23		Not Used	
8		Not Used		24		Not Used	
9		Not Used		25		Not Used	
10	GY	Distributor, Reference	D	26	GU	Throttle Positon Sensor	C
11	GQ	Coolant Temperature Sensor	B	27	HA	MAP Sensor	B
12		Not Used	C	28		Not Used	
13		Not Used		29		Not Used	
14		Not Used		30		Not Used	
15		Not Used		31		Not Used	
16		Not Used		32	JM GE BCC	ECM Fuse Governor Controller (GM 3.0L) Ignition Coil	B A B

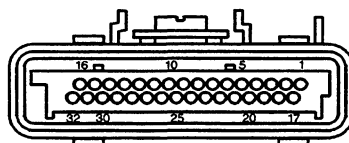

CONNECTOR J2

LPG Tank Repair

REMOVE

WARNING

Before disconnecting any part of the LPG fuel system, close shutoff valve on fuel tank. Run engine until fuel lines are empty and engine stops. If engine will not run, close shutoff valve on fuel tank and release fuel slowly in a non-hazardous area.

LPG can cause an explosion even when tanks are empty. When replacing tanks, do not weld, cause sparks, or permit flammable material on or near tanks. Do not change tanks when engine is running. Tanks must be filled by authorized personnel. Follow all safety rules. Do not remove any parts from tank.

Frost on surface of tank, valves, or fittings and the odor of LPG fuel indicates a leak. Inspect LPG system and repair a leak immediately. An LPG fuel leak creates an explosion hazard and a fire hazard. Do not attempt to start engine if there is a leak in LPG fuel system.

Do not use any LPG tank that is damaged. Damaged tanks must be removed from service.

Do not store LPG tanks near heat or an open flame. For complete instructions on the storage of LPG fuels, refer to ANSI/NFPA 58 & 505.

WARNING

LPG is very cold. Always wear gloves to protect your hands from LPG and the cold metal of the tank. Do not permit LPG to contact skin.

WARNING

LPG tanks are heavy. The weight of an LPG tank can exceed the maximum recommended weight for safe lifting by an individual. Get assistance when lifting or lowering an LPG tank. Use correct lifting procedures.

1. Move lift truck to area where tanks are changed.
2. Turn shutoff valve clockwise until valve is completely closed. See Figure 10.
3. Run engine until it stops. Then turn key to **OFF** position.

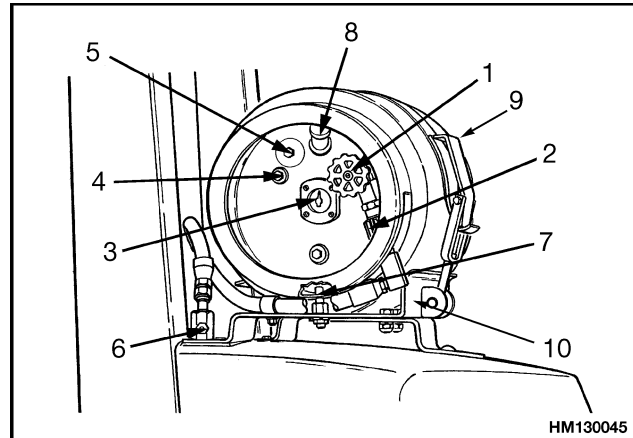

NOTE: SOME LPG TANKS HAVE AN AUXILIARY FILL FITTING INSTEAD OF A PLUG FOR ITEM 4.

- | | |
|-----------------------------|----------------------|
| 1. SHUTOFF VALVE | 6. RELIEF VALVE |
| 2. QUICK-DISCONNECT FITTING | 7. ALIGNMENT PIN |
| 3. FUEL GAUGE | 8. TANK RELIEF VALVE |
| 4. PLUG | 9. TANK LATCH |
| 5. LIQUID LEVEL INDICATOR | 10. MOUNTING BRACKET |

Figure 10. LPG Tank

4. Disconnect quick-disconnect fitting.
5. Release tank latch and remove tank from bracket.

INSTALL

1. Before the tank is installed on the lift truck, check operation of fuel gauge. See Figure 10. Look at fuel gauge and move tank. The needle of the gauge must move when the fuel moves. If the needle does not move, a new tank must be installed.

WARNING

Make sure that alignment pin extends through correct hole in rim of LPG tank. The hose or fittings can be damaged if the LPG tank is not installed in the correct position. A damaged hose or fitting can release LPG fuel and cause an explosion hazard and fire hazard.

2. Install LPG tank in its bracket so that alignment pin is in correct hole in bracket. Close latches.
3. Connect quick-disconnect fitting to shutoff valve on tank. Use your hand to tighten fitting.

CLICK HERE TO **DOWNLOAD** THE COMPLETE MANUAL

- Thank you very much for reading the preview of the manual.
- You can download the complete manual from: www.heydownloads.com by clicking the link below



- Please note: If there is no response to CLICKING the link, please download this PDF first and then click on it.

CLICK HERE TO **DOWNLOAD** THE COMPLETE MANUAL