

BATTERY INDICATORS

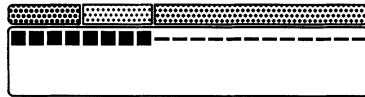
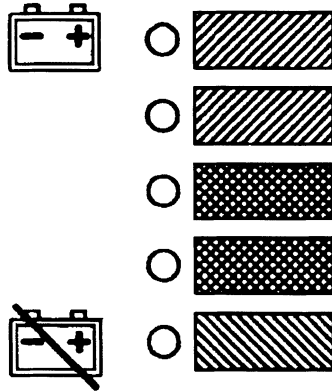

HM010000

HYSTER

CLICK HERE TO **DOWNLOAD** THE COMPLETE MANUAL

- Thank you very much for reading the preview of the manual.
- You can download the complete manual from: www.heydownloads.com by clicking the link below



- Please note: If there is no response to CLICKING the link, please download this PDF first and then click on it.

CLICK HERE TO **DOWNLOAD** THE COMPLETE MANUAL

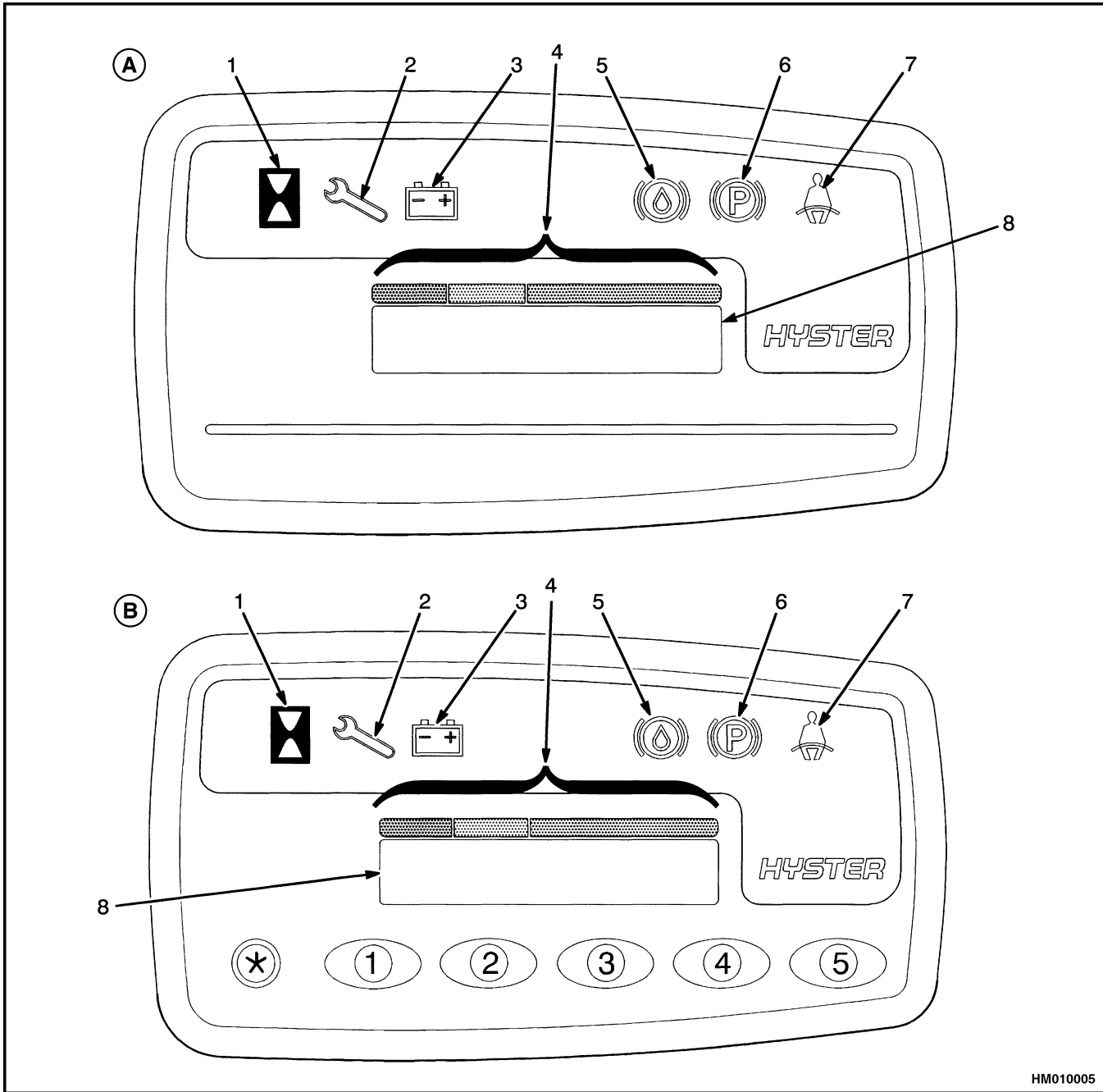

HM010005

A. STANDARD DISPLAY PANEL

- 1. HOURMETER INDICATOR SYMBOL
- 2. SERVICE REMINDER INDICATOR
- 3. LOW BATTERY INDICATOR
- 4. BATTERY DISCHARGE INDICATOR (BDI)

B. PREMIUM DISPLAY PANEL

- 5. BRAKE FLUID TOO LOW SYMBOL
- 6. PARKING BRAKE SYMBOL
- 7. SEAT BELT SYMBOL
- 8. LCD SCREEN

Figure 5. Battery Indicator With SEM Display Panel

TESTING

Inoperative Dash Display Assembly

If the dash display is blank (no display, LEDs etc.), with the key switch **ON** and the main contactor energized, see the section **Electrical System** for your lift truck. Refer to STATUS, WARNING AND FAULT CODES, BLANK DASH DISPLAY for troubleshooting procedures.

Inoperative Drive Mode Selection

Communication from the dash display to the traction motor controller occurs through two wires, DM1 and

DM2. See Figure 11. Wires DM1 and DM2 are located in the X-6 connector of the dash display and in the X-3 connector at the traction motor controller. A digital signal is carried to tell the traction motor controller to operate in one of the three drive modes (Turtle, Mid, or Rabbit modes).

If pressing the mode selection button causes the green LED mode indicators to change, but truck performance appears unchanged, see the next section to check the communication from the dash display to the traction motor controller.

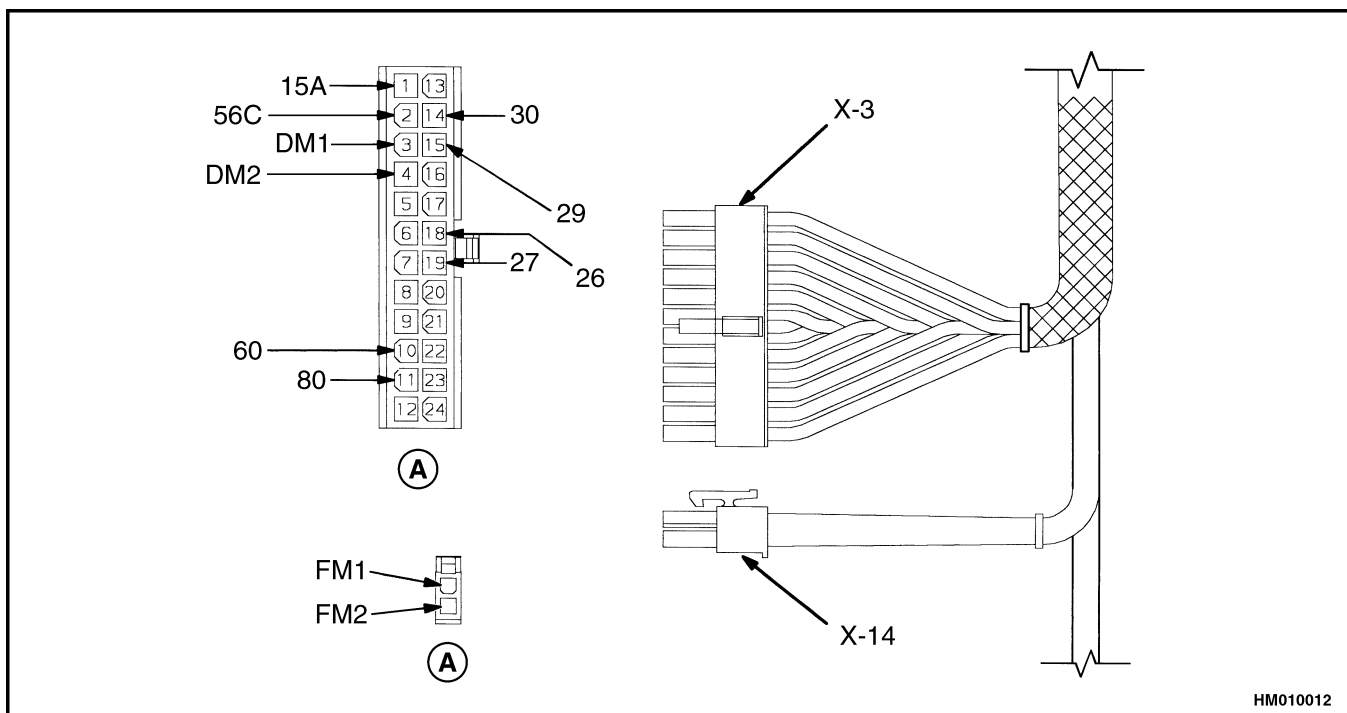

A. FRONT VIEW

Figure 11. Traction Motor Controller Connection Pin-Out

Troubleshooting With a Programmer Handset

Using the Programmer Handset, enter the TEST MENU. See the section **Traction Motor Controller**

and Handset for your lift truck for instructions. Check the MODE A INPUT and the MODE B INPUT. See Table 3 for the correct inputs.

TABLE OF CONTENTS

General	1
Principles of Operation	2
General	2
Transistor Motor Controller	3
Basic Controller Operation	5
Field Effect Transistor (FET).....	5
Motor Circuit That Operates With Pulses	5
Induction Current From Motor	7
Plugging	8
Control Circuit.....	9
Static-Return-To-Off (SRO) Function.....	9
Thermal Protection Function.....	10
Low Voltage Protection Function.....	10
Current Limit Protection Function	10
Power Circuit.....	10
Sequence of Operation	12
Key Switch	12
Brake Switch.....	12
Control Circuit	12
FWD/REV Switch Closed	12
Forward Contactor Energized.....	12
Gate Pulse to FETs	12
FETs ON for Time of Gate Pulse	12
Gate Pulse Removed.....	12
Induction Current Flows Through Motor and Flyback Diode.....	20
Plugging	20
Checks.....	22
Checking Contactor Coil.....	22
Checking Transistor Controller	22
Checks With Controller Installed.....	23
Bench Checks	25
Accelerator Potentiometer Checks and Adjustments.....	26
Adjustments	27
Plugging Adjustment.....	28
Acceleration Adjustment	28
Current Limit Adjustment.....	28
Repairs.....	28
Contactors	28
Replace	30
Curtis Contactor Parts, Replace	30
GE Contactor Parts, Replace	30
Controller, Replace	32
Accelerator Potentiometer and Control Switches, Replace and Adjust.....	32
Troubleshooting.....	32
General.....	32
General Procedures	33
Fault Procedures.....	33

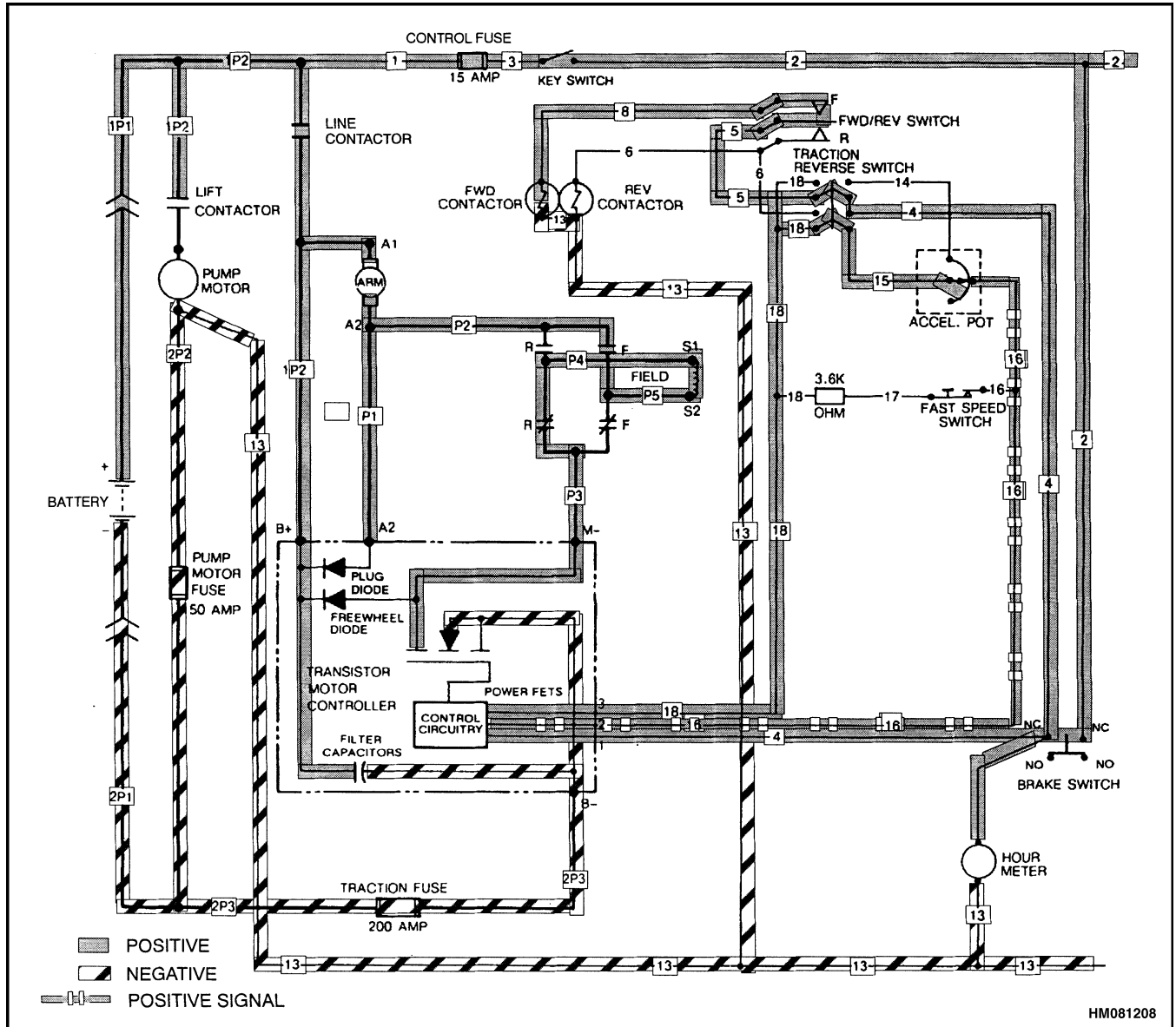

NOTE: W/B40-60XL SHOWN. OTHERS SIMILAR.

Figure 19. Sequence of Operation - FETs OFF

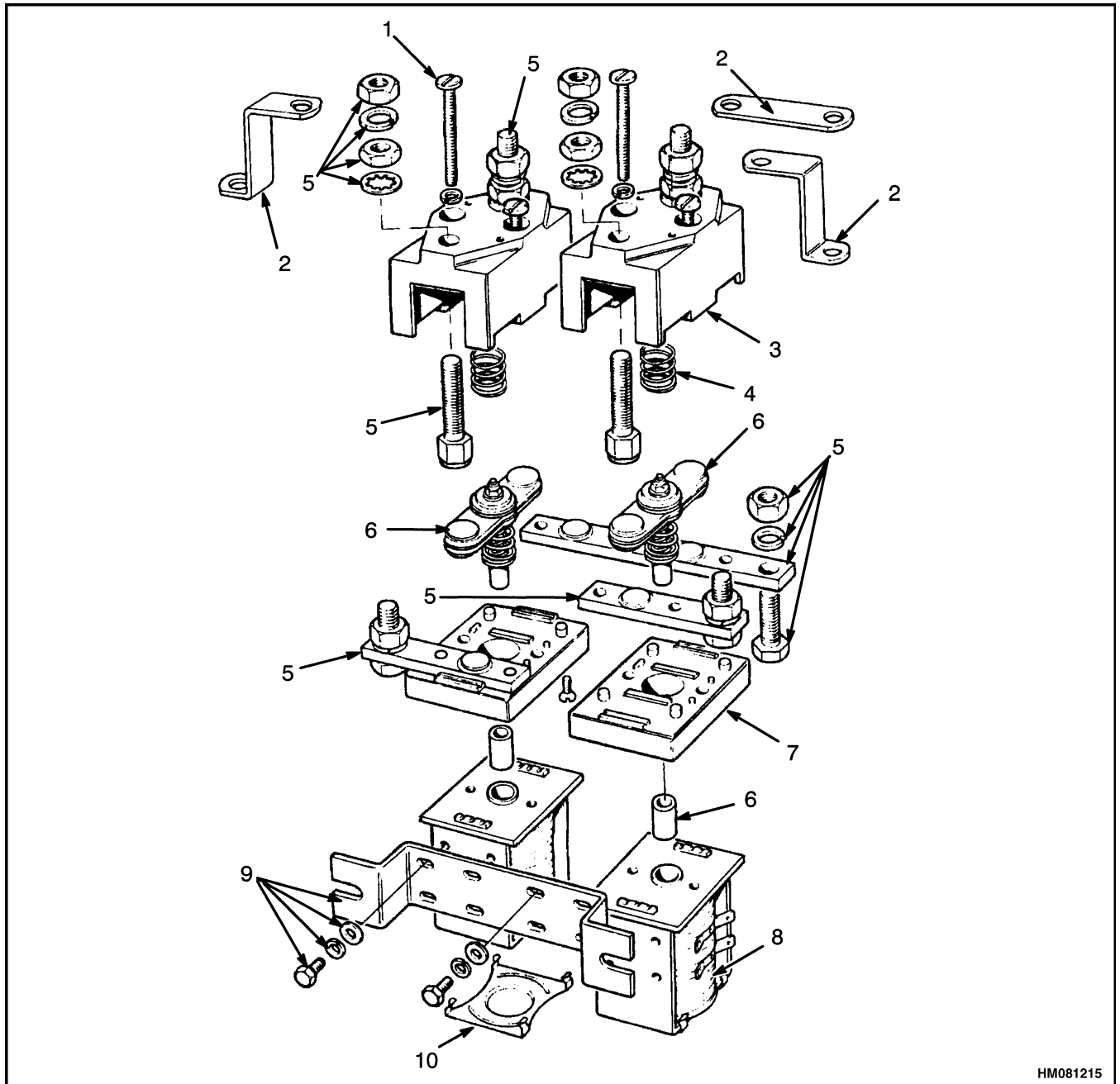

HM081215

NOTE: THE POWER CONNECTIONS FOR THE FIXED CONTACTS CAN BE DIFFERENT THAN SHOWN.

- | | |
|--|-------------------|
| 1. SCREW | 7. COVER BASE |
| 2. BUSS BAR | 8. COIL AND FRAME |
| 3. COVER | 9. MOUNT BRACKET |
| 4. SPRING | 10. ARMATURE CAP |
| 5. FIXED CONTACTS | |
| 6. PLUNGER ASSEMBLIES AND MOVABLE CONTACTS | |

Figure 26. Forward and Reverse Curtis Contactor Assembly

Table 2. Fault Codes and Display Messages for R30XMS2 Only

Code	ND	Display	Description	Items to Check if Code is Displayed
		SlackChn	Slack Chain circuit open	*Chains slack (carriage hung up on lowering)? *Slack chain switches functioning *Wiring between 1310 and slack chain switches
		SideGate	Side Gates up	*Side Gate switches functioning *Wiring between 1310 and side gate switches
		HornOpen	Horn disconnected (Open circuit)	*Horn (bench test for function) *Wiring to horn
		BrakOpen	Brake disconnected (Open circuit)	*Brake coil (bench test) *Wiring to brake
		LowrOpen	Lowering Valve disconnected (Open circuit)	*Lowering valve (bench test) *Wiring to lowering valve
		TractErr	Misc. traction error	*Wiring to 1243
		Foot Sw	Foot Switch off while requesting traction or hoist	*Foot switch *Wiring to foot switch
		Low Batt	Low Battery warning, lift cutout	
		LiftLimt	Lift Limit reached	
		LowrLimt	Lowering limit reached	
2041	5		Traction-Battery Undervoltage	
2042	5		Traction-Battery Overvoltage	
2043	5	TractHot	Traction: Thermal Cutback	*Worn load wheels, pushing loads, operation with low battery
2301	6	Str Crnt	High current	*Mechanical binding of MDU

**CAUTION**

The electrical system on this truck utilizes many control-level circuits (low voltage and current), which may be disturbed by contamination, wear or damage at the electrical connections. When investigating problems or fault codes, it may be beneficial to first check and clean/repair all connections in the affected circuit. The use of dielectric grease is recommended for all AMP and Molex electrical connectors when operating in adverse environments (freezers or dirty areas).

**CAUTION**

The fault detection software and circuits of the traction controller (Curtis 1243) are sensitive to abrupt changes in currents and voltages. Controller fault codes may not necessarily indicate a defective truck component or controller. Fault codes may be generated in response to extreme operating conditions such as potholes or very low battery levels.

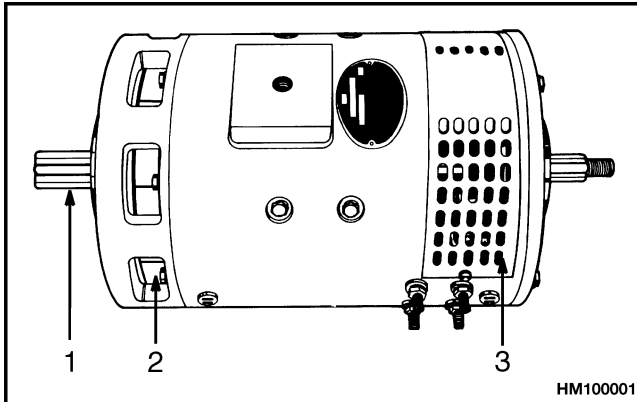

- | | |
|------------------------------|----------------|
| 1. ARMATURE
(DRIVE) SHAFT | 2. COOLING FAN |
| | 3. BRUSH COVER |

Figure 1. Traction Motor

WARNING

Compressed air can move particles so that they cause injury to the user or to other personnel. Make sure that the path of the compressed air is away from all personnel. Wear protective goggles or a face shield to prevent injury to the eyes.

NOTE: Vacuum cleaning, when possible, is the recommendation of manufacturers of electric motors. The use of compressed air can send dirt particles into the bearings and other areas of the motor that can cause possible damage.

- Remove brush covers at rear of motor. See Figure 2. Wear eye protection. Use a vacuum cleaner or compressed air to remove dirt and brush dust from commutator area.

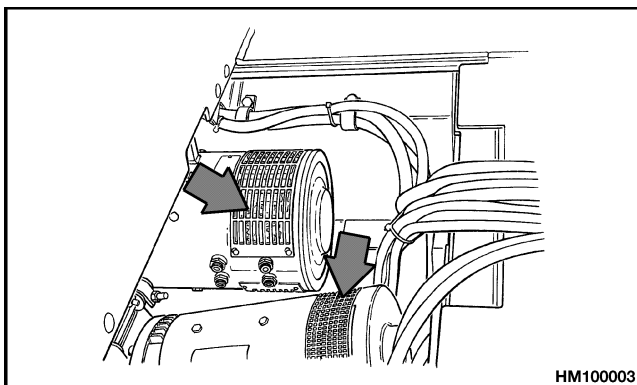

Figure 2. Brush Cover Removal From Motor

- Remove and inspect brushes for damage or uneven wear. Replace all brushes if any brush is worn or damaged. The brushes must be at least half their original length. Move brush springs away from top of each brush and pull brushes from their holders to inspect surface that rides on commutator. See Figure 3. That surface must have the same shape as the commutator and must not have cracks or defects. Some brushes have wear sensor wires attached, even if they are not connected to an indicator. Replace these brushes if brushes are worn enough to see sensor at commutator end of brush.
- Inspect commutator surface. See Table 1 and Table 2. Carefully rotate armature. **DO NOT** damage commutator if you use a tool to rotate armature.

The commutator wears slowly in normal service. The mica must be cut below the surface of the commutator bars after a long service period or after a commutator has been turned in a lathe.

A commutator that has been in service will have a smooth and polished surface with a darker brown color where it rotates under the brushes. A variation of color on the commutator surface between light brown and darker brown is normal. The surface condition is the lubrication between the commutator and the brushes. The brushes will wear rapidly if this surface condition does not develop during the first 6 to 10 hours of operation after a commutator with a new surface is installed. If the commutator has deep grooves, rough edges of the bars, or a few bars that are black or raised above the others, the motor must be removed for service.

- Inspect white or gray insulation (mica) between commutator bars. The mica must not touch the brushes or the brushes will wear very rapidly.
- To replace a brush set, remove screw that holds brush wires to bus. Pull brush end of springs from brushes, and pull brushes from holders. Lift brush springs away from holders, and install new brushes so brush commutator surface fully touches commutator. Make sure the springs are pushing on each brush. Install and tighten screws for brush wires and bus connectors.

Motors Repair

DISASSEMBLE

See the **Master Drive Unit** section or the **Frame** section for your lift truck for instructions on the removal and installation of the traction motor.

See the **Hydraulic System** section for instructions to remove and install the hydraulic pump and motor.

See the Brush and Commutator Inspection and Brush Replacement in this section for more information on these components of the motor.

Traction Motor and Hydraulic Pump Motor

NOTE: It is recommended that the bearings and the seal be replaced every 3,000 hours or 36 months, whichever comes first.

1. Clean outside surfaces of motor before disassembly. See Figure 8, Figure 9, and Figure 10. Put motor on its commutator (brush) end on a bench. On hydraulic motor assemblies, make index marks on pump and motor. Make index marks on end frames of motor and field frame so correct assembly is possible.
2. On hydraulic motor assemblies, remove two cap screws that fasten pump to pump motor. See Figure 11 or Figure 12. Remove pump. Put an index mark on armature shaft at the position of the coupler hub for correct assembly. Remove coupler hub from armature shaft by loosening setscrew and sliding hub off shaft and key. Do not lose key.
3. Remove brush cover. Remove brushes and spring assemblies.
4. Remove hex head screws from commutator end of motor. Carefully slide end frame from motor and armature shaft. Do not damage parts. A puller is frequently necessary to separate end frame from field frame.



CAUTION

The drive end frame and the armature are heavy components. Work carefully so the field coils, pole pieces, and armature are not damaged during disassembly and assembly.

5. Remove screws that fasten drive end frame to field frame. Remove end frame and armature.

Use a plastic or rubber hammer as necessary to loosen end frame.

6. Remove drive end frame from armature.

If the brush holder (1) must be loosened or removed from the end frame for repairs, the brush holder must be installed again in the same position. See Figure 7. Make alignment marks between the brush holder and the end frame before the brush mounting plate (4) is released. The brush holder must be installed again in the same position.

If a new brush holder must be installed, there will not be an alignment mark on the new brush holder. Make an alignment mark on end frame with a reference point on brush holder that must be removed. Install new brush holder so reference point and alignment mark are aligned. The new brush holder must be installed in the same position as the old holder so the timing will be correct.

7. Remove screws that fasten brush holder assembly to commutator end frame.
8. Disassemble components of motor as necessary to make repairs.

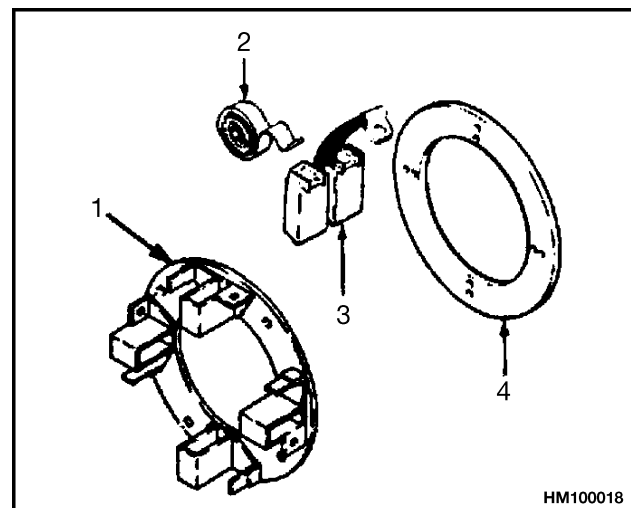

- | | |
|-----------------|-------------------------|
| 1. BRUSH HOLDER | 3. BRUSH |
| 2. BRUSH SPRING | 4. BRUSH MOUNTING PLATE |

Figure 7. Brush Holder and Mounting Plate

PROBLEM	POSSIBLE CAUSE	PROCEDURE OR ACTION
Grooves the width of the brushes (see Table 2).	Operation in a dirty or abrasive environment.	Clean commutator more frequently.
	Wrong type of brushes for this motor and operation.	Replace brushes with correct type.
	Brush pressure is too high.	Adjust brush pressure.
Copper drag occurs when copper from the commutator is pulled into the slot between the commutator bars. This problem will cause a short circuit between the commutator bars (see Table 2).	Operation in a dirty or abrasive environment.	Clean commutator more frequently.
	Brush holder is not correctly adjusted electrically for the motor.	Adjust brush holder.
	Wrong type of brushes for this motor and operation.	Replace brushes with correct type.
	Brush pressure is incorrect (too high or too low).	Adjust brush pressure.
Electrical burns on commutator bars on opposite sides of the commutator (see Table 2).	Open armature winding.	Replace armature.
	Motor has been stalled.	Use correct operating techniques.
Copper wears rapidly at the edge of the commutator bars (see Table 2).	Operation in a dirty or abrasive environment.	Clean commutator more frequently.
	Wrong type of brushes for this motor and operation.	Replace brushes with correct type.

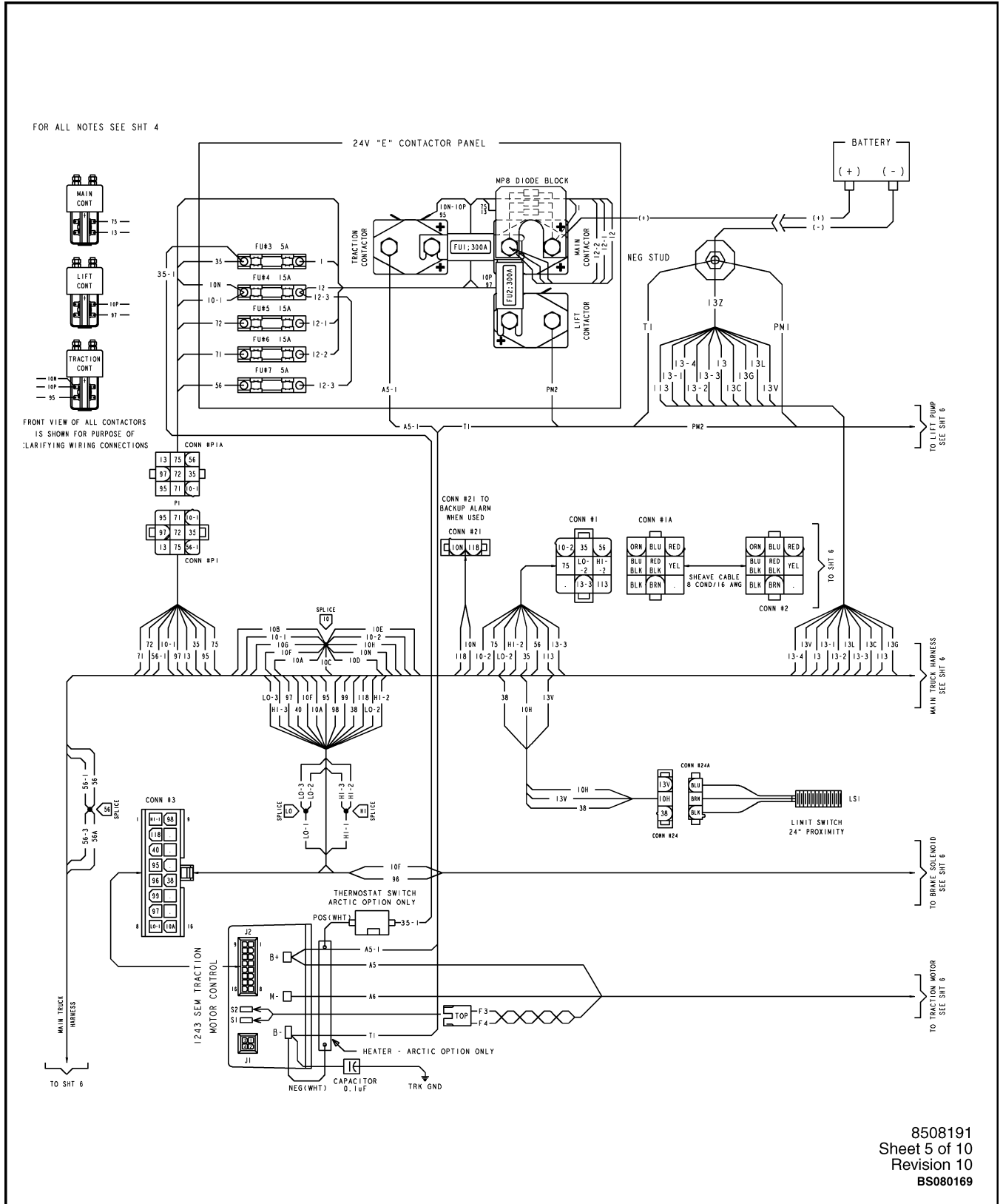

Figure 5. 24V STD/Guidance CAN Bus EPS IV SEM Wiring Diagram

3. Install washer and nut. Torque nut to 12 N•m (9 lbf ft). Loosen nut to first alignment position and install a new cotter pin.
4. Install springs between coil and armature.
5. Install hollow spacers through armature, engaging screw holes in coil. Turn hollow spacers clockwise two or three revolutions.
6. Position three washers on the capscrews and install capscrews through coil into hollow spacers.
7. Install brake assembly onto mounting flange.
8. Adjust air gap. See Adjust (C174 and F118).

ADJUST (D174 AND G118)



WARNING

Before proceeding, be sure the truck is on level ground. If there is even a slight incline, block the tire to prevent movement of the truck.

For the following instructions, see Figure 3.

NOTE: For the D174 and G118 lift trucks, the new brakes are preadjusted at the factory for the correct air gap of 0.2 to 0.4 mm (0.008 to 0.016 in.). The air gap is the distance between the brake coil and the armature when the brake is de-energized. As the brake wears, the air gap increases. When the air gap exceeds 0.4 mm (0.016 in.), the brake should be adjusted. Adjustment is also required when the friction disc is replaced. If the friction disc is worn, damaged, or broken, it should be replaced.

1. Unplug brake cable from truck wiring harness.
2. Remove four capscrews (15, Figure 3) and carefully remove brake assembly from top of the motor housing. The brake hub can be left on motor shaft.
3. Turn brake over and place it on a bench.
4. Measure air gap to determine how many shims must be removed to bring gap back into adjustment.
5. Loosen three brake assembly socket head capscrews (10, Figure 3) but do not remove them entirely.

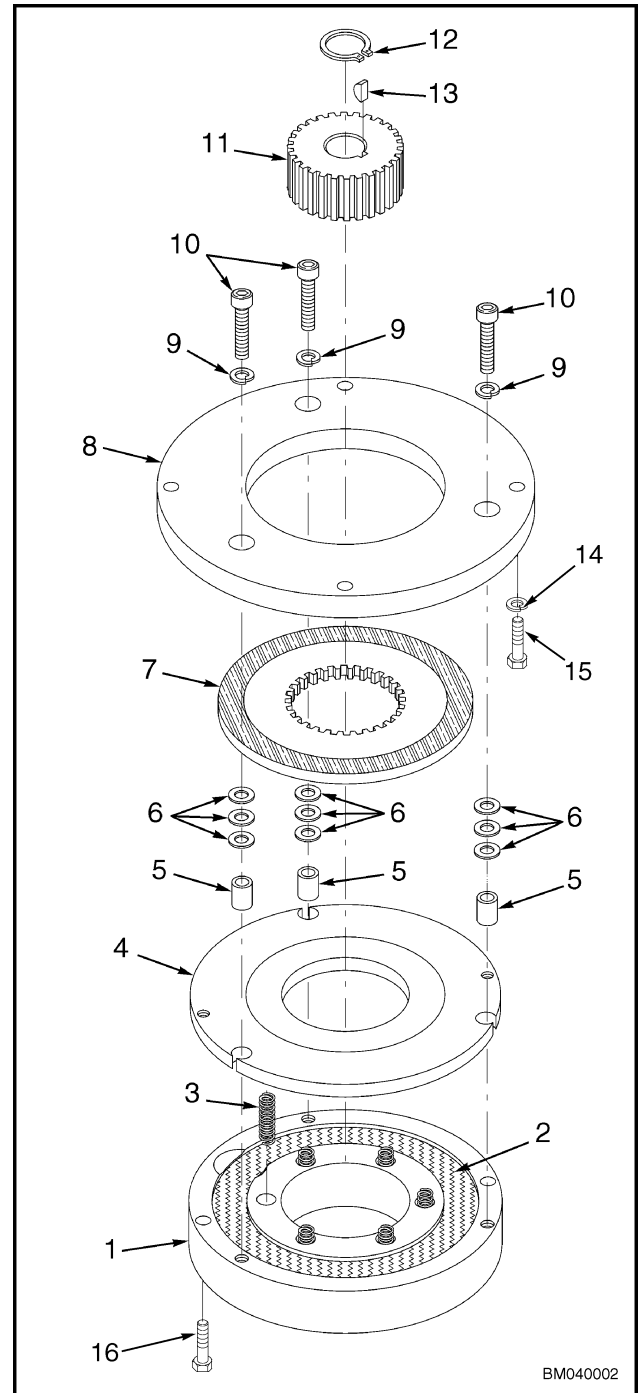

- | | |
|------------------|------------------|
| 1. MAGNET BODY | 10. CAPSCREW |
| 2. COIL | 11. HUB |
| 3. SPRING | 12. SNAP RING |
| 4. ARMATURE | 13. WOODRUFF KEY |
| 5. HOLLOW SPACER | 14. LOCKWASHER |
| 6. SHIM | 15. CAPSCREW |
| 7. FRICTION DISC | 16. MAINTENANCE |
| 8. ADAPTOR | CAPSCREW |
| 9. LOCKWASHER | |

Figure 3. Electric Brake (D174 and G118)

TABLE OF CONTENTS (Continued)

This section is for the following models:

R30XMS2 [D174]

CONTROLLER REMOVAL

Before replacing the traction controller, you will have to perform an erase memory procedure on the 1310 controller. If the memory is not erased, you could have slow speed issues.

Using the setup instructions, scroll to the erase memory message "Erase Mem", and follow the instructions to erase the memory. Reestablish the unit's parameters by using the setup instructions.

The 1310 controller will be reconfigured with the correct data for the new traction controller.

1. Move lift truck to a safe, level area. Turn the key switch to the **OFF** position and remove the key. Put a **DO NOT OPERATE** tag on the multi-function control handle. Put blocks under drive wheels to keep lift truck from moving. See **Periodic Maintenance** 8000 SRM 924 - How To Put A Lift Truck On Blocks.

WARNING

Disconnect the battery and separate the connector before opening the compartment cover or inspecting/repairing the electrical system. If a tool causes a short circuit, the high-current flow from the battery can cause a personal injury or property damage.

2. Disconnect and separate battery connector.
3. Remove fasteners retaining chassis cover, unplug flashing light, and remove cover.
4. Unplug connector from traction motor controller. Tag and disconnect wires to terminals.
5. Remove three capscrews and lockwashers and carefully remove controller from lift truck.

INSTALL

1. Make certain the mounting surface for controller is clean. There should be no dirt between the frame and the controller. Apply heat-conductive grease to bottom of controller. Align controller in lift truck with holes on frame and install lockwashers and capscrews; then tighten capscrews.
2. Connect wires and cables to the same terminals as identified during the removal procedure. See **Diagrams** 8000 SRM 923.

3. See Setup in this section.

LOW-VOLTAGE PROTECTION FUNCTION

This function protects the controller and the battery. The controller will not operate correctly if there is not a minimum voltage from the battery. The battery current drain increases as the battery voltage decreases. Too large a battery drain will damage the battery. If the battery voltage is low, the control circuit will decrease the ON TIME of the pulses to decrease the current drain. The battery can still operate the lift truck to move it for battery charging or replacement.

NOTE: The checks require a voltmeter with a meter movement. Most digital meters will not operate correctly for some of these checks. Specific checks require additional equipment.

CHECKING CONTACTOR COILS

WARNING

Disconnect the battery and separate the connector before opening the drive unit compartment or inspecting or repairing the electrical system. If a tool causes a short circuit, the high-current flow from the battery can cause a personal injury or property damage.

WARNING

Some checks require the battery to be connected. DO NOT connect the battery until the procedure tells you to connect the battery. Make sure the drive wheel is raised to prevent truck movement and possible injury. Raise the drive wheel as described in the Operating Manual or the Periodic Maintenance section of the Service Manual.

Check the main contactor coil with an ohmmeter. A suppressor diode is connected across the coil terminals. The diode will cause the ohmmeter to indicate a difference in resistance in one direction. Reverse the probes of the ohmmeter to the opposite terminals and measure the resistance. Use the highest resistance indication. Replace the coil if the resistance readings are a short circuit in both directions or if there is an open circuit in both directions. Make sure the coil wires are connected again to the correct terminals. Refer to Contactors, General within this manual.

Table 1. Fault Codes and Display Messages (Continued)

Code	Node or ND	Display	Description	Items to Check If Code Is Displayed
739A	1	Ht-EncErr	Height encoder error (lift/lower function called for, but encoder not incrementing/decrementing).	Use DiagDisp (Lift Hgt) to confirm height incrementing/decrementing when mast raised/lowered; if error in effect, large height value may be displayed, but it should still change when lifting/lowering.
				If displayed height does not change with fork height, check height encoder and wiring.
				Use DiagDisp (1243Inpt) to confirm proximity switch functioning when mast raised/lowered past 610 mm (24 in.).
				Check 610 mm (24 in.) proximity switch & wiring. If a wire has been pulled out of the switch at the plug, replace the switch assembly.
				After verifying correct switch and encoder function, lift forks above 762 mm (30 in.), lower fully, and restart truck to reset error.



CAUTION

The electrical system on this truck utilizes many control-level circuits (low voltage and current), which may be disturbed by contamination, wear, or damage at the electrical connections. When investigating problems or fault codes, it may be beneficial to check and clean/repair all connections in the affected circuit first. The use of dielectric grease is recommended for all AMP™ and Molex™ electrical connectors. Dielectric grease must be applied to each terminal opening to a depth of 3 mm (0.12 in.) on all AMP connectors and to 4 mm (0.16 in.) on molex connectors. Apply lubricant to mating end only.



CAUTION

The fault detection software and circuits of the traction controller (Curtis 1243) are sensitive to abrupt changes in currents and voltages. Controller fault codes may not necessarily indicate a defective truck component or controller. Fault codes may be generated in response to extreme operating conditions, such as potholes or very low battery levels.

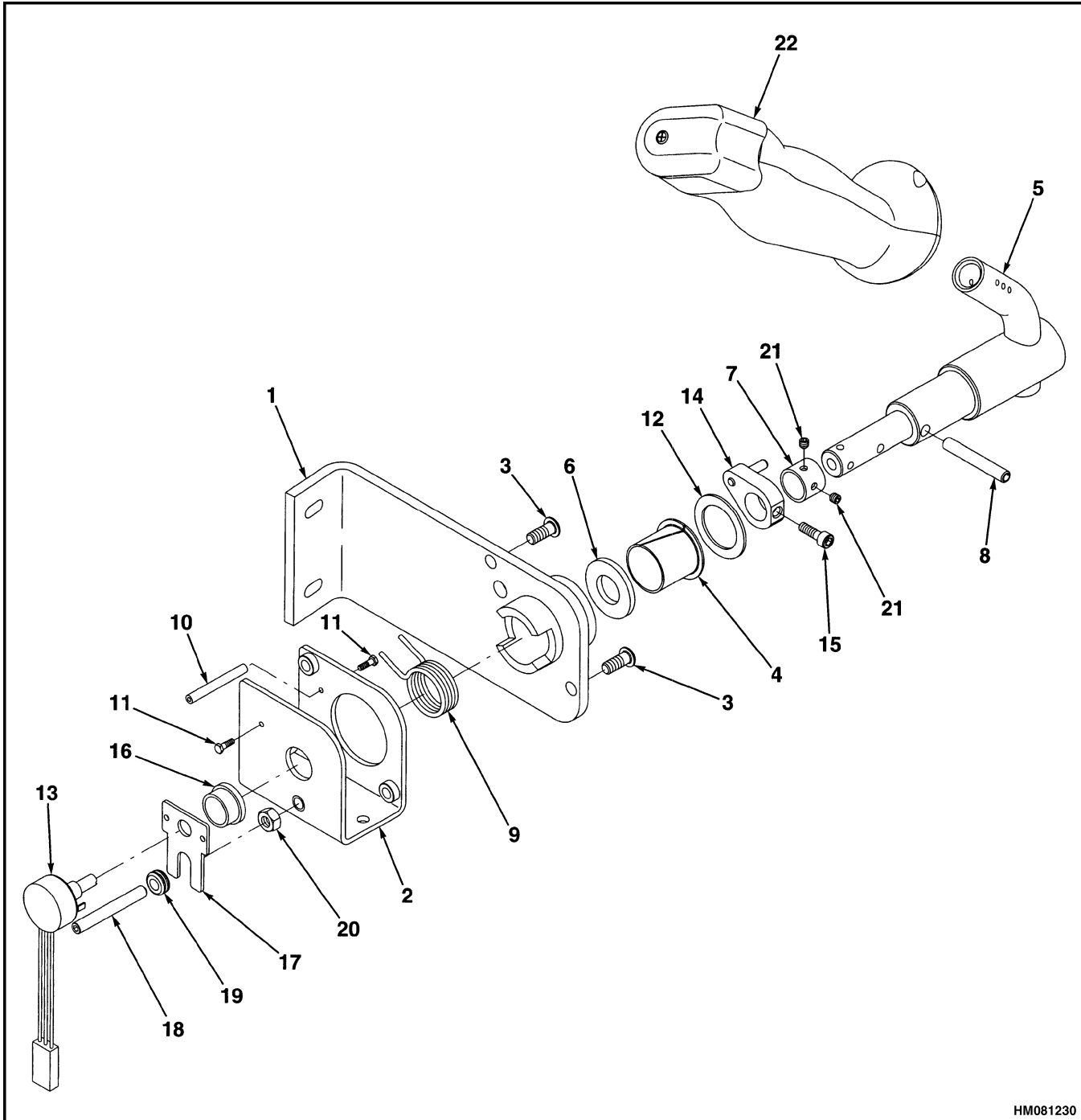

HM081230

- | | | |
|-------------------------|------------------------|--------------------------------|
| 1. SUPPORT BRACKET | 9. RETURN SPRING | 17. HALL EFFECT SENSOR BRACKET |
| 2. BRACKET ASSEMBLY | 10. THREADED STANDOFF | 18. SCREW |
| 3. BUTTON HEAD SCREW | 11. SCREW | 19. RUBBER GROMMET |
| 4. NYLON BEARING | 12. WASHER | 20. NUT |
| 5. SHAFT CONTROL HANDLE | 13. HALL EFFECT SENSOR | 21. SETSCREW |
| 6. WASHER | 14. CAM ASSEMBLY | 22. HANDLE BODY |
| 7. SPACER | 15. CAPSCREW | |
| 8. ROLL PIN | 16. BUSHING | |

Figure 4. Control Handle Mechanism

NOTE: It may be necessary to use a puller to start the end head off the bearing when removing. **DO NOT** force, or damage to the end head may result.

7. Remove screws securing brush holder assembly to end head. Inspect all parts for wear or damage and replace when necessary.

8. Reverse above to install. Be sure the new brush holders are rigid, not sloppy, and there are no loose rivets.

NOTE: **DO NOT** force end head on when installing. Lightly tap using a plastic hammer.

Drive Motor Disassembly and Assembly

WARNING

Always disconnect the battery ground cable before making repairs to prevent possible damage and injury. Install a tag on the battery terminal so that no one connects the cable on the terminal.

CAUTION

Be sure to cover the drive unit opening so debris does not enter it.

1. Disconnect battery.
2. Open drive unit compartment.
3. Tag and disconnect power cables to motor and wires to electric brake and drive motor.
4. Remove bolts mounting motor to drive unit.

WARNING

To prevent serious personal injury and possible damage to components, be very careful when using lifting devices during service and maintenance procedures

- Inspect to make sure that neither lifting strap is damaged
 - **DO NOT** subject lifting loops or lifting straps to any shock or drop loading
5. Remove drive motor with brake assembly in place using a sling and proper lifting equipment. Refer to manual for brake disassembly. See **Electric Brake** 1800 SRM 761.
 6. Clean and punch-mark (or scribe) brake assembly, drive and commutator end heads, and motor field ring housing to simplify assembly of the motor.
 7. Remove brushes and brush spring assemblies. See Figure 9.

Legend for Figure 9

- | | |
|------------------------|------------------------|
| 1. FIELD RING | 19. BRUSH ASSEMBLY |
| 2. FIELD COIL | 20. SCREW |
| 3. FIELD COIL | 21. NUT |
| 4. FIELD COIL | 22. WASHER |
| 5. FIELD COIL | 23. WASHER |
| 6. SPLICE CONNECTOR | 24. INSULATOR TERMINAL |
| 7. SCREW | 25. ARMATURE ASSEMBLY |
| 8. POLE PIECE | 26. PINION END HEAD |
| 9. COMMUTATOR END HEAD | 27. RETAINING RING |
| 10. BRUSH HOLDER | 28. BEARING |
| 11. SCREW | 29. LOCKWASHER |
| 12. SCREW | 30. LOCKWASHER |
| 13. TERMINAL LEAD | 31. SPRING |
| 14. INSULATOR TERMINAL | 32. SCREW |
| 15. INSULATOR TERMINAL | 33. WAVE SPRING |
| 16. LOCKWASHER | 34. BEARING |
| 17. WASHER | 35. SNAP RING |
| 18. NUT | 36. OIL SEAL |

FRAME

ORDERPICKER

R30XM/XMA/XMF [F118];
R30XM2/XMA2/XMF2 [G118];
R30XMS [C174]; R30XMS2 [D174]

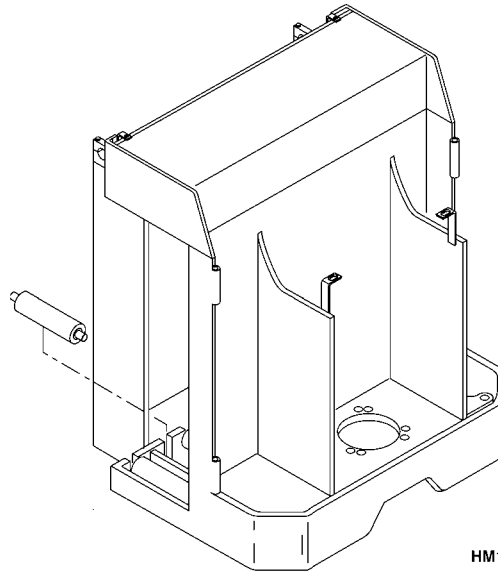

HM120349

HYSTER

TABLE OF CONTENTS

General	1
Description	1
Guide Wire Physical Installation	2
Equipment	11
Specifications.....	14
Wire Slot and Expansion Loop Specifications.....	14
Material and General Specifications	15
System II Wire Guidance Specifications.....	18
Pre-Installation Information Form	20

This section is for the following models:

C1.0, C1.3 (V30XMU) [A463, A467];
 C1.5B (V35XMU) [A464, A468];
 C1.8X (V40XMU) [A465, A469];
 C1.3 (V30ZMU) [B463];
 C1.5 (V30ZMU) [B464];
 R30ES [B174];
 R30XMS [C174];
 R30XMS2 [D174];
 N30XMH2 [C210];
 V30ZMD [D210];
 R30F/FA/FF [E118];
 R30XM/XMA/XMF [F118];
 R30XM2/XMA2/XMF2 [G118]

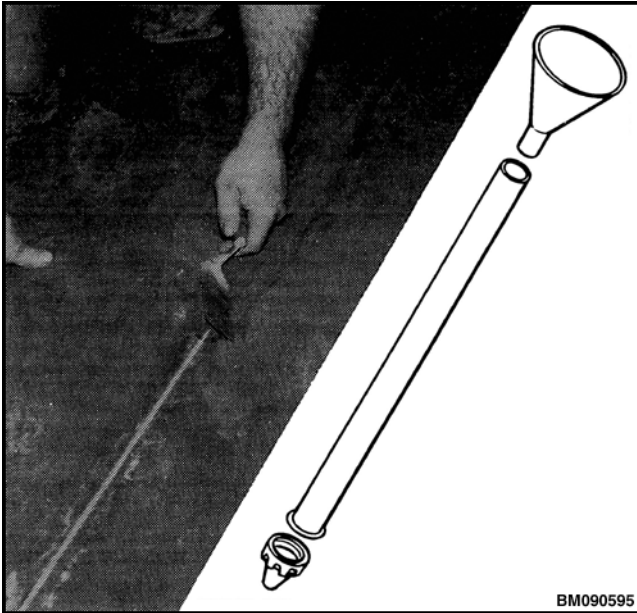

Figure 20. Grouting

29. It is extremely important for the grout to be flushed with the floor surface. Because the grout hardens rapidly, only one segment of the guide path must be grouted at one time. Before moving to the next segment, the grout must be scraped with a trowel or spatula and smoothed before it solidifies. See Figure 21. The length and timing of each segment will depend on the consistency of the grout. Have a readily available water supply with 18.93 liter (5 gal) pails and other supplies to allow a more efficient process. The 208.2 liter (55 gal) drum for the wet-dry vacuum can be partially filled with water to rinse the equipment periodically.

30. As mentioned previously, the wire driver conduit to the floor can be either a buried or surface interface. As shown in Figure 17, the wire driver is located where no pedestrian or equipment traffic will occur, so the exposed wire and the end of the conduit is simply covered with a few inches of grout.

31. The entire floor must be cleaned and swept. See Figure 22. The guide path will be almost unnoticeable in the floor. The extent of the cleanup must be mutually agreed to by the customer and the installer. Generally, a water or mopping cleanup is the customers responsibility.

32. Now the control module can be installed in its housing, and the wire continuity checked again.

Connect and check the wire driver according to **Wire Driver Manual 2200 SRM 1229**.

33. Inspect the installation with the customer so that the customer knows that the installation is satisfactorily completed, and wire continuity has been checked.

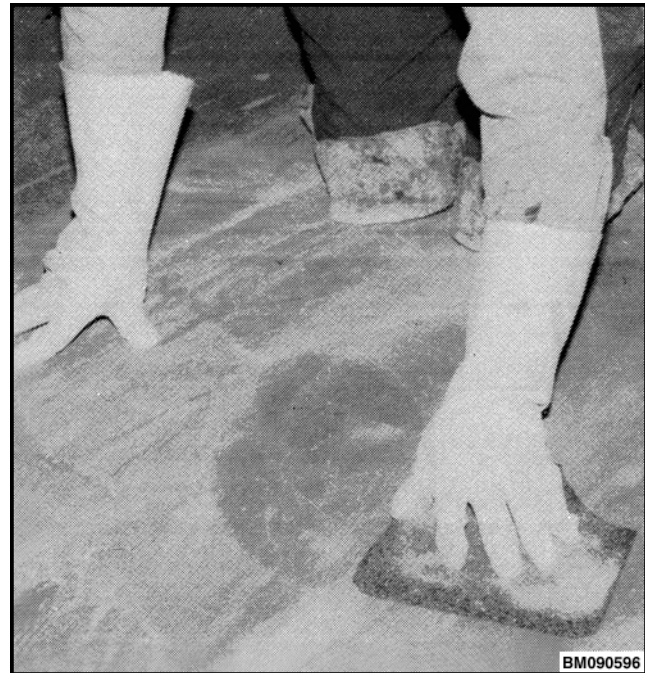

Figure 21. Smoothing Grout

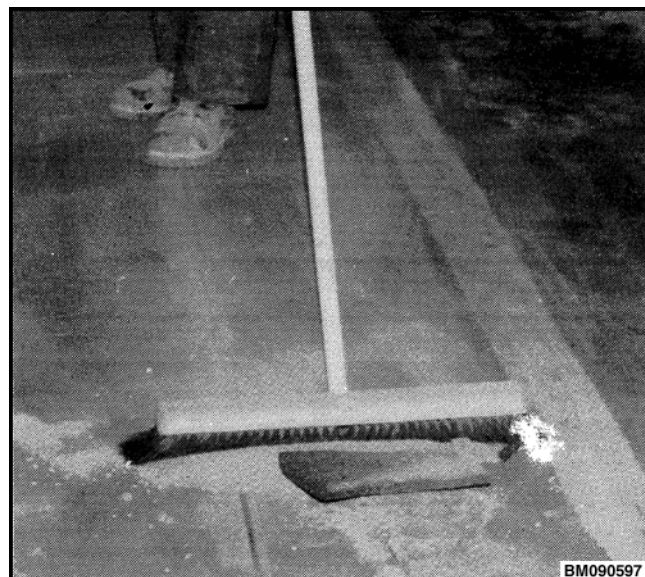

Figure 22. Sweeping Guide Path

Pre-Installation Information Form

Customer's Name (Print)			
Office Address: (For correspondence regarding installation)			
Telephone Number:			
Installation Address:			
Person to contact for access to installation site and other arrangements for the installation:			
Name(s) (Print):			
Date of Installation:			
Working Times for Installation:			
Number of customer employees helping during installation (if any):			
Amount and type of normal traffic through installation area:			
Alternate patterns for traffic during installation. If possible, note on the drawing or draw a map.			
Number of customer employees requiring ear protection:			
Determine what methods will be used to protect electrical and water lines from necessary vehicle traffic (lengths and number of "ramps").			
Determine fittings required and distance from power and water.			
Electrical fittings:			
Number and lengths of electrical cords:			
Hose fittings required:			
Number and lengths of garden hoses:			
Exhaust fans needed for gasoline exhaust from gasoline powered saw?			
Yes <input type="checkbox"/> No <input type="checkbox"/>			
Number needed:	Type:	Size(s):	
Define off-limit areas for people making wire installation:			

CLICK HERE TO **DOWNLOAD** THE COMPLETE MANUAL

- Thank you very much for reading the preview of the manual.
- You can download the complete manual from: www.heydownloads.com by clicking the link below



- Please note: If there is no response to CLICKING the link, please download this PDF first and then click on it.

CLICK HERE TO **DOWNLOAD** THE COMPLETE MANUAL

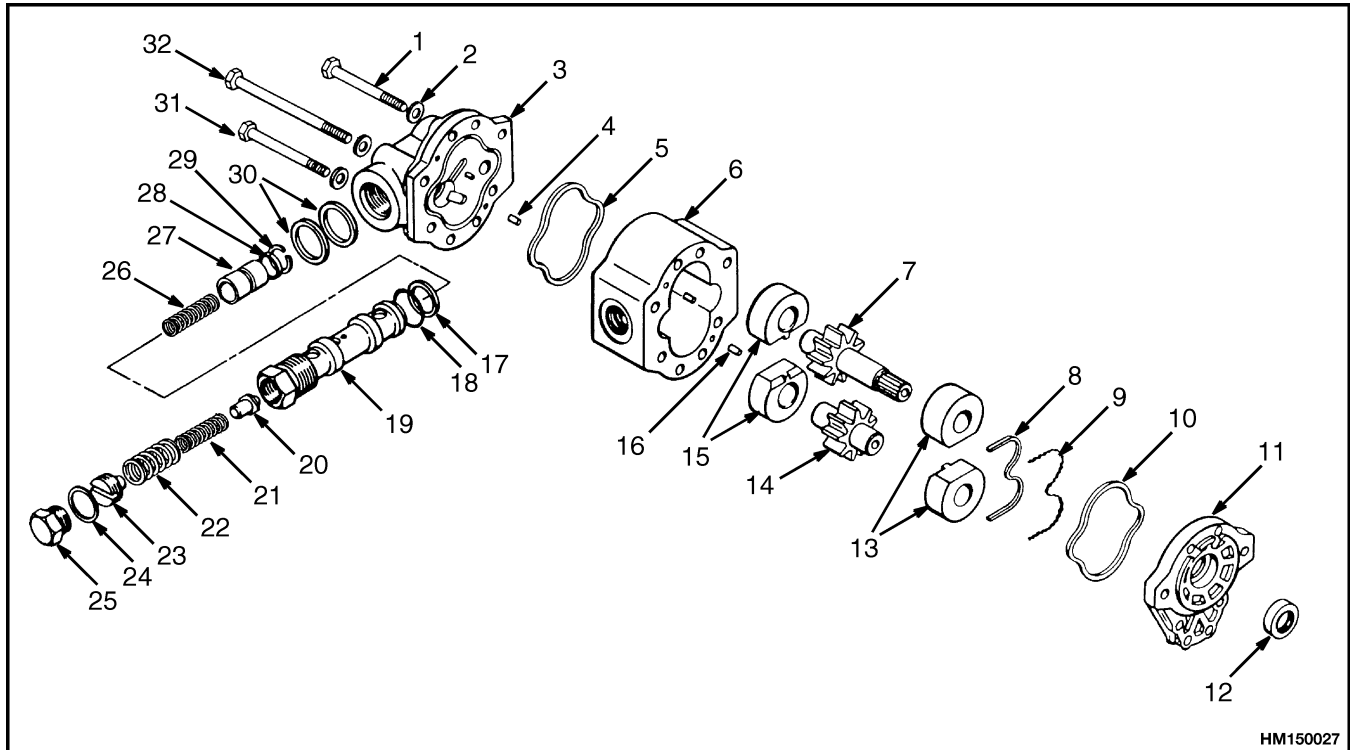

HM150027

NOTE: THERE CAN BE A VARIATION OF INTERNAL PARTS ON DIFFERENT MODELS OF LIFT TRUCKS.

- | | |
|--------------------|-------------------------|
| 1. CAPSCREW | 17. SPACER |
| 2. WASHER | 18. O-RING |
| 3. REAR COVER | 19. CARTRIDGE |
| 4. DOWEL PIN | 20. RELIEF POPPET |
| 5. SEAL | 21. SPRING |
| 6. GEAR HOUSING | 22. SPRING |
| 7. DRIVE GEAR | 23. ADJUSTMENT SCREW |
| 8. SEAL | 24. O-RING |
| 9. SEAL SPACER | 25. PLUG |
| 10. SEAL RING | 26. SPRING |
| 11. FRONT COVER | 27. FLOW CONTROL PISTON |
| 12. SHAFT SEAL | 28. O-RING |
| 13. BEARING BLOCKS | 29. SNAP RING |
| 14. DRIVEN GEAR | 30. O-RINGS |
| 15. BEARING BLOCKS | 31. CAPSCREW AND WASHER |
| 16. DOWEL PIN | 32. CAPSCREW AND WASHER |

Figure 6. Hydraulic Gear Pump Single-Stage

INSPECT

1. Inspect outside edges of gear teeth for grooves or scratches. If the edges of the gear teeth are sharp, use emery cloth to break the edges. Replace gears if there are deep grooves on the gears.
2. If the gear shafts have grooves or are worn more than 0.05 mm (0.002 in.), they must be replaced.

Wear on the seal area of the shaft indicates there is dirt in the oil or a hard seal. Inspect seal to see if it has been too hot. Look for small cracks in seal surfaces. If the seal was too hot or the wrong oil was used, the seal will be too hard or too soft. Inspect splines or key groove for damage.

PROBLEM	POSSIBLE CAUSE	PROCEDURE OR ACTION
Hydraulic pump wears faster than normal.	Dirt in the hydraulic system.	Drain hydraulic tank and clean thoroughly.
	Wrong hydraulic oil.	Drain incorrect oil and fill hydraulic tank to correct level with correct oil.
	Relief valve is set wrong or is damaged.	Adjust relief valve setting. Replace relief valve if it is damaged.
	Cavitation from restriction in inlet hose.	Clear restriction from inlet hose.
	Pump drive has a problem.	Repair pump drive.
	Pump drive is not correctly aligned.	Realign pump drive.
	Pump is not installed correctly in its mount.	Install pump drive correctly.
	Pump is operating too hot.	Check hydraulic oil level and fill to correct level.
Air in the hydraulic system.	Low oil level in hydraulic tank.	Fill hydraulic oil tank to correct level.
	Leak in inlet hose.	Replace inlet hose.
	Loose inlet fitting.	Tighten inlet fitting.
	Breather on hydraulic tank has a restriction.	Replace hydraulic tank breather.
	Supply hose is twisted or has a restriction.	Remove twist or remove restriction.
	Screen in hydraulic tank has a restriction.	Clean hydraulic tank screen.
	Pump seal is damaged.	Replace pump seal.
	Check valve in pump is damaged.	Replace check valve.
	Pump housing capscrews are loose.	Tighten pump housing screws to correct torque.
	Worn or damaged hydraulic pump.	Repair or replace hydraulic pump.

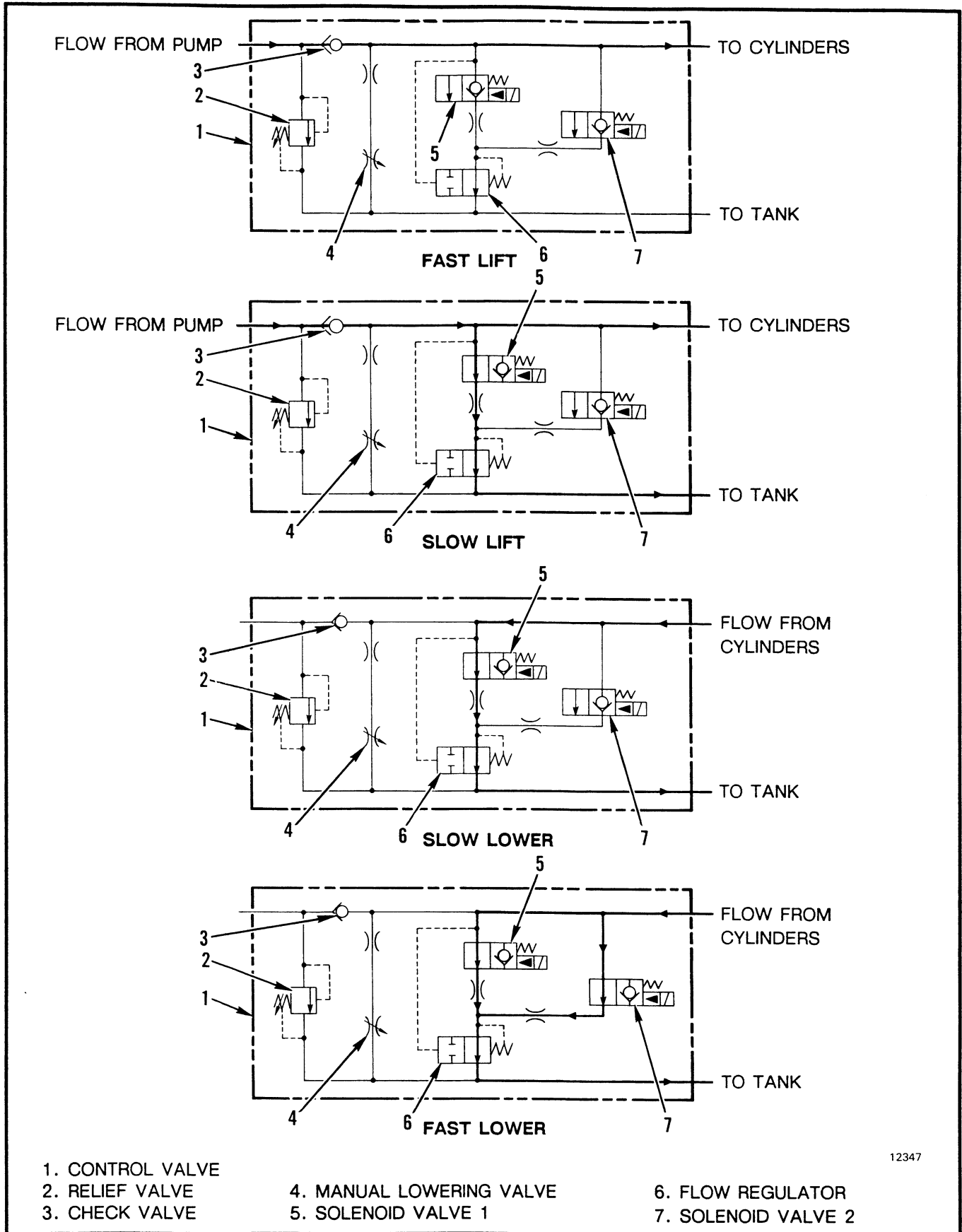
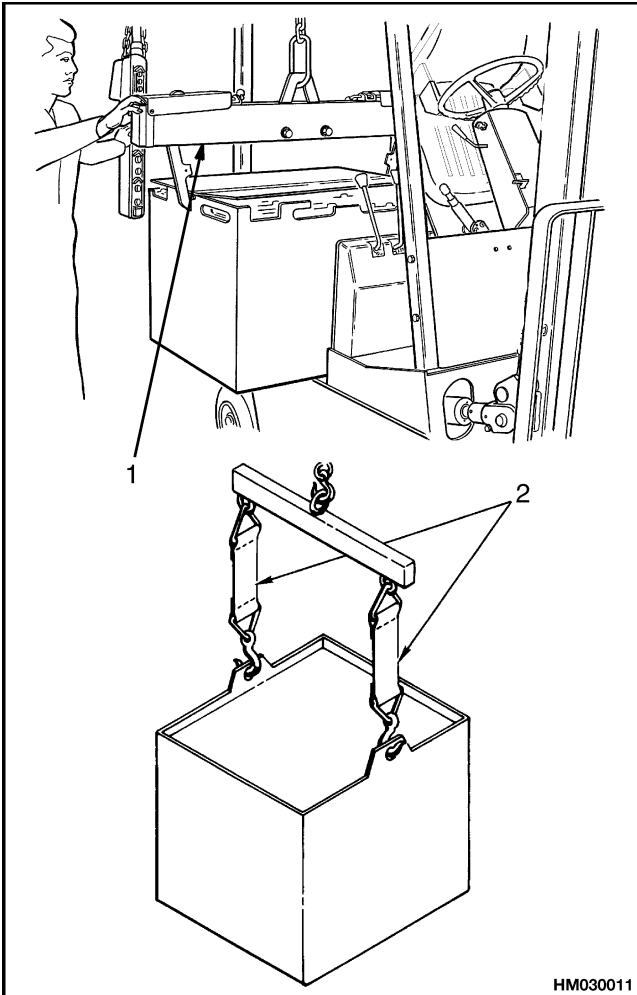

FIGURE 3. SOLENOID VALVE OPERATION, LIFTING AND LOWERING

Legend for Figure 10

- 1. INSULATED SPREADER BAR
- 2. INSULATED STRAPS



HM030011

Figure 10. Change the Battery

Battery Inspection Report									
Battery No. _____			Date _____						
Battery Type _____			Dept. Used In _____						
Serial No. _____			MFR. _____						
Reading on Charge at _____ Amperes			Date New _____						
			Charger No. _____						
CELL NO.	CELL VOLTS	POSITIVE CADMIUM	SPECIFIC GRAVITY	TEMP.	CELL NO.	CELL VOLTS	POSITIVE CADMIUM	SPECIFIC GRAVITY	TEMP.
1					21				
2					22				
3					23				
4					24				
5					25				
6					26				
7					27				
8					28				
9					29				
10					30				
11					31				
12					32				

The diagram shows a 24-cell battery grid. The cells are arranged in four rows and six columns. The terminals are numbered 1 through 24, starting from the bottom-left corner and moving right across each row, then up to the next row. A cable is connected to terminal 1.

HM030012

Figure 11. Battery Inspection Report

LIFT CYLINDERS

ALL MODELS, EXCEPT
H8.00-12.00XM (H170-280HD) [F007, G007];
H13.00-16.00XM (H300-360HD) [E019, F019];
H10.00-12.00XM-EC (H360HD-EC) [E019, F019];
H20.00-32.00F (H440-700FS) [E008];
H36.00-48.00E (H800-1050E) [D117];
H3.50-5.50XM (H70-120XM) [K005, L005];
S3.50-5.50XM, S5.50XMS (S70-120XM,
S120XMS) [E004, F004]

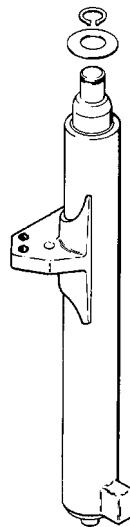

HM170082

HYSTER

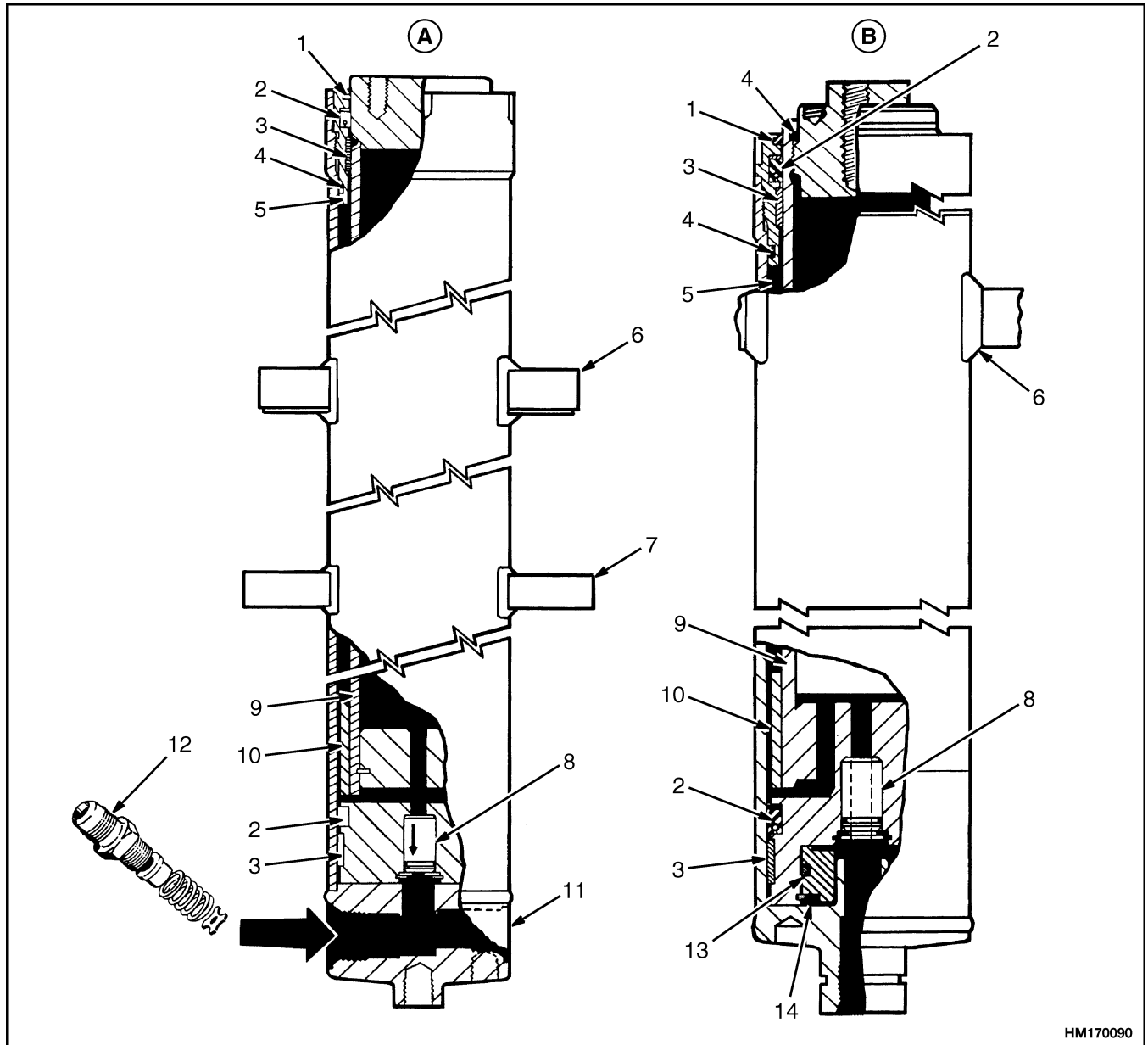

HM170090

A. MAIN LIFT CYLINDER

B. FREE-LIFT CYLINDER

- 1. WIPER RING
- 2. SINGLE-LIP SEAL
- 3. BEARING
- 4. O-RING
- 5. RETAINER
- 6. CHAIN ANCHOR MOUNT
- 7. HYDRAULIC LINE MOUNT
- 8. INTERNAL CHECK VALVE

- 9. ROD ASSEMBLY
- 10. SPACER
- 11. TO SENSING PORT FOR PHASING VALVE PRESSURE
- 12. LOWERING CONTROL VALVE (ALL CYLINDERS)
- 13. PISTON RING
- 14. CUSHION RING

Figure 6. Single-Stage Lift Cylinders

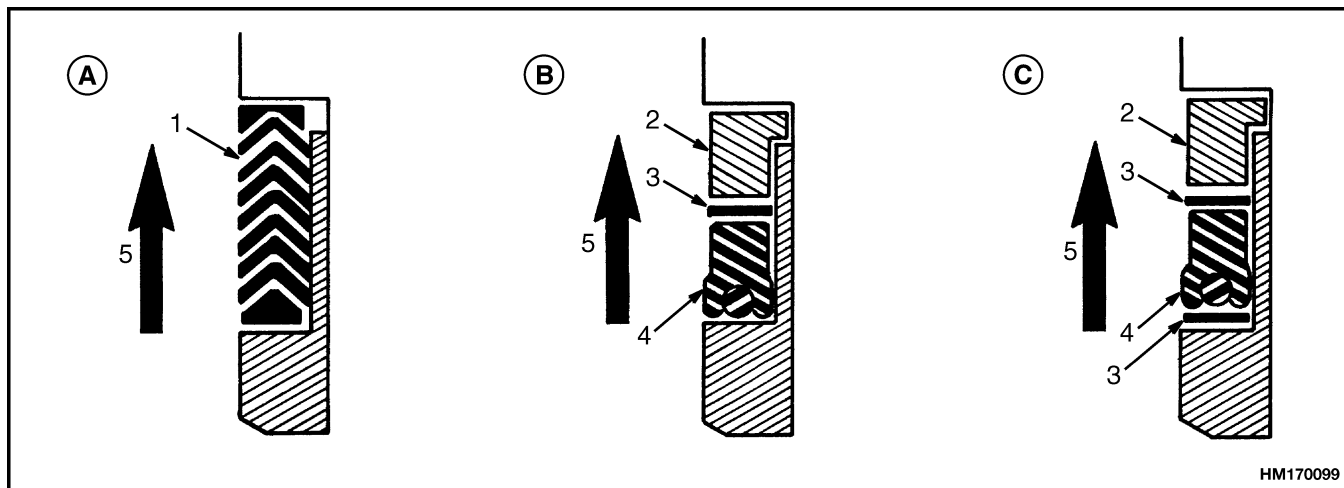

- A. MANY EARLIER PRODUCTION LIFT TRUCKS WITH LESS THAN 7000 kg (15,000 lb) CAPACITY THAT HAVE CHEVRON-STYLE PACKING CAN BE CHANGED TO SINGLE-LIP SEALS.
 B. THE PARTS ARE INSTALLED IN THE ARRANGEMENT SHOWN.
 C. IF TWO BACKUP RINGS ARE IN THE SEAL KIT, THE PARTS ARE INSTALLED IN THE ARRANGEMENT SHOWN.
- | | | |
|--------------------------|-----------------------------|------------------------------|
| 1. CHEVRON-STYLE PACKING | 3. BACKUP RING | 5. DIRECTION OF OIL PRESSURE |
| 2. ALUMINUM SPACER | 4. SINGLE-LIP SEAL ASSEMBLY | |

Figure 16. Chevron-Style Packing Replacement Seal Kits

Chevron-Style Packing Installation on Piston

STEP 1.

Lubricate the new O-ring with hydraulic oil and then install it on the piston end of the cylinder rod.

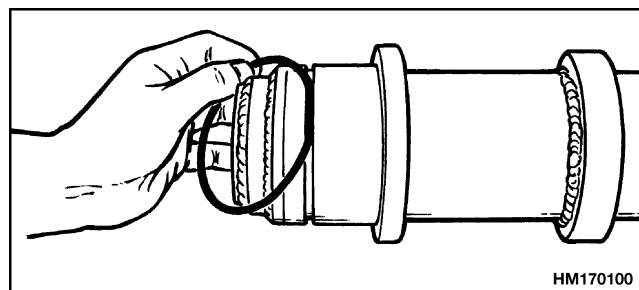

STEP 2.

Install a new packing assembly on the piston half. The packing must extend approximately 3 mm (1/8 in.) beyond the end of the piston half.

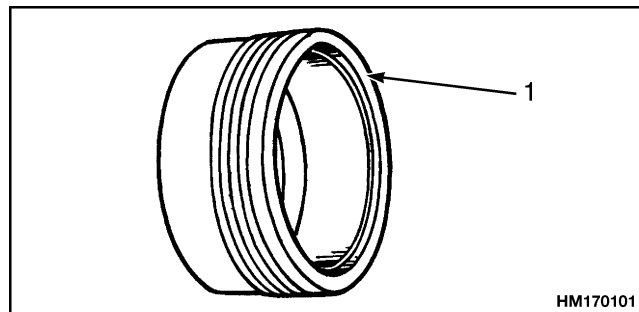

1. THIS RING MUST EXTEND 3 mm (1/8 in.) BEYOND END OF PISTON HALF.

Specifications

Table 2. Cylinder Retainer Torque Specifications and Weight Guide

Rod Diameter		Typical Outer Retainer Torque Values		Lifting Mechanism
mm	in.	N•m	lbf ft	
One-Stage Cylinders for Lift Trucks with Less than 7000 kg (15,000 lb) Capacity				
57.2	2.25	373-441	275-325	Use crane and slings with at least 500 kg (1000 lb) capacity to lift the cylinder.
63.5	2.50	203-271	150-200	
69.9	2.75	373-441	275-325	
76.2	3.00	407-475	300-350	
81.3	3.20	407-475	300-350	
88.9	3.50	475-452	350-400	
101.6	4.00	407-475	300-350	
114.3	4.50	610-678	450-500	
One-Stage Cylinders for Lift Trucks with More than 7000 kg (15,000 lb) Capacity				
108.0	4.25	Tighten retainer or packing gland nut. Oil leakage is not controlled by the torque on the retainer.		Use crane and slings with at least 1000 kg (2000 lb) capacity to lift the cylinder.
113.4	5.25			
241.3	9.50			Use crane and slings with at least 2000 kg (4000 lb) capacity to lift the cylinder.
254.0	10.00			
Two-Stage Cylinders for Lift Trucks with Less than 5000 kg (10,000 lb) Capacity				
82.6	3.25	373-509	325-375	Use crane and slings with at least 500 kg (1000 lb) capacity to lift the cylinder.
95.3	3.75	271-305	200-225	
101.6	4.00	271-339	200-250	
114.3	4.50	339-407	250-300	
122.0	5.00	407-475	300-350	
Inner retainer torque value is 122 N•m (90 lbf ft).				

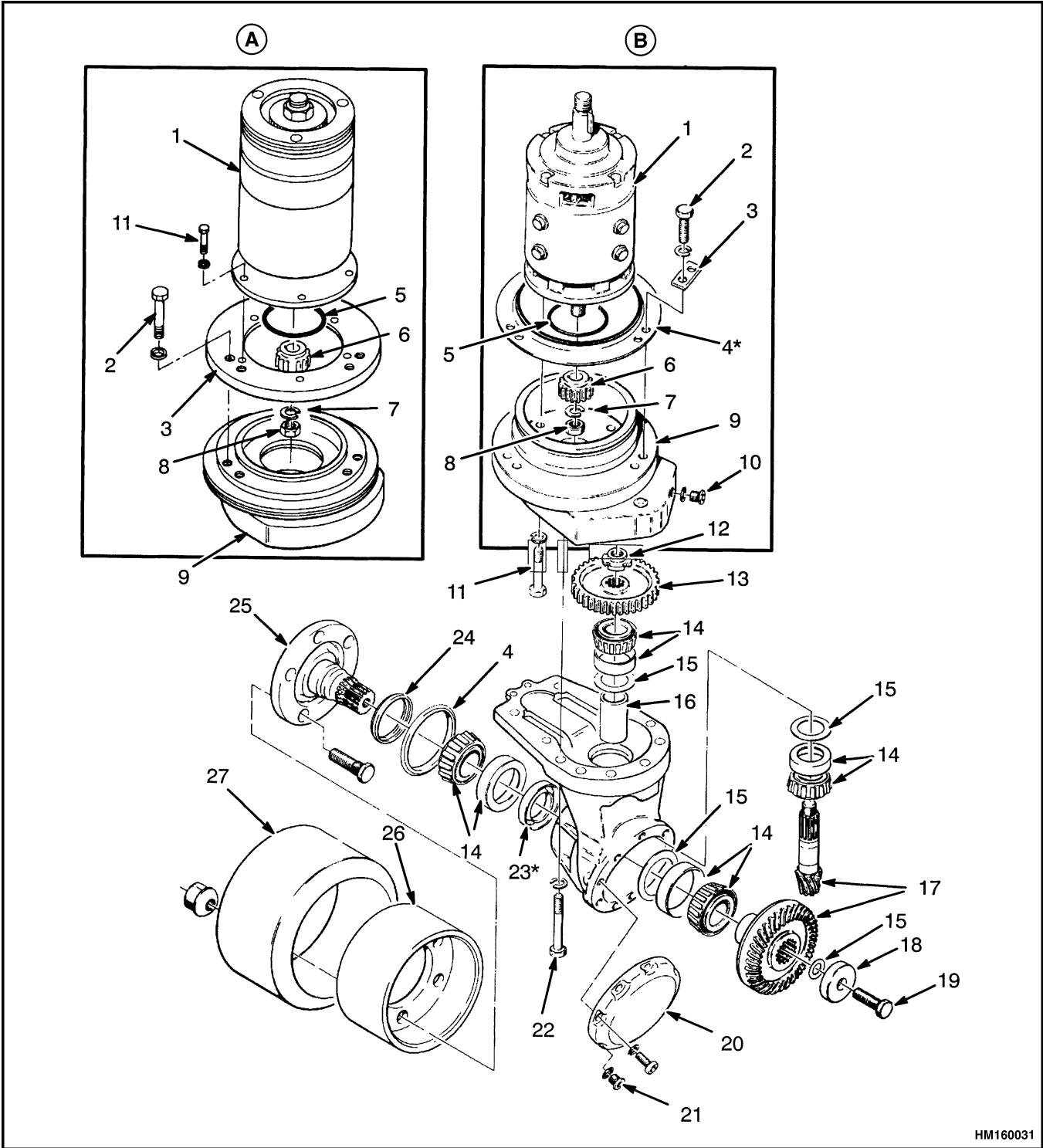
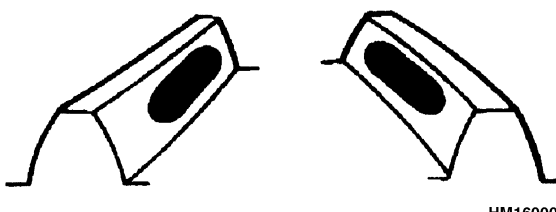
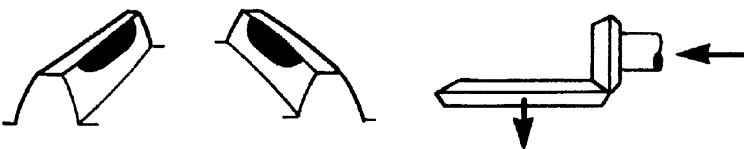





Figure 4. Master Drive Unit Parts

Table 1. Tooth Contact Pattern

<p style="text-align: center;">Correct Contact Pattern</p>  <p style="text-align: right;">HM160007</p>	<p>Step 1. Apply a colored dye or grease to approximately 12 of the teeth of the spiral bevel gear.</p> <p>Step 2. Apply a small friction load to the edge of the gear so that the gear does not turn easily. Rotate the gear one revolution by turning the large gear on the spiral bevel pinion.</p> <p>Step 3. Check the tooth contact pattern on the spiral bevel gear. Make sure that the pattern is checked on the side of the tooth where the pinion teeth apply the force.</p>
<p>Wrong Tooth Contact Pattern</p>	
<p style="text-align: center;">Tip Contact</p>  <p style="text-align: right;">HM160008</p>	<p>The spiral bevel pinion is too far from the center of the spiral bevel gear. Some movement in the direction of the arrows can be necessary. Adjust the thickness of the shim as described in the assembly procedure.</p>
<p style="text-align: center;">Base Contact</p>  <p style="text-align: right;">HM160009</p>	<p>The spiral bevel pinion is too close to the center of the spiral bevel gear. Some movement in the direction of the arrows can be necessary. Adjust the thickness of the shim sets as described in the assembly procedure.</p>
<p style="text-align: center;">Inner Contact</p>  <p style="text-align: right;">HM160010</p>	<p>The spiral bevel pinion is too far from the center of the spiral bevel pinion. Some movement of the spiral gear away from the spiral bevel pinion can be necessary. Adjust the shim sets at the spiral bevel gear as described in the assembly procedure.</p>
<p style="text-align: center;">Outer Contact</p>  <p style="text-align: right;">HM160011</p>	<p>The spiral bevel pinion is too far from the center of the spiral bevel pinion. Some movement of the spiral gear toward the spiral bevel pinion can be necessary. Adjust the shim sets at the spiral bevel gear as described in the assembly procedure.</p>

General

THREADED FASTENERS

Threaded fasteners, like bolts, nuts, capscrews, and studs, are made to specifications that describe the mechanical strength and hardness of the fastener. A fastener used in a design application is selected according to its specifications. Hyster® Company buys parts from many countries. Parts that are purchased must be to Hyster® Company standards. There are several standards used by these countries in the manufacture of threaded fasteners. Many of these fasteners are similar, but cannot be used as a direct replacement. To make sure that you have the correct fastener, order fasteners and parts through the Hyster® Parts Depot.

Service persons must use replacement fasteners that have the same specifications. Fasteners made to each specification have identification marks for that specification. This specification is commonly called "Grade" for SAE standards and "property class" for metric standards. This section describes the identification of some common fasteners.

The metric system used by Hyster® Company is described as SI (Le Systeme d'Unites or the International System of units, also called SI in all languages). The SI System of measurement is described in ISO Standard 1000, 1973. A conversion table of common measurements is shown in Table 7.

NOMENCLATURE, THREADS

The thread design is specified by a series of numbers and letters for inch and metric fasteners. See Figure 1. The diameter of the shank of the fastener is

shown first in the series [M12 = 12 mm, M20 = 20 mm (1/2 = 1/2 in., 3/4 = 3/4 in.)].

The number of threads per inch is normally not shown for inch nomenclature and only the UNC (Unified National Coarse) or UNF (Unified National Fine) is shown. This number of threads per inch is not shown because a UNC or UNF fastener has a standard number of threads per inch for a specific diameter. Metric fasteners show the number of threads per millimeter.

The length of the shank is often indicated as part of the description of a fastener. This length is shown in inches for inch fasteners and in millimeters for metric fasteners.

A capscrew will have the following description:

Metric	Inch
M12 x 1.75 x 50	1/2 x 13 UNC x 1-1/2
A B C	A B C D
A = Thread Size	A = Shank Diameter
B = Pitch	B = Number of Threads Per Unit of Length
C = Length	C = type of Thread
	D = Shank Length

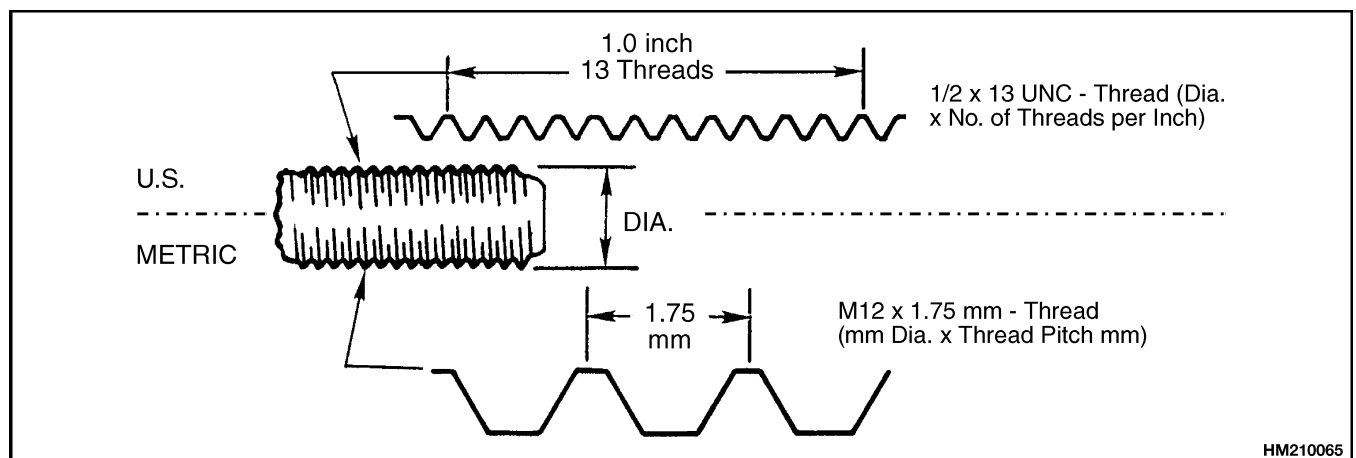
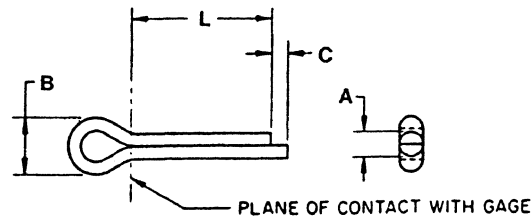

Figure 1. Thread Design

Table 9. Cotter Pin Dimensional Data

Nominal Length L	Length Range		Nominal Size - Part Numbers				
	max	min	1.00 mm (0.031 in.)	1.60 mm (0.047 in.)	2.00 mm (0.062 in.)	2.50 mm (0.094 in.)	3.20 mm (0.125 in.)
6.35 mm (0.250 in.)	7.10 mm (0.280 in.)	5.50 mm (0.217 in.)	0221870	0221875			
9.525 mm (0.375 in.)	10.5 mm (0.413 in.)	8.80 mm (0.345 in.)	0221871	0221876			
12.7 mm (0.500 in.)	13.5 mm (0.530 in.)	11.5 mm (0.453 in.)	0221872	0221877	0015200	0015211	0015221
19.05 mm (0.750 in.)	20.5 mm (0.807 in.)	18.3 mm (0.720 in.)	0221873	0221878	0015201	0015212	0015222
25.4 mm (1.000 in.)	26.9 mm (1.060 in.)	23.9 mm (0.940 in.)	0221874	0221879	0015202	0015213	0015223
31.75 mm (1.250 in.)	33.3 mm (1.310 in.)	29.2 mm (1.150 in.)			0015203	0015216	0015224
38.1 mm (1.500 in.)	40.9 mm (1.610 in.)	36.6 mm (1.440 in.)			0015204	0015217	0015225
44.45 mm (1.750 in.)	46.0 mm (1.810 in.)	42.9 mm (1.690 in.)			0015205	0015218	0015226
50.8 mm (2.000 in.)	52.3 mm (2.060 in.)	49.3 mm (1.940 in.)			0015206	0015219	0015227
57.15 mm (2.250 in.)	58.7 mm (2.310 in.)	55.1 mm (2.170 in.)				0015220	0056997
63.5 mm (2.500 in.)	65.0 mm (2.560 in.)	62.0 mm (2.440 in.)				0221894	0015229
69.85 mm (2.750 in.)	72.1 mm (2.840 in.)	68.3 mm (2.690 in.)					0015230
76.2 mm (3.000 in.)	81.3 mm (3.200 in.)	74.7 mm (2.940 in.)					0015279
88.9 mm (3.500 in.)	91.4 mm (3.600 in.)	87.4 mm (3.440 in.)					
101.6 mm (4.000 in.)	113.3 mm (4.460 in.)	98.8 mm (3.890 in.)					



EXTENDED PRONG

HM211587

General

This manual contains a Maintenance Schedule and the instructions for maintenance and inspection.

The Maintenance Schedule has time intervals for inspection, lubrication, and maintenance. The time intervals are based on a normal operation. A normal operation is considered to be one 8-hour shift per day, in a relatively clean environment, on an improved surface. Multiple shifts, dirty operating conditions, etc., will require a reduction in the recommended time periods in the Maintenance Schedule.

Some users have service personnel and facilities to perform the items listed in the Maintenance Schedule. Service Manuals are available from your Hyster lift truck dealer to help users who do their own maintenance.

Your Hyster lift truck dealer has the personnel and equipment to do a complete program of inspection, lubrication, and maintenance. Periodic maintenance will help your lift truck operate better over a longer period.



WARNING

DO NOT make repairs or adjustments unless you have both authorization and training. Repairs and adjustments that are not correct can be made on a lift truck by people without authorization and training. Repairs and adjustments that are not correct can make a dangerous operating condition.

DO NOT operate a lift truck that needs repairs. Report the need for repairs immediately. If repair is necessary, put a DO NOT OPERATE tag in the operator's area. Remove the key from the key switch.

Put the lift truck on a level surface. Lower the platform and forks, apply the parking brake, and turn the key switch to the **OFF** position. Open the access panels and check for leaks and conditions that are not normal. Clean any oil or other spills. Make sure that lint, dust, paper, and other materials are removed from the compartments.

HOW TO MOVE A DISABLED TRUCK



WARNING

To avoid personal injury or property damage, use extra care when moving a lift truck if there is a problem with any of the following conditions:

- **Brakes do not operate correctly.**
- **Steering does not operate correctly.**
- **Tires are damaged.**
- **Traction conditions are bad.**
- **The lift truck must be towed on a steep grade.**

Poor traction can cause the disabled lift truck or towing vehicle to slide. Steep grades will increase the required brake effort.

NOTE: Always remember there may be problems with more than one of the above areas of the truck. **DO NOT** tow the lift truck if you have not identified all problem areas.

The best way to move the lift truck is to use another lift truck to raise the drive tire off the ground. This will allow the lift truck to be towed or pushed around. Whatever method is used, the important thing to remember is to travel slowly.

If there is no electrical power, there is no steering and the brake will be applied. If the lift truck is inoperable, the brake will have to be released using two 1/4-20 × 1-1/2 inch bolts. Poor traction can cause the disabled lift truck or towing vehicle to slide. Steep grades will require additional brake force to stop the lift truck.

Never carry a disabled lift truck unless the lift truck **MUST** be moved and cannot be towed. The lift truck used to lift the disabled lift truck **MUST** have a rated capacity equal to or greater than the weight of the disabled lift truck. The capacity must be for a load center equal to half the width of the disabled lift truck. See the nameplate on the disabled lift truck for the approximate total weight. The forks must extend the full width of the disabled lift truck. Center the weight of the disabled lift truck on the forks and be careful not to damage the underside of the disabled lift truck. Tilt the mast back and travel slowly.

Fuses

There are seven fuses on this truck and they are all found on the contactor panel. Ratings of the fuses are shown in Table 2.

Table 2. Fuses

Fuses	Circuit	Rating
FU 1	Traction	300A
FU 2	Pump	300A
FU 3	Start Circuit	5A
FU 4	Operator Compartment Light Fan and Flashing Light	15A
FU 5	APS Power	15A
FU 6	APS Power	15A
FU 7	MCU, LS3, WGU, and Indicator	5A

Power for the APS steering motor controller is supplied by fuses FU 5 and FU 6. They are wired in parallel to provide 30 amps to the controller so that if one blows, the other may too. Without this current, the controller will be disabled. The MCU will sense that the steering controller is disabled and will not allow the drive motor to work.

All the fuses are located in the electrical compartment. See Figure 7. Remove the cover over the electrical compartment for access. The condition of some fuses can be checked by looking at them. Other fuses do not change in looks and must be checked with an ohmmeter to determine continuity. Disconnect the battery before checking fuses.

Check that the fuses are the correct sizes and are not burned. Some types of fuses must be checked with an

ohmmeter. If any of the fuses are bad, disconnect the battery before replacing the fuse.

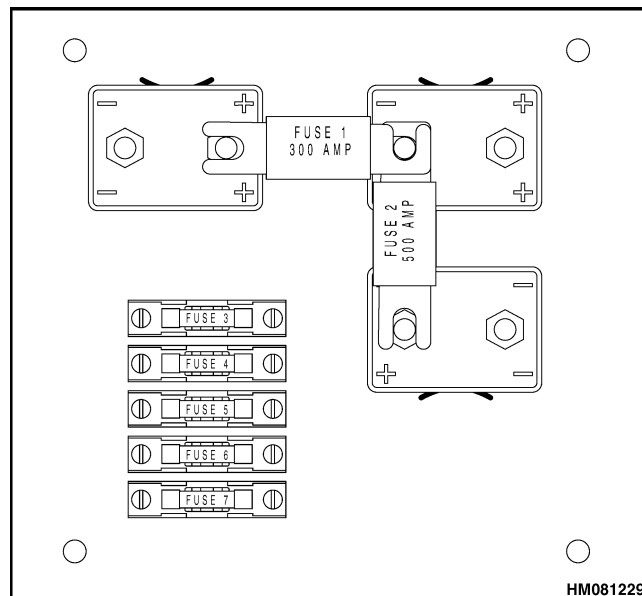

Figure 7. Fuse Locations

Switches and Direction/Speed Control

Check that the direction/speed control and the switches for Lift and Lower operate as described in Table 1 of the **Operating Manual**. Check that the foot switch and direction/speed control operate as described in the Operating Procedures section of the **Operating Manual**.

Check the operation of the power disconnect switch. The location of the switch is shown in Figure 8. Push the switch with the key switch in the **ON** position and the foot switch depressed. All electrical circuits must **NOT** operate. Move the key to the **OFF**, **START**, and **ON** positions to reset the power disconnect circuit.

NOTE: Many customers have battery chargers that can follow a program to automatically charge a battery according to recommendations of the battery manufacturer. Use the recommendations of the battery manufacturer for charging the battery.

HOW TO CHANGE THE BATTERY

General



WARNING

Batteries are heavy and can cause an injury. Use care to avoid injury. **DO NOT** put hands, arms, feet, or legs between the battery and a solid object.

To prevent personal injury and unexpected battery movement, the battery must be level when it is moving. Make sure the battery stand is on a level surface and is aligned and adjusted as described in the following procedure.

The previous warning must be observed when changing the battery.

Battery, Remove

1. Move the key switch to the **OFF** position. Use the battery disconnect to disconnect the battery.
2. Move to a position in front of the battery compartment panel on the side for the battery stand.
3. Align the battery stand with the battery so the end of the stand is against the roller frame for the battery. Adjust the capscrew legs of the battery stand so the tops of the rollers are the same height as the bottom of the battery and the rollers are level.
4. Install the battery puller on the end of the stand at the center. See Figure 14. Release the ratchet lock and attach the hook to the lifting hole of the battery.

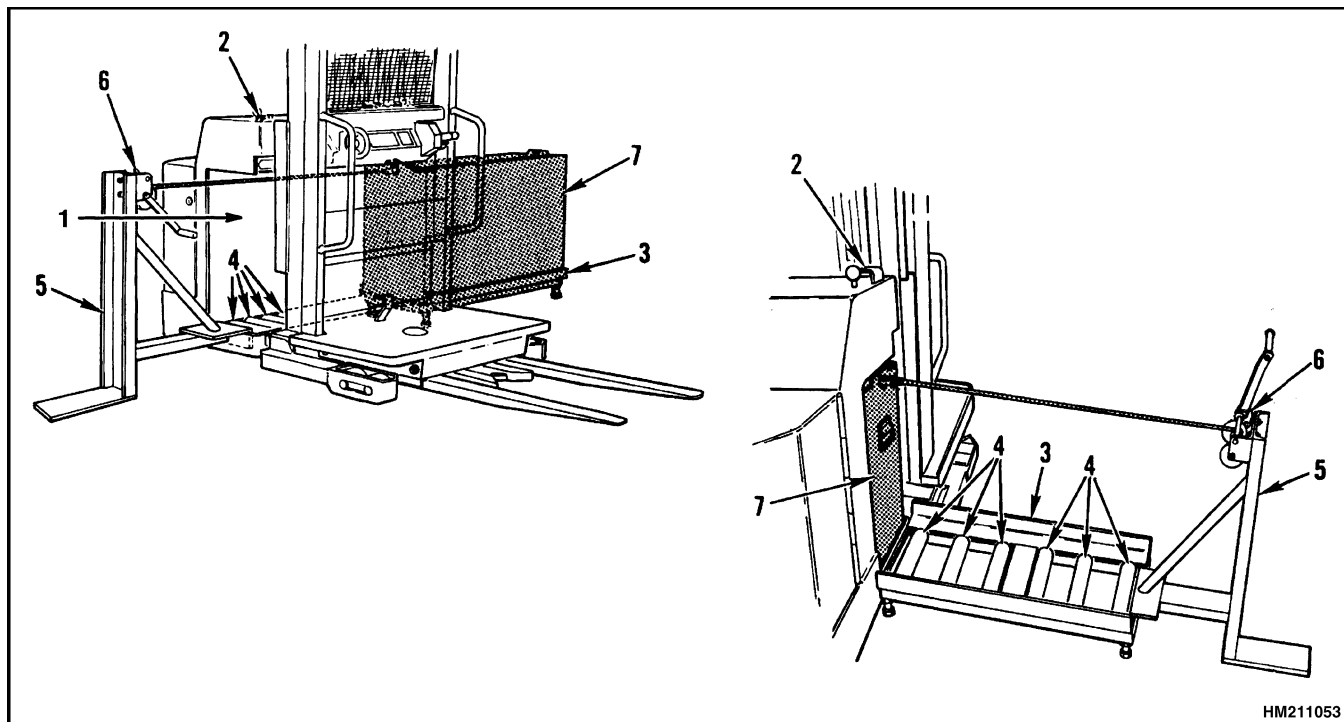

NOTE: ILLUSTRATION ON LEFT SHOWS INSTALLATION; ILLUSTRATION ON RIGHT SHOWS REMOVAL.

- | | |
|--------------------------------|-----------------------|
| 1. BATTERY COMPARTMENT | 5. BATTERY PULLER |
| 2. LATCH FOR COMPARTMENT PANEL | 6. RATCHET LOCK LEVER |
| 3. BATTERY STAND | 7. BATTERY |
| 4. ROLLERS | |

Figure 14. How to Change the Battery

If the ECM is replaced, or the settings of the dipswitches are inadvertently changed, refer to Figure 1 to set the position of the dipswitches to the factory settings.

On trucks equipped with the optional TGS System, an adjustment can be made to the settings of dipswitches 5, 6, and 7 to alter the sensitivity of the tach generator input scaling, if desired. Refer to Tach Generator Steering System, EPS III, Sensitivity Adjustment, EPS III in the Adjustments section following.

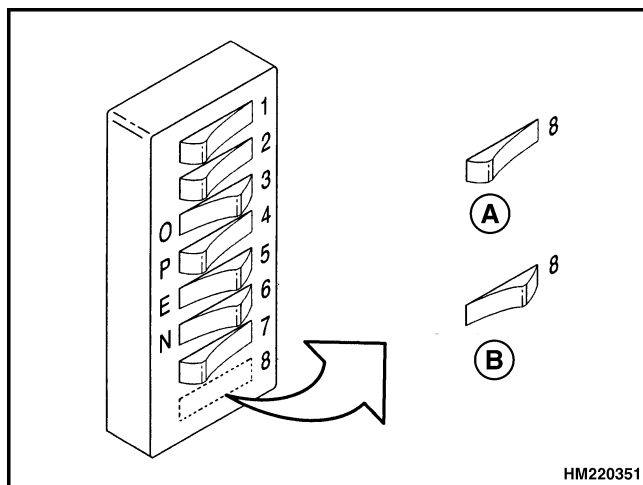

- A. SET SWITCH 8 FOR RTC STEER
- B. SET SWITCH 8 FOR TACH STEER

Figure 1. Dipswitches - Factory Setting

LED Indicators, EPS III

The ECM continuously monitors the steering system. Problems detected by the ECM are indicated by 5 LEDs. Refer to Figure 2 and Table 1. The vehicles equipped with electric steering systems are designed to stop automatically when a fault occurs. The brake relay, located in the ECM, applies the brake to stop the vehicle if a fault condition is detected.

Table 1. LED Indicators

LED 1 on (green) (with motor clicking sound)	Controller active
LED 2 on (red)	Left limit reached
LED 3 on (red)	Right limit reached
LED 4 on, LED 5 off	Error in sensor circuit

Table 1. LED Indicators (Continued)

LED 4 off, LED 5 on	Error in controller or motor circuit
LED 4 on, LED 5 on	Error in controller
LED 4 off, LED 5 off, and LED 1 on (with no sound from motor)	Supply contactor fault or voltage on emergency brake coil (the controller must remain off for a minimum of 2 seconds before a new startup to avoid an error condition)

Check Steering System for Correct Operation, EPS III

The ECM check includes checks for the command potentiometer and the feedback potentiometer.

1. Open the motor compartment door. Move the key switch to the **ON** position and push the foot switch. Make sure the battery has a corrected specific gravity of at least 1.250.
2. Check the system for correct operation, move the steering handle or steering wheel from a full left turn position to a full right turn position. The master drive unit should move 85 to 95 degrees in each direction from straight travel.
3. If the master drive unit moves less than 90 degrees (± 5 degrees) in either direction, the steering is incorrectly adjusted or may have a mechanical problem. Refer to Adjustments.
4. Check that the master drive unit moves through the full range of rotation in 5 seconds or less. The lift truck must be on smooth concrete with a fully charged battery and no load.
5. If the master drive unit requires greater than 5 seconds to move through the full range of rotation, check for a mechanical problem or defective ECM.

Check Slow Travel Speed, EPS III

NOTE: The slow travel speed is checked during the adjustment procedure. Refer to Adjustments.

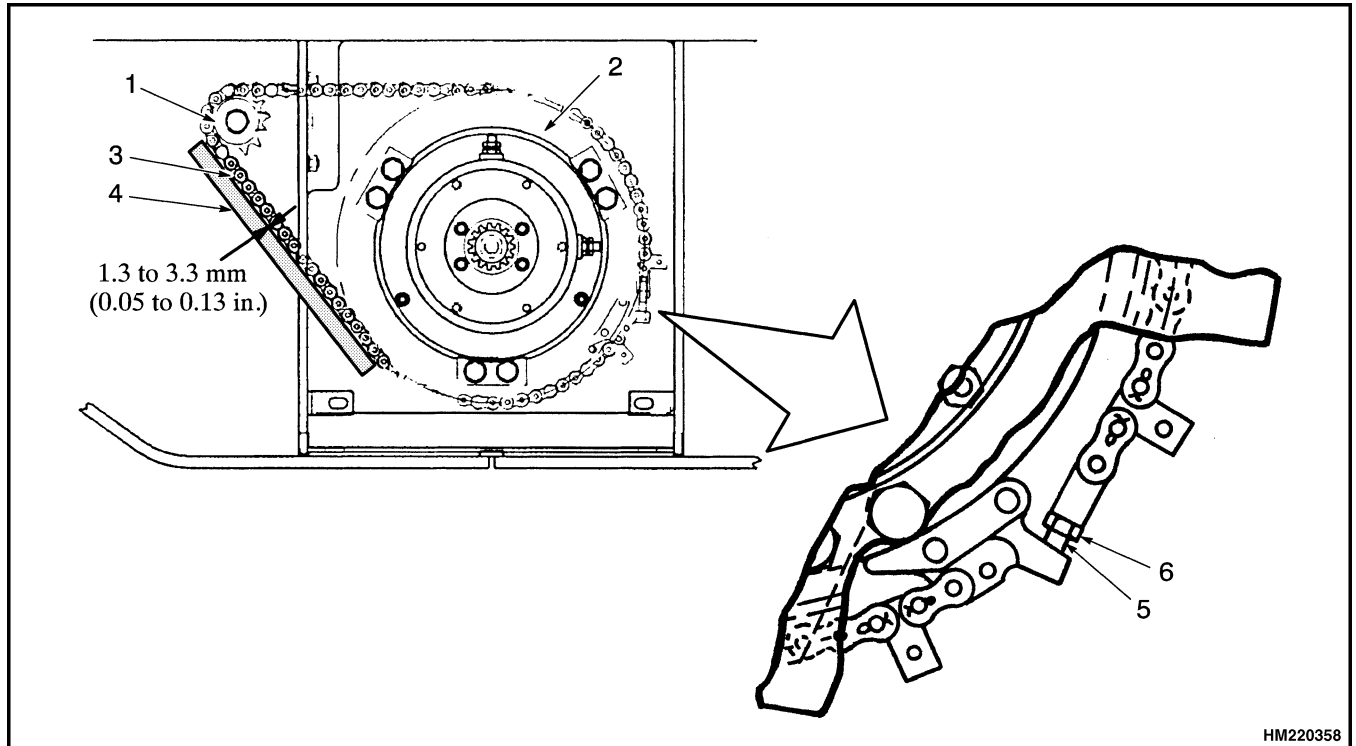

1. MOTOR SPROCKET
2. MDU
3. STEERING CHAIN

4. STRAIGHT EDGE
5. ADJUSTING BOLT
6. ADJUSTING NUT

Figure 9. Steer Chain Adjustment

Repairs

RTC STEERING SYSTEM, EPS III

Command Potentiometer Replacement, EPS III



WARNING

The MDU will automatically center when key is ON. Keep hands, arms, and other appendages and tools clear.

1. Disconnect the battery connector.
2. Remove the screw that fastens the steering handle to the shaft of the steering mechanism. Remove the steering handle.
3. Remove the screws at the top of the instrument panel. Tilt the instrument panel to the open position for access.
4. Remove the capscrews that fasten the steering mechanism bracket to the back of the instrument panel.
5. Remove the setscrew that fastens the shaft of the command potentiometer to the steering shaft. Remove the capscrew and nut that fasten the bracket for the command potentiometer. Remove the bracket and potentiometer. Remove the potentiometer from the bracket. Label the potentiometer wires for correct connections during installation.
6. Install the new command potentiometer as required. Connect the wires of the command potentiometer.
7. Install the steering mechanism bracket to the back of the instrument panel.
8. Connect all wires disconnected during removal.

Hydraulic main cylinders are installed vertically on the weldments. See Figure 2. The two-stage masts have two single-stage main cylinders that raise the inner mast weldment and the operator platform.

The three-stage mast also has two single-stage main cylinders. The two main cylinders raise the intermediate and inner mast weldments and operator platform at the same speed.

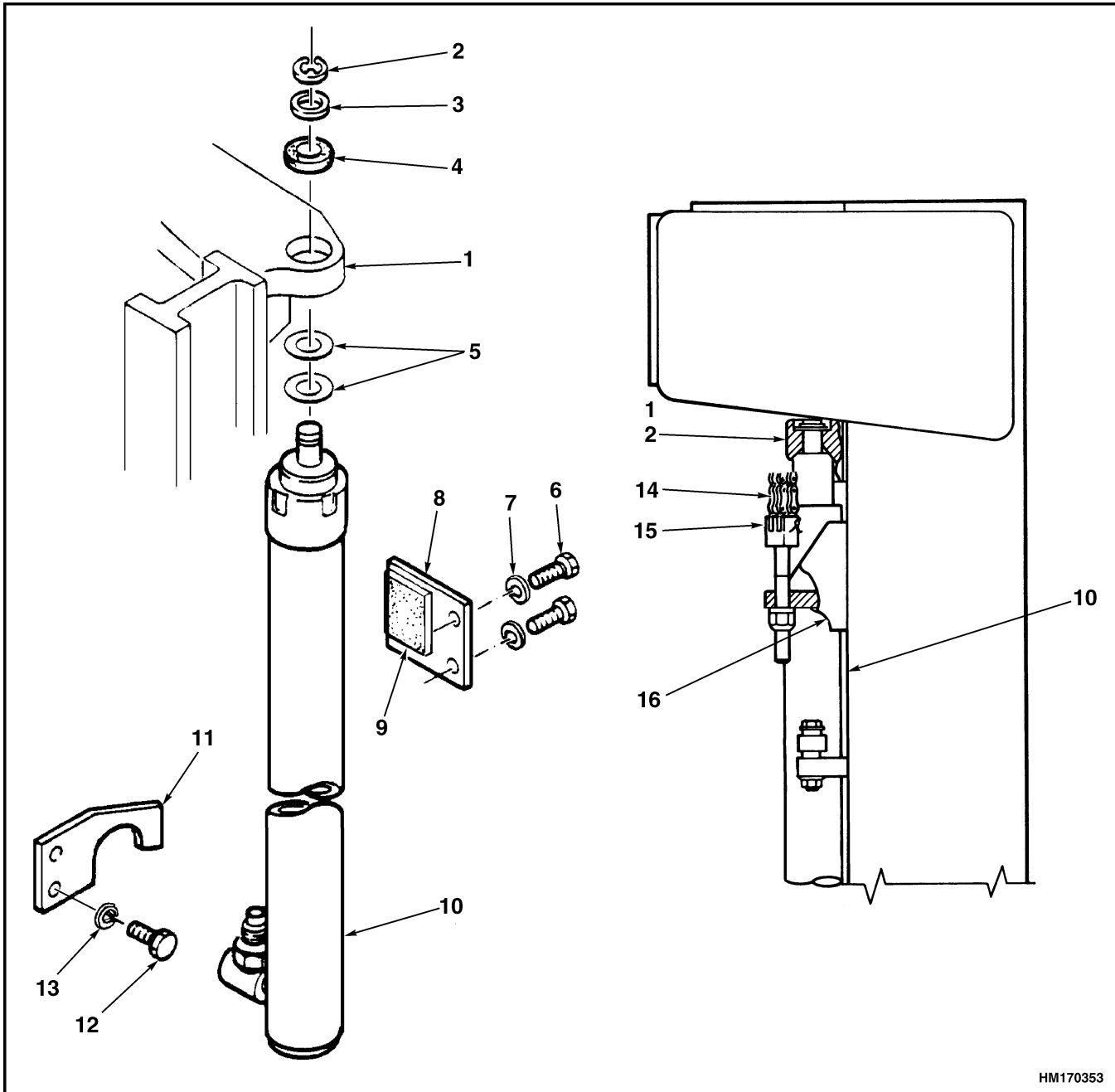

- | | |
|------------------------|------------------------|
| 1. LIFT CYLINDER MOUNT | 9. CUSHION |
| 2. RETAINING RING | 10. MAIN LIFT CYLINDER |
| 3. WASHER - BACK | 11. LOCK PLATE |
| 4. RUBBER BUSHING | 12. SCREW |
| 5. SHIMS | 13. LOCKWASHER |
| 6. SCREW | 14. LIFT CHAIN |
| 7. LOCKWASHER | 15. CHAIN ANCHOR |
| 8. CYLINDER RETAINER | |

HM170353

TABLE OF CONTENTS

General	1
Forks	1
Replace	1
Operator Platform	2
Remove	2
Install	5
Two-Stage Upright	5
Remove	5
Disassemble	6
Clean and Inspect	8
Lift Cylinders	10
Assemble	10
Install	10
Three-Stage Upright	11
Remove	11
Disassemble	11
Clean and Inspect	13
Lift Cylinders	13
Assemble	13
Install	15
Load Wheels Replacement	16
Lift System Leak Check	16
Lift Chain Adjustment	16
Upright Adjustments	18
Operator Platform Adjustment	19
Troubleshooting	19

This section is for the following models:

N40-50EA, N40-45ER [C138];
R30E/EA, R30EA-FS [D118];
R30XM/XMA/XMF [F118];
R30XMS2 [D174];
R30XM2, R30XMA2, R30XMF2 [G118]

 **WARNING**

Do NOT weld on uprights. Get information from your Hyster lift truck dealer before welding on uprights.

6. Inspect the sliding and rolling surfaces. Inspect the welds around the stub shafts.

LIFT CYLINDERS

NOTE: The lift cylinders are removed during disassembly of the upright. To repair the cylinders, see the section **Lift Cylinders** 4000 SRM 135 for the correct service procedures.

ASSEMBLE

NOTE: The shims for the load rollers keep the channels of the upright weldments parallel and give correct clearance. During assembly, the arrangement of the shims will be the same or approximately the same as they were before disassembly. Check the clearance and adjust for wear or changes from the repairs. The strip bearings at the top of the outer upright weldment and the bottom of the inner upright weldment are also adjusted using shims. See the Checks And Adjustments in this section for the instructions to make the necessary adjustments.

1. Assemble the load rollers, sheaves, and strip bearings on the upright weldments and operator platform as necessary. Make sure to keep the same shim arrangement noted during disassembly. Apply a thin layer of multipurpose grease to the strip bearings and the bearing and roller surfaces of the channels.
2. Make sure the cylinders are assembled and install a sling near the center of the cylinder as during removal. Use a crane to move the cylinder into position in the outer upright weldment. Install the snap ring on the bottom of the cylinder. Install the capscrew, washer, and spacer to fasten the cylinder shell to the channel. Repeat the procedure to install the other cylinder.
3. Use the crane to move the inner upright weldment into position over the outer upright weldment. Fasten the slings to the centers of the channels to balance the weldment as during removal. Make sure the inner upright weldment is at approximately a 30° angle with the bottom load rollers in the notch near the top load rollers of the outer upright channels. Slowly lower the

inner upright weldment and insert it into the outer upright weldment.

4. Check the clearance of the load rollers and the strip bearings. Make the necessary adjustments as described in Upright Adjustments.
5. With the inner upright weldment approximately 152 to 305 mm (6 to 12 in.) out of the outer upright weldment, install the chain and hose sheaves. Move the inner upright weldment into the outer upright weldment so the tops of the cylinder rods are through the holes in the inner upright channels. Install the washers and snap rings to fasten the cylinder rods to the channels.

INSTALL

NOTE: To make alignment of the upright, spacers, and lift truck frame during installation, make two to four alignment studs. Cut the heads off extra mount capscrews and grind the end into a dull point.

1. Install the alignment studs in the bottom mount holes. Install the bottom spacers on the studs.
2. Use chains to fasten the upright weldments together so they cannot move. Connect a crane to the top of the upright assembly. Make sure the crane and chains have the capacity to lift the upright assembly. Make sure the chains will not damage the sheaves or other parts of the upright assembly.

 **WARNING**

Upright assemblies are heavy and can cause an injury when moving. NEVER put any part of your body between the upright and a solid object when the upright is being moved.

3. Raise the upright assembly to a vertical position. Install the cross tube (horizontal) at the battery side of the bottom of the upright. Carefully move the upright assembly into approximately the correct position near the alignment studs. Install the electrical cables and hydraulic lines through the upright and frame holes as the upright moves into the correct position. The upright and spacers are in correct alignment when the studs can be removed without using a tool. Hold the top spacers and install the mount capscrews, washers, and spacers. The longer capscrews are installed at the bottom of the upright. Replace all the alignment studs with capscrews. Tighten all eight capscrews to 380 N•m (280 lbf ft).

PROBLEM	POSSIBLE CAUSE	PROCEDURE OR ACTION
Rough movement of the upright assembly. (Cont.)	Upright assembly damaged or not in alignment.	Inspect, repair, or align upright assembly.

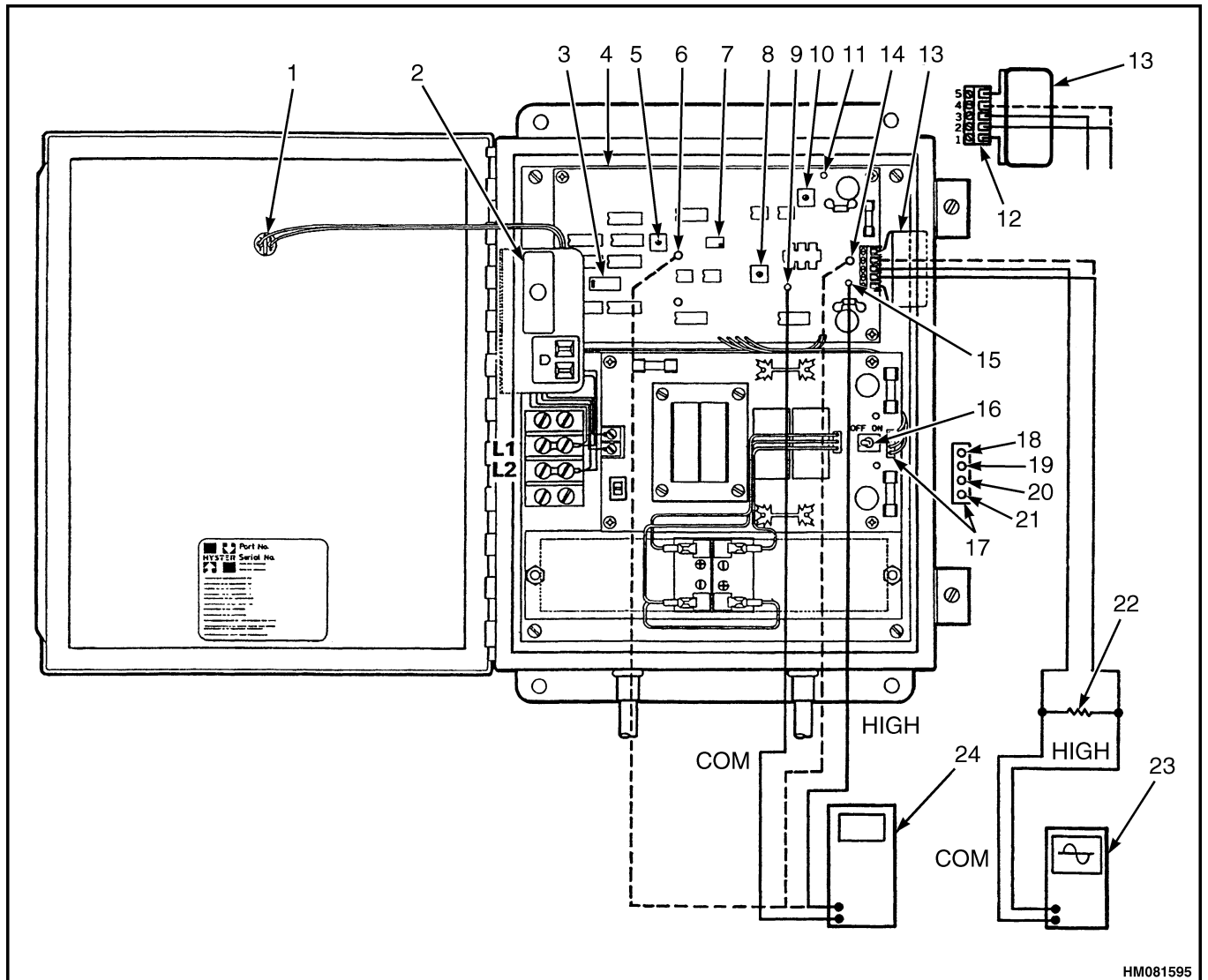

HM081595

- | | |
|-----------------------------------|-------------------------------------|
| 1. FAULT LAMP (LED 2 LOGIC BOARD) | 13. CAPACITOR C31 |
| 2. INTERLOCK BUTTON | 14. TP3 |
| 3. FREQUENCY SELECT SWITCHES | 15. TP4 |
| 4. LOGIC BOARD | 16. TOGGLE SWITCH S1 |
| 5. R89 CALIBRATION ADJUST | 17. CP2 |
| 6. TP2 | 18. + DC (PIN 1) |
| 7. R47 CURRENT ADJUST | 19. COMMON (PIN 2) |
| 8. R78 OUTPUT AMPLITUDE ADJUST | 20. - DC (PIN 3) |
| 9. TP1 | 21. AC (PIN 4) |
| 10. R62 CURRENT WINDOW ADJUST | 22. 15 OHM, 10 WATT RESISTOR (LOAD) |
| 11. LED 1 | 23. OSCILLOSCOPE |
| 12. TERMINAL STRIP TS1 | 24. DIGITAL VOLTMETER |

Figure 5. Wire Driver Adjustments (Late Model)

CLICK HERE TO **DOWNLOAD** THE COMPLETE MANUAL

- Thank you very much for reading the preview of the manual.
- You can download the complete manual from: www.heydownloads.com by clicking the link below



- Please note: If there is no response to CLICKING the link, please download this PDF first and then click on it.

CLICK HERE TO **DOWNLOAD** THE COMPLETE MANUAL