

1998-2004



**HONDA**

**SERVICE MANUAL**

**TRX450S/FM**

**FOURTRAX FOREMAN<sup>®</sup> S/FM**

**TRX450ES/FE**

**FOURTRAX FOREMAN<sup>®</sup> ES/FE**

CLICK HERE TO **DOWNLOAD** THE COMPLETE MANUAL

- Thank you very much for reading the preview of the manual.
- You can download the complete manual from: [www.heydownloads.com](http://www.heydownloads.com) by clicking the link below



- Please note: If there is no response to CLICKING the link, please download this PDF first and then click on it.

CLICK HERE TO **DOWNLOAD** THE COMPLETE MANUAL

## GENERAL INFORMATION

Unit: mm (in)

CYLINDER HEAD/VALVES/CAMSHAFT			STANDARDS	SERVICE LIMIT
ITEM				
Cylinder compression	Decompressor effected		539 – 834 kPa (5.5 – 8.5 kgf/cm <sup>2</sup> , 78 – 121 psi) at 450 rpm	—
	Decompressor not effected		1,226 – 1,442 kPa (12.5 – 14.5 kgf/cm <sup>2</sup> , 178 – 206 psi) at 450 rpm	—
Valve, Valve guide	Valve clearance	IN	0.15 (0.006)	—
		EX	0.15 (0.006)	—
	Valve stem O.D.	IN	5.475 – 5.490 (0.2156 – 0.2161)	5.45 (0.215)
		EX	5.455 – 5.470 (0.2148 – 0.2154)	5.43 (0.214)
	Valve guide I.D.	IN	5.500 – 5.512 (0.2165 – 0.2170)	5.525 (0.2175)
		EX	5.500 – 5.512 (0.2165 – 0.2170)	5.525 (0.2175)
	Stem to guide clearance	IN	0.010 – 0.037 (0.0004 – 0.0015)	0.12 (0.005)
		EX	0.030 – 0.057 (0.0012 – 0.0022)	0.14 (0.006)
Valve seat width		1.2 (0.005)	1.5 (0.06)	
Valve spring free length	Inner		36.85 (1.451)	35.84 (1.411)
	Outer		41.67 (1.641)	40.42 (1.591)
Rocker arm/ shaft	Rocker arm I.D.		12.000 – 12.018 (0.4724 – 0.4731)	12.05 (0.474)
	Rocker arm shaft O.D.		11.964 – 11.984 (0.4710 – 0.4718)	11.92 (0.469)
	Rocker arm to shaft clearance		0.016 – 0.054 (0.0006 – 0.002)	0.08 (0.003)
Camshaft and cam follower	Cam lobe height	IN	36.4291 – 36.4291 (1.43421 – 1.44051)	36.25 (1.427)
		EX	36.2670 – 36.4270 (1.42783 – 1.43131)	36.10 (1.421)
	Cam follower O.D.	IN/EX	22.467 – 22.482 (0.8845 – 0.8851)	22.46 (0.884)
	Cam follower bore O.D.	IN/EX	22.510 – 22.526 (0.8862 – 0.8868)	22.54 (0.887)
Cam follower to bore clearance		0.028 – 0.059 (0.0011 – 0.0023)	0.07 (0.003)	

Unit: mm (in)

CYLINDER/PISTON			STANDARDS	SERVICE LIMIT
ITEM				
Cylinder	I.D.		90.00 – 90.01 (3.543 – 3.544)	90.10 (3.547)
	Taper		—	0.10 (0.004)
	Out of round		—	0.10 (0.004)
	Warpage		—	0.10 (0.004)
Piston, piston rings, piston pin	Piston mark direction		"IN" mark facing toward the intake side	—
	Piston O.D.		89.945 – 89.965 (3.5411 – 3.5419)	89.90 (3.539)
	Piston O.D. measurement point		10 mm (0.4 in) from bottom of skirt	—
	Piston pin bore I.D.		19.002 – 19.008 (0.7481 – 0.7483)	19.08 (0.751)
	Piston pin O.D.		18.994 – 19.000 (0.7478 – 0.7480)	18.96 (0.746)
	Piston-to piston pin clearance		0.002 – 0.014 (0.0001 – 0.0006)	0.12 (0.039)
	Piston ring-to-ring groove clearance	Top	0.030 – 0.060 (0.0011 – 0.0024)	0.09 (0.004)
		Second	0.015 – 0.45 (0.0006 – 0.0018)	0.09 (0.004)
	Piston ring end gap	Top	0.015 – 0.30 (0.006 – 0.012)	0.5 (0.02)
		Second	0.300 – 0.450 (0.012 – 0.018)	0.6 (0.02)
Oil (side rail)		0.20 – 0.70 (0.008 – 0.028)	—	
Cylinder-to-piston clearance		0.035 – 0.056 (0.0014 – 0.0022)	0.10 (0.004)	
Connecting rod small end I.D.		19.020 – 19.041 (0.7488 – 0.7496)	19.07 (0.7508)	
Connecting rod-to piston pin clearance		0.020 – 0.047 (0.0008 – 0.0019)	0.10 (0.004)	

## GENERAL INFORMATION

DESCRIPTION	TOOL NUMBER	REMARKS	REF. SEC.
Bearing remover set	07936 - 3710001	NOTE 3	11
- Remover handle	07936 - 3710100		11
- Bearing remover, 20 mm	07936 - 3710600		11
- Remover weight	07741 - 0010201	NOTE 4: 07936 - 371020A or 07936 - 3710200	11
Remover handle	07936 - 3710100		8, 11, 13
Bearing remover, 17 mm	07936 - 3710300		8, 11, 13
Clutch puller	07933 - HA80000	NOTE 4: 07933 - HB3000A	8
Attachment	07945 - 3330300	NOTE 4: 07746 - 0010400	12
Attachment, 28 × 30 mm	07946 - 1870100		12
Driver handle attachment	07949 - 3710001		12
Oil seal driver (After '01)	07965 - KE80100		15
Driver attachment	07965 - KE80200	NOTE 4: 07947 - KA50100	15 ('98 - '01), 16
Oil seal driver	07965 - MC70100		14
Assembly collar	07965 - VM00100		11
Assembly shaft	07965 - VM00200	NOTE 4: 07931 - ME4010B and 07931 - HB3020A (U.S.A. only)	11
Threaded adapter	07965 - VM00300	NOTE 4: 07931 - KF00200 (U.S.A. only)	11
Valve guide reamer, 5.5 mm	07984 - 2000001	NOTE 4: 07984 - 200000D (U.S.A. only)	7
Clutch holder	07GMB - HA70101	NOTE 4: 07GMB-HA7010A or 07GMB-HA7011A and 07GMB-HA7012A	8
Inspection adaptor	07GMJ - ML80100		20
Peak voltage adapter	07HGJ - 0020100	NOTE 4: Peak voltage tester (U.S.A. only)	18
Pinion puller set	07HMC - MM80101	NOTE 3	15 ('98 - '01), 16
- Shaft puller	07931 - ME40000	NOTE 4: 07931 - ME4010B and 07931 - HB3020A (U.S.A. only)	15 ('98 - '01), 16
- Pinion puller base	07HMC - MM80110	NOTE 4: 07HMC - MM8011A (U.S.A. only)	15, 16
Adjustable bearing puller (After '01)	07JAC - PH80101		15
Remover shaft (After '01)	07JAC - PH80200		15
Oil seal driver attachment	07JAD - PH80101		10, 12
Clutch center holder	07JMB - MN50300	NOTE 4: 07HGB - 001010B and 07HGB - 001020B (U.S.A. only)	8
Differential inspection tool	07KMK - HC50101	NOTE 4: 07KMK - HC5010A (U.S.A. only)	15
Ball joint remover, 28 mm	07MAC - SL00200		12, 14
Pilot, 32 mm	07MAD - PR90200		11, 16
Ball joint installer base	07HAF - SF10120		12
Recoil pulley holder	07SMB - HM70100		10
Pinion holder ('98 - '01)	07SMB - HM70200		15, 16
Ball joint remover/installer	07WMF - HN00100	NOTE 1	12
Universal bead breaker	GN-AH-958-BB1		12, 13

TRX450FM (After '01):

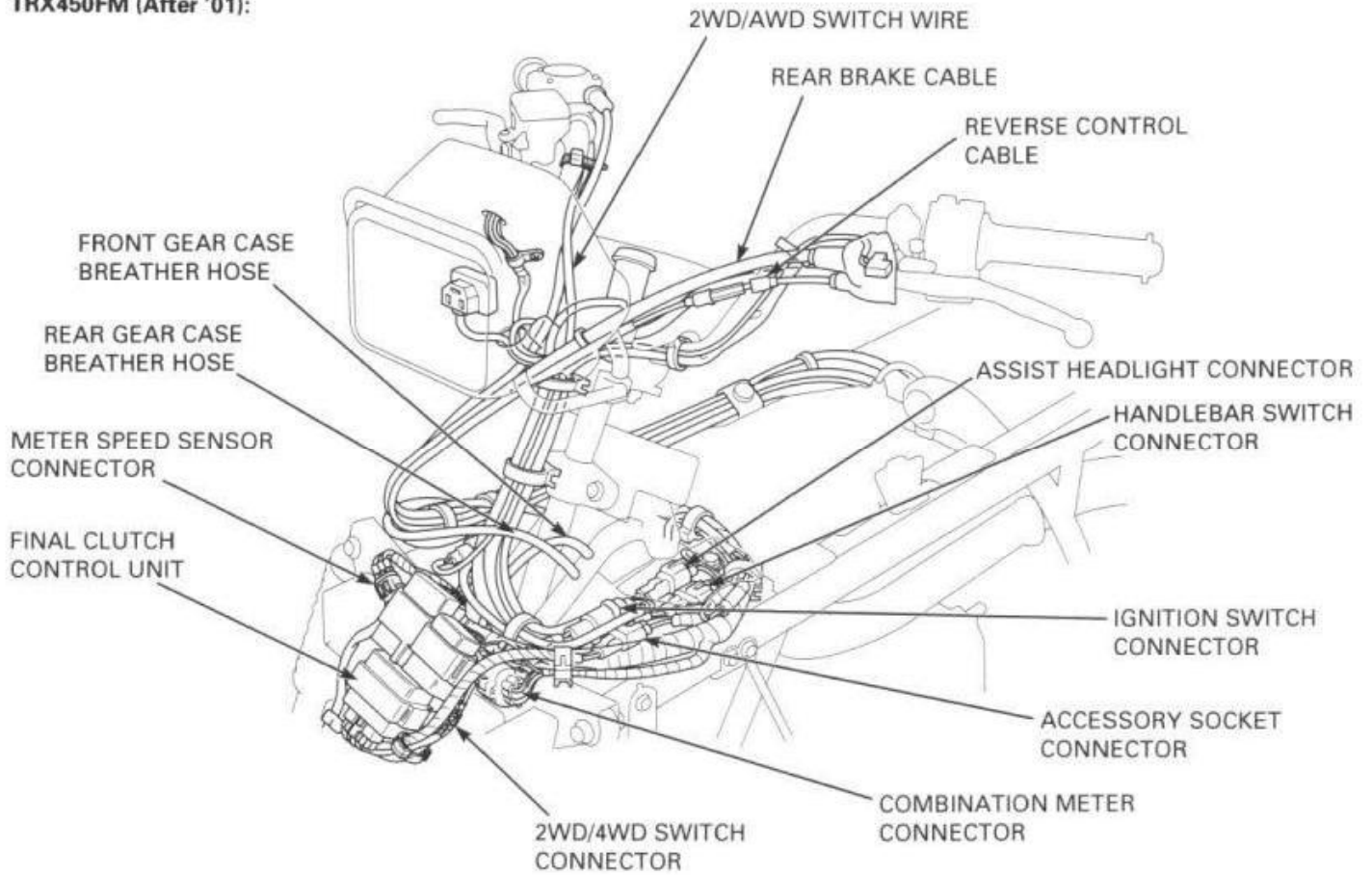

TRX450FE (After '01):

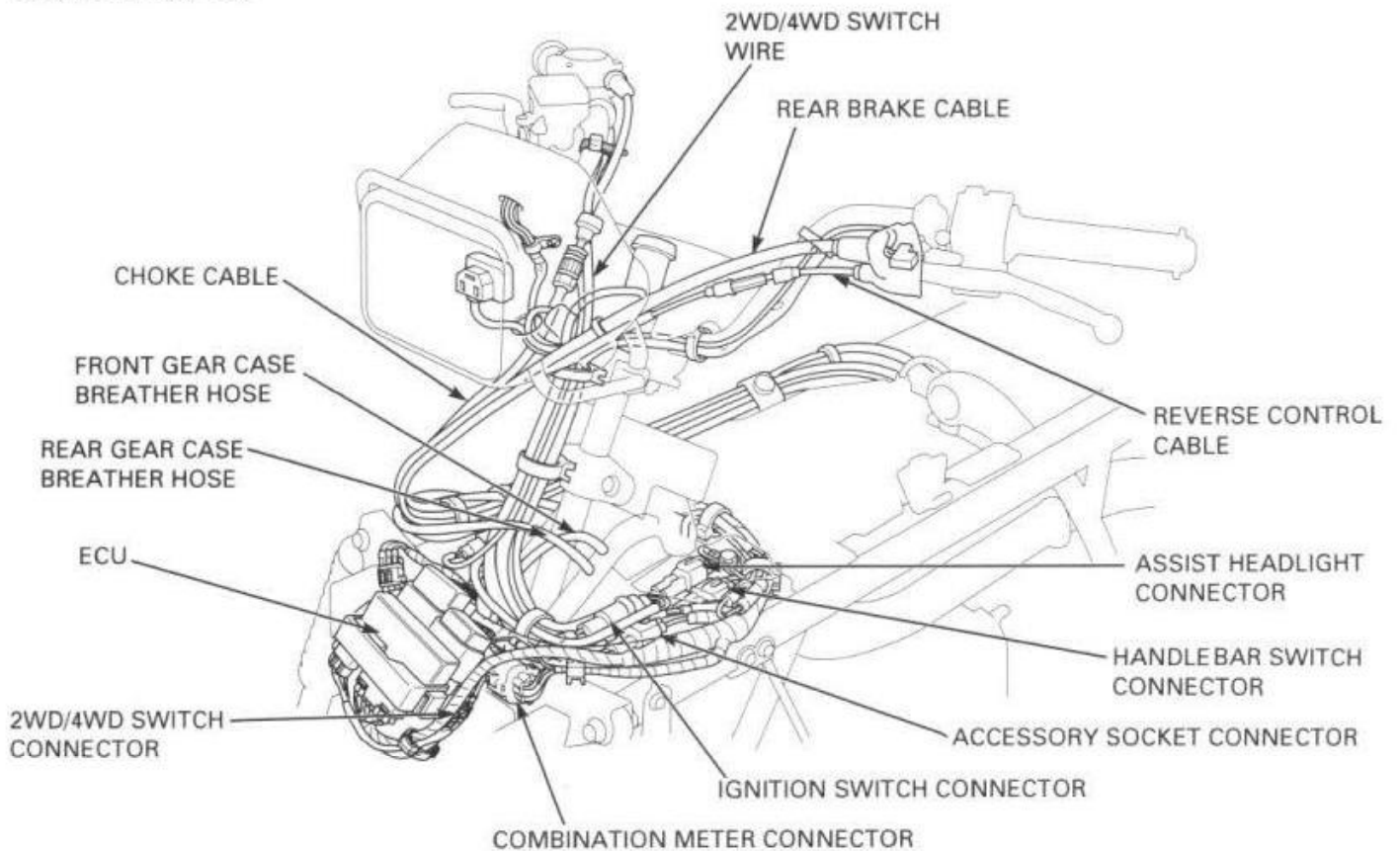

TRX450FM (After '01):

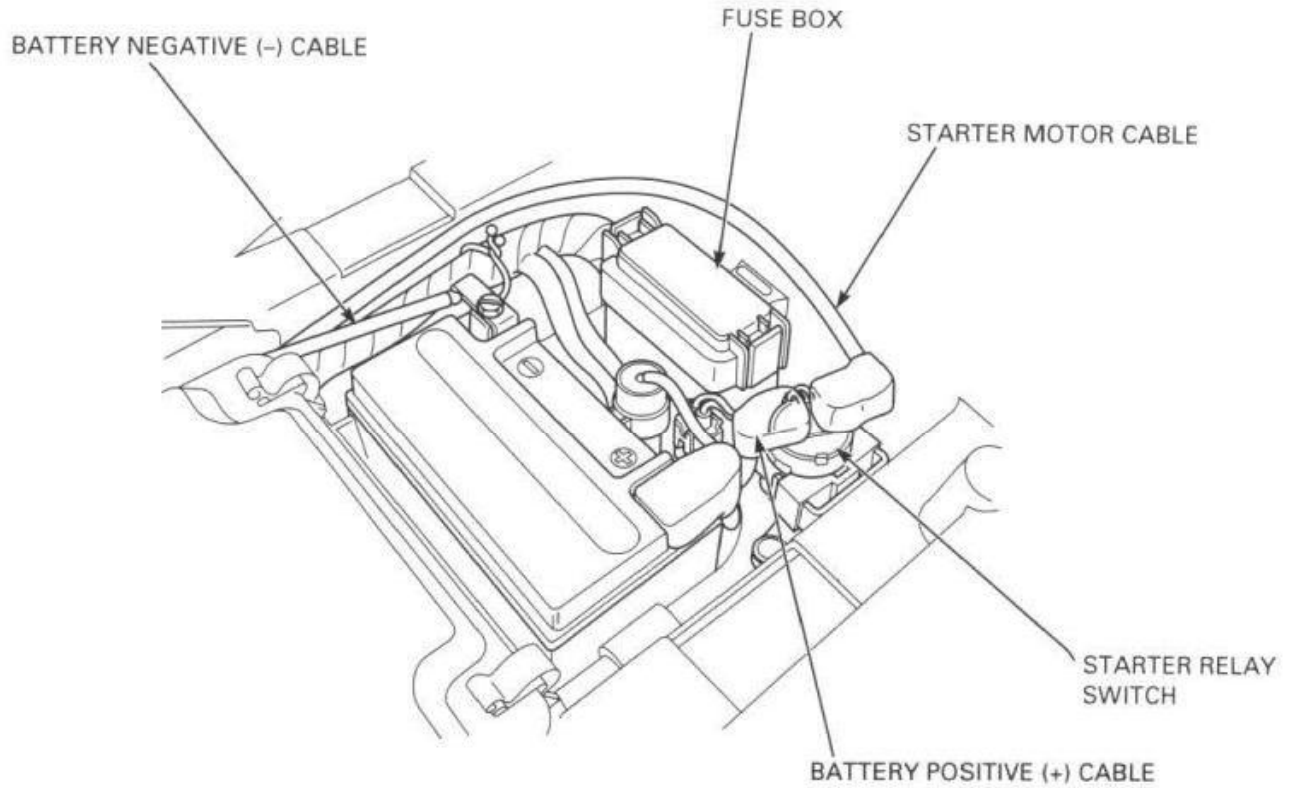

TRX450FE (After '01):

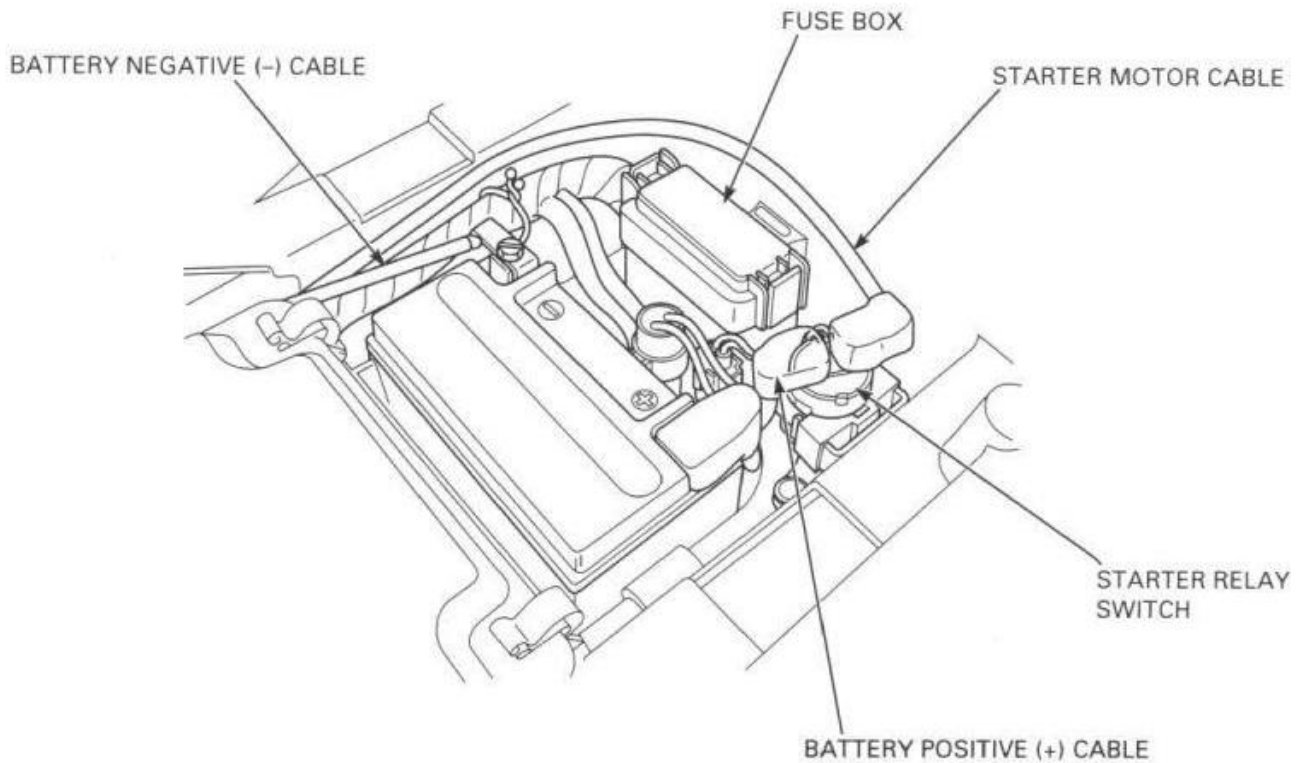

Disconnect the headlight connector.

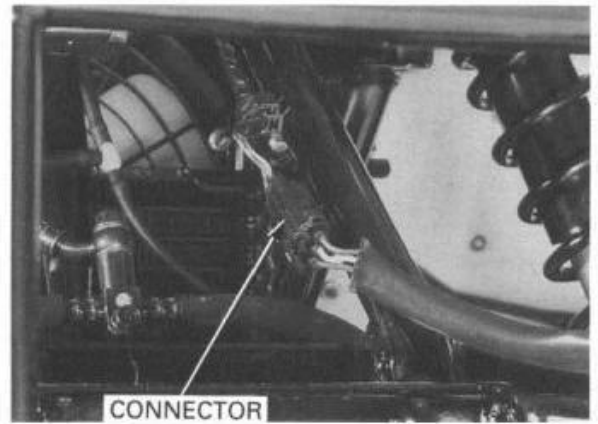

Remove the upper mounting bolts on each side.



Remove the middle mounting bolts on each side.

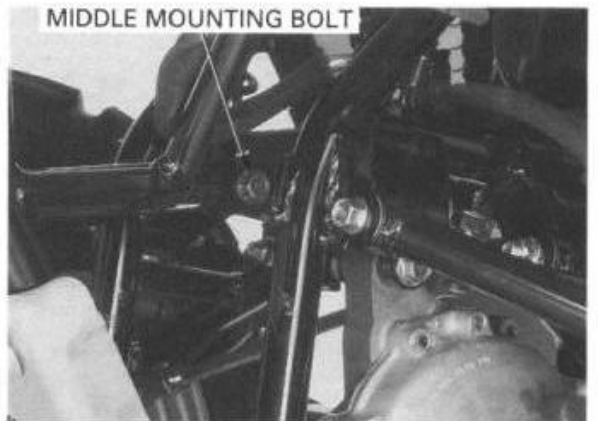

Remove the lower mounting bolts on each side.

Remove the front fender, carry pipe and front carrier as an assembly.

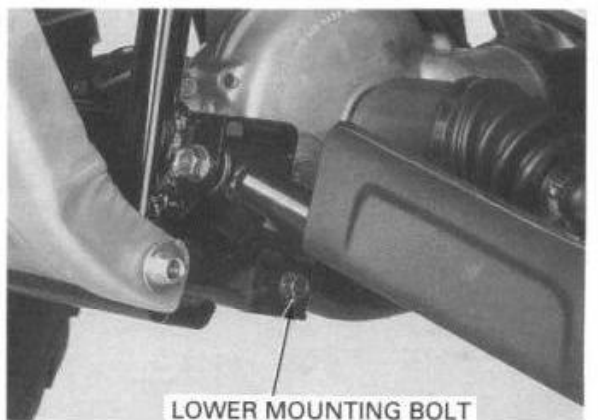

Install the new muffler gasket and flange bolts loosely.

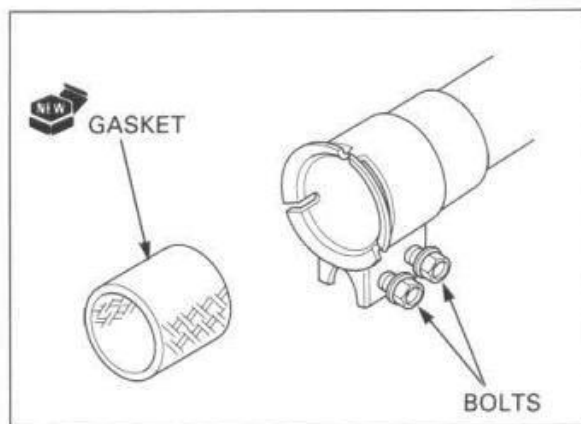

Install the two bolts/washers loosely.

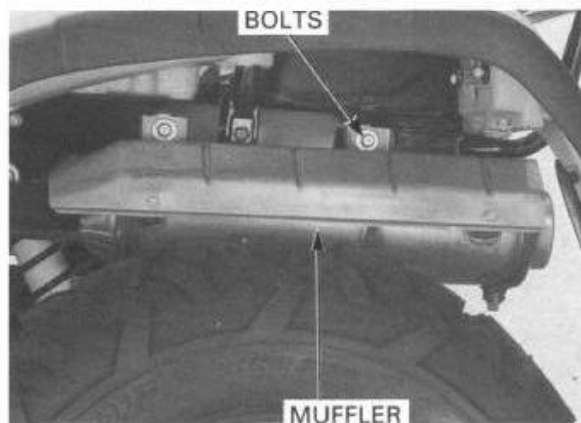

Tighten the exhaust pipe flange nuts securely.

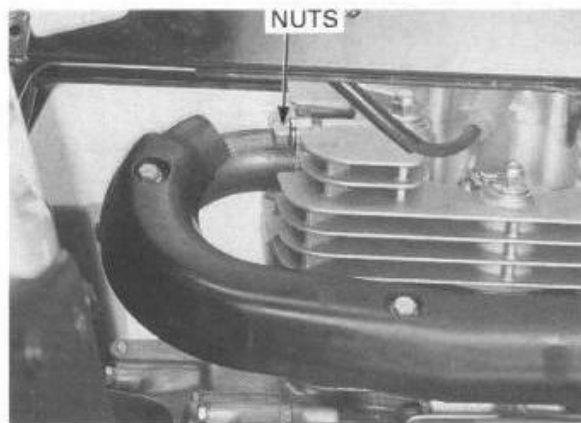

Tighten the muffler band bolt to the specified torque.

**TORQUE: 23 N·m (2.3 kgf·m , 17 lbf·ft)**

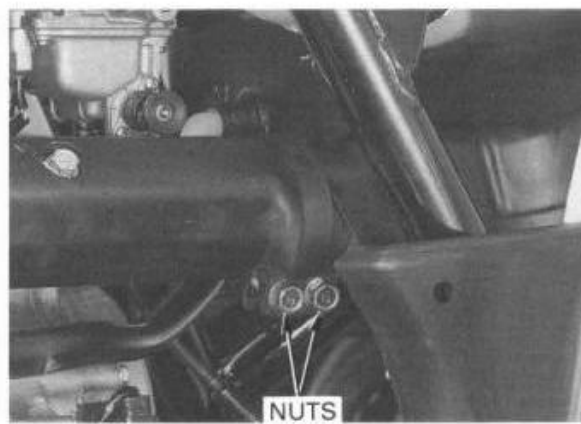

Turn the crankshaft clockwise using the recoil starter knob, and align the "T" mark on the flywheel with the index mark on the rear crankcase cover. Make sure the piston is at TDC on the compression stroke.

If not, rotate the crankshaft 360° (1 full turn) and align the "T" mark with the index mark.

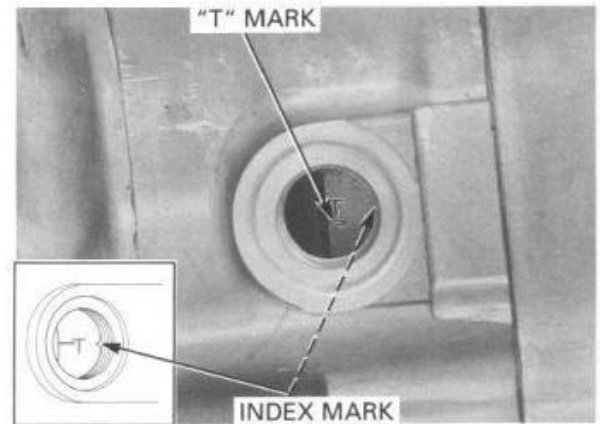

Inspect the intake and exhaust valve clearances by inserting a feeler gauge between the adjusting screw and valve stem.

**VALVE CLEARANCE: IN/EX: 0.15 mm (0.006 in)**

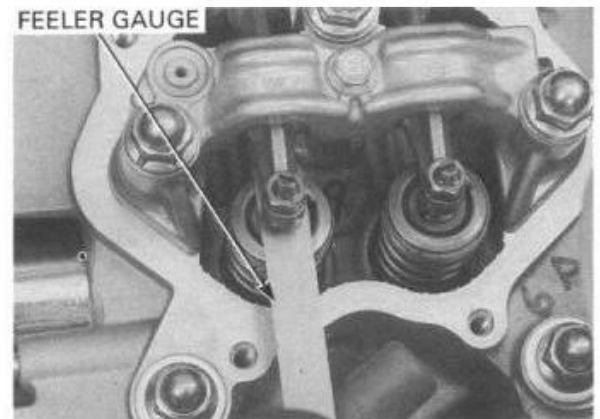

Adjust if necessary by loosening the lock nut and turning the adjusting screw until there is a slight drag on the feeler gauge.

Hold the adjusting screw and tighten the lock nut.

**TORQUE: 17 N·m (1.7 kgf·m , 12 lbf·ft)**

Recheck the valve clearance.

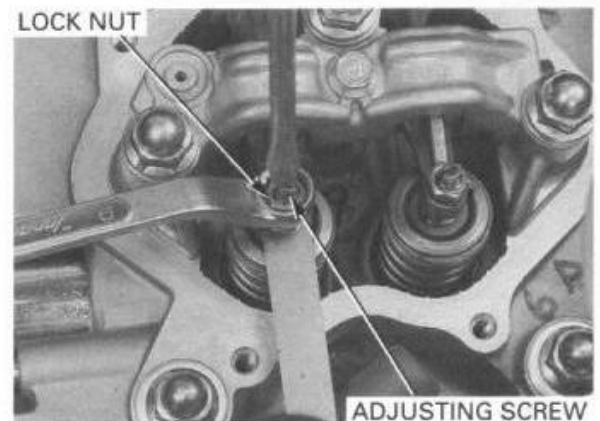

Inspect the condition of the cylinder head cover gasket and O-ring, replace them if necessary. Install the cylinder head cover and tighten the bolts.

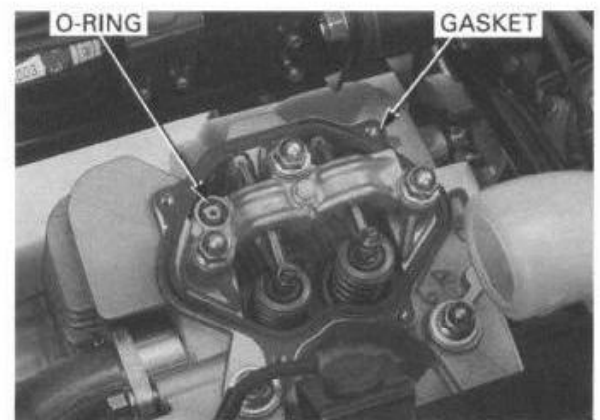

## SKID PLATES/ENGINE GUARD

The skid plates and engine guard protect the rear final gear case and engine from rocks.

Check the skid plates and engine guard for cracks, damage or looseness at intervals shown in the Maintenance Schedule (page 3-3).

Replace the skid plates and engine guard if they are cracked or damaged.

If the plates and engine guard bolts are loose, tighten them.

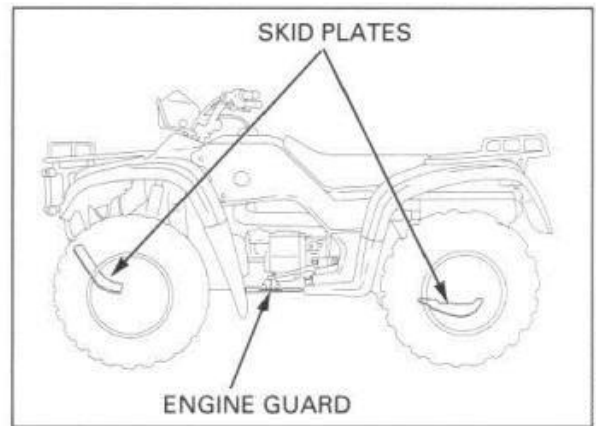

## CLUTCH SYSTEM

### **⚠ WARNING**

*If the engine must be running to do some work, make sure the area is well ventilated. Never run the engine in an enclosed area. The exhaust contains poisonous carbon monoxide gas that may cause loss of consciousness and may lead to death. Run the engine in an open area or with an exhaust evacuation system in enclosed area.*

Loosen the clutch adjusting screw lock nut.

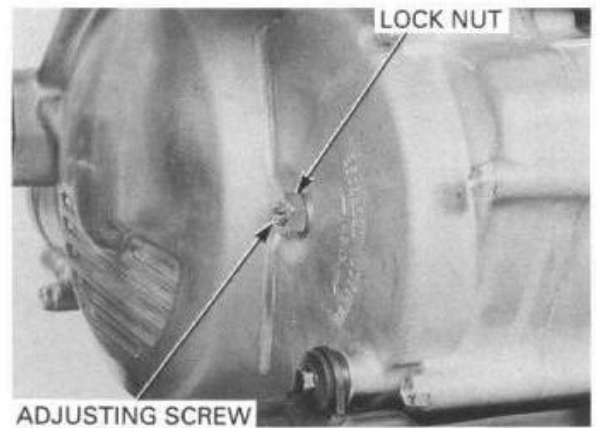

Slowly turn the adjusting screw counterclockwise until resistance is felt. Then turn the adjusting screw clockwise 1/4 turn, and tighten the lock nut to the specified torque.

**TORQUE: 22 N·m (2.2 kgf·m, 16 lbf·ft)**

After adjustment, start the engine and check for proper clutch operation.

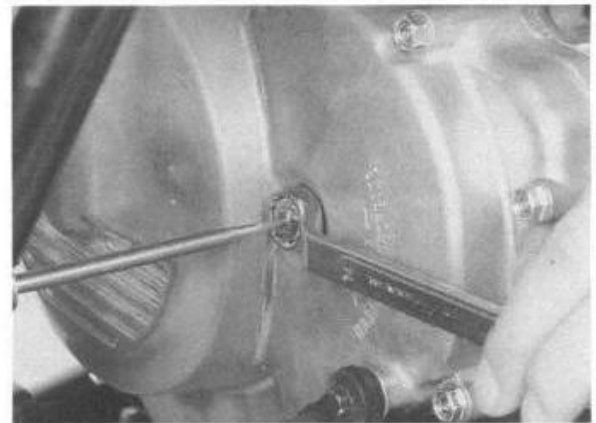

Remove the bracket bolts and cooling fan motor/shroud assembly from the left.

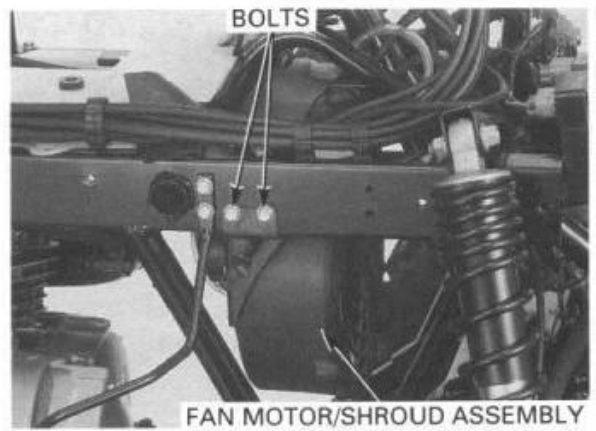

### COOLING FAN MOTOR/SHROUD DISASSEMBLY

Remove the screws and cooling fan cover.

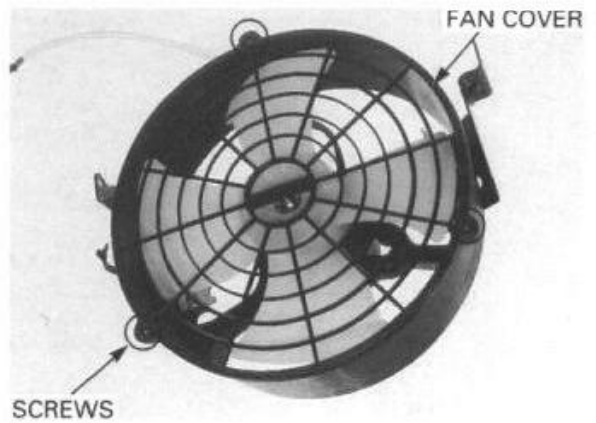

Remove the cooling fan nut and cooling fan.

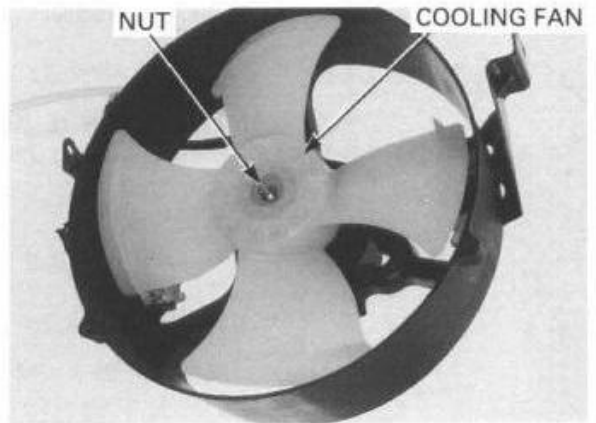

Remove the collar and cap.

Remove the screws, fan motor, collars and grommets.

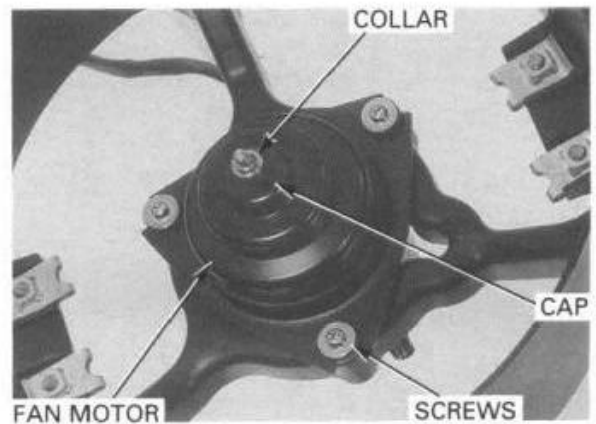

# 5. FUEL SYSTEM

SERVICE INFORMATION	5-1	CARBURETOR INSTALLATION	5-16
TROUBLESHOOTING	5-3	PILOT SCREW ADJUSTMENT	5-17
AIR CLEANER HOUSING	5-4	HIGH ALTITUDE ADJUSTMENT	5-19
CARBURETOR REMOVAL	5-5	FUEL TANK REMOVAL	5-20
CARBURETOR DISASSEMBLY	5-6	FUEL STRAINER SCREEN	5-22
CARBURETOR ASSEMBLY	5-11	FUEL TANK INSTALLATION	5-22

## SERVICE INFORMATION

### GENERAL

**▲ WARNING**

- Gasoline is extremely flammable and is explosive under certain conditions. **KEEP OUT OF REACH OF CHILDREN.**
- If the engine must be running to do some work, make sure the area is well ventilated. Never run the engine in an enclosed area. The exhaust contains poisonous carbon monoxide gas that may cause loss of consciousness and may lead to death. Run the engine in an open area or with an exhaust evacuation system in enclosed area.
- Bending or twisting the control cables will impair smooth operation and could cause the cable to stick or bind, resulting in loss of vehicle control.

- Work in a well ventilated area. Smoking or allowing flames or sparks in the work area or where gasoline is stored can cause a fire or explosion.

**CAUTION:**

*Be sure to remove the diaphragms before cleaning air and fuel passages with compressed air. The diaphragms might be damaged.*

**NOTE:**

If the vehicle is to be stored for more than one month, drain the float chamber. Fuel left in the float chamber may cause clogged jets resulting in hard starting or poor driveability.

- Before disassembling the carburetor, place an approved gasoline container under the carburetor drain screw, loosen the screw and drain the carburetor.
- When disassembling the fuel system parts, note the locations of the O-rings. Replace them with new ones on reassembly.
- After removing the carburetor, wrap the intake port of the engine with a shop towel or cover it with a piece of tape to prevent any foreign material from dropping into the engine. Be sure to remove the cover when reinstalling the carburetor.

# CARBURETOR ASSEMBLY

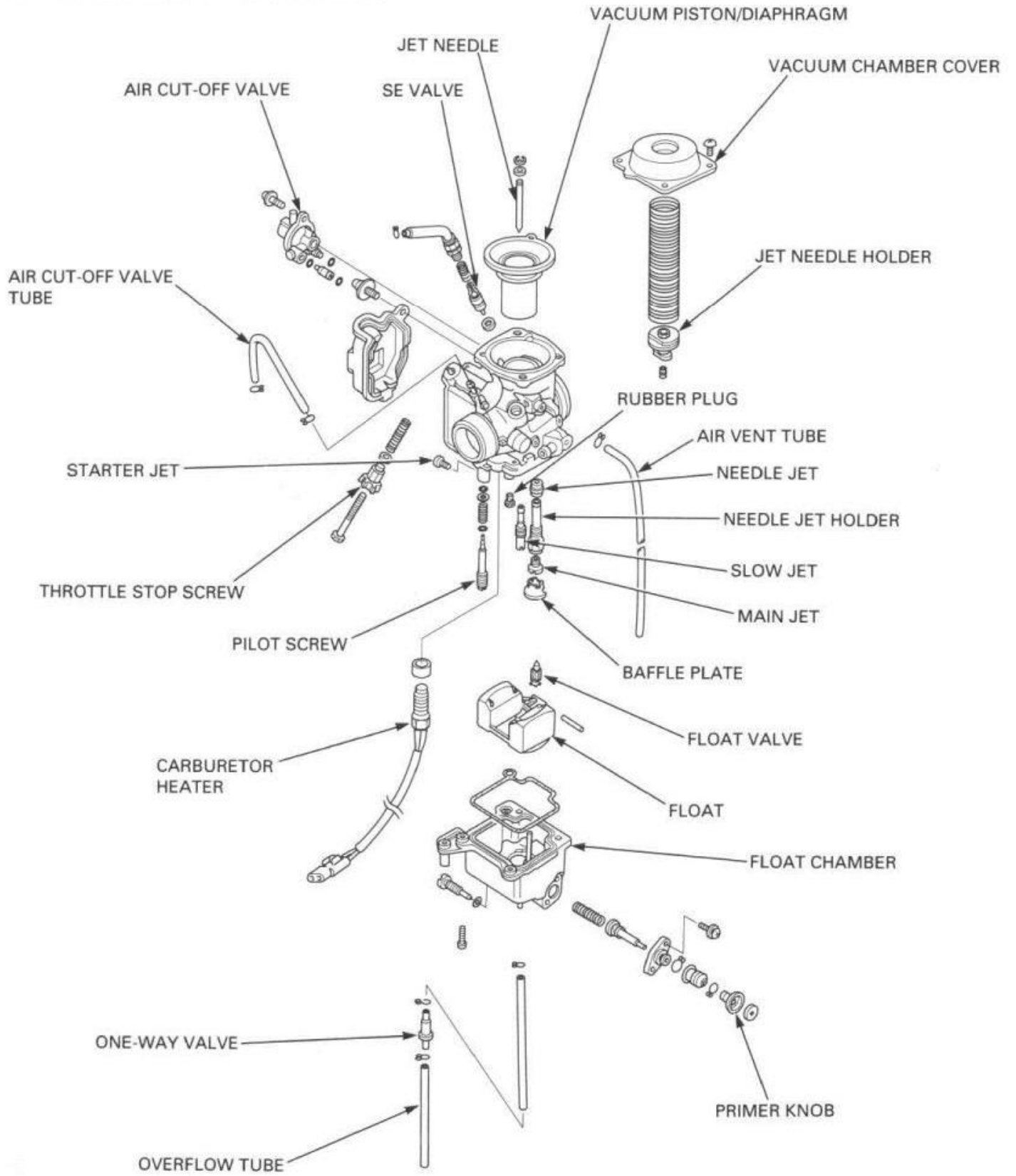

**⚠ WARNING**

*Gasoline is extremely flammable and is explosive under certain conditions. KEEP OUT OF REACH OF CHILDREN.*

Turn the fuel valve off.  
 Remove the side/fuel tank cover (page 2-4).  
 Remove the fuel tank mounting bolts.

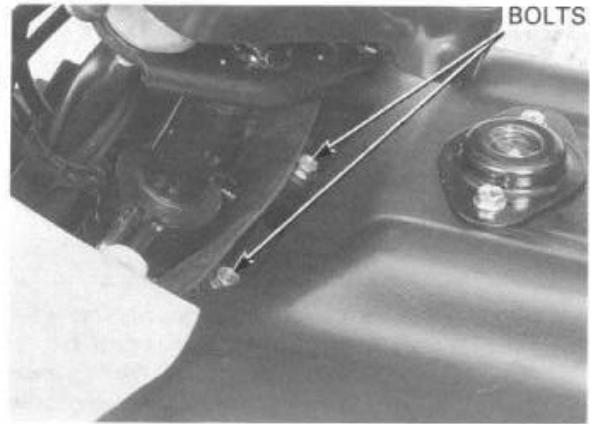

Remove the fuel tank seal rubber.  
 Remove the fuel tank holder bands.



Slightly pull the fuel tank up, then disconnect the fuel tube from the fuel valve.  
 Remove the fuel tank.

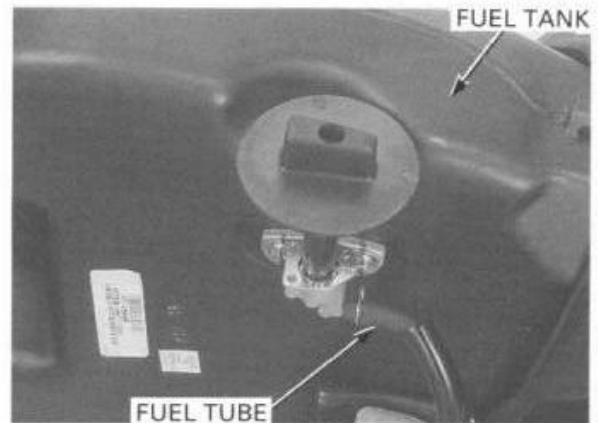

Disconnect the carburetor air vent tube from the fuel tank heat guard.  
 Remove the three retaining clips and fuel tank heat guard.

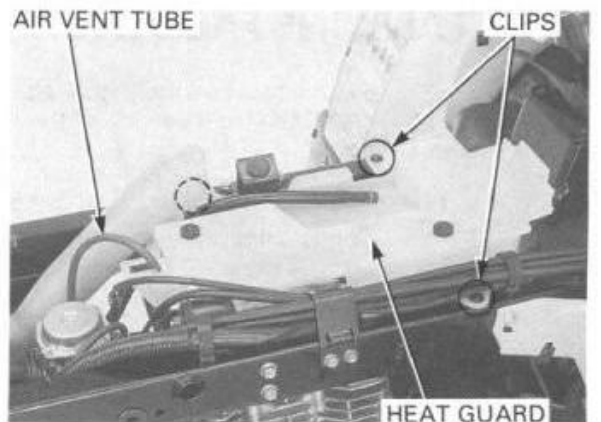

Install and tighten the lower right engine hanger mounting rubbers, collar and hanger bolt/nut to the specified torque.

**TORQUE: 54 N·m (5.5 kgf·m, 40 lbf·ft)**

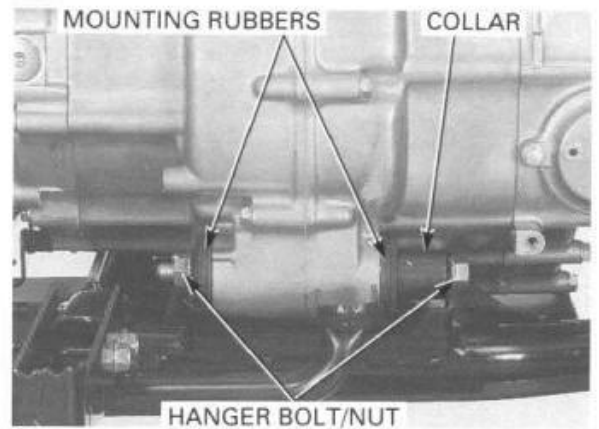

Install the upper hanger plate, engine hanger bracket, bracket bolts, mounting rubbers and hanger bolt.

First tighten the hanger bracket bolts to the specified torque.

**TORQUE: 32 N·m (3.3 kgf·m, 24 lbf·ft)**

Tighten the upper engine hanger bolt to the specified torque.

**TORQUE: 54 N·m (5.5 kgf·m, 40 lbf·ft)**

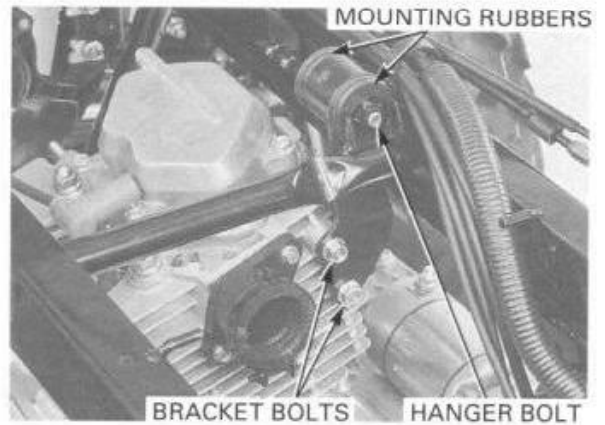

Apply molybdenum disulfide grease to the propeller shaft splines.  
Install the front propeller shaft.

Connect the propeller shaft to the engine over the O-ring while pulling back the propeller shaft joint. Rotate the shaft slightly if necessary to align the splines.

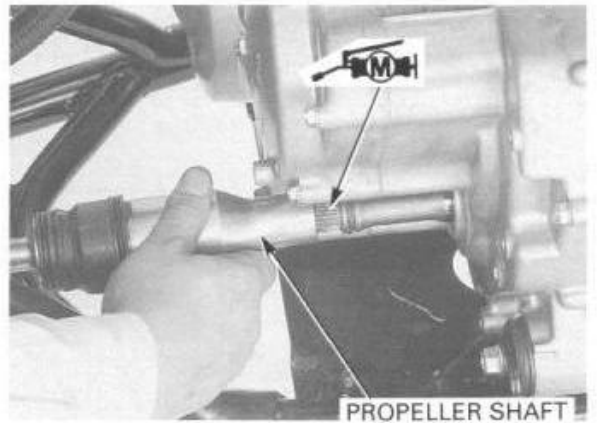

Tighten the rear mounting bolt to the specified torque.

**TORQUE: 44 N·m (4.5 kgf·m, 33 lbf·ft)**

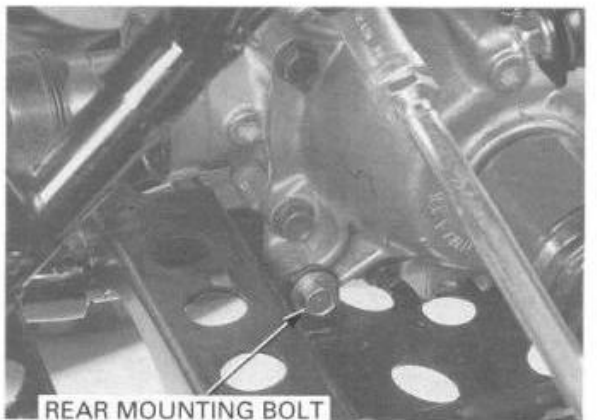

**CYLINDER HEAD REMOVAL**

Remove the timing hole cap.

Turn the crankshaft with the recoil starter and align the "T" mark on the flywheel with the index mark on the rear crankcase cover.

Make sure the piston is at TDC of the compression stroke by moving the rocker arms. If the rocker arms are tight, turn the crankshaft one full turn and realign the "T" mark with the index mark.

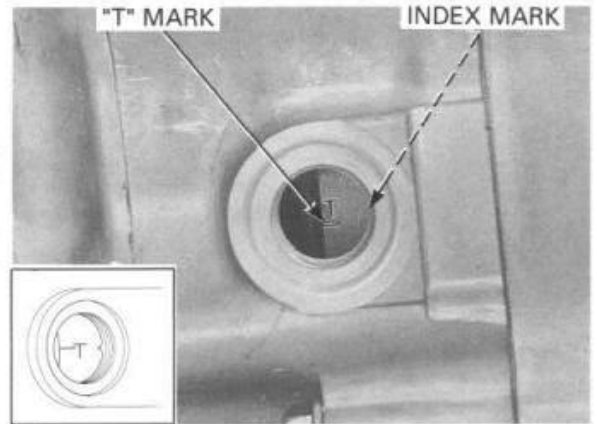

Remove the following:

- Exhaust pipe (page 2-15)
- Carburetor (page 5-5)
- Spark plug cap

Remove the bolts and carburetor insulator. Remove the upper engine hanger bolts, bracket bolts and engine hanger.

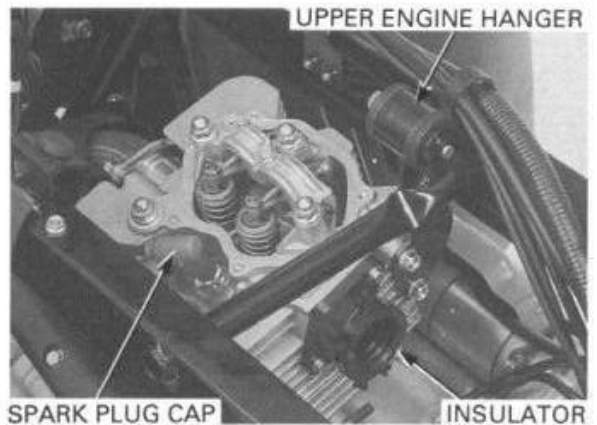

Remove the left fuel tank bracket mounting bolts and bracket.

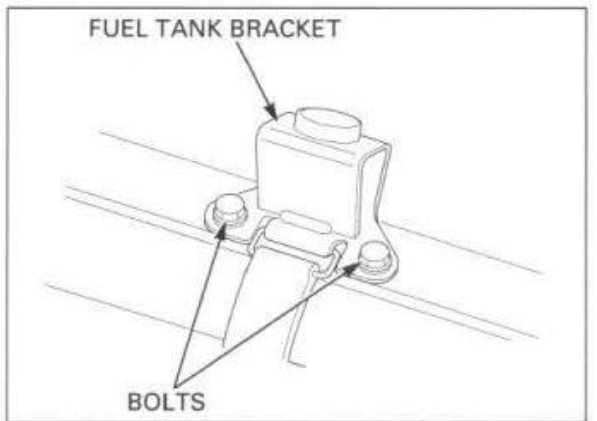

Remove the 6 mm cylinder head mounting bolts.

Loosen the six cylinder head cap nuts in a crisscross pattern in 2 or 3 steps. Remove the washers.

Remove the rocker arm holder assembly.

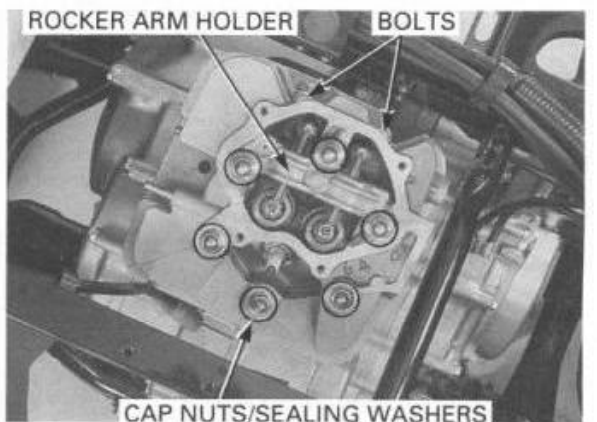

## ROCKER ARM HOLDER INSTALLATION

Properly install the push rods into the center groove of the cam follower.

### NOTE:

If reusing, install the push rods in their original locations as marked.

Install the two dowel pins.

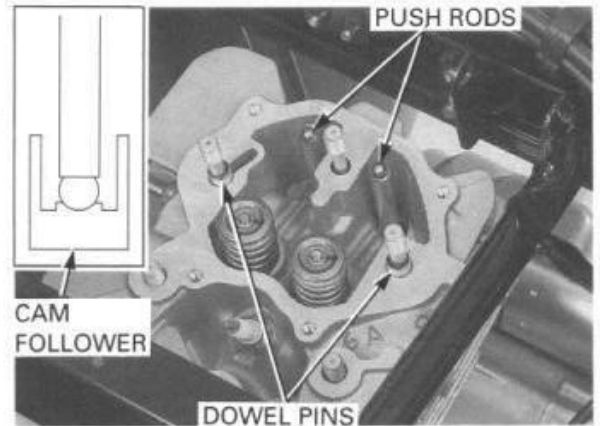

Turn the crankshaft clockwise using the recoil starter knob, and align the "T" mark on the flywheel with the index mark on the rear crankcase cover. Make sure the piston is at TDC on the compression stroke.

If not, rotate the crankshaft 360° (1 full turn) and align the "T" mark with the index mark.

Install the rocker arm holder onto the cylinder head. Install the new washers and cap nuts.

Tighten the cap nut in a crisscross pattern in 2 – 3 steps.

**TORQUE: 39 N·m (4.0 kgf·m, 29 lbf·ft)**

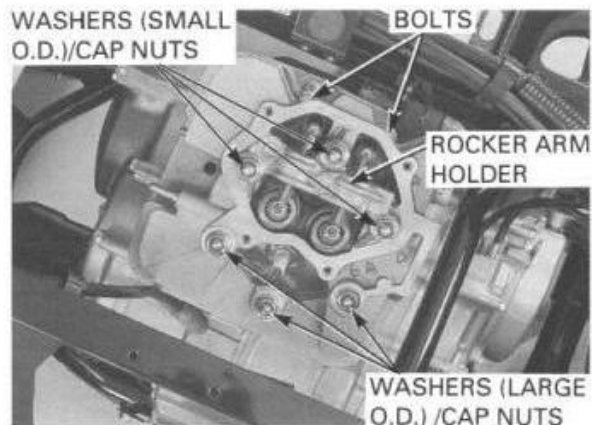

Install and tighten the cylinder head mounting 6 mm bolts.

Install the upper engine hanger bracket, and tighten bracket bolts and the hanger bolt.

### TORQUE:

**Bracket bolt: 32 N·m (3.3 kgf·m, 24 lbf·ft)**

**Hanger bolt: 54 N·m (5.5 kgf·m, 40 lbf·ft)**

Check the O-ring is in good condition, install the carburetor insulator. Tighten the insulator bolts.

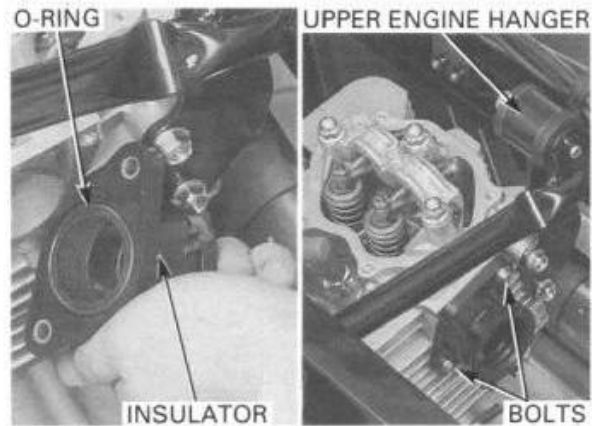

Install the fuel tank bracket and tighten the bolts.

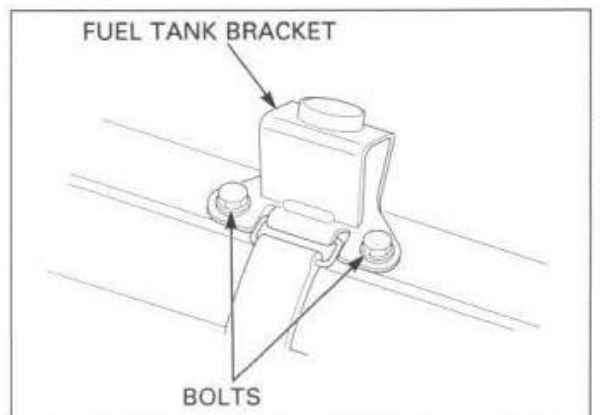

### CAM CHAIN TENSIONER INSTALLATION

Apply a locking agent to the threads of the mainshaft bearing retainer bolts.  
Install the mainshaft bearing retainer/cam chain tensioner, tighten the bolts.

Install the cam chain slipper and oil pump (page 4-11).

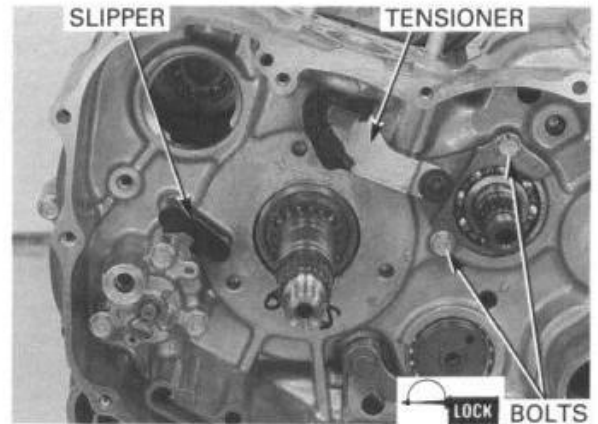

### CAMSHAFT INSTALLATION

Align the "T" mark on the flywheel with the index mark on the rear crankcase by turning the recoil starter.

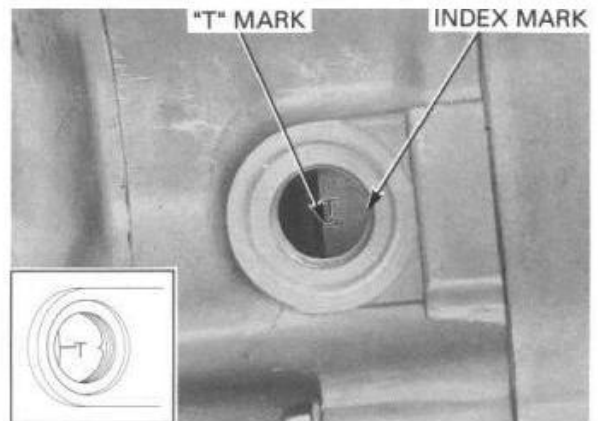

Apply molybdenum disulfide oil to the camshaft lobes and apply oil to the camshaft journal.  
Install the camshaft and camchain into the crankcase with its cam lobes facing down.

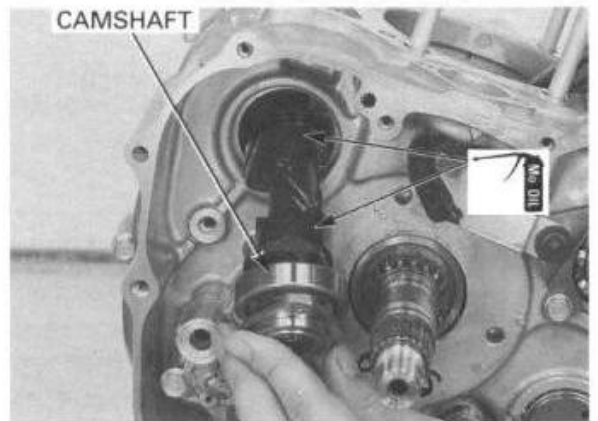

Install the camshaft bearing retainer aligning the groove of the retainer with the crankcase boss.  
Apply a locking agent to the retainer bolt threads.  
Install and tighten the bolts.

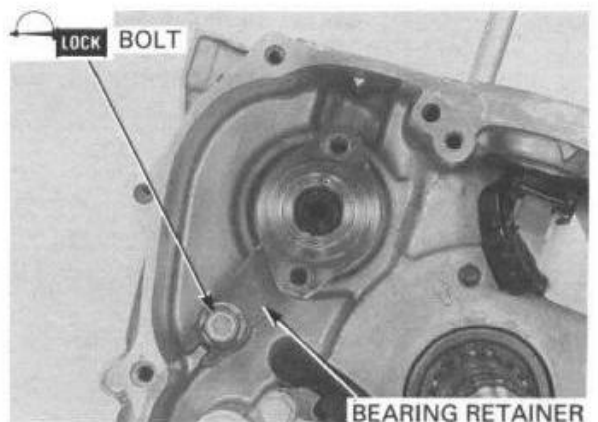

**Primary drive gear**

Inspect the primary drive gear for damage or excessive wear.

Measure the primary drive gear I.D.

**SERVICE LIMIT: 27.05 mm (1.065 in)**

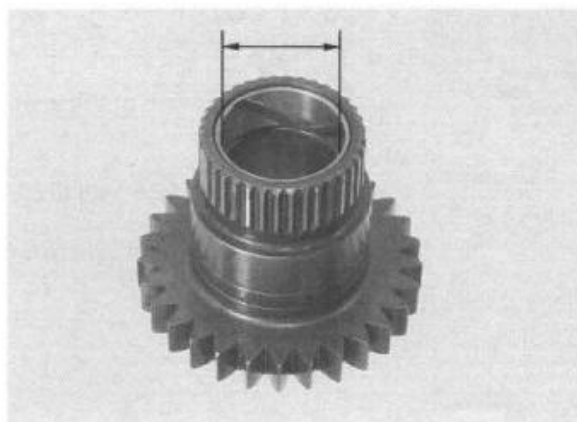
**Weight spring/clutch spring**

Remove the E-clips using screw driver.

**CAUTION:**

*When compressing the clutch spring, be careful not to damage the clutch weight assembly.*

Remove the following:

- Out side washer
- Clutch spring
- Inside washer

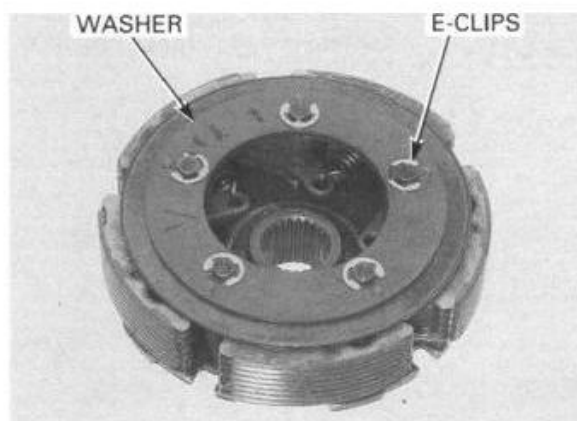

Remove the weight springs and clutch weights from the drive plate.

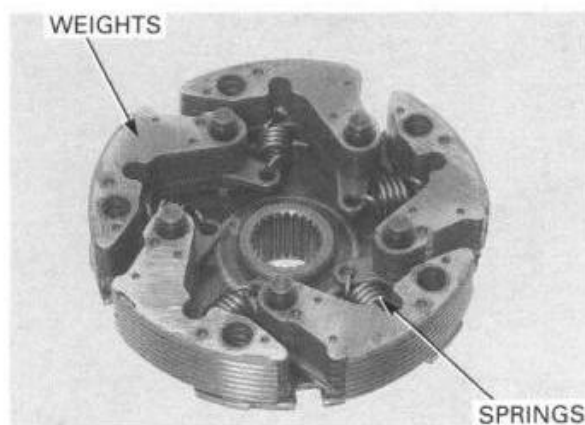

Measure the height of the clutch spring.

**SERVICE LIMIT: 2.95 mm (0.116 in)**

Replace the spring if it is shorter than the service limit.

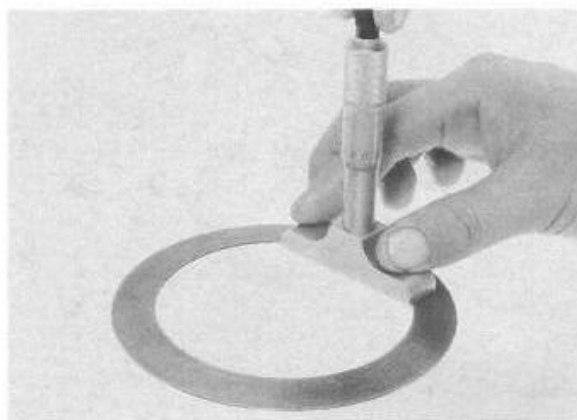

Assemble the clutch pressure plate, discs, plates and clutch center, and install them in the clutch outer. Coat new clutch discs with clean engine oil. Stack the discs and plates alternately.

**NOTE:**

Be sure the clutch center and pressure plate grooves are properly aligned, or the clutch will not operate properly.

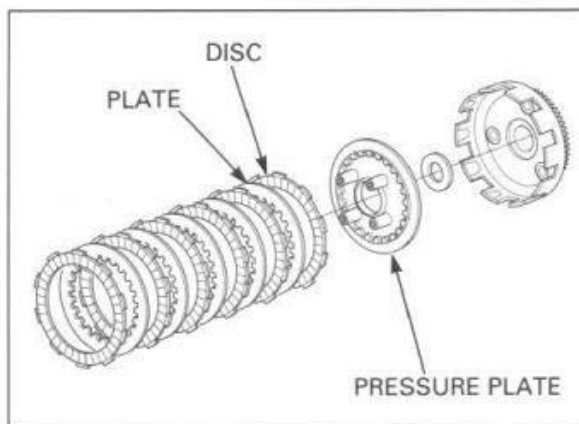

Install the washer on the mainshaft.

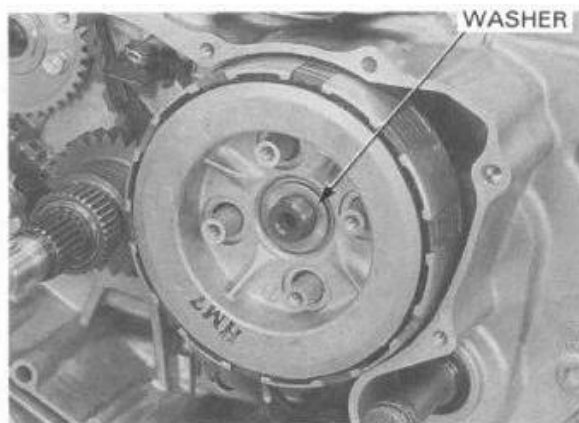

Apply oil to the new lock nut threads. Install a new lock nut. Hold the clutch center using the special tool and four 6 X 55 mm bolts. Tighten the lock nut to the specified torque.

**TOOLS:**

Clutch center holder 07JMB-MN50300  
Holder plate 07HGB-001010B (U.S.A. only) or 07HGB-001010A (U.S.A. only)

Holder collar 07HGB-001020B (U.S.A. only) or 07HGB-001020A (U.S.A. only)

**TORQUE: 108 N·m (11.0 kgf·m, 80 lbf·ft)**

Stake the clutch center lock nut.

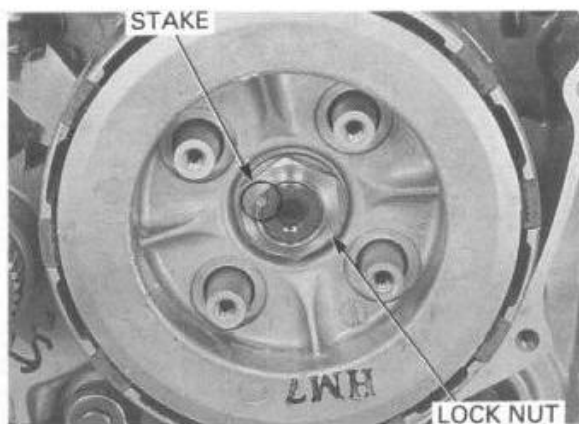
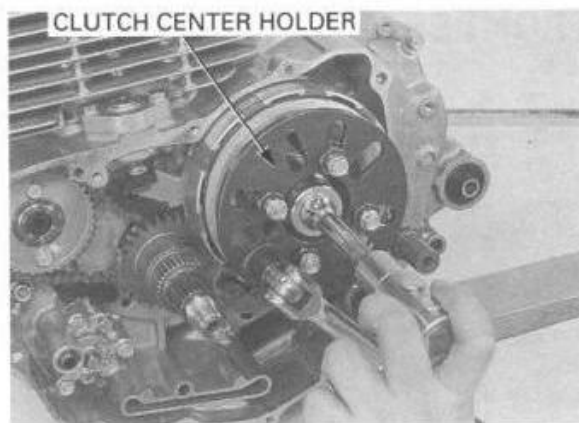

Install the new lock washer and bolt, then tighten the bolt to the specified torque.

**TORQUE: 25 N·m (2.5 kgf·m, 18 lbf·ft)**

Bend the tab of the lock washer against the bolt.

Install the following

- Rear crankcase cover (page 10-12)
- Flywheel / starter clutch (page 10-13)
- Alternator cover (page 10-14)

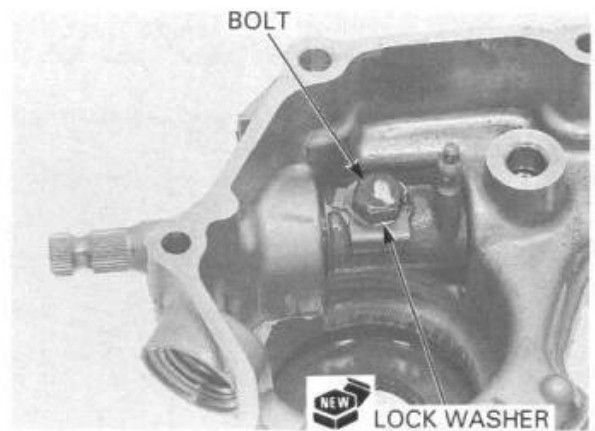

*TRX450S/FM:* Install the gearshift pedal onto the gearshift spindle by aligning the punch marks. Tighten the bolt to the specified torque.

**TORQUE: '98 - '01: 16 N·m (1.6 kgf·m, 12 lbf·ft)**  
**After '01: 20 N·m (2.0 kgf·m, 14 lbf·ft)**

Install the removed parts in the reverse order of removal.

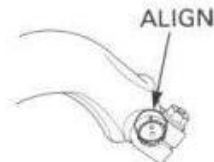
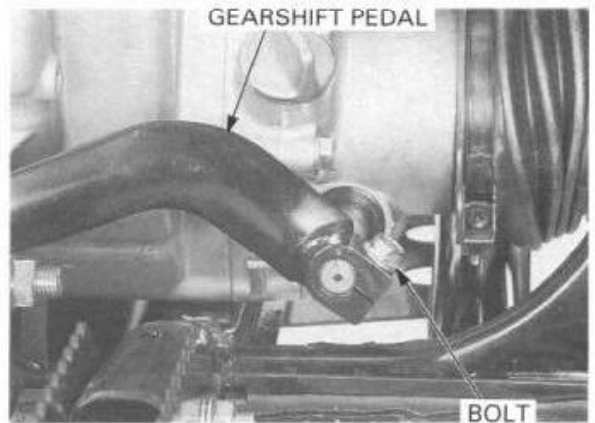

## REVERSE STOPPER SHAFT

### REMOVAL

Remove the bolt and reverse stopper arm.  
 Remove the rear crankcase cover (page 10-9).

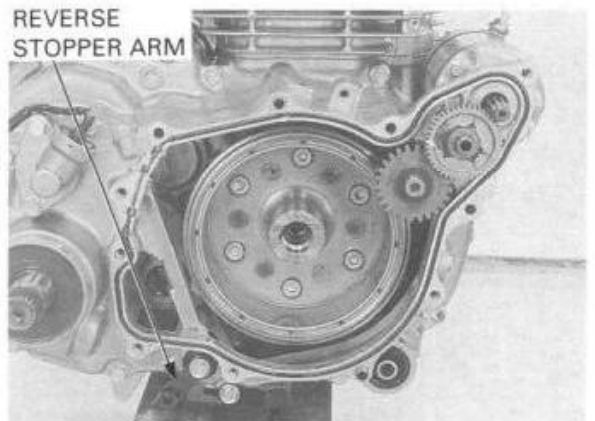

Remove the washer from the reverse stopper shaft.

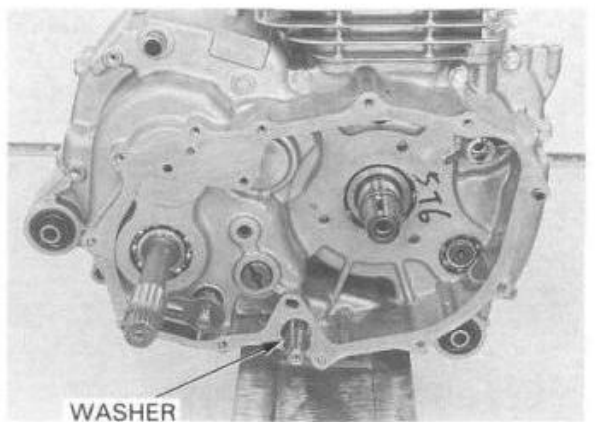

## ALTERNATOR/STARTER CLUTCH

Hold the starter driven pulley using the special tool, then remove the bolt and O-ring.

**TOOL:**  
Recoil pulley holder                    07SMB-HM70100

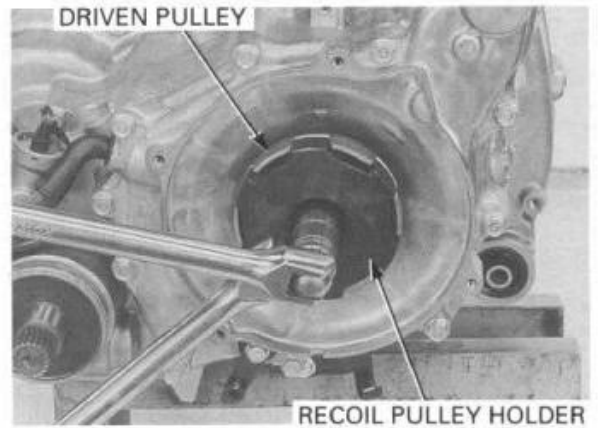

Remove the eleven bolts and alternator cover.

**NOTE:**

The starter reduction gears may fall out as the cover is removed.

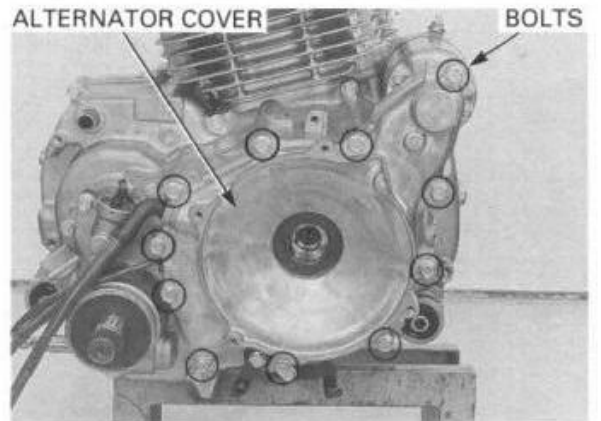

Remove the O-ring and dowel pins.

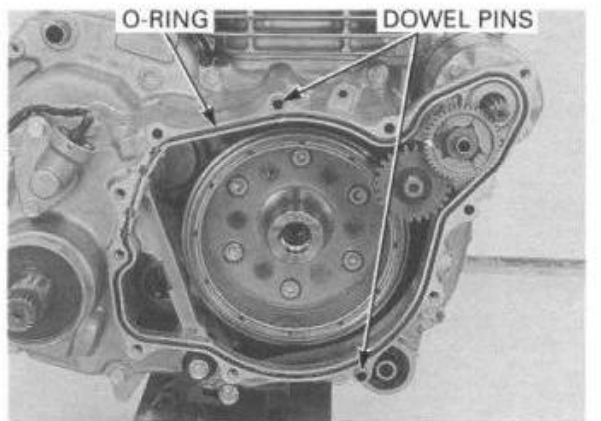

### ALTERNATOR COVER DISASSEMBLY

Disconnect the ignition pulse generator connector. Remove the wire grommet from the alternator cover groove.

Remove the ignition pulse generator and stator mounting bolts.  
Remove the stator/ignition pulse generator assembly.

Remove the bolt and neutral/reverse (gear position) switch.

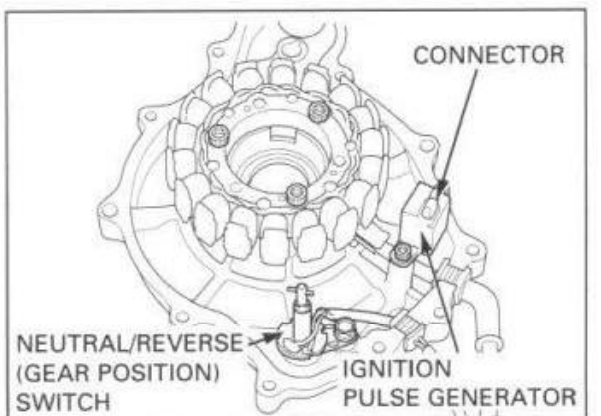

Connect the thermosensor connector to the sensor.

Connect the reverse control cable end to the lever.

Adjust the reverse selector lever free play (page 3-18).

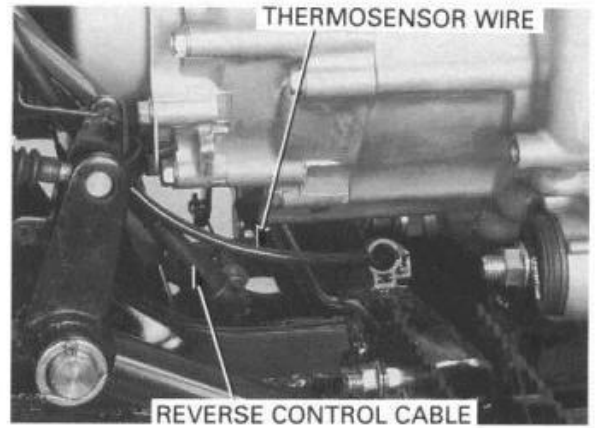

**REAR CRANKCASE**

Drive out the final shaft bearing from the rear crankcase.

Remove the rear crankcase bearings using the special tools.

**TOOLS:**

**Mainshaft, camshaft and shift drum bearings:**

- Remover handle** 07936-3710100
- Bearing remover, 17 mm** 07936-3710300
- Remover weight** 07741-0010201 or 07936-3710200 or 07936-371020A (U.S.A. only)

**Countershaft bearing:**

- Bearing remover set** 07936-3710001 (Not available in U.S.A.)
- Remover handle 07936-3710100
- Bearing remover, 20 mm 07936-3710600
- Remover weight 07741-0010201 or 07936-371020A or 07936-3710200 (U.S.A. only)

*Make sure bearing puller is inside case lip before removing shift drum needle bearing.*

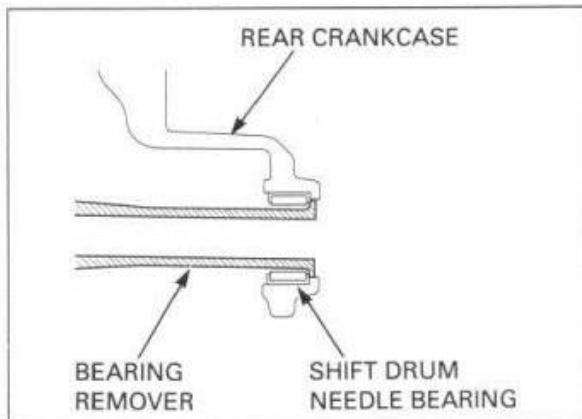
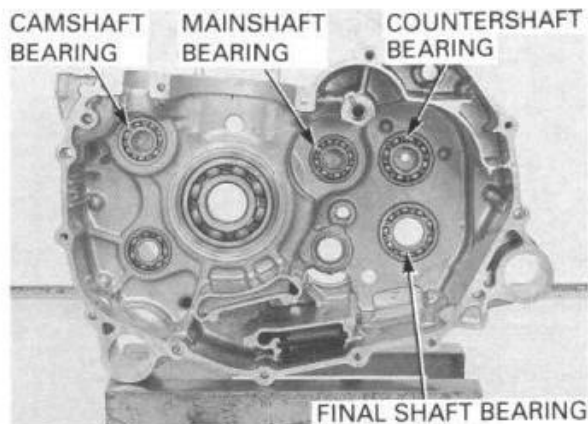

Drive new bearings into the rear crankcase.

**TOOLS:**

- Driver** 07749-0010000
- Countershaft bearing:**
  - Attachment, 42 X 47 mm** 07746-0010300
  - Pilot, 20 mm** 07746-0040500
- Mainshaft/camshaft bearing:**
  - Attachment, 37 X 40 mm** 07746-0010200
  - Pilot, 17 mm** 07746-0040400
- Final shaft bearing:**
  - Attachment, 52 X 55 mm** 07746-0010400
  - Pilot, 25 mm** 07746-0040600

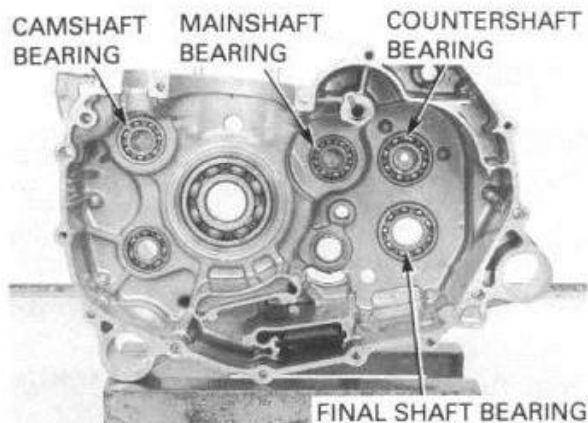

Press the shift drum needle bearing using the special tools and hydraulic press.

**TOOLS:**

- Driver** 07749-0010000
- Attachment, 24 X 26 mm** 07746-0010700

Install the rear crankcase on the front crankcase.  
Install the threaded adapter on the crankshaft.

**TOOL:**  
**Threaded adapter** 07965-VM00300 or  
07931-KF00200  
(U.S.A. only)

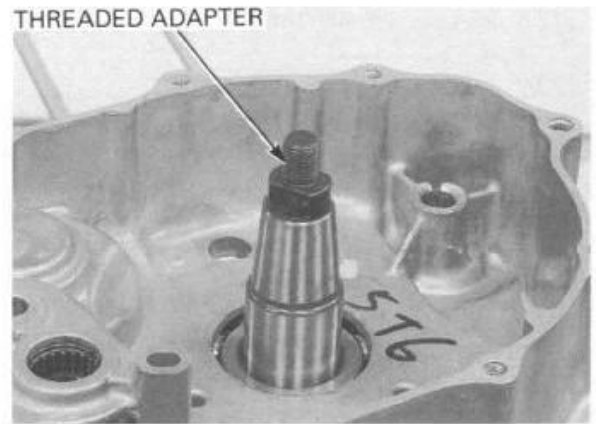

Draw the crankshaft into the rear crankcase using the special tools.

**TOOLS:**  
**Assembly collar** 07965-VM00100  
**Assembly shaft** C7965-VM00200 or  
07931-ME4010B and  
(U.S.A. only)  
**Special nut** 07931-HB3020A

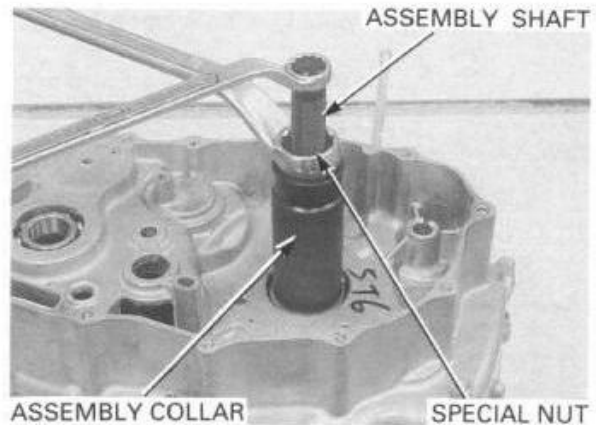

Remove the front crankcase and make sure the index marks on the balancer and crankshaft are aligned.

Install the transmission (page 11-11).

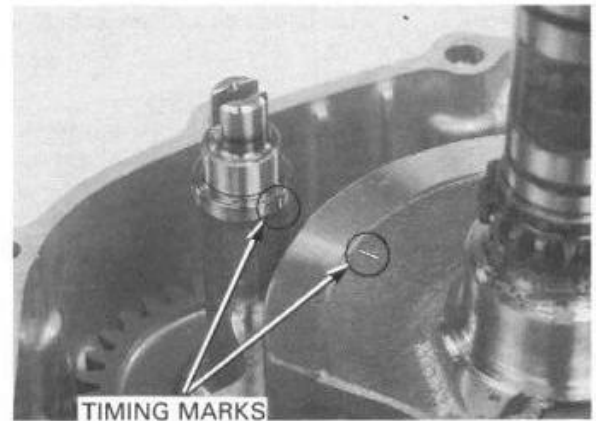

## CRANKCASE ASSEMBLY

Install the dowel pins and new gasket.

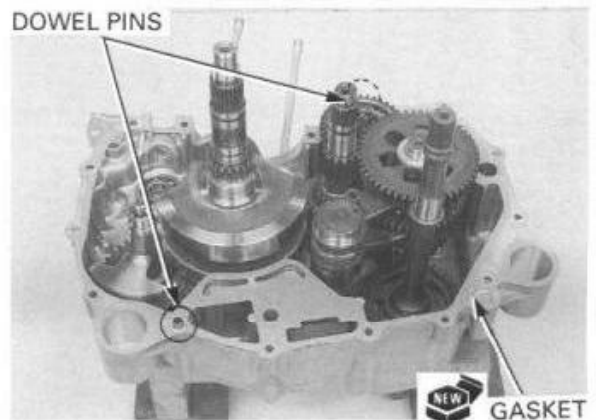

CLICK HERE TO **DOWNLOAD** THE COMPLETE MANUAL

- Thank you very much for reading the preview of the manual.
- You can download the complete manual from: [www.heydownloads.com](http://www.heydownloads.com) by clicking the link below



- Please note: If there is no response to CLICKING the link, please download this PDF first and then click on it.

CLICK HERE TO **DOWNLOAD** THE COMPLETE MANUAL

Slide the rubber boot off the cable adjuster.  
Loosen the throttle cable adjuster.

Bend down the lock washer tab and remove the nut and lock washer.  
Disconnect the throttle cable from the throttle arm.  
Remove the throttle arm, spring and throttle lever from the throttle housing.

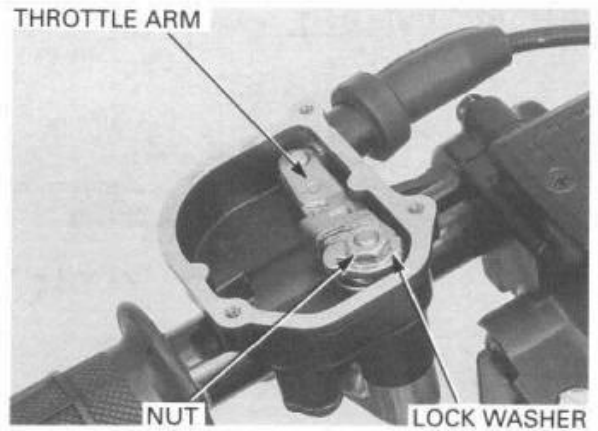

**ASSEMBLY**

Connect the throttle cable to the throttle arm.  
Install the throttle arm spring and arm onto the throttle lever by aligning the slot.

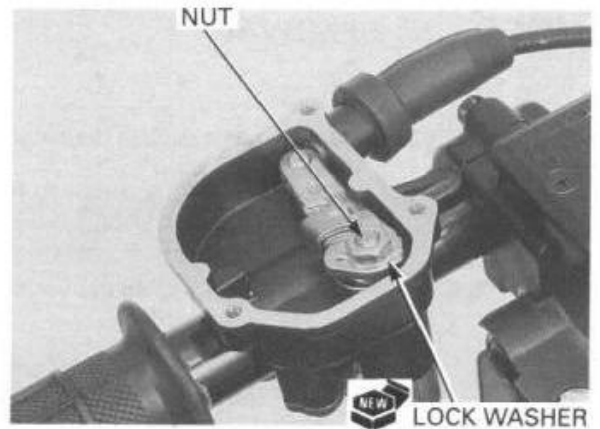
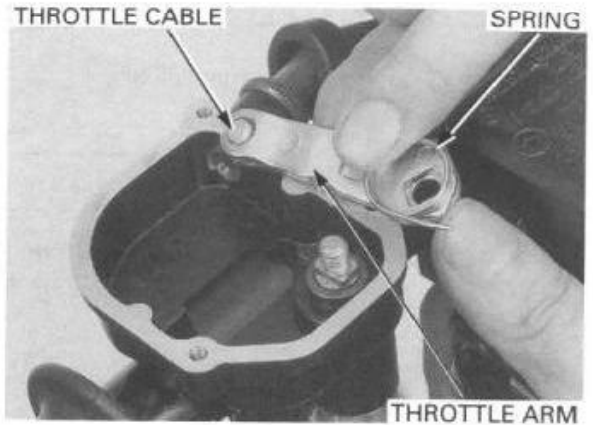

Install a new gasket, then install the throttle housing cover.  
Install and tighten the three screws.

Adjust the throttle lever free play (page 3-4).

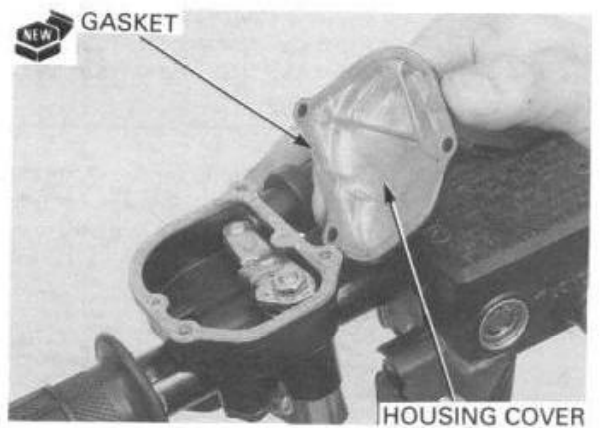

Install a snap ring securely in the knuckle groove.

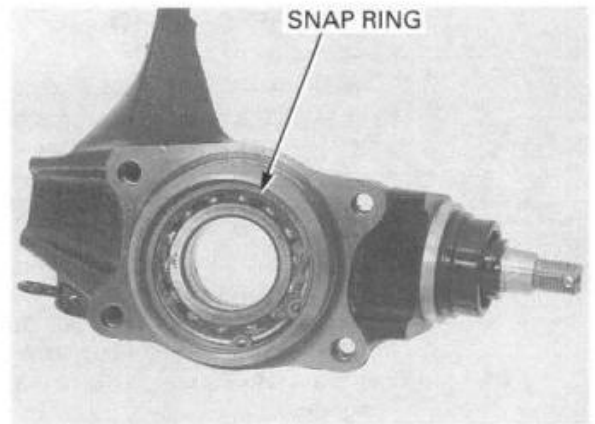

Install new outer dust seals using the special tools.  
Apply grease to the dust seal lips.

**TOOLS:**

Driver	07749-0010000
Attachment, 52 X 55 mm	07746-0010400
Pilot, 30 mm	07746-0040700

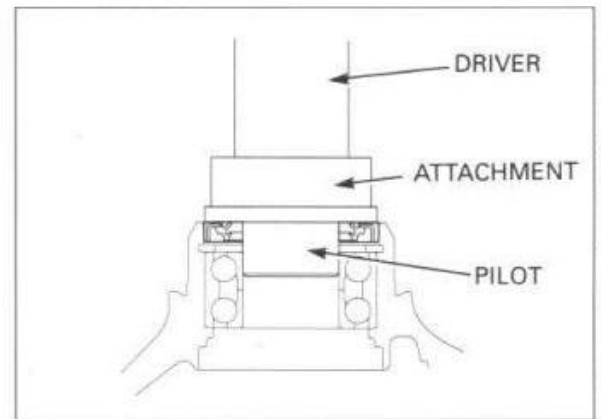

Install new inner dust seals using the special tools.  
Apply grease to the dust seal lips.

**TOOLS:**

Driver	07749-0010000
Oil seal driver	07JAD-PH80101
Pilot, 30 mm	07746-0040700

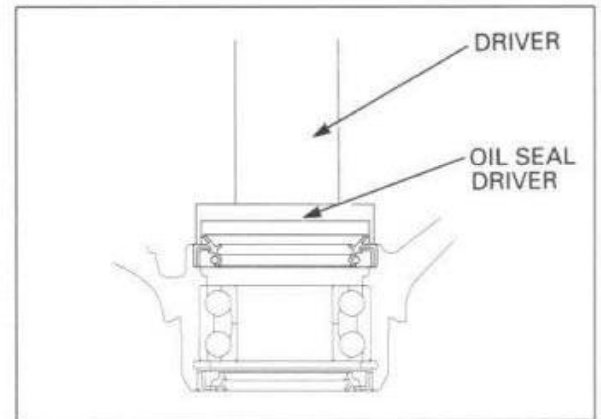

Install the snap ring in the groove securely.

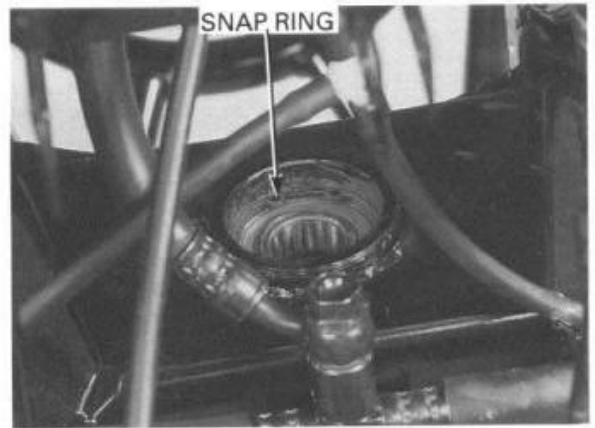

Apply grease to new dust seal.  
Install the dust seals.



Apply grease to new dust seal.  
Install the dust seal.



## INSTALLATION

Apply grease to the steering shaft spline.  
Assemble the steering shaft and steering arm by  
aligning the wide cut-out of the steering arm with  
the wide tooth of the steering shaft.

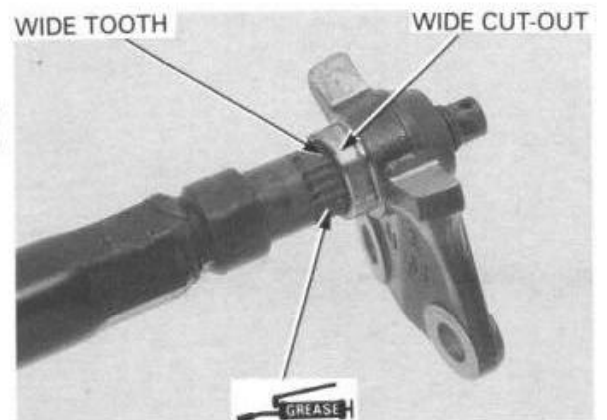

Remove the swingarm pivot cap (each side).

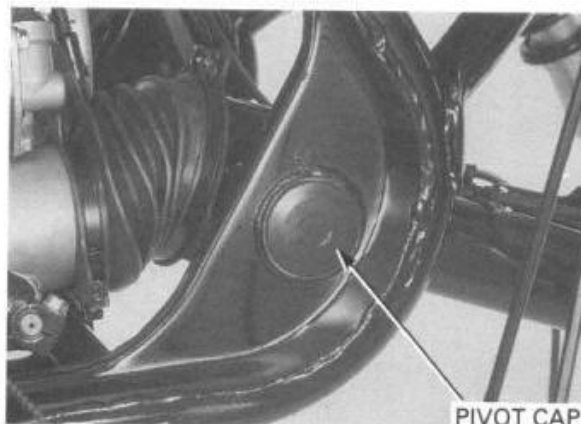

Release the breather tubes from the swingarm clamps.

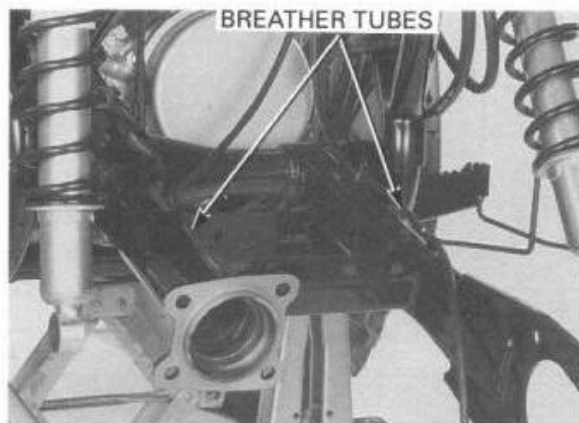

Remove the left pivot bolt using the commercially available tool as shown.

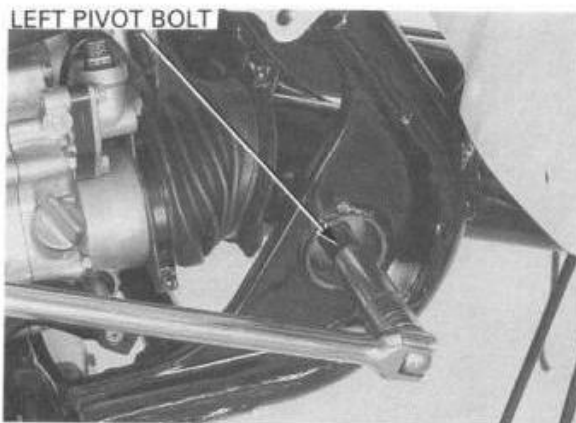

Remove the right pivot lock nut using the special tool as shown.

**TOOL:**  
**Swingarm lock nut wrench 07908-4690003**

Remove the right pivot bolt using a commercially available tool.

Remove the swingarm from the frame.

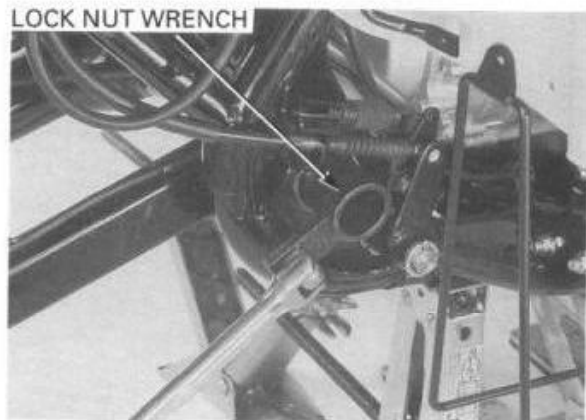

## BRAKE FLUID REPLACEMENT/AIR BLEEDING

### BRAKE FLUID DRAINING

#### CAUTION:

- *Do not allow foreign material to enter the system when filling the reservoir.*
- *Avoid spilling fluid on painted, plastic, or rubber parts. Place a rag over these parts whenever the system is serviced.*

With the fluid reservoir parallel to the ground, remove the reservoir cover and diaphragm.

Connect a bleed hose to the bleed valve. Loosen the bleed valve and pump the brake lever. Stop pumping the lever when no more fluid flows out of the bleed valve.

### BRAKE FLUID FILLING

Fill the reservoir with DOT 3 or 4 brake fluid from a sealed container.

#### CAUTION:

*Do not mix different types of fluid. They are not compatible.*

Connect a commercially available brake bleeder to the bleed valve.

Pump the brake bleeder and loosen the bleed valve, adding fluid when the fluid level in the master cylinder reservoir is low.

#### NOTE:

- Check the fluid level often while bleeding the brakes to prevent air from being pumped into the system.
- When using a brake bleeding tool, follow the manufacturer's operating instructions.

Repeat the above procedure until air bubbles do not appear in the plastic hose.

#### NOTE:

- If air is entering the bleeder from around the bleed valve threads, seal the threads with Teflon tape.
- If a brake bleeder is not available, fill the master cylinder and operate the brake lever to fill the system.

Close the bleed valve. Next, perform the BLEEDING procedure (page 14-4).

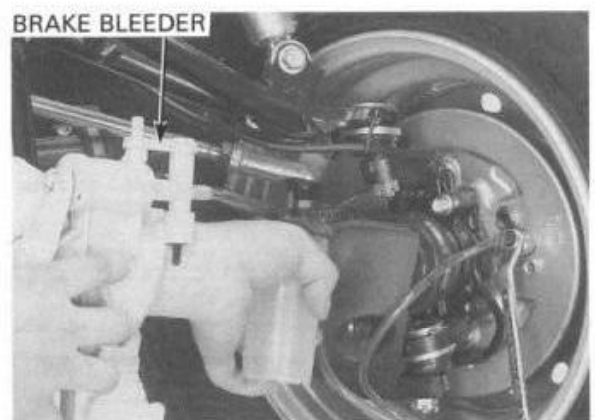
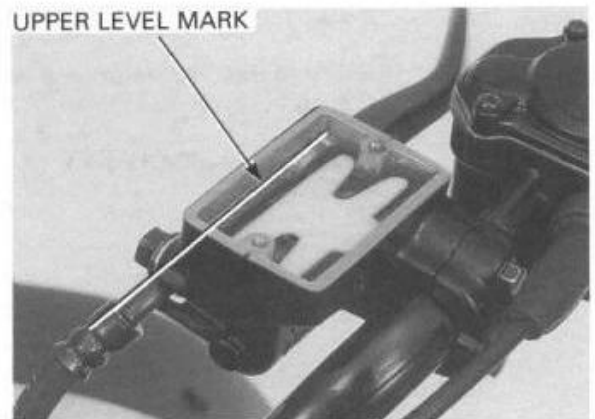
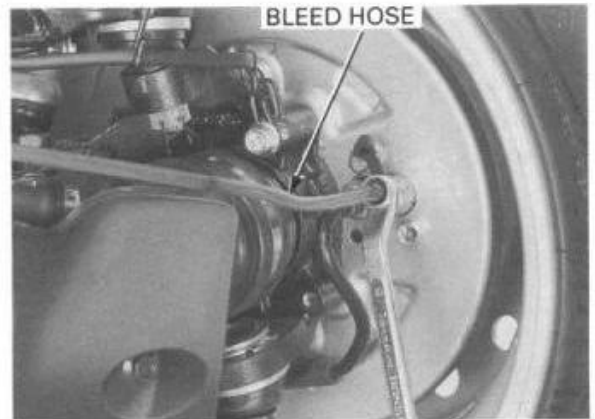
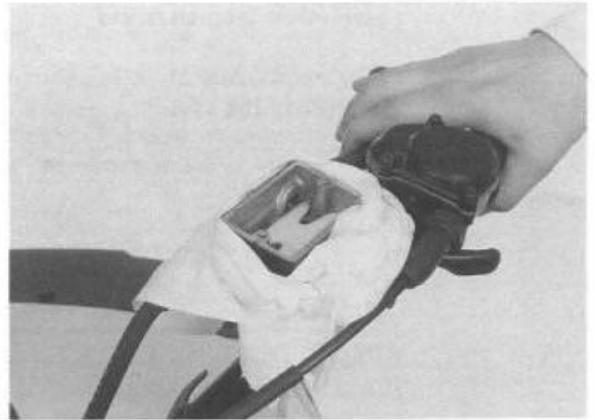

Install the cylinder assembly A and B, and tighten the bolts, washers and nuts.

**TORQUE:**

6 mm bolt: 8 N·m (0.8 kgf·m, 6 lbf·ft)

8 mm nut: 17 N·m (1.7 kgf·m, 12 lbf·ft)

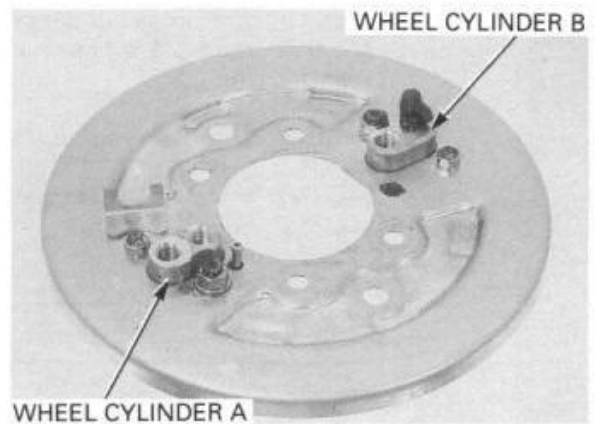

Install the brake pipe as shown by tightening the joint nuts.

**TORQUE: 16 N·m (1.6 kgf·m, 12 lbf·ft)**

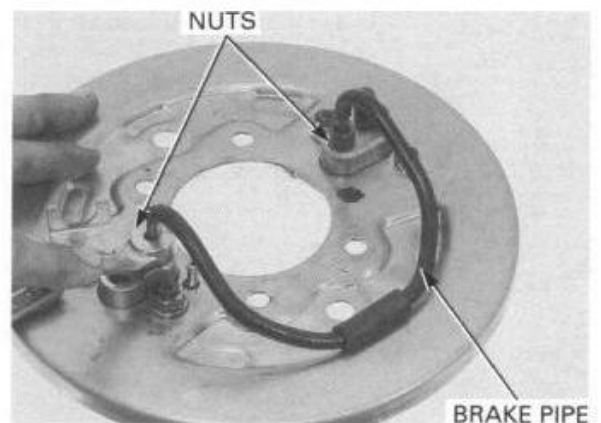

Install a new O-ring on the knuckle.

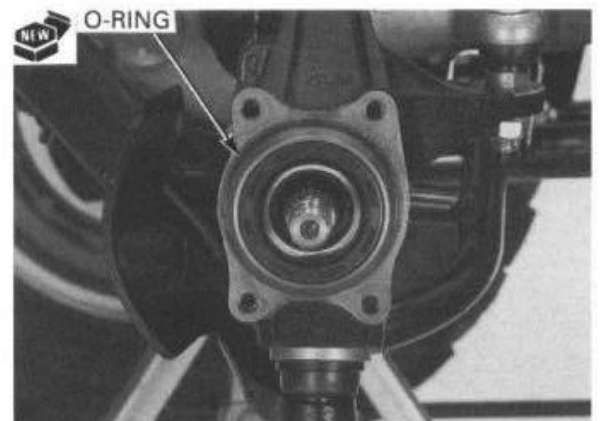

Install the front brake panel assembly and tighten the new brake panel bolts.

**TORQUE: 29 N·m (3.0 kgf·m, 22 lbf·ft)**

**CAUTION:**

*Discard the used panel bolts. Do not reuse the panel bolts because their threads are specially dry-coated for waterproofing.*

Apply silicone grease on the metal contact area indicated.

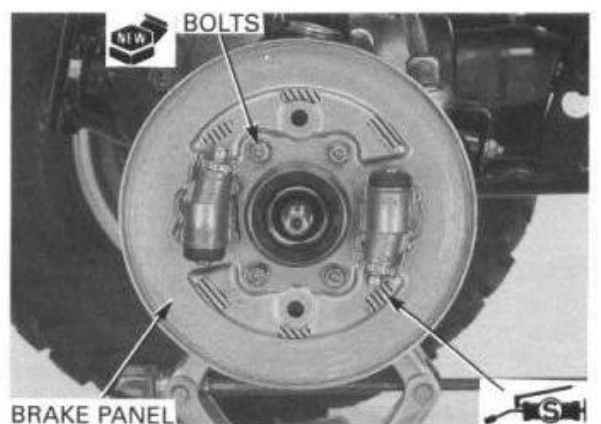

# BRAKE PEDAL

## REMOVAL

Loosen and remove the rear brake pedal adjusting nuts.

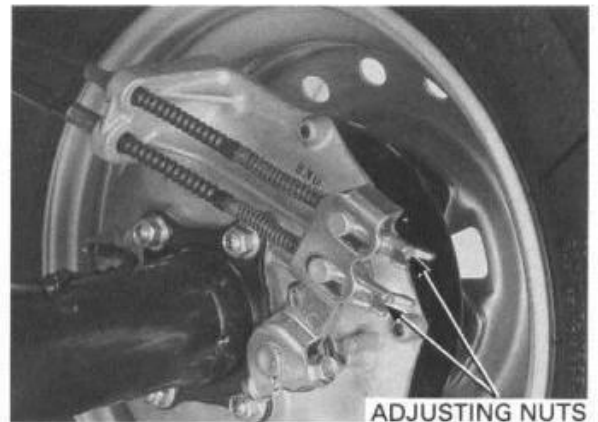

ADJUSTING NUTS

Disconnect the brake cable from the bracket and unhook the return spring. Remove the cotter pin and washer from the pedal pivot shaft, and then remove the brake pedal from the shaft.

Unhook the brake cable from the brake pedal.

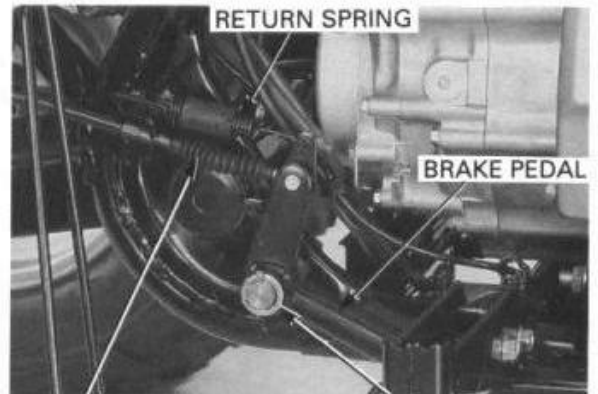

BRAKE CABLE COTTER PIN/WASHER

## INSTALLATION

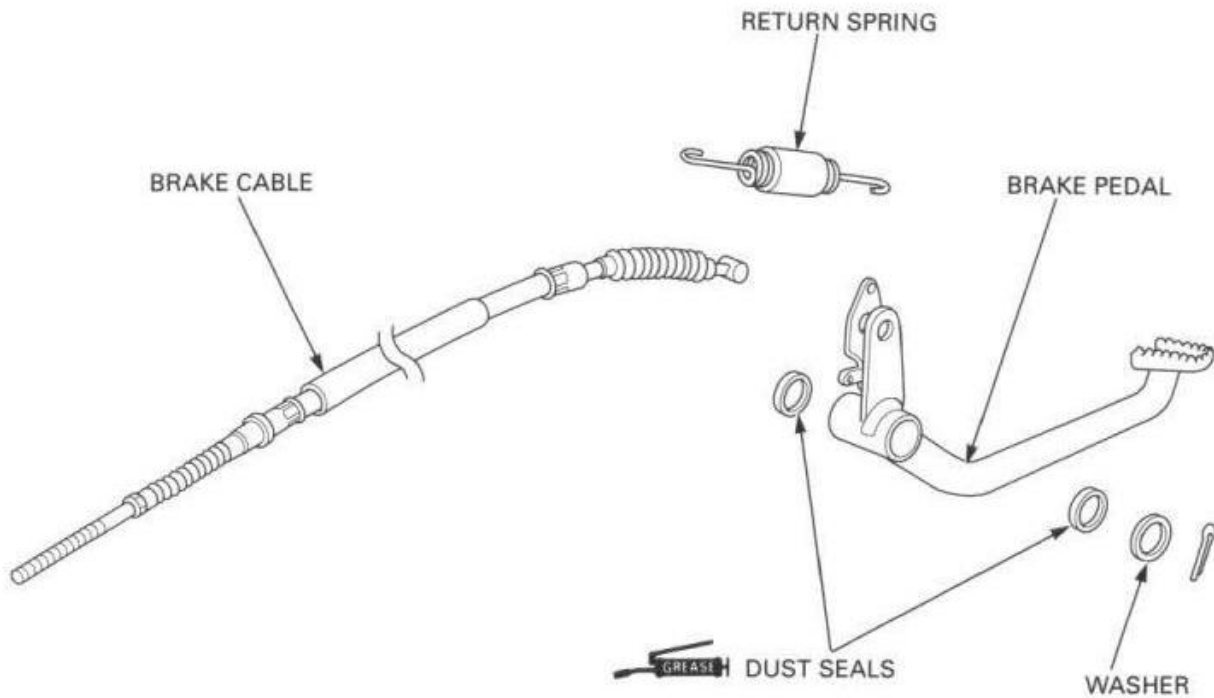

Check the following for wear or damage.

- Bearing cage
- Bearing race
- Steel balls

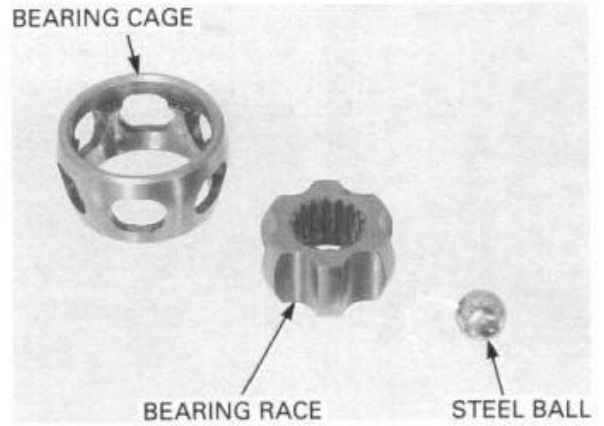

- Inboard joint

**NOTE:**

Replace the bearing cage, bearing race, steel balls and inboard joint as an assembly.

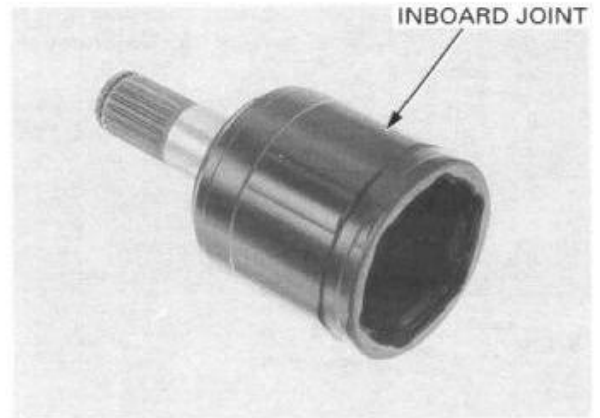

**ASSEMBLY**

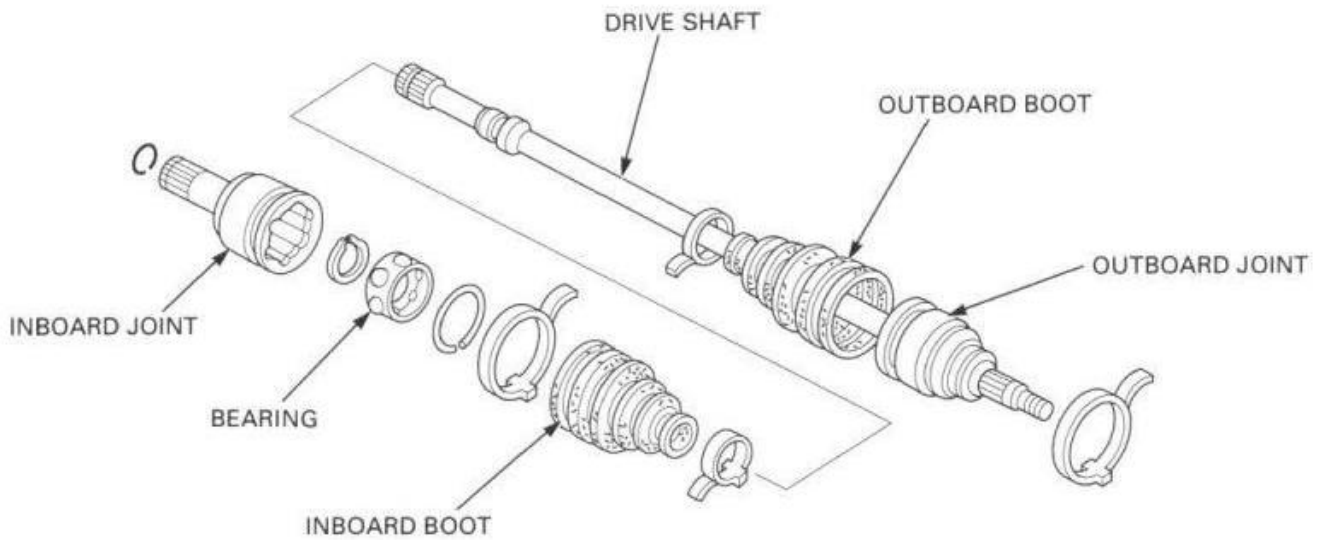

Remove the final clutch mounting bolts and final clutch.

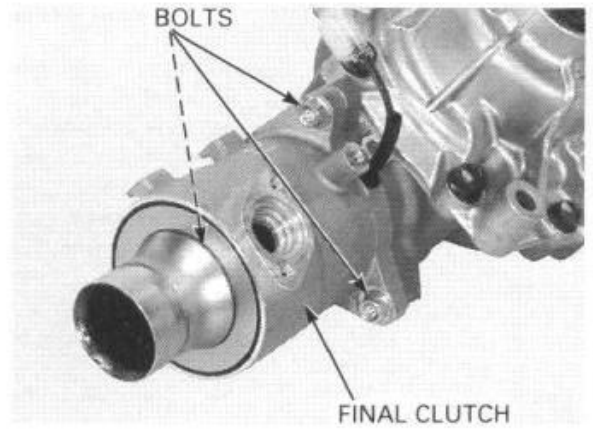

Remove the cover bolts in a crisscross pattern in several steps.

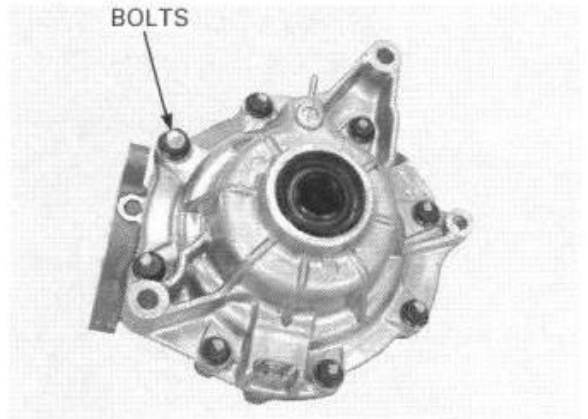

Pry the cover at the prying points using a screwdriver and remove the case cover.

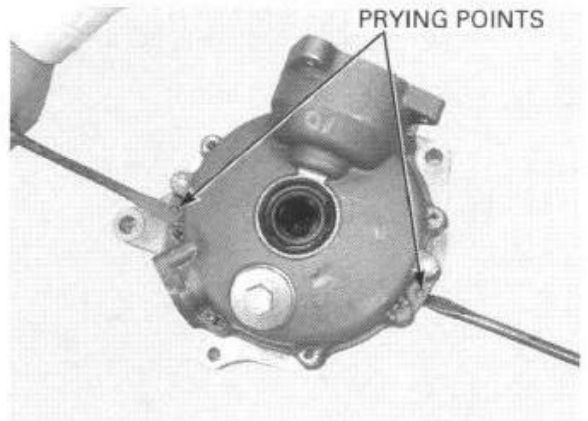

Remove the differential assembly and shims.

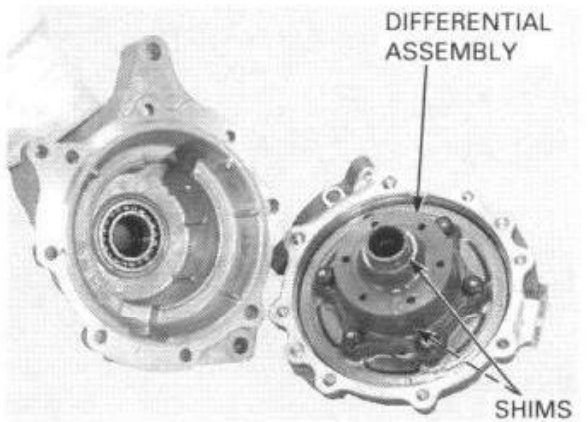



DIFFERENTIAL ASSEMBLY (After '01)

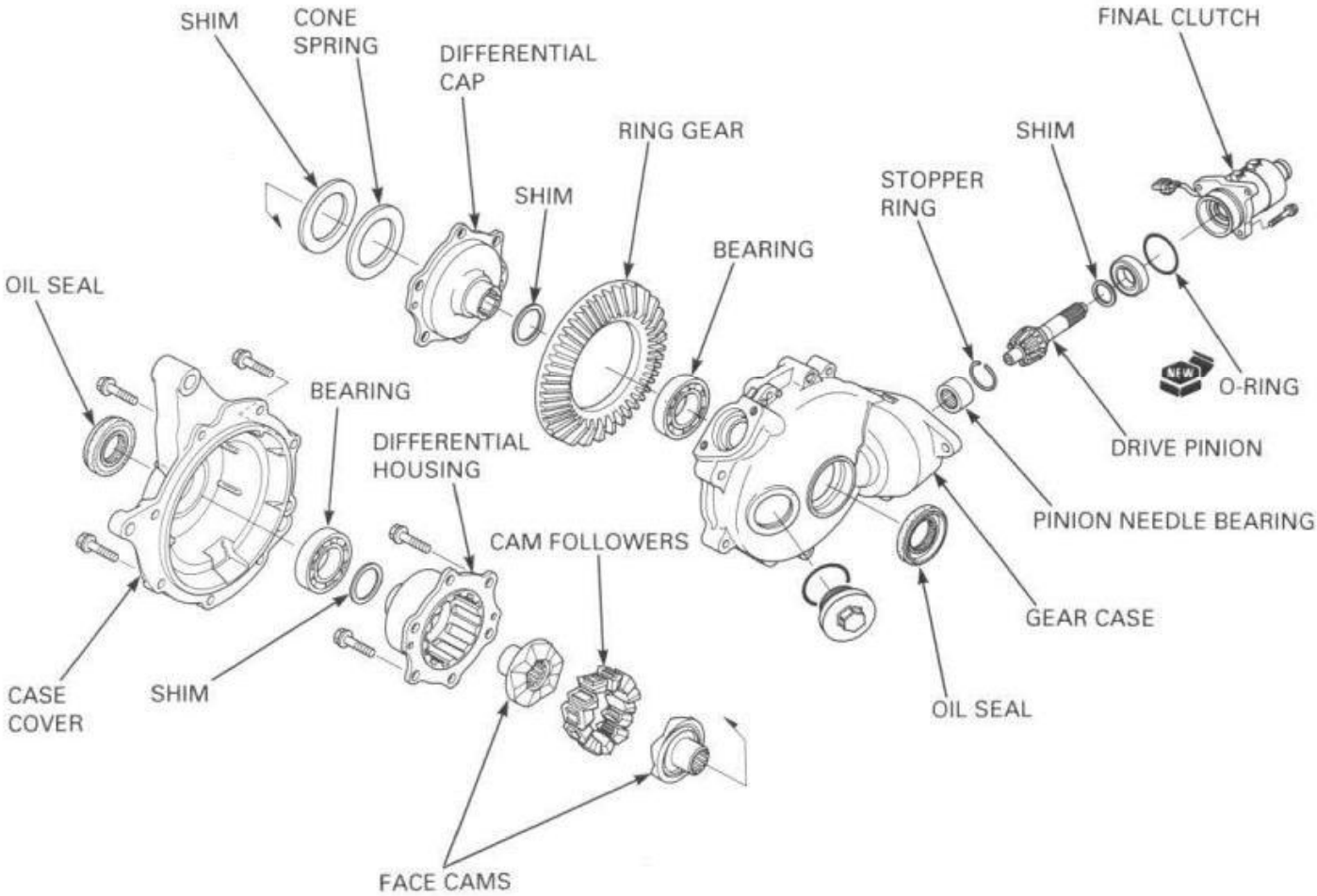

8 mm BOLT: 25 N·m (2.6 kgf·m, 19 lbf·ft)  
10 mm BOLT: 49 N·m (5.0 kgf·m, 36 lbf·ft)

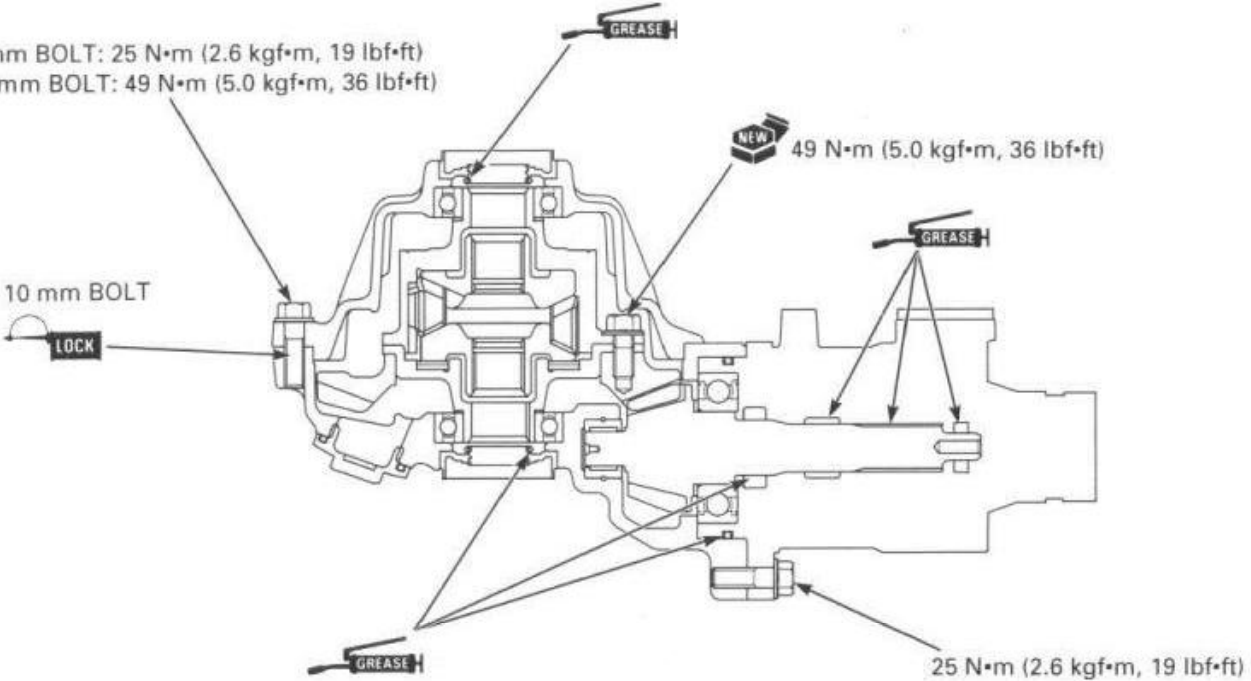

## REAR AXLE REMOVAL

**NOTE:**

It is not necessary to disassemble the brake panel.

Remove the right and left rear wheels (page 13-3).

Remove the cotter pin, axle nut and rear wheel hubs.

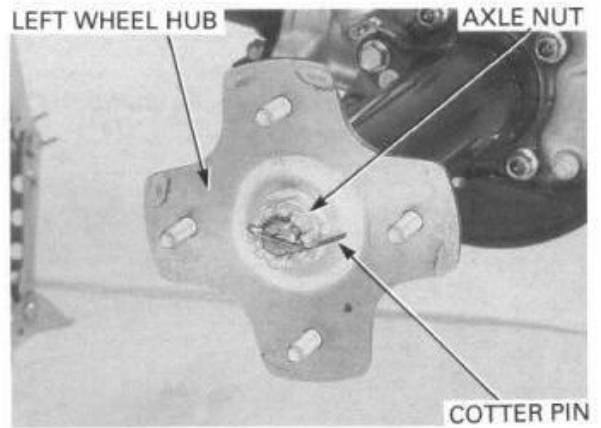

Remove the three bolts and rear final drive skid plate.

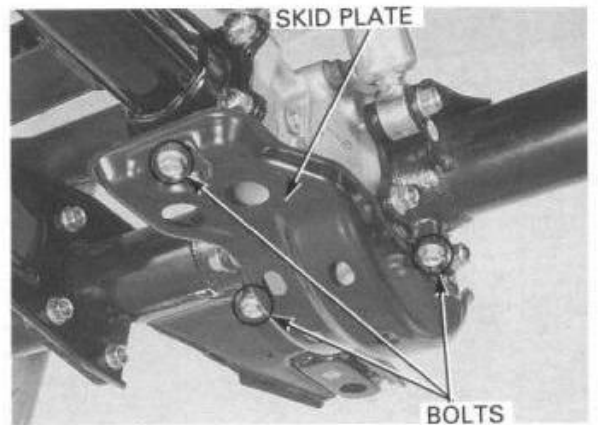

Remove the left shock absorber lower mounting bolt.

Remove the nuts and left rear axle housing and O-ring.  
Discard the mounting nuts.

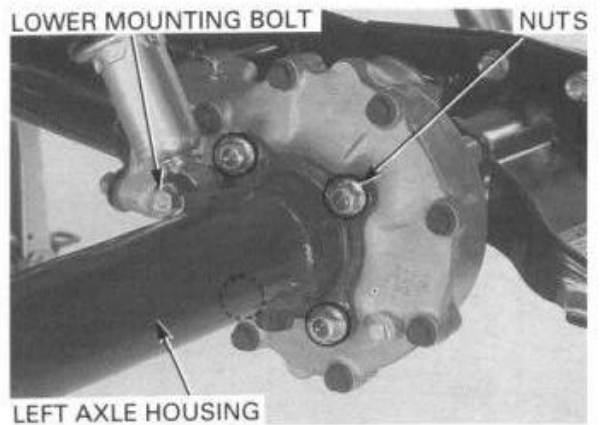

Remove the collar from the axle shaft.

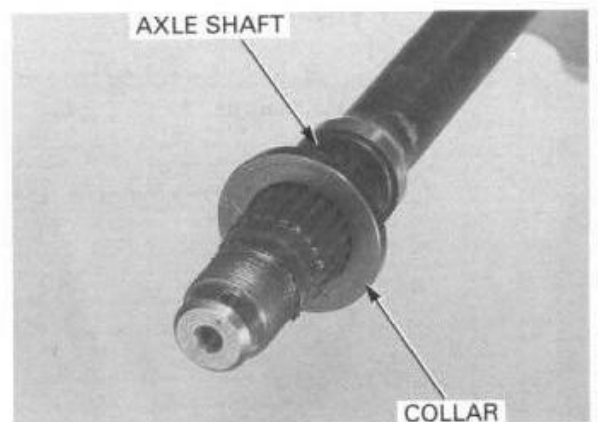

Install the stopper ring into the groove in the bearing. Install the bearing into the compressor until the bearing is flush with the end of the tool. Place the driver on top of the bearing and tape the driver to the compressor. Place the assembly into a freezer for at least 30 minutes.

**TOOLS:**

**Driver** 07749-001000  
**Differential bearing ring compressor** 07YME-HN4010A

'98 - '01 **Attachment 24 × 26 mm** 07746-0010700  
 After 01: **Attachment 22 × 24 mm** 07746-0010800  
 After 01: **Pilot, 14 mm** 07746-0041200

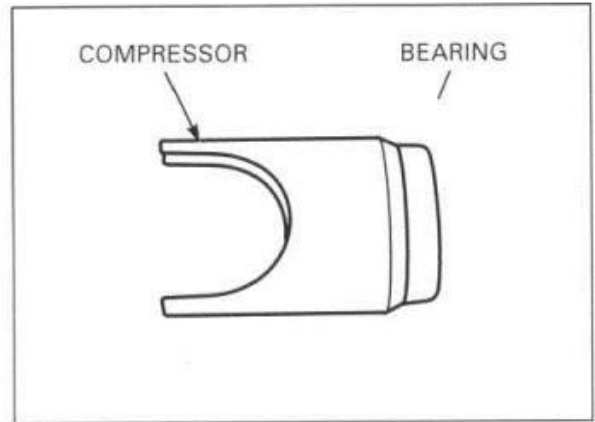

Heat the gear case to 80°C (176°F).

Remove the needle bearing and tool assembly from the freezer and drive the bearing into the gear case using the special tools.

Only strike the driver once. If you strike it more than once, the ring may slip out of the groove. If this happens, remove the ring and bearing, and install a new one.

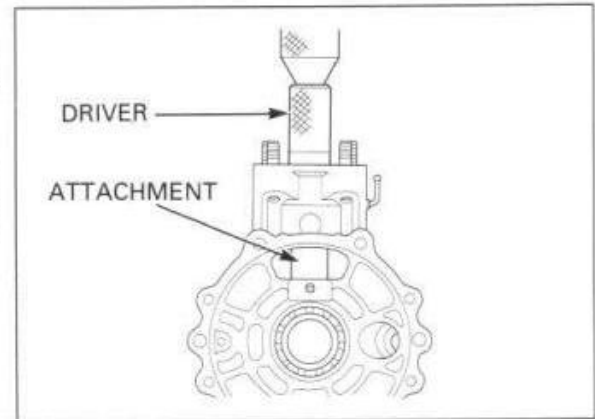

Make sure that the stopper ring is securely set in the groove of the final gear case.

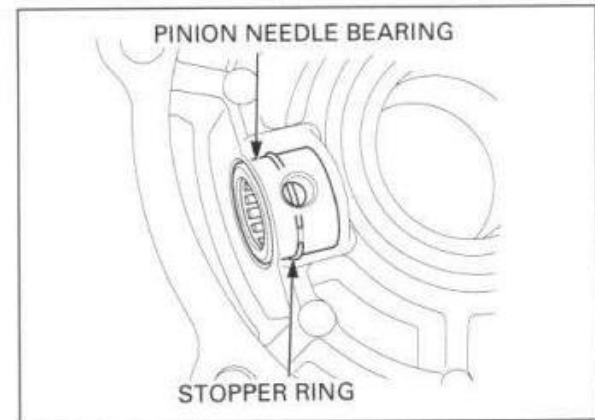

**CASE BEARING REPLACEMENT**

Remove the oil seal.  
 Drive the ring gear bearing out of the case.

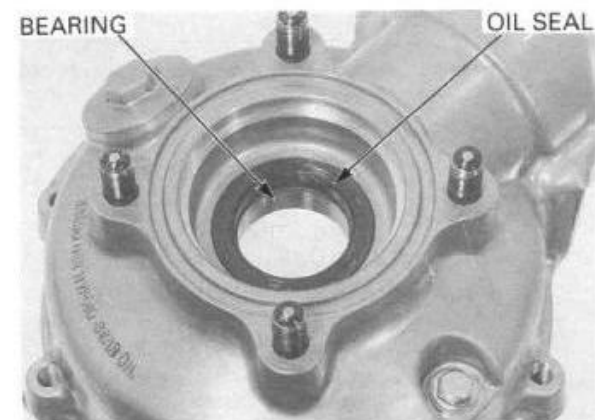

---

MEMO

The battery is normal if the specified regulated voltage is displayed on the multimeter.

**NOTE:**

The speed at which the voltage starts to rise cannot be checked as it varies with the temperature and loads of the generator.

A frequently discharged battery is an indication that it is deteriorated even if it proves normal in the regulated voltage inspection.

The charging circuit may be abnormal if any of the following symptoms is encountered.

- ① Voltage does not rise to regulated voltage:
  - Open or short circuit in the charging system wire harness or poorly connected connector.
  - Open or short of the alternator.
  - Faulty regulator/rectifier.
- ② Regulated voltage is too high:
  - Poorly grounded voltage regulator/rectifier.
  - Faulty battery.
  - Faulty regulator/rectifier.

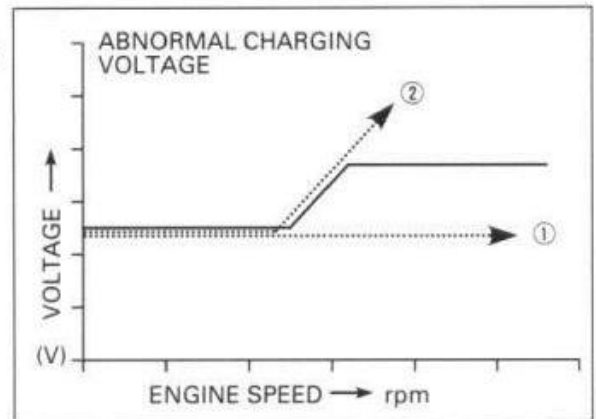
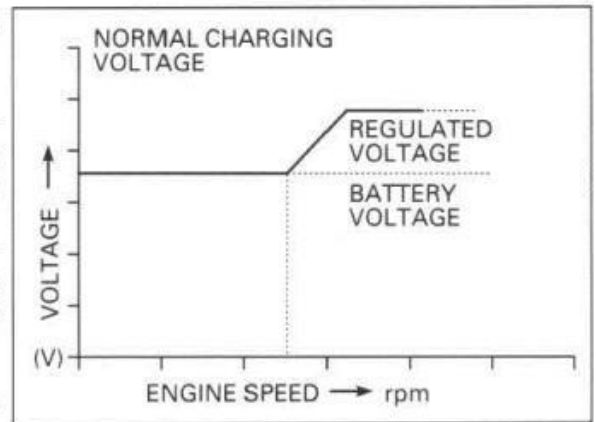

## CURRENT LEAKAGE INSPECTION

Turn the ignition switch off and disconnect the negative battery cable from the battery. Connect the ammeter (+) probe to the ground cable and the ammeter (-) probe to the battery (-) terminal. With the ignition switch off, check for current leakage.

**NOTE:**

- When measuring current using a tester, set it to a high range, and then bring the range down to an appropriate level. Current flow higher than the range selected may blow out the fuse in the tester.
- While measuring current, do not turn the ignition on. A sudden surge of current may blow out the fuse in the tester.

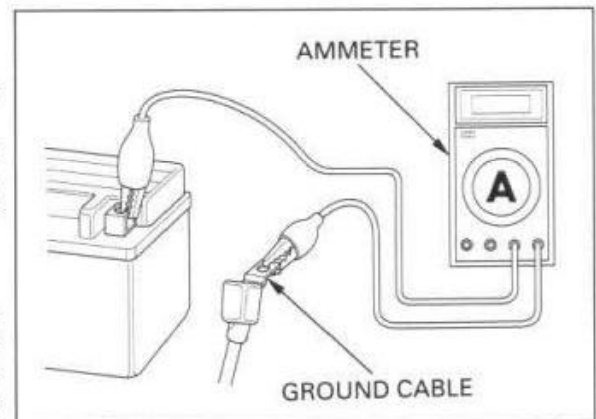

**SPECIFIED CURRENT LEAKAGE: 5 mA max.**

If current leakage exceeds the specified value, a shorted circuit is likely.

Locate the short by disconnecting connections one by one and measuring the current.

## IGNITION COIL

### REMOVAL/INSTALLATION

Remove the fuel tank and heat guard (page 5-20).

Disconnect the spark plug cap from the plug.  
Release the spark plug wire from the clamp.  
Disconnect the primary wires from the ignition coil.  
Remove the ignition coil.

Installation is in the reverse order of removal.

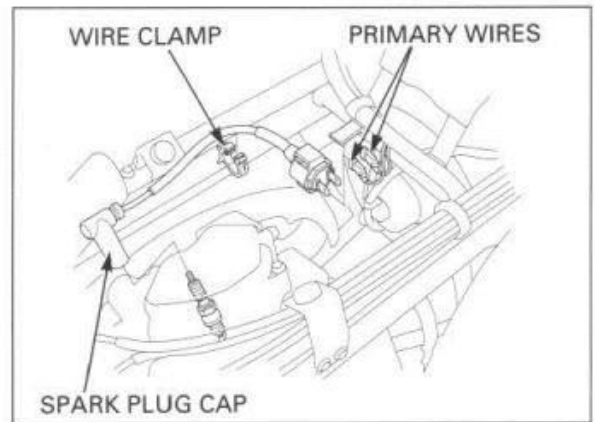

## IGNITION PULSE GENERATOR

### REMOVAL

Remove the alternator cover (page 10-6)

Disconnect the ignition pulse generator connector and release the wire from the ignition pulse generator body groove.  
Remove the socket bolts and ignition pulse generator.

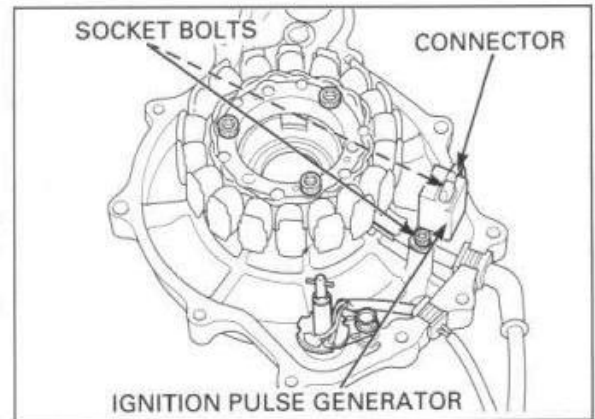

### INSTALLATION

Install the ignition pulse generator onto the alternator cover.

Apply a locking agent to the ignition pulse generator socket bolt threads.  
Install and tighten the socket bolts to the specified torque.

**TORQUE: 6 N·m (0.6 kgf·m , 4.3 lbf·ft)**

Apply sealant to the ignition pulse generator grommet.

Install the ignition pulse generator grommet into the groove of the body securely.

Install the alternator cover (page 10-14).

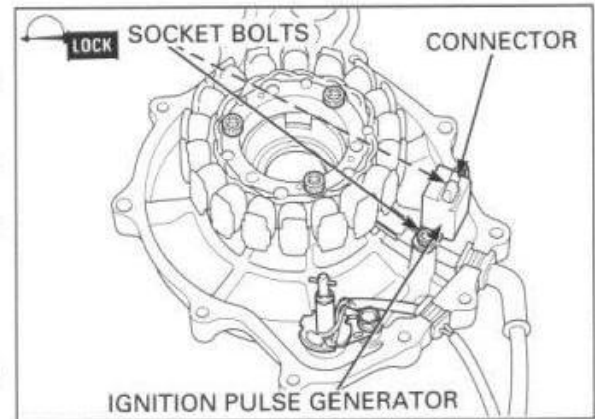

**INSTALLATION**

Install the starter motor with the two mounting bolts.  
Connect the starter cable to the motor.

Install the right engine side cover (page 6-10).

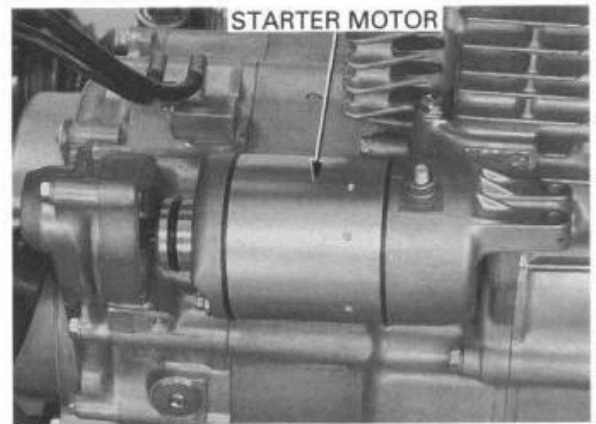
**STARTER RELAY SWITCH****OPERATION INSPECTION**

Remove the seat and battery holder bracket.

Depress the starter switch button with the ignition switch ON.

The coil is normal if the starter relay switch clicks.

**VOLTAGE INSPECTION**

If the switch "CLICK" is not heard, disconnect the relay connector.

Measure the voltage between the Yellow/Red (+) and Light green (-) wire terminals of the wire harness side.

The battery voltage should be indicated when the starter switch button is depressed with the ignition switch ON and the transmission in neutral.

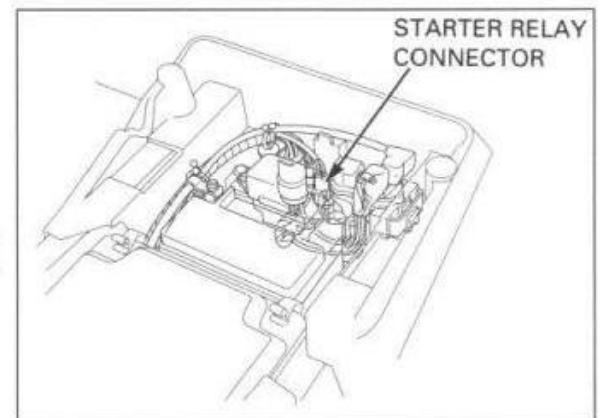
**CONTINUITY INSPECTION**

Connect an ohmmeter to the starter relay switch large terminals.

Connect a fully charged 12V battery to the starter relay switch connector terminals (Yellow/Red and Light green).

Check for continuity between the starter relay switch terminals.

There should be continuity while 12V battery is connected to the starter relay switch connector terminals and there should be no continuity when the battery is disconnected.

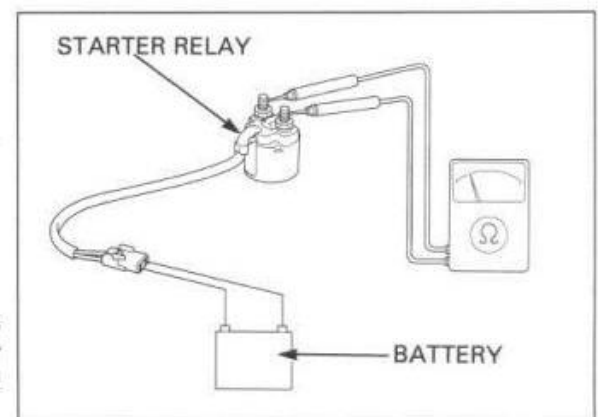

Install the assist headlight and tighten the two bolts loosely.

Align the slit on the lower assist headlight case and line on the lens.

Hold the assist headlight and tighten the bolts securely.

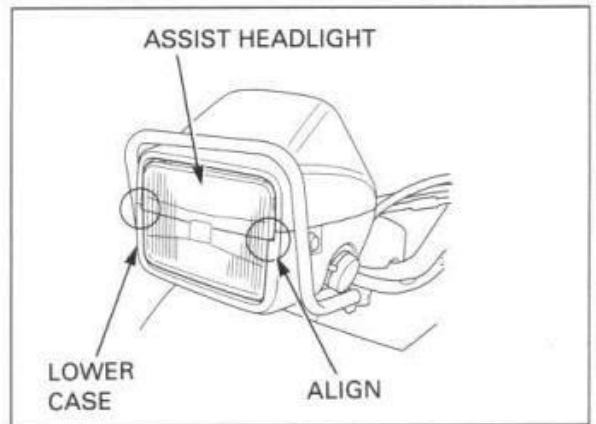

Install assist headlight upper case and tighten the screw.

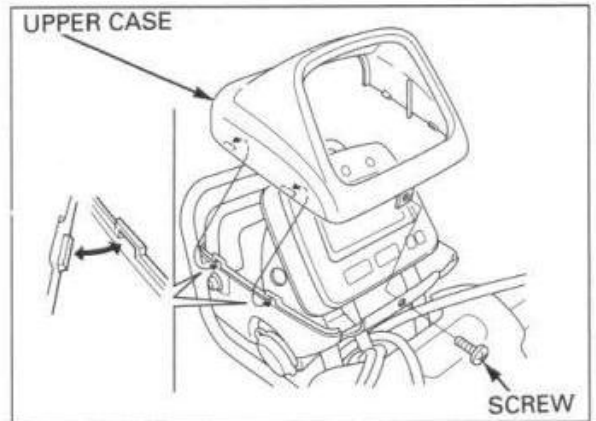

## TAILLIGHT

### BULB REPLACEMENT

Turn the bulb socket counterclockwise and remove the bulb socket from the taillight case.

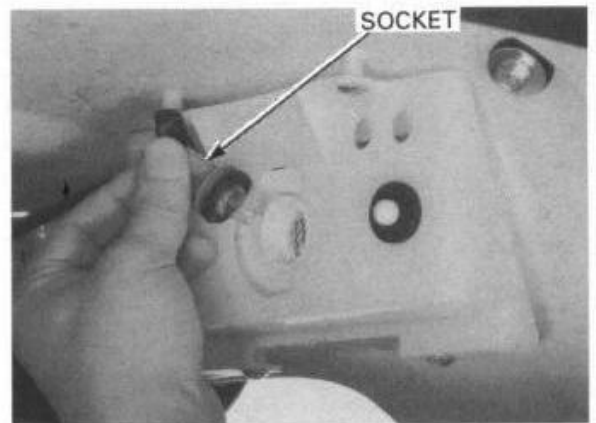

Remove the bulb from the socket and replace it with a new one.

Install the bulb in the reverse order of removal.

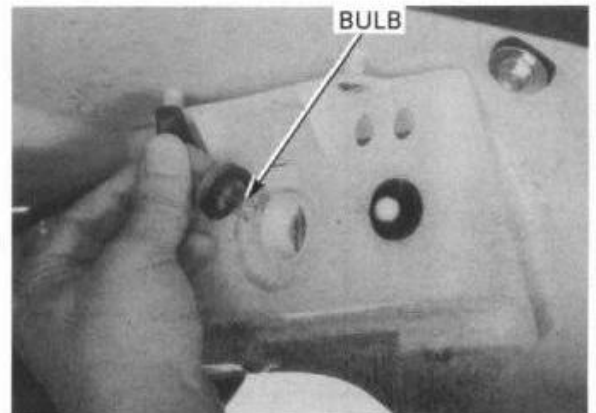

---

MEMO

**ELECTRIC SHIFT MALFUNCTION DURING VEHICLE OPERATION**

- Inspect the following before diagnosing the system.
  - The engine run normally
  - Speedometer operates normally

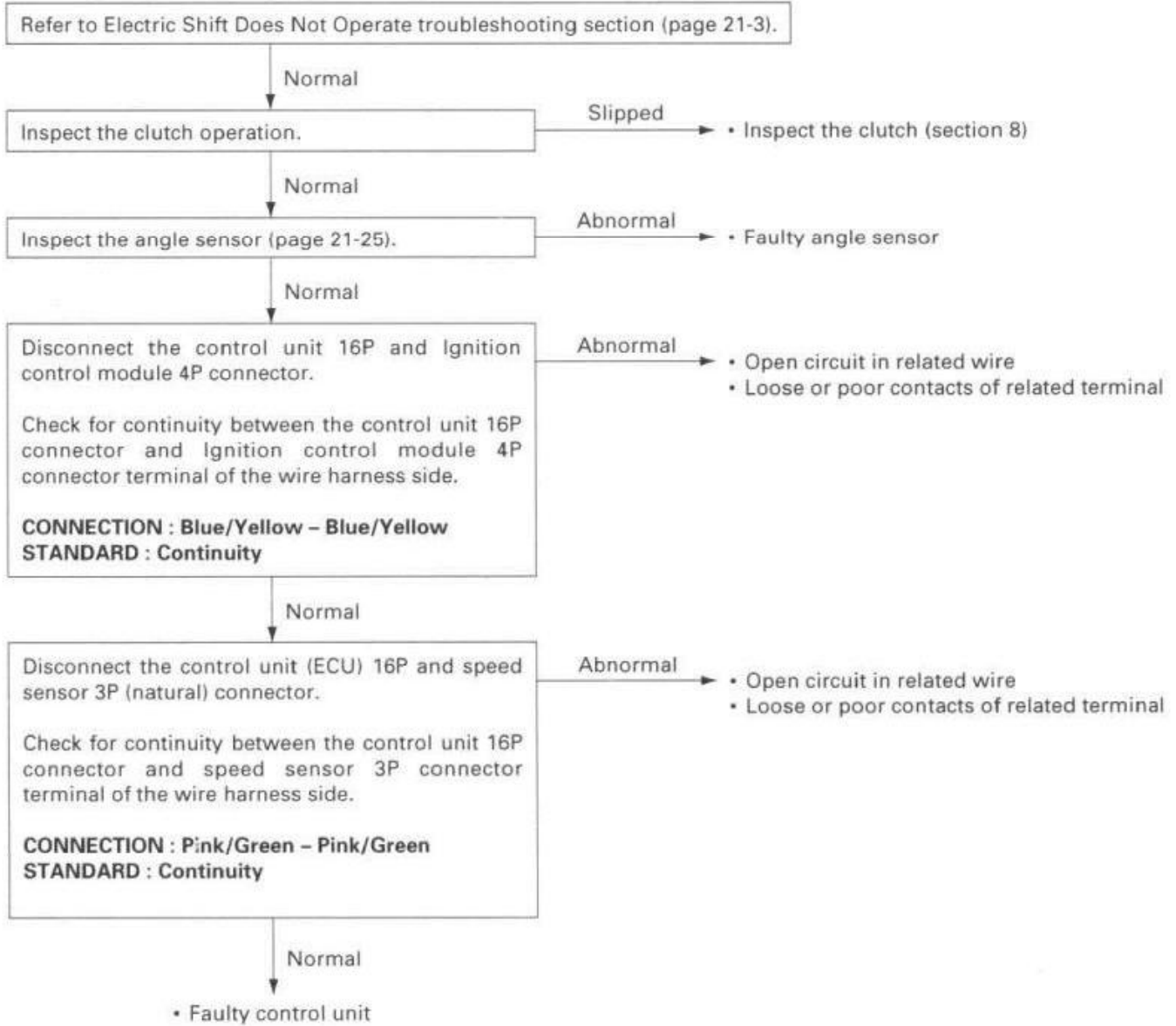

**Problem Code 3, 8, 9: Angle Sensor System**

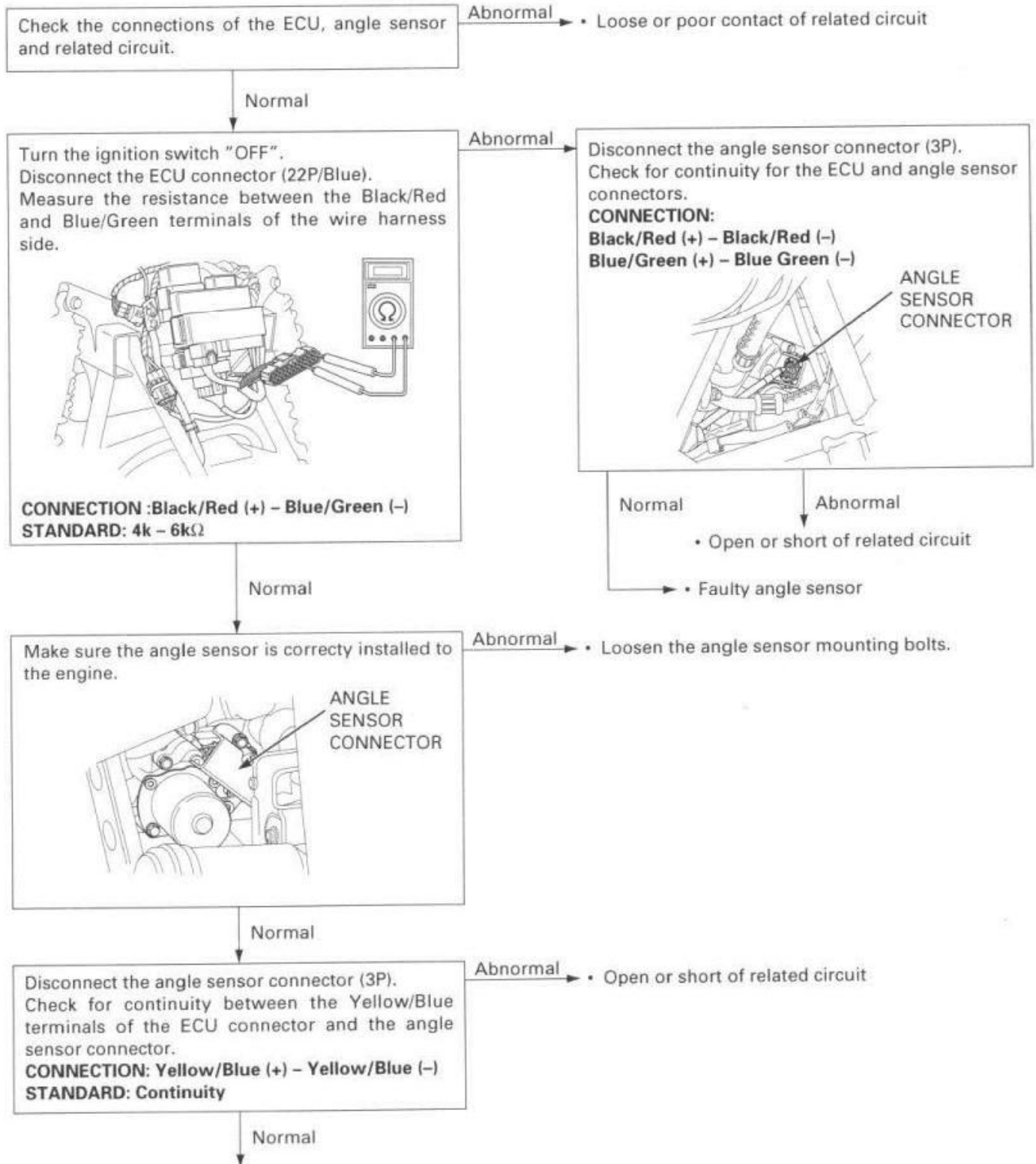

Thoroughly clean and apply the specified grease to the reduction gear contact area as shown.

**RECOMMENDED GREASE :**  
**UNIREX N2 GREASE (ESSO) or**  
**UNIREX N3 GREASE (ESSO) or equivalent**

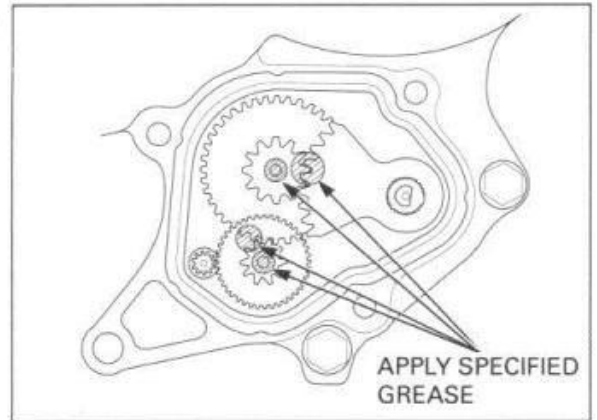

Install the reduction gears (41T/10T and 40T/12T).  
Install the reduction gear (7T) by aligning the punch marks on the reduction gear (7T) and gear shift spindle.

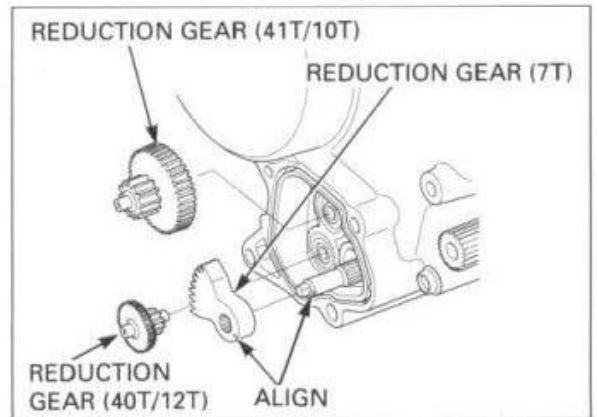

Install a new O-ring and dowel pin.  
Install the control motor and tighten the bolts.

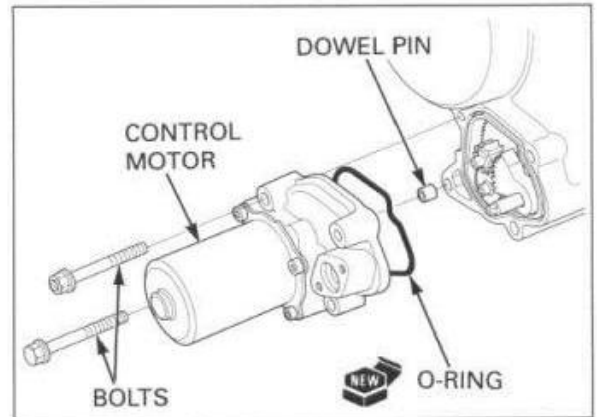

Connect the control motor 2P connector.  
Install the angle sensor (page 21-27).

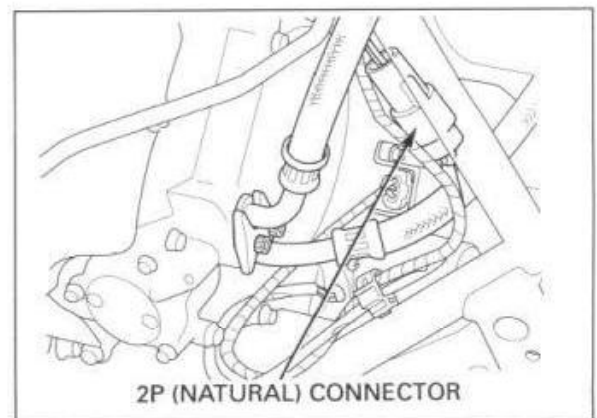

### 4WD Indicator Problem Code 4: FCC Unit System Voltage

- Inspect the following before diagnosing the system.
  - Make sure the battery is fully charged and in good condition.
  - Engine idle speed

Check the connections of the FCC unit, fuse box, battery and related circuit.

Abnormal → • Loose or poor connections in related circuit

Normal

Turn the ignition switch "ON" and check the number of times the 4WD indicator blinks after 30 seconds.

No blinks → • No problem (temporary failure)

four time blinks

Turn the ignition switch "OFF".  
Disconnect the FCC unit connector.  
With the ignition switch "ON", measure the voltage between the Red/White and Green connector terminals of the wire harness side.

Abnormal → • Short or open circuit between battery and FCC unit  
• If the related wire is OK, check the charging system (section 17)

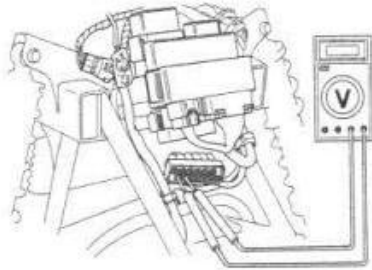

**CONNECTION: Red/White (+) – Green (-)**  
**STANDARD: 11 – 16 V**

Normal

Replace the FCC unit with a new one and troubleshoot again

# WIRING DIAGRAM

## TRX450FE (After '01)

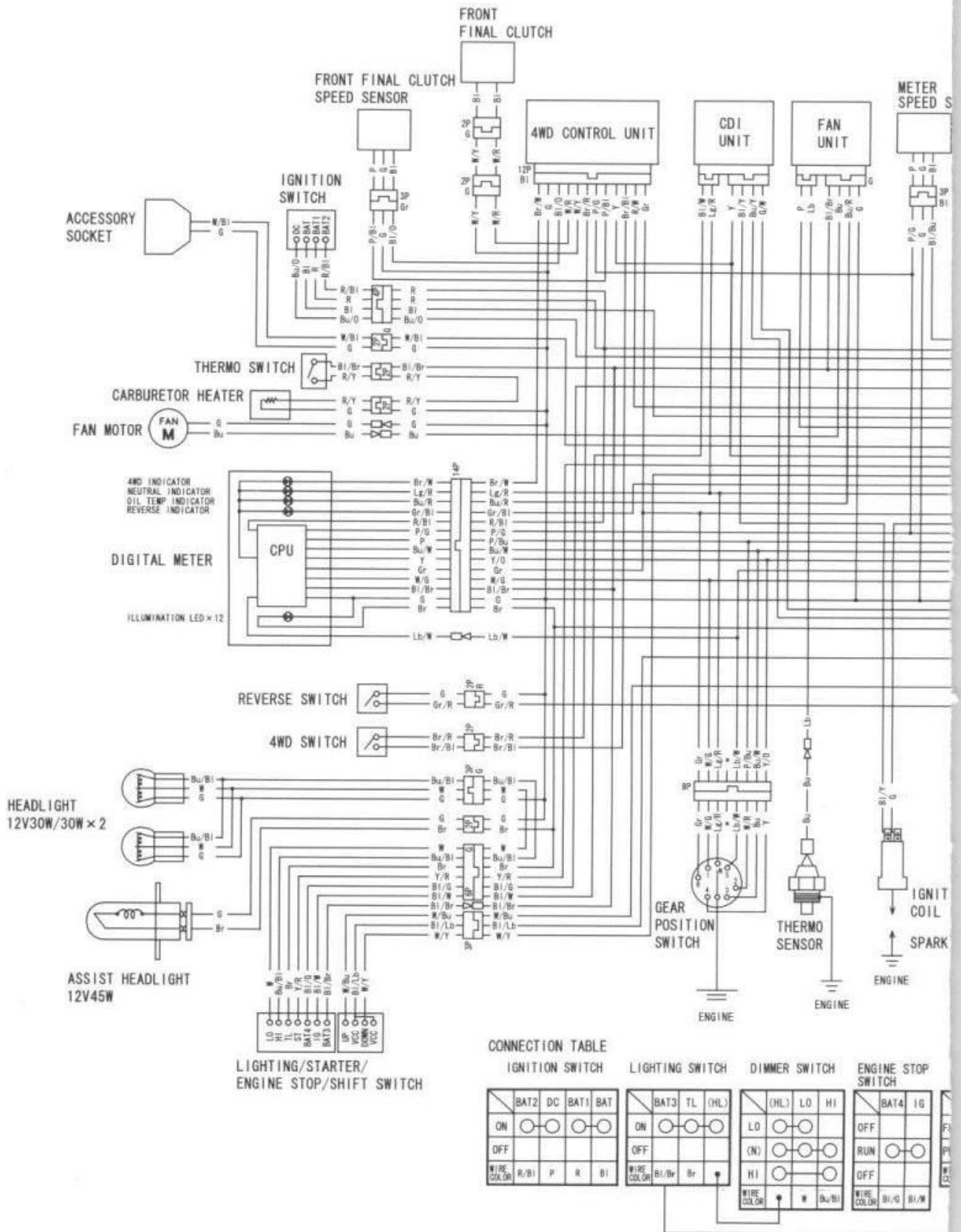

CLICK HERE TO **DOWNLOAD** THE COMPLETE MANUAL

- Thank you very much for reading the preview of the manual.
- You can download the complete manual from: [www.heydownloads.com](http://www.heydownloads.com) by clicking the link below



- Please note: If there is no response to CLICKING the link, please download this PDF first and then click on it.

CLICK HERE TO **DOWNLOAD** THE COMPLETE MANUAL