

## CHAPTER ONE

# GENERAL INFORMATION

This detailed and comprehensive manual covers 1986-2003 XL/XLH Sportster models. The text provides complete information on maintenance, tune-up, repair and overhaul. Hundreds of photos and drawings guide the reader through every job.

A shop manual is a reference tool and as in all Service manuals, the chapters are thumb tabbed for easy reference. Important items are indexed at the end of the book. All procedures, tables and figures are designed for the reader who may be working on the motorcycle for the first time. Frequently used specifications and capacities from individual chapters are summarized in the *Quick Reference Data* at the front of this manual.

### MANUAL ORGANIZATION

All dimensions and capacities are expressed in U.S. standard and metric units of measurement.

Specifications, when applicable, are listed in the tables at the end of each chapter.

This chapter covers shop safety, tool use, service fundamentals and shop supplies. **Tables 1-12** at the end of the chapter include the following:

1. Model designations.

2. General motorcycle dimensions.
3. Motorcycle weight.
4. Gross vehicle weight.
5. Fuel tank capacity.
6. General torque recommendations.
7. Conversion formulas.
8. Technical abbreviations.
9. U.S. standard tap and drill sizes.
10. Metric tap and drill sizes.
11. Decimal and metric equivalents.
12. Special tools.

Chapter Two provides methods for quick and accurate diagnosis of problems. Troubleshooting procedures present typical symptoms and logical methods to pinpoint and repair the problem.

Chapter Three explains all routine maintenance necessary to keep the motorcycle running well. Chapter Three also includes recommended tune-up procedures, eliminating the need to constantly consult the chapters on the various assemblies.

Subsequent chapters describe specific systems such as engine, primary drive and clutch, transmission, emissions, fuel and exhaust systems, the electrical system, suspension, brakes and body. Each disassembly, repair and assembly procedure is discussed in step-by-step form.

CLICK HERE TO **DOWNLOAD** THE COMPLETE MANUAL

- Thank you very much for reading the preview of the manual.
- You can download the complete manual from: [www.heydownloads.com](http://www.heydownloads.com) by clicking the link below



- Please note: If there is no response to CLICKING the link, please download this PDF first and then click on it.

CLICK HERE TO **DOWNLOAD** THE COMPLETE MANUAL

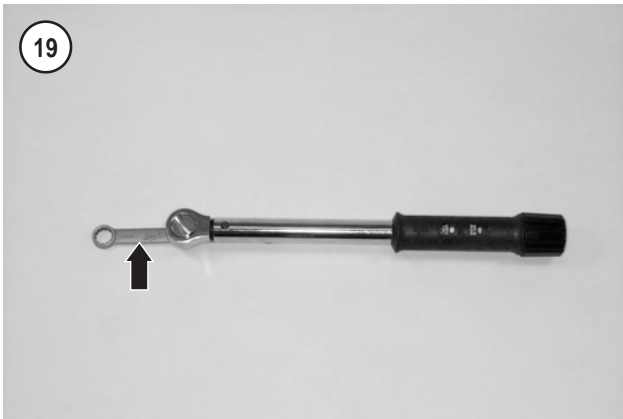

ods for reading the torque value. The drive size indicates the size of the square drive that accepts the socket, adapter or extension. Common methods for reading the torque value are the reflecting beam, the dial indicator and the audible click.

When choosing a torque wrench, consider the torque range, drive size and accuracy. The torque specifications in this manual provide an indication of the range required.

A torque wrench is a precision tool that must be properly cared for to remain accurate. Store torque wrenches in cases or separate padded drawers within a toolbox. Follow the manufacturer’s instructions for their care and calibration.

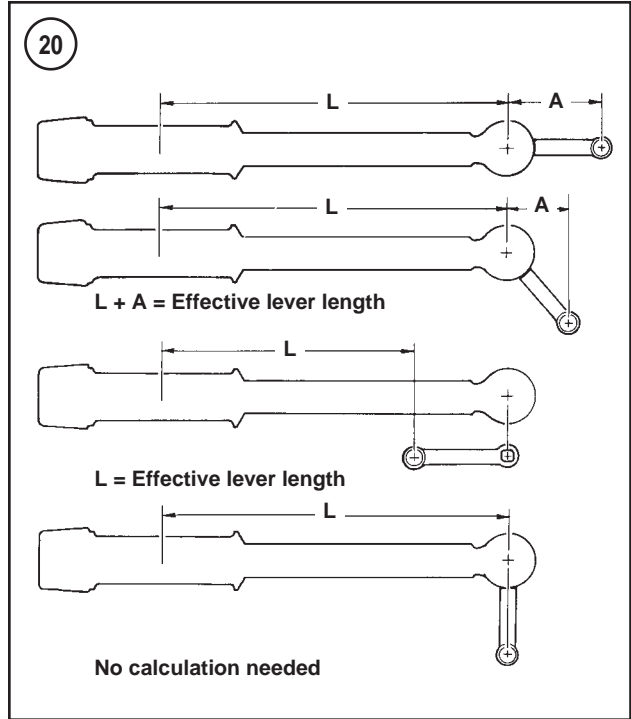

**Torque Adapters**

Torque adapters or extensions extend or reduce the reach of a torque wrench. The torque adapter shown in **Figure 19** is used to tighten a fastener that cannot be reached due to the size of the torque wrench head, drive, and socket. If a torque adapter changes the effective lever length (**Figure 20**), the torque reading on the wrench will not equal the actual torque applied to the fastener. It is necessary to recalibrate the torque setting on the wrench to compensate for the change of lever length. When a torque adapter is used at a right angle to the drive head, calibration is not required, since the effective length has not changed.

To recalculate a torque reading when using a torque adapter, use the following formula, and refer to **Figure 20**.

$$TW = \frac{TA \times L}{L + A}$$

TW is the torque setting or dial reading on the wrench.

TA is the torque specification and the actual amount of torque that will be applied to the fastener.

A is the amount that the adapter increases (or in some cases reduces) the effective lever length as measured along the centerline of the torque wrench.

L is the lever length of the wrench as measured from the center of the drive to the center of the grip.

The effective length is the sum of L and A.

Example:

TA = 20 ft.-lb.

A = 3 in.

L = 14 in.

$$TW = \frac{20 \times 14}{14 + 3} = \frac{280}{17} = 16.5 \text{ ft.-lb.}$$

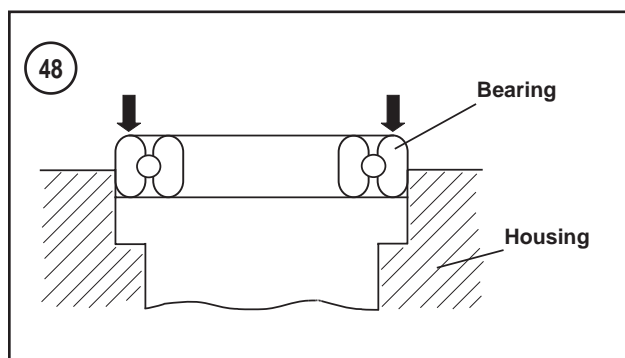
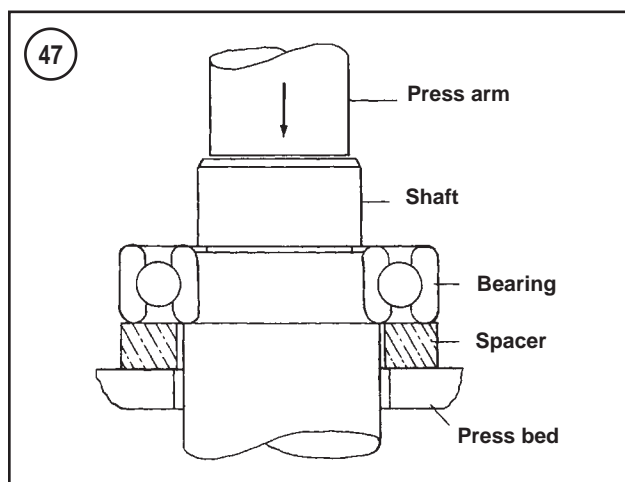
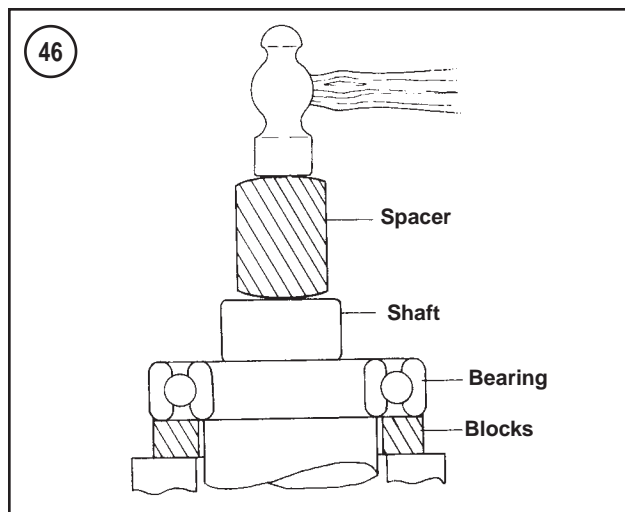

bearing is damaged, replace it immediately. When installing a new bearing, take care to prevent damaging it. Bearing replacement procedures are included in the individual chapters where applicable; however, use the following sections as a guideline.

#### NOTE

*Unless otherwise specified, install bearings with the manufacturer's mark or number facing out.*

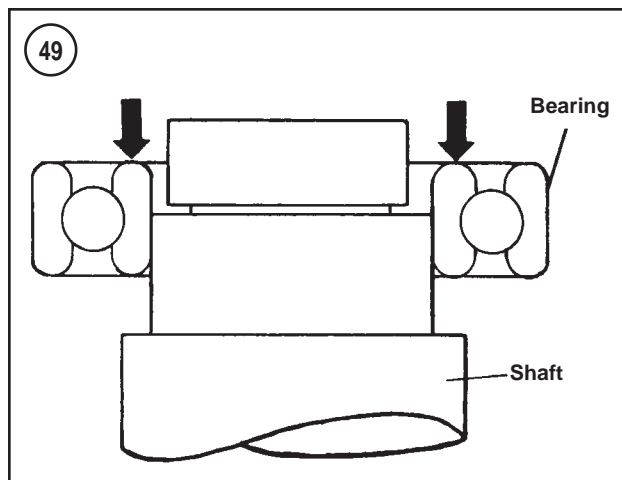

#### Removal

While bearings are normally removed only when damaged, there may be times when it is necessary to remove a bearing that is in good condition. However, improper bearing removal will damage the bearing and maybe the shaft or case half. Note the following when removing bearings.

1. When using a puller to remove a bearing from a shaft, take care that the shaft is not damaged. Always place a piece of metal between the end of the shaft and the puller screw. In addition, place the puller arms next to the inner bearing race (Figure 45).
2. When using a hammer to remove a bearing from a shaft, do not strike the hammer directly against the shaft. Instead, use a brass or aluminum spacer between the hammer and shaft (Figure 46) and make sure to support both bearing races with wooden blocks as shown.
3. The ideal method of bearing removal is with a hydraulic press. Note the following when using a press:
  - a. Always support the inner and outer bearing races with a suitable size wooden or aluminum spacer (Figure 47). If only the outer race is supported, pressure applied against the balls and/or the inner race will damage them.
  - b. Always make sure the press arm (Figure 47) aligns with the center of the shaft. If the arm is not centered, it may damage the bearing and/or shaft.
  - c. The moment the shaft is free of the bearing, it will drop to the floor. Secure or hold the shaft to prevent it from falling.

#### Installation

1. When installing a bearing in a housing, apply pressure to the *outer* bearing race (Figure 48). When installing a bearing on a shaft, apply pressure to the *inner* bearing race (Figure 49).
2. When installing a bearing as described in Step 1, some type of driver is required. Never strike the bearing directly with a hammer or the bearing will be damaged. When in-

Table 12 SPECIAL TOOLS (continued)

<b>Tool description</b>	<b>Part No.</b>	<b>Manufacturer</b>
Pinion gear locking tool	2234	JIMS
Pinion gear oil seal	See text	
Retaining ring tool	1710	JIMS
Rocker arm bushing reamer	HD-94804-57	H-D
Scanalyzer	HD-41325	H-D
Shock absorber spring compressor	HD-97010-52A	H-D
Speedometer tester	HD-41354	H-D
Sprocket locking link	HD-38362	H-D
Sprocket shaft bearing cone installer	HD-37047A/HD-42759	H-D
Sprocket shaft bearing race	2246/94547-80B	JIMS
Steering head bearing race installation tool	HD-39302	H-D
Terminal pick	HD-39621-28	H-D
Terminal tool	HD-97364-71	H-D
Transmission cross plate	HD-35316-91	H-D
Transmission gear spacing tool	HD-35820	H-D
Vacuum pump	HD-23738	H-D
Valve guide brush	HD-34751	H-D
Valve guide driver handle/remover	HD-34740	H-D
Valve guide hone	HD-34723	H-D
Valve guide installation tool	HD-34731A	H-D
Valve guide reamer	HD-39932/HD-39932-CAR	H-D

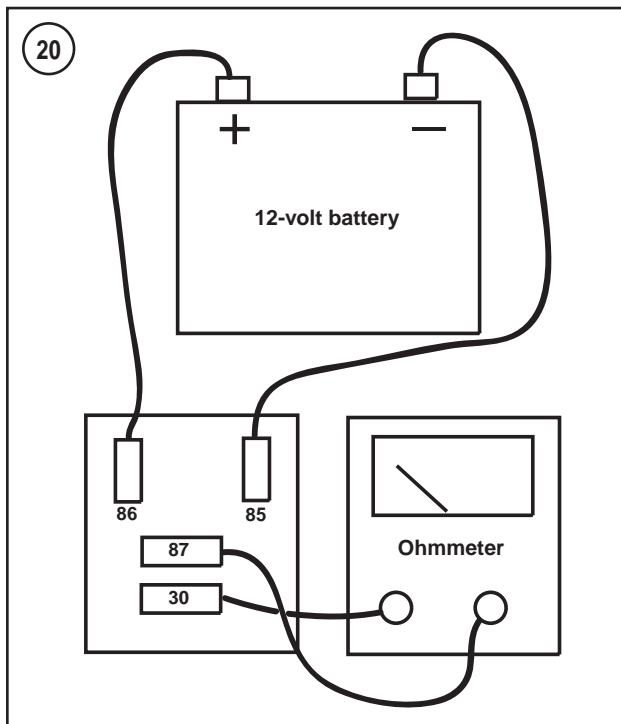
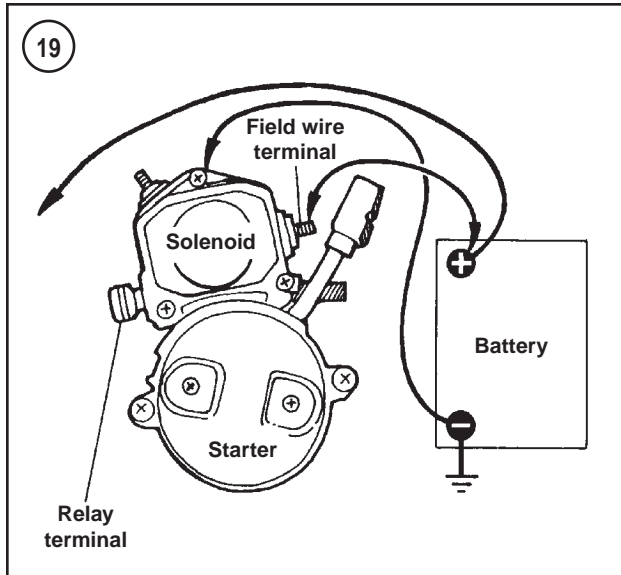

2. Connect an ohmmeter and 12-volt battery between the relay terminals shown in **Figure 20**. This setup will energize the relay for testing.
3. Check for continuity through the relay contacts using an ohmmeter while the relay coil is energized. The correct reading is 0 ohm. If resistance is excessive or if there is no continuity, replace the relay.
4. If the starter relay passes this test, reinstall the relay.

## CHARGING SYSTEM

The charging system consists of the battery, alternator and a solid state voltage regulator/rectifier.

The alternator generates alternating current (AC) which the rectifier converts to direct current (DC). The regulator maintains the voltage to the battery and load (lights, ignition and accessories) at a constant voltage despite variations in engine speed and load.

A malfunction in the charging system generally causes the battery to remain undercharged.

### Service Precautions

Before servicing the charging system, observe the following precautions to prevent damage to any charging system component:

1. Never reverse battery connections.
2. Do not short across any connection.
3. Never start the engine with the alternator disconnected from the voltage regulator/rectifier unless instructed to do so during testing.
4. Never attempt to start or run the engine with the battery disconnected.
5. Never attempt to use a high-output battery charger to help start the engine.
6. Before charging the battery, remove it from the motorcycle as described in Chapter Twelve.
7. Never disconnect the voltage regulator/rectifier connector with the engine running. The voltage regulator/rectifier (**Figure 21**) is mounted on the front frame cross member.
8. Do not mount the voltage regulator/rectifier unit in another location.
9. Make sure the negative battery terminal is connected to the terminal on the engine.

### Troubleshooting Sequence

If the battery is discharged, perform the following procedures as listed:

1. Test the battery as described in Chapter Twelve. Charge the battery if necessary. If the battery will hold a charge while riding, perform the *Charging System Output Test* as described in this section.
2. If the charging system output is within specification, determine the total amount of current demand by the electrical



### Ignition Module Harness Resistance Test (1991-1997 Models)

Refer to **Figure 43**

1. Turn the ignition stop switch (**Figure 42**) to the off position.
2. Disconnect the 7-prong ignition module electrical connector.
3. Disconnect the sensor plate 3-prong electrical connector.
4. On 1991-1993 models connect the positive ohmmeter lead to the No. 4 ignition module connector on the wiring harness side, not on the module side. On 1994-1997 models connect the positive ohmmeter lead to pin No. 7 on the ignition module connector on the wiring harness side, not on the module side. Connect the negative ohmmeter lead to a good engine ground. Wiggle the wiring harness and read the resistance indicated on the ohmmeter. It should be 0-1 ohm. Note the following:
  - a. If the resistance reading is correct, perform Step 5.
  - b. If a high resistance reading is obtained, check for dirty or loose-fitting terminals or a bare or damaged wire; clean and repair as required.
5. Connect the positive ohmmeter lead to the No. 1 ignition module connector socket on the wiring harness side, not on the module side. Connect the negative ohmmeter lead to a good ground. Wiggle the wiring harness and read the ohmmeter scale. It should be infinity (high resistance). Note the following:
  - a. If the reading is infinity, perform Step 6.
  - b. If the meter shows a resistance reading, the wire is shorting to ground. Repair the wire and retest.
  - c. On 1991-1993 models, repeat this test for the following ignition module connector sockets: No. 2, 3, 5, 6 and 7.
  - d. On 1994-1997 models, repeat this test for the following ignition module connector sockets: No. 2, 3, 4, 5 and 6.
6. Check each of the ignition module socket wires (except No. 4 on 1991-1993 models or No. 7 on 1994-1997 models) for continuity with an ohmmeter set on the appropriate scale. The reading for each wire should be 0-1 ohm. An infinite reading indicates that there is an open in the wire; check for a dirty, loose-fitting or a damaged connector or wire. Repair as needed and retest.

### IGNITION SYSTEM (ALL 1998-2003 MODELS [EXCEPT 1200S MODELS])

Review *Precautions* and *Troubleshooting Preparation in Ignition System (1986-1997 Models)* in this chapter.

Refer to the wiring diagrams at the end of this manual.

#### Tools

Troubleshooting the ignition system requires a breakout box (part No. HD-42682) as well as the breakout box harness adapters (part No. HD-42962). When connected inline in the ignition system, the breakout box provides test points for checking a live circuit.

If the breakout box is not available, fabricate a test harness (**Figure 44**) from 12 lengths of 16-gauge wire, a male Deutsch (6-pin) connector and two female Deutsch connectors (6-socket). Wire the No. 1 pin on the male connector to the No. 1 socket on each female connector. No. 2 pin to No. 2 socket, etc.

During testing, connect the harness between the two ends of the ignition control module connector (**Figure 45**) when instructed to install the test harness. Probe the second female connector at the indicated test points.

Troubleshooting the ignition system also requires the Harley-Davidson harness test kit (part No. HD-41404). Different-sized terminals are used in the connectors on a Sportster. This kit is equipped with different-sized probes for checking the voltage and resistance of the various-sized terminals without damaging the wire insulation.

#### Troubleshooting Tests

1. Perform the procedures described in *Troubleshooting Preparation* in this chapter.
2. Perform the spark test described in *Starting the engine* in this chapter.
  - a. If there is good spark, the problem is not in the ignition system. Check the fuel system.
  - b. If there is no spark or only a weak one, recheck with a new spark plug(s). If the condition remains the same with new spark plugs and if all external wiring connections are good, the problem is most likely in the ignition system; perform the *Ignition Test (Continuous or No Spark at Spark Plug)* described in this section.

#### Ignition Test (Continuous or No Spark at Spark Plug)

1. To perform this test, the battery must be fully charged. Check the battery as described in Chapter Twelve.
2. Make sure the ignition module ground is good.

#### NOTE

*When performing the following test procedures, it will be necessary to fabricate a test*

61

## SYMPTOMS

Symptom	Possible cause	Action
Hard to Start	Battery discharged	Troubleshoot the charging system as described in this chapter
	Spark plugs Ignition coil Plug wires Valve sticking Water or dirt in the fuel system	Perform the procedure in Figure 67 Perform the procedure in Figure 67 Perform the procedure in Figure 67 Refer to the Chapter Four Drain the fuel system and refill with fresh fuel
Engine hesitates, stumbles, surges, misfires or is sluggish	Manifold leak	Spray water around the intake manifold seals while the engine idles. If idle speed changes, replace the seals.
	MAP sensor is not operating properly	Check the vacuum hose connection and perform the procedure in Figure 68
	Water or dirt in the fuel system	Drain the fuel system and refill with fresh fuel
	Spark plug EVAP hose disconnected from carburetor (California models) Throttle plates not opening fully	Perform the procedure in Figure 68 Reconnect Adjust the throttle cable as described in Chapter Three
Engine exhaust emits black smoke or spark plugs are fouled	Clogged air filter MAP sensor is not operating properly	Replace the air filter (Chapter Three) Check the vacuum hose connection and perform the procedure in Figure 68

**Fuel level system**

The fuel level system is shown in **Figure 77** or **Figure 78**. Proper carburetor operation depends on a constant and correct carburetor fuel level. As fuel is drawn from the float bowl during engine operation, the float level in the bowl drops. As the float drops, the fuel valve moves from its seat and allows fuel to flow through the seat into the float bowl. Fuel entering the float bowl causes the float to rise and push against the fuel valve. When the fuel level reaches a predetermined level, the fuel valve is pushed against the seat to prevent the float bowl from overflowing.

If the fuel valve fails to close, the engine will run rich or flood with fuel. Symptoms of this problem are rough running, excessive black smoke and poor acceleration. This condition will sometimes clear up when the engine is run at wide-open throttle and the fuel is being drawn into the engine before the float bowl can overflow. However, as the engine speed is reduced, the rich running condition returns.

Several things can cause fuel overflow. In most instances, a small piece of dirt is trapped between the fuel valve and seat, or the float level is incorrect. If fuel is flowing out of the overflow tube connected to the bottom of the float bowl, the fuel valve inside the carburetor is being held open. First check the position of the fuel shutoff valve lever (A, **Figure 79**). Turn the fuel shutoff valve lever off. Then lightly tap on the carburetor float bowl and turn the fuel shutoff valve lever on. If the fuel flow stops running out of

the overflow tube, whatever was holding the fuel valve off of its seat has been dislodged. If fuel continues to flow from the overflow tube, remove and service the carburetor. See Chapter Ten or Chapter Eleven.

*NOTE*

*Fuel will not flow from the vacuum-operated fuel shutoff valve on 1995-2003 models until the engine is running.*

**Starting enrichment (choke) system**

A cold engine requires a rich mixture to start and run properly. On all models, a cable-actuated starter enrichment valve is used for cold starting.

If the engine is difficult to start when cold, check the starting enrichment (choke) cable adjustment described in Chapter Three.

**Accelerator pump system**

During sudden acceleration, the diaphragm type accelerator pump system (**Figure 80** or **Figure 81**) provides additional fuel to the engine. Without this system, the carburetor would not be able to provide a sufficient amount of fuel.

The system consists of a spring-loaded neoprene diaphragm that is compressed by the pump lever during sudden

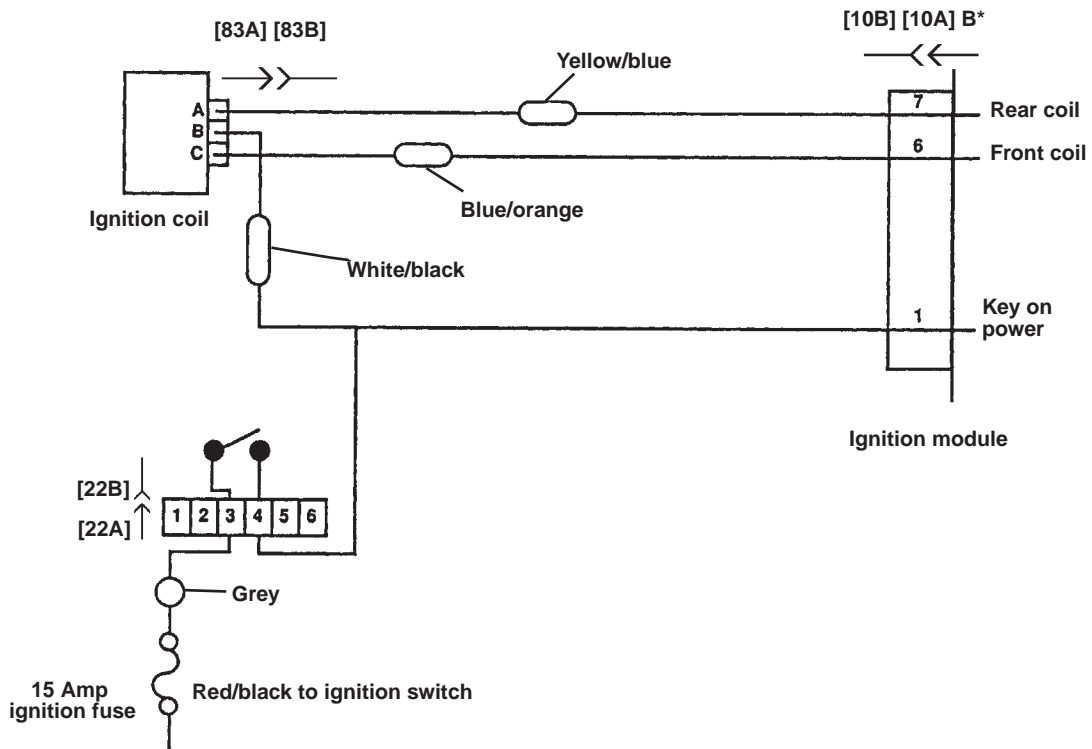

**\*Note:** Before replacing the ignition module, confirm it is defective by taking the motorcycle to a dealership. Further testing requires the Scanalyzer.

\*Before replacing the ignition module, confirm it is defective by taking the motorcycle to a dealership. Further testing requires the Scanalyzer.

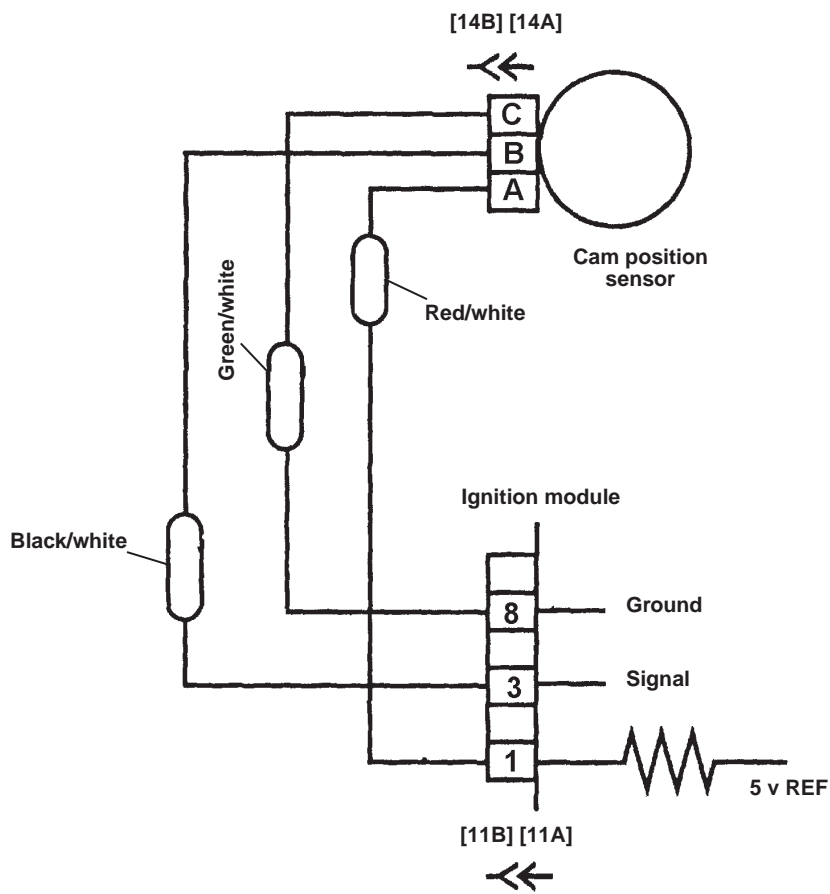



### Jumping Out of Gear

1. Incorrect shifter pawl adjuster.
2. Worn or damaged shifter parts.
3. Bent shift forks.
4. Severely worn or damaged gears.

### Difficult Shifting

1. Worn or damaged shift forks.
2. Loose or damaged detent plate.
3. Worn or damaged shift shaft assembly.
4. Worn or damaged detent arm.
5. Worn shift fork drum groove(s).
6. Loose, worn or damaged shifter fork pin(s).
7. Damaged shift shaft splines.

### Excessive Gear Noise

1. Worn or damaged bearings.
2. Worn or damaged gears.
3. Excessive gear backlash.

## ELECTRICAL TESTING

This section describes typical test equipment and how to troubleshoot with it.

Never assume anything and do not overlook the obvious, such as a blown fuse or an electrical connector that has separated. Test the simplest and most obvious items first and try to make tests at easily accessible points on the motorcycle. Make sure to troubleshoot systematically.

Refer to the color wiring diagrams at the end of the manual for component and connector identification. Use the wiring diagrams to determine how the circuit should work by tracing the current paths from the power source through the circuit components to ground. Also check any circuits that share the same fuse, ground or switch. If the other circuits work properly and the shared wiring is good, the cause must be in the wiring used only by the suspect circuit. If all related circuits are faulty at the same time, the probable cause is a poor ground connection or a blown fuse(s).

### Preliminary Checks and Precautions

Before starting any electrical troubleshooting, perform the following:

1. Inspect the fuse for the suspected circuit, and replace it if blown. Refer to *Circuit Breakers* and *Fuses* in Chapter Twelve.
2. Inspect the battery (Chapter Twelve). Make sure it is fully charged and the battery leads are clean and securely attached to the battery terminals.
3. Electrical connectors are often the cause of electrical system problems. Inspect the connectors as follows:
  - a. Disconnect each electrical connector in the suspect circuit and make sure there are no bent terminals in the electrical connector. A bent terminal will not connect to its mate, causing an open circuit.
  - b. Make sure the terminals are pushed all the way into the connector. If not, carefully push them in with a narrow blade screwdriver.
  - c. Check the wires where they attach to the terminals for damage.
  - d. Make sure each terminal is clean and free of corrosion. Clean them, if necessary, and pack the connectors with dielectric grease.
  - e. Push the connector halves together. Make sure the connectors are fully engaged and locked together.
  - f. Never pull the wires when disconnecting a connector. Pull only on the connector housing.
4. Never use a self-powered test light on circuits that contain solid-state devices. The solid-state devices may be damaged.

### Intermittent Problems

Problems that do not occur all the time can be difficult to isolate during testing. For example, when a problem only occurs when the motorcycle is ridden over rough roads (vibration) or in wet conditions (water penetration). Note the following:

1. Vibration. This is a common problem with loose or damaged electrical connectors.
  - a. Perform a continuity test as described in the appropriate service procedure or under *Continuity Test* in this section.
  - b. Lightly pull or wiggle the connectors while repeating the test. Do the same when checking the wiring harness and individual components, especially where the wires enter a housing or connector.
  - c. A change in meter readings indicates a poor connection. Find and repair the problem or replace the part. Check for wires with cracked or broken insulation.

#### NOTE

*An analog ohmmeter is useful when making this type of test. Slight needle movements are visibly apparent, which indicate a loose connection.*

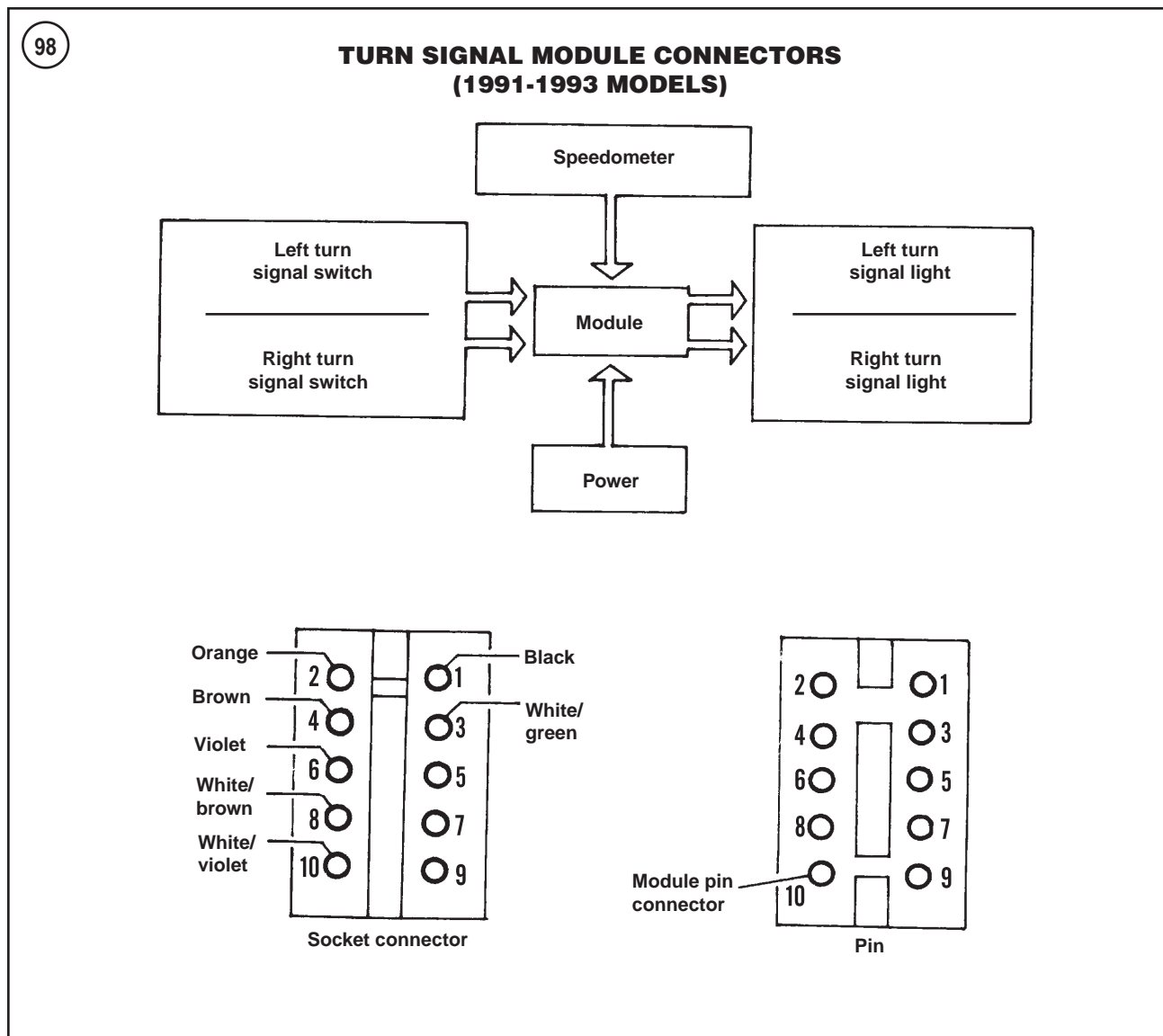

is in the diagnostic mode. All codes will be cleared whether they have been displayed or not.

8. To exit the diagnostic mode, turn the ignition switch from on to off and then to on again. Do not press the reset switch while doing so. Diagnostic codes are also cleared when the vehicle speed reaches 5 mph.

#### Speedometer/Tachometer Troubleshooting (1995-1998 Models, Except 1998 883 Models)

Find the symptom that best describes the condition in **Figure 93** or **Figure 94** and perform the indicated test procedures. Some test procedures, however, require the use of the speedometer tester (part No. HD-41354). Take the motorcycle to a dealership when indicated to do so in the troubleshooting chart.

#### TURN SIGNAL MODULE (1991-1996 MODELS)

##### Performance Test (1991-1993 Models)

If the turn signals are not working properly, perform the following performance test. A jumper wire, ohmmeter and voltmeter will be required.

1. Remove the turn signal module as described in Chapter Twelve.
2. After removing the module, identify the socket connector and module pin connectors using the diagram in **Figure 98**.
3. With ignition switch off, check for ground at pin No. 1.
4. Turn the ignition switch on.
5. Check for voltage at pin No. 2. Voltmeter should read 12 volts.
6. Connect a jumper wire between pins No. 2 and No. 4. The right front and rear turn signal lights should illuminate.

3. Loose or worn steering head bearings.

### Stiff or Heavy Fork Operation

1. Incorrect fork oil viscosity.
2. Excessive amount of fork oil.
3. Bent fork tubes.
4. Incorrect fork springs.

### Poor Fork Operation

1. Low fork oil level
2. Contaminated fork oil.
3. Worn or damaged fork tubes.
4. Bent or damaged fork tubes.
5. Incorrect fork springs.
6. Heavy front end loading from non-standard equipment.

### Poor Rear Shock Absorber Operation

1. Rear shocks adjusted incorrectly.
2. Incorrect loading.
3. Heavy rear end loading from non-standard equipment.
4. Weak or worn springs.
5. Damper unit leaking.
6. Shock shaft worn or bent.
7. Incorrect rear shock springs.

## BRAKE PROBLEMS

All models are equipped with front and rear disc brakes. Perform the maintenance specified in Chapter Three to minimize brake system problems. Brake system service is covered in Chapter Sixteen. When refilling the front and rear master cylinders, use only DOT 5 silicone-based brake fluid.

### Insufficient Braking Power

Worn brake pads or disc, air in the hydraulic system, glazed or contaminated pads, low brake fluid level, or a leaking brake line or hose can cause this problem. Visually check for leaks. Check for worn brake pads. Also check for a leaking or damaged primary cup seal in the master cylinder. Bleed and adjust the brakes. Rebuild a leaking master cylinder or brake caliper. Brake drag will result in excessive heat and brake fade. See *Brake Drag* in this section.

### Spongy Brake Feel

This problem is generally caused by air in the hydraulic system. Bleed and adjust the brakes as described in Chapter Sixteen.

### Brake Drag

Check brake adjustment. Check for insufficient brake pedal and/or hand lever free play. Also check for worn, loose or missing parts in the brake calipers. Check the brake disc for warp or excessive runout.

### Brakes Squeal or Chatter

Check brake pad thickness and disc condition. Make sure that the pads are not loose. Check that the anti-rattle springs are properly installed and in good condition. Clean off any dirt on the pads. Loose components can also cause this. Check for:

1. Warped brake disc.
2. Loose brake disc.
3. Loose caliper mounting bolts.
4. Loose front axle nut.
5. Worn wheel bearings.
6. Damaged hub.

**Table 1 and Table 2 are on the following page.**

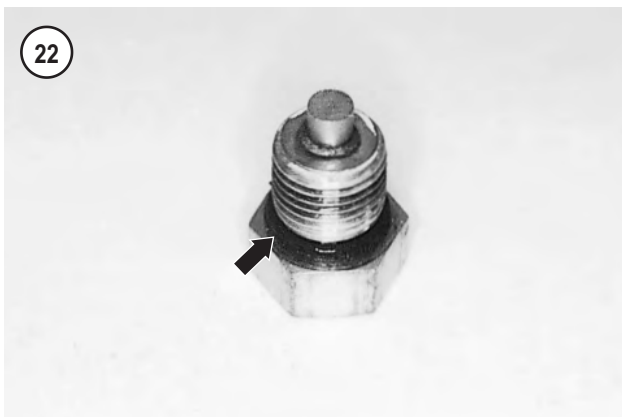
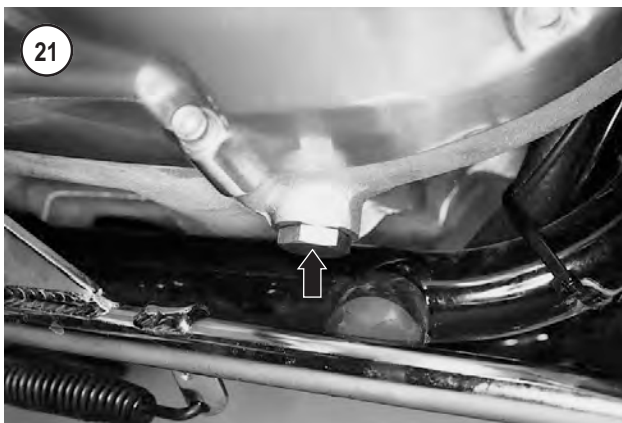
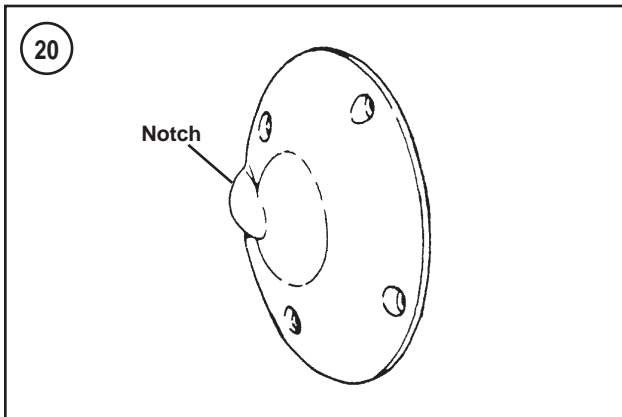

6A. On 1986-1990 models, remove the access cover (B, **Figure 14**) and refill with the recommended quantity (**Table 4**) and type (**Table 5**) transmission oil.

6B. On 1991-1993 models, remove the inspection cover (**Figure 16**) and refill with the recommended quantity (**Table 4**) and type (**Table 5**) transmission oil.

7. Check the oil level as described in this section.

### Transmission oil change (1994-2003 models)

**Table 1** lists the recommended transmission oil change intervals.

1. Ride the motorcycle for approximately ten minutes and shift through all five gears until the transmission oil has reached normal operating temperature. Turn off the engine and allow the oil to settle in the case. Park the motorcycle on a level surface and have an assistant support it so that it is standing straight up.

2. Place a drain pan underneath the engine and remove the oil drain plug (**Figure 21**).

3. Inspect the drain plug O-ring (**Figure 22**) for damage and replace it if necessary.

4. The drain plug is magnetic. Check the plug for metal debris that may indicate transmission damage, then wipe off the plug. Replace the plug if it is damaged.

5. Install the drain plug and O-ring and tighten to 14-21 ft.-lb. (19-28 N•m).

6. Clean the area around the clutch inspection cover (**Figure 17**).

7. Remove the clutch inspection cover retaining screws, then remove the cover (**Figure 17**).

#### NOTE

*The primary drive cover is removed in **Figure 18** for clarity. It is not necessary to remove the cover.*

8. Refill the transmission through the opening in the primary drive cover with the recommended quantity (**Table 4**) and type (**Table 5**) of transmission oil. The transmission oil level should be even with the bottom of the clutch diaphragm spring (**Figure 19**).

9. Install the clutch inspection cover. Tighten the retaining screws to 84-108 in.-lb. (10-12.0 N•m).

10. Check the oil level as described in this section.

### Fork Oil Change

This procedure is for a fork oil change. If the fork has been disassembled for service, refer to Chapter Fourteen for fork oil refilling and specifications.

**Table 1** lists the recommended fork oil change intervals.

#### CAUTION

*Do not allow the fork oil to come in contact with the brake components.*



## Brake Fluid Change

### WARNING

Do not use brake fluid labeled DOT 5.1. This is a glycol-based fluid that is not compatible with silicone-based DOT 5. DOT 5 brake fluid is purple while DOT 5.1 is an amber/clear color. Do not intermix these different types of brake fluid, as doing so will lead to brake component damage and possible brake failure.

To change brake fluid, follow the brake bleeding procedure in Chapter Sixteen. Continue adding new fluid to the master cylinder until the fluid leaving the caliper is clean and free of contaminants and air bubbles.

## Front Brake Adjustment

The front brake does not require periodic adjustment.

## Rear Brake Adjustment

### 1986-early 1987 models

1. Sit on the motorcycle in normal riding position. Adjust the position of the brake pedal to suit rider preference as described in the following steps.
2. Loosen the locknuts (A, **Figure 54**) on the pedal adjusting screw (B).
3. Turn the adjusting screw (B, **Figure 54**) until the desired pedal position is obtained.

4. Tighten the locknuts (A, **Figure 54**) and recheck the pedal position.
5. Push the brake pedal by hand until light resistance is felt, which indicates the pushrod (17, **Figure 55**) is contacting the piston (12).
6. Measure the gap between the adjusting screw (B, **Figure 54**) and the brake pedal. The gap should be 1/16 in. (1.6 mm). If not, proceed as follows:
  - a. Loosen the locknut (18, **Figure 55**).
  - b. Turn the pushrod (17, **Figure 55**) as needed to obtain the desired gap.
  - c. Tighten the locknut (18, **Figure 55**).

### Later 1987-2003 models, except 1999-2003 883C and 1200C models

1. Park the motorcycle on level ground so the motorcycle is upright.
2. Note the brake pedal position with relation to the floor. The brake pedal (**Figure 56**) should be parallel with the floor.
3. Remove the cotter pin securing the clevis pin (A, **Figure 57**) to the rear brake pedal. Remove the clevis pin.
4. Disconnect the brake rod end from the brake pedal.
5. Loosen the locknut (B, **Figure 57**) and turn the brake rod end (C) as needed to reposition the brake pedal.
6. When the brake pedal is properly positioned, reinstall the clevis pin and secure it with a new cotter pin.

### 1999-2003 883C and 1200C models

Refer to the *Forward Foot Controls* section in Chapter Seventeen.

## Clutch Adjustment

### 1986-1993 models

### NOTE

The clutch cable adjuster on 1986-1987 models is located at the lower end of the cable (A, **Figure 58**). On 1988-1993 models, the cable adjuster is located at mid-length in the cable adjacent to the front frame down-tube (**Figure 59**).

Refer to **Figure 60** when performing this procedure.

- 1A. On 1986-1987 models, loosen the clutch cable jam nut (B, **Figure 58**) and turn the adjuster (A) to provide maximum cable slack.
- 1B. On 1988-1993 models, slide the rubber boot off the clutch in-line cable adjuster. Loosen the adjuster jam nut (A, **Figure 59**) and turn the adjuster (B) to provide maximum cable slack.
2. Make sure the clutch cable ferrule seats squarely in the lever housing receptacle (**Figure 61**) on the handlebar.
3. Remove the clutch inspection cover (**Figure 62**).



head gasket, valves and cylinders). It is a good idea to check compression at each tune-up, record it in the maintenance log at the back of the manual, and compare it with subsequent readings.

Use a screw-in type compression gauge with any necessary adapter (refer to Chapter One). Before using the gauge, make sure the rubber gasket on the end of the gauge hose adapter is in good condition.

1. Before starting the compression test, make sure the following items are correct:

- a. The battery is fully charged (Chapter Twelve).

- b. The cylinder head bolts are properly tightened (Chapter Four).
2. Run the engine until it reaches normal operating temperature, then turn it off.
3. Remove all the spark plugs as described in this chapter.
4. Connect a grounding tool (Chapter One) to the spark plug wires to prevent damage to the ignition system components.
5. Lubricate the threads of the compression gauge adapter with a small amount of antiseize compound and thread the gauge into one of the spark plug holes.

#### NOTE

*On 1986-1987 models make sure the choke is off.*

6. Move the engine stop switch to the run position, then turn the ignition switch to the ignition position. Open the throttle completely and crank the engine until there is no further rise in pressure. Maximum pressure is usually reached within 4-7 seconds of engine cranking. Record the reading and the cylinder location.
7. Repeat Step 5 and Step 6 for the other cylinder.
8. When interpreting the results, actual readings are not as important as the difference between the readings. Compression is considered normal if the indicated pressure is 120 psi (828 kPa), and the compression reading of a cylinder does not differ from the remaining cylinder by 10 psi (69 kPa). Low compression indicates worn or broken rings, leaky or sticky valves, blown head gasket or a combination of all three.
  - a. If the compression reading does not differ between cylinders by more than 10 percent, the rings and valves are in good condition.
  - b. If a reading difference of 10 percent or more is obtained on one of the cylinders, it indicates valve or piston ring trouble. To determine which, pour about a teaspoon of engine oil into the spark plug hole of the cylinder with low compression. Turn the engine over once to distribute the oil, then take another compression test and record the reading. If the compression increases significantly, the valves are good but the rings are defective in that cylinder. If compression does not increase, the valves require servicing.
9. Install the spark plugs as described in this chapter.

## SPARK PLUGS

### Removal

As each spark plug is removed, label it with its cylinder location and refer to *Reading* in this section.

1. Grasp the spark plug lead (**Figure 84**) by the cap portion, not by the wire. Pull the lead off the plug.

## CHAPTER FOUR

# ENGINE TOP END

This chapter covers the rocker covers, rocker arms, cylinder heads, valves, cylinder blocks, pistons, piston rings and oil tank.

**Tables 1-4** are located at the end of this chapter.

### TOOLS

Engine service requires a number of special tools. These tools and their part numbers are listed with the individual procedures. For a complete list of the special tools mentioned in this manual, refer to **Table 12** in Chapter One.

When purchasing tools from a dealership or parts supplier, be sure to specify the tools required are for the specific Sportster model being worked on. Many of the tools are specific to the engine. Tools for other engine models may be slightly different.

The manufacturer's part number is provided for many of the tools mentioned in this manual. These part numbers are correct at the time of original publication. The publisher cannot guarantee the part number or the tools in this manual will be available in the future.

### ROCKER COVER ASSEMBLY

The rocker cover assembly (**Figure 1**) consists of the outer rocker cover, middle rocker cover and inner rocker cover, which contains the rocker arms and shafts.

The rocker covers can be removed from either cylinder with the engine installed in the frame.

#### Rocker cover

##### Removal

Refer to **Figure 1**.

1. Remove the fuel tank as described in Chapter Ten or Chapter Eleven.
2. Remove the air filter and backplate as described in Chapter Ten or Chapter Eleven.
3. If removing the rocker cover on the front cylinder, remove the ignition coil as described in Chapter Twelve.

##### NOTE

*Some rocker cover bolts have a captive washer. Note their position so they can be installed in the correct location*

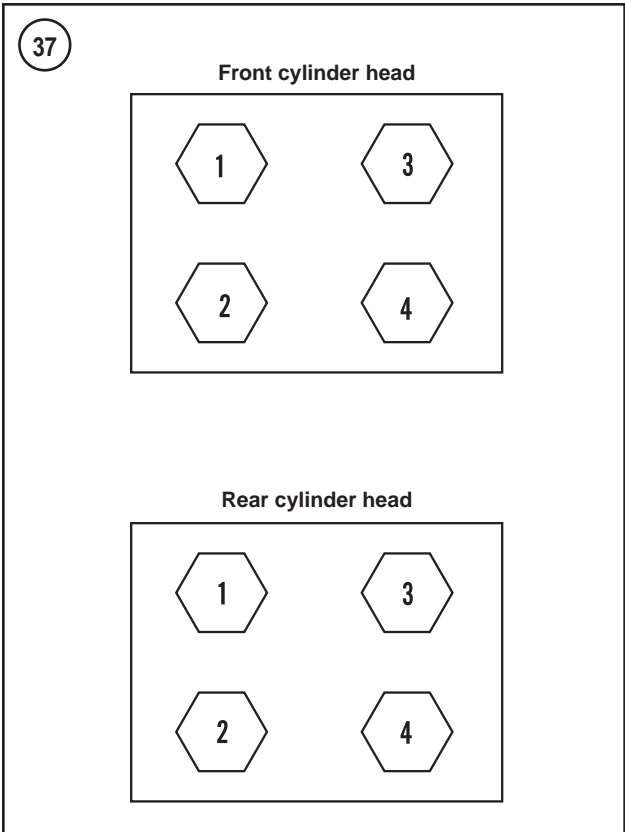
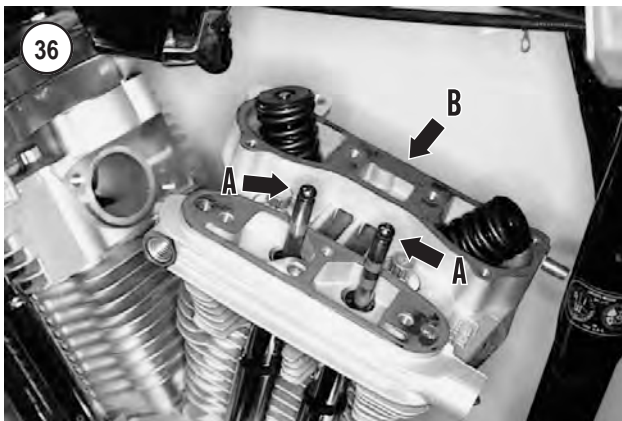
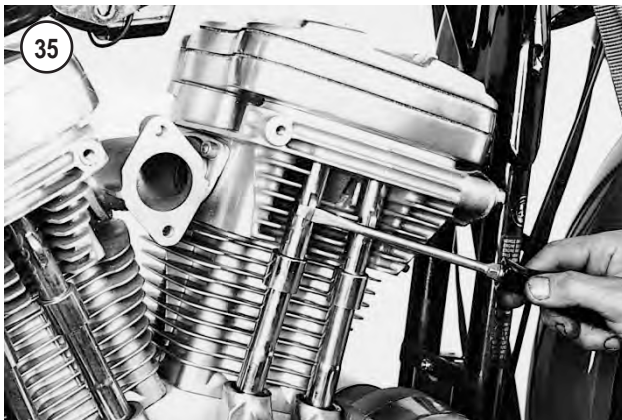

operating conditions, different cleaning techniques and procedures will be required.

- a. First scrape the upper and lower gasket surfaces. Work slowly and carefully, making sure not to scratch or gouge these surfaces. Damage could cause the head to leak when it is returned to service.

**CAUTION**

*Use only solvent or cleaners that are compatible with aluminum parts.*

- b. Soak the head in a solvent tank. This will help to soften the carbon buildup in the combustion chambers and exhaust port and to remove oil and grease

from the head surfaces. If a solvent tank is not available, spray the head with an aerosol cleaner, following the manufacturer's instructions. Then wash the head in hot, soapy water and rinse with clear, cold water. Dry with compressed air.

**CAUTION**

*Do not use a power-driven wire brush to clean the combustion chambers (Figure 39). The bristles may leave scratches that could become hot spots when the head is returned to service.*

- c. Bead-blasting is the most efficient way of removing deposits from the combustion chamber. If scraping

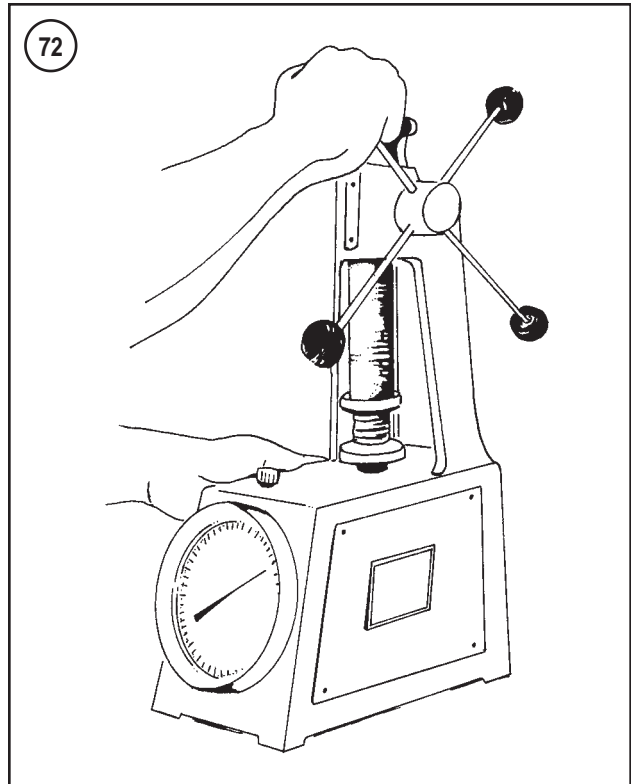
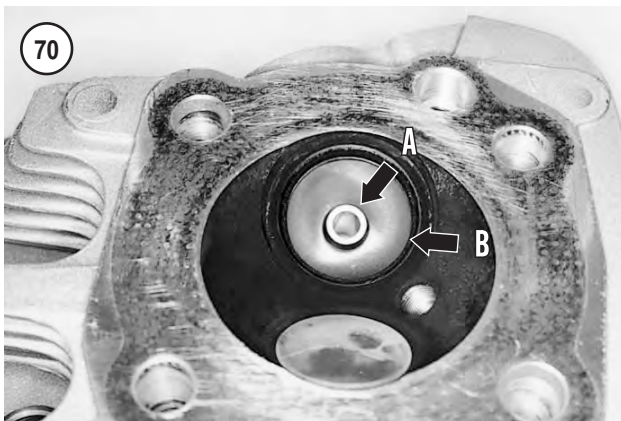
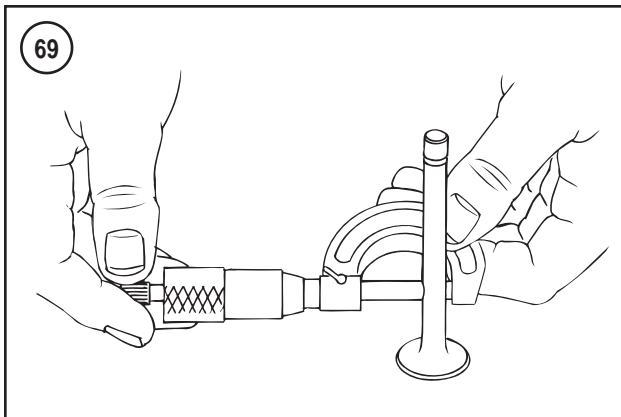
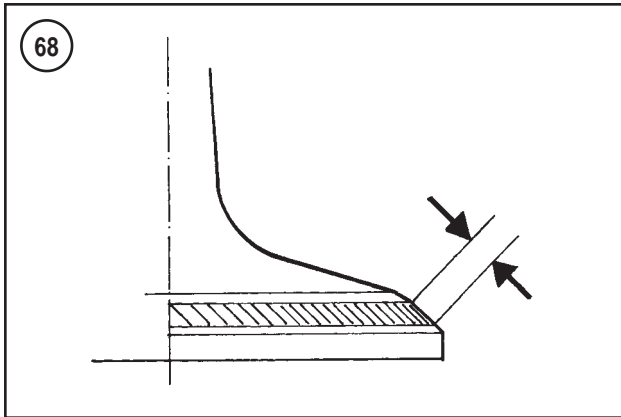

1. Make sure to have the following tools available before starting this procedure:

- a. Driver handle and remover (part No. HD-34740 or equivalent). By itself, this tool is used to remove the valve guides. This tool, along with the valve guide installation tool, is used to install the valve guides.
- b. Valve guide installation tool (part No. HD-34731A or equivalent). Part of HD-34731A is a sleeve that indicates when correct valve guide installation position is achieved. If this specific tool is not used, measuring valve guide position before removal is necessary so the new guide can be installed in the same position
- c. Valve guide reamer (part No. HD-39932, HD-39932-CAR or equivalent). This tool is used to ream the valve guides after they have been installed in the cylinder head.
- d. Valve guide hone (part No. HD-34723 or equivalent). This tool is used to hone the valve guides after reaming them to size.
- e. Valve guide brush (part No. HD-34751 or equivalent). This tool is used to clean the valve guides after honing them.
- f. Honing oil. Only honing oil should be used when honing the valve guides.

2. Place the cylinder head on a wooden surface so that the combustion chamber faces down.

3. Shoulderless valve guides are used. Before removing the guides, note and record the shape of the guide that projects into the combustion chamber. Measure the distance from the top of the guide to the cylinder head surface as

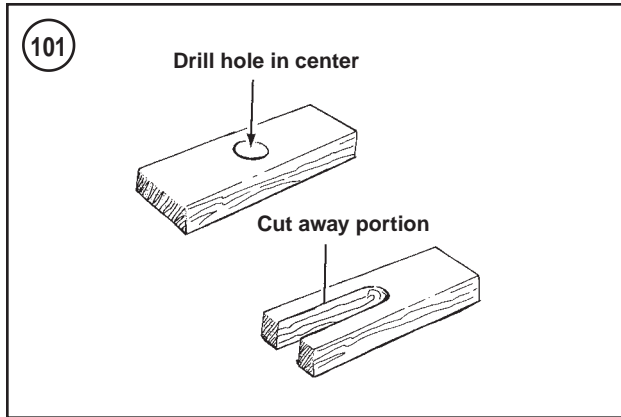

**CAUTION**  
 While the cylinder is removed, use care when working around the cylinder studs to avoid bending or damaging them. A bend could cause a stud failure later during engine operation.

10. Remove the pistons and rings as described in this chapter.
11. Repeat Steps 1-10 for the remaining cylinder.

### Inspection

To obtain an accurate cylinder bore measurement, the cylinder must be secured between torque plates. Torque plates are available from several sources. This arrangement simulates the distortion imparted on a cylinder when it is clamped down by the cylinder head and the cylinder bolts are tightened to the specified torque. Measurements made without the engine torque plate can vary by 0.001 in. (0.025 mm). If you do not have access to the torque plates, refer service to a dealership.

1. Remove all gasket residue from both cylinder gasket surfaces.
2. Thoroughly clean the cylinder with solvent and dry with compressed air.
3. Lightly coat the cylinder bore with clean engine oil to prevent rust.
4. Check the top (**Figure 102**) and bottom cylinder block gasket surfaces with a straightedge and feeler gauge. Replace the cylinder and piston if the following warp limits are exceeded:
  - a. Top cylinder surface: 0.006 in. (0.152 mm).
  - b. Bottom cylinder surface: 0.008 in. (0.203 mm).
5. Check the cylinder walls (**Figure 103**) for scuffing, scratches or other damage.
6. Install the torque plates onto the cylinder (**Figure 104**) following the manufacturer's instruction.
7. Measure the cylinder bore at the points shown in **Figure 105**. Initial measurement should be made at a distance of 0.500 in. (12.7 mm) below the top of the cylinder. The 0.500 in. (12.7 mm) depth represents the start of the ring path area; do not take readings that are out of the ring path area.
8. Measure in two axes—in line with the piston pin and at 90° to the pin. If the taper or out-of-round is greater than specifications (**Table 2**), rebore the cylinders to the next oversize and install new pistons and rings. Rebore both cylinders even though only one may be worn.
9. Have a dealer or machine shop confirm all cylinder measurements before ordering replacement parts.

**CAUTION**  
 Hot soapy water is the only solution that will completely clean the cylinder walls. Solvent and kerosene cannot wash fine grit out of the cylinder crevices. Residual abrasive grit in

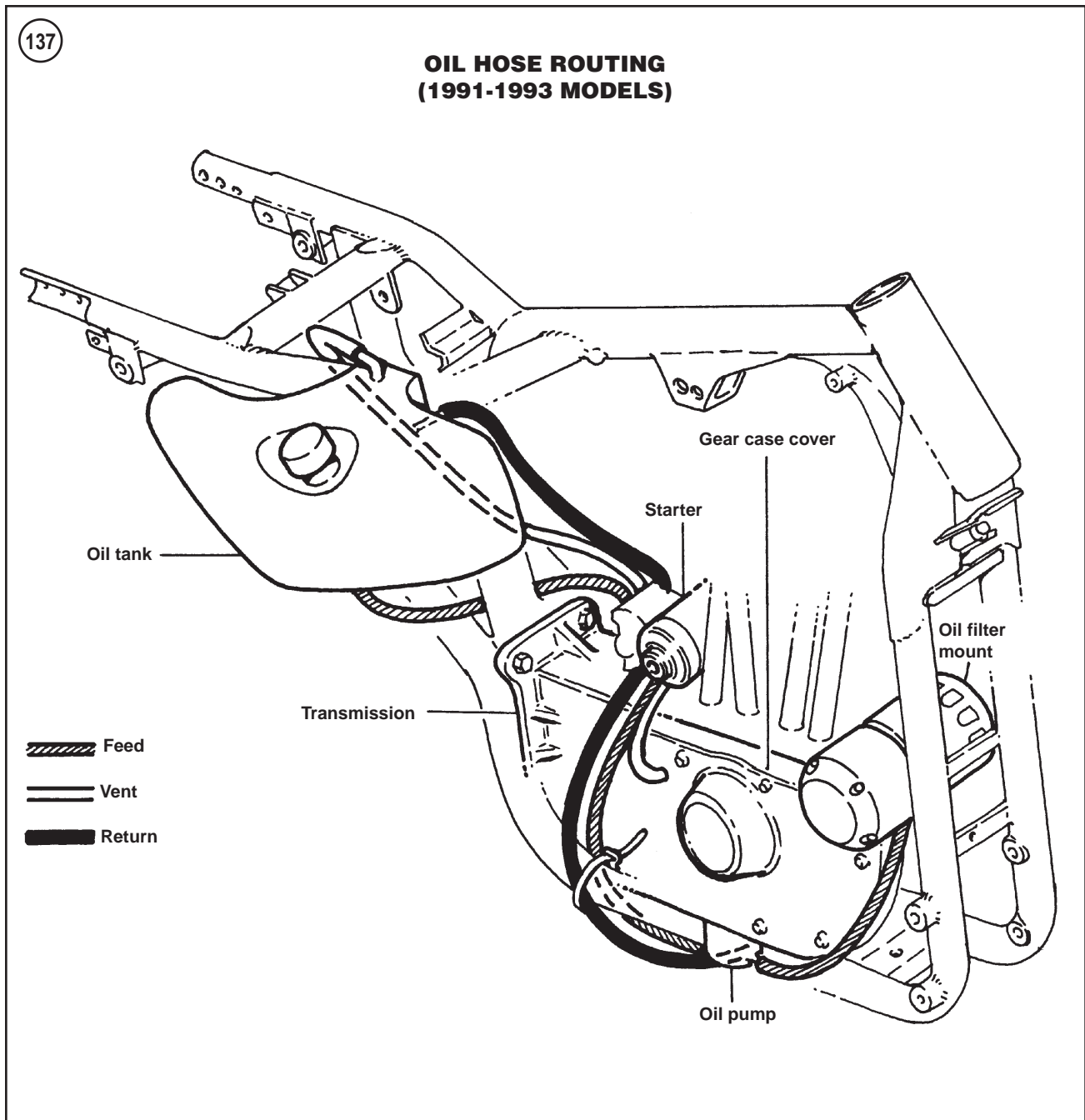

not replaceable; the fittings and hose are available only as a unit assembly.

### Oil Tank

*NOTE*

*An improved oil tank is available to replace the oil tank on 1986-1993 models.*

### Removal/installation

Refer to **Figures 136-138** when performing the following procedure.

1. Drain the oil tank (Chapter Three).
2. Remove the battery (Chapter Twelve).
3. Detach the ignition module connector from the battery tray by pushing the connector up (Chapter Twelve).
4. Unscrew the fasteners and remove the battery tray. Note the location of the positive battery cable retainer.
5. Remove the electrical component panel from the frame (Chapter Twelve).
6. Refer to **Figure 139**. Detach the vapor valve clip, disconnect the upper end of the valve from the hose and move the vapor valve out of the way.

7

### TOP FRONT ENGINE MOUNT

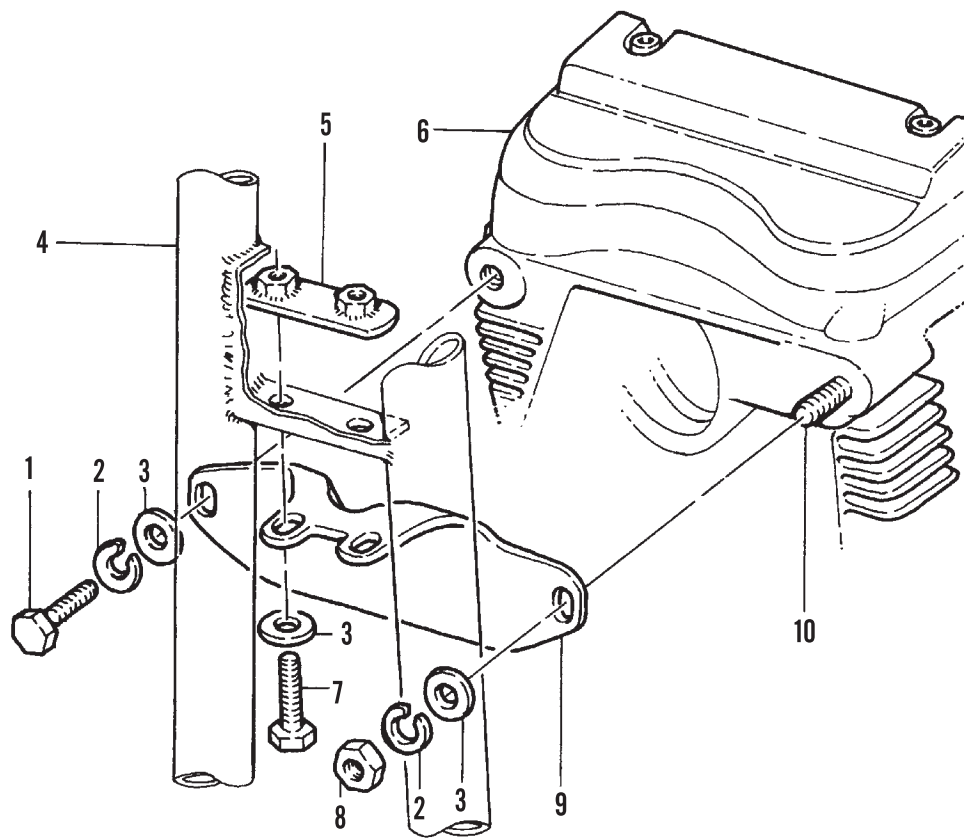

- 1. Bolt
- 2. Lockwasher
- 3. Washer
- 4. Frame downtube
- 5. Nut plate
- 6. Engine
- 7. Bolt
- 8. Nut
- 9. Top front engine mount
- 10. Stud



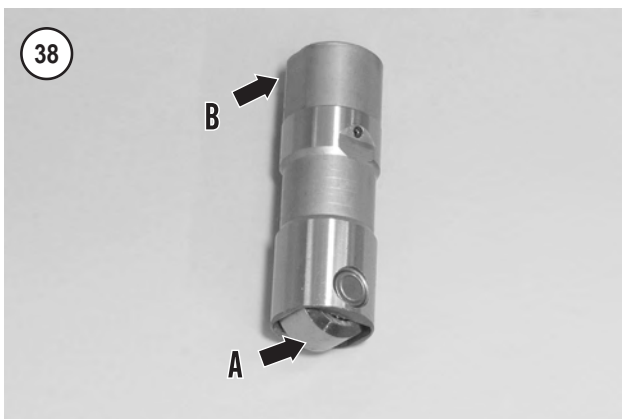
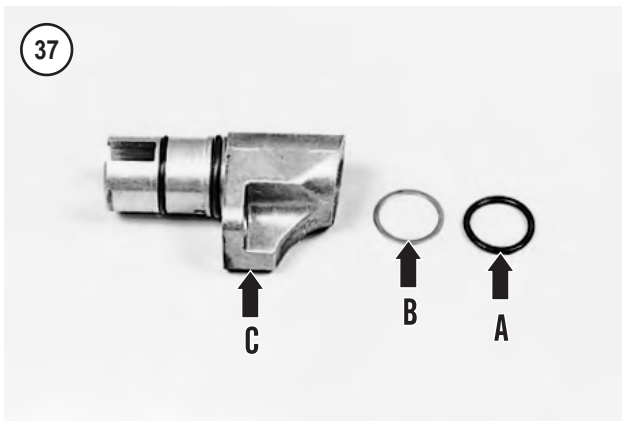
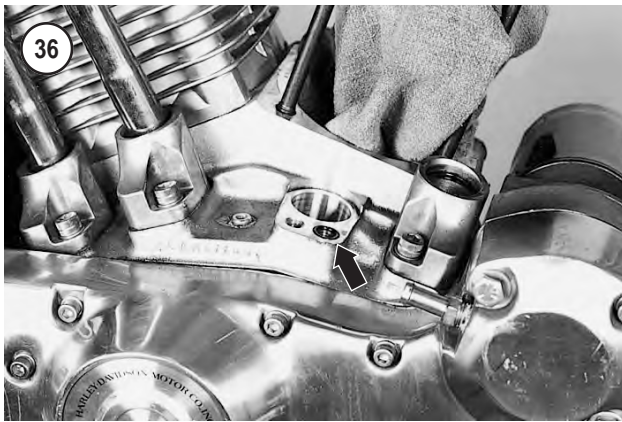

5

3. Remove the tappet guide bolts (Figure 34).
4. Rotate front tappet guides clockwise or rear tappet guides counterclockwise and remove the guides).

*NOTE*

*If the tappet is tight in the guide, tap it lightly with a rubber-faced hammer and remove it.*

5. Remove the tappet (Figure 35) from the guide. Store the tappets in a container of oil so they can be installed in their original position. Cover the storage container so debris cannot contaminate the oil.
6. Discard the crankcase O-ring (Figure 36).

**Cleaning and Inspection**

*CAUTION*

*Tappets must be stored and handled carefully to prevent contamination from debris. When storing tappets, leave them in the container of engine oil they were placed in during removal. When measuring or inspecting tappets, place them on a clean, lint-free cloth.*

*NOTE*

*The tappet is available only as a unit assembly.*

1. Remove the O-ring (A, Figure 37) and spacer(B) from the tappet guide (C).
2. Except for the roller/tappet assembly, clean all parts in solvent and allow to dry thoroughly.
3. Check the tappet rollers (A, Figure 38) for pitting, scoring, galling or excessive wear. If the rollers are worn excessively, check the mating cam lobes for the same wear conditions. The cam lobes can be observed through the tappet guide hole in the crankcase. Replace the cam, if necessary, as described in this section.
4. Inspect the tappet socket (Figure 39, typical) for pitting, scoring, galling or excessive wear.
5. Determine valve tappet guide clearance as follows:

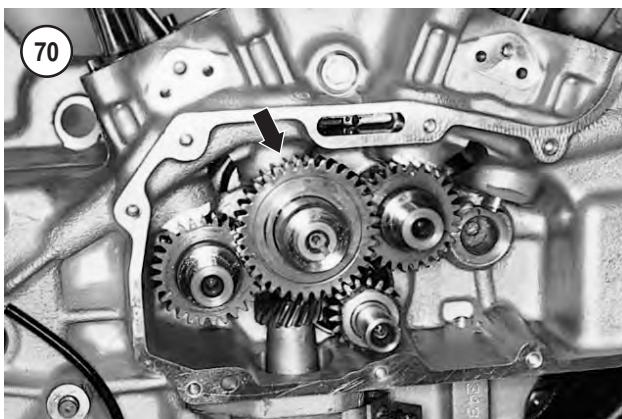
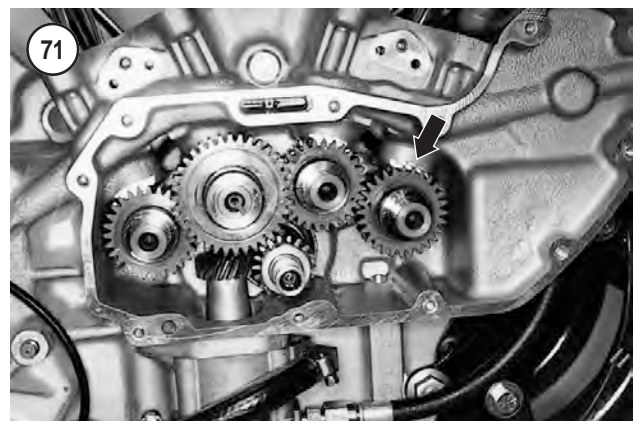
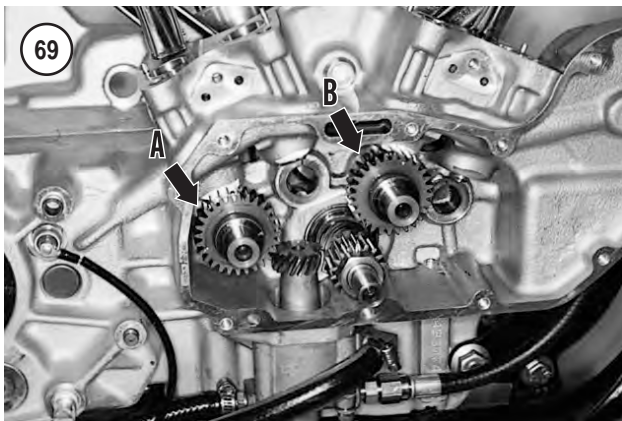
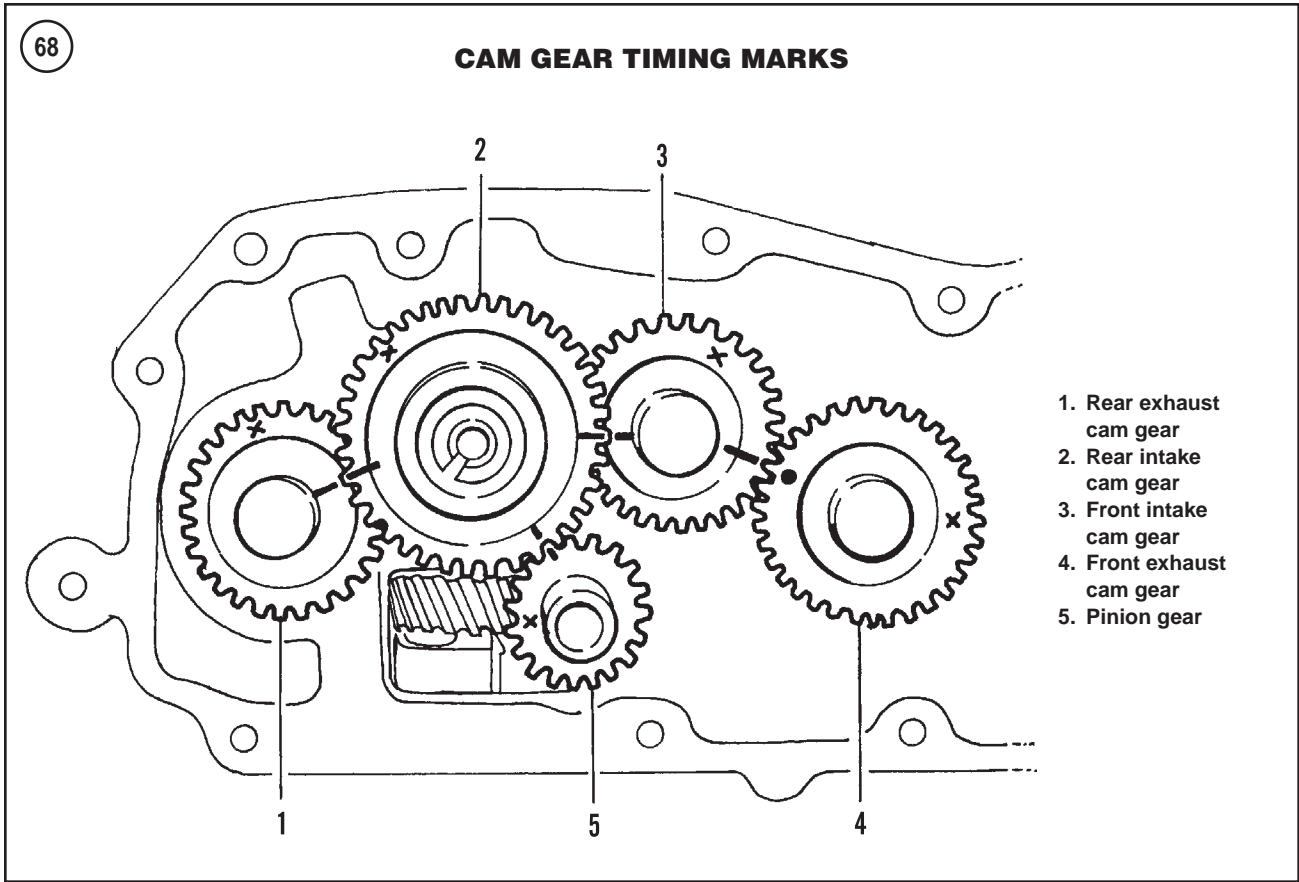

17. Install the valve tappets as described in this chapter.
18. Install the footpeg assembly as described in Chapter Seventeen.
19. Install the exhaust system as described in Chapter Ten or Chapter Eleven.

### OIL PUMP (1986-1990 MODELS)

The oil pump is mounted underneath the front of the engine and can be removed with the engine installed in the frame and without removing the gearcase cover.

The oil pump consists of two sections: a feed pump, which supplies oil under pressure to the engine components

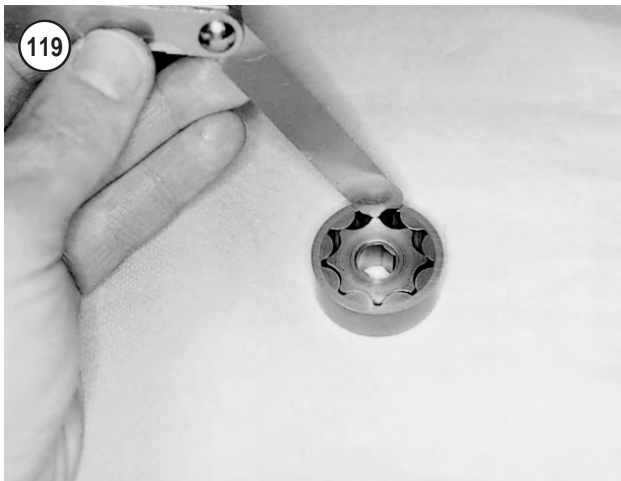

**NOTE**  
If the oil hose fittings were removed from the oil pump, apply pipe sealant to the fitting threads prior to installation.

### Installation

1. Thoroughly clean the oil pump and engine case gasket surfaces.

2. Install a new oil pump gasket. Then install the oil pump onto the crankcase. Tighten the oil pump mounting screws (**Figure 102**) to 125-150 in.-lb. (14-17 N•m).

**NOTE**  
When installing the original equipment (OE) hose clamps, refer to Chapter Four. A screw-type hose clamp may be substituted in place of the OE hose clamp.

3. Unplug, then reconnect the oil hoses (**Figure 101**) at the oil pump. Secure each hose with new hose clamps.

**NOTE**  
If the oil hose fittings were removed from the oil pump, apply pipe sealant to the fitting threads prior to installation.

4. Refill the oil tank (Chapter Three).

### OIL FILTER MOUNT (1986-1990 MODELS)

The oil filter mount is located on the right crankcase half. The oil filter mount houses the oil filter, check ball or valve and spring, and oil pressure switch. Refer to **Figure 121**.

### Removal/Installation

1. Drain the engine oil (Chapter Three).
2. If it is necessary to disassemble the oil filter mount, remove the oil filter.
3. Disconnect the electrical connector from the oil pressure regulator switch (Chapter Twelve).
4. Disconnect the two pressure hoses (**Figure 122**) from the oil pump.
5. Remove the filter mount-to-gearcase bolts and pull the filter mount away from the gearcase.
6. Remove the quad seal (2, **Figure 121**).
7. Installation is the reverse of the preceding steps while noting the following.
  - a. Install a *new* quad seal.
  - b. Refill the engine oil and install the oil filter as described in Chapter Three.
  - c. Prime the oil pump as described in *Engine Oil and Filter Change* (Chapter Three).

### Disassembly/Reassembly

1. Disconnect the two pressure hoses from the filter mount (**Figure 122**).
- 2A. On 1986-early 1987 models, remove the oil filter adapter as follows:
  - a. Unscrew the filter adapter.
  - b. Push the check valve out of the filter adapter with a 5/16 in. (7.94 mm) diameter rod.

**NOTE**

*The large end of the installer base must contact the crankcase outer surface as shown in Figure 150.*

21. Place the installer base on the press bed with the large end facing up.
22. Install the inboard outer race (**Figure 151**) onto the crankcase receptacle.
23. Position the crankcase with the inboard surface facing up.
24. Install the crankcase onto the installer base so the crankcase retaining ring rests on top of the installer base.
25. Apply clean engine oil, or press lube, to the shaft of the pressing plug (**Figure 152**) and install the pressing plug into the installer base. Push it down onto the bearing outer race (**Figure 153**).
26. Center the press ram directly over the pressing plug and press the outer bearing race into the outboard surface of the crankcase until it touches the retaining ring (**Figure 154**).
27. Remove the crankcase and special tools from the press.
28. Turn the crankcase over and repeat Steps 20-27 for the outboard outer bearing race.

**Crankshaft inner sprocket shaft bearing replacement**

A sprocket shaft bearing cone installer (part No. HD-37047A for 1986-1997 models or HD-42759 for 1998-2003 models) is required to install the sprocket shaft bearing.

1. Support the crankshaft with the bearing side facing up.
2. Install the bearing splitter under the bearing (**Figure 155**) and tighten it securely.

## CHAPTER SIX

# PRIMARY DRIVE AND CLUTCH (1986-1990 MODELS)

This chapter covers the primary drive cover, primary drive, clutch assembly and clutch cable.

**Table 1** and **Table 2** are at the end of the chapter.

### PRIMARY DRIVE COVER

Refer to **Figure 1**.

#### Removal

1. Disconnect the negative battery cable (Chapter Twelve).
2. Drain the transmission oil (Chapter Three).
3. Remove the gearshift pedal and the left footpeg (Chapter Seventeen).
4. Loosen the locknut and unscrew the adjuster (A, **Figure 2**) to loosen the primary drive chain.
5. Remove the clutch inspection cover (B, **Figure 2**).
6. Remove the adjusting screw spring and lockplate (**Figure 3**).
7. Turn the clutch adjusting screw clockwise (**Figure 4**) until the nut can be removed, then remove the nut (**Figure 5**).

#### NOTE

*Different length screws secure the primary drive cover. Note the location and length of the screws.*

8. Remove the primary drive cover (C, **Figure 2**) and gasket.

9. If necessary, remove the dowel pins.

10. If necessary, service the following components as described in this chapter:

- a. Clutch mechanism adjuster
- b. Primary chain adjuster
- c. Shift shaft oil seal

#### Installation

1. Clean the primary drive cover and engine crankcase gasket surfaces in solvent and dry thoroughly.
2. If removed, install the clutch assembly and connect the clutch cable as described in this chapter.
3. Install the dowel pins, if removed.
4. Using a new gasket, install the primary drive cover onto the crankcase. Install the mounting screws and tighten to 80-110 in.-lb. (9-12 N•m).
5. Thread the nut (**Figure 5**) onto the clutch adjusting screw until the screw slot is accessible with a screwdriver. Then align and install the hex portion on the nut into the outer ramp recess. Turn the clutch adjusting screw (**Figure 4**) counterclockwise until the nut cannot be removed.

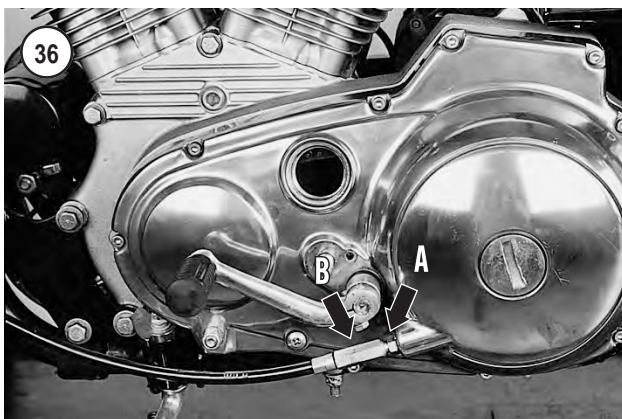
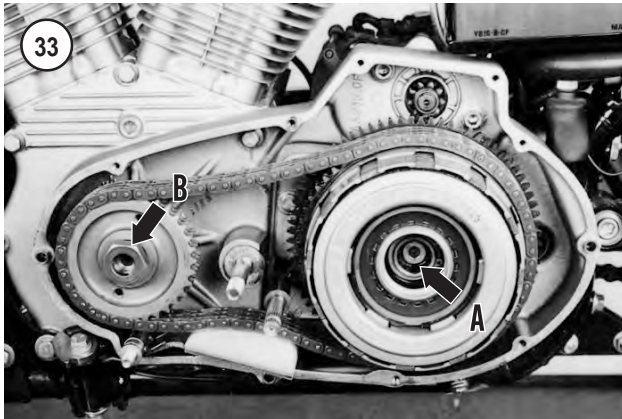

### Clutch Installation

1. Assemble the clutch assembly as described in this section.
2. The engine sprocket, primary chain and clutch are installed as an assembly. Assemble the engine sprocket, clutch and primary chain as shown in **Figure 31**.

#### CAUTION

*The alternator rotor is mounted on the clutch shell (**Figure 32**). Inspect the inside of the rotor for small bolts, washers or other metal debris picked up by the magnets. These metal pieces damage the alternator stator assembly.*

3. Lift the primary drive assembly as a unit and slide the engine sprocket and clutch into the primary chaincase (**Figure 33**).
4. Install the spacer and the clutch circlip (A, **Figure 33**) and spacer behind the circlip.
5. Use a sprocket locking tool to prevent engine sprocket rotation.

#### CAUTION

*The engine sprocket is tightened to a high torque specification. Be sure to hold the sprocket securely when tightening the nut.*

6. Apply of threadlock (Loctite 242 or equivalent) to the engine sprocket nut threads and then install the engine sprocket nut (B, **Figure 33**). Tighten the sprocket nut to 150-165 ft.-lb. (203-223 N•m).
7. Remove the sprocket locking tool.
8. Install the adjusting screw assembly (**Figure 34**) by aligning the two tabs on the release plate perimeter with the two recesses in the pressure plate.
9. Install a new snap ring (**Figure 35**).
10. Install the primary drive cover as described in this chapter.
11. Adjust the primary chain (Chapter Three).
12. Refill the primary chain housing with the correct type and quantity oil (Chapter Three).
13. Reconnect the negative battery cable (Chapter Twelve).

### CLUTCH CABLE

#### Replacement

Refer to **Figure 1** and **Figures 36-38**.

- 1A. On 1986-1987 models, loosen the clutch cable jam nut (A, **Figure 36**) and turn the adjuster (B) to provide maximum cable slack.
- 1B. On 1988-1990 models, slide the rubber boot off the clutch in-line cable adjuster. Loosen the adjuster jam nut (A, **Figure 37**) and turn the adjuster (B) to provide maximum cable slack.

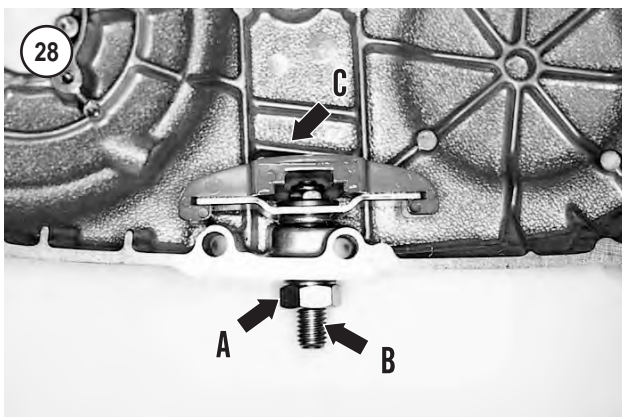
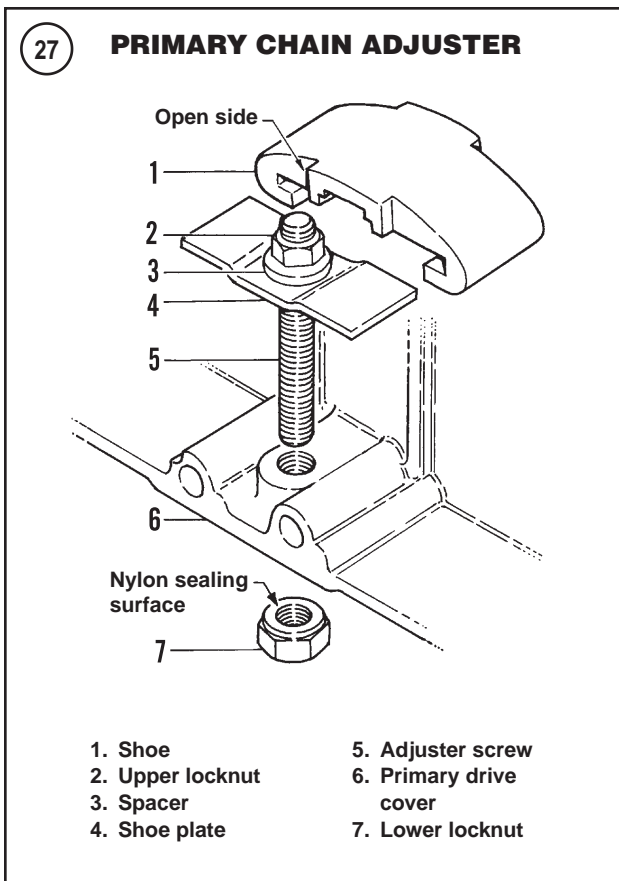
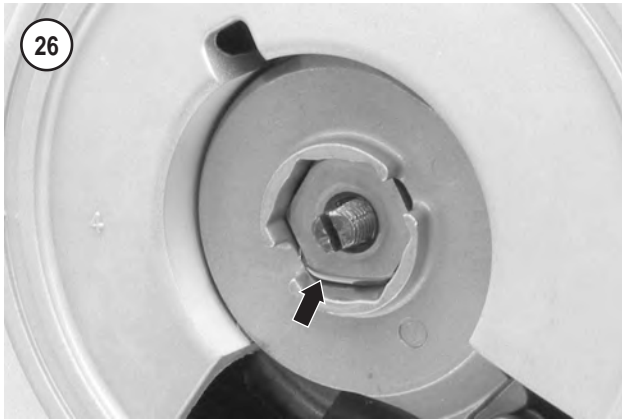

## PRIMARY CHAIN ADJUSTER

Refer to **Figure 27**.

The primary chain adjuster assembly is mounted inside the primary drive cover.

### Removal

1. Remove the primary drive cover as described in this chapter.
2. Remove the adjuster screw locknut (A, **Figure 28**).
3. Turn the adjuster screw (B, **Figure 28**) to remove it from the threaded boss in the primary drive cover.
4. Slide the adjuster shoe (C, **Figure 28**) off the shoe plate.
5. Remove the upper locknut and shoe plate.

### Inspection

1. Clean all parts in solvent and dry thoroughly.
2. Replace the adjuster shoe (C, **Figure 28**) if severely worn or damaged.
3. Replace the shoe plate if bent or otherwise damaged.
4. Replace the locknut(s) and adjuster screw if thread damage is apparent.

### Installation

1. Install the shoe plate over the top of the adjuster screw.
2. Place the spacer over the top of the adjuster screw and rest it on top of the shoe plate.
3. Thread the upper primary chain adjuster locknut onto the top of the adjuster screw. Tighten the upper locknut to 120-144 in.-lb. (14-16 N•m).
4. Slide the open side of the adjuster shoe over the shoe plate until the upper locknut is positioned against the closed side of the shoe.
5. Place the adjuster assembly into the primary drive cover so that the closed side of the adjuster shoe (C, **Figure 28**) faces toward the primary drive cover.
6. Thread the adjuster screw (B, **Figure 28**) into the boss at the bottom of the primary drive cover.
7. Thread the lower locknut (A, **Figure 28**) onto the adjuster screw.
8. Install the primary drive cover as described in this chapter.
9. Adjust the primary chain (Chapter Three).

## PRIMARY DRIVE/CLUTCH

Refer to **Figure 29**.

### Tools

Complete disassembly of the clutch requires the use of a clutch spring compression tool (**Figure 30** [part No. HD-38515A, 38515-90/91 or equivalent]). If the compress-

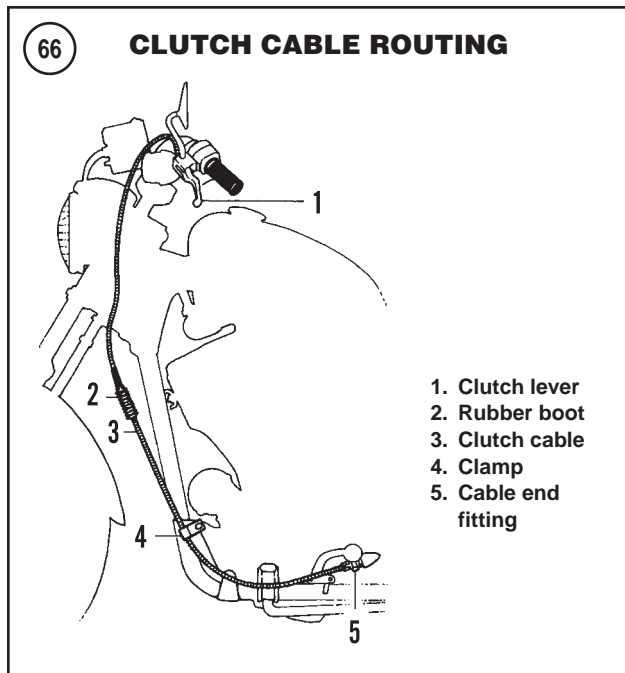
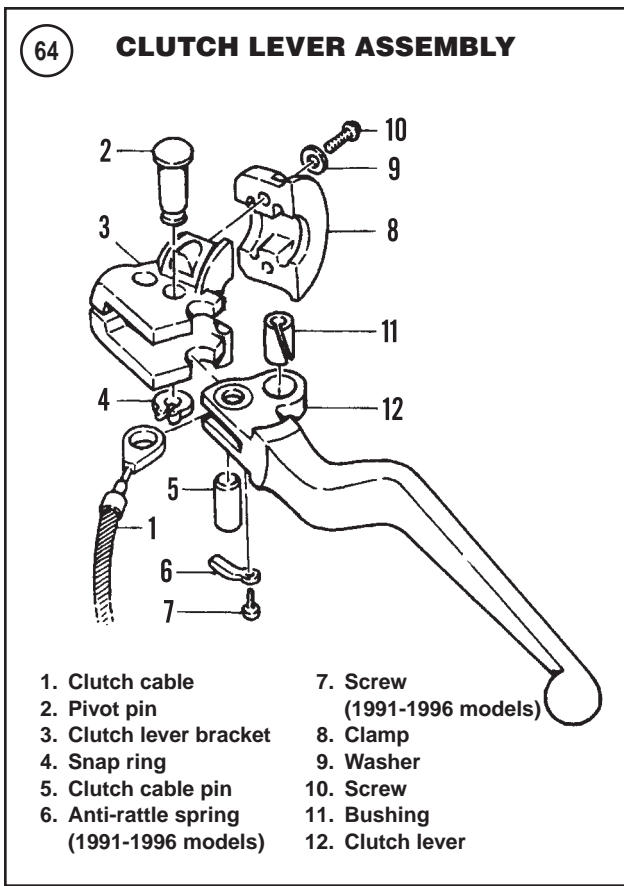

1. Remove the primary drive cover as described in this chapter.
2. Pry the lockplate tabs (A, **Figure 61**) away from the mounting screws and remove the lockplate and screws.
3. Remove the clutch release mechanism from the cover and disconnect the cable (B, **Figure 61**) from the ramp and coupling. Remove the release clutch mechanism (C, **Figure 61**).
4. Turn the clutch cable (**Figure 62**) counterclockwise and remove it from the primary drive cover.
5. Remove the O-ring (**Figure 63**) from the lower cable end fitting.
6. At the clutch lever, remove the pivot pin circlip and remove the pivot pin (2, **Figure 64**).
7. Slide the clutch lever out of the bracket (3, **Figure 64**).
8. Remove the clutch cable and disconnect the clutch cable from the lever (12, **Figure 64**).
9. Remove the screw and anti-rattle spring from the bottom of the clutch lever (6, **Figure 64**).
10. Note the cable routing before removing it. The new cable must be routed along the same path. Slide the clutch cable through the guide clip (**Figure 65**) and remove the clutch cable.
11. Slide the O-ring over the lower cable end fitting (**Figure 63**) and insert the cable into the primary drive cover. Turn the cable (**Figure 62**) clockwise and tighten it securely.
12. Connect the lower end of the clutch cable to the cable coupling. Connect the cable coupling to the outer ramp (**Figure 60**).
13. Install the clutch release mechanism and lockplate onto the primary drive cover with the mounting screws. Tighten the screws securely. Bend the lockplate tabs over the screw heads to lock them.
14. Install the primary drive cover as described in this chapter.
15. Route the clutch cable as shown in **Figure 66**.

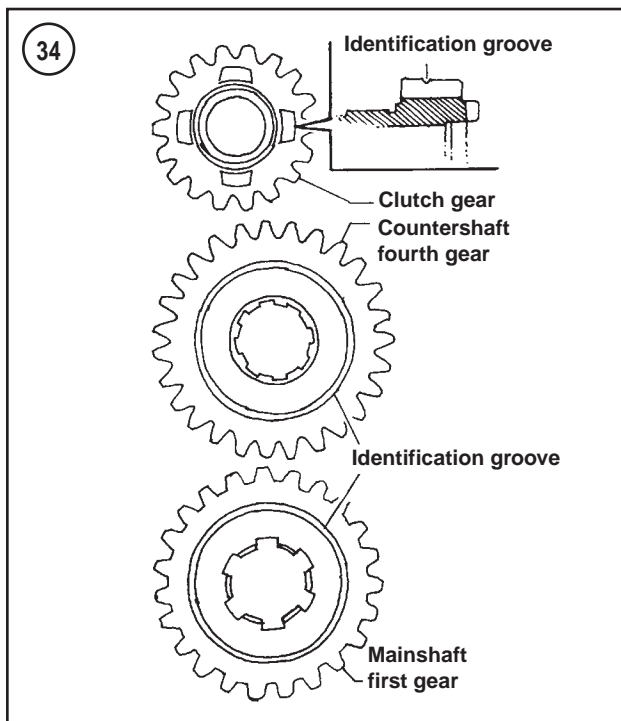
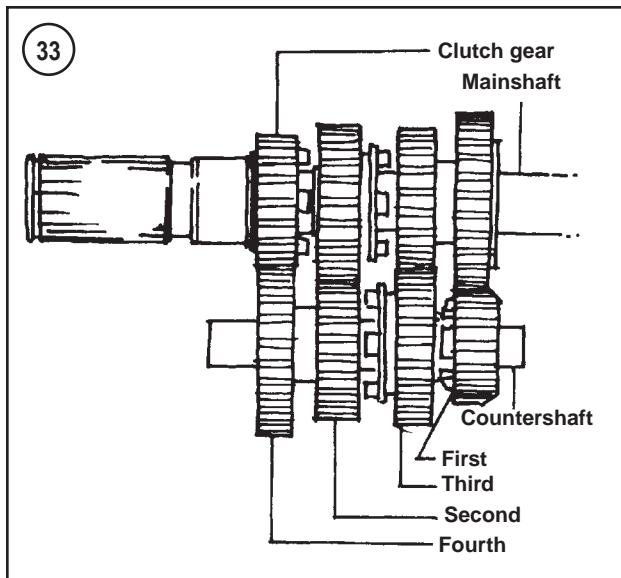

8. Check the shift forks (**Figure 31**) for cracks, deep scoring or excessive wear.
9. Shift fork length varies. If replacing a shift fork, be sure to replace it with one of the same length (**Figure 32**).

### Close Ratio Gear Installation

An internal gear ratio change was made starting on 1987 models. All 1987-1990 models are installed with close ratio gears. Refer to **Table 3** for a complete listing of gear ratios. Owners of 1986 models who wish to install close ratio gears should note the following:

1. The close ratio gear set is composed of three new gears: mainshaft first gear, countershaft fourth gear and the clutch gear. See **Figure 33**.
2. Close ratio gears are identified with grooves machined into the face of the gears. **Figure 34** identifies the new gears and their markings. Note that the clutch gear will have its groove cut into the dog faces.
3. Refer to **Figure 33** and note the following installation conditions:
  - a. The new mainshaft first gear can be used with any 17-tooth countershaft first gear.
  - b. A new clutch gear and countershaft fourth gear must be installed as a pair.
  - c. Service and installation procedures remain the same as for 1986 models.

### Access Cover Inspection/Bearing Replacement

#### CAUTION

*The needle bearings installed in the transmission gears, access cover and crankcase housing are press-fit. Replacement of these bearings requires a press or special bearing replacement tools. Driving in the bearings will damage them. If the proper tools are not available, refer replacement to a dealership.*

1. Check the clutch gear ball bearing (**Figure 35**).
2. Check the needle bearing (**Figure 36**) for wear or roughness.

**Table 1 TRANSMISSION SERVICE SPECIFICATIONS**

	<b>New in. (mm)</b>	<b>Service Limit in. (mm)</b>
<b>Clutch face clearance</b>		
Mainshaft 4th and 2nd gear	0.040 (1.02)	0.080 (2.03)
Mainshaft 3rd and 2nd gear	0.040 (1.02)	0.080 (2.03)
Clutch gear needle bearing journal diameter	0.7495-0.7500 (19.037-19.050)	0.7485 (19.012)
<b>Countershaft</b>		
Needle bearing journal diameter		
Access door	0.7500-0.7495 (19.050-19.037)	0.7490 (19.025)
Right crankcase side or end	0.6875-0.6870 (17.463-17.450)	0.6865 (17.437)
Countershaft end play	0.004 (0.10)	0.015 (0.38)
1st gear needle bearing journal diameter	0.6875-0.6870 (17.463-17.450)	0.6865 (17.437)
<b>Gear face clearance</b>		
Countershaft 1st and 3rd gear	0.040 (1.02)	0.080 (2.03)
Countershaft 2nd and 3rd gear	0.040 (1.02)	0.080 (2.03)
Mainshaft end play	0.006 (0.15)	0.020 (0.51)
Mainshaft 3rd gear end play	0.006-0.020 (0.15-0.51)	
Mainshaft and countershaft runout	—	0.003 (0.08)

8

**Table 2 EARLY AND LATE STYLE GEAR OUTSIDE DIAMETERS**

<b>Gear</b>	<b>Number or teeth</b>	<b>Outside diameter in. (mm)</b>
<b>Early style gears</b>		
Countershaft 2nd gear	20	2.448-2.452 (62.18-62.28)
Countershaft 3rd gear	23	2.648-2.657 (67.26-67.49)
Mainshaft 2nd gear	23	2.648-2.657 (67.26-67.49)
Mainshaft 3rd gear	20	2.448-2.452 (62.18-62.28)
<b>Late style gears</b>		
Countershaft 2nd gear	20	2.423-2.428 (61.54-61.67)
Countershaft 3rd gear	23	2.622-2.627 (66.60-66.73)
Mainshaft 2nd gear	23	2.622-2.627 (66.60-66.73)
Mainshaft 3rd gear	20	2.423-2.428 (61.54-61.67)

**Table 3 GEAR RATIOS**

	<b>1986 models</b>	<b>1987-1990 models</b>
<b>Internal gear ratios</b>		
1st	2.52	2.29
2nd	1.82	1.66
3rd	1.38	1.25
4th	1.00	1.00

(continued)

CLICK HERE TO **DOWNLOAD** THE COMPLETE MANUAL

- Thank you very much for reading the preview of the manual.
- You can download the complete manual from: [www.heydownloads.com](http://www.heydownloads.com) by clicking the link below



- Please note: If there is no response to CLICKING the link, please download this PDF first and then click on it.

CLICK HERE TO **DOWNLOAD** THE COMPLETE MANUAL

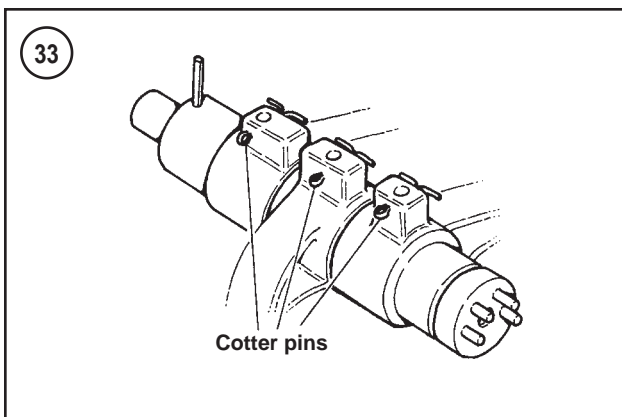
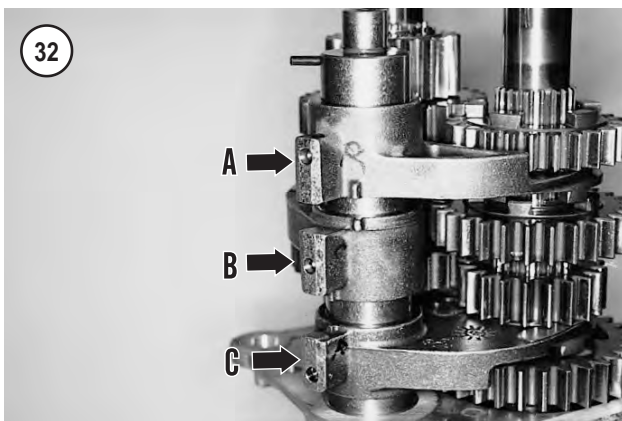
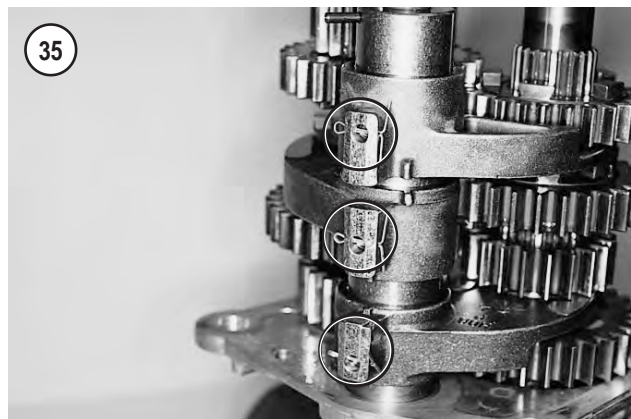
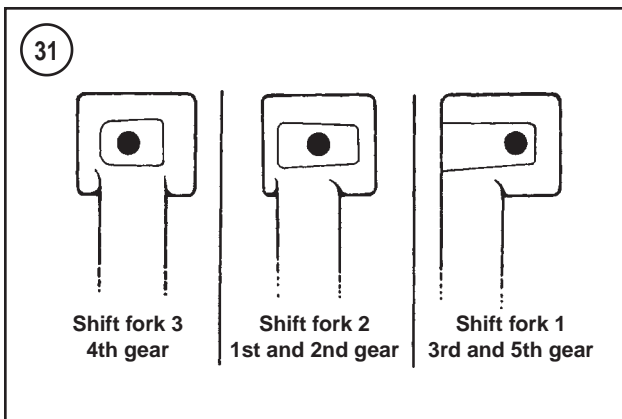
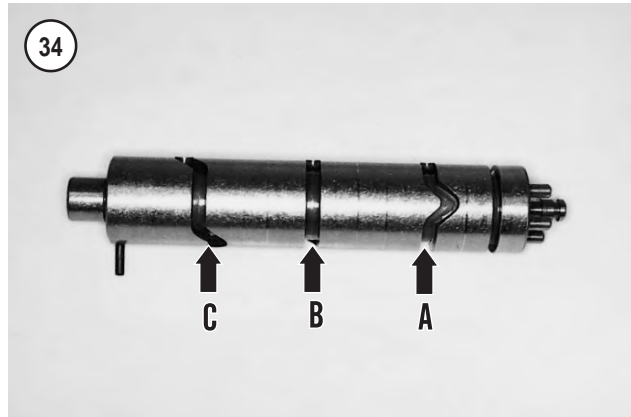

**CAUTION**

The cotter pins must be installed through the shift forks as shown in **Figure 33**. Otherwise, the cotter pins may be damaged during transmission operation.

8. Align the lower shift drum groove (A, **Figure 34**) with the pin hole in shift fork No. 3 (fourth gear); refer to C, **Figure 32**. Install the shift fork pin through the shift fork so it drops into the shift drum groove; turn the shift drum while pushing on the pin with a small screwdriver. Then install a new cotter pin.

9. Align the center shift drum groove (B, **Figure 34**) with the pin hole in shift fork No. 2 (first and second gear); refer to B, **Figure 32**. Install the shift fork pin through the shift drum so it drops into the shift drum groove; turn the shift drum while pushing on the pin with a small screwdriver. Then install a new cotter pin.

10. Align the upper shift drum groove (C, **Figure 34**) with the pin hole in shift fork No. 1 (third and fifth gear); refer to A, **Figure 32**. Install the shift fork pin through the shift drum so it drops into the shift drum groove; turn the shift drum while pushing on the pin with a small screwdriver. Then install a new cotter pin.

**NOTE**

Refer to **Figure 33** and **Figure 35** for the correct installation of the shift fork cotter pins.

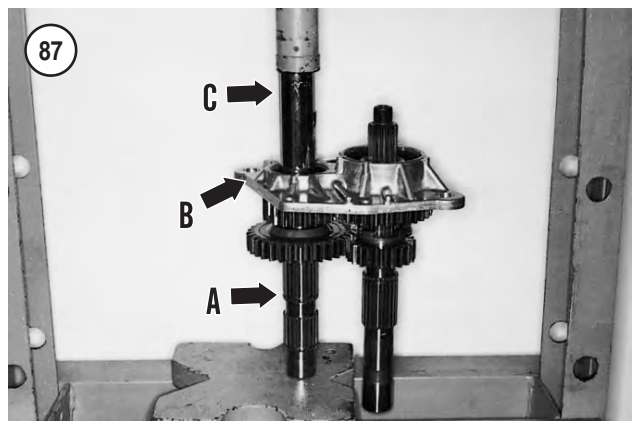
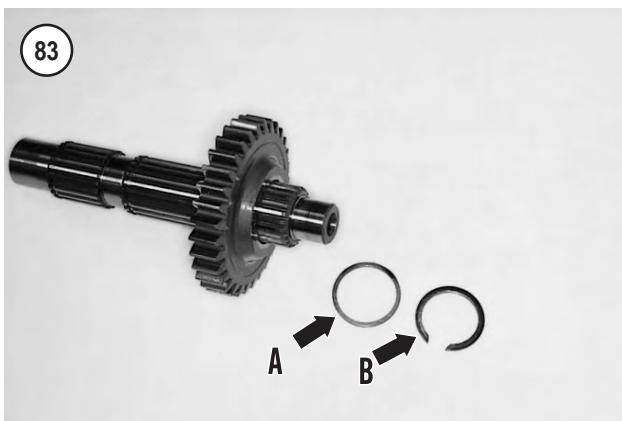
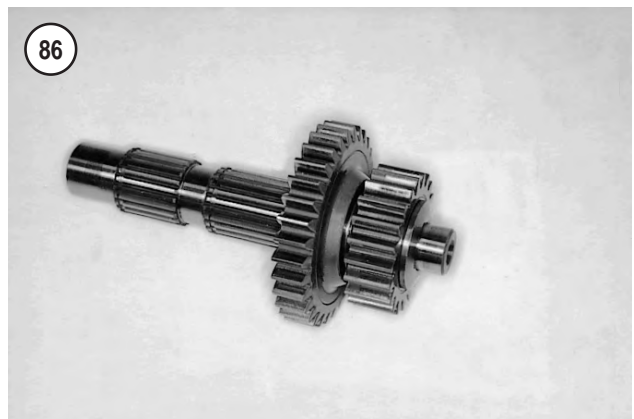
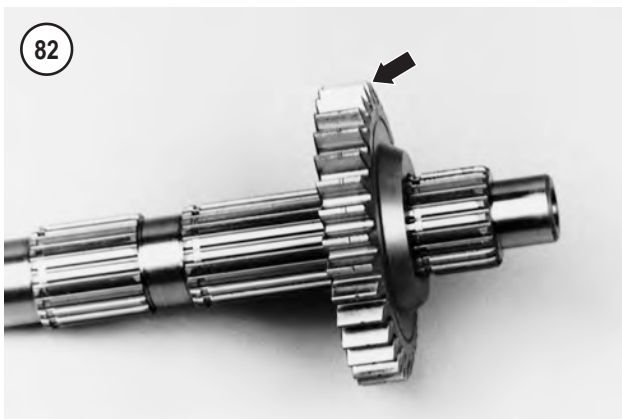
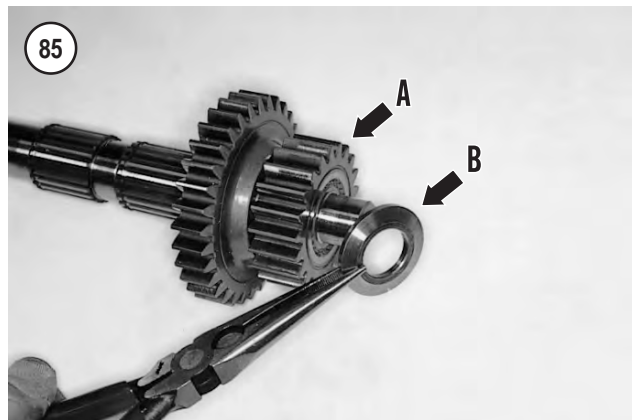

**CAUTION**

*The bearing driver must press against the inner bearing race or bearing damage will result.*

- c. Place a bearing driver (C, **Figure 87**) over the inner countershaft bearing race. Center the bearing driver underneath the press ram.
- d. Bring the press ram into position over the countershaft, checking that both shafts are straight up and that both gear sets are properly meshed, then press the bearing onto the countershaft until the beveled spacers bottom out against the bearing.

**Table 1 TRANSMISSION SPECIFICATIONS**

<b>Primary drive sprockets (engine-to-transmission)</b>	
Number of gear teeth	
Engine sprocket	35
Clutch sprocket	56
Ratio	1.60:1
<b>Final drive sprockets</b>	
<b>(transmission-to-rear wheel)–1991-1992 models</b>	
Number of sprocket teeth	
Transmission sprocket	
Chain drive	21
Belt drive	
883 models	27
1200 models	29
Rear wheel sprocket	
Chain drive	48
Belt drive	61
Ratio	
883 Standard and Hugger models	2.29:1
883 Deluxe models	2.26:1
1200 models	2.10:1
<b>Secondary drive belt</b>	
Number of teeth	
883 Deluxe models	
1991 models (yellow color code)	127
1992-2003 models (orange color code)	128
1200 models (orange color code)	128
<b>Final drive sprockets</b>	
<b>(transmission-to-rear wheel)–1993-2003 models</b>	
Number of sprocket teeth	
Transmission sprocket	
883 models	27
1200 models	29
Rear wheel sprocket	
61	
Ratio	
883 models	2.26:1
1200 models	2.10:1
<b>Overall gear ratios (U.S. models)</b>	
<b>1991-1992 883 Standard and Hugger models</b>	
1st	10.16
2nd	7.41
3rd	5.44
4th	4.45
5th	3.66
<b>1991-1992 883 Deluxe and all 1993-1994 883 models</b>	
1st	10.04
2nd	7.32
3rd	5.38
4th	4.39
5th	3.61
<b>1995-2003 883 models</b>	
1st	9.71
2nd	7.12
3rd	5.18
4th	4.26
5th	3.61
<b>1991-1994 1200 models</b>	
1st	9.35
2nd	6.82
3rd	5.01
4th	4.09
5th	3.36
<b>1995-2003 1200 models</b>	
1st	9.04
2nd	6.62
3rd	4.82
4th	3.97
5th	3.36

(continued)

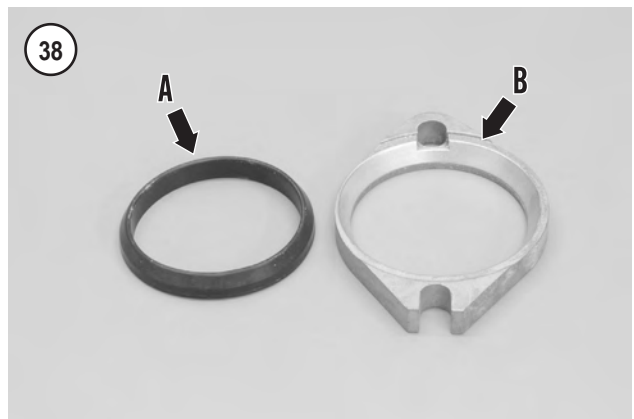
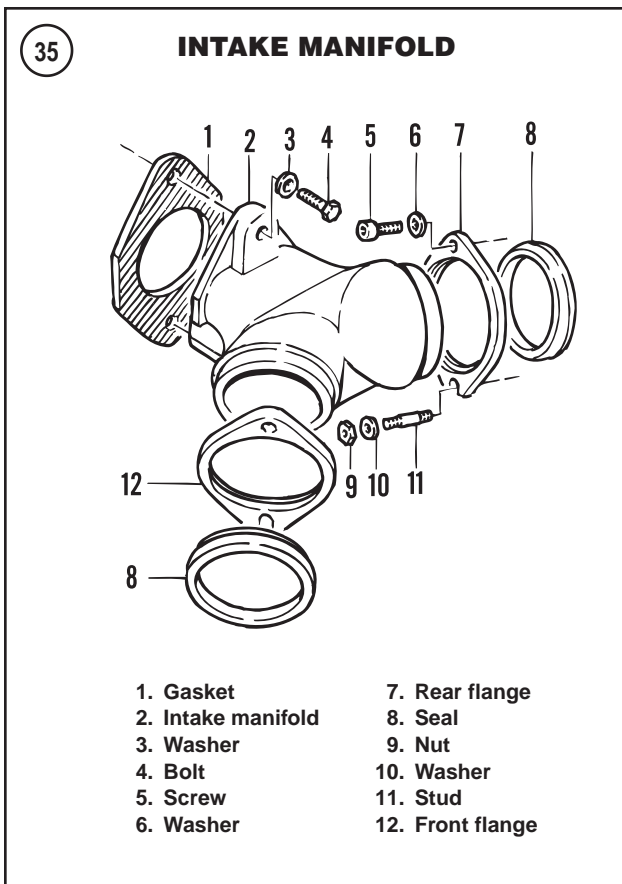
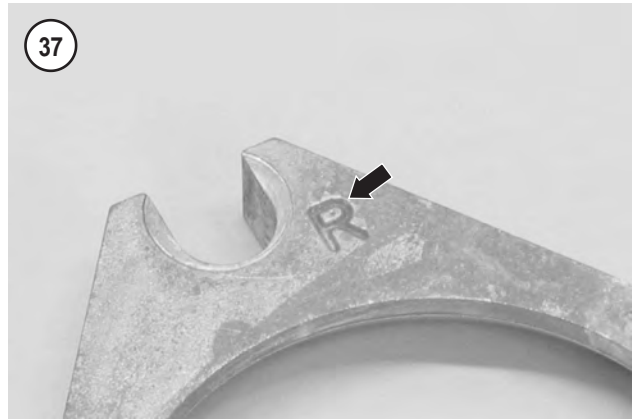

10

2. Remove the bolts and nuts securing the intake manifold (Figure 36) to the cylinder heads.

*NOTE*

*The front and rear intake manifold flanges are different. If the flanges are not marked (Figure 37), label them with an F and R to re-install them in the correct location.*

3. Remove the intake manifold, flanges and manifold seals.

4. Inspect the intake manifold. Inspect the intake manifold seals (A, Figure 38) for wear, deterioration or other damage. Replace the seals as a set if necessary.

5. Install the carburetor and spacer on the intake manifold. Tighten the intake manifold-to-carburetor mounting bolts to 180-204 in.-lb. (20-23 N•m).

6. Install the flanges and seals onto the intake manifold. Note that the seals (A, Figure 38) and flanges (B) have a tapered side. Fit the seal taper into the flange taper. Be sure the correct flange (F or R) is located at the front or rear of the manifold.

7. Install the intake manifold onto the cylinder head intake ports. The slotted ends of the flanges must point to the left.

8. Make sure the front and rear seals seat squarely against the cylinder head mating surfaces.

9. Install the intake manifold mounting bolts and nuts. Tighten the bolts and nuts to 72-120 in.-lb. (8-14 N•m).

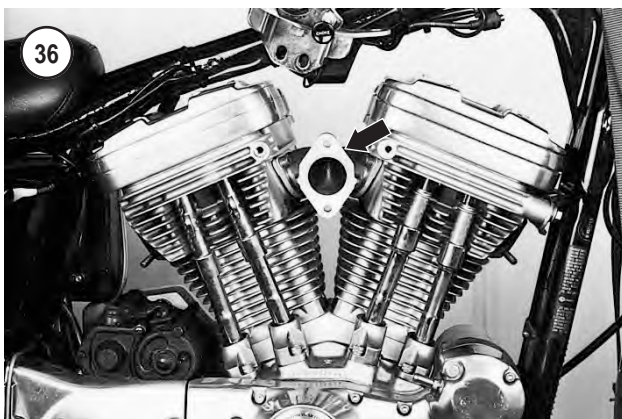

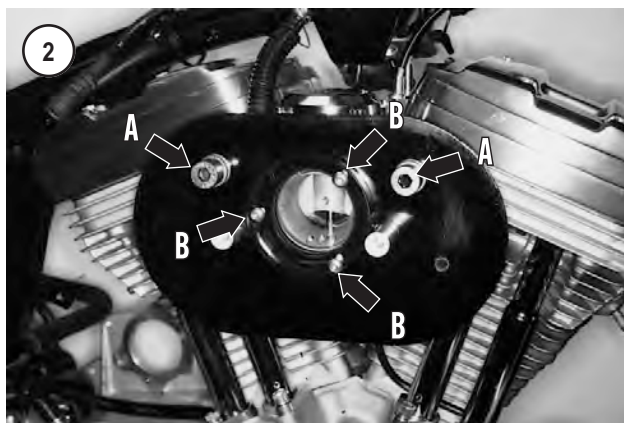
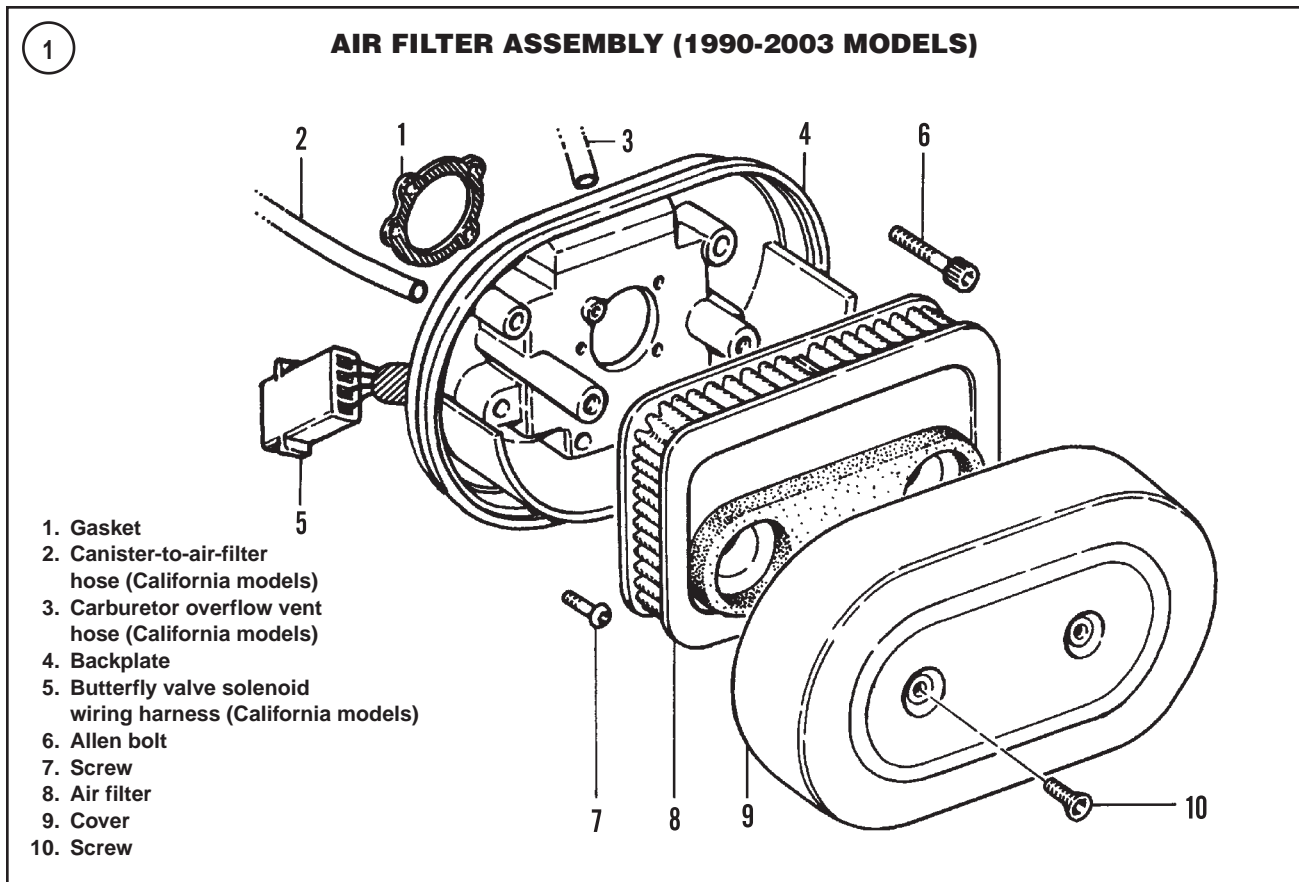

the main jet and needle jet. The tapered needle increases the effective flow capacity of the needle jet as it is lifted, and occupies progressively less of the area of the jet. At full throttle, the carburetor venturi is fully open and the needle is lifted far enough to permit the main jet to flow at full capacity.

The choke circuit is a starting enrichment valve system. The choke knob under the fuel tank on the left side of the engine opens an enrichment valve. In the open position, the slow jet discharges a stream of fuel into the carburetor venturi enriching the mixture when the engine is cold.

The accelerator pump circuit reduces engine hesitation by injecting a fine spray of fuel into the carburetor intake passage during sudden acceleration.



#### Removal/Installation

1. Remove the air filter (Chapter Three).
2. Remove the air filter backplate as described in this chapter.
3. Turn the fuel valve off.

*NOTE*

*It is easier to remove the enricher cable while it is attached to the carburetor.*

4. Remove the enricher bracket mounting screw (**Figure 3**) and allow the bracket to rest on top of the intake manifold.

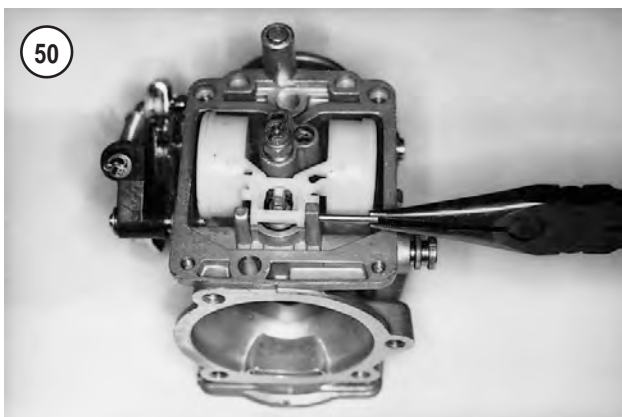
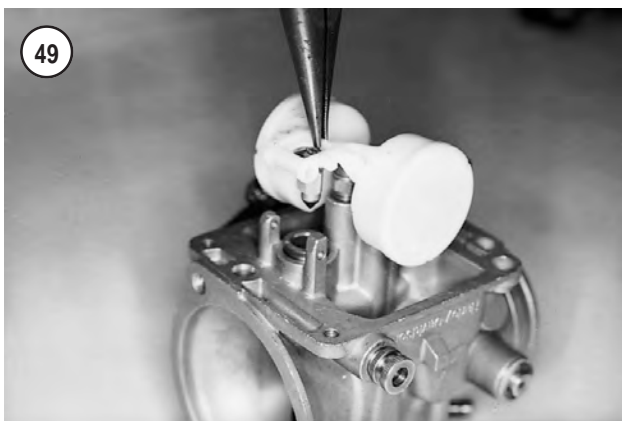
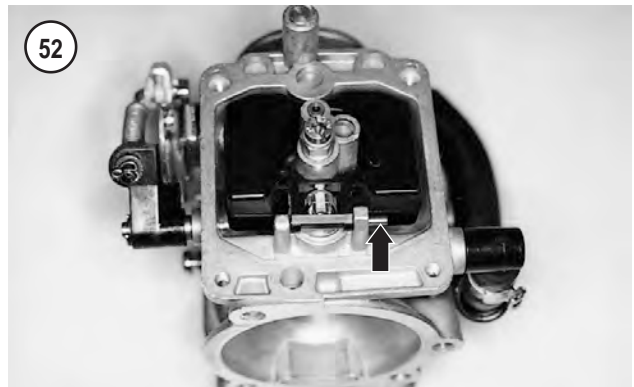
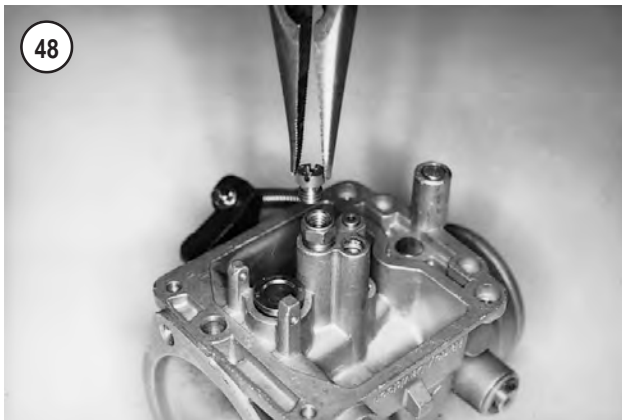
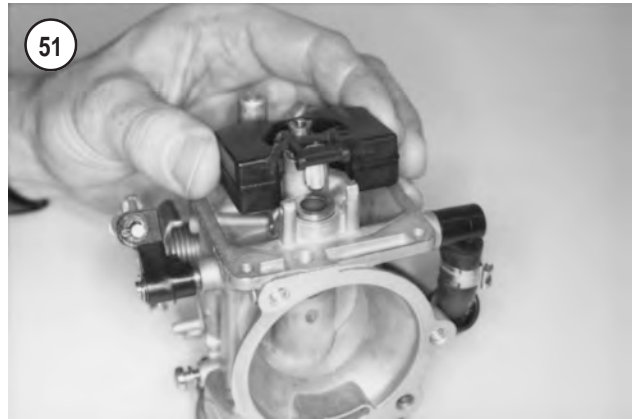
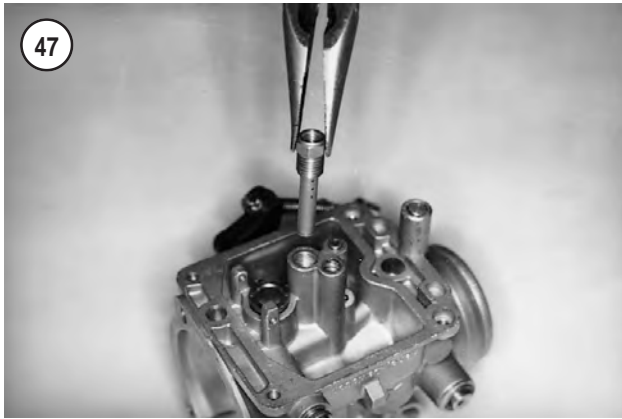

**NOTE**

*Before installing new jets, check the jet size and compare it to the old jet. Refer to **Table 1** for original equipment jet sizes.*

2. Place the pilot jet (**Figure 45**) into the passage and tighten it with the same screwdriver used during removal.
3. The needle jet has two different sides and can be installed incorrectly. Install the needle jet into its passage (**Figure 46**) so that the end with the larger opening faces up toward the vacuum piston chamber.
4. Install the needle jet holder (**Figure 47**) into the main jet passage and tighten it securely.
5. Install the main jet (**Figure 48**) onto the end of the needle jet holder and tighten securely.
- 6A. On 1988-1991 models, install the float as follows:
  - a. Install the fuel valve onto the float (**Figure 49**) and position the float onto the carburetor so the valve drops into its seat.
  - b. Align the float pivot arm with the two carburetor mounting posts and slip the pin through the float pivot arm and mounting posts (**Figure 50**).
- 6B. On 1992-2003 models, install the float as follows:
  - a. Install the fuel valve onto the float (**Figure 51**) and position the float onto the carburetor so that the valve drops into its seat.
  - b. Align the float pivot arm with the two carburetor mounting posts and slip the pin through the float pivot arm and mounting posts (**Figure 52**).

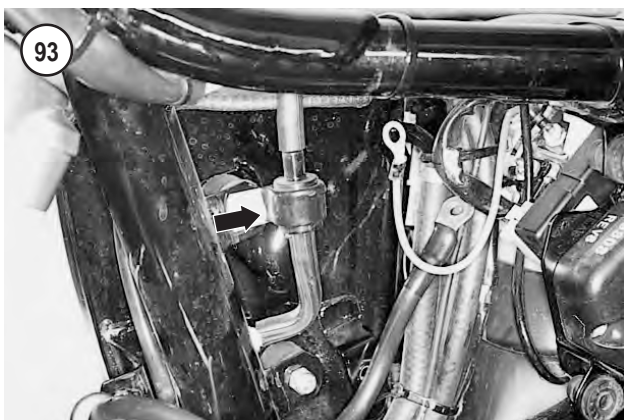

to the standpipe nozzle (**Figure 92**) at the bottom of the tank. This tube is routed along the frame and connected to a vapor valve (**Figure 93**) mounted to the frame and located between the battery and oil tank.

- a. On non-California models, a hose connected to the bottom of the vapor valve connects to a fitting in the hollow frame member.
- b. On California models, a hose connected to the bottom of the vapor valve connects to the carbon canister.

**Removal/Installation**

**WARNING**

*Some fuel may spill from the fuel tank hose during this procedure. Because gasoline is*

*extremely flammable and explosive, perform this procedure away from all open flames, including appliance pilot lights, and sparks. Do not smoke or allow anyone to smoke in the work area, as an explosion and fire may occur. Always work in a well-ventilated area. Wipe up any spills immediately.*

**WARNING**

*Make sure the fuel tank vapor hoses are routed in such a way that they cannot contact any hot engine or exhaust component. These hoses contain flammable vapors.*

**CAUTION**

*When removing the fuel tank in the following procedure, keep track of all fasteners and rubber bushings so they may be installed into their original mounting positions. Incorrect fastener assembly can cause tank damage.*

Refer to **Figure 94** or **Figure 95**.

1. Disconnect the negative battery cable (Chapter Twelve).
- 2A. On 1988-1994 models, drain the fuel tank as follows:
  - a. Turn the shutoff valve to off.
  - b. Disconnect the fuel supply hose (**Figure 96**) from the fuel shutoff valve.
  - c. Connect a longer hose to the shutoff valve fitting and place the open end of the hose into a gas can.
  - d. Turn the shutoff valve to reserve and drain the fuel into the tank. Account for the fuel line insulator.
- 2B. On 1995-2003 models, drain the fuel tank as follows:

**NOTE**

*A vacuum-operated fuel valve is installed on all models. A hand-operated vacuum pump is required to drain the fuel tank.*

- a. Turn the shutoff valve to off.
- b. Connect the drain hose to the fuel valve and secure it with a hose clamp. Insert the end of the drain hose into a gas can.
- c. Disconnect the vacuum hose from the fuel valve.
- d. Connect a hand-operated vacuum pump to the fuel valve vacuum hose fitting.
- e. Turn the fuel valve to the reverse position.

**CAUTION**

*Do not apply more vacuum than 25 in. (635 mm) Hg or the fuel valve diaphragm will be damaged.*

- f. Operate the vacuum pump handle and apply a maximum of 25 in. (635 mm) Hg of vacuum. Once the vacuum is applied, the fuel will start to flow into the gas can.
- g. When fuel stops flowing through the hose, turn the fuel valve off and release the vacuum. Disconnect the vacuum pump and drain hose.

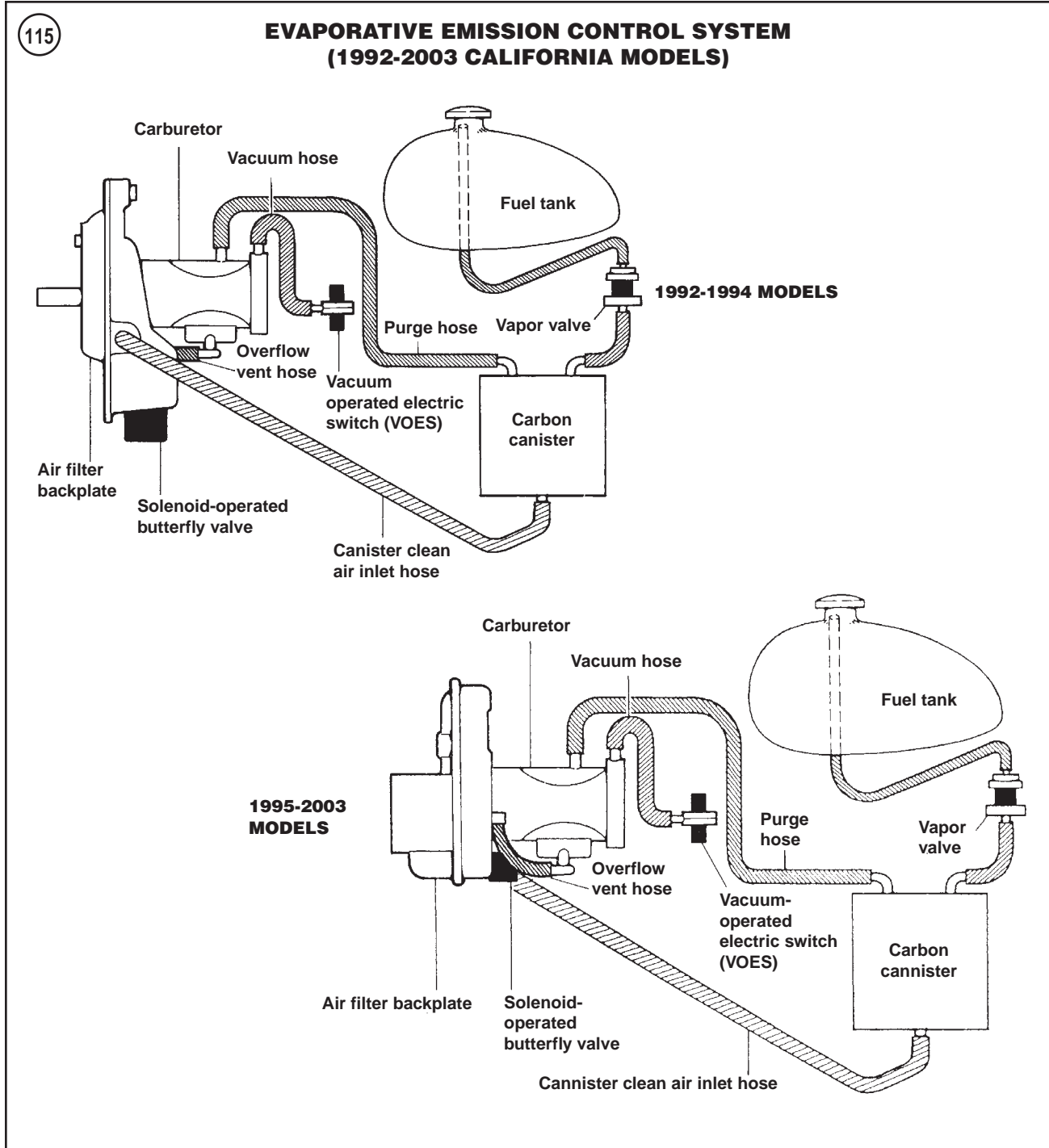

3. Note that one end of the vapor valve is longer than the other end. The longer end must point up when the vapor valve is installed on the motorcycle. Remove and replace the vapor valve.

**CAUTION**

*The vapor valve must be installed in a vertical position with the longer end pointing up or excessive pressure will build in the fuel tank.*

4. Install by reversing the removal steps.

**Carbon Canister Replacement**

Refer to **Figure 117** or **Figure 118**.

The carbon canister is mounted on the bottom side of the swing arm.

1. Remove the canister guard mounting screws and remove the guard.
2. On 1990-2003 models, cut the canister cable strap. Discard the strap.
3. Label and then disconnect the hoses from the canister. Plug the open end of each hose to prevent contamination.

**Table 2 FUEL SYSTEM TORQUE SPECIFICATIONS**

	<b>ft.-lb.</b>	<b>in.-lb.</b>	<b>N•m</b>
Air filter retaining screws (HDI models)	–	20	2
Backplate-to-carburetor screws	–	36-60	4-7
Backplate-to-cylinder head bolts	–	120-144	14-16
Fuel tank mounting bolts			
1988-1992 models	–	108	12
1993-2003 models	–	96-192	11-22
Intake manifold mounting bolts and nuts	–	72-120	8-14

**Table 3 EXHAUST SYSTEM TORQUE SPECIFICATIONS**

	<b>ft.-lb.</b>	<b>in.-lb.</b>	<b>N•m</b>
Cylinder head exhaust flange nuts	–	72-96	8-11
Front muffler locknut			
1991-1992 models	50-60	–	68-81
1993-2003 models	20-40	–	27-54
Muffler clamp nut			
1988-1993 models	–	84	9
Muffler mounting bolts	–	120-180	14-20
Rear master cylinder mounting bolts	–	155-190	18-21
Torca muffler clamp bolt			
1994-2003 models	35-40	–	48-54

If the motorcycle is not used for long periods of time, an automatic battery charger with variable voltage and amperage outputs is recommended for optimum battery service life.

**WARNING**

*During charging, explosive hydrogen gas is released from the battery. Only charge the battery in a well-ventilated area away from open flames, including pilot lights on appliances. Do not allow smoking in the area. Never check the charge of the battery by arcing across the terminals; the resulting spark can ignite the hydrogen gas.*

**CAUTION**

*Always disconnect the battery cables from the battery. If the cables are left connected during the charging procedure, the charger may damage the diodes within the voltage regulator/rectifier.*

1. Remove the battery from the motorcycle as described in this section.
2. Set the battery on a stack of newspapers or shop cloths to protect the surface of the workbench.
3. Make sure the battery charger is turned off prior to attaching the charger leads to the battery.
4. Connect the positive charger lead to the positive battery terminal and the negative charger lead to the negative battery terminal.
5. Set the charger at 12 volts. If the output of the charger is variable, select the low setting.
6. The charging time depends on the discharged condition of the battery. Refer to **Table 2** for the suggested charging time. Normally, a battery should be charged at 1/10 its given capacity.

**CAUTION**

*If the battery emits an excessive amount of gas during the charging cycle, decrease the charge rate. If the battery becomes hotter than 110° F (43° C) during the charging cycle, turn the charger off and allow the battery to cool. Then continue with a reduced charging rate and continue to monitor the battery temperature.*

7. Turn the charger on.
8. After the battery has been charged for the predetermined time, turn off the charger, disconnect the leads and measure the battery voltage. Refer to the following:
  - a. If the battery voltage is 13.0-13.2 volts at 68° F (20° C), the battery is fully charged.
  - b. If the battery voltage is 12.5 volts at 68° F (20° C), or lower, the battery is undercharged and requires additional charging time.
9. If the battery remains stable for one hour, the battery is charged.

10. Install the battery into the motorcycle as described in this section.

**Initialization**

A new battery must be fully charged before installation. To bring the battery to a full charge, give it an initial charge. Using a new battery without an initial charge will cause permanent battery damage. The battery will never be able to hold more than an 80% charge. Charging a new battery after it has been used will not bring its charge to 100%. When purchasing a new battery, verify its charge status.

**NOTE**

*Recycle the old battery. When a new battery is purchased, turn in the old one for recycling. Most motorcycle dealerships will accept the old battery in trade for a new one. Never place an old battery in the household trash since it is illegal, in most states, to place any acid or lead (heavy metal) contents in landfills.*

**Load Testing**

A load test checks battery performance under full current load and is the best indication of battery condition.

A battery load tester is required for this procedure. When using a load tester, follow the manufacturer's instructions.

1. Remove the battery from the motorcycle as described in this chapter.

**NOTE**

*Let the battery stand for at least one hour after charging prior to performing this test.*

2. The battery must be fully charged before beginning this test. If necessary, charge the battery as described in this section.

**WARNING**

*The battery load tester must be turned off prior to connecting or disconnecting the test cables to the battery. Otherwise, a spark could cause the battery to explode.*

**CAUTION**

*To prevent battery damage during load testing, do not load test a discharged battery and do not load test the battery for more than 20 seconds. Performing a load test on a discharged battery can cause permanent battery damage.*

3. Load test the battery as follows:
  - a. Connect the load tester cables to the battery following the manufacturer's instructions.



14. Before riveting the cover in place, check the ignition timing as described in Chapter Three.

**CAUTION**

*Be sure to use the correct rivets when installing the inner and outer covers. These are timing cover rivets which do not have ends that will fall into the timing compartment and damage the ignition components.*

15. Rivet the outer cover to the inner cover. Only use original equipment rivets (part No. 8699) to secure the outer cover. See **Figure 51** and **Figure 43**.



**Inspection**

1. If necessary, refer to Chapter Two for troubleshooting.
2. Check the ignition compartment for oil leaks. If present, remove the gearcase oil seal (B, **Figure 50**) by prying it out with a screwdriver or seal remover. Install a new seal by tapping it in place with a suitable size socket placed on the outside of the seal. Drive the seal into position so it is flush with the seal bore surface. If the gearcase oil seal is not seated properly, it will leak.

**Ignition Module Removal/Installation**

The ignition module (**Figure 52**) is mounted on the left side of the motorcycle to the rear of the battery.

1. Disconnect the negative battery cable as described in this chapter.
2. Remove the ignition module cover.
- 3A. On 1986-1994 models, disconnect the ignition module wires from the ignition coil. Remove the ground wire connection at the frame.
- 3B. On 1995-1997 models, disconnect the ignition module connector from the wiring harness.
4. Remove the ignition module assembly (**Figure 52**).
5. Install by reversing the preceding steps. On 1995-1997 models, tighten the ignition module bolts to 15-20 in.-lb. (1.5-2 N•m).

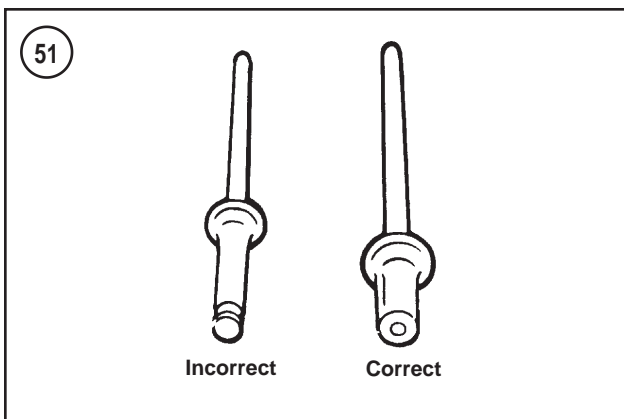

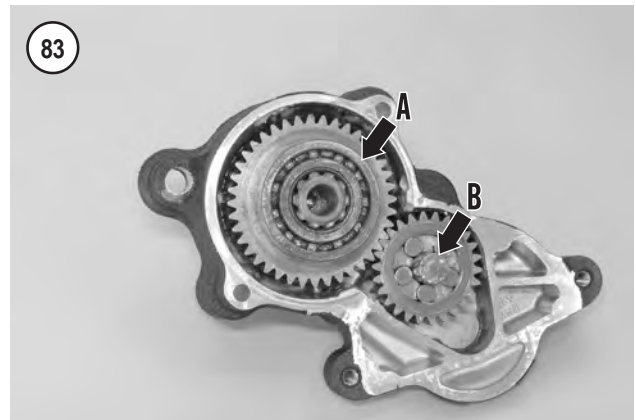
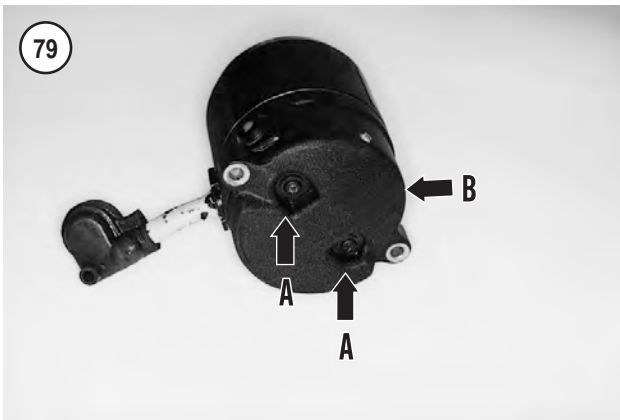
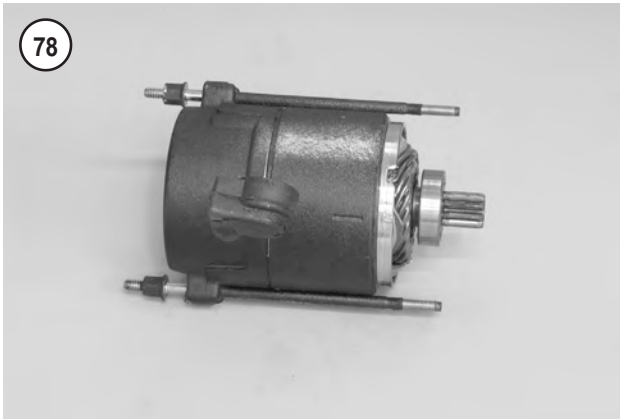

5. Remove the two screws (A, **Figure 79**) securing the end cover to the brush holder. Remove the end cover (B).
6. Lift the field coil brush springs out of their holders with a small hook and remove the brushes from their holders.
7. Slide the brush holder (**Figure 80**) off the commutator.
8. Separate the armature (**Figure 81**) from the field coil assembly.
9. Remove the drive housing mounting screws (**Figure 82**).
10. Tap the drive housing and separate it from the starter (**Figure 83**).
11. Remove the ball and spring (**Figure 84**) from the solenoid housing.

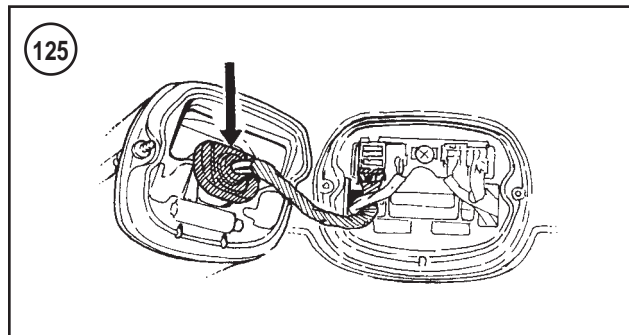
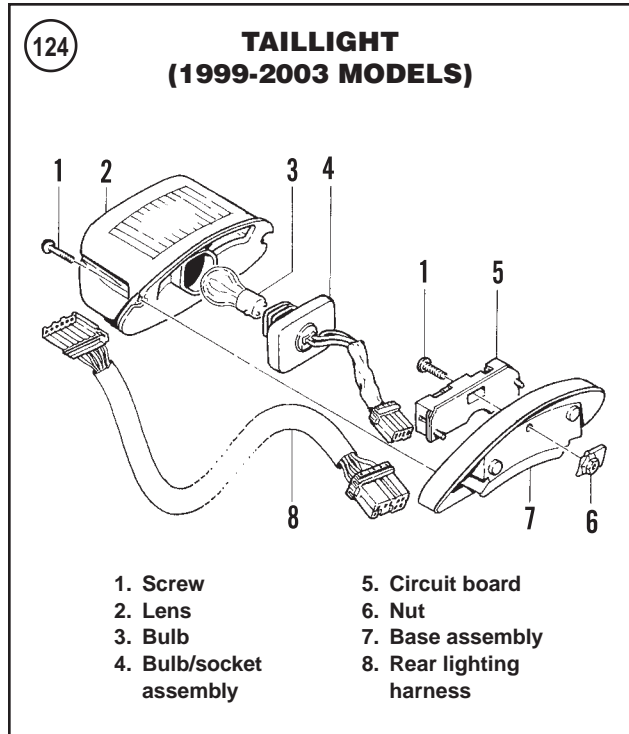

### Taillight/Brake Light Replacement

#### 1986-1998 models

#### WARNING

*Make sure the taillight and brake light operate correctly before operating the motorcycle.*

1. Remove the two mounting screws and remove the lens assembly (**Figure 122**) from the taillight base.
2. Push in the bulb (**Figure 123**), turn the bulb one-quarter turn counterclockwise and remove the bulb from the socket.
3. Replace the lens gasket if torn or damaged.
4. Install the bulb and lens.

#### 1999-2003 models

Refer to **Figure 124**.

1. Remove the two mounting screws and remove the lens assembly from the taillight base.
2. Pull the bulb socket (**Figure 125**) from the lens.

		IGNITION SWITCH (TYPICAL)		
		Red/black	Red	Red/gray
Position \ Switch	Off		•	
	Accessory		•—————•	•—————•
	Ignition	•—————•	•—————•	•—————•



3. Detach all connectors located between the switch and the electrical circuit.

#### CAUTION

*Do not attempt to start the engine with the battery disconnected.*

4. When separating two connectors, pull on the connector housings and not the wires.

5. After locating a defective circuit, check the connectors to make sure they are clean and properly connected. Check all wires going into a connector housing to make sure each wire is positioned properly and the wire end is not loose.

6. To reconnect connectors properly, push them together until they click or snap into place.

### Handlebar Switches (1986-1995 Models)

#### Left handlebar switch description

The left side handlebar switch housing (Figure 149) is equipped with the following switches:

1. Headlight dimmer.
2. Horn.
3. Left side turn signal.

#### Right handlebar switch description

The right side handlebar switch housing (Figure 150) is equipped with the following switches:

1. Engine stop/run.
2. Start.
3. Right side turn signal.
4. Front brake light.

#### Handlebar switch replacement

1. Remove the screws securing the left handlebar switch housing. Separate the switch housing (Figure 151) to access the switches (Figure 152).

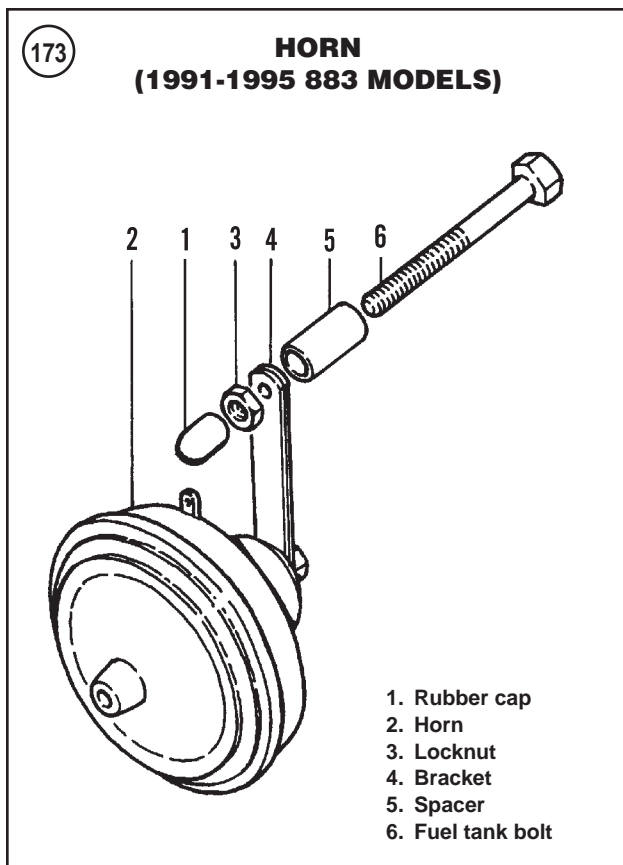

### Removal/Installation

#### 1986-1995 883 models

Refer to **Figure 172** or **Figure 173**.

1. Label and then disconnect the horn electrical connector(s) at the horn spade terminals.
2. Remove the rubber cap from the front fuel tank mounting bolt.
- 3A. On 1986-1990 models, remove the front fuel tank mounting bolt.
- 3B. On 1991-1995 models, hold the front fuel tank mounting bolt and remove the horn locknut.
4. Remove the horn, bracket and spacer.
5. Install by reversing the preceding removal steps while noting the following:
  - a. Make sure the electrical connectors and horn spade terminals are free of corrosion.
  - b. Tighten the front fuel tank mounting bolt to the tightening torque specified in **Table 4**.
  - c. Check that the horn operates correctly.

#### 1986-1990 1100 and 1200 models

Refer to **Figure 174**.

1. Label and then disconnect the horn electrical connectors at the horn spade terminals.
2. Disconnect the ground strap from the support bracket.
3. Remove the bolt (4, **Figure 174**), then remove the horn assembly.
4. Remove the nut (10, **Figure 174**) and separate the horn and cover.
5. Install by reversing the removal steps. Note the following:
  - a. Make sure the electrical connectors and horn spade terminals are free of corrosion.
  - b. Check that the horn operates correctly.

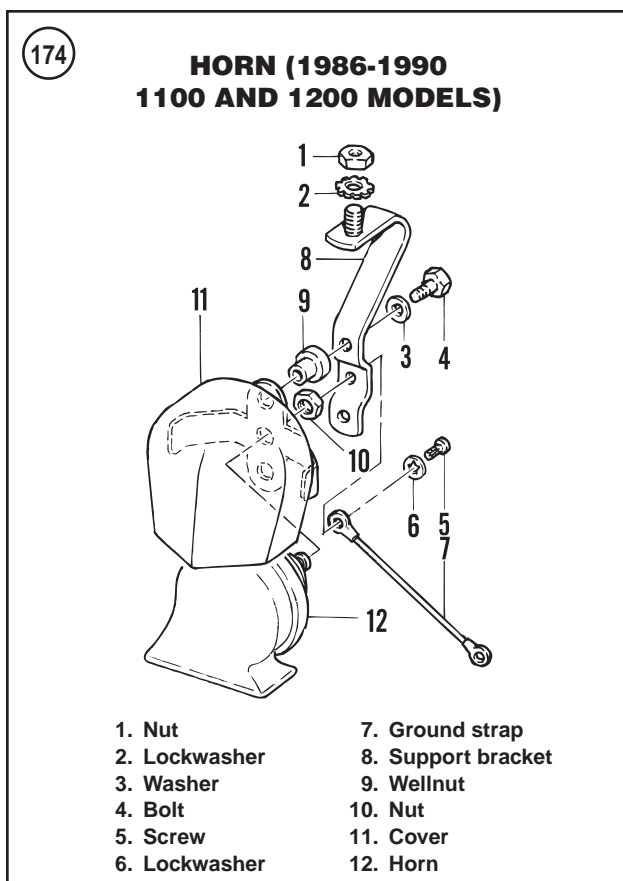

#### All 1991-2003 1200 models except 1200C models

Refer to **Figure 175**.

1. Label and then disconnect the horn electrical connectors at the horn spade terminals.
2. Remove the Acorn nut and lockwasher securing the horn assembly to the rubber mount stud.
3. Remove the horn assembly and remove the wire clip from the backside of the horn bracket.
4. Remove the locknut from the recess in the horn bracket. Then remove the horn and tooth lockwasher.
5. Install by reversing the preceding removal steps while noting the following:
  - a. Make sure the electrical connectors and horn spade terminals are free of corrosion.
  - b. Check that the horn operates correctly.

200

**AMP MULTILOCK CONNECTORS**

3-pin connector

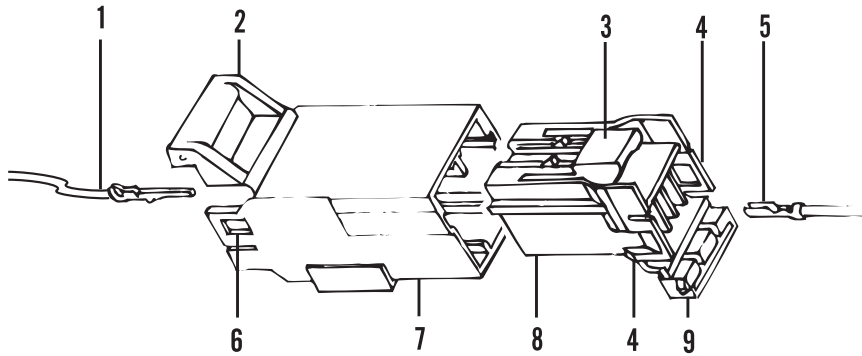

6-pin connector

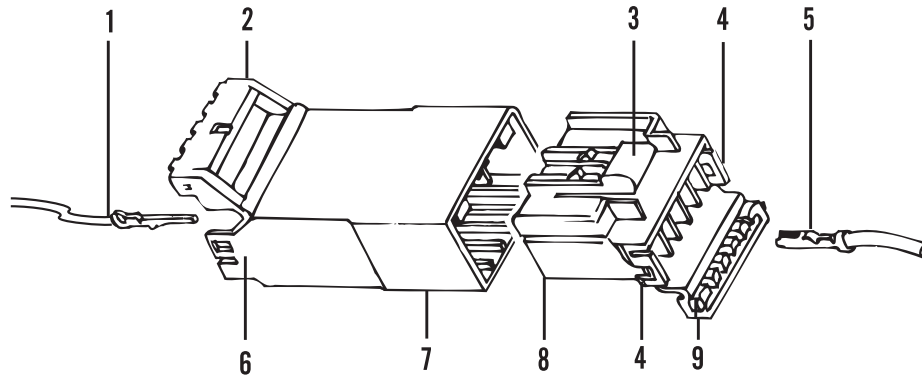

10-pin connector

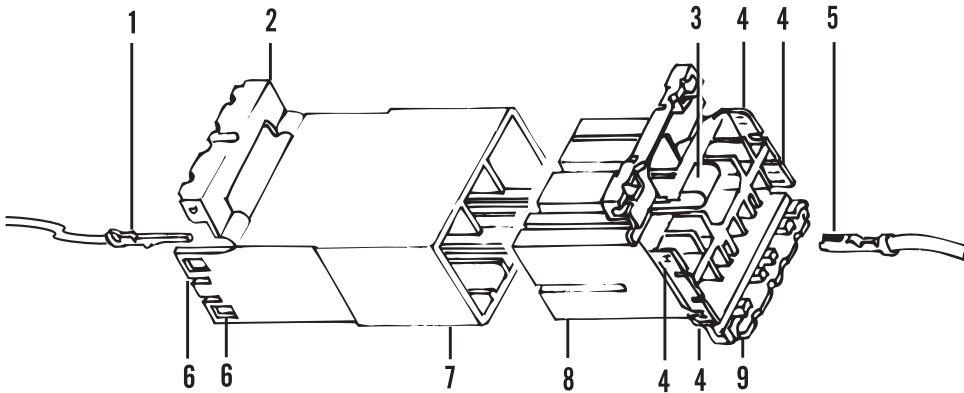

- 1. Pin terminal
- 2. Secondary lock
- 3. Button
- 4. Latch
- 5. Socket terminal
- 6. Latch
- 7. Pin housing
- 8. Socket housing
- 9. Secondary lock

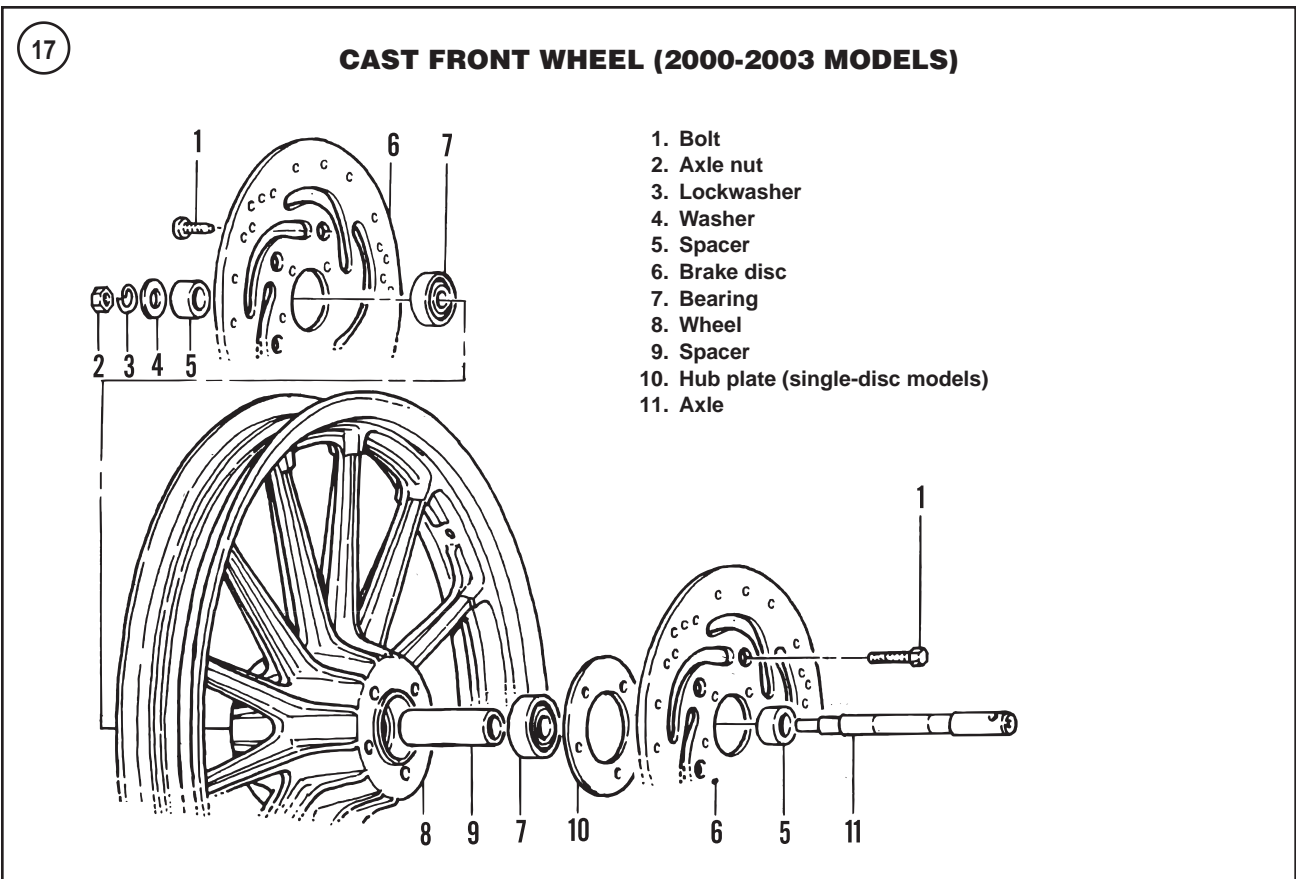
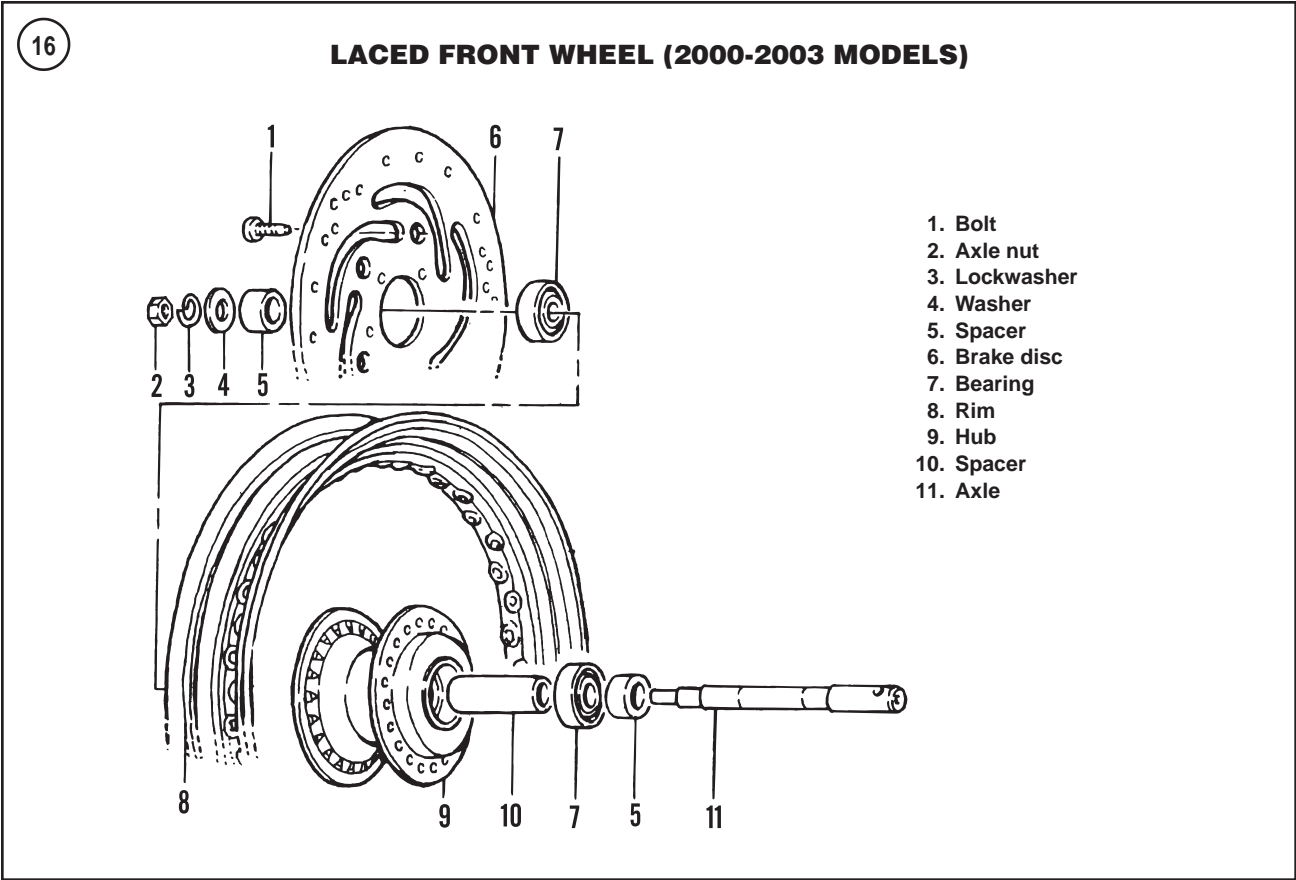

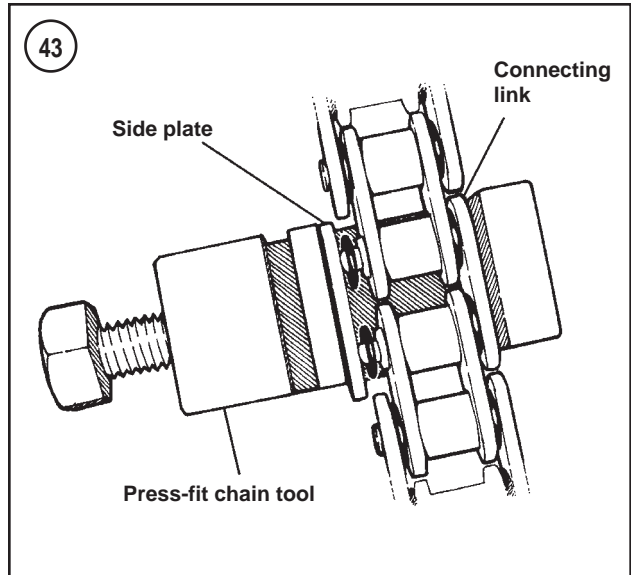
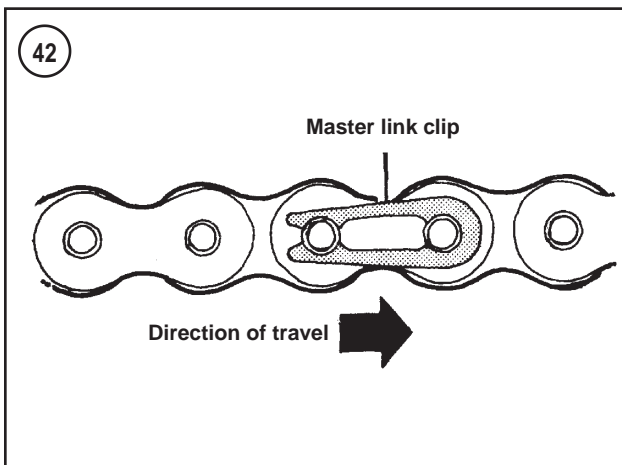
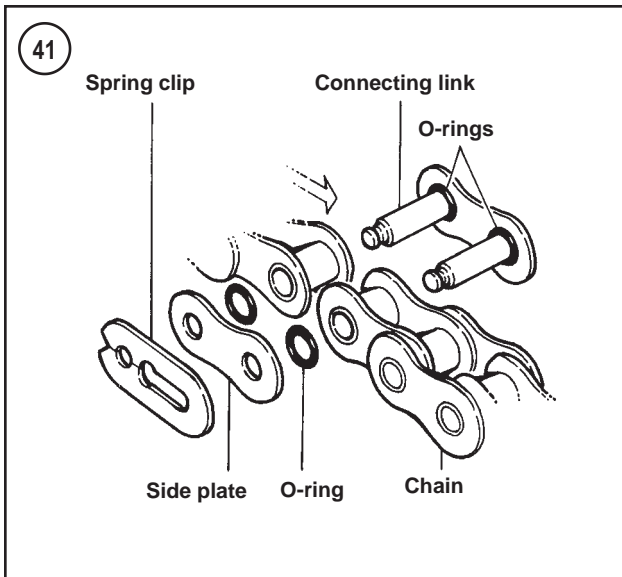

- b. If assembling the chain using a press fit master link, refer to *Press Fit Master Link* in this section to press the side plate onto the connecting link.
- c. Install the spring clip onto the master link so the closed end of the clip faces the direction of chain travel (**Figure 42**).
- d. Lubricate and adjust the drive chain as described in Chapter Three.

**Press Fit Master Link**

**CAUTION**

*Attempting to install a press-fit master link without the proper tools can damage the master link and parts of the chain.*

**NOTE**

*Most commercial press-fit chain tools are designed to press the side plate onto the connecting link to its correct depth. If the side plate is pressed on too far, it will bind the chain where it is joined at the master link. If the side plate is not pressed on far enough, the spring clip cannot be installed correctly and will probably come off. Properly installed, the side plate is flush with both pin seating grooves in the connecting link.*

- 7. If reusing the original chain, service it as required, then connect it to the old chain and pull it around the front sprocket. Disconnect the chains.
- 8. Install by reversing the preceding removal steps while noting the following:
  - a. On an O-ring chain, install the four O-rings onto the master link as shown in **Figure 41**, typical.

Many drive chains are equipped with a master link side plate that is pressed into place. To install this type of master link, a press-fit chain tool is required; **Figure 43** illustrates one type of chain press tool. To disconnect the chain, first remove the outer clip from the master link, then use a chain breaker to separate the side plate from the connecting link.

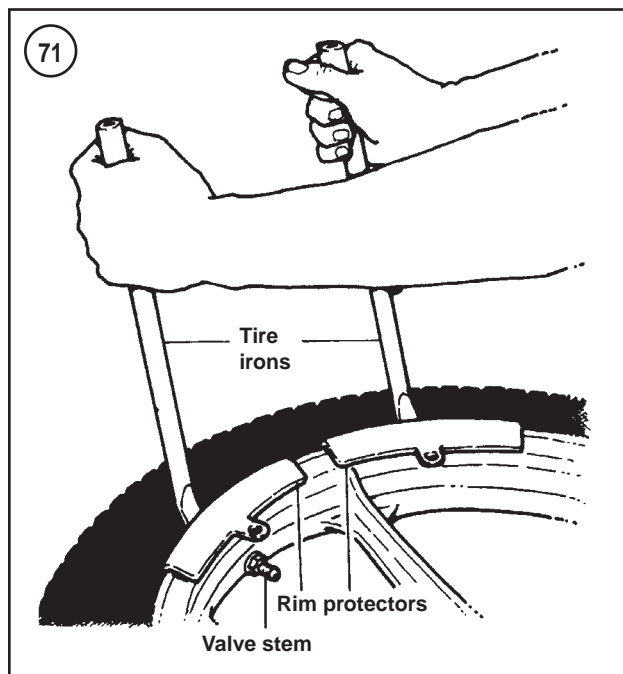
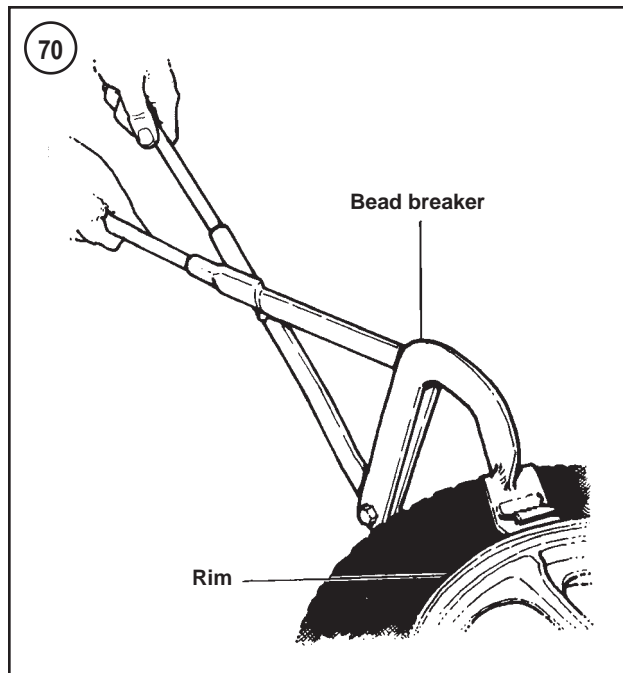

New tires provide significantly less adhesion until they are broken in. Do not subject new tires to high speed or high cornering forces for at least 60 mile (100 km). Be especially careful when encountering wet conditions with new tires.

### Removal

#### CAUTION

To avoid damage when removing the tire, support the wheel on two wooden blocks, so the brake disc or the driven sprocket does not contact the floor.

#### NOTE

To make tire removal easier, warm the tire to make it softer and more pliable. Place the wheel and tire assembly in the sun. If possible, place the wheel assembly and the new tire in a completely closed automobile parked in the sun.

Take special care with tire irons when changing a tire to avoid scratches and gouges to the outer rim surface. Insert pads between the tire iron and the rim to protect the rim from damage.

All original equipment cast or disc wheels are designed for use with tubeless tires only. All laced wheels use a tube and tire combination.

When removing a tubeless tire, take care not to damage the tire beads, inner liner of the tire or the wheel rim flange. Use tire levers or flat handle tire irons with rounded heads.

1. Remove the front or rear wheel as described in this chapter.
2. If not already marked by the tire manufacturer, mark the valve stem location on the tire, so the tire can be installed in the same location for easier balancing.
3. Remove the valve cap and unscrew the core from the valve stem and deflate the tire or tube.

#### CAUTION

The inner rim and tire bead areas are the sealing surfaces on tubeless tires. Do not scratch the inside of the rim or damage the tire bead.

#### NOTE

Removal of tubeless tires from their rims can be difficult because of the tight tire bead-to-rim seal. Breaking the bead seal may require a special tool (Figure 70). If unable to break the seal loose, take the wheel to a dealership and have them break it loose on a tire changing machine.

4. Press the entire bead on both sides of the tire away from the rim and into the center of the rim. If the bead is tight, use a bead breaker.
5. Lubricate both beads with soapy water.

#### CAUTION

Use rim protectors (Figure 71, typical) or insert scraps of leather between the tire iron and the rim to protect the rim from damage.

#### CAUTION

Use only tire irons without sharp edges. If necessary, file the ends of the tire irons to remove rough edges.

6. Insert a tire iron under the top bead next to the valve stem (Figure 72). Force the bead on the opposite side of the tire into the center of the rim and pry the bead over the rim with the tire iron.

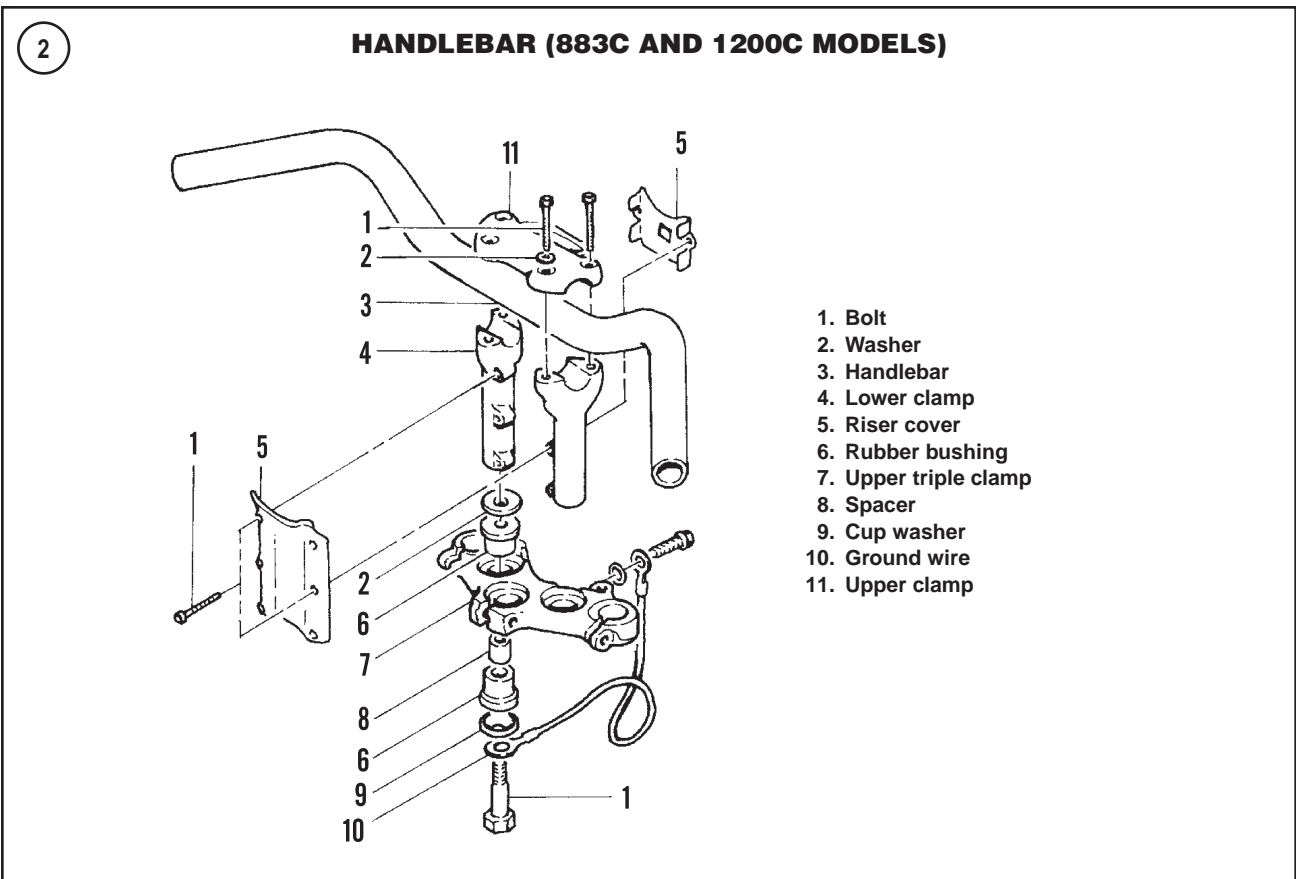
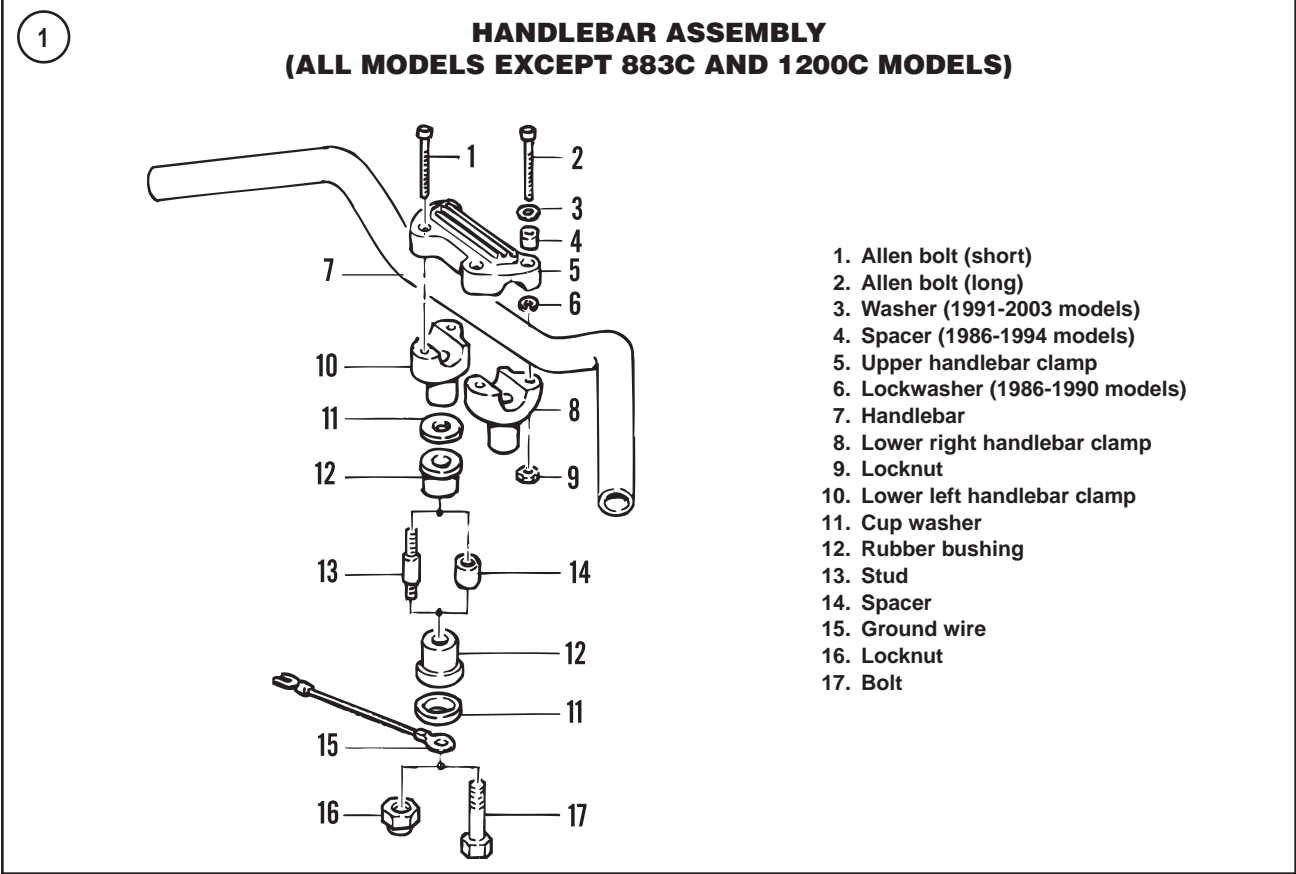

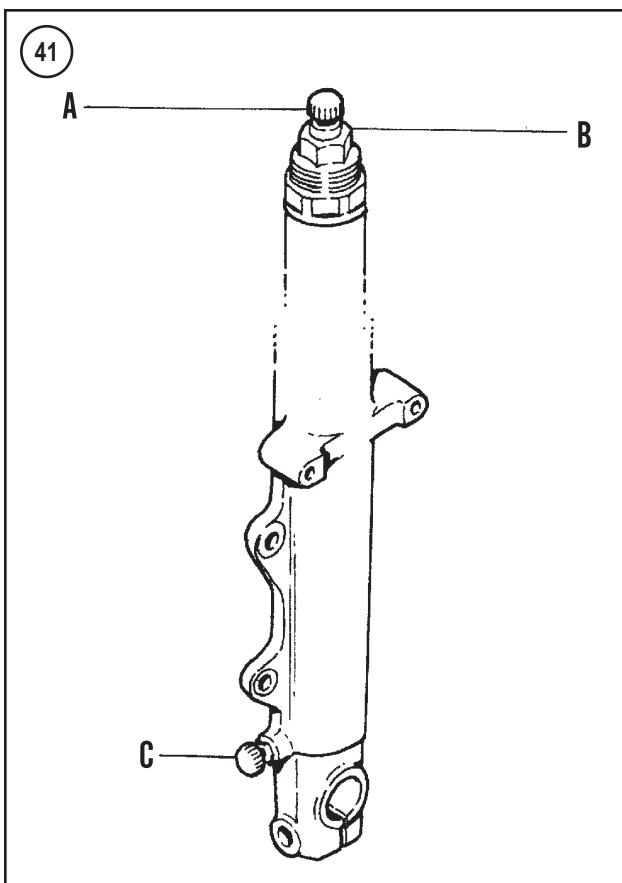
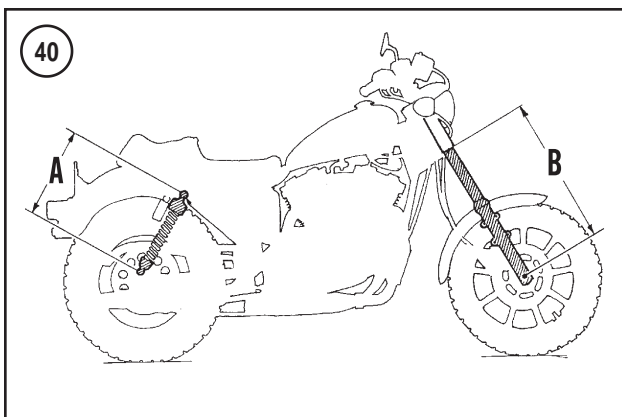

- a. The rear suspension length is the distance from the center of the upper shock nut to the center of the lower shock nut (A, **Figure 40**).
  - b. The front suspension length is the distance from the center of the front axle to the bottom of the lower triple clamp (B, **Figure 40**).
3. Load the full gear onto the motorcycle.
  4. Measure the rear-suspension length and front-suspension length of the loaded motorcycle.

**WARNING**

*Preload must be equal on both sides of the motorcycle. Set both rear shock-absorber preload cams to the same setting. Also set*

*both fork adjusting nuts to the same setting. Handling will be adversely affected if preload is not the same on both sides of the motorcycle.*

5. Subtract the loaded suspension length from the unloaded suspension length. The difference must be 0.5-1.0 inches (12.7-25.4 mm). Adjust the preload if the difference is not within the specification.

- a. To adjust the front preload, turn the preload adjuster (A, **Figure 41**) with a 7/8-in. wrench. Turning the nut clockwise increases front preload; counterclockwise decreases the preload.
- b. To adjust the rear preload, refer to *Shock Absorber* in Chapter Fifteen.

**Front fork damping adjustment**

The 1200S fork is adjustable for compression and rebound damping.

1. Adjust the preload as described in the *Suspension Preload Adjustment* in this section.

**WARNING**

*Compression and rebound damping settings must be equal on both sides of the motorcycle. Handling will be adversely affected if damping is not the same on both fork legs.*

2. The front fork on the 1200S has 14 compression damping settings. Setting 1 (fully clockwise) is the hardest; setting 14 (fully counterclockwise) is the softest. The recommended setting is 13 clicks from the hardest setting.

**NOTE**

*To ensure the desired results, do not adjust the damping more than two clicks without testing the setting.*

- a. Turn the compression damping adjuster (B, **Figure 41**) one or two clicks. Turning the adjuster clockwise increases compression damping, counterclockwise decreases compression damping.
  - b. Turn the compression damping adjuster on the other fork leg to the same setting.
  - c. Test ride the motorcycle.
  - d. Repeat the above steps until the desired compression damping is obtained.
3. The 1200S front fork has 15 rebound damping settings. Setting 1 (fully clockwise) is the hardest; setting 15 (fully counterclockwise) is the softest. The recommended setting is 8 clicks from the hardest setting.
    - a. Turn the rebound damping adjuster (C, **Figure 41**) one or two clicks. Turning the rebound adjuster clockwise increases rebound damping; counterclockwise decreases rebound damping.
    - b. Turn the rebound damping adjuster on the other fork leg to the same setting.

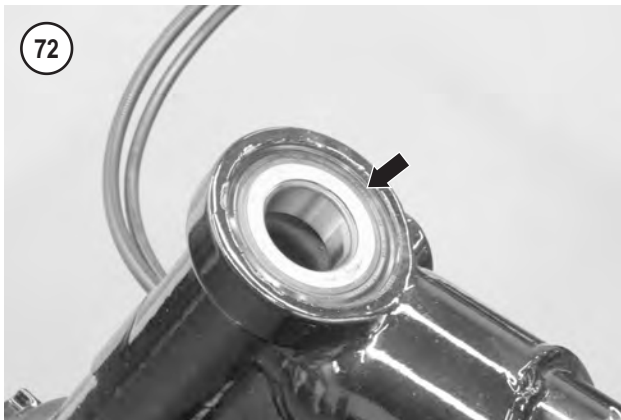
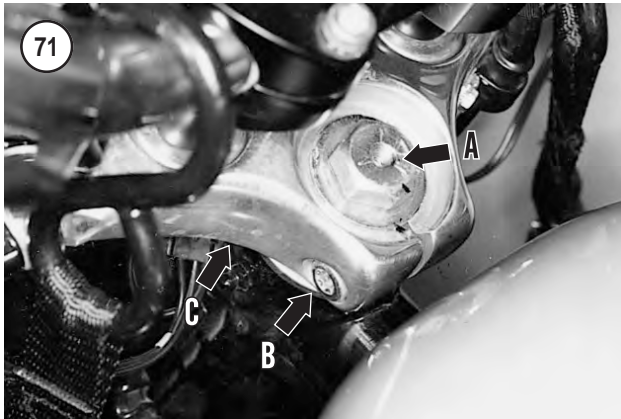

2. Clean the bearings in solvent to remove all of the old grease. Blow the bearing dry with compressed air, making sure not to allow the air jet to spin the bearing. Do not remove the lower bearing from the fork stem unless replacement is required; clean the bearing together with the steering stem.

3. After the bearings are dry, hold the inner race with one hand and turn the outer race with your other hand. Turn the bearing slowly, checking for roughness, looseness, trapped dirt or grit. Check the bearing (**Figure 75**) for pitting, scratches or visible damage. If the bearings are worn, check the dust covers for wear or damage or for improper bearing lubrication. Replace the bearing if necessary. Pack it with grease and wrap it with wax paper until it can be reinstalled. Do not store the bearings for any length of time without lubricating them or they will rust.

4. Check the steering stem for cracks or damage. Check the threads at the top of the stem for strippage or damage. Check the steering stem bolt or nut by threading it into the steering stem; make sure the bolt or nut threads easily with no roughness. If necessary, clean the threads carefully with a brush and solvent or use a tap or die of the correct thread type and size.

5. Worn or damaged parts should be replaced. When discarding a bearing, both bearings and their races should be replaced at the same time. Replace bearing races as described in this chapter.

6. Replace the lower steering stem bearing and dust cover as described in this chapter.

7. Check for broken welds on the frame around the steering head. If any are found, have them repaired by a frame shop.

### Installation

1. Make sure the steering head bearing races are properly seated as described in *Steering Head Bearing* in this chapter.

2. Wipe the bearing races with a clean lint-free cloth. Then lubricate each race with bearing grease.

3. Pack the upper and lower bearings with bearing grease. The lower bearing and lower dust shield should be installed on the steering stem prior to installing the steering stem in the steering head. If necessary, install the lower bearing as described in this chapter.

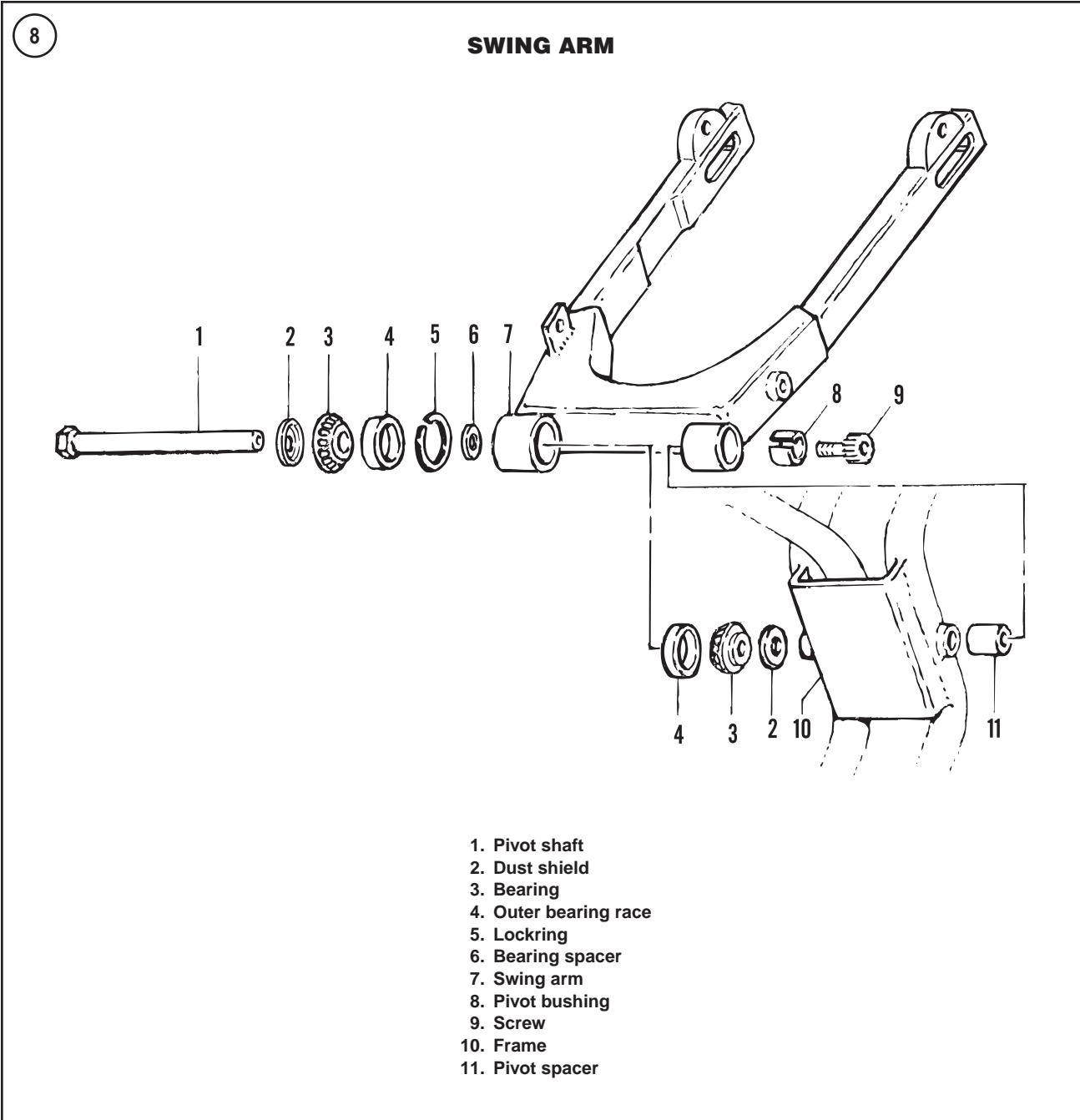

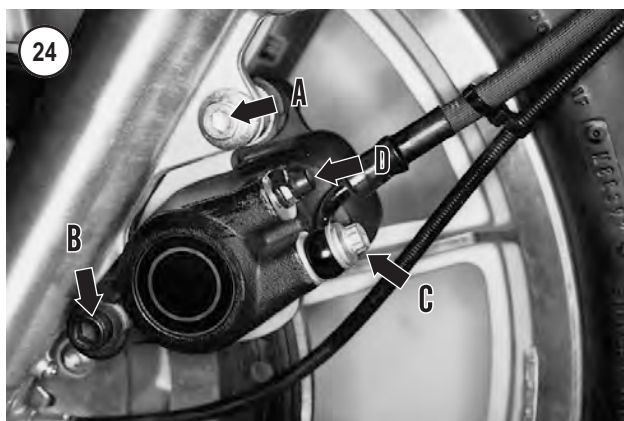
**CAUTION**

*Do not allow the pistons to travel out far enough to contact the brake disc. If this happens, the pistons may damage the disc during caliper removal.*

- b. Slowly apply the front brake lever to push the piston part way out of the caliper for ease of removal during caliper service.

3B. If caliper service is not required, insert a spacer between the brake pads (**Figure 25**) in the caliper. The spacer prevents the piston from being forced out of the caliper if the brake lever is squeezed while the caliper is removed from the brake disc. If the pistons are forced out, disassemble the caliper and reseat the pistons as described in this chapter.

**NOTE**

*If complete removal of the caliper is not necessary, suspend the caliper and disregard the remaining steps. Do not let the caliper hang from the brake line.*

4. Drain the brake fluid from the front brake hose as described in *Brake Hose and Line Replacement* in this chapter.
5. Remove the banjo bolt from the caliper (C, **Figure 24**). Remove the bolt and the two washers. Place the open hose end into a plastic bag to prevent spills and to keep out dirt.
6. Remove the caliper. Place it in a plastic bag until installation or disassembly.

**Installation****WARNING**

*The upper and lower caliper bushings must be installed in the fork slider prior to installing the brake caliper. Otherwise, the caliper and pad will be improperly located in relation to the brake disc. This condition will bind the caliper and brake pads, causing uneven braking and possible brake lockup.*

1. Make sure the upper and lower caliper bushings, installed in the fork slider, are in place (**Figure 26**, typical).
2. If removed, install the brake pads as described in this chapter.
3. Coat the lower mounting pin with high-temperature bearing/brake grease (Dow Corning Moly 44 or equivalent).
4. Align the two mounting holes in the caliper with the fork slider mounting lugs.
5. Install a washer onto the upper mounting screw and insert the screw (A, **Figure 24**) through the slider lug and then thread into the caliper bushing. Install the screw finger-tight.
6. Insert the lower mounting pin (B, **Figure 24**) through the caliper and thread it into the slider lug. Tighten the mounting screw finger-tight.

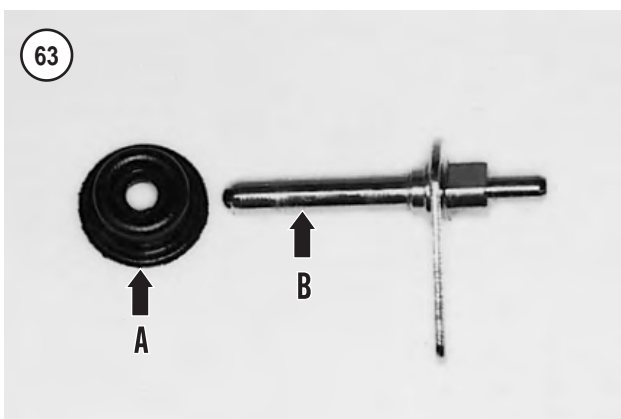
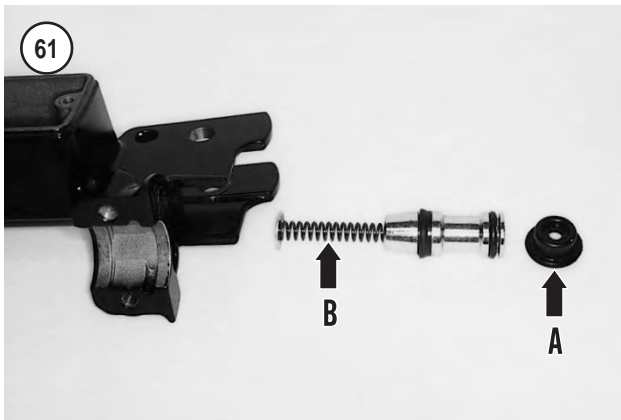
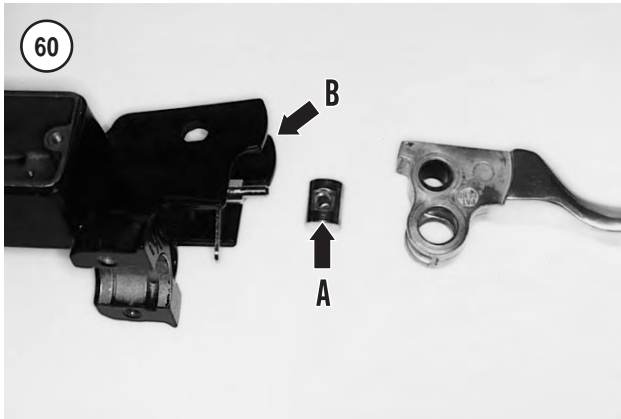

4. Position the spring with the wide end first and install the spring into the master cylinder.
5. Position the piston with the O-ring end going in last and install the piston into the master cylinder (**Figure 62**).
6. Slide the dust boot (A, **Figure 63**) onto the pushrod (B). Refer to **Figure 64**.
7. Assemble the brake lever as follows:

*NOTE*

*Do not seat the dust boot into the master cylinder at this time.*

- a. Slide the long end of the pushrod (**Figure 65**) into the piston with the dust boot facing the piston. Turn the pushrod so the arm faces the master cylinder.
- b. Apply a light coat of antiseize lubricant onto the reaction pin (A, **Figure 66**).
- c. Install the reaction pin (A, **Figure 66**) into the brake lever (B). Make sure the square pinhole (**Figure 67**) faces out.
- d. Slide the brake lever into the master cylinder and seat the end of the pushrod into the reaction pin hose (**Figure 68**). Hold the brake lever in this position. Install the pushrod arm into the cutout in the master cylinder.
- e. Slide the pivot pin through the master cylinder and brake lever pivot holes.

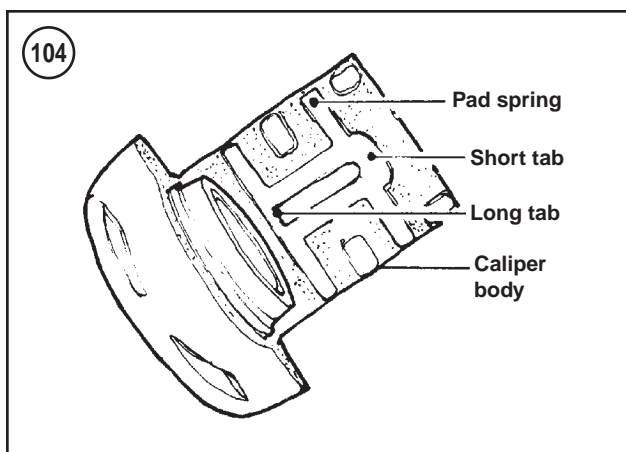
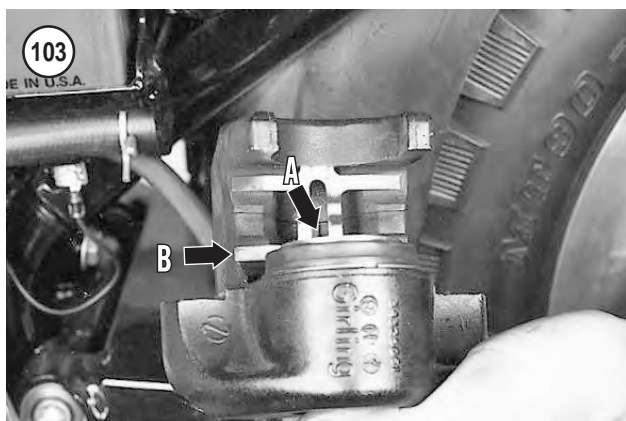

22. While the motorcycle is stationary with the engine off, apply the rear brake lever several times to seat the pads against the disc.

**WARNING**

*Do not ride the motorcycle until the brakes are operating correctly. If necessary, bleed the brake as described in this chapter.*

23. Bed the pads in gradually for the first 100 miles (160 km) by using only light pressure as much as possible. Immediate hard application glazes the new brake pads and greatly reduces their effectiveness.

## REAR BRAKE PADS (LATE 1987-1999 MODELS)

There is no recommended mileage interval for changing the brake pads. Pad wear depends on personal riding habits and the condition of the brake system. Inspect the rear brake pads for uneven wear, scoring, oil contamination or other damage. Replace the brake pads if the pad thickness is less than 0.062 in. (1.6 in.).

Always replace the rear brake pads as a set.

Do not disconnect the brake hose from the caliper for brake pad replacement. Only disconnect the brake hose if removing the caliper.

Review *Brake Service* in this chapter.

### Brake Pad/Pad Shim Identification

**WARNING**

*When replacing brake pads, do not mix late 1987-early 1991 and late 1991-1999 brake pads and pad shims. Otherwise, improper rear brake operation will occur. This may cause brake failure and loss of control. When purchasing new brake pads, provide the dealership with the frame serial number for parts verification.*

There was a design change between early 1991 and late 1991 models regarding the brake pads and pad shims (**Figure 105**). When purchasing replacement parts, note the following while referring to **Figure 106** (late 1987-early 1991 models) or **Figure 107** (late 1991-1999 models):

1A. On late 1987-early 1991 models, the pad shim thickness is 0.015 in. (0.38 mm).

1B. On late 1991-1999 models, the pad shim thickness is 0.030 in. (0.76 mm).

2A. On late 1987-early 1991 models, the pad shims have a tab in the middle of each long side.

2B. On late 1991-1999 models, the pad shims have an open loop at one end of the shim.

3A. On late 1987-early 1991 models, the brake pads measure approximately 3.44 in. (87.4 mm) as shown in **Figure 106**.

3B. On late 1991-1999 models, the brake pads measure approximately 3.39 in. (86.1 mm) as shown in **Figure 107**.

4. On late 1987-early 1991 models, the outboard brake pads have an angle-cut, half-size insulator mounted on the back of the pad. The inboard brake pad has a full-size insulator.

5. On late 1991-1999 models, the brake pads have full-size insulators mounted on the back of each pad.

### Replacement

Refer to **Figure 105**.

1. Tie the end of the brake pedal to the frame so it cannot be depressed. This prevents inadvertent application which may cause the piston to be pushed out of the caliper.

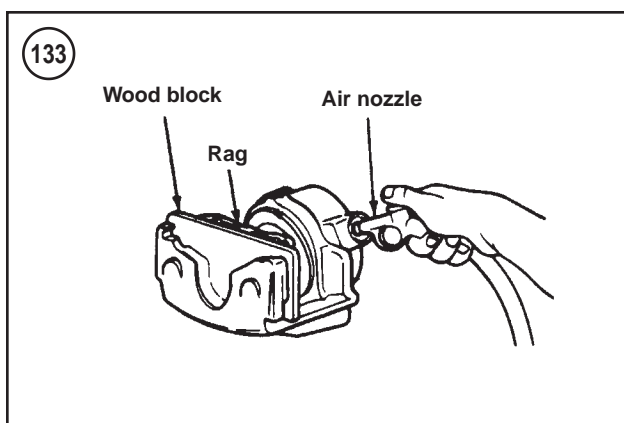
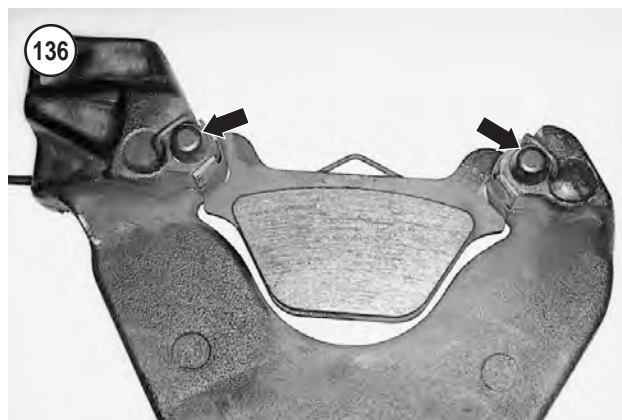

6. Remove the piston seal (A, **Figure 135**) from the groove in the caliper body and discard it.
7. Remove the rubber bushings (**Figure 136**) in the mounting bracket.

### Assembly

Refer to **Figure 129**.

1. Install the new piston seal (A, **Figure 135**) into the caliper body groove.
2. Coat the piston and the caliper bore with new DOT 5 brake fluid.
3. Position the piston (**Figure 134**) with the open end facing out and install it into the caliper bore. Then push the piston in until it bottoms.
4. Install the new piston dust boot (**Figure 132**) onto the end of the piston.
5. Locate the retaining wire groove in the end of the caliper bore and install the wire into the wire groove (**Figure 131**). Make sure the retaining wire is seated completely in the groove and that it is pushing against the piston dust boot.
6. Install new rubber bushings (**Figure 136**) into the mounting bracket if worn or damaged.
7. Install the brake pads as described in this chapter.

### Inspection

Service specifications for the rear caliper components are not available from the manufacturer. Replace worn, damaged or questionable parts.

1. Clean the caliper body and piston in new DOT 5 brake fluid or isopropyl alcohol and dry with compressed air.
2. Make sure the fluid passageways in the piston bores are clear. Apply compressed air to the opening to make sure they are clear. Flush the passageways, if necessary, with new brake fluid.
3. Make sure the fluid passageways (**Figure 137**) in the caliper body are clear. Apply compressed air to the opening to make sure it is clear. Flush the passageway, if necessary, with new brake fluid.
4. Inspect the piston ring retaining clip groove. Replace the caliper if the groove is damaged.



7. Install the spring and the spring retainer over the pushrod. Install the rubber boot, with the large end first, over the pushrod and slide over the spring retainer and spring. Then seat the spring retainer into the small end of the rubber boot. Turn the rubber boot so that the drain hole will be facing down when the master cylinder is installed on the motorcycle. Refer to **Figure 159**.

8. Slide the large flat washer over the pushrod and rest it against the rubber boot. Then push the washer down to compress the spring and install a new snap ring in the pushrod groove (**Figure 158**). Make sure the snap ring seats in the groove completely. Release the spring and allow the large washer to seat against the snap ring.

9. Install the master cylinder as described in this section.

#### WARNING

*Do not ride the motorcycle until the brakes operate properly.*

### BRAKE HOSE AND LINE REPLACEMENT

Review *Brake Service* in this chapter.

A combination of steel and flexible brake lines are used to connect the master cylinder to the brake caliper. Banjo bolts are used to connect brake hoses to the master cylinder or brake calipers. A threaded fitting connects the brake line to the rear master cylinder and rear brake caliper on 1986-early 1987 models. Steel/rubber banjo washers (**Figure 167**) are used to seal the hose fittings, except on early models which may use all-metal washers. Be sure to install new banjo bolt washers that match the old washers, otherwise, leaks may occur.

While there is no factory-recommended replacement interval for the brake hoses, it is a good idea to replace a hose when the flexible portion shows signs of swelling, cracking or other damage. Likewise, the brake hose should be replaced when the metal portion leaks or if there are dents or cracks.

#### Front Brake Hose Removal/Installation

A combination steel/flexible brake hose (**Figure 168**) is used to connect the front master cylinder to the front brake caliper.

When purchasing a new hose, compare it to the old hose to make sure that the length and angle of the steel hose portion is correct. Install new banjo bolt washers that match the old washers.

1. Drain the brake fluid from the front brake system as described in this chapter.

2. Before removing the brake line, note how the brake line is routed from the master cylinder to the caliper. In addition, note the number and position of the metal hose clamps and plastic ties used to hold the brake line in place. Install the

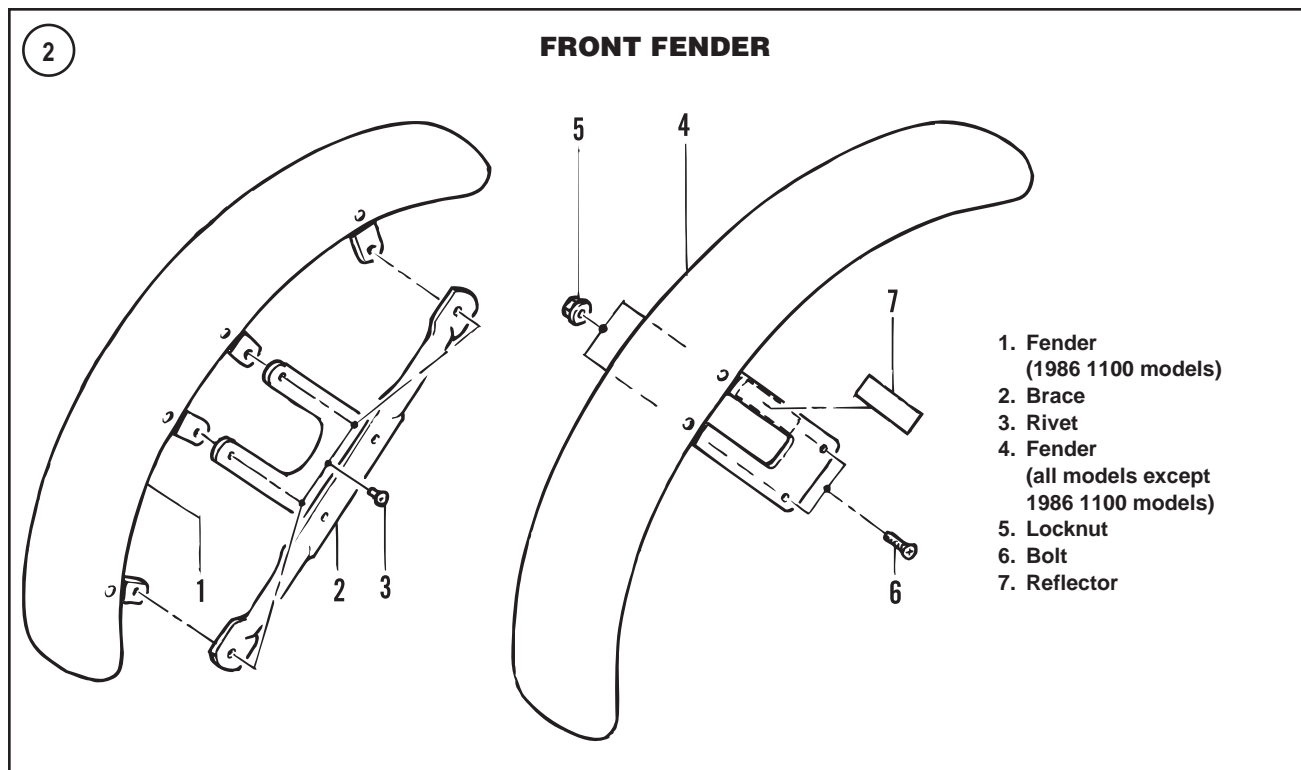

4. Reverse the removal steps to install the front fender. Tighten the locknuts to 96-156 in.-lb. (11-18 N•m).

## REAR FENDER

### Removal/Installation

#### 1986-1993 models

Refer to **Figure 3**.

1. Remove the seat as described in this chapter.
2. Disconnect the negative battery cable (Chapter Twelve).
3. Locate the turn signal and taillight/brake light terminal block in the area beneath the seat. Disconnect the terminal block connectors. Remove the connector on the wire lead to the rear fender as described in Chapter Twelve.
4. Remove the circuit breakers (A, **Figure 4**) from the retaining clips on the rear fender.
- 5A. On 1986-1989 models, remove the turn signal mounting bolts inside the fender and remove turn signals.
- 5B. On 1990-1993 models, remove the turn signal retaining nuts inside the fender and remove turn signals.
6. Note the location of spacers when removing fender retaining fasteners. Remove the mounting bolt, spacer and locknut that attaches the front of the fender to the frame bracket (B, **Figure 4**).
7. Remove bolts on both sides of the fender (**Figure 5**, typical) and remove the fender.
8. Reverse the removal steps to install the rear fender while noting the following:

- a. Install the short fender mounting bolts in the rear fender mounting holes.
- b. Install the fender mounting bolt (B, **Figure 4**) so the nut is on top. Tighten the nut to 120 in.-lb. (13.6 N•m).
- c. On 1986-1989 models, tighten the turn signal mounting bolt to 33 ft.-lb. (45 N•m).
- d. On 1990-1993 models, tighten the turn signal retaining nut to 96-156 in.-lb. (11-17 N•m).

#### 1994-2003 models

Refer to **Figure 6**, typical.

1. Remove the seat as described in this chapter.
2. Note the location of spacers when removing fender retaining fasteners. Remove the mounting bolt, spacer and locknut that attaches the front of the fender to the frame bracket (**Figure 7**).
3. On both sides, remove the rear turn signal retaining nut and spacer on the inside of the rear fender.
4. On both sides, remove the strut cover retaining screws, nuts and spacers (**Figure 5**). Move the strut covers out of the way.
5. On 1994-1998 models, locate the turn signal and taillight/brake light connectors in the area beneath the seat. Disconnect the connectors. Remove the connector on the taillight/brake light wire lead to the rear fender as described in Chapter Twelve.
6. On 1999-2003 models, depress the locking tab on the top of the connectors and remove the left- and right-turn

# INDEX

## A

- Air filter ..... 139-140
  - backplate
    - 1986-1987 models ..... 333
    - 1988-2003 models ..... 350
- Alternator
  - 1986-1990 models ..... 403-404
  - 1991-2003 models ..... 404-408

## B

- Battery
  - 1986-1996 models ..... 393-398
  - 1997-2003 models ..... 398-402
  - charging rates/times
    - approximate ..... 464
- Body
  - fender
    - front ..... 590-591
    - rear ..... 591-594
  - footrests ..... 594
  - fork lock ..... 599
  - forward foot controls,
    - 1999-2003 883C
    - and 1200C models ..... 594-598

- seat ..... 590
- sidestand ..... 598-599
- torque ..... 600
- Brake
  - adjustment ..... 131
  - bleeding the system ..... 586-588
  - caliper
    - front
      - 1986-1999 models ..... 540-544
      - 2000-2003 models ..... 545-548
    - caliper
      - rear
        - 1986-early 1987 models .. 567-569
        - late 1987-1999 models ... 569-572
        - 2000-2003 models ..... 572-575
  - disc front and rear ..... 584-586
  - fluid,
    - change ..... 131
    - draining ..... 588-589
    - level inspection ..... 129-130
    - selection ..... 533
  - flushing the brake system ..... 589
  - front brake lever pivot pin
    - lubrication ..... 123
  - hose and line replacement ... 581-584
  - inspection ..... 129-130

- light switch
  - front ..... 446-447
  - rear ..... 450
- master cylinder
  - front
    - 1986-1995 models ..... 548-552
    - 1996-2003 models ..... 552-557
  - rear
    - 1986-early 1987 models .. 575-577
    - late 1987-2003 models ... 577-581
- pads
  - front
    - 1986-1999 models ..... 535-538
    - 2000-2003 models ..... 538-540
  - inspection ..... 129
  - rear
    - 1986-early 1987 models .. 557-561
    - 2000-2003 models ..... 565-567
    - late 1987-1999 models ... 561-565
- service ..... 533-535
- specifications ..... 589
- torque ..... 589
- troubleshooting ..... 111

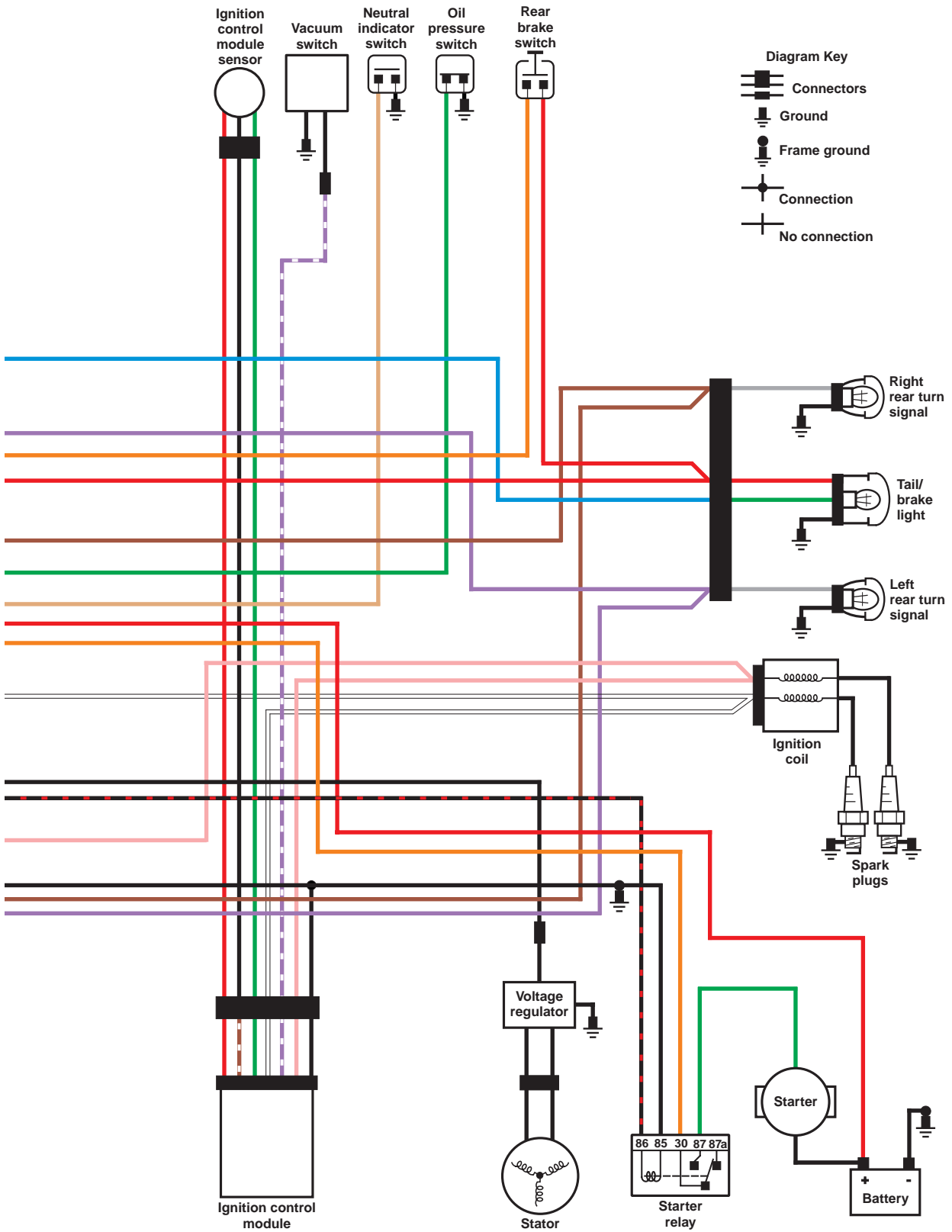

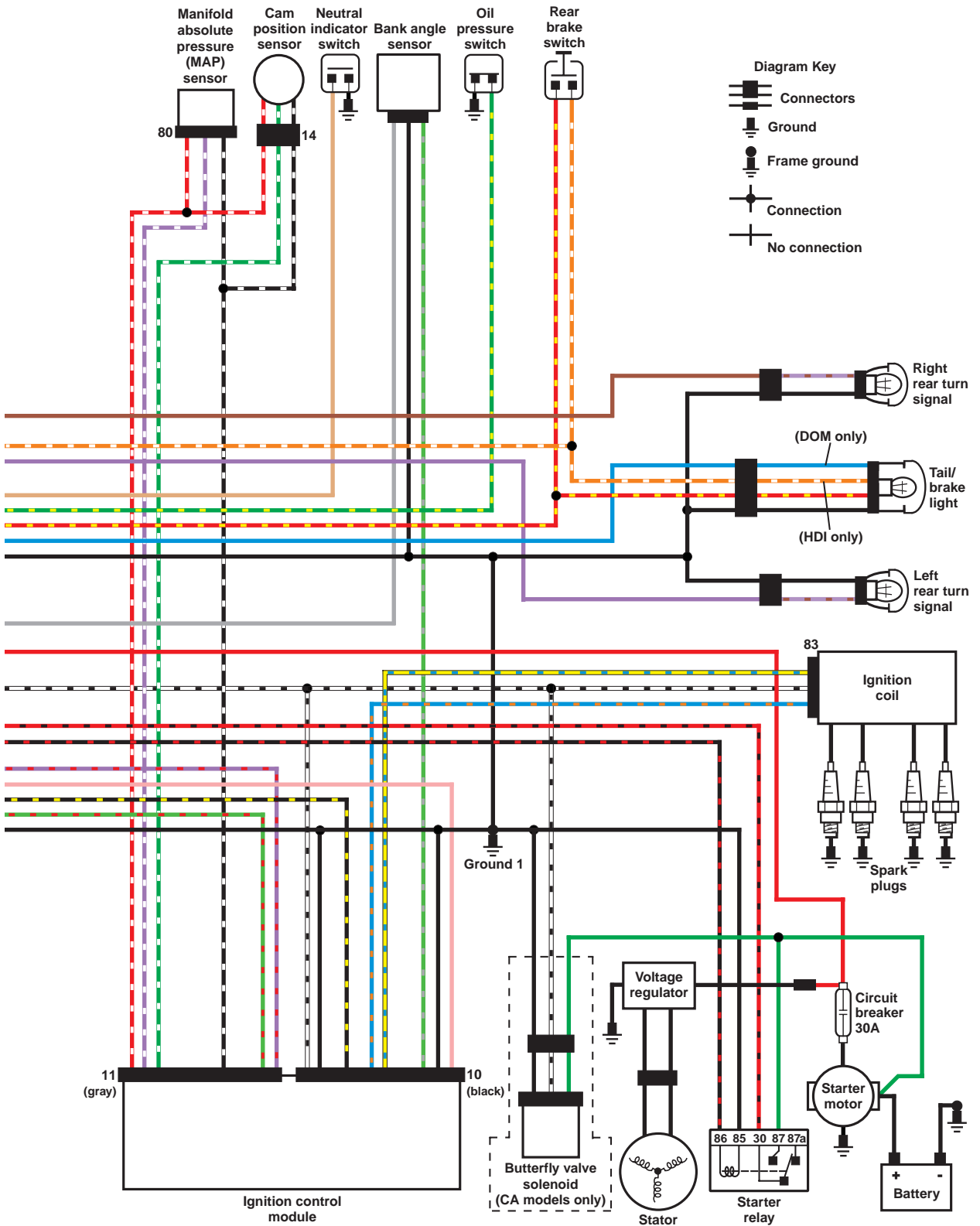

CLICK HERE TO **DOWNLOAD** THE COMPLETE MANUAL

- Thank you very much for reading the preview of the manual.
- You can download the complete manual from: [www.heydownloads.com](http://www.heydownloads.com) by clicking the link below



- Please note: If there is no response to CLICKING the link, please download this PDF first and then click on it.

CLICK HERE TO **DOWNLOAD** THE COMPLETE MANUAL