

Genie®

A TEREX COMPANY

WORKSHOP MANUAL

Code 57.4401.2200 - 2nd Edition 05/2007

Handler with telescopic boom

GTH 66-22 (From serial n. 11982)

GTH 66-22S (From serial n. 10816)

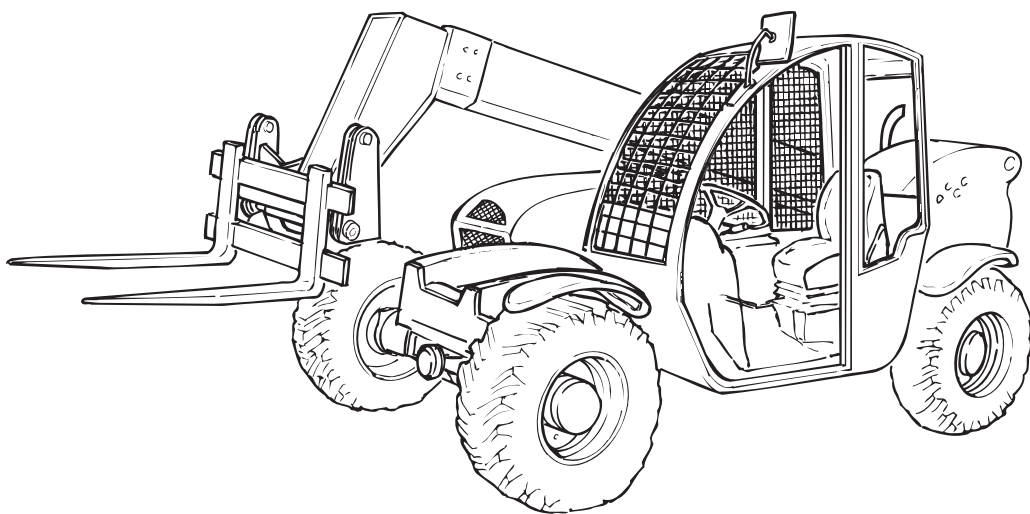

English
Edition

INDEX

CLICK HERE TO **DOWNLOAD** THE COMPLETE MANUAL

- Thank you very much for reading the preview of the manual.
- You can download the complete manual from: www.heydownloads.com by clicking the link below



- Please note: If there is no response to CLICKING the link, please download this PDF first and then click on it.

CLICK HERE TO **DOWNLOAD** THE COMPLETE MANUAL

Section 1

SAFETY INFORMATION

SECTION INDEX

1.1	Safety rules	page	2
1.1-1	Personal safety		2
1.1-2	Workplace safety		2
1.2	General remarks		4
1.3	Servicemen's requisites		4
1.3-1	Personal protective equipment		5
1.4	General safety precautions		5
1.4-1	Working areas		5
1.4-2	Precautions during work		5

2.11 VIBRATION LEVELS

GTH 66-22 • GTH 66-22S			
•	Mean assessed vibration level transmitted to arms	m/s ²	< 2.5
•	Mean assessed vibration level transmitted to body	m/s ²	< 0.5

Values calculated in accordance with standard prEN13059

CAUTION

This is a Class A device. In a residential environment, such device can cause radio disturbance. In such cases, the operator is required to take suitable measures.

2.12 REFUELLING

GTH 66-22 • GTH 66-22S			
•	Diesel engine	l	11+3,5
•	Fuel tank	l	92
•	Hydraulic oil tank	l	90
•	Front differential gear with reduction gear	l	6
•	Rear differential gear	l	5
•	Front wheel reduction gears	l	1,5 + 1,5
•	Rear wheel reduction gears	l	0.7 + 0.7
•	Brake oil tank	l	0.1

Products:

Engine oil: **SHELL RIMULA SAE 15W-40 (API CH-4/ CG-4/ CF-4/CF, ACEA E3, MB 228.3)**

Power divider-Differential gears-Reduction gears: **FUCHS TITAN GEAR LS 85 W-90 (API GL-5 LS / GL-5)**

Hydraulic system and brakes: **SHELL TELLUS T 46 (DENISON HF-1 DIN 51524 part. 2 e 3)**

Code	Description	Q.ty
07.0721.0019	Ball joint	1
07.4529.0091	Gasket kit	1
07.0705.0082	Gasket kit	1
54.0201.0008	Bushing	2
640096	Gasket kit	1
54.0201.0011	Bushing	2
639993	Gasket kit	1
04.0605.0249	Flexible hose	1
07.0703.0096	Removing battery	1
07.4501.0059	Relay	1
07.0703.0061	Fuse 70 A	2
07.0703.0060	Fuse 50 A	2
07.0703.0178	Relay	1
07.0703.0081	Fuse 2 A	5
07.0703.0080	Fuse 5 A	5
634972	Fuse 7,5 A	5
07.0703.0079	Fuse 10 A	5
634973	Fuse 15 A	5
07.0703.0179	Relay	1
07.0709.0117	Wheel stud	8
017.0709.0118	Nut	8
56.0013.0015	Proximity switch	1
07.0709.0417	Gasket kit	1
07.0723.0288	Glass	1
07.0703.0088	Switch	1
07.0723.0144	Handle lock	1
641019	Handle	1
07.0723.0188	Lock	1
07.0723.0140	Stop belt	1
07.0723.0219	Glass	1
07.0723.0221	Wiper motor	1
07.0723.0036	Wiper arm	1
07.0723.0037	Wiper blade	1

GTH 66-22 • 66-22S filters

Code	Description	Q.ty
07.0723.0149	Filter	2
07.4501.0067	Oil filter	2
07.4501.0068	Fuel filter	2
640885	Cartridge	2
07.4501.0041	Cartridge	2
09.4604.0004	Filter	2
07.0700.0000	Filter cartridge	2

HYDRAULIC SYSTEM - FORK BALANCING

annex 4

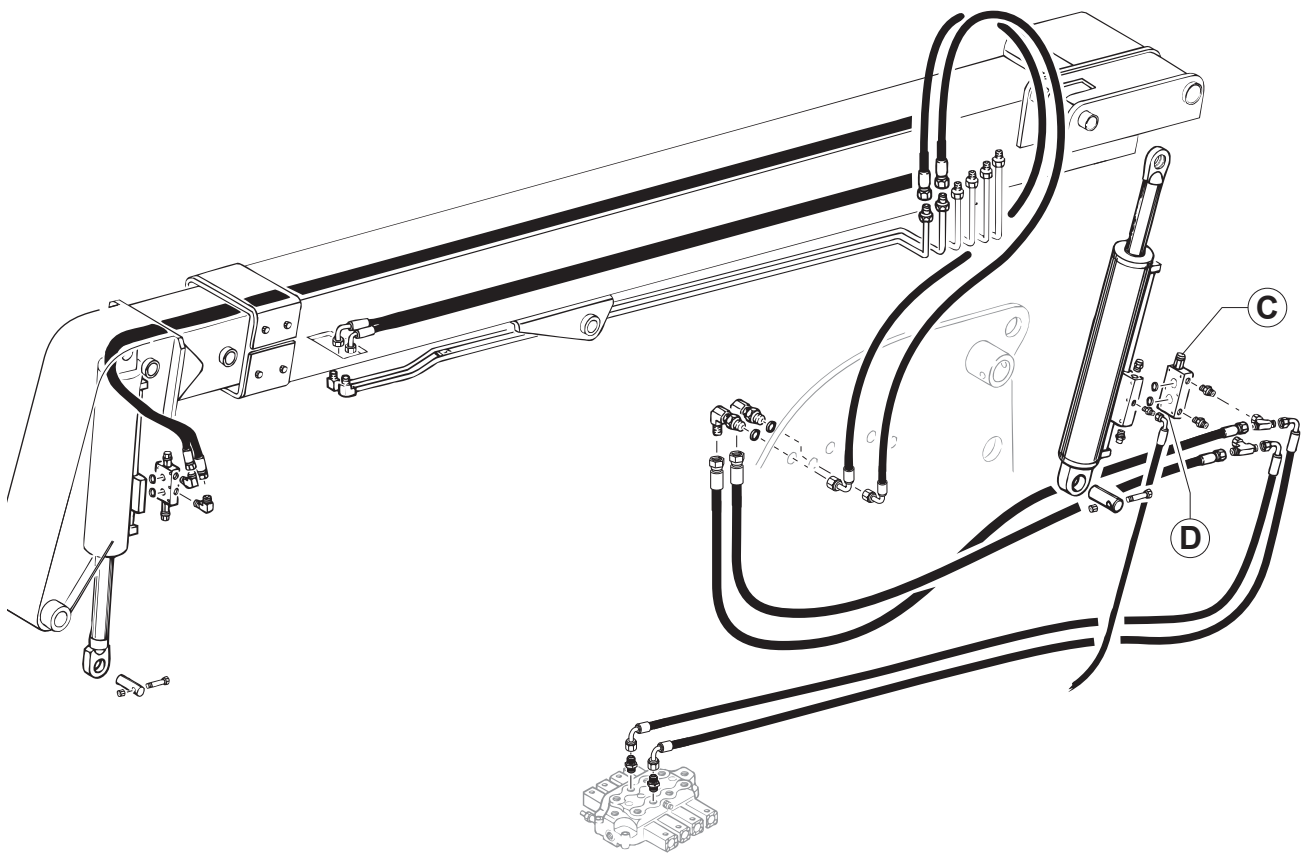

Section 4

SCHEDULED MAINTENANCE PROCEDURES

SECTION INDEX

4.1	Introduction.....	page	2
4.2	About this section		3
4.3	TABLE A procedures		4
4.4	TABLE B procedures.....		20
4.5	TABLE C procedures.....		25
4.6	TABLE D procedures.....		39
4.7	TABLE E procedures.....		46

A-10 CHECK THE HYDRAULIC OIL LEVEL IN THE TANK

⚠ DANGER

Fine jets of hydraulic oil under pressure can penetrate the skin. Do not use your fingers, but a piece of cardboard to detect oil leaks.

Check the hydraulic oil level (visually) through the special level **B** fitted into the tank.

When necessary, add new oil through filler **A**.

⚠ WARNING

Check the oil level with the machine in the travel position, that is boom lowered and telescopes fully in.

NOTICE

The handling and disposing of used oils can be ruled by local or national regulations. Address to authorised centres.

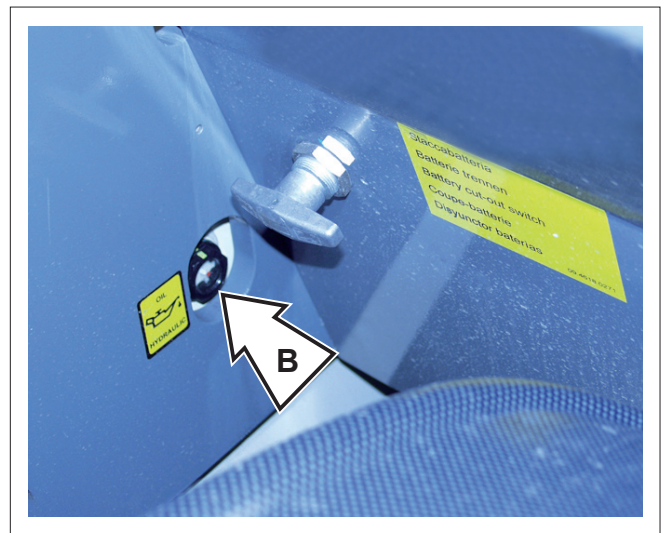
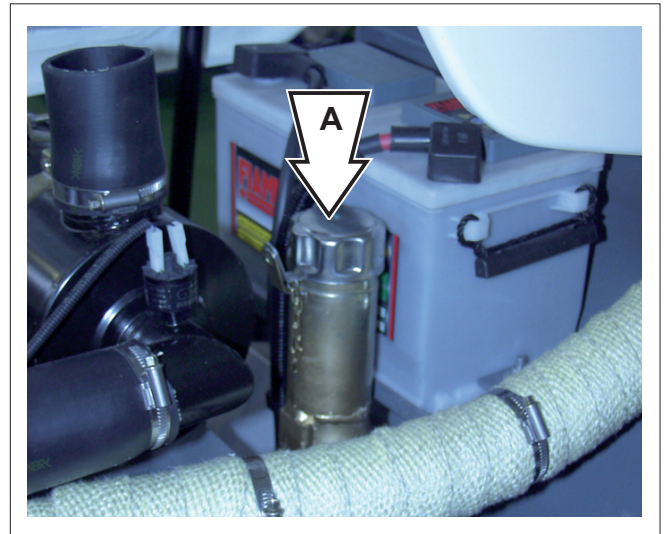

CLICK HERE TO **DOWNLOAD** THE COMPLETE MANUAL

- Thank you very much for reading the preview of the manual.
- You can download the complete manual from: www.heydownloads.com by clicking the link below



- Please note: If there is no response to CLICKING the link, please download this PDF first and then click on it.

CLICK HERE TO **DOWNLOAD** THE COMPLETE MANUAL

B-3 CHECK THE TYRE INFLATION

⚠ DANGER

Over-inflated or overheated tyres can burst. Do not flame-cut or weld the wheel rims. For any repair work, call in a qualified technician.

OKAY

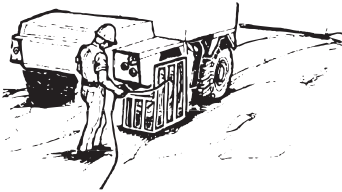

WRONG

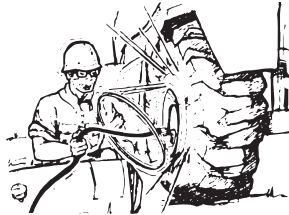

For the tyre inflation or substitution, please refer to the table below:

	STANDARD GTH 66-22 • 66-22S	OPTIONAL GTH 66-22 • 66-22S
Dimensions (front and rear)	405/70 R24	400/70 R20
P.R. (or load index)	14 pr	-
Wheel disc	8 holes DIN 70361	8 holes DIN 70361
Pressure bar/Psi	4.0/58	-

On new machines, and when a wheel has been disassembled or replaced, check the nut torque of the wheels every 2 hours until they stay correct.

⚠ WARNING

Always use tyres having the dimensions indicated in the vehicle registration card.

C-8 CHECK THE CYLINDER CHROMIUM-PLATED RODS

Visually check the cylinder rods for scoring every month.

For this operation, fully extend all of the cylinders and check that their rods are intact.



D-5 CHANGE THE HYDRAULIC OIL FILTER OF THE TRANSMISSION

Every 50 hours, check the clogging degree of the filtering element using the vacuumeter **A**.

The indexed scale of the vacuumeter is divided into 3 areas:

- 1 - Green area:** Normal condition
- 2 - Yellow area:** Replace the filter as soon as possible
- 3 - Red area:** Shut the engine down to prevent damage to the hydraulic system. Change the filter and/or check for the fault reasons.

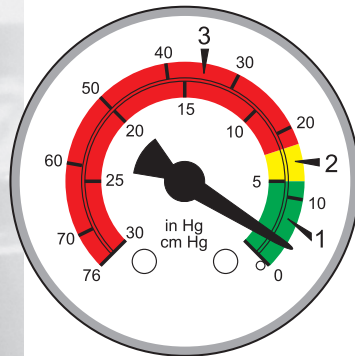
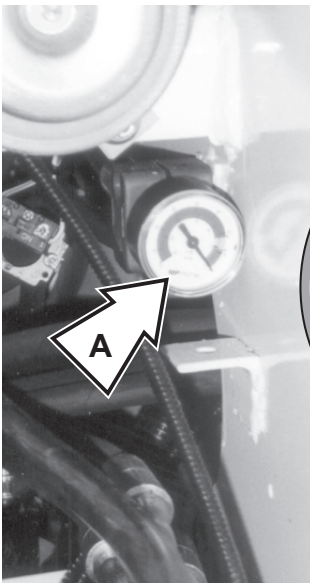

To change the hydraulic oil filter element on the suction line, proceed as follows:

- Stop the machine on a level ground and engage the parking brake.
- Place a container of suitable size under the filter to collect any oil leaks, then close cock **B**.
- Remove the filtering element **C** using a wrench.
- Change the filtering element, then, before fitting a new one, thoroughly clean and grease both seat and gasket.
- Hand-tighten and re-open cock **B**.

NOTICE

The handling and disposing of used oils may be ruled by local or national regulations. Address to authorised centres.

CAUTION

Hydraulic oil filter canisters cannot be cleaned or washed and refitted.

They must be replaced with new ones of the type recommended by the manufacturer:

Flow rate I/1' = MPS 150

Filtering = 10 μ

code = 09.4604.0001

CAUTION

When changing the oil, drain it when it is still hot and the polluting substances are in suspension.

Section 5

TROUBLESHOOTING

SECTION INDEX

5.1	Introduction.....	page	2
5.2	About this section		3
5.3	Problems-Causes-Solutions.....		4
5.3.1	Hydraulic faults.....		4
5.3.2	Electrical faults.....		9

Problem	Cause	Solution
The engine coolant thermometer does not work	Fuse F4 blown	Change the fuse
	Indicator defective	Change the part
	Temperature sensor defective	Check and replace the sensor if necessary
	Broken or damaged wiring	Reconnect or replace the wiring
High hydraulic oil temperature	Hydraulic oil bulb damaged	Check or replace the bulb if necessary
	Indicator defective	Change the part
	Radiator clogged	Check the radiator and eliminate any impurities from the fins
The joystick does not operate the boom extension/retraction	Fuse F12 blown	Change the fuse
	Road-jobsite-platform selector damaged	Check and replace the selector if necessary
	Yellow button on control lever	Check the efficiency of the yellow pushbutton
	Main valve selection valve	Check the efficiency of the solenoids and replace if they are damaged
	Broken or damaged wiring	Reconnect or replace the wiring
The joystick does not operate the attachment locking/unlocking	Fuse F12 blown	Change the fuse
	Red button on control lever	Check the efficiency of the red pushbutton
	Main valve selection valve	Check the efficiency of the electrical coils and replace if they are damaged
	Mouvement selection button	Check the efficiency or replace

6.4 WIRING DIAGRAMS

6.4.1 Up to serial no. 17055

Sheet 1 of 8

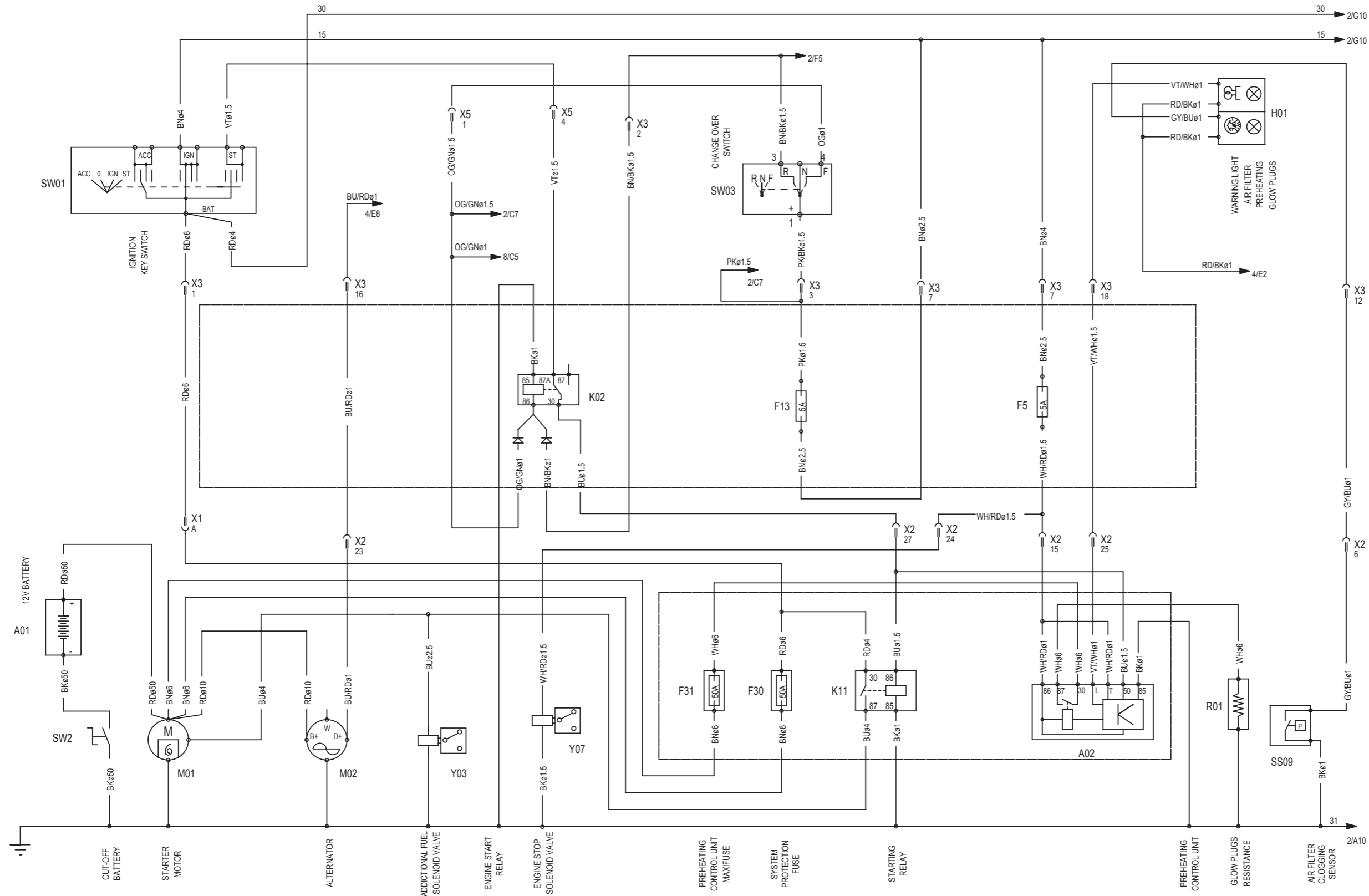

LIST OF ABBREVIATIONS

Label	Description
F##	Fuses
H##	Lamps, lights, warning lights
HA##	Clacson or back-up horn
K##	Relays
M##	Motor or pump
P##	Indicators
R##	Resistance
RP##	Potentiometers
SW##	Switches, selectors
SS##	Sensors, micro-switches, pressure switches, transducers
Y##	Solenoid valves
X##	Connectors
A##	Other components

COLOUR TABLE

Acronym	Colour
BK	Black
BN	Brown
RD	Red
OG	Orange
YE	Yellow
GN	Green
BU	Blue
VT	Purple
GY	Grey
WH	White
PK	Pink
TQ	Light blue

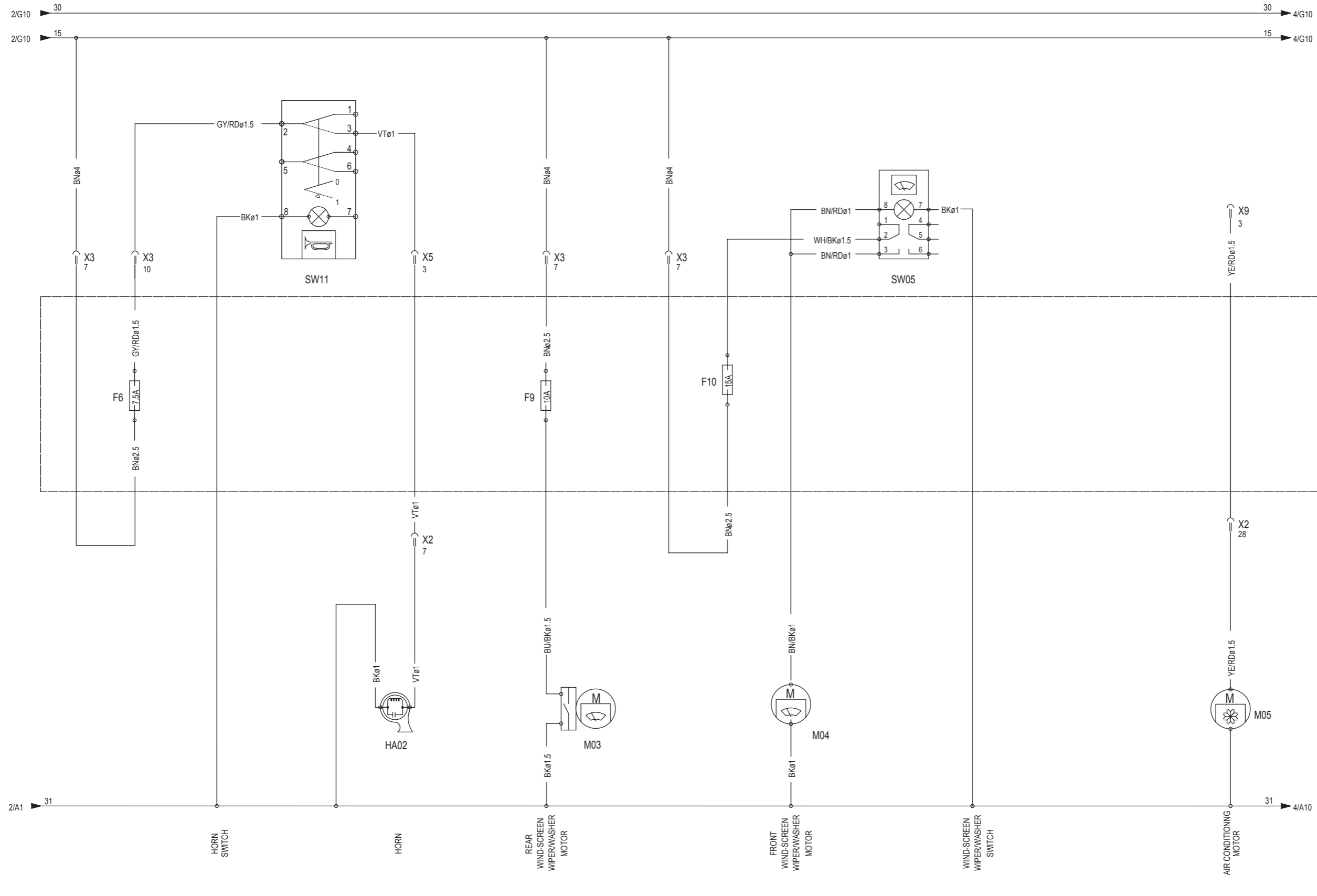

LIST OF ABBREVIATIONS

Label	Description
F##	Fuses
H##	Lamps, lights, warning lights
HA##	Clacson or back-up horn
K##	Relays
M##	Motor or pump
P##	Indicators
R##	Resistance
RP##	Potentiometers
SW##	Switches, selectors
SS##	Sensors, micro-switches, pressure switches, transducers
Y##	Solenoid valves
X##	Connectors
A##	Other components

COLOUR TABLE

Acronym	Colour
BK	Black
BN	Brown
RD	Red
OG	Orange
YE	Yellow
GN	Green
BU	Blue
VT	Purple
GY	Grey
WH	White
PK	Pink
TQ	Light blue

CLICK HERE TO **DOWNLOAD** THE COMPLETE MANUAL

- Thank you very much for reading the preview of the manual.
- You can download the complete manual from: www.heydownloads.com by clicking the link below



- Please note: If there is no response to CLICKING the link, please download this PDF first and then click on it.

CLICK HERE TO **DOWNLOAD** THE COMPLETE MANUAL