



**Gehl 650**  
**Gehl 750**  
**Gehl T750**  
**Mustang 608**  
**Mustang 708**  
**Mustang 708T**  
**Manitou MLA-6**  
**Manitou MLA-7**  
**Manitou MLA-T 516**

**Articulated Loader  
Service Manual**

**50940441 Rev. C 01/21**

CLICK HERE TO **DOWNLOAD** THE COMPLETE MANUAL

- Thank you very much for reading the preview of the manual.
- You can download the complete manual from: [www.heydownloads.com](http://www.heydownloads.com) by clicking the link below

































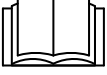



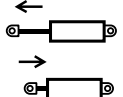















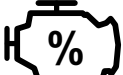

- Please note: If there is no response to CLICKING the link, please download this PDF first and then click on it.

CLICK HERE TO **DOWNLOAD** THE COMPLETE MANUAL

Load Arm Hydraulics (2 of 3).....	485
Load Arm Hydraulics (3 of 3).....	486
Tilt Cylinder Removal/Installation .....	487
Tilt Cylinder Removal .....	487
Tilt Cylinder Installation .....	491
Inner Load Arm Hydraulic Tube and Hose Removal/Installation.....	495
Load Arm Hydraulic Tube and Hose Removal .....	495
Inner Load Arm Hydraulic Tube and Hose Installation .....	501
Load Arm Slide Pad Service .....	506
Load Arm Slide Pad Inspection/Shims .....	507
Front Slide Pad Replacement.....	509
Rear Slide Pad Replacement .....	510
Hose Support Removal .....	512
Hose Support Installation .....	515
Extension Indicator Potentiometer (Domestic Telescopic Machines) .....	519
Extension Indicator Potentiometer Description.....	520
Extension Potentiometer Removal .....	520
Extension Potentiometer Installation .....	521
Extension Indicator Potentiometer Calibration (Domestic Telescopic Machines Only) .....	522
<b>HVAC System.....</b>	<b>525</b>
Air Conditioning Refrigerant Recovery .....	530
Air Conditioning System Charging.....	530
700 Series / MLA-7 / MLA-T Air Conditioning Compressor Removal.....	531
700 Series / MLA-7 / MLA-T Air Conditioning Compressor Installation.....	532
<b>600 Series / MLA-6 Engine.....</b>	<b>535</b>
600 Series / MLA-6 Engine Removal .....	535
600 Series / MLA-6 Engine Installation .....	544
<b>700 Series / MLA-7 / MLA-T Engine.....</b>	<b>553</b>
700 Series / MLA-7 / MLA-T Engine Removal .....	553
700 Series / MLA-7 / MLA-T Engine Installation .....	563
<b>Engine Cooling System .....</b>	<b>573</b>
Engine Cooling System General Information .....	573
Cooling Fan Operation .....	573
600 Series / MLA-6 Radiator Removal.....	577
600 Series / MLA-6 Radiator Installation.....	581
700 Series / MLA-7 / MLA-T Radiator Removal .....	585
700 Series / MLA-7 / MLA-T Radiator Installation .....	590
<b>Troubleshooting .....</b>	<b>595</b>
Engine Troubleshooting .....	595
Indicator Lamp Troubleshooting.....	596
Seal and Hose Troubleshooting .....	597
Hydraulic System Troubleshooting.....	598
Hydrostatic Travel Drive System Troubleshooting .....	598
Electrical Troubleshooting .....	598
Electrical Inputs/Outputs.....	599
Error Codes .....	599
MCU and Keypad CAN Error Codes .....	599
Yanmar Engine Diagnostic Trouble Codes (DTC).....	601
Deutz Engine Diagnostic Trouble Codes (DTC).....	608

# Indicator and Operation Symbols

Table 2: Indicator and Operation Symbols

 Safety Hazard	 Safety Hazard	 Hydraulic Oil Filter	 Fast Speed	 Slow Speed	 Hydraulic Oil	 Hydraglide™
 Engine Start	 Engine Stop	 Engine Run	 Wear Seat Belt	 Hydraulic Pressure Relief	 Service Hours	 Engine Oil Pressure
 Remove Key	 Crush Hazard	 Road Lights/High Beam	 Crush Hazard	 Hot Surface Hazard	 Rotating Fan — Keep Away	 Safety Lock
 Read Operator's Manual	 Parking Brake	 Windshield Wiper/Washer	 Diesel Fuel	 Fan	 Auxiliary Hydraulics Flow	 Work Lights
 Load Arm Float	 Drive System Error	 Pre-Heat	 Engine Coolant Temp	 Engine Air Filter	 Horn	 Tie-Down Point
 Critical Error	 Engine Error Code	 Elevated EGT Temp	 DPF Regen Accept	 DPF Regen Cancel/Inhibit	 DPF Service	 DPF Regen
 Engine Emissions Error Code	 Lift Point	 Windshield Wiper	 Charging Fault	 Fuel Level	 Engine Power	 Temperature
 Hydraulic Oil Temp. Warning	 Engine Oil	 Road Lights/Low Beam	 Differential Lock	 Fuel Filter	 Hitch Lock	 Hitch Unlock

Additionally, as an articulated loader is turned, the load center shifts from the center of the machine to the side. As the load center moves from the center of the support base, the potential for an overturn accident increases.

## Effect of Load Arm Lowering on Stability

Lowering the load arm (C, Fig. 3) shifts the load center forward (D). To avoid overturn accidents, make sure the load is within the rated capacity for the load arm angle. Consider all operating conditions before lowering the load arm. Refer to the following sections:

- Load capacity specifications starting on page 629.
- “Telescopic Machines Load/Level Indicators (Telescopic Machines)” on page 62.
- “Special Considerations for Telescopic Machines” on page 100.
- “Longitudinal Load Moment Indicator (LLMI) (EU Telescopic Machines Only)” on page 63.

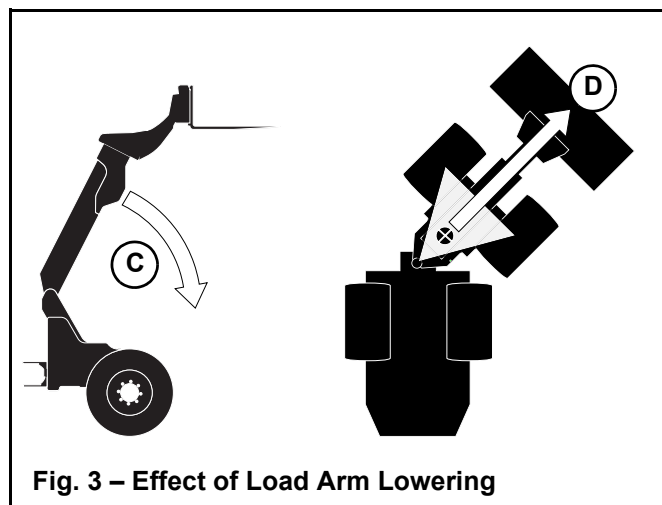

## Effect of Load Arm Extension on Stability (Telescopic Machines Only)

Extending the load arm (E, Fig. 4) moves the load center forward (F). To avoid overturn accidents, make sure that the load stays within the rated capacity for the load arm angle and extension. Consider all operating conditions before extending the load arm. Refer to the following sections:

- Load capacity specifications starting on page 629.
- “Telescopic Machines Load/Level Indicators (Telescopic Machines)” on page 62.
- “Special Considerations for Telescopic Machines” on page 100.
- “Longitudinal Load Moment Indicator (LLMI) (EU Telescopic Machines Only)” on page 63.

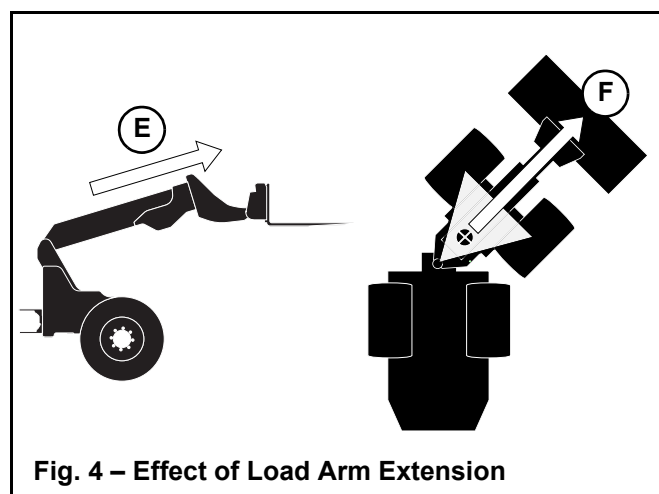

## Effect of Uneven or Unstable Ground on Stability

Articulated loaders offer increased traction on uneven surfaces (G, Fig. 5) because the tires follow the contours of the ground. However, the load center can shift (H) when the wheels are not contacting the ground along the same plane, which reduces stability.

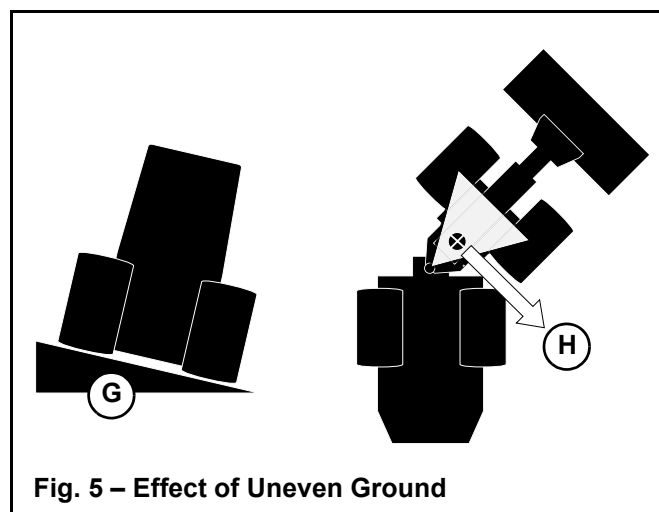

## ANSI-Style and Common Safety Decal Locations

**A**

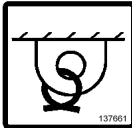

(Located at the tie-down points on the machine)

Tie-down point, located on both sides of the front and rear chassis. Only use tie-down points indicated on loader when transporting loader.

**B**

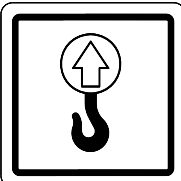

(Located near the top of the front frame and near the bottom rear of the rear frame, at the life points on the machine)

Lift Point Decal

Apply lift hooks only in these location. See "Raising the Machine using a Crane" on page 137.

**C**

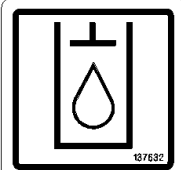

(Located in the engine compartment on the hydraulic oil filler cap)

**USE HYDRAULIC OIL ONLY!**

**D**



(Located on the right side of the machine near the fuel filler neck)

**USE DIESEL FUEL ONLY!**

**E**

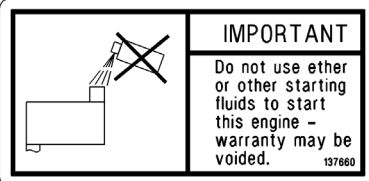

(Located on the engine air filter housing inside the engine compartment)

Caution Decal

**IMPORTANT**

**F**



(Located inside the ROPS/FOPS behind the operator's seat)

Warning Decal

**WARNING: Do not modify ROPS; replace damaged ROPS; wear seat belt**

The protection offered by this ROPS will be impaired if it has been subjected to any modification, structural damage, or has been involved in an overturn incident, this ROPS must be replaced after a rollover. Seat belts must be worn while operating vehicle.

**G**

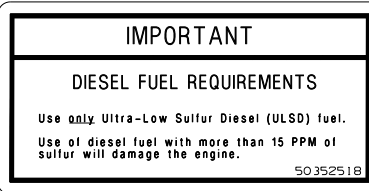

(Located on the right side of the machine near the fuel filler neck)

Caution Decal

**IMPORTANT**

- Use **ONLY** Ultra-Low Sulfur Diesel (ULSD) fuel.
- Use of diesel fuel with more than 15 PPM of sulfur will damage the engine. See "Fuel System Maintenance" on page 169.

# Indicators and Controls

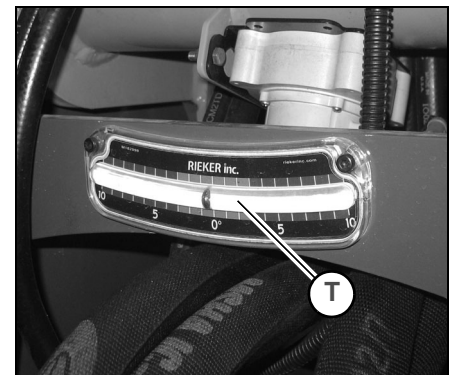
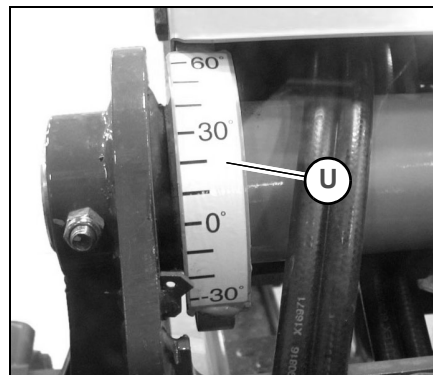
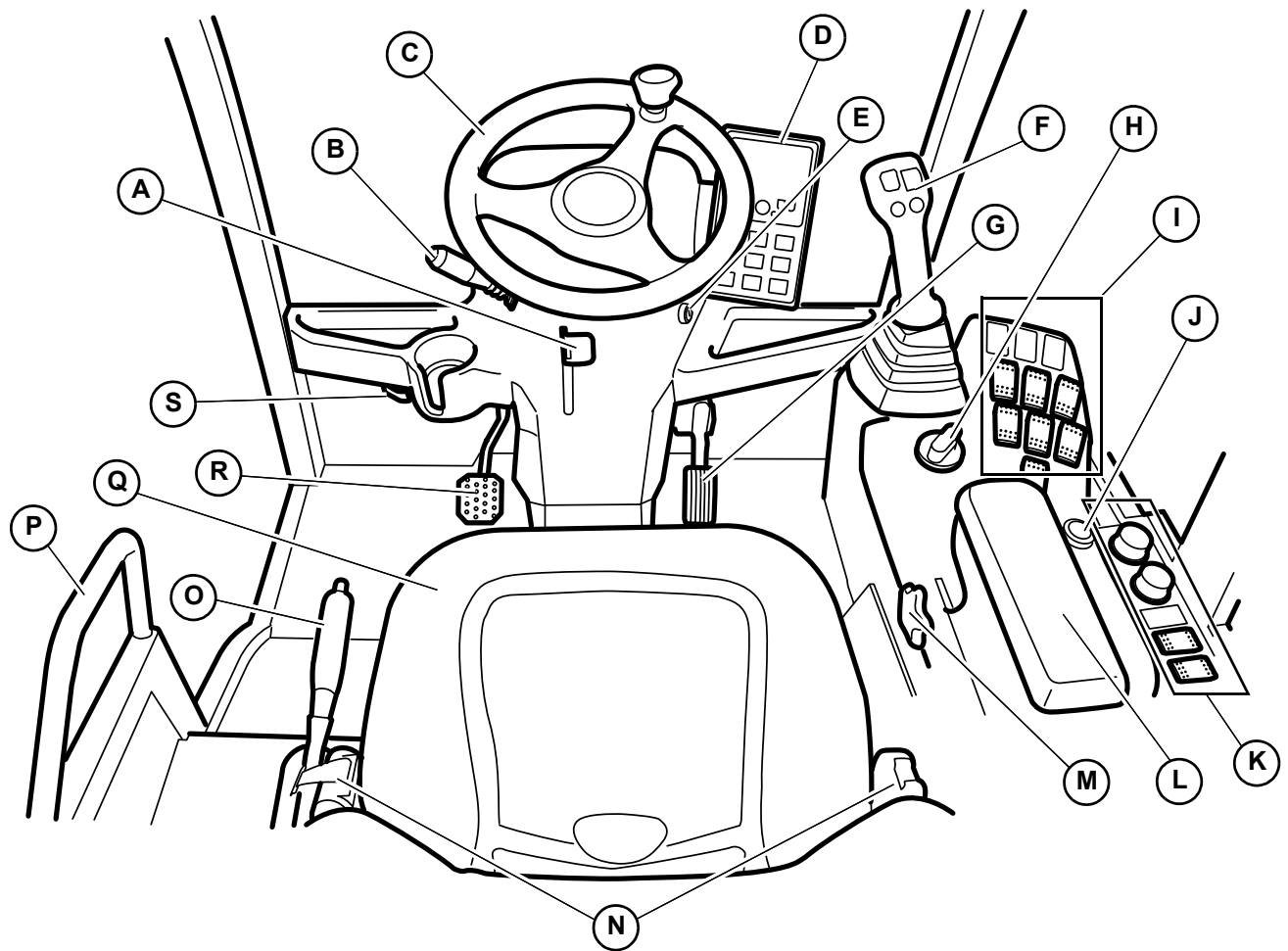
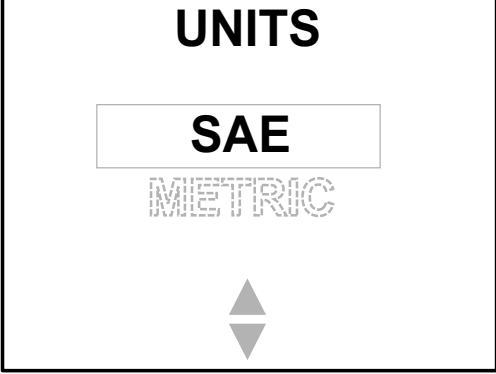
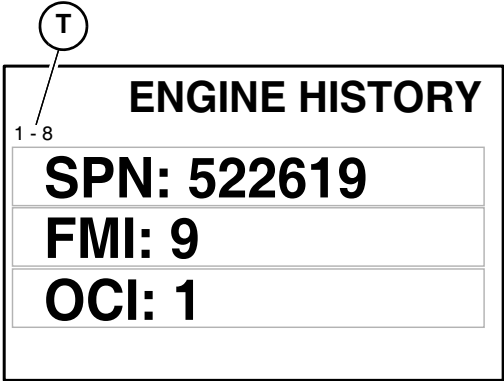
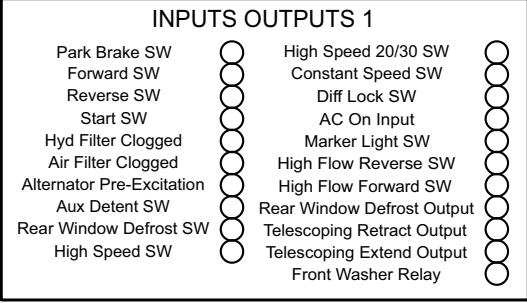

Fig. 10 – Controls

Table 3: Operator Controls

Ref	Item	Description
A	Steering Column Adjustment	Adjusts steering column tilt and height (page 72).
B	Control Lever (Option)	Controls road lights, directional indicators and horn (page 70).
C	Steering Wheel	Controls travel direction.
D	Multi-Function Display/Control Keypad	Displays operational status, error fault codes and input/output diagnostic data (page 51). Controls HVAC, lights, windshield washers/wipers, hydraulic lockout, attachment hitch lock/unlock (page 60) and cooling fan reverse (page 77).

**Table 6: Status and Maintenance Screens**

Display Mode	Description
	<p align="center"><b>Units Screen</b></p> <p>Press the top/bottom of navigation rocker button (A, Fig. 11) to switch between SAE or metric units for values displayed in the screens.</p>
	<p align="center"><b>Error/Status/History Screens</b></p> <p>Displays engine, drive system, and control system error status and history code message information. The number of available messages is displayed at the top left of the screen (T). Press the left/right side of navigation rocker button (A, Fig. 11) to switch between screens and press the top/bottom of navigation rocker button to scroll through the codes. See “Error Codes” on page 599 for specific error code details.</p>
	<p align="center"><b>Input/Output Status</b></p> <p>Displays input/output electronic/CAN status. Press the left/right side of navigation rocker button (A, Fig. 11) to switch between input/output screens. Status colors indicate the following:</p> <ul style="list-style-type: none"> <li>• Green – Active</li> <li>• Blank – Inactive</li> <li>• Yellow – Short or open circuit</li> </ul>

## Auxiliary Hydraulics Control Switch

Auxiliary hydraulics control switch (E, Fig. 27) controls auxiliary hydraulics flow. Refer to “Auxiliary Hydraulic Control” on page 76 for more information.

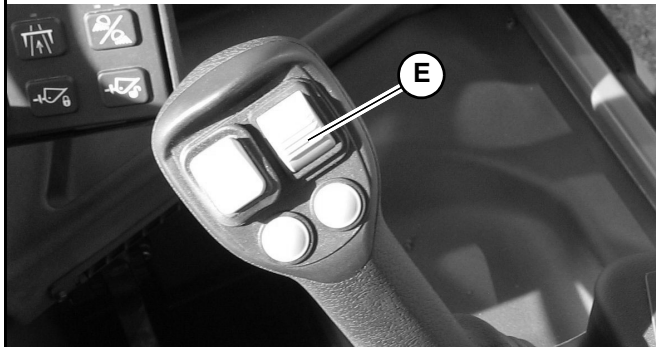
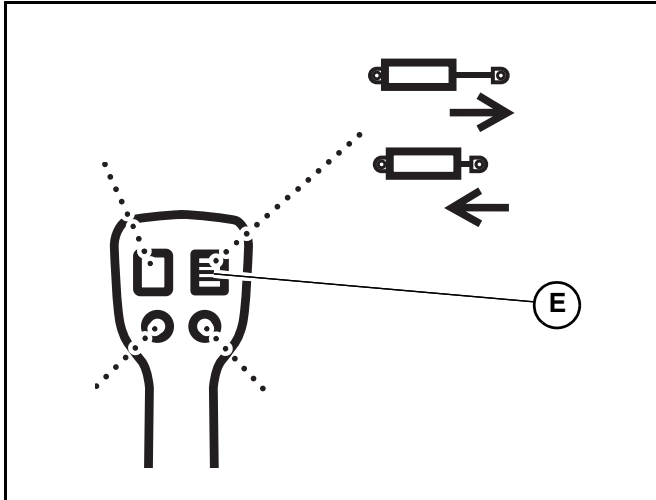

Fig. 27 – Auxiliary Hydraulics Control Switch

## Parking Brake

To engage the parking brake, raise parking brake lever (H, Fig. 28) up.

To disengage the parking brake, raise lever (H) slightly, press button (K) and lower lever (H).

**NOTE:** When the parking brake is engaged, the travel drive is disconnected.

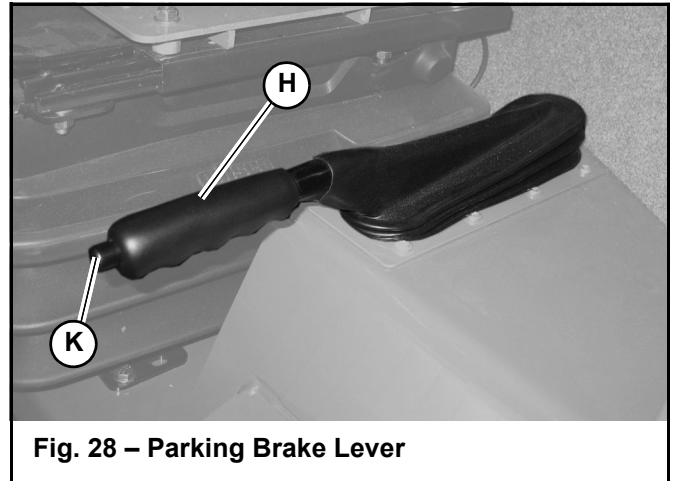

Fig. 28 – Parking Brake Lever

**IMPORTANT:** If the optional backup alarm is installed and the parking brake is released, the backup alarm activates when the travel direction switch is in reverse.

## Parking Brake Adjustment/Service

Test the parking brake each time before using the machine. Adjustment and/or service is required if the parking brake does not keep the machine from moving when parking brake lever (H) is pulled up as far as possible. Refer to “Parking Brake Adjustment/Service” on page 180.

## Load Arm Lights Button (Telescopic Machines Only)

Switch (X, Fig. 50), located on the switch panel, controls the load arm lights (T, Fig. 51).

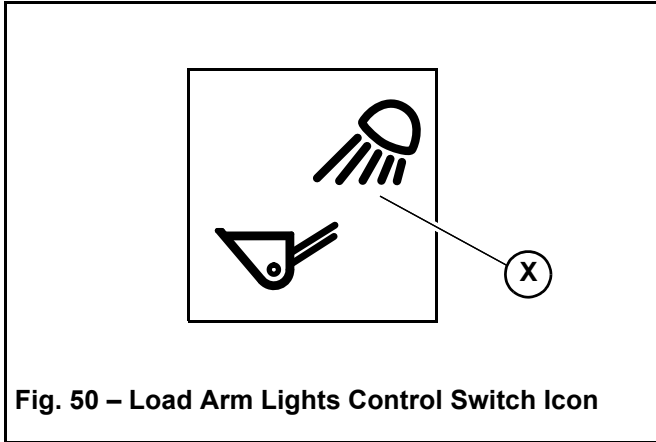

### **WARNING**

Switch off the load arm lights when traveling on public roads. The lights can dazzle motorists and cause accidents.

Press the top of switch (X, Fig. 50) to activate the load arm lights. Press the bottom of switch (X) to turn the load arm lights off.

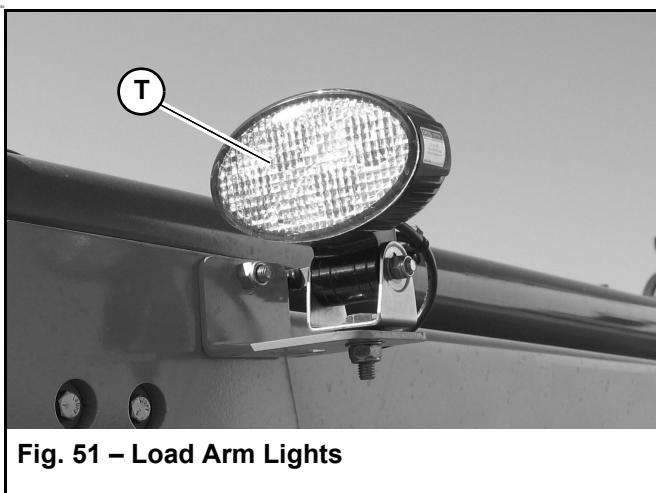

**NOTE:** The indicator on load arm lights switch (X) is lit when the load arm lights are ON.

## Beacon (Option)

On/off switch (T, Fig. 52) for optional beacon (S) is located on the right switch panel.

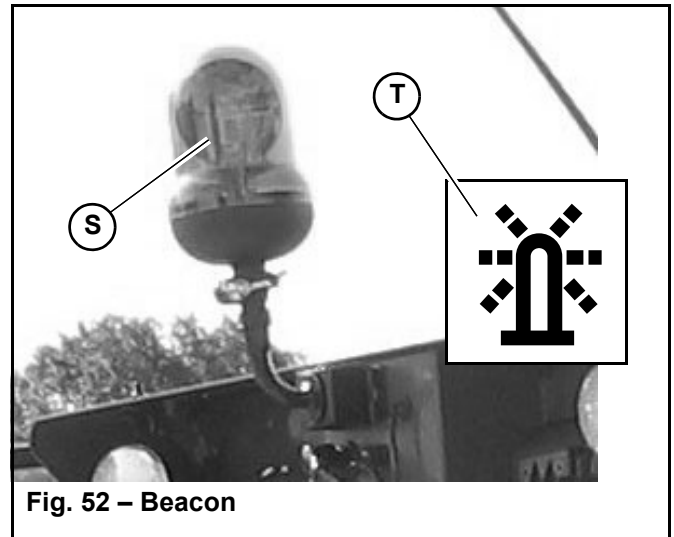

## Seat Belt

### **WARNING**

**ALWAYS** fasten the seat belt securely and properly. Never operate the machine without the seat belt fastened around the operator.

Keep the seat belt clean; dirt can impair seat belt operation. Check seat belt condition regularly and have damaged or worn belts immediately repaired by an authorized dealer.

**After an accident, the seat belt strap is stretched and must be replaced with a new strap installed by an authorized dealer.**

### ***Fastening/Unfastening the Seat Belt***

Remove hard, edged, or fragile objects from your pockets or clothes that might lie between the seat belt and your body.

Fasten the seat belt around your hips and waist and insert tongue (A, Fig. 72) into clasp (B) until it clicks securely in place. Slack in the seat belt should automatically retract into seat belt spool (K).

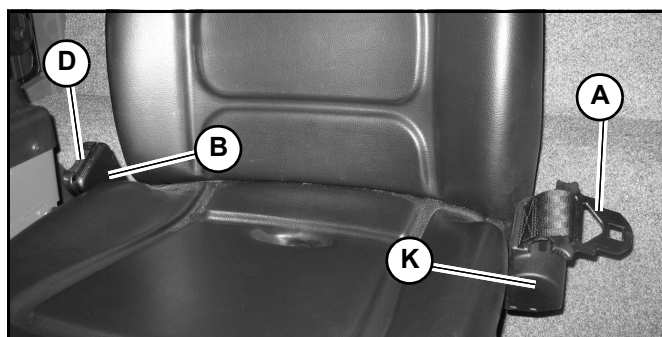

**Fig. 72 – Seat Belt**

Make sure the seat belt is not twisted when it is fastened and that it is fastened over the hips and not the stomach.

### **WARNING**

**If the seat belt spool does not retract slack in the seat belt, have it serviced immediately. Do not operate the machine until the seat belt is repaired.**

Unfasten the seat belt by pressing button (D).

## Dome Light

The dome light (Fig. 73) is located on the right side of the ROPS/FOPS headliner.

If dome light switch (W) is in the right (Z) (auto) position, the light activates by either sitting in the operator's seat or pressing a button on the keypad.

The light will deactivate:

- After approximately 10 seconds.
- If the ignition is turned on.
- If switch (W) is moved to the center (V) (OFF) position.

**NOTE:** With dome light switch (W) in the right (Z) (auto) position, the light will activate even with the ignition off.

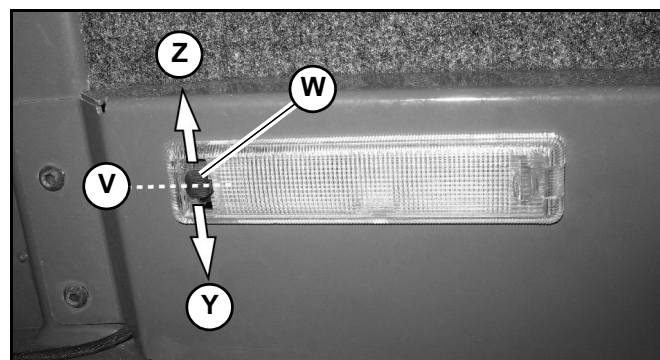

**Fig. 73 – Dome Light**

When the ignition is on, the dome light is continuously activated by moving switch (W) to the left (Y) (ON) position.

## **Travel Drive Error Condition Operation (Limited and Safe Modes)**

For safety reasons, drive system error conditions will de-rate or disable the drive system.

Certain types of errors will cause restricted modes. See “Pump and Drive Motor Error Codes” on page 223.

- In less severe (LIMITED-Mode) error cases, the travel drive operates, but pump power is reduced by 50% and the drive motor operates in full displacement, causing the machine to move slowly.

When a LIMITED-Mode error occurs, the travel direction switch on the joystick must be switched to “Neutral” (N) and then moved into either “Forward” (F) or “Reverse” (R) before the travel drive will operate.

- In severe (SAFE-Mode) error cases, the travel drive is disabled. The error can only be cleared by turning the power off.

If several errors occur at once, the errors are prioritized. The error with the lowest numeric Error Flash Code will display.

## **Backup Alarm (Option)**

If the optional backup alarm is installed and the parking brake is released, the backup alarm activates when the travel direction switch is in reverse.

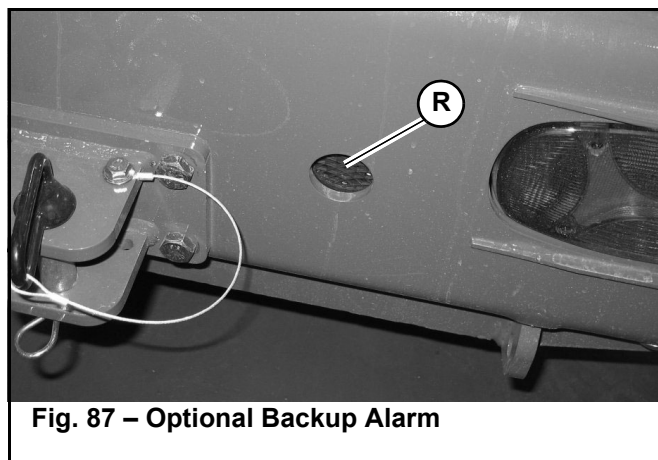

**Fig. 87 – Optional Backup Alarm**

**IMPORTANT:** *State and local regulations may have specific requirements for backup alarms. Make sure the machine is equipped as required to be in compliance with applicable regulations.*



**DANGER**

**Do not rely exclusively on the backup alarm to alert others. Make sure that nobody is within the work area when traveling in reverse.**

- Carefully position the load arm support (Z, Fig. 97) over the exposed lift cylinder rod on the left lift cylinder as shown.

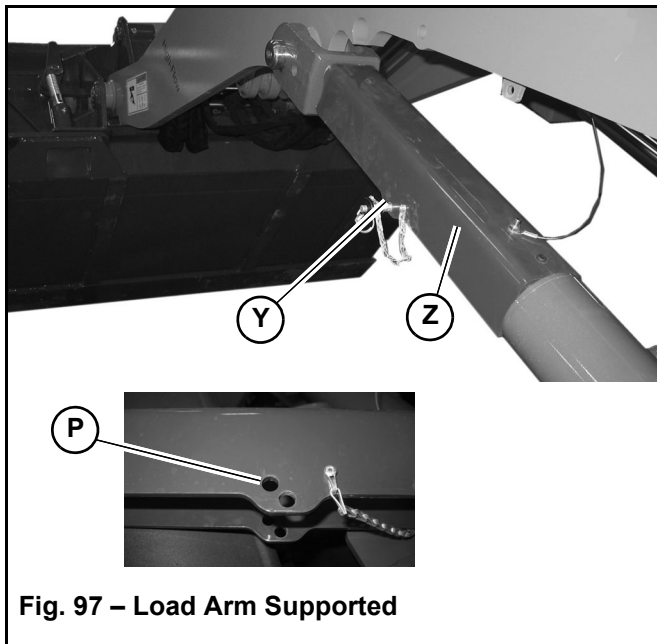

**Fig. 97 – Load Arm Supported**

- Retain support (Z) on load arm cylinder rod using retaining pin (Y) through top hole (P).
- Start the machine and lower the load arm so load arm support (Z) rests firmly against cylinder tube head and rod end. Verify that load arm support (Z) is properly positioned as shown in Fig. 95.

## **! WARNING**

**The load arm support device must be properly positioned to prevent the load arm from falling, which could result in severe injury or death.**

- Shut off the engine.
- Move the joystick in all directions to verify that the load arm and hitch plate do not move.
- Unfasten the seat belt, remove the start key and take it with you. Exit the machine using the hand-holds.

## **Disengage Load Arm Support**

### **! WARNING**

**A second person on the outside of the machine is required to assist with disengaging the load arm support.**

- Start the engine and raise the load arm until load arm support (Z, Fig. 98) can be removed from the cylinder rod on the left lift cylinder.

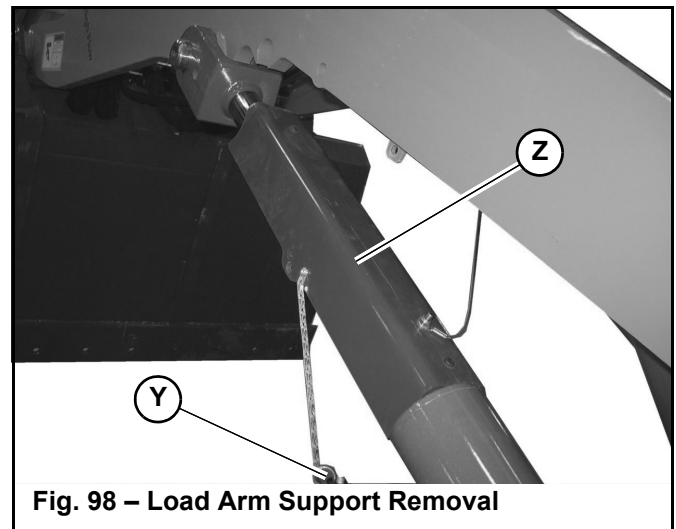

**Fig. 98 – Load Arm Support Removal**

- Move the travel direction switch on the joystick to the neutral position and engage the parking brake.
- Shut off the engine.
- Move the joystick in all directions to verify that the load arm and hitch plate do not move.

## Disconnecting Attachments Using Euro-Style and 4-Point Hitches

### **WARNING**

Position the attachment so it will stand and not tip over after disconnection. Serious injury can occur if an attachment tips over onto a person.

1. Empty the attachment.
2. On telescopic machines, fully retract the load arm.
3. Drive to an open, level area to disconnect the attachment.
4. Lower the attachment to the ground.
5. With the engine running, press hitch and hold unlock button (H, Fig. 118) until locking pins (Z, Fig. 119) are fully retracted out of the holes in the attachment.

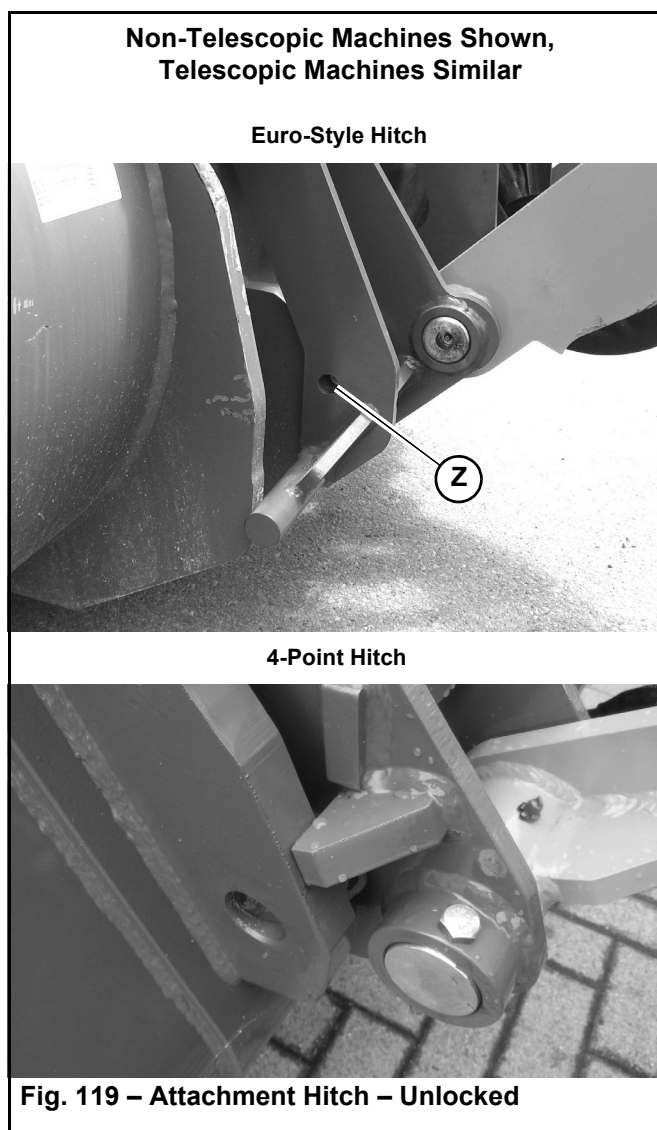
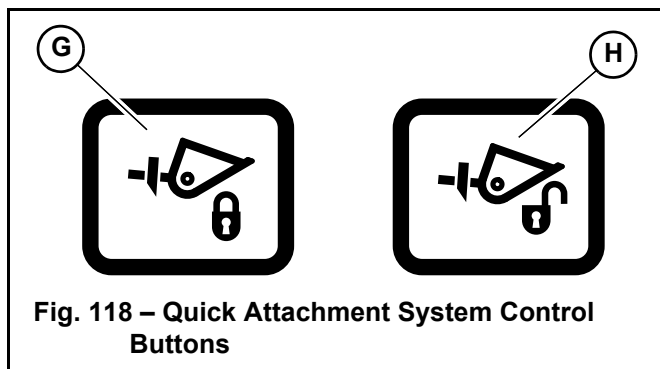

## **WARNING**

Do not use high travel speed range when using pallet forks.

**DO NOT** use standard fork arms as reverse (inverted) forks.

Never allow a load to get closer than 6 m (20 ft.) to overhead electrical lines.

**DO NOT** push, pull, or shove the fork arms or move them in at a slanting angle; the resulting lateral forces can damage the fork arms.

**DO NOT** pull loads off the fork arms, or allow loads to fall onto the forks arms.

**DO NOT** tilt the pallet forks to raise loads.

**DO NOT** raise or move molten material with pallet forks.

Repair work on fork arms must be performed only by authorized personnel.

Always keep pallet fork arms clean.

Secure loads as directed in the Operator's Manual supplied with the pallet fork to prevent the loads from falling.

Never modify pallet fork arms.

Do not raise or transport people on the pallet forks.

Do not drive on public roads with pallet forks installed on the machine.

Do not stack loads which are not properly packaged or have damaged pallets/stacking containers. Do not stack loads on top of loads, which may have shifted.

Always tilt pallet forks back slightly during travel to help retain the load.

---

## **WARNING**

Do not use bent, cracked, or otherwise damaged fork arms/pallet forks.

Always inspect pallet forks each time before using. Refer to the pallet fork manufacturer's documentation and/or contact the pallet fork manufacturer for information regarding safe pallet fork condition criteria:

- Check the fork arm locks for proper function and/or damage. Do not use pallet forks with damaged locks or locks that do not function properly.
  - Visually check the fork arm hooks and/or bends for cracks and/or deformations. Do not use fork arms that are cracked and/or have deformations that make the fork arms unsafe.
  - Do not use fork arms that have bends or blades that have more than 10 percent of the original material worn away.
  - Check the fork arms blades and tips for deformations or holes.
-

8. Provide blocking between the lifting gear and the machine at points (X, Fig. 139) as necessary on both sides of the machine to prevent damage to installed components and the engine cover.
9. Insert a spreader bar between the two legs of the lifting gear at point (V), just above the cab, to prevent damage to the cab or installed components.
10. Carefully raise the machine, keeping it as level as possible.

## Towing

### Precautions



**Tow the machine with another vehicle ONLY. Do not tow loads or other vehicles with the machine.**

**IMPORTANT:** *The machine cannot be tow-started because there is no direct mechanical connection between the wheels and the engine. Attempting to tow-start the machine may damage the drive system.*

Only tow the machine if the steering and brakes are functional, if the machine cannot be repaired on-site, and if the machine cannot be moved using any other method. Only tow the machine until it is moved to a location where it can be safely repaired.

**IMPORTANT:** *If moving the machine more than a few hundred meters, use a flatbed truck or similar vehicle to transport the machine to prevent hydraulic system overheating. See "Loading and Transporting the Machine on a Transport Vehicle" on page 141.*

### Preparation

1. Perform the "Mandatory Safety Shutdown Procedure" on page 22. Position the load arm as low as possible to allow for towing. On telescopic machines, fully retract the load arm.

2. Remove hardware (H, Fig. 141) under the machine securing access panels (I). Remove the panels.

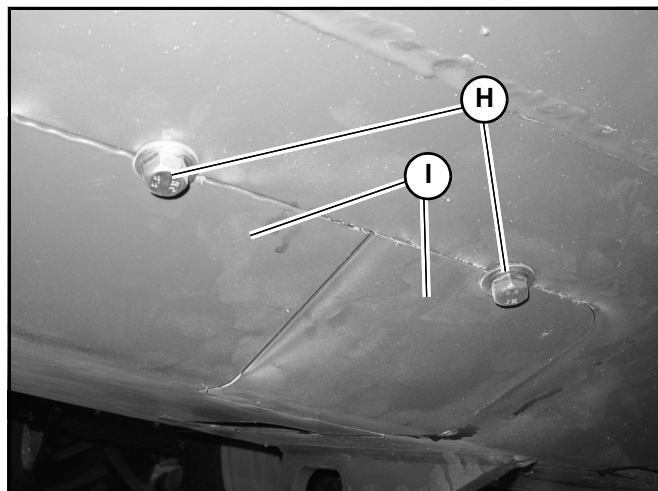

**Fig. 141 – Hydraulic Pump Access**

3. Loosen hydraulic system bypass screws (Z, Fig. 142) on the bottom of the pump three turns.



**Fig. 142 – Hydraulic System Bypass Screws**

## Lubrication and Filter Changes

**Table 16: Lubrication and Filter Changes**

Service Procedure	Maximum Interval				
	10 Hours (or daily)	50 Hours (or weekly)	150 Hours (or every 4 months)	250 Hours (or every 6 months)	1000 Hours (or annually)
Lubricate articulation joint (See Fig. 169 and Fig. 170 on page 156)	X				
Lubricate grease fittings according to lubrication diagram (See Fig. 150 on page 151)	X				
Telescopic load arm lubrication (See page 157)		X			
600 Series/MLA-6: Change engine oil and filter					X
700 Series/MLA-7/MLA-T 516: Change engine oil and filter				X <sup>1</sup>	X <sup>1</sup>
Change cab air filter, if applicable				X <sup>2</sup>	
Lubricate all levers, cables, and hinges				X	
Change outer air cleaner filter element; check and change inner air cleaner element if necessary				X <sup>2</sup>	
Change fuel filter; clean pre-filter					X <sup>3</sup>
Change coolant					X
Change axle oil					X <sup>4</sup>
Change hydraulic oil and filter					X <sup>5</sup>

1. 500 hour oil change intervals MUST meet Deutz Certification DQC III-18LA or DQA IV18 LA. All other classifications MUST follow 250 hour oil change intervals.
2. Replace if needed.
3. 608 / MLA-6: every 500 hours; 708 / 708T / MLA-7 / MLA-T 516 every 1000 hours; 500 hours under extreme conditions.
4. Every 1500 hours
5. Every 1000 hours; 500 hours under extreme conditions.

## Functional Check

**Table 17: Functional Check**

Service Procedure	Maximum Interval		
	10 Hours (or daily)	250 Hours (or every 6 months)	500 Hours (or annually)
Check seat belt	X		
Check service and parking brake function	X		
Check joystick operation	X		
Check windshield wiper function, if applicable	X		
Check control switches/buttons, indicators, and audible warning devices	X		
Check installed lighting systems	X		

5. Make sure the load arm is fully retracted and raise the load arm (H, Fig. 178) as far as it will go.

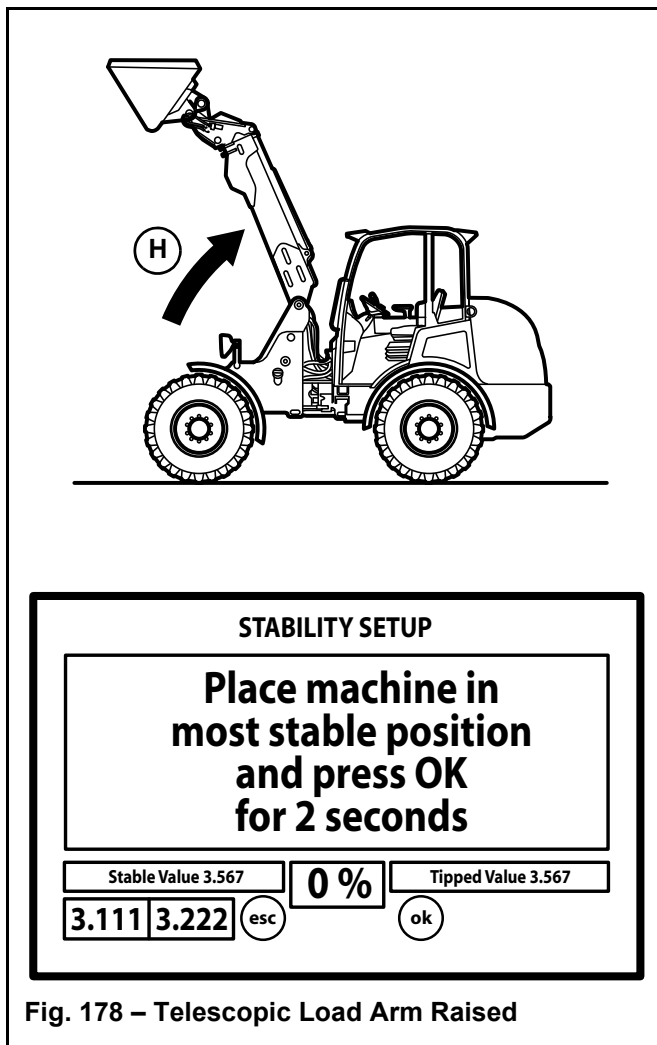

6. Press the ok button (G, Fig. 176) on the multi-purpose display for 2 seconds.
7. Release the parking brake and drive the machine to a suitable, solid, substantial object such as a dirt pile (I, Fig. 179). Position the load arm/attachment under/into the object (I) so the rear wheels of the machine can be raised off the ground using the load arm.
8. Apply the parking brake.
9. Slowly pull the joystick straight back to use the load arm to raise the machine (J) until both rear wheels are off the ground (K).

**NOTE:** Only raise the rear of the machine high enough so both rear wheels just clear the ground.

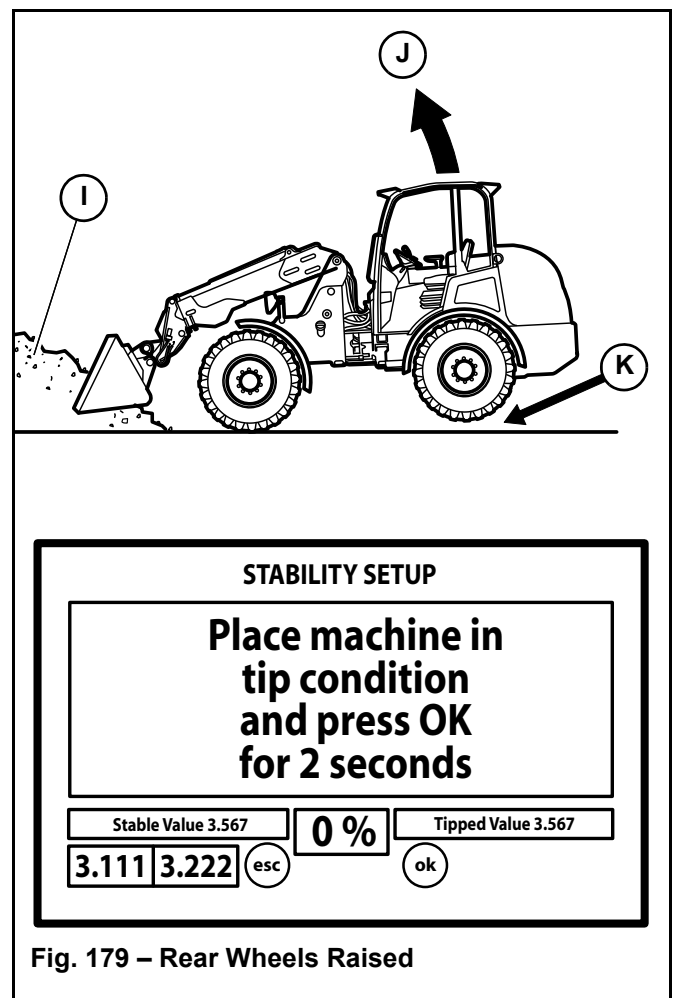

10. Press the ok button (G, Fig. 176) on the multi-purpose display for 2 seconds.
11. Press the esc button (F, Fig. 176) on the multi-purpose display.

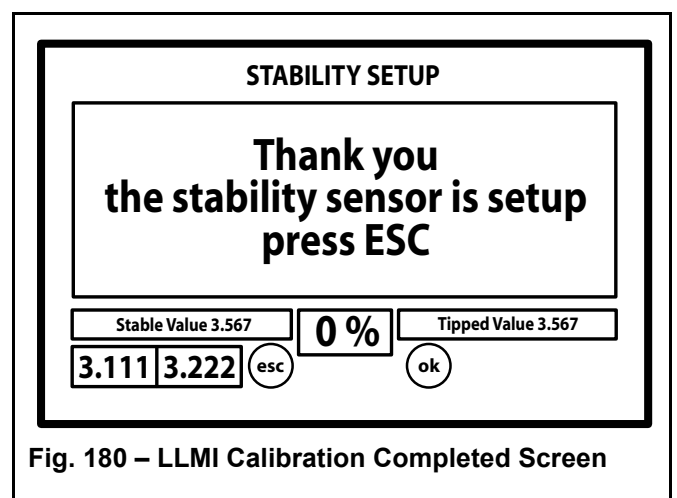

## DPF Service

### Yanmar Engines

DPF soot filter replacement is required when the DPF Service screen (Fig. 201) is shown on the multi-purpose display.

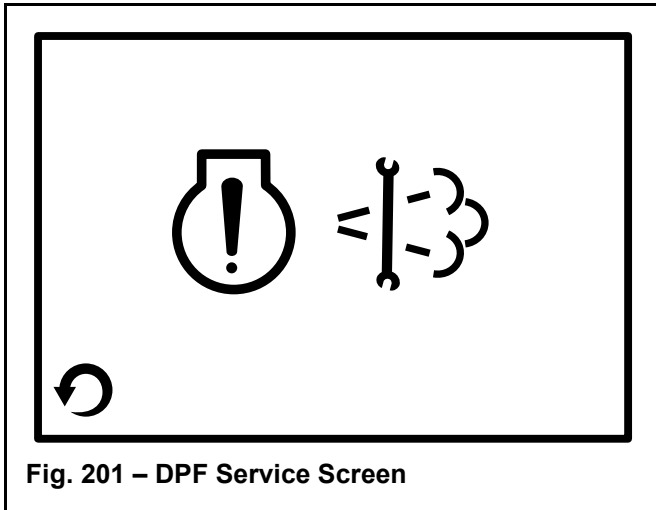

Fig. 201 – DPF Service Screen

**NOTE:** Contact an authorized dealer when the DPF Service screen displays.

## Fuel System Maintenance

### **WARNING**

Diesel fuel is flammable. Keep the machine away from open flames. Do not smoke when refueling or when working on the engine. Stop the engine before fueling.

Wear eye protection. The fuel system is under pressure and fuel could spray out when removing any fuel system component.

Wipe up spills immediately. NEVER use a shop rag to catch draining/leaking fuel. Vapors from the rag are flammable and explosive.

Failure to follow these instructions can cause fire and result in injury or death.

### **CAUTION**

Use only proper types and grades of diesel fuel (See “Fluids/Lubricants Types and Capacities” on page 627).

**NOTICE:** The fuel tank is filled at the factory with United States off-road grade diesel fuel, which is dyed red for identification. It may take several fillings of the fuel tank before the red dye is purged from the fuel system.

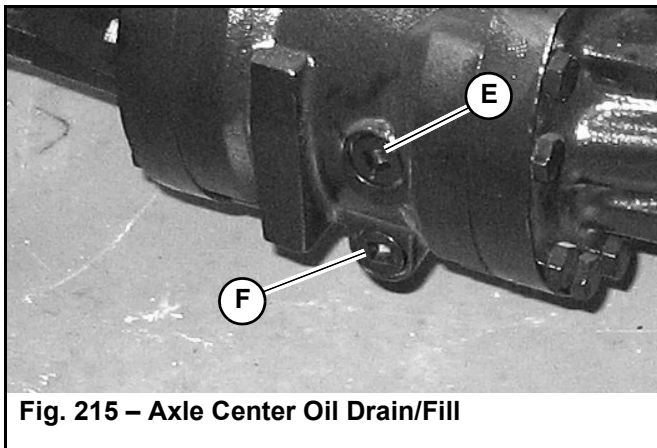

**Fig. 215 – Axle Center Oil Drain/Fill**

**IMPORTANT:** Always dispose of waste oil according to environmental laws or take to a recycling center for proper disposal. DO NOT pour onto the ground or down a drain.

3. Thoroughly clean the area around the axle center drain plugs (F) and slowly loosen and remove the plugs. Allow the oil to completely drain from the axle centers.
4. Thoroughly clean the axle center oil drain plugs. Replace the plugs with new O-rings and tighten the plugs to 70 Nm (51.6 lbf.-ft.).
5. Add oil through the oil fill holes (E) until it reaches the bottom of the holes.

**NOTE:** See “Fluids/Lubricants Types and Capacities” on page 627 for proper oil grade and type. Oil capacity listed is approximate.

6. Thoroughly clean the axle center oil fill plugs (E). Replace the plugs with new O-rings and tighten to 70 Nm (51.6 lbf.-ft.).

## Brake Fluid Reservoir

### Checking/Replenishing Brake Fluid Reservoir Level

1. Park the machine on a level surface and perform the “Mandatory Safety Shutdown Procedure” on page 22.
2. The brake fluid reservoir can be viewed through cutout (Q, Fig. 216) at the front of the cab above the articulation joint.

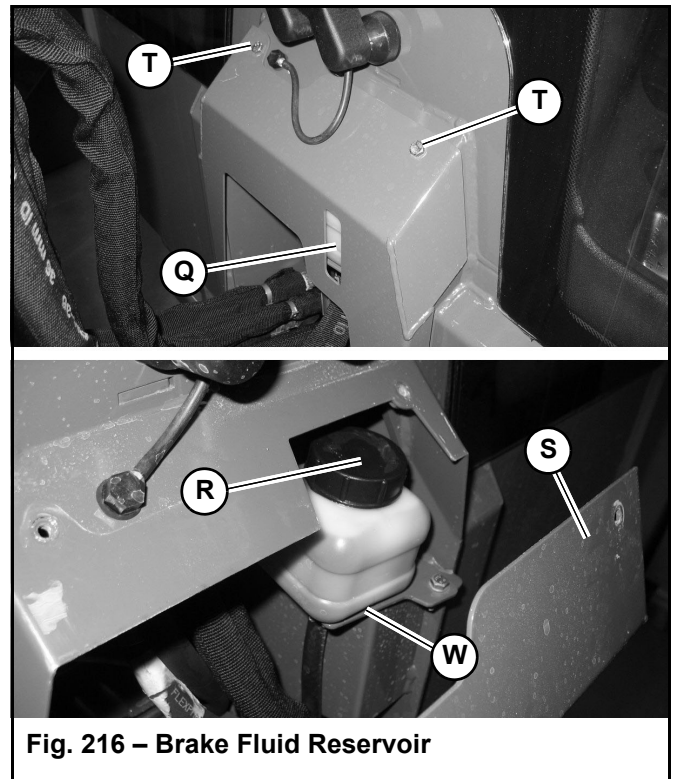

**Fig. 216 – Brake Fluid Reservoir**

**IMPORTANT:** The brake fluid reservoir fluid level should not fall below 1/2 full.

3. To access the brake fluid fill cap (R), remove fasteners (T) and rotate panel (S) forward.
4. Pivot bracket (W) out to access the reservoir. Carefully remove brake fluid reservoir fill cap (S).
5. Add automatic transmission fluid as required. Be careful not to allow dirt to fall into the reservoir.



**Fig. 233 – Left Tail Light Bulbs**

3. Push the replacement bulbs into the sockets and twist to secure in place.
4. Position the tail light lens seal (not shown) onto lens (W). Position and secure tail light lens (W) onto the tail light housing and secure with screws (U).

**NOTE:** For proper weatherproofing, make sure the tail light lens seal is properly positioned to seal the edges of lens (W) against the tail light housing.

## Headlight Bulb Replacements



**BEFORE** beginning this service procedure, shut down the machine according to “Mandatory Safety Shutdown Procedure” on page 22.

1. Remove screws (E, Fig. 234) securing headlight lens bezel (F) and remove lens (D).

**NOTE:** Retain the headlight lens seal (not shown) for re-installation.

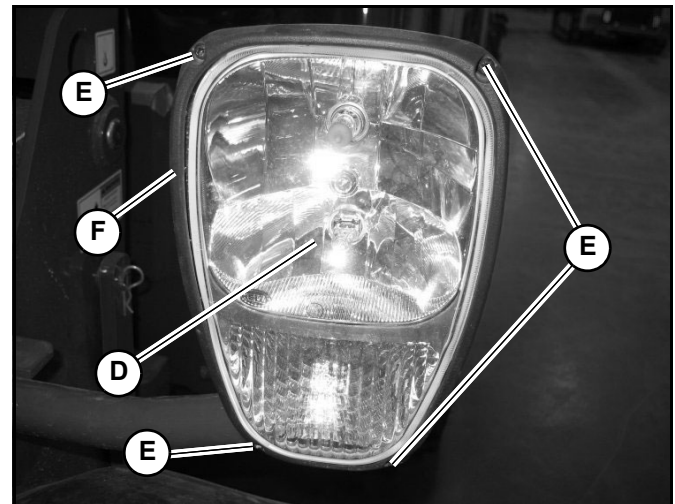

**Fig. 234 – Headlight Lens**

Refer to the following sections for specific bulb replacements:

- High Beams (A, Fig. 235). See “High Beam Bulb Replacement” on page 190.
- Low Beams (M). See “Low Beam Bulb Replacement” on page 190.
- Marker (C). See “Marker Light Bulb Replacement” on page 191.
- Indicator/Hazard (N). See “Indicator/Hazard Bulb Replacement” on page 191.

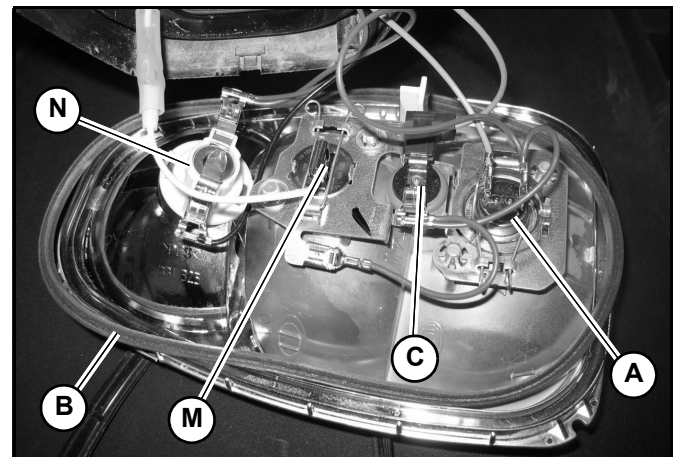

**Fig. 235 – Headlight Bulb Locations**

# Hydrostatic System

## Hydrostatic System General Information

This section includes troubleshooting, testing and adjustment procedures for the hydrostatic tandem pump system.

A hydrostatic tandem pump assembly coupled to the engine drives a variable-displacement hydrostatic drive motor. Refer to “Drive System” on page 223 for more information. Motive power from the motor is transferred to all four wheels through front and rear axles, with the axles connected through a driveshaft.

For detailed information on pump and motor internal repairs, refer to the following Manitou service manuals:

- Danfoss H1 Pump Service Manual [Manitou # 50940483]
- Danfoss H1B Motor Service Manual [Manitou # 50940482]

**NOTE:** Refer to “Hydraulic Drive Motor” on page 226 for additional information about drive motor service.

6. Connect electrical connectors (E, Fig. 269) to the top and bottom of the piston pump solenoid.

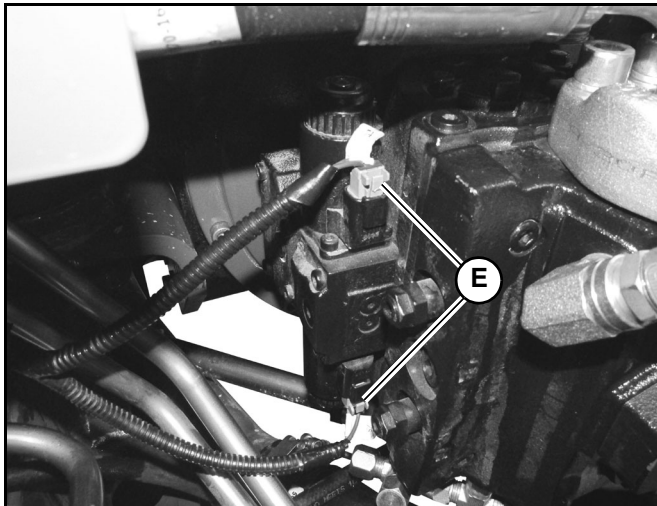

**Fig. 269 – Piston Pump Solenoid**

7. Remove the caps and plugs and secure hoses (F, Fig. 270) to the bottom of the piston pump. Tighten securely.

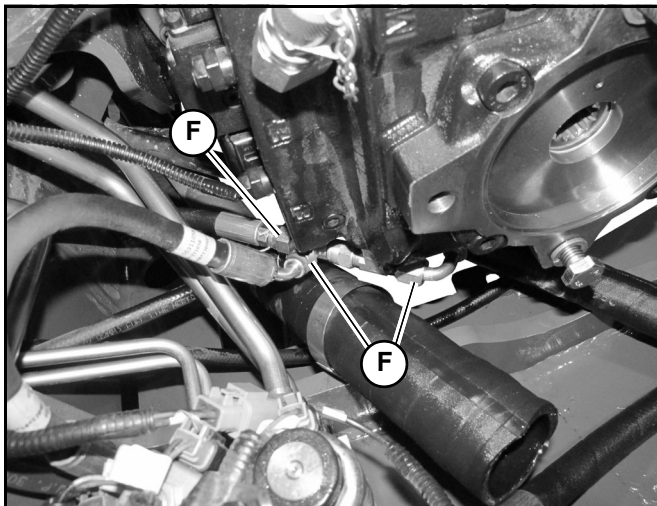
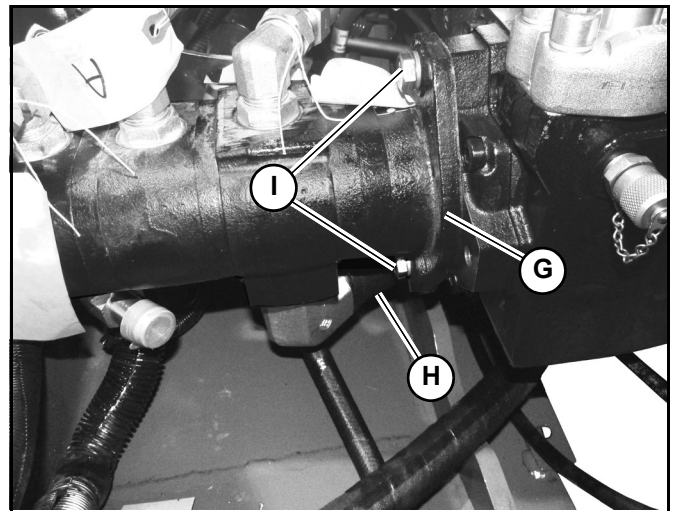

**Fig. 270 – Piston Pump Bottom Connections**

8. Lubricate the O-ring for gear pump (G, Fig. 271) with hydraulic oil.

**NOTE:** Work the larger suction hose (H) onto the gear pump while positioning the pump on the machine.

**IMPORTANT:** To avoid O-ring damage, slide the gear pump straight in-line onto the piston pump.



**Fig. 271 – Gear Pump Installation**

**NOTE:** Slide the hose clamp onto hose (H) before connecting the hose to the gear pump.

9. Remove the caps and plugs and install hose (H) on the gear pump while installing the gear pump onto the piston pump. Secure the gear pump on the piston pump with screws (I) and washers. Tighten screws securely.

**NOTE:** Slide hose clamps onto hoses (J) before connecting the hoses to the gear pump.

10. Remove the caps and plugs and secure hoses (J, Fig. 272) to the bottom of the gear pump. Tighten hose clamps securely.

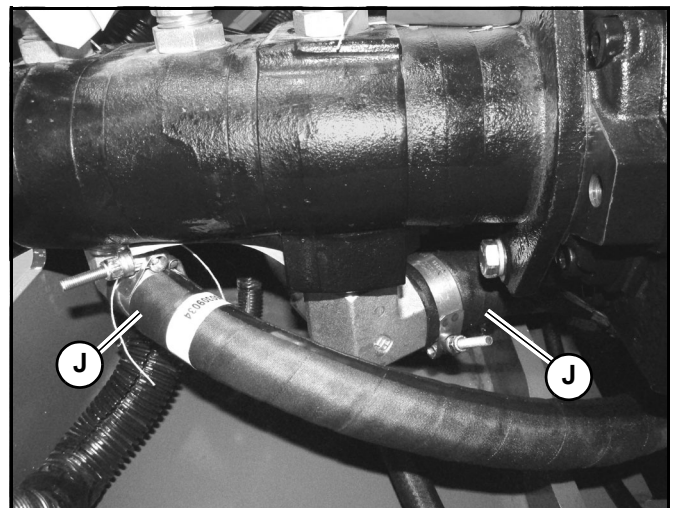

**Fig. 272 – Gear Pump Bottom Connections**

19. Turn the battery disconnect switch to the ON position.

## **WARNING**

Never use your hands to search for hydraulic fluid leaks; use a piece of paper or cardboard to find leaks. Escaping fluid under pressure can be invisible and can penetrate the skin, causing serious injury. If any fluid is injected into your skin, see a doctor at once. Injected fluid **MUST** be surgically removed, or gangrene may result.

## **WARNING**

When the engine is running, components in the engine compartment rotate. Keep well away from all moving parts and be sure that no loose clothing can become caught in the rotating components.

20. Start the engine and allow it to run for a minute or two.
21. Stop the engine and check for hydraulic leaks. Tighten/repair as required.
22. Replace the engine access panels (S, Fig. 302) and secure with hardware (R).

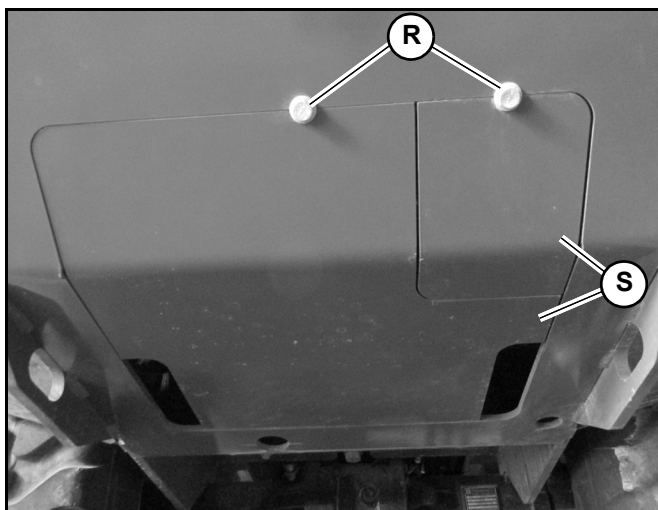

Fig. 302 – Engine Access Panels

23. Secure left access panel (U, Fig. 303) using screws (T). Tighten securely.

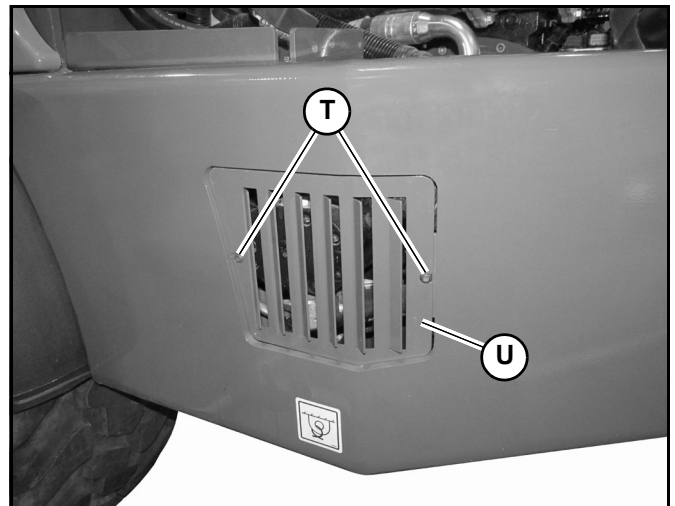

Fig. 303 – Left Access Panel

24. Install the engine cover according to “Engine Cover Removal/Replacement” on page 431.

## Hydrostatic Pump Drive Coupling Removal and Installation

### **WARNING**

**BEFORE** beginning this service procedure, shut down the machine according to “Mandatory Safety Shutdown Procedure” on page 22.

1. Remove the hydrostatic pump according to the pump removal procedure on page 204 (600 series / MLA-6) or page 211 (700 Series / MLA-7 / MLA-T).

- Remove nuts (J, Fig. 312) and disconnect drive shaft (I) from the rear axle.

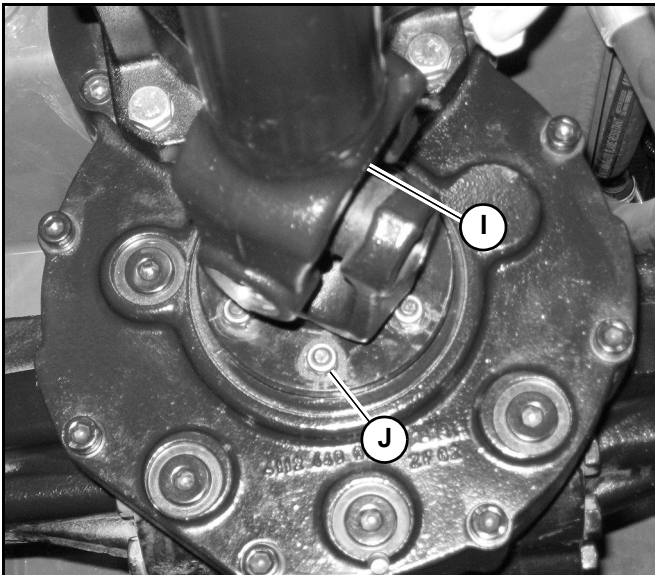

**Fig. 312 – Drive Shaft Connection to Rear Axle**

- Replace nuts (K, Fig. 313) onto rear axle studs (L) to protect threads and prevent loss.

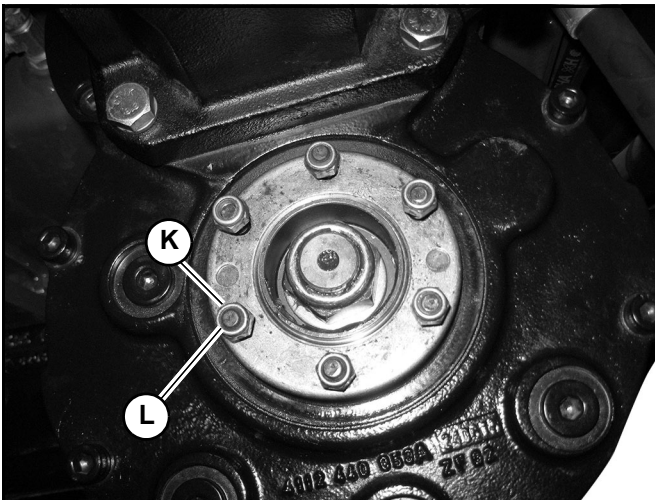

**Fig. 313 – Nuts Replaced on Rear Axle Studs for Storage**

- Disconnect wiring harness connector (M, Fig. 314) from the hydraulic motor.

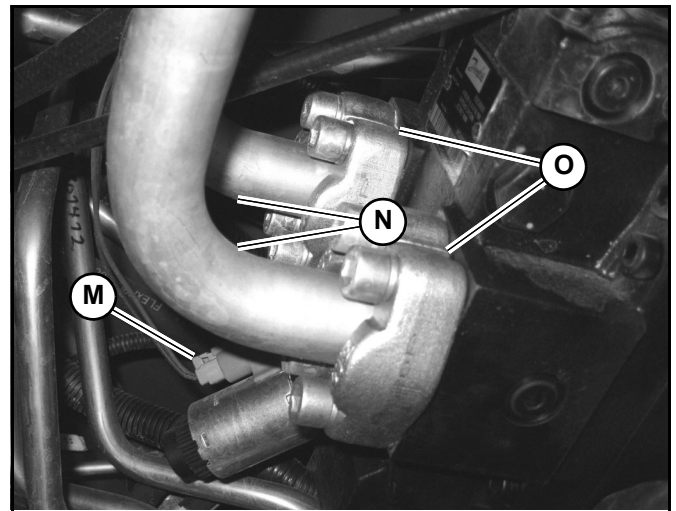

**Fig. 314 – Wiring Harness Connector/Hydraulic Tubes Removal**

- Remove split flanges (O). Remove hydraulic directional drive tubes (N) from the hydraulic motor. Cap and plug openings to prevent drive system contamination.
- Attach an appropriate lifting device (Z, Fig. 315) to the hydraulic motor.

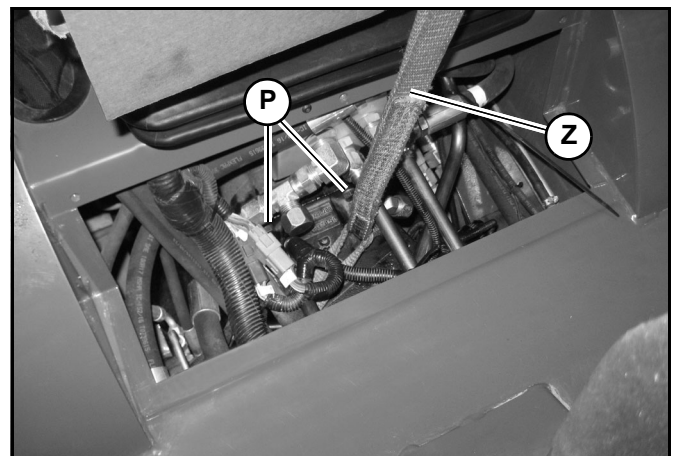

**Fig. 315 – Top Screws Securing Hydraulic Motor**

11. Remove eight nuts (P, Fig. 346) from rear axle studs (Q).

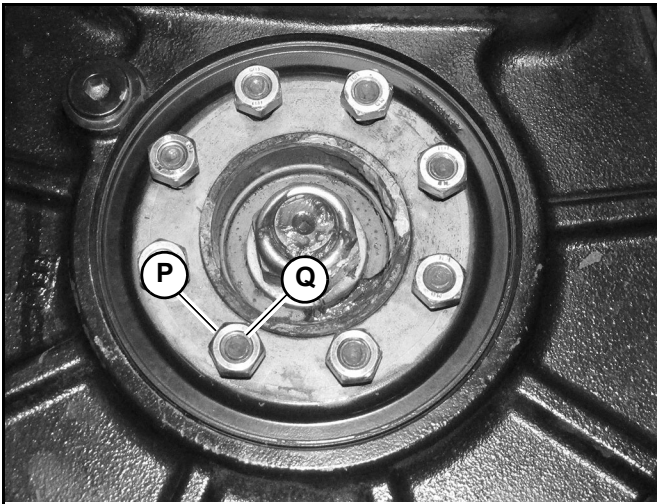

**Fig. 346 – Nuts Stored on Rear Axle Studs**

12. Apply Loctite® 262 or equivalent to nuts (S). Secure drive shaft (R, Fig. 346) to the rear axle using nuts (S). Tighten nuts to 25 Nm (18 ft-lbs.).

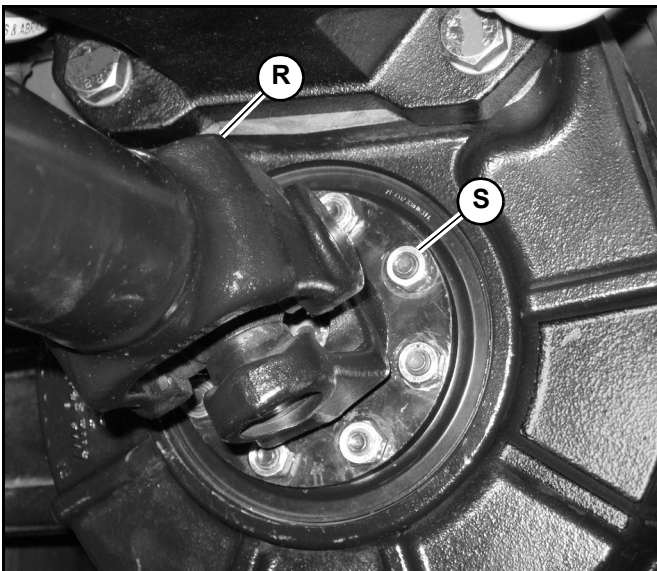

**Fig. 347 – Drive Shaft to Rear Axle**

13. Remove the caps and plugs and secure hydraulic motor drain hose (T, Fig. 348) to the hydraulic motor. Tighten securely.

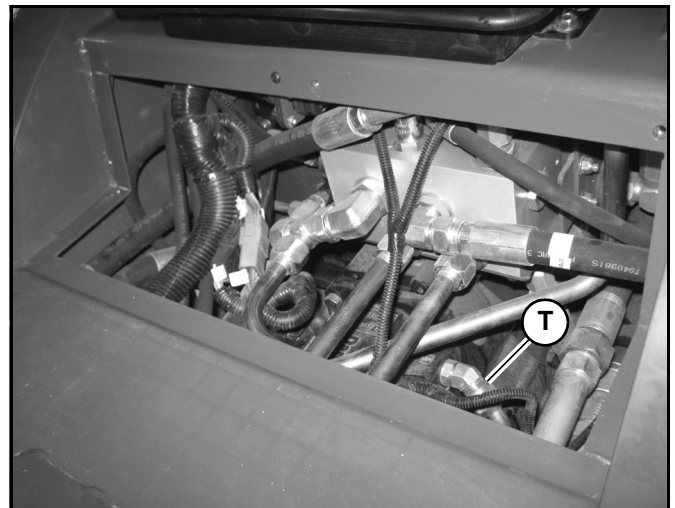

**Fig. 348 – Hydraulic Motor Drain Hose**

14. Plug wire harness connectors (U, V and W, Fig. 349) to the top of the hydraulic motor.

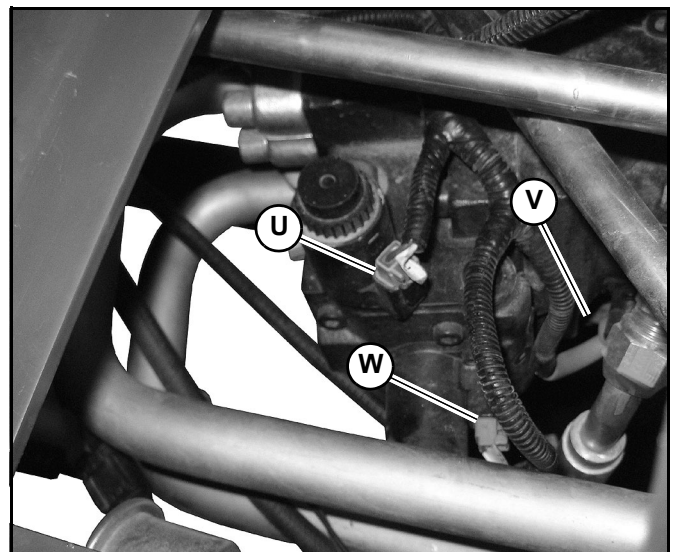

**Fig. 349 – Top Wire Harness Connectors**

# Hydraulic System

## Hydraulic System General Information

This section includes troubleshooting, testing, removal, installation and adjustment procedures for hydraulic system components.

Power for the wheel drive motors is provided by a hydrostatic axial piston pump.

Power for load arm functions and auxiliary hydraulics is provided by a gear pump.

An auxiliary hydraulics system with connections at the attachment hitch, and optionally on the back of the machine, is provided for attachment hookup.

Refer to “Fluids/Lubricants Types and Capacities” on page 627 for recommended hydraulic fluids and capacities. Refer to “Maintenance Schedule” on page 147 for recommended fluid and filter change intervals.

For pump or control valve internal repair information, contact the Manitou Americas and/or refer to the manufacturer’s service manual for the specific hydraulic component.

Refer to “Hydrostatic System” on page 199 for information about the drive pump.

Refer to “Hydraulic System Troubleshooting” on page 304 and “Hydrostatic Travel Drive System Troubleshooting” on page 221 for potential hydraulic system problems, possible causes and remedies.

If a specific hydraulic/hydrostatic system problem is not listed in the troubleshooting section on page 221, contact the Manitou Americas Service Department.

If a problem occurs, don’t overlook simple causes. Malfunctions can be caused by something as simple as low fluid level in the hydraulic reservoir.



## CAUTION

**DO NOT attempt to service or repair major hydraulic system components unless authorized to do so. Unauthorized repairs may void the warranty.**

## General Hydraulic Service Notes



## WARNING

**Make sure the hydraulic oil has cooled before servicing the hydraulic equipment.**

**Relieve pressure from the hydraulic system before servicing the hydraulic equipment.**

- Plug/cap open hydraulic connections to prevent contamination.
- Wipe oil from components so it will not be mistaken for an oil leak.
- Do not damage plating on cylinder rods.
- Remove/replace cylinders with rods fully retracted.
- Bleed air after installing hydraulic cylinders. Refer to “Bleeding Air After Cylinder Installation” on page 280.
- When installing components, clean joint surfaces. Wind sealing tape securely, leaving a space of a thread or two from the tip of the screw. The tape should overlap itself approximately 12 mm (1/2 in.).

## Hydraulic System Diagrams

- Refer to the following pages in this section for diagrams common to all machines and for non-telescopic machines.
- Refer to Telescopic Load Arm starting on page 479 for diagrams specific to telescopic machines.

## Non-Telescopic Power-a-Tach Hydraulics

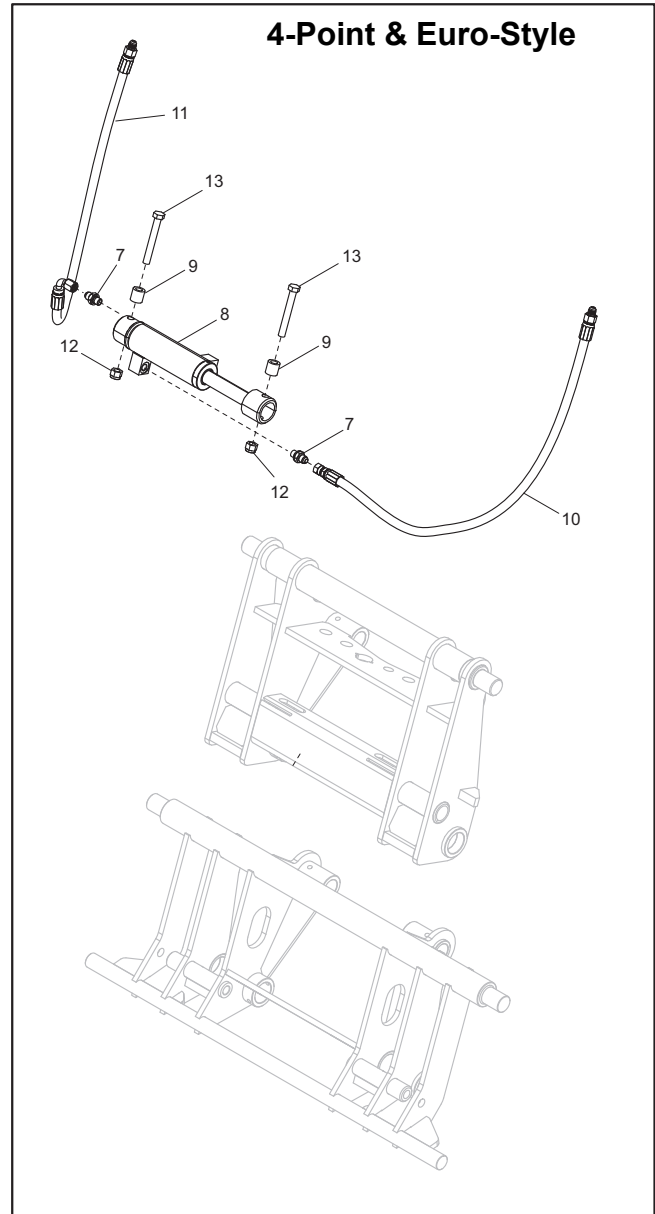
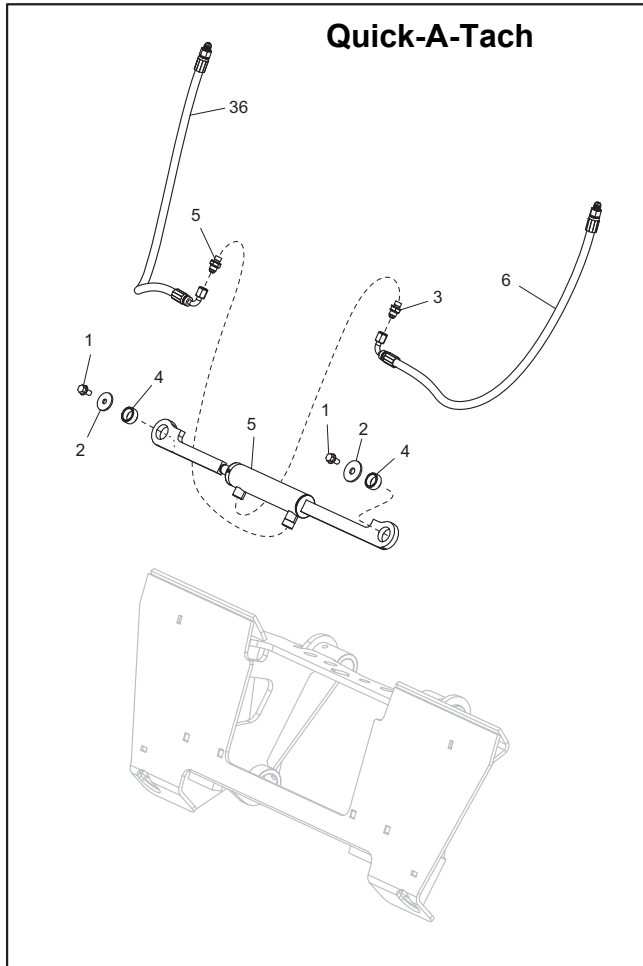

1	Screw
2	Flatwasher
3	Fitting
4	Spacer
5	Quick-A-Tach Cylinder
6	Hose
7	Fitting
8	Quick-A-Tach Cylinder
9	Spacer
10	Hose
11	Hose
12	Locknut
13	Screw

5. If necessary, loosen and remove port relief valves (N, Fig. 375). Clean off any debris.

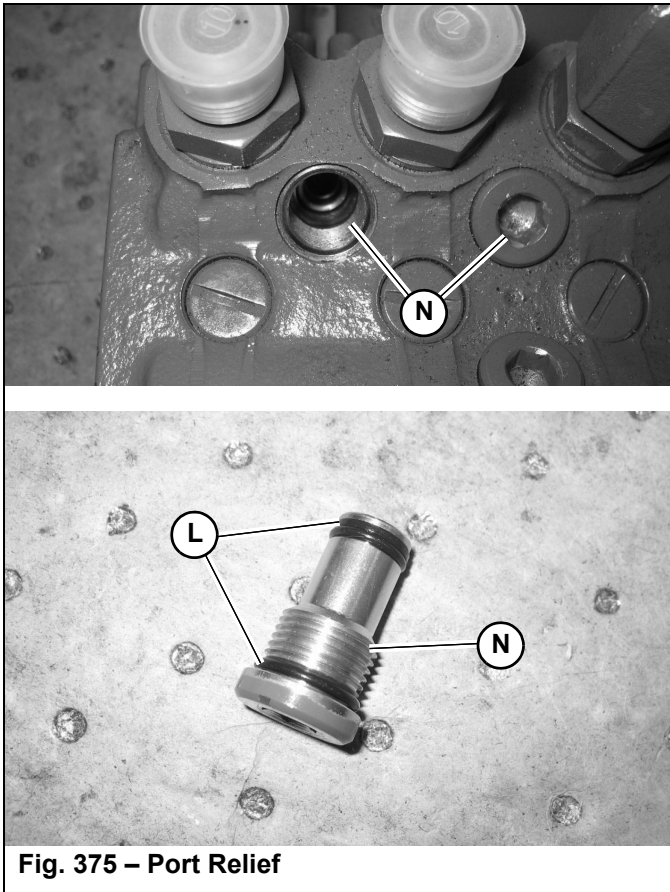

6. Inspect port relief(s) (N) and O-rings (L) for wear/damage. Replace if necessary.

## Installation

Install the relief valves in the control valve in the reverse order of removal.

## Non-Telescopic Machines Tilt/Lift Cylinder Tests

### Non-Telescopic Machines Tilt Cylinder Drift Test

1. Connect a bucket or other attachment to the attachment hitch.
2. Raise the load arm approximately 1 meter (3 ft.). Release the multi-function joystick and make sure it is in the neutral position.
3. Tilt the attachment hitch all the way back.

4. Stop the engine and turn the ignition key to the OFF position.

If the bucket (or other attachment) drifts down, check the tilt cylinder for external leakage. If external leakage is found, replace the leaking cylinder seals. If no external leakage is found, check the tilt cylinder for internal leakage according to “Non-Telescopic Machines Tilt Cylinder Internal Leakage Test” on page 269.

The maximum allowable tilt cylinder circuit drifting with a loaded bucket is 10 mm (0.4 in.) of cylinder extension within 15 minutes.

If the drifting exceeds the allowable maximum, check the tilt cylinder for external/internal leakage:

- a. If external leakage is evident, tighten, repair, and/or replace components as necessary to eliminate leakage.
- b. If no external leakage is evident, check the tilt cylinder for internal leakage according to the following section: “Non-Telescopic Machines Tilt Cylinder Internal Leakage Test.”

### Non-Telescopic Machines Tilt Cylinder Internal Leakage Test

**IMPORTANT:** This procedure requires two people.

1. Engage the load arm tilt support (Z, Fig. 376) according to “Engage Tilt Support” on page 110.

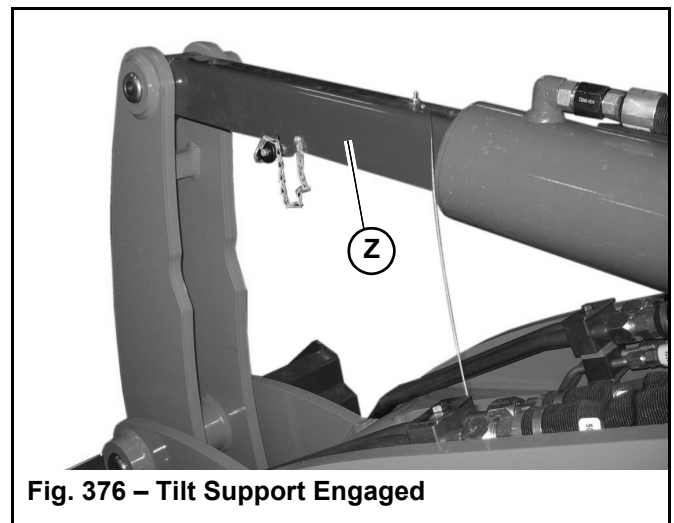

## Telescopic Machines Extension Cylinder Drift Test

1. Start the machine. If necessary, attach a bucket to the machine.
2. Place a load of 900 Kg (2000 lbs.) into the bucket.
3. Fully retract the load arm.
4. Position the load arm so it is angled 20° down from horizontal. Release the multi-function joystick and make sure it is in the neutral position.
5. Stop the engine and turn the ignition key to the OFF position.
6. Observe whether the load arm drifts forward over a period of time.

There should be no measurable extension cylinder circuit drifting after 2 hours.

If any measurable drifting is found, check the extension cylinder for external/internal leakage:

- a. If external leakage is evident, tighten, repair, and/or replace components as necessary to eliminate leakage.
- b. If no external leakage is evident, check the lift cylinder for internal leakage according to the following section: “Telescopic Machines Lift Cylinder Internal Leakage Test.”

## Telescopic Machines Extension Cylinder Internal Leakage Test

**IMPORTANT:** This procedure requires two people.

1. Fully retract the load arm and lower it to the ground.
2. Complete the “Mandatory Safety Shutdown Procedure” on page 22.

**IMPORTANT:** To prevent contamination, ALWAYS clean the area around hydraulic fittings before disconnecting hydraulic hoses or tubes.

3. Disconnect the hydraulic hose (X, Fig. 387) from the tube (B). Cap or plug the hose (X).

**IMPORTANT:** Caps/plugs MUST BE able to withstand full hydraulic pressure.

**NOTE:** The tube (B) is connected to the base end port of the load arm extension cylinder. The connection for hose (X) is located inside the front chassis between the load arm pillars.

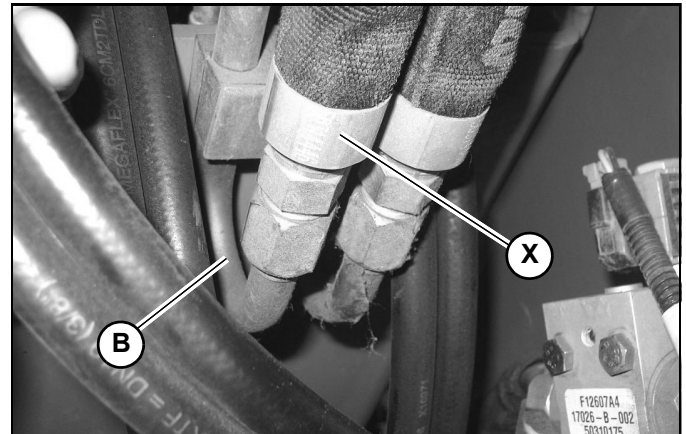

Fig. 387 – Extension Cylinder Base End Hose

4. Connect a hose to the tube (B) and run the other end of the hose into a suitable container to allow the oil to drain.
  5. Sit in the operator’s seat and start the engine. Have an assistant watch the hose in the container.
  6. Move the rocker switch on the multi-purpose joystick to the left to retract the load arm and the extension cylinder.
- NOTE:** A small amount of oil will exit the hose initially, but if the seals in the cylinder need replacement, oil will continue to flow.
7. Shut off the engine.
  8. Remove caps/plugs and reconnect the hose (X) to the tube (B).

**NOTE:** If external or internal leakage is not seen and the load arm extension still drifts, check the following:

- Hydraulic leaks between the control valve and the load arm extension cylinder.
- Main control valve malfunction.
- Refer to “Hydraulic System Troubleshooting” on page 304.

5. For an alternate test, have an assistant directly test the solenoid on the valve as follows:
  - a. Remove fasteners (L, Fig. 412) securing kick plate (M) under the operator's seat. Remove the kick plate.

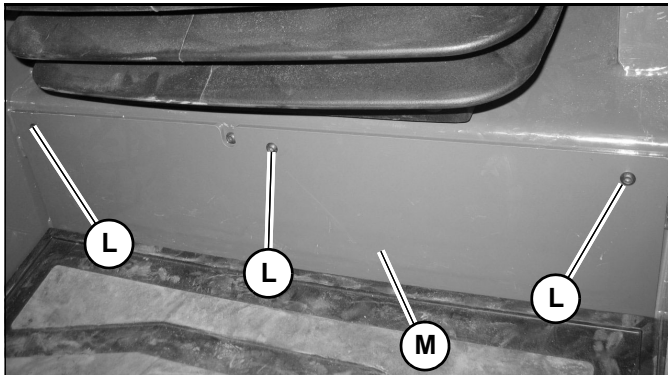

**Fig. 412 – Kick Plate Removal**

- b. Move a thin strip of steel close to the solenoid coils (T and O, Fig. 413) on the right end of the auxiliary hydraulics valve.
      - An electrical malfunction is indicated if the steel strip IS NOT magnetically attracted to the solenoid coil.
      - If the steel strip IS magnetically attracted to the solenoid coil, the coil operates and the solenoid cartridge may be malfunctioning.
6. Repeat this test with the standard auxiliary rocker switch (F, Fig. 411) fully down:
  - The “Aux Hyd Reverse Output” (K, Fig. 410) indicator should be green.
  - The steel strip should be magnetically attracted to the solenoid coils (S and O, Fig. 413).

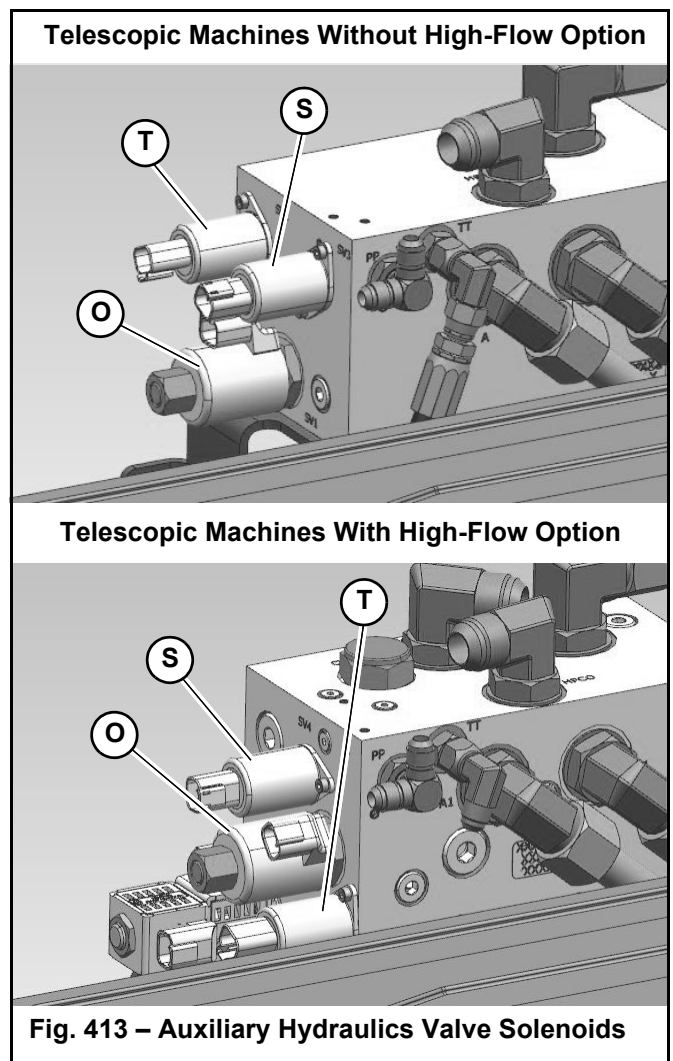

**Fig. 413 – Auxiliary Hydraulics Valve Solenoids**

7. If the auxiliary hydraulics do not latch into continuous operation, test the auxiliary hydraulics latching (continuous flow) function as follows:
        - a. Press the left side of the navigation rocker button (A) until the “INPUTS OUTPUTS 1” screen (Fig. 414) is displayed.

## Hydraglide (Telescopic Machines)

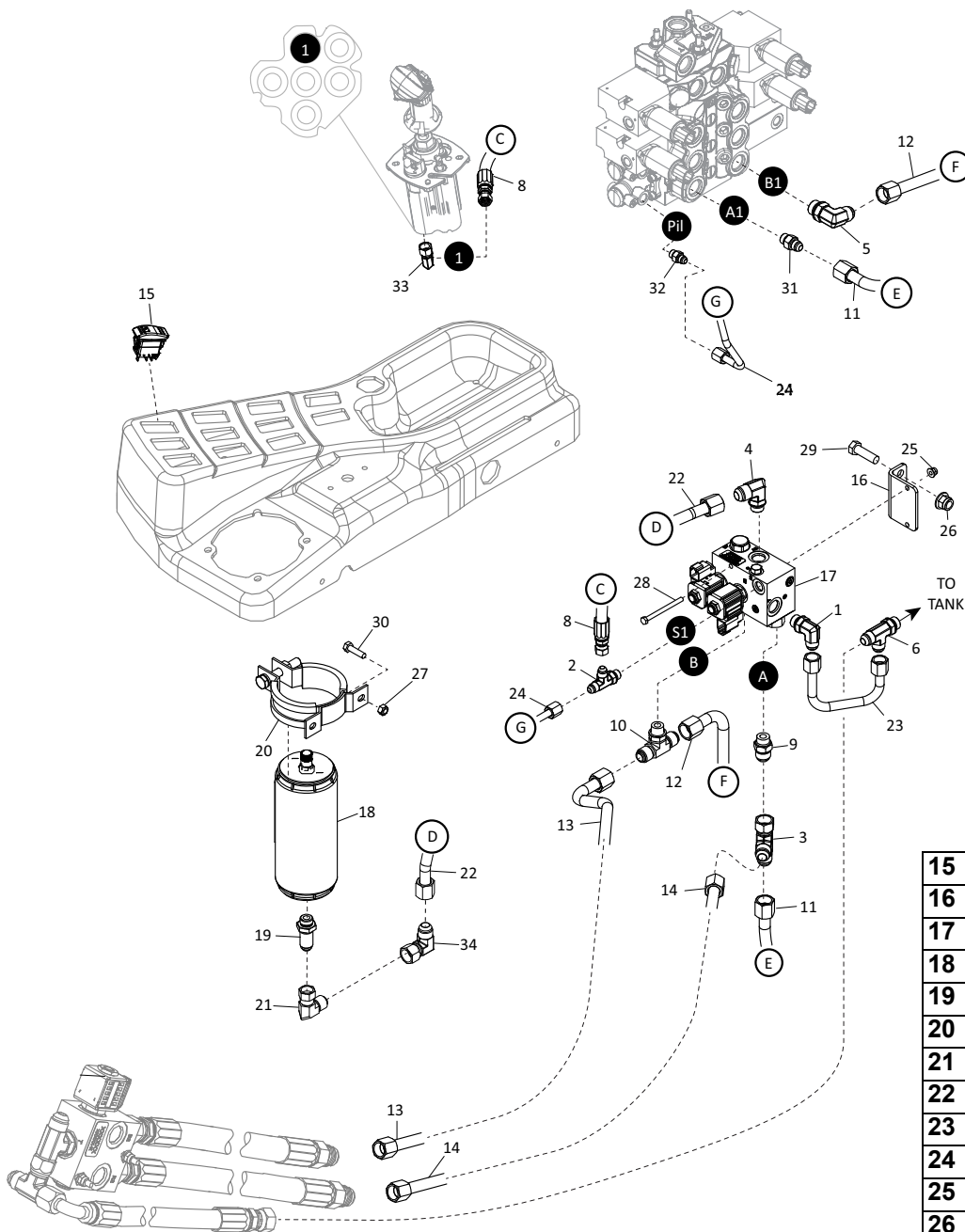

1	90° Fitting
2	Tee Fitting
3	Tee Fitting
4	90° Fitting
5	90° Fitting
6	Tee Fitting

8	Hose
9	Fitting
10	Tee Fitting
11	Tube
12	Tube
13	Tube
14	Tube

15	Switch
16	Bracket
17	Hydraglide Valve
18	Accumulator Piston
19	Fitting
20	Clamp
21	90° Fitting
22	Tube
23	Tube
24	Tube
25	Locknut
26	Locknut
27	Locknut
28	Capscrew
29	Capscrew
30	Capscrew
31	Fitting
32	Fitting
33	90° Fitting
34	90° Fitting

Hydraulic Schematic — Standard Auxiliary Hydraulics (Telescopic Machines)

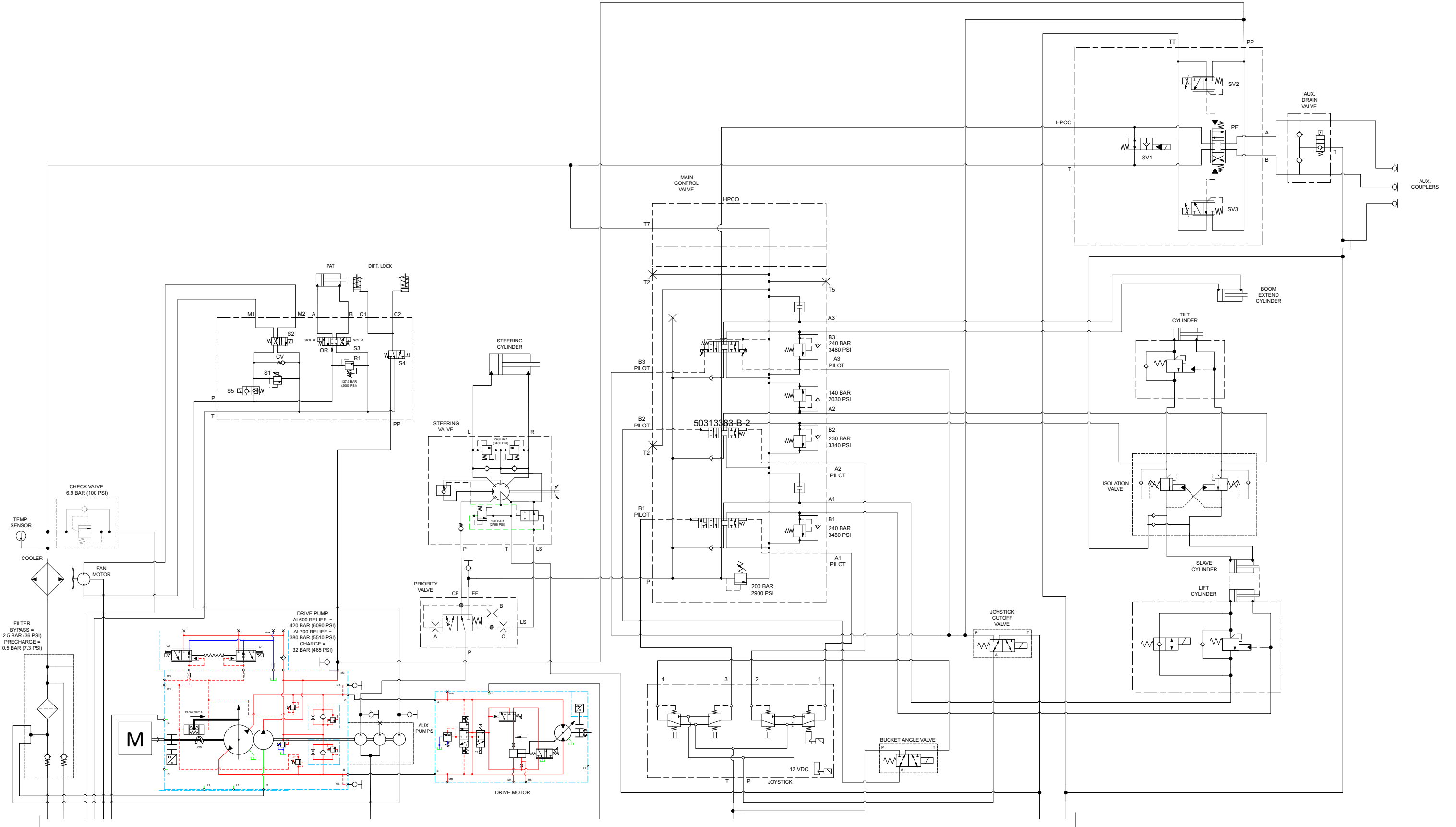

50326127-A-1

CLICK HERE TO **DOWNLOAD** THE COMPLETE MANUAL

- Thank you very much for reading the preview of the manual.
- You can download the complete manual from: [www.heydownloads.com](http://www.heydownloads.com) by clicking the link below



- Please note: If there is no response to CLICKING the link, please download this PDF first and then click on it.

CLICK HERE TO **DOWNLOAD** THE COMPLETE MANUAL

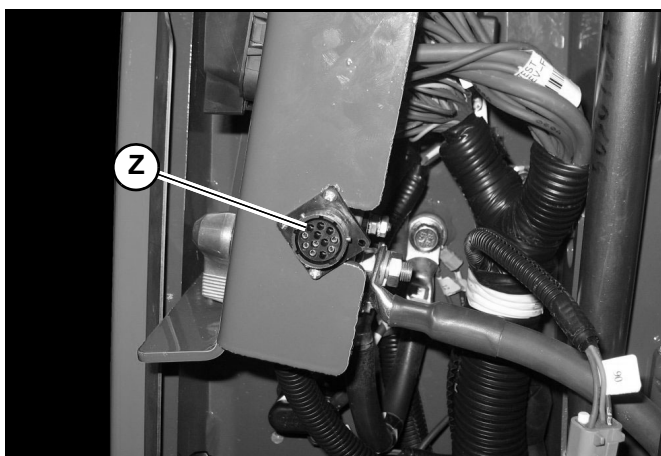

Fig. 461 – Deutz SerDia Data Connector

## CAN System Service Software

### Danfoss Service Tool (Plus+1) Software

**IMPORTANT:** The Service adapter harness [Manitou part # 50291685] and the Communication Harness Kit [Manitou part # 203907] are required to use the Danfoss Service Tool.

**NOTE:** A download link for the PLUS+1® GUIDE Service Tool software is included with the Communication Harness Kit [Manitou part # 203907].

The Danfoss Plus+1 service tool provides access to drive system error code history and allows for firmware updates.

**NOTE:** Only active drive system error codes are shown on the multi-function display.

For additional information about the PLUS+1 service tool, its features and functionality, visit the Danfoss website at:  
<http://powersolutions.danfoss.com/Home/>

### Multi-Function Display Service Software Update/Pass Code Reset

The multi-function display service software is used for periodic software updates for the multi-function display.

**NOTE:** When the pass code feature is enabled, a PIN code is required before the machine can be started. If forgotten, the PIN code is reset by updating the multi-function display software.

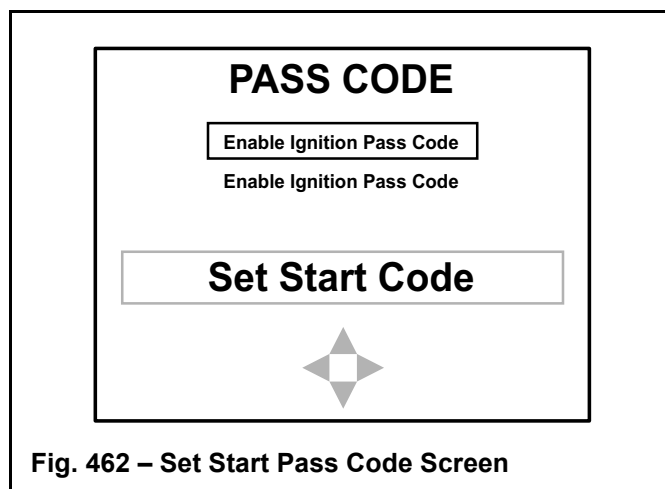

Fig. 462 – Set Start Pass Code Screen

**IMPORTANT:** Service adapter harness [Manitou part # 50291685] and service display kit [Manitou part # 50292454] are required to update the multi-function display software.

## Operation Functional Detail

**Table 32: Operation Functional Detail**

Function	Inputs/Conditions	Outputs/Actions	Malfunction Causes
Throttle Speed Adjust	<ul style="list-style-type: none"> <li>Engine is running (engine oil pressure detected).</li> <li>Throttle speed analog input value is between 0.5-4.5 VDC.</li> </ul> <p><b>NOTE:</b> Both hand and foot throttles are included in throttle input.</p>	<ul style="list-style-type: none"> <li>Throttle speed CAN message is sent to engine ECU.</li> </ul> <p>Throttle speed is set to the highest of the two values between the hand and foot throttles.</p> <p><b>NOTE:</b> If the throttle speed analog input value is out-of-range, a CAN error code is generated.</p>	<ul style="list-style-type: none"> <li>Throttle control malfunction.</li> <li>Electrical fault (switch/components/connections).</li> <li>Component malfunction.</li> <li>CAN error/communication fault (out-of-range).</li> </ul> <p><b>NOTE:</b> Engine-specific diagnostic software may be needed for in-depth troubleshooting.</p>
Fuel Level Sender	<ul style="list-style-type: none"> <li>Ignition switch in ON/RUN position.</li> <li>Fuel level sender resistance: 31.5-34.5 ohms full; 236.5-245.7 ohms.</li> </ul>	Fuel level CAN data broadcast and appears on the display.	<ul style="list-style-type: none"> <li>Electrical fault (switch, components, connections or battery).</li> <li>CAN error/communication fault.</li> </ul>
Engine Coolant Temperature	<ul style="list-style-type: none"> <li>Ignition switch in ON/RUN position.</li> <li>Engine coolant temperature sender resistance:                             <ul style="list-style-type: none"> <li>68° F (20° C) - 2.45 (+0.14/-0.13) ohms.</li> <li>176° F (80° C) - 0.318 ± 0.008 ohms.</li> <li>212° F (100° C) - 0.1836 ohms.</li> </ul> </li> </ul>	Engine coolant temperature CAN data broadcast and appears on the display.	<ul style="list-style-type: none"> <li>Electrical fault (switch, components, connections or battery).</li> <li>CAN error/communication fault.</li> </ul>

**Table 37: Warning Indicators Functional Detail**

Function	Inputs/Conditions	Outputs/Actions	Malfunction Causes
Low Engine Oil Pressure Alarm Activation	<ul style="list-style-type: none"> <li>• Engine is running (engine oil pressure detected).</li> <li>• Low engine oil pressure CAN message (engine error code 100-x) broadcast by engine ECU.</li> </ul>	<ul style="list-style-type: none"> <li>• Low engine oil pressure indicator symbol appears on the display.</li> <li>• A 5 second audible alarm sounds.</li> </ul> <p><b>NOTE:</b> May cause engine de-rating condition.</p>	<ul style="list-style-type: none"> <li>• Electrical fault (components/connections).</li> </ul> <p><b>Important:</b> Low engine oil pressure indicates a serious engine malfunction. Shut down the engine immediately if the low engine oil pressure indicator symbol appears on the display. Correct the problem before running the machine. Damage to the engine may result if the engine is run with low oil pressure.</p> <ul style="list-style-type: none"> <li>• CAN error/communication fault.</li> </ul>
Check Engine Alarm Activation	<ul style="list-style-type: none"> <li>• Engine is running (engine oil pressure detected).</li> <li>• Check engine CAN message (various engine error codes) broadcast by engine ECU.</li> </ul>	<ul style="list-style-type: none"> <li>• Check engine indicator symbol appears on the display.</li> </ul> <p><b>NOTE:</b> Various engine error codes may be broadcast. May cause engine de-rating condition.</p>	<ul style="list-style-type: none"> <li>• Electrical fault (components/connections).</li> </ul> <p><b>NOTE:</b> Refer to “Error Codes” on page 599.</p> <ul style="list-style-type: none"> <li>• CAN error/communication fault.</li> </ul>

# Electrical Control System

**Table 40: CAN System Inputs/Outputs Screen 1**

Item	Input/Output	Description	Status	Condition
Marker Light SW	<ul style="list-style-type: none"> <li>ON/OFF digital electrical Marker Light SW signal (12VDC ON/OFF) from control lever switch input to MCU.</li> <li>CAN "Marker Light SW" message output from MCU to display.</li> <li>CAN "Marker Light Output" message output from MCU to display.</li> <li>ON/OFF digital electrical signal (12VDC ON/OFF) from MCU to marker lights.</li> </ul>	<p>Marker light switch position status.</p> <p><b>NOTE:</b> The switch on the end of the control lever controls marker and road lights. Rotating the switch to the first position (one notch counter-clockwise) turns the marker lights ON.</p>	Green	<ul style="list-style-type: none"> <li>Light switch on the end of the control lever is in the marker lights ON position.</li> <li>Marker lights activated.</li> </ul>
			Blank	<ul style="list-style-type: none"> <li>Light switch on the end of the control lever is in the marker lights IS NOT in the ON position.</li> <li>Marker lights deactivated.</li> </ul>
High Flow Reverse SW	<ul style="list-style-type: none"> <li>ON/OFF digital electrical High Flow Reverse SW signal (12VDC ON/OFF) from high flow reverse switch on switch panel to MCU.</li> <li>CAN "High Flow Reverse SW" and "High Flow Reverse Output" messages output from MCU to display.</li> <li>ON/OFF High Flow Reverse Output digital electrical signal (12VDC ON/OFF) from MCU to high-flow auxiliary hydraulics valve.</li> </ul>	<p>Auxiliary hydraulics high-flow reverse switch on switch panel ON/OFF position status</p>	Green	<ul style="list-style-type: none"> <li>Auxiliary hydraulics high-flow toggle switch (on switch panel) reverse position is closed (reverse flow ON).</li> <li>GREEN High Flow Reverse Output on INPUTS OUTPUTS 2 screen.</li> </ul>
			Blank	<p>Auxiliary hydraulics high-flow toggle switch (on switch panel) reverse position is open (reverse flow OFF).</p>
High Flow Forward SW	<ul style="list-style-type: none"> <li>ON/OFF digital electrical High Flow Forward SW signal (12VDC ON/OFF) from high flow forward switch on switch panel to MCU.</li> <li>CAN "High Flow Forward SW" and "High Flow Forward Output" messages output from MCU to display.</li> <li>ON/OFF digital electrical High Flow Forward Output signal (12VDC ON/OFF) from MCU to high-flow auxiliary hydraulics valve.</li> </ul>	<p>Auxiliary hydraulics high-flow forward switch on switch panel ON/OFF position status.</p>	Green	<ul style="list-style-type: none"> <li>Auxiliary hydraulics high-flow toggle switch (on switch panel) forward position is closed (forward flow ON).</li> <li>GREEN High Flow Forward Output on INPUTS OUTPUTS 2 screen.</li> </ul>
			Blank	<p>Auxiliary hydraulics high-flow toggle switch (on switch panel) forward position is open (forward flow OFF).</p>

**Table 41: CAN System Inputs/Outputs Screen 2**

Item	Input/Output	Description	Status	Condition
Attach Lock Output	<ul style="list-style-type: none"> <li>• ON/OFF digital electrical signal (12VDC ON/OFF) from attachment lock button on keypad to MCU.</li> <li>• CAN “Attach Lock PB” message output from MCU to display.</li> <li>• CAN “Attach Lock Output” message output from MCU to display.</li> <li>• ON/OFF digital electrical signal (12VDC ON/OFF) from MCU to attachment lock valve solenoid.</li> </ul>	<p>Attachment hitch lock CAN message/digital electrical output signal status.</p> <p><b>NOTE:</b> Attachment hitch lock output is interrupted if the seat switch is open (seat not occupied) for 1.5 seconds or longer.</p>	Green	<ul style="list-style-type: none"> <li>• Attachment hitch lock button on keypad pressed.</li> <li>• Attachment hitch lock moves into locked position.</li> </ul>
			Yellow	Short circuit (overload) or open circuit (no load) in quick attach lock valve solenoid electrical circuit.
			Blank	<ul style="list-style-type: none"> <li>• Attachment hitch lock button on keypad IS NOT pressed.</li> <li>• Attachment hitch lock does not move.</li> </ul>
Attach Unlock Output	<ul style="list-style-type: none"> <li>• ON/OFF digital electrical signal (12VDC ON/OFF) from attachment unlock button on keypad to MCU.</li> <li>• CAN “Attach Unlock PB” message output from MCU to display.</li> <li>• CAN “Attach Unlock Output” message output from MCU to display.</li> <li>• ON/OFF digital electrical signal (12VDC ON/OFF) from MCU to attachment unlock valve solenoid.</li> </ul>	<p>Attachment hitch unlock CAN message/digital electrical output signal status.</p> <p><b>NOTE:</b> Attachment hitch unlock output is interrupted if the seat switch is open (seat not occupied) for 1.5 seconds or longer.</p>	Green	<ul style="list-style-type: none"> <li>• Attachment hitch unlock button on keypad pressed.</li> <li>• Attachment hitch lock moves into unlocked position.</li> </ul>
			Yellow	Short circuit (overload) or open circuit (no load) in quick attach unlock valve solenoid electrical circuit.
			Blank	<ul style="list-style-type: none"> <li>• Attachment hitch unlock button on keypad IS NOT pressed.</li> <li>• Attachment hitch lock does not move.</li> </ul>

# Electrical Control System

**Table 42: CAN System Inputs/Outputs Screen 3**

Item	Input/Output	Description	Status	Condition
Dome Light Output	<ul style="list-style-type: none"> <li>D igital electrical signal (12VDC ON/OFF) from seat switch and/or keypad button to MCU.</li> <li>CAN “Dome Light Output” message output from MCU to display.</li> <li>ON/OFF digital electrical signal (12VDC ON/OFF) sent to dome light.</li> </ul>	Dome light activates when seat is occupied and/or keypad button pressed. Dome light deactivates after 30 secs. if seat is unoccupied, or if engine is started.	Green	Seat switch closed (ON) and/or keypad button pressed.
			Yellow	Short circuit (overload) or open circuit (no load) in dome light electrical circuit.
			Blank	Seat switch open (OFF) and/or blown fuse/electrical fault.
Right Turn Output	<ul style="list-style-type: none"> <li>ON/OFF right turn digital electrical signal (12VDC ON/OFF) from control lever switch to MCU.</li> <li>CAN “Right Turn SW” message output from MCU to display.</li> <li>CAN “Right Turn Output” message output from MCU to display.</li> <li>ON/OFF digital electrical signal (12VDC ON/OFF) from MCU to right turn indicator lights.</li> </ul>	Road lights right turn indicator CAN message/digital electrical output signal status.	Green	<ul style="list-style-type: none"> <li>Control lever forward in the right turn signal ON position.</li> <li>Right turn indicator lights activated.</li> </ul>
			Yellow	Short circuit (overload) or open circuit (no load) in right indicator light electrical circuit.
			Blank	<ul style="list-style-type: none"> <li>Control lever NOT forward in the right turn signal ON position.</li> <li>Right turn indicator lights deactivated.</li> </ul>
Left Turn Output	<ul style="list-style-type: none"> <li>ON/OFF left turn digital electrical signal (12VDC ON/OFF) from control lever switch to MCU.</li> <li>CAN “Left Turn SW” message output from MCU to display.</li> <li>CAN “Left Turn Output” message output from MCU to display.</li> <li>ON/OFF digital electrical signal (12VDC ON/OFF) from MCU to left turn indicator lights.</li> </ul>	Road lights left turn indicator CAN message/digital electrical output signal status.	Green	<ul style="list-style-type: none"> <li>Control lever back in the left turn signal ON position.</li> <li>Left turn indicator lights activated.</li> </ul>
			Yellow	Short circuit (overload) or open circuit (no load) in left indicator light electrical circuit.
			Blank	<ul style="list-style-type: none"> <li>Control lever NOT back in the left turn signal ON position.</li> <li>Left turn indicator lights deactivated.</li> </ul>

## 600 Series / MLA-6 Engine Electrical

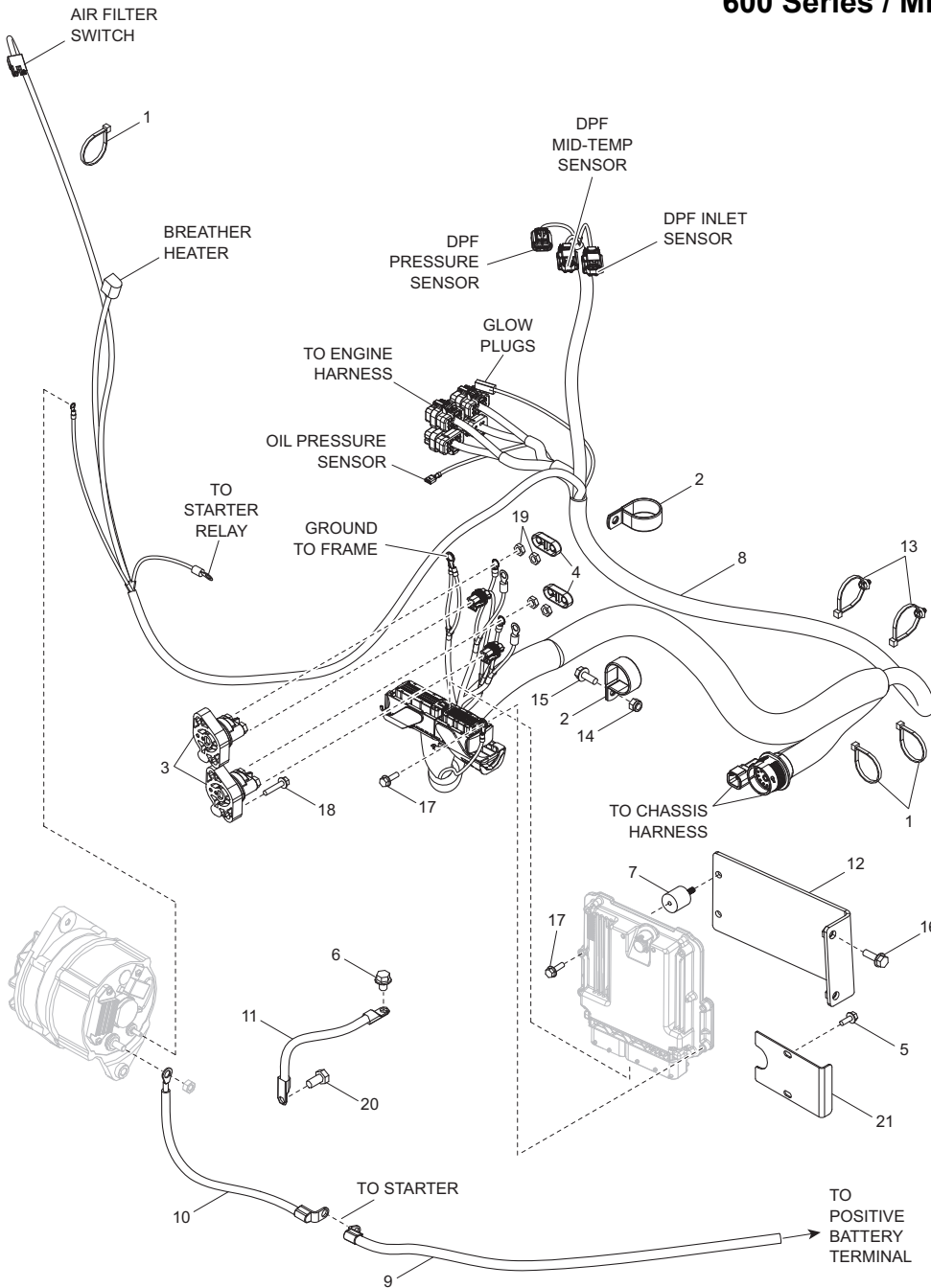

1	Tie
2	Hose Clamp
3	Solenoid
4	Cover
5	Screw
6	Screw
7	Isolator
7	Isolator
8	Engine Wire Harness
9	Positive Cable

10	Alternator Wire
11	Ground Cable
12	ECU Bracket
13	Tie
14	Locknut
15	Screw
16	Screw
17	Screw
17	Screw
18	Screw

19	Nut
20	Screw
21	Plate



Electrical Schematic – Chassis – Rear Frame (2 of 2)

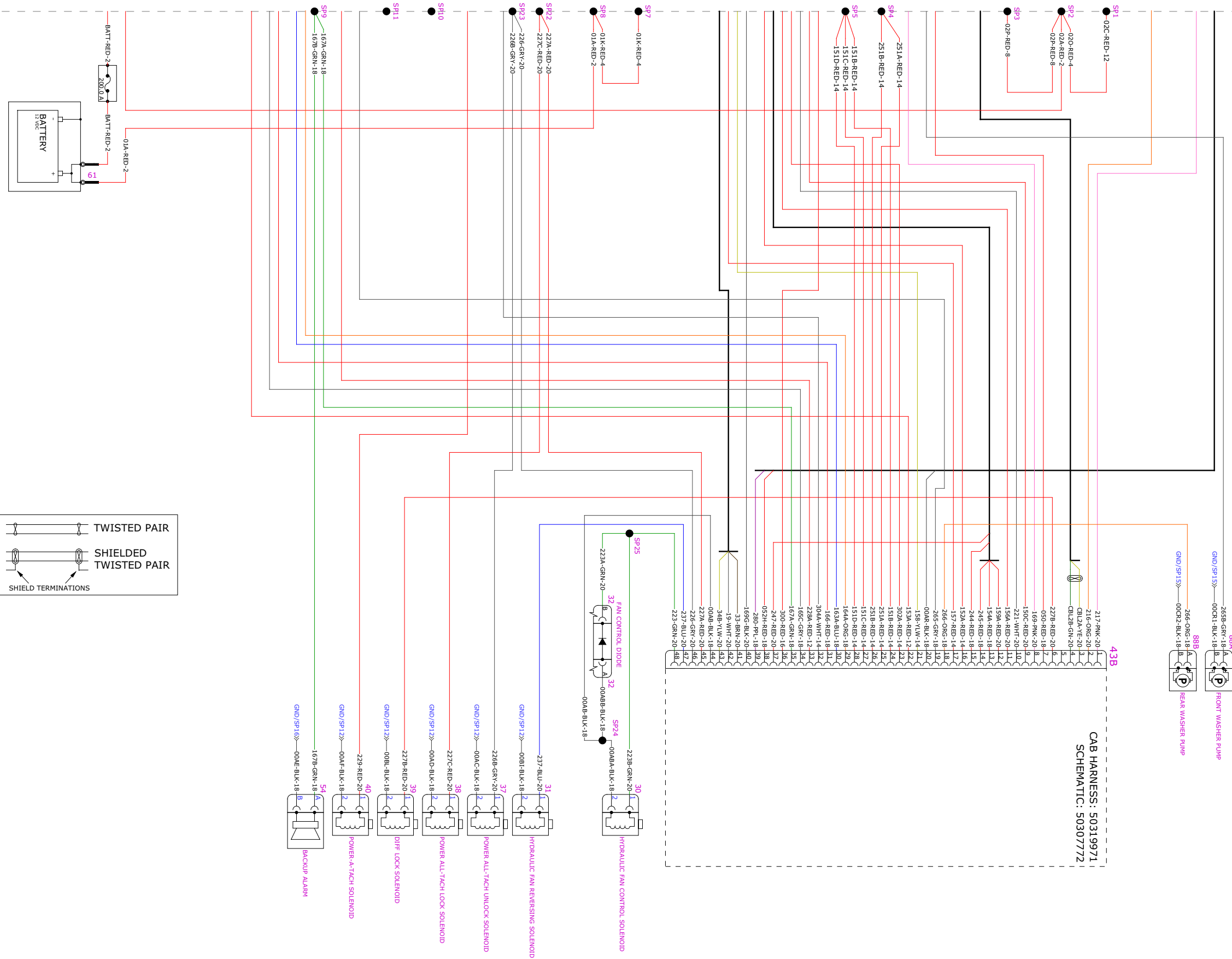

Electrical Schematic — Electrical Auxiliary Circuits

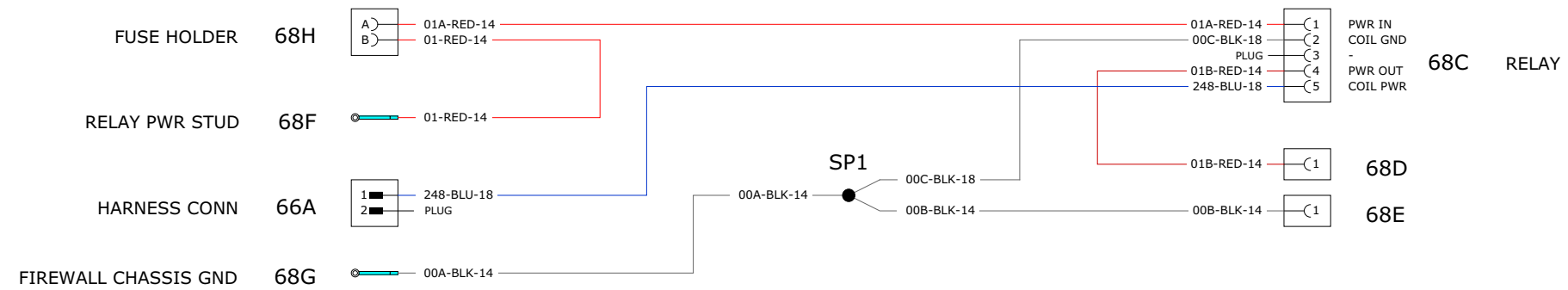

REAR ELECTRICAL AUX HARNESS

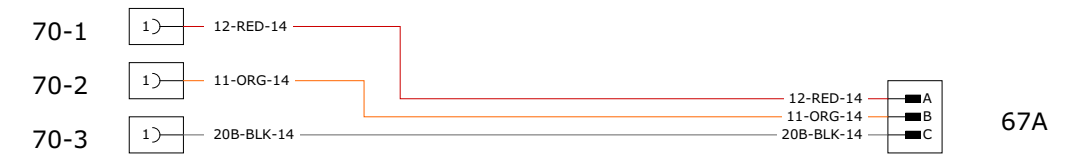

FRONT ELECTRICAL AUX JUMPER HARNESS

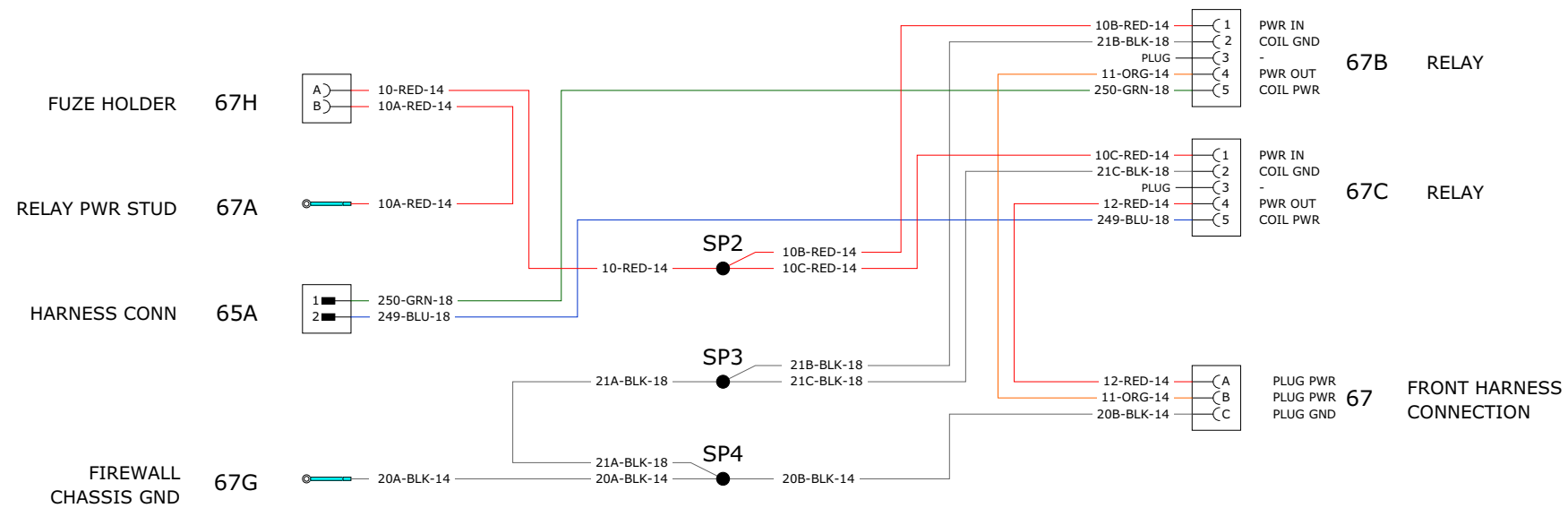

FRONT ELECTRICAL AUX HARNESS

35. Label and disconnect hydraulic filter restriction alarm sender switch connector (D, Fig. 497).

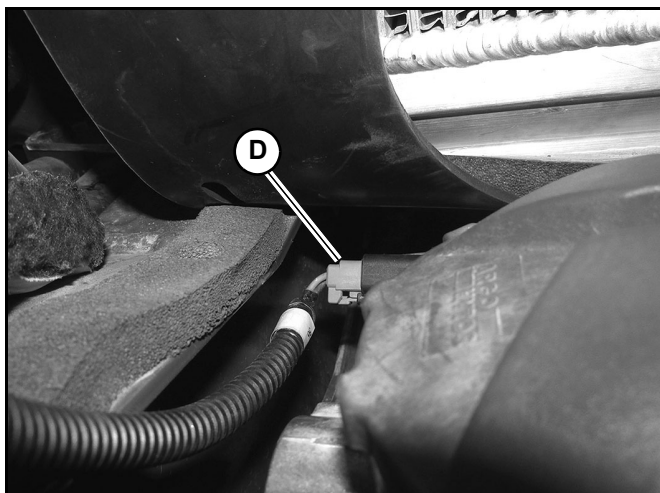

**Fig. 497 – Hydraulic Filter Restriction Alarm Sender Switch Connector**

**IMPORTANT:** *Lift cab/canopy slowly and carefully. Check all disconnection points to ensure all necessary hoses, tubes, wires, and cables have been disconnected and will not be damaged during cab/canopy removal.*

36. Lift cab/canopy slowly and carefully. Pull joystick hydraulic hoses through the hole in the cab/canopy floor.
37. Remove the cab/canopy from the machine. Carefully set the cab/canopy on jack stands or wood blocks.

## **WARNING**

**Position the cab/canopy so it will not tip over. Serious injury and damage can occur if the cab/canopy tips over.**

## Cab/Canopy Installation

### **WARNING**

**Use proper lifting equipment. Lifting the cab/canopy without proper equipment could result in serious personal injury or equipment damage. Keep clear of suspended loads.**

**Never lift with anyone in or on the cab/canopy.**

1. Install M16 lifting eyes (X, Fig. 498) in each of the four threaded holes in the corners of the cab/canopy roof top. Attach a suitable lifting device (Y) to the lifting eyes.

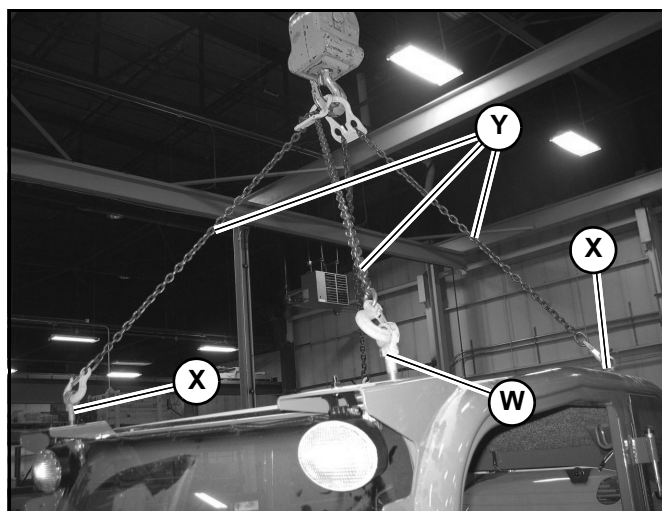
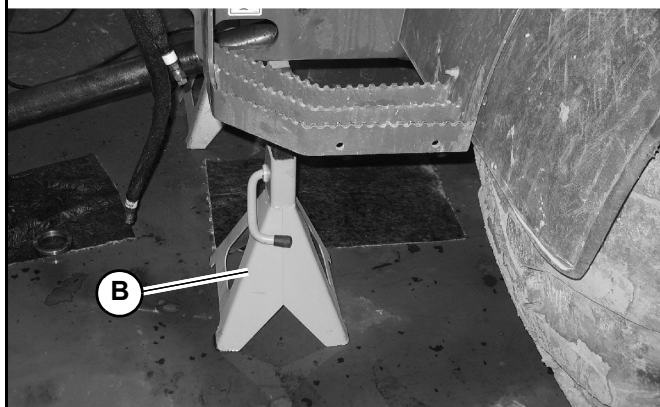
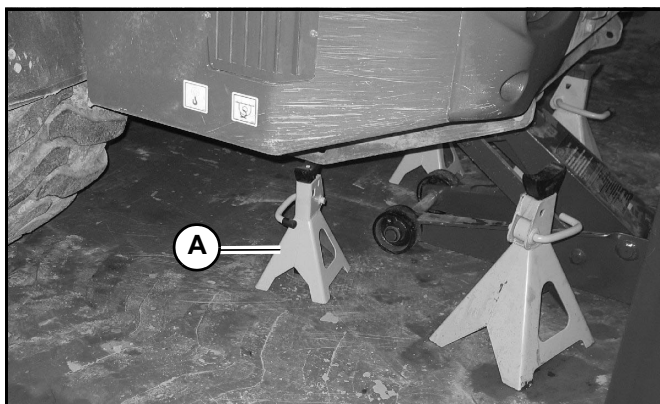

**Fig. 498 – Cab/Canopy Lifting Device**

2. Lift cab/canopy slowly and carefully and position it over the machine.
3. Lower the cab/canopy slowly and carefully to approximately 300 mm (12 in.) above the cab/canopy mounts.
4. Pull the joystick hydraulic hoses through the hole in the cab/canopy floor.

- Place suitable jack stands/wood blocks at the back (A, Fig. 524) and front (B) of the rear chassis.

**NOTE:** Adjust the jack stands (A and B) to keep the rear chassis level and the rear wheels off the ground.



**Fig. 524 – Rear Chassis Jack Stands**

- Lower the rear chassis so it is supported by the jack stands/wood blocks (A and B).
- Release the parking brake.
- Support the front chassis with a properly rated overhead hoist (C, Fig. 525) at the lift points (D) on the front chassis.

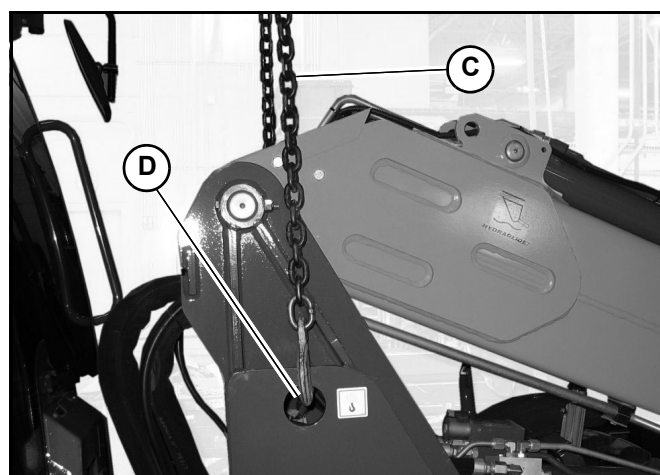

**Fig. 525 – Front Chassis Overhead Hoist**

- Additionally support the front chassis using suitable jack stands/wood blocks (E, Fig. 526).

**NOTE:** The tilt of the front and/or rear chassis may need to be adjusted during this procedure. Parts in the articulation joint can bind depending upon chassis alignment.

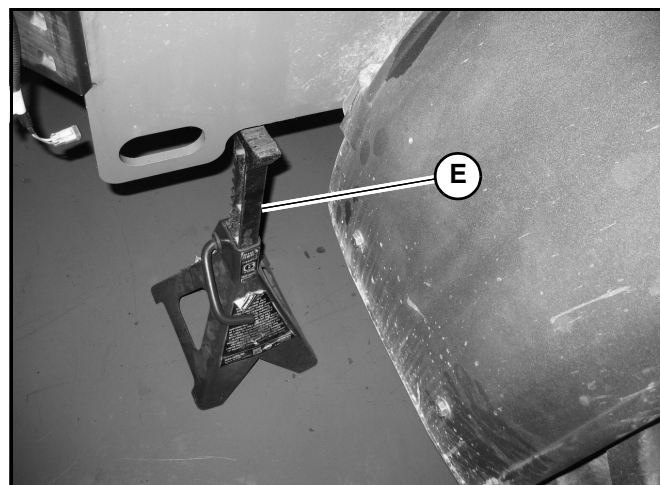
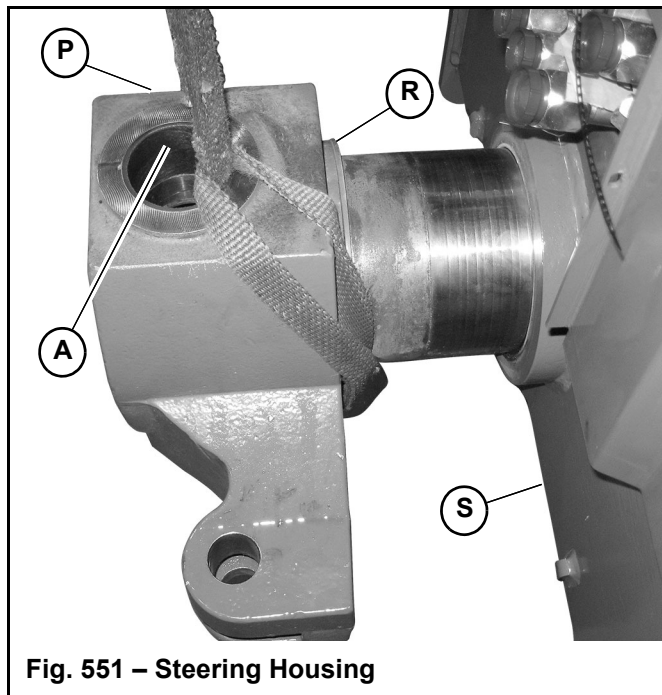

**Fig. 526 – Front Chassis Jack Stands**

## **WARNING**

**DO NOT** use any lifting attachments (slings, chains, etc.) that are damaged or do not have sufficient rated capacity.

**NOTE:** The steering housing (P, Fig. 551) weighs approximately 68 Kg (150 lbs.).



**Fig. 551 – Steering Housing**

1. Attach an appropriate lifting device to the steering housing (P).
2. Slide the thrust washer (R) onto the steering housing shaft.
3. Slide the steering housing (P) into the rear chassis (S).

4. If necessary, strap steering housing (P, Fig. 552) to the rear chassis (S) to aid in the installation of the stop plate (N, Fig. 554).

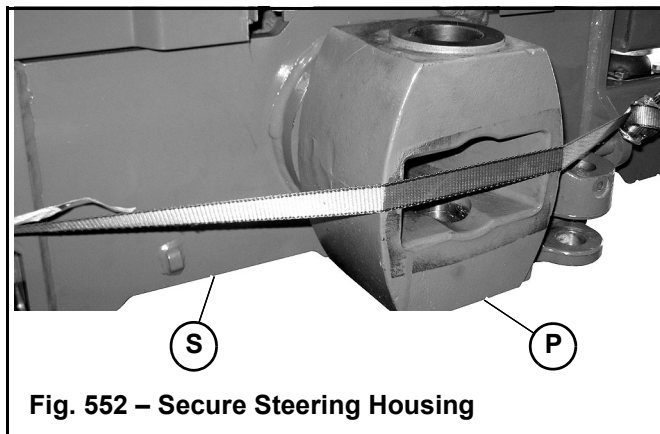

**Fig. 552 – Secure Steering Housing**

5. From underneath the machine, install the thrust washer (O, Fig. 553) onto the end of the steering housing (P).
6. From underneath the machine, install the thrust washer (O, Fig. 553) around the end of the steering housing shaft (P).

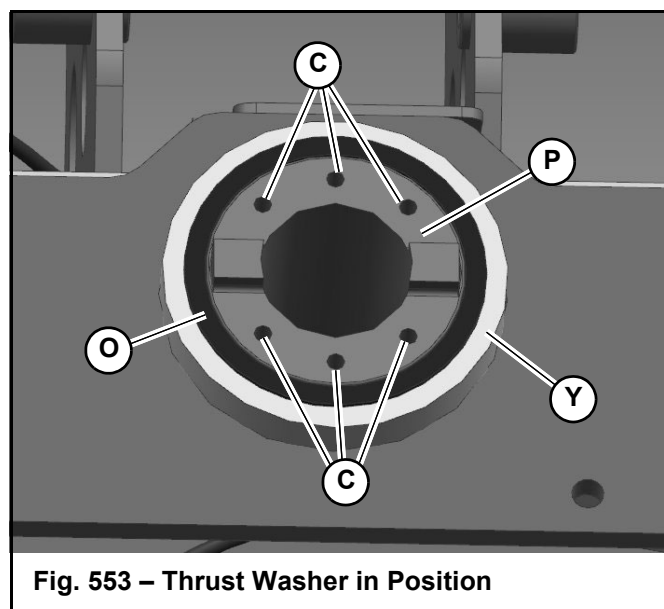
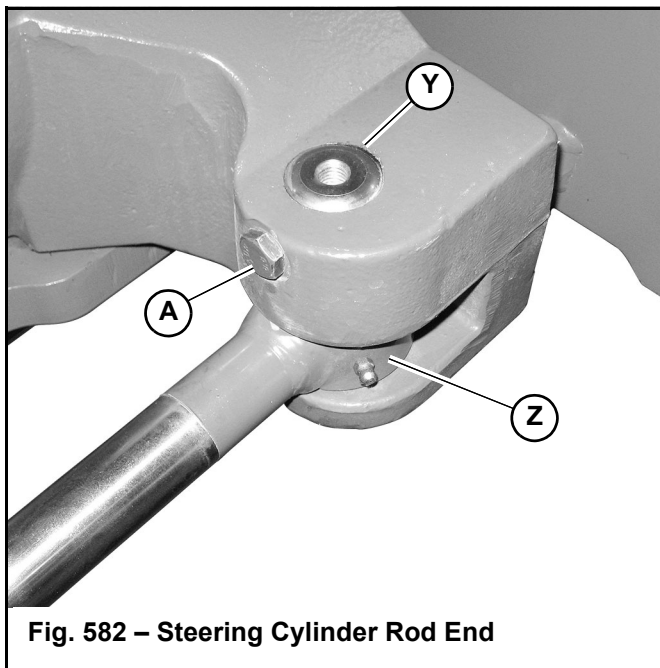

**Fig. 553 – Thrust Washer in Position**

**IMPORTANT:** Make sure the thrust washer (O) is not between the rear face of the housing shaft (P) and the stop plate (M). The thrust washer (O) must be completely and evenly seated around the steering housing shaft (P).

Apply grease to the thrust washer (O) to help hold it to the rear chassis during assembly. Make sure grease does not get into holes (C).

46. Attach steering cylinder rod end (Z, Fig. 582) to the bracket in the steering housing using pivot pin (Y).



47. Fasten the pivot pin (Y) using the screw (A).
48. Remove caps and plugs and connect the hoses (V, Fig. 583) to the steering cylinder.

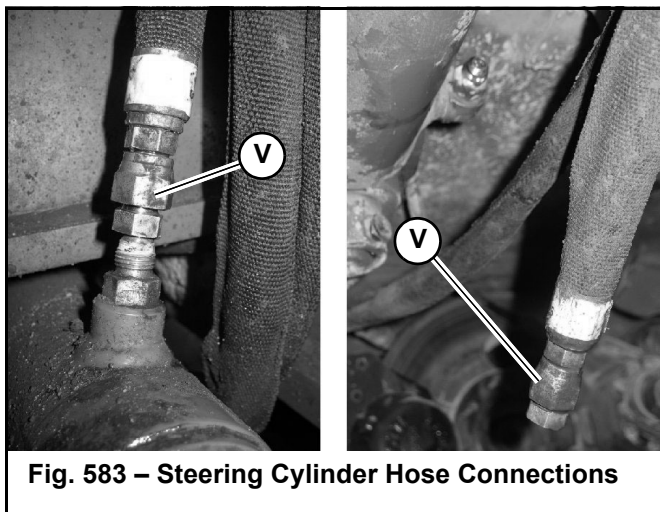

49. Remove the plugs and caps and connect all of the hydraulic hoses (X, Fig. 584) at the articulation joint.

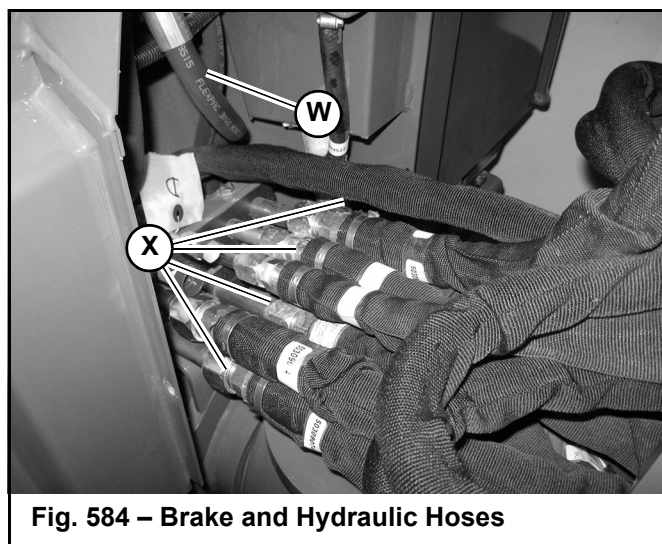

**IMPORTANT:** Connect the hoses (X) in the same locations as noted in step 35 on page 439.

50. Tighten the hoses (X) securely.
51. Remove the plugs and caps and attach the brake hose (W) at the articulation joint. Tighten securely.
52. Attach the articulation joint cover (J, Fig. 585) using fasteners (H and I). Tighten securely.

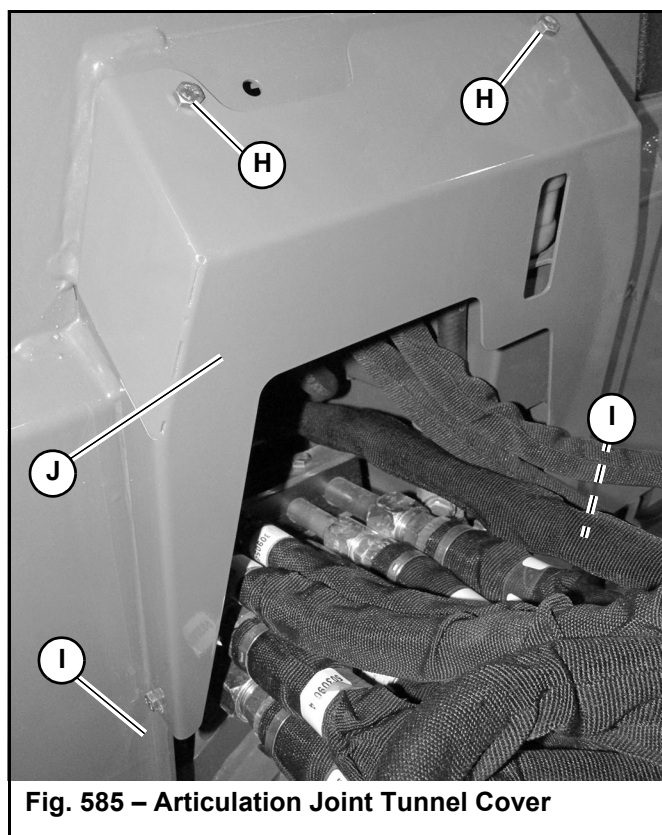

31. Remove screws and nuts (I and H, Fig. 608) securing articulation joint tunnel cover (J). Remove cover (J).

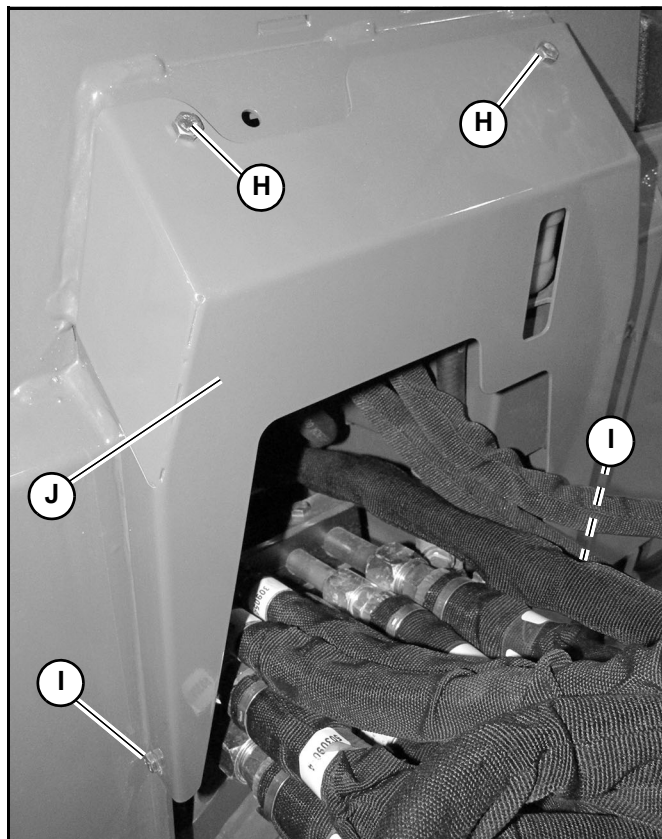

**Fig. 608 – Articulation Joint Tunnel Cover**

**NOTE:** Some hydraulic oil will leak when removing hoses. Provide for catching leaking oil.

32. Disconnect brake hose (W, Fig. 609) at the articulation joint.

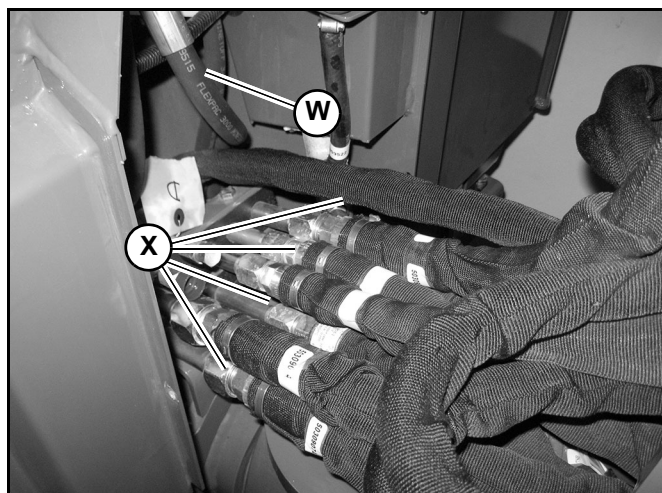

**Fig. 609 – Brake and Hydraulic Hoses**

33. Label and disconnect all hydraulic hoses (X) at the articulation joint. Cap and plug all openings to prevent contamination.

34. Remove screw (A, Fig. 610) and pivot pin (Y) from steering cylinder rod end (Z).

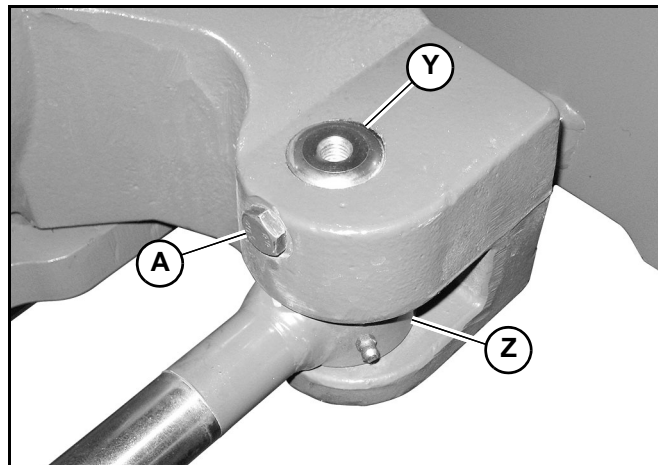

**Fig. 610 – Steering Cylinder Rod End**

35. Disconnect the hoses (V, Fig. 611) from the steering cylinder. Cap/plug all openings to prevent contamination.

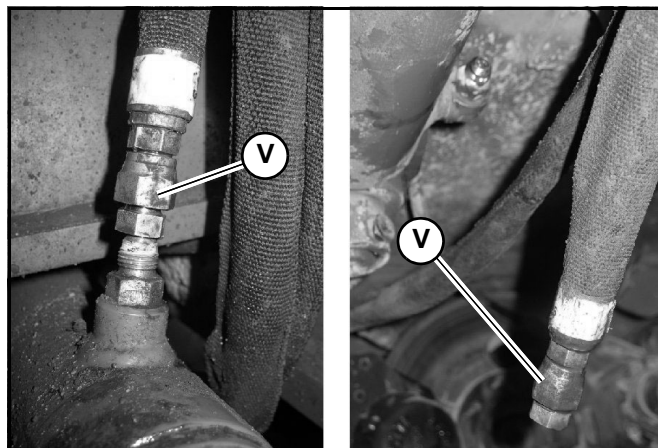

**Fig. 611 – Steering Cylinder Hose Connections**

36. Feed all remaining wires and hoses through the articulation joint toward rear chassis.

28. Pull brake cable (I, Fig. 638) and front chassis harness (J) through articulation joint.

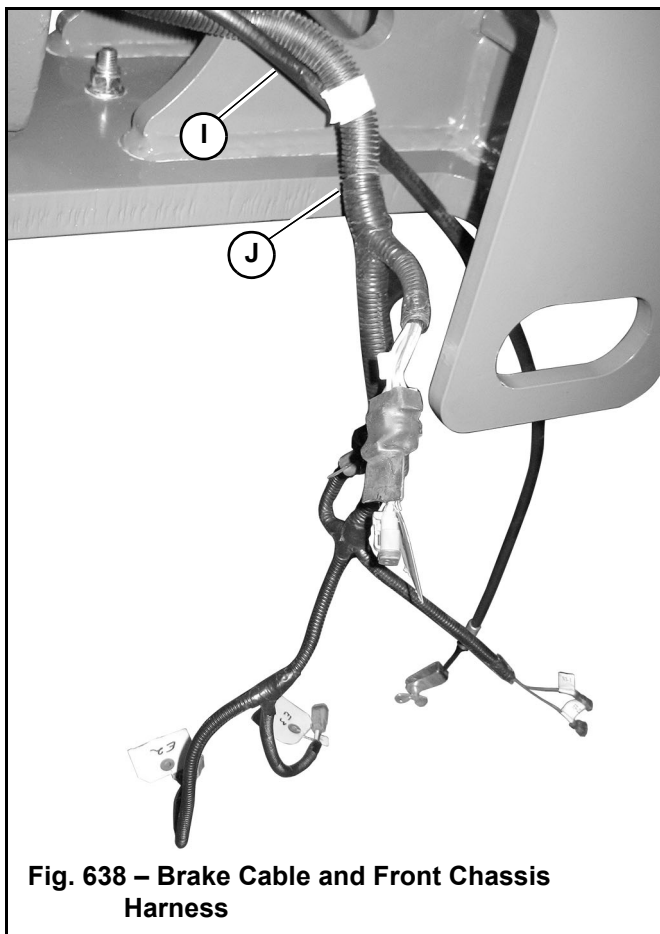

**Fig. 638 – Brake Cable and Front Chassis Harness**

29. On the left side of the machine, connect the front and rear chassis harness connectors (K, Fig. 639) [60] together.

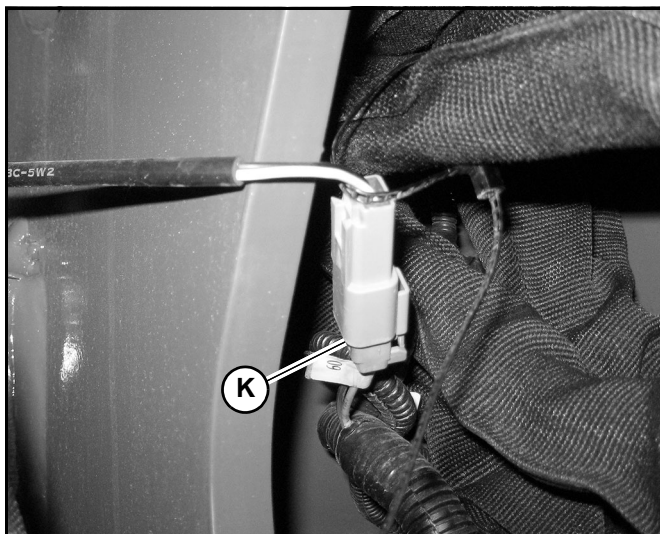
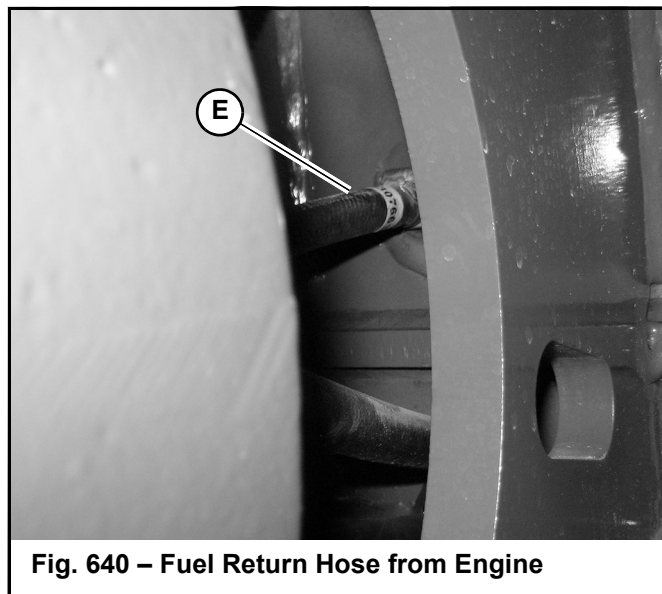

**Fig. 639 – Front Chassis Harness Connectors**

30. Connect all the remaining front chassis harness connectors.

**IMPORTANT:** Make the connections in the same locations as noted in step 22 on page 463.

31. Route fuel return hose (E, Fig. 640) from the rear chassis through the articulation joint.

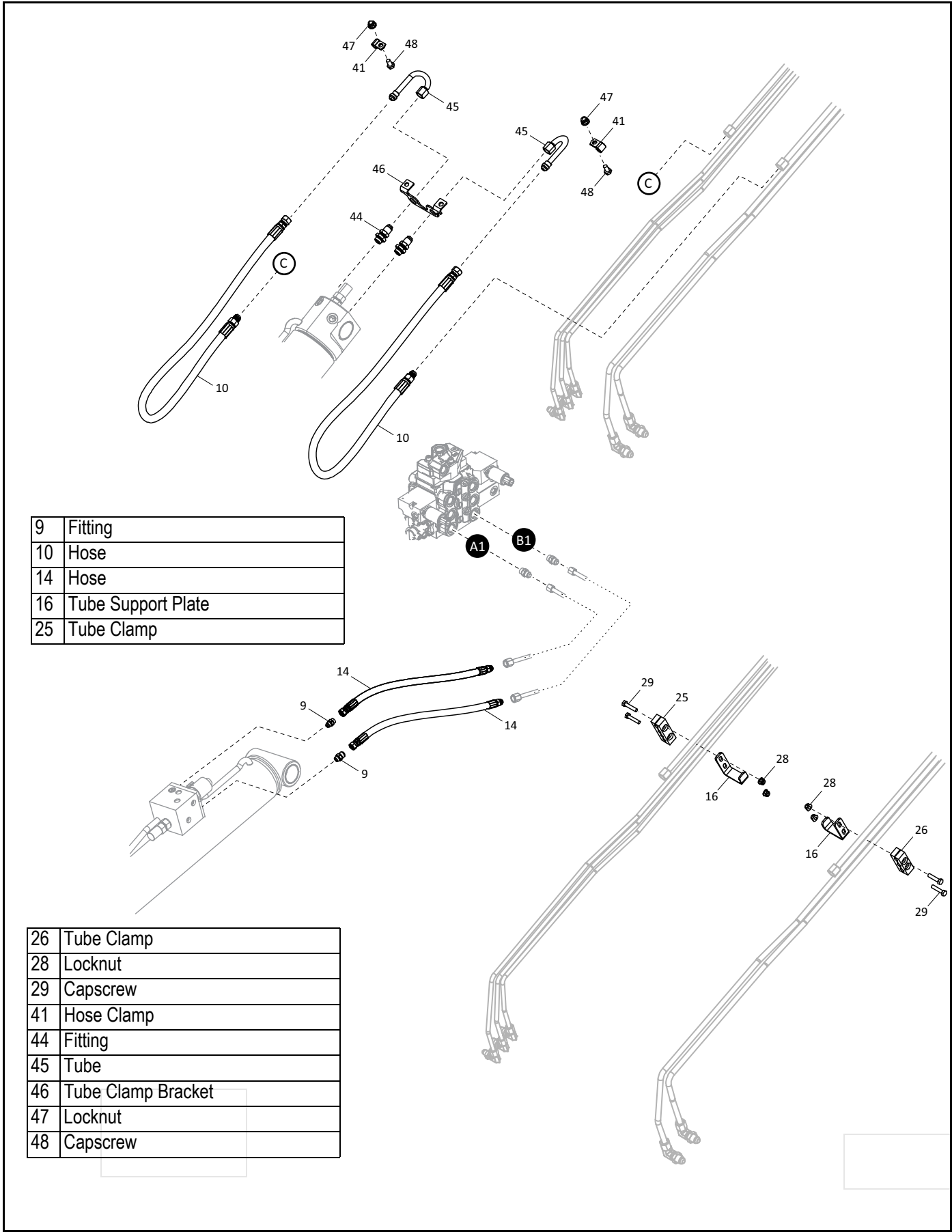

**Fig. 640 – Fuel Return Hose from Engine**

32. Continue routing the hose (E) to the fuel tank fitting in the front chassis.

33. Connect hose (E) to the fuel tank fitting. Tighten hose clamp securely.

## Load Arm Hydraulics (2 of 3)



9	Fitting
10	Hose
14	Hose
16	Tube Support Plate
25	Tube Clamp

26	Tube Clamp
28	Locknut
29	Capscrew
41	Hose Clamp
44	Fitting
45	Tube
46	Tube Clamp Bracket
47	Locknut
48	Capscrew

# Telescopic Load Arm

17. On new machines, install the P-clamps (G, Fig. 22) over the tilt cylinder hoses (S) inside the inner load arm, as shown.

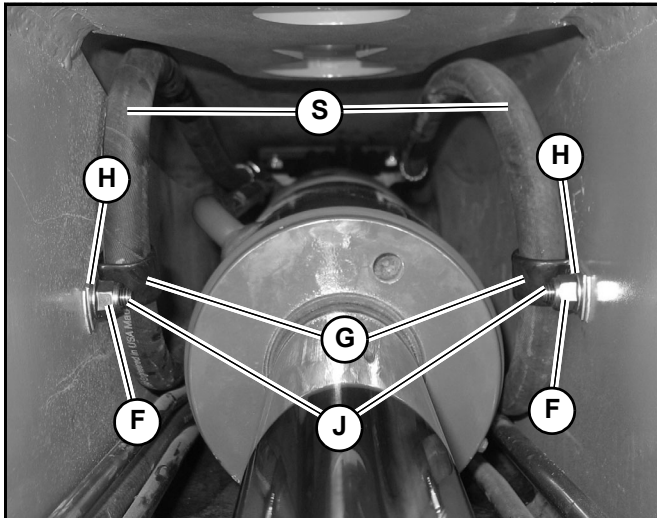

Fig. 22 – P-Clamp Installation

18. Fasten the P-clamps (G) using screws (J), flat washers (H) and locknuts (F). Tighten securely.
19. Rotate connecting link (E, Fig. 23) rearward into pivot link (X, Fig. 21).

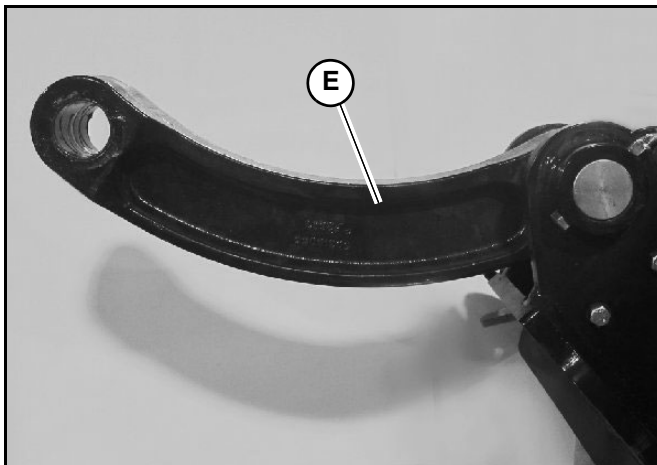

Fig. 23 – Connecting Link Position

20. Align bottom pin holes in connecting (E, Fig. 23) and pivot (X, Fig. 24) links and install the bottom pin (G) through both links.

**NOTE:** Install bottom pin (G) with hole for screw (F) on the right.

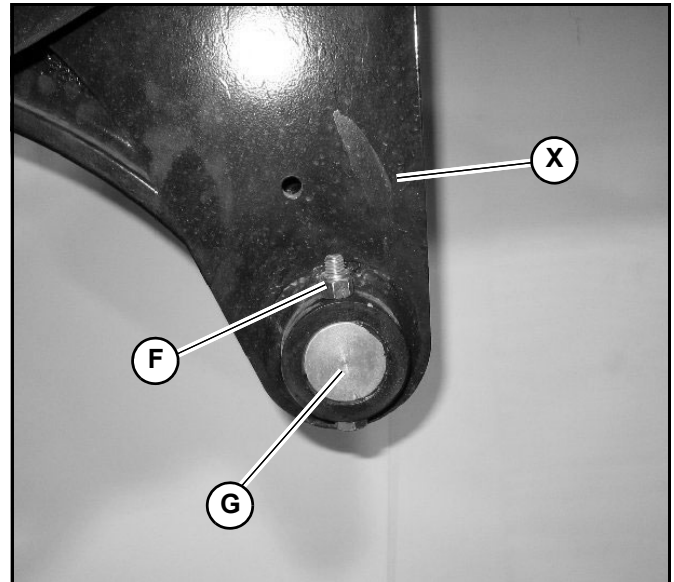

Fig. 24 – Connecting Link Bottom Pin

21. Retain bottom pin (G) using screw and nut (F). Tighten securely.
22. To prevent damage to the couplers and brackets during the following step, temporarily fasten hydraulic quick couplers/brackets (B and C, Fig. 25) to the load arm using screws and nuts (A).

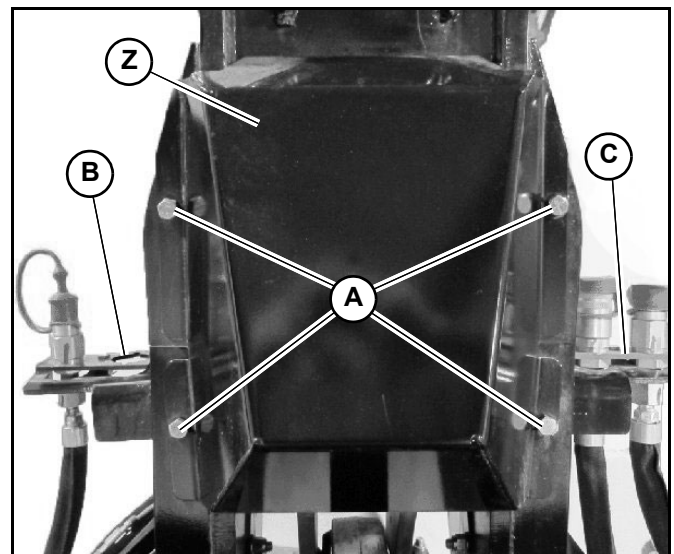
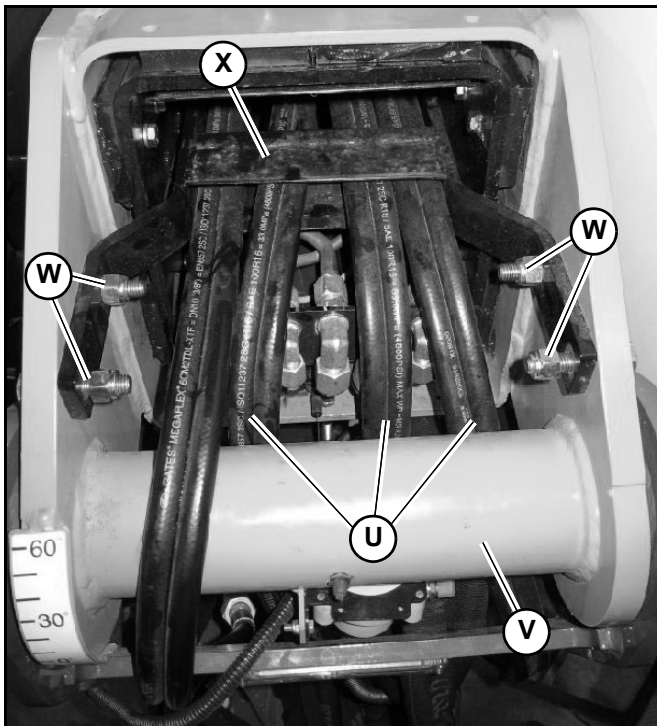

Fig. 25 – Front Cover

# Telescopic Load Arm



**Fig. 49 – Load Arm Hoses / Hose Support**

13. Secure hose support (X) using screws and nuts (W). Tighten securely.
14. Ensure hoses are routed and curve naturally along a vertical plane inside the load arm as shown in Fig. 50.

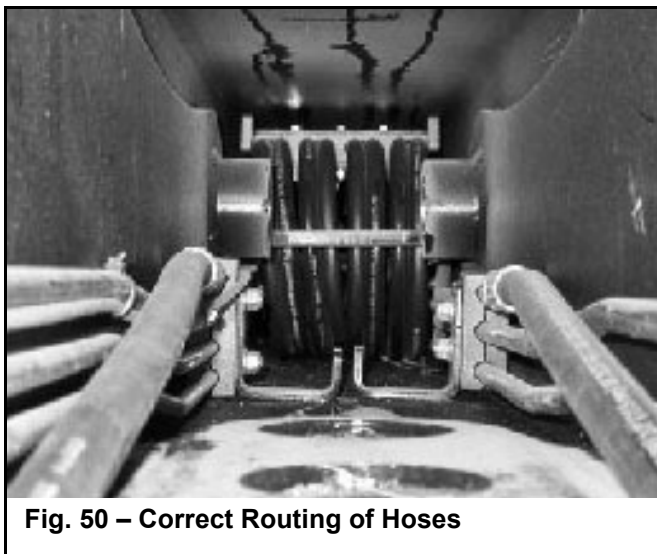

**Fig. 50 – Correct Routing of Hoses**

15. Connect tilt sensor interconnect wire connectors (O, Fig. 51) [60-1 and 60-2] together.

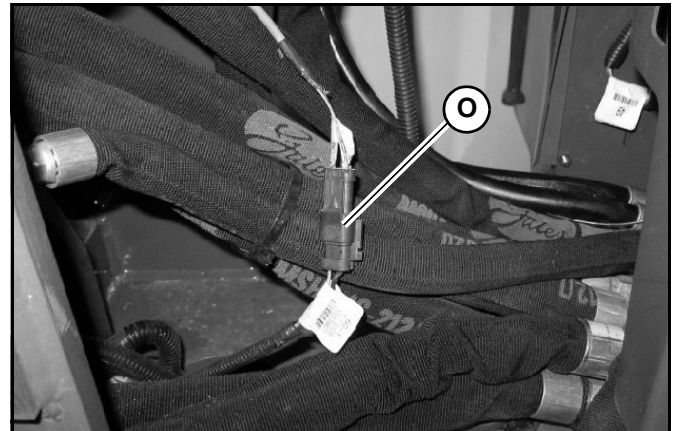

**Fig. 51 – Tilt Sensor Interconnect Connector**

16. Remove caps/plugs and connect attachment hitch hydraulic hoses (S and T, Fig. 52) to the tube connections at the front right corner of the ROPS/FOPS. Tighten securely.

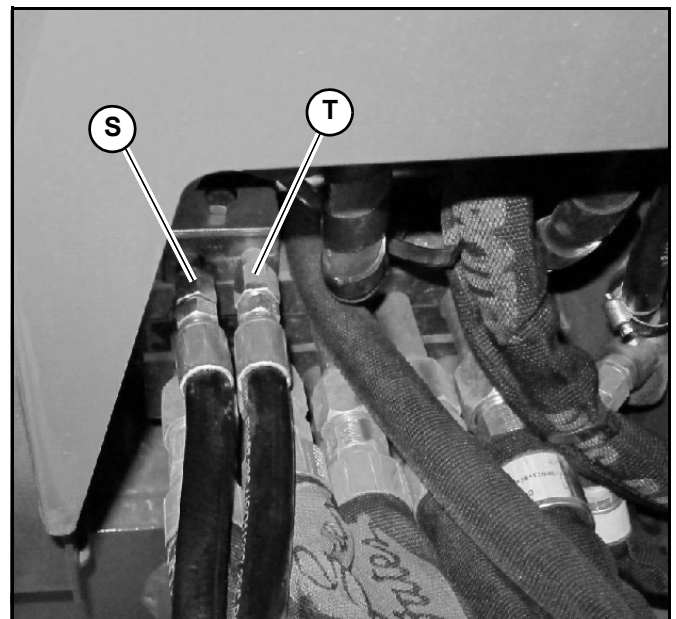

**Fig. 52 – Attachment Hitch Hydraulic Hoses**

# Telescopic Load Arm

3. Shut down the machine according to “Mandatory Safety Shutdown Procedure” on page 22.
4. Remove screws and nuts (C, Fig. 77) at the top or the sides of the cover (D) at the rear of the load arm. Remove cover (D).

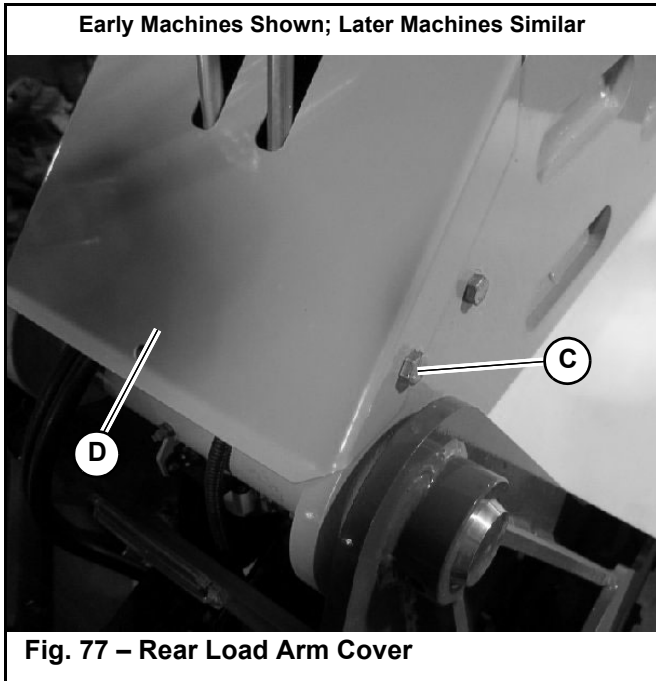

5. Disconnect hydraulic fittings/tubes (I and L, Fig. 78) from the load arm extend cylinder. Cap/plug openings to prevent contamination.

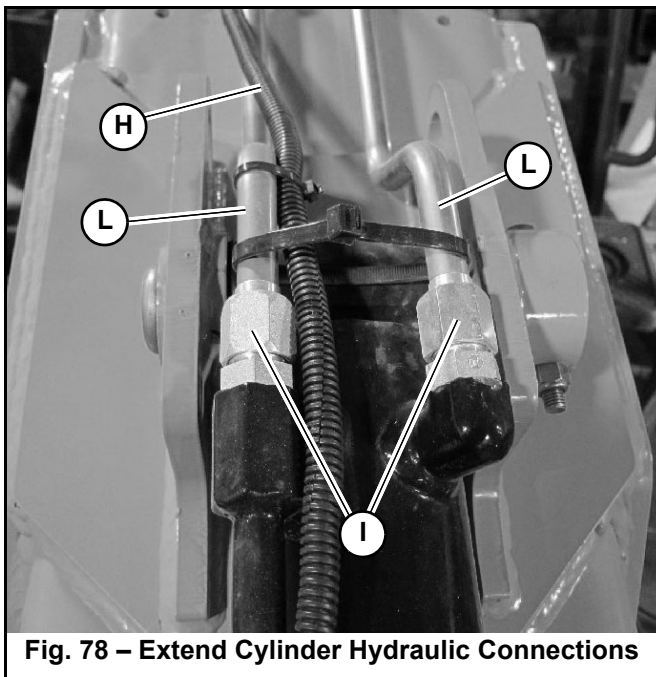

6. Cut wire ties as needed and move the light harness (H) to the side.
7. Disconnect hoses (J, Fig. 79) at the bottom of hydraulic tubes (L). Cap/plug opening to prevent contamination.

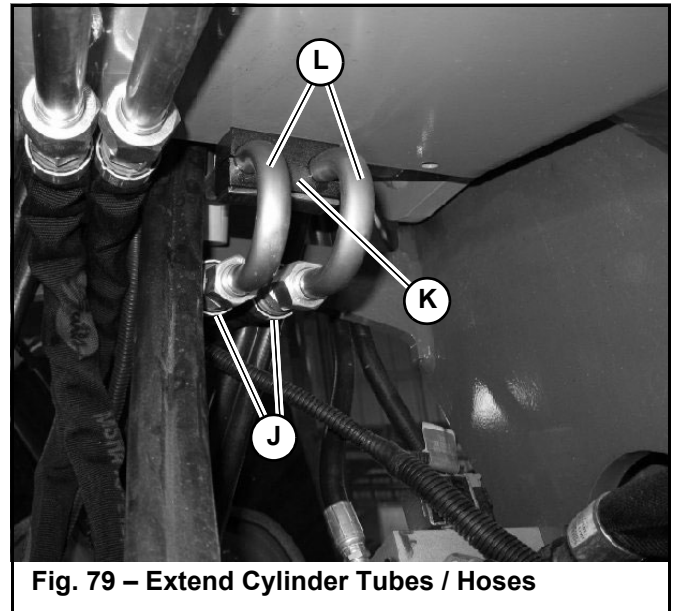

8. Remove clamp (K) and remove hydraulic tubes (L).
9. Label and disconnect auxiliary hydraulics hoses (M and N, Fig. 80) from the back of the auxiliary drain valve. Cap/plug openings to prevent contamination.

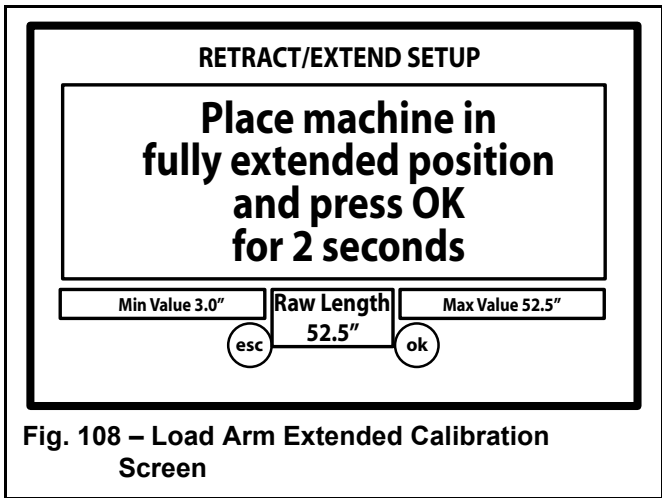

- 9. Press the ok button (G, Fig. 105) on the multi-purpose display for 2 seconds.

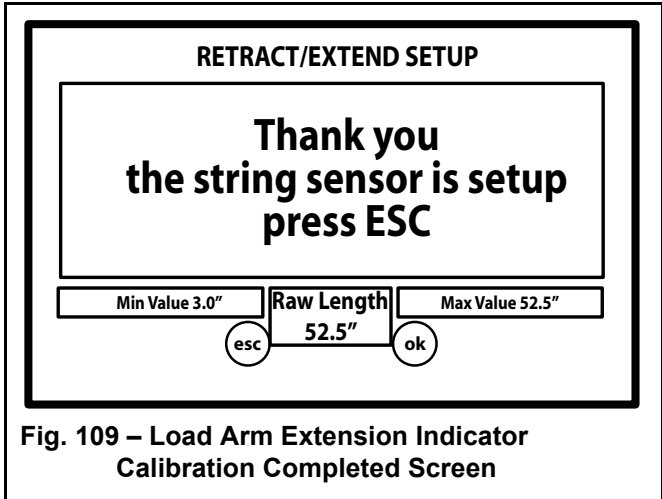

- 10. Press the esc button (F, Fig. 105) on the multi-purpose display.

6. Secure the V-belt guard and belt guard bracket (I, Fig. 110) to the chassis using screws and washers (F). Tighten securely.
7. Secure access panel (G) using screws (H). Tighten securely.

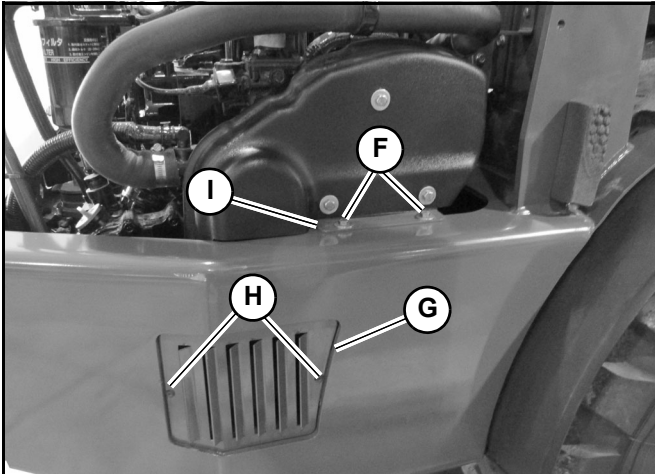

**Fig. 110 – V-Belt Guard Bracket and Right Access Panel**

8. Turn the battery disconnect switch to the ON position.



## CAUTION

**The air conditioning system must be repaired, serviced, and filled with refrigerant only by trained staff and in a workshop authorized in air conditioning maintenance.**

9. Charge air conditioning system according to “Air Conditioning System Charging” on page 530.
10. Close the engine cover.
11. Start the machine and test air conditioning function. Repair/correct as necessary.

39. Remove screw and nut (D, Fig. 136), washer (E) and isolator (F) from the left front engine mount. Discard screw (D).

**NOTE:** Replace screw (D) during reinstallation. Refer to the parts manual for ordering information.

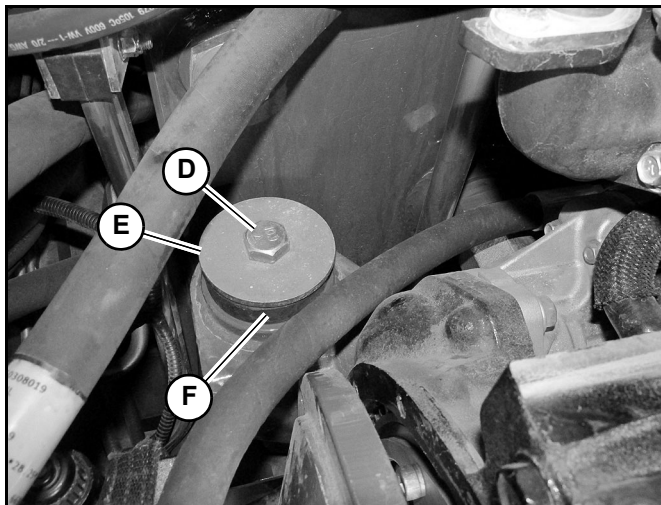

**Fig. 136 – Left Front Engine Mount**

40. At all four engine mounts:

- a. Lift the engine slightly and remove screws and washers (G, Fig. 137) securing engine mount (H) to the engine. Discard screws (G).

**NOTE:** Replace screws (G) during reinstallation. Refer to the parts manual for ordering information.

## CAUTION

Use care when removing the engine to not damage the DPF. The DPF is fragile and can be damaged by rough handling.

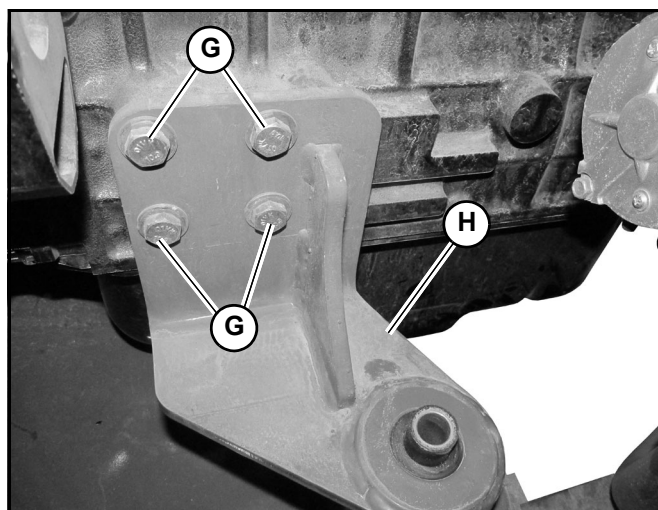

**Fig. 137 – Engine Mount Screws**

41. Remove engine mounts (H).
42. Slowly and carefully lift the engine far enough to label and disconnect electrical connections (T, Fig. 138) [10 and 11] from the back of the alternator.

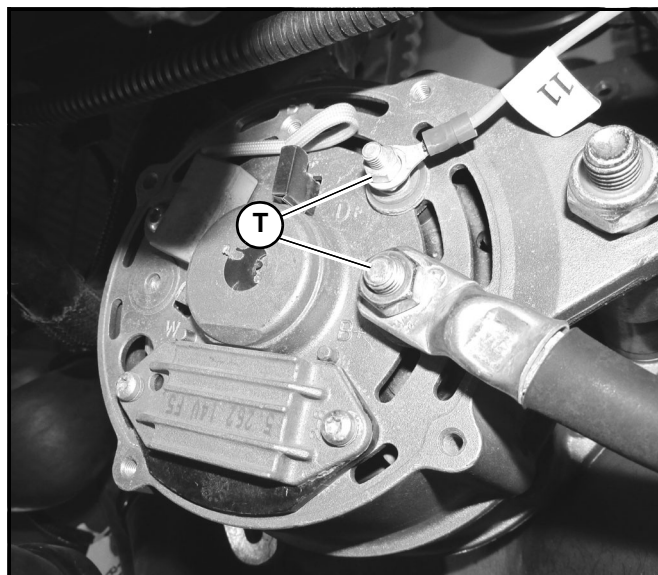

**Fig. 138 – Alternator Electrical Connections**

# 700 Series / MLA-7 / MLA-T Engine

## 700 Series / MLA-7 / MLA-T Engine Removal

**NOTE:** Label all hoses, tubes, and electrical connections. Note their locations before disconnecting to ensure correct re-installation.

**NOTE:** As parts are removed during engine removal, store them in an orderly fashion in a safe, clean place.

**NOTE:** Cap and plug all exposed coolant/hydraulic system openings to prevent contamination.

**IMPORTANT:** Park the machine where the engine can be removed with a suitable lifting device.

### **WARNING**

Use proper lifting equipment. Lifting the engine without proper equipment could result in serious personal injury or equipment damage. Keep clear of suspended loads.

**NOTE:** Some machines may vary slightly from what is shown in the photographs in this manual. Procedures will be similar.

### **WARNING**

Diesel fuel is flammable. Keep the machine away from open flames. Do not smoke when refueling or when working on the engine. Stop the engine before fueling.

Wear eye protection. The fuel system is under pressure and fuel could spray out when removing fuel system components.

Collect draining fuel into an approved container and wipe up spills immediately. NEVER use a shop rag to catch draining/leaking fuel. Vapors from the rag are flammable and explosive.

Failure to follow these instructions can cause fire and result in injury or death.

1. Complete the “Mandatory Safety Shutdown Procedure” on page 22.
2. Wait until the engine has cooled. See “Maintenance and Service Safety Practices” on page 31.
3. Turn the battery disconnect switch to the OFF position.
4. Disconnect the battery cables and remove the battery from the machine.
5. If the machine is equipped with air conditioning, remove the air conditioning compressor belt according to “Air Conditioning Compressor Belt” on page 195.
6. Remove the engine cover according to “Engine Cover Removal/Replacement” on page 431.
7. Remove hardware (A, Fig. 168) securing lower engine access panels (B) and remove the panels.

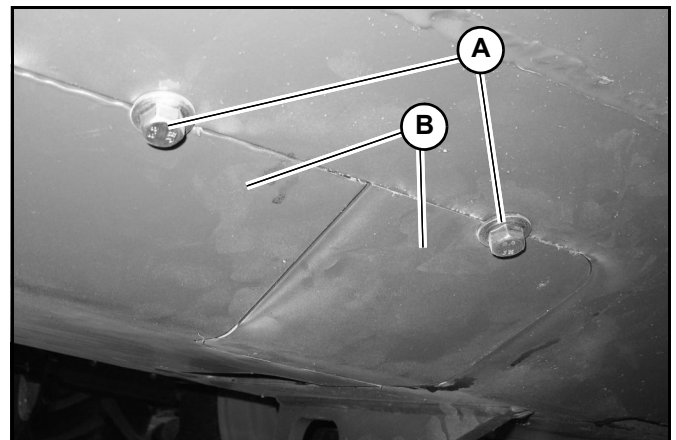

Fig. 168 – Lower Engine Access Panels

### **WARNING**

Allow engine and cooling system components to cool before continuing the procedure.

8. Drain the cooling system according to “Draining/Refilling Cooling System” on page 165.

## 700 Series / MLA-7 / MLA-T Engine Installation

**NOTE:** Some machines may vary slightly from what is shown in the photographs in this manual. Procedures will similar.

**IMPORTANT:** Always verify electrical connections are sound and strain relieved when static and to accommodate moving components and machine operation. Route, tie, and clamp all wires and connections to avoid pinching, chafing, and damage consistent with factory design and practice.

1. Locate threaded lifting holes (P, Fig. 192) on both side of the engine block.

**NOTE:** Holes (P) are threaded to accept M12-1.75 bolts.

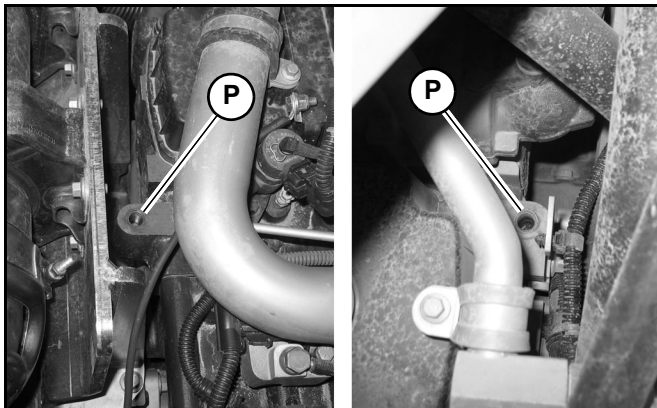

Fig. 200 – Engine Lift Points

2. Attach a spreader bar (L, Fig. 193), with bolts (N) as shown in the figure. Thread bolts until they bottom into holes (P, Fig. 192).

**NOTE:** Spreader bar dimension (K) is 540 mm (21-1/4 in.); M12-1.75 bolt length (N) is 197 mm (7-3/4 in.)

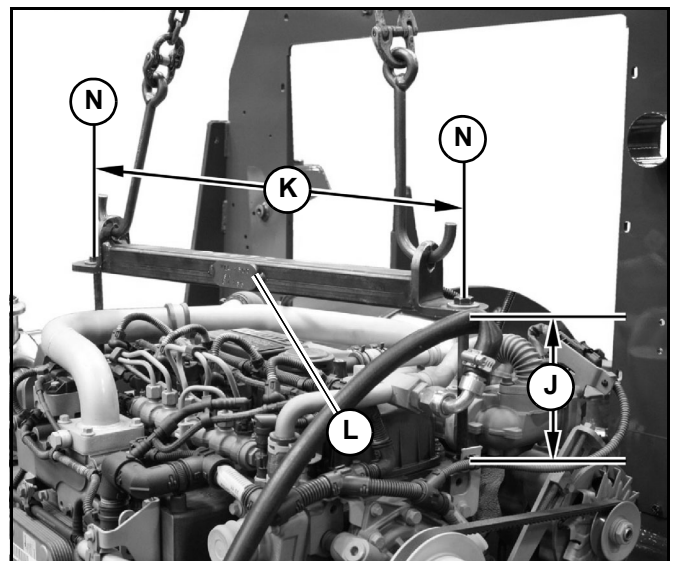

Fig. 201 – Engine Lift Spreader Bar

3. Support the engine with an appropriate lifting device

**NOTE:** Make sure all lifting gear is sufficient to support more than the weight of the engine; approximately 270 kg (595 lbs.).



### WARNING

Do NOT use any lifting attachments (slings, chains) that are damaged or of inadequate rated capacity.



### WARNING

Keep hands and feet clear when positioning the engine in the machine. Severe pinching/crushing injury can occur.

4. Lift the engine and position it inside the engine compartment.



### CAUTION

Use care when positioning the engine to not damage the DOC. The DOC is fragile and can be damaged by rough handling.

# Engine Cooling System

## Engine Cooling System General Information

This section includes component identification and radiator removal/installation information for the engine cooling system.

The coolant system in the machine consists of a mid-mounted radiator set high on the machine, inside and toward the front of the engine compartment. The radiator is split to provide both engine cooling and hydraulic oil cooling.

### Cooling Fan Operation

A hydraulically-powered fan provides air flow through the radiator. Fan rotation can be momentarily reversed to clear particulate matter from the radiator.

**NOTE:** An electrical failure of the fan cooling system causes the fan to operate at maximum speed.

At startup with a cold engine, the fan does not activate until:

- Engine coolant temperature exceeds 85°C (185°F) for more than 20 seconds.
- OR-
- Hydraulic oil temperature exceeds 66°C (150°F).

**NOTE:** If air conditioning is turned on, the cooling fan runs at a minimum of 25% (725 rpm).

When the machine is at operating temperature, fan operation is based upon a combination of engine coolant and hydraulic oil temperature:

**Table 1: Cooling Fan Operation**

Engine Coolant Temp (°C/°F)	Hydraulic Oil Temp (°C/°F)	Fan Speed	Fan RPM <sup>a</sup>
68/155	60/140	0%	0
74/165	66/150	25%	725
79/175	71/160	50%	1450
85/185	77/170	75%	2175
91/195	82/180	100%	2900

a. Fan rpm values based on engine speed of 2300 rpm.

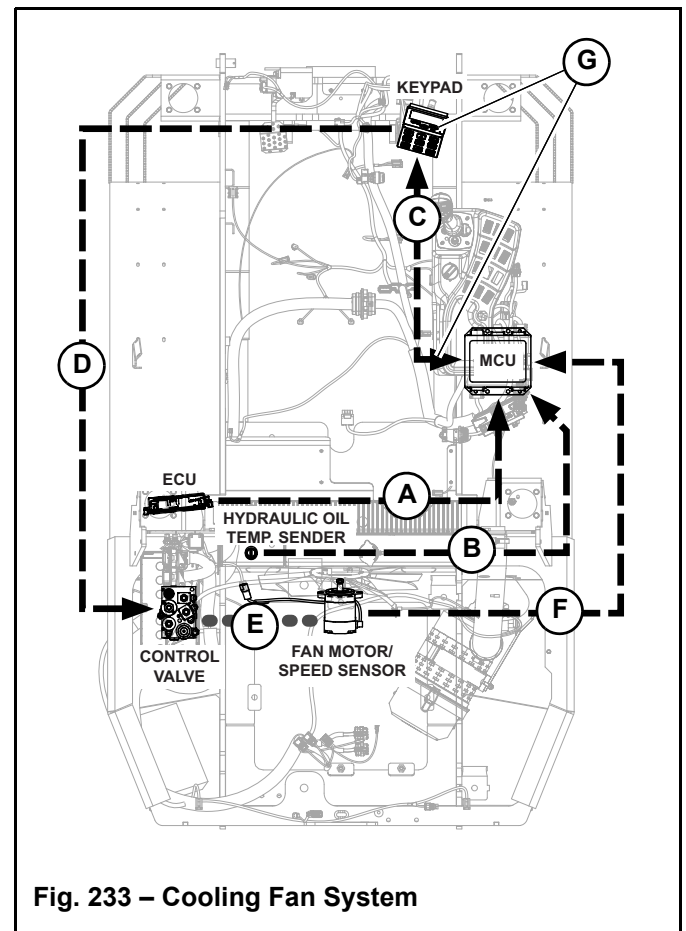
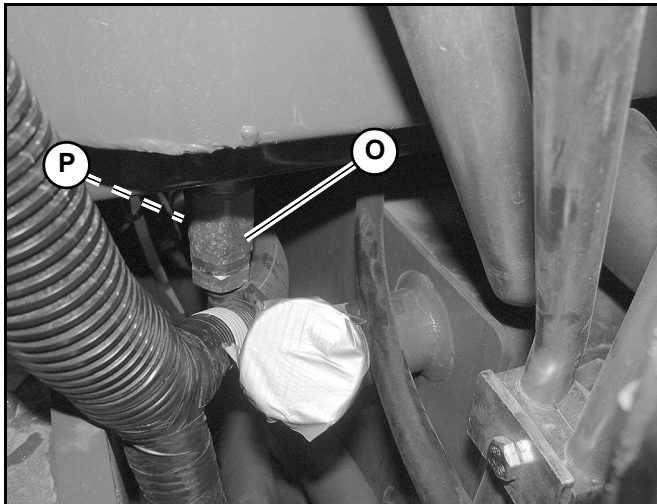

**Fig. 233 – Cooling Fan System**

A. Engine coolant temperature data is sent from the engine ECU to the MCU via CAN.

# Engine Cooling System

14. Remove caps and plugs and loosely install tee fitting (O, Fig. 253) in the bottom of the radiator.



**Fig. 253 – Tee Fitting**

15. Remove caps and plugs and connect hydraulic hose (P) to the tee fitting (O) and tighten securely.
16. Tighten tee fitting (O) securely.
17. Connect electrical connector (Q, Fig. 254) to the hydraulic oil temperature sensor.

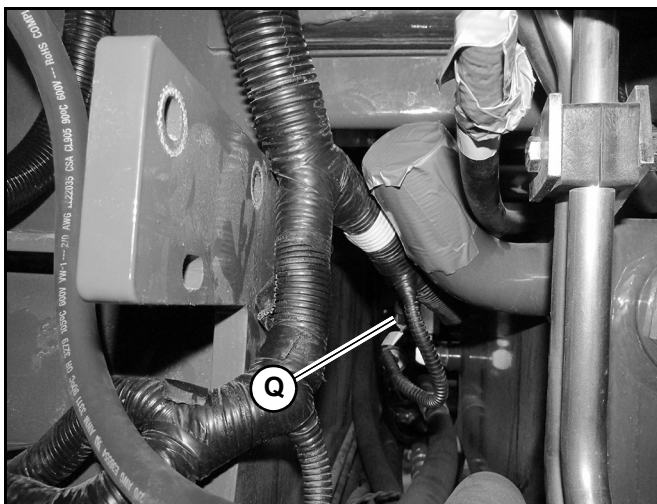

**Fig. 254 – Temperature Sensor**

18. Remove caps and plugs and connect the hydraulic oil fill and overflow hose to hydraulic oil filler neck (S, Fig. 255). Tighten hose clamps (R) securely.

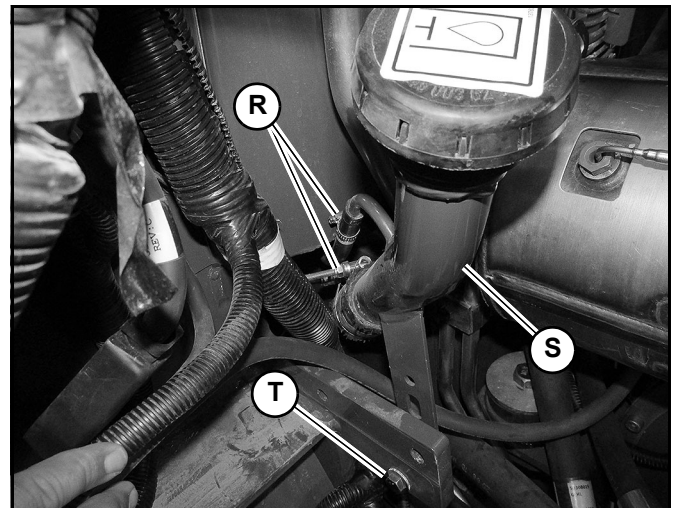

**Fig. 255 – Hydraulic Oil Filler Neck**

19. Securing the hydraulic oil filler neck using screw and nut (T).
20. Remove caps and plugs and connect tube (U, Fig. 256) to the radiator. Tighten securely.

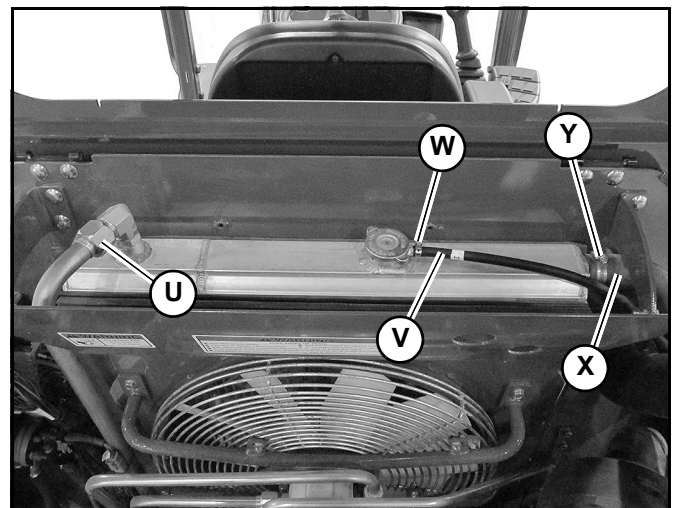
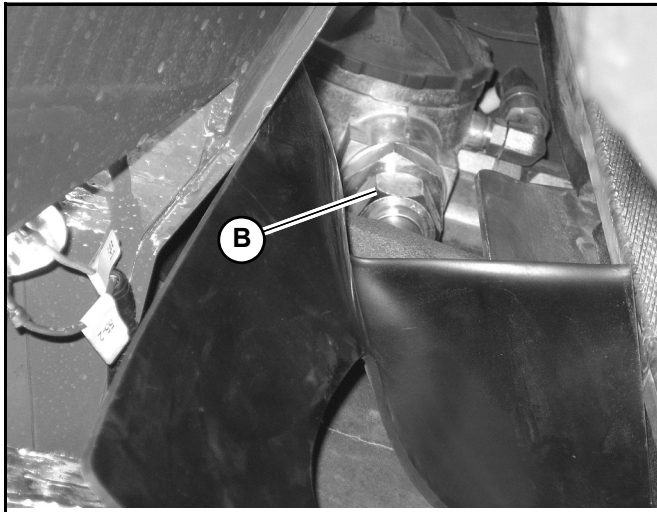

**Fig. 256 – Radiator**

21. Connect coolant overflow hose (V) to the radiator filler neck. Tighten hose clamp (W) securely.
22. Connect upper radiator hose (X) to the radiator and tighten hose clamp (Y) securely.

# Engine Cooling System

26. Remove caps and plugs and connect hydraulic tube (B, Fig. 283) to the filter head. Tighten securely.



**Fig. 283 – Hydraulic Tube Filter Connection**

27. Replace right side panel (B, Fig. 284) and secure it with wing nuts (A).

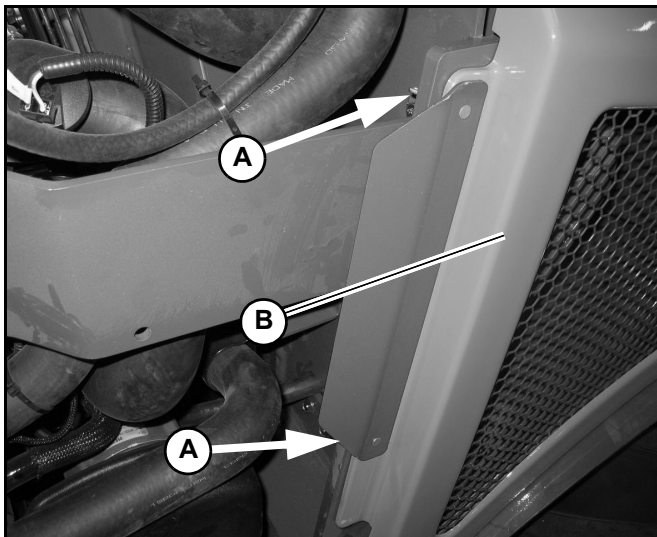

**Fig. 284 – Side Panel Installation**

28. Secure battery tray (F, Fig. 285) to the chassis using two screws and nuts (C). Tighten securely.

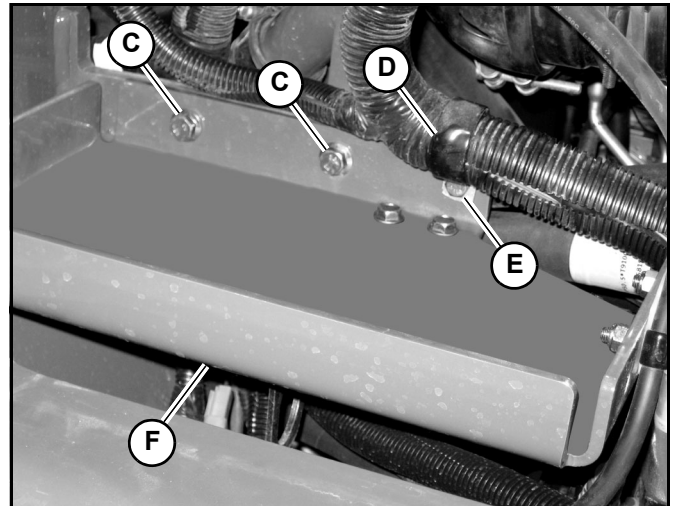

**Fig. 285 – Battery Tray Installation**

29. Secure harness with clamp (D) to the battery tray using screw and locknut (E).

30. Secure windshield washer reservoir filler neck (G, Fig. 286) to battery tray (H) using screws and locknuts (I).

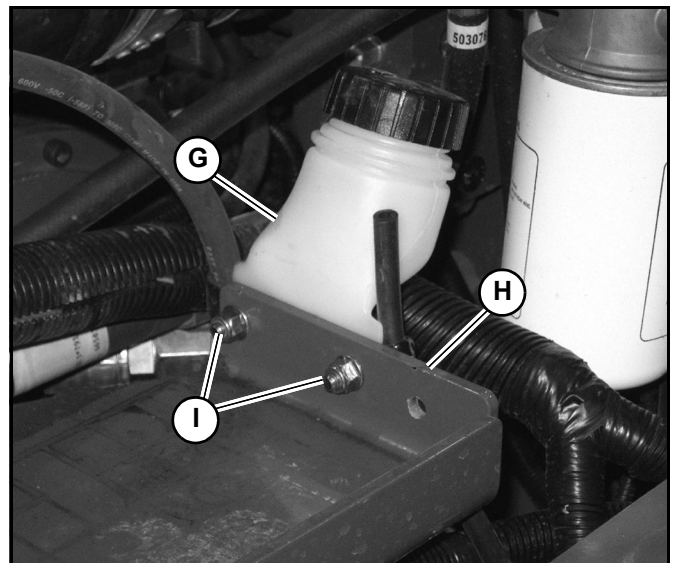

**Fig. 286 – Windshield Washer Reservoir Filler**

31. Install the battery and connect the battery cables.
32. Refill the hydraulic oil reservoir with the proper amount and grade hydraulic oil. See “Changing Hydraulic Oil” on page 174.

**Table 8: Yanmar Engine Diagnostic Trouble Codes (DTC)**

DTC			Error Item	
SPN	FMI	P-Code	Part	State
651	6	P0271	Injector 1 (Cylinder Number 4)	Injector 1 coil short-circuit
651	11	P0272	Injector 1 (Cylinder Number 4)	Injector 1 unclassified
652	3	P1262	Injector 1 (Cylinder Number 3)	Injector 1 short-circuit
652		P1268	Injector 4 (Cylinder Number 3)	Injector 4 short-circuit
652	5	P0203	Injector 1 (Cylinder Number 3))	Injector 1 open circuit (inherent location of the Injector)
652		P0203	Injector 4 (Cylinder Number 3)	Injector 4 open circuit (inherent location of the injector)
652	6	P0268	Injector 1 (Cylinder Number 3)	Injector 1 coil short-circuit
652		P0268	Injector 4 (Cylinder Number 3)	Injector 4 coil short-circuit
652	11	P1263	Injector 1 (Cylinder Number 3)	Injector 1 unclassified
652		P1269	Injector 4 (Cylinder Number 3)	Injector 4 unclassified
653	3	P1265	Injector 2 (Cylinder Number 2)	Injector 2 short-circuit
653	5	P0202	Injector 2 (Cylinder Number 2)	Injector 2 open circuit (inherent location of the injector)
653	6	P0265	Injector 2 (Cylinder Number 2)	Injector 2 coil short-circuit
653	11	P1266	Injector 2 (Cylinder Number 2)	Injector 2 unclassified
654	3	P1262	Injector 3 (Cylinder Number 1)	Injector 3 short-circuit
654	5	P0201	Injector 3 (Cylinder Number 1)	Injector 3 open circuit (inherent location of the injector)
654	6	P0262	Injector 3 (Cylinder Number 1)	Injector 3 coil short-circuit
654	11	P1263	Injector 3 (Cylinder Number 1)	Injector 3 unclassified
1078	4	P0340	Fuel Injection Pump Speed Sensor	Shorted to low source
1079	2	P1644	Sensor 5V	Intermittent fault
1079	3	P0643	Sensor 5V	Shorted to high source
1079	4	P0642	Sensor 5V	Shorted to low source
1136	0	P0634	ECU Internal Temperature	Too high
1136	2	P1664	ECU Internal Temperature Sensor	Intermittent fault
1136	3	P0669	ECU Internal Temperature Sensor	Shorted to high source
1136	4	P0668	ECU Internal Temperature Sensor	Shorted to low source
1202	2	U423	Immobilizer	System fault
1209	3	P0473	EGR High Pressure Side Sensor	EGR low pressure side sensor fault (high voltage)
1209	4	P0472	EGR High Pressure Side Sensor	EGR low pressure side sensor fault (low voltage)
1209	13	P0471	EGR High Pressure Side Sensor	Abnormal learning value
1209	10	P1679	EGR High Pres. Sensor Malfunction	After-treatment error
1210	3	P1203	Engine Fuel Rack Position Sensor	Shorted to high source
1210	4	P1202	Engine Fuel Rack Position Sensor	Shorted to low source
1485	2	P068A	Main Relay	Power off without main relay self-holding/main relay early opening
1485	4	P0686	ECU Main Relay	Shorted to low source
1485	7	P068B	Main Relay	Main relay contact stuck
2791	0	P0404	EGR Valve	EGR over-voltage malfunction
2791	1	P1404	EGR Valve	EGR low voltage malfunction

**Table 9: Deutz Engine Diagnostic Trouble Codes (DTC)**

DTC		Trouble Code Type	Error Description
SPN	FMI		
677	4	Starter Relay Error	Starter Relay (high side power stage): The current drop measured by ECU is above the target range; starter relay low side short circuit to ground.  Starter Relay (high side power stage): The current drain measured by ECU is above the target range; starter relay high side, short circuit to ground
677	5	Starter Relay Error	Starter Relay (low side power stage): the current drop measured by ECU is above the target range; open circuit/disconnection LowSide-Output
677	12	Starter Relay Error	Starter Relay (low side power stage): the current drop measured by ECU is above the target range; starter relay powerstage over temperature
729	3	Short-Circuit Error	Intake Air Heater Device; short-circuit to battery
729	4	Short-Circuit Error	Air intake heater; Short circuit to ground error for powerstage on CJ945
729	5	Cold Start Error	Cold start aid relay open load
898	9	Timeout Error	Timeout error: limp mode activated
1079	13	(ECU) Error	Internal Hardware Monitoring: the ECU detects a deviation of the target range of the power supply voltage of sensor output 1
1080	13	(ECU) Error	Internal Hardware Monitoring: the ECU detects a deviation of the target range of the power supply voltage of sensor output 2
1109	2	Engine Shut-off Error	Operator ignores the engine shut off request within an allowed period.
1136	0	ECU Temperature Range Check Error	Physical range check high for ECU temperature
1176	0	Turbine Pressure Sensor Out-Of-Range Error	Pressure sensor upstream turbine, physical range check high
1176	3	Turbine Pressure Sensor Out-Of-Range Error	Pressure sensor upstream turbine, signal range check (SRC) high
1176	4	Turbine Pressure Sensor Out-Of-Range Error	Pressure sensor upstream turbine, signal range check (SRC) low
1231	14	CAN BusOff Error	CAN Bus 1: the ECU is not allowed to send messages, because the status "BusOff" is detected
1235	14	CAN Bus Error	CAN-Bus 2 = engine bus BusOff-Status
1237	2	Override Switch Error	Override Switch: the ECU receives a permanent signal, plausibility error

**Table 9: Deutz Engine Diagnostic Trouble Codes (DTC)**

DTC		Trouble Code Type	Error Description
SPN	FMI		
524063	5	Electrical Error	Urea backflow line heater: broken wiring detected Threshold 1 < SCRHtr_rUHtrMeasRatio_mp < Threshold 2 SCR main relay not connected; SCR heater pressure line; open load; Relay Urea suction line: broken wiring detected (open load) -- SCR suction line (K28) SCR heater supply module; open load SCR heater tank; open load
524063	12	Timeout Error	DEF tank, time for defrosting too long
524065	0	Over-Pressure Error	Pressure sensor upstream SCR-CAT, pressure above upper physical threshold
524065	1	Under-Pressure Error	Pressure sensor upstream SCR-CAT, pressure below lower physical threshold
524065	2	Plausibility Error	Pressure sensor upstream SCR-CAT, plausibility error
524065	3	Electrical Error	Pressure sensor upstream SCR-CAT; short circuit battery or open load
524065	4	Short-Circuit Error	Pressure sensor upstream SCR-CAT; short circuit ground
524067	0	Over-Temperature Error	DEF supply module, heater temperature above upper physical threshold
524067	1	Under-Temperature Error	DEF supply module, heater temperature below lower physical threshold
524067	2	Plausibility Error	Supply module heater temperature, plausibility error
524074	9	Electrical Error	NOx sensor downstream SCR-CAT, sensor internally open load
524075	11	Short-Circuit Error	NOx sensor downstream SCR-CAT, sensor internally short circuit
524076	9	Electrical Error	NOx sensor upstream SCR-CAT, sensor internal open line
524077	11	Short-Circuit Error	NOx sensor upstream SCR-CAT, sensor internal short-circuit
524078	9	Plausibility Error	NOx sensor downstream SCR-CAT, lambda value above upper physical threshold
524079	9	Plausibility Error	NOx sensor downstream SCR-CAT, lambda value below lower physical threshold
524080	9	Plausibility Error	NOx sensor upstream SCR-CAT, lambda value above upper physical threshold

## Dimensions

### Non-Telescopic Machines

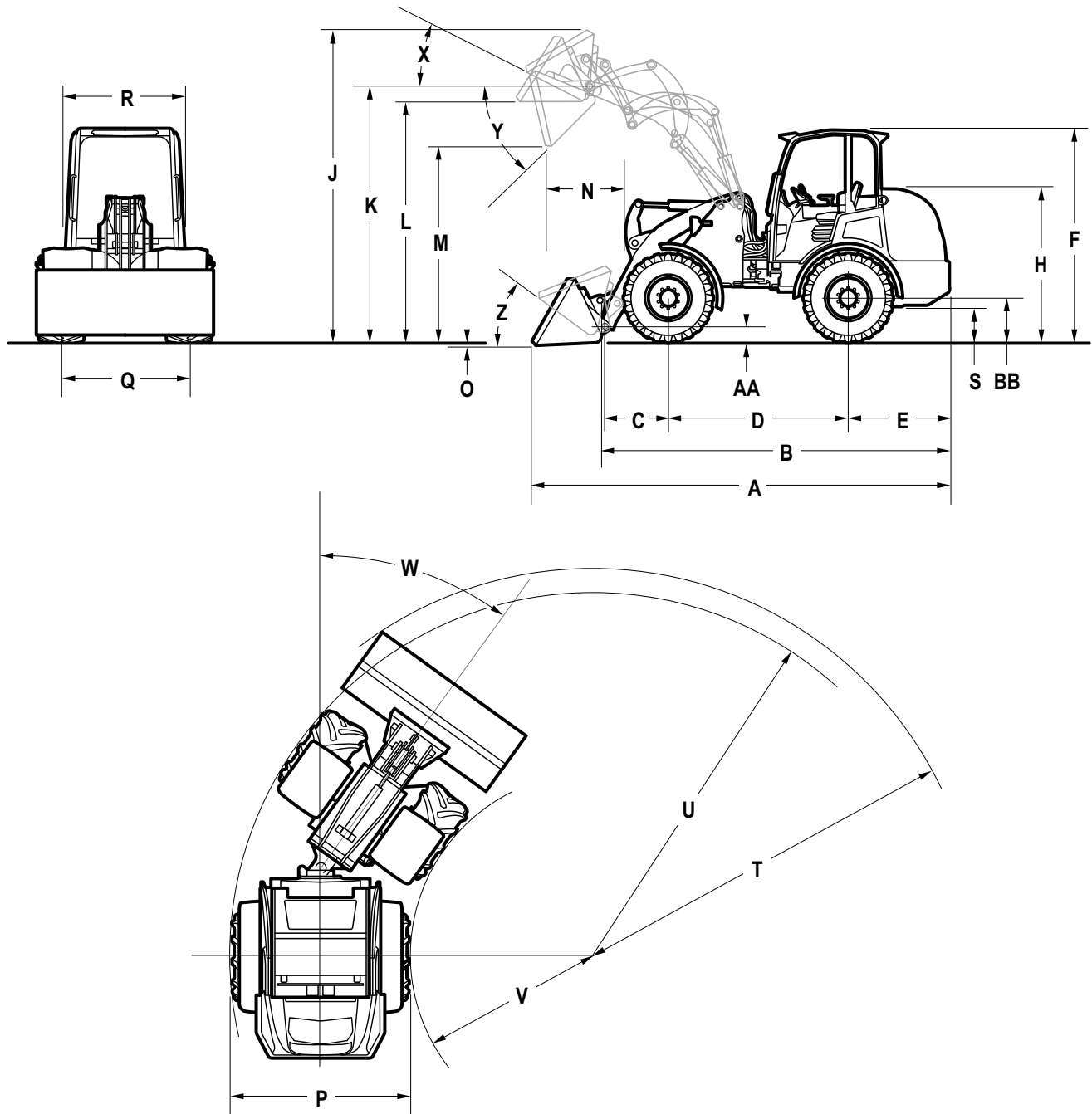

**Table 13: Dimensions (Non-Telescopic Machines)**

		<b>600 Series / MLA-6</b>	<b>700 Series / MLA-7</b>
A	Length with Bucket on Ground	5077 mm (199.9 in.)	5220 mm (205.5 in.)
B	Shipping Length	4260 mm (167.7 in.)	4443 mm (174.9 in.)
C	Front Wheel Center to Attachment Bracket	833 mm (32.8 in.)	931 mm (36.7 in.)
D	Wheelbase	2007 mm (79 in.)	2063 mm (81.2 in.)

# Index

## Numerics

14-Pin Connector .....	124
Fuses, Diodes, Relays .....	192
3-Speed Option .....	73, 97

## A

After Operation .....	135
Air Conditioning	
Charging .....	530
Compressor Belt .....	195
Compressor Installation	
700 Series / MLA-7 / MLA-T .....	532
Compressor Removal	
700 Series / MLA-7 / MLA-T .....	531
Refrigerant Recovery .....	530
Armrest .....	88
Articulation Joint	
Non-Telescopic	
Assembly .....	469
Disassembly .....	460
Service .....	433
Telescopic	
Assembly .....	444
Disassembly .....	434
Attachment Hitch .....	75
Attachment Mounting .....	75
Attachment Tilt Operation .....	103
Attachments	
Connecting/Disconnecting .....	114
4-Point System Hitch .....	116
Euro-Style System Hitch .....	116
Power-A-Tach® System Hitch .....	114
Electrical Power Connections .....	81
Hydraulic Powered .....	120
Audible Alerts .....	62
Auxiliary Hydraulics .....	75
2nd Circuit .....	76, 123
Control .....	76
High-Flow .....	77
High-Flow Operation .....	123
Operation .....	122
Pressure Relief .....	75
Standard-Flow .....	122
Auxiliary Hydraulics Control Switch .....	69
Axle Maintenance .....	178

## B

Backup Alarm .....	99
Battery .....	183
Disconnect Switch .....	82
Jump-starting .....	184
Beacon .....	79
Before Operation .....	85
Pre-Start Checks .....	83
Belt Maintenance .....	167
Brake	
Bleeding .....	243
Brake/Inch Pedal .....	72
Buckets	
Working with .....	125
Digging Tips .....	125
Safety Instructions .....	125
Standard Buckets .....	126
Backfilling .....	128
Scooping .....	126

## C

Cab .....	85
Door .....	85
Door Prop .....	86
Entry/Exit .....	85
Windows .....	86
Cab Heat/Air Conditioning .....	78
Maintenance .....	194
Cab/Canopy	
Installation .....	425
Removal .....	419
CAN Functional Detail .....	320
CAN Resistor .....	187
CAN System .....	313
Configuration .....	317
CAN System Service/Configuration .....	317
Chassis .....	419
Chassis Grounds .....	187
Checks During Operation .....	84
Component Identification .....	14
Component Serial Numbers .....	13
Computer Connection .....	317
Constant Speed .....	73, 98
Contents and Use of this Manual .....	11
Control Keypad .....	60

CLICK HERE TO **DOWNLOAD** THE COMPLETE MANUAL

- Thank you very much for reading the preview of the manual.
- You can download the complete manual from: [www.heydownloads.com](http://www.heydownloads.com) by clicking the link below



- Please note: If there is no response to CLICKING the link, please download this PDF first and then click on it.

CLICK HERE TO **DOWNLOAD** THE COMPLETE MANUAL