

GEHL®

Form No.
918197
English

Revision A
08/06

383z

Compact Excavator



Service Manual

CLICK HERE TO **DOWNLOAD** THE COMPLETE MANUAL

- Thank you very much for reading the preview of the manual.
- You can download the complete manual from: www.heydownloads.com by clicking the link below



- Please note: If there is no response to CLICKING the link, please download this PDF first and then click on it.

CLICK HERE TO **DOWNLOAD** THE COMPLETE MANUAL

1.3 Designated uses and exemption from liability

- The machine is intended for:
 - Excavating earth, gravel, coarse gravel, ballast or rubble.
 - Working with the attachments mentioned.
- Every other use and attachment is not designated for this machine. Gehl will not be liable for damage resulting from any other use or attachment. The user alone will bear the risk.
- Follow the instructions in the Operator's Manual, and also accident prevention regulations, safety and occupational regulations, and machine and traffic regulations. Gehl is not liable for damage resulting from the failure to follow these regulations.
- You can damage the machine by modifying it with parts, equipment, attachments and optional equipment not authorized by Gehl. Gehl is not liable for damage resulting from unauthorized modifications.
- Gehl is not liable for personal injury and/or damage to property caused by failure to properly:
 - operate,
 - transport,
 - service and maintain,
 - and repair the machine.as instructed in this manual and the Operator's Manual.
- Read and understand the Operator's Manual before starting, servicing, or repairing the machine. Follow the safety instructions.
- The machine may not be used for transportation on public roads.
- In applications with lifting gear, only use the machine according to its designated use.

1.4 Abbreviations/symbols

Abbreviations/symbols

- This symbol stands for a list
 - Subdivision within lists or an activity. Follow the steps in the sequence presented.
 - ☞ *This symbol requires you to carry out the activity described.*
 - ➡ Description of the effects or results of an activity.
- n. s. = not shown
- "Option" = optional equipment (indicated whenever controls or other components of the machine are installed as an option)

A combination of digits, or a combination of digits and letters, e.g. 40/18 or 40/A, is used for identifying figure elements. For example:

- Figure no. 40/ element no. 18, or position **A** in figure no. 40.
- Figures carry no numbers if they are placed to the left of the text.

1.14 Tilting the cab

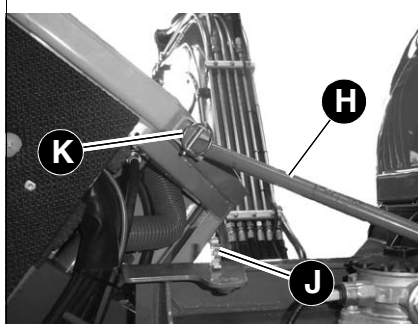
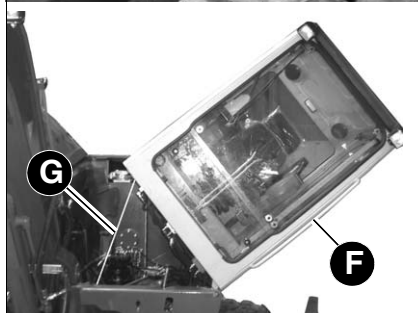
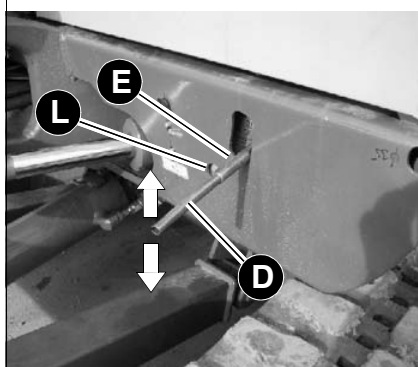
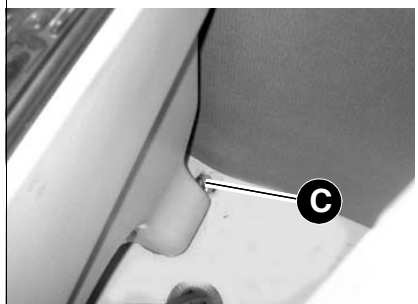
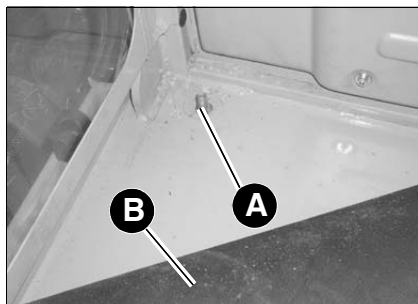

Fig. 10: Cab tilting



WARNING!

Careful when tilting the cab –

Risk of accidents.

- ☞ Always tighten cab lock-down nuts before driving or using the machine.
- ☞ Always close the cab door before tilting the cab.
- ☞ Stay clear from underneath the cab as it is tilted.
- ☞ Always secure the tilt rod in the support position when cab is tilted.

Tilting the cab up:

Tilt the cab up as follows:

- ☞ Follow the “Mandatory Safety Shutdown Procedure” in the Operator’s Manual.
- ☞ Raise the floor mat (B) on the right, front of the cab and remove cab lock-down nut (A). Remove cab lock-down nut (C) at the right rear of the cab.
- ☞ Securely close the cab door.
- ☞ Locate the jack handle tubes (D) from the tool kit in the engine compartment and insert into the jack (E) and jack to the limit. The cab will be raised as far as the jack will travel.
- ☞ Pull on handle (F) until the cab is completely tilted and supported by safety cable (G).
- ☞ Remove the tilt rod (H) from the storage bracket (J) and slide the tilt rod into the guide bracket (K) and secure with the split pin.

Tilting the cab down:

Tilt the cab down as follows:

- ☞ Remove the tilt rod (H) from the guide bracket (K) by removing the split pin and slide the tilt rod out of the guide bracket and secure with the split pin back in the storage bracket (J).
- ☞ Use handle (F) to slowly lower the cab back onto the jack.
- ☞ Remove jack handle tubes (D) from the jack and insert the opposite end of the jack handle tubes onto the release pin (L). Slowly turn the release pin counter-clockwise until the cab is lowered.
- ☞ Turn the release pin (L) clockwise.
- ☞ Reinstall the cab lock-down nuts (C) and (A).
- ☞ Place the jack handle tubes (D) back in the tool kit.



CAUTION!

Check the tilt rod (H), split pin (K) and safety cable (G) at regular intervals for cracks and cuts.

- ☞ Replace defective parts immediately.

Tightening torques for high-resistance screw connections

With coarse-pitch thread, torques in lb.-ft. (Nm)					
Thread	Screws according to DIN 912, DIN 931, DIN 933, etc.			Screws according to DIN 7984	
	Grade 7 (8.8)	Grade 8 (10.9)	Grade 10 (12.9)	Grade 7 (8.8)	Grade 8 (10.9)
M5	4.0 (5.5)	6 (8)	7 (10)	4 (5)	5 (7)
M6	7 (10)	10 (14)	13 (17)	6.3 (8.5)	9 (12)
M8	18 (25)	26 (35)	31 (42)	15 (20)	22 (30)
M10	33 (45)	48 (65)	59 (80)	30 (40)	44 (59)
M12	64 (87)	81 (110)	108 (147)	51 (69)	74 (100)
M14	100 (135)	133 (180)	170 (230)	81 (110)	118 (160)
M16	155 (210)	203 (275)	258 (350)	125 (170)	184 (250)
M18	207 (280)	302 (410)	354 (480)	181 (245)	254 (345)
M20	302 (410)	420 (570)	509 (690)	251 (340)	361 (490)
M22	406 (550)	575 (780)	686 (930)	339 (460)	487 (660)
M24	524 (710)	738 (1000)	878 (1190)	435 (590)	620 (840)
M27	767 (1040)	1092 (1480)	1305 (1770)	642 (870)	922 (1250)
M30	1047 (1420)	1482 (2010)	1770 (2400)	885 (1200)	1254 (1700)











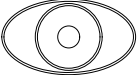





DIN 912 – hexagon socket head cap screw; DIN 931/DIN 933 – hexagon head screw with/without shaft;
 DIN 7984 – hexagon socket head cap screw with short head
 All values subject to a friction coefficient of $\mu = 0.12$ and are to be used as approximate figures.

With fine-pitch thread, torques in lb.-ft. (Nm)					
Thread	Screws according to DIN 912, DIN 931, DIN 933, etc.			Screws according to DIN 7984	
	Grade 7 (8.8)	Grade 8 (10.9)	Grade 10 (12.9)	Grade 7 (8.8)	Grade 8 (10.9)
M8X1.0	18 (25)	27 (37)	32 (43)	16 (22)	24 (32)
M10X1.0	37 (50)	55 (75)	65 (88)	32 (43)	48 (65)
M10X1.25	36 (49)	52 (71)	61 (83)	31 (42)	46 (62)
M12X1.25	64 (87)	96 (130)	111 (150)	55 (75)	81 (110)
M12X1.5	61 (83)	92 (125)	107 (145)	53 (72)	77 (105)
M14X1.5	100 (135)	148 (200)	173 (235)	89 (120)	129 (175)
M16X1.5	155 (210)	229 (310)	266 (360)	133 (180)	195 (265)
M18X1.5	232 (315)	332 (450)	391 (530)	199 (270)	284 (385)
M20X1.5	325 (440)	465 (630)	538 (730)	277 (375)	391 (530)
M22X1.5	435 (590)	620 (840)	723 (980)	369 (500)	524 (710)
M24X2.0	546 (740)	789 (1070)	922 (1250)	465 (630)	664 (900)
M27X2.0	811 (1100)	1143 (1550)	1328 (1800)	679 (920)	959 (1300)
M30X2.0	1106 (1500)	1586 (2150)	1844 (2500)	959 (1300)	1364 (1850)

DIN 912 – hexagon socket head cap screw; DIN 931/DIN 933 – hexagon head screw with/without shaft;
 DIN 7984 – hexagon socket head cap screw with short head
 All values subject to a friction coefficient of $\mu = 0.12$ and are to be used as approximate figures.

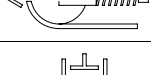
3.2 Maintenance label

Explanation of symbols on the maintenance label

Symbol	Assembly	Explanation
	General	Visual check
	General	Grease instructions
	Fuel system	Drain condensation water
	Fuel system	Replace the fuel filter, clean the fuel prefilter
	Radiator	Check the coolant level
	Radiator	Drain and fill in new coolant
	Engine	Check valve tip clearance. Adjust if necessary
	Engine	Check the engine oil level
	Engine	Change the engine oil
	Engine	Replace the oil filter
	Engine	Check V-belt tension
	Travel drive	Change oil
	Travel drive	Check oil
	Undercarriage	Check chain tension
	Hydraulic system	Check oil level
	Hydraulic system	Change the hydraulic oil
	Hydraulic system	Replace the hydraulic oil filter, replace the breather filter

Emptying the fuel tank

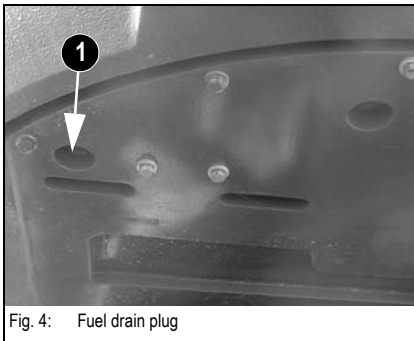

Fig. 4: Fuel drain plug



DANGER!

Do not allow draining fuel to contact hot engine parts or the exhaust system to avoid an increased

Risk of burns.

Do not bleed the fuel system if the engine is hot.

Due to the formation of condensation in the fuel tank, empty the fuel tank every 500 hours as follows:

- Place a container with sufficient capacity underneath the drain plug 1/Fig. 3 in the chassis.
- Open the drain plug to drain the fuel.
- Check the fuel tank for contamination and clean if necessary.
- Replace the filter according to the maintenance specifications.
- Screw the drain plug back in correctly.
- Fill the fuel tank.
- Bleed the fuel system according to "Bleeding the fuel system" on page 3-12.

Fuel shut-off valve and water separator

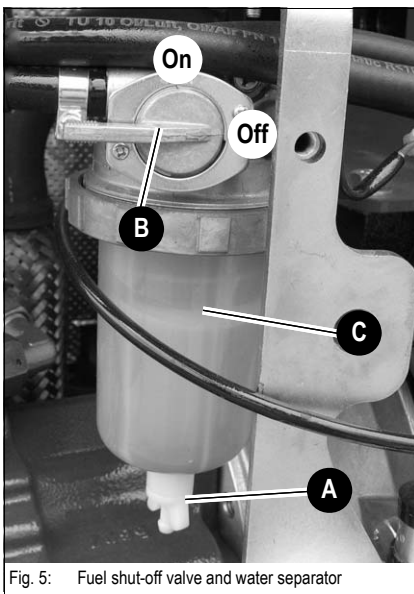

Fig. 5: Fuel shut-off valve and water separator

If water is seen in the water separator bowl, or the indicator ring rises to position C, the separator needs to be drained.

- Twist the fuel shut-off valve B to the Off position as shown.
- Unscrew plug A.
 - Wait until the indicator ring returns to the bottom of the water separator.
- Tighten plug A.
- Twist the fuel shut-off valve B to the On position.



Environment!

Collect the water as it drains into a suitable container and dispose of it according to environmental laws.

Weekly functional check of the dust valve

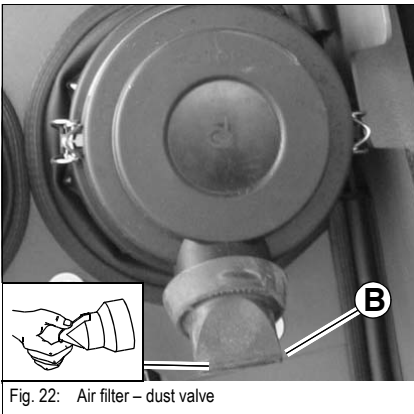

Fig. 22: Air filter – dust valve

➤ Proceed as follows:

- Turn off the engine.
- Fold up the control lever base.
- Remove the key and keep it with you.
- Let the engine cool down.
- Open the engine cover.
- Squeeze the discharge slot of dust valve **B**.
- Remove hardened dust by compressing the upper area of the valve.







➤ Clean the discharge slot if necessary.

3.12 Test report

Pilot control

Function	Movement	Symbol	Pressure limiting valve	Measuring port	Specified values		Measured	✓
Joystick	ANY		Pressure limiting valve PRV 4 (control oil unit)	Measuring port MP 4 (pump)	Rated value	507±44 psi (35±3 bar)		

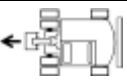
Pump 1

Function	Movement	Symbol	Pressure limiting valve	Measuring port	Specified values		Measured	✓
Boom	UP		Primary pressure limiting valve PPL V 1 (main valve block)	Measuring port MP 1 (pump)	Rated value	3481±44 psi (240±3 bar)		
	DOWN				Drop	348 psi (24 bar)		
Bucket	EXTEND				Rated value	3481±44 psi (240±3 bar)		
	RETRACT				Drop	348 psi (24 bar)		
Left-hand side drive	FORWARD				Rated value	3481±44 psi (240±3 bar)		
	REVERSE				Drop	348 psi (24 bar)		

CLICK HERE TO **DOWNLOAD** THE COMPLETE MANUAL

- Thank you very much for reading the preview of the manual.
- You can download the complete manual from: www.heydownloads.com by clicking the link below



- Please note: If there is no response to CLICKING the link, please download this PDF first and then click on it.

CLICK HERE TO **DOWNLOAD** THE COMPLETE MANUAL

3.14 Tracks

- Track wear may vary according to work and ground conditions.
 - ☞ We recommend checking track wear and tension daily.
 - ☞ Park the machine on firm and level ground when performing track maintenance.

Checking track tension



DANGER!

Working under the machine with the tracks off the ground and only supported by the attachment is extremely dangerous.

Risk of injury.

☞ Firmly support the machine with chocks or appropriate brackets.

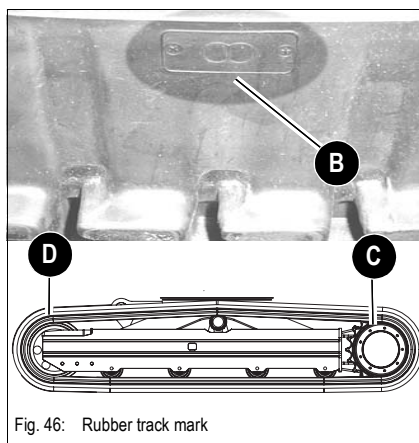

Fig. 46: Rubber track mark

Check track tension as follows:

- The rubber track has a mark **B** as shown in Fig. 46.
 - ☞ Place the excavator so that mark **B** of the rubber track is between the drive pinion **C** and the track tension roller **D**.

NOTE:

There is no mark on the steel tracks (option). Positioning the steel tracks is not necessary.

- No specific position is required for steel tracks (option).

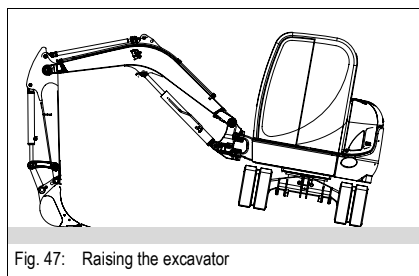

Fig. 47: Raising the excavator

- ☞ Park the machine on firm and level ground.
- ☞ Raise the excavator with the boom and the dipper arm as shown in Fig. 47.
 - ☞ Slowly and carefully actuate the control levers.
- ☞ Turn off the engine.
- ☞ Remove the key and keep it with you.
- ☞ Fold up the control lever base.
- ☞ Use appropriate auxiliary means to support the machine.

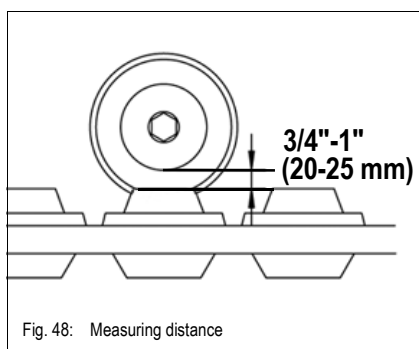
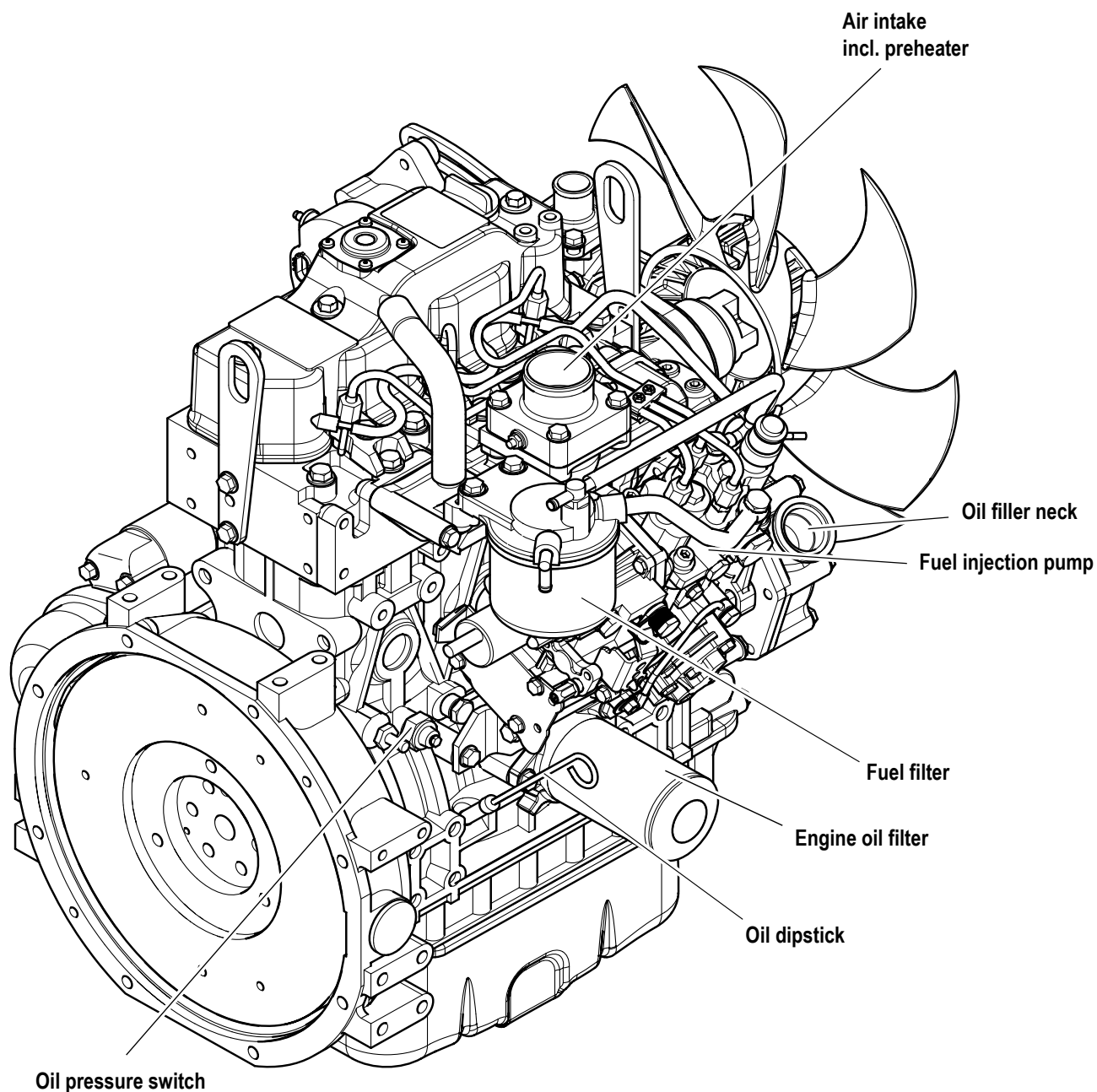

Fig. 48: Measuring distance

- Standard play between the sliding block's shoulder and the contact area of the second support roller of the drive pinion is 3/4" – 1" (20 – 25 mm).
 - ☞ Set the tension if it is not in accordance with the rated value.

4 Engine

4.1 3TNV88-PNS engine: overview



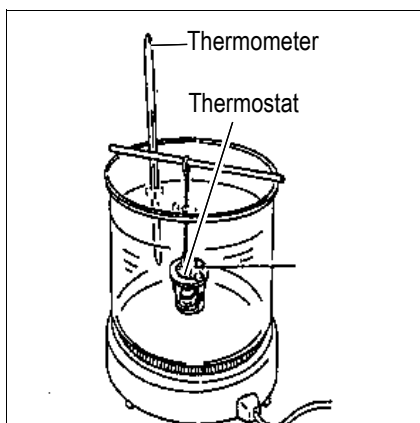

- ☞ Heat the thermostat in a container with water.
- ☞ Using a thermometer, check whether the thermostat opens at 157.1 – 162.5 °F (69.5 – 72.5 °C).

4.11 Checking the thermal switch

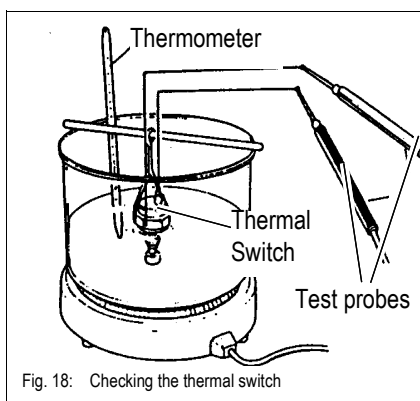

Fig. 18: Checking the thermal switch

- ☞ Remove the thermal switch.
- ☞ Heat the thermal switch in a container with antifreeze or oil.
- ☞ Using an ohmmeter, measure the resistance of the thermal switch.
 - ➔ The switch must allow the coolant to pass at a temperature of 225 – 235 °F (107 – 113 °C).

4.12 Oil pressure switch

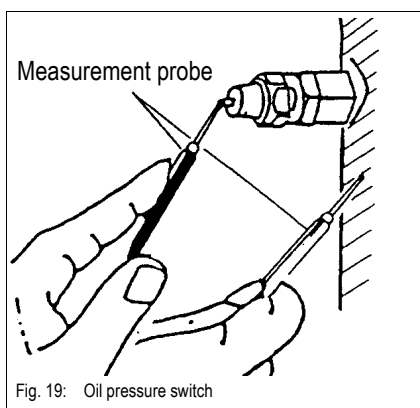
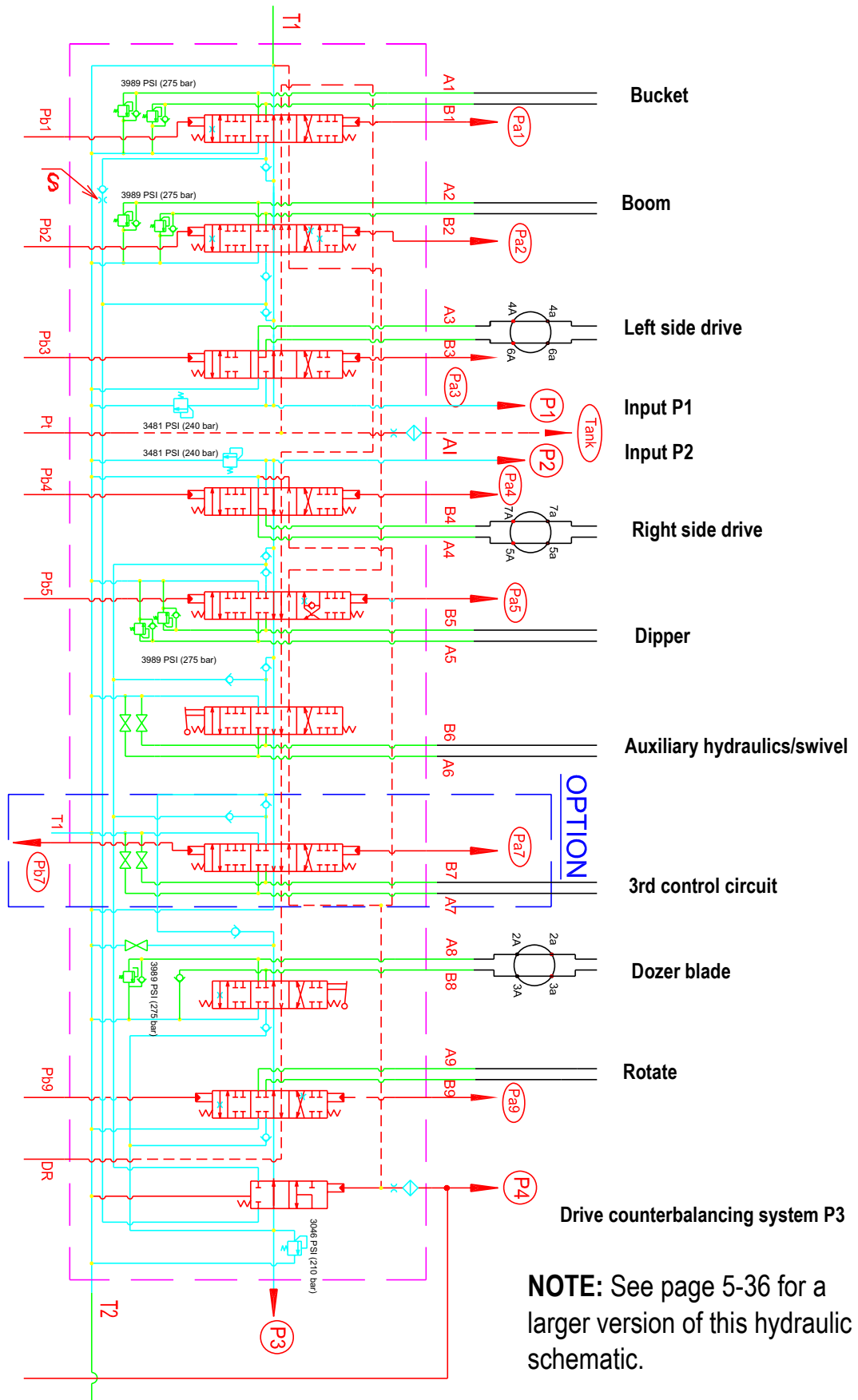

Fig. 19: Oil pressure switch

- ☞ Remove the cable connection from the oil pressure switch (in the area of the cut-off solenoid).
- ☞ Start the engine; check for correct idling speed (1050 +/- 50 rpm).
- ☞ Using an ohmmeter, measure the resistance of the oil pressure switch.
 - ➔ Infinite resistance indicates the oil pressure switch is OK.
 - ➔ The oil pressure switch is defective if the oil can pass.

Main valve block diagram



NOTE: See page 5-36 for a larger version of this hydraulic schematic.

5.8 Valves

7/2 directional valve (changeover valve)

The 7/2 directional valve (changeover valve) switches from auxiliary hydraulics (valve de-energized) to boom swivel and vice versa (valve energized).

The 7/2 directional valve is electrically controlled via a push button on left side joystick.

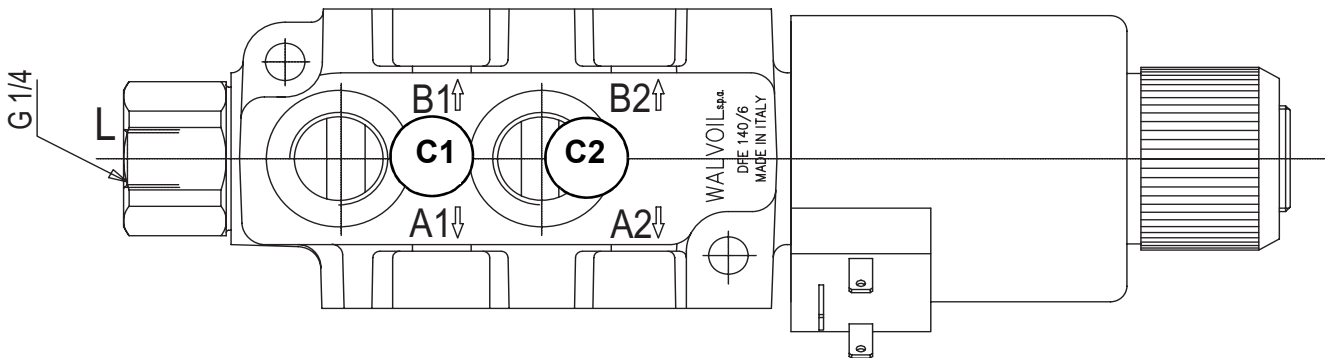
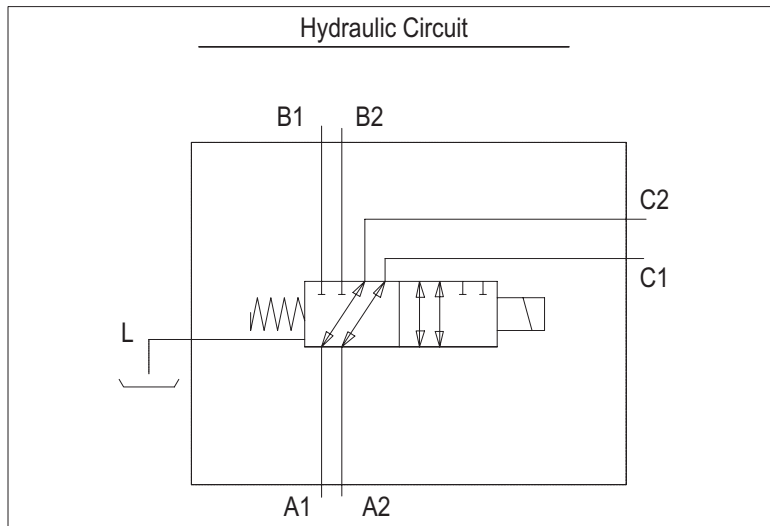

Ref. No.	Port
A1	Main valve block
A2	Main valve block
B1	Swivel
B2	Swivel
C1	Auxiliary hydraulics
C2	Auxiliary hydraulics
L	Return oil

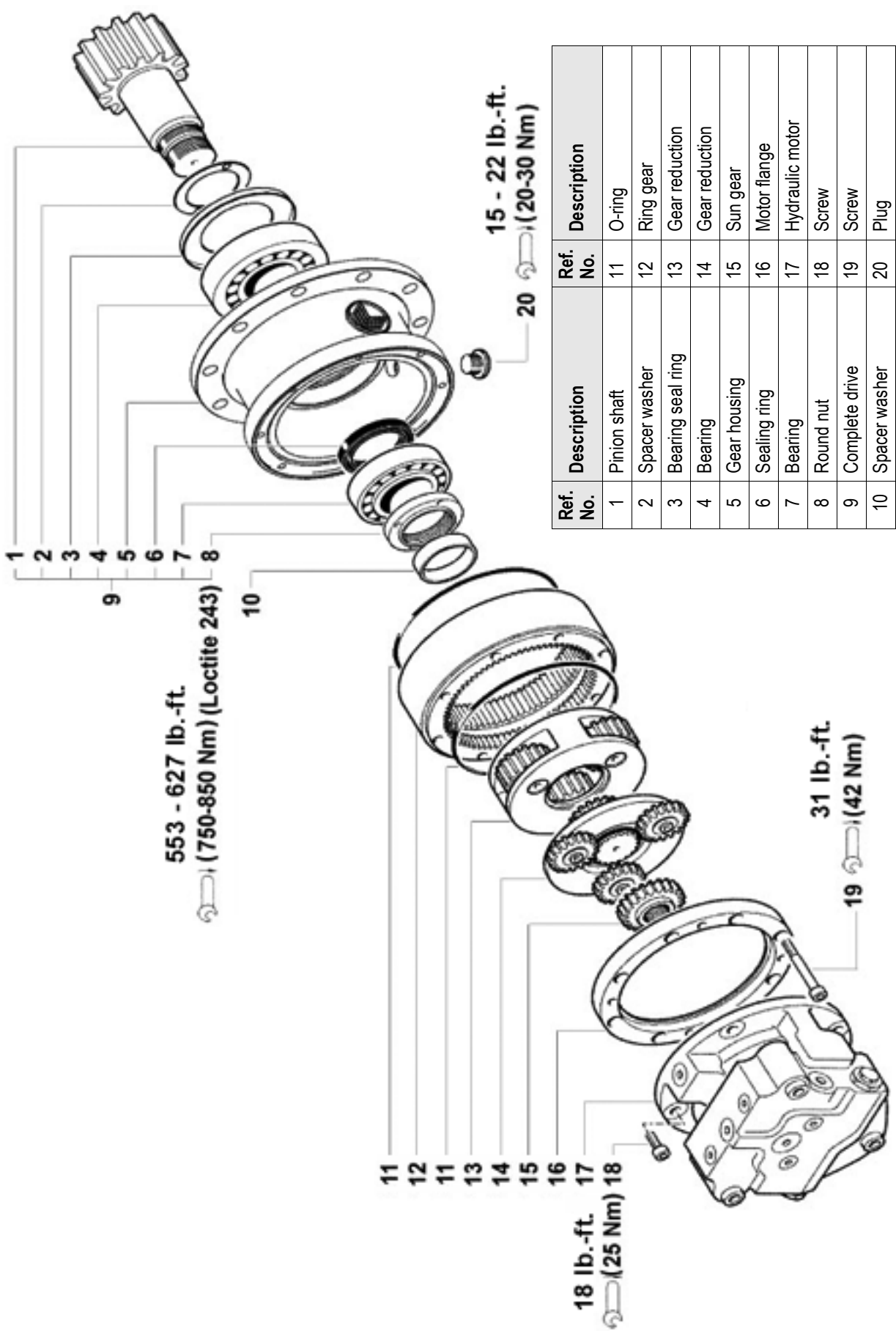

Ref. No.	Description	Ref. No.	Description
1	Pinion shaft	11	O-ring
2	Spacer washer	12	Ring gear
3	Bearing seal ring	13	Gear reduction
4	Bearing	14	Gear reduction
5	Gear housing	15	Sun gear
6	Sealing ring	16	Motor flange
7	Bearing	17	Hydraulic motor
8	Round nut	18	Screw
9	Complete drive	19	Screw
10	Spacer washer	20	Plug

6 Electrical system

6.1 Ohm's Law (current, voltage, resistance); power

It describes the interrelation between current, voltage and resistance.

Current "I" – Ampere (A)

Voltage "E" – Volt (V)

Resistance "R" – Ohm (Ω)

Mnemonic:

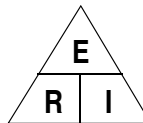

Output

Power "P" – Watt (W)

$$P = E \times I = R \times I^2 = E^2/R$$

6.2 Measuring equipment and methods

Multi-function measuring device

- Measurements of values (E, R, I, P)
- Continuity test
- Diode test

Calculate measuring range using known data (P, E, R, I) and set before measuring!

Observe AC/DC basic setting.

➡ AC = alternating current/voltage;

➡ DC = direct current/voltage

Test device with acoustic and optical signal output

- Continuity test in de-energized machine electric system and of wiring harnesses

6.16 Engine wiring harness

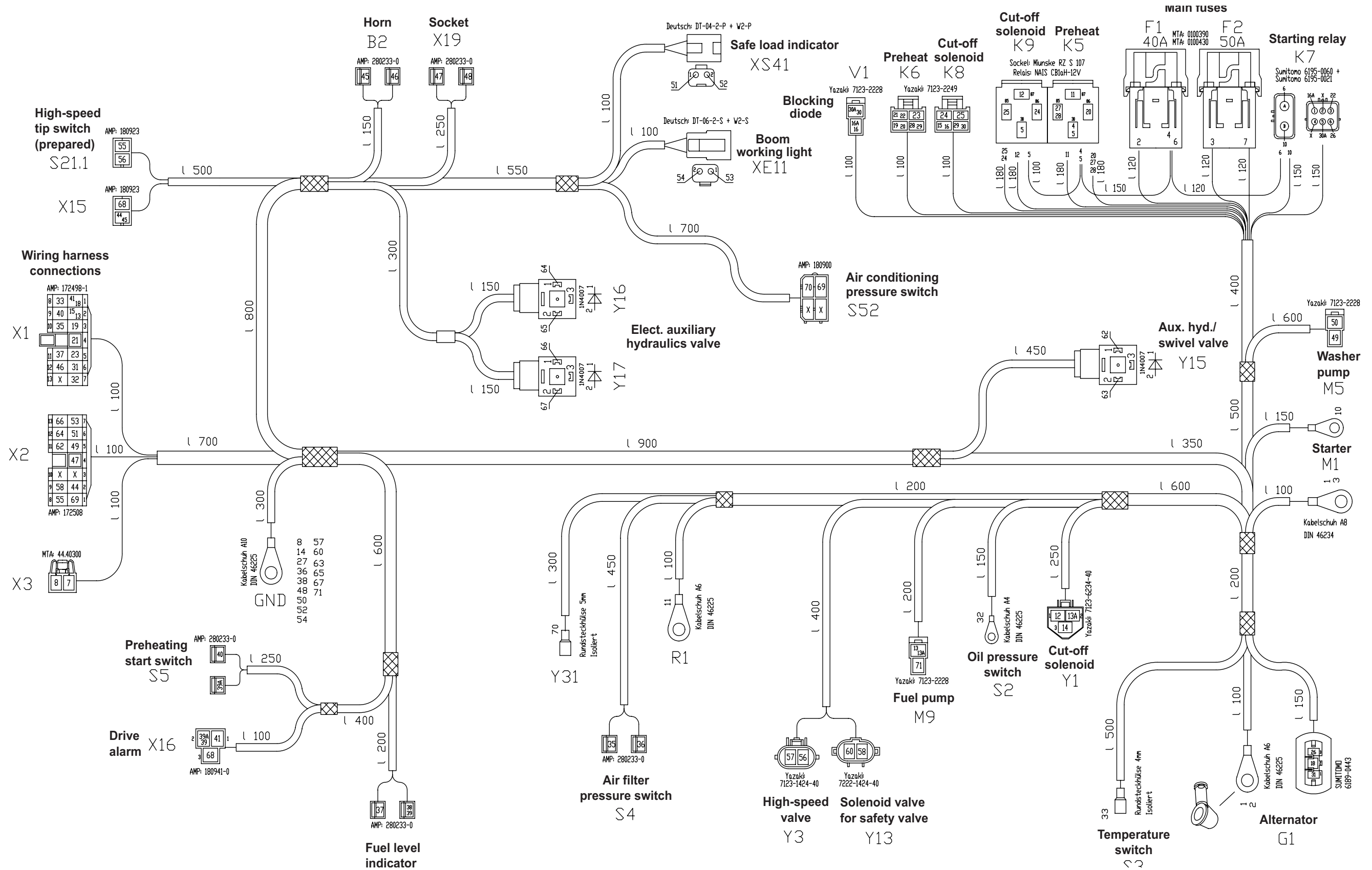

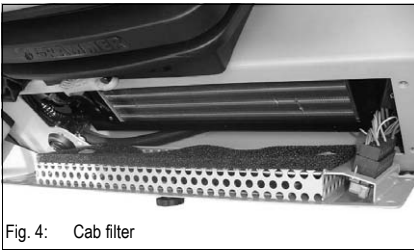

Fresh/recirculated air filter replacement

Remove the ventilation grill in the kick plate under the operator's seat to replace the filter. Use care not to overstretch the cables to the fuse box when tilting the grill.

Replacing the filter:

- Remove the screws securing the ventilation grill in the kick plate under the operator's seat.
- Tilt the grill as shown in Fig. 4.
 - Use care not to overstretch the cables to the fuse box when tilting the grill.
- Use a screwdriver to remove the cab filter.
- Insert a new filter into the filter housing.
- Replace the grill and tighten securely.

CLICK HERE TO **DOWNLOAD** THE COMPLETE MANUAL

- Thank you very much for reading the preview of the manual.
- You can download the complete manual from: www.heydownloads.com by clicking the link below



- Please note: If there is no response to CLICKING the link, please download this PDF first and then click on it.

CLICK HERE TO **DOWNLOAD** THE COMPLETE MANUAL