

8365 ENGINE

SERVICE MANUAL

CLICK HERE TO **DOWNLOAD** THE COMPLETE MANUAL

- Thank you very much for reading the preview of the manual.
- You can download the complete manual from: www.heydownloads.com by clicking the link below



- Please note: If there is no response to CLICKING the link, please download this PDF first and then click on it.

CLICK HERE TO **DOWNLOAD** THE COMPLETE MANUAL

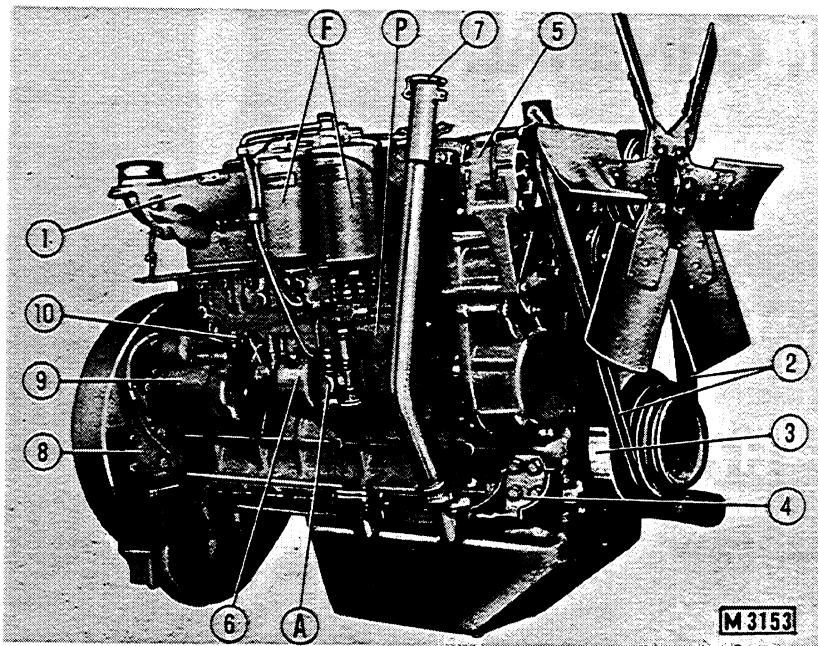

Fig. 2 - R.H. Side view of engine 8365.05.560 (fitted on crawler loader FL10-C.)

A. Fuel supply pump - F. Fuel filters - P. Injection pump - 1. Intake manifold
2. Alternator, water pump, and fan belts - 3. Damper - 4 and 8. Engine mounting brackets - 5. Alternator - 6. Speed regulator - 7. Oil filler and dipstick - 9. Starter motor - 10. Cylinder block water drain cock.

degrees before the piston reaches T.D.C.

When the finely atomized fuel is injected under extremely high pressure (about 200 bar - 2844 psi) into the combustion chamber, it immediately starts a partial ignition, owing to the very high air temperature.

The ignition of this part of fuel might be better considered an explosion. The sharp rise in temperature that follows and the movements of the air not yet involved in the combustion lead to a complete burning of the fuel which is still being injected into the combustion chamber.

Power and exhaust strokes follow.

So the operation cycle closes, which is achieved every two complete revolutions of the crankshaft.

1.2.2 REQUIREMENTS FOR INJECTION

According to what said above, we may sum up the requirements for a correct injection that will ensure top performance of the engine as follows :

a) Timing of the injection - Injection must always start at the same stage of

the cycle, chosen to be as close as possible to the ideal engine operating cycle. It must be possible to adjust this timing according to the engine speed (automatic advance adjustment).

b) Quantity of fuel injected. Injection into each cylinder and for each cycle of the same quantity of fuel required to provide the sufficient output. Of course it must be possible to adjust this quantity to the variations of the torque applied to the engine.

c) Way in which injection is achieved. The jet must have enough :

- atomization, so that it immediately ignites ;
- penetration through the compressed air;
- diffusion to all directions so that as much as possible of the air in the cylinder can be used for combustion.

This task is achieved by the injection system and by the pump and injectors in particular.

To prevent serious damage to the engine and injection system the utmost care should be taken when adjusting the pump flow to the engine to ensure a correct

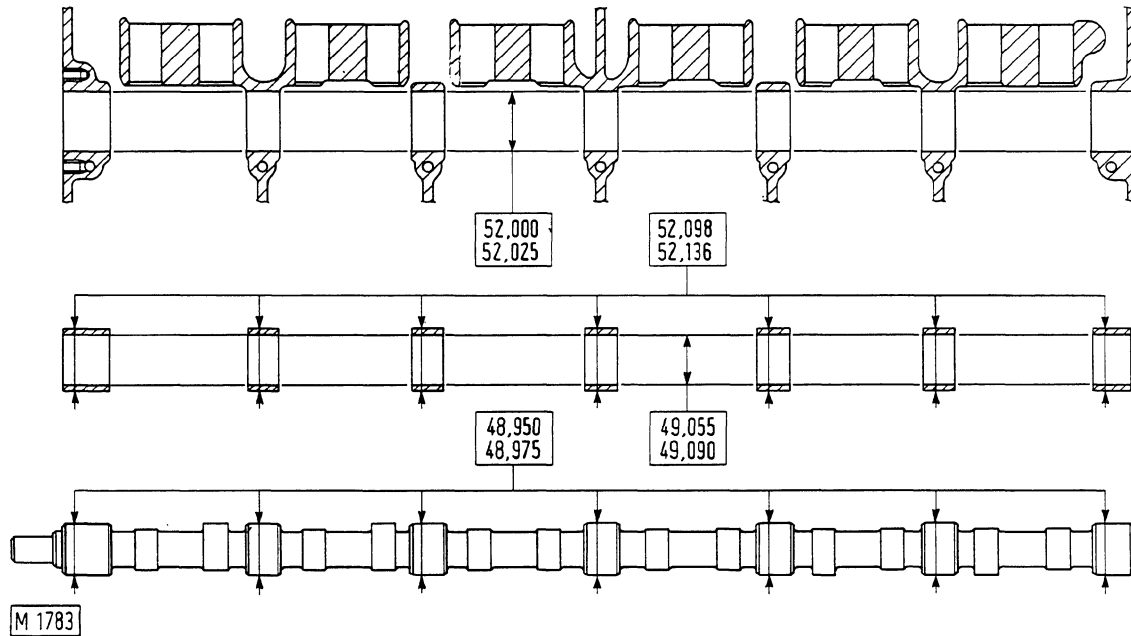

Fig. 15 - Dimensions of camshaft journals, bushings and relevant seats.

Note - Bushing inner diameter must be obtained by grinding after fitment.

If bushings are very slightly damaged , reface with a burnisher.

In case bushings are renewed, after fitment their bore should be reamed with mandril and milling cutters 75295830 to get an inner diameter of 49.055-49.090 mm (1.931-1.932 in).

Make sure camshaft journal and cam surfaces are smooth and bright. If they are seized or scored renew camshaft.

Only if damage is very slight, it can be eliminated with very fine grade emery cloth.

Moreover check camshaft for straightness: a micrometer gauge placed on the camshaft center journal should not indicate variations greater than 0.20 mm (0.008 in) ; if higher values are indicated the camshaft cannot be straightened with a press and it should be renewed.

NOTE - In case gear (2, fig.14) should be renewed, install thrust plate (1) on the camshaft and heat gear (2) in oven to obtain a difference in temperature bet-

ween camshaft and gear of about 240°C (464°F).

Install gear on the shaft and check end play between gear and thrust plate to be 0.060-0.110 mm (0.0023-0.0043 in). In case the camshaft has to be renewed, the spare comes complete with gear and thrust plate.

3.2 VALVES AND VALVE GUIDES

To dismantle the valves remove cylinder head, compress springs with tool 75291050 (fig.17) and remove split cone keepers (1).

Thoroughly clean valves and check that stem and seat are not cocked or show signs of seizing or scoring; if damaged renew valves.

If required, it is possible to grind the rocker arm at its point of contact with the valve stem. Remove as little material as possible as the thickness of the hardened material is 2-3 mm (0.08-0.12 in).

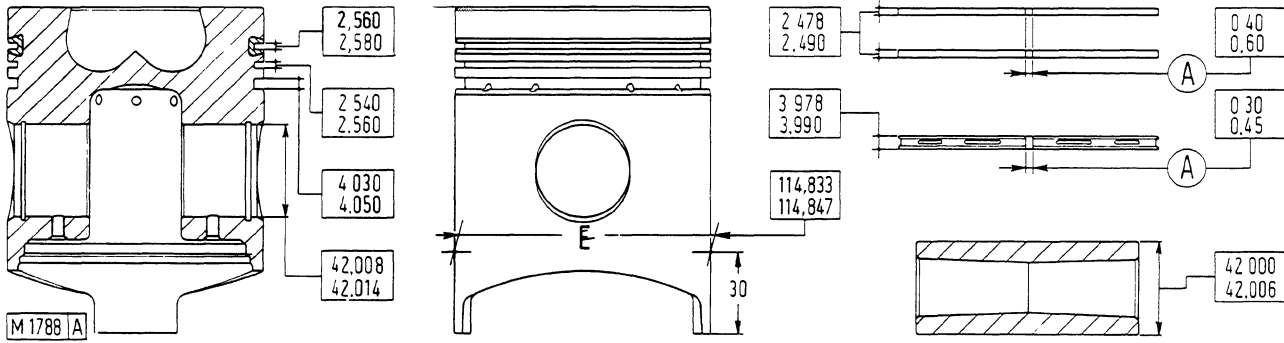

Fig. 32 - Standard dimensions of pistons, pins and rings.

A. Gap to be measured with rings installed in sleeves - E. Max. piston skirt ellipse diameter measured at 30 mm (1.18 in) above bottom of skirt (to check piston-sleeve fit).

25.4 mm - 1 inch

- pistons must be the same oversize class as their sleeves.

+0.614 mm (0.0241 in)(protrusion) or -0.298 mm (0.0117 in) (inset).

Pistons and rings are supplied as spare with oversized outer diameter of 0.60 mm (0.0236 in).

4.3.2 CHECKING RING-TO-GROOVE CLEARANCE

Installation of pistons with rings and connecting rods must be done as shown in fig. 30 by means of piston ring clamp 75291048 (A).

Check must be made as indicated in fig. 34, installing ring in the groove and then measuring with a feeler gauge. If clearance exceeds max. permissible figure renew rings.

Be sure numbers stamped on connecting rods (fig. 33) correspond with respective cylinders and are on the side opposite the camshaft (V).

Ring-to-groove clearances :

- 1st chromed ring.... 0.070-0.102 mm (0.0027-0.0040 in)
- 2nd ring 0.050-0.082 mm (0.0019-0.0032 in)
- 3rd oil scraper ring.0.040-0.072 mm (0.0015-0.0028 in)

With a magnetic mount gauge (fig.31) check piston T.D.C. protrusion or inset with respect to the block deck to be

4.3.3 CHECKING PISTON RING GAP

Check must be made with rings in the sleeves; gap must be measured with a feeler gauge.

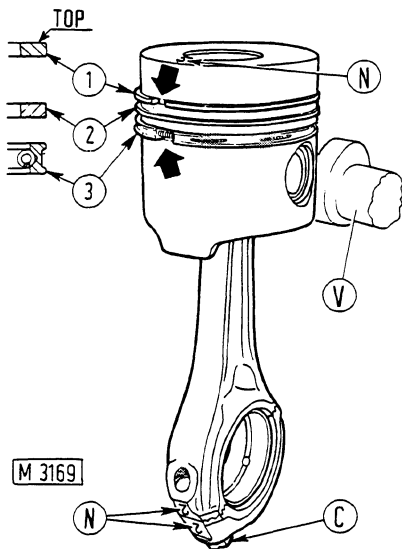

Fig. 33 - Correct piston-rod assembly.

Note - Arrows indicate ring gaps which must be 180° from each other.

C.Connecting rod cap selflocking screws - N.Number of corresponding cylinder - V.Camshaft - 1 and 2. Piston rings - 3. Oil scraper ring.

6. LUBRICATION

NOTE - Lubrication system layout is to be found in the "Engine related components" manual of your particular machine.

Refer to the same manual for disassembly and overhaul of oil filters and heat exchangers.

6.1 OIL PUMPS

To remove the pumps remove oil pan and then suction and delivery lines and screws (C₁, fig. 48).

To disassemble the pumps remove pump body retaining screws (C₂) and then disassemble.

When reassembling bear in mind the following :

- the outer control gear (4), cover(1), spindle (3) and gear (2) are supplied together as spare ;
- rear cover (10) and spindle (9) are supplied together as spare.

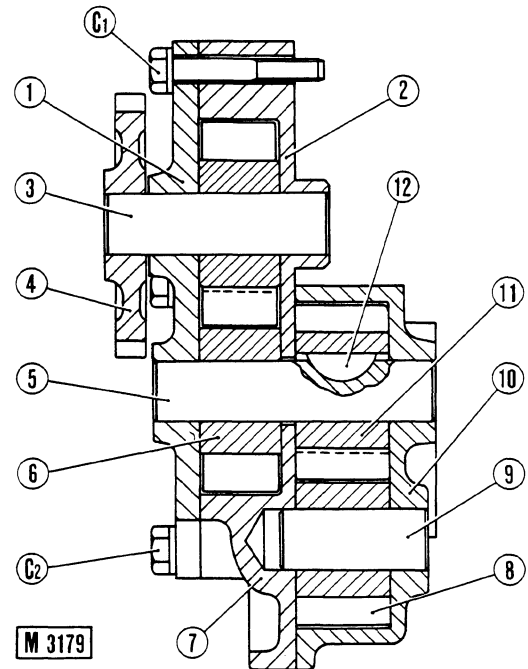

Fig. 48 - Oil pump section view.

C₁.Screws securing oil pump to block - C₂.Oil pump retaining screws - 1. Support with gears (2 and 4) and spindle (3) (supplied together as spare) - 5. Spindle with gear (6) (supplied together as spare) - 7. Pump body - 8 and 11. Scavenge pump gears - 10. Rear cover with spindle (9) (supplied together as spare) - 12. Gear (11) retaining key on spindle (5).

TROUBLE	CAUSE	REMEDY
	8 Camshaft bearings worn 9 Fuel in engine oil	8 Replace bearings 9 Locate and repair fuel leak Replace engine oil and filters.
15. Excessive lubricating oil pressure	1 Oil pressure gauge inaccurate. 2. Improper lubricant.	1. Check gauge and replace if necessary 2 Top up with specified lubricant
16. Overheating of lubricating oil.	1. Insufficient lubricating oil. 2 Lubricant not of correct grade 3. Engine oil cooler clogged or bypass valve defective. 4 Oil level too high 5. Worn water pump or inefficient cooling system	1 Top up 2 Use only specified lubricant 3 Clean or replace the oil cooler. 4 Restore to proper level 5 Check system Replace pump if necessary
17 Excessive oil consumption.	1 Oil level too high 2 Oil leakage (through gaskets, etc.). 3. Oil seals worn or damaged 4. Lubricating oil too light 5. Pistons, rings and/or cylinder sleeves worn 6. Piston and oil control rings stuck in grooves 7 High engine oil temperature 8 Valve guides worn	1 Restore to proper level 2. Eliminate any external leaks 3. Replace oil seals 4. Use specified lubricant only 5. Replace affected parts 6. Clean ring grooves and replace rings 7 See preceding point 8 Replace valve guides Check related parts

(*) For turbocharged engines

Catalogue No.	Designation
75295830	Reamer for camshaft journal seats
75291050	Spring compressor for engine valve spring (fig.17)
75292867	Valve guide measuring set
75290944	Valve guide reamer
75291046	Driver to remove-install valve guides (fig. 18)
75290947	Valve lifter remover-installer (fig. 20)
	<u>CRANK MECHANISM</u>
75290090	Rotating engine stand (fig. 25)
75291048	Piston ring clamp for piston installation (fig. 30)
75291160	Piston ring installer (fig. 35)
75292172	Connecting rod squareness checking fixture (fig.37)
75291243	Expansion type reamer for connecting rod small end bushing
	<u>FUEL SYSTEM</u>
75290898	Tool to remove injectors
75291337	Wrench to remove injectors
	<u>TROUBLESHOOTING AND TESTS</u>
75295633	Dummy injector for engine compression test (use with compression meter 75291310).

SAFETY RULES

Follow the recommendations of the manufacturer for storage and disposal.

Wire rope develops steel slivers. Use authorized protective equipment such as heavy gloves, safety glasses when handling.

OPERATION

Before starting machine, check, adjust and lock the operator's seat for maximum comfort and control of the machine.

DO NOT START OR OPERATE AN UNSAFE MACHINE. Before working the machine, be sure that any unsafe condition has been satisfactorily remedied. Check brakes, steering and attachment controls before moving. Advise the proper maintenance authority of any malfunctioning part or system. Be sure all protective guards or panels are in place, and all safety devices provided are in place and in good operating condition.

Check instruments at start-up and frequently during operation.

Do not run the engine of this machine in closed areas without proper ventilation to remove deadly exhaust gases.

Be sure exposed personnel in the area of operation are clear of the machine before moving the machine or its attachments. **WALK COMPLETELY AROUND** machine before mounting. Sound horn. Obey flag man, safety signals and signs.

Know the principles of cross steering of crawler tractors. Read section in Operation and Maintenance Instruction Manual on cross steering.

Keep engine exhaust system and exhaust manifolds clear of combustible material. Equip machine with screens and guards when working under conditions of flying combustible material.

If engine has a tendency to stall for any reason under load or idle, report this for adjustment to a proper maintenance authority immediately. Do not continue to operate machine until condition has been corrected.

Never use bucket as a man-lift.

Use recommended bucket for machine and material loadability and heaping characteristics of material, terrain, and other pertinent job conditions.

Avoid abrupt starts and stops when transporting a loaded bucket.

Inspect your seat belt webbing and hardware at least twice a year for signs of fraying, wear or other weakness that could lead to failure.

Use only designated towing or pulling attachment points. Use care in making attachment. Be sure pins and locks as provided are secure before pulling. Stay clear of draw bars, cables or chains under load.

When pulling or towing through a cable or chain, do not start suddenly at full throttle. Take up slack carefully. Guard against kinking chains or cables. Inspect carefully for flaws before using. Do not pull through a kinked chain or cable due to the high stresses and possibility of failure of the kinked area. Always wear heavy gloves when handling chain or cable.

Be sure cables are anchored and the anchor point is strong enough to handle the expected load. Keep exposed personnel clear of anchor point and cable or chain. **DO NOT PULL OR TOW UNLESS OPERATOR'S COMPARTMENT OF MACHINES INVOLVED ARE PROPERLY GUARDED AGAINST POTENTIAL CABLE OR CHAIN BACKLASH.**

During operation always carry ripper in full raised position when not in use and lowered to ground when parked.

When counterweights have been provided, do not work machine if they have been removed unless their equivalent weight has been replaced. See the Operation and Maintenance Instruction Manual.

When operating a machine know what clearances will be encountered, overhead doors, wires, pipes, aisles, roadways; also the weight limitations of ground, floor, and ramps.

Know bridge and culvert load limits and do not exceed them. Know machine's height, width, and weight. Use a signal person when clearance is close.

Be sure that the exact location of gas lines, utility lines, sewers, overhead and buried power lines, and other obstructions or hazards are known. Such locations should be precisely marked by the proper authorities to reduce the risk of accidents. Obtain shut-down or relocation of any such facilities before starting work, if necessary. Be certain to comply with all local, state, and federal regulations regarding working in the vicinity of power lines.

When roading find out what conditions are likely to be met clearances, congestion, type of surface, etc. Be aware of fog, smoke or dust element that obscure visibility.

When backing, always look to where the machine is to be moved. Be alert to the position of exposed personnel. **DO NOT OPERATE** if exposed personnel enter the immediate work area.

Never travel a machine on a job site, in a congested area, or around people without a signal person to guide the operator.

In darkness, check area of operation carefully before moving in with machine. Use all lights provided. Do not move into area of restricted visibility.

Maintain clear vision of all areas of travel or work. Keep cab windows clean and repaired. Carry blade low for maximum visibility while traveling. Obtain and use fan blast deflectors where tractors are used a pusher tractors in tandem.

Transport a loaded bucket with the bucket as far tipped back and in as low a position as possible for maximum visibility, stability, and safest transport of the machine. Carry it at a proper speed for the load and ground conditions.

Carry the bucket low when traveling with a load.

FOREWORD

Always furnish serial number if making an inquiry to dealer or factory about this machine.

Many equipment owners employ the Dealer Service Department for all work other than routine lubrication and minor service. This practice is encouraged, as our Dealers are well informed and equipped to render efficient service by factory trained mechanics.

This manual may not be reprinted or reproduced, either in whole or in part, without written permission of Fiatallis ®.

Illustrations show standard and optional items.

IMPORTANT

The information in this manual was current at the time of publication. It is our policy to constantly improve our product and to make available additional items. These changes may affect procedures outlined in this manual. If variances are observed, verify the information through your Dealer.

Fiatallis is not responsible for any liability arising from any damage resulting from defects caused by parts and/or components not approved by Fiatallis for use in maintaining and/or repairing products manufactured or merchandized by Fiatallis.

In any case, no warranty of any kind is made or shall be imposed with respect to products manufactured or merchandized by Fiatallis when failures are caused by the use of parts and/or components not approved by Fiatallis.

1.4 REPAIR PROCEDURES

1.4.1 1 13

Drain converter housing.

T-93549

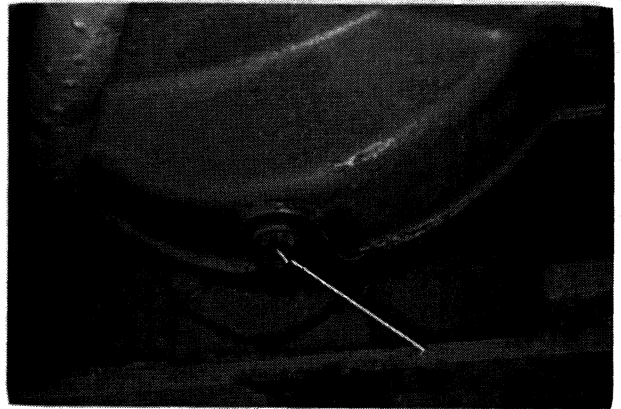

1 4.1 1 14

Disconnect alternator wires from alternator and two clamping positions.

T-93551

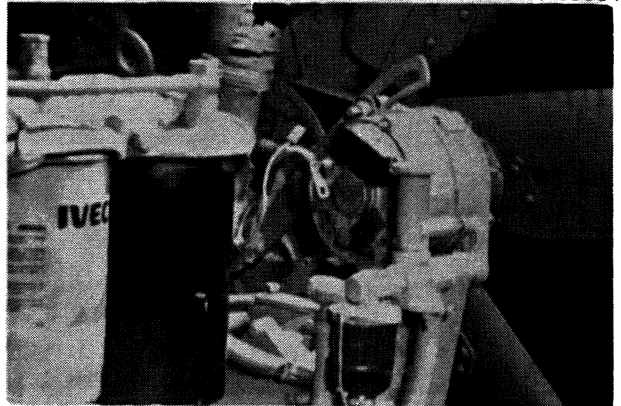

1.4.1 1 15

Disconnect fuel inlet line and fuel return line.

T-93550

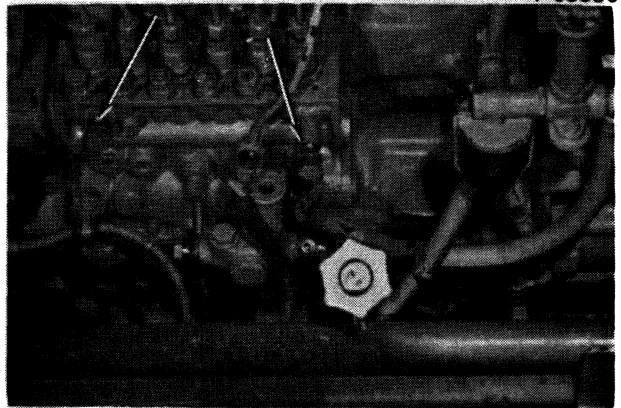

1.4.1 1 16

Disconnect wire to overLift and handle all heavy parts

T-93552

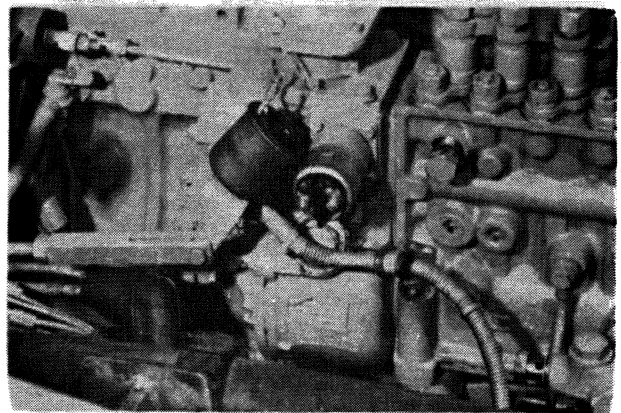

Study **SAFETY RULES** in the front of this manual thoroughly for the protection of machine and safety of personnel.

1.4 REPAIR PROCEDURES

1.4.3 STARTER

T-93515

1.4.3.1 REMOVAL

1.4.3.1.1

Turn master electrical switch to the "OFF" position. Tag the unit with a "DO NOT START" tag.



WARNING

Always turn the master switch to the "OFF" position before cleaning, repairing, servicing or parking the machine to prevent injury

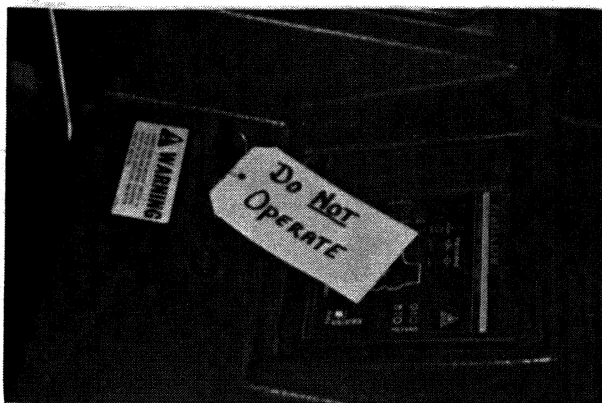

T-93400

1.4.3.1.2

Open right side engine access door.

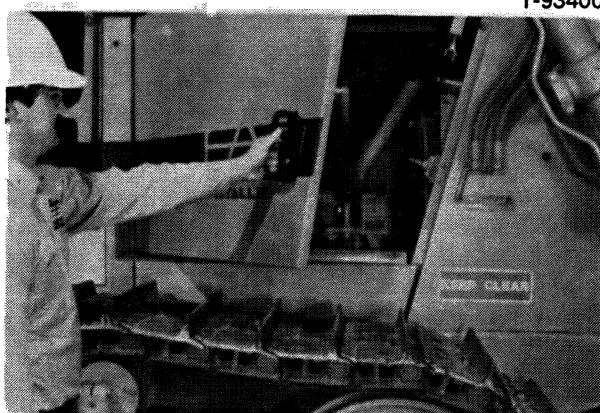

T-93432

1.4.3.1.3

Remove ground cable.

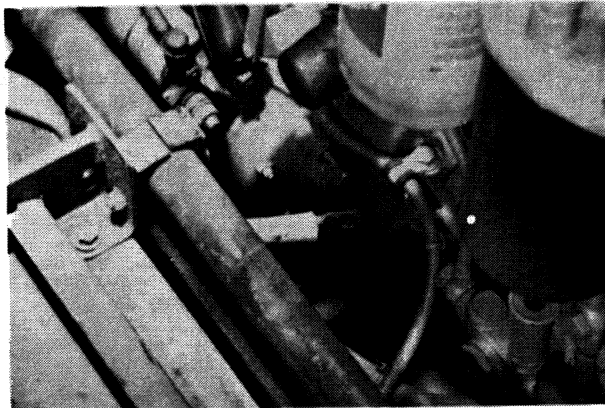

T-93433

1.4.3.1.4

Disconnect the starter wires.

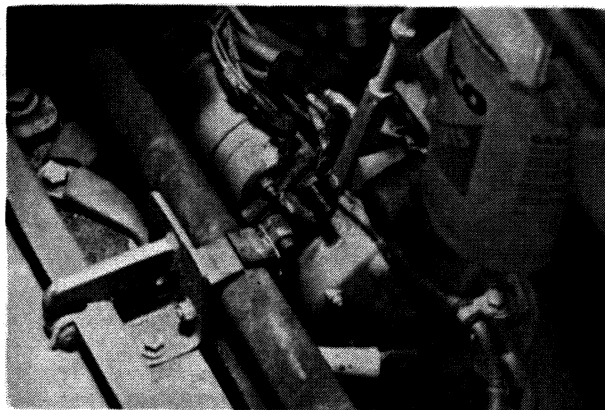

Study **SAFETY RULES** in the front of this manual thoroughly for the protection of machine and safety of personnel.

1.4 REPAIR PROCEDURES

1.4.6.2.12

Be sure throttle linkage is forcing the pump's fuel lever to the high idle position.

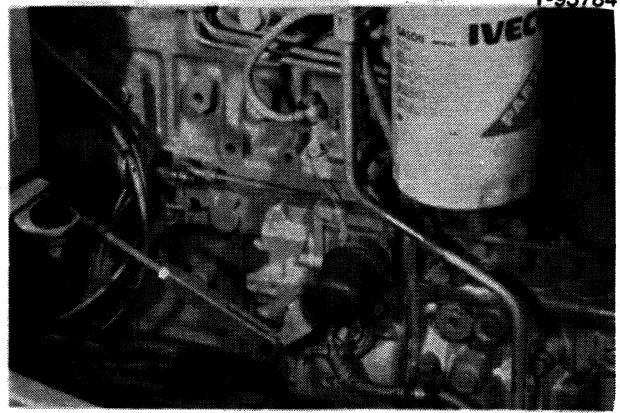

1.4.6.3 ELECTRIC FUEL SHUT OFF SOLENOID

Should replacement of the solenoid or linkage be necessary, adjust the length of the rod as follows:

With the key switch "OFF" position the fuel shut off lever to "OFF". Adjust the length of the rod by turning the ball joint "in" or "out" to achieve the proper length. The stroke of the solenoid is approximately 30mm (1.18 in).

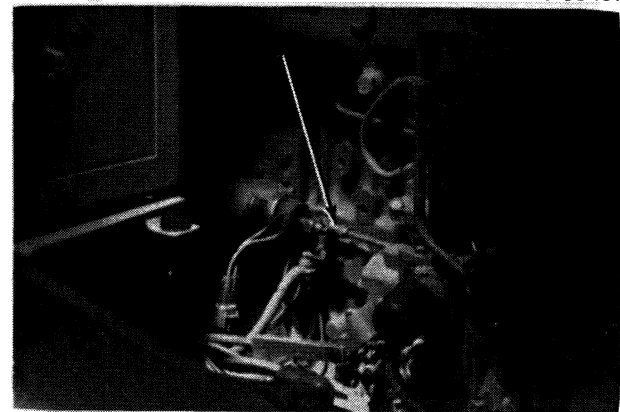

Study SAFETY RULES in the front of this manual thoroughly for the protection of machine and safety of personnel.

1.4 REPAIR PROCEDURES

T-93679

1.4.8.2.6

Operate the hand pump from the pressure timing tool so that a steady stream of fuel flows from the drip tube. As you operate the hand pump, slowly rotate the injection pump housing in the opposite direction of pump rotation in order to reach port closure. Rotate the pump until the flow just stops. **Do not let the pressure in fuel pump exceed 17 bar (250 psi) or damage to the fuel pump may result.**

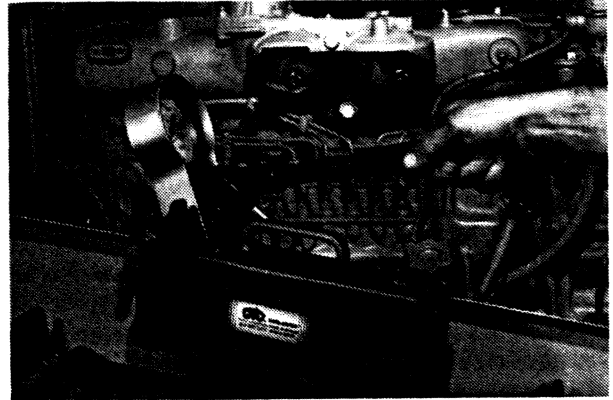

WARNING

Keep hands away from nozzle tip when testing a nozzle. The finely atomized fuel is ejected with sufficient force to penetrate the skin and cause blood poisoning. Also, wear safety glasses with side shields or goggles when testing a nozzle.

Keep hands and face away from the loosened line nuts while performing fuel line and nozzle tests. Also, wear safety glasses with side shields or goggles.

1.4.8.2.7

Fasten the fuel pump mounting capscrews to specified torque. The rest of the fuel pump installation is the reversal of the removal process. Be sure all capscrews are tightened to specified torque.

Study SAFETY RULES in the front of this manual thoroughly for the protection of machine and safety of personnel.

2.1 GENERAL DESCRIPTION

NEUTRAL

The transmission system is a full power shift transmission incorporating the necessary valving to make smooth transitions between directions and upshifting in the ranges. The transmission has three forward and three reverse ranges.

Oil is drawn from the transmission sump by the combination main supply (P_a) and torque converter (P_c) charging pump. The main supply pump directs the oil to the filter (F_m), which incorporates a cold oil relief valve, and then to the main pressure regulating valve. The main pressure regulating valve maintains a constant pressure in the clutch apply circuit. Any oil flow that is not needed for the main pressure circuit is diverted to the torque converter circuit. Oil in the main pressure circuit is directed from the pressure regulating valve to the neutral lock valve. When the neutral lock valve is in the locked position, oil cannot flow to the transmission manipulator valve or to the brake circuit.

Oil from the converter charging pump is directing oil to the converter where it joins with oil flowing past the main pressure regulating valve. Prior to going into the converter, oil is indexed to the converter relief valve (3), which prevents extreme high pressures within the converter in cold oil conditions. Oil fills the converter and transmits power to the converter causing the converter output shaft to rotate. Oil then leaves the converter and flow to the heat exchanger (S). Heat generated by the power transfer within the converter is removed through the oil to engine coolant heat exchanger. Oil is then directed to the lubrication oil manifold (16). The lubrication oil pressure is limited by the lubrication relief valve (17). Lubrication oil exiting the manifold is directed to the clutches and to the bearings.

Any oil leakage within the converter is scavenged from the converter through a suction screen (F_s) by pump (P_r). The scavenged oil is sent back to the transmission sump.

SECOND FORWARD

When the operator is ready to work, he shifts the neutral lock lever to the unlocked position. This directs oil to the manipulator (X) and to the brake circuit where the brakes are released. When in neutral oil is directed to the second range clutch only. When the operator shifts the manipulator lever, oil is directed through the valve and out the applicable passages. When the manipulator is shifted, oil can get on the bottom side of the opposite spool and force the spool up, locking the manipulator in one position. Oil coming from the manipulator is directed to the top of the forward spool and to both ends of the range spool. The forward spool is shifted down against its spring while the range spool stays in the centered position. Oil is directed from the main pressure regulating valve to the range spool area and to the direction spools area. Main pressure oil is directed to the second range trimmer valve and then to the second range clutch. The trimmer valve cushions the shift on upshifts by allowing a time delay before full clutch apply pressure is at the clutch.

At the forward spool oil is directed through the spool and to the forward trimmer valve. This valve also causes a time delay, but in this case only when shifting into forward. Once full clutch apply pressure is reached, the trimmer valve has no function.

- | | | |
|--|---|---------------------------------------|
| a. Selector valve in second forward | S. Heat exchanger | 7. Reverse clutch spool |
| A. Forward clutch | S _c . Low oil pressure indicator | 8. Trimmer check valve |
| C. Torque converter | T. Oil temperature gauge | 9. Plunger stem |
| D. Transmission control valve | V. Third range clutch | 10. Plunger |
| F _a . Suction filter | V _a . Forward trimmer valve | 11. Restrictor |
| F _m . Pressure filter | V _r . Reverse trimmer valve | 12. Dump valve |
| F _r . Scavenger pump filter | V _m . Range trimmer valve | 13. Spring |
| I. Reverse clutch | X. Manipulator valve | 14. Range spool |
| L. First range clutch | Y. Neutral lock valve | 15. Dump valve |
| M. Second range clutch | 1. Breather | 16. Lubrication manifold |
| P. Transmission pressure gauge | 2. Magnetic plug | 17. Lubrication pressure relief valve |
| P _a . Transmission main pressure pump | 3. Torque converter pressure relief valve | 18. Trimmer valve plunger |
| P _c . Torque converter charging pump | 4. Main pressure regulating valve | 19. Quick dump valve |
| P _r . Steering clutch pump | 5. Cold oil relief valve | 20. Spools |
| P _r . Torque converter scavenge pump | 6. Forward clutch spool | 21. Hand lever |
| | | 22. Orifice |

Study SAFETY RULES in the front of this manual thoroughly for the protection of machine and safety of personnel.

2.3 TESTING

TRANSMISSION TEST CHART

Customer _____ Date _____

Machine Model _____ S/N _____ Hrs. _____

Transmission S/N _____ General Machine Condition _____

Machine Application _____

	SPECIFICATION	TEST RESULTS
Normal operating temperature	50 -120°C (122-250°F)	
Engine speed, full throttle (no load)	2160 -2210 rpm	
Engine speed, converter stall	1790 1930 rpm	
Main pressure	16.5-17.5 bar (239-254 psi)	
1st Clutch pressure	16.5-17.5 bar (239-254 psi)	
2nd Clutch pressure	16.5-17.5 bar (239-254 psi)	
3rd Clutch pressure	16.5-17.5 bar (239-254 psi)	
Fwd Clutch pressure	14.5 15.5 bar (210-225 psi)	
Rev Clutch pressure	14.5 15.5 bar (210-225 psi)	
Lubricating oil pressure	3 bar (43 psi)	

Study SAFETY RULES in the front of this manual thoroughly for the protection of machine and safety of personnel.

2.4 REPAIR PROCEDURES

2.4.1.3.13

Unlock capscrews and remove bearing retaining plate.

T-88137

WARNING

It is unsafe to strike hardened steel parts with anything other than a soft iron or non-ferrous hammer. When installing or removing such parts wear safety glasses with side shields and heavy gloves, etc., to reduce the possibility of injury.

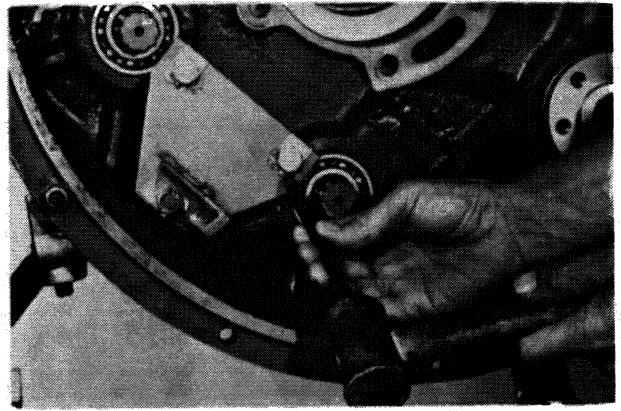

2.4.1.3.14

Using a suitable drift and a soft hammer, drive pump drive shafts from bearings.

T-88140

WARNING

It is unsafe to strike hardened steel parts with anything other than a soft iron or non-ferrous hammer. When installing or removing such parts wear safety glasses with side shields and heavy gloves, etc., to reduce the possibility of injury.

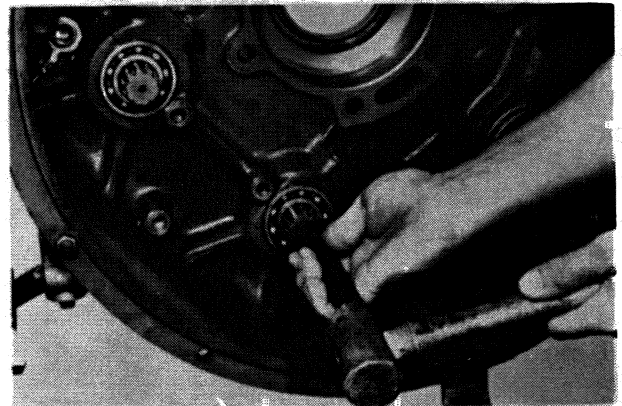

2.4.1.3.15

Drive bearings and spacers from housing.

T-88142

WARNING

It is unsafe to strike hardened steel parts with anything other than a soft iron or non-ferrous hammer. When installing or removing such parts wear safety glasses with side shields and heavy gloves, etc., to reduce the possibility of injury.

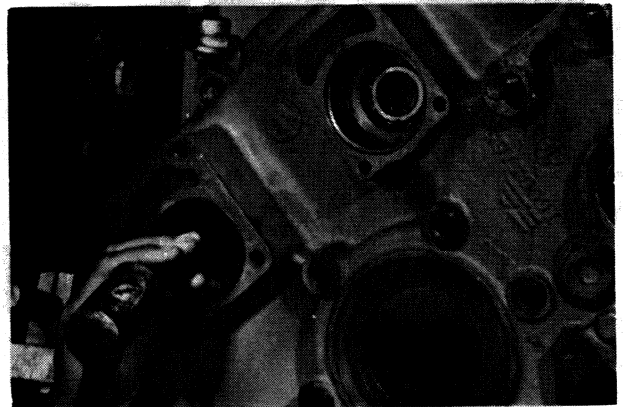

2.4.1.3.16

Remove equipment pump drive shaft retaining ring.

T-88144

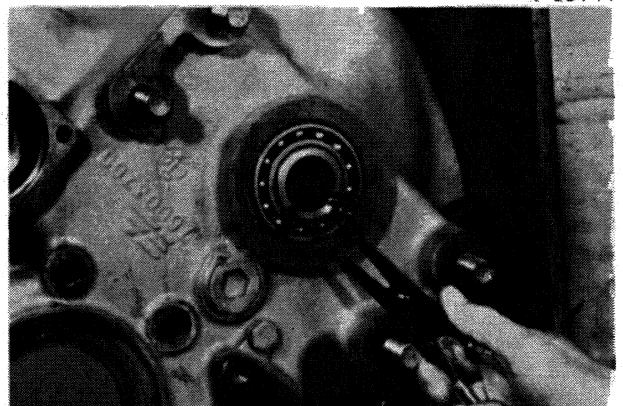

Study SAFETY RULES in the front of this manual thoroughly for the protection of machine and safety of personnel.

2.4 REPAIR PROCEDURES

2.4.2.1.13

Disconnect and tag the three lines from the top of the transmission control valve to the manipulator.

T-93637

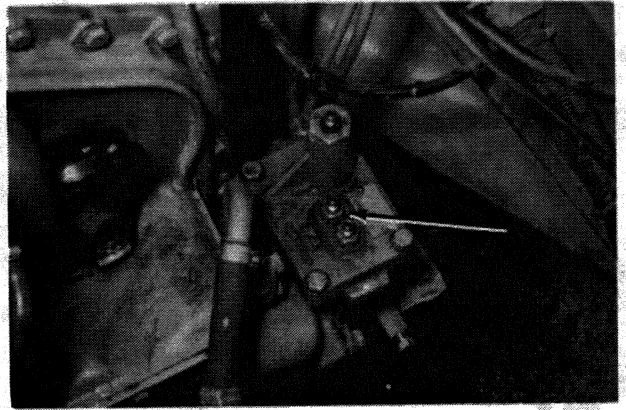

2.4.2.1.14

Disconnect and tag the four lines from the back of the transmission control valve. Two lead to the test panel, one to the manipulator, and one to the brake unlock valve.

T-93639

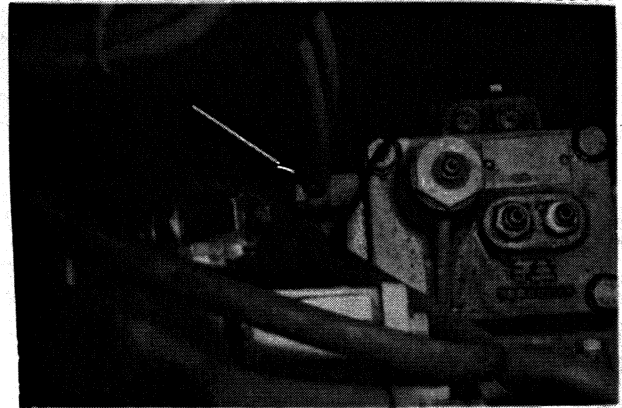

2.4.2.1.15

Remove access cover from transmission to the final drive.

T-93641

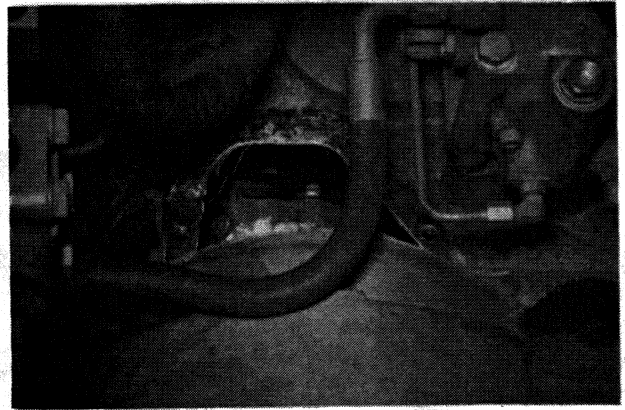

2.4.2.1.16

Support the transmission with a suitable hoist. Transmission weighs approximately 450 Kg (990 lbs).

T-93643



Study SAFETY RULES in the front of this manual thoroughly for the protection of machine and safety of personnel.

2.4 REPAIR PROCEDURES

2.4.2.3.33

Install three clamps (P/N 75291531) on high range clutch assembly.

T-88267

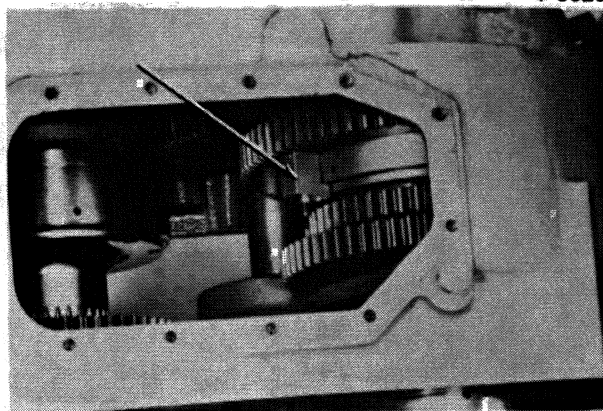

2.4.2.3.34

Remove intermediate range clutch shaft lock nut.

T-88264

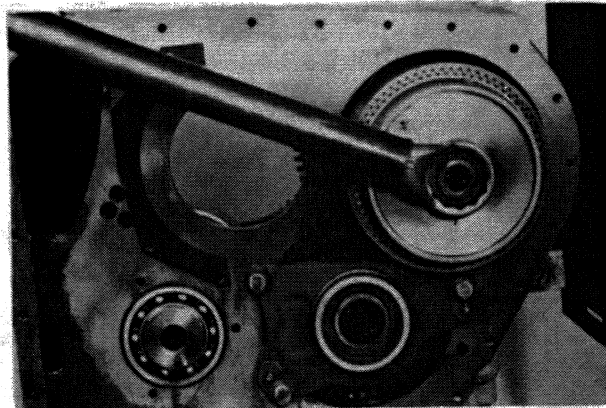

2.4.2.3.35

Remove intermediate range clutch piston.

T-88266

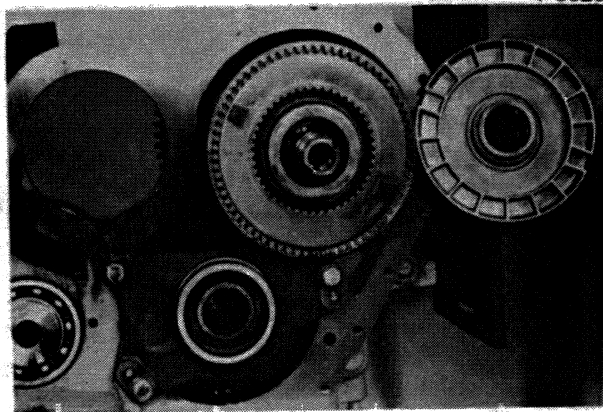

2.4.2.3.36

Remove intermediate range clutch pack and hub assembly.

T-88268

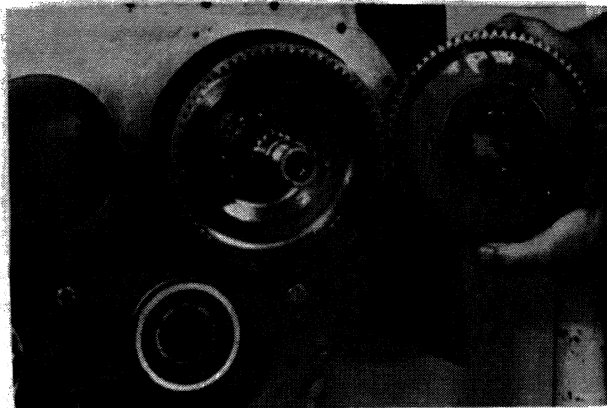

Study SAFETY RULES in the front of this manual thoroughly for the protection of machine and safety of personnel.

2.4 REPAIR PROCEDURES

2.4.2.3.60.6

Remove clutch pack from hub.

T-88299

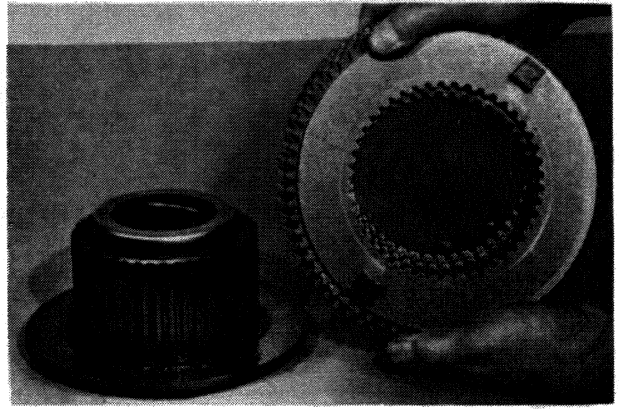

2.4.2.3.60.7

Check all clutch disc and steel plates for proper thickness; replace if not within specifications.

T-88325

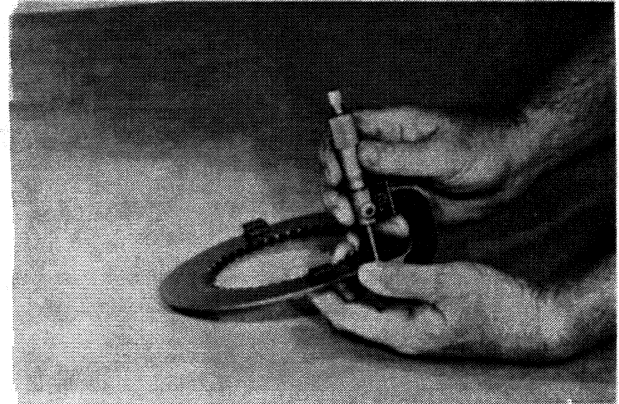

2.4.2.3.60.8

Using a long threaded capscrew, compress return spring.

T-88301

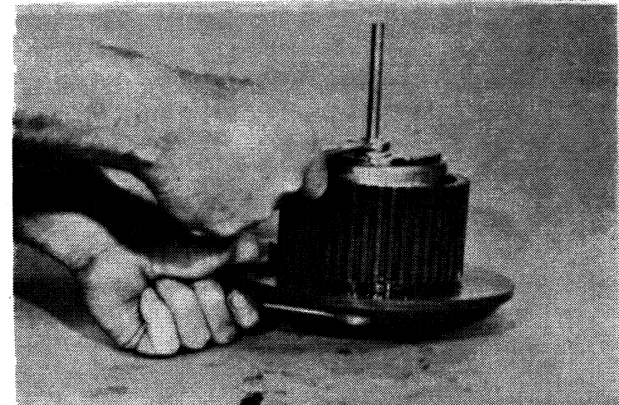

2.4.2.3.60.9

Remove snap ring.

T-88302

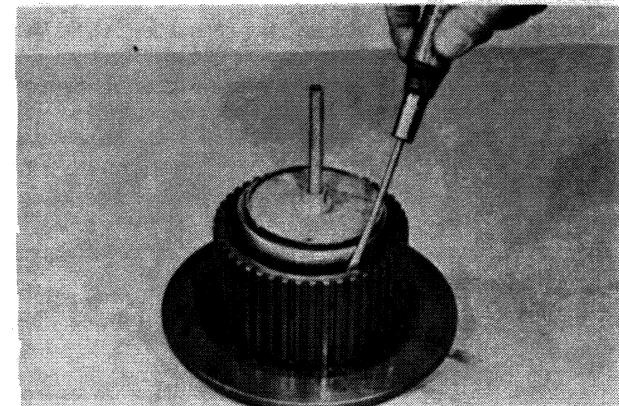

Study SAFETY RULES in the front of this manual thoroughly for the protection of machine and safety of personnel.

2.4 REPAIR PROCEDURES

2.4.3.1.4

Disassemble spool assembly.

T-88403

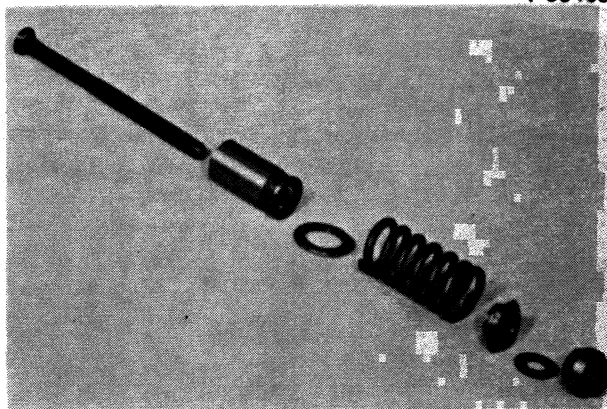

2.4.3.1.5

Check spring to insure it is within proper specifications.

2.4.3.1.6

Reassemble spool assembly as shown in Fig. 2.6.8. Do not tighten adjusting ring at this time.

2.4.3.1.7

Remove valve seat from valve body.

T-88162



Study SAFETY RULES in the front of this manual thoroughly for the protection of machine and safety of personnel.

2.4 REPAIR PROCEDURES

2.4.3.3.10

Turn selector assembly upside down and remove connections.

T-86695

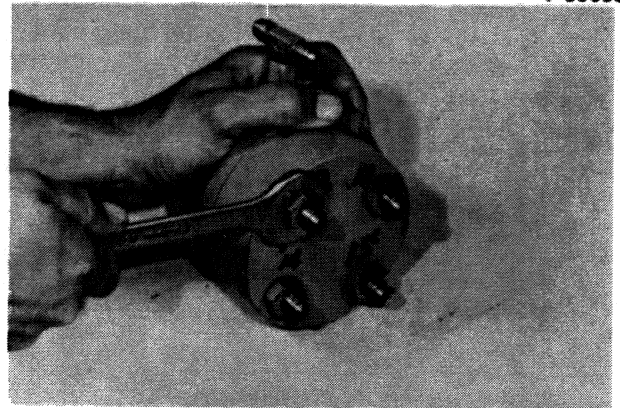

2.4.3.3.11

Lift off lower cover, springs and plunger seats.

T-86694



2.4.3.3.12

Check all components to insure they are within specifications.

2.4.3.3.13

Install new o-rings in counter bores of valve body.

T-86699

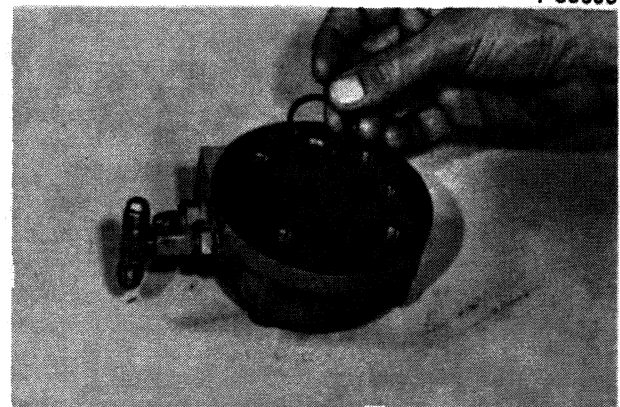

Study SAFETY RULES in the front of this manual thoroughly for the protection of machine and safety of personnel.

2.6 SPECIFICATIONS

	DESCRIPTION	daNm	lbs.ft.
1.	Front bearing retainer capscrews	4.1 - 4.9	30.2 36
2.	Shaft hub retainer capscrews	4.1 - 4.9	30.2 - 36
3.	Drive shaft flange screws	10.8 - 11.75	79.6 - 86.6
4.	Converter housing capscrews	6.8 - 7.4	50.2 - 54.6
5.	Rear impeller retaining capscrews	2.3 - 2.8	16.9 - 20.6
6.	Stator retaining capscrews	3.4 - 3.9	25.1 - 28.8
7.	Pump drive gear retaining capscrews	4.1 - 4.9	30.2 - 36.1
8.	Steering pump mounting capscrews	1.2 - 1.4	8.8 - 10.3
9.	Pressure regulating valve mounting capscrews	6.8 - 7.4	50.2 - 54.6
10.	Rear bearing support retaining capscrews	8.0 - 8.8	59.0 64.9
11.	Rear output flange retainer capscrews	3.5 - 4.0	25.8 - 29.5
12.	Oil baffle plate mounting capscrews	3.0 - 3.3	22.1 24.3
13.	Oil baffle support mounting capscrews	6.8 - 7.4	50.2 - 54.6
	Implement pump driven gear capscrews	7.5 8.3	55.3 - 61.2
	Steering & brake pump mounting capscrews	1.2 1.4	8.8 - 10.3
	Transmission Torque Converter pump capscrews	6.8 7.4	50.2 54.6
	Pump drive hub nut	2.1 2.3	15.4 16.9
	Hydraulic pump mounting capscrews		

Study SAFETY RULES in the front of this manual thoroughly for the protection of machine and safety of personnel.

2.6 SPECIFICATIONS

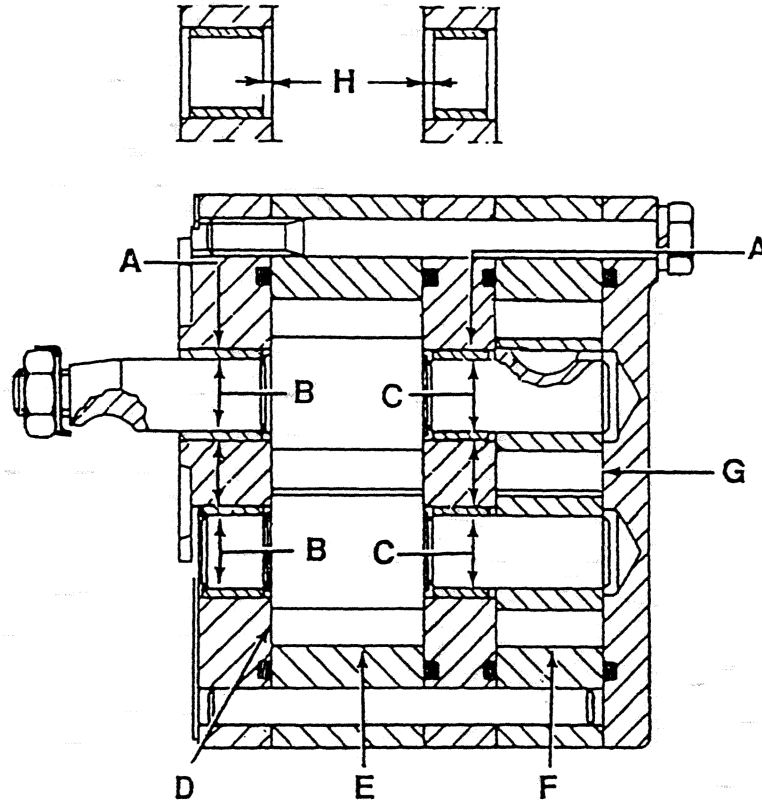

T-85788

Study **SAFETY RULES** in the front of this manual thoroughly for the protection of machine and safety of personnel.

3.4 REPAIR PROCEDURES

3.4.1 DISASSEMBLY

3.4.1.1

Remove the track as described in *UNDERCARRIAGE* section .



WARNING

Do not work under or near an unblocked or unsupported linkage, parts or machine.

Lift and handle all heavy parts with a lifting device of proper capacity. Be sure parts are supported by proper slings and hooks. Use lifting eyes if provided. Watch out for people in the vicinity.

Always turn the master switch to the off position before cleaning, repairing, servicing or parking the machine to prevent injury.

3.4.1.2

Drain fluid from final drive housing.

T-93230

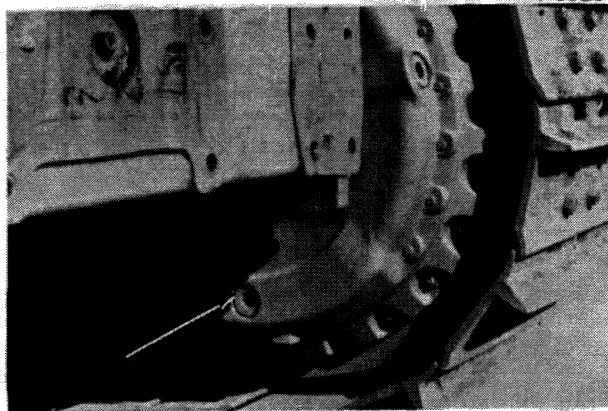

3.4.1.3

Remove capscrews attaching outboard bearing cap cover.

T-87751

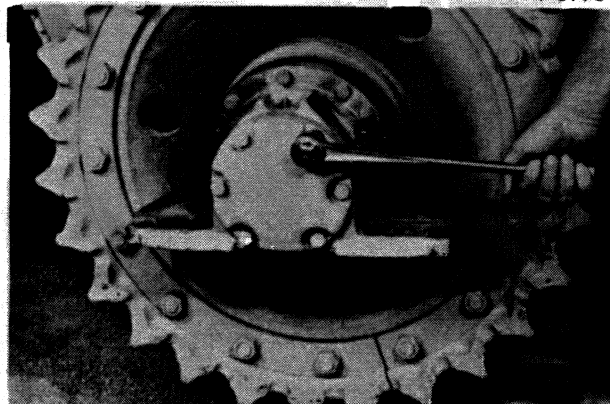

Study **SAFETY RULES** in the front of this manual thoroughly for the protection of machine and safety of personnel.

3.4 REPAIR PROCEDURES

3.4.1.40

Remove the inboard tapered roller bearing race using a suitable press, or a suitable puller if the suspension shaft has not been removed.

M3109

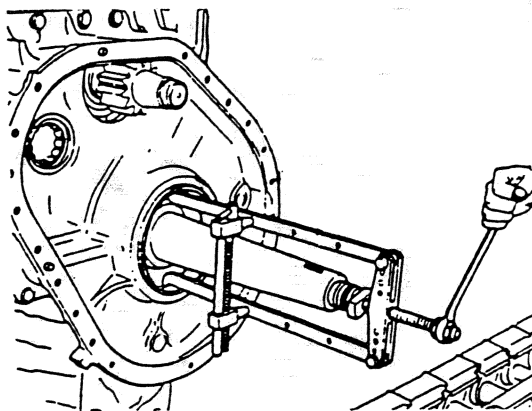

3.4.1.41

Straighten lock plate for suspension shaft nut.

T-87801



WARNING

It is unsafe to strike hardened steel parts with anything other than a soft iron or non-ferrous hammer. When installing or removing such parts wear safety glasses with side shields and heavy gloves, etc., to reduce the possibility of injury.

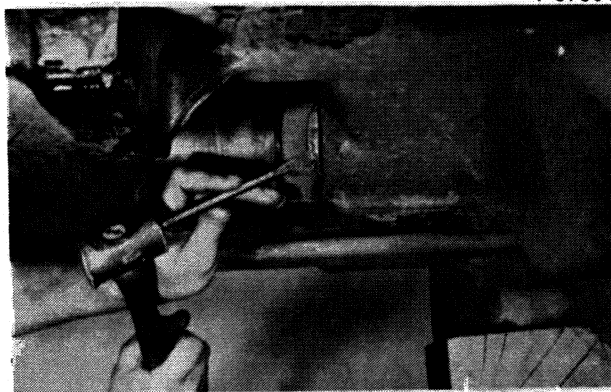

T-87803

3.4.1 42

Loosen nut from under housing approximately 6.35mm (1/4 in.) using spanner (75292961) and torque wrench (75291286).

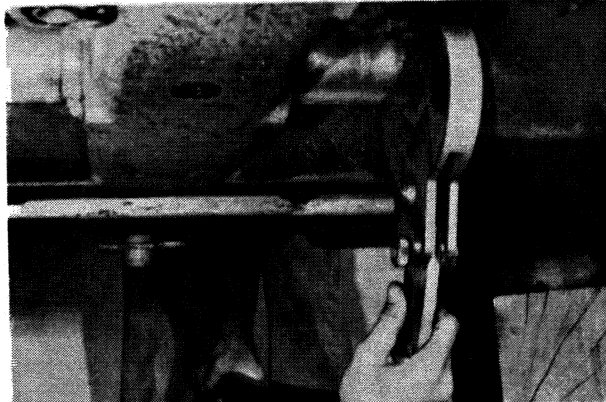

T-87806

3.4.1 43

Assemble puller and ram (75295015) on the suspension shaft as shown and pull the shaft using the following tools:

1. 75295015 Ram & Center Screw
2. 75300602 Shaft Adapter
3. 75297571 Spacer
4. 75297542 Tube

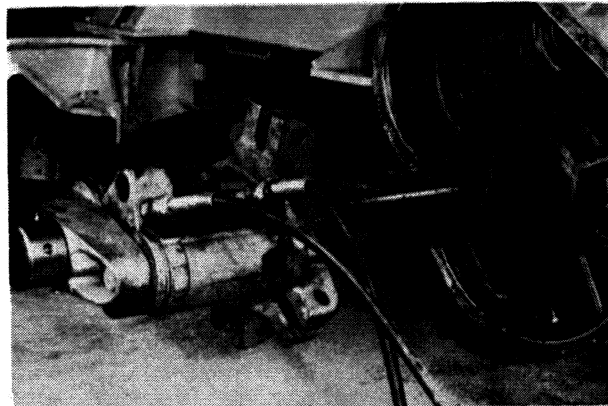

Study SAFETY RULES in the front of this manual thoroughly for the protection of machine and safety of personnel.

3.4 REPAIR PROCEDURES

3.4.11 ASSEMBLY

3.4.11.1

If the inboard bearing case for the drive gear was removed, install new bearing case and O-ring. Secure bearing case with screw and lockwasher.

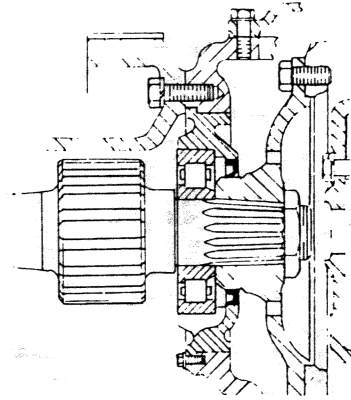

3.4.11.2

If the suspension shaft was removed separate from the intermediate housing, set the suspension shaft in the housing and align the keyway of the shaft with the dimple in the housing bore. Press the shaft into the housing with a force of 29,500 daN (66,317 lbs.).

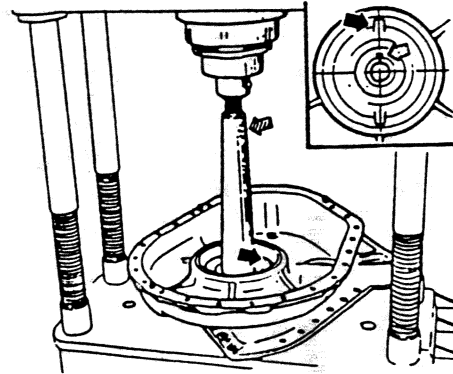

7233

3.4.11.3

Coat the mating surfaces of the intermediate housing and steering clutch housing with liquid gasket (70699262) and install the intermediate housing using the two guide studs previously installed.



WARNING

Lift and handle all heavy parts with a lifting device of proper capacity. Be sure parts are supported by proper slings and hooks. Use lifting eyes if provided. Watch out for people in the vicinity.

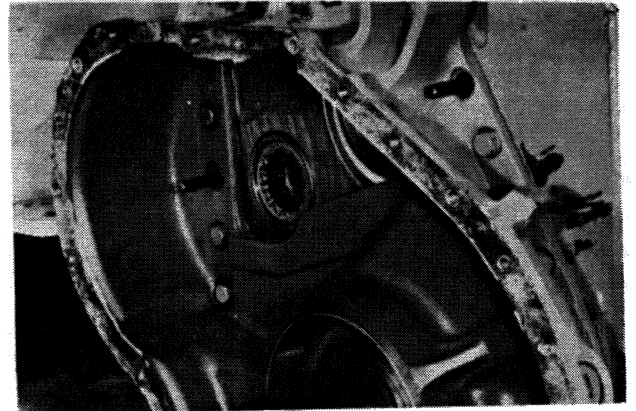

T-87881

3.4.11.4

Tighten the suspension shaft nut to specified torque.

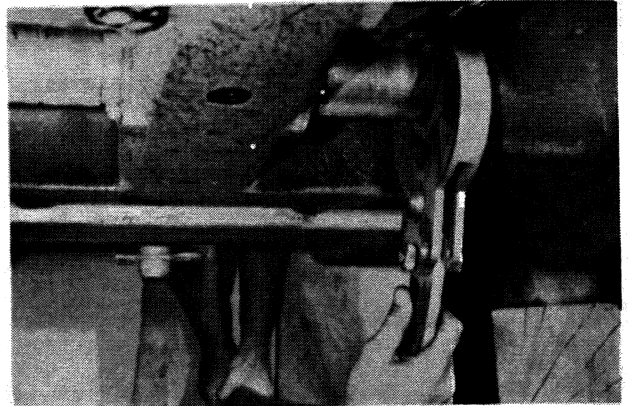

T-87804

Study SAFETY RULES in the front of this manual thoroughly for the protection of machine and safety of personnel.

3.4 REPAIR PROCEDURES

M3040

3.4.12 PRELOAD ADJUSTMENT OF SPROCKET BEARINGS

3.4.12.1

Install the outboard bearing cage (less the shims) onto the shaft and retain it with the bearing cap washer, lock plate and nut. Tighten nut to specified torque.



WARNING

Lift and handle all heavy parts with a lifting device of proper capacity. Be sure parts are supported by proper slings and hooks. Use lifting eyes if provided. Watch out for people in the vicinity.

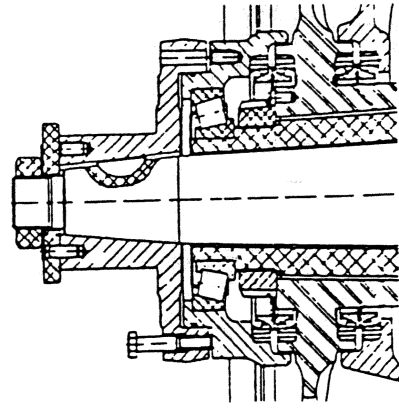

3.4.12.2

Remove the screws and lockwashers retaining the cage halves.

3.4.12.3

Take three retaining screws and flatten the threaded end using a grinding wheel or file.



WARNING

Wear proper protective equipment such as safety goggles or safety glasses with side shields, hard hat, safety shoes and heavy gloves, when metal or other particles are apt to fly or fall.

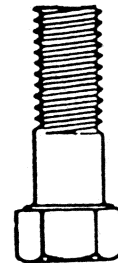

3.4.12.4

Remove the three corks and run a tap through the holes and on the screws to clean the threads. Lubricate the three screws with engine oil and screw them into the pusher screw holes.

T-87890

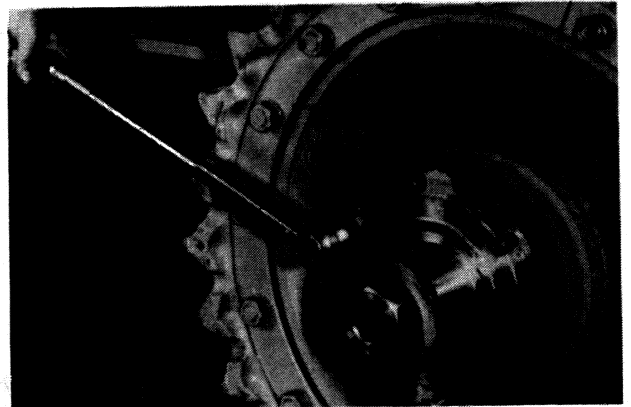

Study **SAFETY RULES** in the front of this manual thoroughly for the protection of machine and safety of personnel.

3.6 SPECIFICATIONS

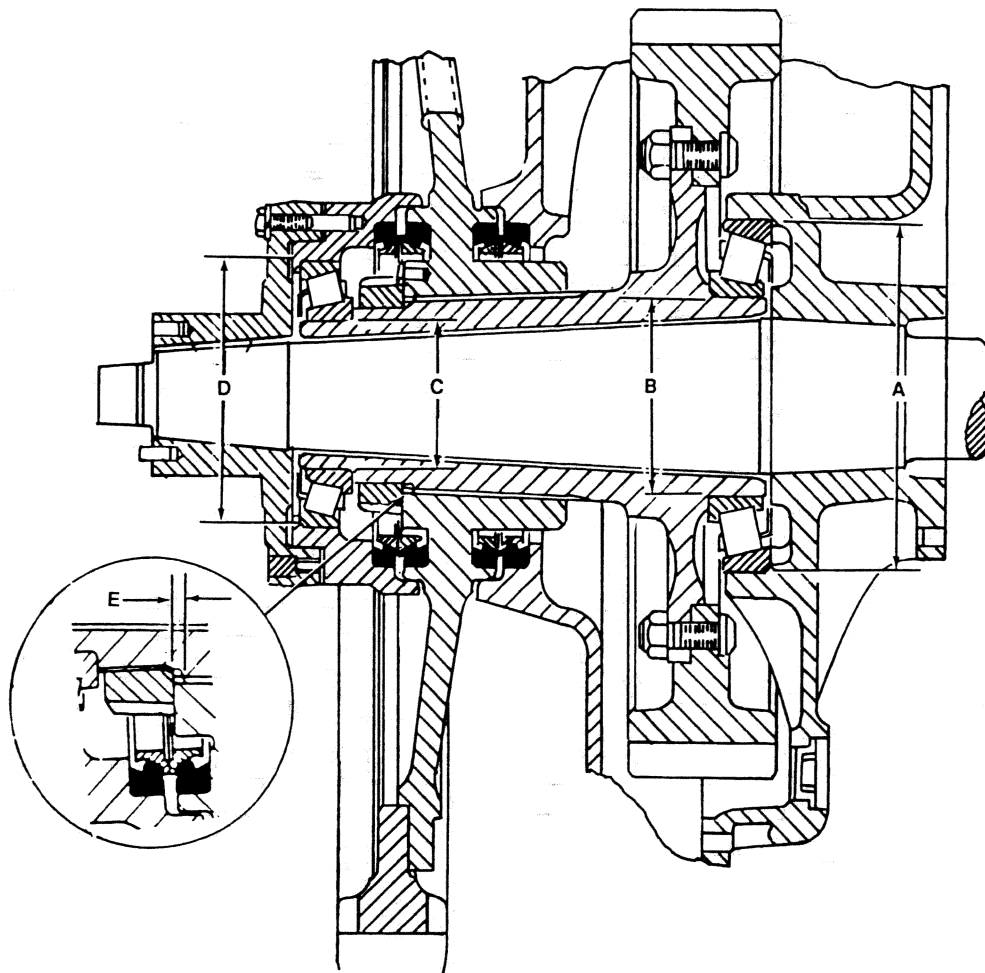

T-85776

3.6.3.4 DRIVEN GEAR HUB

	millimeters		inches	
A. Bore in intermediate housing for inner taper roller bearing Inner taper roller bearing O.D. Interference fit	239.887	239.933	9.4444	9.4462
	239.970	240.000	9.4476	9.4488
	.037 tight	113 tight	.0014 tight	.0044 tight
B. Inner taper roller bearing I.D. Driven gear hub O.D. for inner taper roller bearing Interference fit	169.975	170.000	6.6919	6.6929
	170.043	170.068	6.6946	6.6956
	.043 tight	.093 tight	.0017 tight	.0037 tight
C. Driven gear hub O.D. for outer taper roller bearing Outer taper roller bearing I.D. Interference fit	110.023	110.045	4.3316	4.3325
	110.000	110.025	4.3307	4.3317
	.002 tight	.045 tight	.0001 tight	.0018 tight
D. Outer taper roller bearing O.D. Bearing cage I.D. for outer taper roller bearing Interference fit	169.975	170.000	6.6919	6.6929
	169.907	169.947	6.6892	6.6908
	.028 tight	.093 tight	.0011 tight	.0037 tight
E. Distance after installation	3.5	5.5	0.13	0.21

Study SAFETY RULES in the front of this manual thoroughly for the protection of machine and safety of personnel.

4.2 TROUBLESHOOTING

SYMPTOM	PROBABLE CAUSE	TOOLS REQUIRED	TEST	SOLUTION
Both brakes do not apply when in a direction	Low steering/brake relief pressure	75294308	Check pressure at clutches & brakes	If pressure rises somewhat but does not meet specification, raise relief pressure
	Servo valve stuck	75294308	Check pressure at clutches & brakes	If pressure does not rise free servo valve
	Mis-adjustment of the bands			Adjust brakes
Brakes do not release when shifting into a direction	Transmission neutral lock engaged	75294308	Check pressure at back end of the brake cylinder	If pressure is 0 check valve positioning
	Brake center pedal linkage causes spool malfunction			Check linkage
	Transmission pilot piston stuck	75294308	Check pressure at back end of brake cylinder	If pressure is 0 check valve positioning
	Low transmission apply pressure	75294308	Check pressure at transmission filter or at main pressure regulating valve	If low correct transmission problem
	Modulating piston stuck			Free modulating piston
Clutch does not modulate	Manipulator piston does not modulate	75294308	Check pressure at manipulator	If pressure does not modulate free modulator piston or replace spring

Study SAFETY RULES in the front of this manual thoroughly for the protection of machine and safety of personnel.

4.4 REPAIR PROCEDURES

4.4.1 4.8
Remove pressure plate.

T-88362

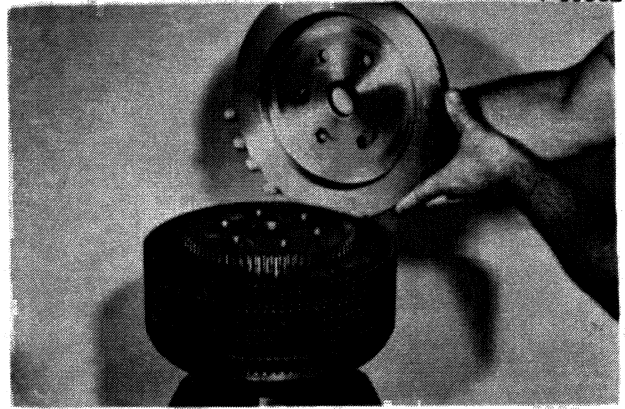

4.4.1 4.9
Remove clutch stack.

T-88363

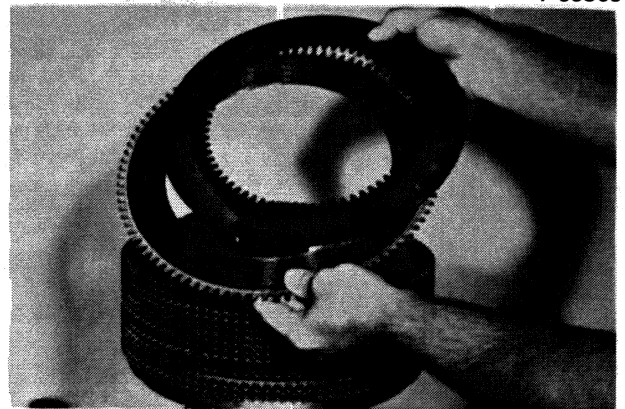

4.4.1.4.10
Remove drive disc drum.

T-88365

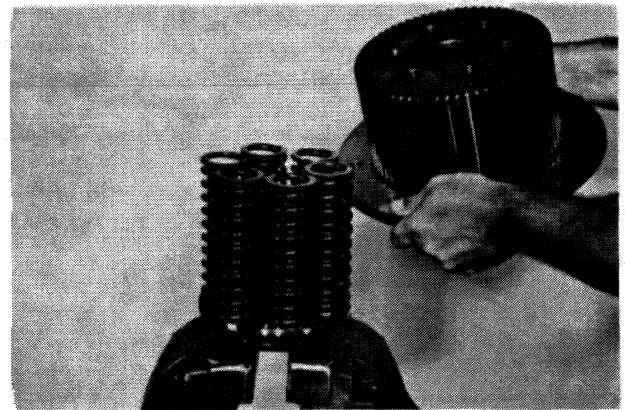

4.4.1.4.11
Remove outer springs.

T-88366

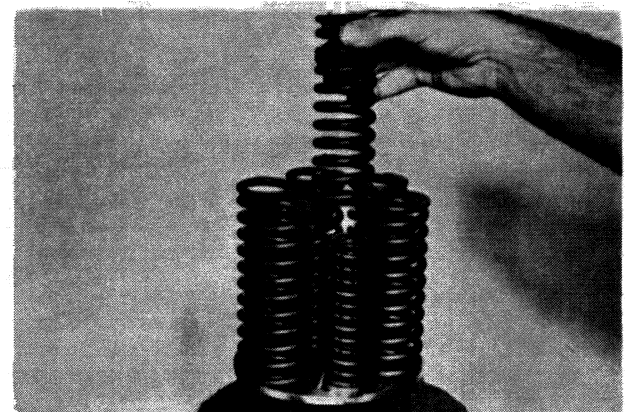

Study SAFETY RULES in the front of this manual thoroughly for the protection of machine and safety of personnel.

4.4 REPAIR PROCEDURES

4.4.2.3.6

Install puller (75291578) to the drive hub. Tighten center capscrew until the hub is forced from the tapered spline.

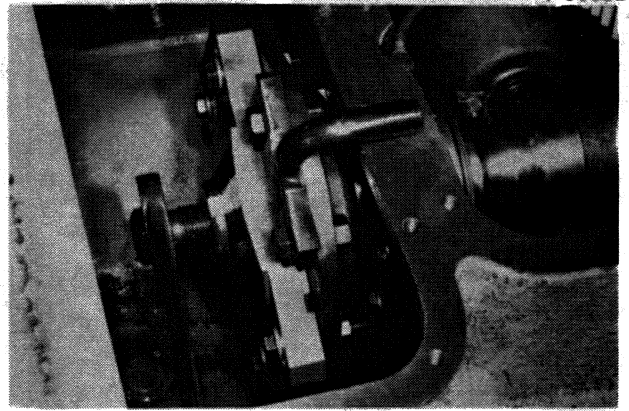

T-86932

4.4.2.3.7

Using a mirror, note the location of the marked splines. If not marked, then mark mating splines. Remove drive hub. Repeat same procedure for other side.

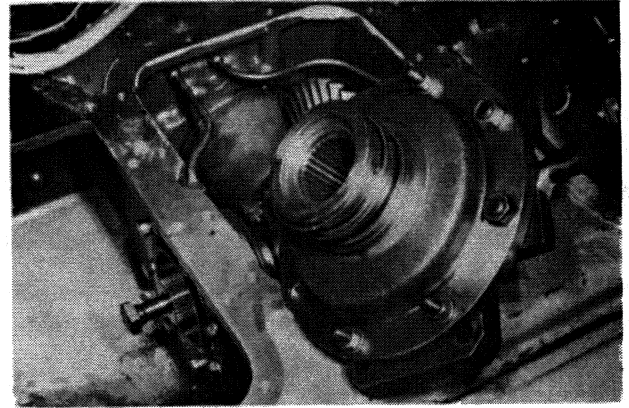

T-86933

4.4.2.3.8

Disconnect clutch disengagement oil lines at bearing cage.

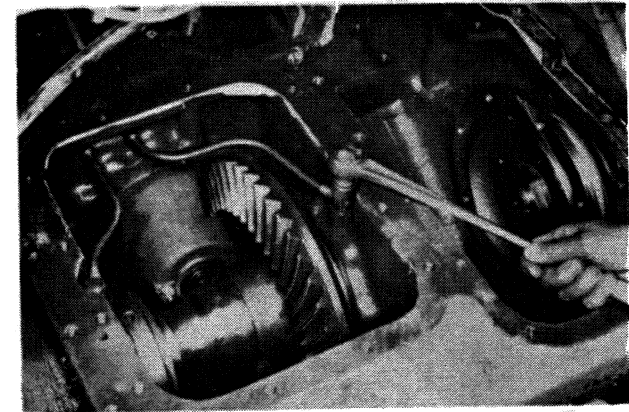

T-86934

4.4.2.3.9

Install a screw into the threaded dowel that retains the clutch disengagement oil lines at front of housing directly under where steering valve mounts and pry up on screw to remove dowel.

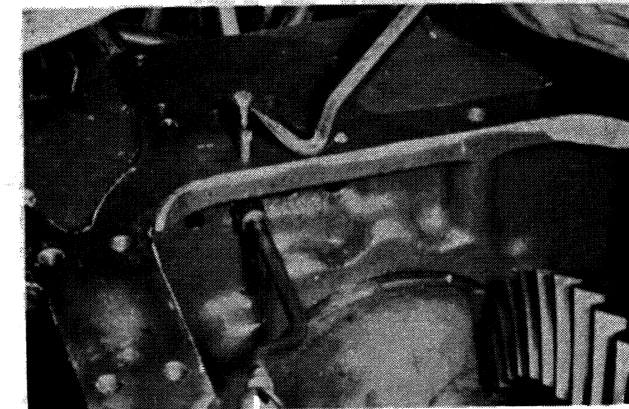

T-86938

Study **SAFETY RULES** in the front of this manual thoroughly for the protection of machine and safety of personnel.

4.4 REPAIR PROCEDURES

4.4.2.8.7
Install pinion in pinion housing.

T-86993

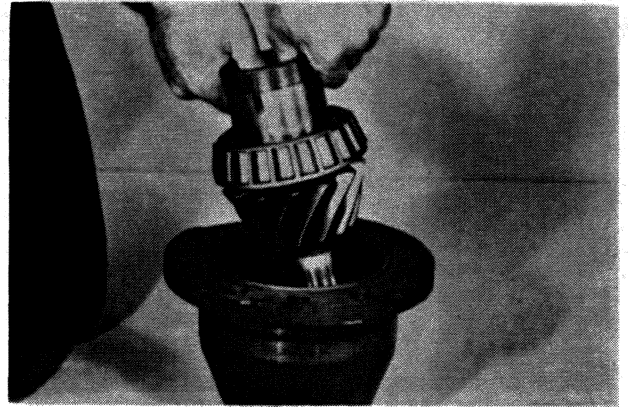

4.4.2.8.8
Install inner spacer.

T-86994

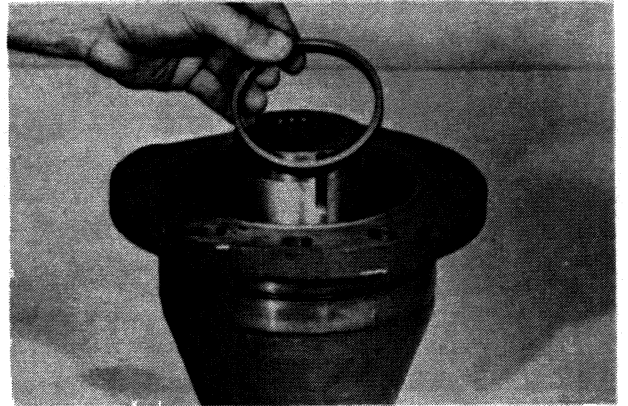

4.4.2.8.9
Install outer race. Make sure bearing markings coincide with both cup and cone. If the set is mixed, bearing may fail prematurely.

T-86995

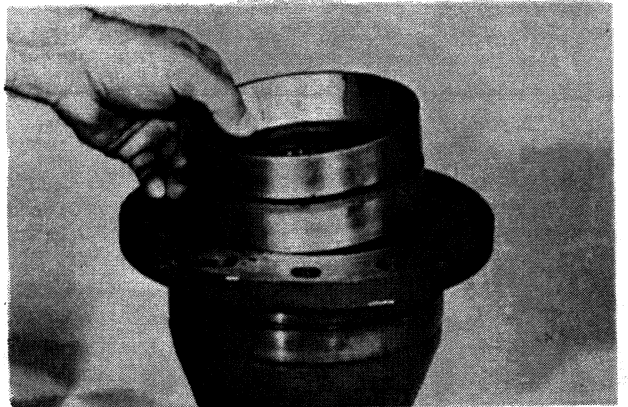

4.4.2.8.10
Heat and install top bearing.

T-86997

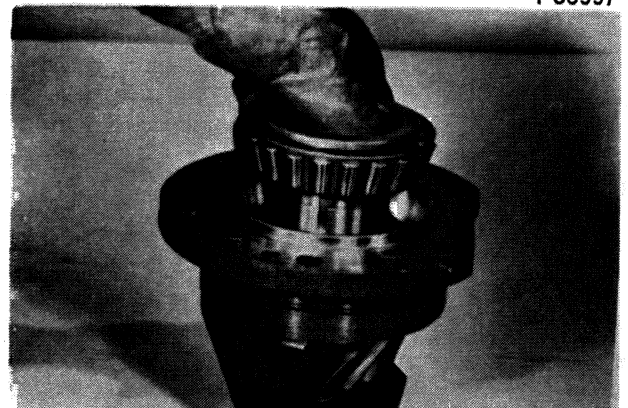

Study **SAFETY RULES** in the front of this manual thoroughly for the protection of machine and safety of personnel.

4.4 REPAIR PROCEDURES

4.4.3.2.5

Remove the elbow only if replacement is necessary.

T-89431

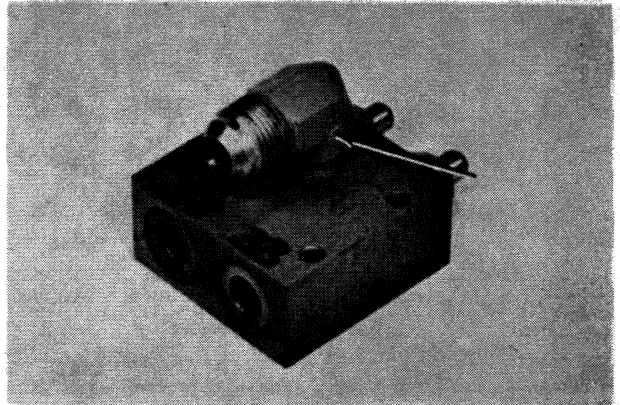

4.4.3.2.6

Remove the plug only if replacement is necessary.

T-89432

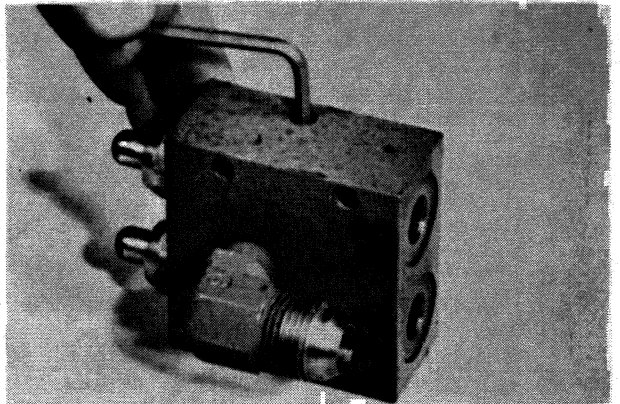

4.4.3.2.7

Remove the guides and o-rings.

T-89434

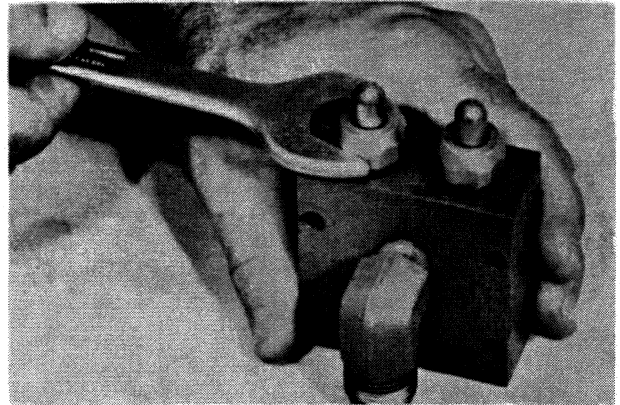

4.4.3.2.8

Remove the two o-rings from each guide.

T-89433

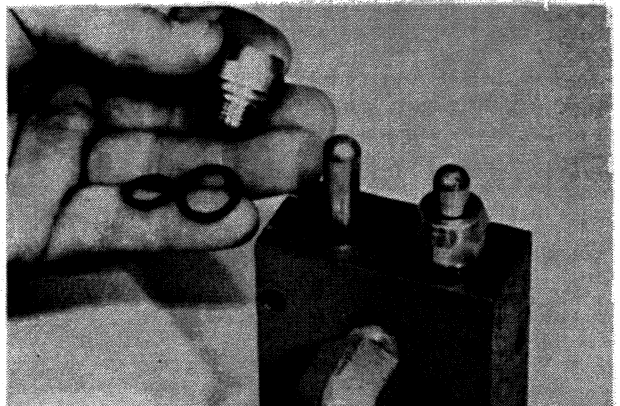

Study **SAFETY RULES** in the front of this manual thoroughly for the protection of machine and safety of personnel.

4.4 REPAIR PROCEDURES

4.4.4.3 CLEANING and INSPECTION

4.4.4.3.1

Inspect all parts for signs of wear due to scoring, pitting, scaling or scratches.

4.4.4.3.2

Replace all snap rings, o-rings and seals.

4.4.4.3.3

Inspect that spools and pistons slide freely in their respective bores.

4.4.4.3.4

Lubricate all parts with clean hydraulic oil prior to reassembly.

Study **SAFETY RULES** in the front of this manual thoroughly for the protection of machine and safety of personnel.

4.4 REPAIR PROCEDURES

4.4.6 BRAKE PISTON HOUSING

T-87044

4.4.6.1 DISASSEMBLY

4.4.6.1.1

Back the brake release screw to remove most of the spring tension.

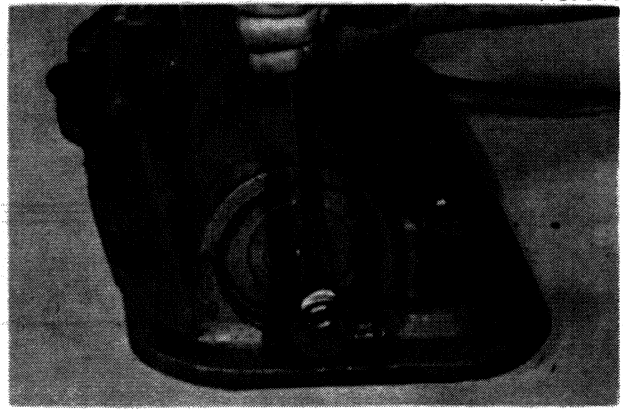

4.4.6.1.2

Remove the front cover from the brake piston housing.

T-87046

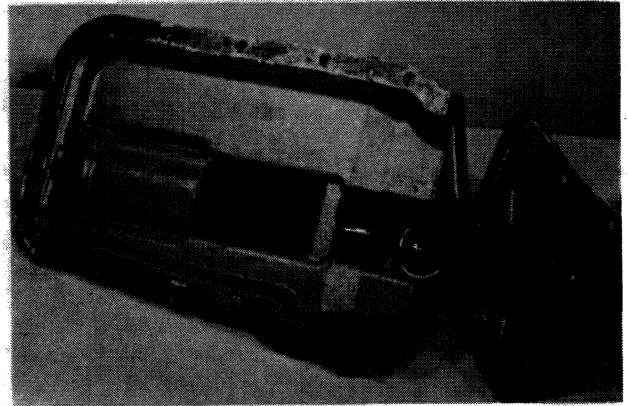

4.4.6.1.3

Place the brake piston housing in a shop press and compress the piston retainer. Remove the snap ring from the housing. Release the applied load on the piston retainer. The spring will force the piston and retainer approximately 25mm (1 inch) out of the housing.

T-87047

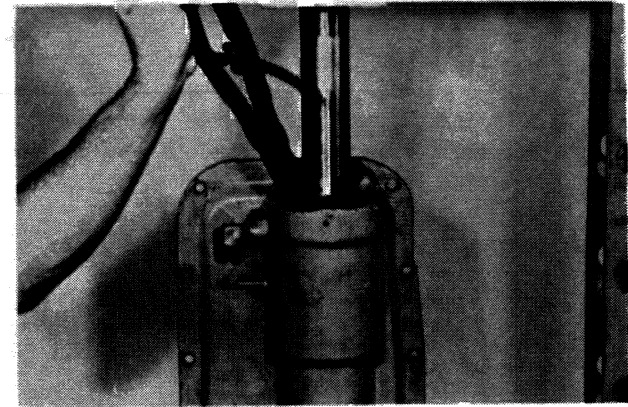

WARNING

Brake valves have a heavy spring compressed inside them. Always follow procedures recommended in steering clutches and brakes service manual when assembling or disassembling these valves.

T-87048

4.4.6.1.4

The brake piston's spring, release piston, retainer and snap ring are removed from the end of the housing.

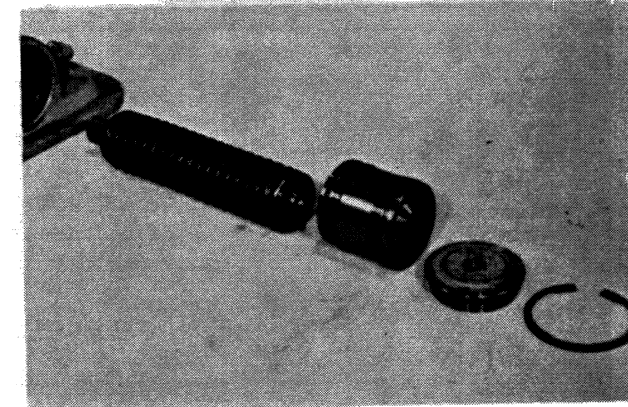

Study SAFETY RULES in the front of this manual thoroughly for the protection of machine and safety of personnel.

4.4 REPAIR PROCEDURES

T-89571

4.4.7.3.12
Install the wedge to the brake linkage.

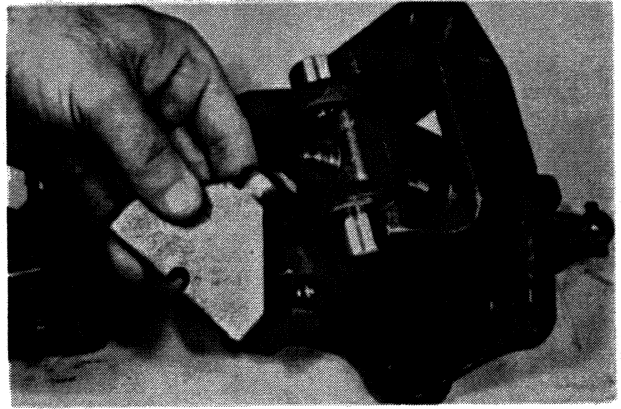

Study **SAFETY RULES** in the front of this manual thoroughly for the protection of machine and safety of personnel.

4.6 SPECIFICATIONS

4.6.3 STEERING FILTER

GENERAL

Pump intake filter Full flow, metallic element with magnetic rod

Bevel gear housing oil return filter By-pass type, spin-on

Filter mesh size 15 microns

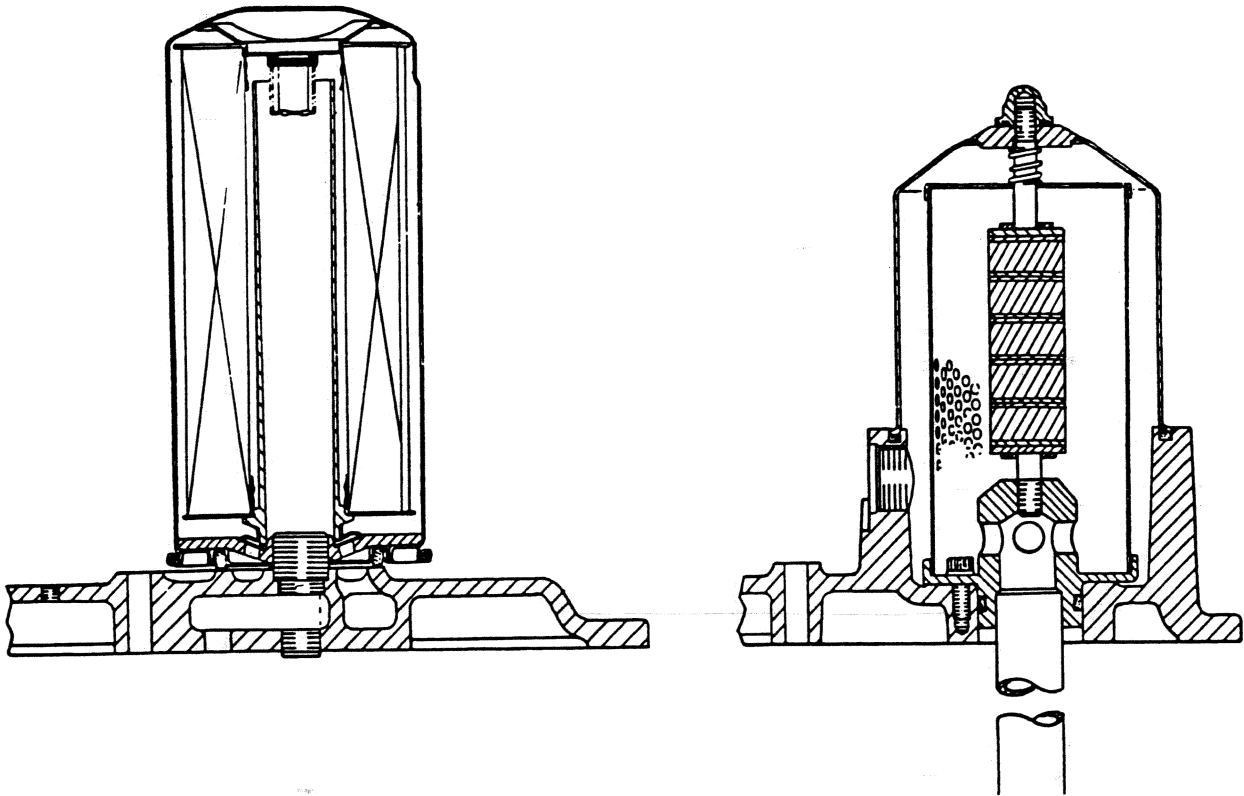

T-85791

Study **SAFETY RULES** in the front of this manual thoroughly for the protection of machine and safety of personnel.

4.6 SPECIFICATIONS

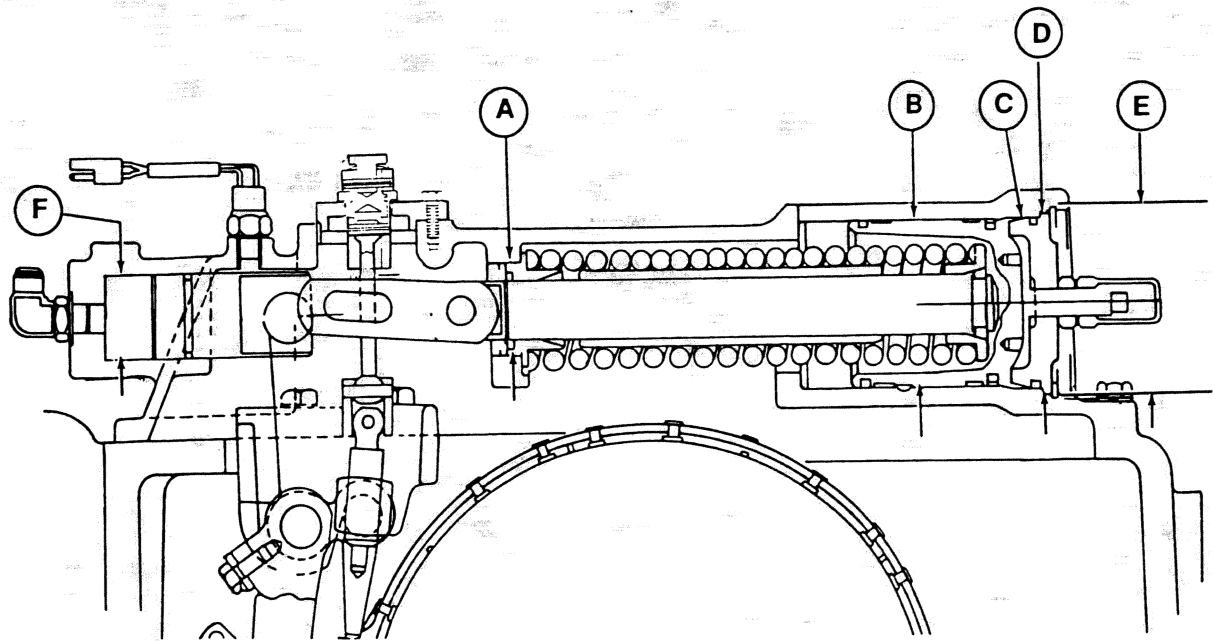

T-85705

Study **SAFETY RULES** in the front of this manual thoroughly for the protection of machine and safety of personnel.

SECTION 5

HYDRAULICS

TABLE OF CONTENTS

TOPIC	TITLE	PAGE
5.1	GENERAL DESCRIPTION.....	5-1
5.2	TROUBLESHOOTING	5-5
5.3	TESTING.....	5-9
5.4	REPAIR PROCEDURES.....	5-15
5.4.1	Hydraulic/Fuel Tank	5-15
5.4.2	Hydraulic Pump	5-20
5.4.3	Hydraulic Control Valve	5-23
5.4.4	Hydraulic Controls Adjustment.....	5-31
5.4.5	Hydraulic Cylinders	5-33
5.4.6	Dozer Installation	5-42
5.5	TOOLS.....	5-46
5.6	SPECIFICATIONS	5-47
5.6.1	Hydraulic Tank.....	5-47
5.6.2	Control Valve.....	5-48
5.6.3	Hydraulic Pump	5-55
5.6.4	Dozer Lift Cylinder	5-56
5.6.5	Dozer Lift Cylinder Trunnion.....	5-57
5.6.6	Dozer Tilt Cylinder (Single cylinder application)	5-58
5.6.7	Dozer Tilt Cylinder (Two cylinder application).....	5-59
5.6.8	Pilot Valve (Angle Dozer w/hydraulic tilt)	5-60
5.6.9	Ripper Cylinder.....	5-61
5.6.10	Dozer Push beams & Braces	5-62
5.6.11	C-Frame & Struts	5-63
5.6.12	Ripper Linkage	5-64

Study SAFETY RULES in the front of this manual thoroughly for the protection of machine and safety of personnel.

CLICK HERE TO **DOWNLOAD** THE COMPLETE MANUAL

- Thank you very much for reading the preview of the manual.
- You can download the complete manual from: www.heydownloads.com by clicking the link below



- Please note: If there is no response to CLICKING the link, please download this PDF first and then click on it.

CLICK HERE TO **DOWNLOAD** THE COMPLETE MANUAL

5.3 TESTING

5.3 TESTING

5.3.1 USE OF THE FLOW METER

Use of the flow meter (FA P/N 75300836) will aid in isolating a problem within the hydraulic system. To prevent back-pressure, the meter return line must be slightly larger than inlet line. Return line leads to tank filler opening (screen removed) and should extend into tank far enough to be well submerged.

The line leading to the tank will tend to "jump out" and must be held firmly while testing. As pressure is applied with meter load valve, this tendency will increase but should be manageable. Be certain all test hoses are of high pressure type that will withstand a minimum 208 bar (3000 psi).

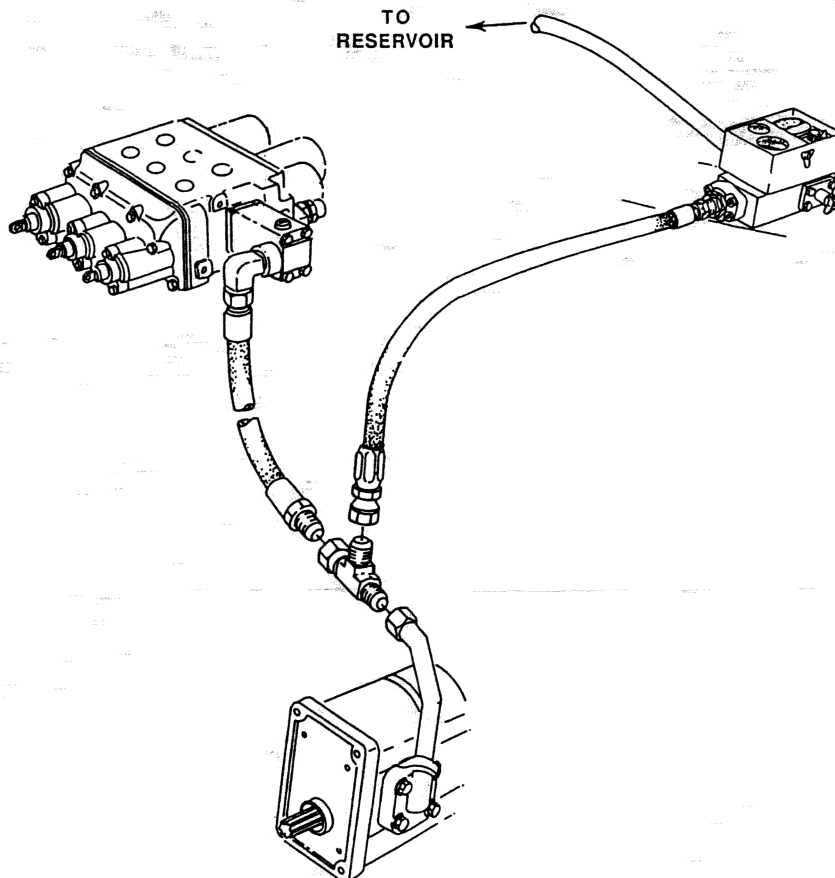

T-100481

Study **SAFETY RULES** in the front of this manual thoroughly for the protection of machine and safety of personnel.

5.4 REPAIR PROCEDURES

T-93716

5.4.1.2.6

Remove the suction filter cartridge from the tank. Wash the filter using a good commercial solvent.



DANGER

Never use gasoline solvent or other flammable fluids to clean element. Use authorized commercial, non-flammable, non-toxic solvents.

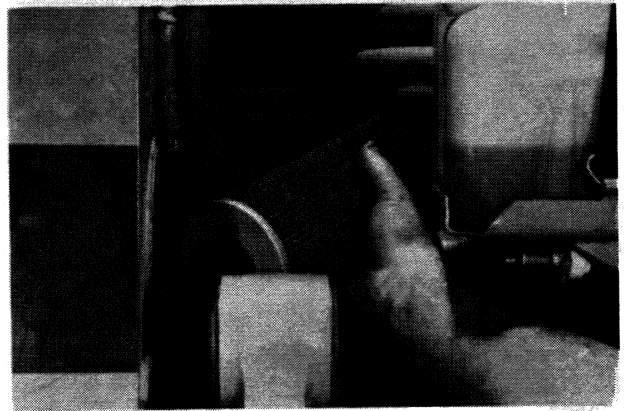

5.4.1.3 INSTALLATION

5.4.1.3.1

Installation of the Hydraulic/Fuel Tank is reverse procedure of removal.

Study **SAFETY RULES** in the front of this manual thoroughly for the protection of machine and safety of personnel.

5.4 REPAIR PROCEDURES

5.4.3.3.14

Mark the location of the valves within the valve block.
Remove the circuit relief valves from the valve block.

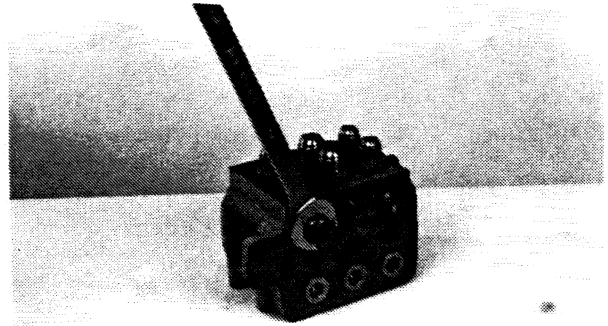

5.4.3.3.15

Remove the ripper and dozer check valves and the tilt circuit flow control valve from the valve block.

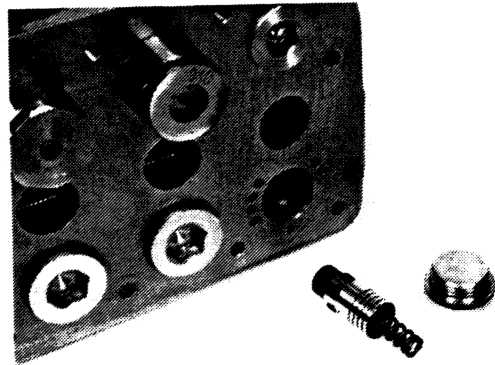

5.4.3.3.16

Disassembly of the dozer circuit relief valve can be done by using two opposing wrenches. Items within the valve are: poppet, stem, springs and shims. Add or remove shims as needed to set the pressure of the valve.

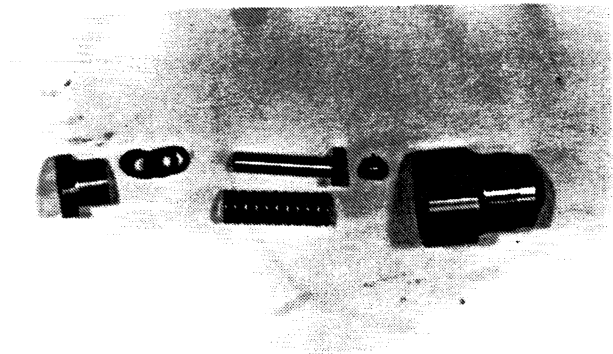

5.4.3.3.17

The ripper circuit relief valve is disassembled by placing the valve between two slotted nuts or use tools 75290561 and 75290562. Place one of the tools in a vise and loosen the valve with the other.

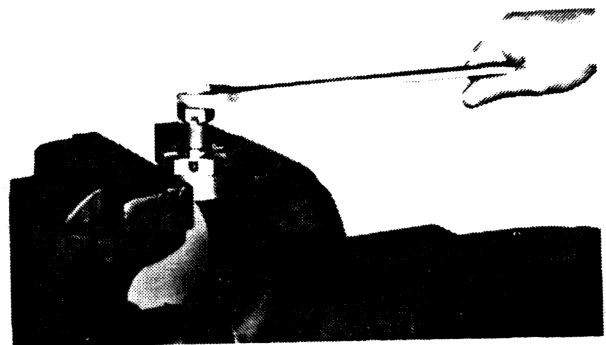

Study SAFETY RULES in the front of this manual thoroughly for the protection of machine and safety of personnel.

5.4 REPAIR PROCEDURES

5.4.5.7.2

Quick drop valve components are as shown, two end covers, body, check ball, seat, piston regulator and spring. Valve piston and housing are matched by the manufacturer and are not serviced separately.

T-93706

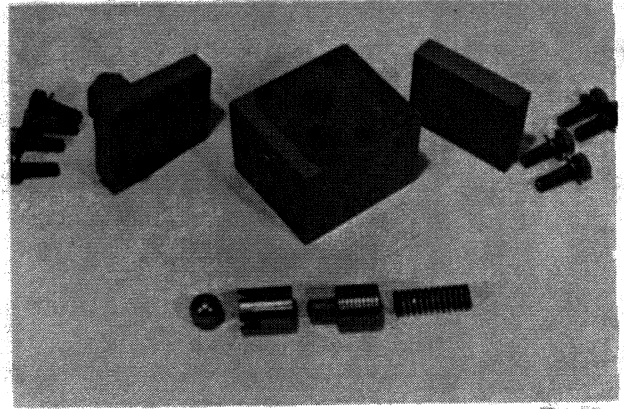

5.4.5.7.3

Unscrew the cylinder head from the dozer and ripper cylinder tube using wrench tool 75300478. On the tilt cylinder, remove the capscrews attaching the head to the tube.

T-88810

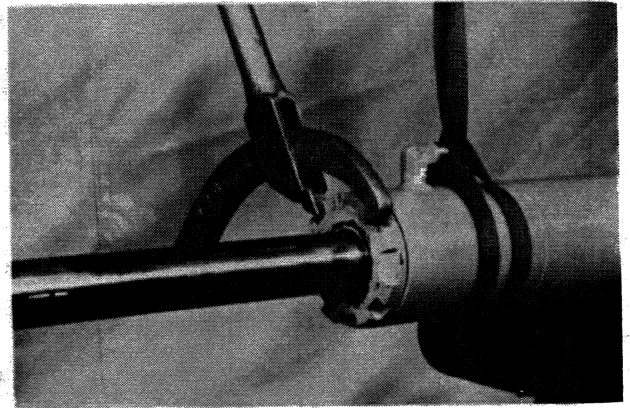

5.4.5.7.4

Pull the cylinder rod from the tube.

T-88811

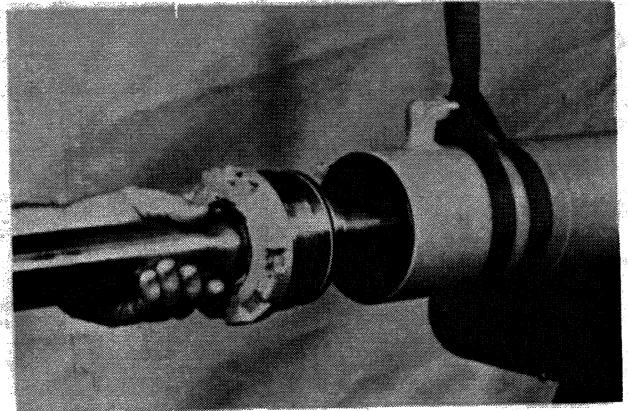

5.4.5.7.5

Place the cylinder rod (pin end) in a vise and support the rod with a suitable lifting device. Remove the piston retaining nut from the rod.

T-93713

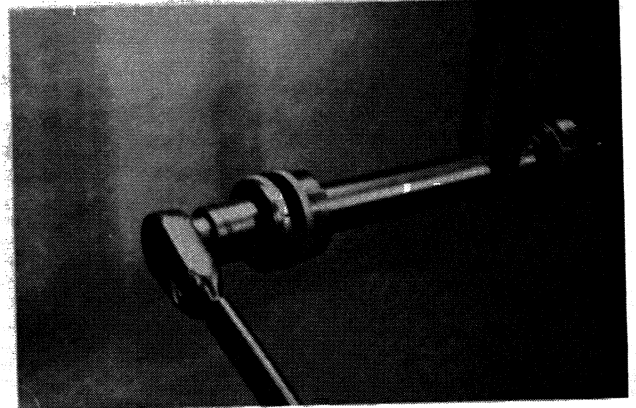

Study **SAFETY RULES** in the front of this manual thoroughly for the protection of machine and safety of personnel.

5.6 SPECIFICATIONS

5.6.2.1 DOZER LIFT CIRCUIT

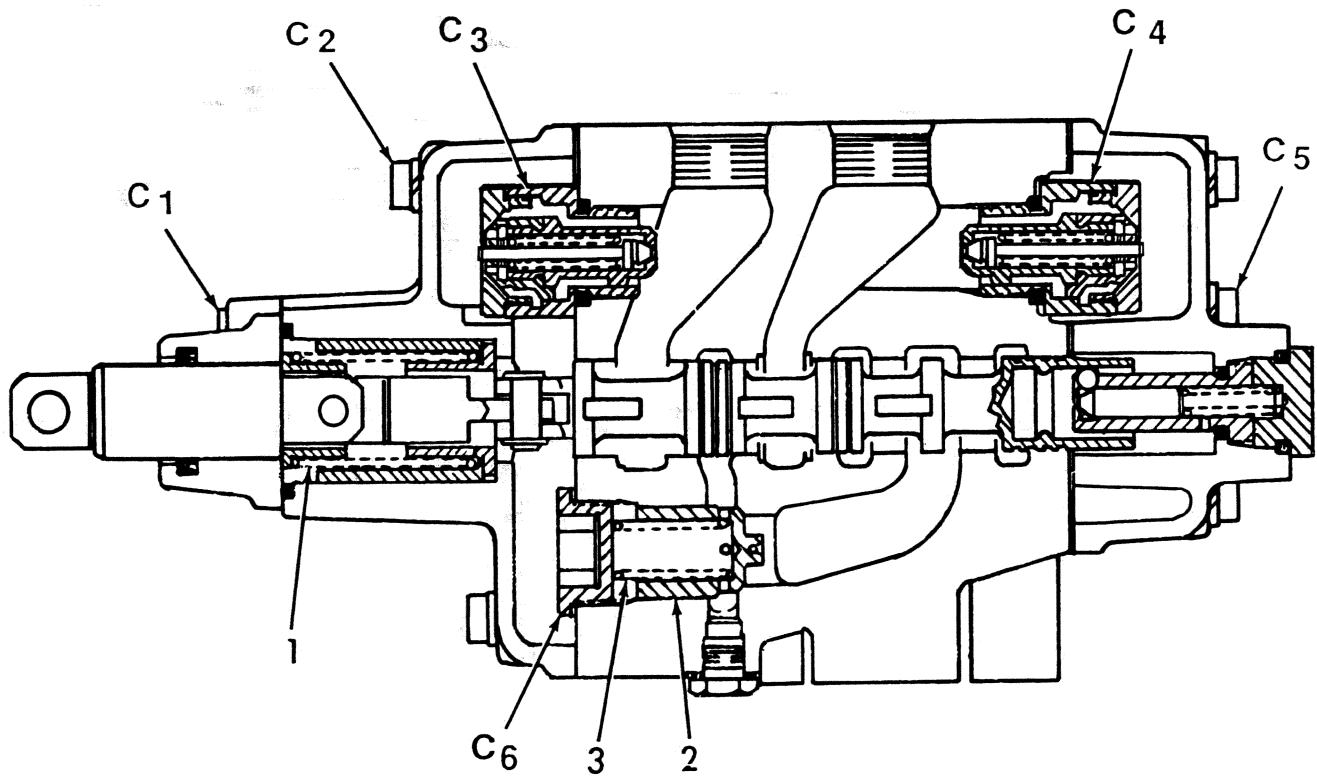

T-100589

1. Spool return spring	
Free length	106mm (4.17 in)
Load when compressed to 53mm (2.09 in)	11.2-12.4 daN(25.18-27.88 lbs)
Load when compressed to 37mm (1.46 in)	14.6-16.2 daN(32.82-36.42 lbs)
2. Check valve O.D.	24.979-25.000mm (.983-.984 in)
Bore in body for check valve	25.040-25.092mm (.986-.988 in)
Clearance	0.040-0.113mm (.0016-.0044 in)
3. Check valve spring	
Free length	45mm (1.77 in)
Load when compressed to 33mm (1.30 in)	0.48-0.52 daN (1.08-1.17 lbs)
Load when compressed to 26.5mm (1.04 in)	0.76-0.84 daN (1.71-1.89 lbs)

TORQUES

C ₁	1.9-2.1 daNm.....(14.01-15.49 lbs.ft)
C ₂	1.9-2.1 daNm.....(14.01-15.49 lbs.ft)
C ₃	11.0-12.0 daNm.....(81.13-88.51 lbs.ft)
C ₄	11.0-12.0 daNm.....(81.13-88.51 lbs.ft)
C ₅	1.9-2.1 daNm.....(14.01-15.49 lbs.ft)
C ₆	1.9-2.1 daNm.....(14.01-15.49 lbs.ft)

Study SAFETY RULES in the front of this manual thoroughly for the protection of machine and safety of personnel.

5.6 SPECIFICATIONS

5.6.7 DOZER TILT CYLINDER (Two Cylinder Application)

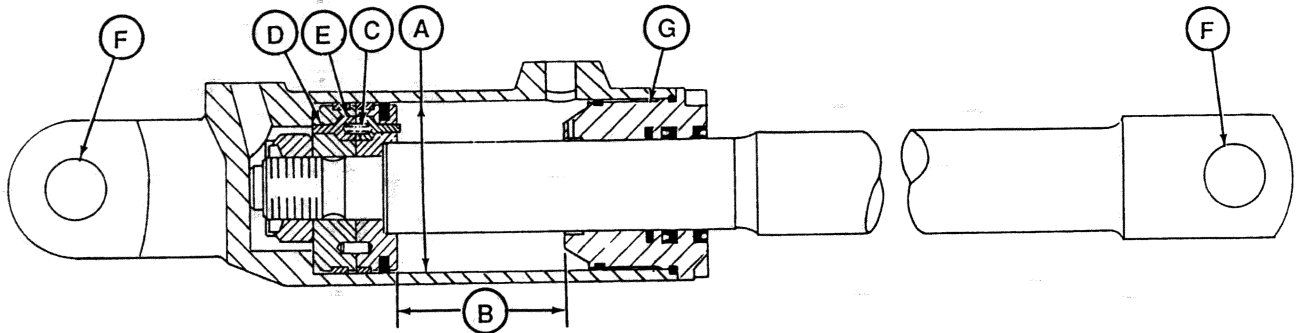

T-100597

A. Nominal diameter of piston	110mm (4.33 in)
B. Stroke of cylinder rod	114mm (4.49 in)
C. Piston cushion valve spring	
Free length	31mm (1.22 in)
Load when compressed to 19mm (0.75 in)	0.95-1.05 Kg (2.09-2.32 lbs)
Load when compressed to 13mm (0.51 in)	1.42-1.58 Kg (3.13-3.48 lbs)
D. Bore in piston half for cushion valve stem	5.030-5.078mm (0.1980-0.1999 in)
Cushion valve stem O.D.	4.970-5.000mm (0.1957-0.1968 in)
Clearance	0.030-0.108mm (0.0012-0.0042 in)
E. Bore in piston half for cushion valve body	15.040-15.098mm (0.5921-0.5944 in)
Cushion valve body O.D.	14.957-15.000mm (0.5888-0.5905 in)
Clearance	0.040-0.141mm (0.0016-0.0056 in)
F. Bore in swivel for pivot pin	40.120-40.280mm (1.5795-1.5858 in)
Pivot pin O.D.	39.840-40.000mm (1.5685-1.5748 in)
Clearance	0.120-0.440mm (0.0047-0.0173 in)
G. Torque of head to cylinder tube	162-178 daNm (1195-1313 lbs.ft)
H. Torque of rod nut	200-220 daNm (1475-1623 lbs.ft)

Study SAFETY RULES in the front of this manual thoroughly for the protection of machine and safety of personnel.

6.1 GENERAL DESCRIPTION

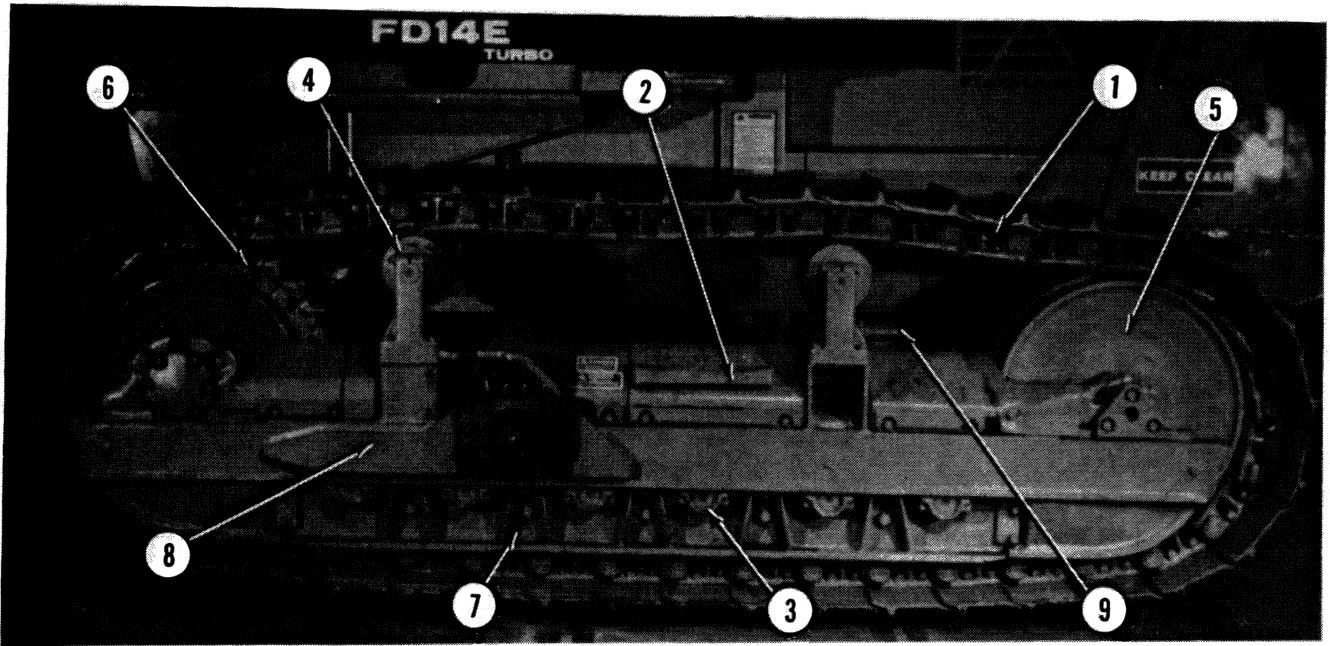

T-93771

- | | | |
|------------------|-------------------------|-----------------------|
| 1 Track chain | 4. Track carrier roller | 7. Track roller guard |
| 2. Track release | 5. Track idler | 8. Track frame |
| 3. Track roller | 6. Sprocket ring gear | 9. Oscillating beam |

6.1.1

Standard track chain is sealed and lubricated, using semi-grouser shoes, 600mm (23.75") wide. Chain is connected by a split master link. Chain tension is adjusted by adding or removing grease at the cylinder.

DANGER

Fluid under pressure. Do not loosen track tension by unscrewing overload relief valve. Do not remove the lube fitting located on top of the ball check assembly. Follow procedures recommended in the undercarriage service manual.

6.1.2

Track release is a straight-push spring design. It absorbs the shock and protects the track chain from possible damage when machine is operated on rough, rocky ground.

DANGER

Track release spring is assembled into machine with high compressive load. Follow procedures recommended in the undercarriage service manual when assembling or disassembling this part.

6.1.3

Track rollers are permanently lubricated and sealed. There are seven rollers on each side, two double flange and five single flange. The double flange rollers are in the #2 and #6 positions.

6.1.4

Track carrier rollers are permanently lubricated and sealed. There are two rollers on each side.

6.1.5

Track idlers are permanently lubricated and sealed. Idlers slide in and out on the track frame and are held under tension by the track release spring.

6.1.6

Sprocket ring gear consists of two bolt-on segments with a total of 27 teeth. Teeth are hardened and have an anti-packing profile.

6.1.7

Track roller guards are optional equipment. They consist of inner and outer guards bolted to the track frame with spacing tubes in between. They help prevent material from getting between the rollers and the chain.

6.1.8

Track frames are welded, box-section type. At the rear, they attach to the main frame and to the sprocket axle. At the front, they are supported by an oscillating beam. Frames can oscillate 200mm (7.87") total.

6.1.9

The oscillating beam is supported by resilient pads on the front portion of the track frame. The rear of the track frame pivots on the sprocket shaft.

Study **SAFETY RULES** in the front of this manual thoroughly for the protection of machine and safety of personnel.

6.4 REPAIR PROCEDURES

6.4.2.1.9

Using a suitable hoist and sling, remove spring assembly.

T-88416



WARNING

Lift and handle all heavy parts with a lifting device of proper capacity. Be sure parts are supported by proper slings and hooks. Use lifting eyes if provided. Watch out for people in the vicinity.

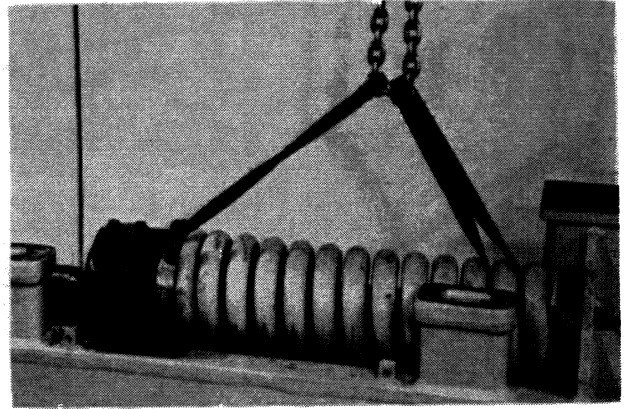

Study **SAFETY RULES** in the front of this manual thoroughly for the protection of machine and safety of personnel.

6.4 REPAIR PROCEDURES

6.4.3.3 ASSEMBLY

6.4.3.3.1

Press in new bushings. Holes in bushings must line up with holes in carrier. Drill and ream dowel holes. Install dowels. End of dowel must not protrude from flange of bushing.

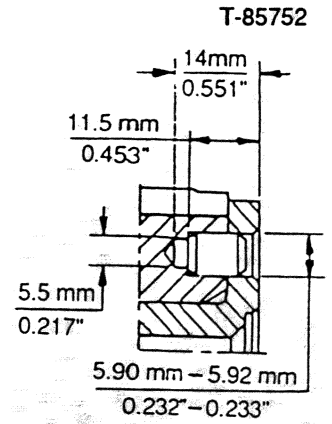
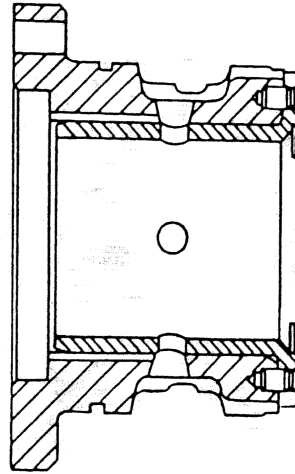

6.4.3.3.2

Install O-ring in groove of carrier. Lubricate O-ring.

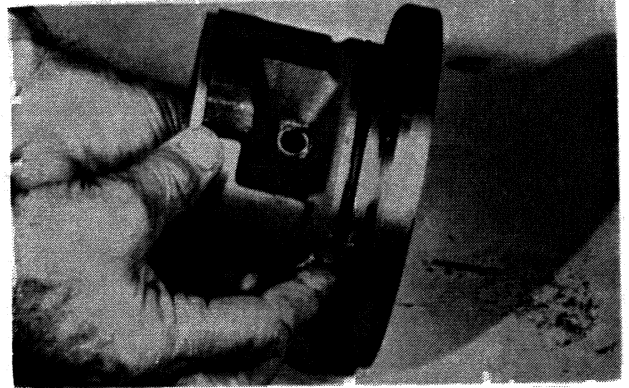

6.4.3.3.3

Install guide studs # 75291525 in roller.

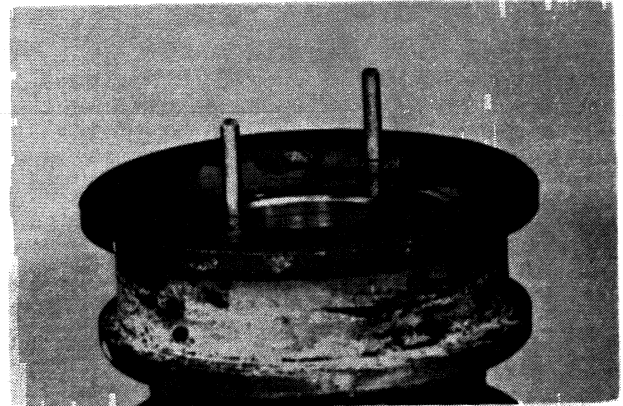

6.4.3.3.4

Position bushing carrier over guide studs. Press carrier into roller. Tighten attaching capscrews to specified torque.

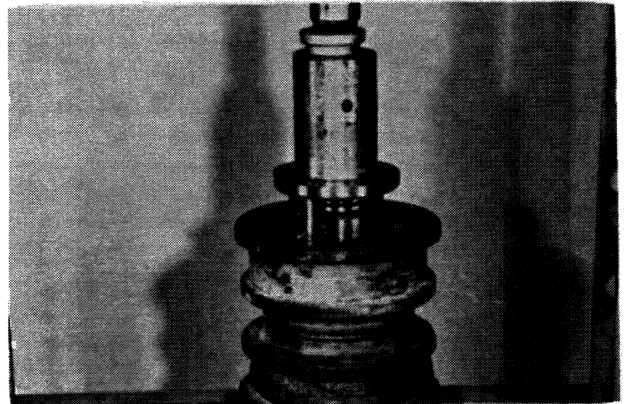

Study SAFETY RULES in the front of this manual thoroughly for the protection of machine and safety of personnel.

6.4 REPAIR PROCEDURES

6.4.5.2.5

Remove seals from support and bushing carrier. Keep seals together if they are to be reused. Do not mix seal halves.

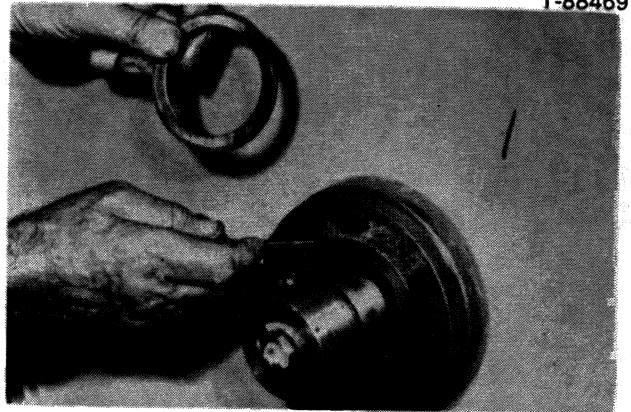

6.4.5.2.6

Support wear pads are replaceable. Remove screws and replace pads. Tighten nuts to specified torque.

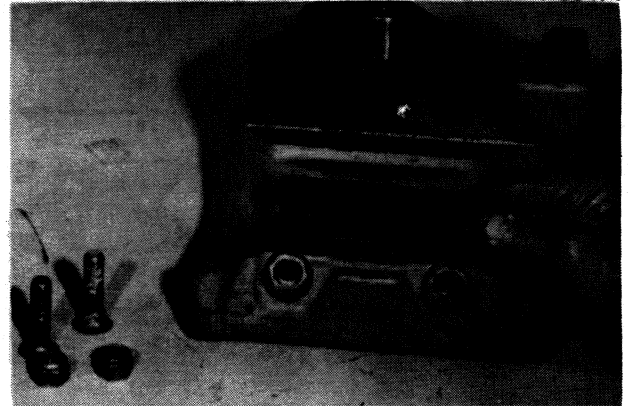

6.4.5.2.7

Remove O-ring from shaft. Remove capscrews attaching bushing carrier.

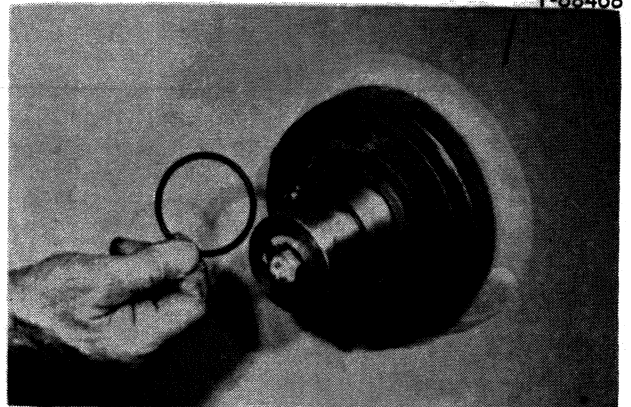

6.4.5.2.8

Place idler in a press. Press against end of shaft to push out lower bushing carrier. Remove capscrews attaching other bushing carrier. Turn idler over. Press against end of shaft to remove other bushing carrier.



WARNING

Lift and handle all heavy parts with a lifting device of proper capacity. Be sure parts are supported by proper slings and hooks. Use lifting eyes if provided. Watch out for people in the vicinity.

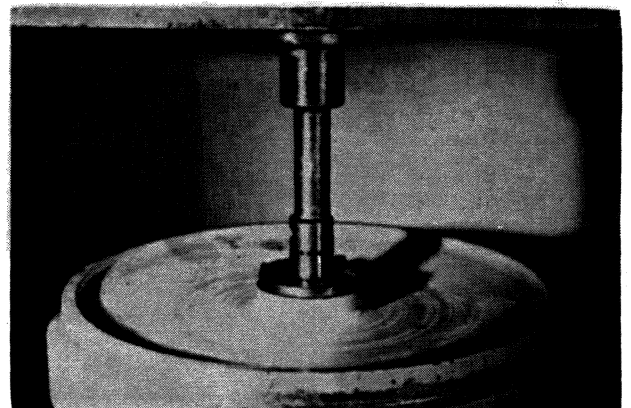

Study SAFETY RULES in the front of this manual thoroughly for the protection of machine and safety of personnel.

6.4 REPAIR PROCEDURES

6.4.8 TRACK FRAME

6.4.8.1 REMOVAL

6.4.8.1.1

Remove the dozer blade from the machine. Refer to the Operation and Maintenance Instruction Manual for procedure.

6.4.8.1.2

Remove track chain as described in Sect. 6.4.1.



DANGER

Fluid under pressure. Do not loosen track tension by unscrewing overload relief valve. Do not remove the lube fitting located on top of the ball check assembly.

6.4.8.1.3

Remove the oscillating beam retaining pin.

6.4.1.8.4

Remove carrier roller support.



WARNING

Lift and handle all heavy parts with a lifting device of proper capacity. Be sure parts are supported by proper slings and hooks. Use lifting eyes if provided. Watch out for people in the vicinity.

T-93754

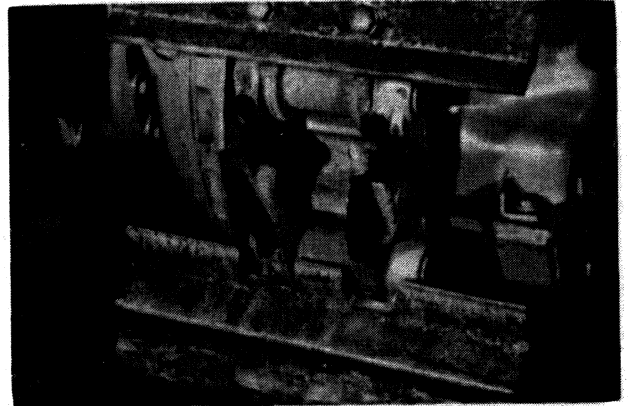

T-93793

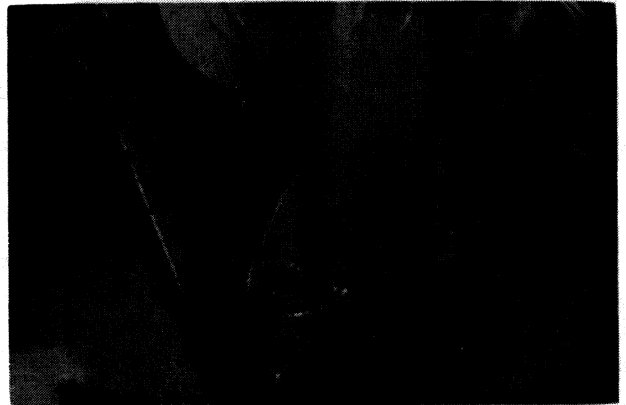

T-93794



Study SAFETY RULES in the front of this manual thoroughly for the protection of machine and safety of personnel.

6.6 SPECIFICATIONS

6.6.3 TRACK ROLLER

A.	Bushing carrier O.D.	114 155	114.20 mm (4.494 - 4.496")
	- Roller bore I.D.	114.00 - 114.035	mm (4.488 - 4.4895")
	- Interference fit	0.12	0.20 mm (0.0045 - 0.008")
B.	Shaft O.D. ...	64.97	65.00 mm (2.558 - 2.559")
	- Bushing I.D. (installed)	65.42 - 65.57	mm (2.576 - 2.581")
	Bushing-to-shaft clearance	0.42 - 0.60	mm (0.017 - 0.023")
C.	Bushing O.D.	74.97 - 75.00	mm (2.9515 - 2.9525")
	Bushing carrier I.D.	74.91	74.96 mm (2.949 - 2.951")
	Interference fit	0.01 - 0.09	mm (0.0005 - 0.0035")
D.	Thickness of shaft thrust ring	17.75 - 17.80	mm (0.699 - 0.701")
E.	Thickness of bushing flange	4.75 - 4.80	mm (0.187 - 0.189")
	End play	0.30 - 0.75	mm (0.011 - 0.030")
	- Maximum allowable end play	1.2	mm (0.047")
F.	Roller diameter	213.8	214.0 mm (8.417 - 8.425")
	- Wear limit	200.0	mm (7.874")
G.	Roller rail surface width(double flange)	48.0	49.0 mm (1.890 - 1.929")
	Wear limit	62.0	mm (2.441")

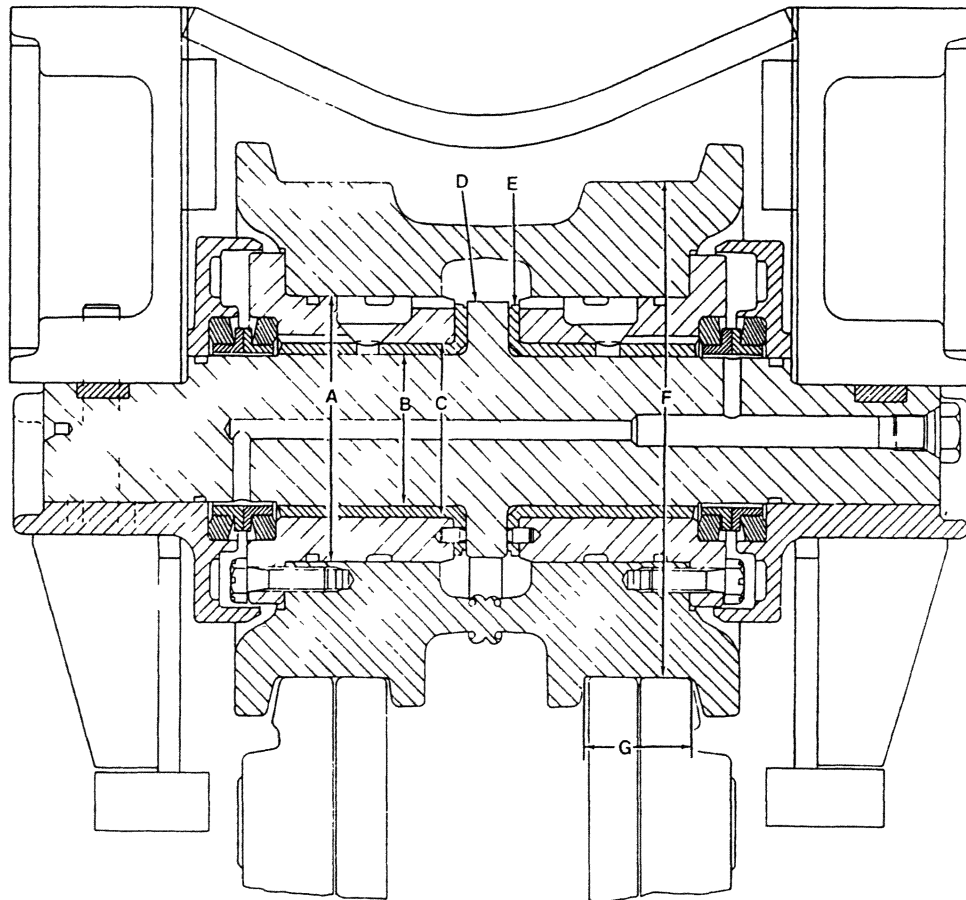

T-85755

Study SAFETY RULES in the front of this manual thoroughly for the protection of machine and safety of personnel

CONNECTOR GROUP

- A. Fuse Block (machine)
- B. Fuse Block (cab)
- C. To Cold Weather Starting Aid Wire Group
- D. To Machine Wire Group
- E. To Electromagnet Engine Shut-off Solenoid
- F. To Electromagnet Engine Shut-off Solenoid
- G. To Electronic Data Monitor (Socket "B")
- H. To Electronic Data Monitor (Socket "A")
- I. To Machine Wire Group
- J. To Machine Wire Group
- K. To Instrument and Control Panel Wire Group
- L. To Instrument and Control Panel Wire Group
- M. To Engine Oil Pressure & Hour Meter Switch
- N. To Engine Coolant Level Sensor (E.D.M.)
- O. To Tachometer Pickup (E.D.M.)
- P. To right hand Brake Warning Switch (E.D.M.)
- Q. To left hand Brake Warning Switch (E.D.M.)
- R. To Buzzer (E.D.M.)
- S. To Instrument Panel Indicator Lights
- T. To Tachometer (E.D.M.)
- U. To Hour Meter (E.D.M.)
- V. To Electronic Gauge Panel
- W. To Machine Wire Group
- X. To Transmission Oil Temperature Sensor (E.G.P.)
- Y. To Transmission Oil Pressure Sensor (E.G.P.)
- Z. To Water Temperature Sensor (E.G.P.)
- A1. To Engine Oil Pressure Sensor (E.G.P.)
- B1 To Cab Wire Group
- C1 To Dash Light
- D1. To Cab Wire Group
- E1 To front Light, left hand
- F1 To front Light, right hand
- G1 To ROPS rear Flood Lights Wire Group
- H1 To ROPS front Flood Lights Wire Group
- I1 To rear Flood Light, left hand
- J1. To rear Flood Light, right hand
- K1. To front Flood Light, left hand
- L1 To front Flood Light, right hand
- M1 To Connector "M1" for left rear Flood Light
- N1. To Connector "N1" for left rear Flood Light
- O1 To Connector "O1" for right rear Flood Light
- P1. To Connector "P1" for right rear Flood Light
- Q1 To rear Flood Light, left hand
- R1 To rear Flood Light, right hand
- S1 To Connector "S1" for left front Flood Light
- T1. To Connector "T1" for left front Flood Light
- U1 To Connector "U1" for right front Flood Light
- V1. To Connector "V1" for right front Flood Light
- W1. To front Flood Light, left hand
- X1 To front Flood Light, right hand
- Y1. To front Wiper Switch
- Z1 To rear Wiper Switch
- A2. To left hand Door Wiper Switch
- B2. To right hand Door Wiper Switch

Study SAFETY RULES in the front of this manual thoroughly for the protection of machine and safety of personnel.

IGNITION & STARTER GROUP

	ITEM #	WIRE #
Dash Ignition Switch to Push Button Switch, Cold Weather Starting Aid	1	860
Push Button Switch, Cold Weather Starting Aid to Connector "C"	2	860
Dash Ignition Switch to Frame Ignition Switch (via Connector D)	3	802
Dash Ignition Switch to Starter Relay (via Connector D)	4	802
Dash Ignition Switch to Frame Ignition Switch (via Connector D)	5	892
Diode Relay to Frame Ignition Switch (via Connector D)	6	801
Diode Relay to ROPS Relay	7	801
Diode Relay to Dash Ignition Switch	8	804
ROPS Relay to Starter Relay	9	777
Cab Relay to Starter Relay	10	777
Cab Relay to Fuse Block, Cab	11	887
Cab Relay to Fuse Block, Cab	12	887
Cab Relay to Dash Ignition Switch	13	891
Starter Relay to Fuse Block, Cab & also to Fuse Block, Machine	14	777
Starter Relay to Frame Ignition Switch (via Connector D)	15	777
Connector D to Electromagnet Engine Shut-off Solenoid	16	903
Starter to Electromagnet Engine Shut-off Solenoid	17	869
Starter to Excess Fuel Solenoid	18	888
Starter to Starter Relay	19	888
Starter to Starter Relay	20	777
Starter to Alternator	21	777
Cold Weather Starting Aid Valve to Connector C	22	None
External Starting Aid Connector to Battery	23	None
External Starting Aid Connector to Ground	24	None
Battery to Starter	25	None
Battery to Battery	26	None
Battery to Master Switch	27	None
Master Switch to Ground	28	None
ROPS Relay to Starter Relay	0	000
Cab Relay to Ground	0	000
Starter Relay to Ground	0	000
Electromagnet Engine Shut-off Solenoid to Ground	0	000
Excess Fuel Solenoid to Ground	0	000
Cold Weather Starting Aid Valve to Ground	0	None

Study SAFETY RULES in the front of this manual thoroughly for the protection of machine and safety of personnel.

IGNITION & STARTER GROUP

PUSH BUTTON SWITCH, COLD WEATHER STARTING AID "IB"

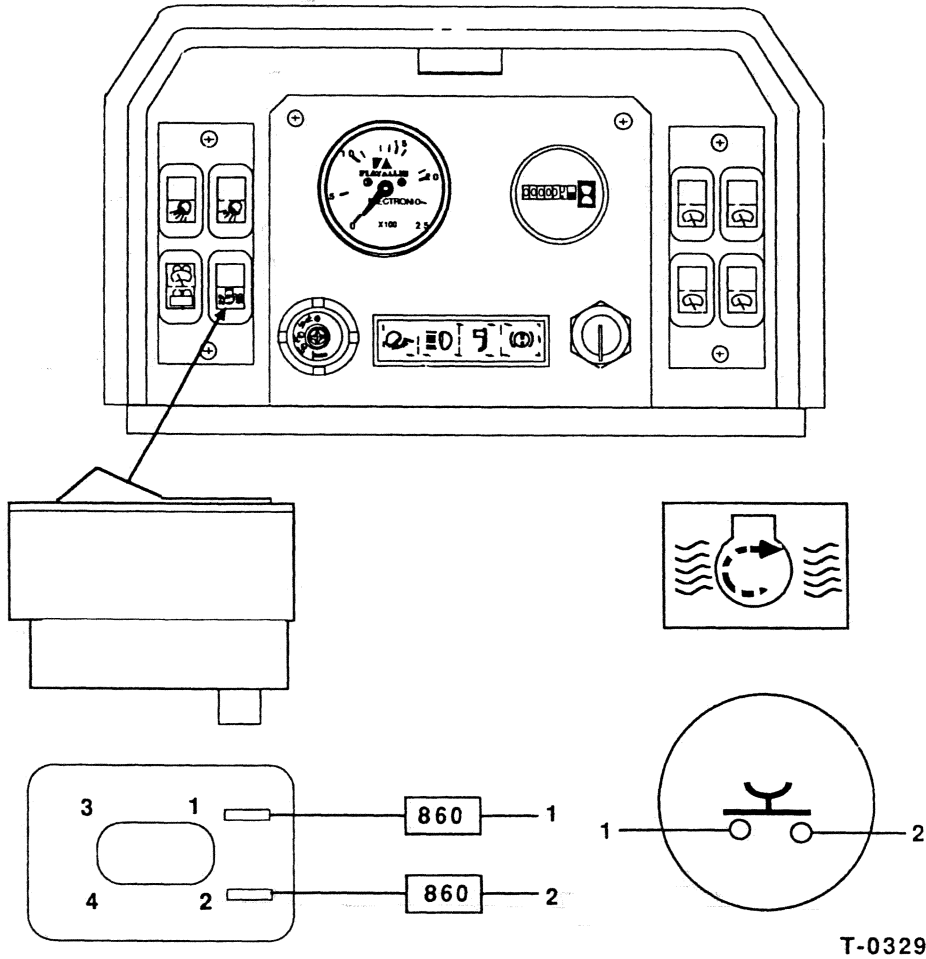

T-0329

ITEM # WIRE #

- 1 860 Position "1" to Dash Ignition Switch "IA" Position "50"
- 2 860 Position "2" to Connector "C" (NOTE: from Connector "C" to Valve, the wire will not have a number)

LOCATION: Left hand side of front Dash Instrument Panel and Cover.

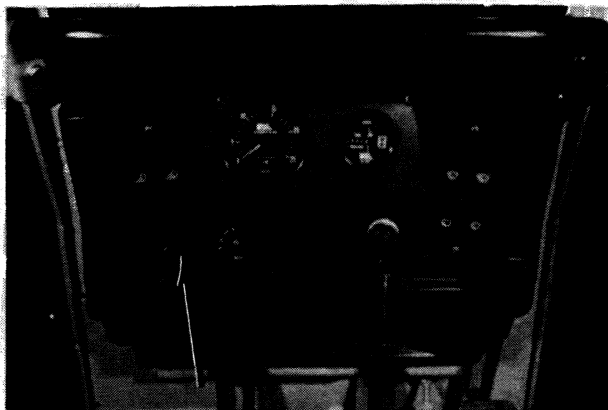

T-93472A

Study **SAFETY RULES** in the front of this manual thoroughly for the protection of machine and safety of personnel.

IGNITION & STARTER GROUP
ELECTROMAGNET ENGINE SHUT-OFF SOLENOID "IL"

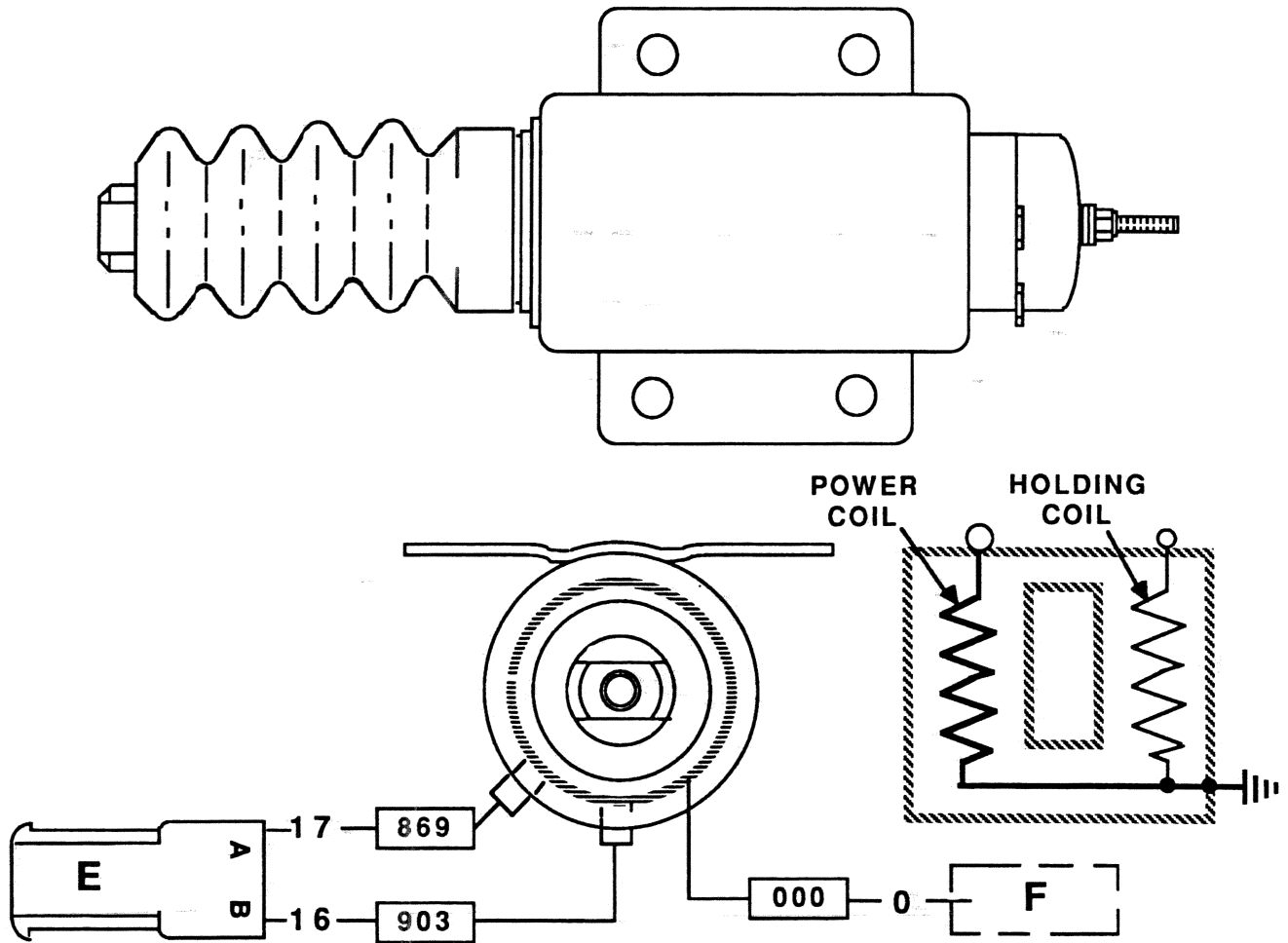

T-0333

ITEM 3 WIRE #

16	903	Connector "E" Position "B" to Connector "D" Position "1"
17	869	Connector "E", Position "A" to Starter "II"
0	000	Connector "F" to Ground.

LOCATION: Rear of Engine on right hand side, above Starter.

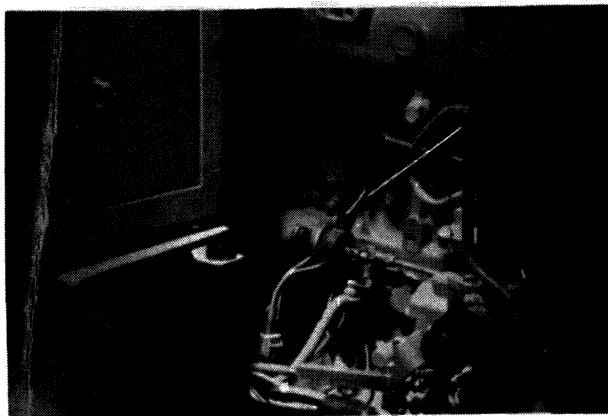

T-93457

Study SAFETY RULES in the front of this manual thoroughly for the protection of machine and safety of personnel.

Study SAFETY RULES in the front of this manual thoroughly for the protection of machine and safety of personnel.

ELECTRONIC DATA MONITOR (E.D.M.) GROUP
ELECTRONIC DATA MONITOR "EA", CONNECTOR "H" ("A" SOCKET)

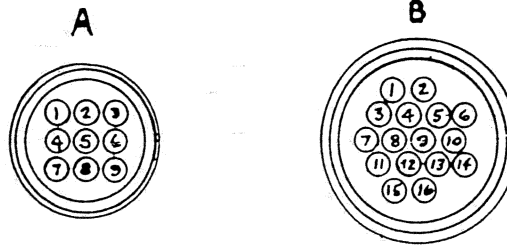
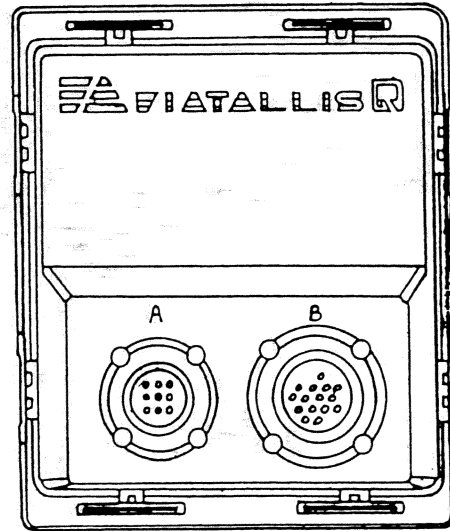
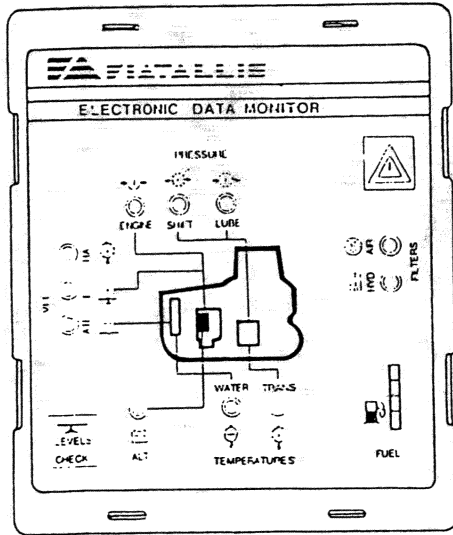

POSITION # ITEM 3 WIRE#

1	40	581	To Connector "J", Position "3" Connector "J" to Transmission Oil Pressure Switch "EG".
2	41	589	To Connector "I" Position "7", Connector "I" to Transmission Oil Level Sensor "EH"
3	None	None	
4	42	569	To Connector "I" Position "4", Connector "I" to Engine Oil Level Sensor "EI"
5	43	520	To Connector "J" Position "2" Connector "J" to Connector "N" Position "B" Engine Coolant Level Sensor "EJ"
6	44	888	To Starter Relay "IC"
7	45	555	To Connector "J" Position "1" Connector "J" to Fuel Level Sensor "EK"
8	46	557	To Connector "J", Position "4" Connector "J" to Fuel Level Sensor "EK"
9	None	None	

LOCATION: Left hand side of Operator Seat, in Console.

Study **SAFETY RULES** in the front of this manual thoroughly for the protection of machine and safety of personnel.

**ELECTRONIC DATA MONITOR (E.D.M.) GROUP
FUEL LEVEL SENSOR "EK"**

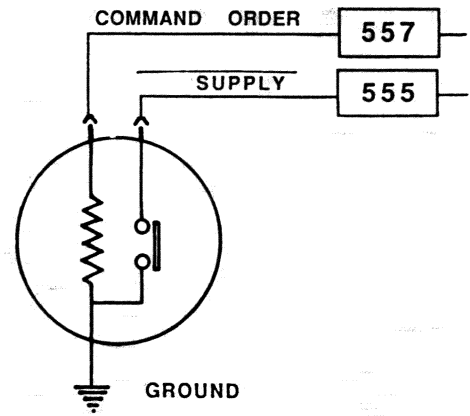
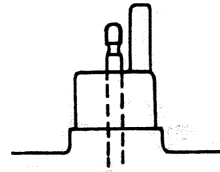
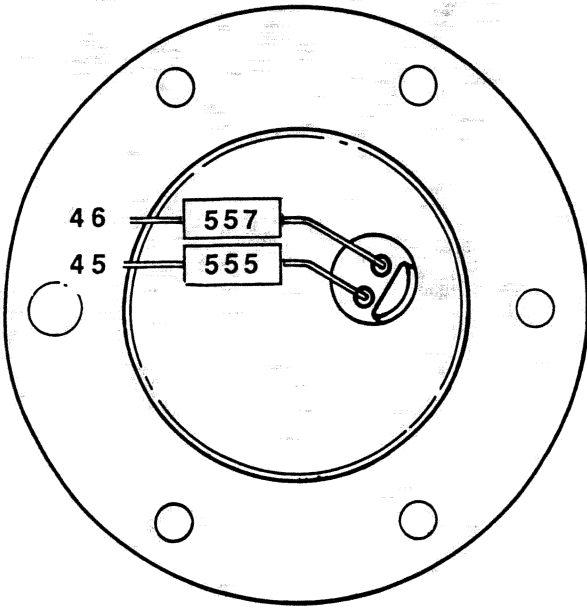

T-023

ITEM # WIRE #

- | | | |
|----|-----|---|
| 45 | 555 | To Connector "J", Position "1", Connector "J" to Connector "H" Position "7" E.D.M. "EA" |
| 46 | 557 | To Connector "J", Position "4" Connector "J" to Connector "H" Position "8" E.D.M. "EA" |

LOCATION: Rear of Tractor, in the center, top of Fuel Tank.



T-93489

Study SAFETY RULES in the front of this manual thoroughly for the protection of machine and safety of personnel.

ELECTRONIC GAUGE PANEL (E.G.P.) GROUP

Panel & Sensor

- GA. Electronic Gauge Panel**
- GB. Transmission Oil Temperature Sensor**
- GC. Transmission Oil Pressure Sensor**
- GD. Water Temperature Sensor**
- GE. Engine Oil Pressure Sensor**

Study SAFETY RULES in the front of this manual thoroughly for the protection of machine and safety of personnel.

ELECTRONIC GAUGE PANEL (E.G.P.) GROUP
TRANSMISSION OIL TEMPERATURE SENSOR "GB"

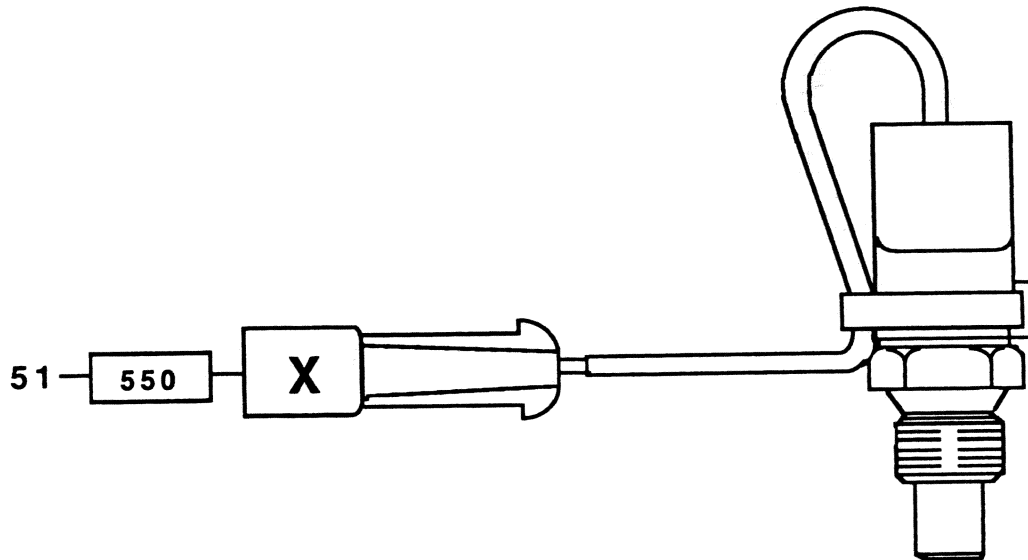

T-0375

ITEM # WIRE #

51 550 Connector "X" to Connector "W" Position "3" Connector "W" to Connector "V" Position "8"
E.G.P "GA"

LOCATION: Rear of Engine on left hand side in Oil Cooler Manifold Block on the back inside.

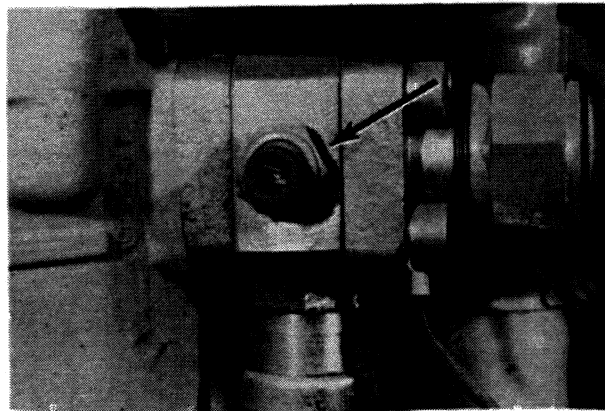

T-93604

Study SAFETY RULES in the front of this manual thoroughly for the protection of machine and safety of personnel.

HORN & BACKUP ALARM GROUP

MACHINE WIRE GROUP

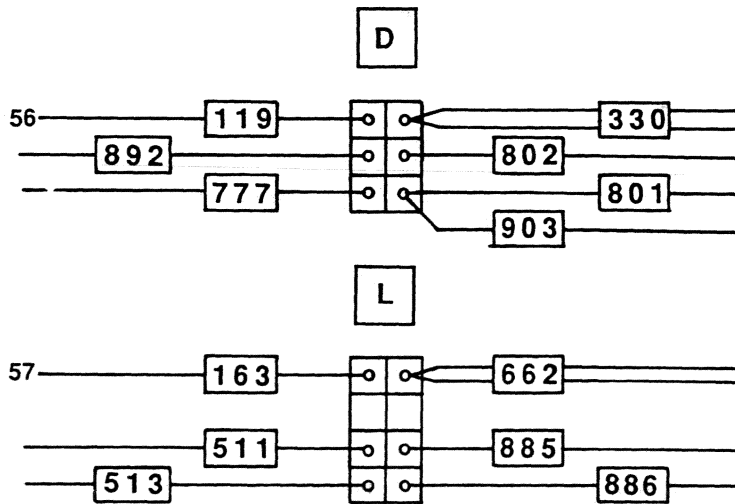
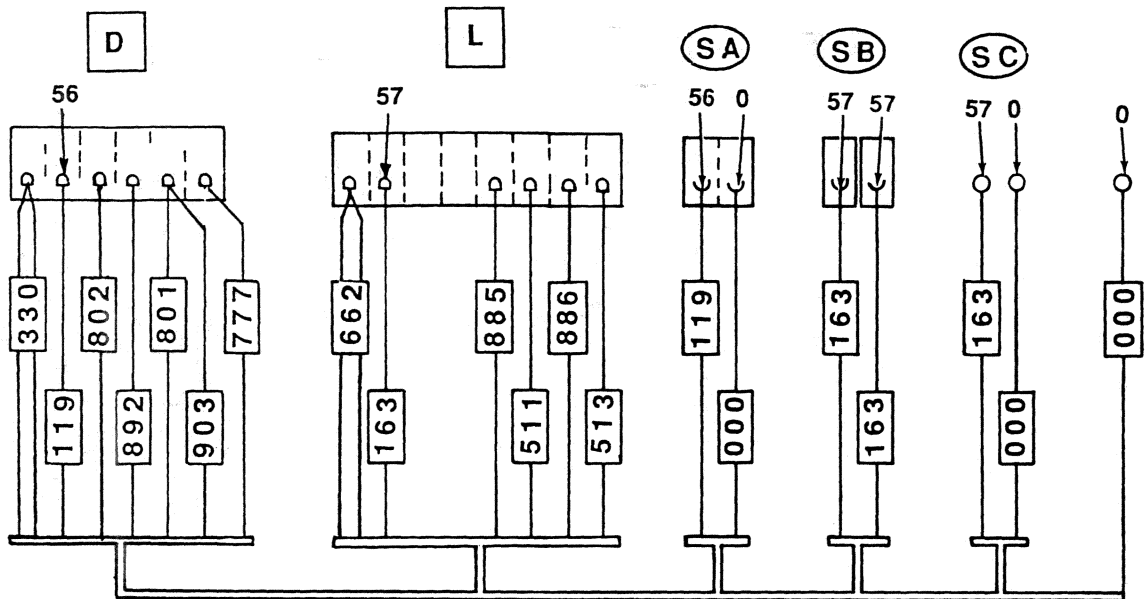

T-0585

Study SAFETY RULES in the front of this manual thoroughly for the protection of machine and safety of personnel.

LIGHTING GROUP

Cab Wire Group, Connector "W1"

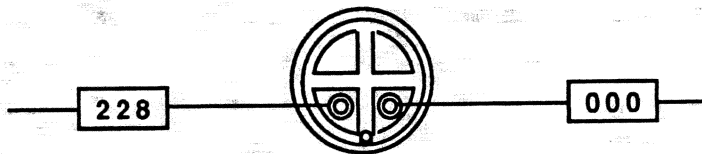

Cab Wire Group, Connector "X1"

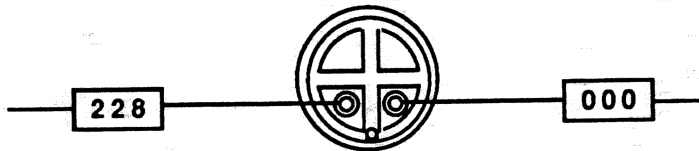

T-0584(8)

Instrument & Control Panel Wire Group

Study SAFETY RULES in the front of this manual thoroughly for the protection of machine and safety of personnel.

LIGHTING GROUP

ITEM # WIRE

67	330	Position "1" to Connector "D", Position "3" Connector "D" to Connector "E1" Position "1" Front Head Light, left hand "LF", also Connector "D" to Connector "F1" Position "1" Front Head Light, right hand "LG".
68	721	Position "8" to Lighter Receptacle & Light "LL"
69	441	Position "8" to Dome Light "LM"
—	777	See Ignition & Starter Group.
—	899	See Radio Group.
—	116	See Horn & Backup Alarm Group.
—	163	
—	511	See Electronic Data Monitor Group.
—	864	
—	871	

NOTE: Item #63, wire #224 & item #64, wire #228, Fuses act as inline fuses, power is supplied through Light & Horn Switch "LA"

LOCATION: Lower left hand side of front Dash Instrument Panel & Cover.

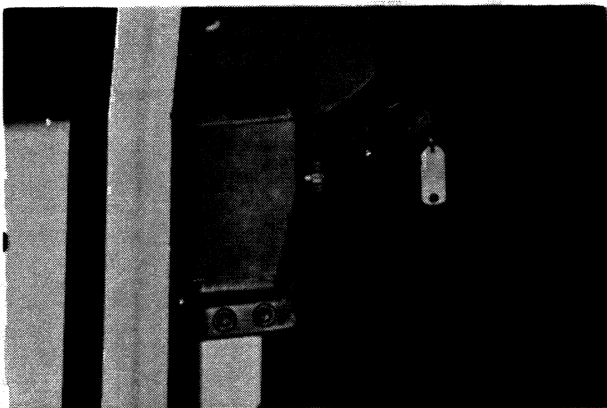

T-93503

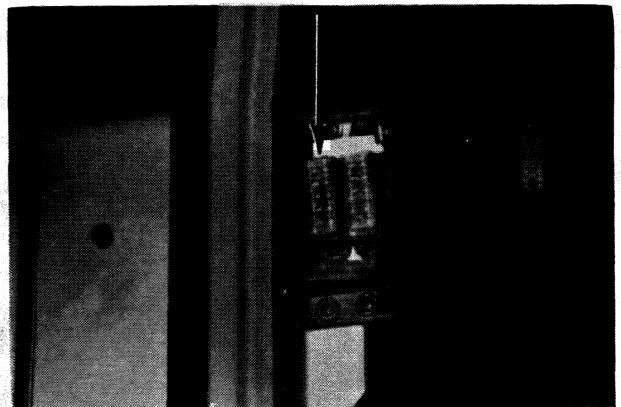

T-93504

Study SAFETY RULES in the front of this manual thoroughly for the protection of machine and safety of personnel.

LIGHTING GROUP
FRONT FLOOD LIGHT, LEFT HAND "LJ" (ROPS)

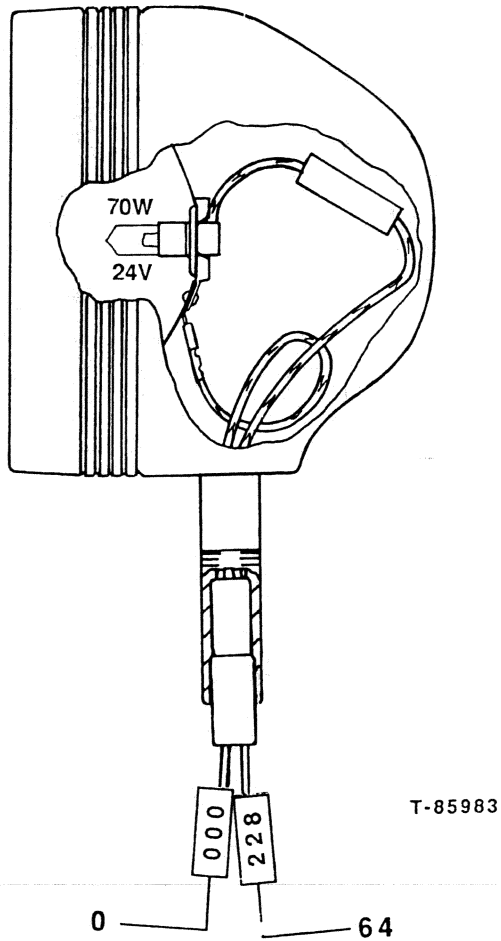

ITEM # WIRE #

64	228	To Connector "H1", Position "B" Connector "H1" to Fuse Block "A" machine, Position "5" Fuse Block "A" machine, Position "6" to Front Flood Lights Switch "LD" (NOTE: Fuse acts as a inline fuse, power comes from Light & Horn Switch "LA").
0	000	To Ground.

LOCATION: Left hand front top corner of ROPS (Note: same location as on a cab).



T-93545

Study SAFETY RULES in the front of this manual thoroughly for the protection of machine and safety of personnel.

WIPER & WASHER GROUP

Switches, Motors & Washer Containers and Pumps

- WA. Front Wiper Switch
 - WB. Rear Wiper Switch
 - WC. Left Hand Door Wiper Switch
 - WD. Right Hand Door Wiper Switch
 - WE. Window Washer Switch
 - WF. Front Wiper Motor
 - WG. Rear Wiper Motor
 - WH. Left Hand Door Wiper Motor
 - WI. Right Hand Door Wiper Motor
 - WJ. Door Window Washer Container & Pump
 - WK. Front & Rear Window Washer Container & Pump
-
- B. Fuse Block, Cab

Study SAFETY RULES in the front of this manual thoroughly for the protection of machine and safety of personnel.

WIPER & WASHER GROUP
LEFT HAND DOOR WIPER SWITCH "WC"

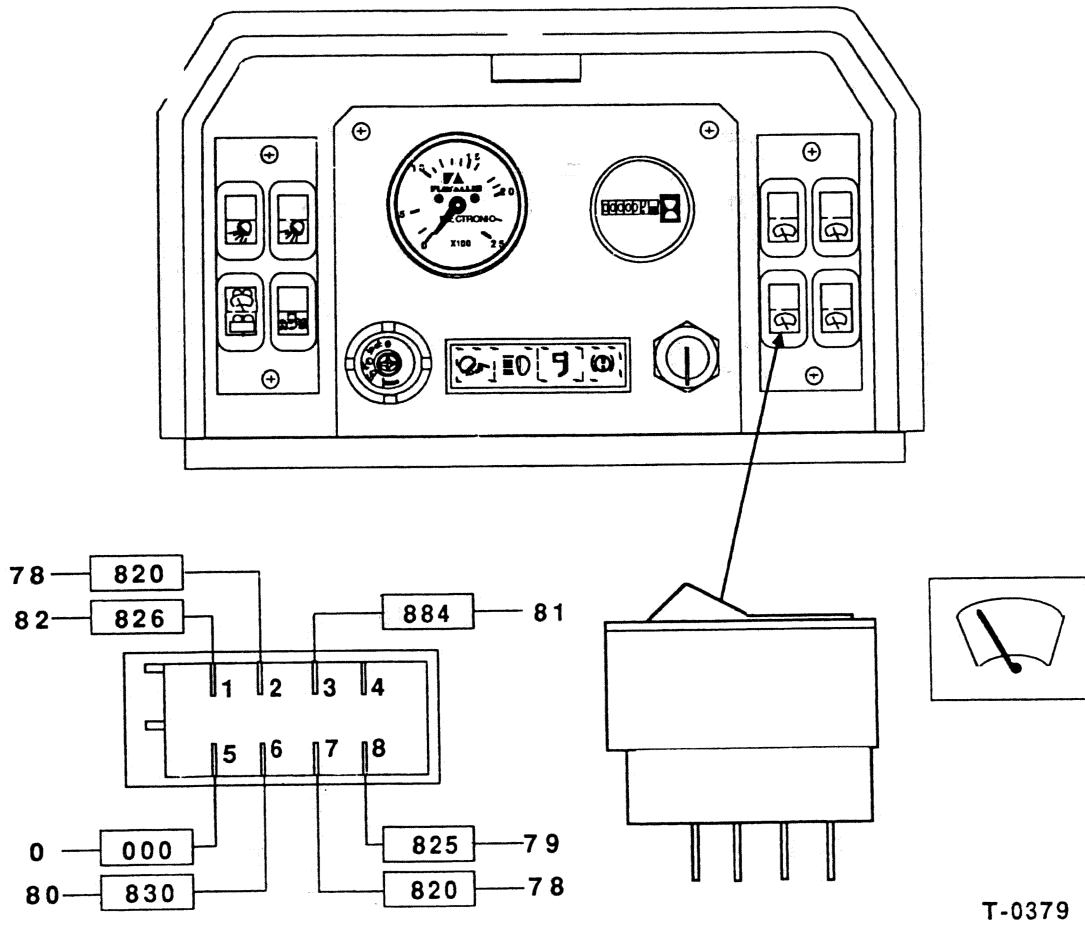

T-0379

ITEM # WIRE #

- | | | |
|----|-----|---|
| 78 | 820 | Position "7" to Fuse Block "B" Cab, Position "3" also Position "7" to Position "2" of Switch. |
| 79 | 825 | Position "8" to Connector "F2" left hand Door Wiper Motor "WH" |
| 80 | 830 | Position "6" to Connector "F2" left hand Door Wiper Motor "WH" |
| 81 | 884 | Position "3" to Connector "F2" left hand Door Wiper Motor "WH" |
| 82 | 826 | Position "1" to Connector "F2" left hand Door Wiper Motor "WH" |
| 0 | 000 | Position "5" to Ground. |

LOCATION: Front Dash Instrument Panel & Cover.

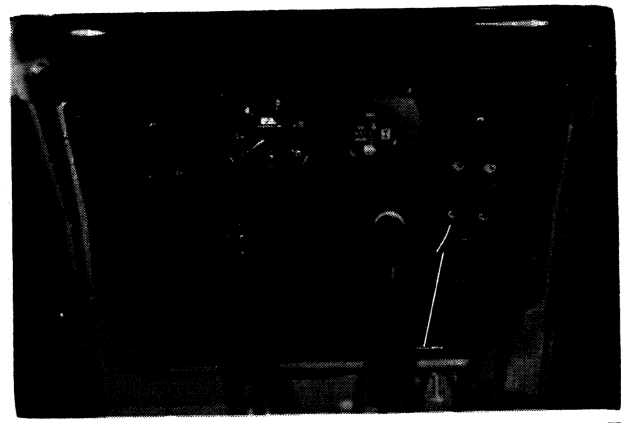

T-93472A

Study SAFETY RULES in the front of this manual thoroughly for the protection of machine and safety of personnel.

HEATER & AIR CONDITIONING GROUP

	ITEM #	WIRE#
Heater Control Switch to Fuse Block, Cab	91	711
Heater Control Switch to Resistor, Resistor to Blower Motor	92	745
Heater Control Switch to Resistor	93	706
Heater Control Switch to Resistor	94	709
Heater Control Switch to Air Conditioning Control Switch	95	784
Jumper Wire on Air Conditioning Control Switch	96	657
Air Conditioning Control Switch to Thermostat	97	824
Relay Air Conditioning to Fuse Block, Cab	98	809
Relay, Air Conditioning to Pressure Switch, Receiver/Dryer	99	819
Relay, Air Conditioning to Condenser Electrofans	100	803
Thermostat to Pressure Switch, Receiver/Dryer	101	824
Connector "Q2" to compressor electromagnetic clutch (NOTE: This wire ties into Item #99, Wire #819, in this Connector, for power)	102	890
Blower Motor to Ground	0	000
Air Conditioning Control Switch to Ground	0	000
Condenser Electrofans to Ground	0	000

Study SAFETY RULES in the front of this manual thoroughly for the protection of machine and safety of personnel.

HEATER & AIR CONDITIONING GROUP

HEATER CONTROL SWITCH "HA"

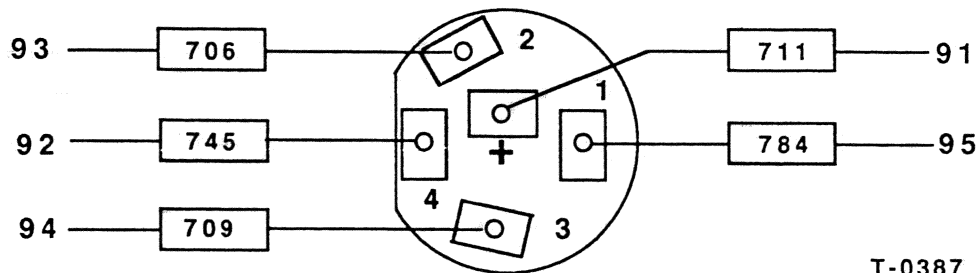
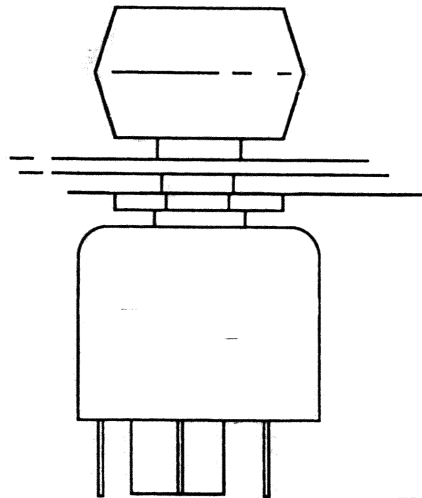

ITEM # WIRE

91	711	Position "+" to Connector "K" Position "2" Connector "K" to Fuse Block "B" Cab, Position "11"
92	745	Position "4" to Connector "L2" Position "B" Heater, Air Conditioning & Blower Unit "HC" Connector "L2" to Resistor "HD" and to Motor "HE"
93	706	Position "2" to Connector "M2" Position "B" Heater, Air Conditioning & Blower Unit "HC" Connector "M2" to Resistor "HD"
94	709	Position "3" to Connector "M2" Position "A" Heater, Air Conditioning & Blower Unit "HC" Connector "M2" to Resistor "HD"
95	784	Position "1" to Connector "K2" Position "A", Air Conditioning Control Switch "HB"

LOCATION: Left hand side of Operator's Seat, in Console next to E.D.M. & E.G.P panels.

Study SAFETY RULES in the front of this manual thoroughly for the protection of machine and safety of personnel.

RADIO GROUP

- RA. Radio Voltage Regulator**
- RB. Radio & Antenna**
- RC. Left hand Speaker**
- RD. Right hand Speaker**

NOTE: Unit may or may not have a radio voltage regulator.

Study SAFETY RULES in the front of this manual thoroughly for the protection of machine and safety of personnel.

ELECTRONIC DATA MONITOR

T-92094A

7 11 FUNCTION

7.11.1

The Electronic Data Monitor is similar to dash lights on your automobile which signal low engine pressure, hot coolant and low battery charge. There is a signal device to sense the individual circuit just like on your car. The Electronic Data Monitor used on the FD14E monitors various systems within the power train. The Data Monitor is a non-serviceable panel made up of a circuit board and Light Emitting Diodes (L.E.D.). The function of the data monitor is to assist the operator in diagnosing problems which may occur while the machine is operating. If a pressure or temperature malfunction occurs in the tested systems, the monitor will sense the malfunction and signal the operator by means of a light and buzzer.

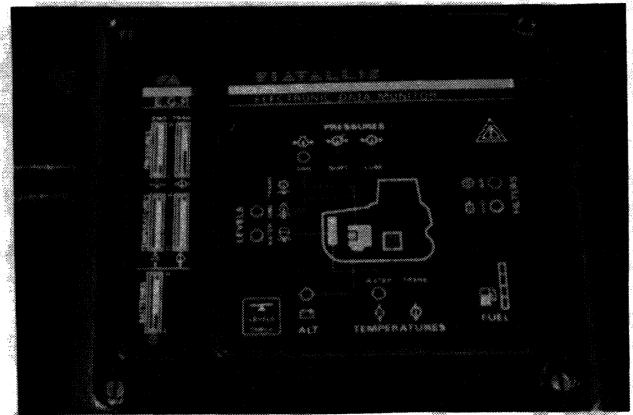

Systems monitored while the machine is running.

- Battery charge
- Coolant maximum temperature
- Converter oil maximum temperature
- Engine lubrication pressure
- Transmission shift pressure
- Transmission lubrication pressure
- Air Cleaner filter restriction
- Implement oil filter restriction
- Fuel level

Systems monitored prior to start up.

- Transmission oil level
- Engine oil level
- Engine coolant level

7 11.2

The monitor is self diagnosing in that each time the machine's electrical system is energized a series of tests are performed on the monitor.

As the operator turns on the master switch and the instrument panel key switch to the first position, the monitor's warning lights begin to flash for approximately 6 to 8 seconds. The operator should note whether all lights are flashing. If all the lights flash, the monitor lights are operating properly.

T-92094B

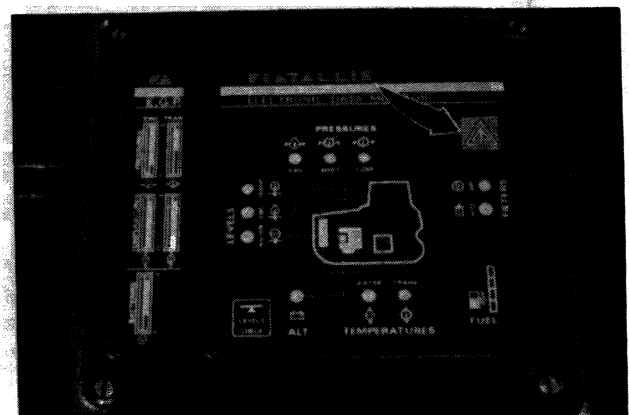

Study SAFETY RULES in the front of this manual thoroughly for the protection of machine and safety of personnel.

FUEL LEVEL DOES NOT REGISTER CORRECTLY

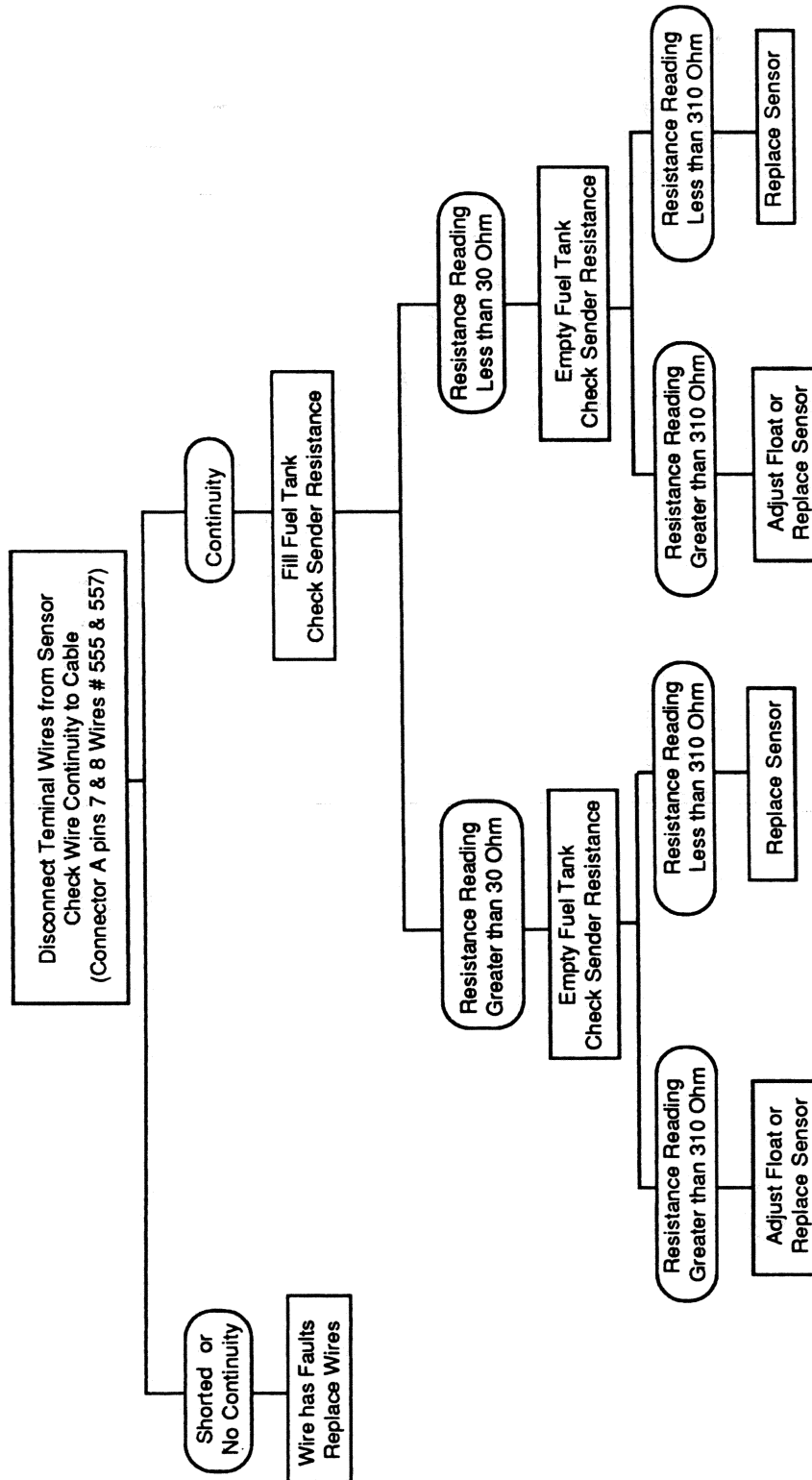

Study SAFETY RULES in the front of this manual thoroughly for the protection of machine and safety of personnel.

**ELECTRONIC GAUGE PACKAGE
TRANSMISSION TEMPERATURE SENDER**

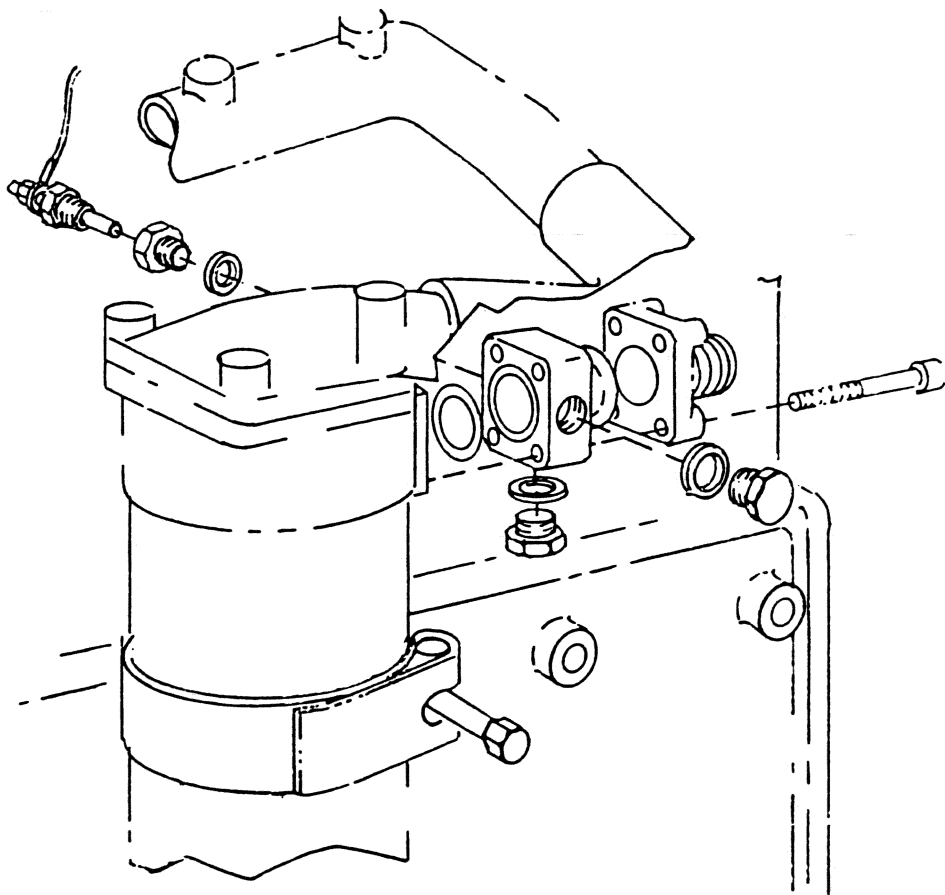
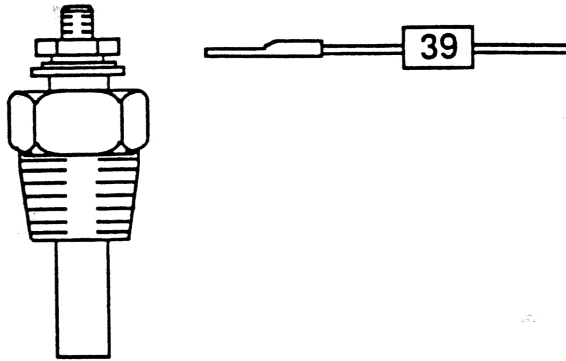

ITEM# WIRE#

10 39

LOCATION: On the back side of a spacer on the upper oil cooler to transmission tube.

Study SAFETY RULES in the front of this manual thoroughly for the protection of machine and safety of personnel.

8.1 GENERAL DESCRIPTION

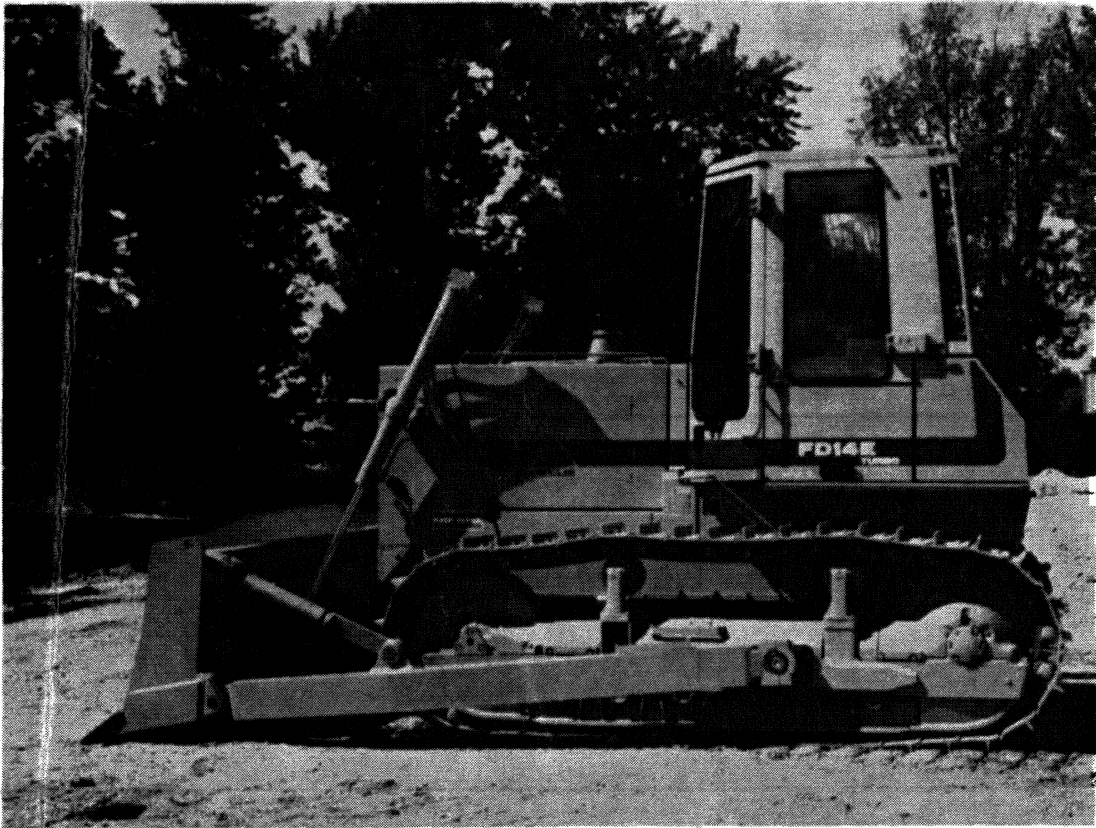

T-93308

8.1.1

Cab is certified as a roll-over protective structure (ROPS).

8.1.2

Standard features include heater, defroster, front and rear window wipers and washers, dome light, safety glass, rear-view mirror, sun visor, sliding rear window and door window wipers and washers.

8.1.3

Doors are equipped with locks and keys for security. Doors can be latched in the open position.

8.1.4

Major components such as hydraulic tank, hydraulic pump and valve, steering control valve, drive shafts and transmission can be repaired by tilting the cab to the left hand side..

8.1.5

Cab serial number is located on a plate mounted in the center front face of seat support frame.

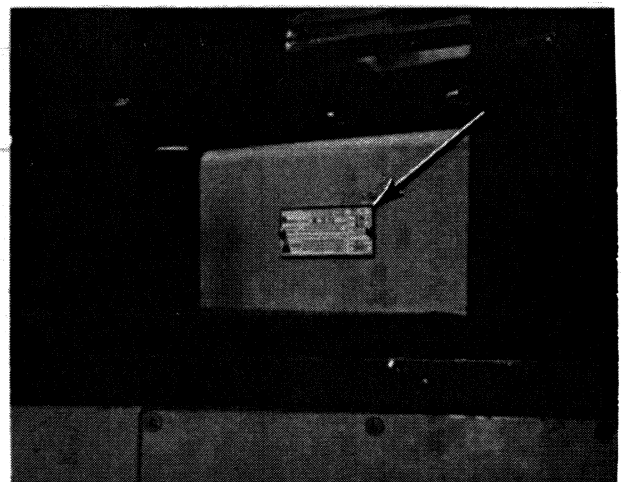

CAB S/N LOCATION

T-93502

Study **SAFETY RULES** in the front of this manual thoroughly for the protection of machine and safety of personnel.

8.3 REPAIR PROCEDURES

8.3.3.2 INSIDE PANELS & HEAD LINER

Various panels inside the cab provide both an attractive interior and easy access to accessories. The following is a list of panels and their locations.

8.3.3.2.1

Front dash instrument panel, cover and floor mat.



8.3.3.2.2

Head liner, side retainers and dome light.

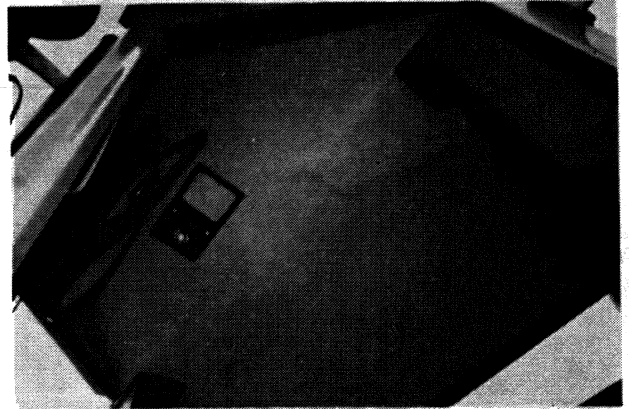

8.3.3.2.3

Head liner front retainer.

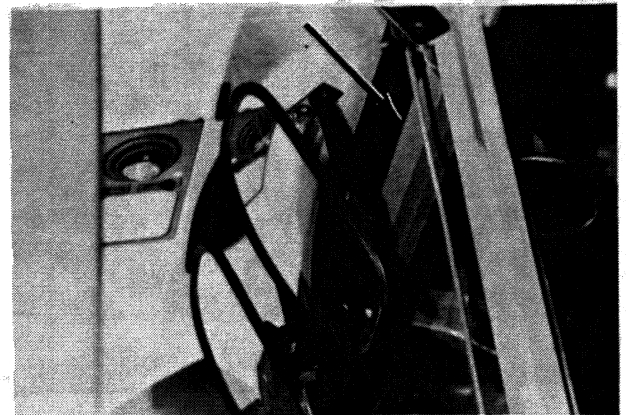

Study SAFETY RULES in the front of this manual thoroughly for the protection of machine and safety of personnel.

8.3 REPAIR PROCEDURES

8.3.3.6.3

Remove four (4) retaining screws from cover, two (2) on each side of cover.

T-93475

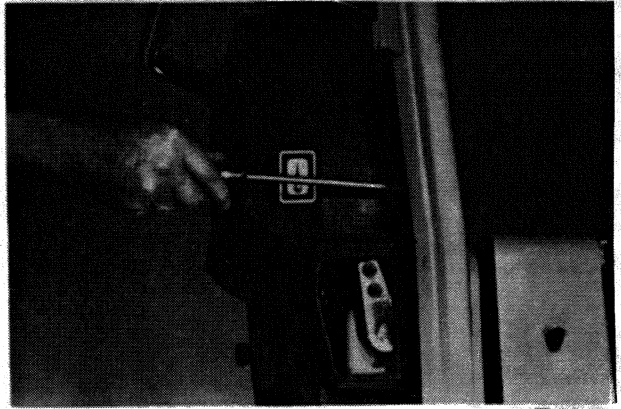

8.3.3.6.4

Remove four (4) retaining screws holding instrument panel to cover.

T-93476

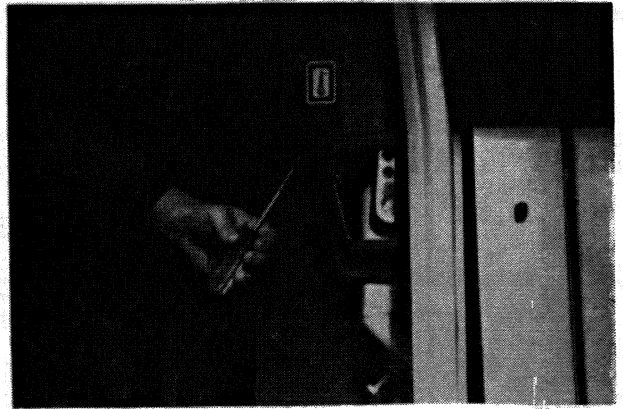

8.2.2.6.5

Remove instrument panel from cover.

T-93477



8.3.3.6.6

Remove one (1) retaining capscrew from inside center of cover.

T-93478



Study SAFETY RULES in the front of this manual thoroughly for the protection of machine and safety of personnel.

8.3 REPAIR PROCEDURES

CAB GLASS DIMENSION

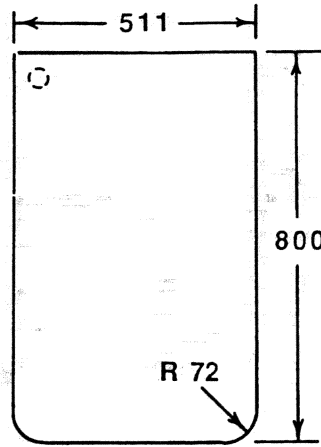

FRONT WINDOW

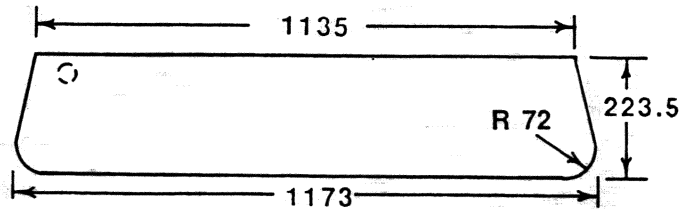

REAR UPPER WINDOW

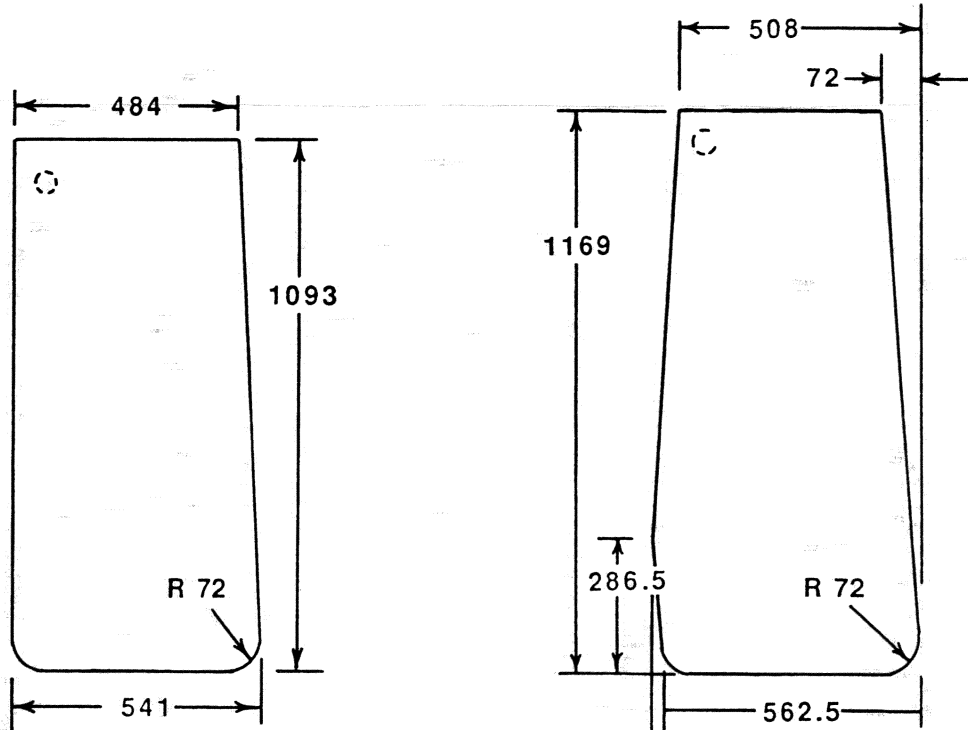

SIDE WINDOW

DOOR WINDOW

T-100572

NOTE: See preceding page for thickness of glass and metric to inches conversion.

Study SAFETY RULES in the front of this manual thoroughly for the protection of machine and safety of personnel.

8.3 REPAIR PROCEDURES

8.3.3.10 REFERENCE DRAWING

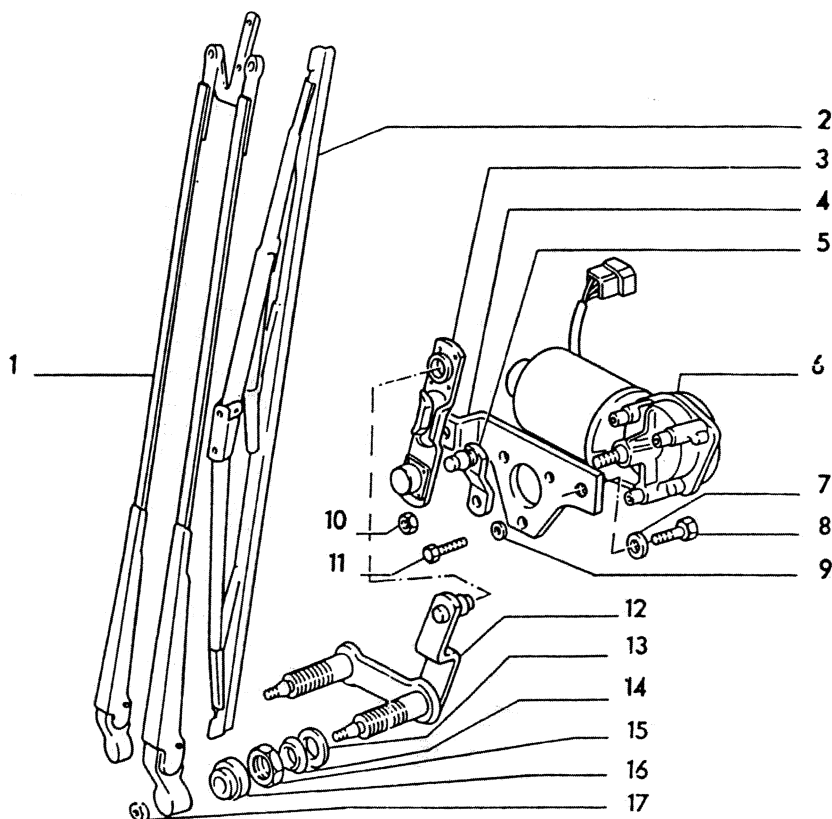

T-100581

FRONT WINDSHIELD WIPER

- | | | |
|---------------------|--------------|------------------|
| 1. Wiper Arm | 7. Washer | 12. Pin Assembly |
| 2. Wiper Blade | 8. Capscrew | 13. Gasket |
| 3. Link Rod | 9. Washer | 14. Spacer |
| 4. Mounting Bracket | 10. Nut | 15. Nut |
| 5. Bell Crank | 11. Capscrew | 16. Boot |
| 6. Wiper Motor | | 17. Nut |

Study SAFETY RULES in the front of this manual thoroughly for the protection of machine and safety of personnel.

CLICK HERE TO **DOWNLOAD** THE COMPLETE MANUAL

- Thank you very much for reading the preview of the manual.
- You can download the complete manual from: www.heydownloads.com by clicking the link below



- Please note: If there is no response to CLICKING the link, please download this PDF first and then click on it.

CLICK HERE TO **DOWNLOAD** THE COMPLETE MANUAL