



Service Manual

W170/170PL-W190

CLICK HERE TO **DOWNLOAD** THE COMPLETE MANUAL

- Thank you very much for reading the preview of the manual.
- You can download the complete manual from: www.heydownloads.com by clicking the link below



- Please note: If there is no response to CLICKING the link, please download this PDF first and then click on it.

CLICK HERE TO **DOWNLOAD** THE COMPLETE MANUAL

SAFETY RULES

DECOMMISSIONING THE MACHINE

For the decommissioning of the machine, the availability of particular tooling (hoists, hydraulic presses, containers for liquids etc.) is required as well as specific tools listed in the Repair Manuals, available from **FIAT-HITACHI** Dealers.

This has the purpose of avoiding that during disassembly operations, dangerous situations may arise both for the personnel involved and the environment.

In the machine are present:

- Fluids under pressure (hydraulic system, cooling system etc.)
- Gases (air conditioning system and accumulator, if installed)
- Mechanical devices mounted under pressure (track tensioner etc.)
- Heavy machine components (frames, blades, buckets etc.)

**WARNING**

- The decommissioning of the machine must be performed exclusively by personnel trained, qualified and authorised to perform such operation.
- Start the disassembly of hydraulic components only after the same, the hydraulic oil and lubricants have fully cooled-off and after all residual pressures have been released, as described by the Repair Instruction Manual.
- Prior to proceeding with disassembly operations, comply with the **GENERAL SAFETY RULES** and drain each components of the machine filled with fluids, both in the reservoirs and the relevant systems.

**WARNING**

Ensure that the attachment is safely resting on to the ground before repairing, adjusting, or servicing machines fitted with hydraulically, mechanically or cable controlled attachments (such as excavators, loaders, dozers, scrapers, etc.). Should it be necessary to partially or fully raise the hydraulically, mechanically, or cable controlled attachment to gain access to certain items, make sure the attachment is adequately retained in the raised position by means other than the hydraulic lift cylinders, cable and/or mechanical devices used for controlling it.

NUTS (ZNT)					SCREWS (ZNT/DEIDR)		
Strength grade: 10 (R80)					Strength grade: 10.9 (R100)		
Diameter and pitch mm	normal	low type	with polyamide ring		Diameter and pitch mm	normal ZNT daNm	self-locking ZNT daNm
	daNm	daNm	normal daNm	low type daNm			
M6 x 1	1.3	1.2	-	-	M6 x 1	1.3	-
M8 x 1.25	3.2	2.6	3.9	3.2	M8 x 1.25	1.3	3.5
M10 x 1.25	7.2	5.2	8.2	6.2	M10 x 1.25	7.1	7.9
M10 x 1.5	6.5	5	7.7	6	M10 x 1.5	6.5	7
M12 x 1.25	13	8.7	14.5	10.2	M12 x 1.25	12.7	13.9
M12 x 1.75	11	8.1	12.9	9.6	M12 x 1.75	11	12
M14 x 1.5	19.5	13	21.6	15	M14 x 1.5	20	22
M14 x 2	18	12.5	20	14.6	M14 x 2	18	19
M16 x 1.5	30	17	34	20	M16 x 1.5	30	33
M16 x 2	-	-	-	-	M16 x 2	-	-
M18 x 1.5	45	25	50	29	M18 x 1.5	45	48
M18 x 2.5	-	-	-	-	M18 x 2.5	-	-
M20 x 1.5	60	30.5	64.5	35	M20 x 1.5	60	65
M20 x 2.5	-	-	-	-	M20 x 2.5	-	-
M22 x 1.5	80	41	-	-	M22 x 1.5	80	90
M22 x 2.5	-	-	-	-	M22 x 2.5	-	-
M24 x 2	100	47	108	52.5	M24 x 2	100	110
M24 x 3	-	-	-	-	M24 x 3	-	-
M27 x 2	95	40.1	-	-	M27 x 2	100	-
M30 x 2	130	49.4	-	-	M30 x 2	140	-
M33 x 2	170	-	-	-	M33 x 2	190	-
M36 x 3	220	-	-	-	M36 x 3	240	-

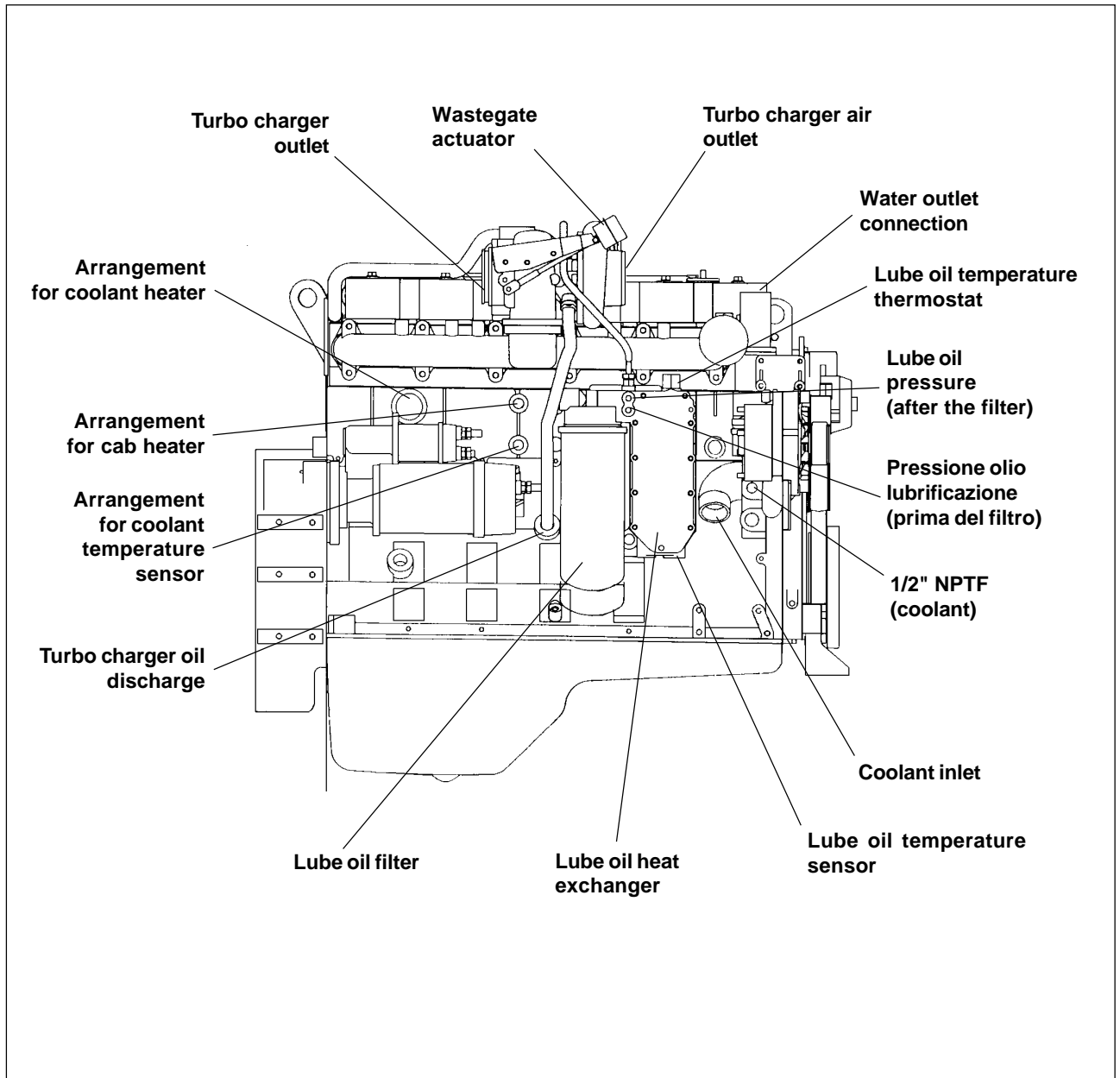
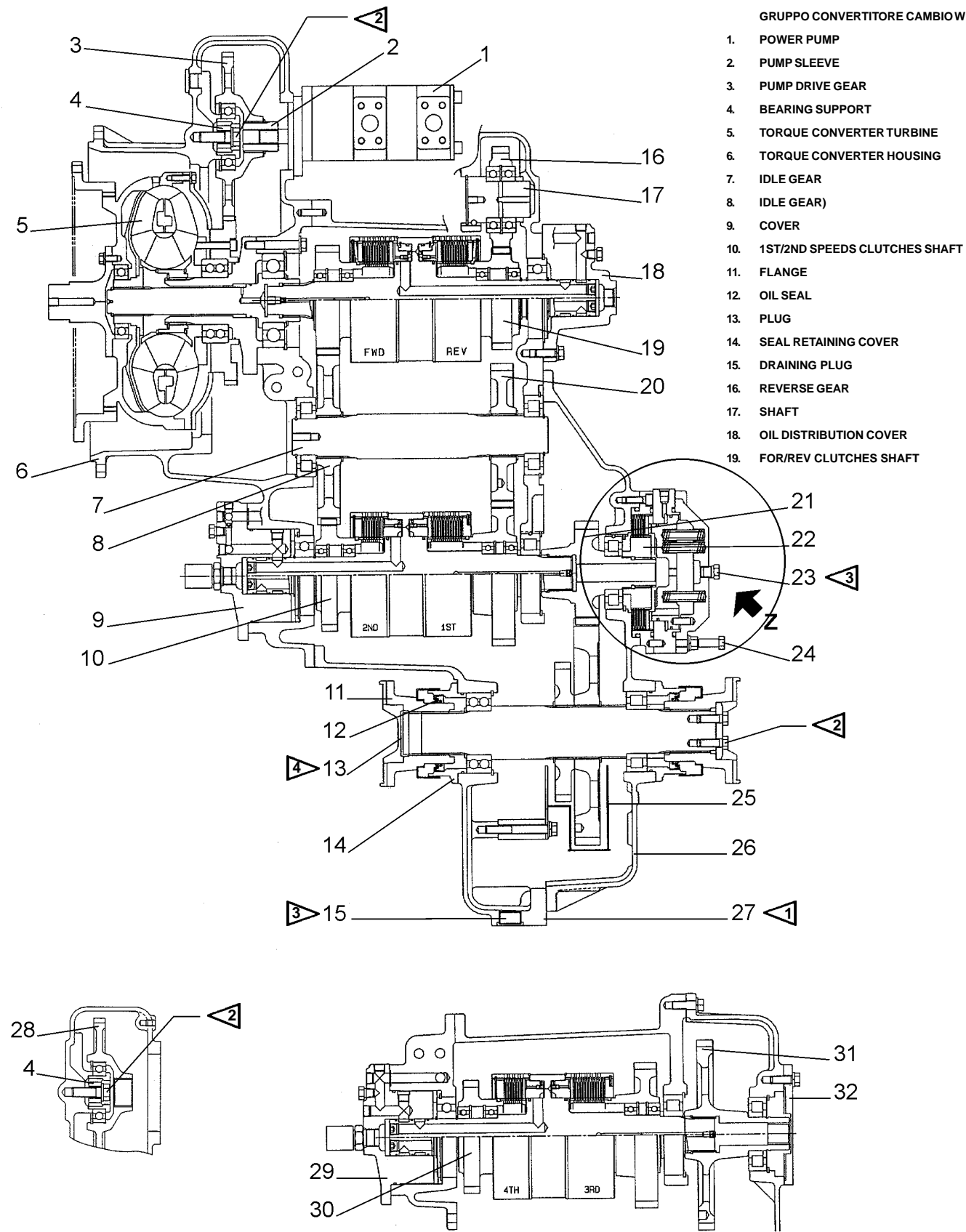

Fig. 1-11 View of turbocharger side



- GRUPPO CONVERTITORE CAMBIO W170**
- 1. POWER PUMP
 - 2. PUMP SLEEVE
 - 3. PUMP DRIVE GEAR
 - 4. BEARING SUPPORT
 - 5. TORQUE CONVERTER TURBINE
 - 6. TORQUE CONVERTER HOUSING
 - 7. IDLE GEAR
 - 8. IDLE GEAR)
 - 9. COVER
 - 10. 1ST/2ND SPEEDS CLUTCHES SHAFT
 - 11. FLANGE
 - 12. OIL SEAL
 - 13. PLUG
 - 14. SEAL RETAINING COVER
 - 15. DRAINING PLUG
 - 16. REVERSE GEAR
 - 17. SHAFT
 - 18. OIL DISTRIBUTION COVER
 - 19. FOR/REV CLUTCHES SHAFT

- 20. GEAR
- 21. 1ST/2ND SPEEDS GEAR
- 22. PARKING BRAKE DISC HUB
- 23. PLUG
- 24. PARKING BRAKE RELEASE SCREW
- 25. OIL BAFFLE
- 26. REAR TRANSMISSION HOUSING
- 27. TRANSMISSION HOUSING
- 28. GEAR
- 29. OIL CONTROL VALVE
- 30. 3RD/4TH SPEEDS CLUTCHES SHAFT
- 31. 5TH/4TH SPEEDS GEAR
- 32. PLATE
- 33. SPEED SENSOR (FOR SPEEDOMETER)
- 34. PISTON MOUNTING
- 35. BRAKE MOUNTING
- 36. INNER TOOTHED DISCS
- 37. OUTER TOOTHED DISCS
- 38. COVER
- 39. PISTON
- 40. SPRING
- 41. FINAL DISC HOLDING PLATE

- Note -**
- 1 Torque converter housing connection flange : LOCTITE FMD-127
 - 2 Threaded part: LOCTITE 262
 - 3 Threaded part: LOCTITE 572
 - 4 Outer diameter: LOCTITE 572
 - 5 Setting of gap E: after bringing the sensor against the gear, move it away, by loosening it, 1.5 turn.

Note - procedure for the installation of seals

- Seal outer diameter (metal): LOCTITE 262
- Seal lip: Grease
- Bevel and sliding surface of connection flanges: Grease

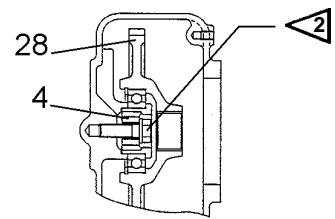

Section J-J

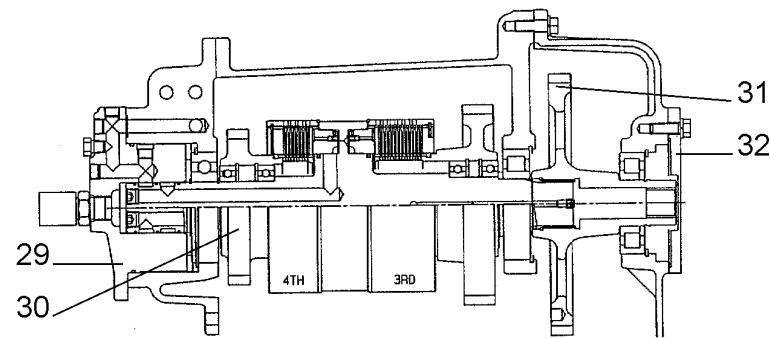

Section E-E

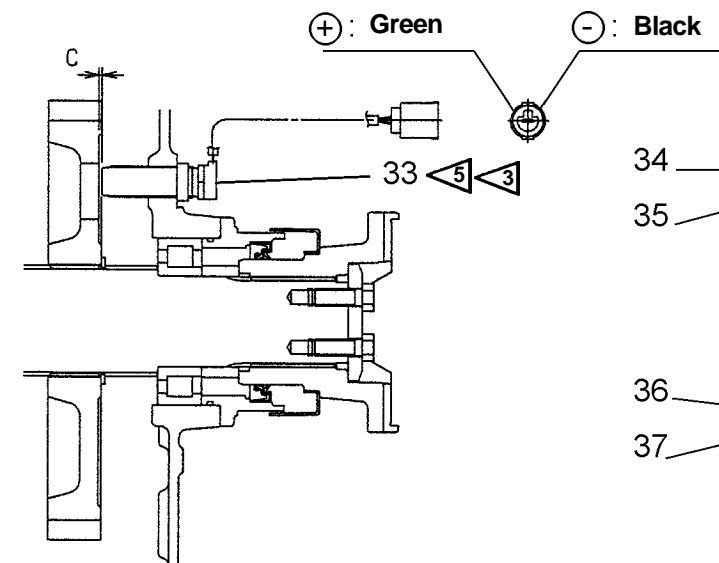

Section D-D

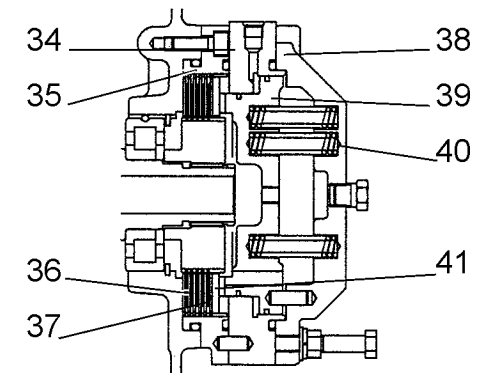

Detail area Z

Fig. 2-7 Transmission - torque converter group of model W190 (2)

OPERATION

The clutch is engaged by the oil under pressure flowing from the transmission control valve. Pressurized oil flows through the distribution cover and the ducts in the clutch shaft reaching the rear side of the clutch piston, moving it.

Then the clutch piston compresses the outer and inner disc fully, thus holding the clutch shaft with the clutch hub, allowing the driving of the power through the output shaft of the transmission.

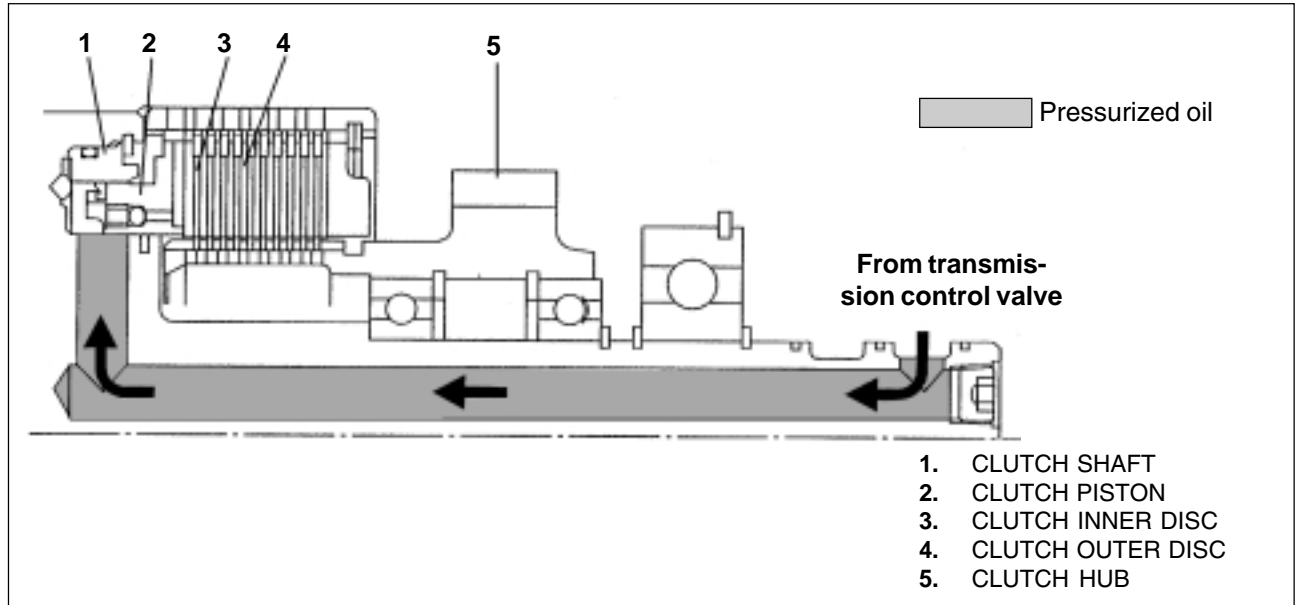

Fig. 2-17 Clutch engagement

When pressurized oil from the control valve is cut-off, the return spring moves the clutch piston backward, freeing the clutch inner and outer disc pack, allowing

the clutch shaft and the clutch hub to rotate independently, thus avoiding the transmission of power to the output shaft of the transmission.

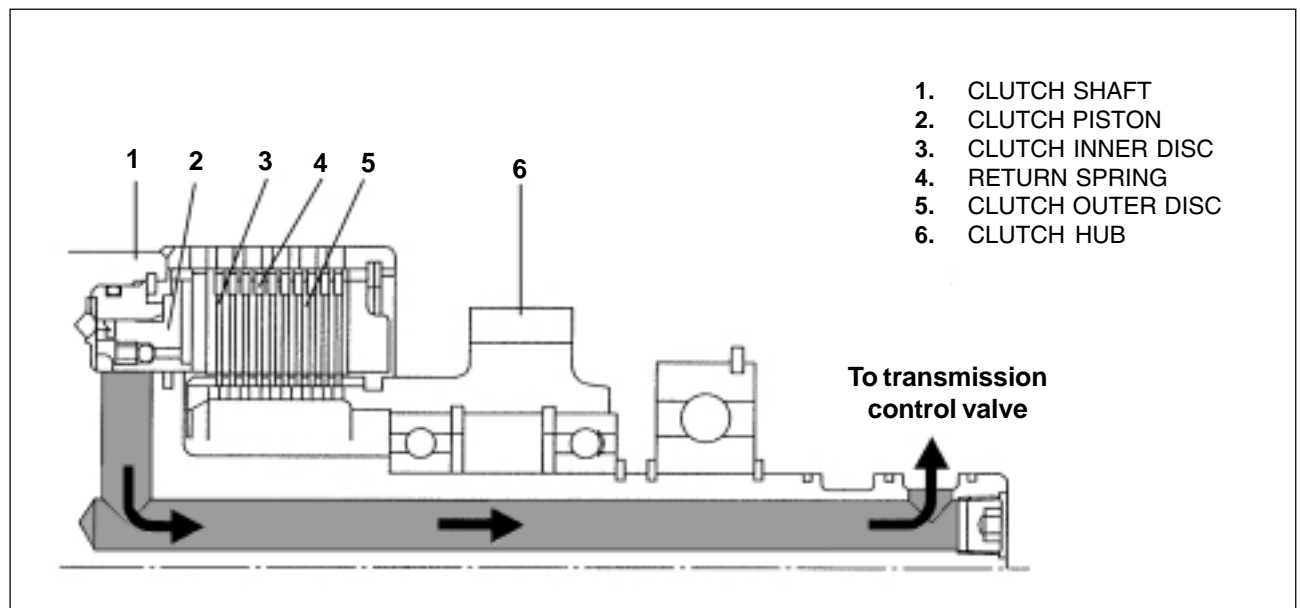

Fig. 2-18 Clutch disengagement

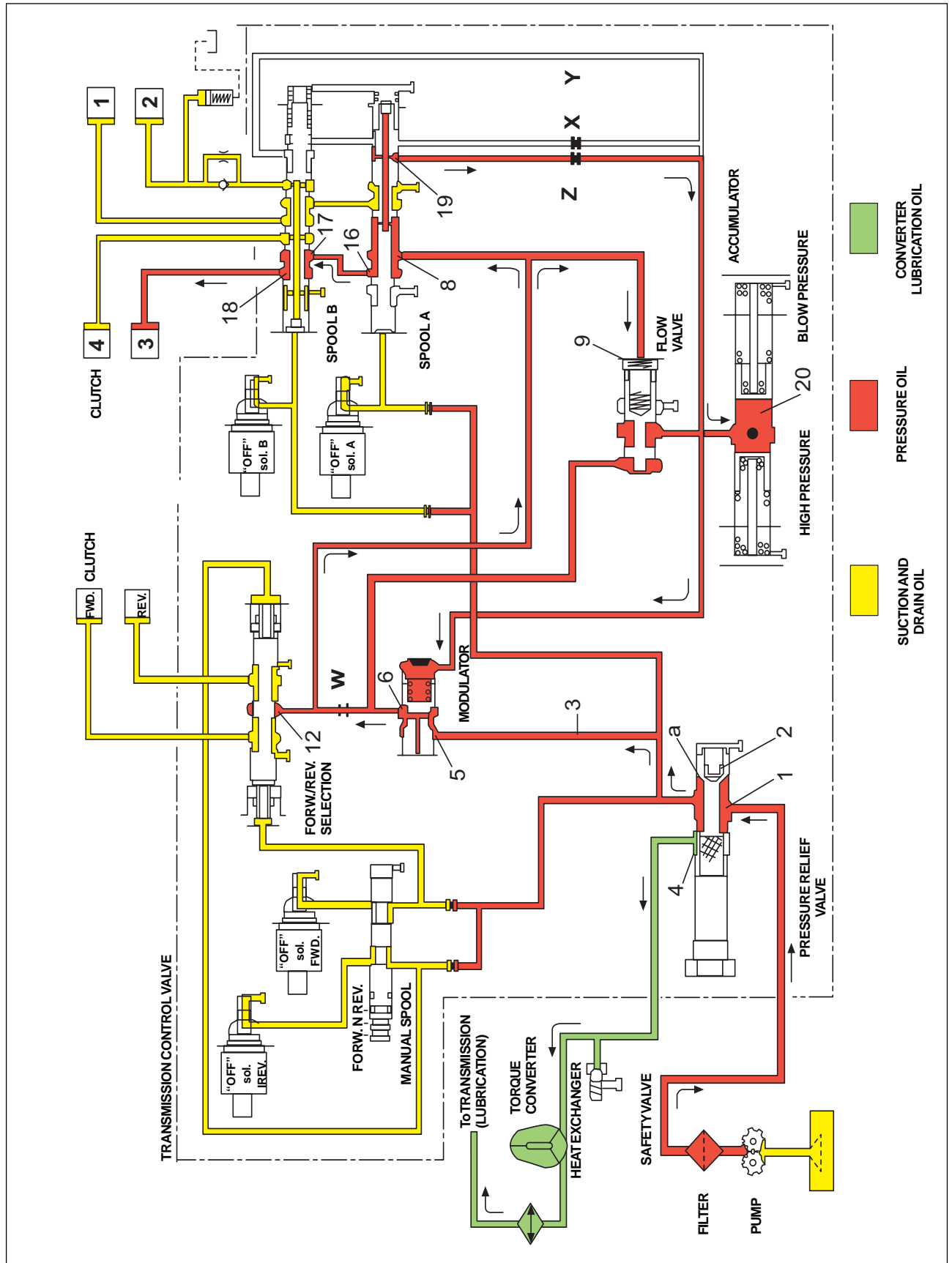

Fig. 2-28 3rd speed in Neutral

**Operation of manual spool
(emergency travel)**

Should the solenoid valves fail to operate correctly due to a cut-off electrical connection or any other electrical fault, it is possible to actuate the transmission control valve in 3rd forward or reverse, using this spool. It is recommended that this spool is used when the loader has to be moved away from a traffic area or to be repaired.



WARNING

Ensure that the engine is not running prior to operate the manual spool. Should the spool actuated when the engine is running, the loader could move suddenly, causing accidents.

goes through the orifices and reaches the circuits of the manual spool (31, 32). Since circuit (31) is blocked by the spool, the oil is diverted from circuit (33) into circuit (26) of the FORW./REV. selector spool, moving it rightward, as indicated in the figure, so that the oil pressure in the FORW. clutch increases.

2. The oil of circuit (32) goes through the spool and the REV. solenoid valve to be discharged.
3. Being both solenoid valves A and B of the gear-shift spools not energized, the pressure in the 3rd speed clutch increases (refer to Fig. 2-24). Consequently, the loader will travel in 3rd forward.

a. Transmission in 3rd Forward

To shift into 3rd forward, pull-out the manual spool about 10 mm (0.39 in).

1. The oil, at the pressure set by the relief valve,

b. Transmission in 3rd reverse

To shift into 3rd reverse, push-in the manual spool about 10 mm (0.39 in).

The operation principle is the same as in the case of 3rd forward.

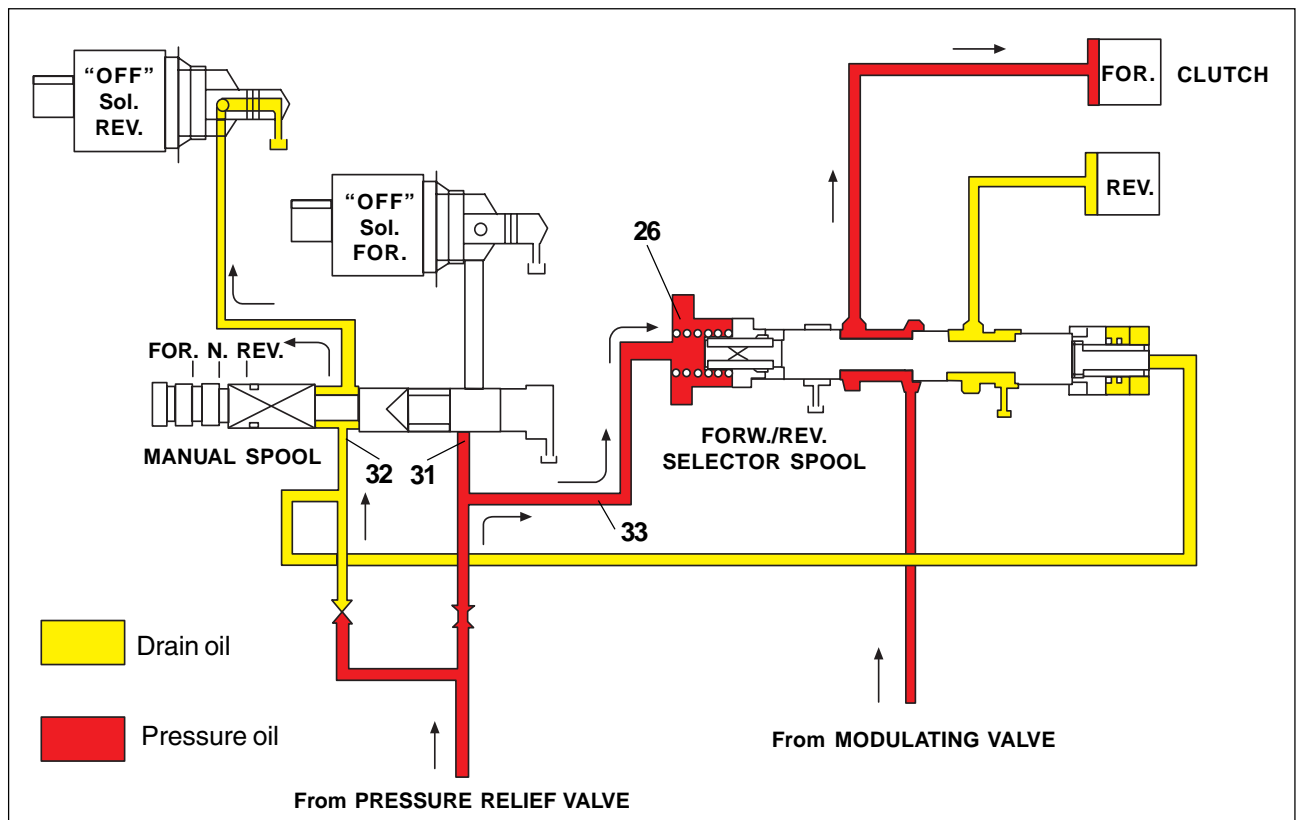

Fig. 2-36 Engaged forward gear by means of manuals spool

- At the same time, power "f" appears, allowing relay 2 to remain self energized, thus it stays activated also after the Kick-Down button device is released. Consequently, the transmission stays in 1st speed after the Kick-Down device is de-activated.

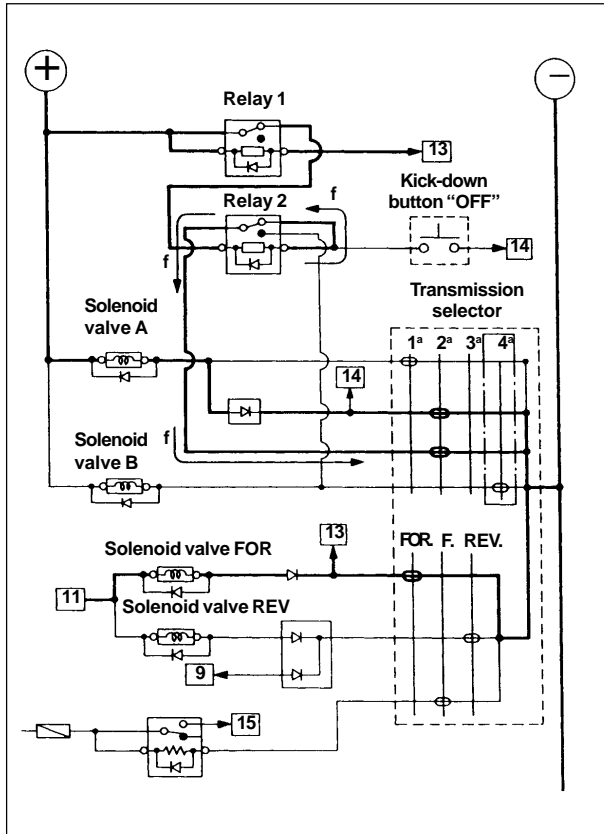

Fig. 2-46

Transmission in reverse direction

- When the gearshift lever is moved to reverse, power "b" is zeroed, thus relay 1 is de-activated. This causes the cut-off of power "f" at relay 2 causing also the opening of relay 2.
- Power "d" energizing solenoid valve B is re-established, thus shifting into 2nd speed.
- Also, solenoid valve "REV." is energized by power "g" to engage the transmission in 2nd reverse.

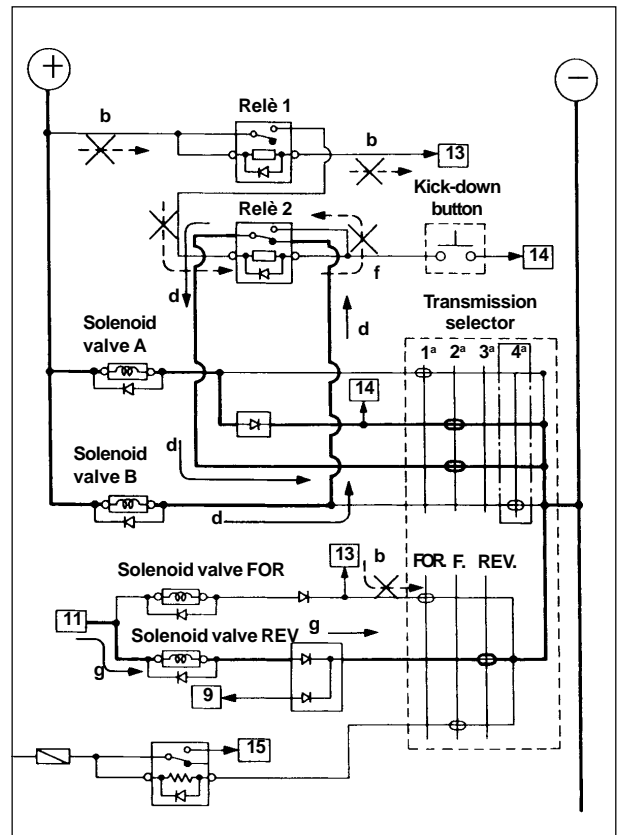

Fig. 2-47

11. Lift and remove the cover wheel. The turbine wheel can be removed at the same time. Remove the O-ring at the mating surface.

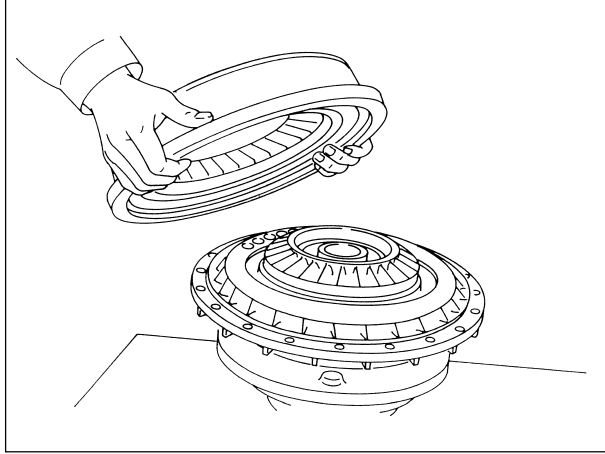

Fig. 2-74

13. Push the front end of the guide carrier (stator support) with a press and push the guide carrier out. Remove the seal ring from the guide carrier.

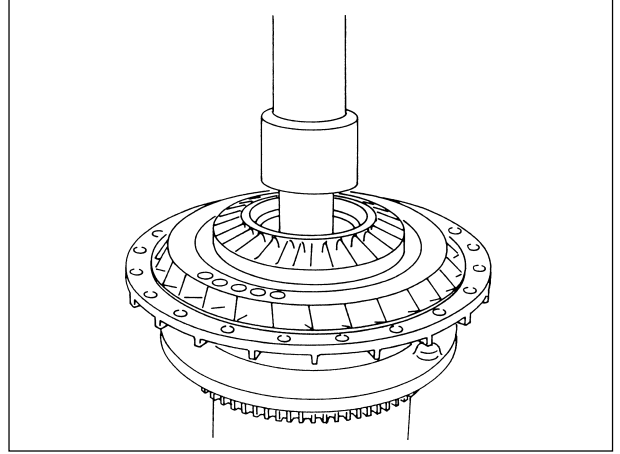

Fig. 2-76

12. Remove the snap ring from the shaft of the stator wheel hub.

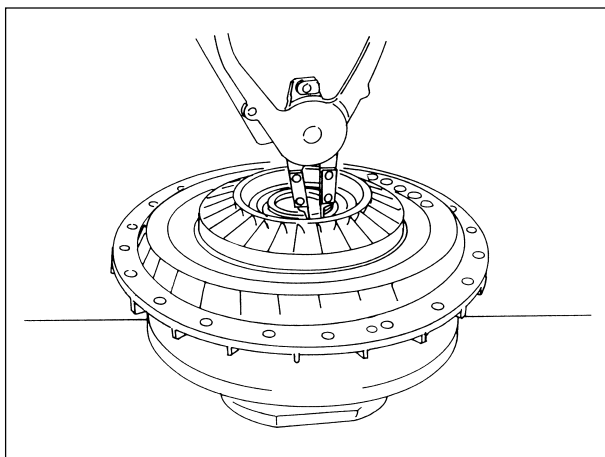

Fig. 2-75

14. Remove the stator wheel and the spacer in this order.

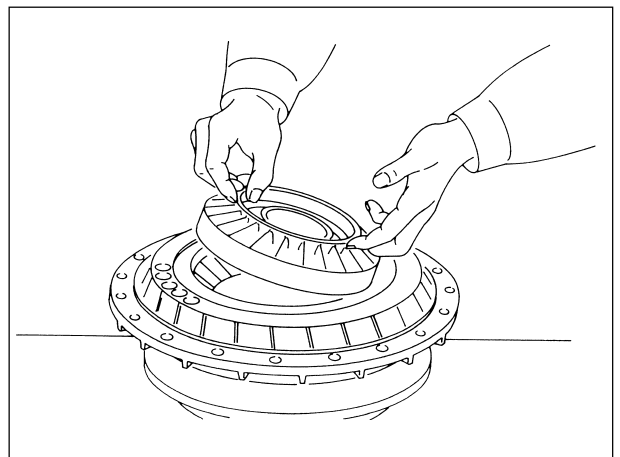

Fig. 2-77

3. Remove the back gear.

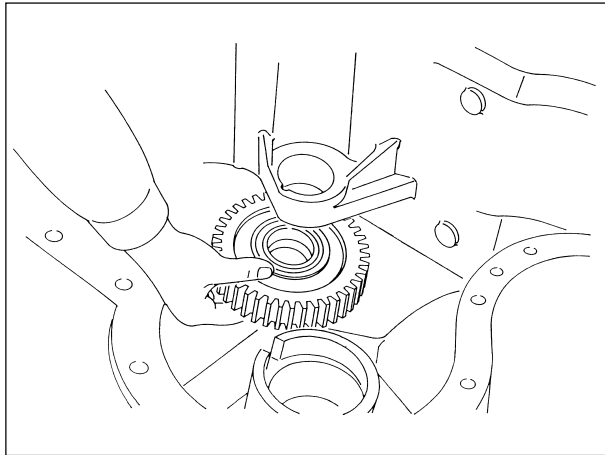

Fig. 2-114

5. Remove the two bearings and the snap ring from inside the back gear.

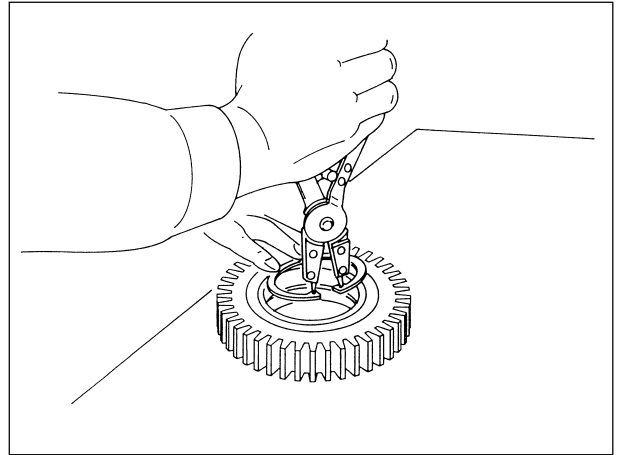

Fig. 2-116

4. Remove the spacer from the case side.

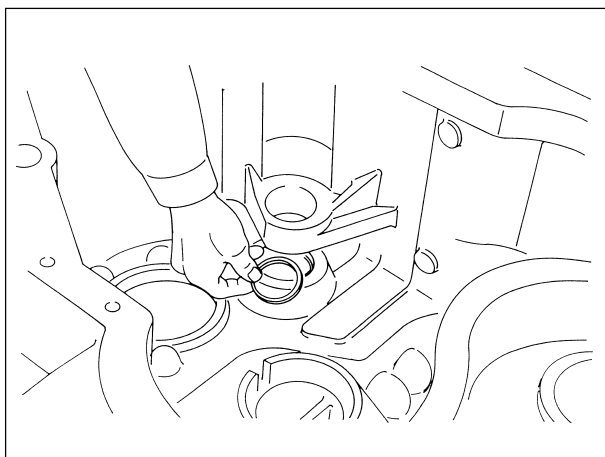

Fig. 2-115

n) Disassembling Forward/Reverse Clutch Shaft

1. Hold the clutch shaft upright with the forward clutch (the side having spline shaft) pointed upward.
2. Remove the snap ring from the shaft groove.

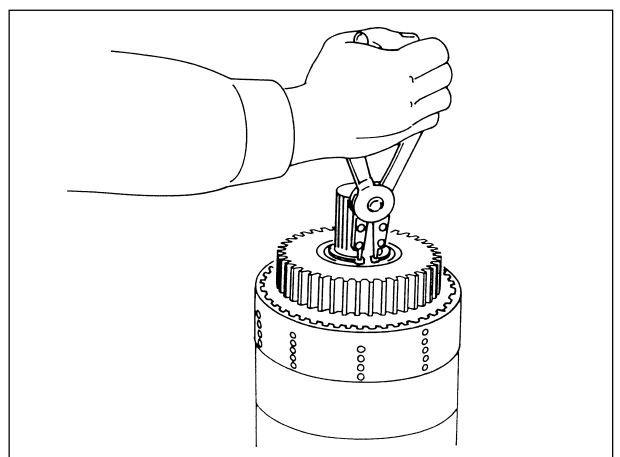

Fig. 2-117

3. Install the pump drive gear in the pump drive sleeve and secure with the snap ring.

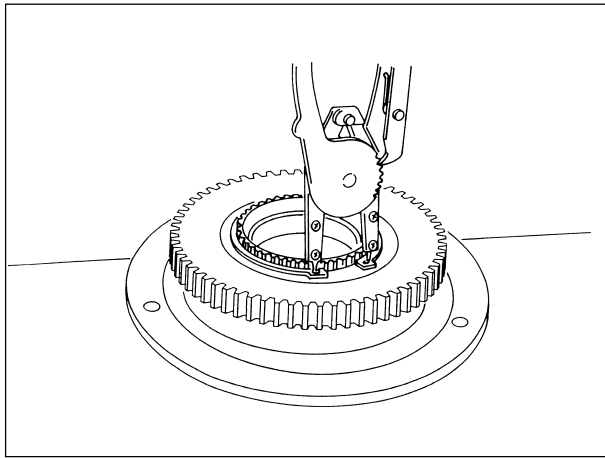

Fig. 2-152

5. Apply grease to the O-ring and install it in the pump drive sleeve groove.

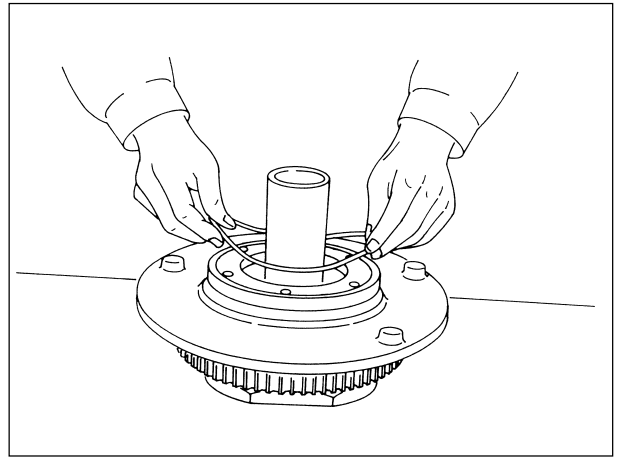

Fig. 2-154

4. Apply converter oil to the seal ring and install the seal ring in the guide carrier (stator support). Install the reassembled pump drive sleeve on the guide carrier.

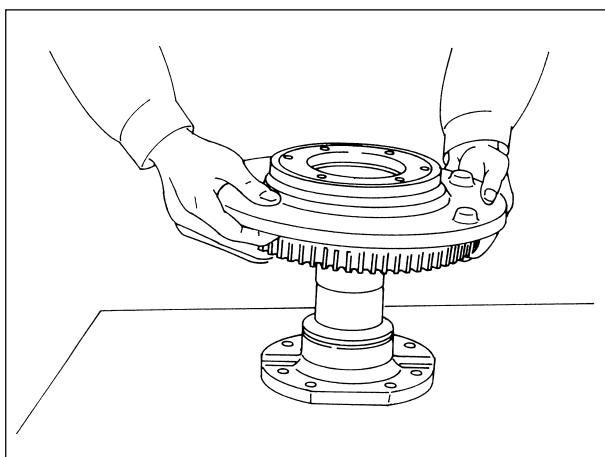

Fig. 2-1531

6. Place the impeller wheel on the pump drive sleeve.

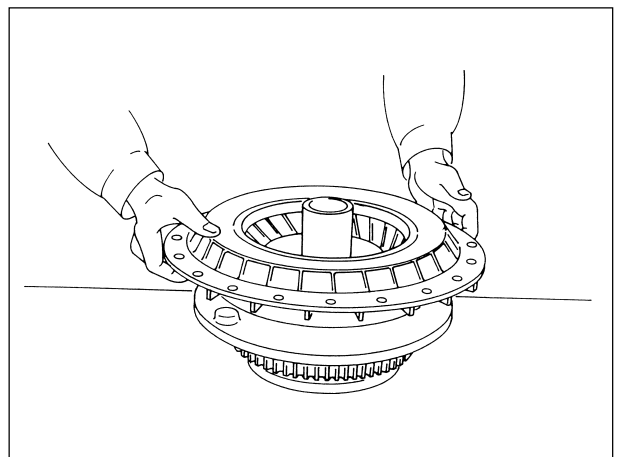

Fig. 2-155

8. Install the snap ring, the bearing and the snap ring onto the shaft in this order, with the snap ring groove in the bearing outer diameter pointed to the outside.
9. Turn the clutch shaft upside down and reassemble the 4th clutch using the same procedure as reassembling the forward clutch.

Reassembling 1st/2nd Shaft

Reassemble the 1st/2nd shaft, referring to "b) Reassembling 3rd/4th Shaft".

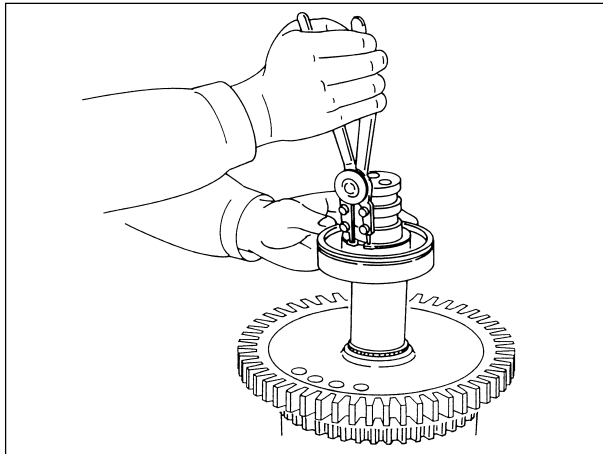

Fig. 2-192

plugs at the top, before installing them on the valve body securely. Use caution not to install the plugs in the wrong bores.

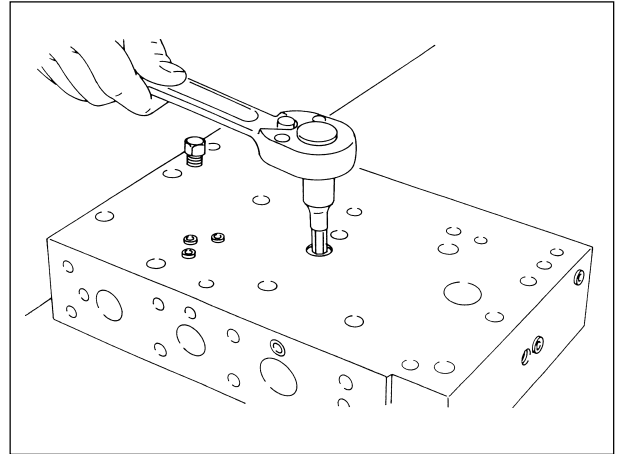

Fig. 2-193

g) Reassembling control valve

Cautions to be taken when reassembling the control valve.

Wash all disassembled parts thoroughly and dry them by blowing air. Do not wipe them with waste cloth or paper; otherwise dirt might gather the parts, causing a trouble in the hydraulic circuit. Check the passages and the orifices of the spools for clogging. If any clogging is found, remove and wash. Apply LOCTITE 572 to the threaded area of plugs which do not use O-rings, before installing them.

Do not use the seal tape because it might cause clogging.

1. Apply LOCTITE 572 to the threaded area of the four throttle plugs at the side and the four throttle

2. Install the spring (3), adapter (2) and forward/reverse selection spool (1) into the spool hole of the eight-bolt cover. Install the selection spring (5) and spool A (4) into the center spool hole. Install the selection spring (5) and spool B (6) into the other spool hole.

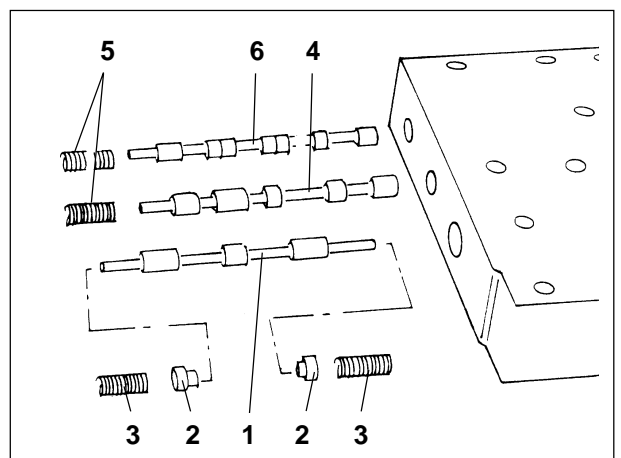

Fig. 2-194

8. Hold the transmission case upright and install the snap ring in the rear bearing outer diameter groove of each of three clutch shafts.

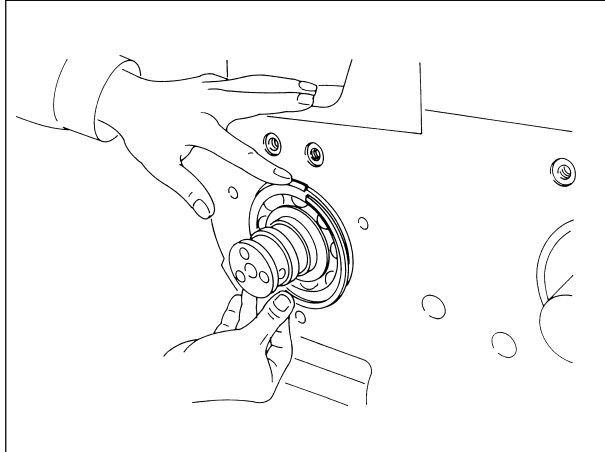

Fig. 2-231

n) Installing Distributor Cap and Piping

1. Put two O-rings and a gasket on each distributor cap mounting surface of the three clutch shafts. Place the distributor caps over the O-rings and the gaskets and secure each of them with three bolts. Tightening torque: 1.9 kgm.

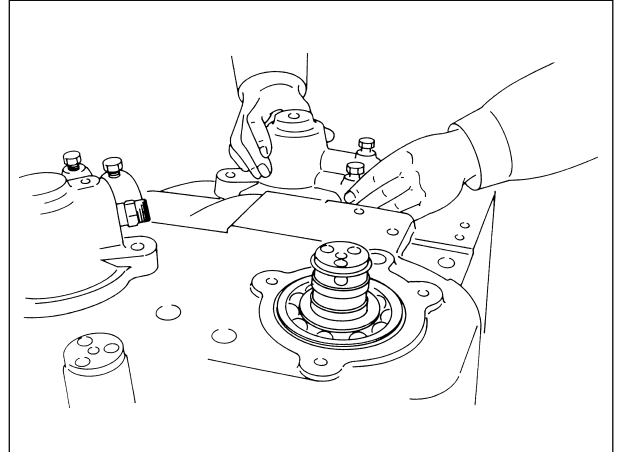

Fig. 2-233

9. Apply converter oil to seal rings and install three seal rings in each of three clutch shafts.

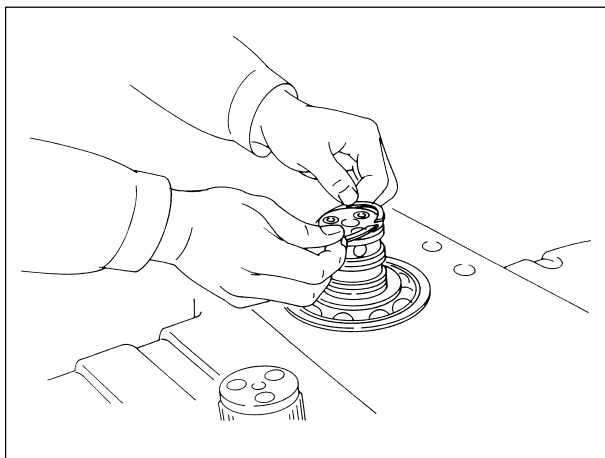

Fig. 2-232

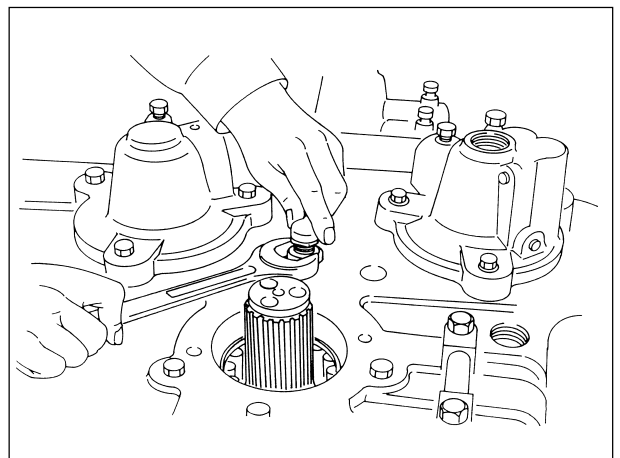

Fig. 2-234

2. Apply LOCTITE 572 to the threaded area of the rotation sensor and screw the sensor into the case. After screwing the sensor all the way against the output gear, back off the sensor 1.5 turns. Secure the sensor with the lock nut.

d) Removing converter housing

1. Temporarily lift the converter housing and the 30 bolts attaching the transmission case.

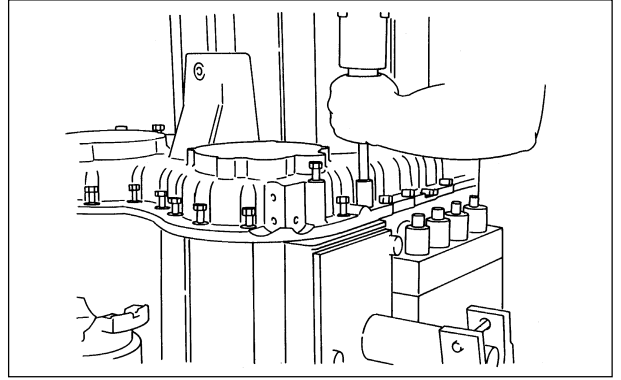

Fig. 2-269

2. Suspending the mating surface with 2 punched bolts and checking the housing is removed smoothly, lift the converter housing little by little with a hoist.

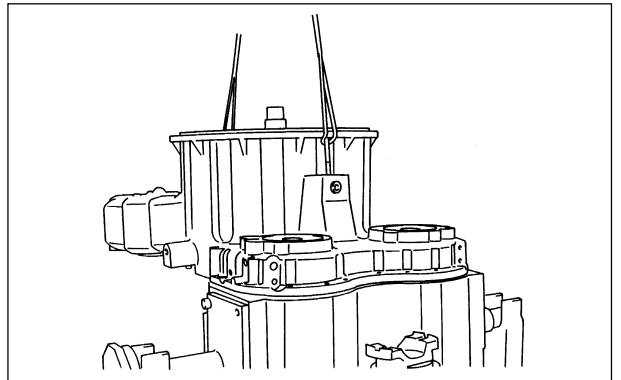

Fig. 2-270

e) Removing converter wheel

1. Turn the converter housing upside down with converter wheel downward and remove the 9 bolts securing the stator support.

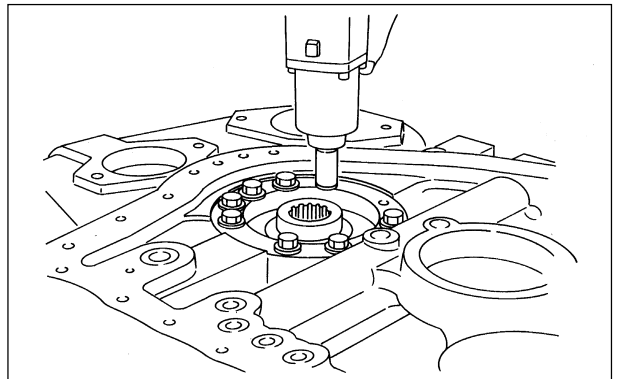

Fig. 2-271

2. Turn the converter housing upside down again with converter wheel upward.
3. Attach a hanger to the input guide and lift it gently to remove. If it is too hard to remove, use a soft hammer.

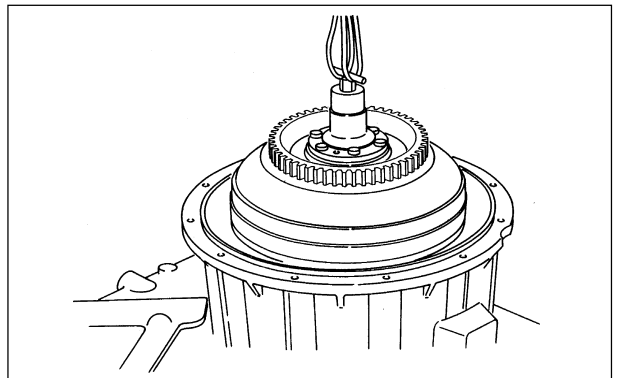

Fig. 2-272

3. Remove the snap ring from the case groove next to the 3rd/4th speed shaft bearing.

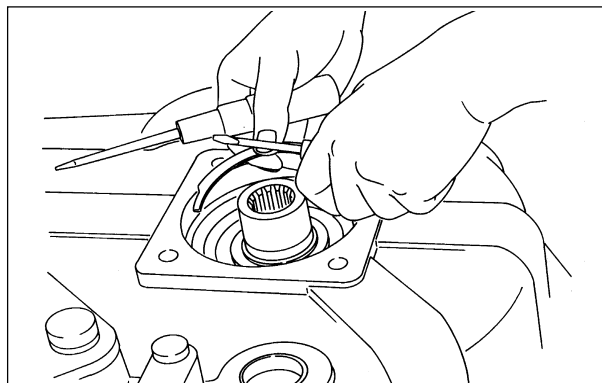

Fig. 2-308

4. Remove the 4 bolts securing the flange and detach the flange, retainer plate and "O"-ring.

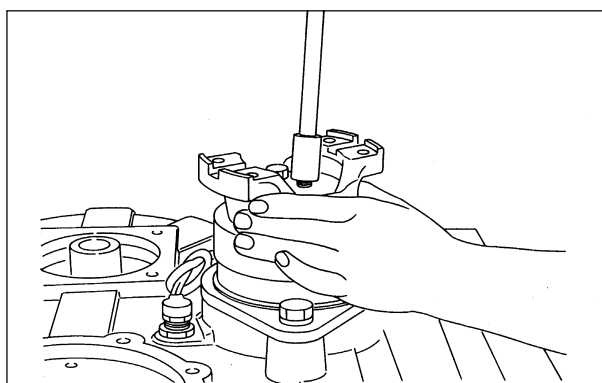

Fig. 2-309

5. Remove the 2 bolts securing the seal retainer and detach the seal retainer. If it is too hard to remove, rise it using a bar.
6. Remove the "O"-ring and oil seal from the seal retainer.

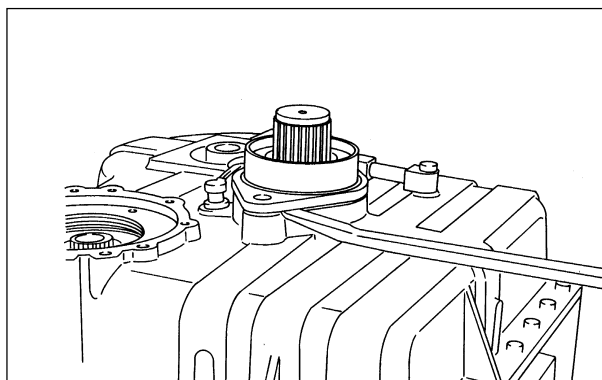

Fig. 2-310

7. Remove the spacer from the output shaft.

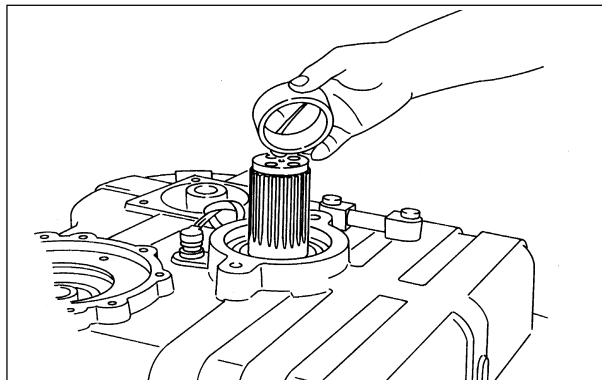
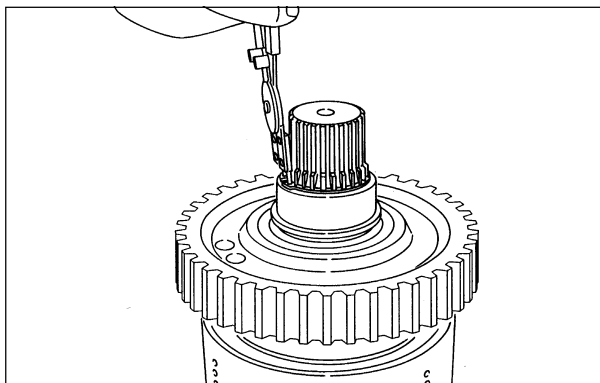

Fig. 2-311

q) Disassembling 3rd/4th speed clutch shaft

1. Put the shaft with the 3rd speed clutch (spline shaft side) upward and secure it.
2. Remove the snap ring securing the roller bearing inner race. Using a puller, remove the inner race and the spacer.

**Fig. 2-344**

3. For the disassembly procedure, refer to the step (4) to (10) of "(1) Disassembling forward/reverse clutch shaft".
4. Disassemble the 4th speed clutch shaft on the other end in the same manner as for the 3rd speed clutch shaft.

r) Disassembling 1st/2nd speed clutch shaft

For the disassembly procedure, refer to "(2) Disassembling 3rd/4th speed clutch shaft".

7. Finally put the end plate and belleville spring, and press it to compress the return spring until the snap ring groove inside the drum comes into view.

Note - Put the belleville spring with its concave side pointed upward.

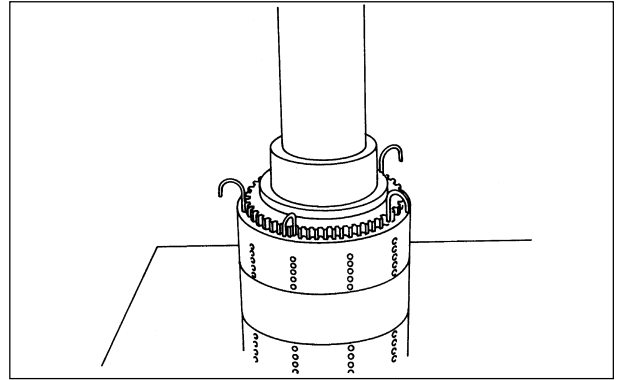

Fig. 2-378

8. Remove all the rod jigs and attach the snap ring into the groove in the drum.

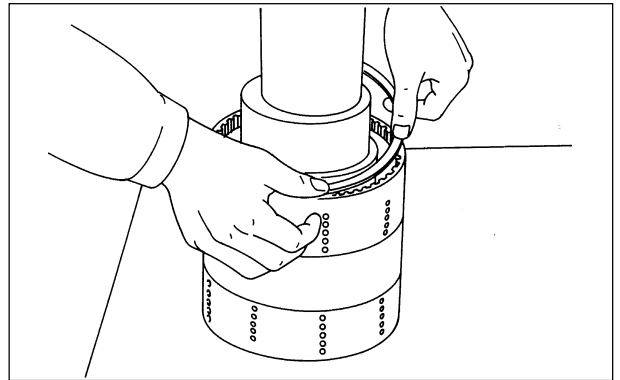

Fig. 2-379

9. Fit the hub gear ball bearing (inner) onto the clutch shaft.

Note - Remember that the inner bearing does not have a shield.

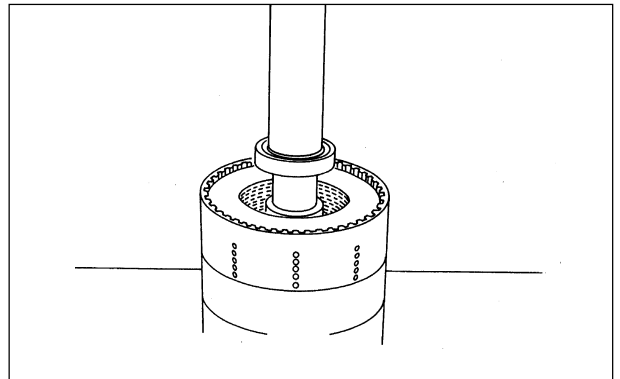

Fig. 2-380

10. Make sure the 2 snap rings are installed inside the hub gear.

11. Install the hub gear inside the clutch drum, turning it to the right and left by hand to align the gear teeth with the disk splines.

Fit the hub gear onto the shaft with a soft hammer until it comes in contact with the bearing on the shaft.

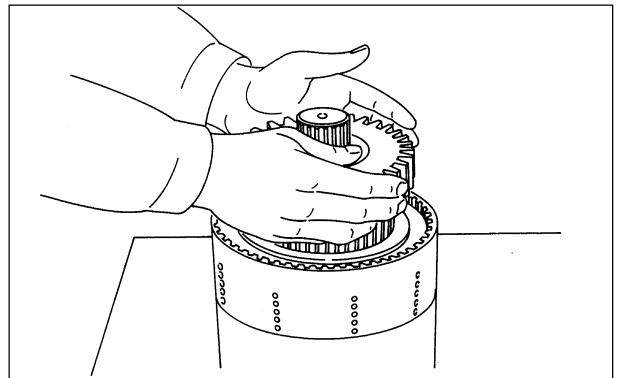

Fig. 2-381

10. Install the snap ring into the groove at the outer diameter of the bearing on the idler shaft.

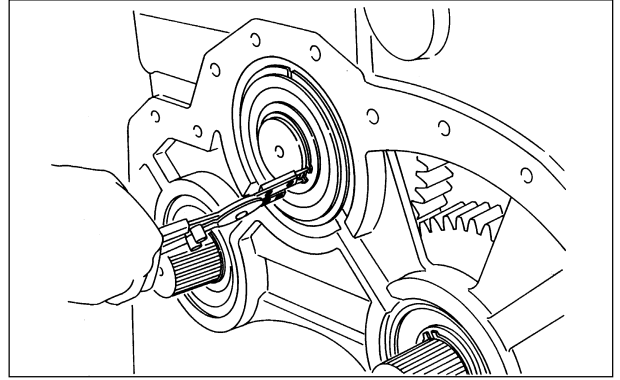

Fig. 2-412

11. Install the locks onto the 1st/2nd a 3rd/4th speed shaft not to drop them.

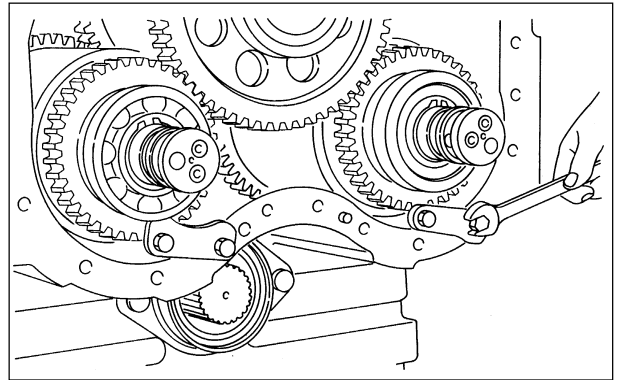

Fig. 2-413

12. Put the transmission case with its converter side pointed downward.
13. Install the snap ring onto the output shaft. Install the 47T gear into the spline.

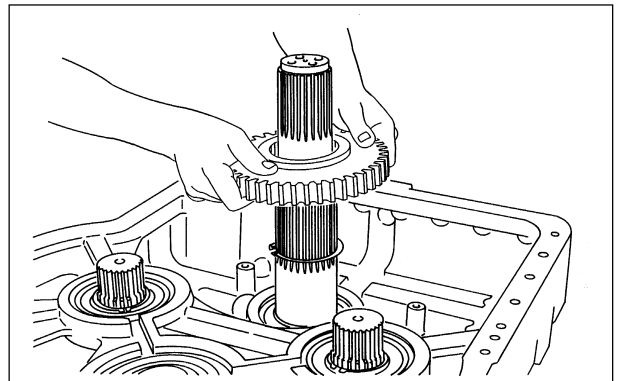

Fig. 2-414

14. Press the roller bearing into the high gear and secure it with a snap ring.
15. Install the assembled high gear into the spline on the 3rd/4th speed shaft, engaging it with the output gear.

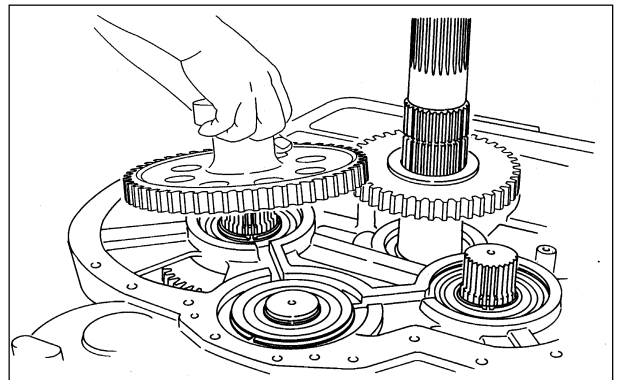

Fig. 2-415

2. Put the transmission assembly upright.
3. Install the drive sleeve into the pump drive gear and install the charging pump onto the converter housing. Tighten the 2 bolts securing the pump.

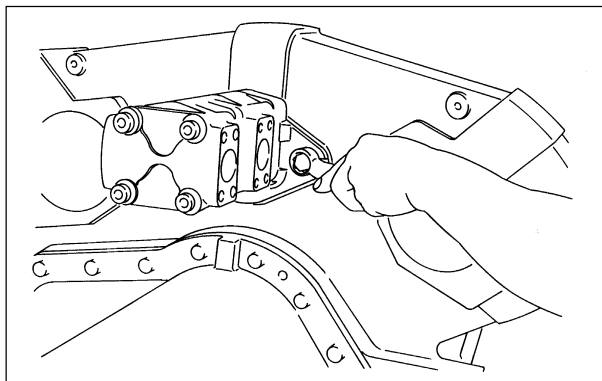

Fig. 2-452

4. Install the cap assembly (the 1st/2nd speed distributor cap) in the same manner.

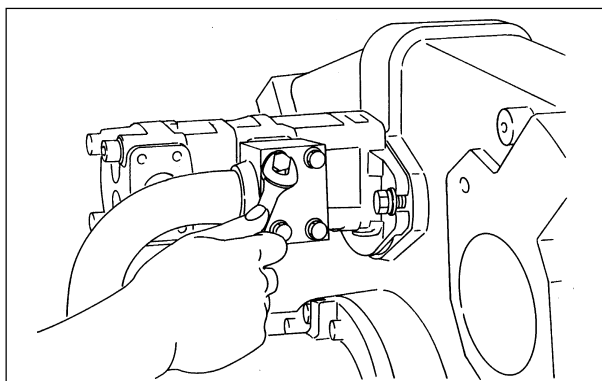

Fig. 2-453

t) Reinstalling control valve

1. With a new gasket, install the control valve (lower section) onto the transmission case with 3 bolts.

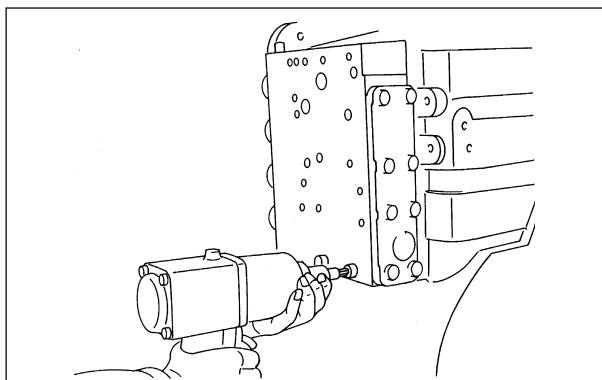

Fig. 2-454

2. With a new gasket, install the control valve (upper section) onto the control valve (lower section) with 11 bolts.

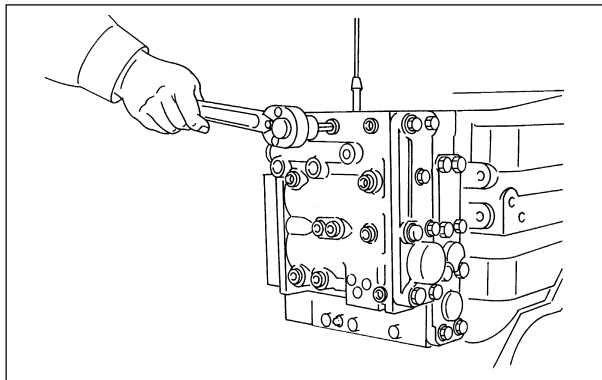

Fig. 2-455

2.14 PROP SHAFTS

The prop-shafts transfer the power of the transmission to the front and rear axles.

The prop-shaft connected to the front axle is equipped with an intermediate support, secured to the front frame, as a stopping element, since the loader is articulated.

The prop-shafts have the purpose of compensating the changes of the distance and angle between the transmission output shafts and input shafts of each axle, thus ensuring a smooth transfer of power from the transmission to the axles.

	W170/170PL	W190
Type	universal	universal
Length (between pins):		
Front	579 mm	675.5 mm
Intermediate	1020 mm	880 mm
Rear	104 mm	119.5 mm

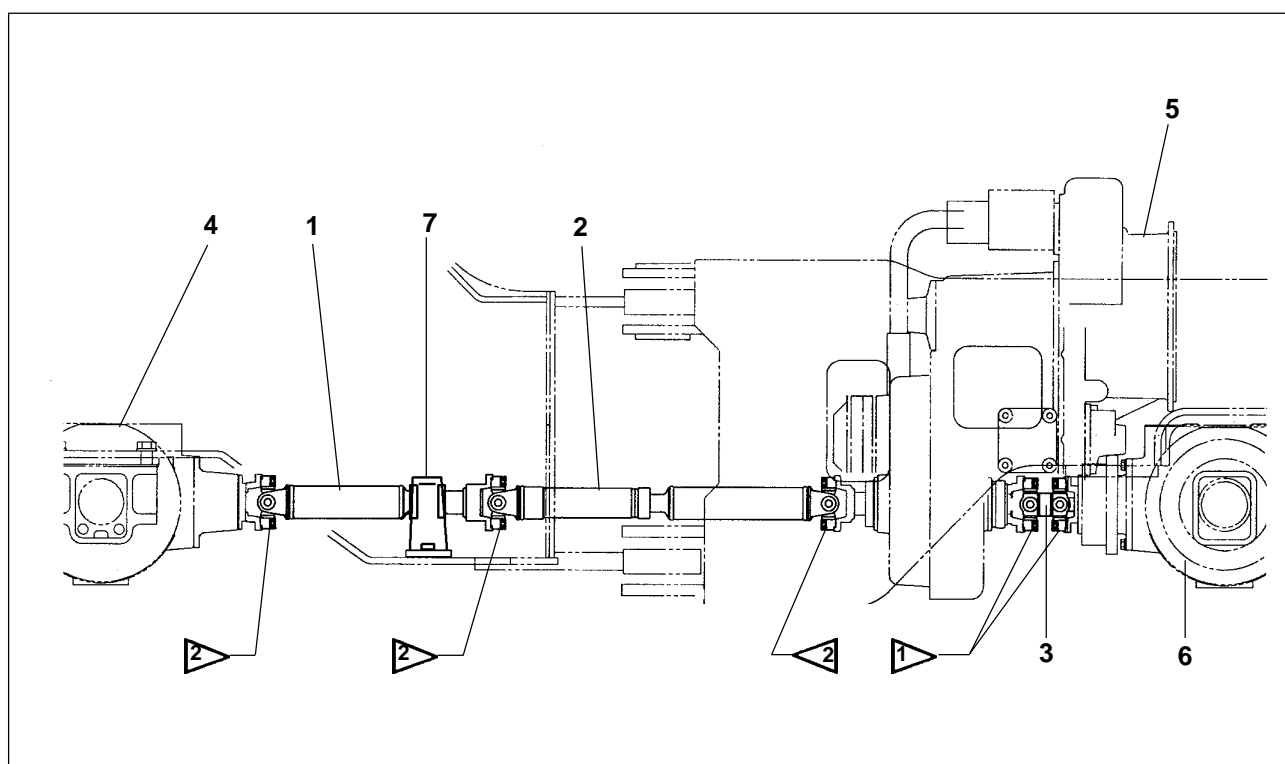

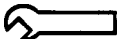

Fig. 2-456 Prop-shafts group

Nota -   7.5 ÷ 8.3 daNm (W170)
9 ÷ 16 daNm (W190)

  8.8 ÷ 10.2 daNm

 Threaded part: LOCTITE 262

 Threaded part: LOCTITE 262

- 1. FRONT PROP SHAFT
- 2. INTERMEDIATE PROP SHAFT
- 3. REAR PROP SHAFT
- 4. FRONT AXLE

- 5. TRANSMISSION
- 6. REAR AXLE
- 7. RIGID SUPPORT

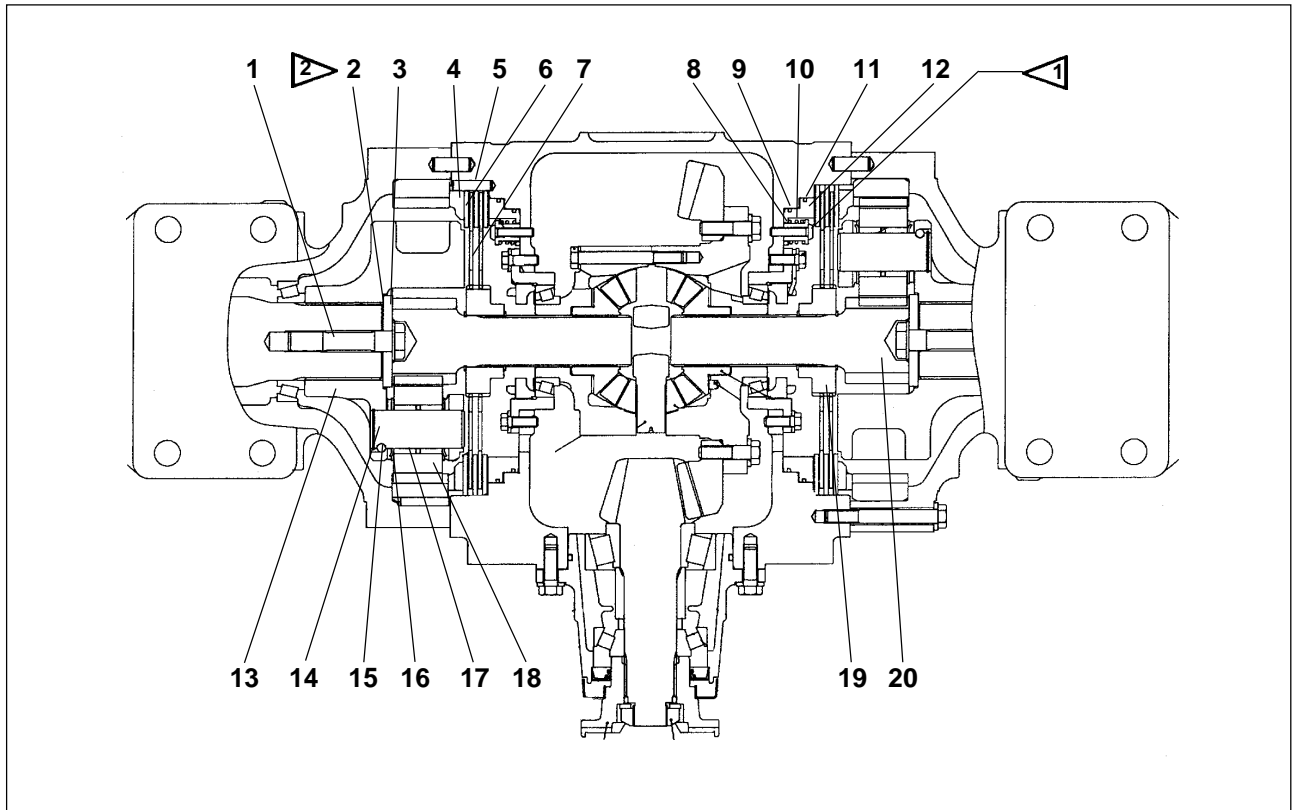





Fig. 2-466 Final drive

Note -  5 daNm (36 ft-lbs)

 Threaded part: LOCTITE 262

 Procedure for the setting of shims

- 1) Tighten screw (1) to a torque of 5 daNm (36 ft-lbs) and set inward the taper bearing, by rotating the axle shaft.
- 2) Loosen screw (1) without turning the shaft
- 3) Measure the gap between thrust ring (3) and axle shaft. Value measured = Y.
- 4) Select the adjusting shims to form a stack no thicker than 0.03 to 0.10 mm than value Y.
- 5) Install the shim pack, the retaining ring and the screw.

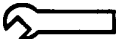
 111 daNm (803 ft-lbs)

 Threaded part: LOCTITE 262

The rolling torque of the bearing must be included between 2 and 4 daNm (4.4 ÷ 8.8 ft-lbs).

1.	SCREW	8.	ADAPTER	15.	BALL
2.	SPACER	9.	O-RING	16.	THRUST RING
3.	RETAINING PLATE	10.	SPRING	17.	NEEDLE BEARING
4.	THRUST RING	11.	O-RING	18.	PLANET GEAR
5.	LOCK PIN	12.	PISTON	19.	DISC HUB
6.	BRAKE DISC (OUTER TOOTHED)	13.	PLANET CARRIER	20.	SUN GEAR
7.	BRAKE DISC (INNER TOOTHED)	14.	PIN		

CLICK HERE TO **DOWNLOAD** THE COMPLETE MANUAL

- Thank you very much for reading the preview of the manual.
- You can download the complete manual from: www.heydownloads.com by clicking the link below



- Please note: If there is no response to CLICKING the link, please download this PDF first and then click on it.

CLICK HERE TO **DOWNLOAD** THE COMPLETE MANUAL

4. Remove the adjusting nut from the retainer. Then turn the retainer upside down and remove the bearing cup.
5. Remove the bearing retainer at the opposite side, using the same procedure as above.

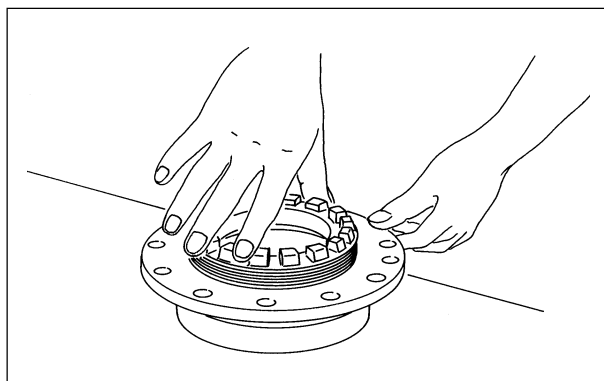

Fig. 2-502

6. Remove the ring gear and differential case assembly from the differential body.

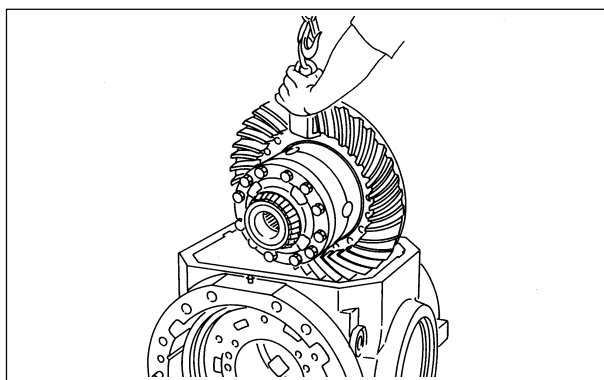

Fig. 2-503

8) Disassembling differential case

1. Loosen the bolts securing the ring gear and remove the ring gear.
Number of bolts: 16 for W170
20 for W190

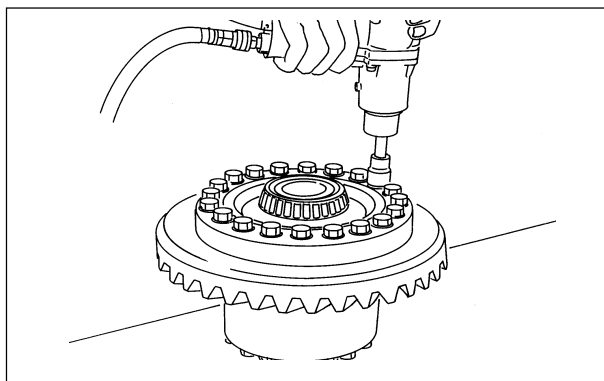

Fig. 2-504

2. Turn the differential case upside down and remove the 12 bolts securing the case from the plane half case side.

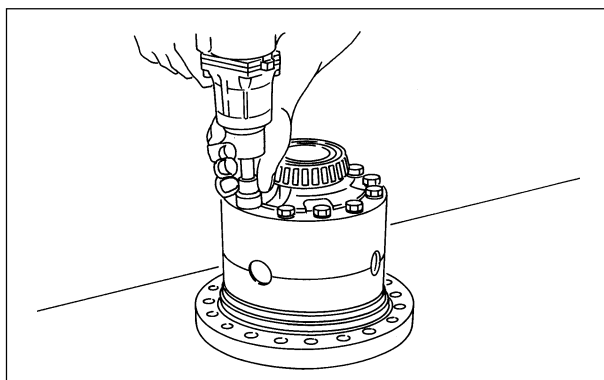

Fig. 2-505

3. Using a jig (1), tighten the right and left adjusting nuts to 10 to 12 kg-m (72 to 87 ft-lbs). Use a torque wrench to check the tightening torque.

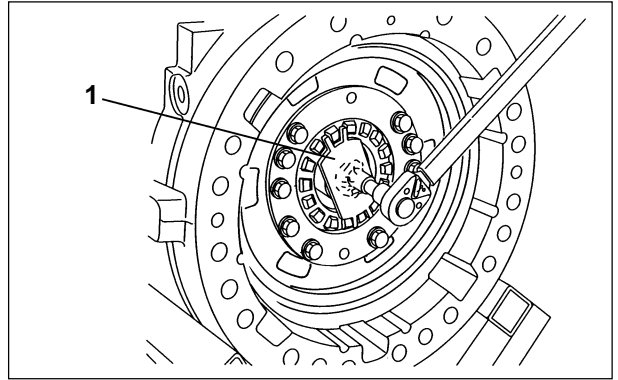

Fig. 2-539

4. Carry out steps "(5) Adjusting backlash of ring gear" and "(6) Adjusting the tooth surface contact pattern of ring gear". After that, install the lock plate and lock the adjusting nut.

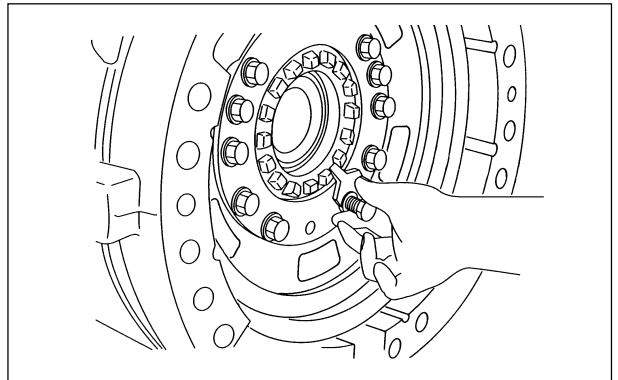

Fig. 2-540

5) Adjusting backlash of ring gear

1. Set a dial gauge on the tooth profile outer edge of the ring gear.
2. Fix the drive pinion, and turn the ring gear back and forth to measure the backlash.

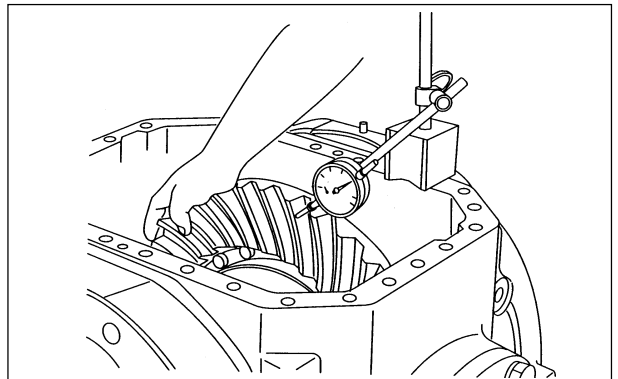

Fig. 2-541

3. If the backlash is too large, loosen the adjusting nut on the plane half case, tighten the adjusting nut on the flange half case and bring the ring gear closer to the drive pinion. If the backlash is too small, adjust it in the opposite procedure as above.

Ring gear backlash

Standard value: 0.25 - 0.36 mm
(0.0098 - 0.0142 in)

9. Apply LOCTITE 262 to the threaded area of the retainer plate mounting bolt and tighten the bolt to the specified torque to secure the planet carrier. Fig. 578 shows the planet carrier being installed with the nut runner.
10. Reassemble the other axle tube, using the same procedure as above. Refer to the (8) to (9).

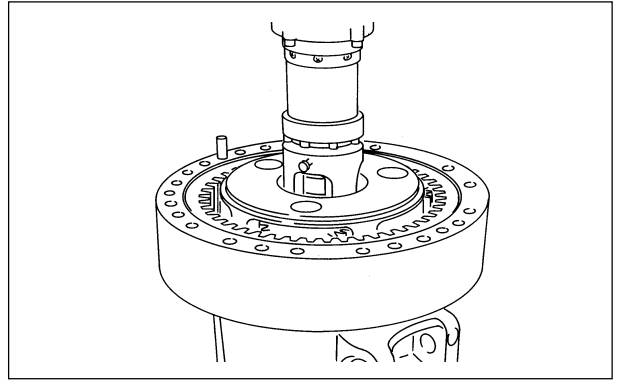

Fig. 2-578

11) Installing axle tube

1. Apply LOCTITE FMD-127 to the differential body surface which will mate with the axle tube. Make sure that the beads of LOCTITE are applied, without a break, on the differential body surface inside row of the bolt holes. The bead width is 2 to 3 mm (0.08 to 0.12 in) each.

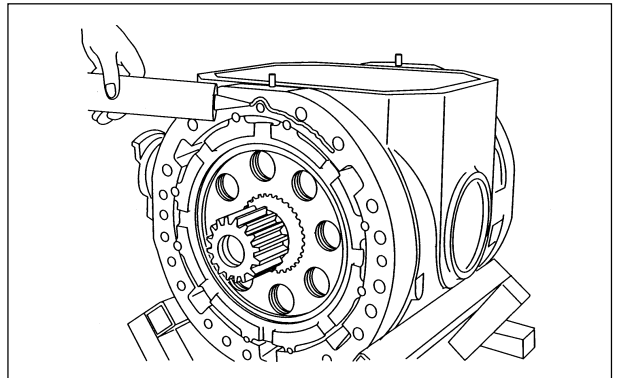

Fig. 2-579

2. Lift axle tube horizontally and install it onto the differential body, aligning with the sun gear and mounting bolt holes. Apply LOCTITE 262 to the threaded area of mounting bolts and tighten them. Number of bolts: 16 for W170
20 for W190
3. Install the axle tube at the opposite side, using the same procedure as above.

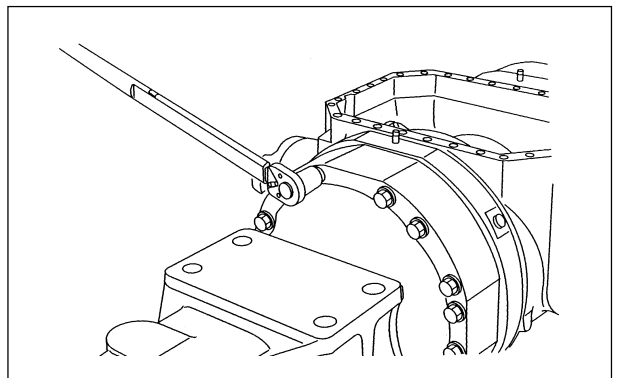

Fig. 2-580

4. Apply LOCTITE FMD-127 to the cover mounting area of the differential body. Make sure that the beads of LOCTITE are applied, without a break, on the body surface inside row of the bolt holes.

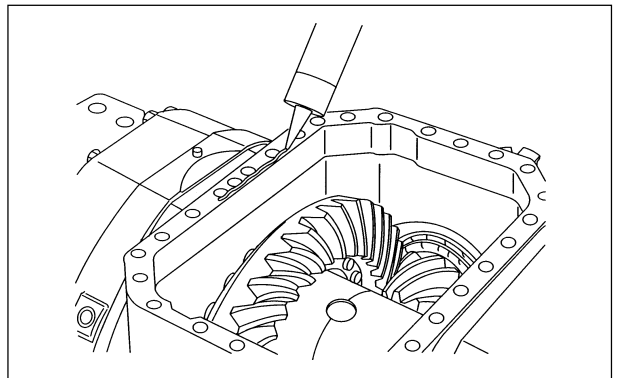

Fig. 2-581

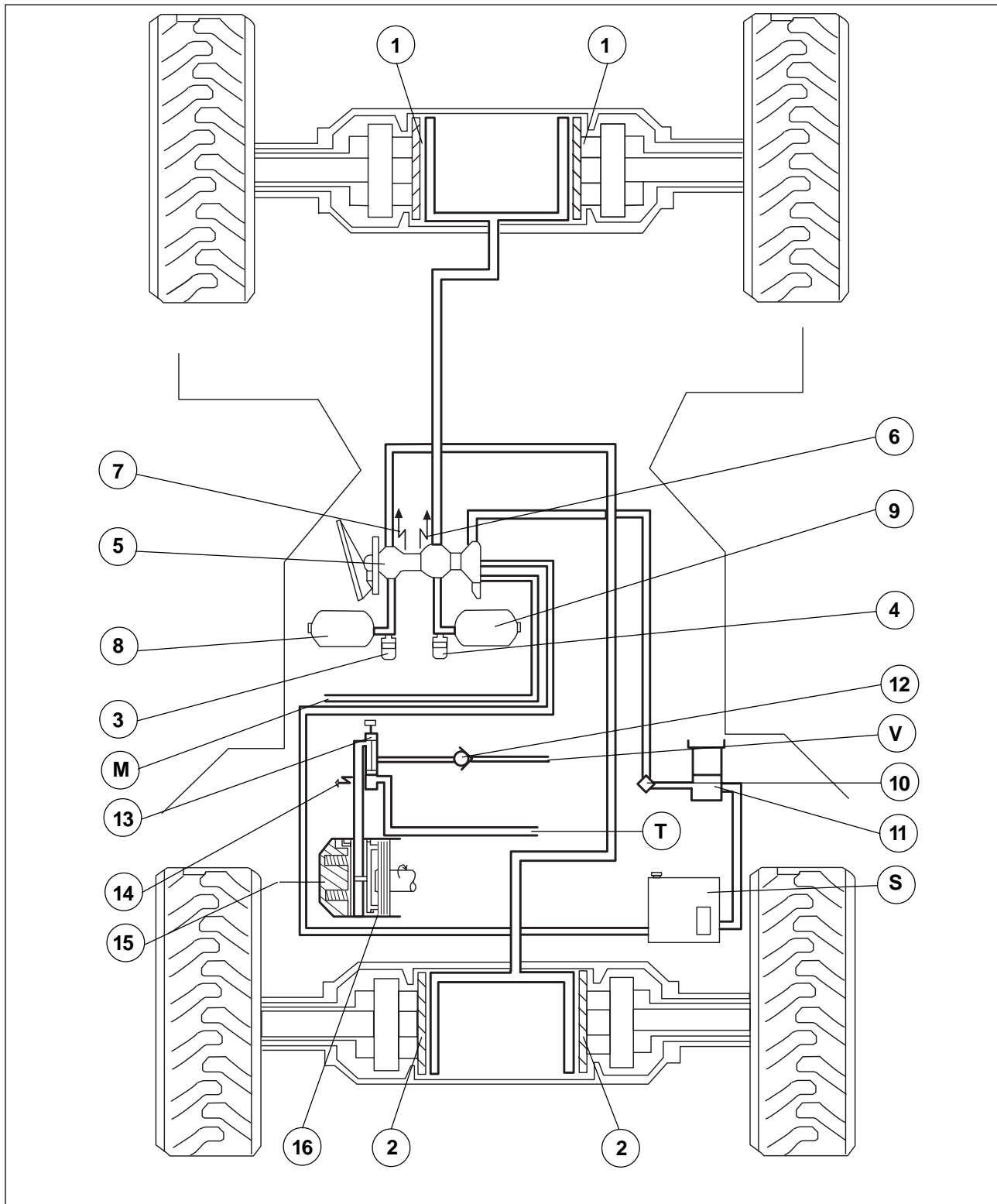

Fig. 3-1 Brakes system

S. Reservoir - **M.** To pressure regulating valve - **V.** To pressure regulating valve - **T.** Discharging (hydraulic reservoir) - **1.** Front brakes- **2.** Rear brakes - **3.** and **4.** Quick release pressure pick-up points - **5.** Brake pedal valve - **6.** Stop light pressure switch - **7.** Transmission cut-off pressure switch - **8.** and **9.** Brakes system accumulators - **10.** Oil delivery filter - **11.** Brakes oil pump - **12.** Check valve - **13.** Parking brake control three way diverter - **14.** Parking brake pressure switch - **15.** Hydraulic cylinder (included in the parking brake) - **16.** Parking brake.

3.6 PARKING BRAKE CONTROL VALVE

The parking brake valve controls the delivery of pressurised oil to the disc brake.

The movement of the parking brake valve is controlled by the appropriate knob actuating the discs brake.

The parking brake is equipped with detent devices to hold the spool, in each position.

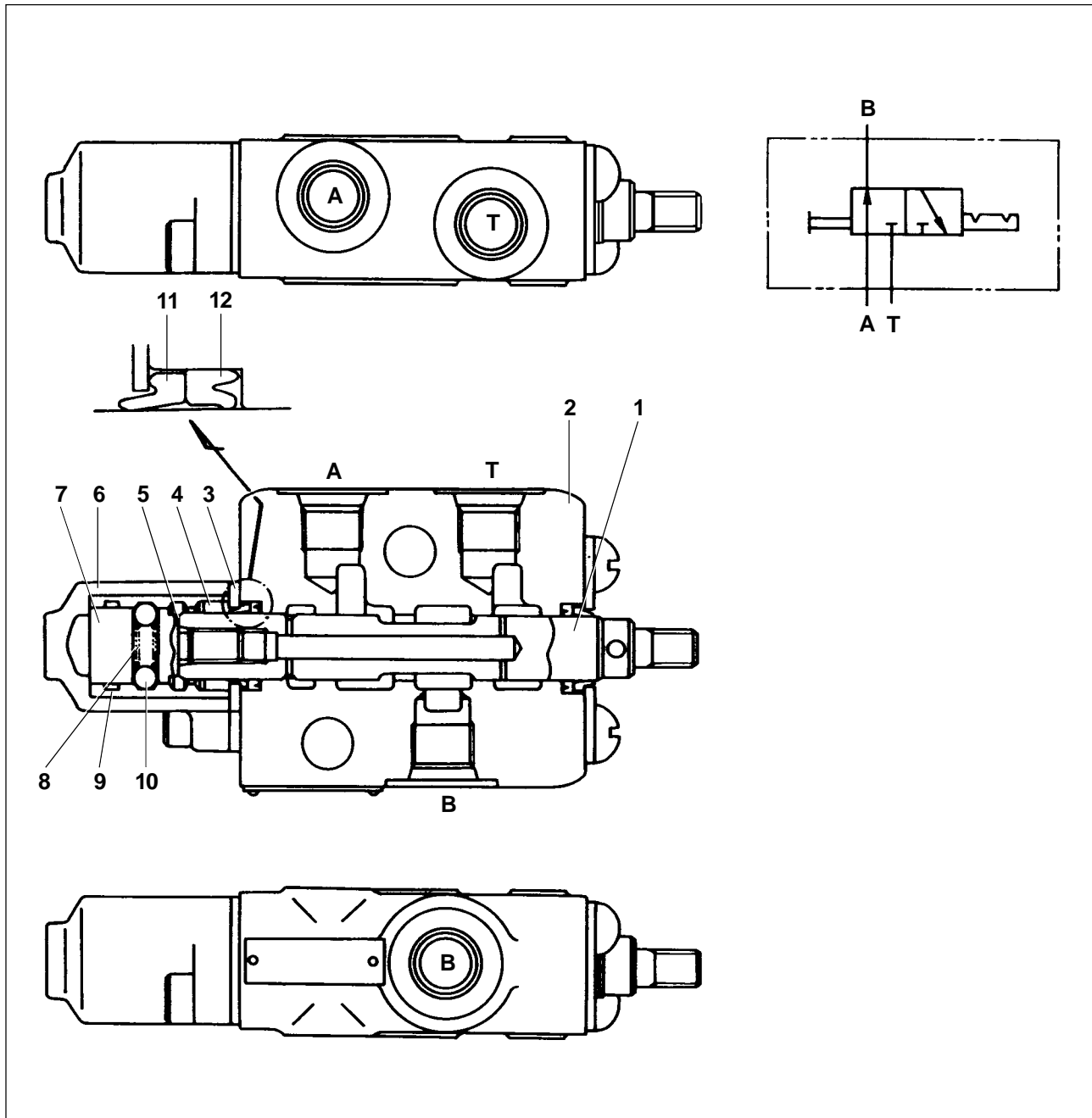

Fig. 3-9 Parking brake valve

1. Rod - 2. Valve body - 3. Gland ring - 4. Ring - 5. O-Ring seal - 6. Cover - 7. Spool - 8. Detent spring - 9. Sleeve - 10. Detent ball - 11. Dust ring - 12. Oil seal.

3.10.4 ACCUMULATOR PRE-CHARGE TEST

Accumulators fitted to the braking system are membrane type, pre-charged using nitrogen.

Normal minimum membrane porosity and continued use reduce pre-charge pressure in time and limit accumulator efficiency.

It is advised to check the nitrogen pre-charge every six months and restore it, if necessary.

Pre-charge pressure should never drop below approximately 90% of the rated value.

Check is to be carried out with the accumulators drained of hydraulic oil. This condition is obtained as follows:

- as regards accumulators (7 and 8, Fig. 3-2) by pressing the brake pedal slowly several times;
- as regards the parking brake release accumulator (13, Fig. 3-2) by operating repeatedly the diverter valve (14) with the engine stopped.

Check the pre-charge as follows:

- remove protection cover (1, Fig. 3-20);
- loosen the screw (2) by half turn using a hexagonal Allen wrench;
- screw in tool D on the accumulator connection;
- ensure that tap (D2) is closed;
- turn the handwheel (D1) to loosen the screw (2);
- when the pointer of the pressure gauge (M) starts moving, turn out the handwheel (D1) by one more turn.

Now the pressure gauge shows the accumulator pre-charge pressure, which should be 45 bar.

If pressure is within the specified range of values, proceed as follows:

- close handwheel (D1);
- open tap (D2) to discharge nitrogen pressure from within the tool (D);

- disconnect tool (D) from the accumulator;
- tighten the screw (2) to a torque of 1.1 daNm;
- test accumulator sealing using soapy water;
- screw on protective cover (1).

Recharge the accumulator if the pressure is lower than rated value.

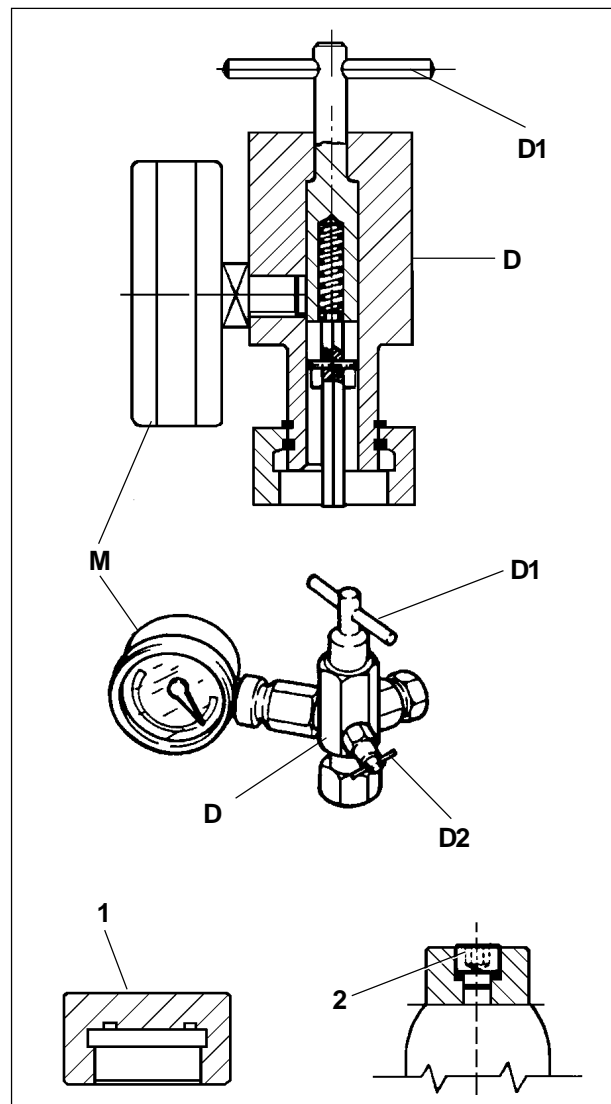

Fig. 3-20 Accumulator pre-charge test

D. Accumulator pre-charge test tool - D1. Plug control handwheel (2) - D2. Discharge tap - M. Pressure gauge - 1. Protective cover - 2. Threaded plug.

BIANCA

4.5 STEERING VALVE CONTROL LINKAGE

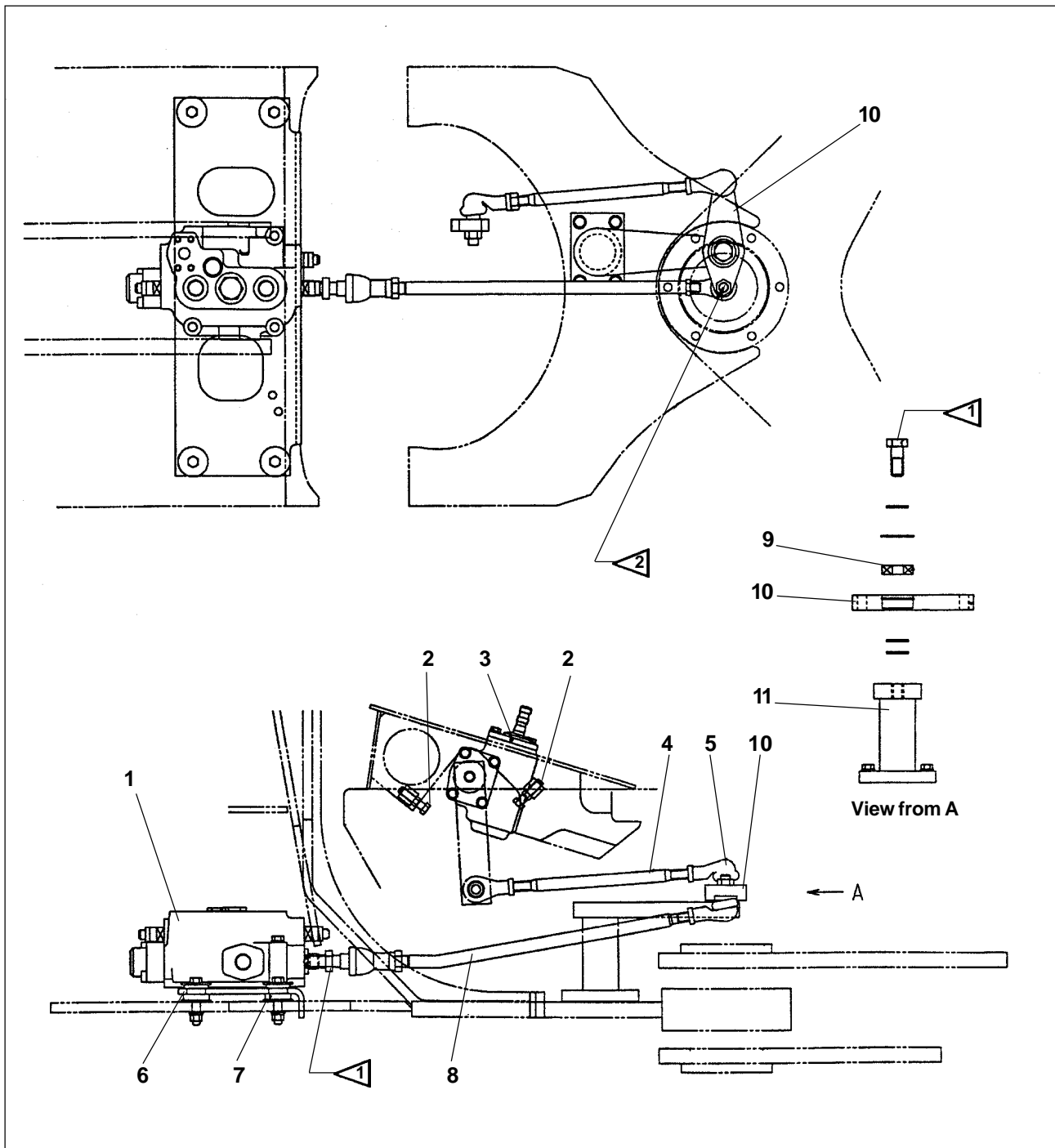





Fig. 4-13 Control linkage

Notes:   Threaded area: LOCTITE 262  Align with central articulation pin centre line

- | | | |
|---------------------|------------------|------------|
| 1. STEERING VALVE | 5. BALL JOINT | 9. BEARING |
| 2. STROKE END SCREW | 6. SUPPORT PLATE | 10. LEVER |
| 3. STEERING BOX | 7. RUBBER PAD | 11. PIN |
| 4. ROD | 8. ROD | |

1. PUMP

Designation: SAUER-SUNDSTRAND TAM 22-90/38
Type: gear
Drive: gear
Delivery: 38 cu cm/turn
Max. pressure: 210 bar
Max. speed: 3000 rpm

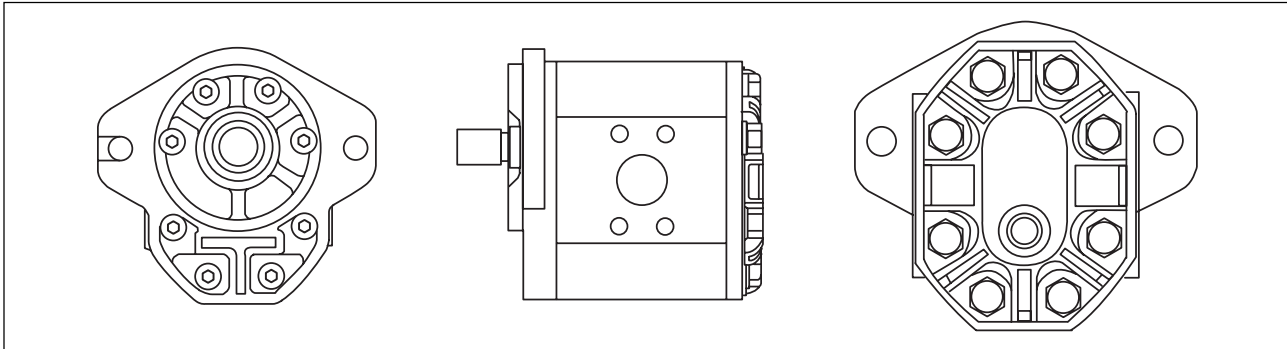

Fig. 4-23 Emergency steering pump

2. DIVERTER VALVE

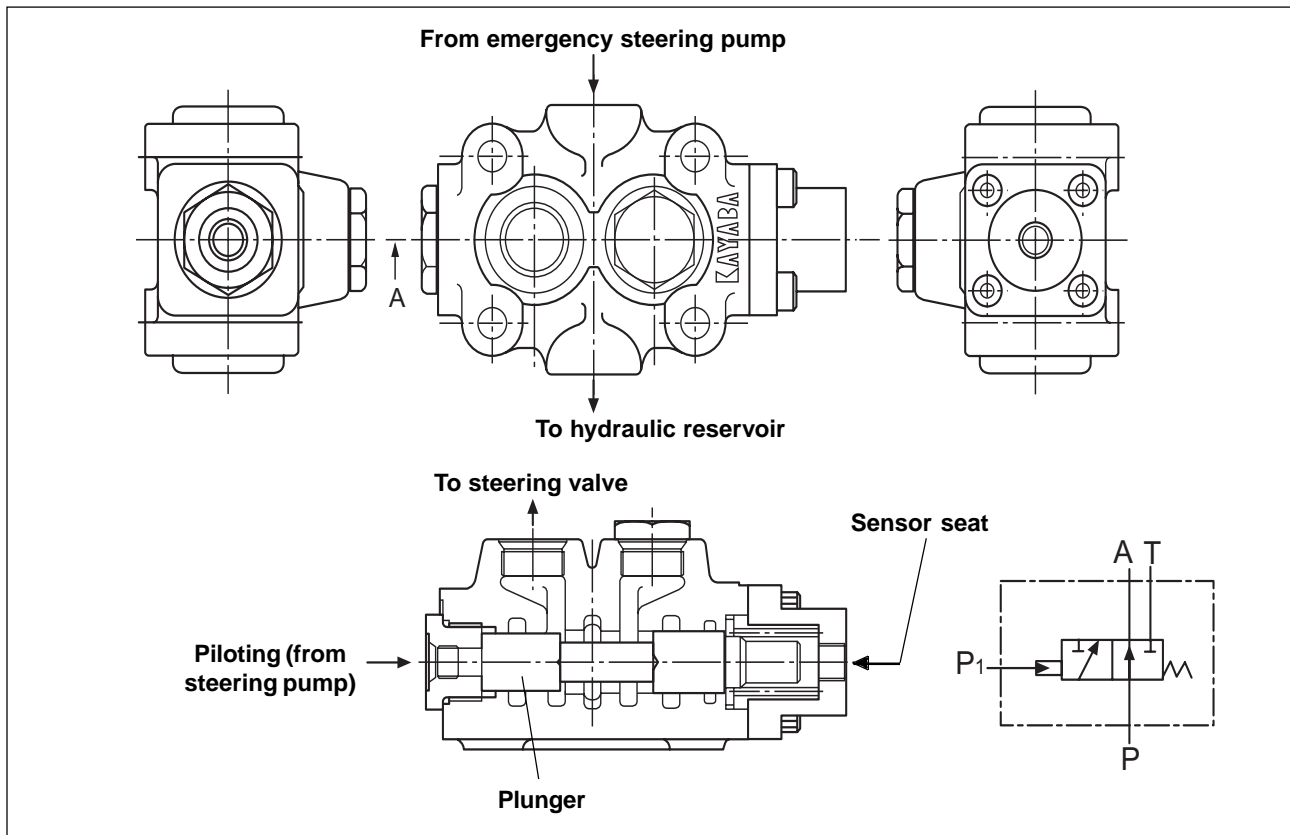

Fig. 4-24

5.2 FRAME

The frame is of a welded steel plate type and is divided into two parts: front and rear frames. The cab is mounted on the rear frame.



WARNING

Do not attempt any modification on the ROPS (Roll over protection structure), if installed, without prior authorisation by the Manufacturer. In the event the ROPS is damaged or deformed, as a consequence of a roll over or a collision, it is recommended that it is replaced by a new one, since a damaged or deformed ROPS has a low structural resistance.

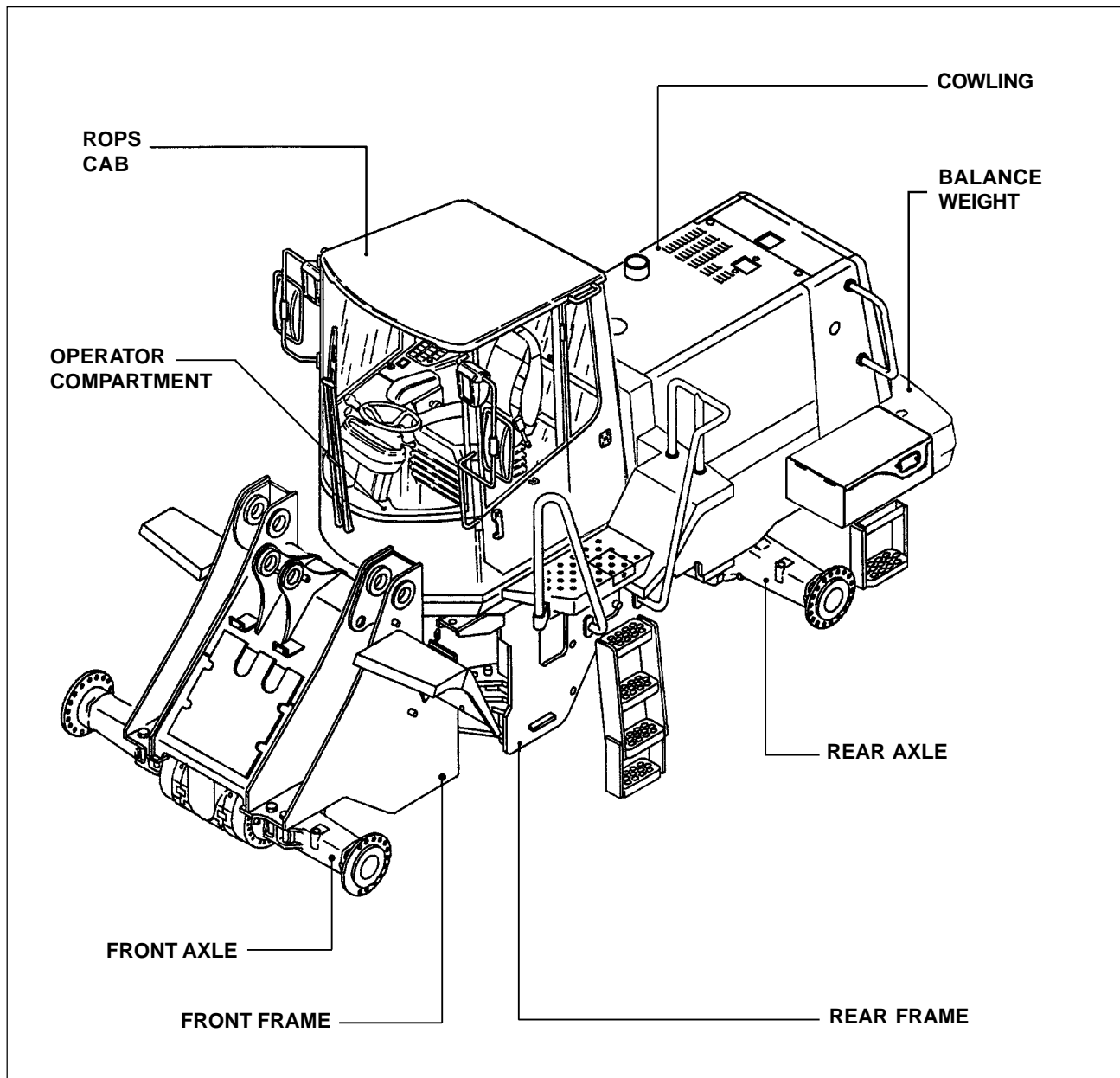
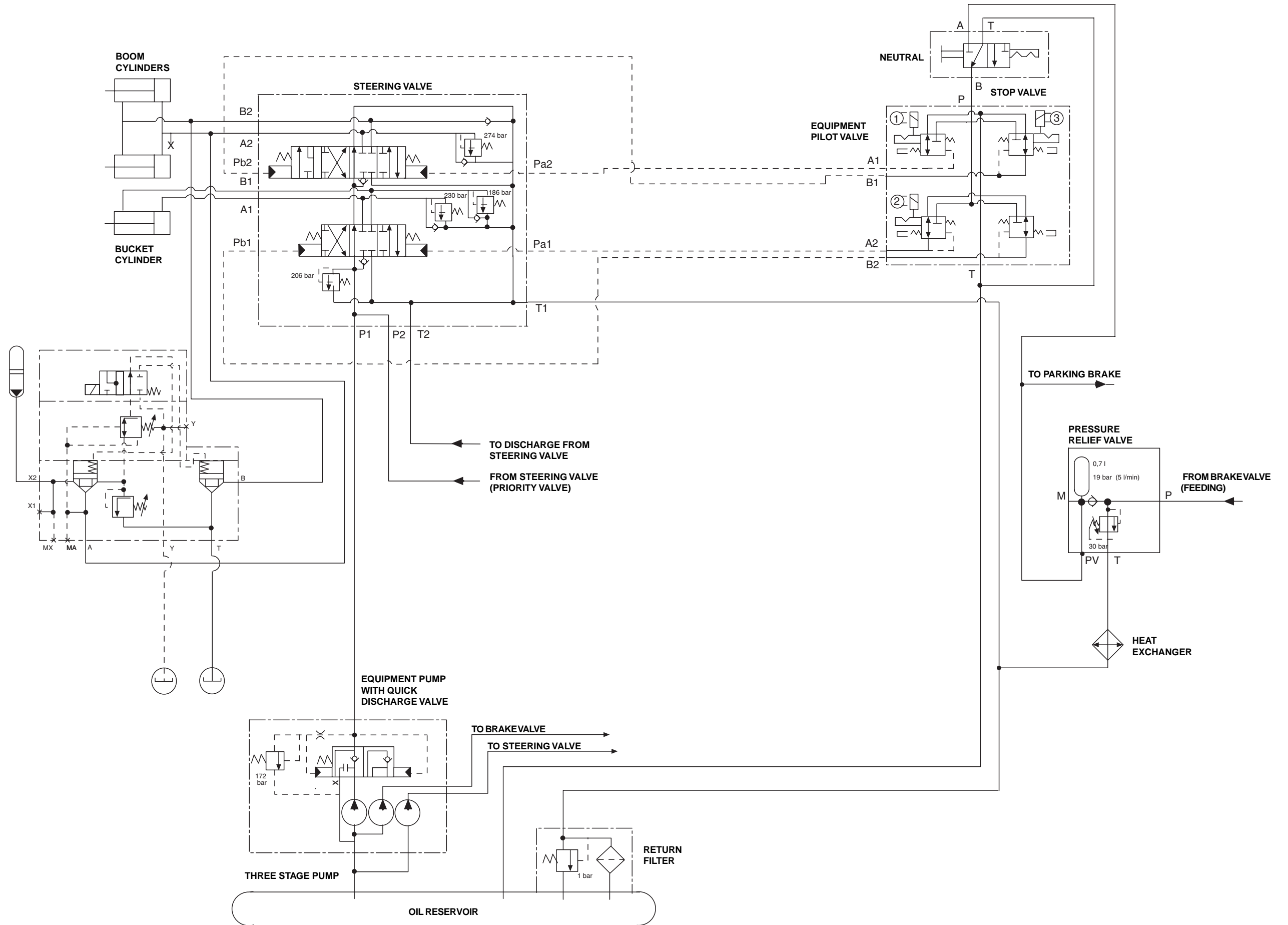

Fig. 5-7 Frame

Fig. 6-2 W170 equipment hydraulic system



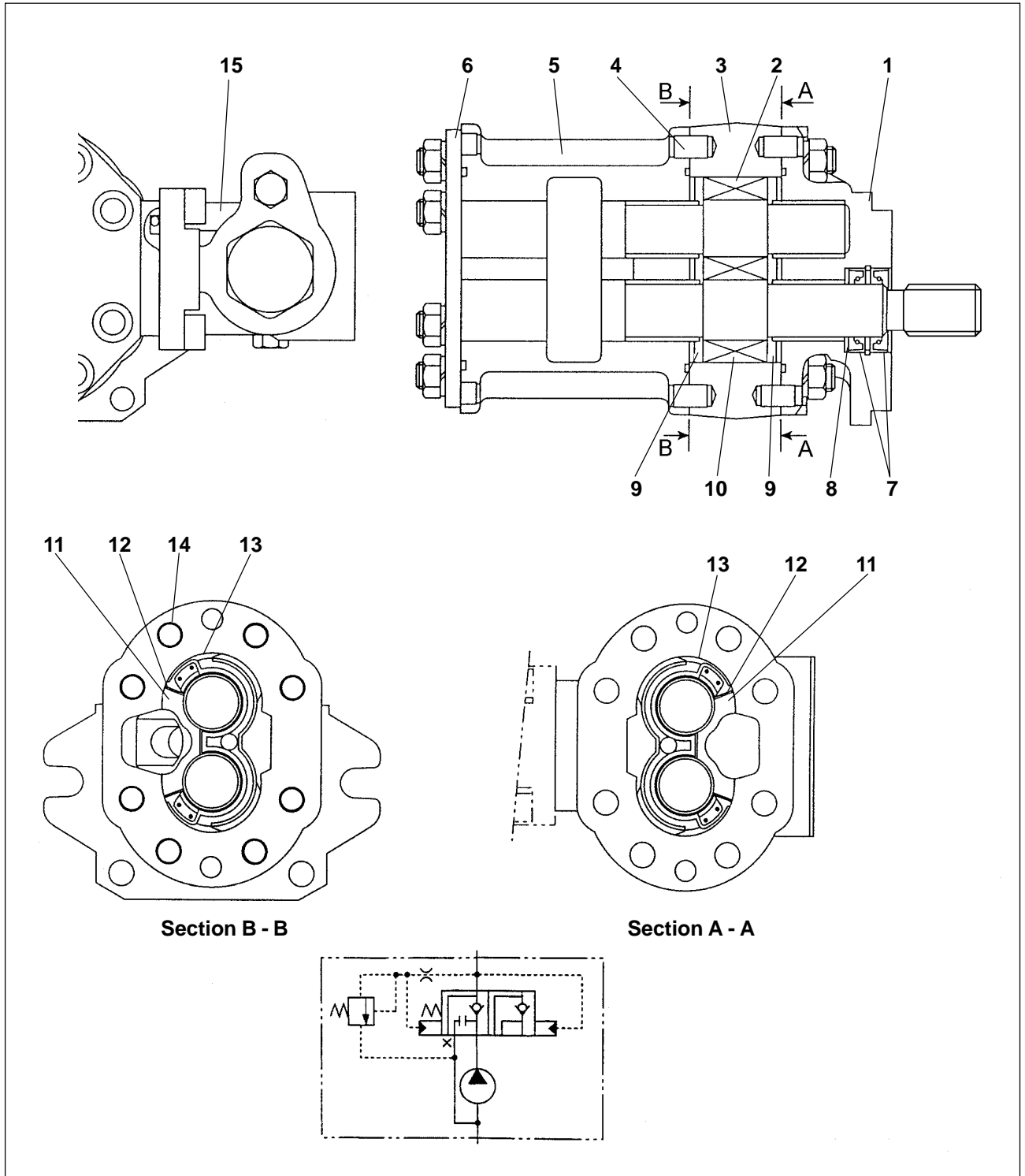

Fig. 6-8 Section of equipment pump (W190)

- | | | |
|-----------------------|------------------|-------------------|
| 1. MOUNTING FLANGE | 6. PLATE | 11. PLATE |
| 2. DRIVEN GEAR | 7. WASHER | 12. BACK-UP RING |
| 3. GEAR BODY | 8. WASHER | 13. SEAL |
| 4. DOWEL | 9. PLATE | 14. DOWEL |
| 5. INTERMEDIATE PLATE | 10. DRIVING GEAR | 15. BY-PASS VALVE |

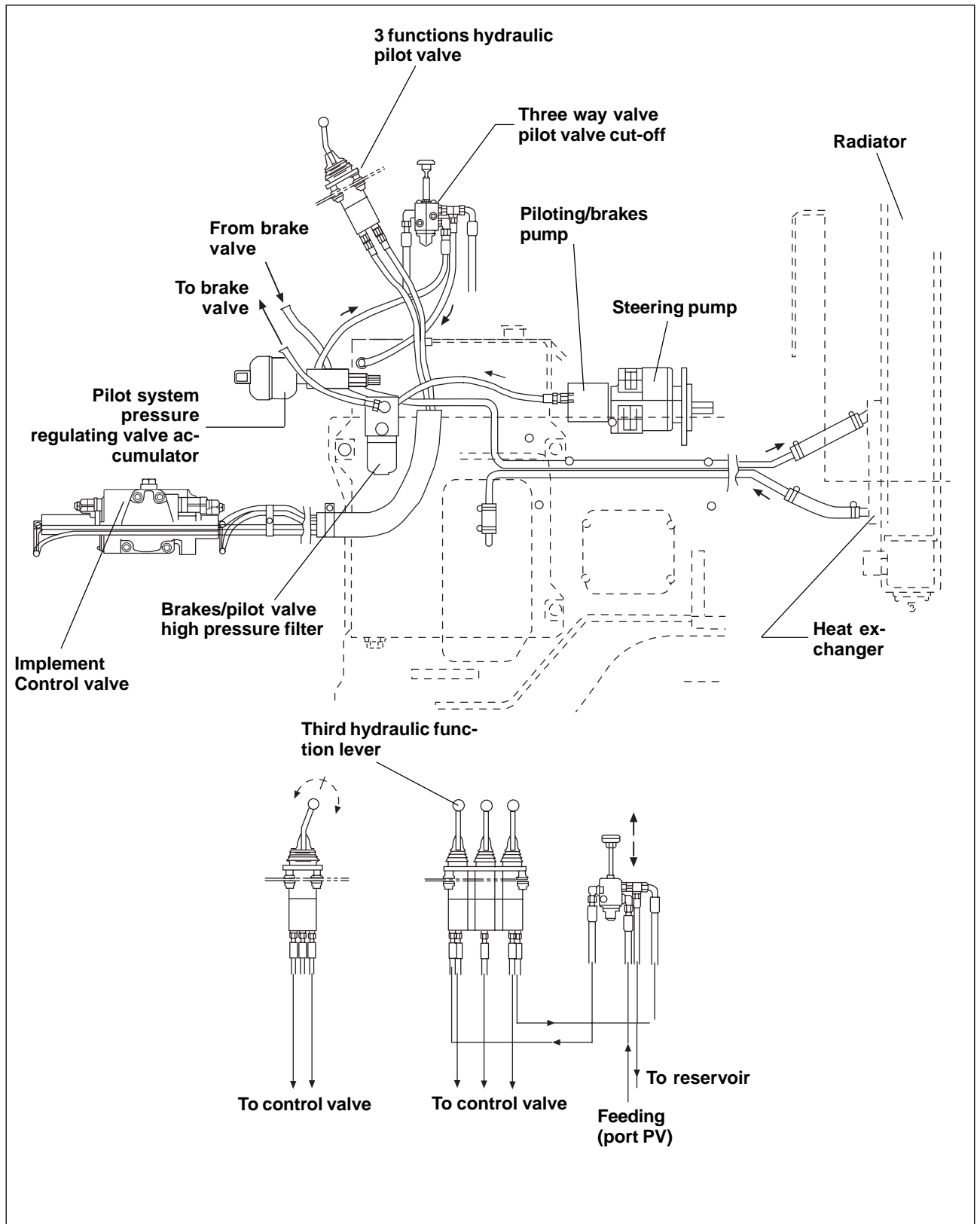

Fig. 6-25 Equipment control valve assembly

Note - The layout represented in the figure refers to mod. W190.
The differences with mod. W170/170PL involve only the steering/brakes/pilot system pump.

6.5 SAFETY HYDRAULIC SYSTEM

With special arrangements, such as quick release coupling or "Parallel" version, implying the use of forks, the machine results being, at all effects, a fork lift truck, requiring a safety circuitry capable of not allowing that the load lifted could drop accidentally; example: rupture of a pipe on the booms. The circuitry includes a valve anti drop valve on the bucket tilt cylinder and a dual valve on the boom cylinders. The circuitry includes an anti drop valve on the bucket rotation cylinder and two block valves for the boom cylinders. In case the L.T.S. anti locking function has to be used, the block valves can be cut-off by an electric control located in the cab. Please refer to Fig. 6-39 for the wiring diagram.

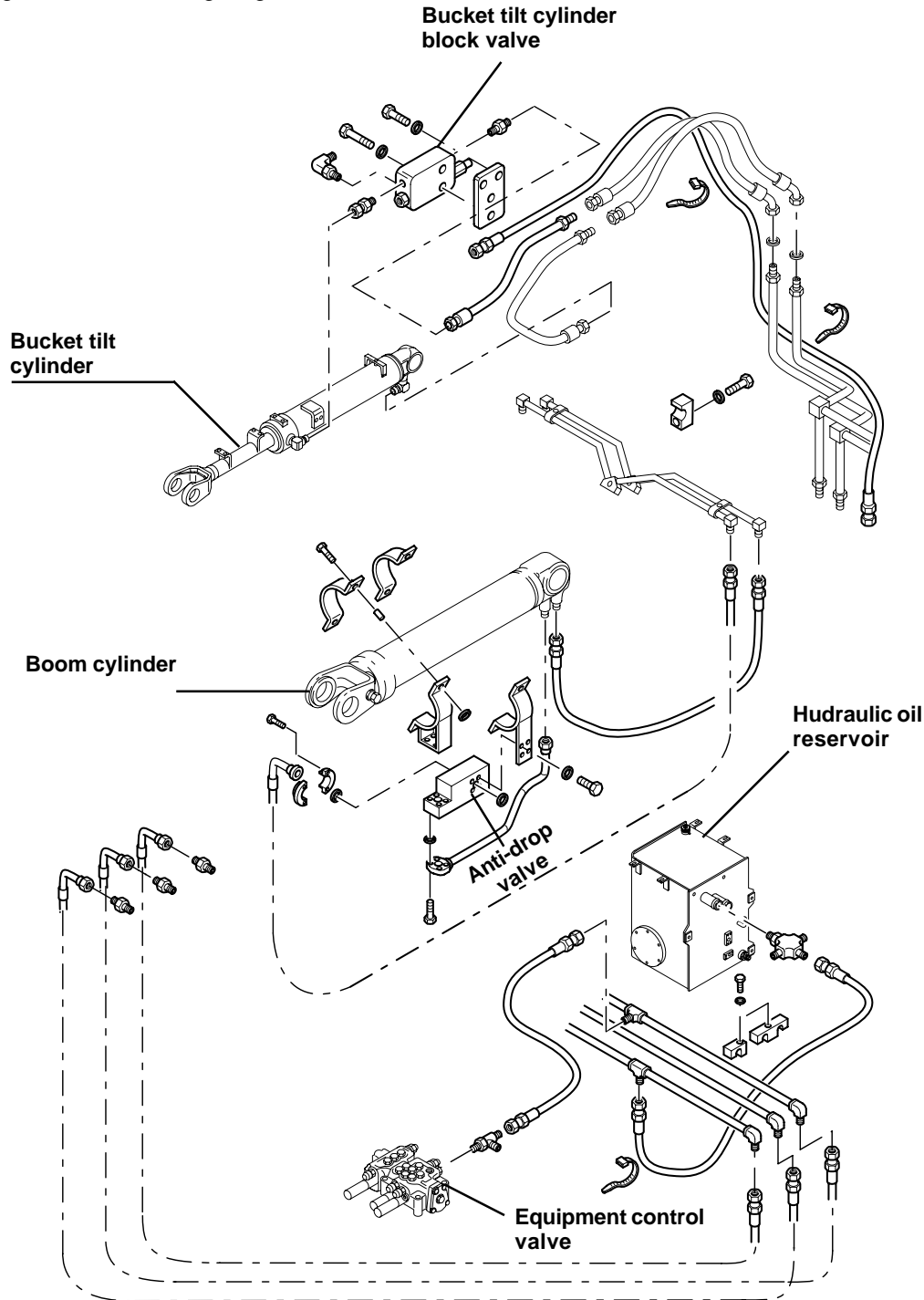

Fig. 6-36 Configuration of safety hydraulic circuit

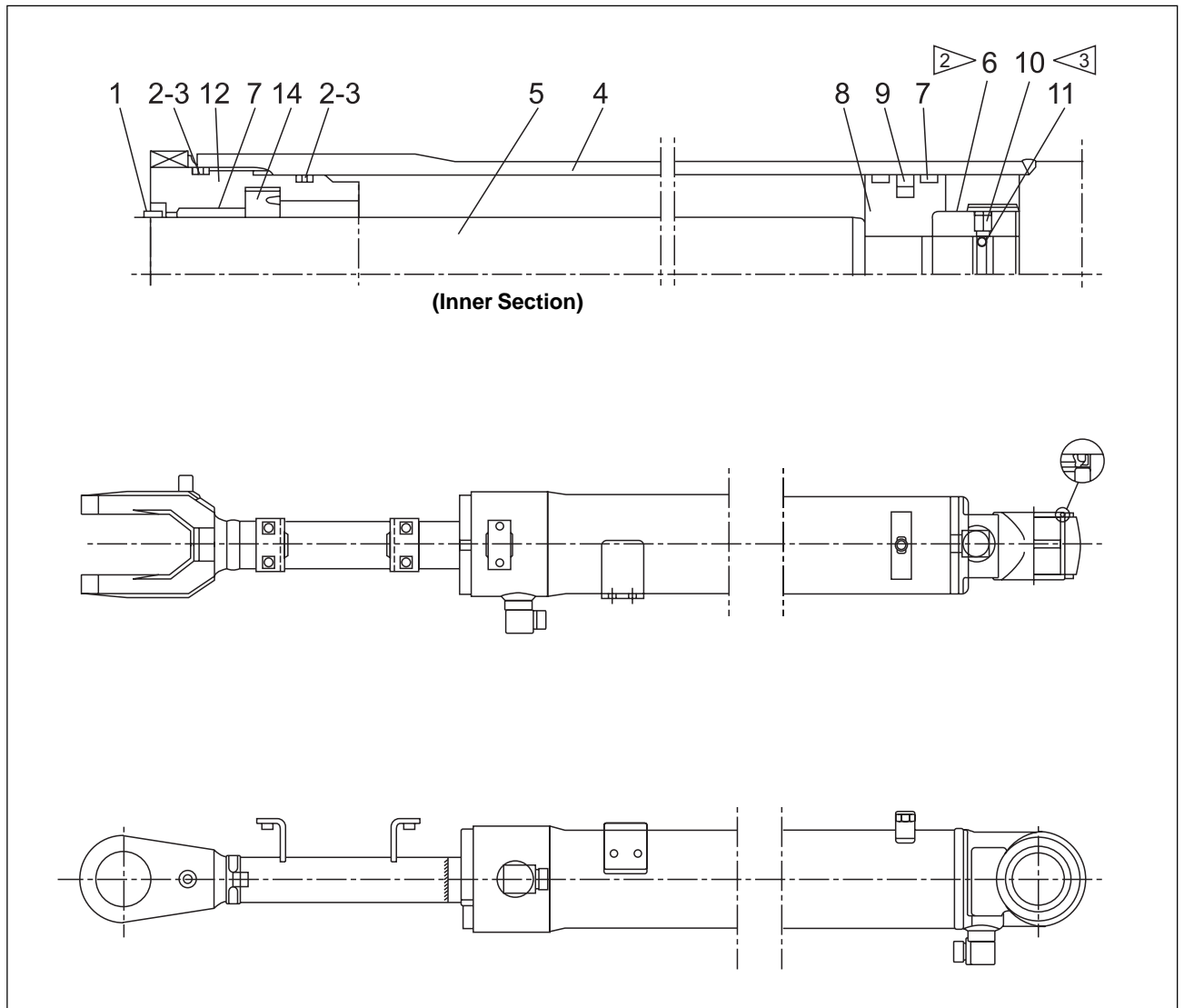

Fig. 6-45 Bucket cylinder W170PL

daNm (ft-lbs)		W170PL
1		106 (782)
2		230 (1697)
3		3.15 (23,2)

Note -

- 1. MUD SCRAPER RING
- 2. O-RING HOLDER
- 3. O-RING
- 4. CYLINDER SLEEVE
- 5. ROD
- 6. PISTON LOCKING NUT
- 7. SLIDING RING
- 8. PISTON
- 9. SEAL/O-RING
- 10. HOLDING SCREW
- 11. STEEL BALL
- 12. FRONT HEAD
- 13. SHIM
- 14. SEAL

7.2 LOGIC BOARD AND CAB CONNECTIONS

The logic board is located inside the rear panel behind the operator seat. To reach it, loosen the four retaining knobs. All the components of the machine are connected to the board by the “CN” connections.

Here are also located the fuses, the solenoid switches (“R” relays), the timers “Z” and two switches “SW1” and “SW2” to divert the gearshift control from automatic to manual and viceversa

7.2.1 CONNECTIONS - RELAYS - TIMERS - BUZZER

CONNECTIONS CN			
CN	LINE CONNECTED	COLOUR	TERMINALS
A	cab	violet	17
B	switches	black	21
C	engine	white	17
D	switches	brown	17
E	transmission box	white	17
F	dashboard and lights	red	17
G	dashboard	yellow	17
H	engine	black	19
J	switches	green	11
K	engine	violet	21
L	optional instruments	light blue	13
M	engine	white	21
N	transmission	white	11
O	gearshift	white	7
P	engine	yellow	13
Q	voltage reduction	white	5
R	thermo starter	white	13
S	service relay, buzzer	black	5
N-N	bridges manual gearshift	white	11

RELAY R	
R=relay	FUNCTION
2	horn
3	light switching
4	starter and anti repetition
5	neutral starter safety
6	clock
7	back-up lights and alarm
8	air cond. condenser fan
9	transmission cut-off
10	L.T.S.
11	kick-down
12	kick-down

TIMERS AND OTHERS	
Z1	steering low pressure switch
Z2	check timer
Z3	emergency flasher
C1	capacitor
C2	capacitor
SW1	micro switch
SW2	micro switch
JP1	bridge
JP2	bridge
R1	resistor

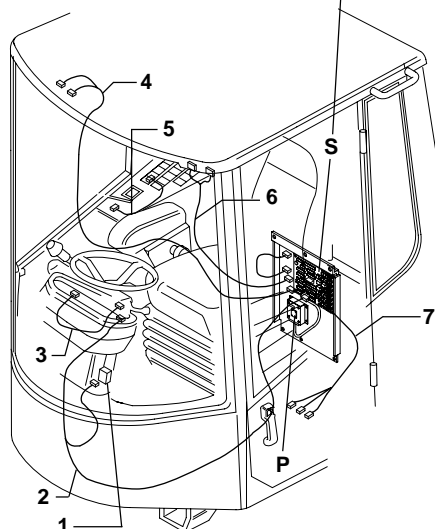
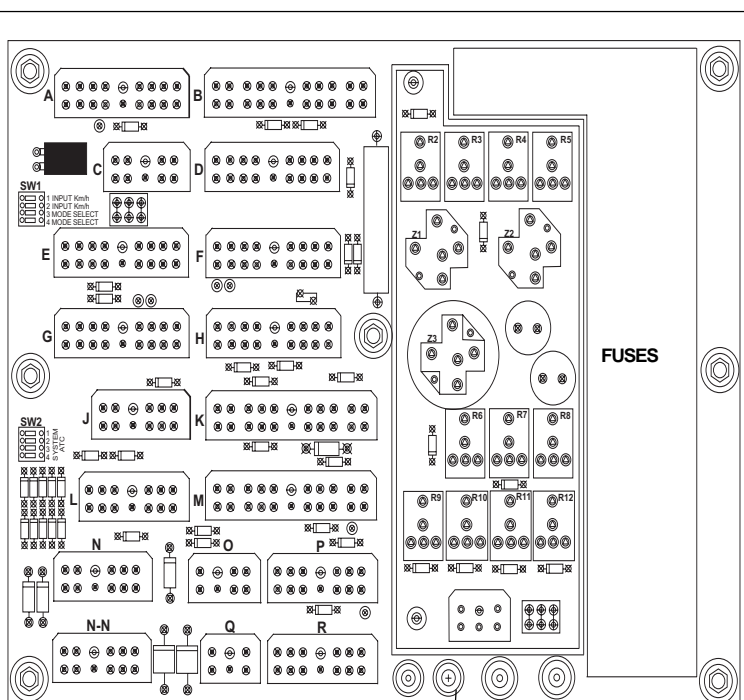

P. Engine warm-up control unit - S. Logic board - 1. Wiper timer - 2. Steering column wire - 3. Front dashboard wire - 4. Cab roof wire - 5. Heater wire - 6. Side dashboard wire - 7. Cab wire

7.8 COLD START AND "LINK" FUSES

MACHINE SERVICES "LINK" FUSE (50A)

WIRES

- 777: to + of batteries
- 772: to derivation box

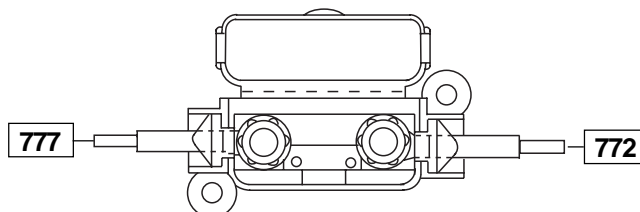

ALTERNATOR "LINK" FUSE (80A)

WIRES

- 777: to + of batteries
- 773: to alternator

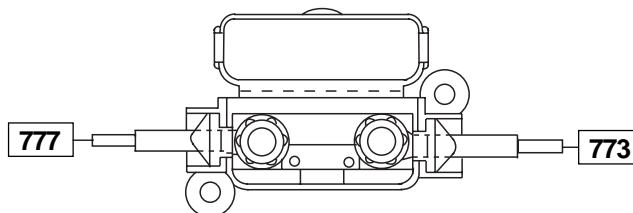

COLD START FUSE (150A)

WIRES

- 777: to + of batteries
- 780: to thermostarter relay

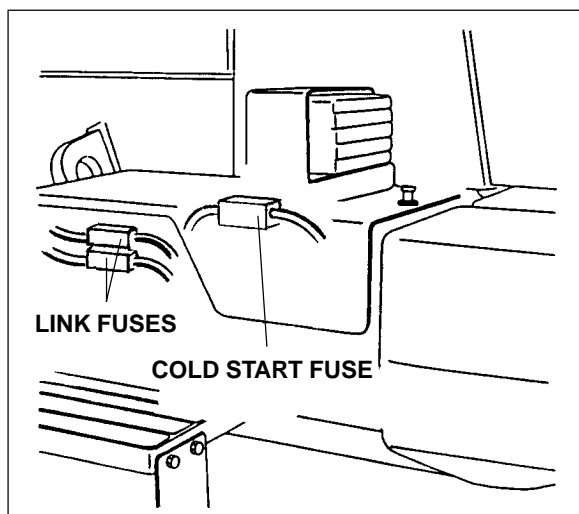
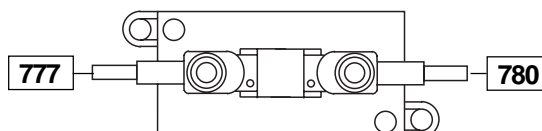

Fuses location: inside left battery compartment.

PROXIMITY SENSOR (180, TAB. 2)
(Accelerator pedal)

WIRES

- 538:** to ATC electronic unit
981: to F10A fuse on logic board
000: to ground

TECHNICAL SPECIFICATIONS

Thread: M18x1

Tightening torque: 2 daNm

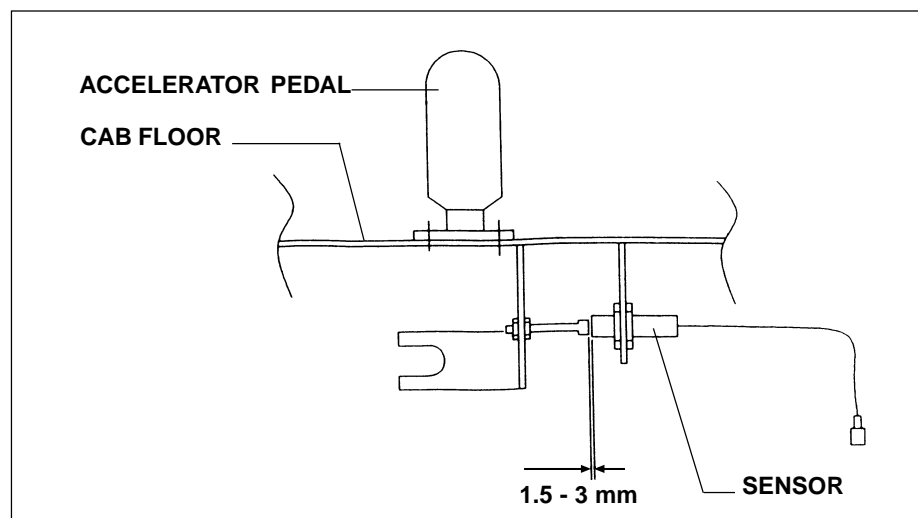
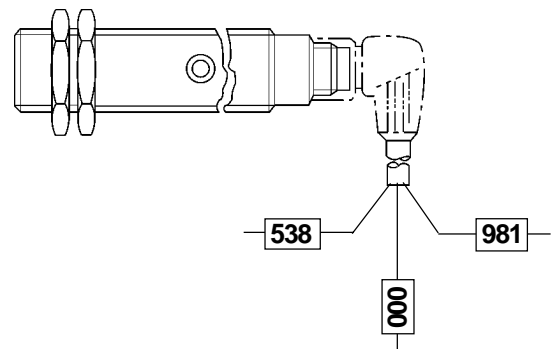

LOCATION - Under accelerator pedal

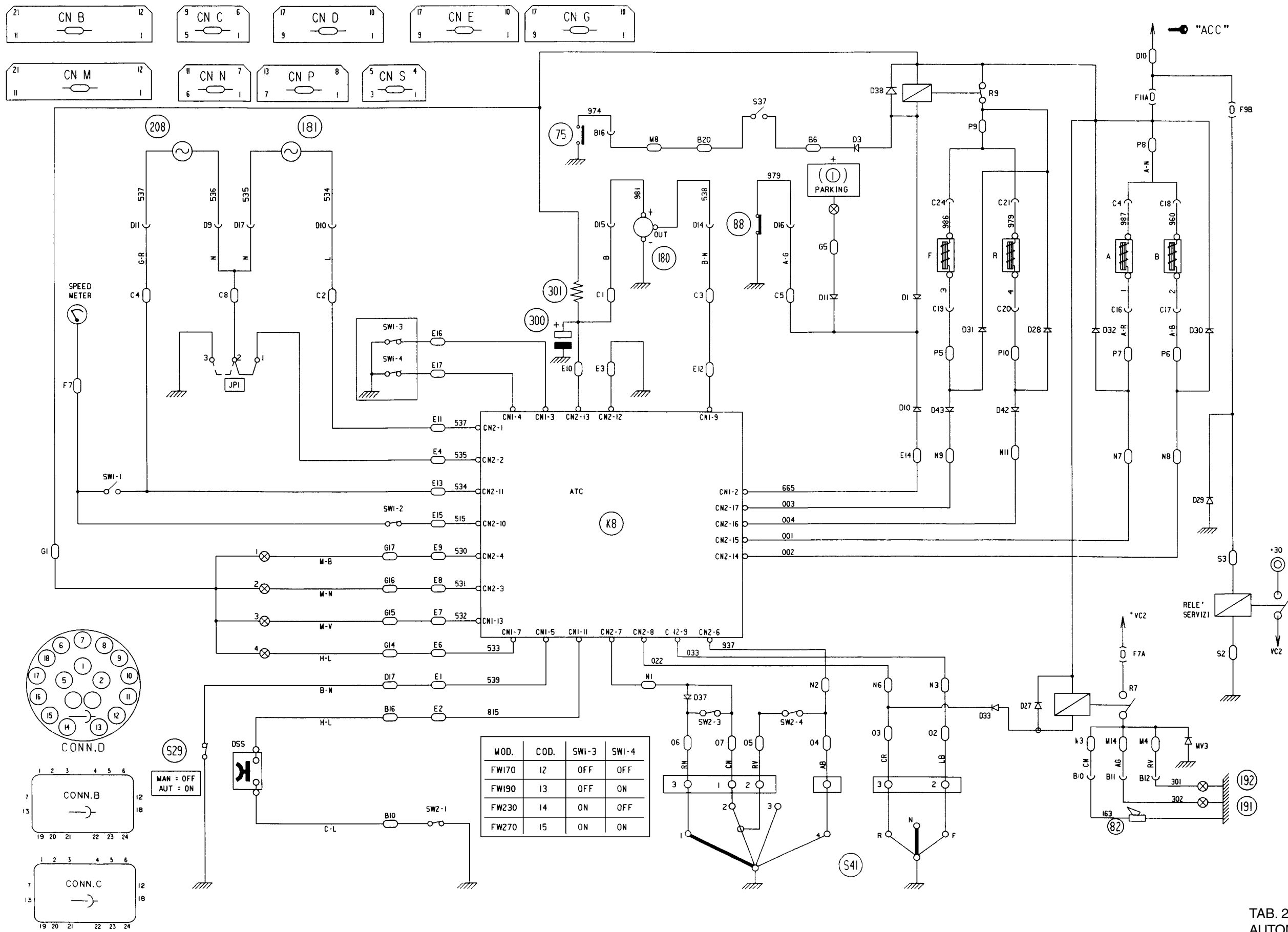

MOD.	COD.	SWI-3	SWI-4
FW170	12	OFF	OFF
FW190	13	OFF	ON
FW230	14	ON	OFF
FW270	15	ON	ON

TAB. 2
AUTOMATIC TRANSMISSION

Carefully read personal and machine SAFETY PRECAUTIONS (at the beginning of this manual)

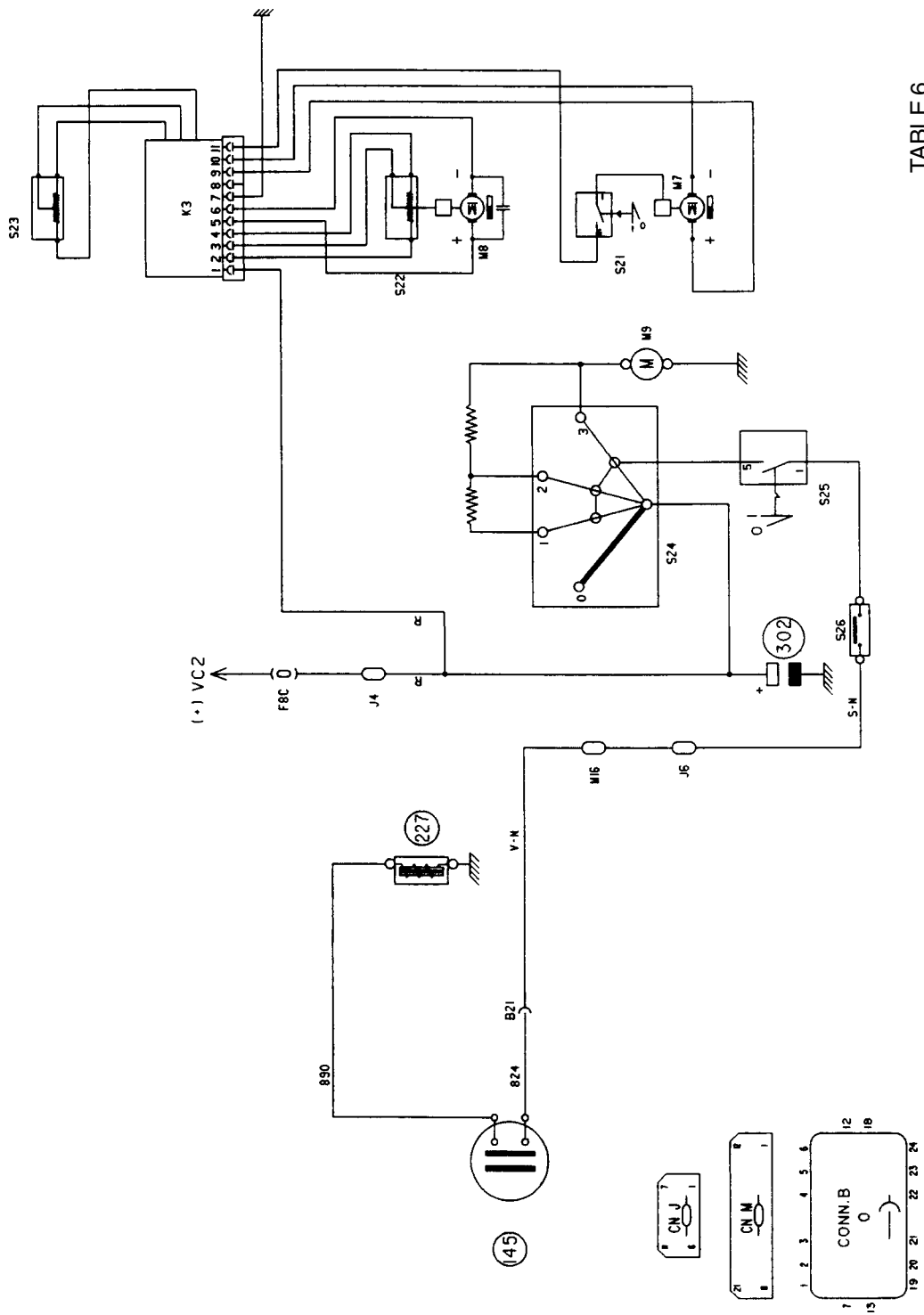
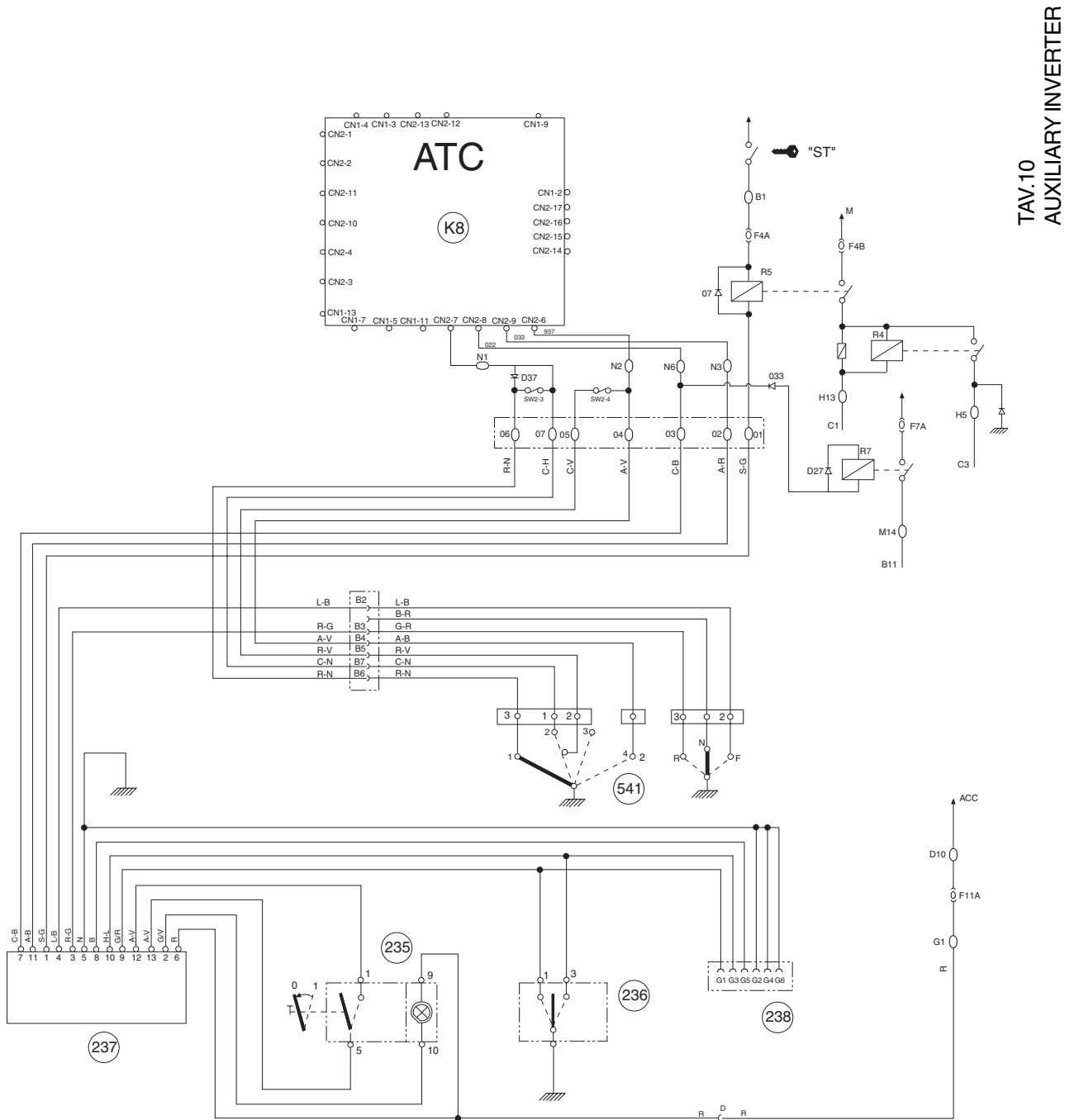

TABLE 6
AIR CONDITIONING
AND VENTILATION



Glass assembly

1. Position the glass in its seat slightly pressing it.

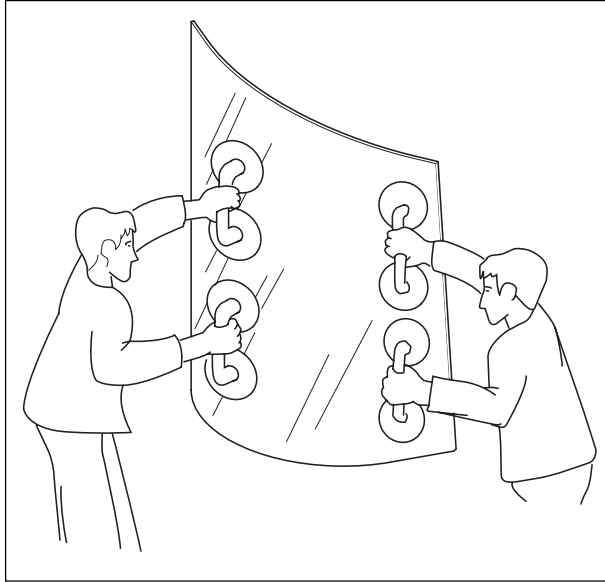

Fig. 8-20

Note - The glass must be fitted to the machine within maximum 15 minutes after applying the BETASEAL sealant-adhesive.

Note - Work only in well ventilated premises. The polyurethane adhesive does not contain low molecular weight (monomolecular) volatile isocyanates. Therefore, there is no danger of irritation for the respiratory tract. However, all precautions required when using chemicals should be observed. Avoid contact with the eyes and skin.

Note - The BETASEAL sealant-adhesive hardens with air moisture. Hardening depends upon ambient humidity and relative penetration degree. Therefore, machine downtime ranges from 2 to 3 hours at a temperature of 23°C. During this period the machine should not be submitted to any stress whatever.



WARNING

Any variation to instructions specified, such as use of materials after expire date or improper work procedures, may negatively affect the results of the operation. The manufacturer does not assume any responsibility for damages which may derive to persons and/or things.

8.7 TROUBLESHOOTING

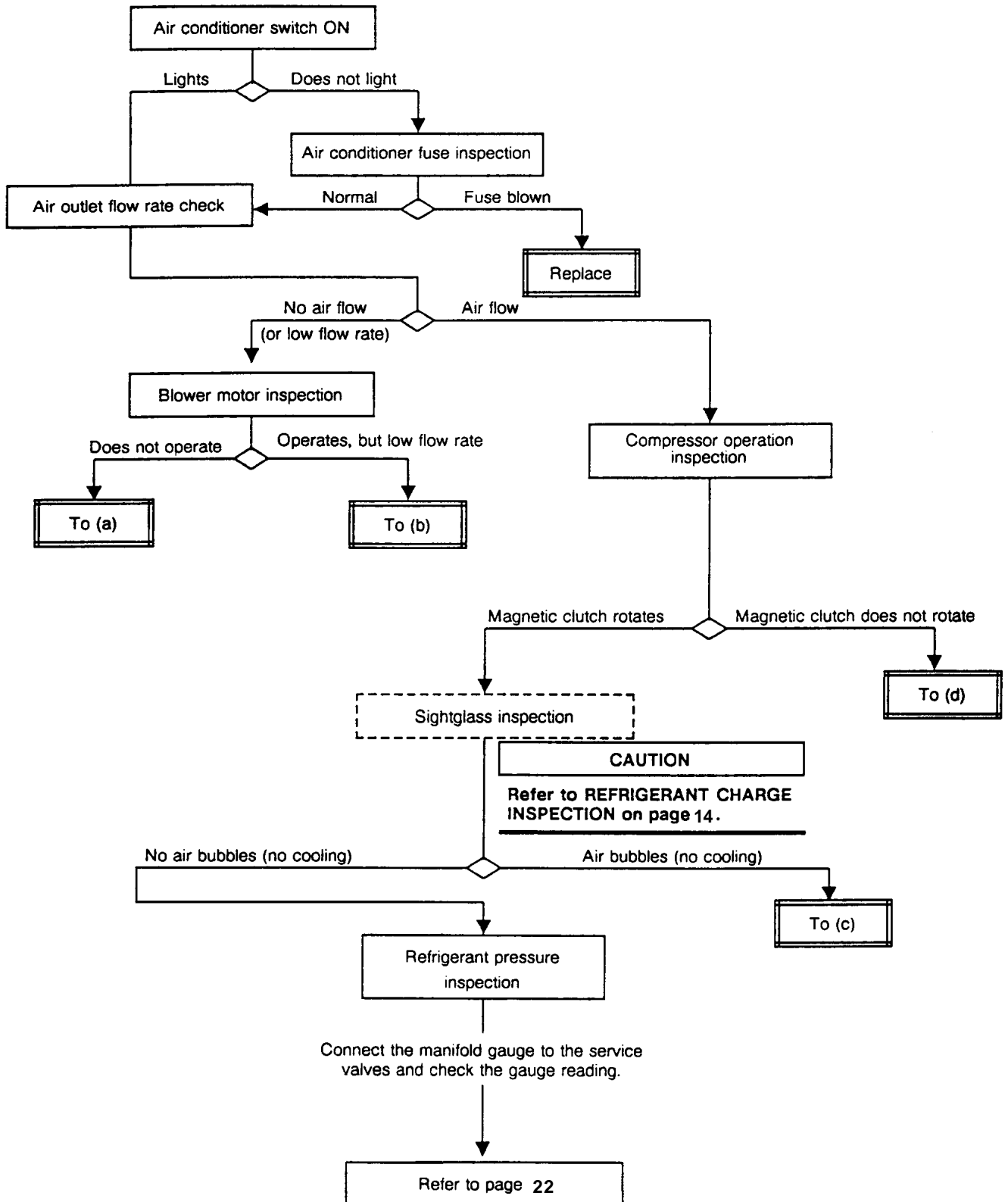

CLICK HERE TO **DOWNLOAD** THE COMPLETE MANUAL

- Thank you very much for reading the preview of the manual.
- You can download the complete manual from: www.heydownloads.com by clicking the link below



- Please note: If there is no response to CLICKING the link, please download this PDF first and then click on it.

CLICK HERE TO **DOWNLOAD** THE COMPLETE MANUAL