

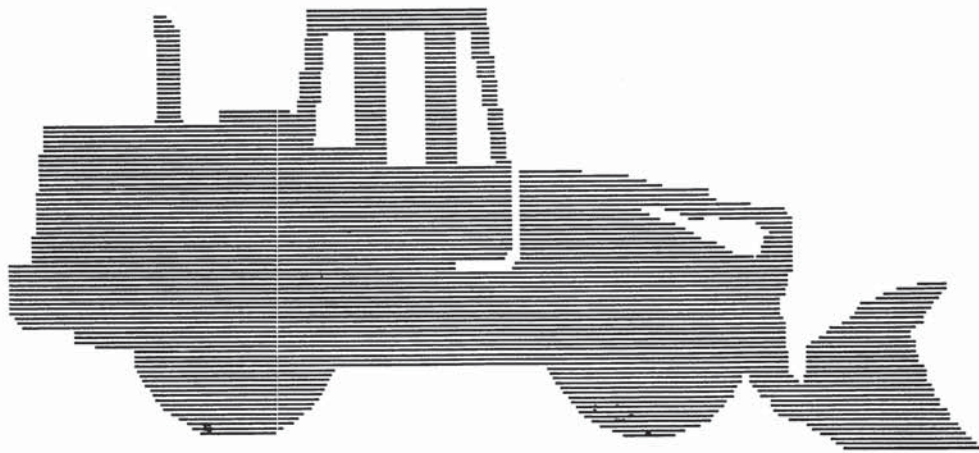

FR220

Wheel Loader



Service Manual

CLICK HERE TO **DOWNLOAD** THE COMPLETE MANUAL

- Thank you very much for reading the preview of the manual.
- You can download the complete manual from: www.heydownloads.com by clicking the link below



- Please note: If there is no response to CLICKING the link, please download this PDF first and then click on it.

CLICK HERE TO **DOWNLOAD** THE COMPLETE MANUAL

SAFETY RULES

Never travel a machine on a job site, in a congested area, or around people without a signal person to guide the operator.

In darkness, check area of operation carefully before moving in with machine. Use all lights provided. Do not move into area of restricted visibility.

Maintain clear vision of all areas of travel or work. Keep cab windows clean and repaired. Carry blade low for maximum visibility while traveling. Obtain and use fan blast deflectors where tractors are used as pusher tractors in tandem.

Transport a loaded bucket with the bucket as far tipped back and in as low a position as possible for maximum visibility, stability, and safest transport of the machine. Carry it at a proper speed for the load and ground conditions.

Carry the bucket low when traveling with a load.

Maintain a safe distance from other machines. Provide sufficient clearance for ground and visibility conditions. Yield right-of-way to loaded machines.

Avoid going over obstacles such as rough terrain, rocks, logs, curbs, ditches, ridges, and railroad tracks whenever possible. When obstructions must be crossed, do so with extreme care at an angle if possible. Reduce speed - down-shift. Ease up to the break over point - pass the balance point slowly on the obstruction and ease down on the other side.

Cross gullies or ditches at an angle with reduced speed after insuring ground conditions will permit a safe traverse.

Be alert to soft ground conditions close to newly constructed walls. The fill material and weight of machine may cause the wall to collapse under the machine.

Operate at speeds slow enough to insure complete control at all times. Travel slowly over rough ground, on slopes or near drop offs, in congested areas or on ice or slippery surfaces.

Be alert to avoid changes in traction conditions that could cause loss of control. **DO NOT** drive on ice or frozen ground conditions when working the machine on steep slopes or near drop offs.

Keep the machine well back from the edge of an excavation.

Be especially careful when traveling up or down slopes. Position the bucket in such a way as to provide a possible anchorage on the ground in case of a slide.

When proceeding across a hill side proceed slowly. Never turn sharply up hill or down hill.

Avoid side hill travel whenever possible. Drive up and down the slope. Should the machine start slipping sideways on a grade, turn it immediately downhill.

In steep down hill operation, do not allow engine to over speed. Select proper gear before starting down grade.

There is no substitute for good judgement when working on slopes.

The grade of slope you should attempt will be limited by such factors as condition of the ground, load being handled, the type of machine, speed of machine and visibility.

NEVER COAST the machine down grades and slopes with the transmission in neutral on power shift machines, or clutch disengaged on manually shifted machines.

To reduce the danger of uncontrolled machine, choose a gear speed before proceeding down grade that will hold machine to proper speeds for conditions.

Operating in virgin rough terrain that includes previously mentioned hazards is called pioneering. Be sure you know how this is done. Danger from falling branches and upturning roots is acute in these areas.

When pushing over trees, the machine must be equipped with proper over head guarding. Never allow a machine to climb up on the root structure particularly while the tree is being felled. Use extreme care when pushing over any tree with dead branches.

Avoid brush piles, logs or rocks. **DO NOT DRIVE THE MACHINE ONTO BRUSH PILES, LOGS, LARGE ROCKS** or other surface irregularities that break traction with the ground especially when on slopes or near drop offs.

Avoid operating equipment too close to an over hang or high wall either above or below the machine. Be on the look out for caving edges, falling objects and slides. Beware of concealment by brush and under growth of these dangers.

Park in a non-operating and non-traffic area or as instructed. Park on firm level ground if possible. Where not possible, position machine at a right angle to the slope, making sure there is no danger of uncontrolled sliding movement. Set the parking brake.

Never park on an incline without carefully blocking the machine to prevent movement.





If parking in traffic lanes cannot be avoided, provide appropriate flags, barriers, flares and warning signals as required. Also provide advance warning signals in the traffic lane of approaching traffic.

Move the machine away from pits, trenches, overhangs and over head power lines before shutting down for the day.

When stopping operation of the machine for any reason, always return the transmission or hydrostatic drive control to neutral and engage the control lock to secure the machine for a safe start up. Set parking brake, if so equipped.

Never lower attachments or tools from any position other than seated in operator's seat. Sound the horn. Make sure the area near the attachment is clear. Lower the attachment slowly. **DO NOT USE** float position to lower hydraulic equipment.

CAPSCREW AND TORQUE VALUES

Capscrew Head Markings	SAE Grade Number	Capscrew Size									
		1/4	5/16	3/8	7/16	1/2	9/16	5/8	3/4	7/8	1
 1 or 2		20	18	16	14	13	12	11	10	9	8
		28	24	24	20	20	18	18	16	14	14
 5		5	11	18	28	39	51	83	105	160	235
		6	13	20	30	41	55	95	115	175	250
 6 or 7		8	17	31	49	75	110	150	270	395	590
		10	19	35	55	85	120	170	295	435	660
 8		10	19	34	55	85	120	167	280	440	660
		12	21	38	61	95	130	187	300	480	730
		12	24	44	70	105	155	210	375	605	910
		14	27	49	78	120	170	240	420	675	990

Manufacturer's marks may vary

Torque Ft-Lb

Threads per inch

Notes:

1. Always use the torque values listed above when specific torque values are not available.
2. Do not use above values in place of those specified in other sections of this manual; special attention should be observed.
3. The above is based on use of clean, dry threads.
4. Reduce torque by 10% when engine oil is used as a lubricant.
5. Reduce torque by 20% if new plated capscrews are used.
6. Capscrews threaded into aluminum may require reductions in torque of 30% of more of Grade 5 capscrews torque and must attain two capscrew diameters of thread engagement.

CAUTION: If replacement capscrews are of a higher grade than originally supplied, adhere to torque specifications for that replacement.

GENERAL

ELECTRICAL SYSTEM

24 Volts

Alternator

With incorporated electronic voltage regulator.

Starter Motor

Automatic pinion engagement by solenoid.

Battery

Two, 12V, series-connected.

CAB

Modular construction, elastically suspended, integrated ROPS cab. The cab ensures top interior comfort whatever the outdoor climatic conditions.

WEIGHT AND SPEED

Operating weight with 26.5 x 25 tires, 3.6 cu. m. (4.7 cu. yd.) bucket, operator and full fuel tank:
21,560 Kg. (47,540 lbs)

Max speeds (forward-reverse) (with size 26.5 x 25 tires):

Speeds	I	II	III	IV
- forward Km/h mph.	6.7 4.1	11.1 6.9	21.2 13.1	32.6 20.2
- reverse Km/h mph.	6.7 4.1	11.1 6.9	21.2 13.1	- -

ACCESSORY EQUIPMENT

Some of the equipment items described and illustrated are supplied to certain markets to meet specific requirements.

Other special devices and attachments are also available as optional equipment. Check with the Sales Organization.

DIMENSIONAL DATA (in mm)

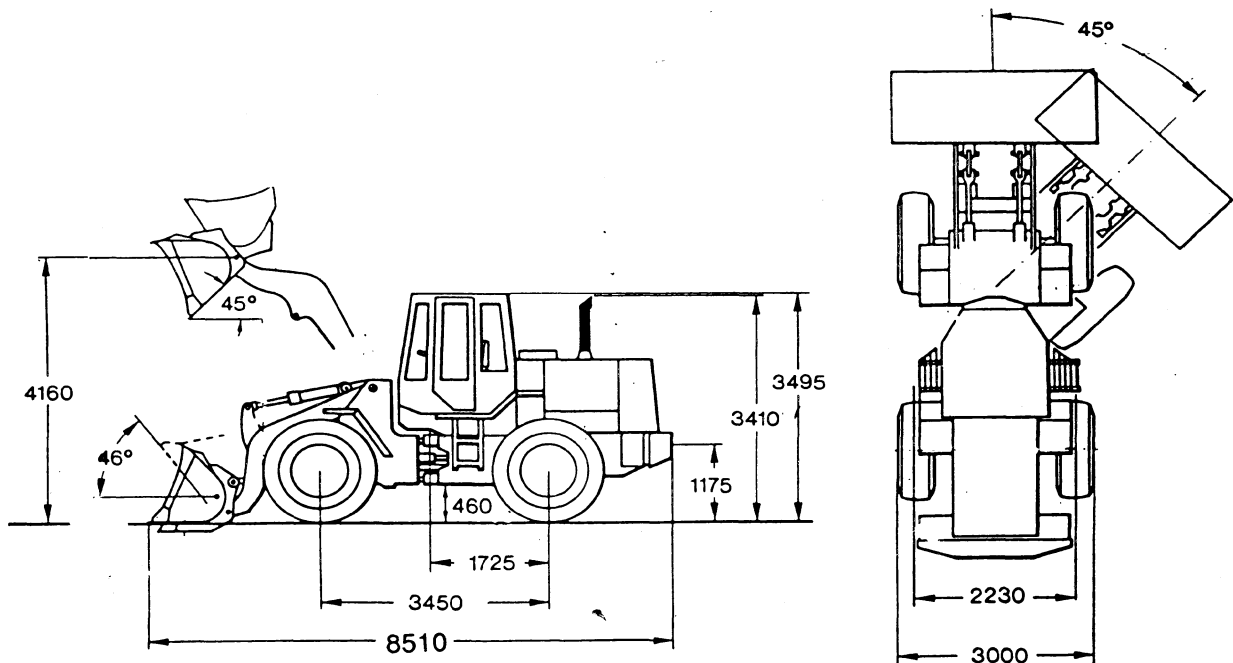

Study SAFETY RULES in the front of this manual thoroughly for the protection of machine and safety of personnel.

3.2 TROUBLESHOOTING

Lubricant Loss	Lubricant leaks at planetary cover		Examination	Tighten capscrews or reseal cover and capscrews
	Lubricant level too high		If oil blows from breather, check oil level	Fill differential to proper level
	Excessive foaming of lubricant		Examination	Drain and fill with correct lubricant
	Breather plugged		Examination	Clean breather
	Damaged seals		Examination	Replace
Lubricant Loss	Worn yoke		If oil leaks from yoke may be seals or yoke	Replace seal or yoke
Overheating	Incorrect lubricant or level incorrect		Examination	Check level, fill with correct lubricant
	Excessive gear wear		Examination	Replace gears
	Pinion gear assembly adjusted too tight in the differential		Examination	Correct to proper adjustment

Study SAFETY RULES in the front of this manual thoroughly for the protection of machine and safety of personnel.

3.4 REPAIR PROCEDURES

3.4.2 REAR AXLE SUPPORT DISASSEMBLY

3.4.2.1

Remove the capscrews holding the cover to the axle oscillating support.

NOTE: Attach a hoist and sling to axle support before removing cover capscrews as these capscrews also hold support pivot hub to axle housing.



WARNING

Lift and handle all heavy parts with a lifting device of proper capacity. Be sure parts are supported by proper slings and hooks. Use lifting eyes if provided. Watch out for people in the vicinity.

3.4.2.2

Remove cover and shims.

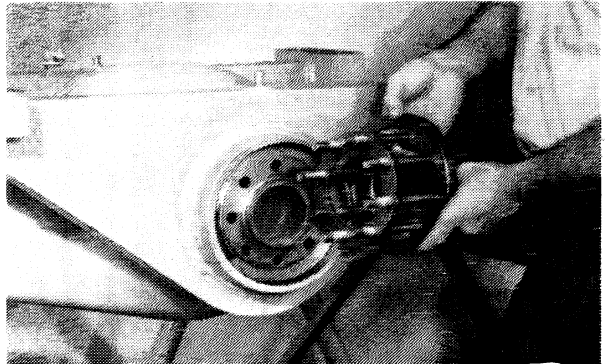
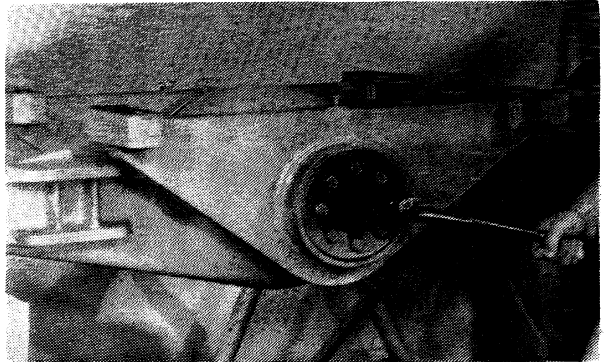

3.4.2.3

Remove outer spacer.

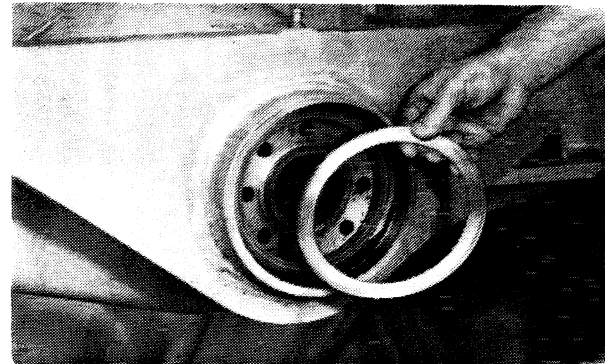

3.4.2.4

Remove rear oscillation support by lifting the support and pulling.

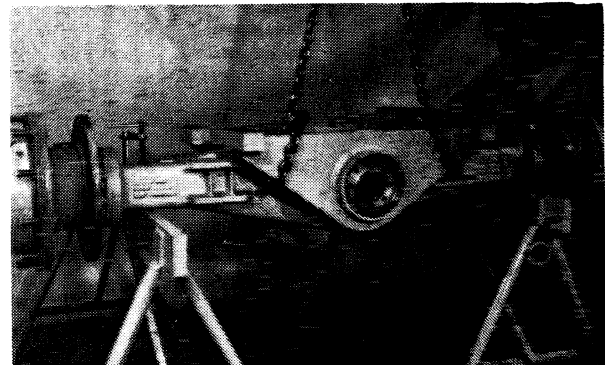

3.4 REPAIR PROCEDURES

3.4.3.32

Remove gears. No gear can be removed unless all of them are loose.

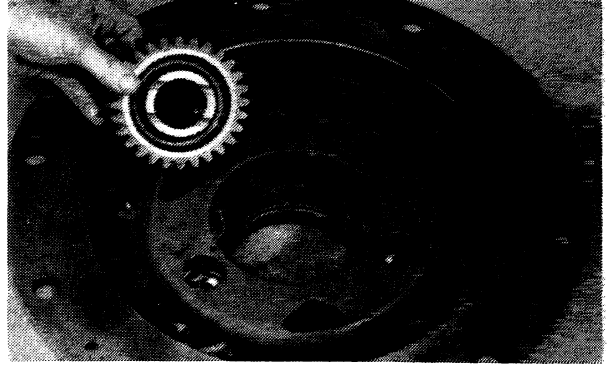

3.4 REPAIR PROCEDURES

3.4.4.36
Remove other side gear.

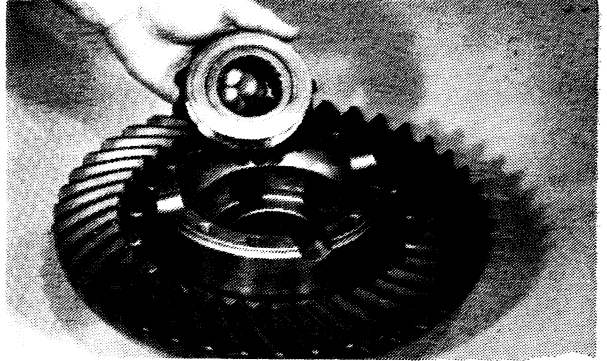

3.4.4.37
Remove bearings from case halves with a split bearing puller.

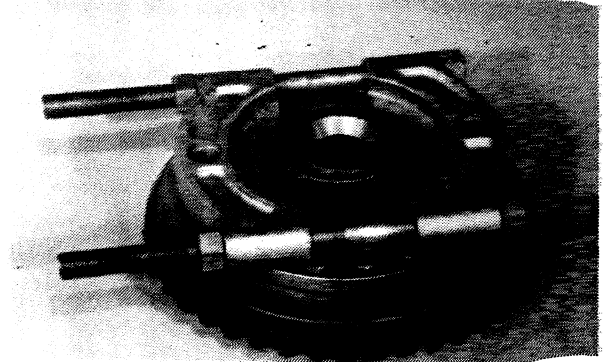

3.4.4.38
Secure bevel gear in vise that has soft jaws. Remove capscrews holding gear to case.

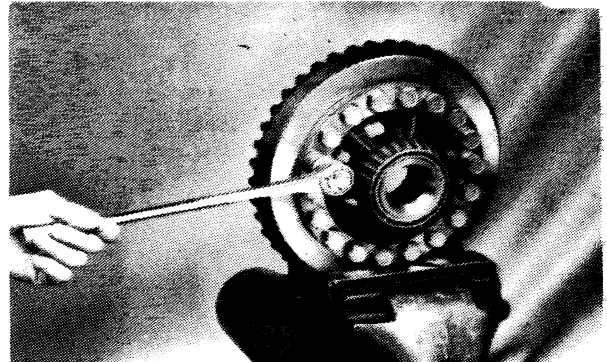

3.4 REPAIR PROCEDURES

3.4.5.25

Check side gear end play on both sides of differential in 4 places 90° apart. The average of the 4 readings should be 0.05-0.10 mm (.002"-.004").

Note: If average reading is not within specifications, one or more of disc(A) will have to be replaced. Disc(A) is available in 4 thicknesses to obtain the proper stack height.

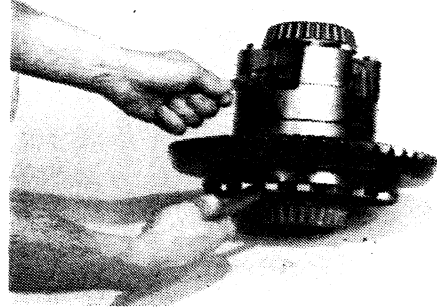

3.4.5.28

Heat inner bearing to 121°C (250°F); install on pinion.

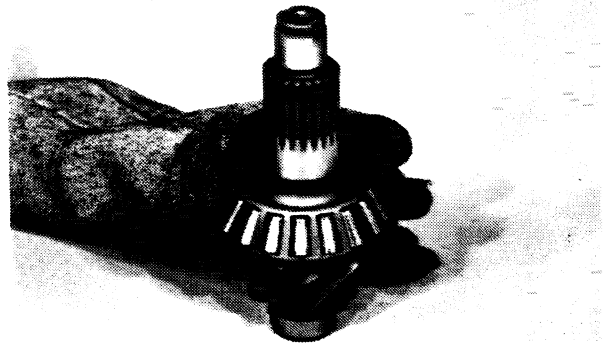

Study SAFETY RULES in the front of this manual thoroughly for the protection of machine and safety of personnel.

3.4 REPAIR PROCEDURES

3.4.5.65

Lower differential into axle housing.

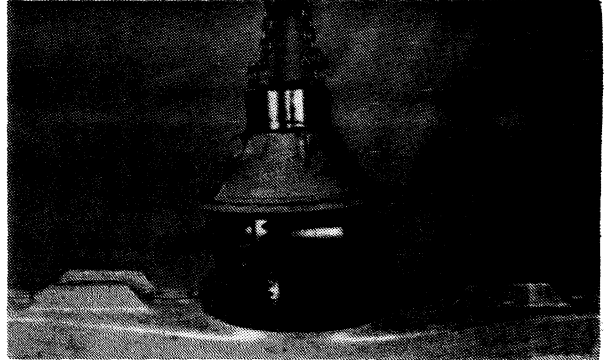

3.4.5.66

Tighten capscrews to specified torque.

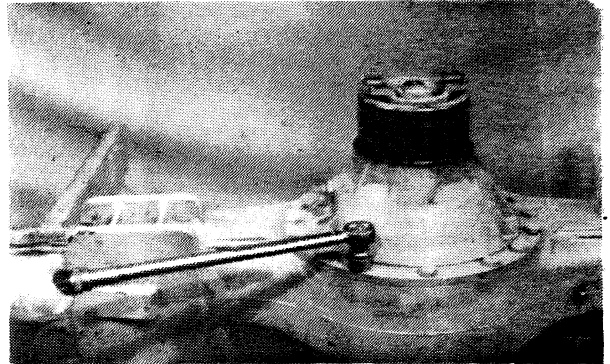

Study SAFETY RULES in the front of this manual thoroughly for the protection of machine and safety of personnel.

3.4 REPAIR PROCEDURES

3.4.7.5
Install outer thrust ring.

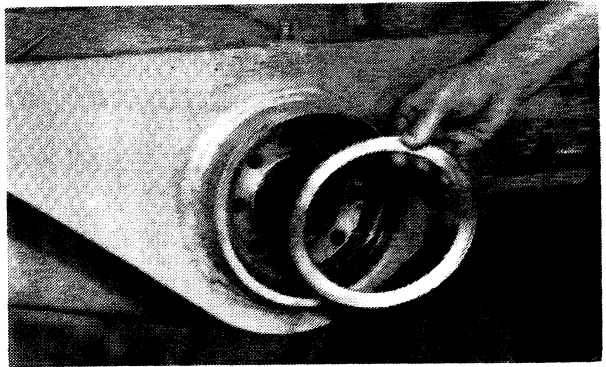

3.4.7.6
Temporarily clamp support to axle.

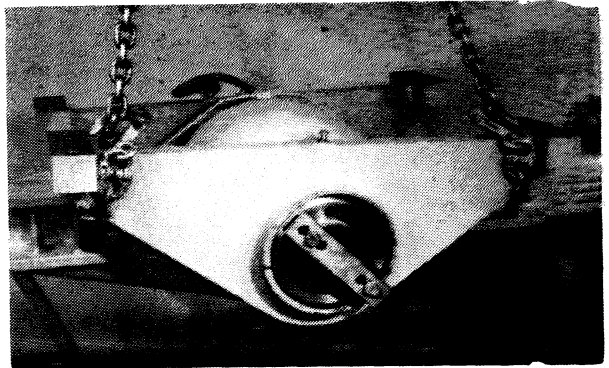

3.4.7.7
Measure from bolt circle face to thrust ring. Dimension A.

Example: 2.4 mm (0.095")

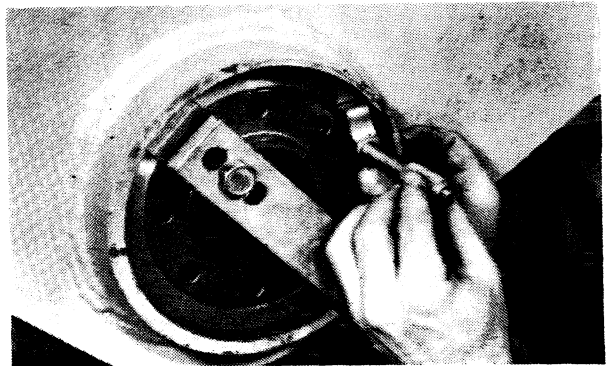

3.4.7.8
Measure depth of counterbore in retaining cover flange. Dimension B.

Example: 5.1 mm (0.201")



Study SAFETY RULES in the front of this manual thoroughly for the protection of machine and safety of personnel.

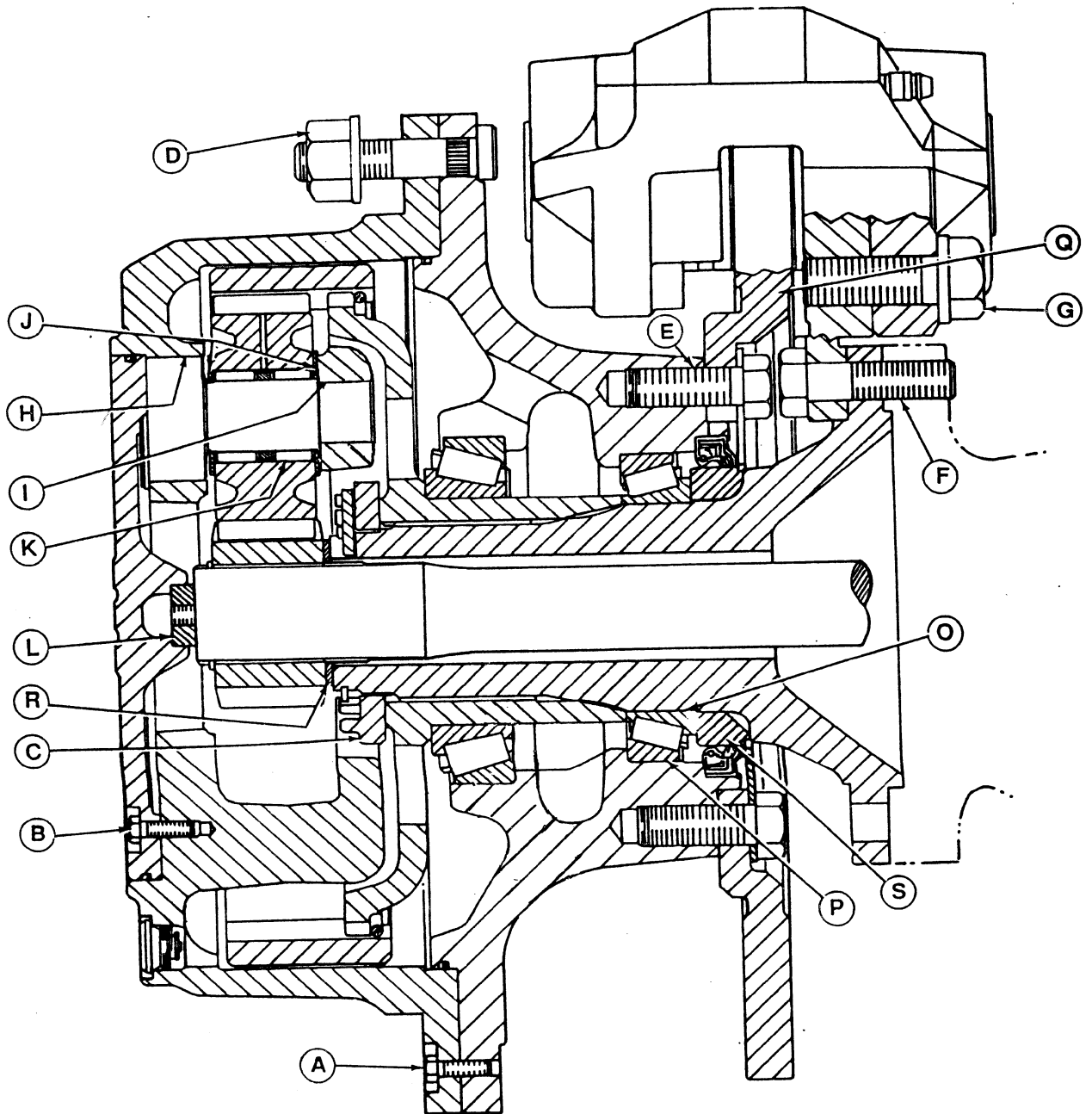

REAR AXLE PLANETARY WHEEL END

Study SAFETY RULES in the front of this manual thoroughly for the protection of machine and safety of personnel.
3-75

4.1 GENERAL DESCRIPTION

BRAKE SCHEMATIC

SCHEMATIC: ENGINE NOT RUNNING

The system contains the following components: four accumulators [two brake accumulators(1,2); one parking brake accumulator(16); one damper accumulator(2)]; two brake circuit pressure control valves(6,8); four check valves; [three accumulator check valves(5,12,21); and one main check valve(23)] unloader valve(25); pilot valve(19); pilot valve unseating piston(18); brake master cylinder booster(14); brake fluid reservoirs(4); wheel calipers(24); brake light switch(3); low system pressure switch(17); clutch cut-off switch(13); parking brake assembly(27); parking brake control valve(15); brake system supply pump(26).

The brake system uses a gear, fixed displacement type pump, mounted on the engine timing gear housing.

The unloader valve (25), pilot valve(19) and unseating piston (18) work together to control system pressure. They cause the pump to unload and re-circulate to the implement manipulator system when a given pressure is reached in the system. As system pressure decreases, the unloader(25) seats and the pump charges the system. This action is repeated during machine operation.

The main check valve(23) seats during pump unloading cycle. It traps the pressurized oil in the accumulator brake valve circuits and parking brake circuit.

The brake valve's spools (6,8) control the pressure between the brake accumulators(1,7) and master cylinder boost pistons(9).

The brake accumulators and their associated check valves maintain and supply pressurized oil to the brake valves and master cylinder boost pistons, either for normal brake apply or dead engine brake apply.

The damper accumulator(23) stabilizes the pressure in the unseating piston cavity.

The parking brake accumulator(16) and check valve(21) supply pressurized oil to release the parking brake.

The parking brake control valve(15) directs oil from the parking brake accumulator(16) to the parking brake release cylinder(27).

The parking brake assembly has a spring which applies the parking brake and a cylinder to release the parking brake by overcoming the spring.

The master cylinder(14) contains two boost pistons(9) which receive pressurized oil from the brake valves and two pistons (10,11) that pressurize the brake fluid in the caliper circuits.

The brake fluid reservoirs(4) supply the master cylinder caliper circuits.

ENGINE RUNNING, SYSTEM CHARGING

When the engine is started the pump flow(26) enters the brake valve at the unloader valve cavity(25). The pump flow unseats and flows through the main check valve(23). The oil unseats and flows through the accumulator check valves(5,12,21) and charges the brake and parking brake accumulators(1,7,16). Oil is blocked at the brake valves(6,8). Oil flows through the orifice in the unloader valve(25) and charges the pilot valve(19) spring cavity. The spring plus the pressurized oil hold the pilot valve seated.

The master cylinder boost pistons'(9) oil is indexed to sump at the brake valves. The parking brake is applied by the spring, as oil from the release piston is indexed to sump through the parking brake control valve.

SYSTEM CHARGED, PUMP UNLOADING

When the specified pressure is reached in the system, the pressure acting on the unseating piston(15) overcomes the pressure and spring force acting on the pilot valve(19). The pilot valve is unseated allowing the oil in the pilot valve and unloader valve(25) spring cavities to be sumped through the pilot valve seat area. This allows the unloader valve to move and index pump flow to the implement manipulator system (29).

The instant the pump starts to unload, the main check valve(23) seat and traps the pressurized oil in the brake valves and parking brake circuits.

Due to leakage in the brake valves and the parking brake valve, pressure gradually decreases. When the pressure decreases to a specific value, the pilot valve(19) will seat, causing the unloader valve(25) to move and cover the sump port. The main check valve(23) will open and the pump(26) will again charge the circuits. As the pressure increases the unloading cycle will be repeated.

The design of the system allows the pump to be unloaded except for the time it takes to pressurize the system, reducing the load on the engine.

4.4 REPAIR PROCEDURES

4.4.2.1 BRAKE TREADLE VALVE

4.4.2.1.1

The brake treadle valve, located below the operator's platform on the left side of the loader, can be resealed but no spools can be interchanged within the valve.

Turn off the electrical master switch.



DANGER

Always turn the master switch to the off position before cleaning, repairing, servicing or parking the machine to prevent injury.



4.4.2.1.2

Drain the implement oil tank.



DANGER

Fluid under pressure - turn cap or cover slowly to relieve pressure before removing.



4.4.2.1.3

Remove skirting from bottom edge of operator's platform.

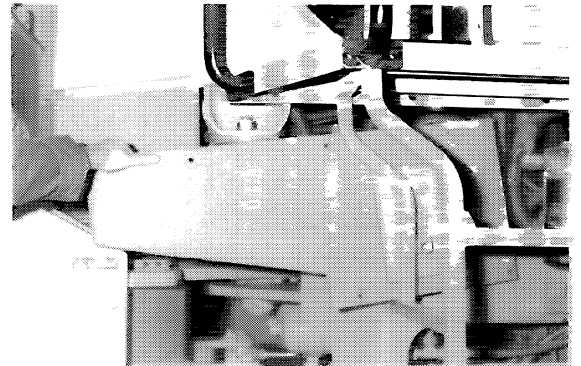

4.4.2.1.4

Remove pressure in brake accumulators by applying brake pedal and parking brake lever several times. This must be done with the engine off.



Study **SAFETY RULES** in the front of this manual thoroughly for the protection of machine and safety of personnel.

4.4 REPAIR PROCEDURES

4.4.2.2.29
Remove two (2) pilot valve springs, (one small, one large).

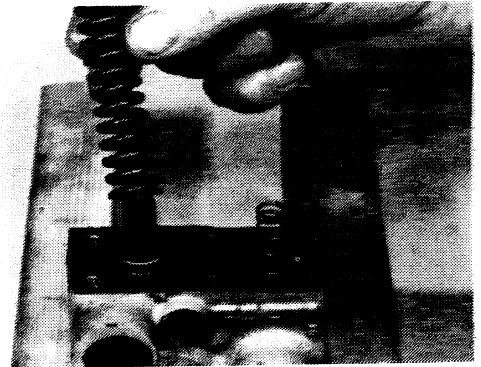

4.4.2.2.30
Remove pilot valve.

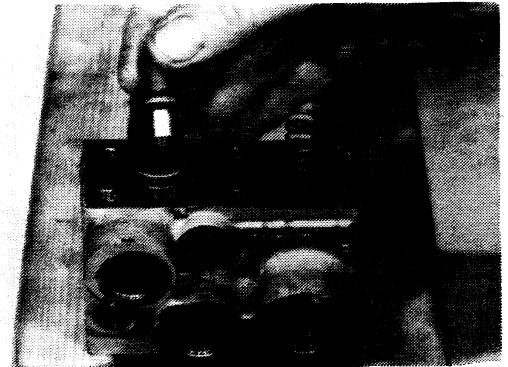

4.4.2.2.31
Remove pilot valve seat.

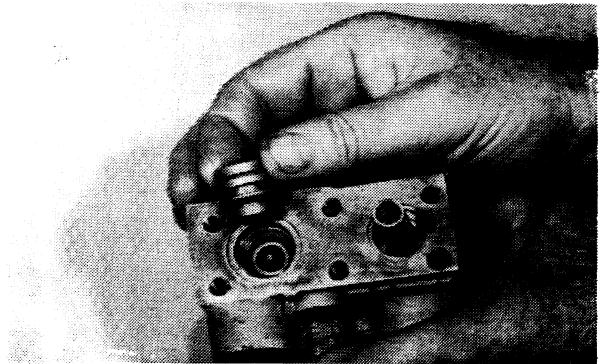

4.4.2.2.32
Remove unloader/relief valve and spring.

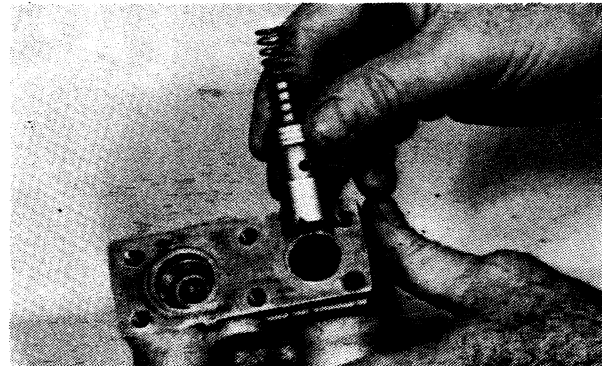

Study SAFETY RULES in the front of this manual thoroughly for the protection of machine and safety of personnel.

4.4 REPAIR PROCEDURES

4.4.4.2.2
Remove brake pads.

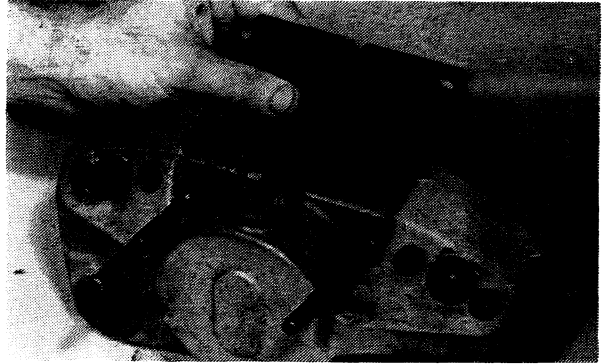

4.4.4.2.3
Use two small screwdrivers and pry out piston. If piston is stuck in bore, clamp opposite piston and attach a hand pump to inlet port to force out piston.

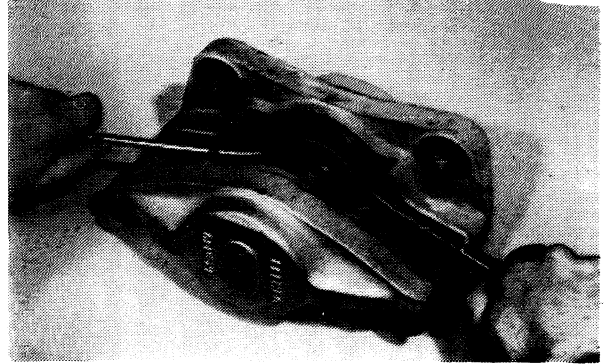

4.4.4.2.4
Remove dust seal.

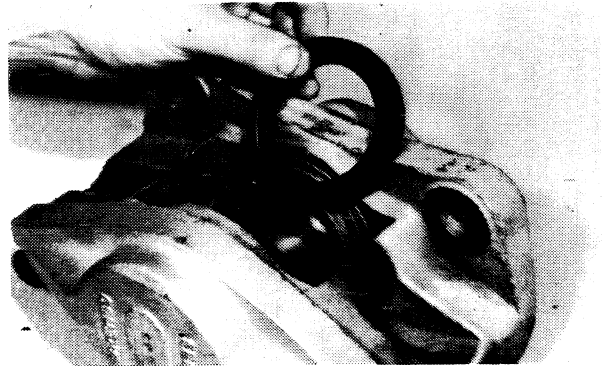

4.4.4.2.5
Remove wiper ring and O-ring.

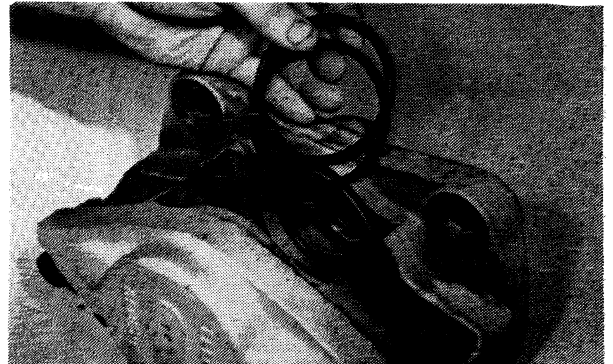

Study SAFETY RULES in the front of this manual thoroughly for the protection of machine and safety of personnel.

4.4 REPAIR PROCEDURE

4.4.6.2.4

Disconnect the brake release hydraulic line.



4.4.6.2.5

Disconnect the parking brake application sensor cable.

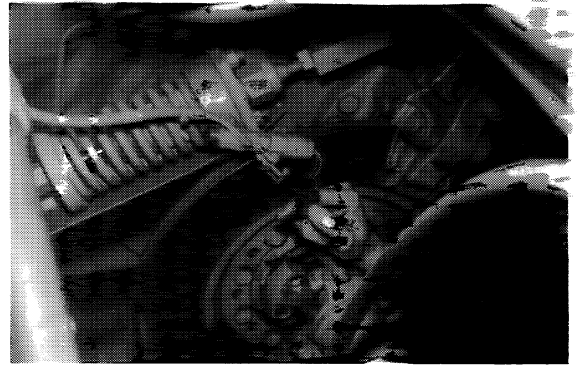

4.4.6.2.6

Remove lock pin and back out a few turns the spring pre-load nut. At the same time, slacken the jam nut and, next, the brake pad release screw.

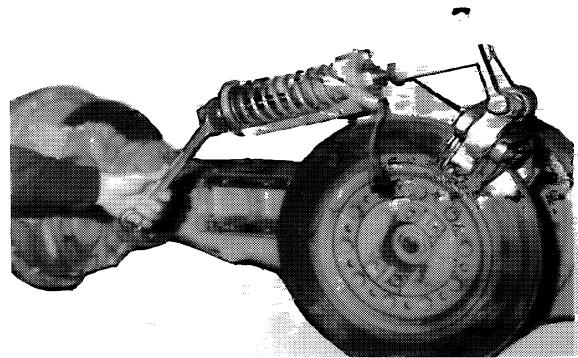

4.4.6.2.7

Remove the brake pad operating lever to spring link pin.

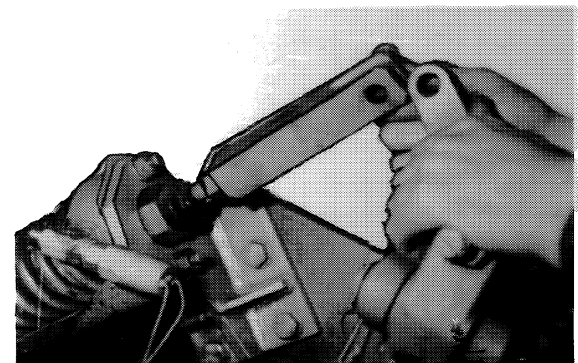

Study SAFETY RULES in the front of this manual thoroughly for the protection of machine and safety of personnel.

5.1 GENERAL DESCRIPTION

STEERING SYSTEM SCHEMATIC

NEUTRAL POSITION

Under this condition, the oil entering the booster shifts spool (11) and feeds the implement control valve through chamber EF.

In this position (NEUTRAL), spool 12 will center on its seat and, consequently, any back-pressure in the circuit caused by wheel bounces or obstacles will be damped through cushion valves (13).

LEFT STEER

Upon turning the steering wheel a signal is sent out by power steering unit (1) and once it reaches the booster the oil in chamber LS pushes down spool (11) thus permitting most of the oil to distribute itself around the booster.

At the same time, the oil issuing from the steering gear unit reaches :

- Spool (12) in chamber L and, through the radial orifices, pushes up spool (12).
- Chamber H and pushes down valve (14) thus permitting main oil flow P to feed the steering control cylinders through ports P1.

BOOSTING STAGE

This stage is governed by valve (14).

Since the pressure in chamber C is the same as the pressure in chamber T, boosting operation will depend upon areas of pilot flow port (F) and main oil flow ports (P).

Area of port F = AP.

Area of ports P = AH.

Ports (F) and (P) will open simultaneously, whereby :

Pilot oil flow = QP.

Main oil flow = QH.

As the pressure drop across the two types of port (F and P) is the same, the following proportions will be obtained:

$$QH/QP = AH/AP = QH$$

$$QH = QP \times AH/AP$$

$$\text{Total flow rate : } QP + QP \times AP = QP (1 + AH/AP)$$

where : $1 + AH/AP = f$ which is the boosting factor.

(In the case of Loader FR220 this factor is $f = 8$).

The return oil from cylinders (7) is controlled by spool (12). When understeer is experienced spool (12) will adjust the return oil flow from the cylinders thus ensuring full steering control under whatever condition.

No back-pressure can be transmitted to the steering gear unit because valve (14) will open only when the pilot pressure in chamber (C) will have increased by the same amount as the pressure in chamber (T).

NOTE - Chamber (T) communicates with the steering cylinders through duct (D).

EMERGENCY STEERING

Should the engine shutdown or turn off while machine is moving, ground drive pump (8) connected with the road wheels) will feed oil to the booster through priority valve (9) thus ensuring the supply of oil needed for the steering action.

Study SAFETY RULES in the front of this manual thoroughly for the protection of machine and safety of personnel.

5.3 TESTING

5.3.1 STEERING RELIEF TEST

5.3.1.1

Whenever the steering system does not respond as it should and steering system pressure is thought to be the problem, a simple pressure check can identify the problem area within a few minutes.

5.3.1.2

Gain access to the left side of the machine.



WARNING

Always turn the master switch to the off position before cleaning, repairing, servicing, or parking the machine to prevent injury.

5.3.1.3

Connect a pressure gauge P/N 75300110 which can withstand 350 bar (5000 psi) to the steering test port.

5.3.1.4

Warm the machine's steering oil system to normal working conditions.



WARNING

Observe all start up and shut down procedures and 'WARNINGS' listed in the operation and maintenance instruction manual.

Do not run engine or machine in closed areas without proper ventilation to remove deadly exhaust gases.

Machine and it's attachments are to be operated only by qualified operator seated in the operator's seat.

Before starting machine, check, adjust and lock the operator's seat for maximum comfort and control of the machine.

Replace seat belts every two years on open canopy units and every three years on machinery with cabs or at change of ownership.

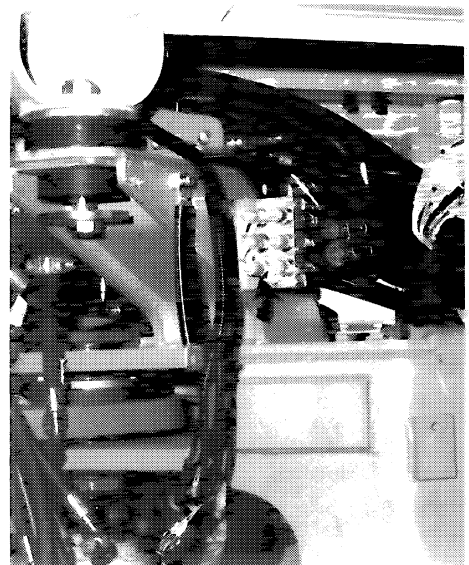

Study SAFETY RULES in the front of this manual thoroughly for the protection of machine and safety of personnel.

5.4 REBUILD PROCEDURES STEERING

5.4.2 FLOW RATE BOOSTER

5.4.2.1

Turn off master switch.

WARNING

Always turn the master switch to the off position before cleaning, repairing, servicing or parking the machine to prevent injury.

Drain the implement oil tank.

DANGER

Fluid under pressure - Turn cap or cover slowly to relieve pressure before removing.

5.4.2.2

Disconnect the hydraulic lines, back out the booster screws and remove valve.

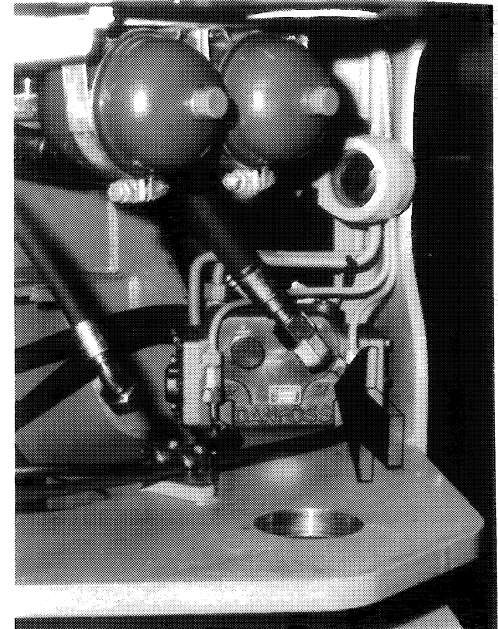
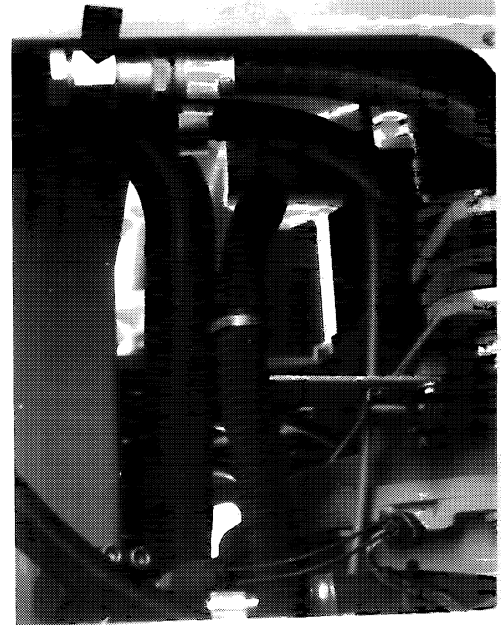

Study SAFETY RULES in the front of this manual thoroughly for the protection of machine and safety of personnel.

CLICK HERE TO **DOWNLOAD** THE COMPLETE MANUAL

- Thank you very much for reading the preview of the manual.
- You can download the complete manual from: www.heydownloads.com by clicking the link below



- Please note: If there is no response to CLICKING the link, please download this PDF first and then click on it.

CLICK HERE TO **DOWNLOAD** THE COMPLETE MANUAL

5.4 REBUILD PROCEDURES

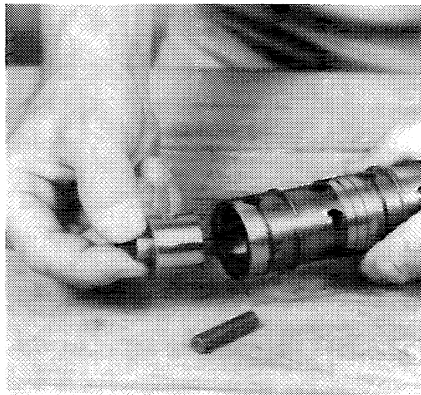

Remove the plug.

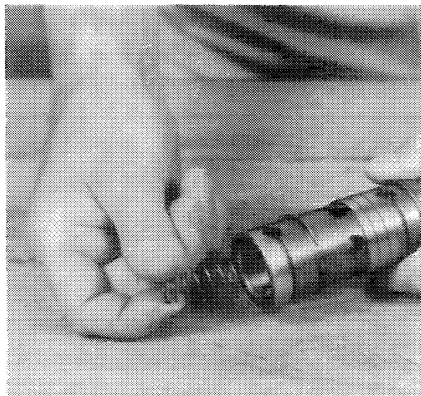

Take out the spring.

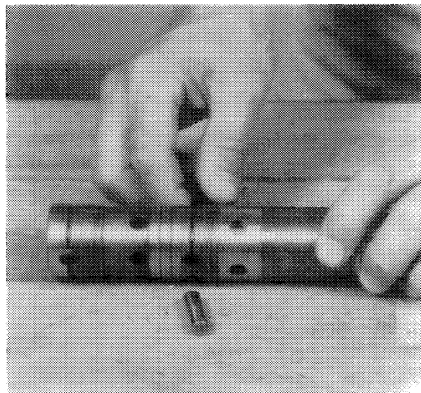

Using a 3 mm screwdriver, backout the pin.

5.4 REBUILD PROCEDURES

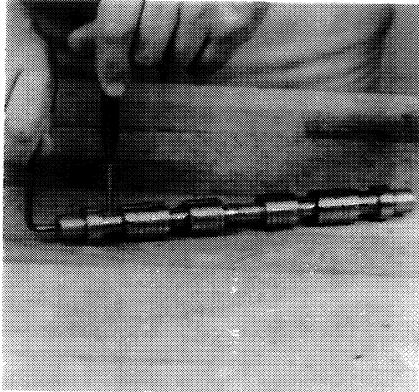

Reassemble the restrictor valve.

SPECIFIED TORQUE : 0.5 daNm

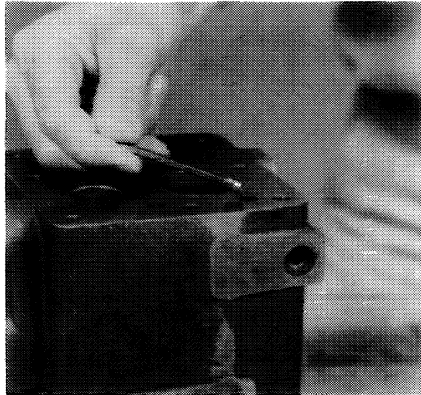

Reassemble the restrictor in housing.

SPECIFIED TORQUE : 0.5 daNm

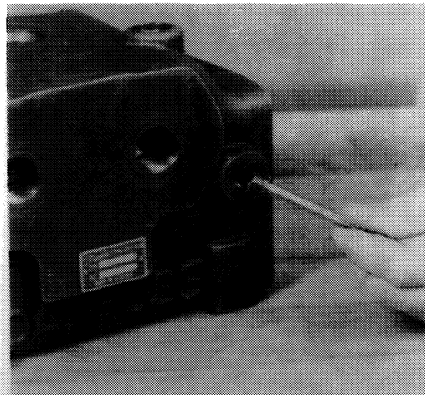

Reassemble the restrictor valve in duct LS.

SPECIFIED TORQUE : 1 daNm

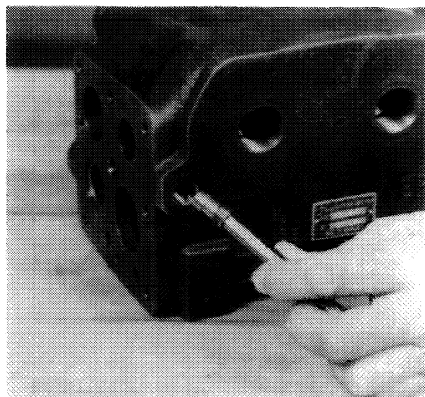

Reassemble the check valve in duct PP.

SPECIFIED TORQUE : 1 daNm

5.4 REBUILD PROCEDURES STEERING

5.4.3.2.17
Remove gerotor inner gear.

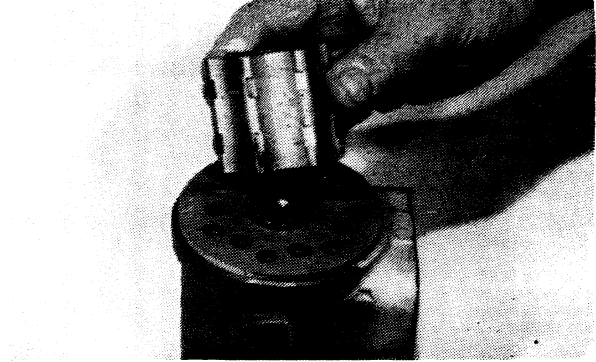

5.4.3.2.18
Remove the drive.

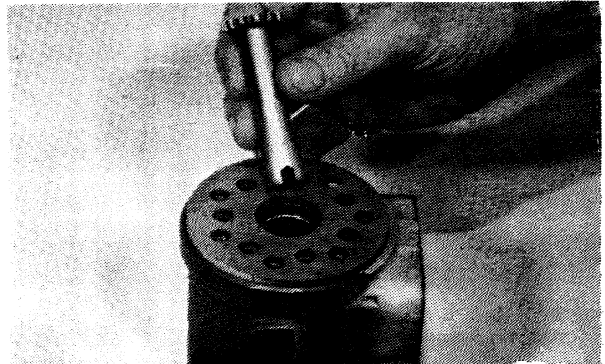

5.4.3.2.19
Remove the spacer.

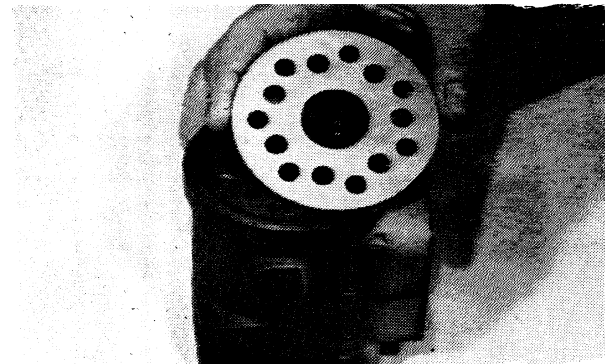

5.4.3.2.20
Remove the check ball retaining screw.

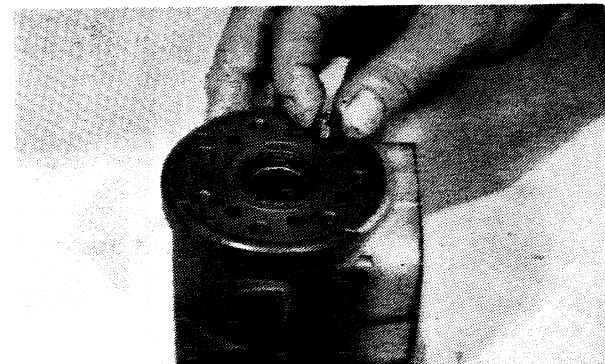

Study SAFETY RULES in the front of this manual thoroughly for the protection of machine and safety of personnel.

5.4 REBUILD PROCEDURES STEERING

5.4.4.13

Use a drift and a hammer to remove the bushing from the cylinder eye.



DANGER

It is unsafe to strike hardened steel parts with anything other than a soft iron or non-ferrous hammer. When installing or removing such parts wear safety glasses with side shields and heavy gloves, etc., to reduce the possibility of injury.

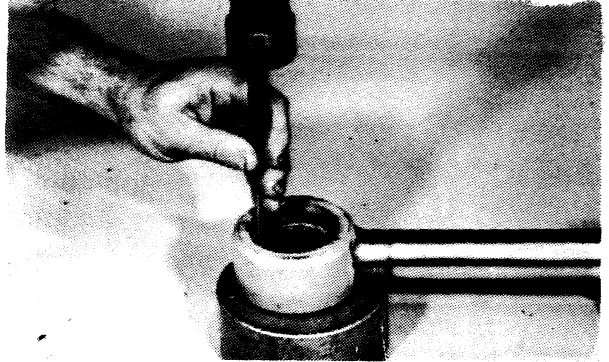

5.4.4.14

Install one snap ring into the cylinder eye. Drive the bushing into the eye and install the other snap ring. Cylinder installation is the reverse of removal. Be sure capscrews are tightened to specified torque.

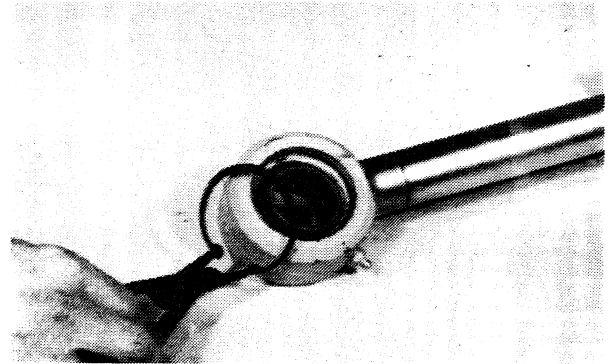

5.4.4.15

Fill the implement oil tank and operate the loader and test for leaks.



WARNING

Do not run the engine of this machine in closed areas without proper ventilation to remove deadly exhaust gasses.

Observe all start up and shut down procedures and "WARNINGS" listed in the operation and maintenance instruction manual.

This machine and its attachments are to be operated only by qualified operator seated in the operator's seat.

Before starting machine, check, adjust and lock the operator's seat for maximum comfort and control of the machine.

Replace seat belts every two years on open canopy units and every three years on machinery with cabs or at change of ownership.

5.4 REBUILD PROCEDURES IMPLEMENT

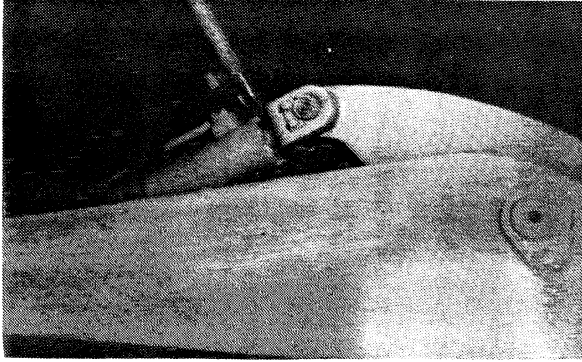

5.4.7.5
Use tool P/N 75300478 to loosen the cylinder head from the cylinder tube.

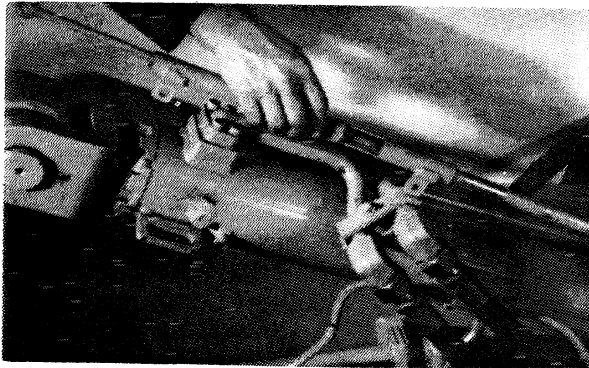

5.4.7.6
Remove the bucket level tube from the cylinder, if necessary.

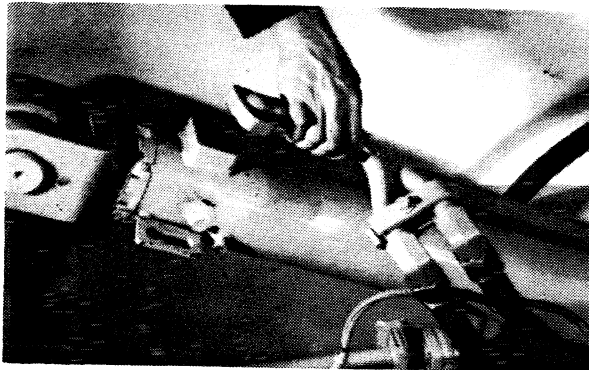

5.4.7.7
Remove oil tubes from the cylinder



5.4.7.8
Remove grease line on the cylinder

Study SAFETY RULES in the front of this manual thoroughly for the protection of machine and safety of personnel.

5.4 REBUILD PROCEDURES IMPLEMENT

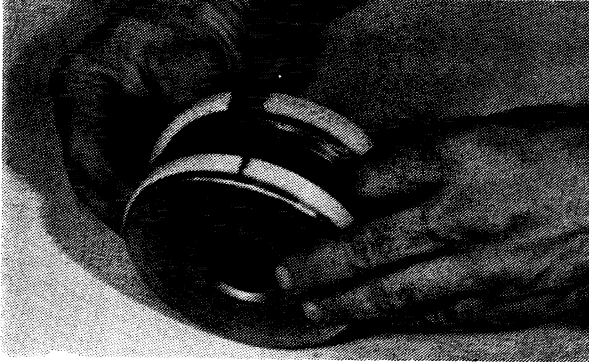

5.4.9.9
Remove the wiper rings from the piston.

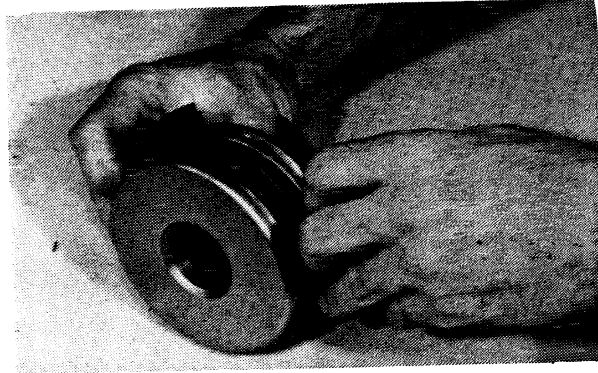

5.4.9.10
Remove the back up rings from the piston seal.



5.4.9.11
Remove the piston seal.

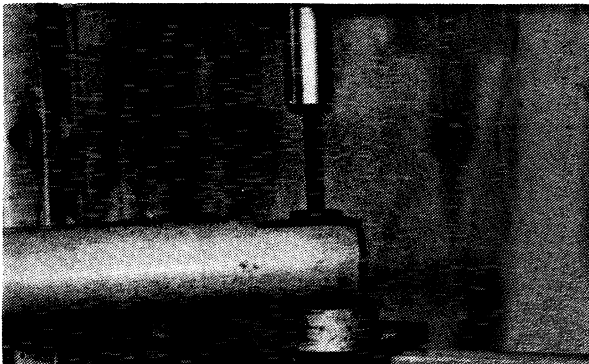

5.4.9.12
Remove the seals and bushings from the end of the tube by pressing the items using a shop press and a plate.

Study SAFETY RULES in the front of this manual thoroughly for the protection of machine and safety of personnel.

5.4 REBUILD PROCEDURES IMPLEMENT

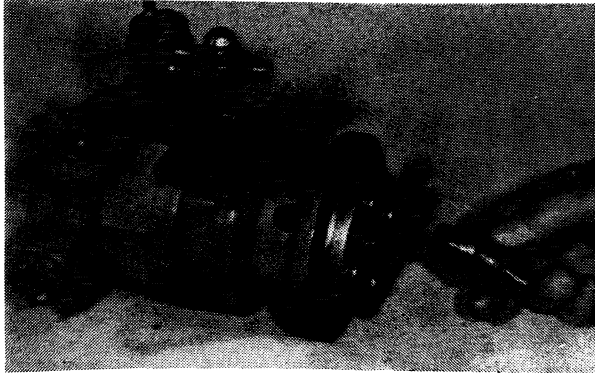

5.4.13.5
Unscrew the articulation joint from the housing.



5.4.13.6
Mark the component parts so that the valve can be placed back in their original positions.

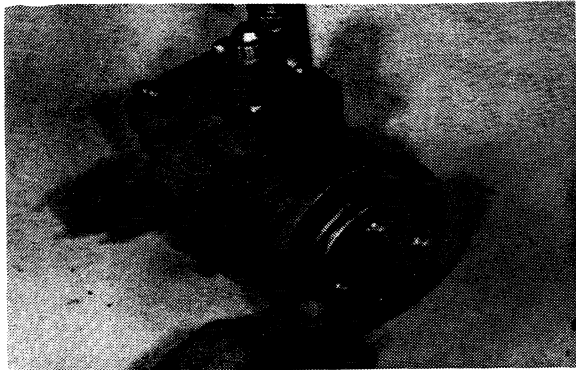

5.4.13.7
Unscrew the plunger housing from the valve housing.

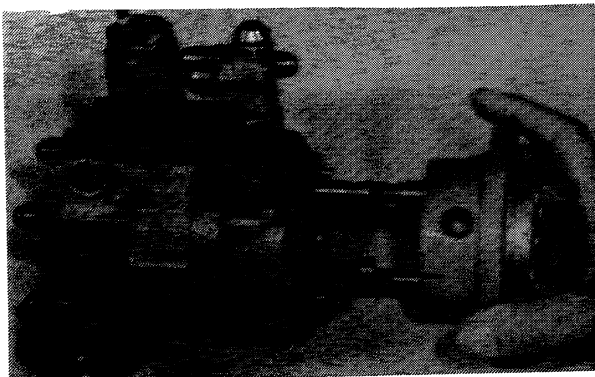

5.4.13.8
Pull the plunger housing away from two of the spools.
The other two spools remain with the plunger housing.

Study SAFETY RULES in the front of this manual thoroughly for the protection of machine and safety of personnel.

5.6.9 AUXILIARY SPOOL

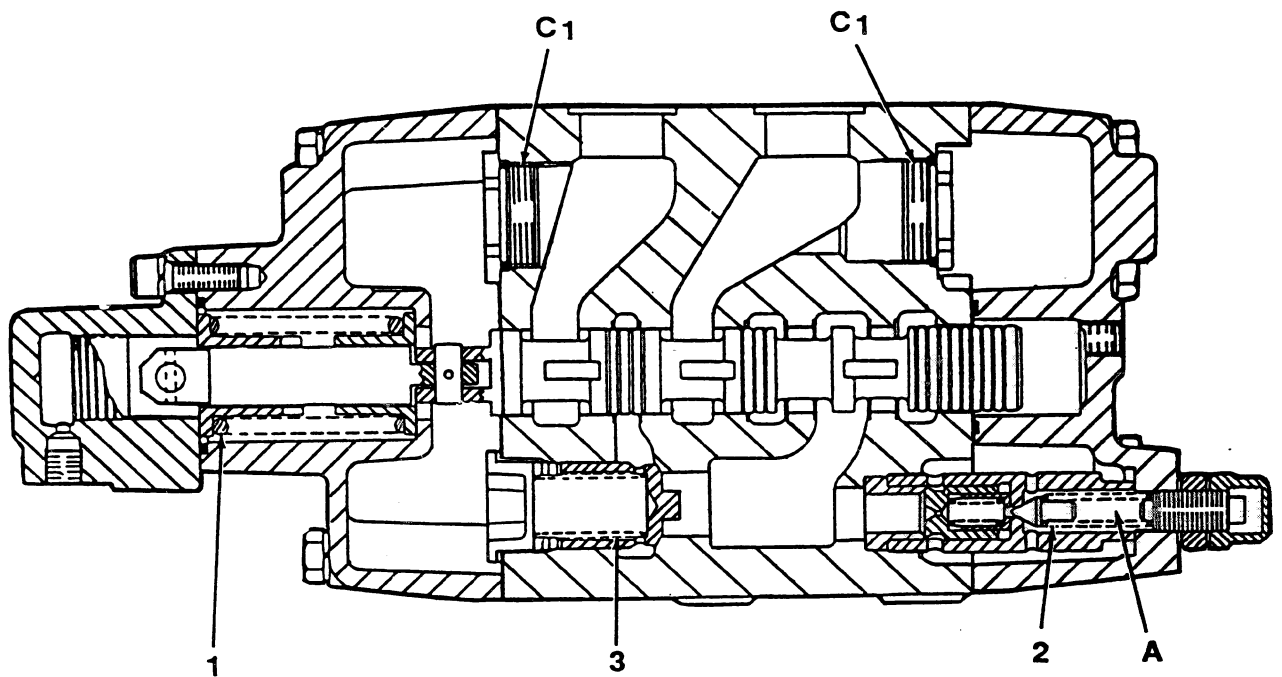

Main relief pressure setting 200 ± 5 bar 2900 ± 70 psi

Capscrew torque daNm ft. lbs.
 C₁ 22-24 162-177

SPRING

1.	Free Length	73.2 mm	2.9"
	Load when compressed to 52 mm (2.04")	182.1-201.3 daN	410-450 lbs.
2.	Free Length	51 mm	2"
	Load when compressed to 43 mm (1.7")	20.1-22.1 daN	44-48 lbs.
3.	Free Length	73 mm	2.9"
	Load when compressed to 40 mm (1.6")	1.8-2.0 Kg	4-4.5 lbs.

Study SAFETY RULES in the front of this manual thoroughly for the protection of machine and safety of personnel.

5.6.19 PILOT REGULATING VALVE

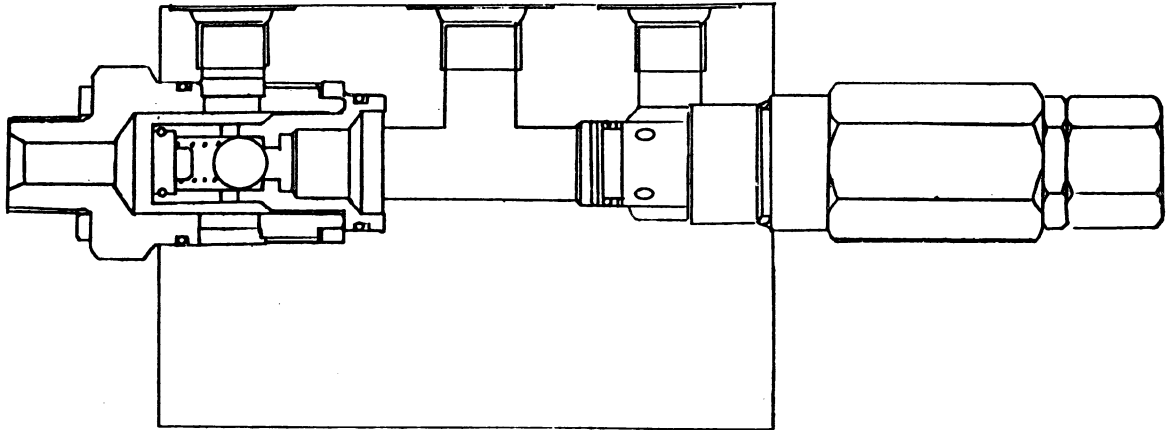

Relief valve setting 30 bar (441 psi)

6.2 HITCH

6.2.1.14
Disconnect electrical wire from horn.



6.2.1.15
Remove clamps securing wiring harness to inside of front frame.

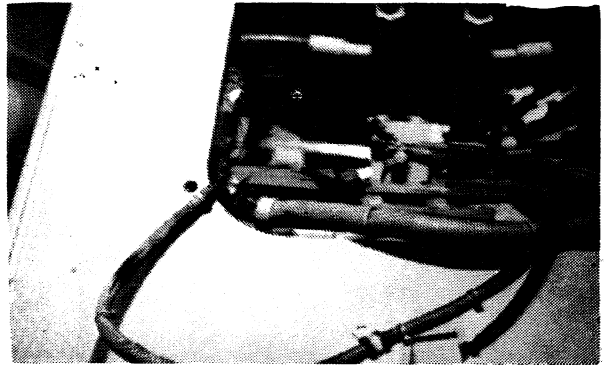

Study SAFETY RULES in the front of this manual thoroughly for the protection of machine and safety of personnel.

6.2 HITCH

6.2.2.12
Connect the brake hose.



6.2.2.13
Reconnect all hydraulic hoses. Make certain implement valve hoses are reconnected in their original position.



6.2.2.14
Attach wiring harness to frame and reconnect horn.

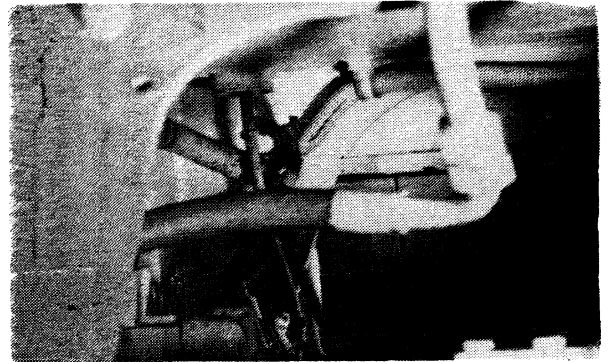

Study SAFETY RULES in the front of this manual thoroughly for the protection of machine and safety of personnel.

LINKAGE

6.4.7 BUCKET CYLINDER LINKAGE

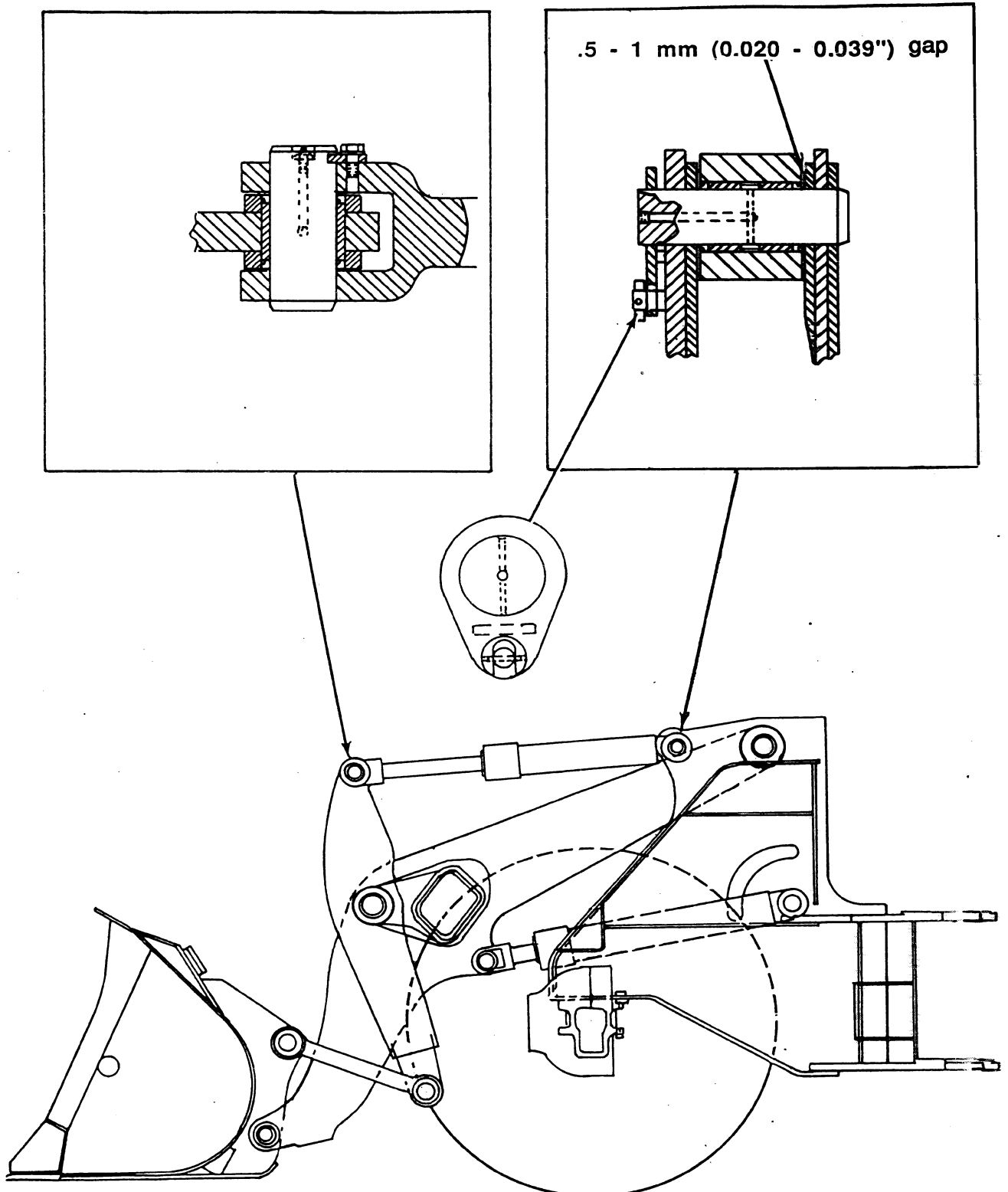

Study SAFETY RULES in the front of this manual thoroughly for the protection of machine and safety of personnel.

STARTER MOTOR - BOSCH KB 24V

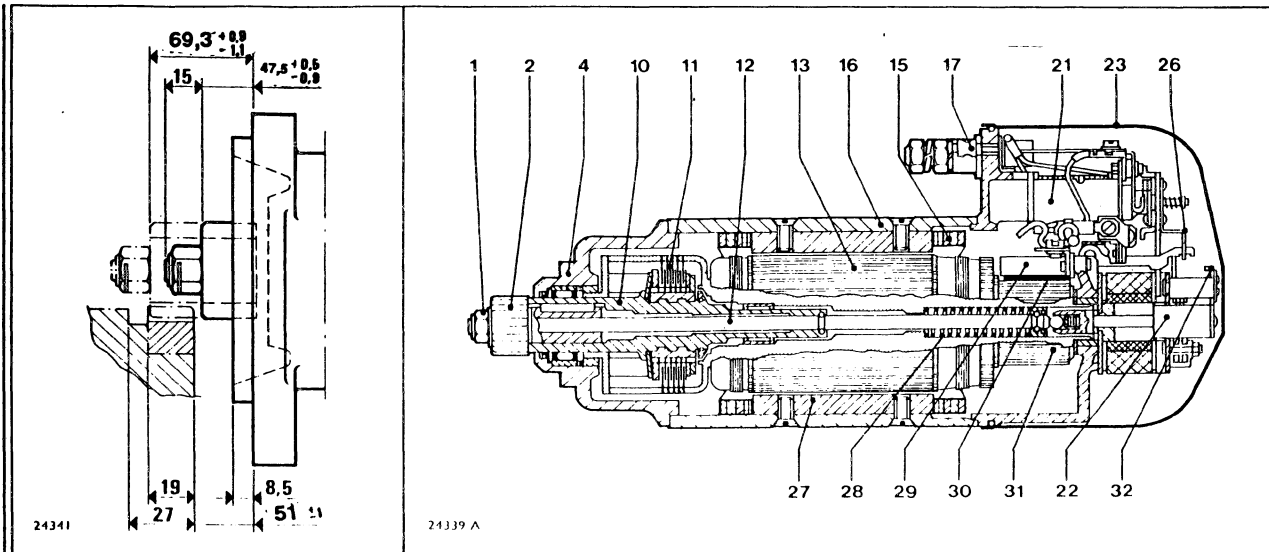

CLEARANCE DATA

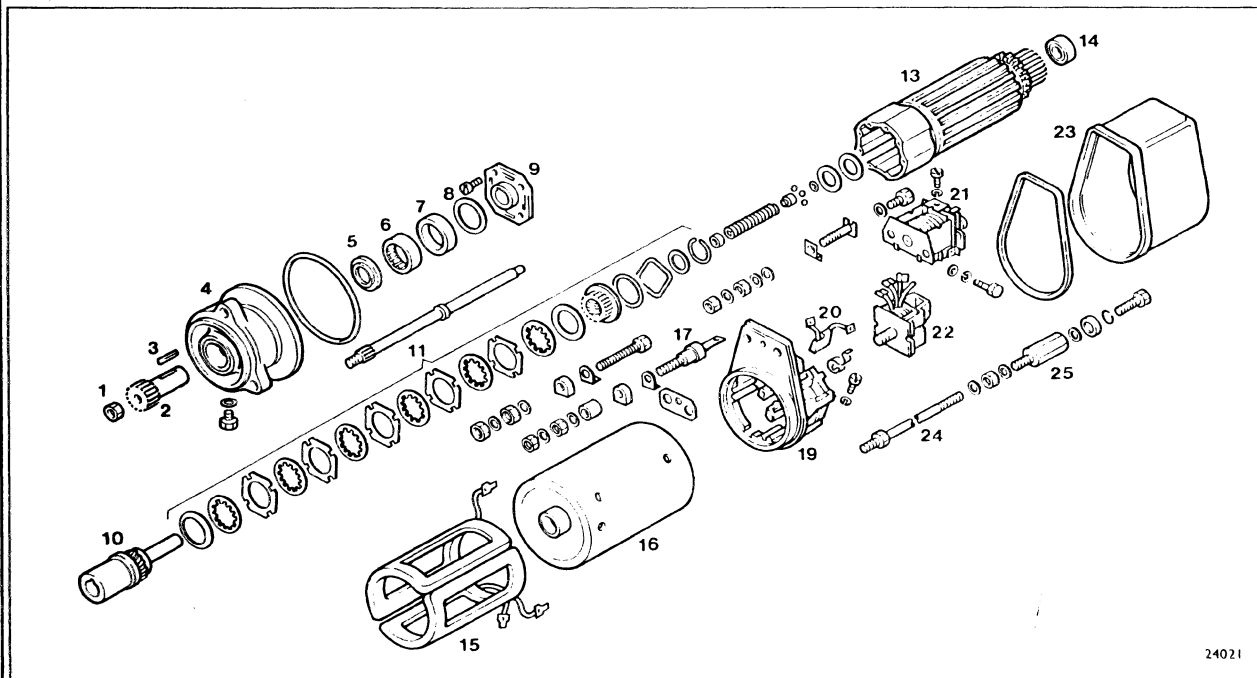

THREEQUARTER VIEW - DISASSEMBLED STARTER

- | | |
|------------------------|------------------------------|
| 1. Drive pinion nut | 17. Terminal |
| 2. Drive pinion | 18. Seal |
| 3. Woodruff key | 19. Commutator end head |
| 4. Drive end head | 20. Brush |
| 5. Seal | 21. Control relay |
| 6. Roller bearing | 22. Engagement relay |
| 7. Bushing | 23. Cover |
| 8. Ring washer | 24. Thru bolt |
| 9. Flange | 25. Spacer |
| 10. Sleeve | 26. Backing plate |
| 11. Multi-plate clutch | 27. Pole shoes |
| 12. Engagement plunger | 28. Reaction spring |
| 13. Armature | 29. Brush holder |
| 14. Roller bearing | 30. Brush |
| 15. Windings | 31. Commutator |
| 16. Carcass (frame) | 32. Drive unit release lever |

Study SAFETY RULES in the front of this manual thoroughly for the protection of machine and safety of personnel

STARTER MOTOR
Pictorial operation sequence

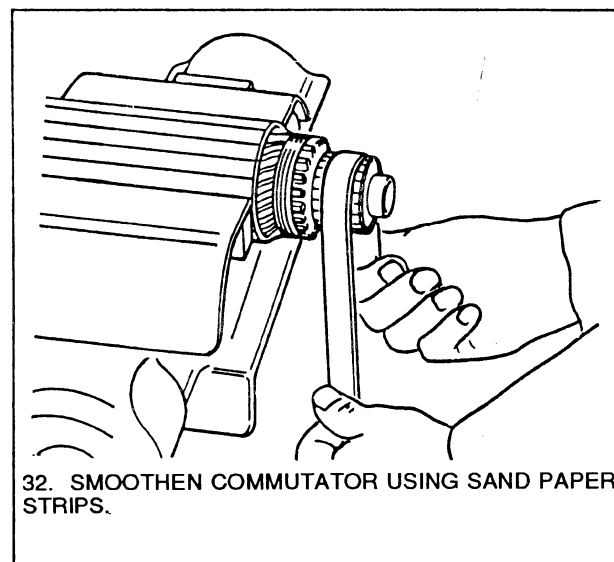
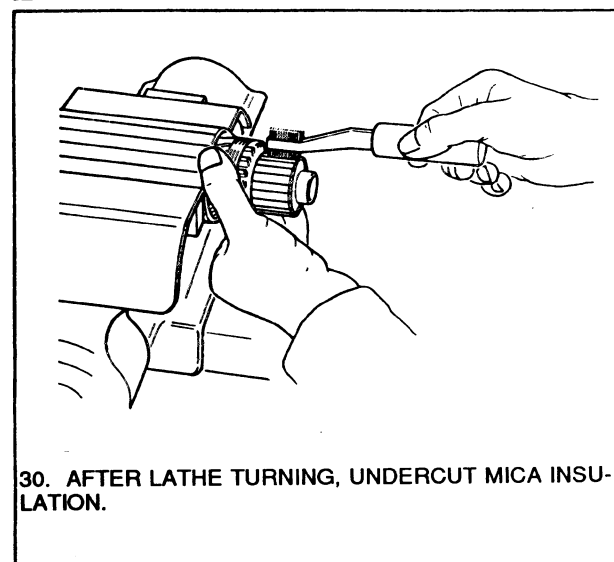
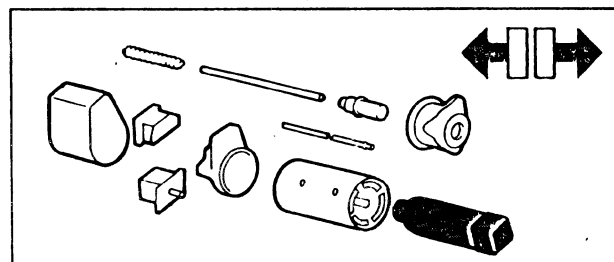
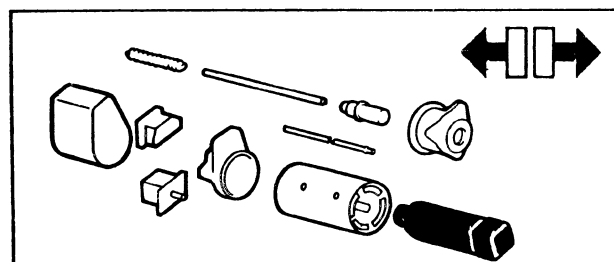
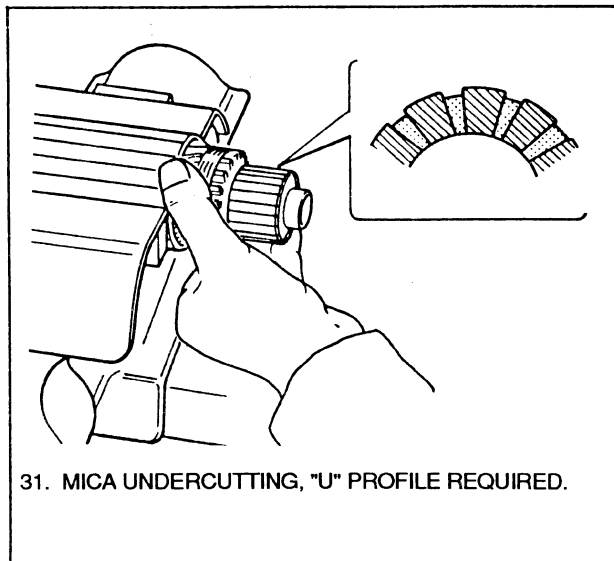
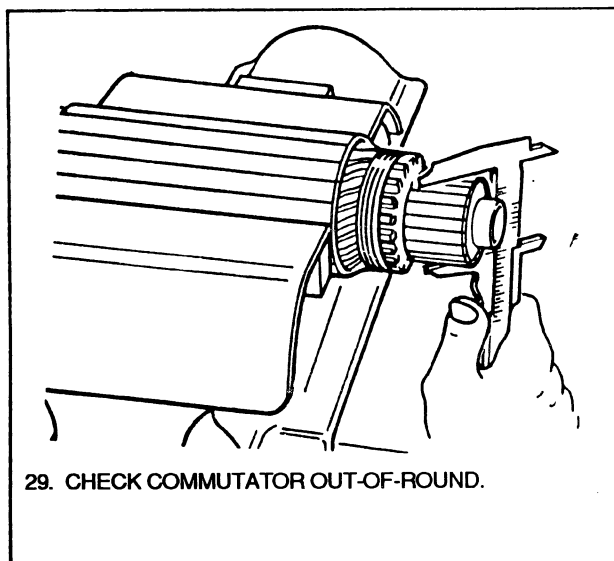
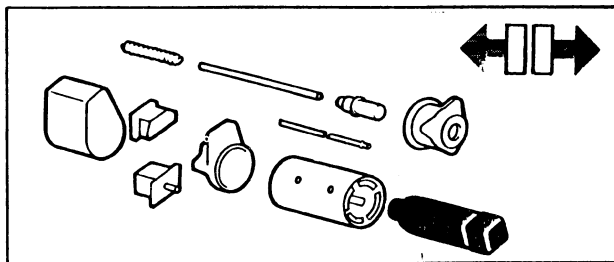
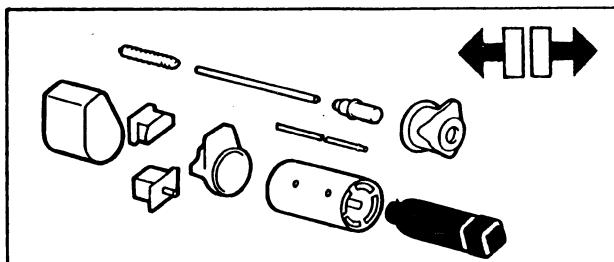

Study **SAFETY RULES** in the front of this manual thoroughly for the protection of machine and safety of personnel

7 - ENGINE STARTING KEY SWITCH

Wire

- 724 Position 30 to junction box 147
- 869 Position 19 to electromagnet engine shutoff solenoid 12
- 870 Position 50 to push button switch, cold weather starting 10
- 390 Position 58 to relay DIODE 24
- 804 Position 15/54 to service relay 14

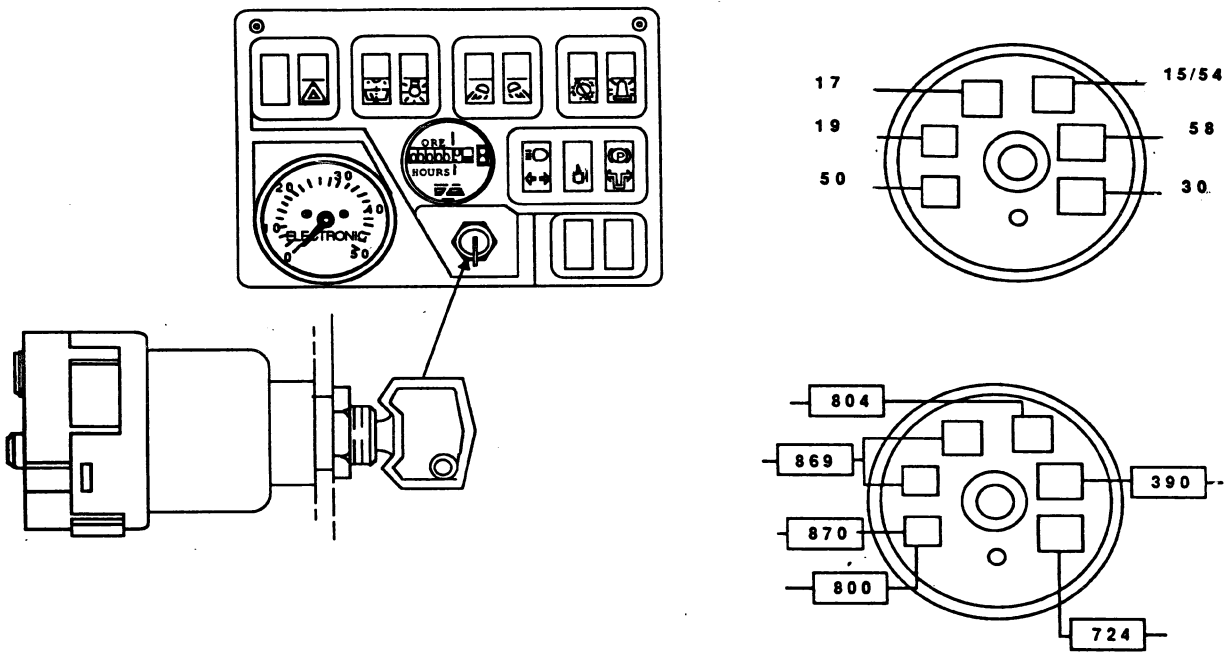

Location: Right hand front dash instrument panel

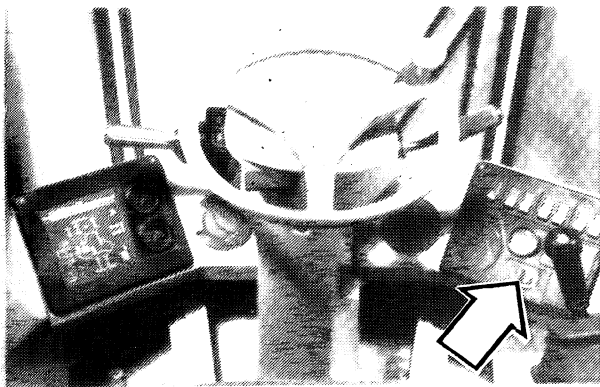

Study SAFETY RULES in the front of this manual thoroughly for the protection of machine and safety of personnel

56 - WIPER MOTOR, REAR

WIRE

- 877 Position 53a to rear wiper motor & washer switch 55
- 813 Position 53 to rear wiper motor & washer switch 55
- 823 Position 31b to rear wiper motor & washer switch 55
- 000 Position 31 to frame ground

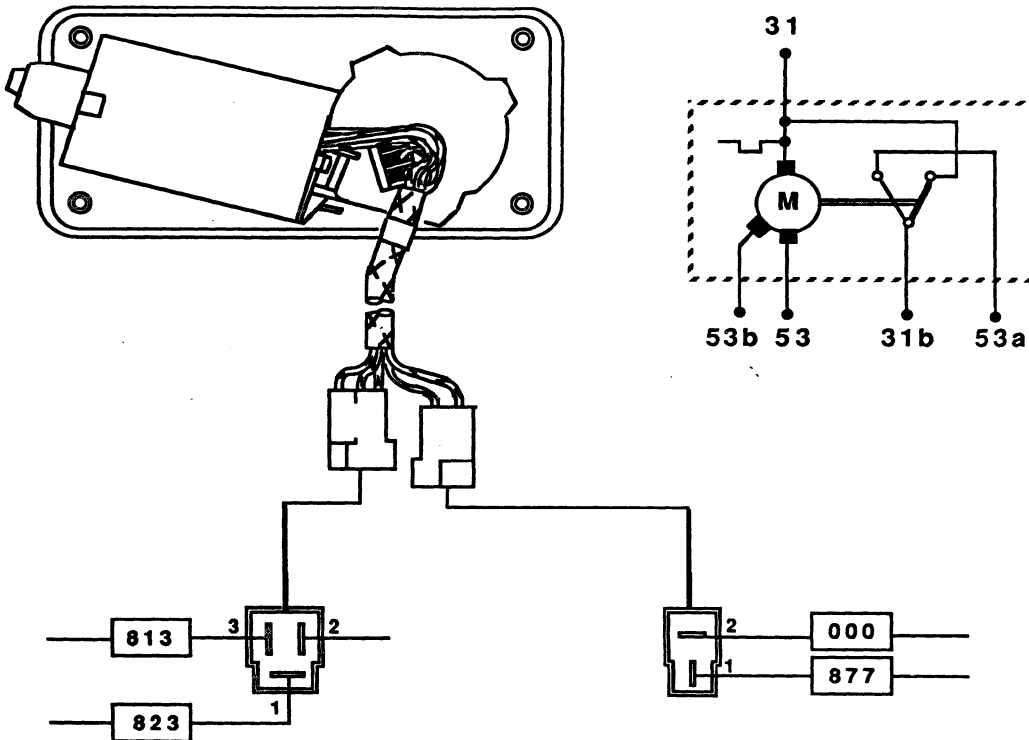

Location: Inside rear of cab, right side, below window, under console cover

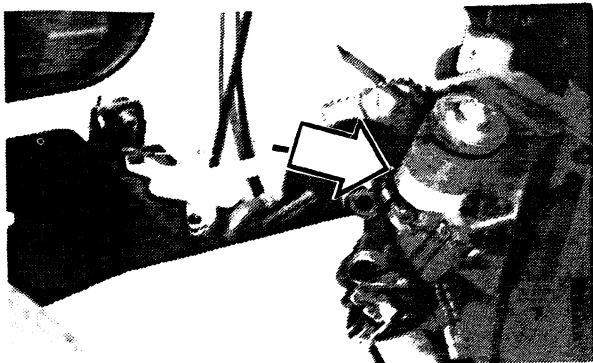

Study SAFETY RULES in the front of this manual thoroughly for the protection of machine and safety of personnel

continued : Alternator

Test of alternator BOSCH type N1

Remove alternator from the engine and test with appropriate instrumentation and test bench.

SPECIFICATIONS

Rotation :	clockwise
Current output at 6000 RPM :	≥ 55 A
Max continuous speed :	11,000 RPM
Brush wear limit :	7 mm
Rated voltage :	28 V
Rectifier diode resistance at 25° C :	$8 \pm 10 \Omega$
Indirect resistance :	infinite

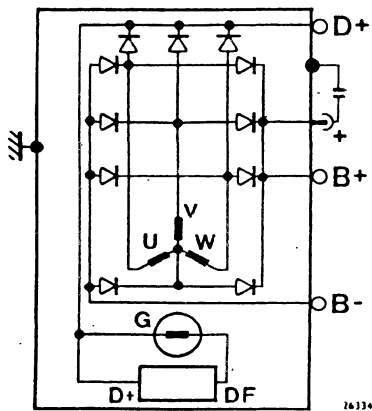

Electrical schematic diagram.

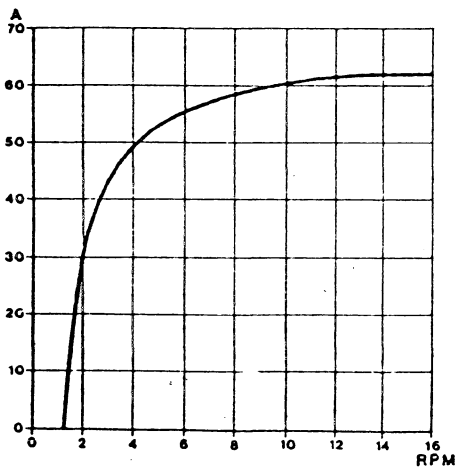

Current output curve.

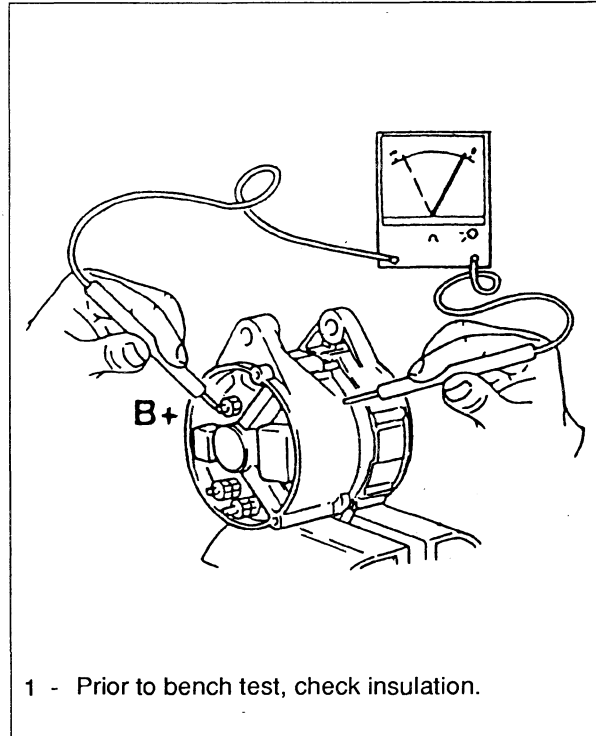

1 - Prior to bench test, check insulation.

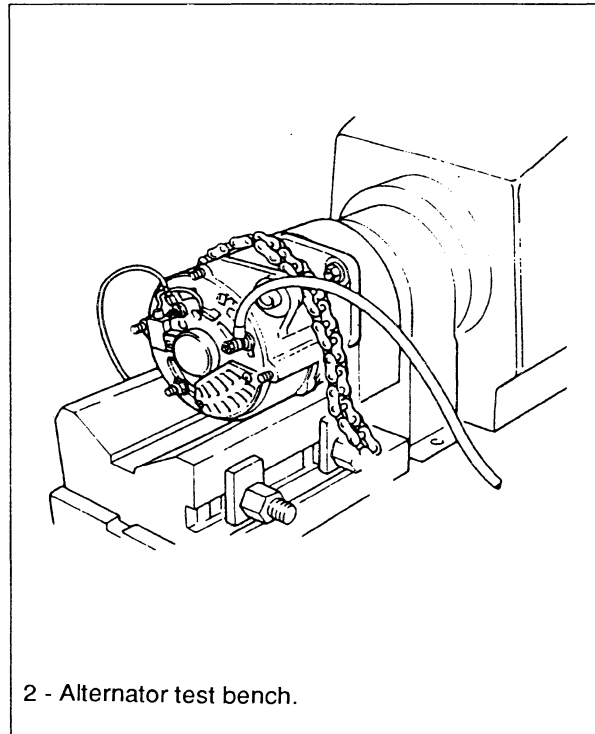

2 - Alternator test bench.

Study SAFETY RULES in the front of this manual thoroughly for the protection of machine and safety of personnel

continued : Alternator

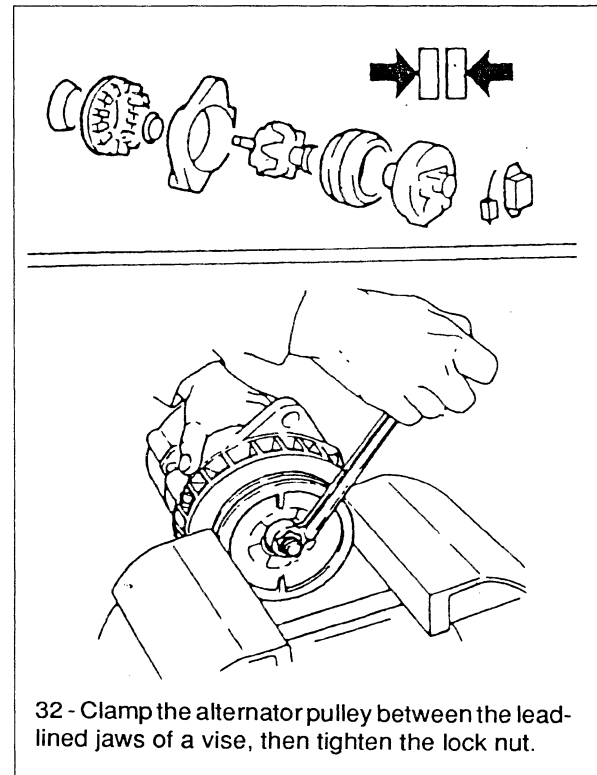
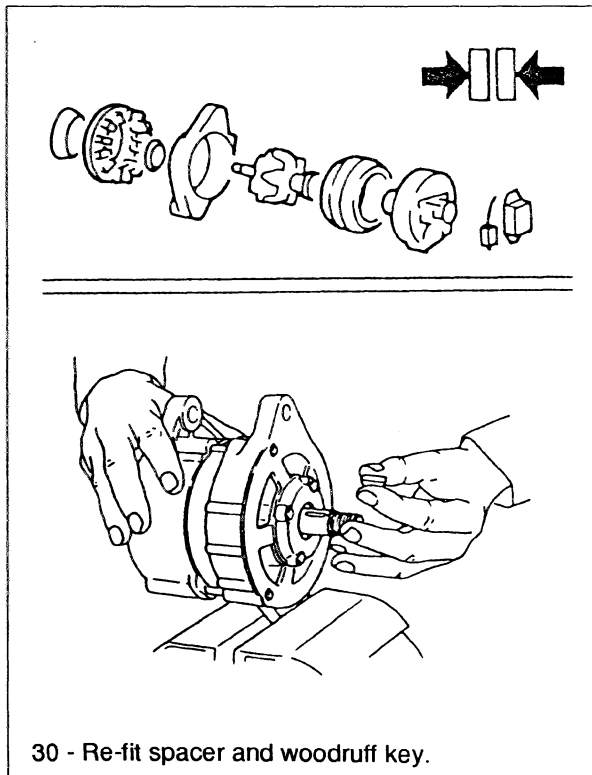
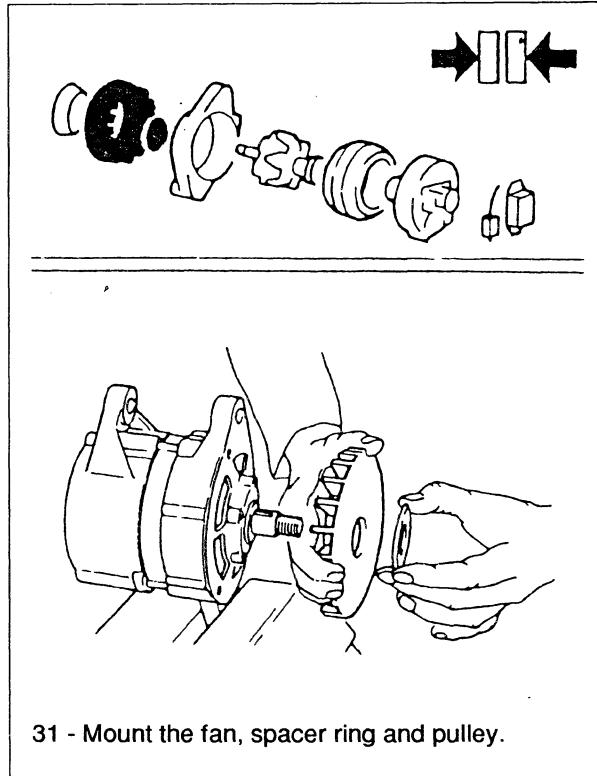
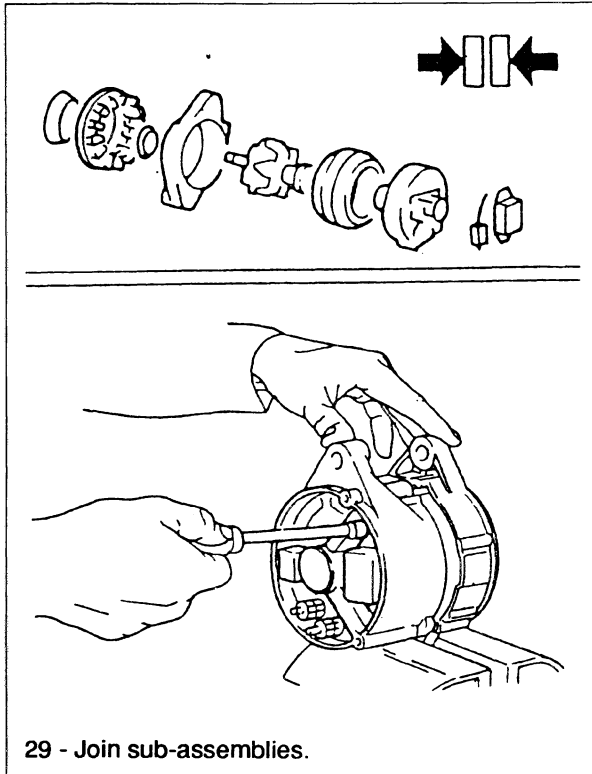

Study SAFETY RULES in the front of this manual thoroughly for the protection of machine and safety of personnel

8.3 REPAIR PROCEDURES

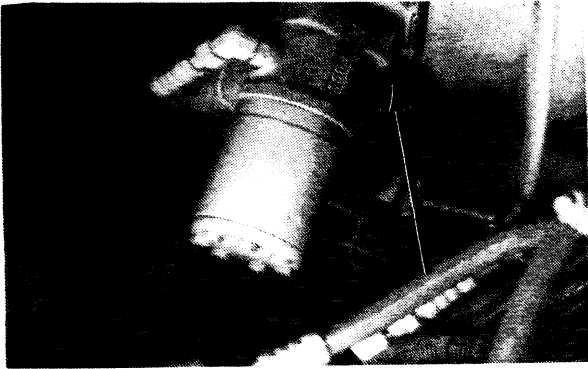

8.3.1.17

Remove three capscrews holding the steering control valve to the cab floor plate. There is no need to disconnect hoses on the valve.

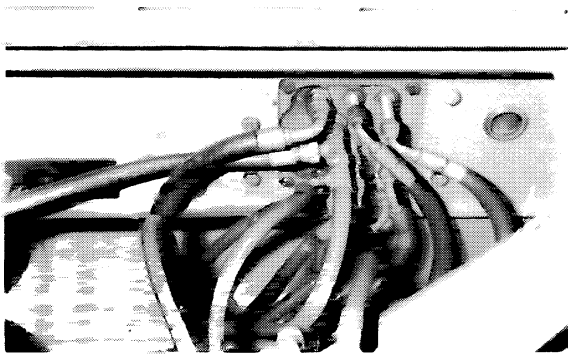

8.3.1.18

Disconnect hydraulic manipulator's hoses at right side of cab.

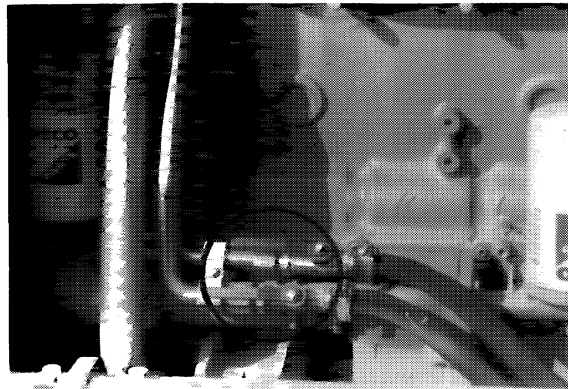

8.3.1.19

Shut off valves supplying fluid to heater.



8.3.1.20

Disconnect two heater hoses located at right rear of cab.

Study **SAFETY RULES** in the front of this manual thoroughly for the protection of machine and safety of personnel.

8.3 REPAIR PROCEDURES



8.3.3.6 HEATER and BLOWER FAN

8.3.3.6.1 Heater Removal

8.3.3.6.1.1

Remove roll pin, on hydraulic controls lock lever, and remove lever. Also remove four screws securing heater control to panel.

Γ-94700

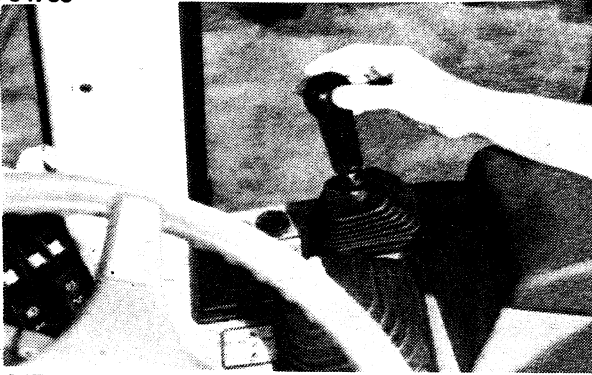

8.3.3.6.1.2

Remove handles and lock nuts from hydraulic control levers.

Γ-94703

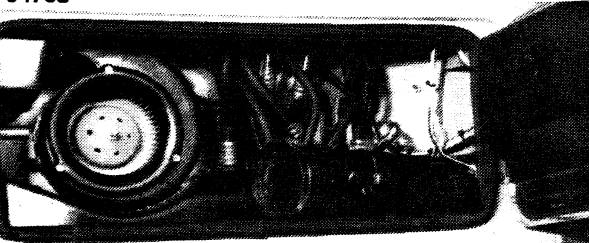

8.3.3.6.1.3

Disconnect and tag wiring to the cigarette lighter. Also disconnect flex hose from heater.

Γ-94695



8.3.3.6.1.4

Remove screws and nuts attaching right side console panel and remove panel.

Study **SAFETY RULES** in the front of this manual thoroughly for the protection of machine and safety of personnel.

CLICK HERE TO **DOWNLOAD** THE COMPLETE MANUAL

- Thank you very much for reading the preview of the manual.
- You can download the complete manual from: www.heydownloads.com by clicking the link below



- Please note: If there is no response to CLICKING the link, please download this PDF first and then click on it.

CLICK HERE TO **DOWNLOAD** THE COMPLETE MANUAL