

**DAIHATSU
TYPE EJ ENGINE**

**Service
manual**

Revision 1 : October 1998

DAIHATSU MOTOR CO., LTD.

NO.9726

CLICK HERE TO **DOWNLOAD** THE COMPLETE MANUAL

- Thank you very much for reading the preview of the manual.
- You can download the complete manual from: www.heydownloads.com by clicking the link below



- Please note: If there is no response to CLICKING the link, please download this PDF first and then click on it.

CLICK HERE TO **DOWNLOAD** THE COMPLETE MANUAL

1.4.2 Diagnosis through inquiries

The diagnosis through inquiries is to collect information from the customer before confirming the malfunction phenomena. The diagnosis through inquiries proves to be very important clues in reproducing malfunction phenomena.

Since the information obtained by the diagnosis through inquiries is referred to during the trouble shooting, it is imperative to make an inquiry of the customer, centering on the items related to the malfunction, instead of simply carrying out the diagnosis through inquiries.

LEF00016-00000

1.4.3 Confirmation, record and erasure of diagnosis code

When the diagnosis abnormality code is indicated, confirm whether the malfunction took place in the system or is taking place now. Also it is necessary to check any relation between the code and the reproduced malfunction. For this purpose, the diagnosis code should be indicated twice; in other words before and after the confirmation of the phenomena.

LEF00017-00000

1.4.4 Confirmation of reproduction of malfunction phenomena

In carrying out the trouble shooting, it is imperative to reproduce the malfunction phenomena by creating conditions and environments similar to the situation where the malfunction took place, based on the information obtained by the diagnosis through inquiries. As for the phenomenon that is hard to be reproduced, it is most important to try to reproduce it patiently by applying external factors, such as vibration (moving wire harnesses or relays by hand), heat (applying hot wind) and water (giving humidity).

Moreover, if you presume sections (parts) which may have caused the malfunction, connect a tester, etc. to them and check to see if the malfunction takes place, you can evaluate whether the sections (parts) are functioning properly or not, too.

LEF00018-00000

1.4.5 Basic check

A. Hints for basic check

1. In most cases, engine troubles are attributable to systems other than the EFI system.
 - (1) Battery voltage, fuse blown or fusible link blown.
 - (2) Body earth.
 - (3) Fuel leakage, fuel filter clogged or fuel pump malfunctioning.
 - (4) Spark plugs faulty, ignition coil faulty, or ignition timing adjusted improperly.
 - (5) Admission of air.

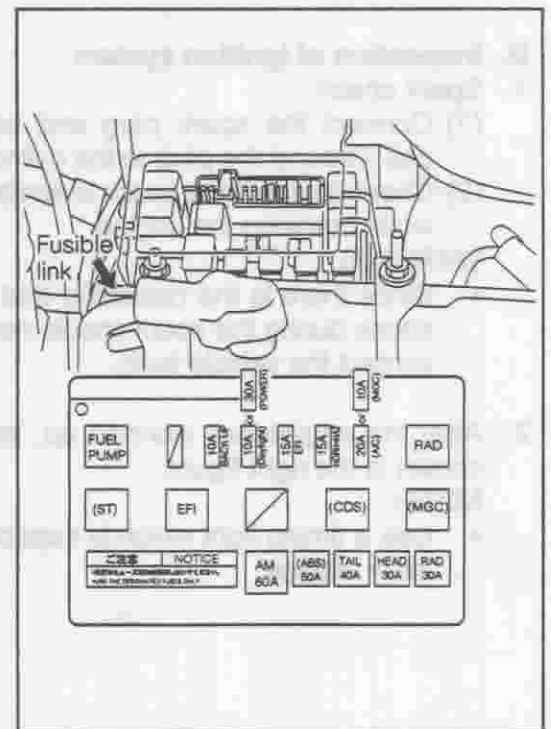

LEF00019-00014

5.6 DIAGNOSIS CODE NO. 24
VARIABLE RESISTER SENSOR & CIRCUIT

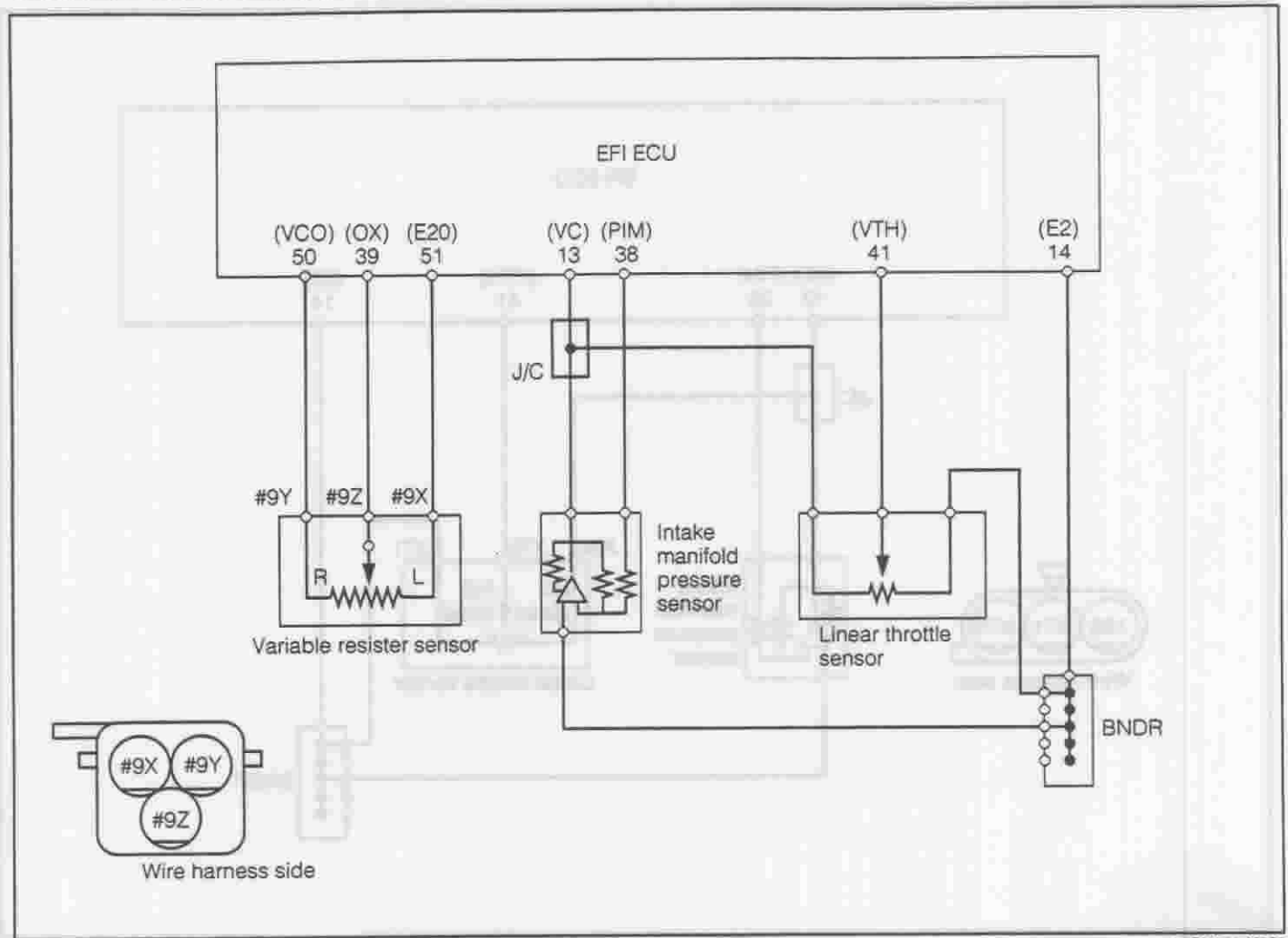

LEF00092-00079

When the signal from the variable resistor sensor is 4.8 V or more or less than 0.2 V continuously for more than a certain length of time:

1. Check to see if the connector is connected properly.
2. Turn off the ignition switch.

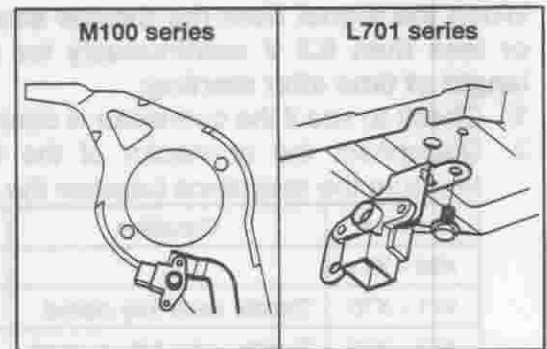

LEF00093-00080

3. Check wire harness.
 - (1) Connect the SST between the ECU connectors and the wire harness connectors.
 - (2) Ensure that the voltage between the SST terminals 39 and 51 is within the specified value when the ignition switch is turned to the ON position.
Specified Value: 0.2 V or more, but less than 4.8 V

NOTE:

- If the measured voltage does not conform to the specifications, check the wire harness.

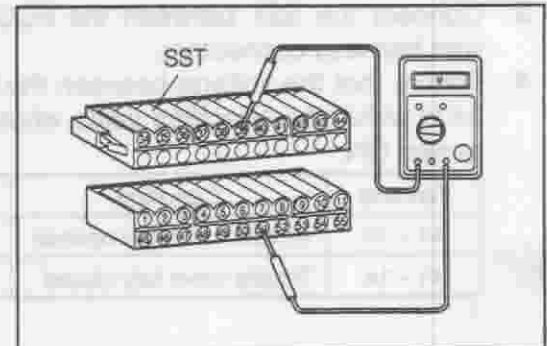

LEF00094-00081

TYING BELT

COMPONENTS

(Refer to the "COMPONENTS" section.)

REMOVAL

EM

- 1. Remove the V-belt from the engine.
- 2. Remove the V-belt from the engine.

- 3. Remove the V-belt from the engine.
- 4. Remove the V-belt from the engine.

INSTALLATION

- 1. When the V-belt is installed, it should be tight.

ENGINE MECHANICAL



- 1. Remove the timing belt cover.
- 2. Remove the timing belt cover.

CAUTION

- 1. Perform the engine timing operation in the correct order.

NOTE

- 1. Before the timing cover is removed, the timing belt should be loosened with the timing cover removed.
- 2. When the timing cover is removed, the timing belt should be loosened with the timing cover removed.

10. Remove the spark plug from the cylinder head.

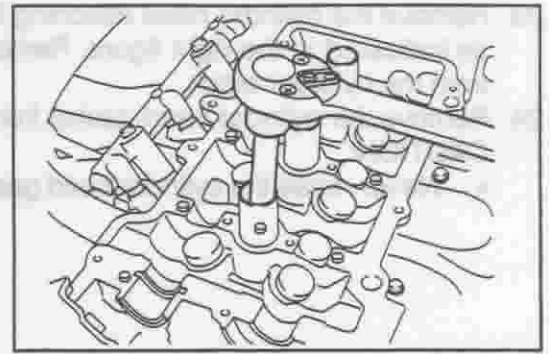

LEM00033-00032

11. Remove the intake manifold from the cylinder head.
 12. Remove the intake manifold gasket from the cylinder head.

CAUTION:

- Never reuse the removed intake manifold gasket.

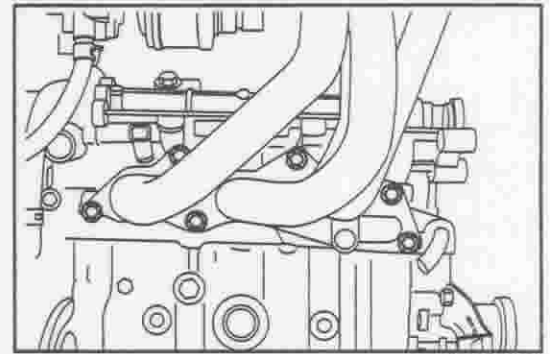

LEM00226-00224

13. Remove the fuel delivery pipe from the cylinder head.
 14. Remove the injector from the cylinder head.

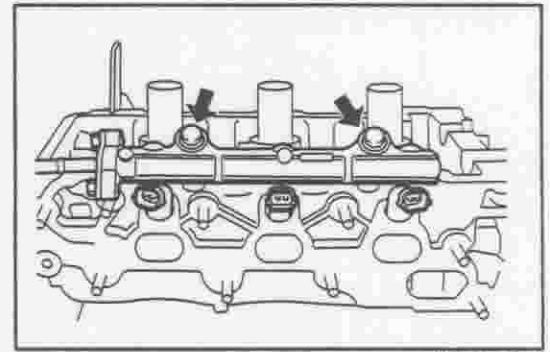

LEM00035-00034

15. Remove the O₂ sensor harness from the clamp.
 16. Remove the exhaust manifold heat insulator from the exhaust manifold.
 17. Remove the exhaust manifold from the cylinder head.
 18. Remove the exhaust manifold gasket from the cylinder head.

CAUTION:

- Never reuse the removed exhaust manifold gasket.

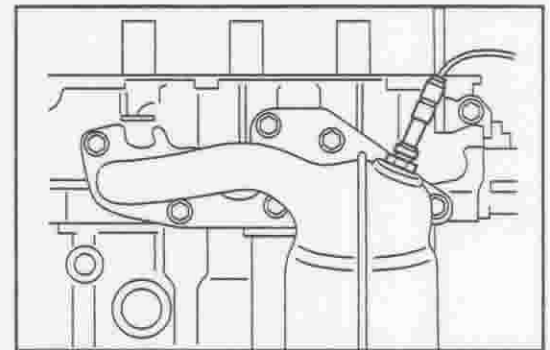

LEM00036-00035

19. Remove the water inlet from the cylinder head.
 20. Remove the thermostat from the cylinder head.
 21. Remove the water temperature switch.
 22. Remove the cam position sensor from the cylinder head.

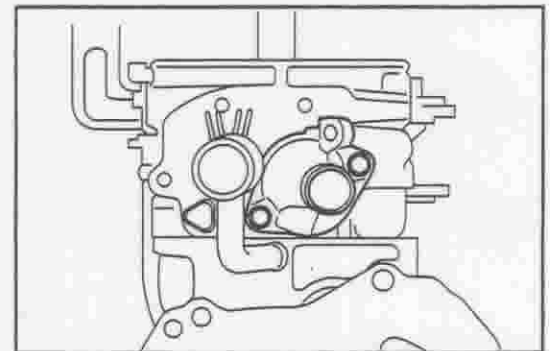

LEM00037-00036

INSTALLATION

1. Clean the cylinder block upper gasket surface. Install the cylinder head gasket, while aligning it with the pin ring for locating use.
2. Temporarily install the crankshaft pulley bolt to the crankshaft.
3. Turn the crankshaft so that the crankshaft key groove may come at the top position.
4. Install the cylinder head to the cylinder block.

NOTE:

- Care must be exercised to ensure that no damage is made to the gasket surface of the cylinder head with the cylinder block.

5. Coat each cylinder head bolt with a thin film of engine oil. Using these bolts, install the cylinder head to the cylinder block. Tighten the bolts evenly over two or three stages, following the sequence shown in the right figure.

Tightening Torque: 54.0 ± 5.0 N·m

NOTE:

- Failure to tighten the bolts evenly may cause cracks and distortion of the cylinder head, even leading to engine seizure.
- Make sure that all the bolts are tightened uniformly to a constant level as well as that they are tightened within the specified torque.

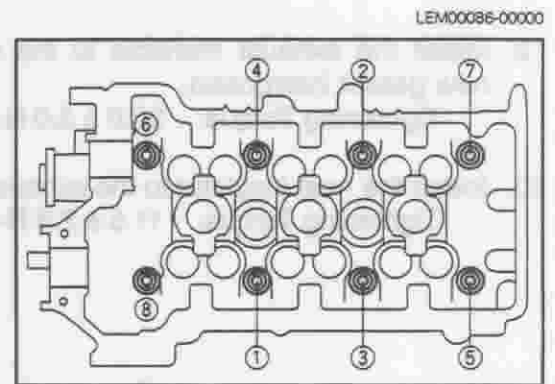

6. Installation of water inlet
 - (1) Install the thermostat to the water inlet, as shown in the illustration.
 - (2) Apply soap water to the outer periphery of the thermostat grommet.
 - (3) Install the water inlet to the cylinder head.

Tightening Torque: 19.0 ± 3.8 N·m

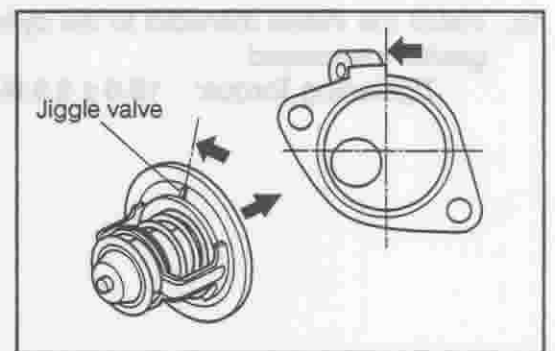

7. Clean the threaded portion of the water temperature sensor. Wind seal tape around the threaded portion. Tighten the sensor to the cylinder head, using a long box wrench.

Tightening Torque: 24.0 ± 4.8 N·m

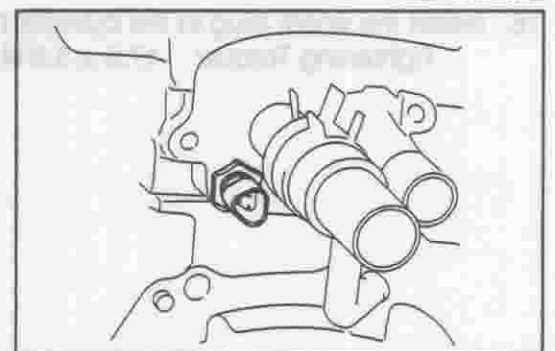

- (1) Insert a compression gauge into the spark plug hole.
- (2) Depress the accelerator pedal fully.
- (3) While cranking the engine, measure the compression pressure.

Compression Pressure:

1579 - 1755 kPa at 400 rpm

Difference Between Cylinders:

147 kPa at 400 rpm

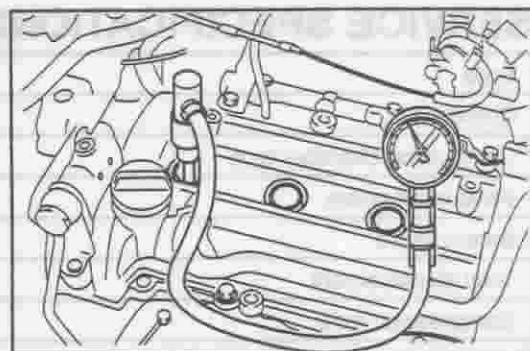

LEM00213-00200

- (4) Repeat the step (1) through (3) for each cylinder.
- (5) If the compression of one or more cylinders is low, pour a small amount of engine oil into that cylinder through the spark plug hole and repeat the steps (1) through (3) for the cylinder with low compression.
 - If adding oil helps the compression to improve, chances are that the piston rings and/or cylinder bores are worn or damaged.
 - If the pressure remains low after the operation described in the step (5) has been performed, the valve may be sticking or seated improperly, or there may be leakage past the gasket.

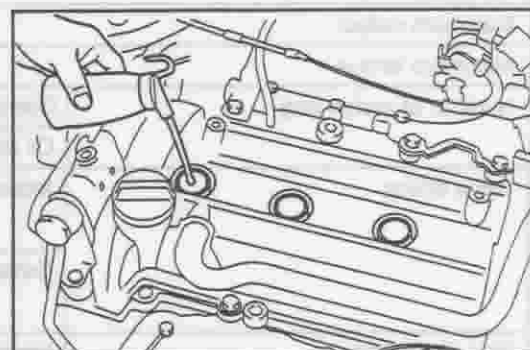

LEM00214-00201

6. Install the spark plug to the cylinder head, (Refer to the IG section.)
7. Install the fuel pump relay to the relay box.

GENERAL SERVICE INSTRUCTION

1. Use fender covers, seat covers and floor sheets so that the vehicle may not get dirty or be scratched.
2. Jacking up
 - (1) When only the front section or rear section of the vehicle is jacked up, be sure to place chocks at the wheels so as to insure safe operations.
 - (2) When the vehicle has been jacked up, be sure to support the vehicle at the specified section using the safety stands. (Refer to the relevant Chassis section in the manual for the vehicle concerned.)
3. Handling instructions related to battery.
 - (1) Before you start performing the electrical works, make certain to disconnect the battery ground cable terminal from the negative (-) terminal of the battery.

NOTE:

 - Before disconnecting the battery ground cable terminal from the negative (-) terminal of the battery, be sure to read out the diagnosis code of the EFI system if it is equipped.
 - After reconnecting the battery ground cable terminal to the negative terminal of the battery, be sure to reset the watch or radio, if the vehicle is equipped with such equipment.
 - (2) When it becomes necessary to disconnect the battery power supply for the purpose of carrying out checks or repairs, always disconnect the negative (-) terminal of the battery ground cable from the negative terminal of the battery first.
 - (3) To avoid damaging battery plates, after the terminal nut has been loosened, pull out the battery ground cable terminal straight upward, rather than turning or prying the terminal.

NOTE:

 - Be sure to employ a battery terminal puller (commercially available) to remove the battery ground cable terminal from the negative terminal of the battery, if any difficulty is encountered.
 - (4) Clean the battery terminal posts or battery ground terminals, using a cloth. Never use a file or other adhesive agents.
 - (5) When connecting the battery ground cable terminal to the battery, first the battery ground cable terminal should be fitted onto the battery post with the attaching nut in a loose state. Then, tighten the nut. Never tap the terminal onto the battery post, using a hammer, a spanner wrench or the like.
 - (6) As for the cover at the positive (+) terminal side, be sure to install it at the correct position.
4. Repairing of fuel system
 - (1) The EFI-equipped vehicles employ a high fuel pressure. Therefore, the following notes should be observed.
 - ① Be sure to prevent the fuel from splashing with a cloth or the like, when the union bolt or other connected section of the fuel line is loosened or slackened.
 - (2) When connecting/disconnecting the fuel line.
 - ① Tighten each connecting section to the specified torque.
 - ② Attach new specified clips to each connecting section.
 - ③ Be certain to place a suitable container, a cloth, etc. under the connected section of the fuel line before disconnecting the fuel line.
 - ④ Before the fuel line is disconnected, be sure to release the inner pressure of the fuel tank by detaching the fuel filler cap.
 - (3) Do not work near open flames.
5. For increased work efficiency and improved accuracy, be sure to utilize the SSTs (Special Service Tools) effectively.

CLICK HERE TO **DOWNLOAD** THE COMPLETE MANUAL

- Thank you very much for reading the preview of the manual.
- You can download the complete manual from: www.heydownloads.com by clicking the link below



- Please note: If there is no response to CLICKING the link, please download this PDF first and then click on it.

CLICK HERE TO **DOWNLOAD** THE COMPLETE MANUAL