

**CROWN**

SX

# Service Manual



**SX3000** Series

CLICK HERE TO **DOWNLOAD** THE COMPLETE MANUAL

- Thank you very much for reading the preview of the manual.
- You can download the complete manual from: [www.heydownloads.com](http://www.heydownloads.com) by clicking the link below



- Please note: If there is no response to CLICKING the link, please download this PDF first and then click on it.

CLICK HERE TO **DOWNLOAD** THE COMPLETE MANUAL

<b>M6 – DIRECTION</b>	<b>PAGE</b>	<b>SER-N0. CUT</b>	<b>REV.</b>
<b>Live ring bearing</b> .....	<b>121</b>		
Disassembly .....	121		
Assembly .....	121		
<b>M6 – DIRECTION</b>	<b>PAGE</b>	<b>SER-N0. CUT</b>	<b>REV.</b>
<b>Control handle return springs</b> .....	<b>122</b>		
Adjustment .....	122		
Disassembly .....	122		
Assembly .....	122		
<b>Control Handle Grip</b> .....	<b>123</b>		
Main Components .....	123		
<b>Hand grip component removal and assembly</b> .....	<b>124</b>		
Hand Grip Shells .....	124		
Upper and lower shell removal .....	124		
Upper and lower shell assembly .....	125		
Switch Unit .....	126		
Disassembly .....	126		
Switch unit assembly .....	126		
“Rabbit/Turtle” toggle switch .....	127		
Disassembly .....	127		
Assembly .....	127		
Hydraulic PC board .....	127		
Disassembly .....	127		
Assembly .....	127		
Main PC Board Removal/Installation .....	128		
Potentiometer .....	129		
.....	129		
Disassembly .....	129		
Assembly .....	130		
.....	130		
Safety Reverse Switch .....	130		
Disassembly .....	130		
Assembly .....	130		
Horn switch .....	131		
Disassembly .....	131		
Assembly .....	132		
Hand Grip .....	132		
Disassembly .....	132		
Assembly .....	132		
<b>M7 – MAST</b>	<b>PAGE</b>	<b>SER-N0. CUT</b>	<b>REV.</b>
<b>Mast</b> .....	<b>135</b>		
General .....	135		
Torque Requirements .....	135		
Lifting Gear Minimum Capacity .....	135		
TL Mast .....	135		
TT Mast .....	135		
Mast Removal .....	135		
Installation .....	136		
Fork Carriage Removal .....	136		
Fork Carriage Installation .....	137		
Fork Carriage Adjustment .....	137		
Mast Maintenance .....	138		
Lubricating Roller Tracks .....	138		
Mast shims .....	139		
TL Mast Assembly .....	140		
TT Mast Assembly .....	141		

**General**

The present manual is designed for Customer Service engineers who wish to familiarise themselves with the maintenance work required for the various truck components.

It also contains troubleshooting sections which can be used to identify and remedy truck faults.

**INFORMATION**



*This book is not an operating manual. It is designed solely for specialist personnel who have been trained and authorised to carry out the work described in the manual.*

This manual therefore contains fewer and less detailed warnings than the Operator's Manual, as the latter is aimed at persons who have very little or no prior experience at all.

**Operating Instructions**

This manual contains no operating instructions. An operating instructions manual is supplied with the vehicle. Additional copies can be ordered as required.

With the help of this manual you and your personnel will be able to ensure the long service life, operational safety and error free functioning of your CROWN vehicle.

**Service Training**

CROWN offers the appropriate vehicle related training for service personnel. Details on this training can be obtained from CROWN on request.

**Ordering Spare Parts**

The maintenance manual does not cover spare parts. These are listed in a separate manual.

Spare parts can be ordered by quoting:

- The truck specification number
- The truck model number
- The truck serial number

This information can be found on the truck's data plate. Only if this information is provided can the order be processed quickly, correctly and reliably.

Please refer to the Technical Specifications Sheet for the utilisable loads, technical data and dimensions for this series. Brochures can be obtained from your CROWN dealer or from the following address:

**CROWN Gabelstapler GmbH & Co.KG**  
**Moosacher Str. 52**  
**80809 Munich**  
**GERMANY**  
**Tel.: +49 (0)89 / 93 002 -0**  
**Fax: +49 (0)89 / 93 002 -175 or133**

**Using the Manual**

The manual is divided into sections. The following table shows how the manual is structured.







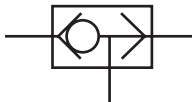

Section	Description
IDX	Table of Content
MA	Safety
ITD	Introduction
M1	Lubrication and Adjustment
M2	Hydraulics
M3	Drive Unit
M4	Electrical
M5	Brake
M6	Steering
M7	Mast / Lifting Mechanism
M8	Cylinder
DIA	Electrical Diagrams
HYD	Hydraulic Schematic

A01M-gb

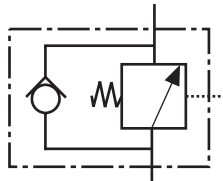
Page intentionally blank

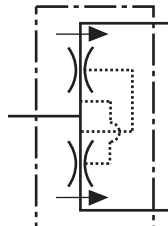
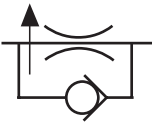
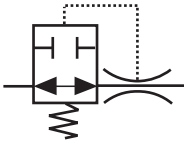
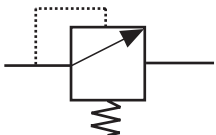
I-18	Wiring / Switches	Check all line connections are secure			x	
I-19		Clean truck, battery and charger connector contacts and check contact springs.		x		
I-20		Check mast cable connectors are secure, strain relief present? Check and adjust cable pre-tension		x		
I-21		Visually inspect the charger connection lead	x			
I-22		Check wiring, switches & connections are secure, check insulation for damage.			x	
I-23		Check line connections to traction controller, EMERGENCY DISCONNECT switch and main fuses FU1 & 2 are secure			x	
I-24		Check power cables from drive and lift motors for damage			x	
I-25		Check battery cables and connectors for damage			x	
I-26	Battery	Check / service battery as required in accordance with battery manufacturer's service manual.	x			
I-27		Check battery condition			x	
I-28		Check acid density and acid level			x	
I-29	Contactors	Clean and check main contactor tips, replace if necessary.			x	
I-30		Clean and check pump contactor tips, replace if necessary.		x		
I-31	Traction controller	Check operation. Read the error log	x			
I-32		Ensure it is securely fixed				x
I-33	Brake	Blast off abrasion with pressurised air; check conical nipple for damage; check air gap.	x			
I-34		Check brake lining and friction surfaces for wear, replace parts as required.			x	
I-35		Check air gap and brake lining wear on the motor brake; clean brake linings (apply dry compressed air), and replace if necessary				x
I-36	Control Handle	Test return spring operation.			x	

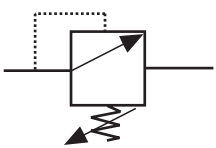
L04\_2-GB

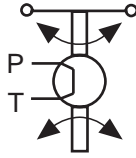
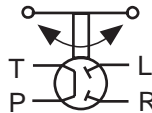
	Throttle, fixed		Shuttle valve
	Throttle, adjustable		Single counterbalance valve assembly in manifold
	Pressure-compensated flow control, fixed		Flow divider/combiner
	Pressure-compensated flow control with reverse flow bypass; fixed.		Velocity fuse
	Relief valve, fixed setting		Bypass flow control with controlled flow, pressure-regulated
	Relief valve, adjustable		Shut-off valve, manual
	Check valve		Torque generator
			Hydraulic steer unit

M3561

## Replacing the relief valve

- Remove the locking mechanism (see Fig.) and unscrew the relief valve (3),
- Remove the O ring and the strainer from the valve seat if they are still in there.
- Apply a thin coat of hydraulic oil to the new O ring and place it in the valve seat with the strainer.
- Apply hydraulic oil to the relief valve, insert it into the valve seat and tighten. Tap in the new locking mechanism.
- Refit the hydraulic unit and adjust the relief valve.

## Relief valve setting

The relief valve protects the hydraulic system and the lifting mechanism from overloading.

**WARNING**



***Do not let the pump unit run unless it is fixed to the chassis.***

***The amount of torque will twist the unit. This can result in short circuits and damage.***

SX3000	1,350 kg	1,350 kg	1,450 kg
--------	----------	----------	----------

H01-GB

## Relief valve test and setting

- With the truck at operating temperature, raise a test load on the forks that corresponds to 110% of rated capacity (= minimum load). It should be easy to raise the load.
- Now raise a test load that corresponds to 110% of rated capacity + 100 kg (=maximum load). It should not be possible to raise this load. (relief valve opens).

If necessary, adjust the relief valve so that it opens within the above mentioned tolerance range.

- Hold onto the setscrew and loosen the jam nut (see Fig.).
- Turn the setscrew clockwise to increase the threshold? until the valve opens, turn it anti-clockwise to reduce the threshold.
- Counter-fix the setscrew again with the nut.

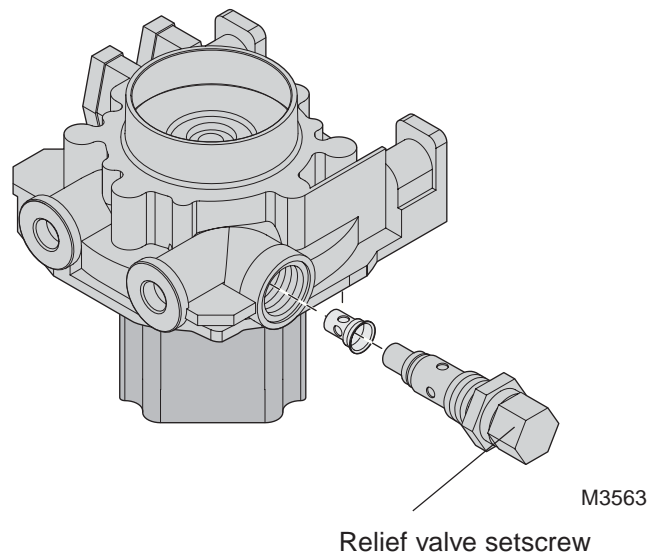

## Gear unit disassembly

### NOTE



*All item numbers in the following sections refer to Figure MS-1723-0027-A on the following page unless another figure number is indicated.*

- Remove the retaining ring (61, Fig. MS1723-027A) and the supporting ring (62).
- Using a suitable extractor pull off the wheel (2).
- Remove the retaining ring (45) and the two shims (48, 49).
- Press off the driven shaft (7) in the direction of the drive wheel. **This will inevitably damage the bearing (23).**
- Remove the retaining ring (44) and extract the bearing (23). **The bearing can no longer be used.**
- Remove the retaining ring (43) and extract the bearing (24) via the outer ring.
- Now press out the shaft seal (31).
- Remove the retaining ring (42) and the sealing cover (30).
- Press off the pinion shaft (3) in the direction of the gear unit cover (6). Both bearings (21 and 22) will remain on the pinion shaft.
- Remove the two bearings (21 and 22) from the pinion shaft (3).

### NOTE



*The output gear is part of the motor. The procedure for removing the pinion and the bearings is described in the Drive Motor section on the previous pages.*

## Gear unit assembly

**Replace all bearings and seals. Used bearings and seals will result in premature failure of the unit.**

- Press the bearing (21) into the housing via the outer ring.
- Press the inner ring of the roller bearing (24) onto the drive shaft (7).

- Press the shaft seal (31) from the outside into the seat on the gear unit housing.
- Fit the outer ring of the roller bearing (24) and insert the retaining ring (43).
- Place the bushing (9) onto the rollers of the bearing (24) and press the bearing (23) into the gear unit housing and insert the retaining ring (44).
- Place the wheel (4) in position and guide the drive shaft carefully into the shaft seal. Align the bushing in the process.
- Align the wheel (4) with the tooth shaft profile of the drive shaft (7).
- Support the wheel (4) with suitable bushing and press the drive shaft (7) into the wheel (4).
- Using an appropriate number of shims (49), distance the drive shaft (7) between the two shims (48) so that there is no slack and insert the retaining ring (45).
- Press the bearing (22) onto the pinion shaft (3).
- Hold against the inner ring of the bearing (21) and fit the pinion shaft (3). Press in the retaining ring (42).
- The contact surfaces of the cover and gear unit housing must be clean and oil-free. If necessary, clean the surfaces as described in the Gear Unit Cover Removal section.
- Apply a layer of Dirko® sealant (part no. see chapter one, lubricants) all around the contact surfaces of the gear unit cover.
- Insert the feather key (51) into the pinion shaft (3).
- Hold against the inner ring of the bearing (21) and fit the wheel (2) onto the pinion shaft (3).
- Thread the supporting ring (62) onto the pinion shaft (3) and insert the retaining ring (61).
- Press the sealing cover (30) into the housing.

**Electrical Symbols**

EUROPE	USA	DESCRIPTION	EUROPE	USA	DESCRIPTION
		Wires joining			Hand operated maintained contact
		Wires crossing			Solenoid valve
		Wire connection			Inductor
		Plug / socket			Resistor
		Wire strap			Capacitor
		Terminal board			Potentiometer
		Fuse			Varistor
		Assembled unit			Thermal protector
		Contact, normally open			Lamp
		Contact, normally closed			Horn
		Contact double throw			Battery
		Operating device			Diode
		Operating devices, slow releasing			Breakdown diode
		Operating device, slow operating			LED
		Hand operated push button			Transistor
		Mechanically actuated			MOSFET
		Hydraulically actuated			Thyristor
		Emergency disconnect			Comparator
		Motor armature			

M0056-gb

CLICK HERE TO **DOWNLOAD** THE COMPLETE MANUAL

- Thank you very much for reading the preview of the manual.
- You can download the complete manual from: [www.heydownloads.com](http://www.heydownloads.com) by clicking the link below



- Please note: If there is no response to CLICKING the link, please download this PDF first and then click on it.

CLICK HERE TO **DOWNLOAD** THE COMPLETE MANUAL

## Replacing the SEM0 Traction Controller

### WARNING



**Make sure you are operating the truck with the correct controller.**

**The use of SEM0 traction controllers with different part numbers can change the characteristics and result in accidents.**

When fitting a new SEM0 traction controller in a truck you must select the right truck model through the hardware (on the WP2300 jumper between C2 and C3 and configuration menu selection, on the ST3000 or SX3000 the appropriate selection in the configuration menu).

If you have changed and stored the standard configuration with the programmer, the stored parameters will be loaded the next time the controller is started.

- Prepare to remove the traction controller as previously described in the **Maintenance** section.
- Remove the 4 mounting screws and remove the traction controller.
- Check the contact pattern left behind by the controller back plate on the heat dissipation sheet. The controller must lie fully flat on the heat dissipation sheet. If there are large areas with no contact to the controller, replace the heat dissipation sheet to avoid thermal problems.
- Clean the contact surface of the traction controller on the truck chassis with a lint-free cloth and use an industry-standard silicon removal agent to remove the residue of the heat conducting paste.
- Apply a **thin and even** layer of Dow Corning® 340 heat conducting paste, part no. 053051-008 to the floorboard (= contact surface of the traction controller on the truck chassis).
- Secure the traction controller again with the 4 screws.
- If necessary clean the contact surfaces and refit the power cable (**you must follow the instructions in the Maintenance section on the previous page**) and refit the connectors for the control lines.

- **For cold store versions:** Apply a coat of Dow Corning® 4 Compound, part no. 053051-006, to the control line connectors. Apply a layer of acid-resistant clearseal paint to the controller.

Important: After replacing the controller check and adjust the settings. You can adjust the settings to suit the customer's requirements. Follow the order described as follows.

## Parameter Setting after Replacing the Traction Controller

### Preparatory Measures

- **Power down the truck and jack it up so that the drive wheel is free (see Chapter 1).**
- When the truck is *powered down* connect the programmer to the traction controller.
- Power up the truck.

### Adjustment

1. If required, change the options for the safety reverse switch and the internal service hourmeter of the controller. The standard setting is contained in Table 11-GB. If you have made changes, switch the truck off and on again. This will activate the changes.
2. Measure the battery voltage directly at the battery and adjust the reading measured and displayed by the traction controller (see CONFIG MENU section).
3. Using the TEST menu check the wiring and operation of the switches (see TEST menu section).
4. Re-calibrate the traction potentiometer (see "Traction pod – calibrate potentiometer, PROGRAM VACC menu).
5. Test the traction pod starting point at creep speed. The drive wheel should start when the travel switch closes. If necessary increase the value accordingly. Repeat the test for both travel directions (see PARAMETER CHANGE menu section).

**TESTER Menu**

The following table describes the various truck parameters which can be selected and checked in the TESTER menu.

Menu Item	Description
BATTERY VOLTAGE	Battery voltage measured at key switch input.
MOTOR VOLTAGE	Current applied to armature, measured between +BATT and VMN.
MOTOR CURRENT	Current received by motor armature
FIELD CURRENT	Current received by field coil
VMN	Measures the current between VMN (Volt Motor Negativ) and -BATT. The reading indicates the potential difference over the controller power part.
TEMPERATURE	Controller temperature, measured at the aluminium base plate next to the MOSFETs.
ACCELERATOR	Displays the nominal signal of the traction potentiometer. The left hand side displays the voltage reading, the right-hand side the percentage relating to the maximum operating signal calibrated via PROGRAM VACC.
FORWARD SWITCH	Tests the operation of the "Forward" (FS) switch. Displays the open (OFF) and closed (ON) status.
BACKWARD SWITCH	Tests the operation of the "Reverse" (RS) switch. Displays the open (OFF) and closed (ON) status.
HANDLE/SEAT SWITCH	Tests the operation of the "Override" (ORS) switch. Displays the open (OFF) and closed (ON) status.
QUICK INVERSION	Tests the operation of the "Safety Reverse" (FS) switch. Displays the open (OFF) and closed (ON) status.
CUTBACK SWITCH	Tests the operation of the "Fast / Slow" (FS) switch. Displays the open (OFF) and closed (ON) status.
BRS SWITCH	Tests the operation of the "Brake" (BRS) switch. Displays the open (OFF) and closed (ON) status.
BATTERY CHARGE	Displays the battery charge status as a percentage.

E07-GB

## Charging Errors

### Green LED is not lit

#### Possible Causes:

Socket does not conduct mains supply.

Check whether the socket conducts power supply by plugging in an item of equipment (e.g. lamp etc.) which you know is working.

Faulty mains lead to charger.

Temporarily replace the mains lead to the charger with one which you know is ok. When you finally replace the mains lead avoid damaging the lead when fitting the clamp.

With the AC connected, listen for the operation of the cooling fan. This fan will operate when the charger is delivering current to the batteries. A variation in the speed of the fan is considered normal.

The fan is not always active, see table.

#### Charger faulty.

Replace the charger.

### Green LED flashing

In this case an error has occurred during charging. The charging time in phase I1 or P is too long (time limit exceeded).

#### Possible Causes:

**One or more battery cells faulty.** Repair the battery in accordance with the battery manufacturer's instructions.

**The ambient temperature is too high.** The charger automatically reduces the output capacity in order to avoid a thermal overload. When the ambient temperature is too high the charging current is reduced, which can lead to time limits being exceeded. Also check whether the fan starts up when the mains lead is connected. The air inlet and outlet of the charger must not be covered.

#### Error in charger microprocessor. Reset the microprocessor as follows:

- Remove the mains plug and disconnect the battery.
- Disconnect the charger connections to the earth contact or the pump contactor and fuse F1 and short-circuit the two output leads of the charger.

Alternatively, wait 10 minutes. Then re-connect the charger lead to the battery.

- Re-connect the mains plug.
- Check that the green LED is permanently lit and the charger fan is running.
- If the green LED is not lit and/or the fan is not running, replace the charger.

***Important:*** Before replacing a charger, always check whether the malfunction is due to a temperature problem or the battery.

Faulty battery cells of poorly serviced batteries or charger ambient temperatures above 40 °C are typical causes of faults.

Take into account the fact that the charger emits heat (the temperature of the airflow extracted by the on-board fan is 20 °C above ambient temperature). This heat loss also heats up the environment if the ventilation is inadequate.

If the temperature and battery can both be safely ruled out as possible causes, reset the microprocessor and check if it is possible to charge.

**Calibration for wet batteries**

- Fully charge the battery as indicated by the battery manufacturer in the operating instructions. Measure the acid density in accordance with the battery manufacturer's maintenance instructions to check if the battery is actually 100% charged. Faulty battery cells will make calibration impossible.
- Operate the truck as usual under normal operating conditions until the battery is empty: both LEDs of the BDI will flash and the lift cutout system will be triggered.
- Leave the battery for at least 10 to 12 hours (one hour at the very minimum!).
- After this interval measure the acid density on at least three different battery cells. The smallest recorded value is the one you need.
- Compare the recorded density with the density specified by the manufacturer for an 80% discharged battery (20% residual capacity).
- If the battery is more than 80% discharged (less than 20% residual capacity), set the potentiometer on the back of the BDI to direction **K**.
- If the battery is less than 80% discharged (more than 20% residual capacity), set the potentiometer on the back of the BDI to direction **U**.
- Re-charge the battery and check the calibration. If necessary, repeat this process.

K	L	M	N	O	P	Q	R	S	T	U
1.57	1.63	1.68	1.73	1.78	1.82	1.84	1.86	1.89	1.91	1.93

E20-GB

Wet batteries  
(industrial batteries)

Maintenance-free  
batteries

Symptom	Probable Cause	Remedy
Brakes will not release	<ul style="list-style-type: none"> <li>● Air gap more than 0.2 mm</li> <li>● Brake temperature above 140 °C</li> <li>● Open circuit in brake module circuitry or wiring</li> </ul>	Adjust Allow to cool and check air gap Make voltage checks at test points of the brake module
Brakes drag	<ul style="list-style-type: none"> <li>● Air gap more than 0.2 mm</li> <li>● Brake pad mounting plates or rotor distorted</li> <li>● Armatures movement restricted by dirt, foreign material</li> <li>● Pads soiled with grease</li> </ul>	Adjust Replace Clean with low pressure air Replace
Brakes grab	<ul style="list-style-type: none"> <li>● Incorrect stopping distance adjustment</li> <li>● Brake pad mounting plates or rotor distorted</li> <li>● Brake pads loose or soiled with grease</li> </ul>	Adjust Replace Replace
Abnormal noise and chatter when brakes applied	<ul style="list-style-type: none"> <li>● Brake pad mounting plates or rotor distorted</li> <li>● Brake pads worn out, loose, soiled with grease, foreign material embedded</li> <li>● Rotor thin, cracked, or spline worn</li> </ul>	Replace Replace Replace

B02-GB

**“Rabbit/Turtle” toggle switch**

There are no parts on this switch module that can be repaired. It must be replaced in full.

**This switch module is available in two versions: a standard and a cold store version. Make sure you use the right module!**

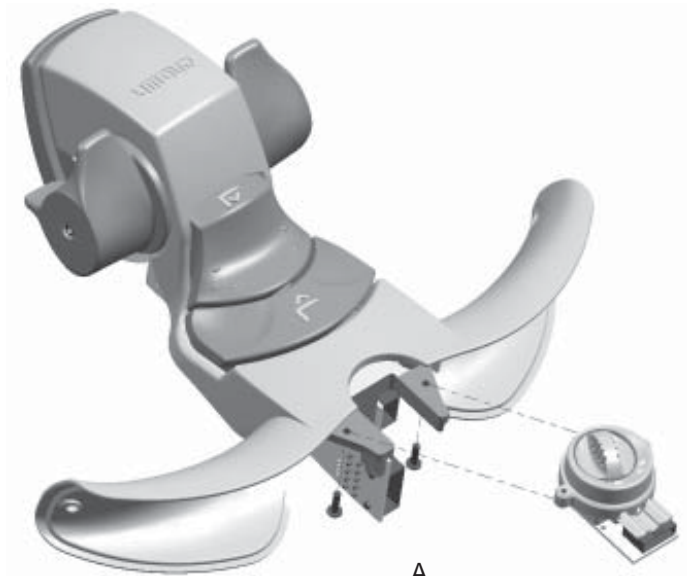

MS511

**Disassembly**

- Remove the switch unit (see SWITCH UNIT section in this chapter).
- Remove the two Torx® screws (A) (see Fig. MS511) and remove the toggle module.

**Assembly**

- Insert a new toggle module and fix it with 2 Torx® screws.
- Refit the switch unit (see SWITCH UNIT section in this chapter). Test the operation.

**Hydraulic PC board**

There are no parts on this PC board that can be repaired. It must be replaced in full.

**This PC board is available in two versions: a standard and a cold store version. Make sure you use the right circuit board!**

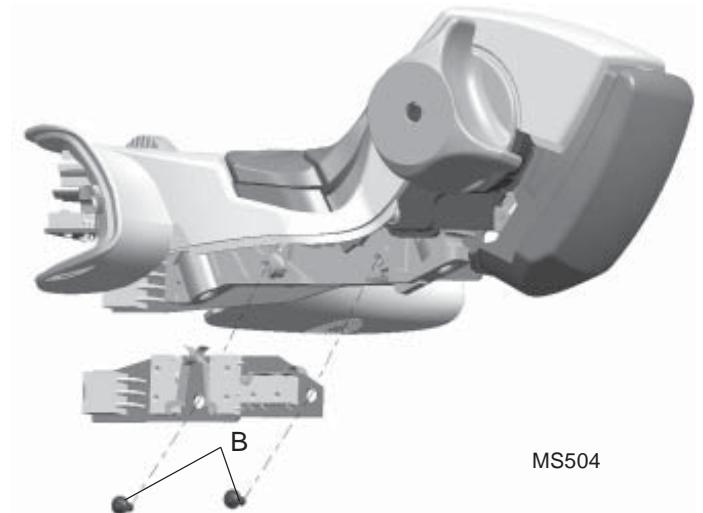

MS504

**Disassembly**

- Remove the switch unit (see SWITCH UNIT section in this chapter).
- Remove the two Torx® screws (B) (see Fig. MS504) from the smaller of the two PC boards (the larger one is the main PC board). Lift out the hydraulic PC board.

**Assembly**

- Insert a new hydraulic PC board (make sure it is the right type, cold store or standard). Fix the board with 2 Torx® screws (B).
- Refit the switch unit (see SWITCH UNIT section in this chapter). Test the operation.

## Fork Carriage Installation

- Chock drive tire and load outrigger wheels.
- Make certain rollers are in good condition and installed on fork carriage. Replace a worn or damaged roller.
- Using a lifting device, raise inner mast, install the fork carriage, and lower inner mast to collapsed height.
- Attach lifting device to fork carriage and raise carriage enough to allow chains and hydraulic supply lines, if applicable, to be connected.
- Connect lift chain(s) to chain anchors or tensioner on fork carriage.
- Remove any pipe plugs or caps that were previously used to seal connections. Then connect all hydraulic lines that were previously disconnected.
- Lower fork carriage and remove lifting device.
- Check lift chain tension and adjust if necessary.
- Install forks.
- Remove chocks.
- Connect the battery and remove the warning tag from the control handle.
- Using a lifting device, raise fork carriage until the top two rollers extend above the mast channel and carriage meets the carriage stop. Then lower carriage slightly below stop to free carriage.
- Using a prybar, carefully force the carriage to one side until its tight against the mast channel. Retain slight pressure to hold carriage in position against mast.
- Using a feeler gage, measure the distance between top roller and mast and record measurement. Acceptable clearance is 0 to 0.76 mm. If clearance is greater than 0.76 mm, additional shims need to be added at this roller location.
- Repeat step 7 on the bottom roller.
- Lower fork carriage completely.
- If clearances were acceptable, proceed to step 14. If clearances were not acceptable, proceed to step 11.
- Remove fork carriage following steps 5 thru 9 outlined under "Fork Carriage Removal".
- Add shims, as necessary, to the appropriate roller locations until clearances are within the acceptable range. If more than one shim is being added at any location, it is recommended that shims be distributed evenly between right and left hand sides of the fork carriage.

## Fork Carriage Adjustment

### **WARNING**



***Wear appropriate safety items, such as safety glasses and shoes, whenever performing maintenance work. To avoid injury, do not place fingers, hands, arms or feet through mast or position them at pinch points.***

- Place key switch in the OFF position, remove key, and disconnect the battery.
- Attach warning tag to control handle to advise others that the truck is being serviced.
- Chock drive tire and outrigger load wheels.
- Remove forks.
- Install fork carriage following steps 3 thru 8 outlined under "Fork Carriage Installation."
- Install forks.
- Remove chocks.
- Connect the battery and remove the warning tag from the control handle.

## Separating Lift Chains

Lift chains are supplied by the meter and must be cut to the required length.

### Tools and Equipment Required

- A secure working plate with a hole slightly larger than the head diameter of a chain bolt. The hole must be deeper than the chain bolt length.
- A bearing ring (washer) with a hole slightly larger than the head diameter of a chain bolt. The bearing ring thickness must be slightly larger than the height of the head of a chain bolt.
- A grinder.
- A hole with a diameter slightly shorter than the chain bolt and a hammer. Or a press with a suitable mandrel.

### Detachment

#### **WARNING**



***Wear protective glasses.***

- Carefully grind the head of the chain bolt. The inner plate surface must not be damaged.
- Place the bearing ring onto the hole in the working plate. The bearing ring prevents the inner plate surface from being damaged when you drive out the chain bolt.
- Place the head of the chain bolt to be driven out into the bearing ring.
- Make sure the chain bolt, the bearing ring and the hole are aligned in the working plate and drive the chain bolt out.

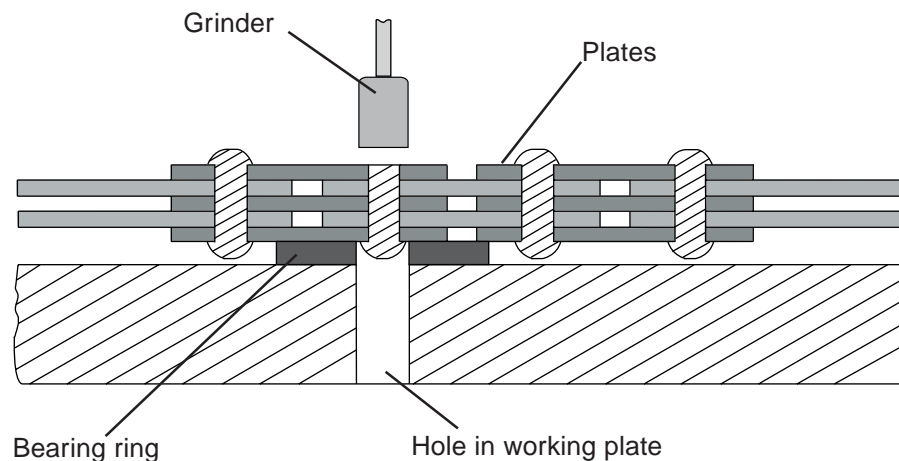

## Cylinders

Two mast lift cylinders are provided on TL mast trucks — one on each side of the outer mast. On TT mast trucks, an additional carriage lift cylinder is provided.

Great care and cleanliness should be exercised in disassembly and assembly of any hydraulic cylinder. Wipe all surfaces clean of dirt and oil before attempting disassembly. Care should be taken when removing the ram from the cylinder. Once disassembly is complete, wash all metallic parts in solvent and blow dry with clean compressed air. Carefully inspect the ram assembly and cylinder bore. Replace if scored, grooved, pitted, or worn. Minor damage to the cylinder bore can be removed with the use of a cylindrical honing tool. Place washed components in a clean container until assembly.

### WARNING



**High pressure hydraulic oil can cause serious injuries.**

**De-pressurise all components before carrying out maintenance work on the hydraulic system.**

**When repairing the hydraulic system always wear protective clothing, goggles and gloves.**

**Whenever a high pressure fluid enters the skin it must be treated as an emergency, even if the skin initially shows no reaction.**

**Physical effects may take time to set in.**

**Secure all connections before re-applying system pressure. Keep hands and body away from any ports as high pressure hydraulic oil can emerge.**

**Use absorbent paper to trace leaks, never use your hands!**

## Mast Lift Cylinder

### Seal Replacement

When excessive hydraulic oil is evident on the cylinder, where the ram exits the cap, one or more of the seals are bad and need replaced. It is recommended that all the seals in the cylinder be replaced whenever a cylinder is removed and disassembled for seal replacement. Follow the procedure outlined below to remove cylinders and replace seals.

- Place key switch in the OFF position, remove key and disconnect the battery.
- Attach warning tag to control handle to advise others that the truck is being serviced.
- Chock drive tire and outrigger load wheels.
- Remove R.H. cylinder cover from bottom of outer mast.
- Disconnect the hydraulic supply line to the R.H. mast lift cylinder. Seal connections to minimize oil loss and prevent hydraulic system contamination.
- Remove retaining ring and shims from the top of the R.H. mast lift cylinder.
- Before removing the R.H. cylinder bracket from outer mast, secure the cylinder to the mast to prevent it from falling when the bracket is removed and the mast is raised. Make certain the device used to secure the cylinder is capable of withstanding the weight of the cylinder. Then remove the R.H. cylinder bracket from the outer mast.
- Repeat steps 4 thru 7 on the L.H. side if that cylinder is being removed for seal replacement.
- Attach a lifting device to the appropriate mast (inner on TL mast trucks, middle on TT mast trucks), raise the mast and remove the mast lift cylinder(s).
- Lower mast to collapsed height.
- Remove cap from cylinder tube.
- Remove bleed screw from cap. Then remove seal from bleed screw and discard seal.

**Traction Controller - Sem0 Power Circuit**

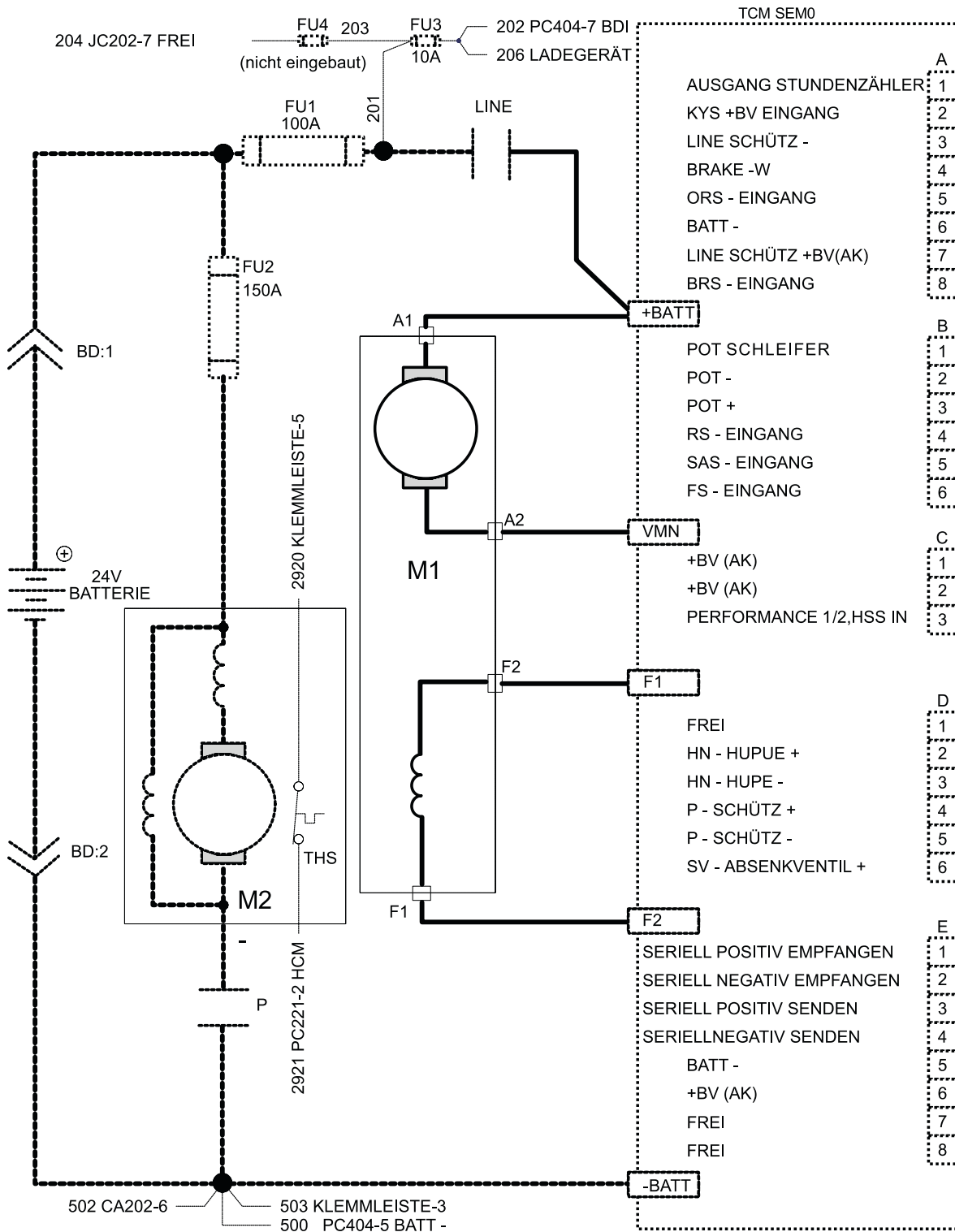

814317\_2C\_3

**Hinweis**

- 1) Spannung zwischen B1 & B2:  
 10V = Max. speed  
 0V = No drive command

CLICK HERE TO **DOWNLOAD** THE COMPLETE MANUAL

- Thank you very much for reading the preview of the manual.
- You can download the complete manual from: [www.heydownloads.com](http://www.heydownloads.com) by clicking the link below



- Please note: If there is no response to CLICKING the link, please download this PDF first and then click on it.

CLICK HERE TO **DOWNLOAD** THE COMPLETE MANUAL