

SF50-75sD/L CMP50-75sD/L

SERVICE MANUAL

RATED CAPACITY : 5000~7500kg

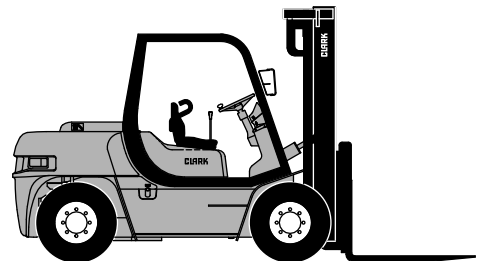

**Part No. 8034927
Manual No. SM690
Rev.2
Jun,2004**

Manufactured by
CLARK Material Handling
Asia

#40-1, Ungnam-Dong,
Changwon-City, Kyungnam,
Korea

CLICK HERE TO **DOWNLOAD** THE COMPLETE MANUAL

- Thank you very much for reading the preview of the manual.
- You can download the complete manual from: www.heydownloads.com by clicking the link below



- Please note: If there is no response to CLICKING the link, please download this PDF first and then click on it.

CLICK HERE TO **DOWNLOAD** THE COMPLETE MANUAL

FOREWORD

This shop manual has been prepared as an aid to improve quality of repairs by giving the serviceman an accurate understanding of the product and by illustrating the correct way to perform repairs and make judgements. Make sure you understand the contents of this manual and use it to the full effect at every opportunity.

This shop manual mainly contains the technical information necessary for operations performed in a service workshop.

For ease of understanding, the manual is divided into sections for each main system of the machine, and the sections are further divided into groups.

SAFETY

- Improper operation and maintenance of this machine could result in serious injury or death.
- Read the Operation and Maintenance Manual carefully BEFORE operating the machine.
- Always keep the Operation and Maintenance Manual and Parts catalogue near the work area.
- Obey precautions concerning flammable liquids, hazardous fluids, oils, lubricants and cleaning solvents.
- To prevent injury to workers, this symbol  is used to mark safety precautions in this manual. The precautions accompanying this symbol should always be followed carefully.
- The specifications contained in this shop manual are subject to change at any time and without any advance notice. Contact your SAMSUNG distributor for the latest information.

HOW TO READ THIS MANUAL

CHAPTER AND SECTION

This manual is issued as a guide to carrying out repair and maintenance. To easily understand this manual it is divided as follows :

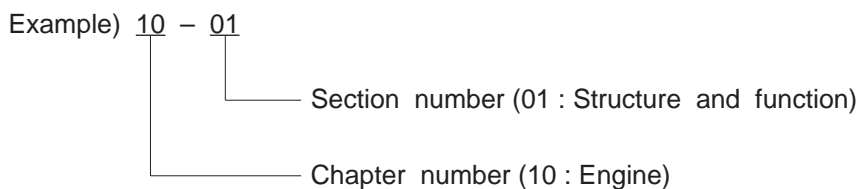

PINCHING AND FALLING

- Do not put your head, hands, arms or feet into the mast.

Entanglement in the mast can cause serious injury.

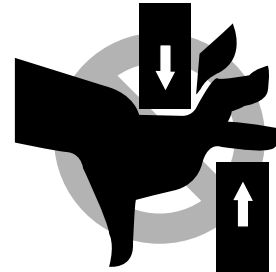

FX028

- Do not use the mast as a ladder.
- Falling from the mast can cause serious injury.

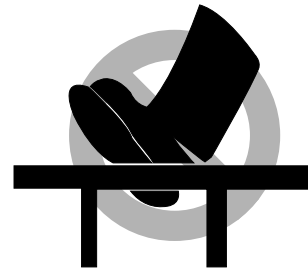

FX030

INFLATING TIRES

- Do not add air pressure immediately to the tires when the air pressure is low. Inspect the rim for damage. If air pressure is added to the tire when the rim is damaged, the tire can be exploded causing serious injury or death.
- Check the valve stem, tread, and side wall for air pressure leaks.
- The tire must be inflated by trained personnel only.
- Make sure there is enough hose to permit the operator to stand away from the safety cage when air pressure is added to the tire.
- Add air pressure to the tires only in a safety cage, as illustrated.
- Always wear safety glasses.

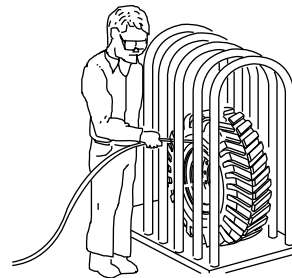

EW013

INSTRUMENT PANEL

01

01

3 ①

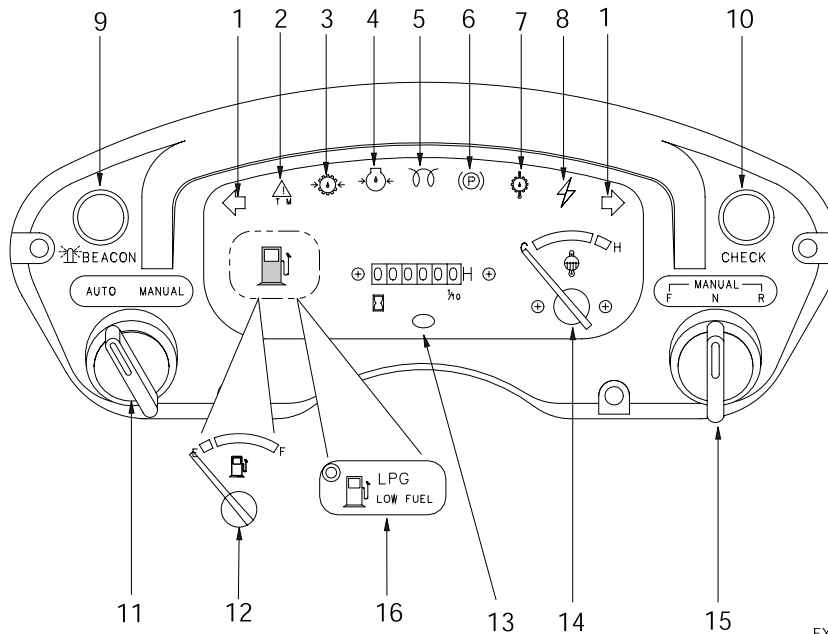

FX987

- | | |
|--|--|
| 1. Turn signal pilot lamps | 8. Battery discharging warning lamp |
| 2. Transmission abnormality warning lamp | 9. Beacon switch (Option) |
| 3. Transmission oil pressure warning lamp | 10. Panel check switch |
| 4. Engine oil pressure warning lamp | 11. Auto / Manual switch |
| 5. Air preheating pilot lamp | 12. Fuel level gauge(Diesel) |
| 6. Parking brake pilot lamp | 13. Hour meter |
| 7. Transmission oil temperature warning lamp | 14. Coolant temperature gauge |
| | 15. Emergency Forward/Reverse switch(Manual operation) |
| | 16. LPG gauge(LPG) |

Item		Unit	Specification		
			CMP50D SF50D	CMP60D SF60D	CMP70D SF70D
Hydraulic system	Main valve	Type	Manual		
		Max. flow rate	l/min		
		Max. pressure	kg/cm ²		
		Relief setting pressure	200	210	
	Main pump	Type	Gear pump		
		Rated pressure	kg/cm ²		
		Displacement	cc/rev		
		R.P.M	rpm		
	Lift cylinder	Quantity	EA		
		Diameter (Bore)	mm	80	85
		Stroke	mm	1495	
	Tilt cylinder	Quantity	EA		
		Diameter (Bore)	mm	100	
		Stroke	mm	237	
Hydraulic tank capacity		l	110		
Attachment	Lift chain	Type	BL1034		BL1044
		Pitch	mm		
		Plate thickness	mm		
		Layers (Total)	EA	7	8
		Pin diameter	mm	11.11	
	Sheave	Chain	EA	2	
	Roller bearing	Mast	EA	4	
		Carriage	EA	6	
	Thrust roller	Carriage	EA	4	
		No. of needle bearing	EA	17/Roller	
Weight of counterweight		kg	2600	3150	3750

TIGHTENING TORQUE

Unit : kgf·m(lbf·ft)

No.	Item	Unit	Torque	
			CMP50/60/70D/75SD SF50/60/70D/75SD	CMP50/60/70L/75SL SF50/60/70L/75SL
1	Mounting bracket, engine	kg·m (ft·lb)	10.2~12.4 (74~90)	
2	Flange, exhaust manifold, engine	kg·m (ft·lb)	4.1~5.1 (30~37)	5.1~6.1 (37~44)
3	Mounting bracket, transmission(Frame)	kg·m (ft·lb)	12.4~13.8 (90~100)	
4	Mounting bracket, transmission(Transmission)	kg·m (ft·lb)	10.7~12.9 (80~93)	
5	Bolt, shift lever	kg·m (ft·lb)	0.5~0.6 (3.5~4.3)	
6	Bolt, mounting bracket, brake pedal and inching pedal	kg·m (ft·lb)	5.8~7.2 (40~50)	
7	Bolt, mounting bracket, brake valvel	kg·m (ft·lb)	24~29.4 (175~210)	
8	Bolt, mounting bracket, inching master cylinder	kg·m (ft·lb)	5.8~7.2 (40~50)	
9	Bolt, brake valve	kg·m (ft·lb)	8~9.8 (58~70)	
10	Bolt, mounting bracket, driving axle	kg·m (ft·lb)	58~66 (420~477)	
11	Bolt, steering axle and silent block	kg·m (ft·lb)	40~50 (290~360)	
12	Bolt, parking brake lever	kg·m (ft·lb)	5.8~7.2 (40~50)	
13	Bolt, silent block	kg·m (ft·lb)	24~29.4 (175~210)	
14	Bolt, mounting bracket, parking brake cable	kg·m (ft·lb)	12.1~14.7 (85~105)	
15	Nut, front wheel	kg·m (ft·lb)	55~60 (400~435)	
16	Nut, rear wheel	kg·m (ft·lb)	45~50 (325~360)	
17	Bolt, pin key, tilt cylinder	kg·m (ft·lb)	4.4~5.4 (32~39)	
18	Bolt, pin key, rod end, tilt cylinder	kg·m (ft·lb)	4.4~5.4 (32~39)	
19	Bolt, rod end and yoke, tilt cylinder	kg·m (ft·lb)	17.4~19.4 (125~140)	
20	Bolt, priority valve	kg·m (ft·lb)	3~3.6 (22~25)	
21	Bolt, mounting bracket, main valve	kg·m (ft·lb)	5.8~7.2 (40~50)	
22	Bolt, main valve	kg·m (ft·lb)	4.4~5.4 (32~39)	
23	Bolt, main pump	kg·m (ft·lb)	9~11 (65~80)	
24	Bolt, auxiliary pump	kg·m (ft·lb)	4.4~5.4 (32~39)	—
25	Bolt, steering unit	kg·m (ft·lb)	3.8~4.6 (27~33)	
26	Bolt, steering column	kg·m (ft·lb)	5.8~7.2 (40~50)	
27	Nut, steering column	kg·m (ft·lb)	7.7~9.3 (55~65)	
28	Bolt, counterweight	kg·m (ft·lb)	45~50 (325~360)	
29	Bolt, engine hood	kg·m (ft·lb)	4.1~5.1 (30~35)	

01

05

1

Description	Thread size	Torque kgf·m(lbf·ft)
Cylinder block		
Capscrew, fitted instead of piston cooling jets	3/8UNF	2.8(20)
Aspiration system		
Nuts, turbocharger to manifold	M10	4.5(33)
Lubrication system		
Plug, lubricating oil sump	3/4UNF	3.5(25)
Capscrews, oil pump to front bearing cap	M8	2.2(16)
Capscrews, cover for oil pump	M8	2.9(21)
Fasteners, lubricating oil sump	M8	2.2(16)
Fuel system		
Nuts, high-pressure fuel pipes	M12	1.9(14)
Capscrew, atomiser	M8	1.2(9)
Capscrew, fuel lift pump	M8	2.2(16)
Nut for gear or fuel injection pump	M14	8.2(59)
Capscrews, for gear of fuel injection pump – AE, YE engines	M8	4.6(33)
Nut, for hub of fuel injection pump – AE, YE engines	M18	10.7(77)
Nuts and capscrews, fuel pump adaptor plate – AE, YE engines	M10	4.5(33)
Nuts and capscrews, fuel pump to adaptor plate – AE, YE engines	M10	4.5(33)
Nuts and flange of fuel injection pump	M8	2.2(16)
Cooling system		
Capscrews, fan drive housing to timing case	M10	4.5(33)
Capscrews, fan drive pulley to hub	M8	2.2(16)
Capscrews, fan	M8	2.2(16)
	M10	4.5(33)
Flywheel and housing		
Capscrews, flywheel to crankshaft	1/2 UNF	10.7(77)
Capscrews, cast iron flywheel housing to cylinder block	M10	4.5(33)
– Stamped 8.8	M12	7.6(55)
– Stamped 10.9	M12	11.7(85)
Capscrews, aluminium flywheel housing to cylinder block	M10	7.1(52)
Electrical equipment		
Nut, alternator pulley :		
– CAV AC5RA and AC5RS	5/8UNF	5.6(40)
– Lucas A127	M17	6.3(45)
– Butec 5524	5/8UNF	8.0(58)

Width of gear and split bush assembly (fitted in position)	30.14/30.16mm (1.186/1.187in)
Inside diameter of flanged bushes (fitted in position)	50.80/50.82mm (1.9998/2.0007in)
Outside diameter of hub	50.70/50.74mm (1.9960/1.9975in)
– With needle roller bearings	54.987/55.000mm (2.1648/2.1654in)
Clearance of bushes on hub	0.058/0.119mm (0.0023/0.0047in)
End float of gear :	
– Production limits	0.10/0.20mm (0.004/0.008in)
– With needle roller bearings	0.24/0.33mm (0.009/0.013in)
– Service limit	0.38mm (0.015in)
Backlash for all gears	0.08mm (0.003in) minimum

10

02

13

CYLINDER BLOCK ASSEMBLY

• Cylinder block

Height between top and bottom faces	441.12/441.33mm (17.367/17.375in)
Diameter of parent bore for cylinder liner	104.20/104.23mm (4.103/4.104in)
Depth of recess for flange of cylinder liner	3.81/3.91mm (0.150/0.154in)
Diameter of recess for flange of cylinder liner	107.82/107.95mm (4.245/4.250in)
Diameter of parent bore for main bearing	80.416/80.442mm (3.1660/3.1670in)

Camshaft bore diameter :

AA, AB, AC, AD, AE

Number 1 (for bush)	55.56/55.59mm (2.188/2.189in)
Number 2	50.55/50.60mm (1.990/1.992in)
Number 3	50.04/50.09mm (1.970/1.972in)
Bore of bush for number 1 camshaft journal	50.79/50.85mm (2.000/2.002in)

• Cylinder liners

Type

– Production	Dry, interference fit, flanged
– Service	Dry, transition fit, flanged
Outside diameter of production liner	104.25/104.28mm (4.105/4.106in)
Interference fit of production liner	0.03/0.08mm (0.001/0.003in)
Inside diameter of production liner	100.00/100.03mm (3.937/3.938in)
Transition fit of service liner	± 0.03mm (± 0.001in)
Inside diameter of service liner (fitted)	100.04/100.06mm (3.9385/3.9395in)
Maximum permissible wear of liner bore	0.25mm (0.010in)
Thickness of flange	3.81/3.86mm (0.150/0.152in)
Relative position of top of liner flange to top face of cylinder block	0.10mm (0.004in) above 0.10mm (0.004in) below

- Remove the rocker assembly.
- Fit the valve spring compressor(A1) and the relevant adaptor (A2 or A3).
- Compress the valve spring(s) and remove the collets. Ensure that the valve springs are compressed squarely or damage to the valve stem can occur.
- Release the valve spring compressor and remove the valve spring caps and valve spring (s).

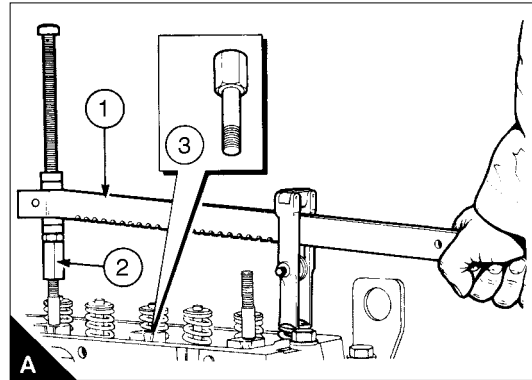

⚠ Attention

Do not turn the crankshaft while the valve springs are removed.

- Put the new valve springs in position. If double valve springs are fitted, ensure that the closed damper coils are towards the cylinder head.
- Fit the valve spring caps.
- Fit the valve spring compressor, compress the valve springs and fit the collets. Ensure that the valve springs are compressed squarely or damage can occur to the valve stem. Remove the valve spring compressor.
- Fit the rocker assembly.
- Check the valve tip clearances.
- Fit the rocker cover.

If other or all of the valve springs are to be changed, they can be changed two cylinders at a time. The pairs of cylinders are : engine types AA, AB, AC, AD : -1 and 4, 2 and 3 : engine types YA, YB, YC, YD : -1 and 6, 2 and 5, 3 and 4.

If the rocker assembly has been removed, piston TDC can be found as follows : Fit the valve spring compressor and compress the valve springs to open the valve.

Turn the crankshaft, by hand, in the normal direction of rotation until the piston touches the valve.

Continue to turn the crankshaft, and at the same time, release pressure on the valve spring compressor until the piston is at TDC(B).

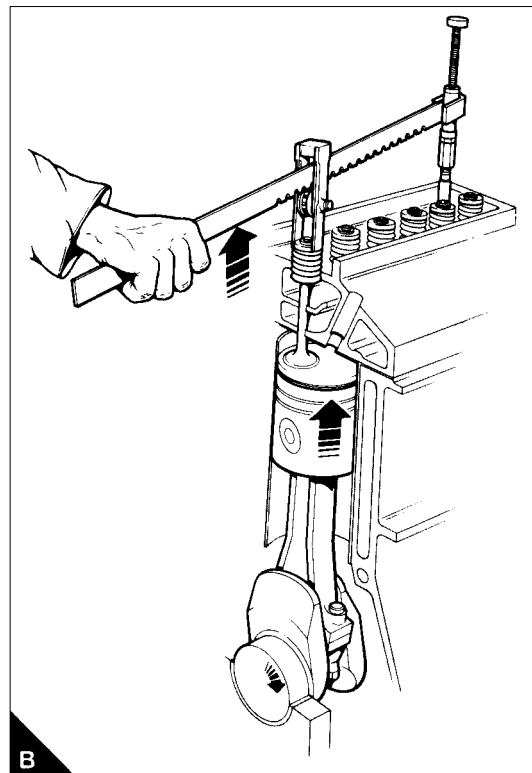

PISTONS AND CONNECTING ROD ASSEMBLIES

GENERAL DESCRIPTION

The "Quadram" combustion chamber in the top of the piston is specially designed to give an efficient mix of fuel and air.

The pistons have two compression rings and an oil control ring. The groove for the top ring has a hard metal insert to reduce wear of the groove. Axial location of the fully floating gudgeon pin is by circlips. There is a steel insert in the piston skirt to control piston expansion.

⚠ Some naturally aspirated engines have pistons that do not have an insert in the groove for the top ring. Also the skirt of the piston does not have an insert to control expansion. These pistons are used in applications where the full engine power is not used.

Turbocharged engines, which are rated higher than 2300 rev/min, have an "anodised area" on the top face of the piston.

Turbocharged engines have cooling jets fitted in the cylinder block to spray lubricating oil onto the inner surface of the piston.

The connecting rods are machined from "H" section forgings of molybdenum steel. Generally, the location of the bearing caps to the connecting rods is made by serrations and the cap is retained by two nuts and bolts (A). AE and YE engine types have wedge shaped small ends and dowels / capscrews in the bearing cap (B).

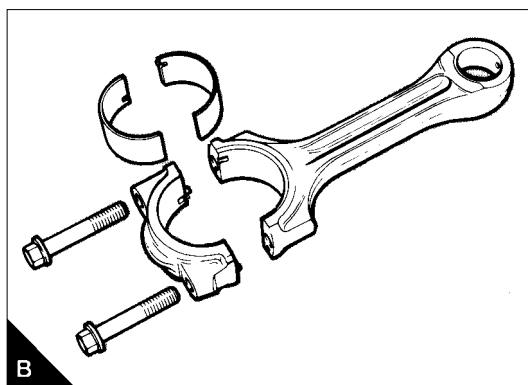
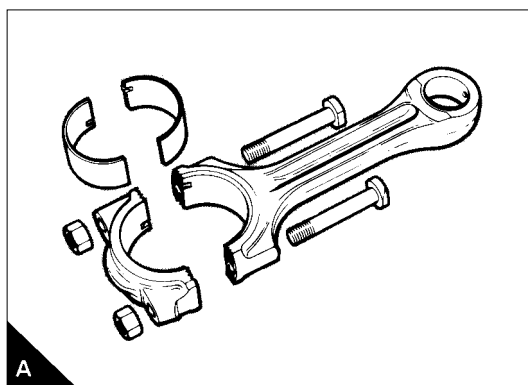

BIG END BEARING

TO REMOVE AND TO FIT

To remove

- Drain the engine lubricating oil.
- Remove the lubricating oil sump.
- Remove the lubricating oil strainer and suction pipe or remove the balancer unit.
- Turn the crankshaft until the relevant connecting rod is at its lowest position.
- Release the nuts and remove the bearing cap. Remove the bolts from the connecting rod.
- Remove the lower half bearing from the cap but keep it with its relevant cap.

TO RENEW THE REAR OIL SEAL – ENGINES WHICH HAVE THE STANDARD SEAL

Special tools :

Replacer tool for rear oil seal, PD.145D

There are four positions in which the seal can be fitted in the housing (A).

Position "1" is used in the factory or if a new seal is fitted on a new or reground crankshaft in service.

Position "2" is used when a new seal is fitted in service and the crankshaft flange is worn in position "1".

Position "3" is used when a new seal is fitted in service and the crankshaft flange is worn in position "1" and "2".

Position "4" can also be used with a new seal in service, if a wet clutch is not used.

If all positions have been used it is permissible to grind the crankshaft flange.

- Remove the seal and housing assembly.
- Put the engine side of the housing on suitable support and press out the seal with a suitable adaptor.
- Lubricate the outer circumference of the seal and the bore of the seal housing with clean engine lubricating oil.
- Put the engine side of the housing on a suitable support and put the seal into position on the flywheel end of the bore with the spring of the seal towards the housing.
- Press the seal into the housing to the correct position with the relevant side of the tool.

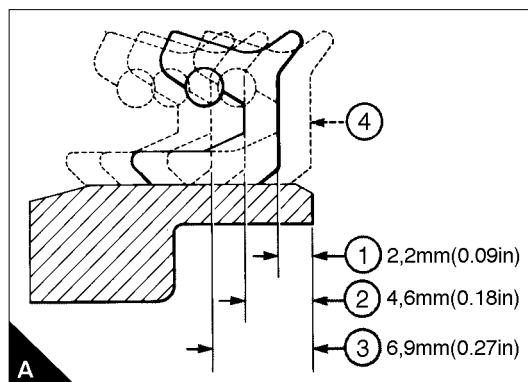

- For engines that use the idler gear assembly with needle roller bearings—inspect the components for wear and other damage and renew them as necessary. Lightly lubricate the components with clean lubricating oil before assembly onto the hub. Fit the hub (D8) as shown in paragraph 1. Put the rear spacer (D7) in position on the hub. Put the rear thrust washer (D6) in position the rear spacer. Put the bearings (D5) in position on the hub in the same position as they were originally. Lightly lubricate the bore and thrust washer faces of the gear (D4) with clean lubricating oil and put the gear in position on the bearings. Put the front spacer (D3) in position on the hub then put the front thrust washer (D2) in position on the spacer. Put the plate (D1) in position, the plate has TOP stamped on the front face as the holes in the plate are not equally spaced. Fit the capscrews and tighten to :

 44 N·m (33 lbf·ft) 4.5 kgf·m.

- Check the idler gear end-float and the timing gear backlash.
- Fit the timing case cover.
- Fit the water pump.
- Fit the crankshaft pulley.
- Where necessary, fit the fan drive pulley.
- Fit the drive belts and adjust the belt tension.
- Fit the fan.
- Fill the cooling system.

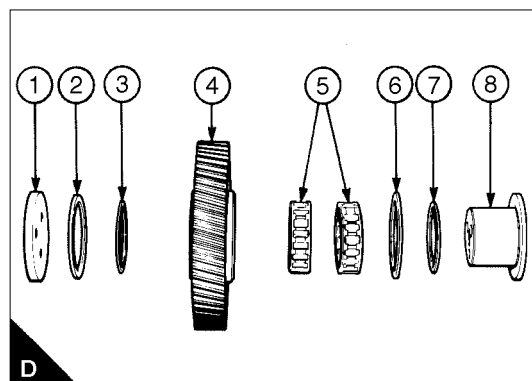
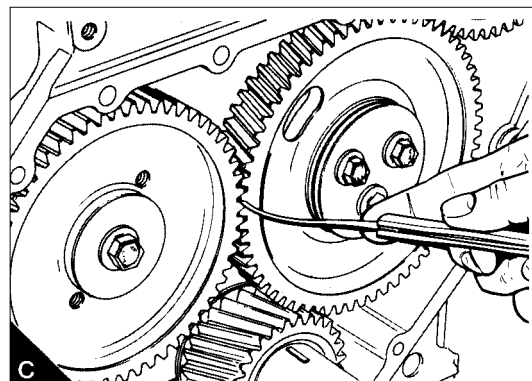
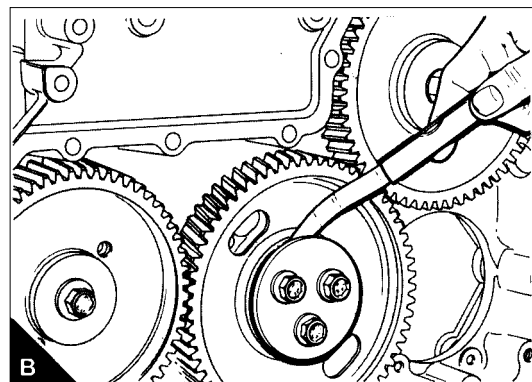
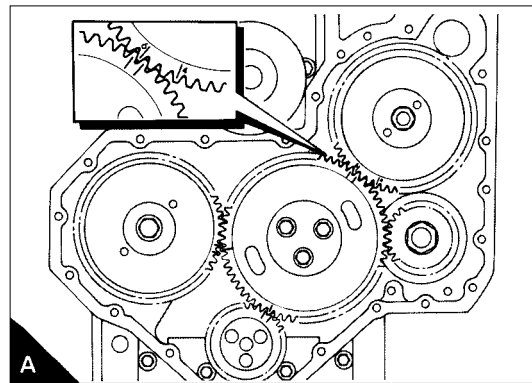

10

06

5

TO REMOVE GLAZE FROM THE BORE

A tool, known as a 'Flex-Hone', is available to correct the liner surface. This tool can be used with an electric hand drill at low speed. The pistons and connecting rods must be removed and the piston cooling jets, where fitted, must also be removed. Use covers to protect all engine components from the debris which is caused during the process.

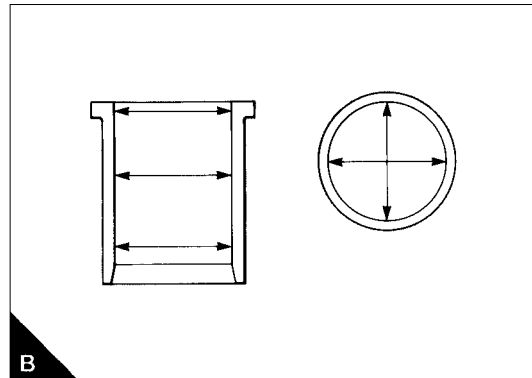

Details and supply of the 'Flex-Hone' are available from :
 Nicro (Leamington) Ltd.
 Unit One
 South Woodchester Trading Estate
 Stroud
 Gloucestershire GL5 5NR

- Grade 80SC 'Flex-Hone' is to be used. A 4 in or 4 1/8 in size 'Flex-Hone' can be used according to how badly the bore is glazed.
- New 'Flex-Hone' must be operated in an old liner before use on an engine to remove all loose material and sharp edges.
- Lubricate lightly the liner and the 'Flex-Hone' with clean engine lubricating oil.
- Put the tool in position on top of the liner, but do not press the tool into the liner until the tool is operated.
- Operate the tool and move it up and down the liner bore once a second for 30-50 seconds. Remove the tool while it rotates.
- Clean thoroughly the liner bore to remove all dirt from the operation, use a hard brush and solvent.
- Dry the liners and remove carefully all the covers used to protect the components. Clean thoroughly all the engine components which have been affected by debris.
- Fit the piston cooling jets or the plugs. Ensure that new piston rings are fitted when the engine is assembled in accordance with the relevant sections of this workshop manual.

⚠ Attention

After a glazed bore has been corrected, these recommendations are advised for the first 240 Km (150 miles) or 5 hours of operation :

- **Do not operate the engine at full load.**
- **Do not operate the engine at high speed.**
- **Do not allow the engine to run at low idle speed for extended periods.**

LUBRICATION SYSTEM

GENERAL DESCRIPTION

For four cylinder engines the lubrication system is as follows :

Pressure lubrication is supplied by a rotor type pump which is driven through an idler gear from the crankshaft gear. The pump has an inner rotor and an outer rotor which are off-center to each other. There is a key between the inner rotor and the drive shaft. The inner rotor has six lobes which mesh with the seven lobes of the outer rotor. When the pump turns, the space between the lobes of the outer rotor which are in mesh increases to cause a suction or decreases to cause a pressure increase. If a balancer unit is fitted, the oil pump is fitted to the balancer frame and is driven by the balancer drive shaft.

Lubricating oil from the sump passes through a strainer and pipe to the suction side of the pump.

The lubricating oil passes from the outlet side of the pump through a pipe to a relief valve, which is fitted to the bottom of the left side of the cylinder block. If a balancer unit is fitted, the relief valve is fitted in the frame of the balancer. The relief valve opens if the oil pressure is too high : this allows some of the lubricating oil to return to the sump.

From the relief valve, lubricating oil passes to a plate type oil cooler (some naturally aspirated engines do not have an oil cooler). The oil cooler is either fitted to the left side of the cylinder block and has seven plates, or it is fitted between the oil filter head and the filter canister and has ten plates. Some oil coolers are fitted with a bypass valve. If cold oil increases the restriction in the cooler, the bypass valve opens and the oil passes directly from the inlet side to the outlet side of the cooler.

Lubricating oil from the oil cooler, passes to an oil filter. The oil filter can be fitted to the left or right side of the engine. If the filter is fitted to the right side of the engine, the oil passes through a pipe connected between the relief valve and the right side of the cylinder block. The oil passes from the pipe through a passage in the right side of the cylinder block to an oil cooler and then to the oil filter.

When the oil filter is on the right side of the engine, and an oil cooler is fitted, the oil cooler will be between the oil filter head and the oil filter canister.

The lubricating oil passes from the filter to the pressure rail which is drilled the complete length of the left side of the cylinder block. If the oil filter is on the right side of the engine, the oil passes through a passage drilled across the cylinder block to the pressure rail.

From the pressure rail, lubricating oil passes to the main bearings of the crankshaft and through passages in the crankshaft to the big end bearings. The pistons and the cylinder bores are lubricated by splash and oil mist.

Lubricating oil passes from the main bearings through passages in the cylinder block to the journals of the camshaft. Lubricating oil passes, at a reduced pressure, from the center journal of the camshaft through a passage in the cylinder block and cylinder head to the rocker shaft. The oil passes through a passage in the rocker shaft to the bearings of the rocker levers. The valve stems, valve springs and the tappets are lubricated by splash and oil mist.

FUEL SYSTEM

GENERAL DESCRIPTION

Engines used for agricultural and industrial applications have CAV fuel injection pumps. Naturally aspirated engines have CAV DPA fuel pumps. Some engines are fitted with fuel injection pumps which have a self-vent feature. Both the Bosch (A, B) and CAV(C) fuel injection pumps have mechanical governors to control the engine speed.

The "low spring" atomisers receive high pressure fuel from the fuel injection pump and inject this fuel into the combustion chamber of the pistons as a very fine spray. The atomisers are set in the factory, but they must be checked in accordance with the preventive maintenance schedules. The pressure at which atomisers operate can be adjusted by a change of shims fitted above the spring.

The fuel injection equipment must only be checked and adjusted by personnel who have had the correct training.

The fuel lift pump is of the diaphragm type and is mechanically driven. It is fitted on the right side of the cylinder block and is driven by an eccentric on the camshaft. The pump is fitted with a priming lever.

There are two types of fuel filter element in use: The separate element type where the filter element is held between the filter head and the bottom cover.

The canister type where the filter element has an internal thread at the top and is fastened to a threaded adaptor in the filter head.

⚠ Attention

It is very important that dirt does not enter the fuel system. Before a connection is disconnected, clean thoroughly the area around the connection. After a component has been disconnected, fit a suitable cover to all open connections.

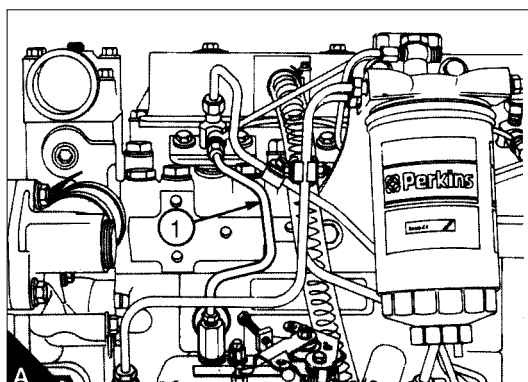
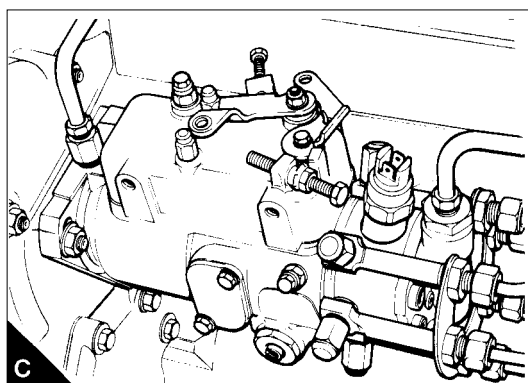
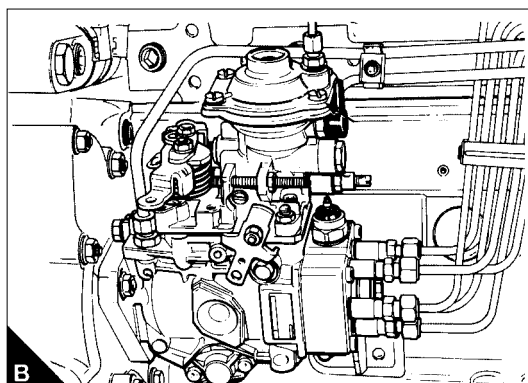
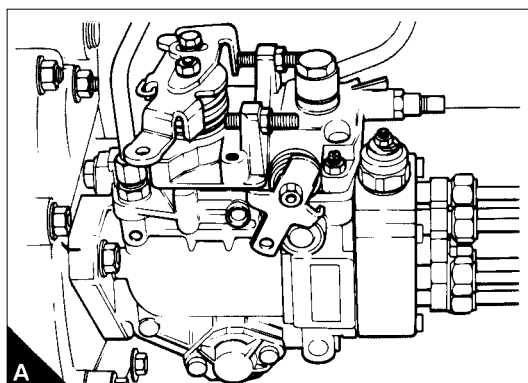

10

10

1

COOLING SYSTEM

GENERAL DESCRIPTION

Coolant from the bottom of the radiator passes through the centrifugal water pump which is fitted on the front of the timing case. The pump is gear driven from the gear of the fuel injection pump and assists the flow of the coolant through the system. From the pump, the coolant passes through a passage in the timing case to the front of the cylinder block.

On four cylinder engines the coolant passes through a passage in the left side of the cylinder block to the rear of the cylinder block. Where a lubricating oil cooler is fitted, some of the coolant passes around the element of the cooler and then to the rear of the cylinder block. Some four cylinder engines have a plate type oil cooler fitted between the oil filter canister and the oil filter head. If the oil cooler is fitted on the left side of the engine, coolant from the bypass connection at the rear of the water pump passes through a pipe to the oil cooler. If the oil cooler is fitted to the right side of the engine, a pipe is connected between the thermostat housing and the oil cooler. The coolant passes around the plates of the cooler and passes through a pipe to the cylinders block. The coolant then passes around the cylinders and up into the cylinder head. The coolant leaves the cylinder head at the front and passes into the thermostat housing. If the thermostat is closed, the coolant goes directly through a bypass to the inlet side of the water pump. If the thermostat is open, the thermostat closes the bypass and the coolant passes to the top of the radiator.

On six cylinder engines the coolant divides as it enters the cylinder block. Most of the coolant passes along the right hand side of the cylinder block and around the outside of the cylinders to the rear of the cylinder block. The remainder of the coolant passes along a passage on the left hand side of the cylinder block to the lubricating oil cooler. The coolant flows around the element of the lubricating oil cooler to the rear of the cylinder block. The coolant then passes to the rear of the cylinder head.

Coolant passes forward through the cylinder head and into the thermostat housing. These engines have two thermostats. If the thermostats are closed, the coolant goes, through a bypass, directly to the inlet side of the water pump. If the thermostats are open, the coolant passes to the top of the radiator.

THERMOSTATS

TO REMOVE AND TO FIT

To remove

- Drain the cooling system so that the coolant level is below the thermostat position and disconnect the top hose from the water outlet connection.
- Release the capscrews and remove the water outlet connection.
- Remove the thermostat (s) (A).

10

11

1

ELECTRICAL EQUIPMENT

PRECAUTION

To prevent damage to the diodes and to the resistors, the precautions given below must be followed.

- Do not disconnect the battery while the engine is in operation. This will cause a voltage surge in the alternator charge system which will immediately cause damage to the diodes or to the transistors.
- Do not disconnect an electrical wire before the engine is stopped and all electrical switches are in the "off" position.
- Do not cause a short circuit by the connection of electrical wires to the wrong terminals. The correct identification of the electrical wire to the correct terminal must be made. A short circuit or wrong connection which gives reverse polarity will immediately cause permanent damage to the diodes and to the transistors.
- Do not connect a battery into the system until it has been checked for correct polarity and voltage.
- Do not check for current flow with a spark contact as damage can be caused to the transistors.

DRIVE BELTS

TO CHECK

- Check the belt (s) for wear and damage and renew the belt (s), if necessary. If twin belts are fitted, they should both be renewed.
- Check the belt tension. If twin belts are fitted, check/adjust the tension on the tighter belt. To ensure maximum belt life, it is recommended that a belt tensioner gauge is used. Fit the gauge (A) at the center of the longest free length and check the tension. If a "Burroughs" gauge is used, the correct tension is 355 N (80 lbf) 36 kgf. If the tension is equal to or less than 220 N (50 lbf) 22 kgf, adjust it to 355 N (80 lbf) 36 kgf. If no gauge is available, press down the belt with the thumb at the center of the longest free length and check the deflection (B). With moderate thumb pressure, 45 N (10 lbf) 4.5 kgf, the correct belt deflection is 10 mm (3/8 in).

10

13

1

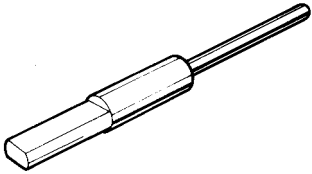
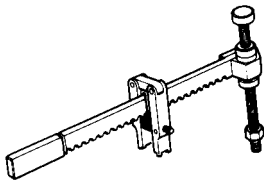
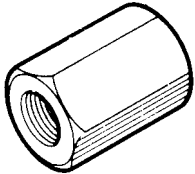
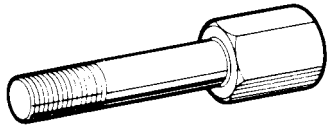
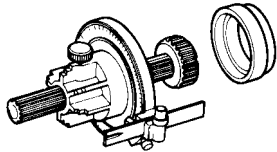
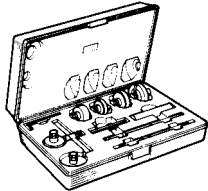
Number	Description	Illustration
PD.221	Piston position probe.	
PD.6118B	Valve spring compressor.	
PD.6118-7	Stud adaptor for use with PD.6118B.	
PD.6118-8	Capscrew adaptor for use with PD.6118B.	
MS.67B	Timing gauge.	
MS.73A	Set of adjustable cutters for valve seats.	

GENERAL INFORMATION

INTRODUCTION

This workshop manual has been written to provide assistance in the service and overhaul of Perkins New 1000 Series engines. For overhaul procedures the assumption is made that the engine is removed from the application.

The engine conforms with USA (EPA/CARB) stage 1 and EEC stage 1 emissions legislation for agricultural and industrial applications.

Most of the general information which is included in the relevant User's Handbook (sections 1 to 9) has not been repeated in this workshop manual and the two publications should be used together.

Where the information applies only to certain engine types, this is indicated in the text.

The details of some operations will be different according to the of fuel injection pump which is fitted. The specific pump type used can be found by reference to the manufacturer's identification plate on the pump body. Generally, the type of pump fitted is as shown below.

Lucas DP200 Series

When reference is made to the "left" or "right" side of the engine, this is as seen from the flywheel end of the engine.

Special tools have been made available and a list of these is given in section 25. Reference to the relevant special tools is also made at the beginning of each operation, where relevant. POWERPART recommended consumable products are listed in section 10. Reference to the relevant consumable products is also made at the beginning of each operation, where relevant. Data and dimensions are included at the end of each section.

Read and remember the "Safety precautions".

They are given for your protection and must be used at all times.

Danger is indicated in the text by two methods :

 **This indicates that there is a possible danger to the person.**

 **This indicates that there is a possible danger to the engine.**

Note :

Is used where the information is important, but there is not a danger.

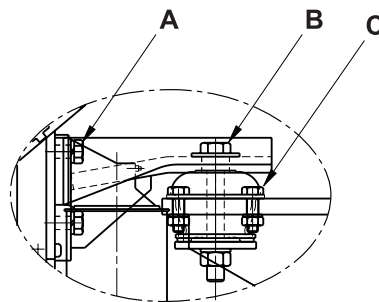
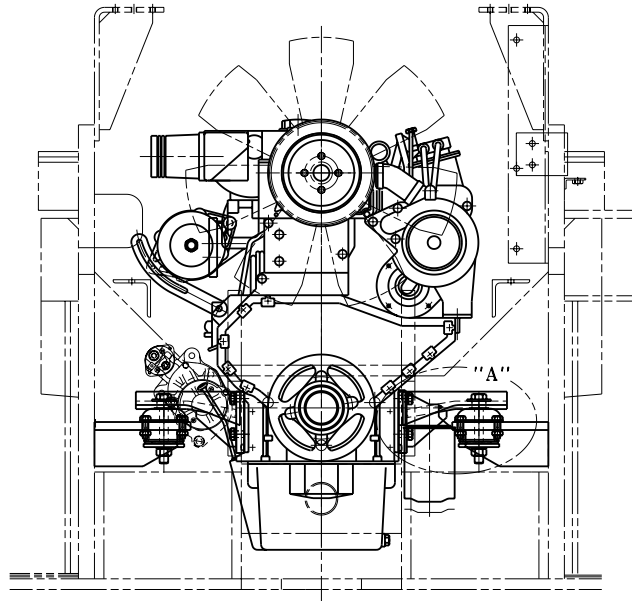

SPECIFICATIONS

ENGINE MOUNT - RECOMMENDED TORQUE



DETAIL A

Unit : kgf·m (lbf·ft)

	Spec.		
A	M12×1.75×35L	13.1~16.1 (95~116)	Loctite 542
B	M16×2.0×120L	12.4~13.8 (89~100)	-
C	M10×1.5×40L	5.1~6.1 (37~44)	-

Item	Undersize		
	0.25 mm (0.010 in)	0.51 mm (0.020 in)	0.76 mm (0.030 in)
1	75.905 / 75.926 mm (2.9884 / 2.9892 in)	75.651 / 75.672 mm (2.9784 / 2.9792 in)	75.397 / 75.418 mm (2.9684 / 2.9692 in)
2	63.216 / 63.236 mm (2.4888 / 2.4896 in)	62.962 / 62.982 mm (2.4788 / 2.4796 in)	62.708 / 62.728 mm (2.4688 / 2.4696 in)
3	39.47 mm (1.554 in) maximum	—	—
4	37.82 mm (1.489 in) maximum	—	—
5	44.68 mm (1.759 in) maximum	—	—
6	40.55 mm (1.596 in) maximum	—	—
7	133.17 mm (5.243 in) minimum	—	—
8	Do not machine this diameter	—	—
9	3.68/3.96 mm (0.145/0.156 in)	—	—

Surface finish for journals, crank pins and fillet radii must be 0.4microns (16 micro inches).
 Surface finish for seal area of crankshaft palm must be 0.4/1.1microns (16/43micro inches).
 With the crankshaft on mountings at the front and rear journals, the maximum run-out (total indicator reading) at the journals must not be more than shown below.

Journal	4 cylinder crankshafts
1	Mounting
2	0.08 mm (0.003 in)
3	0.15 mm (0.006 in)
4	0.08 mm (0.003 in)
5	Mounting
6	—
7	—

Run-out must not be opposite. The difference in run-out between one journal and the next must not be more than 0.10 mm (0.004in).

Run-out on the crankshaft pulley diameter, rear oil seal diameter and the rear flange diameter must not be more than 0.05 mm (0.002in) total indicator reading.

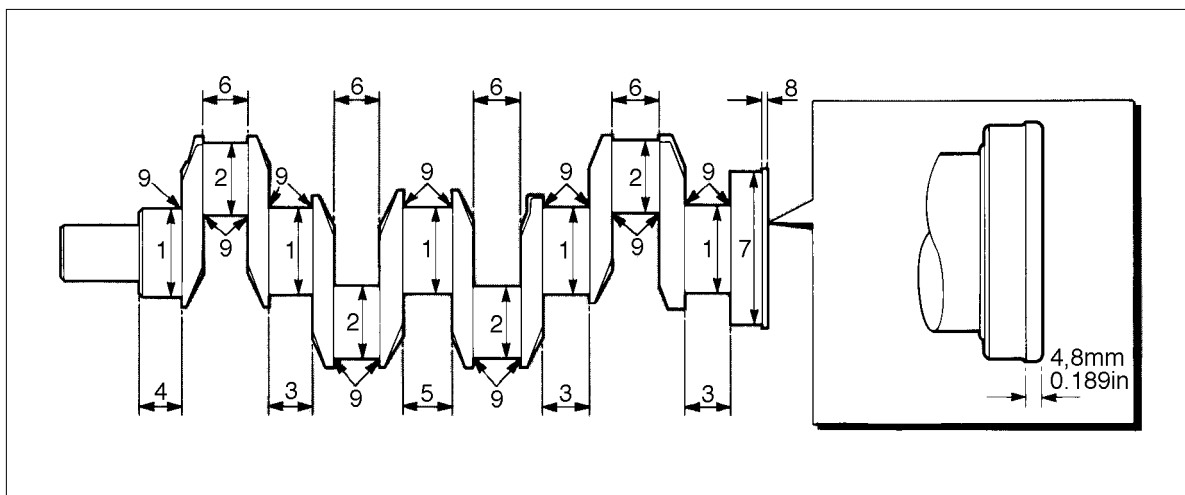

ELECTRICAL EQUIPMENT

The information which follows is general and can change with individual applications.

• **Alternators**

Mando Industries co., Ltd.

- Rated voltage..... 14.7±0.3V (Ambient temperature :
20°C 5000 rpm, Load 5A or less)
- Temperature compensation..... –7±3m V/°C
- Max. rpm..... 13500 rpm
- Weight..... 4.7 kg

• **Starter motors**

- Make and type Delco Remy 28MT171
- Offset gear reduction 3.875 : 1
- Flange type SAE No.1
- Performance curve C-7136
- Current rating 700 amps
- Weight..... 8 kg

• **Starting aid**

- Type..... Fuel fed, electrically operated heater
- Voltage..... 12V (dropping resistor used on 24V
system)
- Flow rate of fuel through starting aid 3.5/5.9 m l /min

- Fit the fuel filter and the bracket. Fit the low-pressure fuel pipes between the fuel injection pump and the fuel filter.
- Fit the coolant by-pass connection ; tighten the capscrews and hose clip.
- If a compressor is fitted : Fit the coolant pipe between the cylinder head and the compressor. Then fit the pipe between the coolant by-pass and compressor.
- AA : Fit the oil cooler.
- Fit the induction and exhaust manifolds :

Note :

The manifold joints are fitted without jointing compound.

Ensure that the two inlet and exhaust manifold joints (A1) and (A2) are fitted correctly, the rear joint (A1) must be fitted with the two location tabs (A3) towards the sump. Fit the joints without jointing compound. The latest joints are supplied as one piece.

⚠ Damage to the exhaust manifold can occur if it is not aligned and tightened correctly.

Some exhaust manifolds have large clearance holes for the fasteners, if these manifolds are renewed it is important that the two alignment bushes (B2), supplied with the new manifold, are in position.

New alignment bushes are not necessary when the original manifold is removed and fitted.

- Fit the exhaust manifold. Tighten the manifold fasteners evenly and gradually to 44 Nm (33 lbf-ft) 4.5 kgf-m in the sequence shown in (B). The front of the engine is shown by the arrow (B1).
- Repeat paragraph 18 to ensure that all the fasteners are tightened to the correct torque.
- Fit the induction manifold. Tighten the manifold fasteners evenly and gradually to 44 Nm (33 lbf-ft) 4.5 kgf-m.

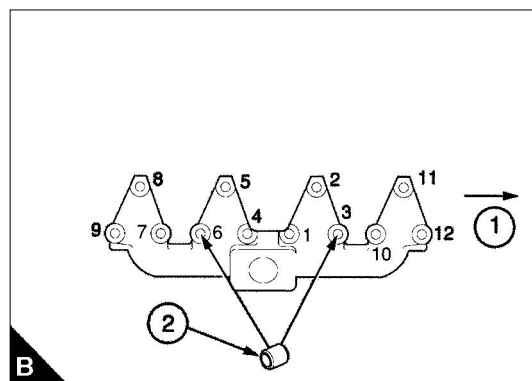
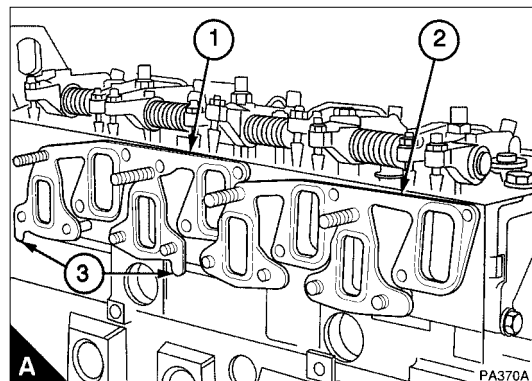
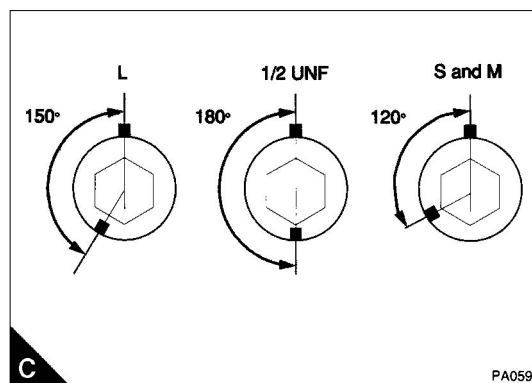
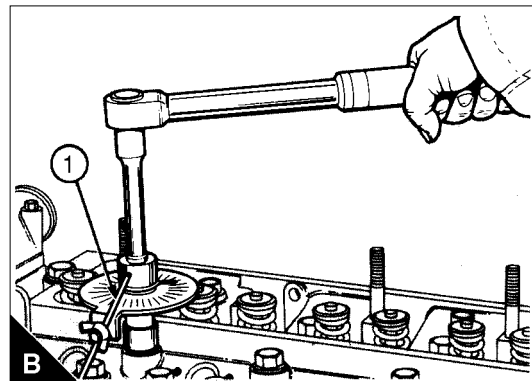

PISTON AND CONNECTING ROD ASSEMBLIES

GENERAL DESCRIPTION

The pistons used in the New 1000 Series engines have a “Fastram” combustion chamber in the top of the piston (B). The piston (B) for engine has two recesses in the top face for the valves. The combustion chamber is designed to give an efficient mix of fuel and air.

The pistons and connecting rods are matched to the relevant cylinder.

The pistons have two compression rings and an oil control ring. The groove for the top ring has a hard metal insert to reduce wear of the groove. The piston skirt has a layer of graphite to improve the wear characteristics.

Axial location of the fully floating gudgeon pin is by circlips. The gudgeon pin is off-centre to reduce the noise level.

Piston cooling jets are fitted in the cylinder block to spray lubricating oil onto the inner surface of the pistons.

Note :

Engine types AR and AS have only one cooling jet fitted to spray the number one piston.

The correct piston height is important to ensure that the piston does not contact the cylinder head and to ensure the efficient combustion of fuel.

The piston height is controlled by the length of the connecting rod. In the factory there are six length grades of connecting rods and one piston are used to obtain the correct piston height. To obtain the different grades, the small-end bush is machined off-centre. The amount that the bush is off-centre gives the different length grades.

In service, a partially finished small-end bush is available, which can be fitted to the original connecting rod and machined to obtain the correct length grade, refer to operation 15-04-10. Specialist equipment and personnel with the correct training are needed to machine the partially finished small-end bush. Connecting rod kits are also available with the small end bush fitted and machined to obtain the correct connecting rod grade. For further information refer to your nearest Perkins distributor.

Notes :

- If the crankshaft or the cylinder block is to be renewed, it may be necessary to change the grade of the connecting rods, operation 15-04-10. This will occur if the correct piston height above the cylinder block face cannot be maintained with the original connecting rod assemblies, operation 15-04-5.
- Engine types AR and AS do not have cylinder liners fitted and the cylinder bores must be machined oversize to correct a worn cylinder bore. Two oversize pistons and piston rings are available in service 0.5 mm (0.020 in) and 1.00 mm (0.040 in).

Notes :

Always use the engine identification number to order new parts.

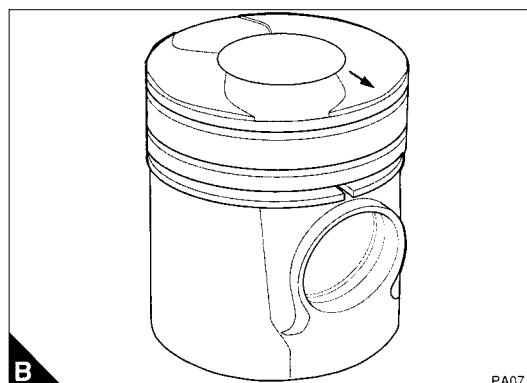

12

04

1

PISTON COOLING JETS

TO REMOVE AND TO FIT

To remove

Release the valve assembly and remove the piston cooling jet assembly (A). (The crankshaft is removed in A to show clearly the piston cooling jet)

To fit

- Check that the ball moves freely against spring pressure in the valve assembly and that the jet tube is not damaged. Renew the valve assembly and/or the body as necessary.
- Fit the piston cooling jet; ensure that the assembly is fitted correctly on the dowel (A1) in the cylinder block.

Tighten the valve assembly :  20N·m (15 lbf·ft) 2.0kgf·m

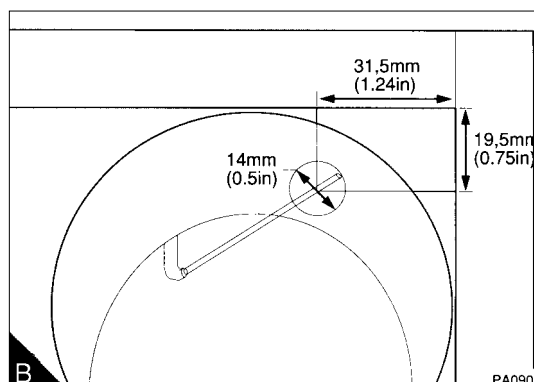
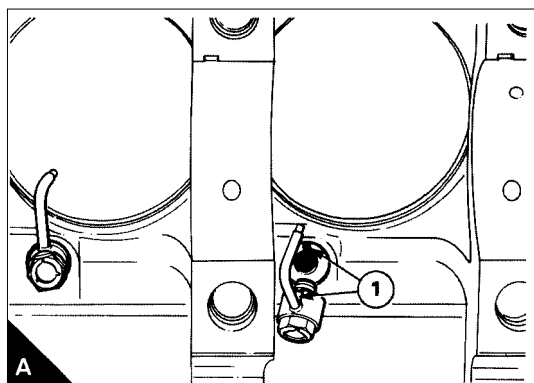

TO CHECK THE JET ALIGNMENT

Insert a 1.70mm (0.067in) diameter rod, of suitable length, into the jet. If a suitable rod is not available, reduce the end of a thicker rod to 1.70mm (0.067in) diameter for a length of 16.00mm (0.630in). When the rod is inserted into the jet it must extend out of the top of the cylinder within the area shown in (B).

- Fit the lubricating oil sump.
- After the engine has been installed, fill the lubricating oil sump to the correct level with an approved oil. Fill the cooling system.

TO INSPECT

Check the crankshaft for wear and other damage. The maximum permissible wear and ovality on the crankshaft journals and crank pins is 0.04 mm (0.0016 in).

The main journals and the crank pins of standard size crankshafts can be machined to 0.25 mm (0.010 in), 0.50 mm (0.020 in) or 0.75 mm (0.030 in) undersize on diameter. Special undersize bearings are available.

The seal location area of the rear flange can be machined to remove the wear marks, if the seal has been used in all positions.

The finished sizes for crankshaft journals (A) which have been ground undersize are given in the table below :

Item	0.25 mm (0.010 in)	0.51 mm (0.020 in)	0.76 mm (0.030 in)
1	75.905/75.926 mm (2.9884/2.9892 in)	75.651/75.672 mm (2.9784/2.9792 in)	75.397/75.418 mm (2.9684/2.9692 in)
2	63.216/63.236 mm (2.4888/2.4896 in)	62.962/62.982 mm (2.4788/2.4796 in)	62.708/62.728 mm (2.4688/2.4696 in)
3	39.47 mm (1.554 in) maximum	—	—
4	37.82 mm (1.489 in) maximum	—	—
5	44.68 mm (1.759 in) maximum	—	—
6	40.55 mm (1.596 in) maximum	—	—
7	133.17 mm (5.243 in) minimum	—	—
8	Do not machine this diameter	—	—
9	3.68/3.96 mm (0.145/0.156 in)	—	—

12

05

19

Surface finish for journals, crank pins and fillet radii must be 0.4 microns (16 micro inches).
Surface finish for seal area of crankshaft palm must be 0.4/1.1 microns (16/43 micro inches).

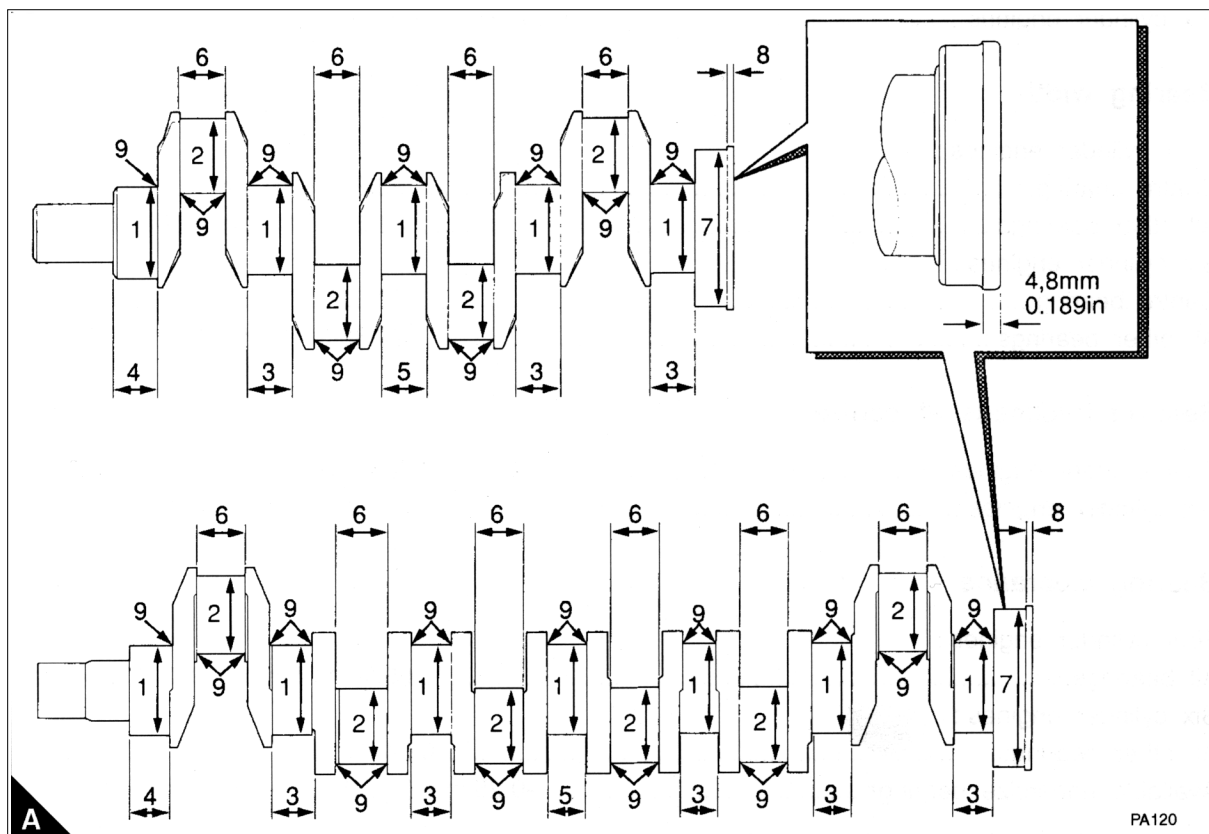

IDLER GEAR AND HUB FOR THE BENDIX COMPRESSOR

The latest compressor is made by Bendix and is driven directly from the engine timing case and does not have an auxiliary drive assembly. The engine idler gear (A12) drives the compressor gear (A4) through a separate idler gear (A11/B4) fitted onto a hub (A9). The hub is fastened to the back of the timing case (A5) by a bracket (A3).

The idler gear is fitted on a needle roller bearing (A7) which is fitted onto the hub. The hub has an O-ring (A1) to prevent oil leakage from the rear of the timing case. The roller bearing and the idler gear are retained on the hub by a plate (A10) Which is fastened to the idler hub.

TO REMOVE AND TO FIT

To remove

- Set the piston of number 1 cylinder to TDC, operation 15-08-2.
- Remove the timing case cover (A6), operation 15-06-1.

⚠ Do not rotate the engine crankshaft or the compressor crankshaft if the idler gear is removed.

If either of the crankshafts are moved, the compressor must be timed to the engine.

- Release the three setscrews (A8). Remove the plate (A10) which retains the idler gear (A11). Remove the gear and the needle roller bearing (A7) from the idler hub (A9).
- Remove the three cap screws (B3) which fasten the idler hub to the bracket (B2) at the rear of the timing case (B1). Remove the idler gear hub.
- Remove and discard the O-ring (A1).
- Inspect the idler gear, needle roller bearing and idler gear hub for wear and other damage and, if necessary, renew them.

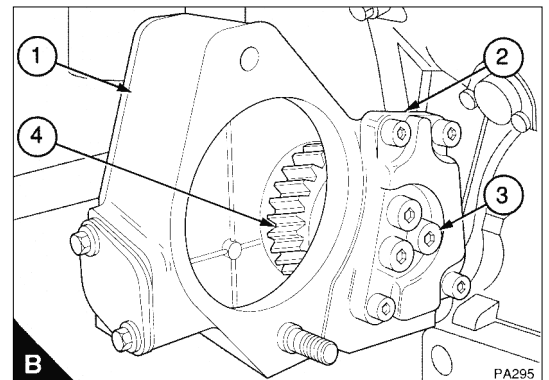
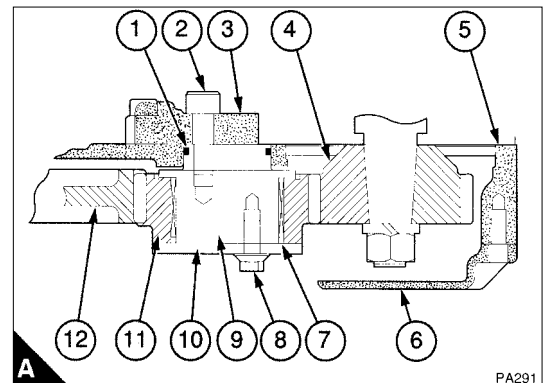

- Remove the rear oil seal assembly and the crankshaft.
- Remove the piston cooling jets, or remove the capscrews and spacers if jets are not fitted

To assemble

- Clean thoroughly the new cylinder block. Ensure that all the oil passages are clean and free from debris.
- Remove the screw plugs from the old cylinder block and clean the threads. Seal the threads with POWERPART Threadseal, or a similar sealant, and fit the screw plugs into the new cylinder block.
- Fit the piston cooling jets, or the spacers and capscrews where jets are not fitted.
- Fit the crankshaft and the rear oil seal assembly.
- Fit the flywheel housing and the flywheel.
- Fit the tappets and the camshaft.
- Fit the lubricating oil pump and the pressure relief valve, or fit the balancer unit.
- Fit the timing case and the timing gears.
- Fit the cylinder head assembly.
- Fit the starter motor.
- Fit the fuel lift pump.
- If necessary, fit the turbocharger.
- Fit the lubricating oil filter assembly and the lubricating oil sump.
- If necessary, fit the lubricating oil cooler.
- Fit the fuel filter, the atomisers and the fuel injection pump.
- If necessary, fit the compressor or the exhauster.
- Fit the fan, the fan drive and the water pump.
- Fit the alternator and its mounting brackets and the alternator drive belts.
- Install the engine into the vehicle or machine.
- Fill the cooling system.
- Fill the lubricating oil sump to the correct level with an approved lubricating oil.
- Eliminate air from the fuel system.

TO INSPECT

- Clean the passages for the coolant and for the oil.
- Check the cylinder block for cracks and for other damage.
- The top face of the cylinder block must not be machined as this will affect the liner flange depth and the piston height above the top face of the cylinder block.
- Check the camshaft bush for wear. If the bush is to be renewed, use a suitable adaptor to press it out of the bore. Ensure that the lubricating oil hole in the new bush will be towards the front of the engine, when fitted. Press in the bush with the oil hole on the same side and aligned with the oil hole in the block until the front end of the bush is aligned with the face of the recess.

- If the timing is more than 2 1/2° out of position, the timing gears are probably not in correct mesh.

Note :

One tooth on the camshaft gear is equivalent to 23 mm (0.9 in) at the circumference of a pulley of 203 mm (8 in) diameter. If a large damper is fitted, one tooth on the camshaft gear is equivalent to 35 mm (1.4 in) at the circumference of a damper of 310 mm (12.2 in) diameter, or 37 mm (1.5 in) at the circumference of a damper of 327 mm (12.8 in) diameter.

- Rotate the crankshaft, clockwise from the front, until the inlet valve of the rear cylinder is fully open. Set the valve tip clearance of the inlet valve of number 1 cylinder to 0.20 mm (0.008 in).
- Fit the rocker cover, operation 15-03-1.
- Remove the temporary pointer from the timing case and the timing mark from the pulley or damper.

12

08

4

TO CHECK THE TIMING OF THE FUEL INJECTION PUMP

Special tools :

Timing pin PD.246, Lucas and Stanadyne fuel injection pumps

- ⚠ **Do not remove the nut (A2) which retains the hub (A4) to the shaft of the fuel injection pump. The hub is fitted permanently to the shaft. If the hub is moved, it will be necessary for a fuel injection pump specialist to correctly position the hub on the shaft with special test equipment available to Perkins distributors.**

- Set the piston of number 1 cylinder to TDC on the compression stroke, operation 15-08-2.
- Remove the gear cover from the cover of the timing case. For gear driven coolant pumps : Remove the coolant pump, operation 15-11-2.

Note :

On the latest engines with belt driven coolant pumps, four tamper proof fasteners retain the fuel pump gear. Special tools and personnel with the correct training are necessary to remove these fasteners, refer to your nearest Perkins distributor.

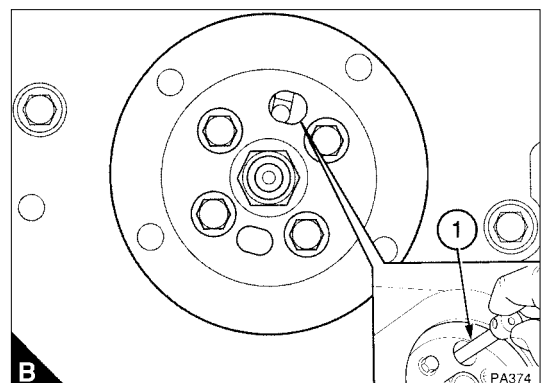
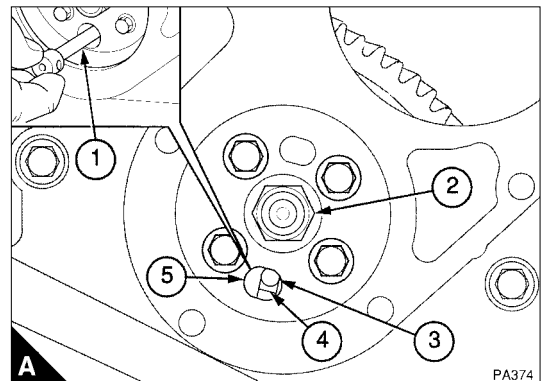

- Insert the timing pin (A1) through the hole (A5) in the fuel pump gear and the slot of the hub (A4).

Push the pin fully into the hole (A3) in the body of the fuel pump. If the pin can be fully inserted then the pump timing is correct. There should be no resistance when the pin is inserted.

⚠ Do not use excessive torque.

- Hold the spacer in position and engage the setscrew fully into the threads in the pin.
- Put the spacer into position centrally over the pin and tighten the nut onto the spacer. Continue to tighten the nut and pull the pin through the spacer. Withdraw the pin enough to pull the pin out of the bearing cap with pliers.
- Put a suitable adaptor on the small diameter of the idler shaft and press the idler shaft out of the bearing cap.

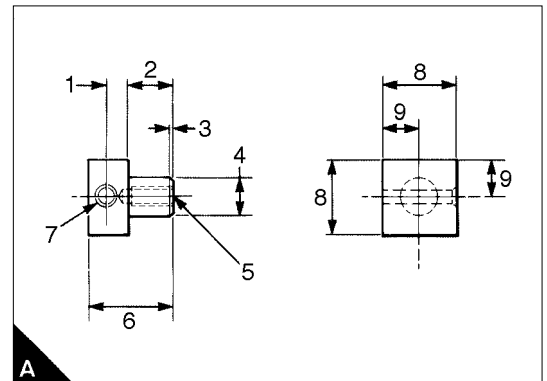

Optional method to remove the idler shaft

This method to remove the pin from the idler shaft must only be used if the pin cannot be removed by the earlier method.

- Make a drill guide (A) to the dimensions given below :

A1	8.3 mm (0.327 in)
A2	20.0 mm (0.984 in)
A3	1.0 mm (0.039 in)
A4	16.1/16.4 mm (0.633/0.646 in)
A5	6.9 x 22 mm (0.272 x 0.866 in) diameter hole for 5/16–24 UNF x 18 mm thread
A6	36.0 mm (1.42 in)
A7	6.5/6.6 mm (0.256/0.260 in) diameter hole, countersink 9.0 mm x 90° included
A8	31.75 mm (1.250 in)
A9	15.9 mm (0.626 in)

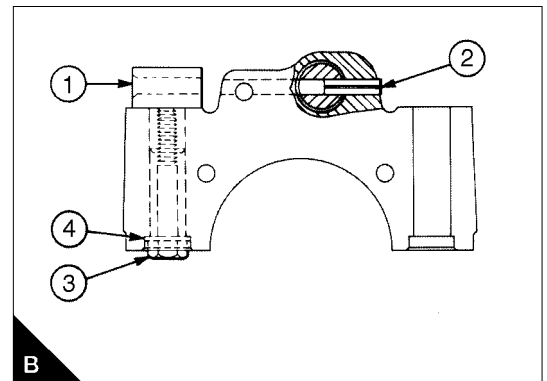

- Put the drill guide (B1) into position in the setscrew hole on the opposite side of the bearing cap to the pin (B2). Ensure that the countersink in the guide faces to the outside and that the edge of the guide is aligned with the front edge of the bearing cap. Use a 5/16 UNF setscrew (B3) and a plain washer (B4) to retain the guide in position.
- Drill a 6.35 mm (0.25 in) diameter hole in the bearing cap 47.0 mm (1.85 in) deep.
- Remove the drill and the drill guide.
- Insert a suitable drift into the hole in the bearing cap and drive out the pin.
- Put a suitable adaptor on the small diameter of the idler shaft and press the idler shaft out of the bearing cap.

To fit the idler shaft

- Check that the new idler shaft, part number 3271H002 or 3271H004 and the hole for the idler shaft in the bearing cap are clean and free from oil or grease. Remove any rough edges from the hole of the bearing cap.

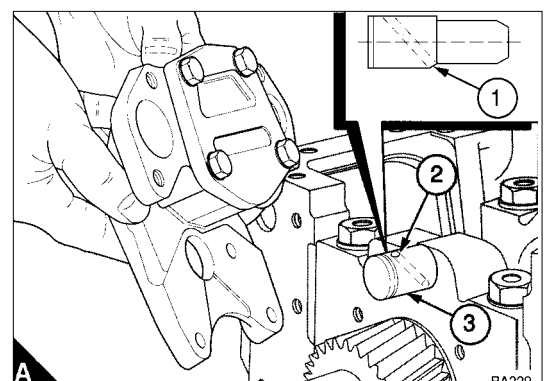

- Ensure the filter head is clean. Push the new canister (s) fully into the filter head (A3).
- Support the canister (s), fit the gland ring and rotate it to the right to fasten the canister to the filter head.
- If it was removed, fit the nylon insert used to lower the level of the fuel in the filter canister and fasten the cap.
- Eliminate the air from the fuel filter, operation (s) 15–10–15.

ATOMISERS

ATOMISER FAULT

Regular maintenance of the atomisers is not necessary. The atomiser nozzles should be renewed and not cleaned, and renewed only if an atomiser fault occurs. The major problems that may indicate that new nozzles are needed are listed below :

Engine will not start or is difficult to start
 Not enough power
 Engine misfires or runs erratically
 High fuel consumption
 Black exhaust smoke
 Engine knocks or vibration
 Excessive engine temperature

- ⚠ • **If your skin comes into contact with highpressure fuel, obtain medical assistance immediately.**
- **Keep away from moving parts during engine operation. Some moving parts cannot be seen clearly while the engine runs.**

In order to find which atomiser is defective, operate the engine at a fast idle speed. Loosen and tighten the union nut of the high-pressure fuel pipe at each atomiser. Do not loosen the union nut more than half a turn. When the union nut of the defective atomiser is loosened, there is little or no effect on the engine speed.

12

10

16

- Loosen the union nut at the outlet connection of the low pressure fuel leak off pipe which is on top of the governor housing of the fuel injection pump. Operate the priming lever of the fuel lift pump until fuel, free of air, comes from the connection. Tighten the union nut.

⚠ Do not tighten the union nuts of the high-pressure pipes more than the recommended torque tension. If there is a leakage from the union nut, ensure that the pipe is correctly aligned with the atomiser inlet. Do not tighten the atomiser union nut more, as this can cause a restriction at the end of the pipe. This can affect the fuel delivery.

- Loosen the high-pressure connections at two of the atomisers (D1).

⚠ Damage to the fuel injection pump, battery and starter motor can occur if the starter motor is used excessively to eliminate air from the fuel system.

- Put the electrical system switch (user's handbook, page 3.03/A) to the "ON" position. Ensure that the manual stop control, if one is fitted, is in the "run" position. Operate the starter motor until fuel, free from air, comes from the pipe connections. Tighten the high-pressure pipe connections to 22 N·m (16 lbf·ft) 2.2 kgf·m. Return the switch to the "OFF" position.
- The engine is now ready to start.

⚠ Operate the engine at low idle speed for a minimum of five minutes immediately after air has been removed from the fuel system. This will ensure that the pump is completely free of air and prevent any damage to the pumps internal parts by metal to metal contact.

If the engine runs correctly for a short time and then stops or runs roughly, check for air in the fuel system. If there is air in the fuel system, there is probably a leakage in the low pressure system.

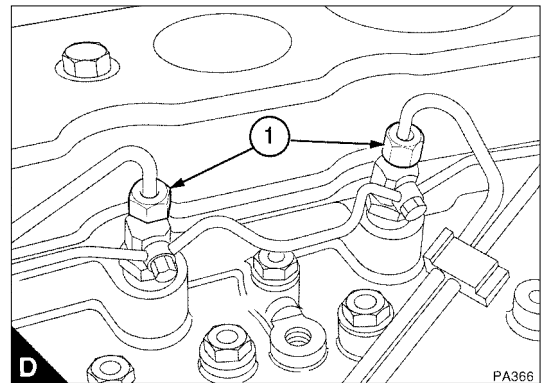
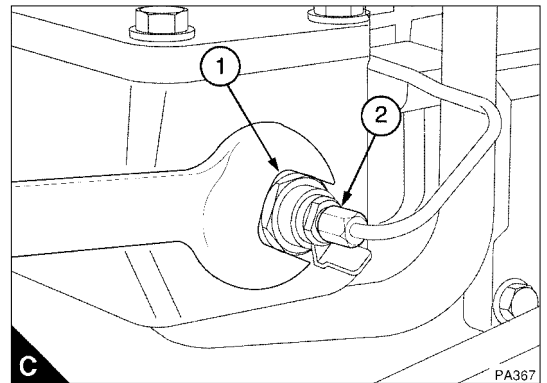

DATA AND DIMENSIONS

Note :

This information is given as a guide for personnel engaged on engine overhauls. The dimensions which are shown are those which are mainly used in the factory. The information applies to all engines, unless an engine type code is shown.

LUBRICATING OIL COOLER

TO REMOVE AND TO FIT—PRESSED STEEL COVER TYPE

To remove

- Drain the cooling system, refer to the User's Handbook, page 4.06.

 **The engine oil may be hot, allow the engine temperature to cool down before the oil pipes are released.**

 **Do not remove both of the oil pipes together.**

- Put a drip tray under the oil cooler and remove the lubricating oil pipes from the oil cooler. Do not remove both of the oil pipes together. Remove one of the pipes, then fit the flanges (A4) and nuts (A5) onto the studs again, before the other pipe is removed. This will ensure that the element (A6) is fastened to the cover when the assembly is removed.
- Discard the O-rings (A1).
- Release the fasteners (A2) from the cover of the oil cooler and remove the oil cooler assembly (A3).

12

11

8

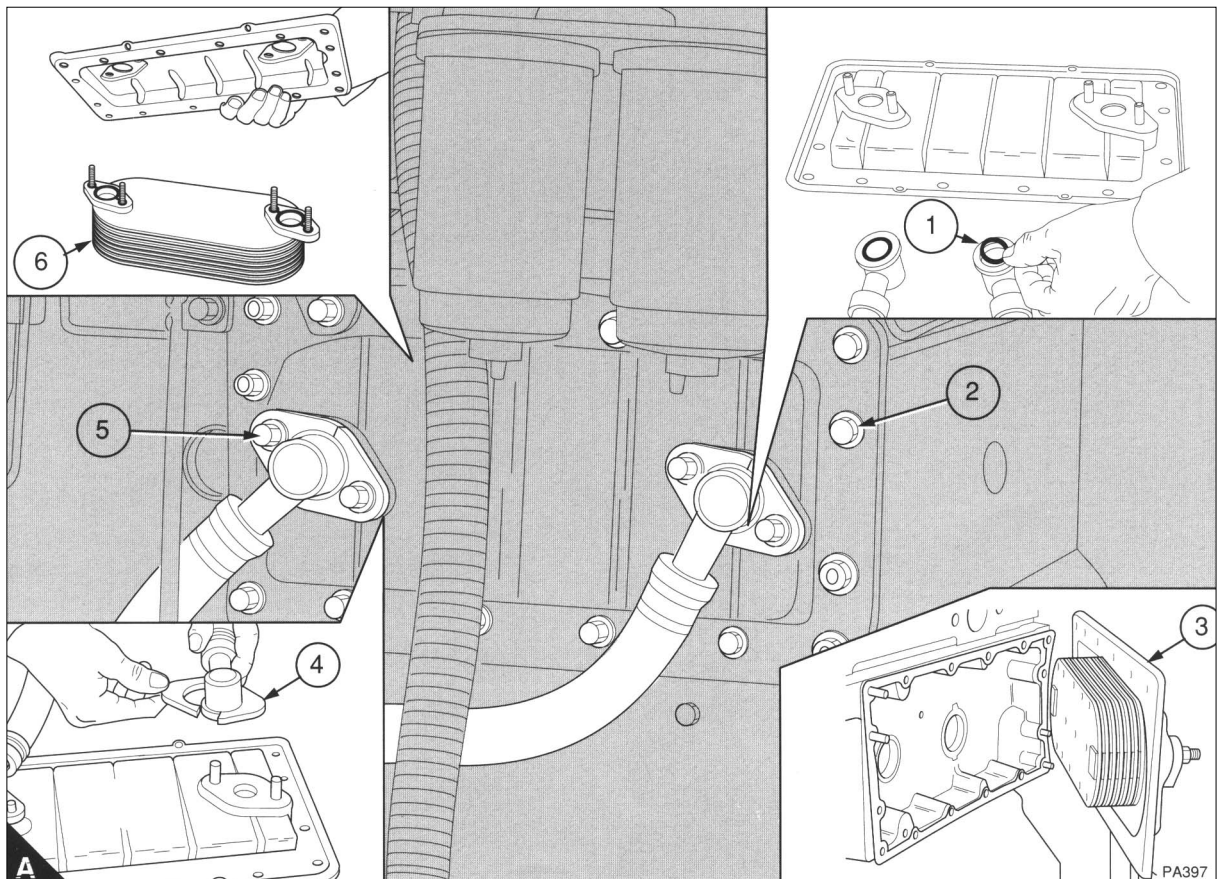

RING GEAR

TO REMOVE AND TO FIT

To remove

 For this operation eye protection must be used.

Before the ring gear is removed, check the position of the chamfer on the teeth.

To remove the ring gear use a hammer and a chisel to break the ring. Ensure that the flywheel is not damaged during this operation.

To fit

The ring gear is heated onto the flywheel. When a new gear is to be fitted, ensure that it is not heated to more than 250°C (480°F). Ensure that the chamfer on the teeth of the gear is in the correct direction.

12

12

2

FLYWHEEL HOUSING

TO REMOVE AND TO FIT

To remove

- Remove the starter, and the flywheel.
- Release the housing capscrews and with a soft face hammer, tap the housing carefully to remove it from the dowels.

To fit

- Ensure that the rear face of the cylinder block and the faces of the housing are clean and free from damage. Ensure that the location dowels are fitted correctly. If a felt seal is fitted to the rear flange of the sump, renew the seal.
- Fit the housing onto the dowels and tighten lightly the capscrews.
- Check the housing concentricity with a dial test indicator (A). If any adjustment is necessary, it must be made on the housing and the concentricity checked again.
- Tighten the capscrews to the specified torque
- Check the housing alignment (B). Any necessary adjustment must be made on the housing and not on the cylinder block.
- Fit the flywheel, and the starter motor.

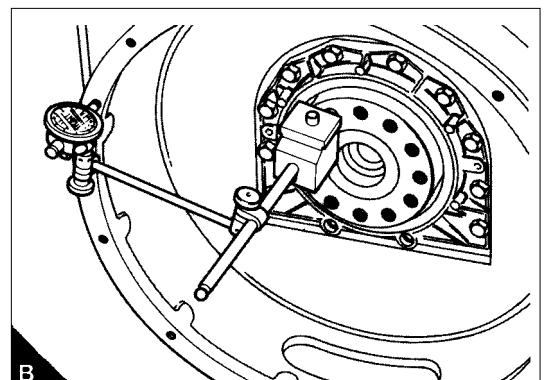
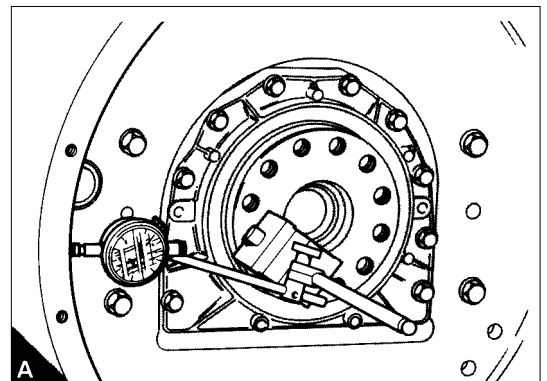

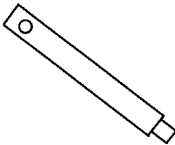
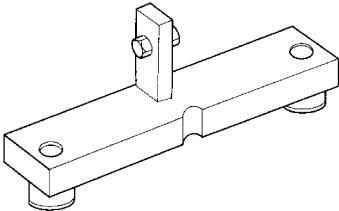
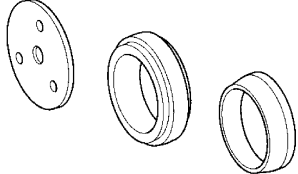
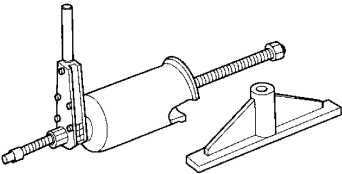
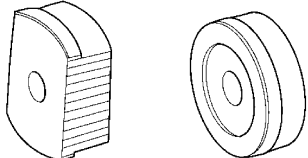
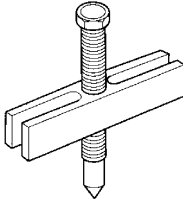
Number	Description	Illustration
PD.246	Timing pin for Lucas and Stanadyne fuel injection pumps. Part number 27610033	
PD.41D	Gauge for piston height, valve depth and cylinder liner flange ; for use with PD.208. Part number 21825496	
PD.145D	Replacer tool for crankshaft rear seal. Part number 21825540	
PD.150B	Remover/replacer for cylinder liner (main tool). Part number 21825543	
PD.150B-17A	Adaptors for use with PD.150B. Part number 21825563	
PD.155C	Basic puller for camshaft gear. Part number 21825565	

POWERPART Metal repair putty

Designed for external repair of metal and plastic. Part number 21820126.

POWERPART Pipe sealant and sealant primer

To retain and seal pipe connections with coarse threads. Pressure systems can be used immediately. Part number 21820122.

POWERPART Radiator stop leak

For the repair of radiator leaks. Part number 21820127.

POWERPART Red rubber grease

Provides lubrication for the fitting of "O" rings. Part number 21820221.

POWERPART Retainer (high strength)

To retain components that have an interference fit. Part number 21820638.

POWERPART Retainer (oil tolerant)

To retain components that have an interference fit, but is in contact with oil. Part number 21820603.

POWERPART Safety cleaner

General cleaner in an aerosol container. Part number 21820128.

POWERPART Silicone adhesive

An RTV silicone adhesive for application where low pressure tests occur before the adhesive sets. Used for sealing flange where oil resistance is needed and movement of the joint occurs. Part number 21826038.

POWERPART Silicone RTV sealing and jointing compound

Silicone rubber sealant that prevents leakage through gaps. Part number 1861108.

POWERPART Stud and bearing lock

To provide a heavy duty seal to components that have a light interference fit. Part number 21820119 or 21820120.

POWERPART Threadlock and nutlock

To retain small fasteners where easy removal is necessary. Part number 21820117 or 21820118.

POWERPART Universal jointing compound

Universal jointing compound that seals joints. Part number 1861117.

The finished sizes for crankshaft journals (A) which have been ground undersize are given in the table below :

Item	0.25 mm (0.010 in)	0.51 mm (0.020 in)	0.76 mm (0.030 in)
1	75.909 / 75.930 mm (2.9884 / 2.9892 in)	75.649 / 75.670 mm (2.9784 / 2.9792 in)	75.399 / 75.420 mm (2.9684 / 2.9692 in)
2	63.220 / 63.240 mm (2.488 / 2.4896 in)	62.960 / 62.982 mm (2.4788 / 2.4796 in)	62.708 / 62.728 mm (2.4688 / 2.4696 in)
3	39.47 mm (1.554 in) maximum	—	—
4	37.44 mm (1.474 in) maximum	—	—
5	44.68 mm (1.759 in) maximum	—	—
6	40.55 mm (1.596 in) maximum	—	—
7	Do not machine	—	—
8	Do not machine	—	—
9	3.68/3.96 mm (0.1448/0.1452 in)	—	—

13

02

10

Surface finish for journals, crank pins and fillet radii must be 0,4 microns (16 micro inches). Surface finish for the seal area of the crankshaft palm must be 0,4/1,1 microns (16/43 micro inches).

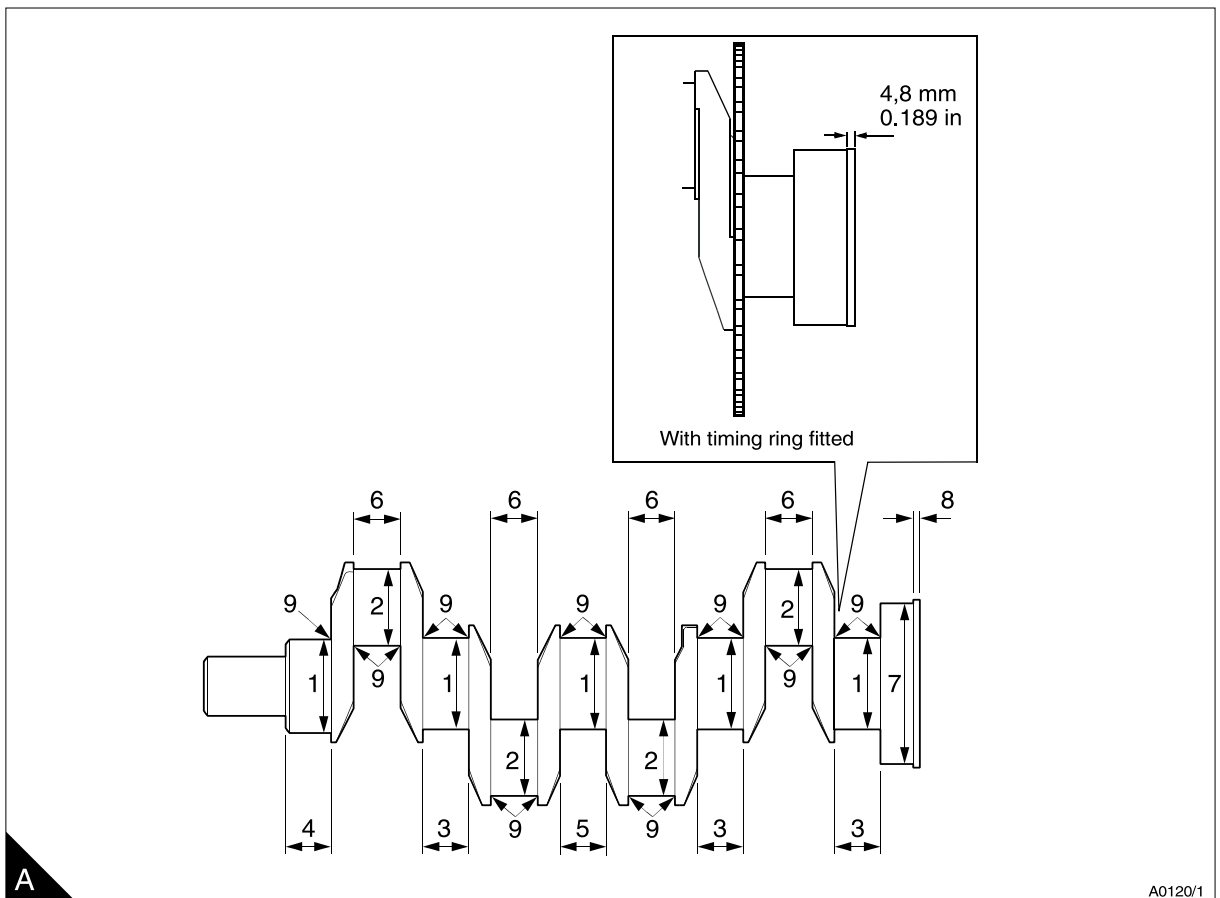

A

A0120/1

STANDARD TORQUE VALUES

Most of the torque values on the engine are standard. Special torque values are listed in the separate special torque tables. The standard torque values listed in the tables below can be used when a special torque is not necessary.

The torque values below apply to components lubricated with a little clean engine oil before they are fitted.

Standard torques for setscrews and nuts

Thread size	Torque		
	Nm	lbf ft	kgf m
M6 x 1,00	9	7	0,9
M8 x 1,25	22	16	2,2
M10 x 1,50	44	32	4,5
M12 x 1,25	78	58	8,0
M14 x 2,00	124	92	13,0
M16 x 2,00	190	140	19,3

Standard torques for studs (metal end)

Thread size	Torque		
	Nm	lbf ft	kgf m
M6 x 1,00	5	4	4
M8 x 1,25	11	8	1.1
M10 x 1,50	18	13	1.8
M12 x 1,75	25	18	2.5

Standard torques for pipe unions, plugs, and adaptors

Thread size	Torque		
	Nm	lbf ft	kgf m
1/8 PTF	9.5	7	0.9
1/8 PTF	17	12	1.7
3/8 & 1/2 PTF	30	22	3.0
3/4 PTF	45	33	4.6

VALVE TIP CLEARANCES

To check and to adjust

Operation 3-7

The valve tip clearances are checked between the top of the valve stem and the rocker lever (A), with the engine cold. The correct clearance for intake valves is 0,20 mm (0.008 in) and 0,45 mm (0.018 in) for exhaust valves. The valve positions are shown at (B).

The sequence of valves from number 1 cylinder is shown in the table below.

Note :

Number 1 cylinder is the furthest cylinder from the flywheel end of the engine.

- 1 Rotate the crankshaft in the normal direction of rotation until the intake valve (B7) of number 4 cylinder has just opened and the exhaust valve (B8) of the same cylinder has not closed completely. Check the clearances of the valves (B1 and B2) of number 1 cylinder and adjust them, if necessary.

Note :

The correct torque for the locknut on the adjusting screws is 27 Nm (20 lbf ft) 2,8 kgf m.

- 2 Set the valves (B3 and B4) of number 2 cylinder as indicated above for number 4 cylinder. Then check / adjust the clearances of the valves (B5 and B6) of number 3 cylinder.
- 3 Set the valves (B1 and B2) of number 1 cylinder. Then check / adjust the clearances of the valves (B7 and B8) of number 4 cylinder.
- 4 Set the valves (B5 and B6) of number 3 cylinder. Then check / adjust the clearances of the valves (B3 and B4) of number 2 cylinder.

Note :

After the valve tip clearances have been adjusted, lubricate the rocker assembly with clean engine oil. Apply particular attention to the rocker shaft bearing surfaces, valve tips, push rod sockets and the push rods so that the oil will drain to lubricate the cam followers.

Cylinder and Valve number	1		2		3		4	
	1	2	3	4	5	6	7	8
Valve I = Intake E = Exhaust	I	E	I	E	I	E	I	E

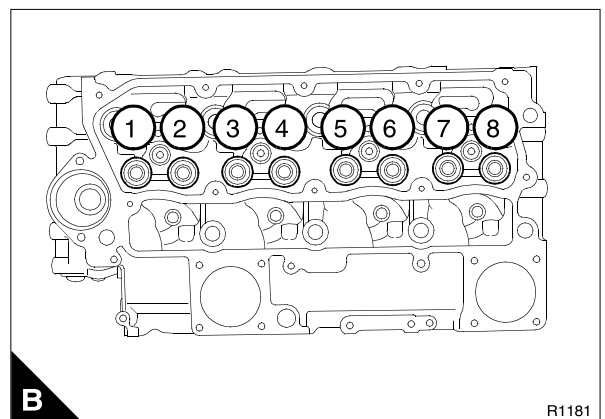
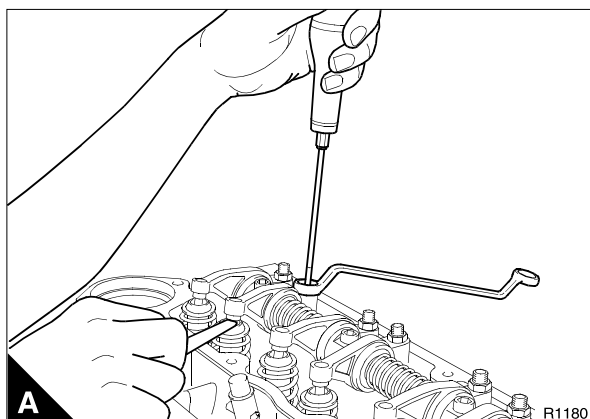

To fit

Operation 3-13

Special requirements

Special tools			
Description	Part number	Description	Part number
Gauge, valve depth	21825496	Dial gauge for use with 21825496	21825617

- 1 Ensure that the heads of the valves and the bottom face of the cylinder head are clean.
- 2 Put the valve depth gauge on the face of the cylinder head and zero the dial gauge.
- 3 Carefully put the valve depth gauge in position over the head of each valve (A) and make a note of the measurement. The maximum depth, in service, is given in the relevant Data and dimensions for the "Intake and exhaust valves" on page 13.
- 4 If a valve is below the depth limit, check the valve depth with a new valve in position. If the valve depth is still below the limit the valve seat insert must be renewed, see Operation 3-19.
- 5 Check the valves for cracks. Check the stems of the valves for wear and for correct fit in their valve guides.

⚠ • Valves must not be lapped, as the special heat resistant layer on the face of the valve will be destroyed.

• If inlet valves are badly worn or damaged they must be replaced.

- 6 Check that the seat faces of the valves are not badly burnt or damaged. Seat faces of valves which are damaged can be ground on a special machine.

When new valves are fitted, the valve depths must be checked after the valve springs are fitted.

- 7 Check that the load on the valve springs is correct at their fitted length, refer to the relevant Data and dimensions for the "Valve guides and valve springs" on page 16. Fit new valve springs at every complete engine overhaul.

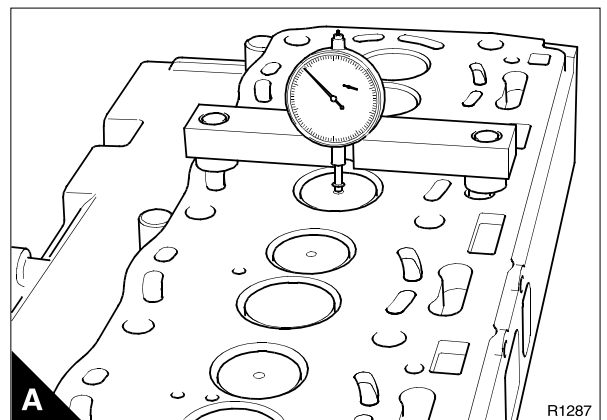

13

03

16

In service, a partially finished small-end bush is available, which can be fitted to the original connecting rod and machined to obtain the correct length grade, see Operation 4-14. Specialist equipment and personnel with the correct training are needed to machine the partially finished small-end bush. Connecting rod kits are also available with the small end bush fitted and machined to obtain the correct connecting rod grade. For further information refer to your nearest Perkins Dealer/Distributor.

Notes :

- If the crankshaft or the cylinder block is to be renewed, it may be necessary to change the grade of the connecting rods, see Operation 4-11. This will occur if the correct piston height above the cylinder block face cannot be maintained with the original connecting rod assemblies, see Operation 4-6.
- Always use the engine identification number to order new parts.

The connecting rod is a one-piece forging that is fractured hydraulically to split the big end cap from the connecting rod. This process produces rough but accurately matched surfaces (C1).

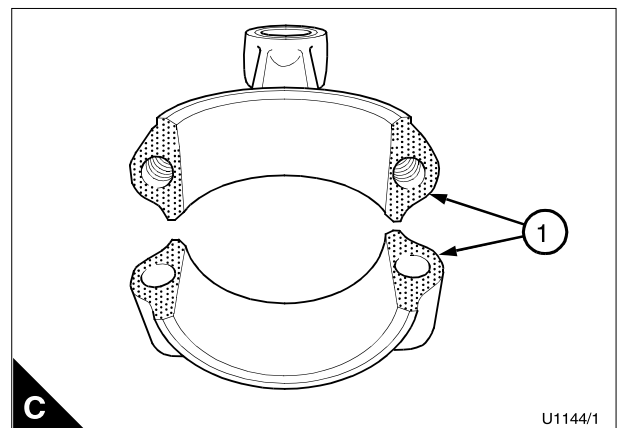
**13****04****2**

PISTON AND PISTON RINGS

To inspect

Operation 4-12

- 1 Check the piston for wear and other damage.
- 2 Check that the piston rings are free to move in their grooves and that the rings are not broken.
- 3 Remove the piston rings, see Operation 4-7, and clean the piston ring grooves and the piston rings.

Note :

Engine models RG, RH, RJ, and RK, have pistons that have a tapered top groove and the piston ring is wedge shaped. The top piston ring clearance cannot be checked by this method.

- 4 Fit new piston rings in the grooves and check for wear of the grooves with feeler gauges (A). Compare the piston ring clearance in the groove to that given for new components in the relevant Data and dimensions for the "Pistons and piston cooling jets" on page 17, and renew the piston if necessary.
- 5 Clean all carbon from the top of the cylinder bore. Fit each piston ring in the top part of the cylinder bore and measure the ring gap with feeler gauges (B). The coil spring must be removed from the oil control ring when the gap of this piston ring is measured.
The piston ring gaps for new components are given in the relevant Data and dimensions for the "Piston rings" on page 17.

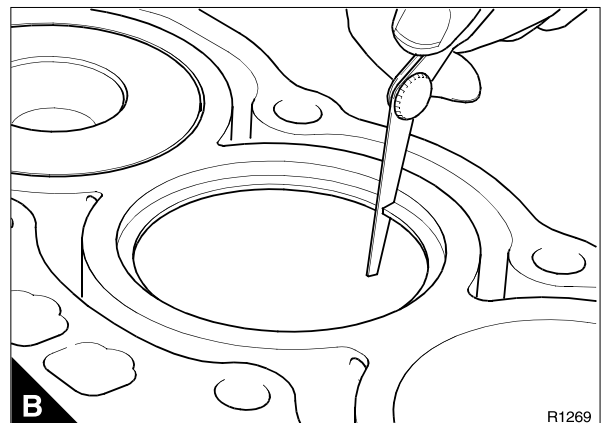
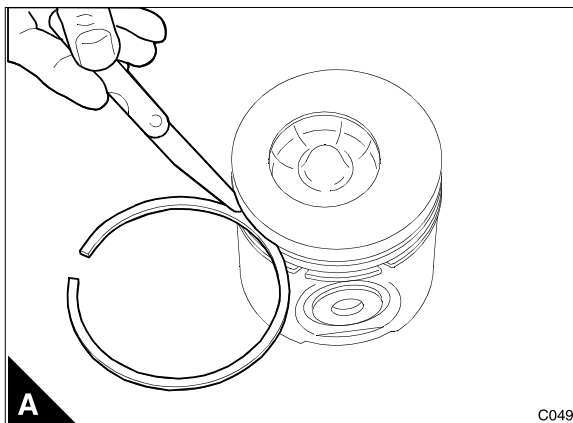

13

04

12

Alignment tool

The alignment tool (F) must be manufactured locally to the following specifications :

- 1 Outer surface (F1) to be knurled
- 2 Remove all sharp edges
- 3 To be made from material EN 32, harden 0,5 mm deep.

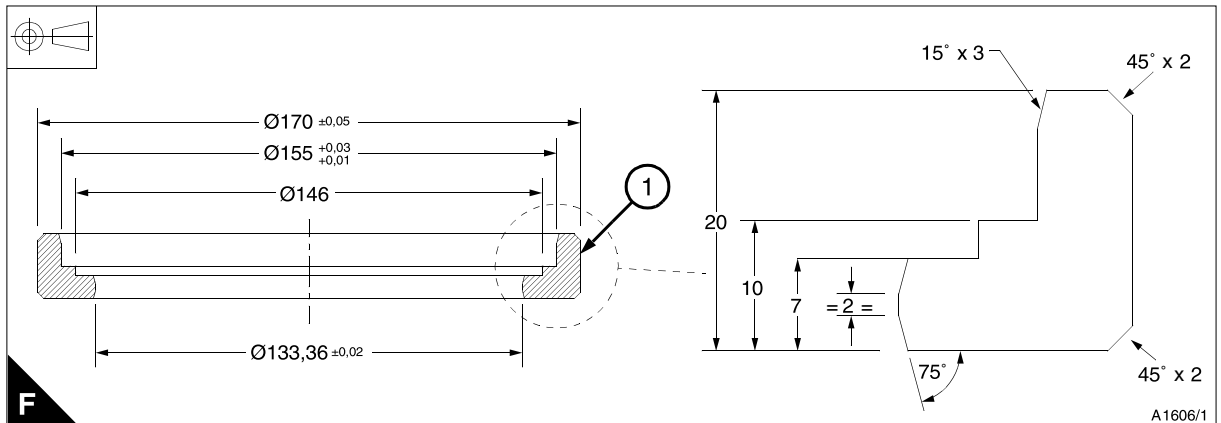
**Note :**

All dimensions are in millimetres.

13

05

6

F

A1606/1

To inspect**Operation 5-12**

Check the crankshaft for wear and other damage. The maximum permissible wear and ovality on the crankshaft journals and crank pins is 0,04 mm (0.0016 in).

The main journals and the crank pins of standard size crankshafts can be machined to 0,25 mm (0.010 in), 0,50 mm (0.020 in) or 0,75 mm (0.030 in) undersize on diameter, see "Crankshaft overhaul" on page 19.

Special undersize bearings are available.

13*05*

16

TIMING CASE COVER

To remove

Operation 6-1

Note :

- To assist with access to the timing case cover, the fan drive can be removed, see Operation 12-9.
- The timing case cover can be removed with the crankshaft pulley fitted.

- 1 Remove the coolant pump, see Operation 12-4.
- 2 Remove the setscrews and the cover (A1), together with the joint.
- 3 Remove the joint from the cover and discard the joint.

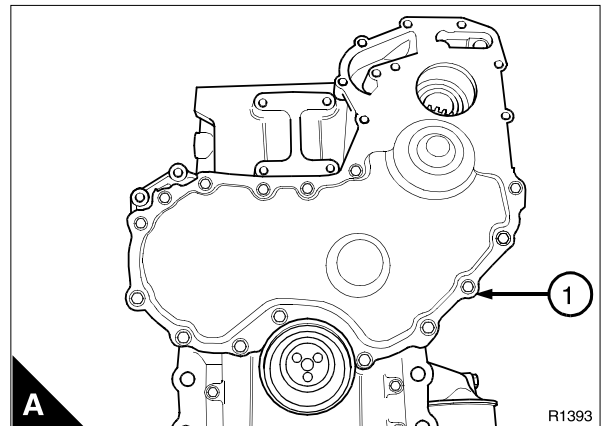

13

06

2

- 3 Lubricate the hub with clean lubricating engine oil and fit the gear to the hub. Rotate the hub in the gear to align the oil way to the top.
- 4 Fit the hub assembly (C1) over the front oil seal housing (C2) and into mesh with crankshaft gear and camshaft gear. Check that the hole (D1) is towards the cylinder head.
- 5 Align the plate (E2) to the three holes in the hub. Fit the setscrew (E3).
- 6 With the hub assembly fitted, tighten evenly the three setscrews (E3) to 44 Nm (32 lbf) 4,5 kgf m.
- 7 Check the end float (E1) and back lash, see "Timing case and drive assembly" on page 22.
- 8 Fit the mechanical fuel pump gear, see Operation 6-4, or the electronic fuel pump gear, see Operation 6-6.
- 9 Fit the rocker assembly, see Operation 3-4.

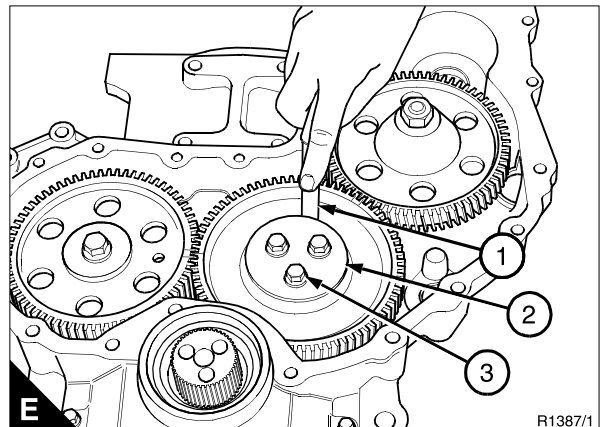
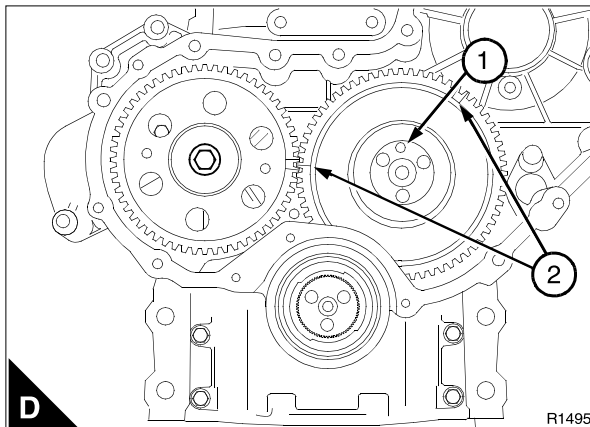
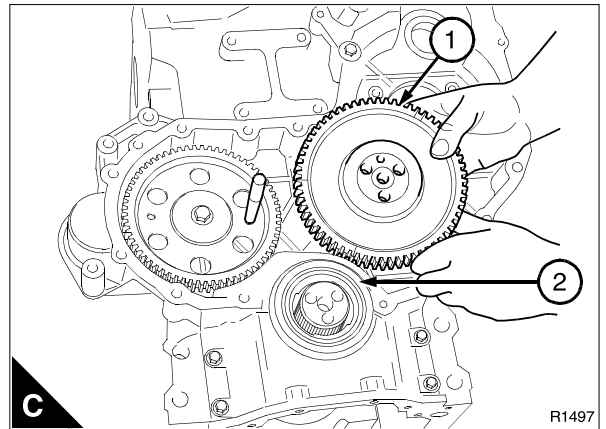

13

06

12

To fit

Operation 6-17

Special requirements

Special tools			
Description	Part number	Description	Part number
Crankshaft timing pin	27610211	POWERPART Retainer	21820608
Camshaft timing pin	27610212		
Fuel pump timing pin	27610032		
Alignment tool	27610216		

Note :

If a new timing case is to be fitted, it may be necessary to fit blanking plugs. Apply POWERPART retainer, part number 21820608, to the blanking plug bore. This plug must be fitted into the timing case before the case is fitted to the engine.

- 1 Clean and check the timing case for damage, renew if necessary.
- 2 Check that the camshaft thrust washer is fitted correctly. Fit the lower timing case joint (A1) onto the cylinder block.
- 3 Fit two temporary studs (A2) to the cylinder block.
- 4 Fit the upper timing case joint (B1) to the timing case (B2).

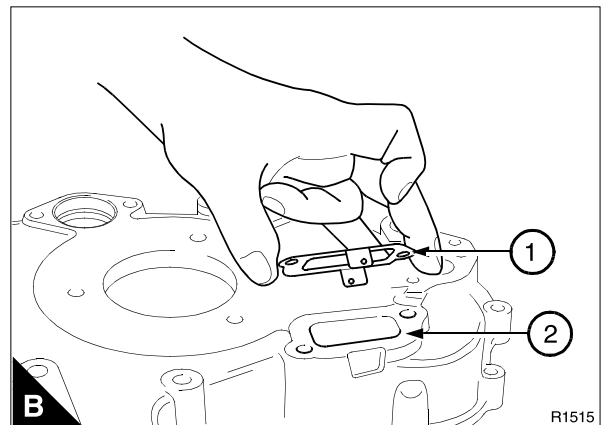
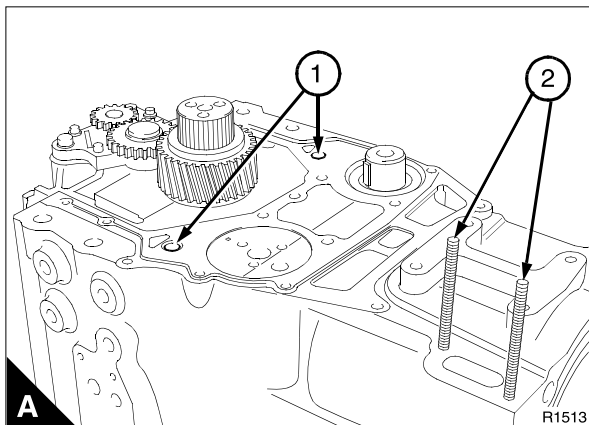
*Continueud*

CLICK HERE TO **DOWNLOAD** THE COMPLETE MANUAL

- Thank you very much for reading the preview of the manual.
- You can download the complete manual from: www.heydownloads.com by clicking the link below



- Please note: If there is no response to CLICKING the link, please download this PDF first and then click on it.

CLICK HERE TO **DOWNLOAD** THE COMPLETE MANUAL

To fit

- 1 Fit the new joint (B4) into the breather pipe housing.
- 2 Push the two fasteners (B2) into the breather pipe assembly.
- 3 Fit a new "O" ring (B3) to the breather pipe assembly and lubricate the "O" ring with clean lubricating engine oil.
- 4 Push the breather pipe assembly into the rocker cover and tighten the fasteners to 9 Nm (7 lbf ft) 0,9 kgf m.
- 5 Fit the breather hose and tighten the clip to 5 Nm (4 lbf ft) 0,5 kgf m.

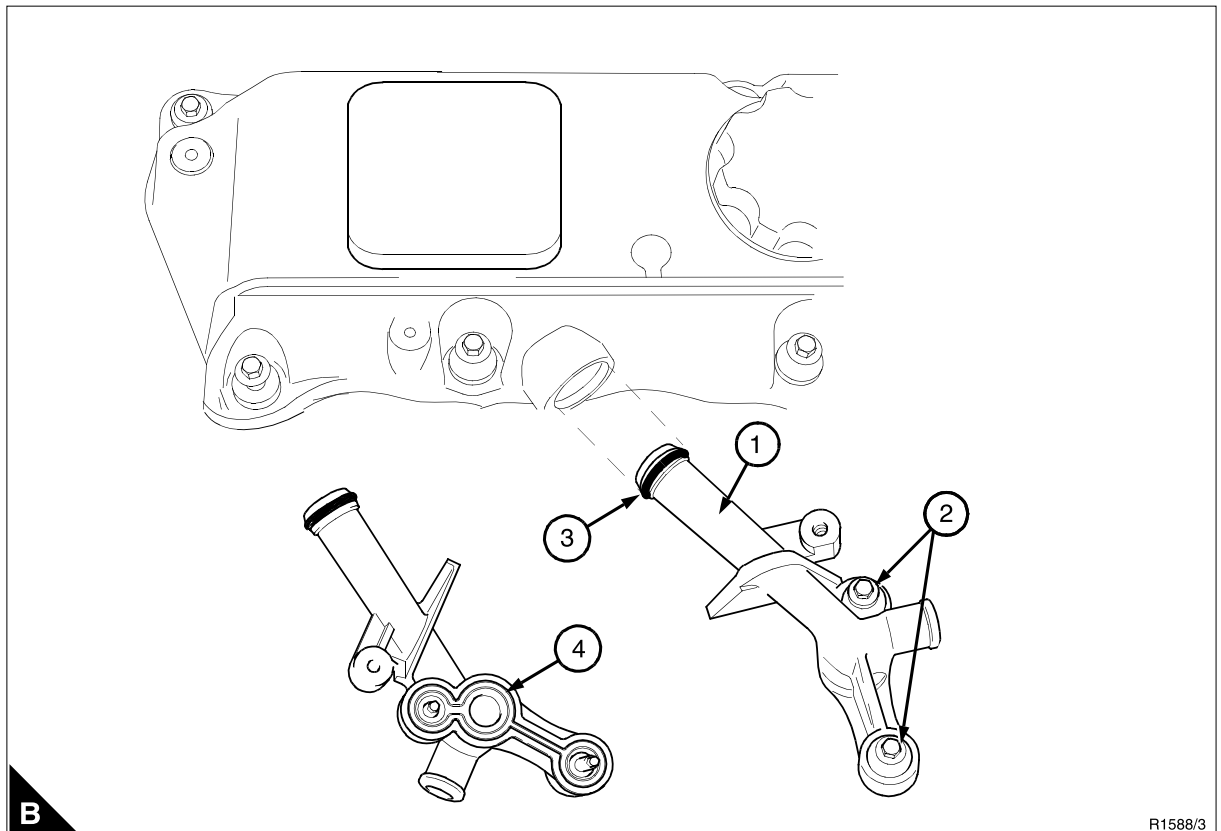
**13**

09

2

SUMP

To remove

Operation 10-4

- ⚠ • Discard the used lubricating oil in a safe place and in accordance with local regulations.
- Before the sump is removed, especially with the cast iron version, ensure that the sump is fully supported before the setscrews are removed.

- 1 Operate the engine until it is warm.
- 2 Stop the engine, remove the sump drain plug (A1) and its 'O' ring, and drain the oil. Where necessary, remove the dipstick and the dipstick tube, see Operation 10-6.
- 3 Provide a support for the sump and remove the setscrews and, if relevant, the two nuts which fasten the sump to the timing case. Lower the sump and remove and discard the joint.
- 4 Wash the sump with an approved cleaning fluid, ensure all the cleaning fluid is removed. Clean the flange face of the sump and of the cylinder block.

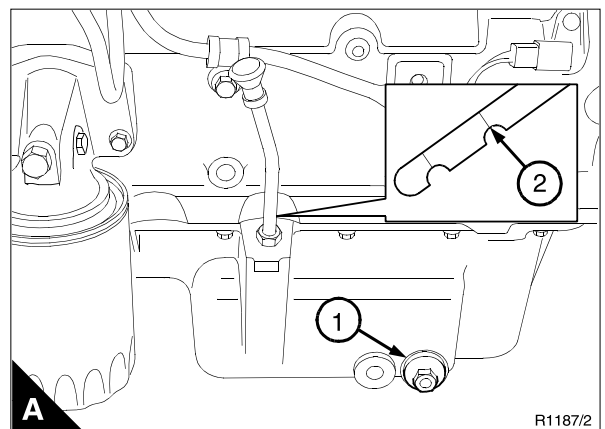

13

10

6

FUEL LIFT PUMP AND FILTER ASSEMBLY

To remove and to fit

Operation 11-5

⚠ Do not allow dirt to enter the fuel system. Before a connection is disconnected, clean thoroughly the area around the connection. After a component has been disconnected, fit a suitable cover to all open connections.

To remove

- 1 Disconnect the fuel pipes from the electric fuel lift pump and filter assembly.
- 2 Drain the electric fuel lift pump and filter assembly, see Operation 11-1.
- 3 Remove the setscrew (A2) and the spacer from the support bracket (A3) for the fuel pipes.
- 4 Remove the setscrews (A1) and rubber washers. Remove the electric fuel lift pump and filter assembly.

To fit

Note :

Ensure that new rubber washers are fitted to the setscrews and the cylinder block before the electric fuel lift pump and filter assembly is fitted.

- 1 Fit the setscrews (A1) and new rubber washers to the fuel lift pump and filter assembly.
- 2 Fit the spacer and the setscrew (A2) to the support bracket (A3) for the fuel pipe.
- 3 Fit the fuel pipes to the fuel lift pump and filter assembly.
- 4 Eliminate any trapped air from the fuel system, see Operation 11-8.
- 5 Operate the engine and check for leakage of fuel and that there is no air in the system.

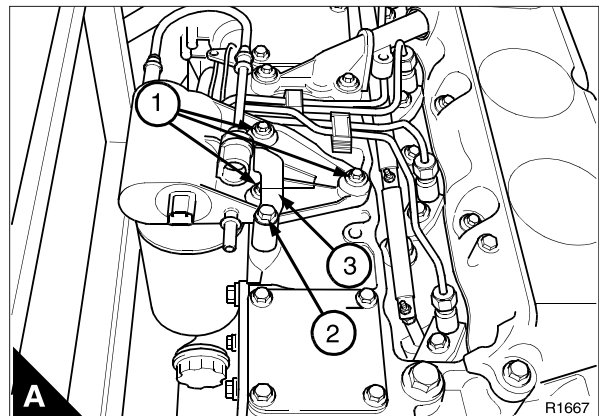

13

11

10

To fit

Operation 12-2

Special requirements

Special tools		Consumable products	
Description	Part number	Description	Part number
Thermostat tool	27610226	POWERPART Red rubber grease	21820221

- 1 Clean the thermostat housing. Ensure that the grooves for the spring retainers and the seat for the “O” ring are free of debris.
- 2 Ensure that the jiggle pins (A1) in the thermostat are both free to move.
- 3 Lubricate a new “O” ring (B1) with POWERPART Red rubber grease before it is fitted. Fit “O” ring. Place the thermostat (C1) in position in the housing (C3).
- 4 Use the thermostat tool (D1) to push and rotate the thermostat to engage the spring retainers into the grooves in the housing (C2) and (C4).
- 5 Fit the thermostat assembly to the cylinder head and tighten the setscrews.
- 6 Connect the top hose and fill the cooling system.

13

12

4

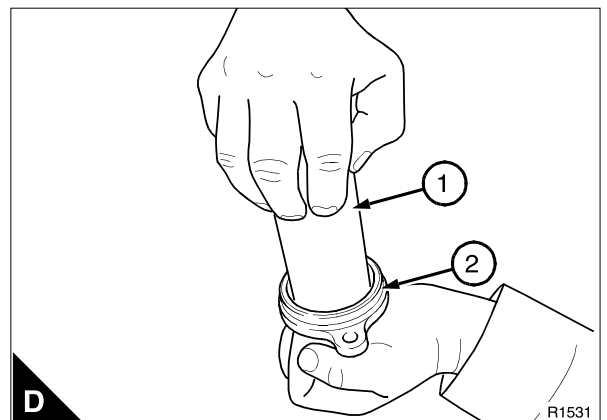
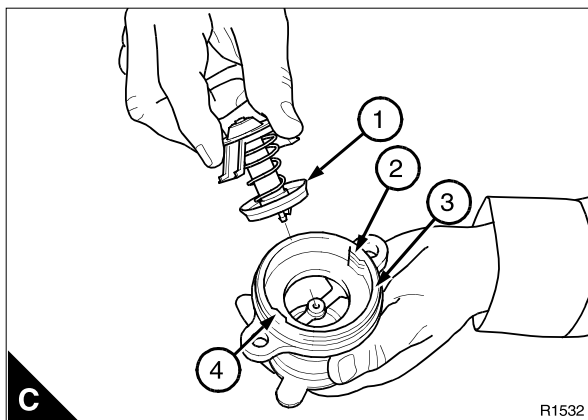
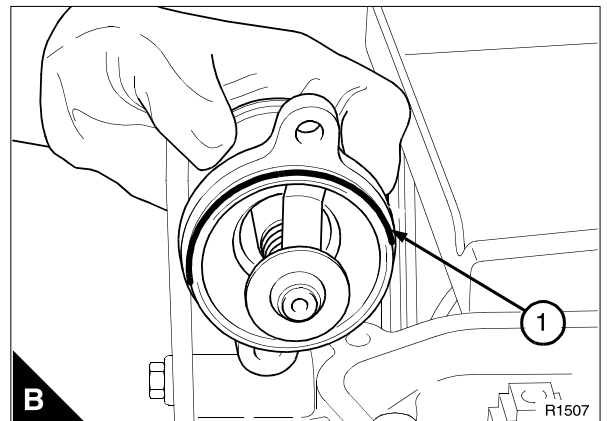
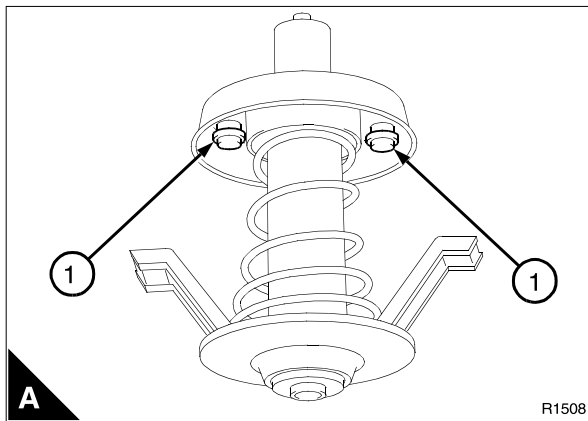

To dismantle and to assemble**Operation 12-12****To dismantle**

- 1 Remove the oil cooler from the cylinder block, see Operation 12-10.
- 2 Remove the four setscrews (A1) from the oil cooler and remove the cooler element.

⚠ Do not allow compressed air to contact your skin. If compressed air enters your skin, obtain medical help immediately.

- 3 Clean the element and check for cracks. If a solution is used to clean the outside of the element, ensure that this does not enter the element. Check that there are no restrictions to the flow of lubricating oil through the element of the oil cooler. If the inside of the element needs to be cleaned, use a solvent which is suitable for copper. Dry the element with low pressure air and then flush it with clean engine lubricating oil.

To assemble

- 1 Renew the joints (B1) on the flanges of the element.
- 2 Fit the element to the cover and tighten the setscrews (A1) to the correct torque.
- 3 Fit the oil cooler, see Operation 12-11.

13**12**

14

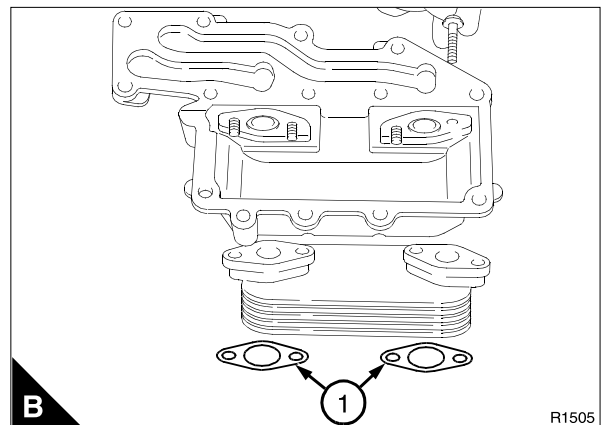
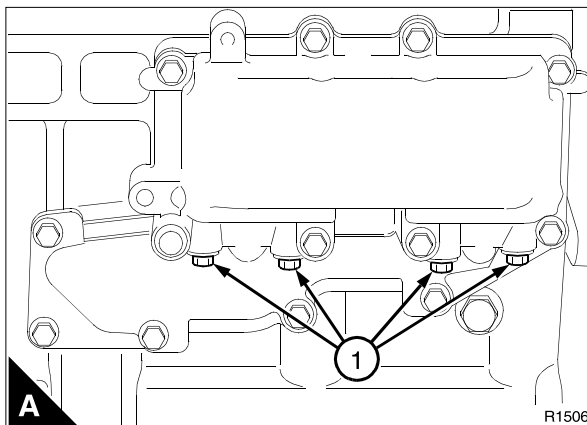

RING GEAR

To remove and to fit

Operation 13-2

To remove

⚠ Wear eye protection and suitable protective clothing during this operation.

Before the ring gear is removed, check the position of the chamfer on the teeth. To remove the ring gear use a hammer and a chisel to break the ring. Ensure that the flywheel is not damaged during this operation.

To fit

The ring gear is heated onto the flywheel. When a new gear is to be fitted, ensure that it is not heated to more than 250°C (480°F). Ensure that the chamfer on the teeth of the gear is in the correct direction.

13

13

2

To maintain the brush gear and the commutator**Operation 14-8**

Repairs to the starter motor are not recommended. Your Perkins Dealer/Distributor has specialist equipment and personnel with the correct training to repair your starter motor.

To test on the engine**Operation 14-9**

Ensure that the battery is fully charged.

Turn on the lights and operate the starter switch. If no lights are fitted to the machine, connect a voltmeter across the battery terminals and operate the starter switch.

If the starter does not operate but the lights keep their power, or there is no voltage drop across the battery, check the switch and all the connections and wires. Slow action of the starter can be caused by faulty connections.

13**14**

8

To insert a pin or socket into a connector.

- ⚠ • Do not bend the wires directly from the rear of the connector as distortion of the rear seal will result, and this will allow water to enter the connector. (See illustration on page 245).
- Ensure that all ECM and MIC connector holes that are not used by a wire to a socket or a pin, are closed by a blanking plug to ensure a waterproof seal. The blanking plugs must be inserted into the connector so that the head of the blanking plug is pushed against, but not into, the connector end seal. (See illustration on page 245).

Note :

- The procedure is the same for Diagnostic, ECM and MIC connectors.
- New pins and sockets are supplied with a short length of wire fitted.
- Any pin or socket holes that are not used in the connector must have blanking plugs fitted.

- 1 Hold the wire (D1) approximately 25,4 mm (1.0 inch) behind the pin or socket.
- 2 Hold the connector with the rear of the connector towards you.
- 3 Push the pin or socket (E1) or socket through the connector rear seal.
- 4 Push the pin or socket (F2) into the connector until the pin or socket is against the locking mechanism (F1).
- 5 Push the pin or socket (F3) until the locking mechanism (F4) is in position behind the pin or socket.
- 6 Carefully pull on the wire to test that the pin or socket is locked in position. If the pin or socket pulls out of the connector, repeat the procedure from stage 1.

- ⚠ **After the repair of Diagnostic, ECM and MIC connectors, ensure that the seals are fitted and are correctly in position as damage to the connector body can result if they are not.**

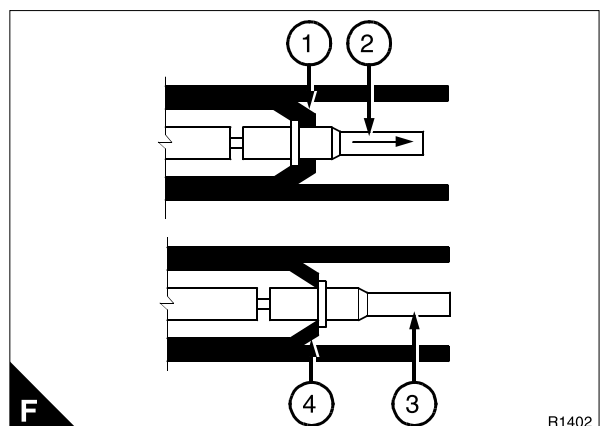
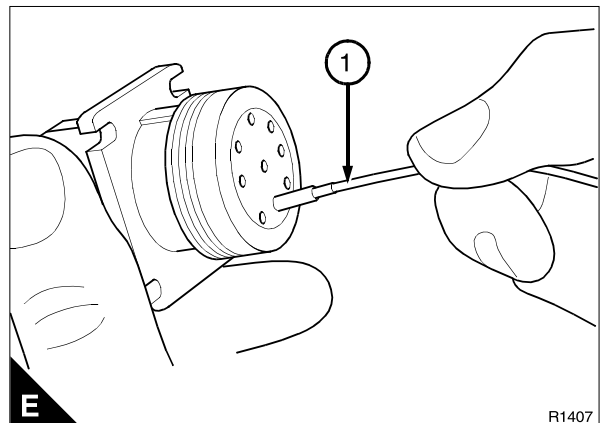
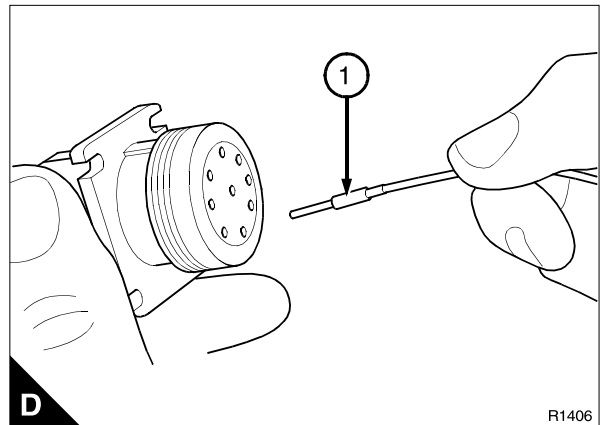

LIST OF SPECIAL TOOLS

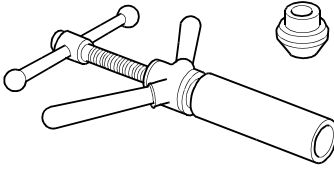
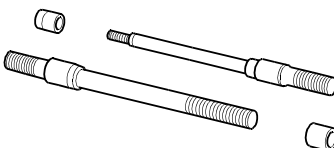
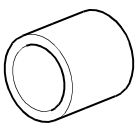
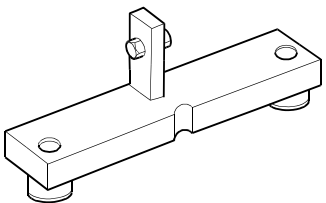
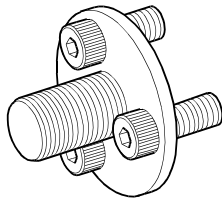
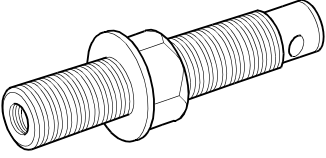
Part number	Part number	Illustration
21825478	Remover / replacer for valve guides (main tool). Reference number PD.1D.	
21828479	Adaptor for use with 21825478. Reference number PD.1D-13.	
27610234	Inlet and outlet valve guide adaptor for use with 21825478.	
27610248	Bosch EPVE fuel pump timing adaptor. Reference number.	
21825496	Gauge for piston height, valve depth and cylinder liner flange; for use with 21825617. Reference number PD.41D.	
21825580	Fastener plate for use with 21825577. Reference number PD.170-3.	
21825577	Replacer tool for seal of timing case cover (main tool). Reference number PD.170.	

- Connect OSHA-approved overhead chain to the engine lifting brackets.
- Remove the engine mount bolts and dampeners.
- Remove the engine flywheel housing to transmission fasteners.

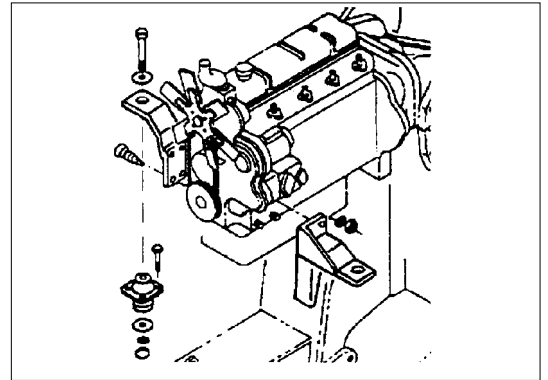

- Remove the cover plate of flywheel housing. Unbolt the torque converter drive plate from the engine flywheel through the top hole.
- Carefully separate engine from transmission by moving the engine away from the transmission. Lift engine out of truck. Use prybars if necessary to assist in separating engine from transmission; do not use unnecessary or excessive force.

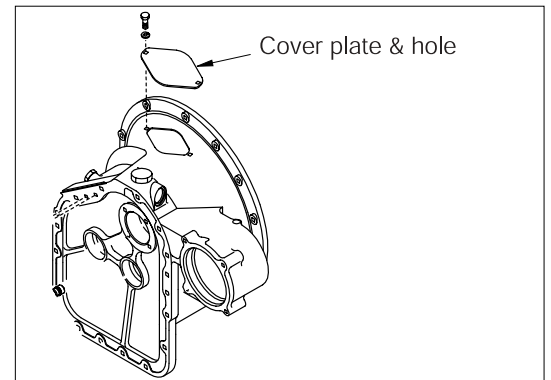

Note :

Do not pry on the torque converter. Nicks and scratches can cause fatigue and leaks.

15

01

4

15

02

4

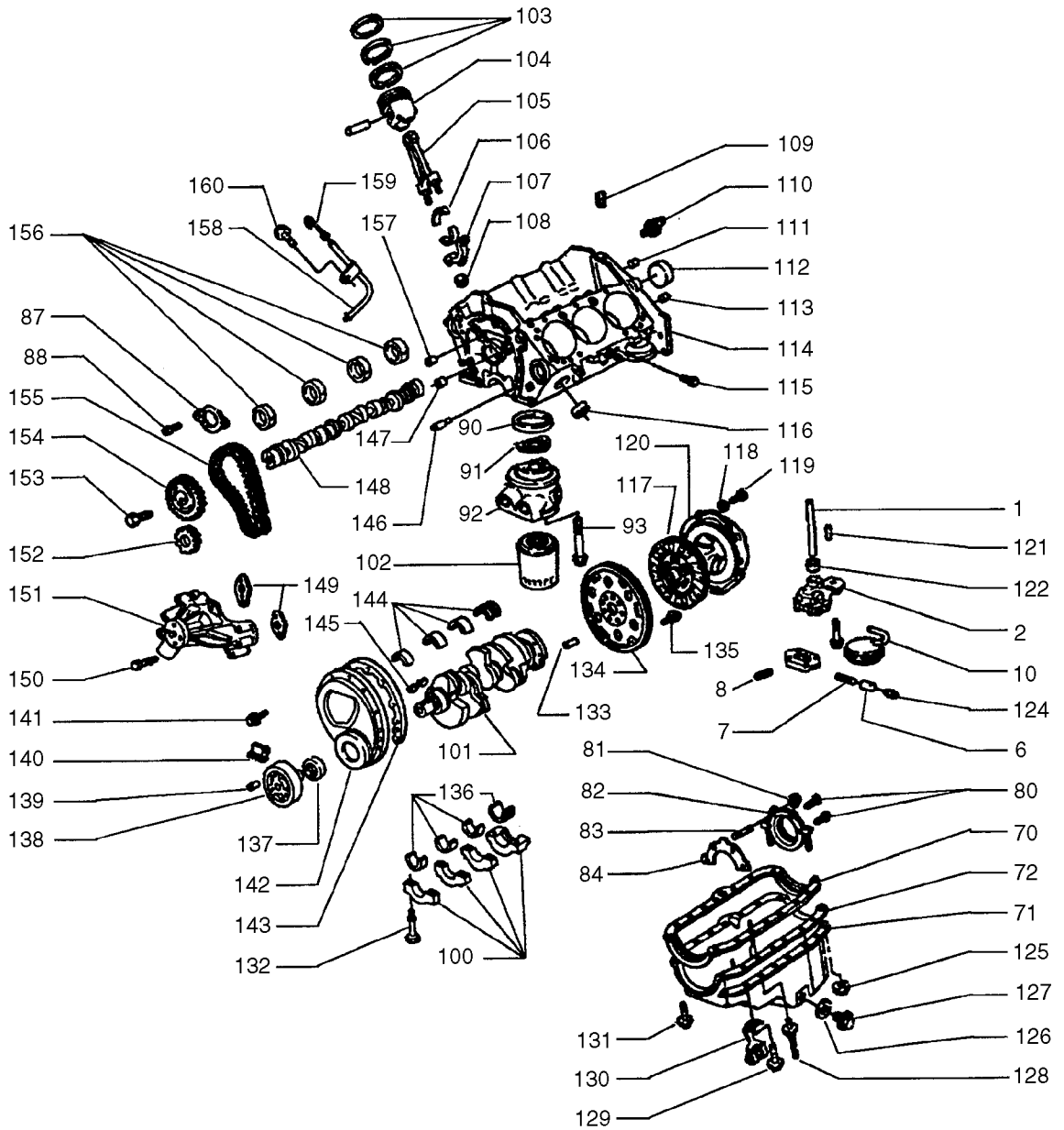

Install or Connect**⚠ NOTICE**

Refer to "Notice" on page 1.

- Oil pan drain bolt.

Tighten

Drain plug to 25 N·m (18 lbs. ft).

- Coolant drain plug and or knock sensor into the block.

Tighten

Coolant drain plug or knock sensor to 14 N·m (124 lbs. in.).

EGR VALVE REMOVAL**Remove or Disconnect**

- Bolts.
- EGR valve.
- Gasket.

15**02**

14

EXHAUST MANIFOLD REMOVAL**Remove or Disconnect**

- Exhaust manifold bolts, washers, and tab washers.
- Heat shields.
- Exhaust manifold.

COOLANT PUMP REMOVAL**Remove or Disconnect**

- coolant pump bolts.
- coolant pump.
- Gaskets.

ROCKER ARM COVER REMOVAL**Remove or Disconnect**

- Rocker arm cover bolts(1).
- Rocker arm covers (2).
- Gaskets.

INTAKE MANIFOLD REMOVAL**Remove or Disconnect**

- Intake manifold bolts.
- Intake manifold.
- Gaskets.

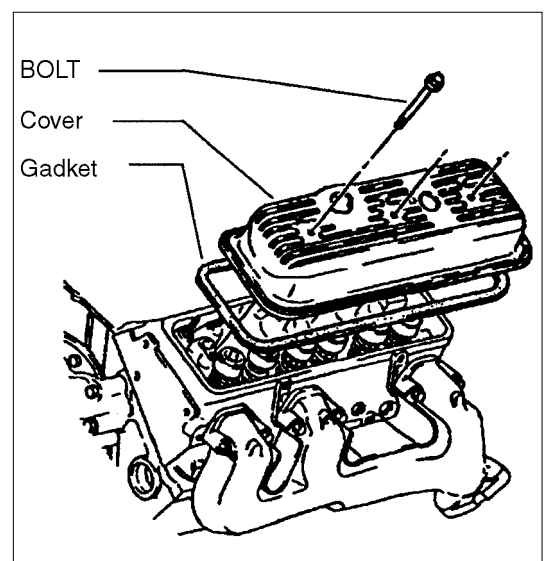

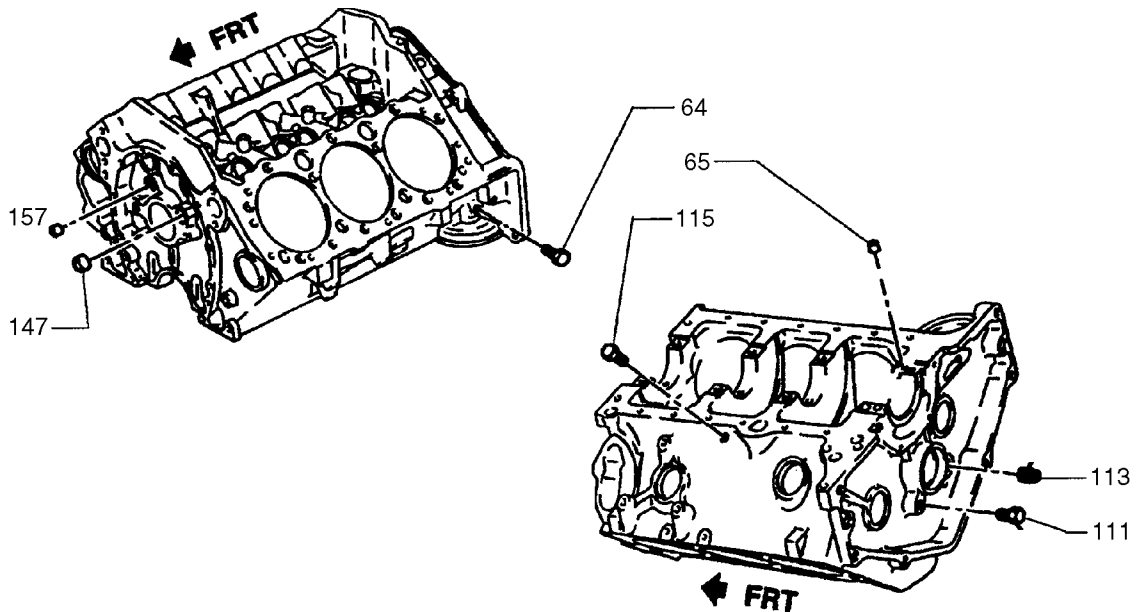

- 64. Plug, oil pressure crossover hole
- 66. Plug, oil pressure crossover hole
- 111. Plug, oil gallery hole
- 113. Plug, oil gallery hole

- 115. Plug, engine block coolant drain hole
- 147. Plug, oil gallery hole
- 157. Plug, oil gallery hole

Engine Block Coolant Drain and Oil Gallery Plugs

A solvent tank large enough to hold the larger engine parts will be needed as well as various bristle brushes and gasket scrapers. A source of compressed air will also be helpful in the cleaning operations.

Special tools are listed and illustrated throughout this section with a complete listing at the end of the section. These tools (or their equivalents) are specially designed to quickly and safely accomplish the operations for which they are intended. They should not be used in operations for which they are not designed. These special tools, when they are properly used, will also minimize possible damage to engine.

Some precision measuring tools are required for inspection of certain critical components. These include micrometers, torque wrenches, feeler gages, dial indicator set, etc. The inspection work, when performed with the proper methods and tools, is most important.

The rebuilt engine cannot be expected to perform properly if the parts are worn beyond acceptable limits are reused.

INSTALLING THE PISTON RINGS

Figures 34 Through 36

Measure

1. Ring end gap as follows:

- Select rings comparable in size to the piston being Used.
- Slip the compression ring into the cylinder bore and press it down about 7mm (0.250 in.) above ring travel.

Make sure the ring is square with the cylinder wall.

- Measure the space or gap between the ends of the ring with a feeler gage.
- Refer to "Specifications" in the proper section for correct gap.
- If the gap between the ends of the ring is not as specified, remove the ring and try another for fit.

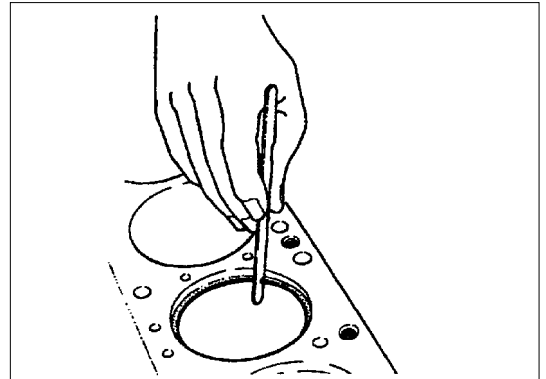

15

02

34

Inspect

1. Ring fit as follows:

- Fit each compression ring to the piston on which it is going to be used.
- Slip the outer surface of the top and second compression ring into the respective piston ring groove, to make sure that the ring is free. If binding occurs at any point, the cause should be determined. If binding is caused by the ring groove, correct by depressing the groove with a fine cut file. If the binding is caused by a distorted ring, try a new ring.

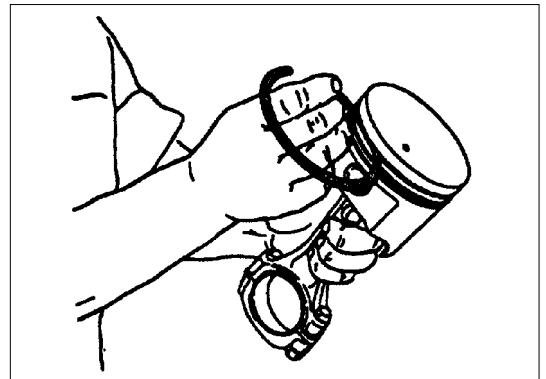

HYDRAULIC LIFTERS

The type of hydraulic lifters used in this engine are the roller type. Hydraulic lifters are serviced only as an assembly. No internal parts are available.

⚠ Important

- Service is limited to a disassembly and cleaning. Discard any valve lifter(s) that are worn.
- Whenever the camshaft needs to be replaced, a new set of hydraulic lifters must also be installed.

CYLINDER HEAD

DISASSEMBLY

Tool required
J 8062 Valve Spring Compressor

Remove or disconnect

1. Valve keepers (67).
 - Compress the springs with 8062 (figure 46).
 - Remove the keepers (67).
 - Remove J 8062.
2. Intake valve components.
 - Cap (68).
 - Shield (69).
 - Seal (71).
 - Damper (72).
 - Spring (73).
3. Exhaust valve components.
 - Rotator (75)
 - Shield (69).
 - Seal (71).
 - Damper (72).
 - Spring (73).

- | | |
|------------------|------------------|
| 67. Valve keeper | 73. Spring |
| 68. Cap | 74. Intake valve |
| 69. Shield | 75. Rotator |
| 70. O-ring seal | 76. Exhaust |
| 71. Seal | |

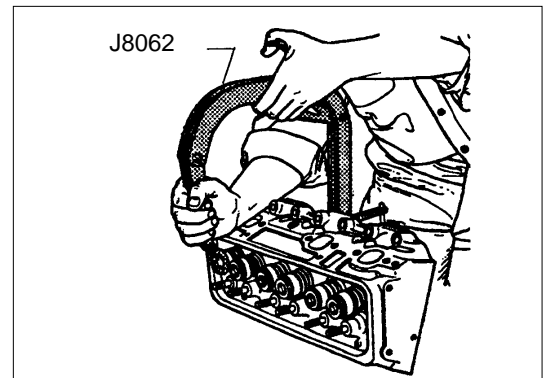

Compressing the valve springs

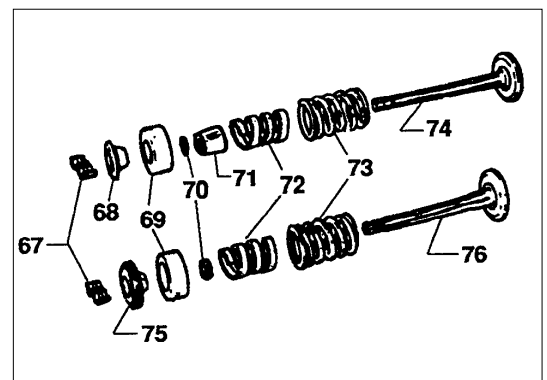

Valves and components

⚠ Important

- Place the valves (74 and 76) in an organizer rack so they can be replaced in their original position at reassembly.

MEASURING MAIN BEARING CLEARANCE

The simplest, most accurate way to measure main bearing clearance is with the use of gaging plastic. This wax-like material compresses evenly between the bearing and journal surfaces without damaging them. proceed as follows :

Clean

- All oil from the crankshaft journal and main bearing inserts.

Install or connect

1. Main bearing insert sand crankshaft.
2. Gaging plastic.
 - Begin with the rear main bearing.
 - Wipe the oil from the crankshaft journal and the lower main bearing insert.
 - Place a piece of gaging plastic the full width of the lower bearing insert (parallel to the crankshaft) on the journal. Do not rotate the crankshaft while the gaging plastic is between the bearing and journal.

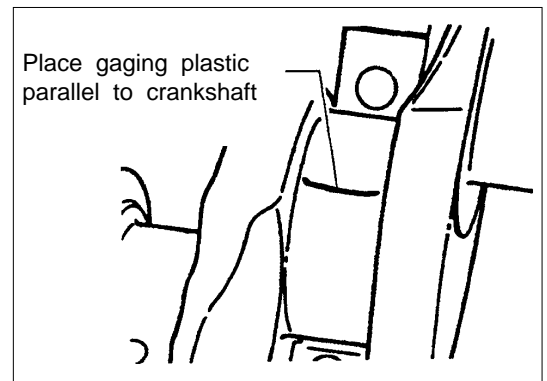

Placing the gaging plastic on the bearing journal

3. Main bearing cap and bolts.

⚠ NOTICE

Refer to "Notice" on page 15-02-1.

Tighten

- Bolts to Specification.

Remove or Disconnect

- Main bearing cap. DO NOT REMOVE THE GAGING PLASTIC FROM THE JOURNAL OR LOWER MAIN BEARING INSERT.

Measure

- Gaging plastic as follows:
 - The flattened gaging plastic will be found adhering to either the lower bearing insert or journal.
 - On the edge of the gaging plastic envelope there is a graduated scale. Without removing the gaging plastic, measure its compressed width (at the widest point) with the graduations on the gaging plastic envelope.

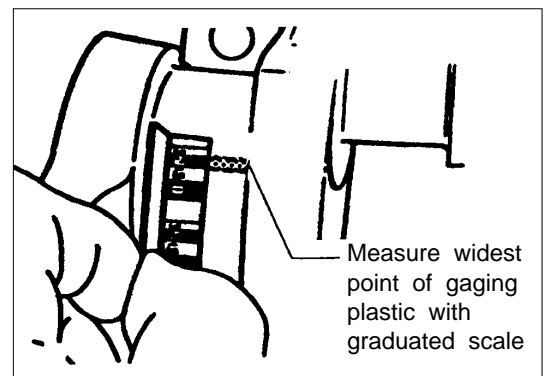

Measuring the gaging plastic

TORSIONAL DAMPER INSTALLATION

Tool Required :

39046 Torsional Damper Ruller and Installer

Install or Connect

1. Crankshaft key (if removed).

⚠ NOTICE :

The inertial weight section of the torsional damper is assembled to the hub with rubber type material. The correct installation procedures with the proper tool) must be followed or movement of the inertial weight section of the hub will destroy the tuning of the torsional damper.

2. Stud (item A.,) to the crankshaft. Thread the stud fully into the tapped hole in the crankshaft.

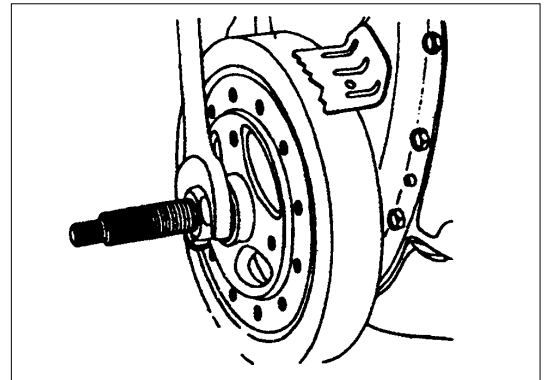

Installing the torsional damper

3. Torsional damper over the end of the stud. Align the key way in the torsional damper shaft with the crankshaft
4. Bearing, washer, and nut (figure 71).
 - Turn the nut to pull the vibration damper into place.
 - Remove the tool.

⚠ NOTICE :

Refer to "Notice" on page 15-02-1.

5. Torsional damper bolt and washer.

Tighten

- Bolt to 95 N-m (70 lbs-ft).

Tighten

- Bolts to 22 N·m (16 lbs·ft).

FLYWHEEL INSTALLATION**Install or Connect**

1. Flywheel.

⚠ NOTICE

Refer to “Notice” on page 15–02–1.

2. Flywheel bolts.

Tighten

- Bolts to 100 N·m (74 lbs·ft).

COOLANT PUMP INSTALLATION**Install or Connect**

1. Gaskets.
2. Coolant pump.

⚠ NOTICE

Refer to “Notice” on page 15–02–1.

3. Coolant pump bolts.

Tighten

- Coolant pump bolts to 40 N·m (30 lbs·ft).

ENGINE ACCESSORY INSTALLATION

Install the engine accessories (distributor, oil filter, generator, etc.) as directed in the proper on-vehicle Truck Service Manual. Connect all vacuum hoses and electrical equipment the same way as removed.

⚠ CAUTION

Safety is an important consideration for any repair facility, and repairing LPG fueled machinery is no exception. Refer to the NFPA (National Fire Protection Agency) for the appropriate fire extinguisher specifications and fluorescent lighting requirements.

Propane has a heavier than air vapor density and will fall if a leak occurs, while natural gas, by comparison, will rise in the event of a leak (Figure 1).

This is an important property that technicians need to be aware of when performing maintenance. When repairing propane machinery, the work should be performed in the lowest point of the facility where possible. The tank supply should be shut off, except when required for running equipment.

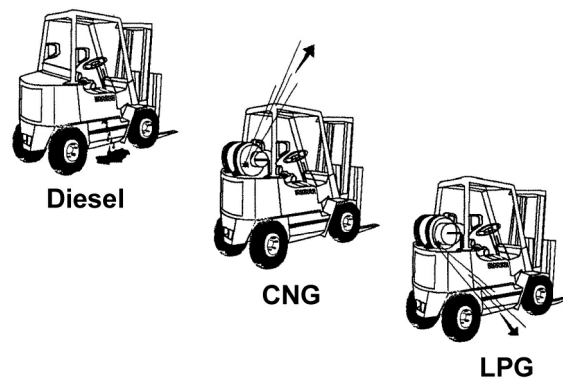

Figure 1

MI-04 LP FUEL FILTER

After exiting the fuel tank, liquid propane passes through a serviceable inline fuel filter to the electric fuel lock off. (Figure 10) shows a typical inline type LP fuel filter manufactured by Century. The primary function of the fuel filter is to remove particles and sediments that have found their way into the tank. The LP fuel filter will not remove heavy end solids and paraffin's that build up in LPG fuel systems as a result of vaporization.



Figure 10

MI-04 FUEL LOCK-OFF (ELECTRIC)

The fuel lock-off is a safety shutoff valve, normally held closed by spring pressure, which is operated by an electric solenoid and prevents fuel flow to the regulator/converter when the engine is not in operation. This is the first of three safety locks in the MI-04 system. (Figure 11) shows the electric fuel lock assembly.

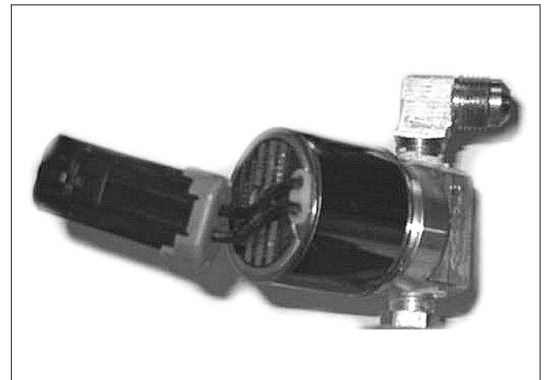

Figure 11

In the MI-04 design, power is supplied to the fuel lock-off with the SECM controlling the lock-off ground (earth) connection.

The lock-off remains in a normally closed (NC) position until the key switch is activated, this supplies power to the lock-off and the SECM but will not open the lock-off until the SECM provides the lock-off ground connection. This design gives the SECM full control of the lock-off while providing additional safety by closing the fuel lock-off in the unlikely event of a power failure, wiring failure or module failure.

When the liquid service valve in the fuel container is opened liquid propane flows through the LP filter and through the service line to the fuel lock-off. Liquid propane enters the lock-off through the 1/4" NPT liquid inlet port and stops with the lock-off in the normally closed position. When the engine is cranked over the main power relay applies power to the lock-off and the SECM provides the lock-off ground causing current to flow through the windings of the solenoid creating a magnetic field. The strength of this magnetic field is sufficient to lift the lock-off valve off of its seat against spring pressure. When the valve is open liquid propane, at tank pressure, flows through the lock-off outlet to the pressure regulator/converter. A stall safety shutoff feature is built into the SECM to close the lock-off in case of a stall condition. The SECM monitors three engine states. Crank, when the VR sensor detects any engine revolutions. Stall, when the key is in the ON position but the VR sensor detects no engine revolutions, and the Run state, when the engine reaches pre-idle RPM. When an operator turns on the key switch the lock-off is opened but if the operator fails to crank the engine, the SECM will close the lock-off after 5 seconds.

HEGO voltage is converted to an air fuel ratio value. This value is then compared to a target value in the SECM. The target value is based on optimizing catalyst efficiency for a given load and speed. The SECM then calculates any corrections that need to be made to the air fuel ratio.

The system operates in open loop fuel control until the engine has done a certain amount of work. This ensures that the engine and HEGO are sufficiently warmed up to stay in control. In open loop control, the FTV duty cycle is based on engine speed and load. Once the HEGO reaches operating temperature the fuel management is in closed loop control for all steady state conditions, from idle through full throttle. In closed loop mode, the FTV duty cycle is based on feedback from the HEGO sensor. In order to handle transient loads, engine RPM and load is compared to a threshold used by the SECM. When this threshold is exceeded, the FTV duty cycle will be set to a Feed Forward Adaptive value.

The SECM then makes any necessary corrections to the air fuel ratio by controlling the inlet fuel pressure to the air/fuel mixer. Reducing the fuel pressure leans the air/fuel mixture and increasing the fuel pressure enriches the air/fuel mixture. Control is achieved by modulating the fuel trim.

15

04

22

CATALYTIC MUFFLER

All exhaust gases pass through a catalytic converter that is mounted on the exhaust pipe. It filters these gases through a dense honeycomb structure coated with precious metals such as platinum, palladium, and rhodium. Chemical reactions occur on these surfaces to convert the pollutants into less harmful gases. Catalytic converters store oxygen on lean mixtures (less than optimal amount of fuel) and release oxygen on rich mixtures (more than optimal amount of fuel). The primary pollutant produced on the lean swing is nitrous oxide. Oxygen is removed from nitrous oxide by the converter, resulting in nitrogen gas, a harmless emission. On the rich cycle, the primary pollutant is carbon monoxide. By adding the oxygen that was stored on the lean cycle to the carbon monoxide, carbon dioxide is produced.

Oxidation and Reduction Process

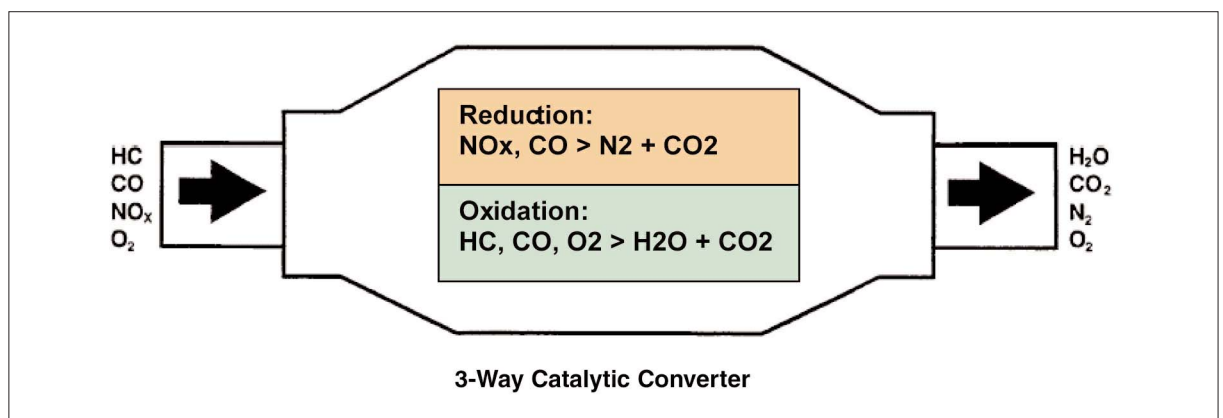
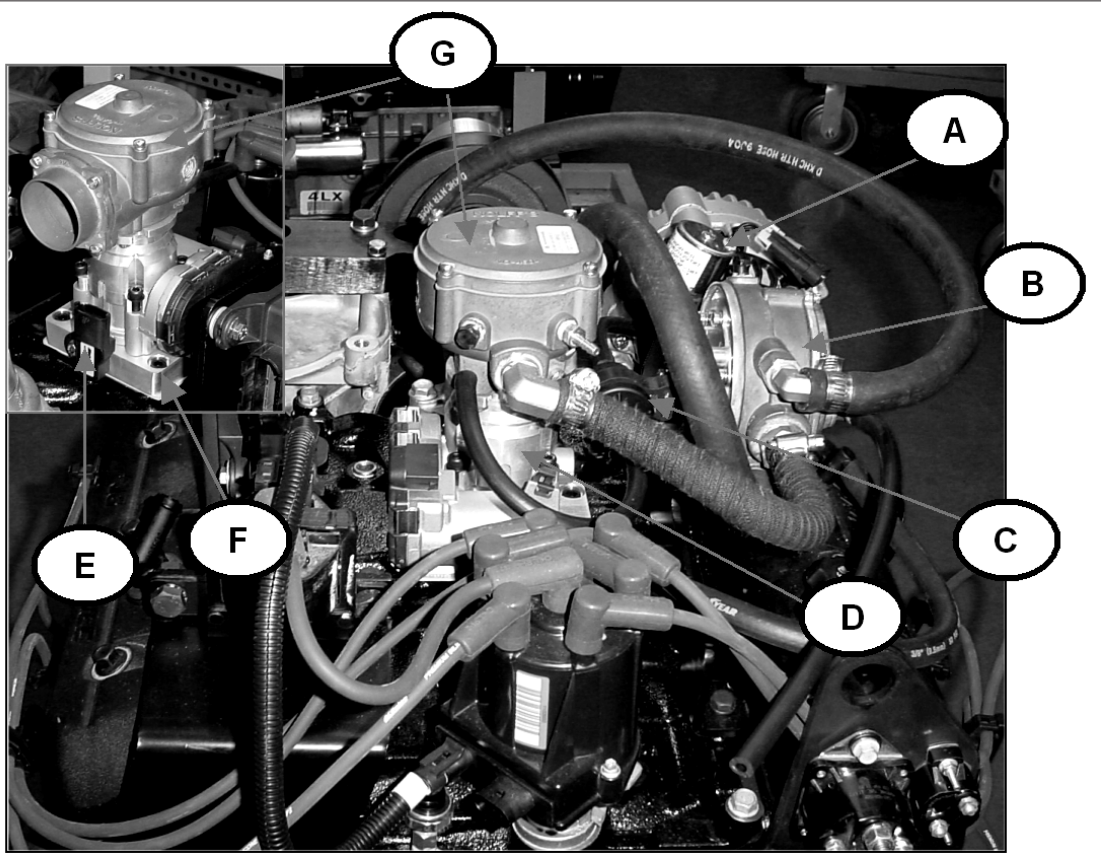

Figure 25



15

04

32

PRESSURE REGULATOR/CONVERTER TESTING AND INSPECTION

- Visually inspect the pressure regulator/converter (B) housing for coolant leaks. Refer to the pressure regulator/converter section of the service manual if maintenance is required.

(i) NOTE

For pressure testing and internal inspection of the pressure regulator/converter, refer to the pressure regulator/converter section of the service manual.

FUEL TRIM VALVE INSPECTION (FTV)

- Visually inspect the Fuel trim valve (C) for abrasions or cracking. Replace as necessary.
- To ensure the valve is not leaking a blow-by test can be performed.
 1. With the engine off, disconnect the electrical connector to the FTV.
 2. Disconnect the vacuum line from the FTV to the pressure regulator/converter, at the converter's tee connection.
 3. Lightly blow through the vacuum line connected to the FTV. Air should not pass through the FTV when de-energized. If air leaks past the FTV when de-energized replace the FTV.

CHAPTER 5.0 MI-04 LP ADVANCED DIAGNOSTICS

ADVANCED DIAGNOSTICS

The MI-04 systems are equipped with built-in fault diagnostics. Detected system faults can be displayed by the Malfunction Indicator Lamp (MIL) as Diagnostic Fault Codes (DFC) or flash codes, and viewed in detail with the use of service tool software. When the ignition key is turned ON the MIL will perform a self-test, illuminate once and then go OFF. If a detected fault condition exists, the fault or faults will be stored in the memory of the small engine control module (SECM). Once a fault occurs the MIL will illuminate and remain ON. This signals the operator that a fault has been detected by the SECM.

READING DIAGNOSTIC FAULT CODES

All MI-04 fault codes are two digit codes. When the fault codes are retrieved (displayed) the MIL will flash for each digit with a short pause (.5 seconds) between digits and a long pause (1.2 seconds) between fault codes. A code 12 is displayed at the beginning of the code list.

EXAMPLE : A code 26 has been detected (ETCSticking) and the engine has shutdown and the MIL has remained **ON**. When the codes are displayed the MIL will flash one time (1), pause, then flash two times (2). This identifies a twelve (12), which is the beginning of the fault list. It will then pause for 1.2 seconds (long pause) and flash two times (2), pause, then flash six times (6). This identifies a twenty-six (26), which is the ETCSticking fault. If any additional faults were stored the SECM would again have a long pause, then display the next fault by flashing each digit. Since no other faults were stored there will be a long pause then one flash (1), pause, then two flashes (2). This identifies a twelve meaning the fault list will begin again.

DISPLAYING FAULT CODES (DFC) FROM SECM MEMORY

To enter code display mode you must turn **OFF** the ignition key. Now turn **ON** the key but do not start the engine. As soon as you turn the key to the **ON** position you must cycle the foot pedal by depressing it to the floor and then fully releasing the pedal (pedal maneuver). You must fully cycle the foot pedal three (3) times within five (5) seconds to enable the display codes feature of the SECM. Simply turn the key **OFF** to exit display mode. The code list will continue to repeat until the key is turned **OFF**. An automatic code display feature is activated if a foot pedal fault condition exists. This feature enables the service technician to view the fault codes by turning the key to the **ON** position, if a foot pedal malfunction is preventing the retrieval of the stored fault codes from the SECM.

Malfunction Indicator Light(MIL)

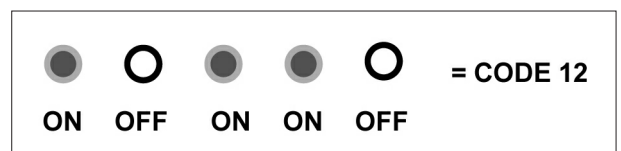

15

04

42

DFC	Probable Fault	Action	Corrective Action, First Check
43	EST1High Coil driver signal high or over-current	Stored Fault Code (MIL Only)	<p>Check coil driver wiring and connector for open circuit SECM PIN 7(EST1) to IGNITION MODULE PIN D (4-PIN CONNECTOR)</p> <p>VERIFY GND ON IGNITION MODULE PIN A (OF BOTH CONNECTORS) VERIFY +12VDC ON IGNITION MODULE PIN B (OF BOTH CONNECTORS)</p> <p>To check the Ignition module internal circuit disconnect both connectors and measure the resistance from pin to pin</p> <p><i>*See Ignition Module resistance check in Chapter 6.0</i></p>
52	LowOilPressure Low Engine Oil Pressure	Delayed Engine Shutdown	<p>Check engine oil level</p> <p>Check electrical connection to the oil pressure switch</p> <p>SECM PIN 23 to Oil Pressure Switch</p>
53	BatterySensorInputLow Battery voltage measured below +8.0 VDC	Stored Fault Code (MIL Only)	<p>Check battery voltage</p> <ul style="list-style-type: none"> • Perform maintenance check on electrical connections to the battery and chassis ground • Check battery voltage during starting and with the engine running to verify charging system and alternator function <p>Measure battery power at the SECM with a multimeter</p> <p>SECM PIN 13 (BATT +) to SECM PIN 14 (BATT -)</p>

HOSE CONNECTIONS

Proper operation of the closed loop control greatly depends on the correct vacuum hose routing and fuel line lengths. Refer to the connection diagram (Figure R1) for proper routing and maximum hose lengths when reinstalling system components.

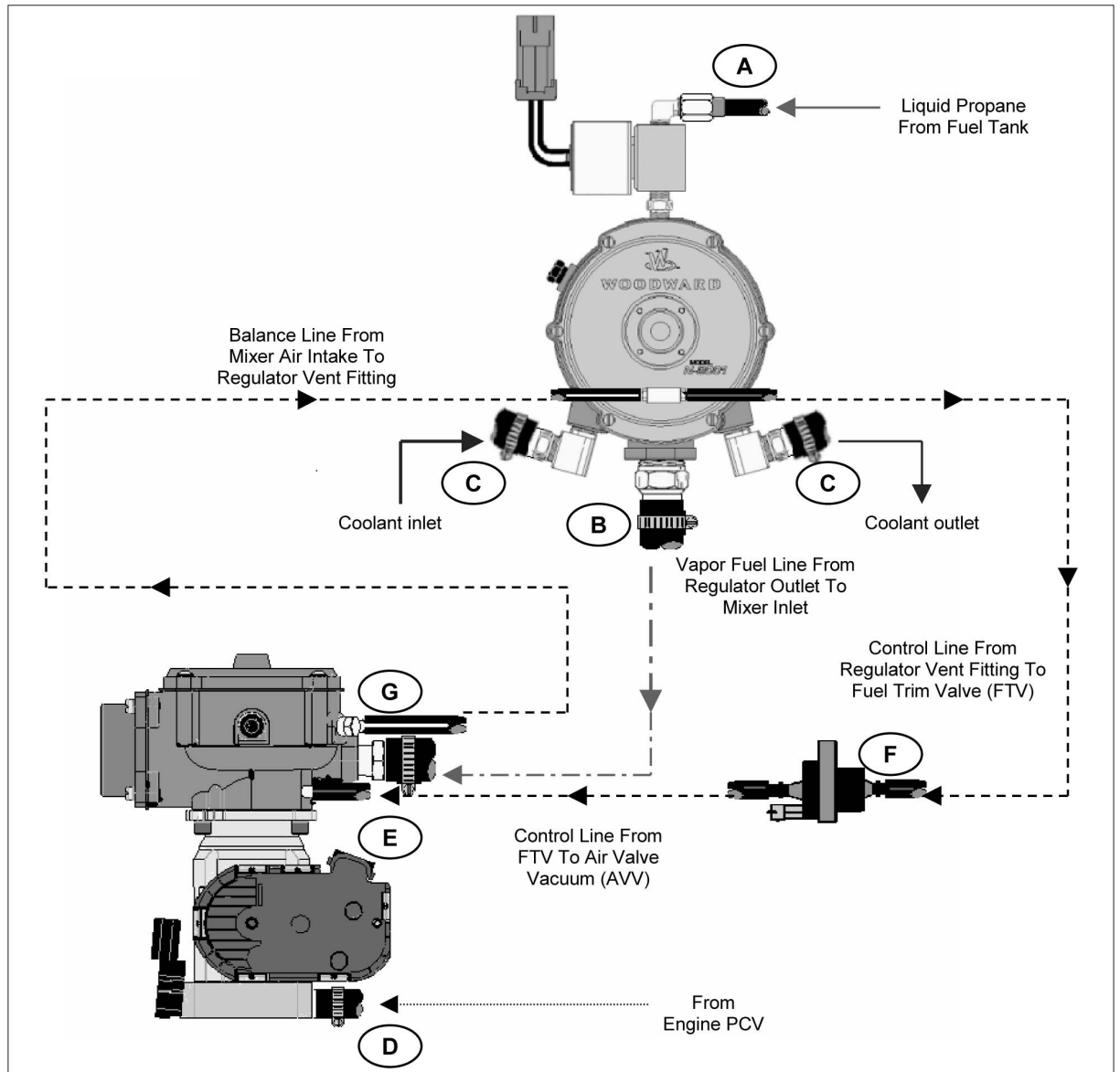

Figure R1

Hose Type

- A. 3/8" Female flare stainless steel braided-neoprene high-pressure fuel line.
(Fabric braid can be used on assemblies less than 60 inches) **Fuel Tank Valve Closed!**
- B. 5/8" I.D. Vapor Hose-Wire Reinforced (15 inch maximum length)
- C. 5/8" I.D. Hose-Water (*Maximum length specified by engine manufacturer)
- D. 1/2" I.D. Rubber Hose (*Maximum length specified by engine manufacturer)
- E. 7/32" I.D. Vacuum Hose (10 inch recommended maximum length)
- F. 7/32" I.D. Vacuum Hose (11.5 inch recommended maximum length)
- G. 7/32" I.D. Vacuum Hose (18 inch recommended maximum length)

Copyrighted Material
Intended for CLARK dealers only
Do not sell or distribute

4. Place the O-ring Spacer over the outside throat of the throttle. This spacer is necessary to assure that the O-ring, which seals the throttle to the adapter, properly seats against the throttle adapter.
5. Place the throttle adapter O-ring over the outside throat of the throttle, below the throttle bore retaining lip and on top of the O-ring Spacer (Figure M17). Apply a generous amount of lubricating grease (vacuum grease) to the O-ring and fully seat it against the machined surface.
6. Slide the pre-assembled mixer/throttle adapter assembly over the throat of the throttle, aligning the mounting holes of the adapter with the mounting holes of the throttle (Figure M18). Face the fuel inlet of the mixer toward the plastic motor assembly cover of the electronic throttle assembly.



Figure M18

(i) NOTE

Avoid pinching the O-ring in the cutaway of the throttle adapter. This will damage the O-ring and cause a manifold leak in the system.

7. Tighten the four mounting bolts hand tight using a crossing pattern from one side of the adapter to the other. This prevents the adapter O-ring from misaligning against the throttle, which may cut the O-ring and cause an intake leak. Finally, tighten the four throttle adapter fasteners to the specified torque values
8. Install the TMAP sensor to the manifold adapter. Apply a small amount of vacuum grease to the TMAP sensor O-ring and install the sensor into the manifold adapter, tighten the fasteners to specified torque values.
9. Connect the air inlet hose from the air cleaner
10. Connect the balance line to the orifice barb and the FTV vacuum line.

(i) NOTE

Be careful not to over tighten the sensor retaining screw or damage to the sensor housing may result.

- Remove 1st and 2nd clutch assembly.

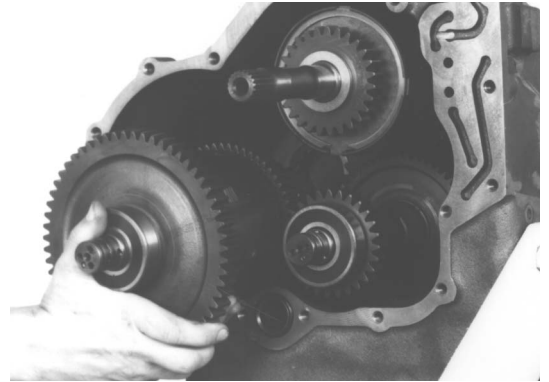

- Remove forward and reverse clutch assembly.

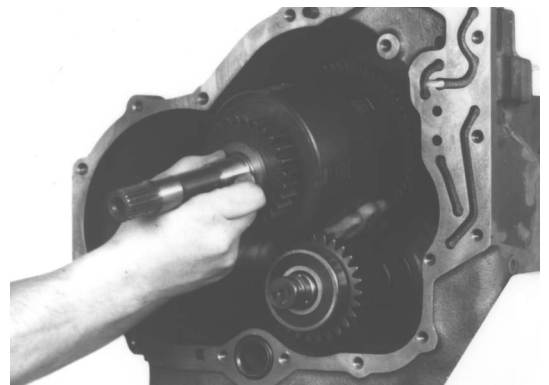

- Remove 3rd clutch assembly.

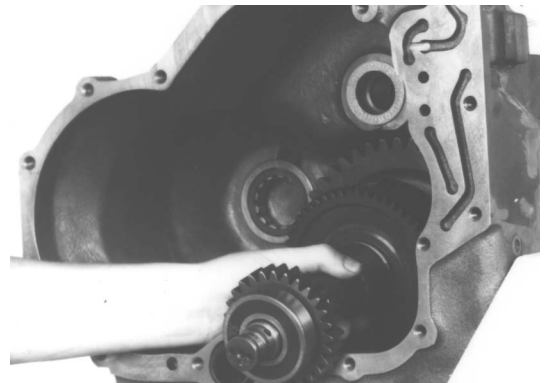

- Remove 3rd speed clutch shaft pilot bearing.

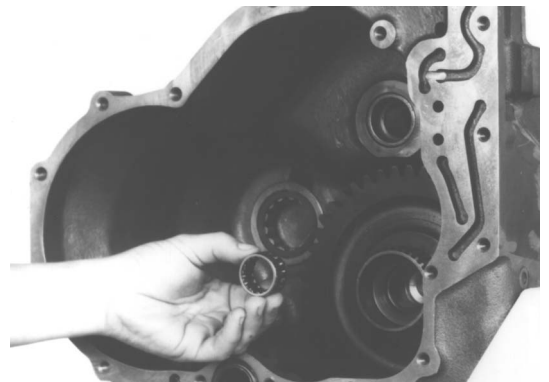

20

02

6

- Remove retainer ring retainer.



- Remove disc springs.



- Remove clutch piston wear plate.



- Turn clutch over and tap clutch shaft on a block of wood to remove clutch piston.



- Position inner thrust washer on shaft.



- Position thrust bearing on shaft.



- Position outer thrust washer on shaft.

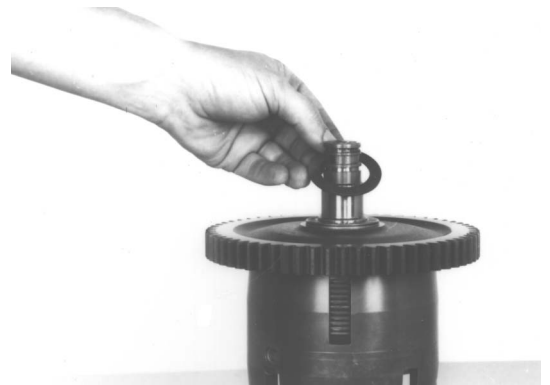

- Install clutch shaft front bearing.

⚠ Bearing has a shield in it. This shield must face upward.

⚠ Assembly instruction.



- Remove clutch piston.

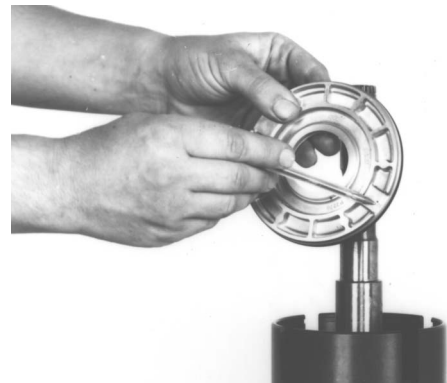

3RD CLUTCH REASSEMBLY

- Clutch piston bleed ball must be clean and free of any foreign material.



36

- Install inner and outer clutch piston seal rings. Size inner ring as previously explained, install clutch piston in clutch drum. Use caution as not to damage sealing rings.



- Install clutch piston wear plate.

20

02

- Remove clutch piston wear plate.

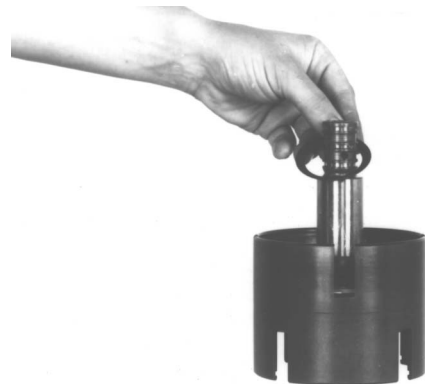

- Remove clutch piston.



20

02

46

FORWARD CLUTCH REASSEMBLY
(See Cleaning and Inspection Page)

- Clutch piston bleed orifice must be clean and free of any foreign material.

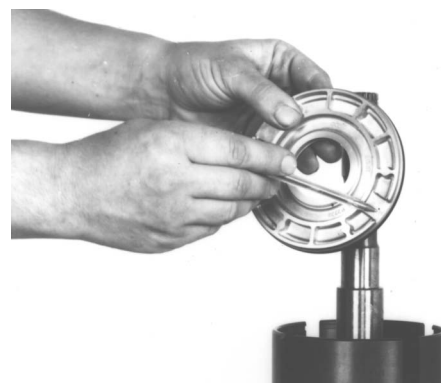

- Install inner and outer clutch piston seal rings. Size inner ring as previously explained. Install clutch piston in clutch drum. Use caution as not to damage sealing rings.

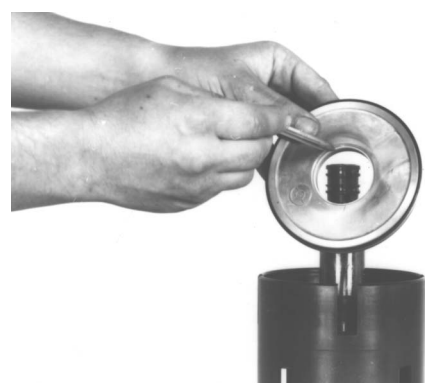

 Assembly instruction.

- Position inner thrust washer on shaft.



- Position thrust bearing on shaft.

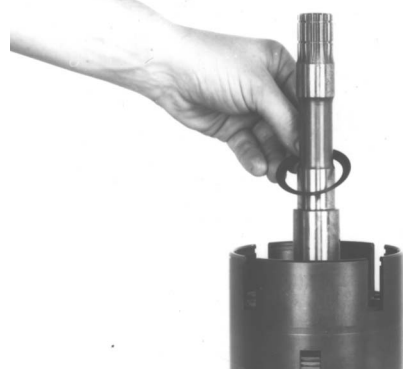

- Position outer thrust washer on shaft.

**20****02**

56

CLEANING AND INSPECTION

• CLEANING

Clean all parts thoroughly using solvent type cleaning fluid. It is recommended that parts be immersed in cleaning fluid and moved up and down slowly until all old lubricant and foreign material is dissolved and parts are thoroughly cleaned.

⚠ CAUTION

Care should be exercised to avoid skin rashes, fire hazards, and inhalation of vapors when using solvent type cleaners.

① BEARINGS

Remove bearings from cleaning fluid and strike flat against a block of wood to dislodge solidified particles of lubricant. Immerse again in cleaning fluid to flush out particles. Repeat above operation until bearings are thoroughly clean. Dry bearings using moisture-free compressed air. Be careful to direct air stream across bearing to avoid spinning. Do not spin bearings when drying. Bearings may be rotated slowly by hand to facilitate drying process.

② HOUSINGS

Clean interior and exterior of housings, bearing caps, etc., thoroughly. Cast parts may be cleaned in hot solution tanks with mild alkali solutions providing these parts do not have ground or polished surfaces. Parts should remain in solution long enough to be thoroughly cleaned and heated. This will aid the evaporation of the cleaning solution and rinse water. Parts cleaned in solution tanks must be thoroughly rinsed with clean water to remove all traces of alkali. Cast parts may also be cleaned with a steam cleaner.

⚠ CAUTION

Care should be exercised to avoid inhalation of vapors and skin rashes when using alkali cleaner.

All parts cleaned must be thoroughly dried immediately by using moisture-free compressed air or soft, lintless absorbent wiping rags free of abrasive materials such as metal filings, contaminated oil, or lapping compound.

20

02

106

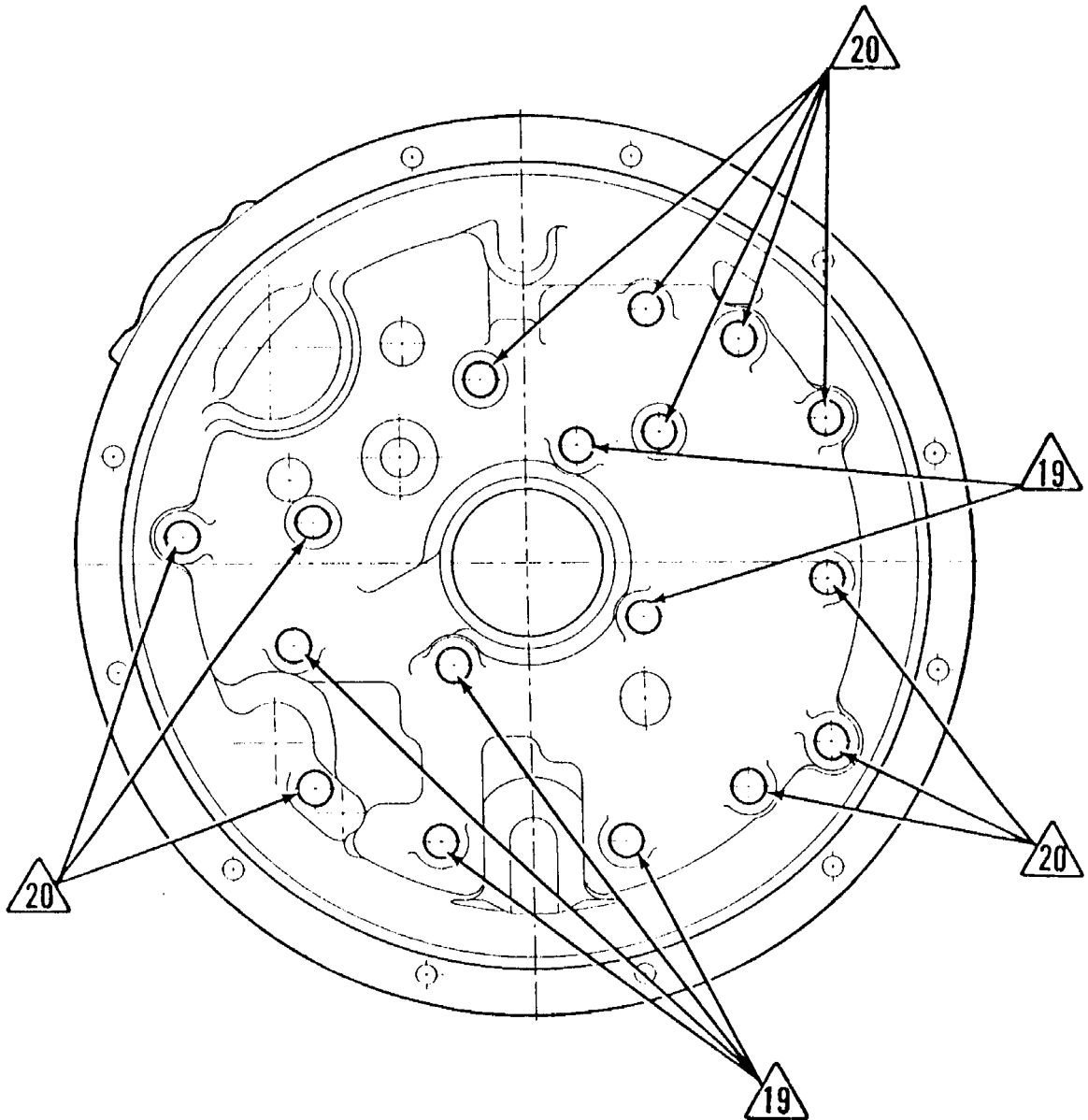

TORQUE SPECIFICATION FOR LUBRICATED OR PLATED SCREWS AND NUTS		
NOMINAL SIZE	GRADE 8.8 or 9.8	GRADE 10.9
	COARSE THREAD N-m (lbf-ft)	COARSE THREAD N-m (lbf-ft)
M10	40~50 (30~37)	60~65 (44~48)
M12	65~75 (50~55)	100~110 (74~81)

PIPE PLUG TORQUE CHART		
TORQUE		
THREAD NPTF	N-m	(lbf-ft)
1/16-27	7~9	(5~7)
1/8-27	9~14	(7~10)
1/4-18	20~27	(15~20)
3/8-18	34~41	(25~30)
1/2-14	41~47	(30~35)
3/4-10	54~61	(40~45)

PERMANENT PLUG METRIC		
TORQUE		
THREAD NPTF	N-m	(lbf-ft)
M18 x 1.5 6H	25~30	(34~41)
M26 x 1.5 6H	45~50	(61~68)

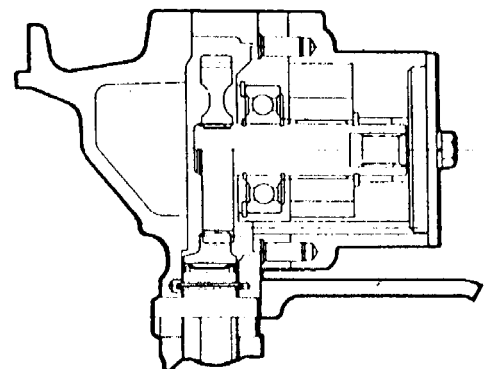

SECTION B-B

Figure J

Copyrighted Material
Intended for CLARK dealers only
Do not sell or distribute

- Pull out the wheel hub.

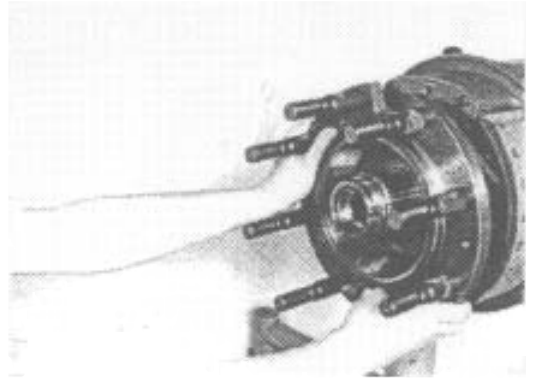

- Pull out shims (1) keeping them together, pull out spacer (2).

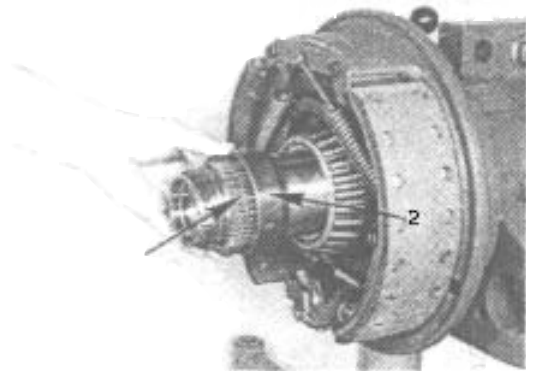
**20****03**

8

- Remove the springs and brake shoes.

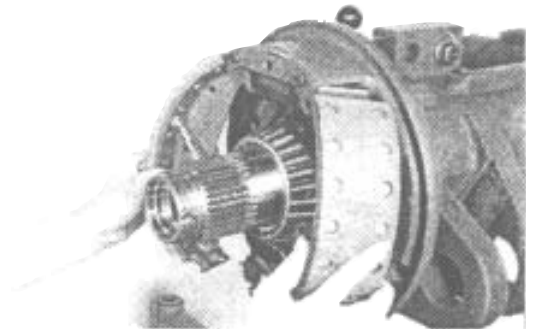

- With suitable puller remove the bearing.

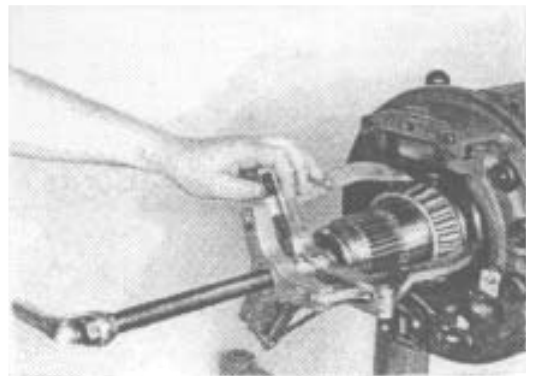

- Install the bearing outer race.



- Fit the pinion shaft assembly.



- Install the tapered roller bearing.

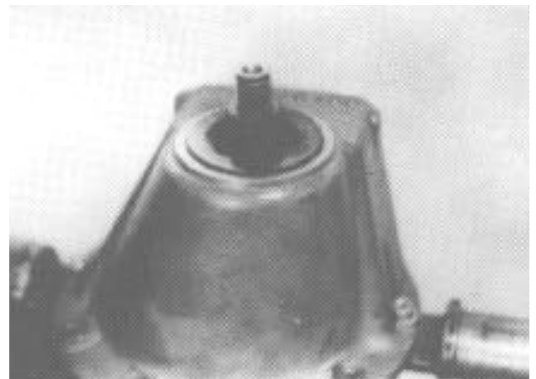

- Fit the circlip.

**20****03**

18

- With tool 70.60.0041 fit the oil seal as illustrated.

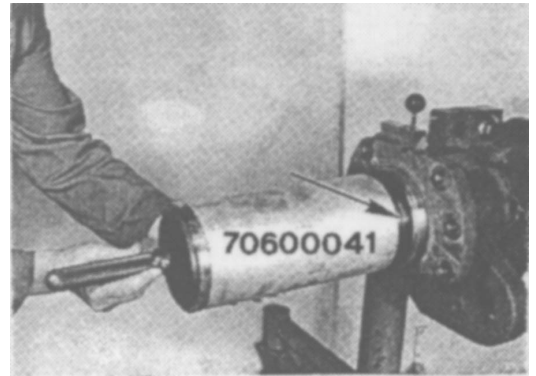

1. axle housing
2. dust ring
3. supporting ring
4. shaft seal
5. hub
6. brake anchor plate

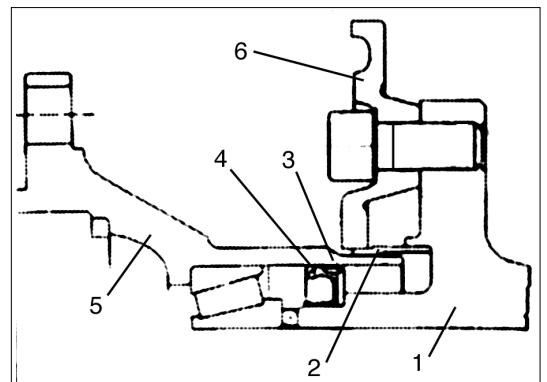

20

03

28

- Fit the brake plate (see specs at the end of this manual).

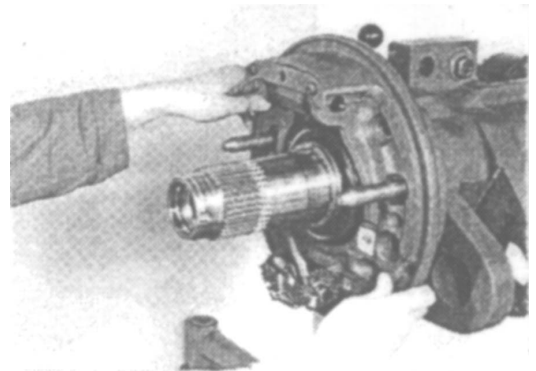

- Install the mounting capscrews :

 650 N·m (481 lbf·ft)

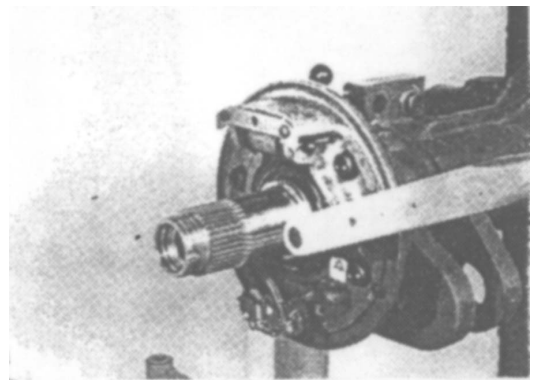

b FUNCTION

• Duo servo service brake

By application of the brake, brake shoe (3 – primary shoe) situated in front of the driving direction is pushed from its fulcrum by the hydraulic pressure, acting on wheel cylinder (2).

The supporting force (the frictional forces between the brake lining and brake drum) of the primary shoe resulting from the braking force is transmitted as actuating force to the opposite brake shoe (4 – secondary shoe) by the adjusting device –movable in both directions –(5 – figure B), after the initial stressing force of the compression spring, incorporated in adjuster (8 – Figure A), has been overcome.

The secondary shoe is supporting on the supporting bracket of the brake anchor plate (1).

In the case of vehicles without a preferred driving direction (e.g. fork lifts or construction machinery), springs (5) are centrally arranged.

In this case, the two brake shoes (3 + 4) are at first simultaneously moved from the supporting bracket. In the further course of the braking action, the corresponding brake shoe is then supporting, according to the driving direction, on the supporting bracket of brake anchor plate (1).

After the completed braking action, the brake shoes (3 + 4) return to the initial position, due to the return force of springs (5 + 6).

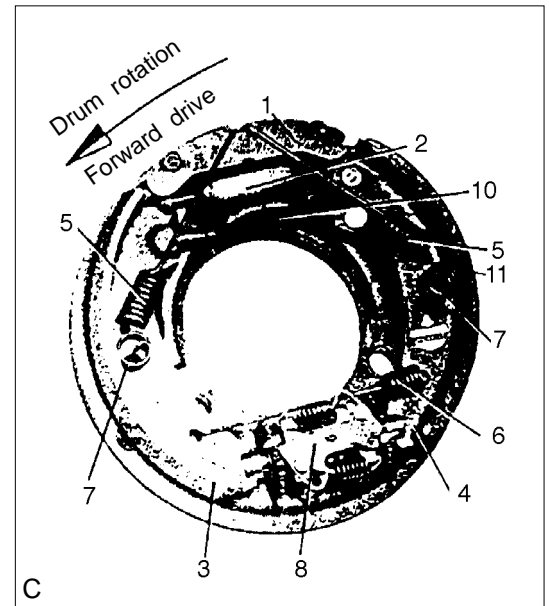

Fault	Possible cause	Remedy
Leakage at either input shaft, end cover, gerotor set, housing or ports.	<ul style="list-style-type: none"> • Shaft defective. • Screws loose. • Washers or O-rings defective. 	<ul style="list-style-type: none"> • Replace shaft seal, see service manual. • Tighten screws (3±0.3 kgf.m). • Replace washers or O-rings.

- Hold the outer part of the assembly tool in the bottom of the steering unit housing and guide the inner part of the tool completely to the bottom.



- Press and turn the O-ring/Kin-ring into position in the housing.

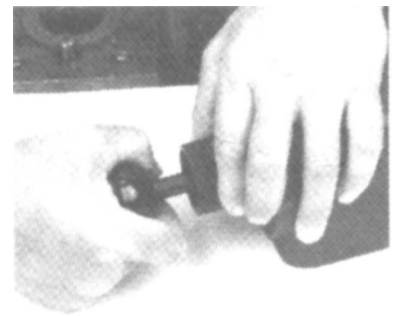

- Draw the inner and outer parts of the assembly tool out of the steering unit bore, leaving the guide from the inner part in the bore.

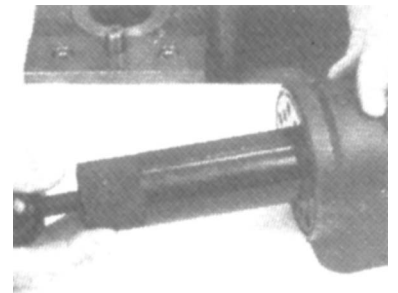

- With a light turning movement, guide the spool and sleeve into the bore.

- ⚠ **Fit the spool set holding the cross pin horizontal.**



30

02

10

ASSEMBLY

- Polish scratched or nicked machined surfaces with fine emery paper.



- Remove all burrs from the bushing bores with fine emery cloth.
Clean the parts with solvent and blow dry with compressed air.
Lightly lubricate all parts with hydraulic oil prior to assembling.



- Install the bushings in the end covers as follows :
 - Driving shaft bushing bores : the bushing groove must face the 12 O'clock position.
 - Driven shaft bushing bores : the bushing groove must face the 6 O'clock position.

**⚠ Always replace the bushings as a set.
New bushings must be installed when the gear set is replaced.**

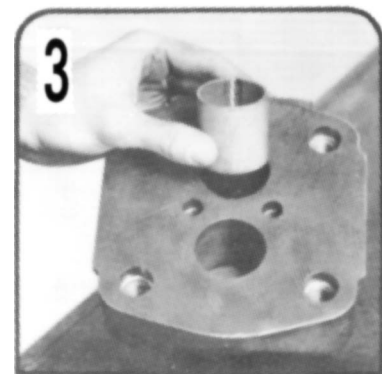

- Install the bushings using a press and a bushing mandrel.
Ensure that the bushings do not protrude above the machined surface.



50

01

3

INSPECTION AND ASSESSMENT

Each component should be thoroughly cleaned, carefully examined and assessed for suitability of re-use. Below is a guide for inspecting the various components.

GEAR HOUSING

- Inspect the body bore cut-in where both gears wipe into the body.

The body can only be re-used if the 'cut-in' is bright and polished in appearance and the depth does not exceed 0.18 mm (0.007 in).

If the length of the contact traces is a half of the internal length of the gear hole, it is normal.

The body should be inspected to ensure that there is no superficial damage which may adversely affect performance or sealing. Pay particular attention to the port threads and body 'O' ring seal recesses.

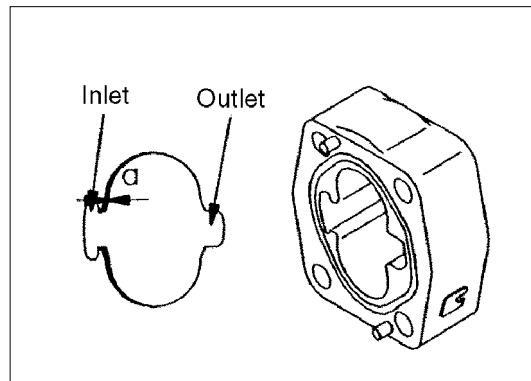

GEAR

- The gear teeth should be carefully examined to ensure that there are no signs of bruising, pitting or that a wear step can be felt.

The journal bearing surfaces should be completely free from scoring or bruising. The surface should appear highly polished and smooth to touch.

Gear set should be changed if the ϕd size is below $\phi 23.887$.

Examine the area where the shaft seal lips run on the drive shaft, this shows up as a polished ring or rings. If a noticeable groove can be felt or there is scoring the shaft should be replaced.

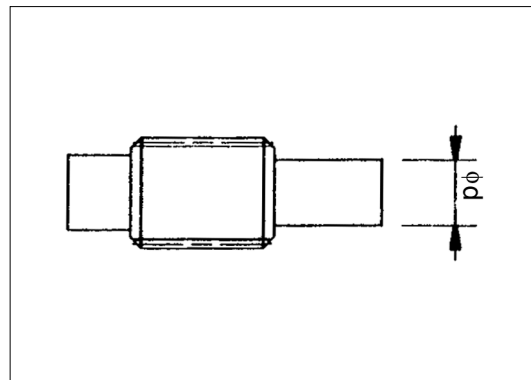

THRUST PLATE

- The surface of the thrust plate is coated with a gray colored Teflon. In normal operation, a soft trace is left at the point of gear contact as shown in the figure.

A regular trace is not a problem, but any irregular scratch or roughness felt by rubbing with a finger nail, or if the thickness is less than 4.894 mm (0.1927 in), the plate should be replaced.

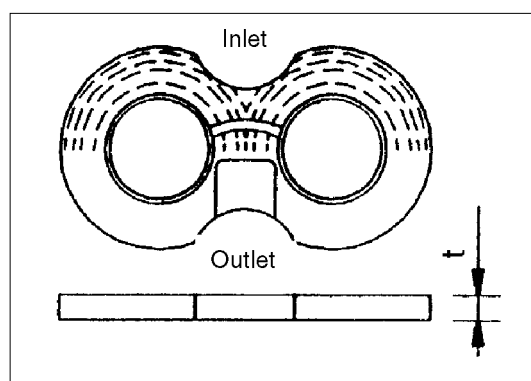

HYDRAULIC CYLINDERS

LIFT CYLINDER

DISASSEMBLY

Prior to disassembly, thoroughly clean the exterior of the cylinder.

Remove the hydraulic oil from the cylinder by stroking the piston rod to force the oil out.

When overhauling the cylinder, ensure that contamination does not enter the cylinder. The smallest particles are capable of severely damaging the hydraulic system.

- Hold the cylinder securely in a vise, do not use excessive force.

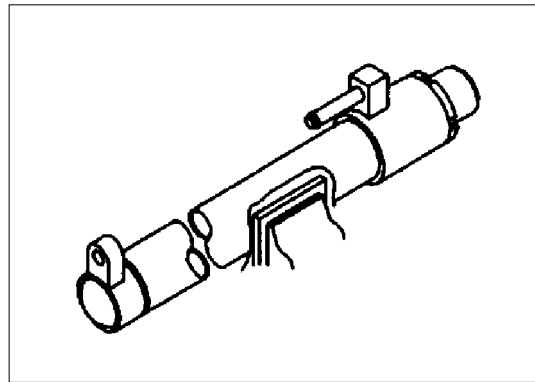

- Remove the gland with a hook wrench. Carefully pull the gland assembly from the cylinder tube and slide it off the cylinder rod.

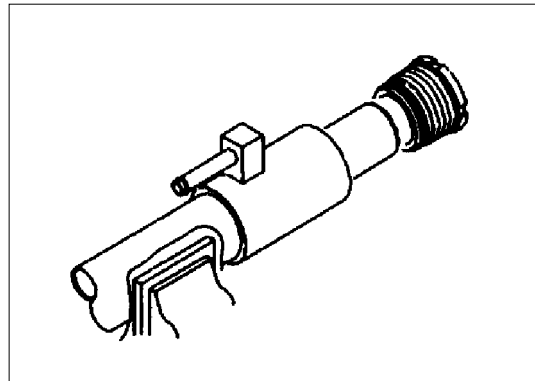

- After the gland is removed, pull the piston rod assembly from the cylinder barrel.

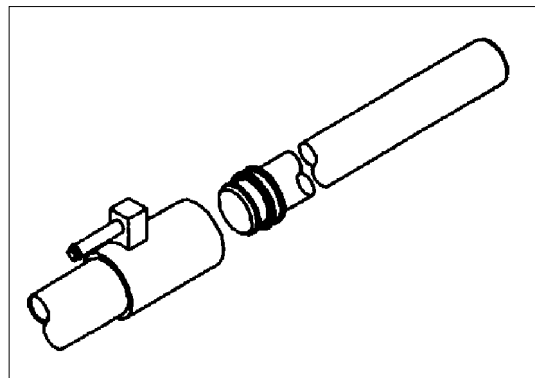

W SERIES GEAR PUMP

DOUBLE PUMP (1500 SERIES SHOWN)

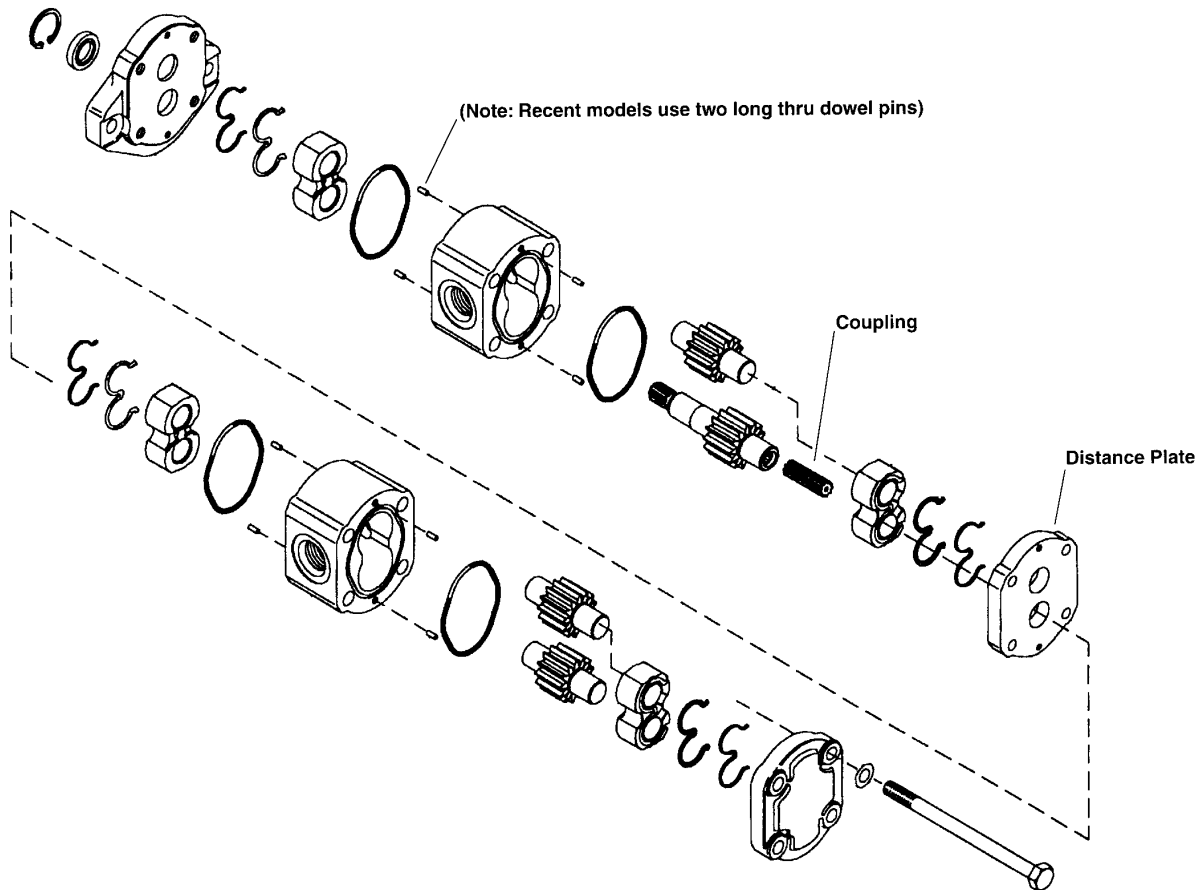

20. The name plate located on the end cover contains the build date code and the model number. Please refer to this information when corresponding with the J. S. Barnes Service Department.

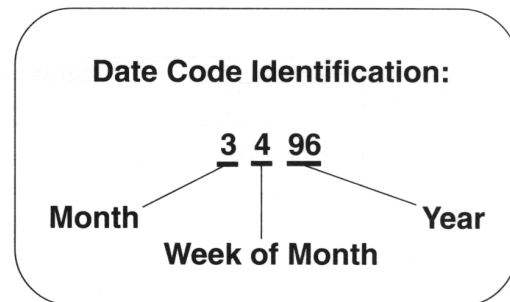
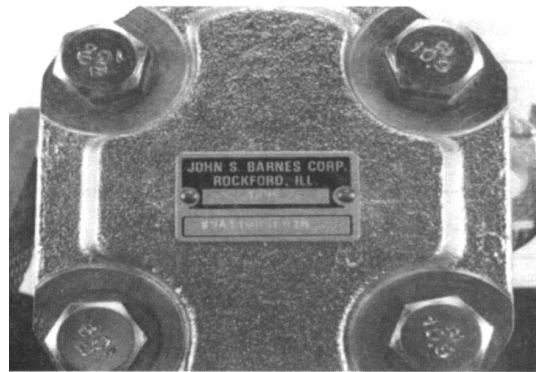

PLACING PUMP BACK INTO SERVICE

1. **If shop test stand is available**, the following procedure for testing rebuilt pumps is recommended :
 - A. Mount pump on test stand making sure that the proper level of clean oil is available in the reservoir. Check suction line for leaks and obstructions.
 - B. Start pump and run for three minutes at zero pressure.
 - C. Intermittently load pump to 500 P.S.I. for three minutes.
 - D. Intermittently load pump to 1000 P.S.I. for three minutes.
 - E. Intermittently load pump to 2000 P.S.I. for three minutes.
 - F. Remove pump from test stand and check for freeness of drive shaft. Check pump for signs of external leakage.

2. **If shop test stand is not available**, the following procedure for testing rebuilt pumps is recommended :
 - A. For engine driven pumps, mount pump on equipment and run pump at 1/2 engine speed at zero pressure for three minutes.
 - B. By operating control valve, build pressure intermittently for three minutes.

CLICK HERE TO **DOWNLOAD** THE COMPLETE MANUAL

- Thank you very much for reading the preview of the manual.
- You can download the complete manual from: www.heydownloads.com by clicking the link below



- Please note: If there is no response to CLICKING the link, please download this PDF first and then click on it.

CLICK HERE TO **DOWNLOAD** THE COMPLETE MANUAL