

# **CLAAS**

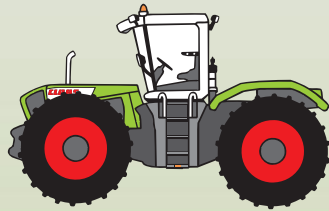

**XERION 3300 (up to serial no. 109)**

## **Technical Systems Electric System**

***SERVICE & PARTS***

CLICK HERE TO **DOWNLOAD** THE COMPLETE MANUAL

- Thank you very much for reading the preview of the manual.
- You can download the complete manual from: [www.heydownloads.com](http://www.heydownloads.com) by clicking the link below



- Please note: If there is no response to CLICKING the link, please download this PDF first and then click on it.

CLICK HERE TO **DOWNLOAD** THE COMPLETE MANUAL

<b>43a Trailer brake</b> .....	<b>389</b>
Circuit diagram (DIN A3) .....	390
Key to diagram .....	391
Measuring value table .....	392
Description of function .....	392
Diagnosis table 43 .....	393
Connector pin assignment .....	393
Interconnection list .....	393
<b>44a Transmission control</b> .....	<b>395</b>
Circuit diagram up to serial no. 50 (DIN A 3) .....	396
Key to diagram .....	397
Measuring value table .....	398
Description of function .....	398
Diagnosis table 44 .....	399
Connector pin assignment .....	401
Interconnection list .....	401
<b>44b Transmission control</b> .....	<b>403</b>
Circuit diagram from serial no. 51 (DIN A 3) .....	404
Key to diagram .....	405
Measuring value table .....	406
Description of function .....	406
Diagnosis table 44 .....	407
Connector pin assignment .....	409
Interconnection list .....	409
<b>45a Lighting main circuit, taillight, position light</b> .....	<b>411</b>
Circuit diagram (DIN A3) .....	412
Key to diagram .....	413
Description of function .....	413
Connector pin assignment .....	414
Interconnection list .....	414
<b>46a Low beam, high beam, low beam changeover switch</b> .....	<b>415</b>
Circuit diagram (DIN A3) .....	416
Key to diagram .....	417
Description of function .....	418
Connector pin assignment .....	418
Interconnection list .....	418
<b>47a Worklights I</b> .....	<b>421</b>
Circuit diagram up to serial no. 50 (DIN A 3) .....	422
Key to diagram .....	423
Description of function .....	424
Connector pin assignment .....	424
Interconnection list .....	424
<b>47b Worklights I</b> .....	<b>425</b>
Circuit diagram from serial no. 51 (DIN A 3) .....	426
Key to diagram .....	427
Description of function .....	428
Connector pin assignment .....	428
Interconnection list .....	428

Item	Fuse		Circuit diagram no.							
F14	CEBIS diagnosis socket	7.5A	6	-	-	-	-	-	-	-
F15	Relay 15a/b	3A	1	6	28	-	-	-	-	-
F16	Alternator charging light	7.5A	3	-	-	-	-	-	-	-
F17	Motor 50a	7.5A	1	-	-	-	-	-	-	-
F18	not used	3A	-	-	-	-	-	-	-	-
F19	Transmission control (battery plus)	7.5A	6	44	-	-	-	-	-	-
F20	Transmission control, load	7.5A	7	41	42	44	-	-	-	-
F21	Monitor +	7.5A	5	6	-	-	-	-	-	-
F22	Electronic lift control (EHR), (battery plus)	10A	6	-	-	-	-	-	-	-
F27	Radar	10A	2	6	41	-	-	-	-	-
F29	Fuse test	-	1	-	-	-	-	-	-	-
F30	Ignition switch	30A	1	-	-	-	-	-	-	-
F31	12V trailer socket	15A	30	-	-	-	-	-	-	-
F32	12V cab socket	25A	40	-	-	-	-	-	-	-
F33	3-pin cab socket	30A	40	-	-	-	-	-	-	-
F34	3-pin socket front / rear	30A	40	-	-	-	-	-	-	-
F35	Autopilot+ socket	10A	13	-	-	-	-	-	-	-
F36	Additional 7-pin / 9-pin socket	3A	6	10	-	-	-	-	-	-
F37	CLAAS diagnosis socket	3A	-	-	-	-	-	-	-	-
F38	Engine diagnosis socket	3A	2	-	-	-	-	-	-	-
F39	Additional control terminal socket	10A	13	-	-	-	-	-	-	-
F40	Additional control terminal socket	25A	13	-	-	-	-	-	-	-
F41	Tail ISO socket - Central terminal compartment (electronics)	25A	6	10	-	-	-	-	-	-
F42	Front ISO socket - Central terminal compartment (electronics)	25A	6	10	-	-	-	-	-	-
F43	ISO signal socket, (battery plus)	3A	6	10	-	-	-	-	-	-
F45	Brake pressure contact	3A	41	-	-	-	-	-	-	-
F46	Brake pedal contact	3A	41	-	-	-	-	-	-	-
F47	Special function	7.5A	-	-	-	-	-	-	-	-
F48	Special function	20A	-	-	-	-	-	-	-	-

**Relay**

Item	Relay	Circuit diagram no.							
		1	-	-	-	-	-	-	-
K1	15a	1	-	-	-	-	-	-	-
K2	15b	1	-	-	-	-	-	-	-
K3	Front ISO power relay	10	-	-	-	-	-	-	-
K4	Tail ISO power relay	10	-	-	-	-	-	-	-
K5	Tail worklight / external	47	-	-	-	-	-	-	-
K6	External power relay	13	-	-	-	-	-	-	-
K7	Power relay power supply	6	-	-	-	-	-	-	-
K8	EHL power relay	28	-	-	-	-	-	-	-
K9	Switching-over	28	-	-	-	-	-	-	-
K10	Switching-over	28	-	-	-	-	-	-	-
K11	Unlock cab	33	-	-	-	-	-	-	-
K12	Constant-pressure valve	4	-	-	-	-	-	-	-
K13	Floating axle lock	31	-	-	-	-	-	-	-
K14	Transport mode	13	-	-	-	-	-	-	-
K15	Air conditioning compressor	38	-	-	-	-	-	-	-
K16	Spare	-	-	-	-	-	-	-	-
K17	Soft brake enable	41	-	-	-	-	-	-	-
K18	Back-up light	49	-	-	-	-	-	-	-
K19	Rear wheel position indicator 1, external	13	-	-	-	-	-	-	-
K20	Rear wheel position indicator 2, external	13	-	-	-	-	-	-	-
K21	High beam	46	-	-	-	-	-	-	-
K22	Low beam	46	-	-	-	-	-	-	-
K23	Brake light	41	-	-	-	-	-	-	-
K24	Parking brake	41	-	-	-	-	-	-	-
K25	Roof top worklights	47	-	-	-	-	-	-	-
K26	Roof outside worklights	47	-	-	-	-	-	-	-
K27	Roof inside worklights	47	-	-	-	-	-	-	-
K28	Mirror holder worklights	47	-	-	-	-	-	-	-
K29	Dipped headlights bracket worklight	47	-	-	-	-	-	-	-
K30	Reverse outside worklight	48	-	-	-	-	-	-	-
K31	Reverse centre worklight	48	-	-	-	-	-	-	-
K32	Reverse inside worklight	48	-	-	-	-	-	-	-

**Module A15 - Electronic engine control CAT**

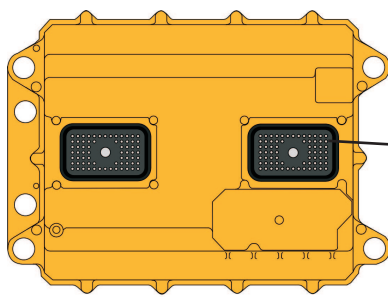

401261

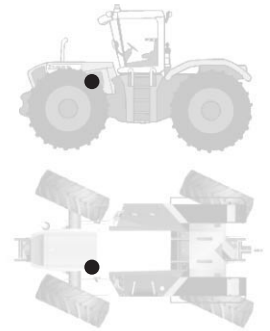
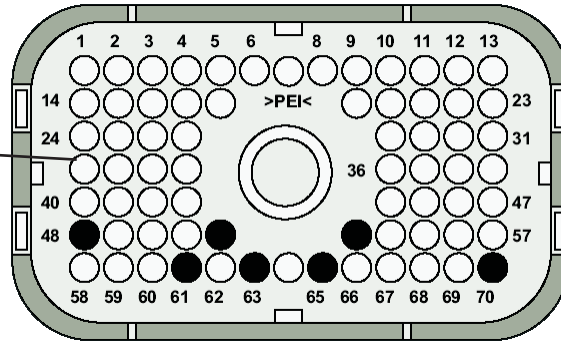

Pin	Function	CCN	Component	Circuit diagram	Measuring variable	Direction
34	CAN 2 low (J1939)	-	-	6	2.2 - 2.7Veff	-
42	CAN 2 screen (J1939)	-	-	2	-	-
44	Enable diagnosis LED	U22	Diesel engine diagnosis switch	2	Ground	Input
48	Power plus 30	F01	Fuse	2, 6	12V	Input
50	CAN 2 high (J1939)	-	-	2	2.4 - 2.9Veff	-
52	Power plus 30	F01	Fuse	2, 6	12V	Input
53	Power plus 30	F01	Fuse	2, 6	12V	Input
54	Coolant level signal	Z33	Coolant level switch	2	0V	Input
61	Ground	-31	Vehicle ground	2, 6	Ground	Input
63	Ground	-31	Vehicle ground	2, 6	Ground	Input
64	Electric starting motor starting mode (terminal 50)	F17	Fuse	1, 2	12V	Input
65	Ground	-31	Vehicle ground	2, 6	Ground	Input
66	Ground drive pedal signal 1	B153	Ground drive pedal sensor	41	PWM	Input

**Module A55 electrohydraulic steering (EHL) connector X1, from serial no. 51**

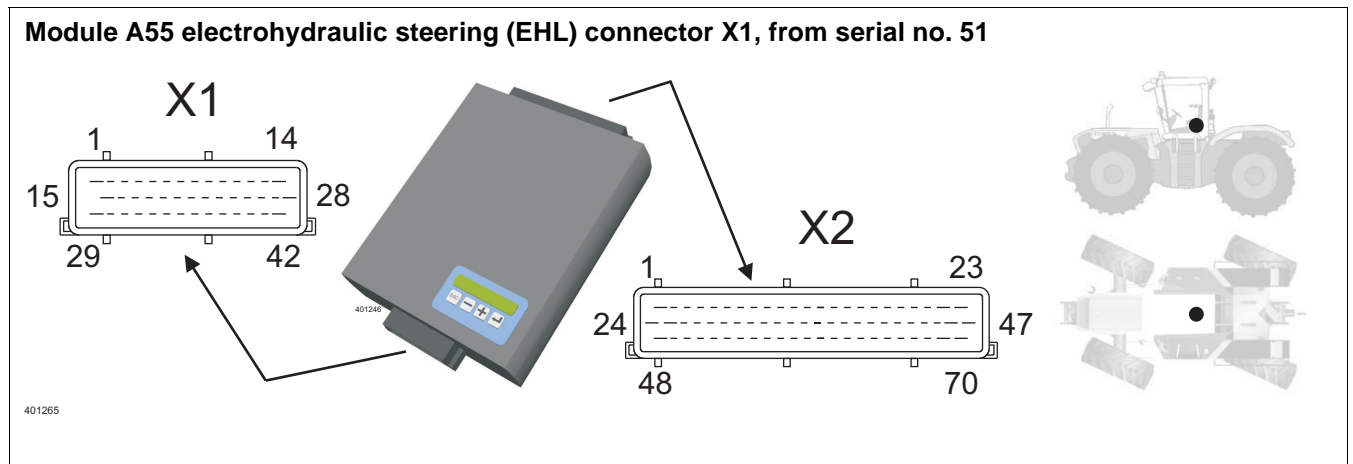

Pin	Function	CCN	Component	Circuit diagram	Measuring variable	Direction
1	Joystick_ri -	S108	Steering position right offset switch	28b	0/12V	Input
2	Joystick_ri +	S108	Steering position right offset switch	28b	12/0V	Input
3	Joystick_le -	S107	Steering position left offset switch	28b	0/12V	Input
4	Joystick_le +	S107	Steering position left offset switch	28b	12/0V	Input
5	not used	-	-	-	-	-
6	"Hydraulic system/road travel" main switch	S52	Road travel switch (red)	4a	0/12V	Input
7	not used	-	-	-	-	-
8	Wheel pump (pressure switch Z103)	Z103	Pump function actual value switch	28b	0/12V	Input
9	not used	-	-	-	-	-
10	not used	-	-	-	-	-
11	not used	-	-	-	-	-
12	not used	-	-	-	-	-
13	not used	-	-	-	-	-
14	not used	-	-	-	-	-
15	U_Ref (5V) ext (not used)	-	-	-	5V	Output
16	not used	-	-	-	-	-
17	not used	-	-	-	-	-
18	not used	-	-	-	-	-
19	not used	-	-	-	-	-
20	not used	-	-	-	-	-

**Module A56 - VDC (Vehicle drive control)**

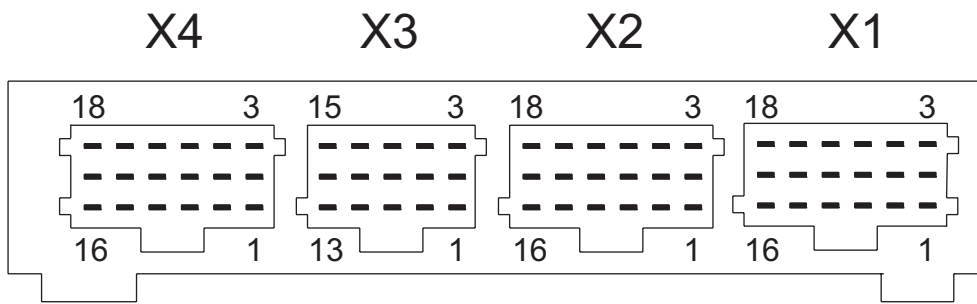

401266

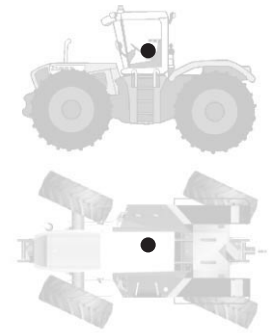

Pin	Function	CCN	Component	Circuit diagram	Measuring variable	Direction
2/13	Brake pedal	Z81	Brake pressure actual value switch Service brake	41a, 41b	T. signal approx. 6Volt eff	Input
2/14	Brake pressure / light	B148	Brake sensor actuated	41a, 41b	Low - high	Input
2/15	not used	-	-	-	-	-
2/16	Neutral	S93	Parking brake switch	41a, 41b	0/12V	Input
2/17	Seat contact	Z5	Seat contact switch	41a, 41b	0/12V	Input
2/18	not used	-	-	-	-	-
-	-	-	-	-	-	-
3/1	Veh._Can GND	-	-	-	-	-
3/2	Veh._Can L	-	-	6a, 6b	3.2±0.2 Volt eff	-
3/3	Veh._Can H	-	-	6a, 6b	1.9±0.2 Volt eff	-
3/4	not used	-	-	-	-	-
3/5	Parking brake	K17	Relay	41a, 41b	12V	Output
3/6	PTO_II	Y199-2	Solenoid coil Drive clutch	8a, 8b	12V	Output
3/7	not used	-	-	-	-	-
3/8	Centre differential	Y105-1	Solenoid coil Differential lock	32a, 32b	12V	Output
3/9	PTO_1	Y199-1	Solenoid coil Drive clutch	7a, 7b	PWM	Output

**Module A59-1 Valve control (VCU)**

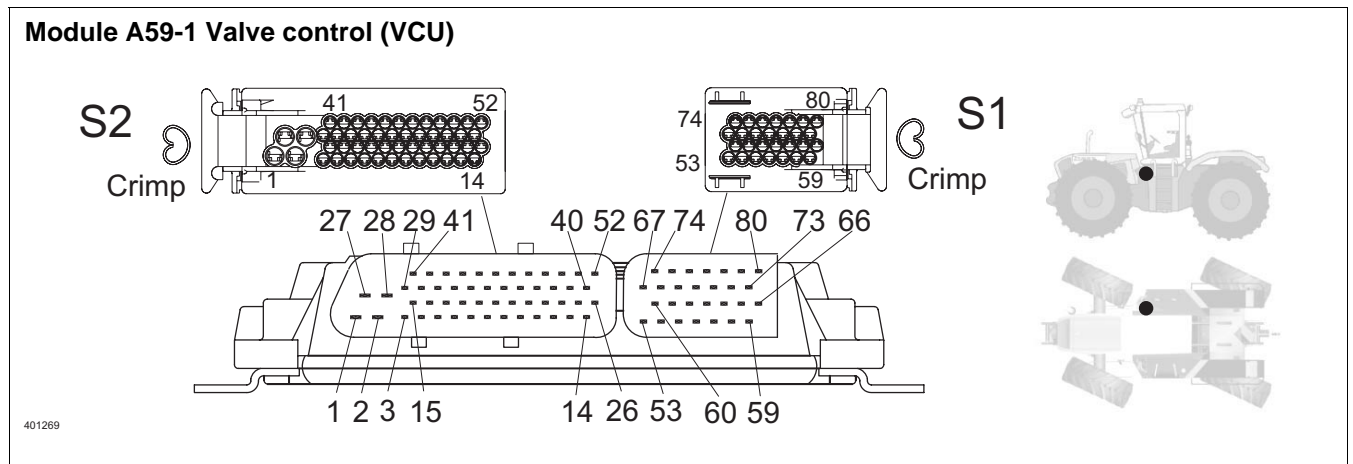

Pin	Function	CCN	Component	Circuit diagram	Measuring variable	Direction
1	Power outputs power supply	F05	Fuse	6a, 6b, 22a, 23a	12V	Input
2	Ground	-31	-31	6a, 6b	0V	Input
4	Red control valve, connection A	Y198-1a	Solenoid coil Pilot valve (red A)	22a, 23a	PWM	Output
11	Coding 1	-31	-31	6a, 6b	0V	Input
13	Output stages enable	F05	Fuse	6a, 6b	12V	Input
16	Red control valve, connection B	Y198-1b	Solenoid coil Pilot valve (red B)	22a, 23a	PWM	Output
23	Coding 2	F05	Fuse	6a, 6b	12V	Input
25	CAN 2 Low	-	-	6a, 6b	# Volt eff	-
26	CAN 2 High	-	-	6a, 6b	# Volt eff	-
27	Power outputs power supply	F05	Fuse	6a, 6b	12V	Input
28	Ground	-31	-31	6a, 6b	0V	Input
30	White control valve, connection B	Y198-3b	Solenoid coil Pilot valve (white B)	20a	PWM	Output
31	White control valve, connection A	Y198-3a	Solenoid coil Pilot valve (white A)	20a	PWM	Output
38	CAN screen / GND	-	-	-	-	-
39	CAN 1 Low	-	-	6a, 6b	# Volt eff	-
40	CAN 1 High	-	-	6a, 6b	# Volt eff	-
41	Electronics power supply	F05	Fuse	6a, 6b	12V	Input

**Module A61 - Fieldwork computer XERION (XIF)**

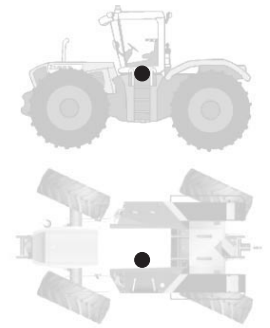
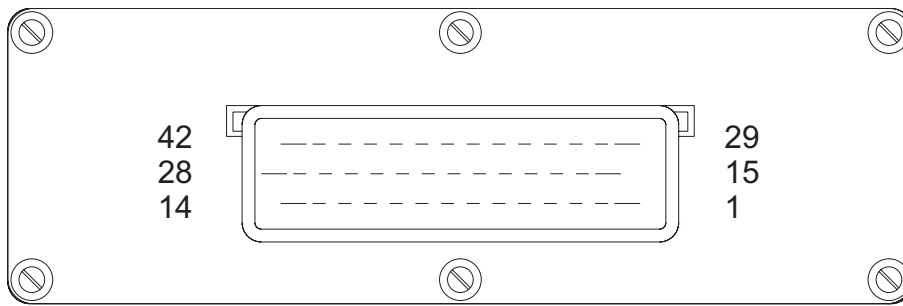

401264

Pin	Function	CCN	Component	Circuit diagram	Measuring variable	Direction
19	External tail PTO shaft inverse switch	U30-2	External switch Tail PTO On/Off	7a, 7b	see external switch table	Input
20	Electronic throttle Off rocker switch	S115	Switch Engine speed set / reset electronic throttle	2a, 2b	see electronic throttle table	Input
21	Electronic throttle shaft encoder, signal A	B154	Sensor Electronic throttle engine speed set value	2a, 2b	0 or 5V, alternatingly	Input
22	Not used	-	-	-	-	Input
23	Ignition lock, ignition On/Off	F15	Fuse	01a, 01b	Off = 0V On = 12V	Input
24	Cross differential lock switch	S94	Switch Differential lock (cross)	32a, 32b	T. signal approx. 6Volt eff	Input
25	Not used (never use as a connection)	-	-	-	-	-
26	Reference voltage Uref	-	-	2a, 2b, 13	5V	Output
27	Can-J1939 high, CAN2_H	-	-	6a, 6b	2.4 - 2.9Veff	-
28	Terminal 31	-31	-31	6a, 6b	Ground	Input
29	T signal (clock signal) for XIF module	-	-	2a, 2b, 7a, 7b, 8a, 8b, 32a, 32b, 33a	T. signal approx. 6Volt eff	Output

**Key to diagram**







Item	Component	Co-ordinates
A61	XIF module	6-k-19
-	-	-
D1	Fuse test LED	6-k-19
-	-	-
G1-1	Battery 1	8-j-17
G1-2	Battery 2	8-j-17
G2-1	Left alternator	6-f-20
G2-2	Right alternator	6-f-19
-	-	-
K01	Relay 15a	6-k-19
K02	Relay 15b	6-k-19
K45	VDC / TCU power relay	6-k-19
-	-	-
M21	Electric starter motor	8-h-20
-	-	-
S64	Ignition switch	5-j-19
-	-	-
U21	Battery isolating switch	8-k-17

**Description of function**

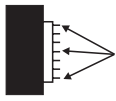
Starting The ignition switch (S64) switches the diesel engine electric starting motor (M21) with +50a.

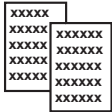
Electronic plus circuit During starting, the potential at pin 85 of relay (K45) changes. Relay (K45) cuts off the electronic plus supply of some modules during starting. This avoids an undervoltage of the modules during starting which would be identified as an electronics fault.

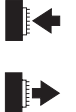









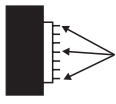

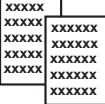





**Diagnosis table 1**

Module A61 XIF						
Module pin	CCN	Description	Measuring variable set value	Measuring variable actual value	Direction	Circuit diagram
						
23	F15	Ignition	12 Volt	CDSCDS		1

**Electronic throttle switching logics**

Function	Module A61 XIF Pin 20	Module A61 XIF Pin 6
Switch S115 neutral	T signal 6 Volt <sub>eff</sub>	0
Electronic throttle ON - Set	0	T signal 6 Volt <sub>eff</sub>
Electronic throttle OFF - Reset	0	0
Fault / DTC 6190	T signal 6 Volt <sub>eff</sub>	T signal 6 Volt <sub>eff</sub>

**Diagnosis table 2**

Module A15 Electronic engine control						
Module pin	CCN	Description	Measuring variable set value	Measuring variable actual value	Direction	Circuit diagram
						
5	-	PWM reference	0 Volt	CDS		2, 41
8	XM	Engine diagnosis	---	---	---	2
9	XM	Engine diagnosis	---	---	---	2
28	D02	Diagnosis LED	---	---		only 2a
44	U22	Diesel engine diagnosis switch	Ground	---		2
48	F01	Battery plus 30	12 Volt	CDS		2, 6
52	F01	Battery plus 30	12 Volt	CDS		2, 6
53	F01	Battery plus 30	12 Volt	CDS		2, 6
54	Z33	Coolant level	0 Volt	CDS		2
61	-31	Vehicle ground 31	Ground	CDS		2, 6
63	-31	Vehicle ground 31	Ground	CDS		2, 6
64	F17	Starting mode	12 Volt	CDS		1,2
65	-31	Vehicle ground 31	Ground	CDS		2, 6
70	F02	Ignition plus 15	12 Volt	CDS		2

**Connector pin assignment**



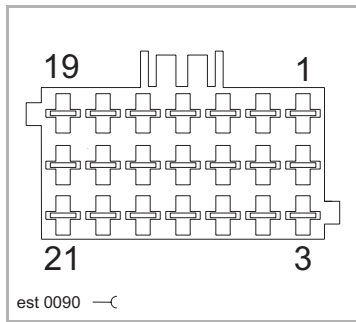





Socket DI, LD

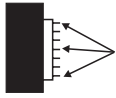

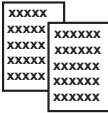







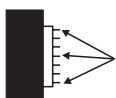

**Interconnection list**

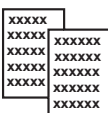
from	to 1	to 2	to 3	to 4	to 5	mm <sup>2</sup>	Colour
DI - 4	DM D	-	-	-	-	0.75	bl-or
DI - 5	DM E	-	-	-	-	0.75	bl-gn
DI - 6	LA -14	-	-	-	-	0.75	gr-vio
DI - 7	DK - 1	-	-	-	-	0.75	bl-bk
DI - 8	K16/87a	-	-	-	-	0.75	-
DI - 9	K16/87	-	-	-	-	-	-
DI - 13	F01a	DI - 14	DI - 15	-	-	2.5	rd
DI - 14	F01a	DI - 13	DI - 15	-	-	2.5	rd
DI - 15	F01a	DI - 14	DI - 13	-	-	2.5	rd
DI - 16	31	-	-	-	-	2.5	br
DI - 17	31	-	-	-	-	2.5	br
DI - 18	31	-	-	-	-	2.5	br
DI - 20	F02a	-	-	-	-	0.75	bk
-	-	-	-	-	-	-	-
LD - 3	31	-	-	-	-	0.75	gr
LD - 6	XIF-35	-	-	-	-	0.75	wh-br
LD - 7	XIF-21	-	-	-	-	0.75	wt-rd
LD - 8	XIF-26	DF-16	JW- 8	-	-	0.75	wh-or
LD - 9	XIF-6	-	-	-	-	0.75	wh-ye
LD - 10	XIF-20	-	-	-	-	0.75	wh-gn
LD - 11	XIF-29	LC-6	RE -4	-	-	0.75	wh-bl

Diagnosis table 4

Module A55 Electrohydraulic steering (EHL) connector X1						
Module pin	CCN	Description	Measuring variable set value	Measuring variable actual value	Direction	Circuit diagram
						
X1/06	S52	Road travel switch	T signal6 Volt <sub>eff</sub>	CDS		4

Module A60 HYD						
Module pin	CCN	Description	Measuring variable set value	Measuring variable actual value	Direction	Circuit diagram
						
1	F05	Plus supply	12 Volt	CDS		4, 20, 21, 22, 26
17	S52	Road travel switch	T signal6 Volt <sub>eff</sub>	CDS		4
29	-	Hyd module clock signal	T signal6 Volt <sub>eff</sub>	CDS		4, 20, 26

**Measured value table 250 kB vehicle CAN bus (Vehicle CAN bus)**

CAN-high (U <sub>eff</sub> )	CAN-low (U <sub>eff</sub> )	Diagnosis
1.9±0.2V <sub>eff</sub>	3.2±0.2 Volt <sub>eff</sub>	System OK
approx. 2.5V <sub>eff</sub>	approx. 2.5V <sub>eff</sub>	Short-circuit CAN-high against CAN-low
approx. 1.9V <sub>eff</sub>	>3.2 Volt <sub>eff</sub>	Short-circuit CAN-low against +12 Volt
approx. 2.5V <sub>eff</sub>	<3.2 Volt <sub>eff</sub>	Short-circuit CAN-low against ground
>1.9 Volt <sub>eff</sub>	approx. 3.2V <sub>eff</sub>	Short-circuit CAN-high against +12 Volt
<1.9 Volt <sub>eff</sub>	approx. 3.2V <sub>eff</sub>	Short-circuit CAN-high against ground

**Measured value table 250 kB CAN bus hydraulic system**

CAN-high (U <sub>eff</sub> )	CAN-low (U <sub>eff</sub> )	Diagnosis
#±0.2V <sub>eff</sub>	#±0.2V <sub>eff</sub>	System OK
approx. 2.5V <sub>eff</sub>	approx. 2.5V <sub>eff</sub>	Short-circuit CAN-high against CAN-low
approx. # Volt <sub>eff</sub>	>5 Volt <sub>eff</sub>	Short-circuit CAN-low against +12 Volt
approx. # Volt <sub>eff</sub>	<1 Volt <sub>eff</sub>	Short-circuit CAN-low against +ground
>5 Volt <sub>eff</sub>	approx. # Volt <sub>eff</sub>	Short-circuit CAN-high against +12 Volt
<1.0 Volt <sub>eff</sub>	approx. # Volt <sub>eff</sub>	Short-circuit CAN-high against ground

**Measured value table J1939 CAN bus**

CAN-high (U <sub>eff</sub> )	CAN-low (U <sub>eff</sub> )	Diagnosis
2.4+0.5V <sub>eff</sub>	2.2+0.5V <sub>eff</sub>	System OK
approx. 2.5V <sub>eff</sub>	approx. 2.5V <sub>eff</sub>	Short-circuit CAN-high against CAN-low
2.4+0.5V <sub>eff</sub>	>5 Volt <sub>eff</sub>	Short-circuit CAN-low against +12 Volt
2.4+0.5V <sub>eff</sub>	<1 Volt <sub>eff</sub>	Short-circuit CAN-low against ground
>5 Volt <sub>eff</sub>	2.2+0.5V <sub>eff</sub>	Short-circuit CAN-high against +12 Volt
<1 Volt <sub>eff</sub>	2.2+0.5V <sub>eff</sub>	Short-circuit CAN-high against ground

**Measured value table ISO 11783 CAN bus**

CAN-high (U <sub>eff</sub> )	CAN-low (U <sub>eff</sub> )	Diagnosis
2.52±0.1 Volt <sub>eff</sub>	2.49±0.1 Volt <sub>eff</sub>	System OK
approx. 2.5V <sub>eff</sub>	approx. 2.5V <sub>eff</sub>	Short-circuit CAN-high against CAN-low
>2.5 Volt <sub>eff</sub>	>5 Volt <sub>eff</sub>	Short-circuit CAN-low against +12 Volt
<2.3 Volt <sub>eff</sub>	<1 Volt <sub>eff</sub>	Short-circuit CAN-low against ground
>5 Volt <sub>eff</sub>	>2.5 Volt <sub>eff</sub>	Short-circuit CAN-high against +12 Volt
<1 Volt <sub>eff</sub>	<2.3 Volt <sub>eff</sub>	Short-circuit CAN-high against ground

**CAN bus network**

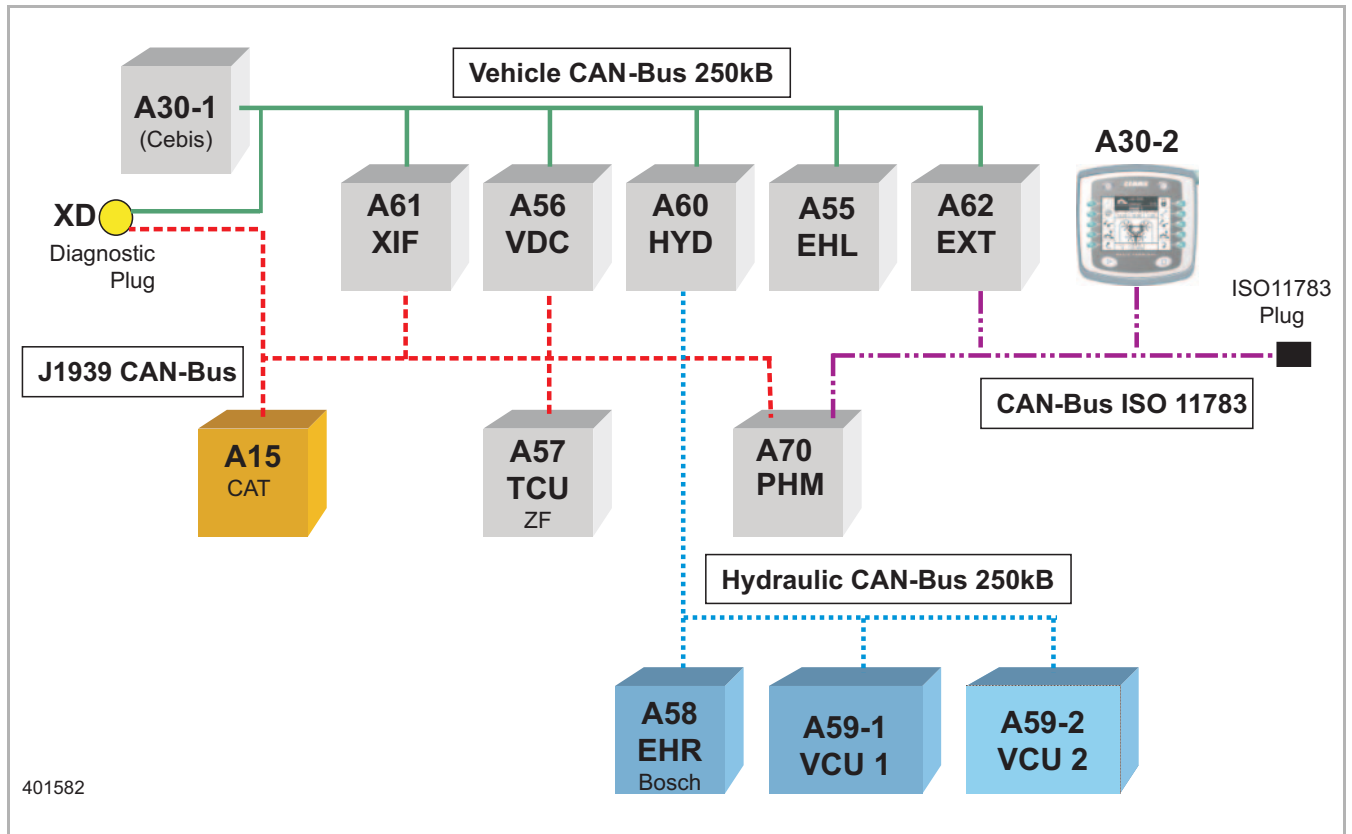

401582

**Measured value table 250 kB vehicle CAN bus (Vehicle CAN bus)**

CAN-high (U <sub>eff</sub> )	CAN-low (U <sub>eff</sub> )	Diagnosis
1.9±0.2Volt <sub>eff</sub>	3.2±0.2 Volt <sub>eff</sub>	System OK
approx. 2.5Volt <sub>eff</sub>	approx. 2.5Volt <sub>eff</sub>	Short-circuit CAN-high against CAN-low
approx. 1.9Volt <sub>eff</sub>	>3.2 Volt <sub>eff</sub>	Short-circuit CAN-low against +12 Volt
approx. 2.5Volt <sub>eff</sub>	<3.2 Volt <sub>eff</sub>	Short-circuit CAN-low against ground
>1.9 Volt <sub>eff</sub>	approx. 3.2Volt <sub>eff</sub>	Short-circuit CAN-high against +12 Volt
<1.9 Volt <sub>eff</sub>	approx. 3.2Volt <sub>eff</sub>	Short-circuit CAN-high against ground

**Measured value table 250 kB CAN bus hydraulic system**

CAN-high (U <sub>eff</sub> )	CAN-low (U <sub>eff</sub> )	Diagnosis
#±0.2Volt <sub>eff</sub>	#±0.2Volt <sub>eff</sub>	System OK
approx. 2.5Volt <sub>eff</sub>	approx. 2.5Volt <sub>eff</sub>	Short-circuit CAN-high against CAN-low
approx. # Volt <sub>eff</sub>	>5 Volt <sub>eff</sub>	Short-circuit CAN-low against +12 Volt
approx. # Volt <sub>eff</sub>	<1 Volt <sub>eff</sub>	Short-circuit CAN-low against +ground
>5 Volt <sub>eff</sub>	approx. # Volt <sub>eff</sub>	Short-circuit CAN-high against +12 Volt
<1.0 Volt <sub>eff</sub>	approx. # Volt <sub>eff</sub>	Short-circuit CAN-high against ground

**Logics table: Rear PTO switch S114 (internal, in cab)**

Function	Module A61 XIF Pin 18	Module A61 XIF Pin 17
Switch S114 neutral	T signal 6 Volt <sub>eff</sub>	0
Rear PTO ON	0	T signal 6 Volt <sub>eff</sub>
Rear PTO OFF	0	0
Fault / DTC 6187	T signal 6 Volt <sub>eff</sub>	T signal 6 Volt <sub>eff</sub>

**Logics table: Rear PTO switch U30 (external, on mud guard)**

Function	Module A61 XIF Pin 33	Module A61 XIF Pin 19
Switch U30 not actuated	0	T signal 6 Volt <sub>eff</sub>
Switch U30 actuated	T signal 6 Volt <sub>eff</sub>	0
Fault / DTC 6188	0	0
Fault / DTC 6188	T signal 6 Volt <sub>eff</sub>	T signal 6 Volt <sub>eff</sub>

**Diagnosis table 7**

Module A56 VDC		
Status/operating status	CDS display target value	CDS display actual value
PTO1 ON	PTO1 on	x
PTO1 OFF	PTO1 off	x

Module A56 VDC						
Module pin	CCN	Description	Measuring variable set value	Measuring variable actual value	Direction	Circuit diagram
X3/09	Y199-1	PTO1 ON	PWM	CDS		7
X3/11	B142	PTO1 speed	Frequency	CDS		7
X3/14	F03	Power supply plus	12 Volt	CDS		6, 7

**Connector pin assignment**

Socket, LD, RE, RH

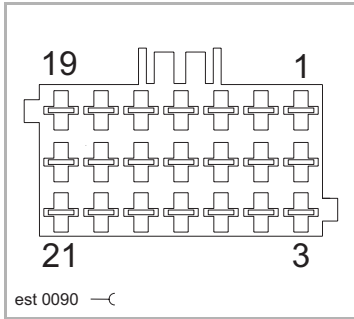

Socket RL

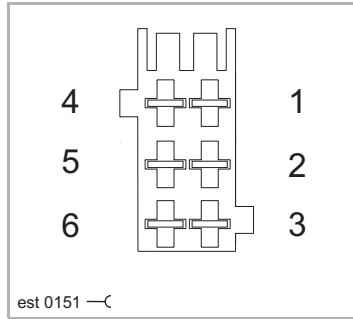

**Interconnection list**

from	to 1	to 2	to 3	to 4	to 5	mm <sup>2</sup>	Colour
LD 11	XIF 29	LC 6	RE 4	-	-	0.75	wh/bl
LD 12	XIF 18	-	-	-	-	0.75	wh/vi
LD 13	XIF 17	-	-	-	-	0.75	wh/gr
-	-	-	-	-	-	-	-
RE 2	XIF 19	-	-	-	-	0.75	wh/bl
RE 3	XIF 33	-	-	-	-	0.75	wh/gn
RE 4	XIF 29	LC 6	LD 11	-	-	0.75	wh/rd
RE 5	-	-	-	-	-	0.75	wh
-	-	-	-	-	-	-	-
RH 3	-31	-	-	-	-	0.75	gr/or
RH 4	RB 8	-	-	-	-	0.75	gr/ye
RH 5	F04a	RB 7	VDC 3	DD 1	-	0.75	gr/gn
-	-	-	-	-	-	-	-
RL 1	-31	-	-	-	-	1.5	br
RL 4	RB 6	-	-	-	-	0.75	gn/vi

**08b PTO shaft circuit II Auxiliary power take-off / Power hydraulics****from serial no. 51**

**Key to diagram**

Item	Component	Co-ordinates
A62	EXT module	6-k-19
-	-	-
K01	Relay 15a	6-k-19
K02	Relay 15b	6-k-19
K07	Power relay power supply	6-k-19
K42	Taillight relay	6-k-19

**Description of function**

External operation of semi-mounted or vehicle-mounted implements

The circuit diagram shows the possible connections for an external control unit for semi-mounted or vehicle-mounted implements. The use of this external control unit is unit-specific and has usually been co-ordinated with the CLAAS development dept. Further circuit diagrams are included in the documentation of the semi-mounted or vehicle-mounted implement. In case of malfunctions, see diagnosis table 9 and the "Pin assignment in modules" chapter.

**Diagnosis table 9**

Module A62 EXT		
Status/operating status	CDS display target value	CDS display actual value
White control valve, neutral	Neutral	x
White control valve, lift	Lift	x
White control valve, lower	Lower	x
Red control valve, neutral	Neutral	x
Red control valve, lift	Lift	x
Red control valve, lower	Lower	x
Yellow control valve, neutral	Neutral	x
Yellow control valve, lift	Lift	x
Yellow control valve, lower	Lower	x
Green control valve, neutral	Neutral	x
Green control valve, lift	Lift	x
Green control valve, lower	Lower	x
Area counter started	On	x
Area counter stopped	Off	x

**11a ISO signal socket**







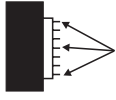
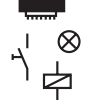
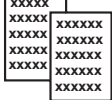

Module A56 VDC						
Module pin	CCN	Description	Measuring variable set value	Measuring variable actual value	Direction	Circuit diagram
X1/1	A52 - S5	F4 button	T signal 6 Volt <sub>eff</sub>	CDS		11
X1/8	A52 - S3	F2 button	T signal 6 Volt <sub>eff</sub>	CDS		11
X1/10	A52 - S6	F3 button	T signal 6 Volt <sub>eff</sub>	CDS		11
X1/13	A52 - S4	F1 button	T signal 6 Volt <sub>eff</sub>	CDS		11
X1/18	-	T signal 1	T signal 6 Volt <sub>eff</sub>	CDS		11
X3/10	F04	Ignition plus	12 Volt	CDS		8, 10, 11, 32, 41, 44, 49

**Key to diagram**

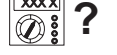
Item	Component	Co-ordinates
A55	Electrohydraulic steering module (EHL)	5-l-19
A60	HYD module	6-k-19
A61	XIF module	6-k-19
-	-	-
DA	Board	6-k-19
DS	VIA Diagnosis connector (63-pin)	6-k-19
-	-	-
K01	Relay 15a	6-k-19
K02	Relay 15b	6-k-19
K06	External power relay	6-k-19
K07	Power relay power supply	6-k-19
K14	Transport mode relay	6-k-19
K19	External wheel angle position indicator 1 relay	6-k-19
K20	External wheel angle position indicator 2 relay	6-k-19
K42	Taillight relay	6-k-19
-	-	-
XC	Vehicle-mounted implement connector	6-j-19
XCB	Vehicle-mounted implement connector - Row B	6-j-19
XCC	Vehicle-mounted implement connector - Row C	6-j-19
XCD	Vehicle-mounted implement connector - Row D	6-j-19
XCE	Vehicle-mounted implement connector - Row E	6-j-19
XCF	Vehicle-mounted implement connector - Row F	6-j-19
XK	Autopilot front socket	6-c-19

**Description of function**

-- None

Module A60 HYD						
Module pin	CCN		Measuring variable set value	Measuring variable actual value	Direction	Circuit diagram
						
31	B139-1	Front hydraulics position	0.25 - 4.75Volt	CDS		20
35	A52A52-S10A52-S11A52-S12A52-S13	unactuatedliftlowerfloat position-neutral	2.5 Volt 2 Volt 3 Volt 3.75 Volt 1.25 Volt	CDS		20
38	-	Not used	-	CDS		20









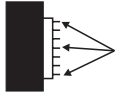

CLICK HERE TO **DOWNLOAD** THE COMPLETE MANUAL

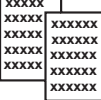



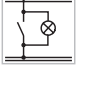



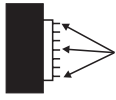

- Thank you very much for reading the preview of the manual.
- You can download the complete manual from: [www.heydownloads.com](http://www.heydownloads.com) by clicking the link below

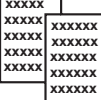

- Please note: If there is no response to CLICKING the link, please download this PDF first and then click on it.

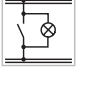
CLICK HERE TO **DOWNLOAD** THE COMPLETE MANUAL

Module A58 EHR						
Module pin	CCN	Description	Measuring variable set value	Measuring variable actual value	Direction	Circuit diagram
						
40	-	Plus power supply of sensors	approx. 10 Volt	CDS		21
43	B144-1	Tractive force, left	approx. 5 Volt, unloaded	CDS		21
54	Y198-2a	Reference PWM lifting	X Amperes	CDS		21

Module A60 HYD						
Module pin	CCN	Description	Measuring variable set value	Measuring variable actual value	Direction	Circuit diagram
						
1	F 05	Plus supply	12 Volt	CDS		20, 21, 23, 26
11	A52A52-S14A52-S15A52-S16A52-S17	unactuatedliftingloweringworking positiontransport position	2.5 Volt 2 Volt 3 Volt 3.75 Volt 1.25 Volt	CDS		21
21	R52	Power lift position set value	0 - 5Volt	CDS		21
26	-	Reference voltage	5 Volt	CDS		20, 21

Connector pin assignment

Socket LE, RE, RJ

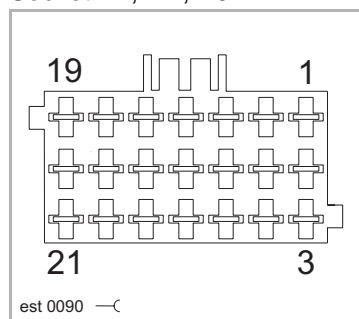

Connector LF

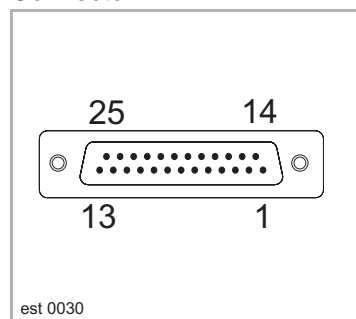

**23a Blue service valve**











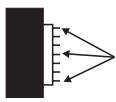

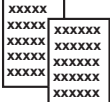

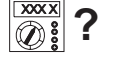
T signal

The T signal is a clocked signal. When measuring the signal with a multimeter, the result is U 1/2. With a 12 Volt system, this equals approx. 6 Volt<sub>eff</sub>. T signal circuits are frequently used for safety-relevant functions. When the T signal is disturbed by a short-circuit against plus or minus, the electronic unit performs no switching operations. The electronic unit accepts only properly clocked signals at the defined frequency as switching input.

DTC

The DTC is a CLAAS-internal fault code. It is displayed in the red alarm window along with the CEBIS fault message as a code made up of letters and numbers.

**Diagnosis table 26**

Module A60 HYD						
Module pin	CCN	Description	Measuring variable set value	Measuring variable actual value	Direction	Circuit diagram
						
1	F 05	Plus supply	12 Volt	CDS		20, 21, 22, 23, 26
5	Z102-1	Working hydraulics filter bypass	T signal 6 Volt <sub>eff</sub>	CDS		26
7	Z19	Hydraulic oil level Switch point 0 Switch point 1 Switch point 2 Switch point 3 Switch point 4 Switch point 5 Switch point 6	0 - 5 Volt 4.0 Volt 3.5 Volt 3.0 Volt 2.5 Volt 2.0 Volt 1.5 Volt 1.0 Volt			26
10	Z102-2	Steering hydraulic filter bypass	T signal 6 Volt <sub>eff</sub>	CDS		26
29	-	T signal HYD module	T signal 6 Volt <sub>eff</sub>	CDS		4, 20, 26
34	B123	Hydraulic oil temperature	0 - 5 Volt	CDS		26
37	Z102-3	Oil tank return line filter bypass	T signal 6 Volt <sub>eff</sub>	CDS		26

## Description of function

System concept of electrohydraulic steering (EHL)

The XERION is equipped with the EHL steering system SLC 018 301. To improve vehicle manoeuvrability, both axles may be steered. The electrohydraulic steering system not only stabilises the steering behaviour of the vehicle, but also enables extensive control during fieldwork.

Operating modes

At present, a distinction is made between the operating modes emergency steering, Orbitrol steering with rigid axle or floating axle and fully electrohydraulic steering (steer-by-wire). In the Orbitrol steering mode with rigid axle or floating axle, the front axle is steered fully hydraulically. The rear axle is steered electrohydraulically, but cannot be influenced. At high vehicle speeds (road travel), the rear axle is tracked in straight ahead position. Fully electrohydraulic steering operation (steer-by-wire) is active along with the special steering programs and the Autopilot. Due to the safety concept of the electrohydraulic steering (EHL), this steering mode is available only for fieldwork.

Representation of operating modes in the Technical Systems / Hydraulic Systems documentation

The possible operating modes of the electrohydraulic steering (EHL) are shown in the Technical Systems / Hydraulic System documentation, using explanatory symbol circuit diagrams. In order to understand the system engineering dependencies, it is necessary to use this documentation as well.

Operating mode Orbitrol steering with floating axle or rigid axle (Front axle steering)

In these operating modes, the front axle as relative to the cab position is always steered hydraulically via the Orbitrol (609). The steering sense remains the same and is activated mechanically and hydraulically as a function of cab position.

Identification of cab position

To be able to actuate those solenoid coils in the steering valve block which reflect the operating mode, the electrohydraulic steering module (A55) must know the cab position. The cab position is read in via the cab position switches (Z113, Z114). For safety reasons, this circuit is redundant. Both switches are read in. See also the logics table: Cab position identification.

Operating mode Orbitrol steering with floating axle or rigid axle (Rear axle steering)

In the Orbitrol steering operating mode, it is always the rear axle as relative to the cab position which is steered electrohydraulically via the respective automatic steering solenoid coils (Y190). Rear axle steering is program-controlled via the electrohydraulic steering module (A55). The following parameters influence the rear axle being steered as well:

- The ground speed which is read in redundantly via the transmission speed sensor (B16-2) and the transmission control CAN bus (B16-1).
- Front axle steering angle, read in redundantly from the respective sensor (B151 or B152)

Operating mode Orbitrol steering with floating axle or rigid axle (Rear axle hydraulic locking)

Hydraulic locking of the rear axle by the corresponding steering shut-off valve solenoid coils (Y188) is above a programmed speed via the electrohydraulic steering module (A55). When a steering movement of the rear axle is identified by the respective sensor (B151 or B152) in the locked state, e.g. due to hydraulic overload, the operator is alerted by an alarm. When decelerating the vehicle, the rear axle is unlocked again and aligned with the front axle under program control. The alarm can be acknowledged with the OK key on the CEBIS terminal. For fault diagnosis, please refer also to the Technical Systems / Hydraulic System documentation.

Operating mode Fully electrohydraulic steering (steer-by-wire)

Access to this steering mode depends on the road travel switch (red) (S52). See circuit diagram 4. In this operating mode, the drive management limits the maximum ground speed to 20 km/h. In this operating mode, the Orbitrol steering unit is short-circuited hydraulically via the corresponding steering definition valve solenoid coils (Y189) and has no limits. The steering commands come from the redundant steering wheel sensors (B150-1, B150-

**28b EHL (Autopilot), Cab position identification**  
from serial no. 51

**Connector pin assignment**

Socket DG, JW, RF, RG, RH

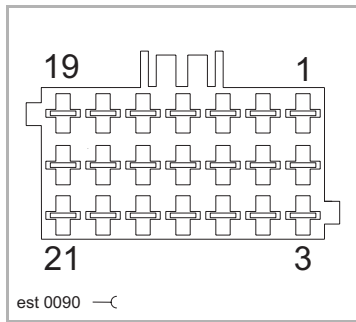

Connector LF

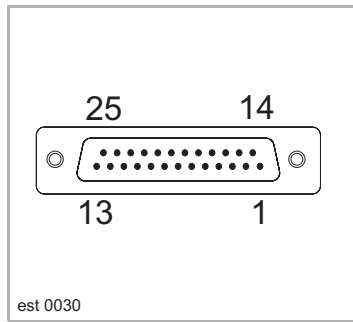

Socket LH, LK

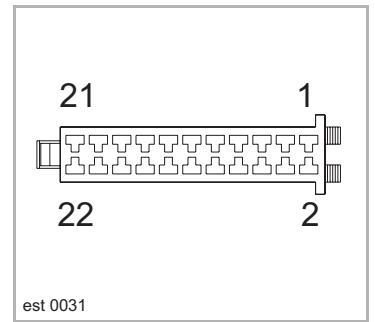

Socket LP, LQ

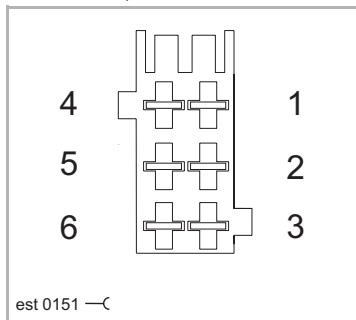

**Interconnection list**

from	to 1	to 2	to 3	to 4	to 5	mm <sup>2</sup>	Colour
DG 11	JW 3	RG 11	-	-	-	0.75	rd/bk
-	-	-	-	-	-	-	-
JW 3	RG 11	DG 11	-	-	-	0.75	-
-	-	-	-	-	-	-	-
LF 12	RF 11	-	-	-	-	0.75	-
LF 13	F13a	RG 5	LP 3	LQ 3	LH 6	0.75	-
-	LD 20	DA 43	DA 44	-	-	-	-
-	-	-	-	-	-	-	-
LH 4	RF 20	-	-	-	-	0.75	gn/gr
LH 5	RF 19	-	-	-	-	0.75	gn/bl
LH 6	F13a	RG 5	LF 13	LP 3	LQ 3	0.75	gn/rd
-	LD 20	DA 43	DA 44	-	-	-	-
LH 7	-31	-	-	-	-	0.75	br
LH 8	RF 21	-	-	-	-	0.75	gn/vi
LH 9	RF 18	-	-	-	-	0.75	gn/bk
-	-	-	-	-	-	-	-
LK 15	RF 5	DS 19	-	-	-	0.75	gn/rd
LK 16	K9/86	RF 15	DS 18	-	-	0.75	gn/ye

**Key to diagram**

Item	Component	Coordinates
A60	HYD module	6-k-19
-	-	-
K01	Relay 15a	6-k-19
K02	Relay 15b	6-k-19
K07	Power relay power supply	6-k-19
K13	Floating axle lock relay	6-k-19
K46	Alternator relay	6-k-19
-	-	-
S120	Floating axle lock switch	5-k-19
-	-	-
Y192	Floating axle lock solenoid coil	8-j-18
Y193	Floating axle unlock solenoid coil	8-j-18
-	-	-
Z105-1	Floating axle lock 55 bar pressure switch	8-j-18
Z105-2	Floating axle lock 115 bar pressure switch	8-j-18

**Measuring value table**

Item	Component	Measuring value	Remark
Y192Y1 93	Solenoid coil	approx. 8Ω	at 20°C
Z105-1	Floating axle locking pressure switch	Switch point 55 bar	Normally closed contact
Z105-2	Floating axle locking pressure switch	Switch point 115 bar	Normally closed contact

**Description of function**

Unlocking the floating axle

When deactivating the floating axle lock using the Lock floating axle switch (S120), the Unlock floating axle solenoid coil (Y193) is permanently energised. The floating axle lock hydraulic cylinders retract due to the ram pressure of the oil cooling and the filtering.

Locking the floating axle, stage 1 at 55 bar

The Lock floating axle switch (S120) activates the floating axle lock, stage 1. The closed floating axle locking pressure switch (Z105-1) activates the relay (K13) until the switch opens at approx. 55 bar. In parallel with the Lock floating axle solenoid coil (Y192), relay K13 also activates the constant-pressure circuit in order to build up the necessary working hydraulics system pressure required for this function. See also circuit diagram 4.

**32b Locking the differentials**

from serial no. 51

Cab locked sensor (B147)

The mechanical cab lock components are monitored by the cab locked sensor (B147). This sensor switches when it detects metal. The sensor is provided with a LED for diagnosis purposes. Important: When the cab is unlocked, this LED only lights up weakly. The highlighted area around the sensor surface must be free of metals.

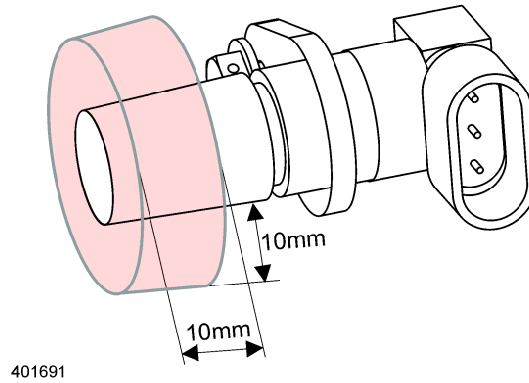

Diagnosis table 33

Module A61 XIF						
Module pin	CCN	Description	Measuring variable set value	Measuring variable actual value	Direction	Circuit diagram
1	F07	Power supply plus	12 Volt	CDS		2. 7. 8. 32. 33. 43
11	S118	Cab unlocked	T signal 6 Volt <sub>eff</sub>	CDS		33
29	-	T signal XIF module	T signal 6 Volt <sub>eff</sub>	CDS		2. 7. 8. 32. 33
36	B147	Cab lock sensor	0.4 Volt = 04.6 Volt = 1	CDS		33

**Key to diagram**

Item	Component	Co-ordinates
K01	Relay 15a	6-k-19
K02	Relay 15b	6-k-19
K07	Power relay power supply	6-k-19
-	-	-
M13	Front windscreen washer motor	5-m-20
M16	Front windscreen wiper motor	5-i-20
-	-	-
S42	Windscreen washer switch	5-j-19
S43	Windscreen wiper switch	5-j-19
-	-	-
V17	Windscreen wiper controller (K55)	5-k-19

**Description of function**

None

**Connector pin assignment**

Socket LI, LK

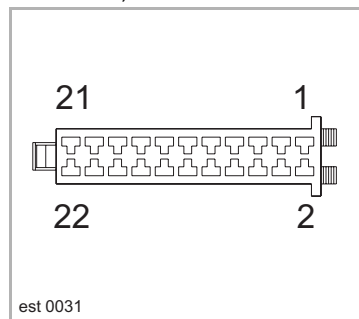

**Interconnection list**

from	to 1	to 2	to 3	to 4	to 5	mm <sup>2</sup>	Colour
LI 9	F52a	LB 18	K55/8	-	-	1.5	bk
LI 10	LK 12	-	-	-	-	1.5	vi
LI 11	K55/1	-	-	-	-	1.5	bk/br
LI 12	K55/7	-	-	-	-	1.5	bk/rd
LI 13	K55/9	-	-	-	-	1.5	bk/vi
LI 14	K55/2	-	-	-	-	1.5	gr/ye
LI 15	K55/3	-	-	-	-	1.5	bk/gr
LI 16	K55/6	-	-	-	-	1.5	gr/rd
LI 17	K55/5	-	-	-	-	1.5	gr/gn

**Connector pin assignment**

Socket LN, RC, RE, RJ

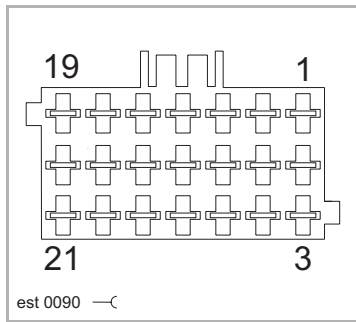

**Interconnection list**

from	to 1	to 2	to 3	to 4	to 5	mm <sup>2</sup>	Colour
LN 1	K15/86	DS 6	-	-	-	0.75	gn/rd
LN 2	F54a	LN 3	-	-	-	2.5	bk
LN 3	F54a	LN 2	-	-	-	2.5	bk
-	-	-	-	-	-	-	-
RC 1	K15/85	LA 10	DS 5	-	-	0.75	vi
-	-	-	-	-	-	-	-
RE 20	-31	-	-	-	-	2.5	br
RE 21	-31	-	-	-	-	2.5	br
-	-	-	-	-	-	-	-
RJ 14	K15/87	DS 4	-	-	-	1.5	bk/vi
RJ 15	-31	-	-	-	-	1.5	br

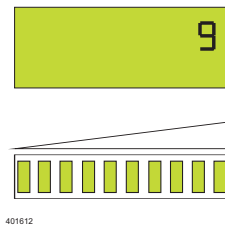
Fan speed (100%) Cab fan  
(M7)

Example: Test step 9 is displayed

The speed is displayed as a bar display. If the cab fan does not start, check the following:

- 1 Connector on cab fan (below the roof cover).
- 2 Cab fan speed controller module (A7) below the roof cover. Slacken off the cover screws and remove cover.
- 3 Voltage on cab fan motor. Target value: 11.5 - 14.5 V. The cab fan speed controller module (A7) must be connected.
- 4 Check the cab fan motor mechanically. Abraded particles of carbon brushes.
- 5 Connector on the cab fan speed controller (A7).
- 6 Fuse (F33, 1.5A)
- 7 If cable to the cab fan motor (M7) has a short-circuit or is broken.

10<sup>th</sup> menu item

Press key (3) once.

All outputs of the automatic air conditioner module (A6) are activated.

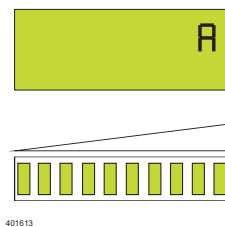
Automatic air conditioner  
module (A6) outputs

Example: Test step 10 is displayed

The speed is displayed as a bar display. If the cab fan does not start, check the following:

- 1 The heater solenoid coil (Y109) is energised.
- 2 The compressor-type air conditioner electro-magnetic clutch solenoid coil (Y32) is activated.
- 3 The cab fan motor (M7) is switched on and works at max. speed.
- 4 Check the cab fan motor mechanically. Abraded particles of carbon brushes.
- 5 Connector on the cab fan speed controller (A7).
- 6 Fuse (F33, 1.5A)
- 7 If cable to the cab fan motor (M7) has a short-circuit or is broken.

11<sup>th</sup> menu item

Press key (3) once.

All segments of the bar and the seven-segment displays are switched on.

## Segment display

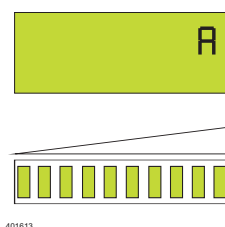

All segments of the seven-segment displays are switched on.

All segments of the bar display are switched on. The display function can be checked by visual inspection.

12<sup>th</sup> menu item

Press key (3) once. The automatic air conditioner module (A6) carries out a RESET. Now the software version is displayed. The automatic air conditioner module (A6) is in normal operation again.

**Key to diagram**

Item	Component	Co-ordinates
K01	Relay 15a	6-k-19
K02	Relay 15b	6-k-19
K07	Power relay power supply	6-k-19
-	-	-
XS-1	12V Service connector	5-l-19
XS-2	12V Service connector	5-l-19
XS-3	12V Service connector	5-l-19
XV-1	Front power supply connector	9-d-19
XV-2	Rear power supply connector	7-q-19
XV-3	Cab power supply connector	5-j-19

**Description of function**

None





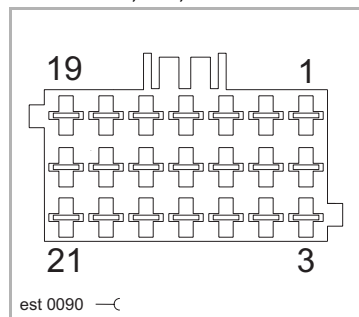





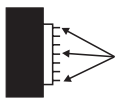

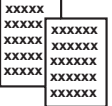

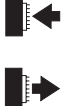
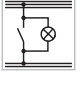
**Connector pin assignment**







Socket DF, LB, RD

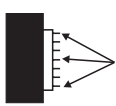

**Interconnection list**

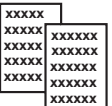
from	to 1	to 2	to 3	to 4	to 5	mm <sup>2</sup>	Colour
DF 1	F33a	DF 2	-	-	-	2.5	rd
DF 2	F33a	DF 1	-	-	-	2.5	rd
-	-	-	-	-	-	-	-
LB 2	-31	-	-	-	-	2.5	br
LB 3	-31	-	-	-	-	2.5	br
LB 4	-	-	-	-	-	2.5	rd
LB 5	-	-	-	-	-	2.5	rd
-	-	-	-	-	-	-	-
RD 1	F34a	RD 2	RD 3	-	-	2.5	rd
RD 2	F34a	RD 1	RD 3	-	-	2.5	rd

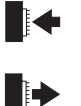
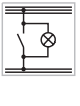
Module A56 VDC						
Module pin	CCN	Description	Measuring variable set value	Measuring variable actual value	Direction	Circuit diagram
						
X2/11	S109	Ground speed control lever forward -no	T signal 6 Volt <sub>eff</sub>	CDS		41
X2/13	Z81	Brake pressure	T signal 6 Volt <sub>eff</sub>	CDS		41
X2/14	B148	Brake pedal	Low - high	CDS		41
X2/16	S93	Parking brake switch	0/12 Volt	CDS		41
X2/17	Z5	Seat contact	0/12 Volt	CDS		41
X3/05	K17	Parking brake release	12 Volt	CDS		41
X3/10	F04	Ignition plus	12 Volt	CDS		8, 10, 32, 41, 44, 49
X4/04	B149	Sensor ground	0 Volt	CDS		41
X4/12	B149	Inch signal	4.75 - 0.25Volt	CDS		41

Module A57 TCU						
Module pin	CCN	Description	Measuring variable set value	Measuring variable actual value	Direction	Circuit diagram
						
41	Z115	Inching pedal contact	12 Volt	CDS/TCU		41
45	F20	Ignition plus	12 Volt	CDS/TCU		7, 41, 42, 44

## Description of function

Selecting the direction of travel when driving off	When driving off, keep switch (start/reversing pushbutton) (A52-S8) pressed and move the ground speed control lever to the desired direction of travel. During this process, the signals from the ground speed control lever switches (S109 or S110) change. The switch (start/reversing pushbutton) (A52-S8) serves as a safety feature in order to avoid an unintended change of the direction of travel. The selection of the direction of travel always remains consistent with the cab position. In order to enable this, the EHL module (A55) reads in the current cab position and transmits it to the module A56 (VDC) via the CAN bus. See also circuit diagram 28.
Deleting the selection of the direction of travel when the seat contact switch is not actuated	When selecting a direction of travel with the seat contact switch not actuated, the vehicle must drive off within 30 seconds. After the 30-second period has elapsed, the selection of the direction of travel is deleted. The direction of travel must now be newly selected.
Automotive driving mode	After each re-start, the machine is in the automotive driving mode. In this mode, the vehicle is in the non-positive standstill (powered zero) following the selection of the direction of travel and with the ground drive pedal unactuated. In the transmission, a directional clutch (forward or reverse) is engaged and an output speed of 0 is set by the hydraulic-mechanic torque split. The vehicle can drive off using the ground drive pedal as soon as the start/reversing pushbutton (A52-S8) is released.
Actuating the ground speed control lever towards decelerating	The position of the ground speed control lever normally is not important when driving off in automotive driving mode unless the ground speed control lever has been moved towards „Deceleration“. In this case, driving is at increased engine speed as long as the ground speed control lever is kept in that position (transmission ratio reduction).
Transmission ratio reduction	When driving in automotive driving mode and moving the ground speed control lever towards decelerating, <ul style="list-style-type: none"> <li>– the transmission ratio is reduced,</li> <li>– the max. engine speed of 2450 rpm is not exceeded permanently in this process. However, exceeding this value for a short time is allowed.</li> </ul> <p>By releasing the ground speed control lever and actuating the ground drive pedal towards acceleration, the reduced transmission ratio is cancelled again.</p>
Change of direction of travel, reversing	When actuating the start/reversing pushbutton (A52-S8) while driving, the CEBIS terminal (A30) displays the new direction of travel by flashing. As soon as the new direction of travel is active, the new direction of travel is displayed permanently on the CEBIS terminal (A30). This does not depend on whether the ground drive pedal is pressed or not. In the deceleration phase, reversing can be supported with the service brake at any time.
Selecting the drive range	The drive range switch (S111) allows varying the ground drive pedal range. In the fast drive range, the top speed always equals the maximum vehicle speed. The use of the special steering programs (steer-by-wire) is an exception to this since these programs are limited to a top speed of 20 km/h. In the slow drive range, the top speed can be freely programmed on the CEBIS terminal (A30). A separate cruise control value can be selected for both drive ranges.
Cruise control function	The cruise control ON/OFF switch (A52-S7) allows setting a cruise control value in the following 4 ranges. <ul style="list-style-type: none"> <li>– Fast forward drive range.</li> <li>– Fast reverse drive range.</li> <li>– Slow forward drive range.</li> </ul>

**42a Limp Home**

**up to serial no. 50**

**Key to diagram**

Item	Component	Co-ordinates
A61	XIF module	6-k-19
-	-	-
B146	Compressed air sensor	9-o-19
-	-	-
K01	Relay 15a	6-k-19
K02	Relay 15b	6-k-19
K07	Power relay power supply	6-k-19
K10	Switch-over relay	6-k-19
K23	Relay 54	6-k-19
K41	Switch-over relay 54	6-k-19
-	-	-
XA	7-pin tail socket	7-q-19
XH	7-pin front socket	9-d-20
-	-	-
Y106-2	Parking brake solenoid coil (pneumatic)	8-o-18
Y239	Trailer brake system advance solenoid coil	8-o-18
-	-	-
Z12	Parking brake actual value switch	6-j-19

**Connector pin assignment**

Socket RB, RH

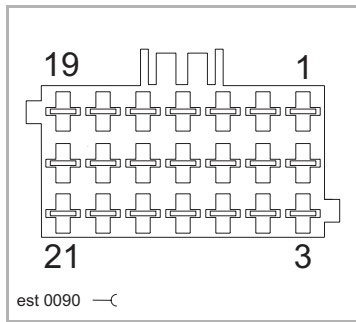

**Interconnection list**

from	to 1	to 2	to 3	to 4	to 5	mm <sup>2</sup>	Colour
RB 7	F04a	VDC 3	RH 5	-	-	0.75	bl/vi
RB 9	-31	-	-	-	-	0.75	vi
-	-	-	-	-	-	-	-
RH 10	F20a	LI 19	LJ 5	LT 3	TCU 1	0.75	or
RH 11	TCU 4	-	-	-	-	0.75	or/ye
RH 12	TCU 2	-	-	-	-	0.75	or/gn

**45a Lighting main circuit, taillight, position light**

**47a Worklights I**

**up to serial no. 50**

**Key to diagram**

<b>Item</b>	<b>Component</b>	<b>Co-ordinates</b>
DB	Diode board	6-k-19
-	-	-
E76	Cab rear wall left inside work light	2-m-20
E77	Cab rear wall left centre work light	2-m-20
E78	Cab rear wall left outside work light	2-m-21
E79	Cab rear wall right inside work light	2-m-19
E80	Cab rear wall right centre work light	2-m-19
E81	Cab rear wall right outside work light	2-m-18
-	-	-
K01	Relay 15a	6-k-19
K02	Relay 15b	6-k-19
K07	Power relay power supply	6-k-19
K30	Rear wall outside worklight relay	6-k-19
K31	Rear wall centre worklight relay	6-k-19
K32	Rear wall inside worklight relay	6-k-19
K42	Relay 58	6-k-19
K47	Alternator protection relay	6-k-19
-	-	-
S3-1	Rear wall worklight switch	2-j-19

**Key to diagram**

Item	Component	Co-ordinates
A56	VDC module	6-l-19
-	-	-
E22	Left brake light	6-r-22
E23	Right brake light	6-r-17
E62-1	Left back-up light	6-r-22
E62-2	Right back-up light	6-r-17
-	-	-
H41	Horn	6-j-19
-	-	-
K01	Relay 15a	6-k-19
K02	Relay 15b	6-k-19
K07	Power relay power supply	6-k-19
K09	Switch-over relay	6-k-19
K18	Back-up light relay	6-k-19
K41	Switch-over relay 54	6-k-19
K48	Back-up signal relay	6-k-19
-	-	-
S48	Horn switch	5-j-19

<b>CCN</b>	<b>Component</b>	<b>Circuit diagram</b>
S107	Steering position left offset switch	28
S108	Steering position right offset switch	28
S109	Ground speed control lever forward switch	41
S110	Ground speed control lever reverse switch	41
S111	Drive range switch	41
S112	Limp Home switch	42
S113	Switch Front PTO On/Off (auxiliary power take-off)	8
S114	Switch Tail PTO On/Off	7
S115	Switch Engine speed set / reset electronic throttle	2
S118	Switch Unlock cab	33
S119	Switch Differential lock automatic / manual	32
U22	Diesel engine diagnosis switch	2
U28	External switch Raise tail power lift	21
U29	External switch Lower tail power lift	21
U30	External switch Tail PTO On/Off	7
U30-2	External switch Tail PTO On/Off	7
U32	External switch Raise front power lift	20
U33	External switch Lower front power lift	20
Y105-1	Solenoid coil Differential lock	32
Y105-2	Solenoid coil Differential lock (cross)	32
Y188-1	Solenoid coil Steering shut-off valve	28

CLICK HERE TO **DOWNLOAD** THE COMPLETE MANUAL

- Thank you very much for reading the preview of the manual.
- You can download the complete manual from: [www.heydownloads.com](http://www.heydownloads.com) by clicking the link below



- Please note: If there is no response to CLICKING the link, please download this PDF first and then click on it.

CLICK HERE TO **DOWNLOAD** THE COMPLETE MANUAL