



Cat® Lift Trucks

Service Manual - Chassis & Mast

EP10CA1(J)-25(H)CA1(J),EP28CA1(J)-EP30CA1(J)



99759-6R110

Service Manual

Chassis & Mast

EP10/14/15/18(H)CA1(J)
EP20/25(H)CA1(J),EP28CA1(J)
EP30CA1(J)

221E20001-up 256E00792-up
241C10001-up 257C01120-up
251AC2001-up

Mitsubishi Caterpillar Forklift Europe B.V.
Hefbrugweg 77 1332 AM
Almere, The Netherlands

CLICK HERE TO **DOWNLOAD** THE COMPLETE MANUAL

- Thank you very much for reading the preview of the manual.
- You can download the complete manual from: www.heydownloads.com by clicking the link below



- Please note: If there is no response to CLICKING the link, please download this PDF first and then click on it.

CLICK HERE TO **DOWNLOAD** THE COMPLETE MANUAL

Work clothing

CAUTION

- When doing work, the worker must wear close-fitting work clothes, a safety hat, and safety shoes.
- ➔ Loose clothing can become caught in machinery and cause serious injury.

Tools and gauges

CAUTION

- Always use tools suitable for the work being performed. Use proper size tools when tightening and loosening parts of the forklift truck.
- ➔ Failing to use suitable tools can result in serious bodily injury or damage to the machine.

CAUTION

Before starting work, prepare the tools and gauges you will need.

Working safely

WARNING

- When hoisting a forklift truck or heavy component, always use ropes or cable with sufficient load capacity.
- Do not use kinked ropes or cables.

WARNING

After lifting or jacking up a forklift truck, support it with safety blocks or rigid stands.

WARNING

Apply wheel chocks to tires to prevent the forklift truck from moving.

WARNING

When working under a forklift truck, do the work from a work pit and take proper safety precautions.

■ How to use liquid packing

● Scrape before applying seal

1. Use a scraper or similar tool to remove sealer adhered to the contact surface of the casing. Do not scratch the surface when scraping. If you make a scratch, repair the surface with an oil stone.
2. To remove oil and contamination, wipe the contact surface with a cloth soaked in gasoline.
 - * Do not use kerosene, light oil, or crude oil.
 - * Do not allow dust and rust inside.

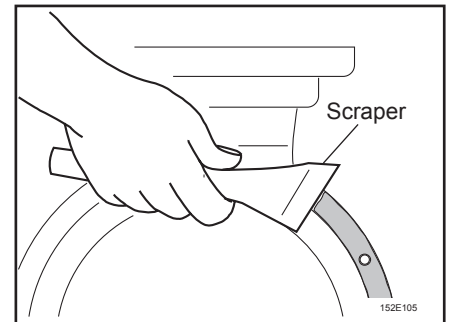

● Apply liquid packing

1. Cut the nozzle of the liquid packing tube at the second section so that bead width is 3 to 3.5 mm.

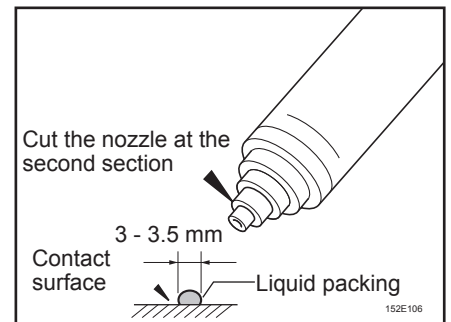

2. Attach a key to roll up the tube, and then apply liquid packing to the contact surface by rolling up the tube.
 - * To prevent oil leaks, smooth the packing so that it has even thickness.
 - * When applying liquid packing to bolt holes, apply it on the inner part of the contact surface.

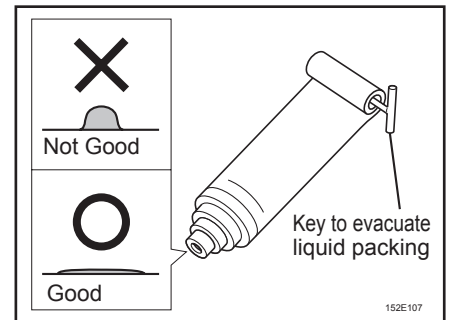

3. Attach to the contact surface within 15 minutes after applying the liquid packing.
4. When tightening bolts, first partially tighten them, and then further tighten them by moving from one to the next in a diagonal pattern.
5. Wait for at least 30 minutes before adding oil or operating the machine.
 - * To prevent oil leaks, always wait at least 30 minutes.

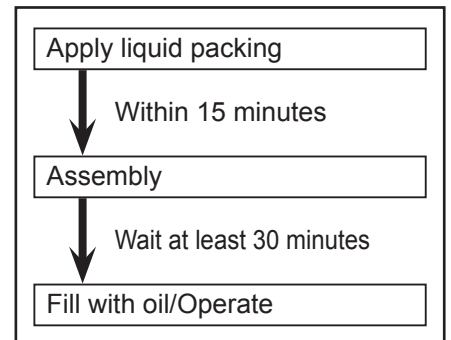

MEMO

A series of horizontal dashed lines for writing.

7. Remove Brake pipe with the following steps.

1. Drain the oil from Brake fluid tank.
2. Lower the crane and tilt the mast forward.
3. Disconnect Brake pipe on Wheel brake Ass'y side.

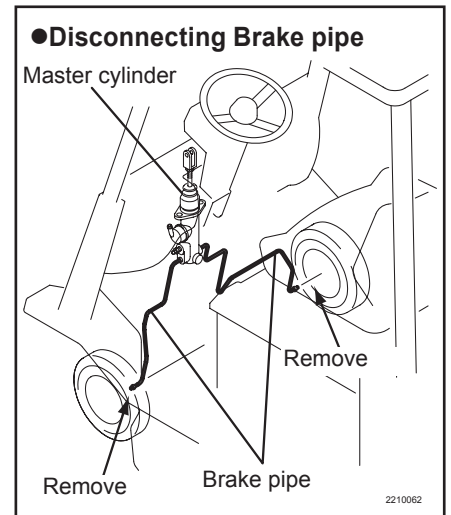

8. Replace Pivot cap with a specially processed cap with the following steps.

1. Lower the crane and tilt the mast forward.
2. Remove the upper mounting bolt of Pivot cap.
3. Raise the crane and return the mast to the vertical position.



Keep the wire rope pulled to the back of the truck.

4. Remove the lower mounting bolt of Pivot cap.

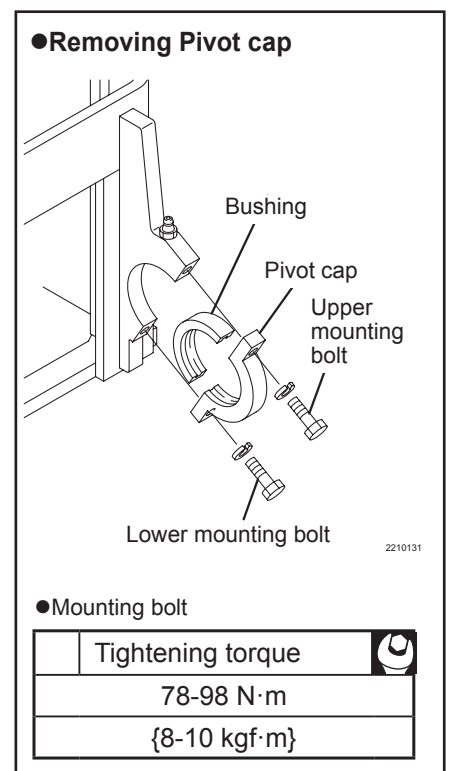

5. Replace Pivot cap with the special cap.
6. Hand tighten all bolts.
7. Lower the crane and tilt the mast forward.
8. With a tool, tighten the upper mounting bolt of the special cap.
9. Raise the crane and return the mast to the vertical position.



Keep the wire rope pulled to the back of the truck.

10. With a tool, tighten the lower mounting bolt of the special cap.

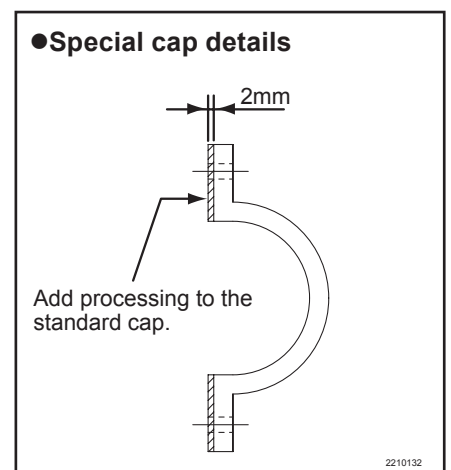

Wheel hub, drive shaft and etc.

● Disassembling and reassembling Front axle (4)

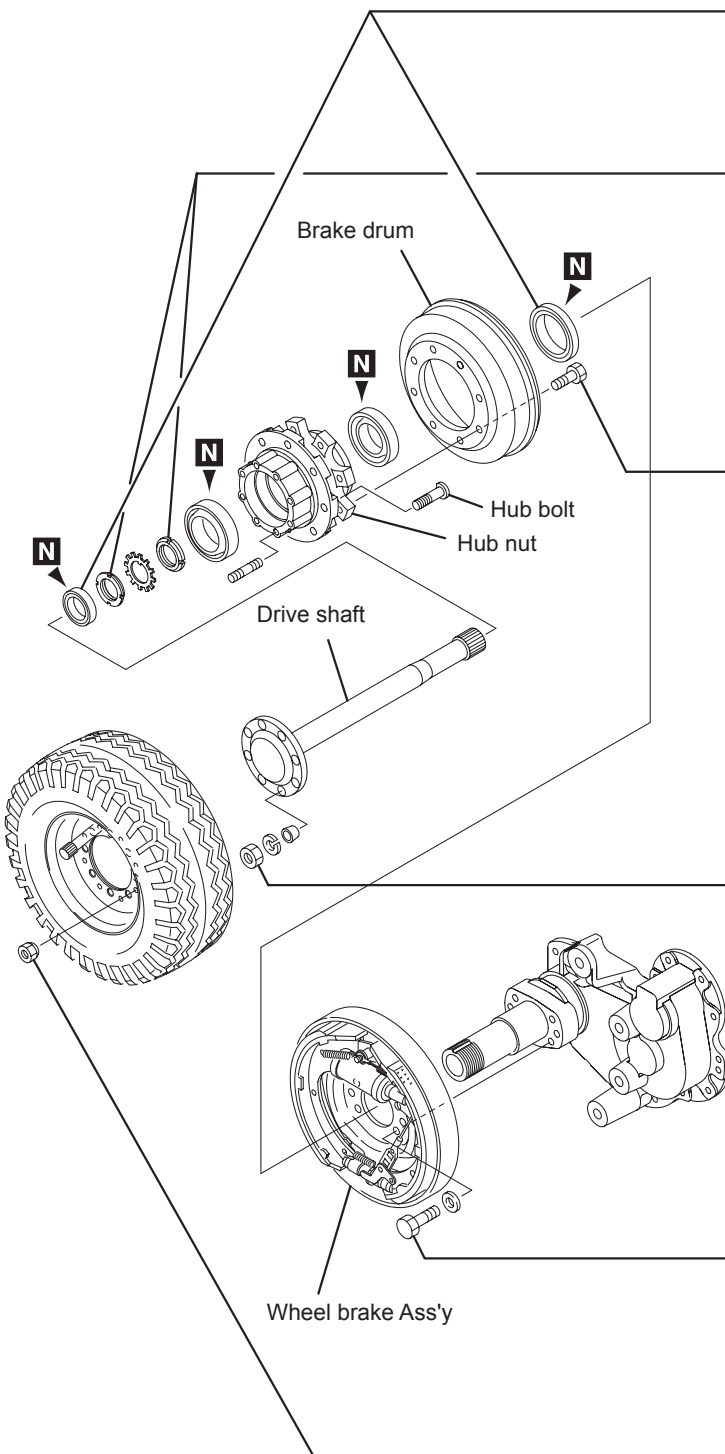

EP10CA1-14CA1	
Oil seal	B G
Outer circumference: Apply three bond [#1104] Lip part: Apply grease	

● Bearing nut

A	Bearing pre-load	
Measure at position A	392-686 N·m	
	{40-70 kgf·m}	

Tightening torque		B
Apply THREEBOND [#1360K] or equivalent, and tighten it.		
98-127 N·m		
{10-13 kgf·m}		

Tightening torque[EP10CA1-14CA1]		
78-108 N·m		
{8-11 kgf·m}		

Tightening torque		B
Apply THREEBOND [#1360K] or equivalent, and tighten it.		
176-235 N·m		
{18-24 kgf·m}		

● Hub nut

Tightening torque(M12)		
89 - 108 N·m		
{9 - 11 kgf·m}		

- C** : Tightening torque
- B** : Apply THREEBOND
- G** : Apply grease
- N** : Not reusable

221W007



If you remove any Oil seals, O-rings, or Bearings, replace them with new ones.

3-2-3. Rear axle - Reassembling method and caution

<EP10CA1/14CA1/15CA1/18CA1>

1. Adjust the length of Tie rod Comp. (L) and (R) so that the dimensions correspond to ※ marks.
 These marks are based on design dimensions, however, so lengths may vary depending on the actual parts. In this case, adjust length to correspond to the actual dimensions of the parts.
2. Insert a shim to adjust the ▲ dimension of stopper bolt (two places) in such a way that the angle shown by ★ dimension is formed

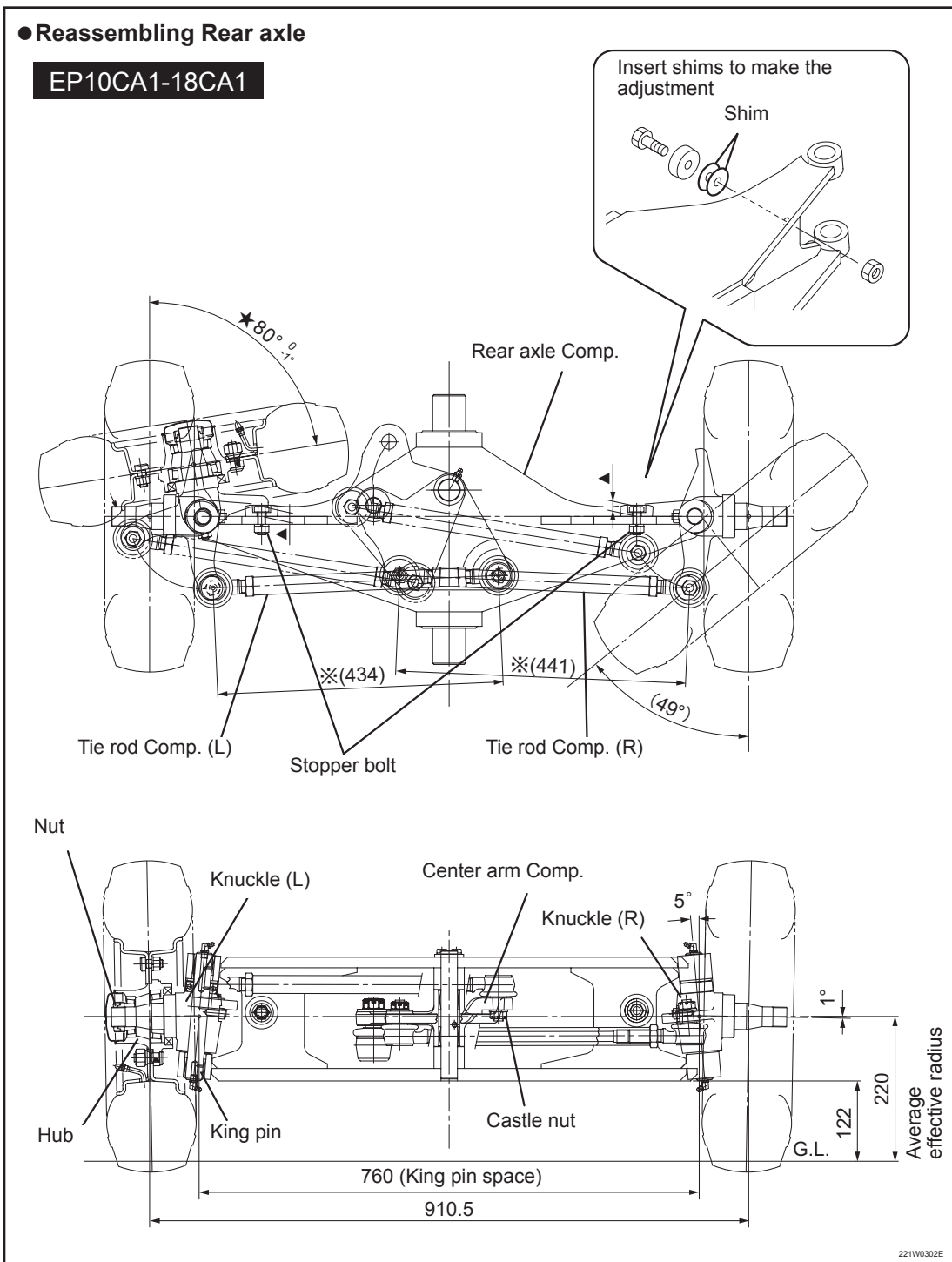

4-3. Troubleshooting

4-3-1. Tire - troubleshooting

No.	Symptom	Possible causes	Solution
1	Uneven wear of a wheel	1. Incorrect tire air pressure	Fill air to the specified pressure
		2. Incorrectly adjusted wheel alignment. (toe-in, camber, king pin, etc.)	Inspect and replace
		3. Incorrect wheel bearing preload	Adjust
		4. Difference between left and right wheels	Replace with same type of wheel

6-1-2. Parking brake linkage - names of parts

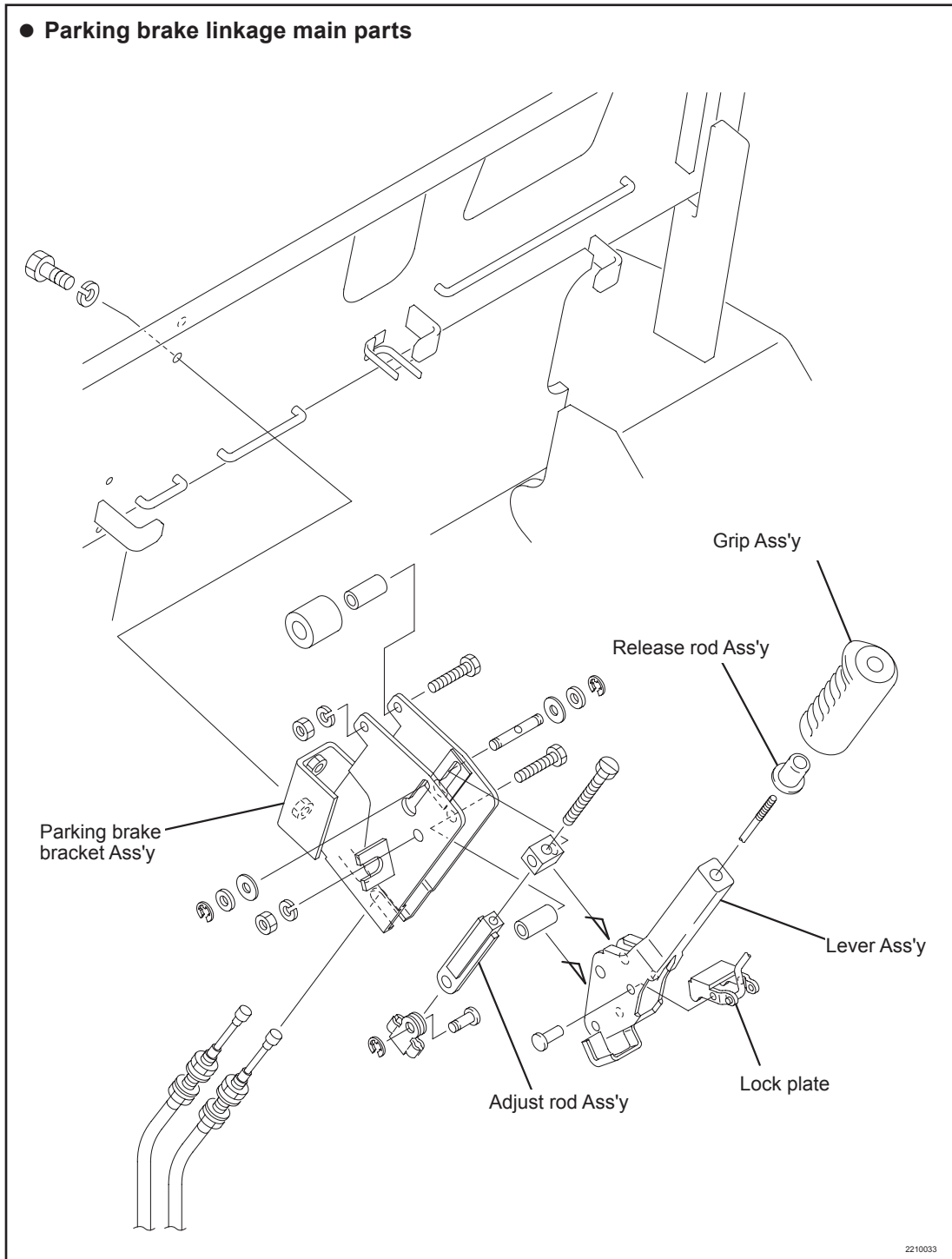

3. Use the microswitch mounting nut to adjust the ON/OFF position within the following standard dimension

Specified value	10-20mm
-----------------	---------

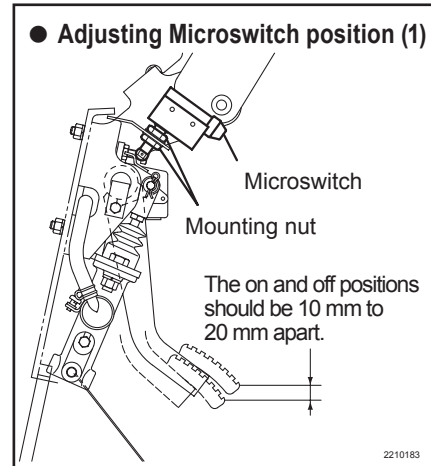

4. When Brake pedal is entirely pushed down, adjust Switch roller so that it is pushed down as per the following specific dimensions:

Specified value	2 mm or more Less than 4 mm
-----------------	--------------------------------

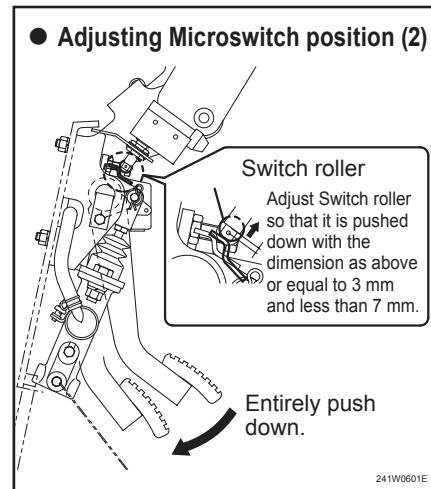

7b-2. Disassembly and reassembly

7b-2-1. Cautions when disassembling and reassembling Oil tank

- Pay attention to the following points when disassembling and assembling Oil tank:

CAUTION

- Apply wheel chocks to tires to prevent the truck from moving.
- When draining the hydraulic oil, remove Plug while the fork is lowered to the ground.
- Cap disconnected hydraulic piping to prevent dust and debris from getting into hydraulic components and pipes.
- When installing filter and plug, wrap and tighten the seal tape firmly on the screw threads.
- Always disconnect Battery plug.

7b-2-2. Cautions when replacing the oil piping

To replace hydraulic system or hose, refer to oil-hydraulic circuit design on page 87, and check the pipe connection.

NOTE

Wrap and tighten the seal tape on the piping screw.

CAUTION

- Only use hoses that meet pressure resistance requirements.

Pressure can cause unnecessary stress to hoses.



152E125

- Make sure that hoses are long enough.

Excessive bending and twisting can damage hoses.

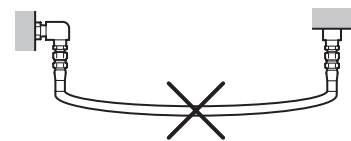
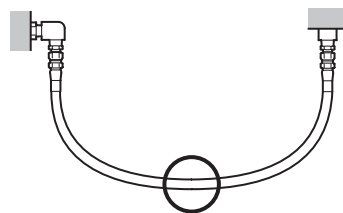

152E126

- Do not twist hoses when attaching them. Moreover, once a hose is attached, make sure that it does not get twisted during operation.

You can check for twisting by inspecting the string of letters marked on a hose.

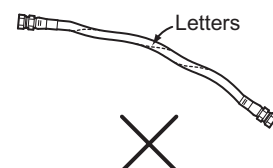
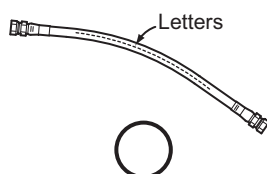

152E127

7c- 4. Troubleshooting

7c-4-1. Control valve - troubleshooting

No.	Symptom	Possible causes	Solution
1	Lift or tilt function does not work	1 Broken Pump or coupling	Replace
		2 Oil tank low on oil	Replenish
		3 Broken Plunger spring	Replace
		4 Broken Hydraulic microswitch	Replace
2	Cannot lift load within rated capacity	1 Broken or incorrectly adjusted Relief valve	Replace or adjust
		2 Broken Pump	Replace
3	Lifting speed is too slow.	1 Over-discharged battery	Charge battery
		2 Short plunger stroke	Inspect Valve linkage
		3 Damaged cylinder packing	Replace
		4 Relief pressure is too low	Adjust
		5 Damaged plunger packing	Replace
		6 Broken pump	Replace
		7 Clogged Oil filter	Clean/ Replace
		8 Improper adjustment of hydraulic chopper	Replace or adjust
4	Excessive lift and tilt drift	1 Damage of the packing of the plunger	Replace
		2 Damaged cylinder or piston	Replace
		3 Damaged piston packing	Replace
5	Lift starts too abruptly.	1 Incorrect activation timing of lift microswitches	Adjust
		2 Broken Relief valve	Replace
6	Oil leakage	1 Damaged O-ring or wiper ring	Replace
		2 Loose tie bolts of Hydraulic valve	Retighten

7d-2-4. Lift cylinder - installation and adjustment

1. Install Lift cylinder by performing the steps to remove it in reverse order.
2. Operate Lift lever to raise the mast. When the mast is fully raised, make sure that cylinder strokes are equal and that the mast does not lean to the right or left.
 - ▶ If you detect unequal stroke or lean, adjust cylinder with the following steps.
 - For 2SP-mast : Adjust by changing number of shims or thickness (t0.2/t0.5/t1.0).
 - For 3FP-mast : Adjust Head rod with Lock nut.
 - For 2FP-mast : Loosen Nut screw and adjust with Adjust bolt.

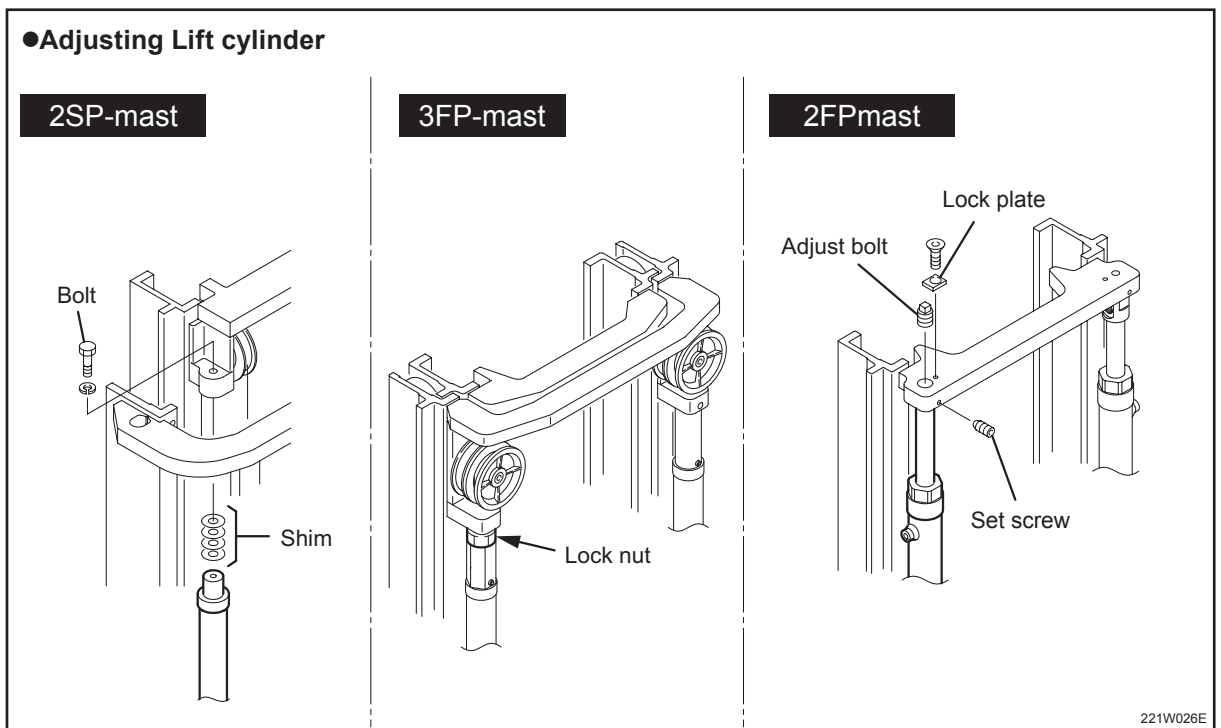

7d-2-5. Tilt cylinder - installation

1. Install Tilt cylinder in reverse order of removal.
2. Operate Tilt lever, and check for unequal right and left cylinder stroke for both start and end of stroke.
 - ▶ If unevenness is found, loosen the nut at the rod head and adjust by using the screw of the rod.

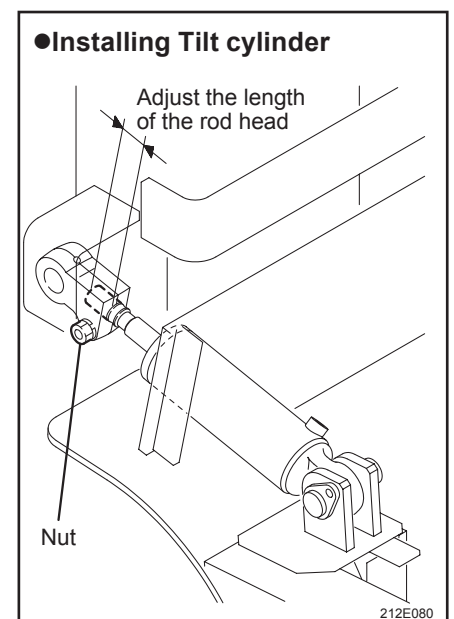

8. Disassembly of seals on Cylinder head.

Remove X-ring, Wiper ring, and O-ring.

1. Remove rings by using a spatula or a screwdriver.
2. Wiper ring is press-fitted. Remove Wiper ring by inserting a tool such as screw driver in the rubber from bushing side.
3. Remove O-ring and X-ring with the same manner by using a spatula or a screwdriver

**NOTE**

After seals are removed, do not reuse them.

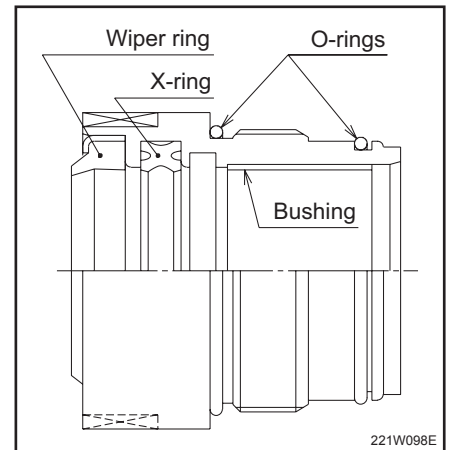

221W098E

9. Disassembly of Bushing in Cylinder head Use a jig, as shown in the illustration on the right, and pull Bushing out by using a press.

Or, pull out Bushing with the following procedure.

1. Groove the inner surface of Bushing by using a tool. (Groove parallel about 10 mm away from the joint.)
2. Insert a screwdriver into the joint of Bushing, and twist along the groove to bend the edge of Bushing.
3. Grab the bent part of Bushing with a plier and pull it out.

**NOTE**

Removed bush cannot be reused.

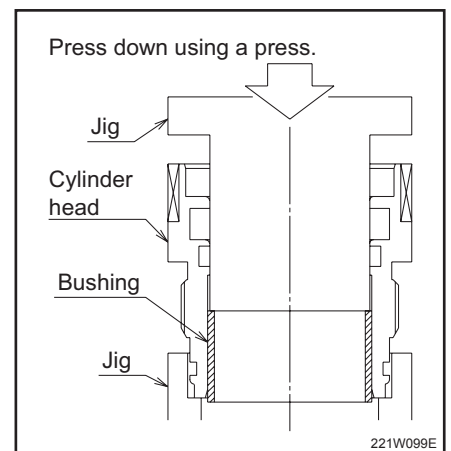

221W099E

10. Cleaning and storage

1. Clean all removed parts with kerosene.
After cleaning the parts with kerosene, store them after applying the hydraulic oil on them.
2. If removed parts are left without cleaning, they may be rusted or damaged by moisture or dust, and may not smoothly work after reassembling.

MEMO

A series of horizontal dashed lines for writing.

8-3-4. Chain bolt - inspection

1. Check for backlash between chain and connecting parts (*).
 ► If there is backlash, replace the chain.
2. Check for damage to the threads. Also check the ring part.

● Inspecting Chain bolt

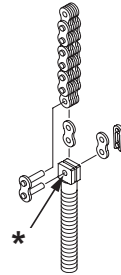

2210168

28CA1/30CA1 2SP-mast

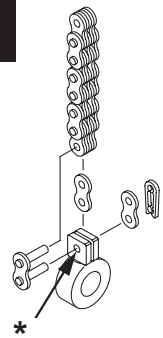

221W037

8-3-5. Chain wheel - inspection

1. Check the outer surface for deformation. Check that bearings rotate properly.

● Inspecting Chain wheel

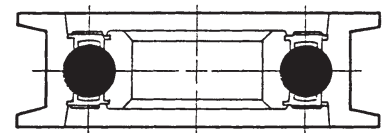

152T025

8-3-6. Hose pulley - inspection

1. Check for wear.

<Specified value> [mm]

Item	Specified dimension[φd]	Wear limit
Hose pulley	φ25.0	25.5

● Inspecting Hose pulley

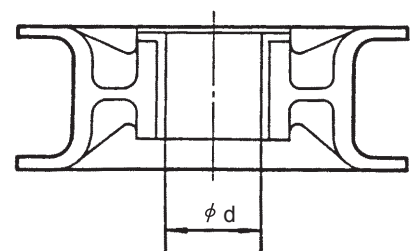

152T026

5. Remove the mounting nuts (*2) of Hydraulic motor to remove Hydraulic motor with Hydraulic pump.
6. Remove the mounting bolts (*3) of Hydraulic pump to remove Hydraulic pump from Hydraulic motor.



Do not disassemble Hydraulic pump. If damaged, replace the assembly.

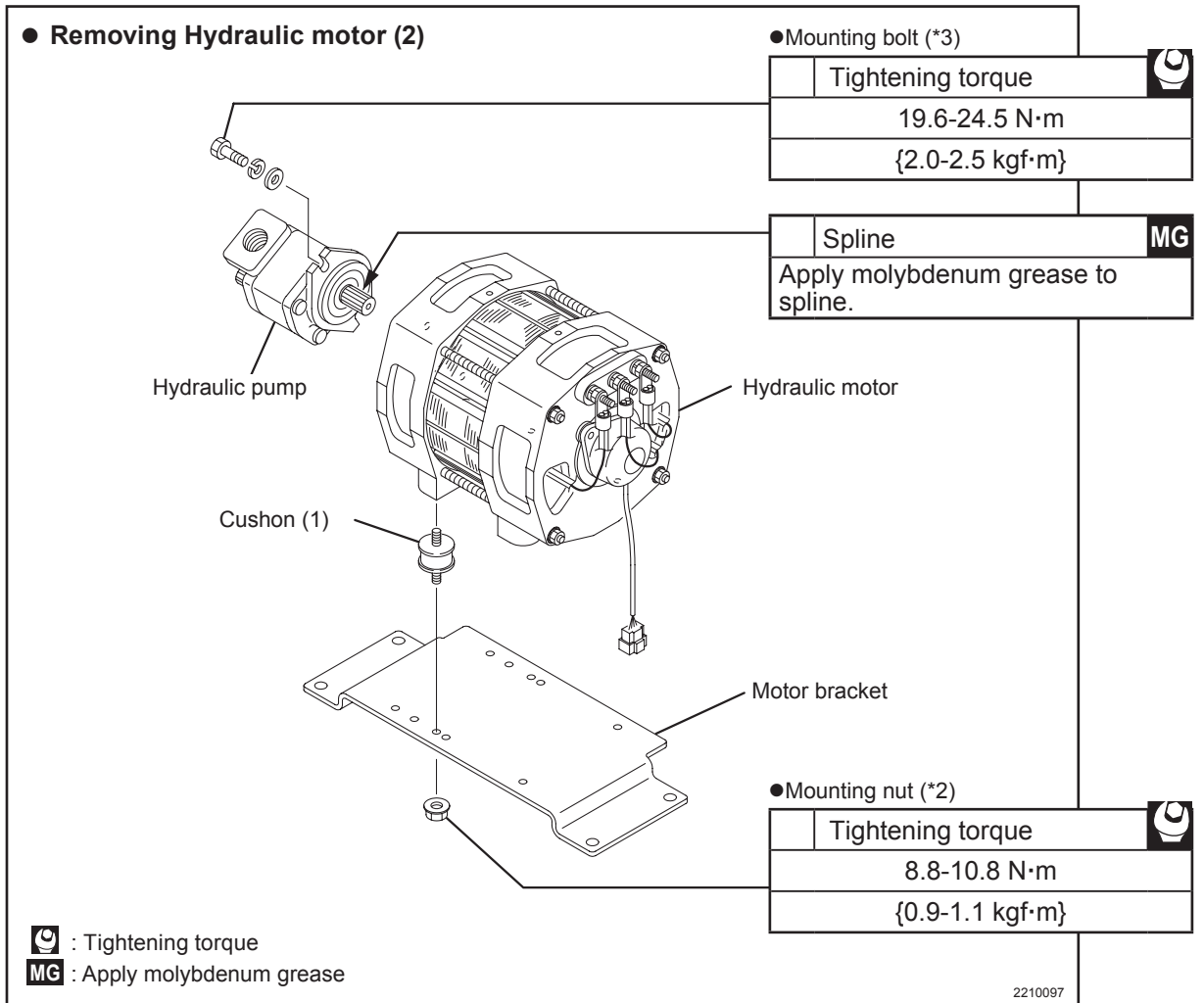

*To install Hydraulic motor, perform the steps to remove it in reverse order.

MEMO

A series of horizontal dashed lines for writing.

CLICK HERE TO **DOWNLOAD** THE COMPLETE MANUAL

- Thank you very much for reading the preview of the manual.
- You can download the complete manual from: www.heydownloads.com by clicking the link below



- Please note: If there is no response to CLICKING the link, please download this PDF first and then click on it.

CLICK HERE TO **DOWNLOAD** THE COMPLETE MANUAL

10c-2. Directional switch - Disassembly and reassembly

10c-2-1. Disassembly and part names

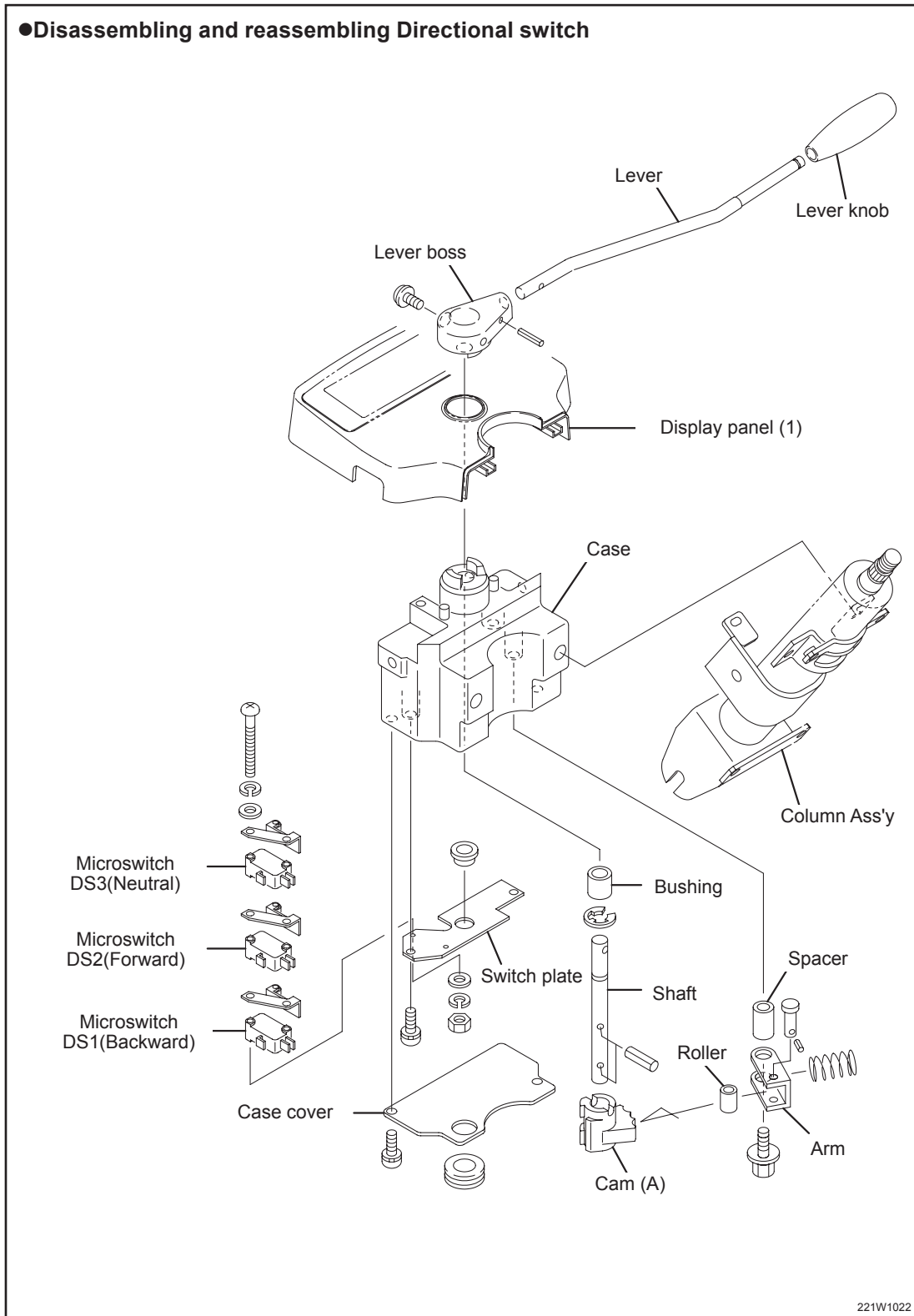

* This illustration shows right lever type (DS100-20).

▶ 2 Battery cell electrolyte specific gravity - measurement

<Measuring with Hydrometer>

1. Check the reading for the line at which tube and electrolyte meet.
2. Check the electrolyte specific gravity readings for each cell and compare the difference among them.

Difference between each cell	within 0.05
------------------------------	-------------

<Adjusting specific gravity>

1. Do an equalizing charge.
2. After doing the equalizing charge, measure the specific gravity of battery cell electrolytes and compare the difference among them.

Convert values to a 20 °C standard temperature and evaluate the results.

<Converting procedure>

1. Measure temperature of electrolyte.



Be sure to use a rod-shaped alcohol thermometer.

2. Measure the specific gravity of electrolyte.
3. Convert the measured values to the values at 20 °C.

[Conversion formula]

$$S_{20} = S_t + 0.0007 (t - 20)$$

S_{20} : Converted specific gravity at 20 °C

S_t : Measured specific gravity.

t : Temperature of electrolyte.

● Measuring Specific gravity

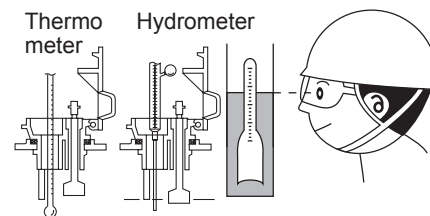

● Conversion table

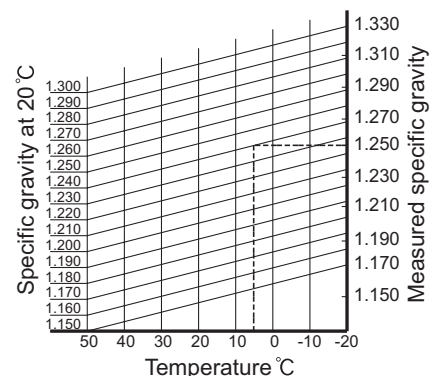

10f-2-2. Battery - cleaning

▶ 1 Cells, Connectors and Terminals

1. Always keep these parts dry by wiping with a cloth or by blow drying with compressed air.
2. Clean rusted parts with a wire brush or sandpaper.

▶ 2 Vent plug

1. Turn Vent plug counterclockwise, and then remove it.
2. With a neutral detergent, clean Vent plug so that Cap and Float are clearly visible.
3. Tighten Vent plug so that Plug is tightly pressed to the electrolyte cell cover.



If the treads of Vent plug are damaged, replace the Vent plug Comp.

<EP10CA1 to 28CA1>

Push the yellow stopper at the midway point of Gas spring, and then close Battery cover.

Closing battery cover

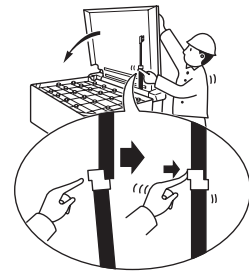

221W082E

After closing Battery cover, apply Cover catch.

<EP30CA1>

Close Battery cover (B). Push the yellow stopper at the midway point of Gas spring, and then close Battery cover (A).

After closing both Battery covers (B) and (A), make sure to lock with Bonnet catch.

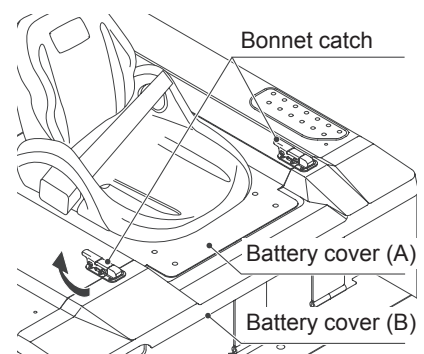

221W1035E

Closing battery cover

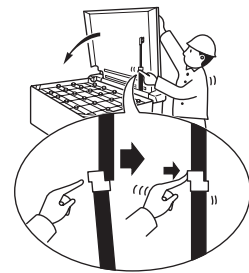

221W082E



When closing the battery cover, be careful not to pinch hands or fingers between the cover and case.



- While charging, do not disconnect receptacle or power supply plugs or the battery plug.
- While charging, do not operate hydraulic levers or Accelerator pedal.
- If the charging is interrupted halfway, make sure to push "STOP" button, and then first disconnect the power supply plug, and then disconnect the battery charging plug.



- Do not touch any part of the charger, plug, or cable with wet hands. The charger operates with high voltage and touching it with wet hands can cause electrical shock.
- Wipe off moisture or wear rubber gloves.



Low temperature conditions may activate the automatic supplementary charge function in order to provide heat insulation for the battery after holiday weekends during the cold season.
 "Standard charging completion fees .. yen" is displayed. (Fee indicator is optional)
 Charging is finished. After pushing "STOP" button, be sure to disconnect Charging plug and AC plug.

10g-4-3. Equalizing charge

The specific gravity of the electrolytes in each cell become unbalanced after repeated recharging. To balance the electrolytes in each cell, you need to charge the battery for slightly longer than normal.

<Automatic equalizing charge>

The control of the built-in charger automatically selects "EQUAL" mode after ten charges.

<Manual equalizing charge>

You need to do an equalizing charge for the following cases.

- If you operate the forklift truck every day, equalize charge every two weeks.
- When the forklift truck has been idle a few days but was not immediately recharged after last operation.
- When the battery is over-discharged.

<Charging procedure >

1. The same as when doing a normal charge, press "EQUAL" button.
"EQUAL" lamp (orange) lights up.
2. After charging, measure the specific gravity of all cells.
➔ See page 183 "10f-2-1.Battery - inspection and adjustment" for the procedure.

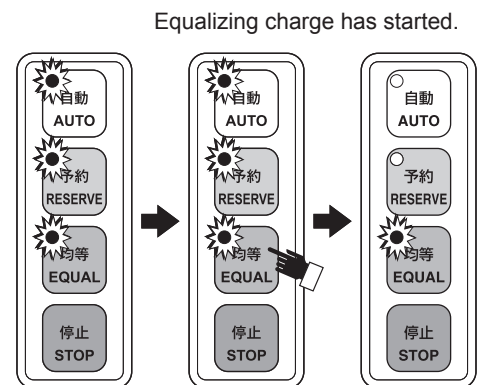

215W1061E



When the specific gravity is 1.26-1.28 at 20 C, the battery is fully charged.



You need to perform the equalizing charge for the following cases.

- Disconnecting the battery plug erases the memory of when charges have been performed, which causes the automatic equalizing charge function to not activate at the proper time. In this case, we recommend equalizing the charge manually.
- Low temperature conditions may activate the automatic supplementary charge function in order to provide heat insulation for the battery after holiday weekends during the cold season. In such cases, automatic battery charge lamp blinks.

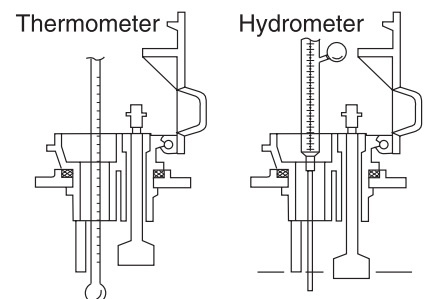

2210243



Be sure to perform the equalizing charge the specified number of times. Otherwise, battery service life will be shortened due to reduced electrolytes and high-temperature operation.

Group	Work	Job	Rate (hour)			
			10CA1-18CA1	20CA1-28CA1	30CA1	
Steering	R/R/I	Steering gear box Ass'y	0.4	0.4	0.4	
		Pitman arm	0.3	0.3	0.3	
		Steering column	0.2	0.2	0.2	
		Joint [after removing Column]	0.1	0.1	0.1	
		Steering wheel	0.2	0.2	0.2	
		Horn contact, Horn cup, Spring	0.1	0.1	0.1	
		Torque sensor	0.5	0.5	0.5	
	Monthly/yearly inspection	Torque sensor voltage measurement	0.1	0.1	0.1	
		Steering wheel play	0.02	0.02	0.02	
		Handle grip damage, looseness in mounting area, backlash	0.02	0.02	0.02	
Monthly inspection	Gear box oil level, fouling, oil leakage, fitting bolt looseness, dropping off	0.1	0.1	0.1		
Steering linkage	R/R/I	Horn contact, Horn cap, Spring	0.1	0.1	0.1	
		Pitman arm	0.3	0.3	0.3	
		Drag link	0.3	0.3	0.3	
		Rod end (1 piece) [after removing Drag link]	0.1	0.1	0.1	
		Actuator	0.6	0.6	0.6	
	Adjust	Turning radius	0.3	0.3	0.3	
Wheel brake	R/R/I	Repair kit (1 set) [after removing Brake drum]	0.2	0.2	0.2	
		Brake shoe Ass'y (2 pieces with one side) [after removing Brake drum]	0.5	0.5	0.5	
		Shoe return spring (2 pieces with one side) [after removing Brake drum]	0.1	0.1	0.1	
		Adjuster Ass'y (1 piece) [after removing Brake drum]	0.1	0.1	0.1	
		Adjuster cable [after removing Brake drum]	0.1	0.1	0.1	
		Parking brake cable (one side) [after removing Brake drum]	0.4	0.4	0.4	
		Brake Ass'y (1 piece) [after removing Brake drum]	0.6	0.6	0.6	
		Adjust	Brake (including Air bleeding)	0.5	0.5	0.5
		Monthly inspection	Shoe clearance	0.5	0.5	0.5
	Lining peeling, damage, wear Anchor pin corrosion Spring permanent set Drum crack, damage, wear, and fitting bolt looseness Backplate crack, damage, deformation, fitting bolt looseness					
	Monthly/yearly inspection	Brake test (Stopping distance and Brake pull)	0.1	0.1	0.1	

Reproduction prohibited

First printing : July 2015

2nd printing : September 2016

Issued by: Mitsubishi Nichiyu Forklift Co., Ltd.

Edited by: Overseas Customer Service Division
Mitsubishi Nichiyu Forklift Co., Ltd.

2- 2. Indication of display

When the key switch is turned on, the self-diagnosis function checks the control system and displays "MONITORING OK" if no problems are found.

The "Read operator's manual" and "Fasten seat belt" icons flash three times as a caution to the operator.

After 2 or 3 seconds, the normal screen is displayed. If any abnormalities are detected, an error message is displayed.

If a detailed message is displayed, or several messages are displayed, they scroll in order from right to left on the display.



If you travel the forklift truck or operate its hydraulics within 3 or 4 seconds after turning on the display, the normal screen displays once the start-up monitoring functions are finished.

When the key switch is turned on.

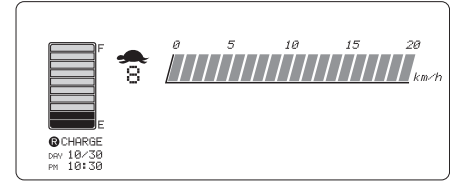

↓ After 0.5 seconds

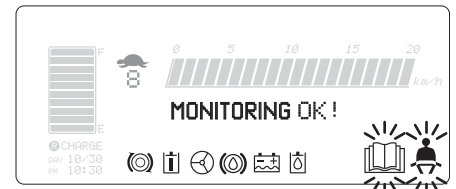

↓ After 2 or 3 seconds

Normal screen

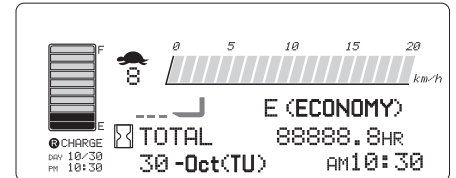

215T1052E

Mode select button



If you select a mode during travel/hydraulic operation, the display returns to the normal screen.

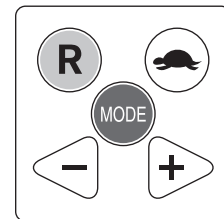

121T188

Mode selection

Press button.



Pre-set time charge screen
● Set the battery charge start time

Press button.
(Release within 3 seconds.)



Mode select screen
● Slow speed mode
● Travel mode
● Hour meter / odometer selection
● Display mode
● Regeneration (Neutral) mode

Press button.
(For at least 3 seconds.)



Date / time setting screen
● Set date and time.

Press button.



Electricity consumption meter
(built-in charger only)
Hour meter screen
● Displays three hour meters:
travel, hydraulic, and total hours.

See EP-CA1 Operator's manual
••• "How to charge the battery (By built-in charger)" of "5. Battery and charger".

••• See page 11
"2-4. Mode selection".

See page 16
••• "[7] How to set the date and time" of 2-4.

••• See page 7
"7. Hour meter" of 2-3.

Normal screen and meter mode screen

When set to display hour meter (HR)

When set to display odometer (km)

When set to display load weight (kg)

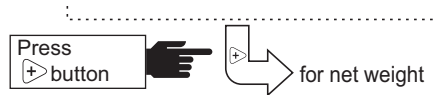
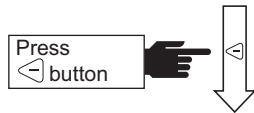
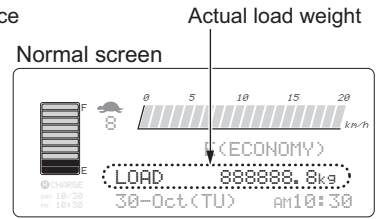
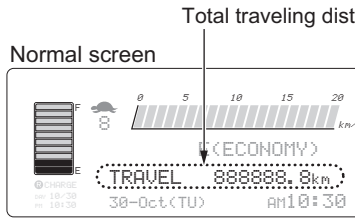
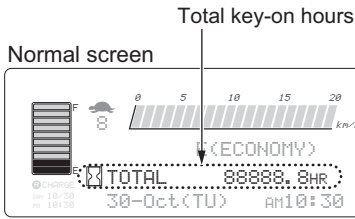

Electricity rate screen

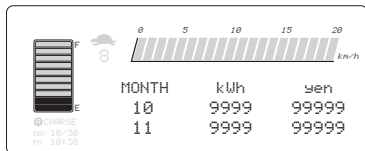
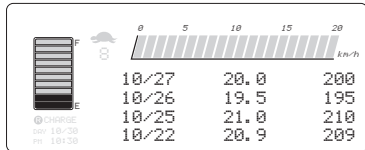
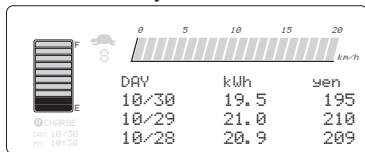

Reduced CO2 amount screen

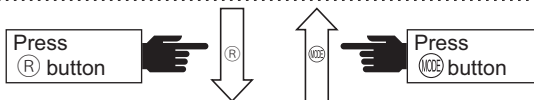
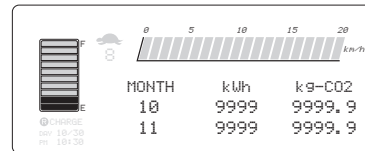
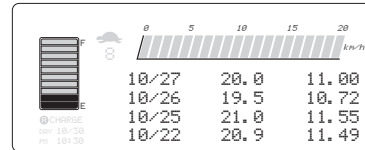
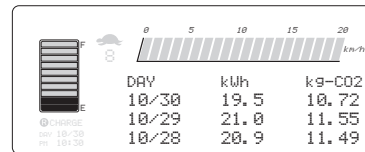

Confirmation screen

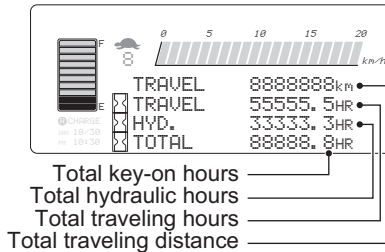

Confirmation screen

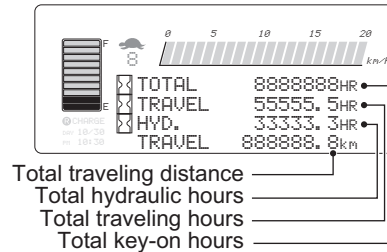

* 5 seconds after displaying any of the above screens, the display automatically returns to the normal screen. You can also return immediately to the normal screen by pressing < or > buttons.

RS	Functions	Remarks
5	Language selecting	Select language (Six languages)
6	Option setting	Set optional functions
7	Voltage, motor current, transistor temperature check	TRV/HYD/EPS
8	RAM and I/O memory data check	
9	Error history memory 1	Check error history (latest 10 cases)
	Error history memory 2	Check error history (all past cases)
A	Battery voltage / overload weight setting	Voltage settings for capacity standards overload weight value setting, Overload warning buzzer setting
B	Reduce turning speed	1 - 16
	Electricity consumption/ reduced CO2 setting	Electricity rate: 1.0 - 50.0 [Japanese Yen/kWh] Reduced CO2 amount: 0.10 - 1.00 [kg/kWh]
C	AOS setting 1	Set lift end / tilt end and other settings
D	AOS setting 2	Check lever switch
E	Memory initialize	Initialize error history memories.
F	Normal screen 2	No errors are displayed on the screen of RS0

* See "4-2. Adjustment Standards List for EP-CA1 series" on page 27 for parameters.

<How to check hydraulic motor current>

NOTE

Before checking, adjust battery voltage.
 → See "5-2-2. Battery voltage calibration".

1. Set the rotary switch RS on the EPS controller to "7".
2. Turn on the key switch. The following screen appears.
3. When you press \rightarrow or \leftarrow button, HYD flashes.

● EPS controller



Set RS to "7".

When the rotary switch mode is set to OFF in the service setting,

ROTARY SW OFF/ON

Press \rightarrow or \leftarrow button for at least 3 seconds while also pressing MODE button.

● Voltage, current, and temperature screen.

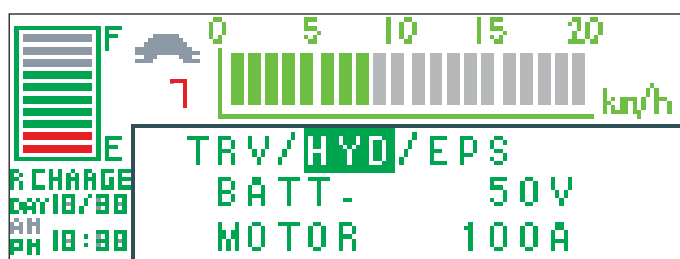

"HYD" is short for "Hydraulic" circuit. Here, the screen shows hydraulic motor current and battery voltage. Make sure that the motor current reads "000A" when all hydraulic levers are released and the hydraulic motor is stationary.

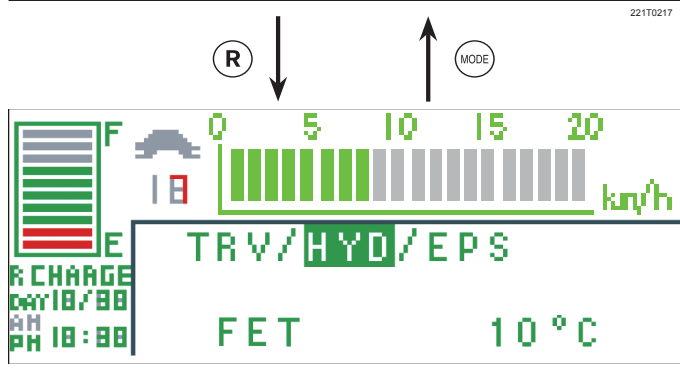

This screen shows the temperature of FET module for the hydraulic motor.

4. Without operating the lift lever, check that hydraulic motor current (MOTOR) is 000A.
5. Fully pull up the lift lever until it reaches lift relief position (lift end-of-stroke) and hold for 10 seconds.
6. Under these conditions, check that the display indicates a hydraulic motor current (MOTOR) within $\pm 20A$.

5-2-11. Pitching control adjustment

<How to adjust pitching control>

1. Set the rotary switch RS on the EPS controller to "3".
2. Turn on the key switch. The following screen appears.

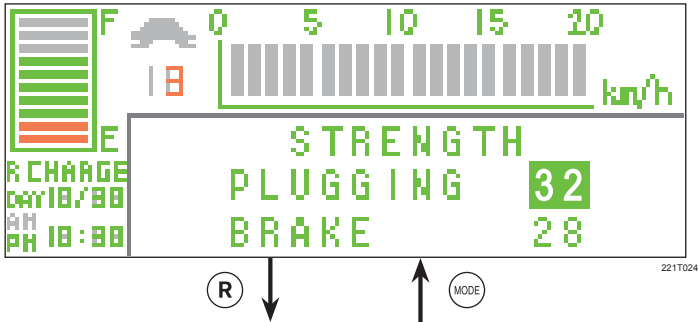

● EPS controller

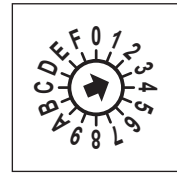

Set RS to "3".

When the rotary switch mode is set to OFF in the service setting,

ROTARY SW OFF/ON

Press \rightarrow or \leftarrow button for at least 3 seconds while also pressing MODE button.

● Pitching control setting screen

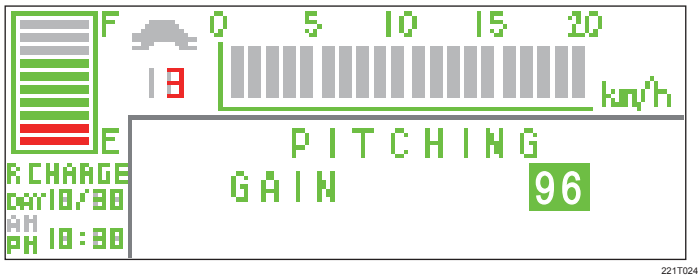

3. Press R button 2 times. The pitching control setting screen appears.
4. Press \rightarrow and \leftarrow buttons to select one of the following control values.

Applicable model	Control value	Initial value
EP10CA1/14CA1/15CA1/ 18CA1/30CA1	32/64/96/128	96
EP20CA1/25CA1/28CA1	32/96/128/192	128

Press \rightarrow button to increase the value.

Press \leftarrow button to decrease the value.

5. After changing the value, return the rotary switch RS on the EPS controller to "0".



To reflect this adjustment, turn the pitching control setting ON.

➡ Refer "[6]Pitching control setting" of "2.4 Setting modes" (page 15).



This function controls lateral movement of load and does not control lateral movement of frame. The effect will vary depending on work conditions, such as road surface, traction, speed, and load.

If adjusting pitch control does not produce a significant change, turn off pitching control and check lateral movement under those conditions, and then select whichever setting has the best result.

5-2-18. Hour meter check

The hour meter circuit is not connected when the forklift truck is shipped out from the factory.

Before delivering the truck to the customer, you need to connect the hour meter circuit in order for it to work.

<How to check the hour meter circuit>

1. Connect the following connector terminals.

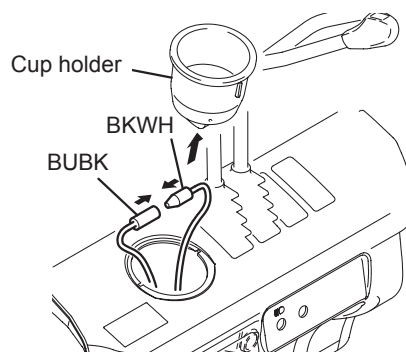

221T0231

NOTE

Location of connector terminals

:behind the main front panel around the cup holder.

Wire colors

: Blue/black (BUBK) and Black/white (BKWH).

2. Confirm that the hourglass symbol on the display flashes when the key switch is turned on.

If HOUR METER mode "2" option is selected, confirm that the hourglass symbol on the display flashes when traveling or operating hydraulics.

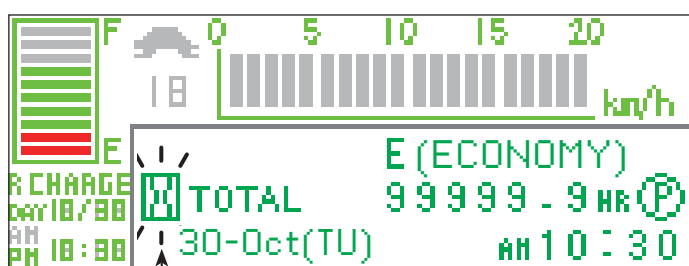

CAUTION

- After checking, be sure to disconnect the circuit until you deliver the forklift to the customer.
 - If you want the display to show Actual operation, in HOUR METER optional setting, select "2".
- ➔ See "5-2-14.Optional function check and settings" on page 48.



215T0307E

Hourglass (flashing)

Standard : Key SW ON	 (White)
Option : Work	 (Black)

5-4. Motor

5-4-1. Traction and Hydraulic motor insulation- inspection

Measure the insulation between terminals and stator comp. with the Megger.

<Resistance>

Measuring device	Specific resistance
Megger	0.5 MΩ or greater (DC500V)

<Measuring procedure>

1. Apply the earth probe (negative [-]) of the Megger to the stator comp.
2. Apply the line probe (positive [+]) of the Megger to each terminal. (U, V and W)

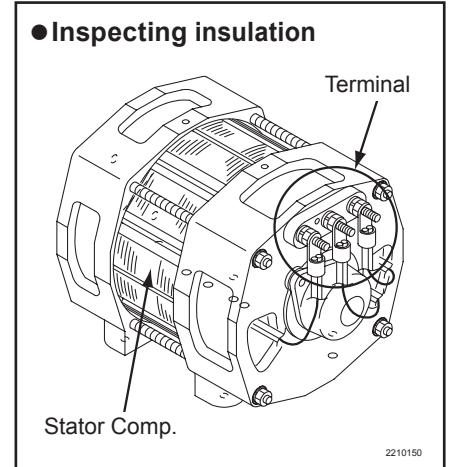

5-4-2. EPS motor - inspection

Inspect with the following procedure after assembling.

▶ 1 Abnormal noise and spark

- Operate the motor. Then make sure that abnormal noise is not heard and sparks of brushes are not seen.

▶ 2 Inspection of insulation

Measure the insulation between terminals in the connector and the end cover with the Megger.

<Resistance>

Measuring device	Specific resistance
Megger	0.1 MΩ or greater (DC500V)

<Measuring procedure>

1. Apply the earth probe (negative [-]) of the Megger to the yoke.
2. Apply the line probe (positive [+]) of the Megger to each terminal of connector plug.

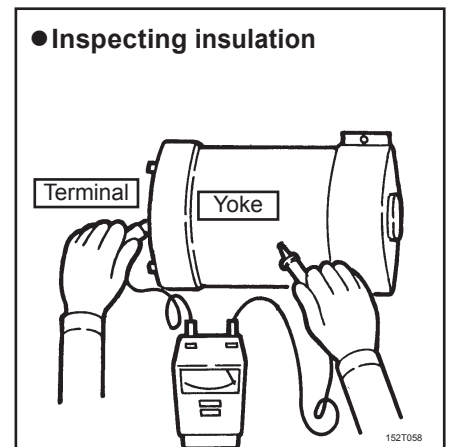

Error Message	Possible Cause	Remarks
G61: *FAIL BUS SYSTEM-TRAVEL*	Abnormal communication between traveling displays	*TURN OFF KEY SWITCH*
G62: *FAIL BUS SYSTEM-HYD.*	Abnormal communication between hydraulic displays	*TURN OFF KEY SWITCH*
G63: *FAIL BUS SYSTEM-AOS*	Abnormal communication between AOS displays	*TURN OFF KEY SWITCH*
G64: *FAIL BUS SYSTEM-PS*	Abnormal communication between HPS displays	*TURN OFF KEY SWITCH*
FAIL OPERATION	During travel or hydraulic trip	Display with error
TURN OFF KEY SWITCH	During critical defects	Display with error
REDUCE THE LOAD	Overload	When overload is entered
REFILL HYDRAULIC OIL	Fork oil	When fork oil sensor is entered
REFILL BRAKE OIL	Brake oil	When break oil is entered
REPLENISH REFINED WATER FOR BATTERY	Refilling refined water	For battery fluid level sensor input
CHARGE THE BATTERY	Request for battery charging	When battery capacity is low
RELEASE PARKING BRAKE	Attempt to travel when the parking brake is ON	
AOS FAIL OPERATION	When AOS emergency stop switch is pressed	
RACK MISSET	When the order of position of lifting height is incorrect	
EEPROM ERROR	EEPROM data reading and writing defect	
RELEASE ACCEL TO NEUTRAL	Took a seat while in directional set state	
	In directional set state when the key switch is turned ON	
PUT DIRECTIONAL LEVER INTO NEUTRAL	Took a seat during accelerator ON state	
	Accelerator ON when the key switch is turned ON	
OFF HYD.LEVER TO NEUTRAL	Hydraulic lever is ON when the key switch is turned ON	When hydraulic CPU is in a neutral safety state
PLEASE BE SEATED	When an operator is away from the seat	
FASTEN SEATBELT	Operator does not fasten seatbelt when they sit on seat	Only Australian standard
REFASTEN SEATBELT	Seatbelt is fastened when key switch is turned on.	Only Australian standard
	Seatbelt is fastened when operator sit on seat.	

●I/O port table (2)

Address	Bit	IN/OUT	Contents	Remarks
W0008	16	IN	Rotary switch 1	Truck model selection
	17	IN	Rotary switch 2	Truck model selection
	18	IN	Rotary switch 3	Truck model selection
	19	IN	Rotary switch 4	Truck model selection
	20	IN	Spare input 3	0 - 5 V input
	21	IN	Spare input 1	0 - 5 V input

W000A	0	IN	Detect current phase U	$2.5V \pm 1.75 = \pm 700 A$
W000C	1	IN	Battery voltage	0 - 5 V = 0 - 55 V
W000E	2	IN	Lift lever potentiometer 1	0 - 5 V
W0010	3	IN	Lift lever potentiometer 2	0 - 5 V
W0012	4	IN	Detect current phase W	$2.5V \pm 1.75 = \pm 700 A$
W0014	5	IN	FET thermistor	0 - 5 V
W0016	6	IN	Tilt level potentiometer	0 - 5 V
W0018	7	IN	Tilt lever potentiometer	0 - 5 V
W001A	8	IN	Load sensor	0 - 5 V
W001C	9	IN	Tilt lever potentiometer	0 - 5 V
W001E	10	IN	Attachment 2 valve current	0 - 5 V
0020	11	IN	Reach lever potentiometer	0 - 5 V
0022	12	IN	Lift valve current	0 - 5 V
0024	13	IN	Tilt valve current	0 - 5 V
0026	14	IN	Reach valve current (Attach 1)	0 - 5 V
0028	15	IN	Reach lever potentiometer	0 - 5 V

W002A	2	IN	Lift rotary encoder	Count
-------	---	----	---------------------	-------

H : High=1 L : Low=0

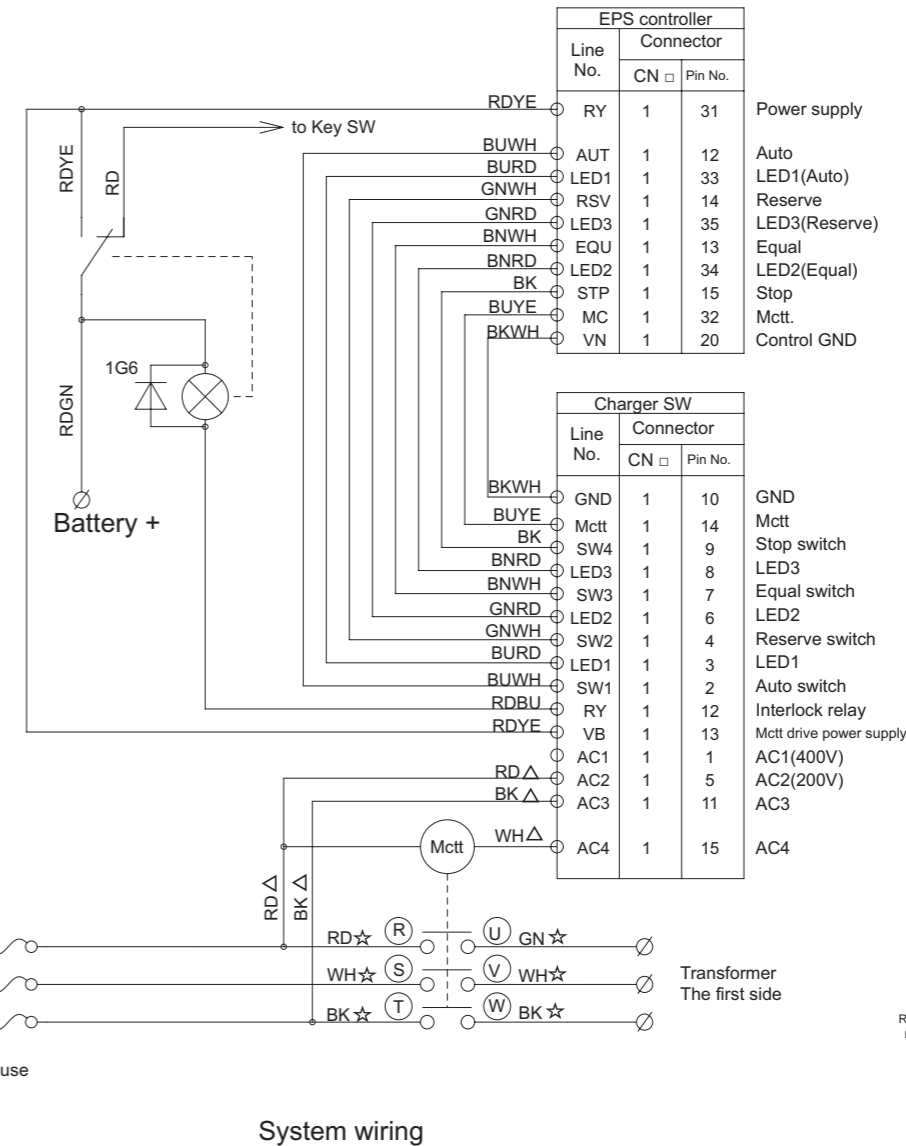
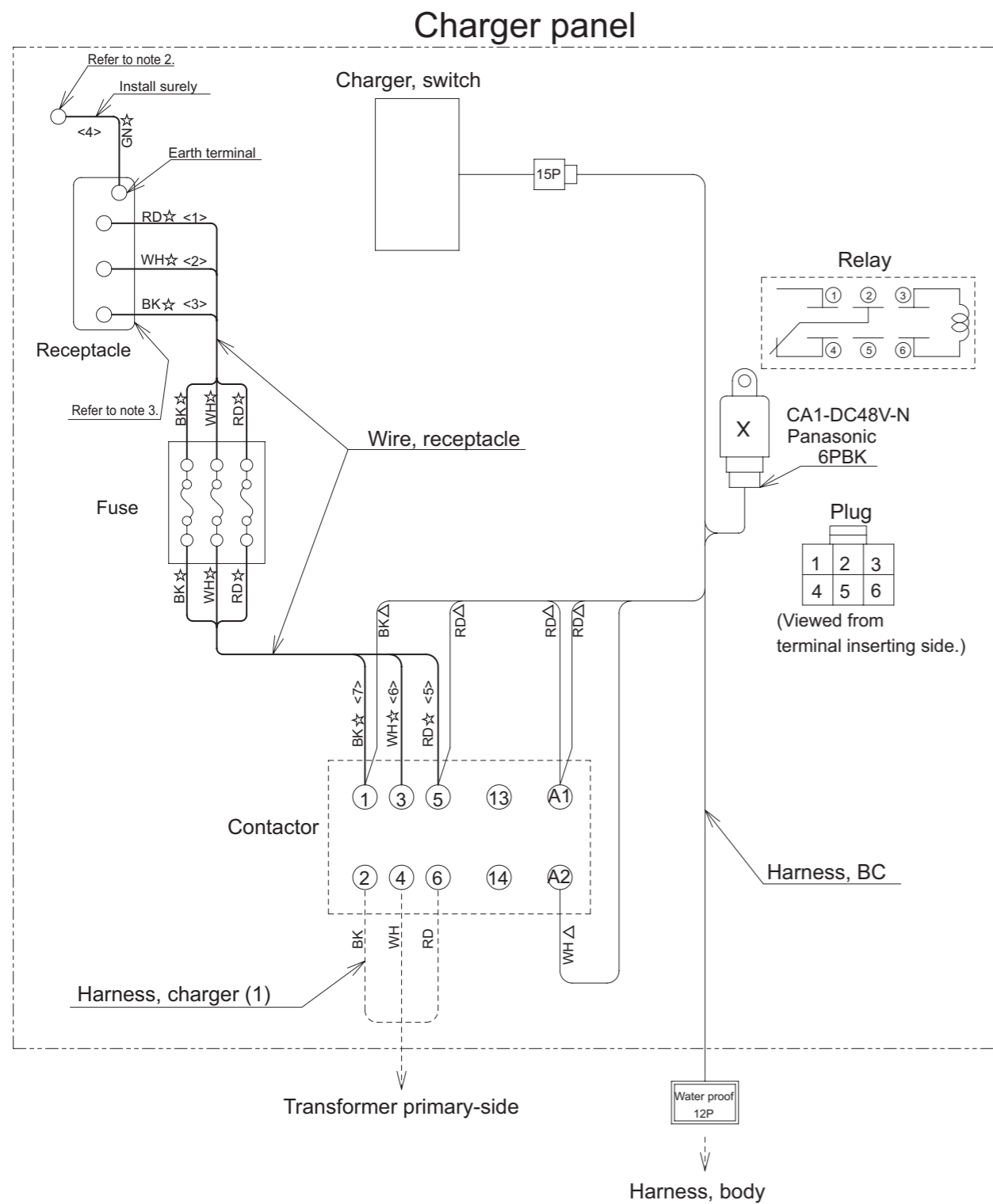

NOTE)

1. Electric wires (without indication)

- △ : AVS/AVSS 0.5 mm²
- ☆ : KIV 0.75 mm²
- ☆ : KIV 3.5 mm² (5.2-7.0 kVA) / KIV 5.5 mm² (10.0/12.0 kVA)

2. Install in the panel and set up earth terminal (GN) of the receptacle as shown in the figure below. Make sure that there is continuity between the earth terminal and the charger panel after assembling.

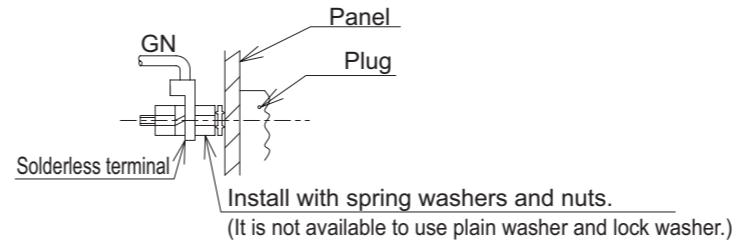

3. Connect the electric wire with the receptacle as follows.

· A naked electric wire is 10±1mm.
 · Tightening torque of round head screw is 0.98-1.18N·m.

BC (200V) **7-7.**

Wiring EP10CA1-30CA1/EP10HCA1-25HCA1 **7-7-1.**

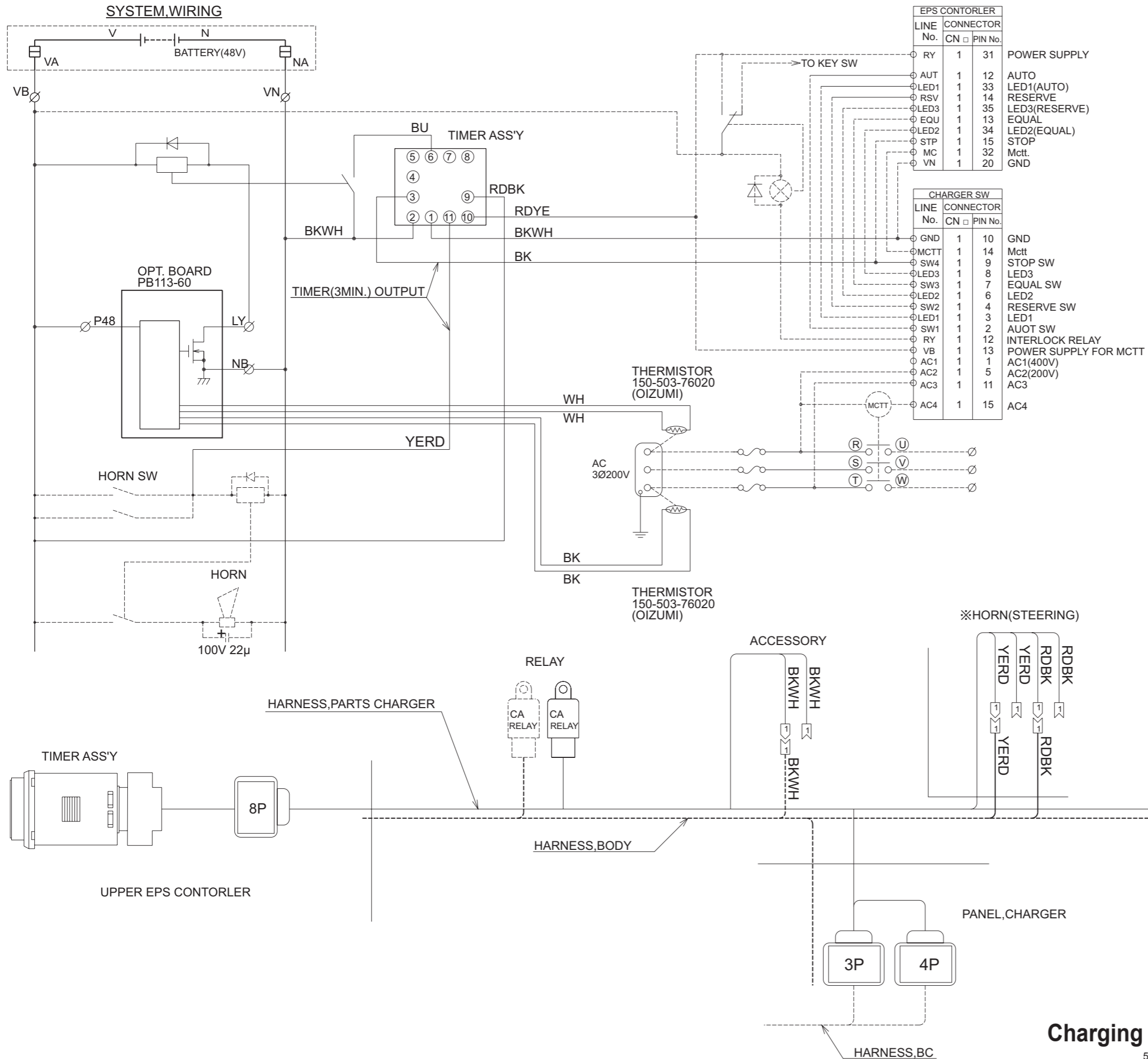

HARNES COLOR					
BK	BLACK	YE	YELLOW	BN	BROWN
WH	WHITE	GN	GREEN	BU	BLUE
RD	RED				

<CONTENT OF OPERATION>
 IF THERMISTOR BECOMES ABNORMAL TEMPERATURE(109°C),
 A CHARGE STOP WILL BE CARRIED OUT AND A HORN WILL SOUND
 FOR 3 MINUTES BY A TIMER.

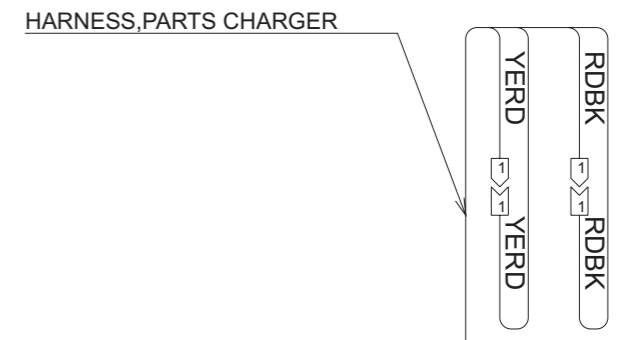
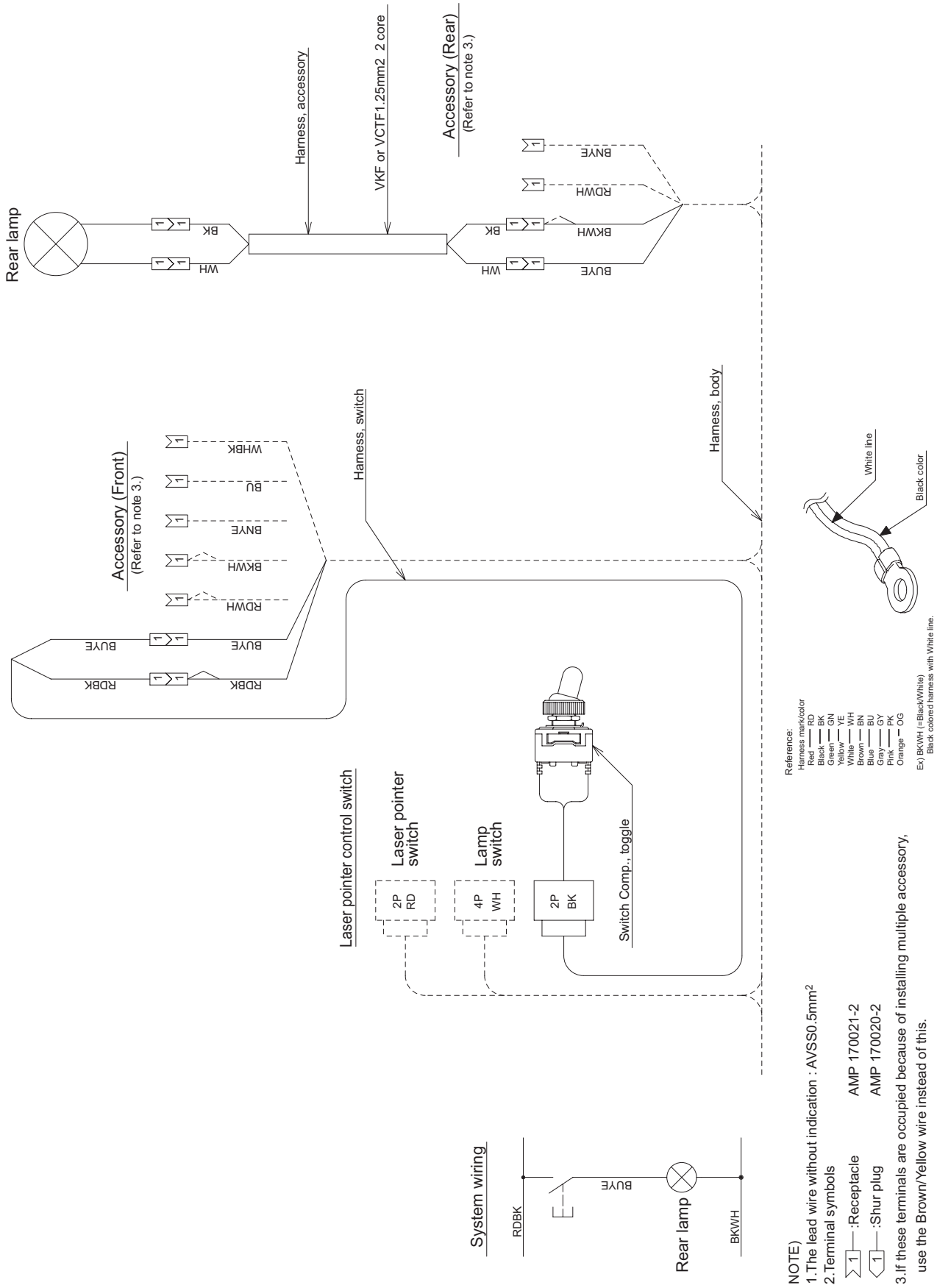

FIG.1

WHEN DO NOT NEED THE MOVEMENT OF HORN,
 CONNECT WIRING OF THE HARNESS SIDE (YERD AND RDBK) LIKE FIG 1.

Wiring, warning **7-11.**

Charging overheating warning (All models) **7-11-1.**



Wiring, lamp (2) 7-16.

Rear lamp (All models) 7-16-2.

54002-01910-0E

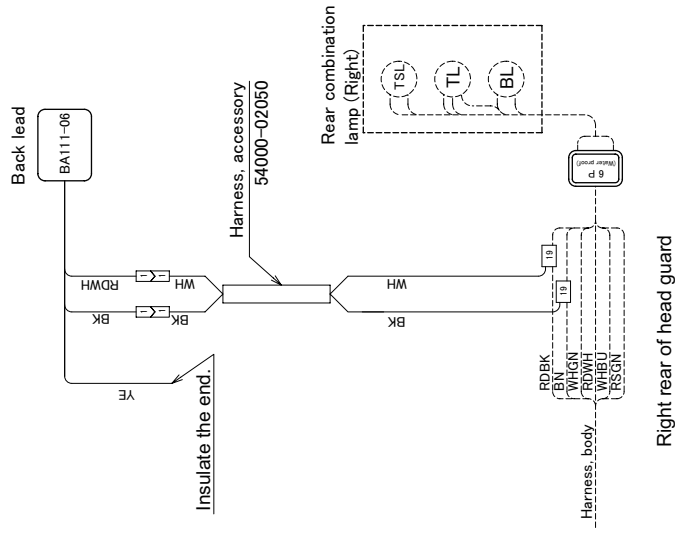
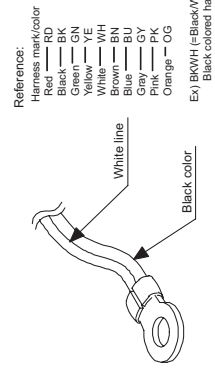
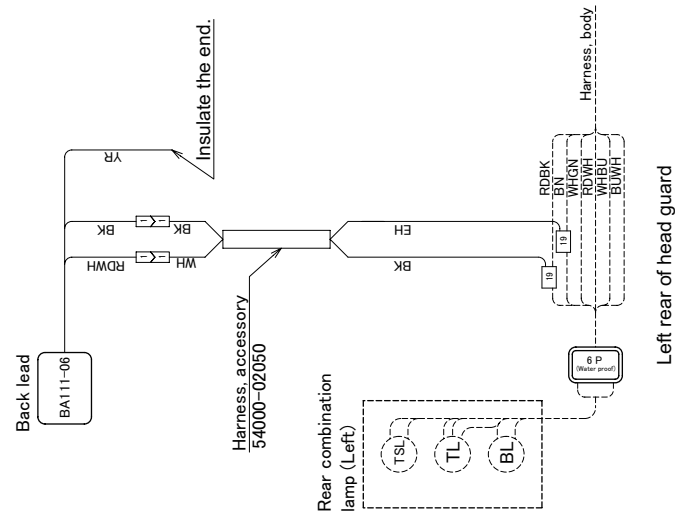
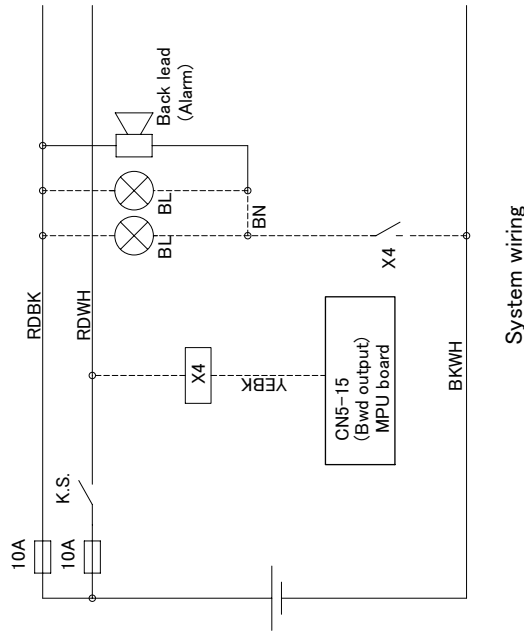

<Note>

3. Terminal symbols

—: Shur plug AMP 170020-2

—: Shur receptacle AMP 170021-2

—: Terminal, splicing AMP 171425-1

Wiring, back lead **7-20.**

Back lead (All models)

7-20-1.

CLICK HERE TO **DOWNLOAD** THE COMPLETE MANUAL

- Thank you very much for reading the preview of the manual.
- You can download the complete manual from: www.heydownloads.com by clicking the link below



- Please note: If there is no response to CLICKING the link, please download this PDF first and then click on it.

CLICK HERE TO **DOWNLOAD** THE COMPLETE MANUAL