



# Service Manual

## Chassis & Mast

### MC/FC

GP15N	AT34A-00012-49999	GP18NM	AT34B-00012-49999
GP18N	AT34A-00012-49999	GP20CNM	AT34B-50012-99999
GP20CN	AT34A-50012-99999	GP20NM	AT17F-00012-49999
GP20N	AT35A-00012-49999	GP25NM	AT17F-00012-49999
GP25N	AT35A-00012-49999	GP25NMA	AT17F-00012-49999
GP28N	AT36A-00012-49999	GP28NM	AT36B-00012-49999
GP30N	AT13G-00012-49999	GP30NM	AT13H-00012-49999
GP33N	AT13G-50012-99999	GP33NM	AT13H-50012-99999
GP35N	AT13G-50012-99999	GP35NM	AT13H-50012-99999
DP20N	AT18E-00012-49999	DP20NM	AT18D-00012-49999
DP25N	AT18E-00012-49999	DP25NM	AT18D-00012-49999
DP28N	AT37B-00012-49999	DP25NMA	AT18D-00012-49999
DP30N	AT14G-00012-49999	DP28NM	AT37A-00012-49999
DP33N	AT14G-50012-99999	DP30NM	AT14F-00012-49999
DP35N	AT14G-50012-99999	DP33NM	AT14F-50012-99999
GP15NM	AT34B-00012-49999	DP35NM	AT14F-50012-99999

CLICK HERE TO **DOWNLOAD** THE COMPLETE MANUAL

- Thank you very much for reading the preview of the manual.
- You can download the complete manual from: [www.heydownloads.com](http://www.heydownloads.com) by clicking the link below



- Please note: If there is no response to CLICKING the link, please download this PDF first and then click on it.

CLICK HERE TO **DOWNLOAD** THE COMPLETE MANUAL

# TABLE OF CONTENTS

## CHAPTER 1 GENERAL INFORMATION

---

1.1 Model View.....	1 - 1
1.1.1 MC Model.....	1 - 1
1.1.2 FC Model.....	1 - 2
1.2 Truck Models Covered.....	1 - 3
1.3 Serial Number Locations.....	1 - 5
1.4 Dimensions.....	1 - 7
1.5 Technical Data.....	1 - 8
1.6 Performance.....	1 - 10

## CHAPTER 2 COOLING SYSTEM

---

2.1 Specifications.....	2 - 1
2.1.1 Specifications.....	2 - 1
2.1.2 Structure.....	2 - 2
2.2 Removal and Installation.....	2 - 4
2.2.1 Fan Belt Removal.....	2 - 4
2.2.2 Suggestions for Removal.....	2 - 4
2.2.3 Installation.....	2 - 5
2.3 Inspection and Adjustment.....	2 - 6
2.3.1 Fan Belt Inspection.....	2 - 6
2.3.2 Fan Belt Tension.....	2 - 6
2.3.3 Connecting Hoses.....	2 - 6
2.3.4 Unit Layout.....	2 - 7
2.3.5 Coolant.....	2 - 8
2.3.6 Radiator Cap.....	2 - 8

## CHAPTER 3 ELECTRICAL SYSTEM

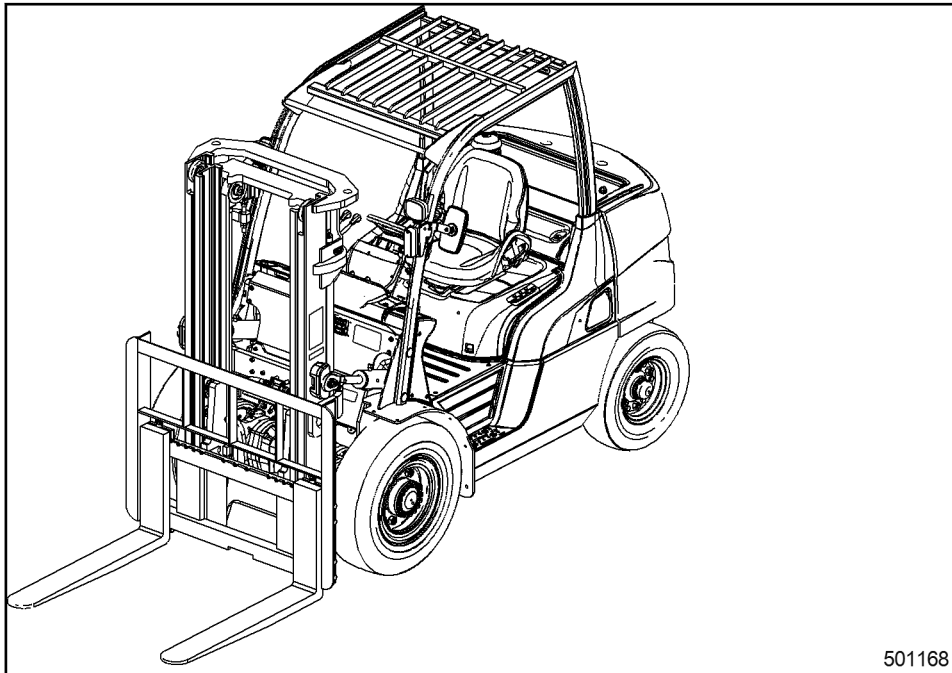
---

3.1 Chassis Electrical Components and Wiring Outline.....	3 - 1
3.1.1 D04EG Engine Model.....	3 - 1
3.1.2 K21/25, K21/25E, and S4S Engine Models.....	3 - 3
3.1.3 Electrical Components and Wiring Diagram of Each System.....	3 - 4
3.2 Console Box.....	3 - 15
3.2.1 Outline of Console Box.....	3 - 15
3.2.2 Removing Meter Panel.....	3 - 16
3.3 Main Electrical Components.....	3 - 19
3.3.1 Meter Panel.....	3 - 19
3.3.2 Key Switch (Anti-Restart Switch).....	3 - 20
3.3.3 Light Switch and Turn Signal Switch.....	3 - 22
3.3.4 Direction (FNR) Switch.....	3 - 23
3.3.5 Horn.....	3 - 24
3.3.6 Tank Unit.....	3 - 25
3.3.7 Brake Fluid Sensor.....	3 - 25
3.3.8 Stop Light Switch.....	3 - 26
3.3.9 Thermostat for Engine Coolant Temperature (K21/25 Engine Model and S4S Engine Model).....	3 - 26
3.3.10 Thermostat (T/C Oil).....	3 - 27

## Chapter 1 GENERAL INFORMATION

### 1.1 MODEL VIEW

#### 1.1.1 MC MODEL



Truck model		Class	3 ton class					
		Gasoline engine model	GP30N	-	GP33N	-	GP35N	-
		Diesel engine model	-	DP30NM DP30N	-	DP33NM DP33N	-	DP35NM DP35N
Capacity		kg (lb)	3000 (6613.9)		3300 (7275.2)		3500 (7716.2)	
Load center		mm (in.)	500 (19.7)					
Lift speed	Loaded	mm/s (fpm)	500 (98.4)	490 (96.5)	500 (98.4)	490 (96.5)	420 (82.7)	410 (80.7)
	Unloaded	mm/s (fpm)	520 (102.4)	510 (100.4)	520 (102.4)	510 (100.4)	440 (86.6)	430 (84.6)
Travel speed (Powershift model)	Loaded	km/h (mph)	17.0 (10.6)	16.0 (9.9)	17.5 (10.9)	16.5 (10.3)	17.5 (10.9)	16.5 (10.3)
	Unloaded	km/h (mph)	18.0 (11.2)	17.5 (10.9)	18.5 (11.5)	18.0 (11.2)	18.5 (11.5)	17.5 (10.9)

Table 1-7.

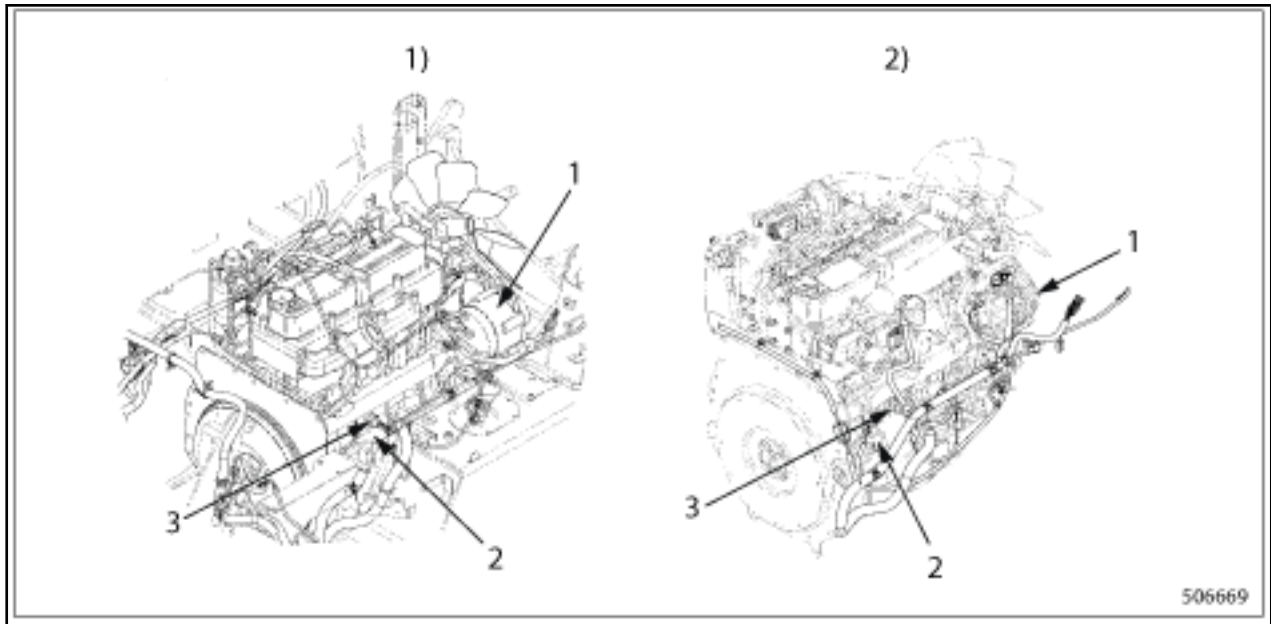


1. GLOW PLUG

1) S4S ENGINE MODEL

2) D04EG ENGINE MODEL

**Engine**



**Figure 3-13.**

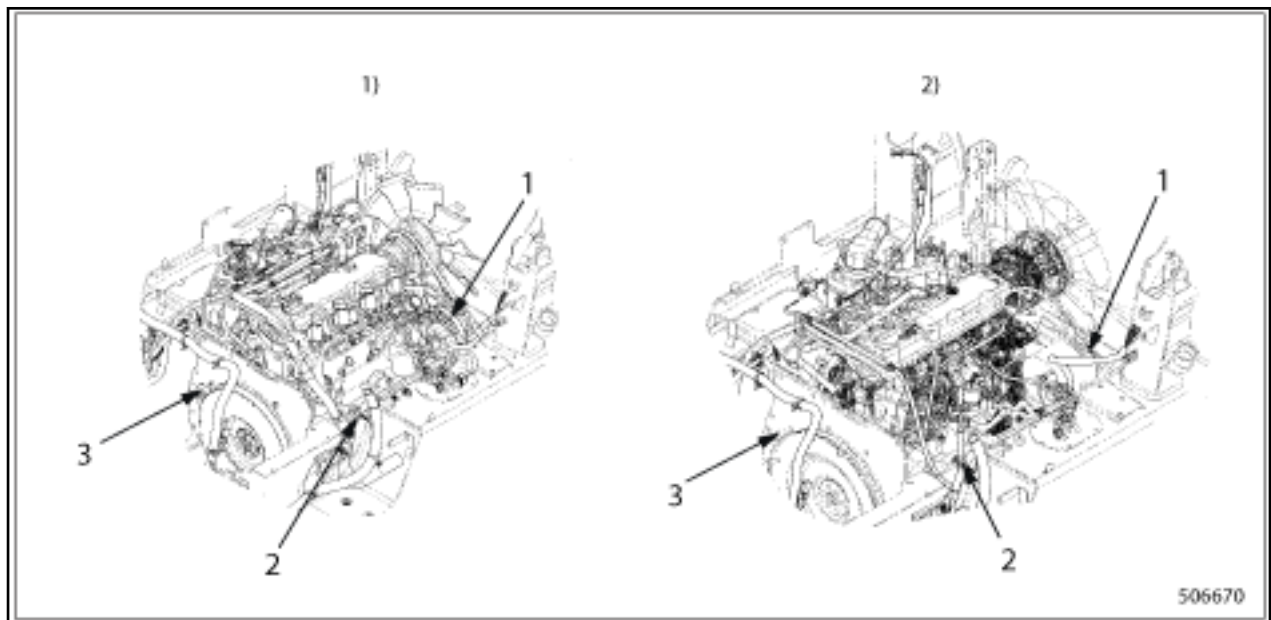
1. ALTERNATOR

3. OIL PRESSURE SWITCH

2. STARTER

1) S4S ENGINE MODEL

2) D04EG ENGINE MODEL



**Figure 3-14.**

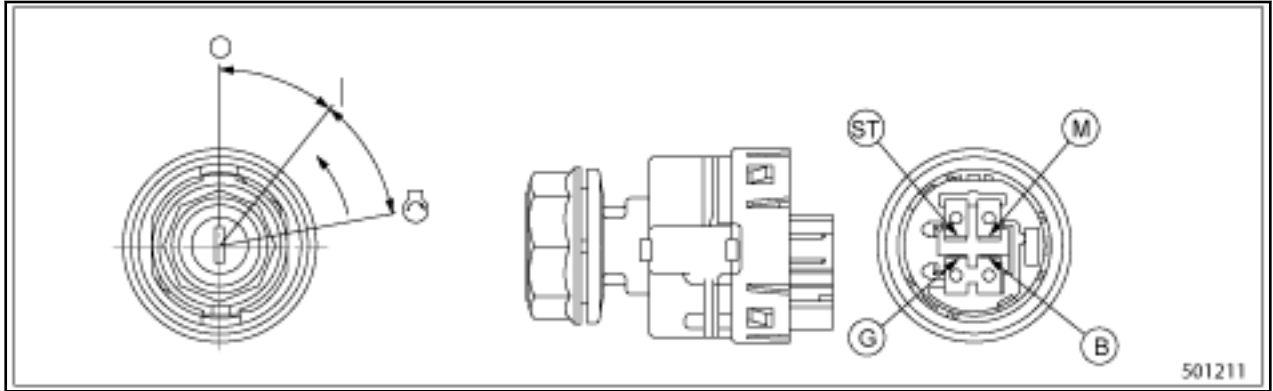


Figure 3-26.

Connection table

Terminal	G	B	M	ST	Key insertion/ removal
OFF					Yes
ON (when operating)		○·····	····○····		No
START (when starting engine)		○·····	····○····	········○	No

Table 3-3. For gasoline engine models (12V)

Terminal	G	B	M	ST	Key insertion/ removal
OFF	○·····	····○			Yes
ON (when operating)	○·····	····○----	-----○		No
START (when starting engine)	○·····	····○----	-----○----	-----○	No

Table 3-4. For diesel engine models (12V)

**NOTE:** Dotted line between terminals of G and B shows externally coupled circuit.

4. Meter panel, Speed meter, Speed alarm light, Input unit, Output unit, Gateway controller	10A	15. BLANK	-
5. Flasher relay, Backup relay, Backup light, Backup alarm, Turn signal light, Revolving light	15A	16. ECM, ECU	30A
6. BLANK	-	17. Fuse puller	
7. BLANK	-	18. BLANK	-
8. Working light	15A	19. Alternator	100A
9. BLANK	-	20. Battery	100A
10. SPARE POWER SUPPLY	20A	21. BLANK	-
11. Wiper, Washer	15A	22. BLANK	-

**Table 3-13. D04EG engine model (Continued)**

1. Fuse		12. Head light	15A
2. VCM	20A	13. Horn	10A
3. QGS	10A	14. Stop light	10A
4. Meter panel	10A	15. EGI	30A
5. Backup/Others	15A	16. EGI	30A
6. Spare	20A	17. Fuse puller	-
7. Spare	30A	18. SBF Glow	50A
8. Working light	15A	19. SBF Alternator	100A
9. ETC	15A	20. SBF Battery	100A
10. A/C	20A	21. Spare	15A
11. Wiper	15A	22. Spare	10A

**Table 3-14. K21/25, K21/25E, and S4S engine models**

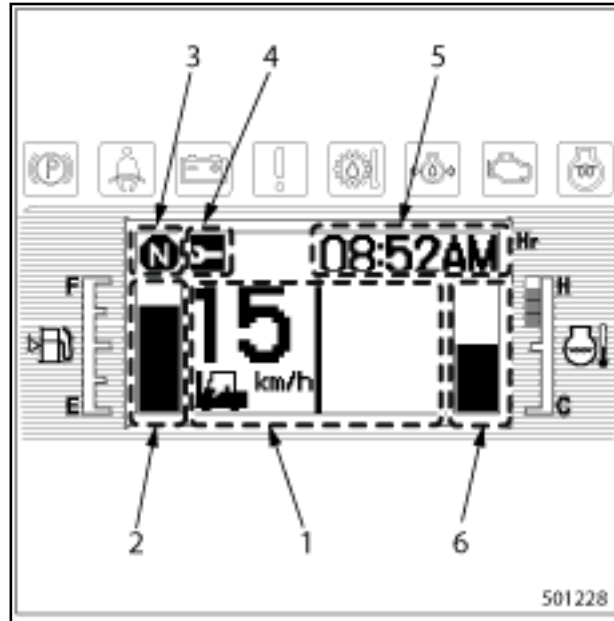


Figure 3-45.

- |                             |                              |
|-----------------------------|------------------------------|
| 1. MAIN DISPLAY             | 4. SYMBOL DISPLAY (OPTION)   |
| 2. FUEL GAUGE DISPLAY       | 5. CLOCK/HOUR METER DISPLAY  |
| 3. TRAVEL DIRECTION DISPLAY | 6. COOLANT TEMPERATURE GAUGE |

<b>Meter panel internal (ambient) temperature</b>	-
85°C (185°F) or higher	LCD display on the screen automatically hides.
105°C (221°F) or higher	Backup light goes off automatically.

Table 3-21.

- NOTE:**
- The LCD backup light illuminates the fuel mark (left side) and coolant temperature mark (right side) on the LCD screen.
  - For safety, warning icons will not go off automatically.
  - When the temperature is extremely low (0°C (32°F) or below), the response of the LCD display becomes slower.

### 3.5.2 BASIC DISPLAY

#### Screen display with key switch in ON position

When the key switch is turned to the ON position, the LCD screen displays in the order of the brand logo screen, the password authentication screen, and the normal display screen. Also, truck history is displayed by the operation of button.

#### Brand logo screen

When the key switch is turned to the ON position, the brand logo screen is displayed for 2 seconds while light check is being executed.

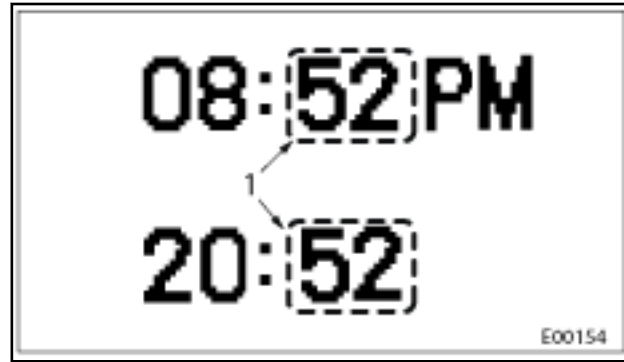


Figure 3-57.

1. DIGITS TO BE ADJUSTED IS BLINKING

Button	Press	Display
△	Short	00 to 59 (1 min. at each press)
	Long	00 to 59 (continuous)
▽	Short	59 to 00 (1 min. at each press)
	Long	59 to 00 (continuous)
○	Short	Move to the standard screen

Table 3-30.

### How to display hour meter

Turn the key switch to the ON position. Screen display selection is available while the engine is running.

With a short press of the ○ button, the display changes in the order of hour meter, clock time, and remaining fuel amount.

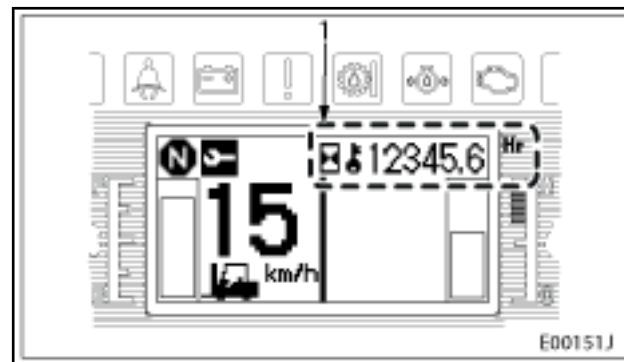
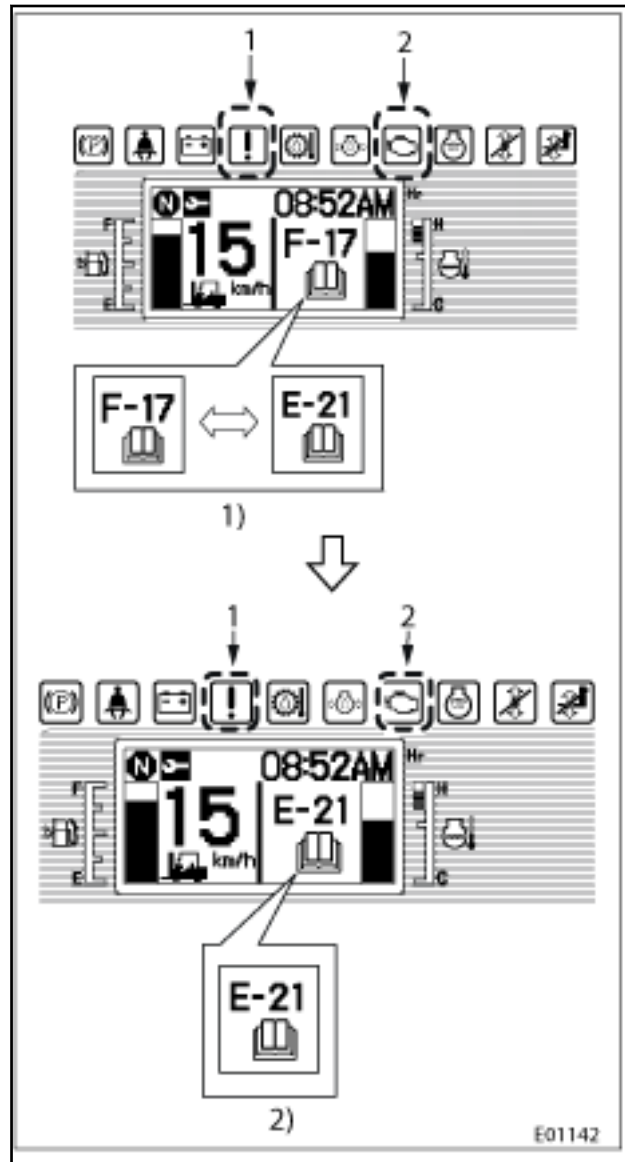


Figure 3-58.

1. HOUR METER

**NOTE:** Fuel consumption display is only available for D04EG diesel engine models and K21/25E gasoline engine models.



**Figure 3-69.**

- |    |                                                |    |                                                                       |
|----|------------------------------------------------|----|-----------------------------------------------------------------------|
| 1. | MULTI-PURPOSE WARNING ICON GLOWS               | 2. | ENGINE CHECK INDICATOR ICON GLOWS                                     |
| 1) | THE DIAGNOSTIC CODES ARE DISPLAYED ALTERNATELY | 2) | THE DIAGNOSTIC CODE WITH BLACK CHARACTERS ON A WHITE BACKGROUND GLOWS |

The illustration shows the truck history screen when there is no self diagnosis history.

### 3.5.6 WARNING SYMBOL

The following diagnostic symbols are displayed in the main area.

- NOTE:**
- When the overspeed limit function is used, set the travel speed value within the speed limit.
  - The trigger speed value for exterior alarm function is different from the speed value for the overspeed warning display.
  - Trigger speed value setup on the screen B is also available.
  - Different trigger speed value setup on screen A and B is also available.
  - Different trigger load value setup on screen A and B is also available.

**Load value setting (load value is set in screen B)**

- (1) With a short press on  $\Delta$  or  $\nabla$  button, select the load value symbol to bring up the load value setting screen on screen B. Enter with a short press on  $\bigcirc$  button.

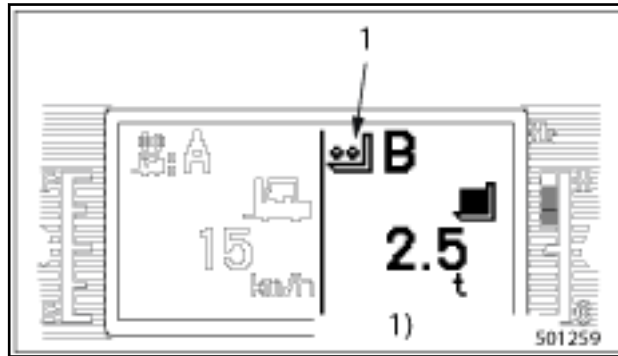


Figure 3-80.

1. LOAD SETTING SYMBOL

1) SCREEN B

Button	Press	Display
$\Delta$ or $\nabla$	Short press	
$\bigcirc$	Short press	Enter (execution)

Table 3-43.

- (2) With a short press on  $\Delta$  or  $\nabla$  button, select "load value" and enter it with  $\bigcirc$  button.

Button	Press	Display
$\Delta$	Short press	0`50 (0.1 at a time)
	Long press	0`50 (Incrementally)
$\nabla$	Short press	50 to 0 (0.1 at a time)
	Long press	50 to 0 (Incrementally)
$\bigcirc$	Short press	Enter (execution)

Table 3-44.

Condition		Possible cause	Action
	Sound quality is bad	Horn is faulty	Replace
		Horn switch is faulty	Replace
		Horn is faulty	Replace

Table 3-52. (Continued)

### 3.7.5 BATTERY RELATED PROBLEM

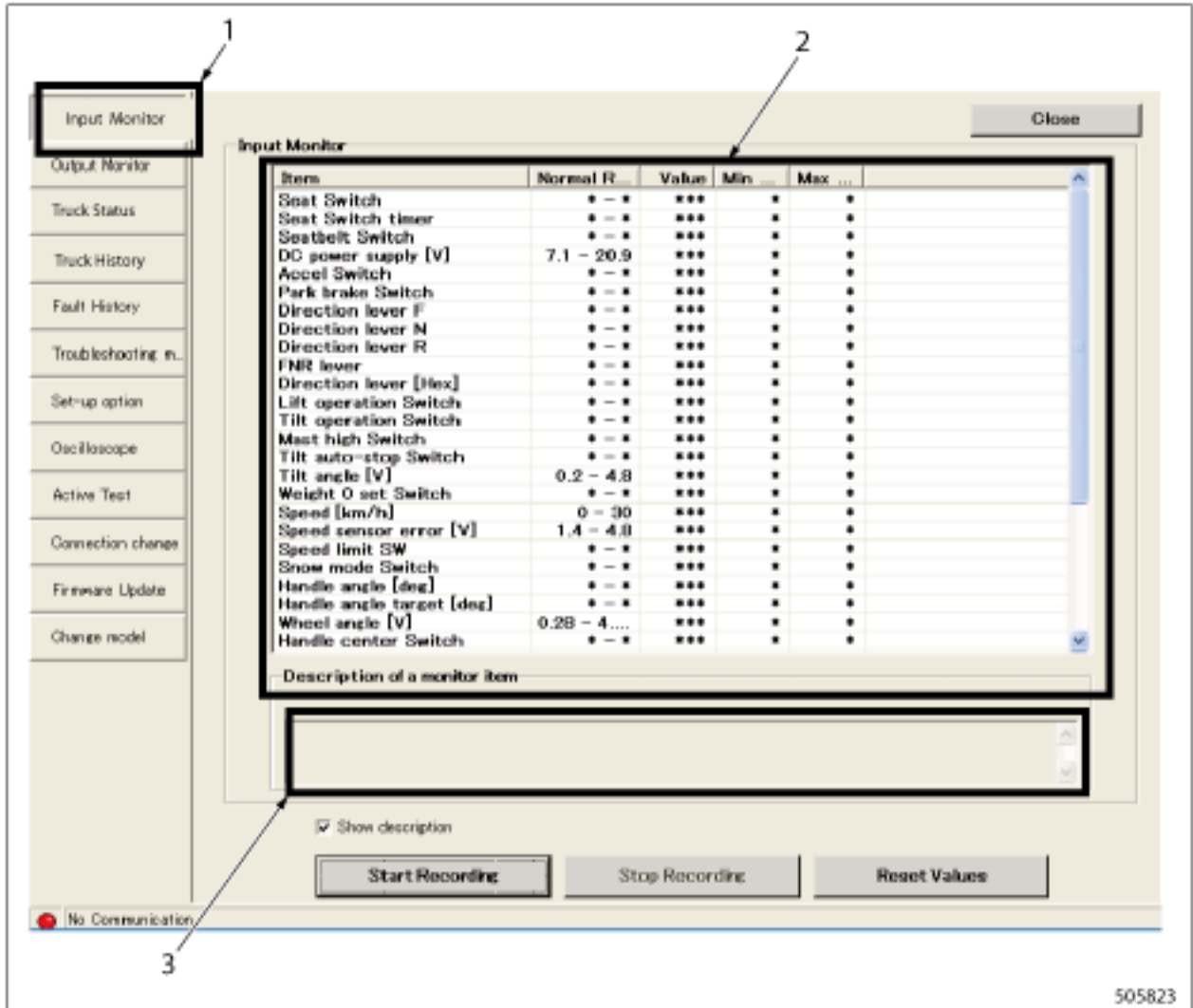
Condition		Possible cause	Action	
Battery	Weak battery	Alternator belt slips	Adjust tension	
		Alternator	Stator coil open circuit	Repair or replace
			Rotor coil open circuit	Replace
			Poorly-seated brushes on slip rings	Replace brushes if worn-out, (clean the folder) and polish slip rings
			Diode short or open circuit	Replace
		Regulator	Low output voltage	Adjustment
		Battery	Electrolyte level low or inappropriate quality	Refill or adjust the S.G.
			Defective cell plates (internal short-circuit)	Replace
			Poor connection of terminals	Clean and tighten
		Wiring	Open circuit or loose connection between key switch and regulator IC terminal	Repair
			Blown out fuse in the circuit above or loose connection on the holder	Replace fuse or repair the holder contact part
			Open circuit or loose connection between regulator terminal and alternator terminal	Repair

Table 3-53.

4.3.2 TOOLBOX

Input monitor

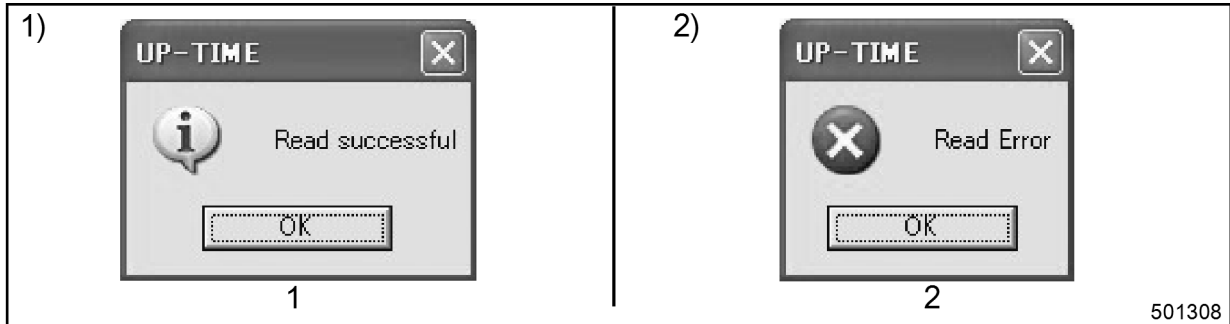
The monitor is used to check input status of sensors and switches.



- 1. INPUT MONITOR BUTTON
- 2. MONITOR WINDOW
- 3. DESCRIPTION OF A MONITOR ITEM

Item		Item	
Seat switch	ON/OFF	Lowering speed switch	ON/ OFF
Seat switch timer	ON/OFF	Lift operation switch	ON/ OFF
Seat belt switch	ON/OFF	Tilt operation switch	ON/ OFF
DC power supply	[V]	Mast high switch	ON/ OFF
Accel switch		Tilt auto-stop switch	ON/ OFF
Park brake switch		Tilt angle	[V]
Direction lever F	ON/OFF	Weight 0 set switch	ON/ OFF

- 1. SUCCESS DIALOG
- 2. ERROR DIALOG
- 1) WHEN THE READ IS SUCCESSFUL
- 2) WHEN THE READ IS UNSUCCESSFUL



- 1. SUCCESS DIALOG
- 2. ERROR DIALOG
- 1) WHEN THE READ IS SUCCESSFUL
- 2) WHEN THE READ IS UNSUCCESSFUL

**Set-up option**

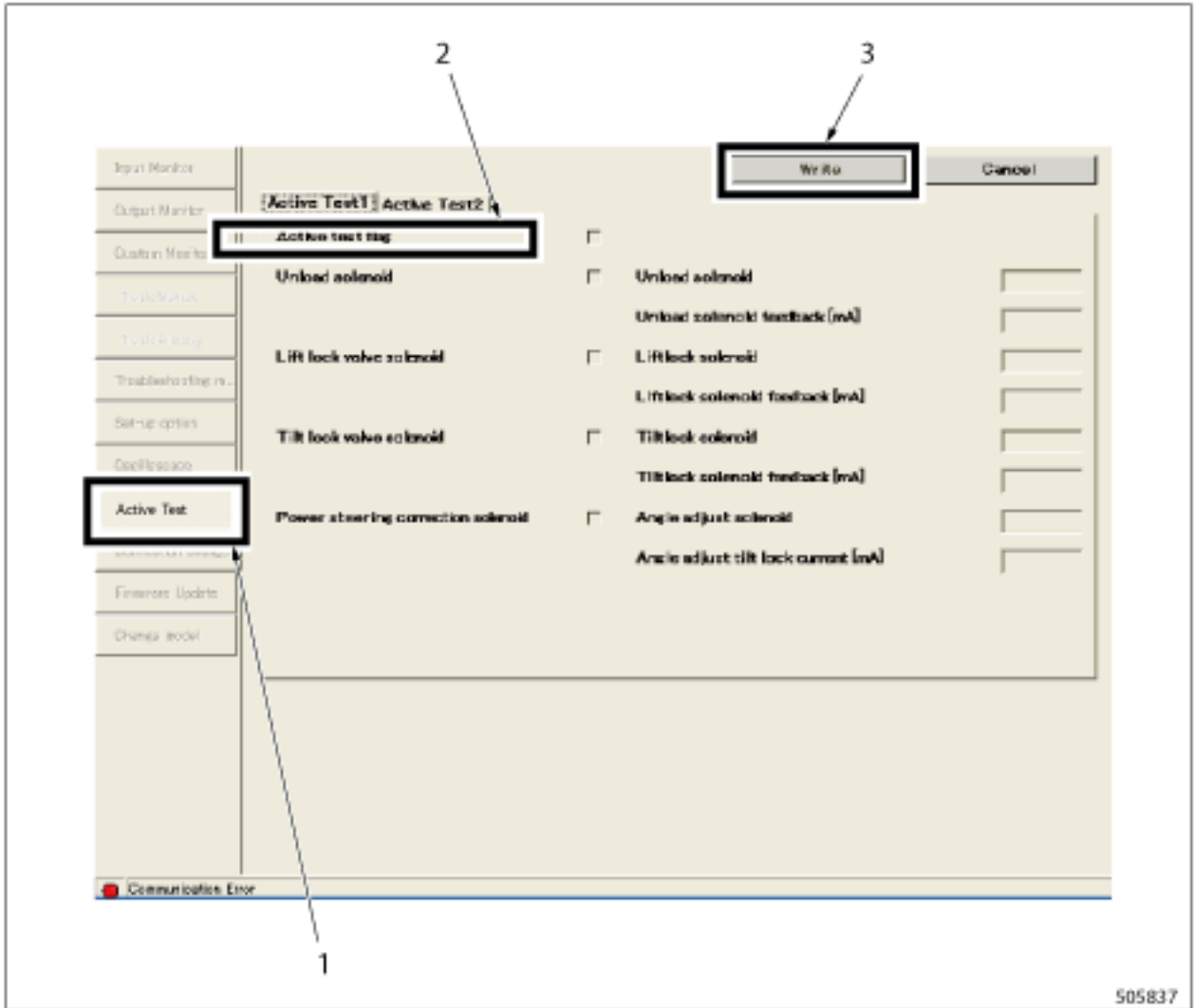
Click the Set-up option button from the menu or toolbox to display the setup option screen in the main window. In the setup option screen, you can

monitor the current setup values, or you can rewrite the setup values. Click the Write button to save your changes.

**4.4.3 ACTIVE TEST INSPECTION PROCEDURE**

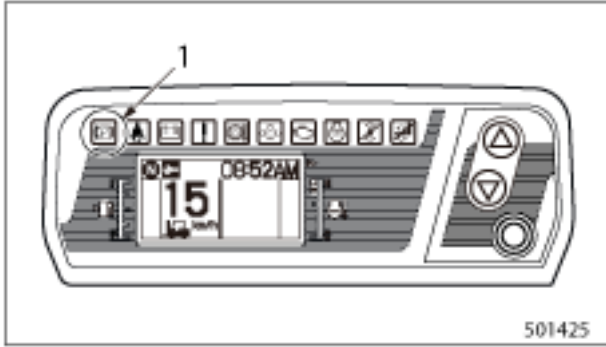
- (1) Connect the service tool and turn the key switch to the ON position. (DO NOT start the engine.)

- (2) Display the active test screen by pressing the active test button in the service tool screen.



1. ACTIVE TEST FLAG
2. ACTIVE TEST

3. WRITE BUTTON



1. TURN OFF

- (8) Apply the parking brake. Make sure that the parking brake warning icon in the meter panel glows and the warning alarm stops sounding.

**4.7.3 CHECKING THE OPERATION OF PARKING BRAKE WARNING ALARM/ICON WITH KEY IN OFF POSITION**

- (1) Lock the parking brake and keep it locked. Place the direction lever in the NEUTRAL position. Turn the key switch to the OFF position to turn the engine OFF. This turns off the power to the VCM controller and the meter panel.
- (2) Make sure that the parking brake warning alarm activates when the parking brake switch is released. (This function is not affected by the seat switch status)
- (3) Make sure that the parking brake warning alarm stops when the parking brake is shifted to the locked position.



- 1. RELEASE
- 2. LOCK

**CAUTION**

BE SURE to park the lift truck on level and hard ground before checking this function.

**If seat switch is not turned ON**

Check the seat switch operation and wiring connections by seeing "VCM (K21/25, K21/25E, and S4S engine models), Page 4-40" or "VCM (D04EG engine model), Page 4-42" and "Seat Switch, Page 4-55".

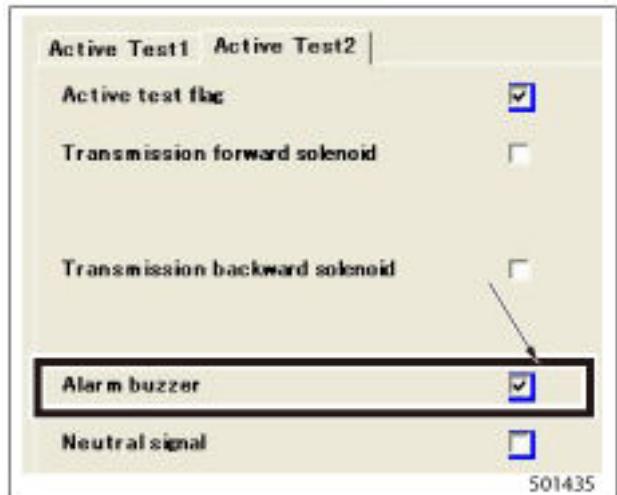
**If parking brake switch is not turned ON**

Check the parking switch operation and wiring connections by seeing "VCM (K21/25, K21/25E, and S4S engine models), Page 4-40" or "VCM (D04EG engine model), Page 4-42" and "Seat Switch, Page 4-55".

**If warning alarm is not turned ON**

If the warning alarm is not turned ON, check the warning alarm output by seeing "Active Test Inspection Procedure, Page 4-34".

If the warning alarm does not activate even after the active test inspection, check the wiring connections by seeing "VCM (K21/25, K21/25E, and S4S engine models), Page 4-40" or "VCM (D04EG engine model), Page 4-42", "Warning Alarm, Page 4-60", "Warning Alarm Relay, Page 4-61", and "Warning Buzzer Circuit, Page 4-62".

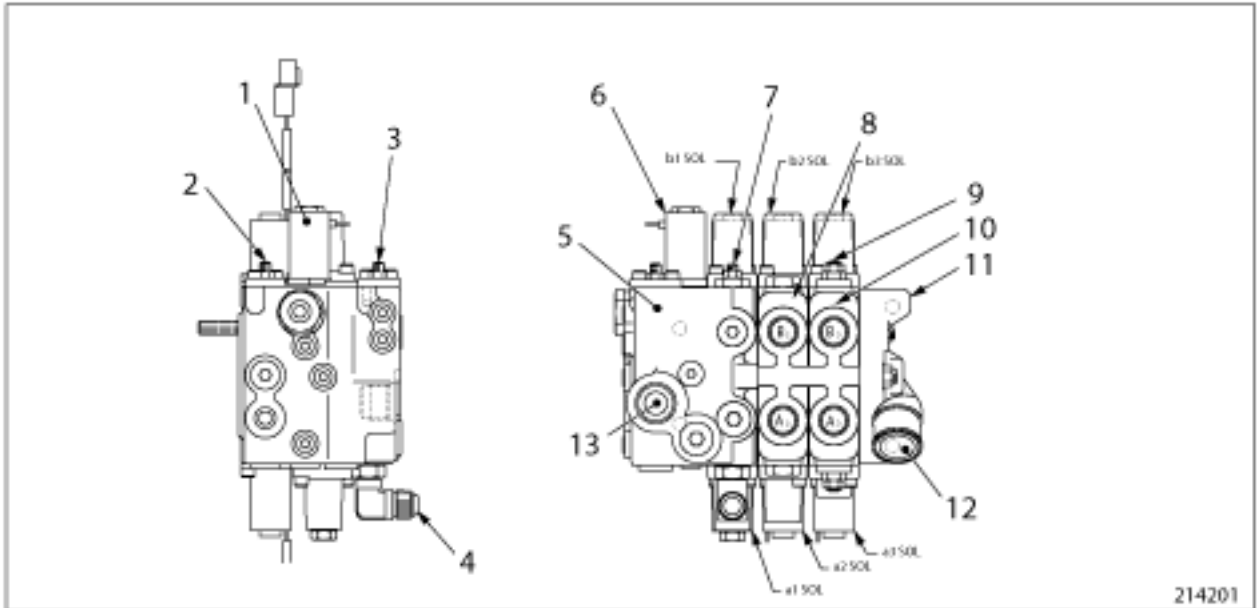


Pin No.	Circuit No.	Signal name
17	Blank	Diagnostic Mode Switch 1
18	-	-
19	-	-
20	-	-
21	-	-
22	-	-
23	-	-
24	-	-
25	-	-
26	-	-
27	-	-
28	-	-
29	-	-
30	-	-
31	-	-
32	-	-
33	-	-
34	-	-
35	-	-
36	-	-
37	-	-
38	-	-
39	-	-
40	-	-
41	-	-
42	-	-
43	-	-
44	537 (G)	Throttle 15V Supply
45	166 (WL)	Throttle 25V Supply
46	-	-
47	-	-
48	-	-
49	-	-
50	588 (G/Y)	Glow Relay Signal
51	-	-
52	-	-
53	589 (L/R)	CAN 2L

1. UNLOADING SOLENOID CONNECTOR


2. LIFT LOCK SOLENOID CONNECTOR

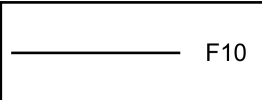
**FC valve unit**

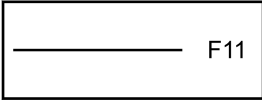


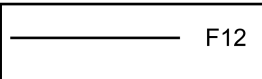
- 1. UNLOAD VALVE SOLENOID
- 2. PF RELIEF
- 3. MAIN RELIEF
- 4. TO LIFT CYLINDER
- 5. INLET VALVE ASSEMBLY
- 6. UNLOAD VALVE SOLENOID
- 7. EMERGENCY SHUT-OFF VALVE (LIFT LOCK)

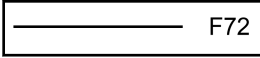
- 8. TILT VALVE ASSEMBLY
- 9. EMERGENCY SHUT-OFF VALVE (ATTACHMENT)
- 10. ATTACHMENT VALVE ASSEMBLY
- 11. END COVER ASSEMBLY
- 12. TO HYDRAULIC TANK (OIL RETURN PORT)
- 13. FROM HYDRAULIC TANK (OIL INTAKE PORT)

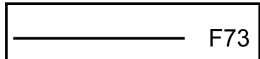
Diagnosis	TMS communication warning (F08)
Logic conditions	No CAN received from TMS. (2-second continuity) <div style="text-align: right; border: 1px solid black; padding: 2px; display: inline-block;">  </div>
Recovery	Auto recovery
Action	Activates with default values of TMS incoming data.
LED blink pattern	B

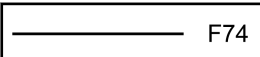
Diagnosis	Lift Lever Neutral Warning (F10)
Logic conditions	Lift lever open angle is 20% or more. (when key switch is ON) <div style="text-align: right; border: 1px solid black; padding: 2px; display: inline-block;">  </div>
Recovery	Auto recovery when the lever is placed in NEUTRAL.
Action	<ul style="list-style-type: none"> <li>· Turn OFF all solenoid outputs of operating functions.</li> <li>· Turn OFF the unload solenoid.</li> </ul>
LED blink pattern	C

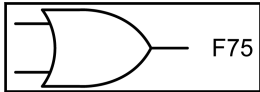
Diagnosis	Tilt Lever Neutral Warning (F11)
Logic conditions	Tilt lever open angle is 20% or more. (when key switch is ON) <div style="text-align: right; border: 1px solid black; padding: 2px; display: inline-block;">  </div>
Recovery	Auto recovery when the lever is placed in NEUTRAL.
Action	<ul style="list-style-type: none"> <li>· Turn OFF all solenoid outputs of operating functions.</li> <li>· Turn OFF the unload solenoid.</li> </ul>
LED blink pattern	C

Diagnosis	Attachment 1 Lever Neutral Warning (F12)
Logic conditions	Attachment 1 lever open angle is 20% or more. (when key switch is ON) <div style="text-align: right; border: 1px solid black; padding: 2px; display: inline-block;">  </div>
Recovery	Auto recovery when the lever is placed in NEUTRAL.

Logic conditions	CAN receiving of abnormal flag from output unit. 
Recovery	Turn ON power again.
Action	Set Attachment 3 current command value to 0 mA.
LED blink pattern	E

Diagnosis	Hour meter GAP warning (F73)
Logic conditions	Hour meter difference between meter panel and VCM is ± 24 hours or more. 
Recovery	Update #252 M/P hour meter with service tool.
Action	VCM sends zero to hour meter. · VCM hour meter is not overwritten.
LED blink pattern	E

Diagnosis	Attachment 3 Solenoid Leak (F74)
Logic conditions	CAN receiving of abnormal flag from output unit. 
Recovery	Turn ON power again.
Action	Set the current command value of all operating functions to 0 mA and turn OFF unload solenoid.
LED blink pattern	E

Diagnosis	Unload Solenoid Warning (F75)
Logic conditions	· Current value is 160 mA or less (1800- millisecond continuity) · Input signal is 2.4 A or more (200-millisecond continuity) 
Recovery	Turn ON power again.
Action	Turn OFF the unload solenoid output.
LED blink pattern	E

Diagnosis	Lift lock valve warning (F77)
-----------	-------------------------------

Code	Diagnostic code name	Probable cause	Check items
		3. Wheel angle sensor faulty	3. Sensor connection check
		4. Controller faulty	
F-41	Output unit warning	1. Output unit faulty	1. Output unit check
F-44	Output unit PWM voltage warning	1. Power shortage	1. Battery voltage check
		2. Output unit faulty	2. Output unit check
		3. VCM faulty	3. VCM check
		4. Harness faulty	4. Harness connection check
F-45	Output unit communication warning	1. Output unit faulty	1. Output unit check
		2. VCM faulty	2. VCM check
		3. Harness faulty	3. Harness connection check
F-46	Input unit warning	1. Input unit faulty	1. Input unit check
F-49	Input unit communication warning	1. Input unit faulty	1. Input unit check
		2. VCM faulty	2. VCM check
		3. Harness faulty	3. Harness connection check
F-50	Lift up solenoid warning	1. Connector contact faulty	1. Connector connection check
		2. Diode faulty	2. Diode connection check
		3. Harness faulty	3. Harness connection check
		4. Lift up solenoid faulty	4. Lift up solenoid connection check
		5. Controller faulty	
F-52	Lift down solenoid warning	1. Connector contact faulty	1. Connector connection check
		2. Diode faulty	2. Diode connection check
		3. Harness faulty	3. Harness connection check
		4. Lift up solenoid faulty	4. Lift up solenoid connection check
		5. Controller faulty	
F-54	Lift solenoid leak	1. Connector contact faulty	1. Connector connection check
		2. Diode faulty	2. Diode connection check

Code	Diagnostic code name	Probable cause	Check items
		5. When throttle min position learning abnormally small.	
		6. When throttle valve closed position learning is impossible.	
		7. When there is an warning on correlation between throttle sensors 1 and 2.	
E-24	Accelerator sensor warning	1. When accelerator sensor 1 output voltage of 0.15V or less (break) continues for a length of time.	
		2. When accelerator sensor 1 output voltage of 5V or (short) continues for a length of time.	
		3. When accelerator sensor 2 output voltage of 0.15V or less (break) continues for a length of time.	
		4. When accelerator sensor 2 output voltage of 5V or more (short) continues for a length of time.	
		5. When there is an warning on correlation between accelerator sensor 1 and 2.	
E-25	O <sup>2</sup> sensor warning	1. When O <sup>2</sup> sensor output voltage is higher than the normal voltage (1.4V or more)	
		2. When break of O <sup>2</sup> sensor signal line occurs.	
E-26	O <sup>2</sup> sensor heater warning	1. When O <sup>2</sup> sensor heater control voltage of 1.2V or less (break or short) continues for a length of time.	

**REMOVAL SEQUENCE**

- |                                                    |                                                                              |
|----------------------------------------------------|------------------------------------------------------------------------------|
| 1. RESERVE TANK                                    | 7. COOLER HOSE (BETWEEN RADIATOR AND POWERSHIFT TRANSMISSION)                |
| 2. HOSE (UPPER)                                    | 8. COOLING FAN                                                               |
| 3. HOSE (LOWER)                                    | 9. FAN BELT                                                                  |
| 4. HOSE (BETWEEN HYDRAULIC TANK AND CONTROL VALVE) | 10. FAN GUARD ASSEMBLY                                                       |
| 5. HOSE (BETWEEN HYDRAULIC TANK AND OIL PUMP)      | 11. UNIVERSAL JOINT (BETWEEN TRANSMISSION AND REDUCTION/ DIFFERENTIAL GEARS) |
| 6. HOSE (OIL PUMP TO STEERING CONTROL VALVE)       |                                                                              |

**Preparation by**

1. Drain the coolant from the radiator by loosening the drain cock at the bottom of the radiator.
2. Drain the coolant from the engine by removing the drain plug. (Note that the position of the drain plug differs by engine type).

**Suggestions for Removal**

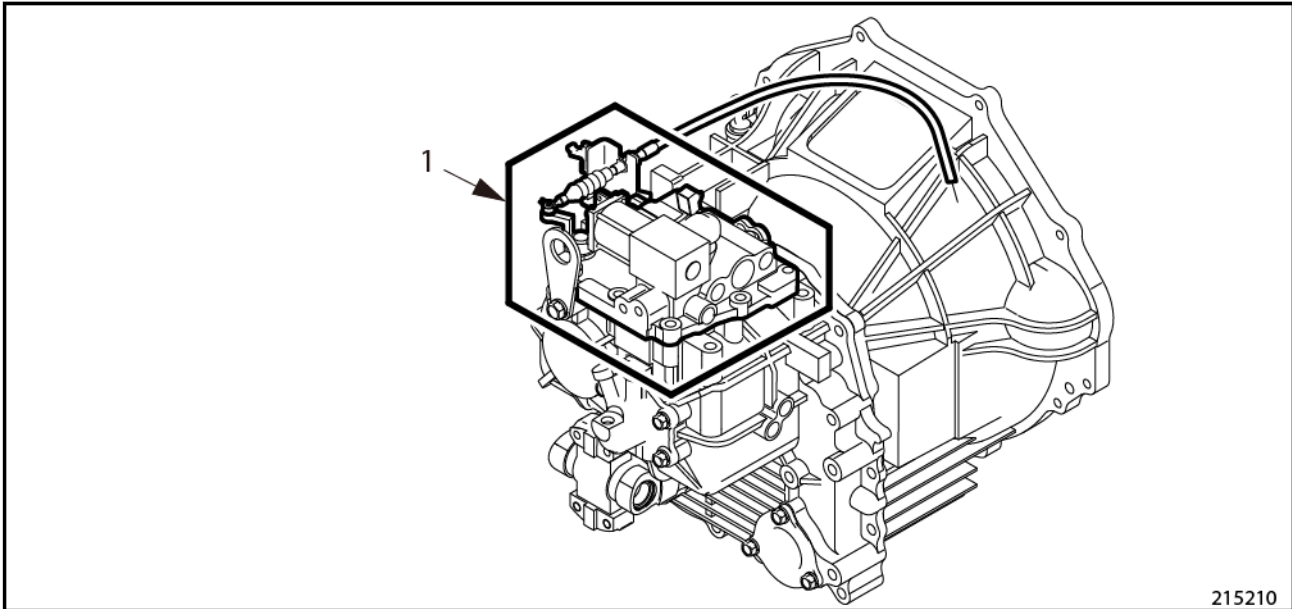
Disconnect the cooler hose 7 from the transmission side and temporarily attach it on the right side of the frame.

**Installation**

To install, follow the removal sequence in reverse.



6.3.2 OVERALL VIEW OF CONTROL VALVE



215210

- 1. CONTROL VALVE

6.4 POWERSHIFT TRANSMISSION, DISASSEMBLY

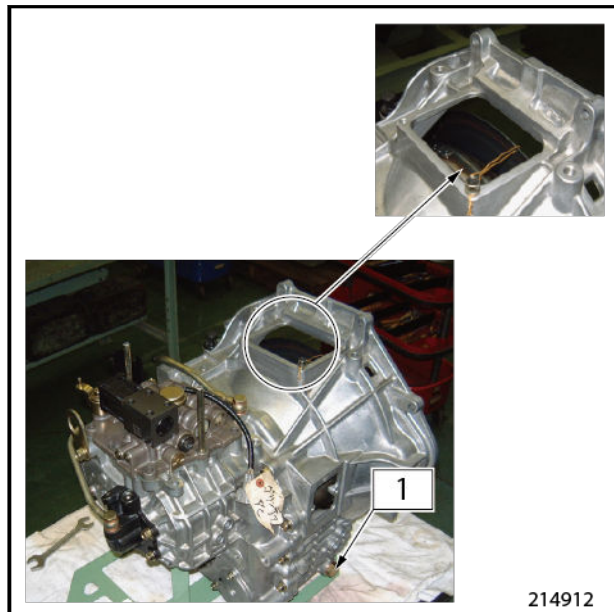
6.4.1 PREPARATION

6.4.1.1 DRAINING TRANSMISSION OIL

- (1) Before removing the transmission from the lift truck, attach a wire on the torque converter assembly to prevent it from slipping out.
- (2) Remove the oil drain plug and drain transmission oil.

Transmission oil capacity	8 (2.11)
---------------------------	----------

Units: L (US gal.)



214912

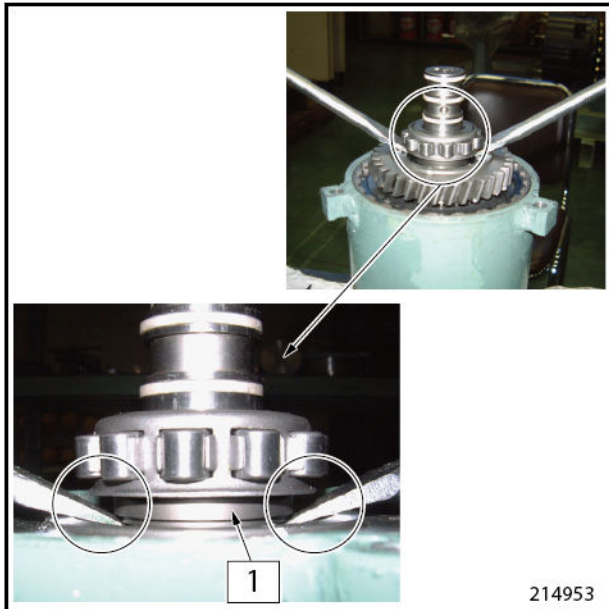
- 1. OIL DRAIN PLUG

6.4.1.2 TRANSMISSION, SETTING ON THE STAND

Place the transmission on the stand.

- (2) Using a screw driver, raise bearing together with input spacer.

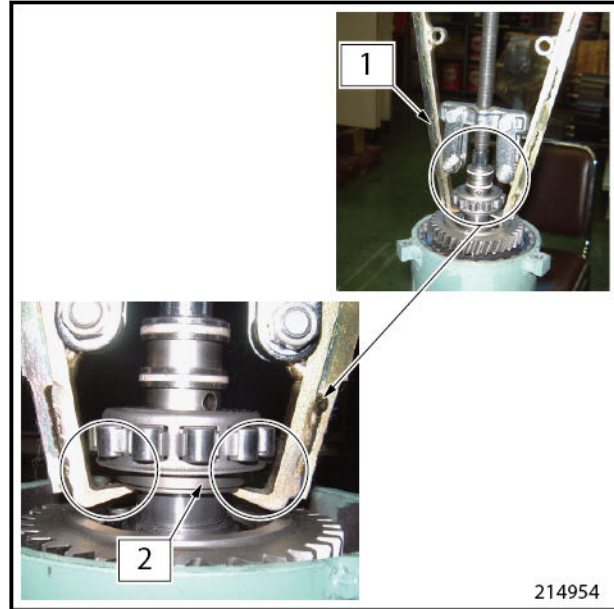
**NOTE:** When using a screw driver, be sure to insert the screw driver beneath the input spacer to raise bearing. Otherwise, the bearing case will be damaged.



- 1. INPUT SPACER

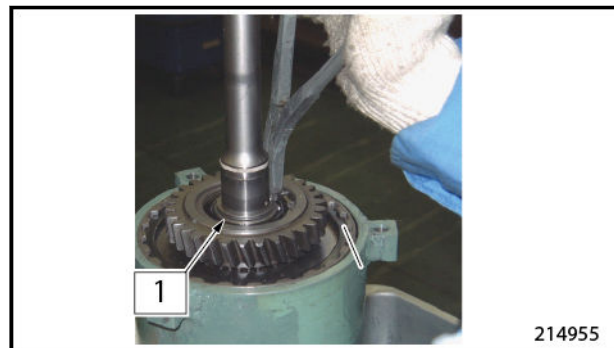
- (3) Using the puller (91A68-01800), remove bearing together with input spacer.

Part name	Part number
Puller	91A68-01800



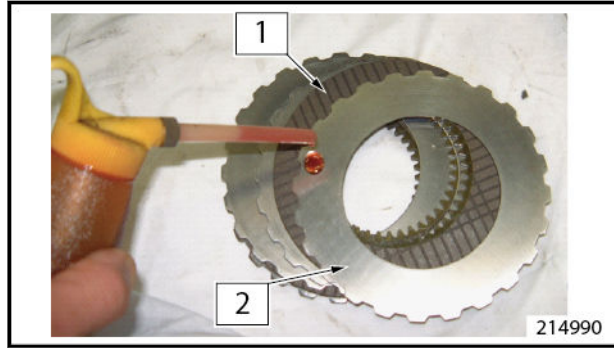
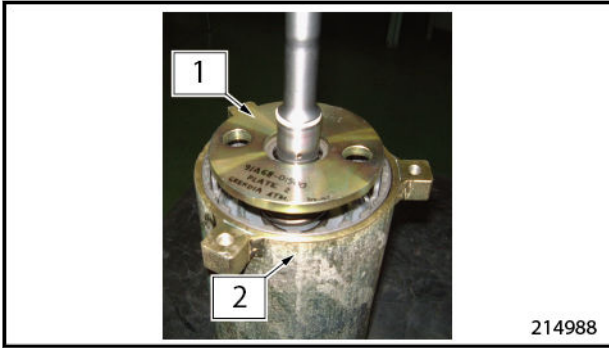
- 1. SPECIAL TOOL (PULLER,91A68-01800)
- 2. INPUT SPACER

- (4) Remove snapping.



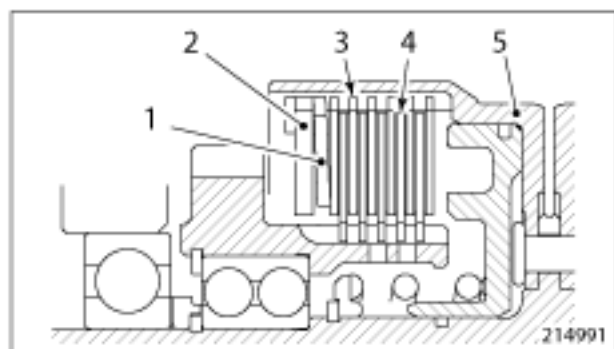
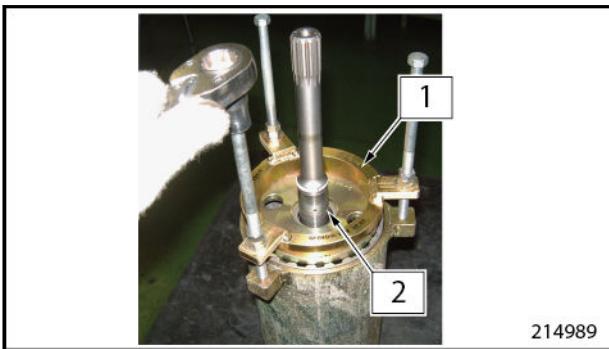
- 1. SNAPRING

- (5) Using a screw driver, raise forward gear assembly.



1. SPECIAL TOOL (PLATE 2, 91A68-01500)
2. SPECIAL TOOL (STAND, 91A68-01300)

1. FRICTION PLATE
2. MATING PLATE



1. SPECIAL TOOL (PLATE 1, 91A68-01400)
2. SNAPRING

1. BELLEVILLE SPRING
2. PRESSURE PLATE (1 PIECE)
3. MATING PLATE (6 PIECES)
4. FRICTION PLATE (5 PIECES)
5. DRUM

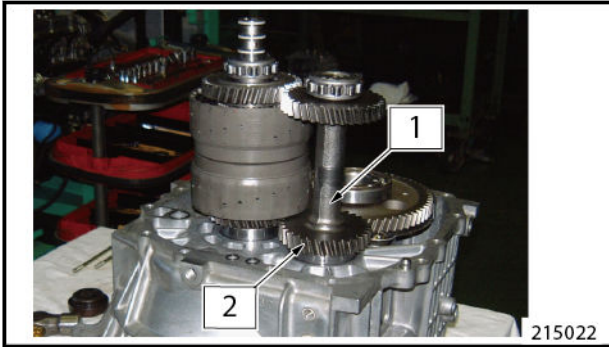
**6.5.6.2 FORWARD SIDE FRICTION PLATES AND MATING PLATES, ASSEMBLY**

- (1) Install friction plates and mating plates in the order they were removed.
- (2) Install Belleville spring and pressure plate.

- (3) Install the snapping.

- NOTE:**
- Make sure to install Belleville spring so that its inner side comes into contact with mating plate. See the below figure.
  - Apply ATF on each friction plate and mating plate before installing them on the drum.

Part name	Part number	Quantity
Snapring	58622-03001	1



1. IDLER GEAR ASSEMBLY
2. Z=30

(3) Alternately tap the input shaft gear assembly and the idler gear assembly through the plastic hammer to install. When input shaft gear assembly and idler gear assembly are seated in place, rotate the input shaft gear assembly and make sure that gears are correctly meshed.

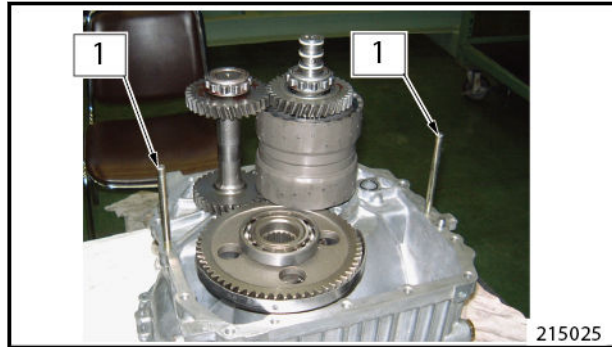


1. PLASTIC HAMMER

(4) Apply oil on each bearing thoroughly.

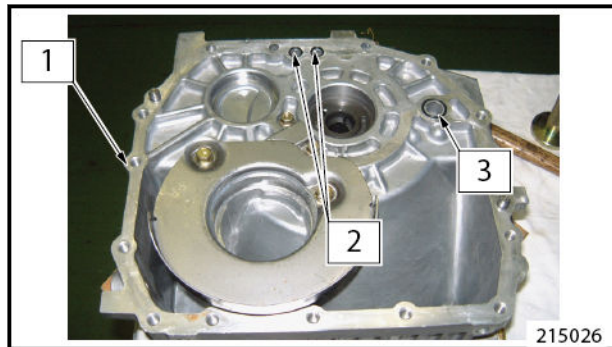


(5) Install guide bolts.



1. GUIDE BOLT

(6) Install oil seal, O-rings and transmission gasket.



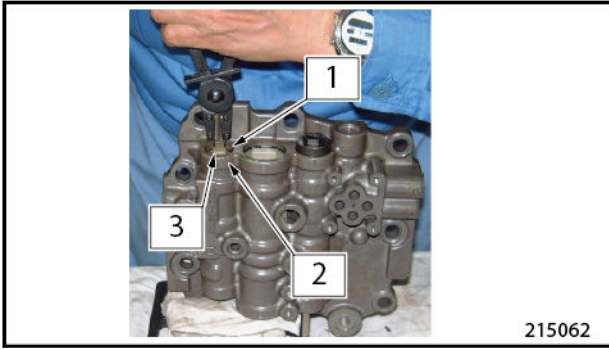
1. TRANSMISSION GASKET
2. O-RING
3. OIL SEAL

### 6.5.10 TRANSMISSION HOUSING, INSTALLATION

(1) Align the dowel holes of transmission housing with the dowels of torque converter housing.

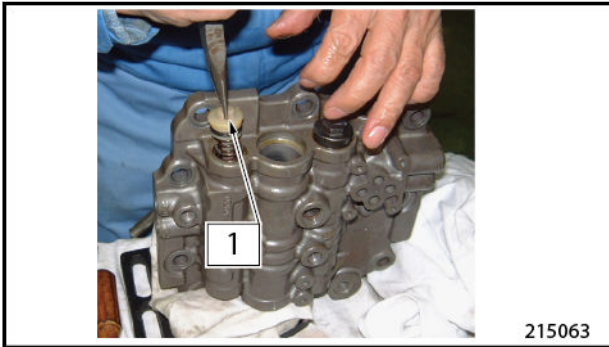
(2) Tentatively install transmission housing.

**NOTE:** When installing the transmission housing, make sure that the bearing of idler gear assembly is correctly fitted in the outer race by checking it from the control valve attaching portion.



1. SNAPRING
2. REGULATOR VALVE SECTION
3. MAIN SPRING SEAT

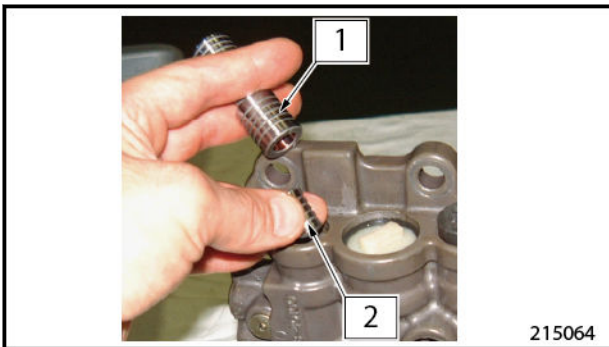
(2) Remove the main spring seat together with O-ring.



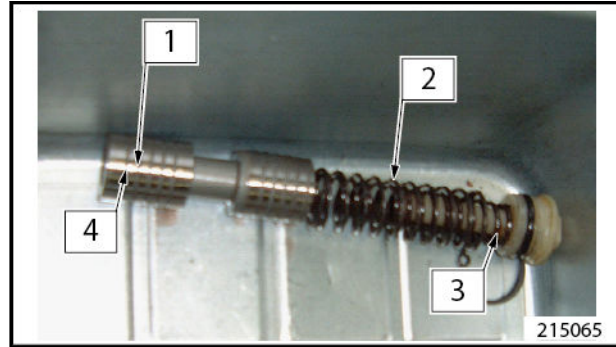
1. MAIN SPRING SEAT

### 6.6.5.2 REGULATOR VALVE, REMOVAL

- (1) Remove the inner and outer main relief springs.
- (2) Remove the regulator valve together with slug.



1. REGULATOR VALVE
2. SLUG



1. REGULATOR VALVE
2. MAIN RELIEF SPRING, OUTER
3. MAIN RELIEF SPRING, INNER
4. SLUG

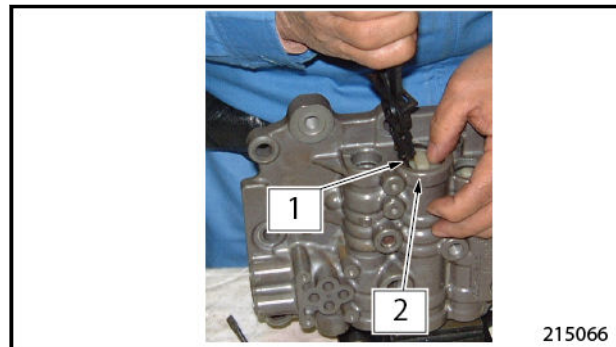
### 6.6.6 ACCUMULATOR VALVE SECTION, REMOVAL

#### 6.6.6.1 ACCUMULATOR SPRING SEAT, REMOVAL

- (1) Remove the snapping from accumulator spring seat.

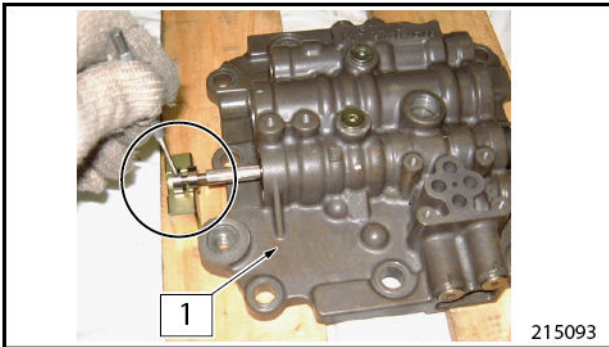
**NOTE:** When removing the snapping, slowly remove the snapping by pressing it against the accumulator spring seat. Otherwise the accumulator spring seat will pop out.

- (2) Remove the accumulator spring seat together with O-ring.

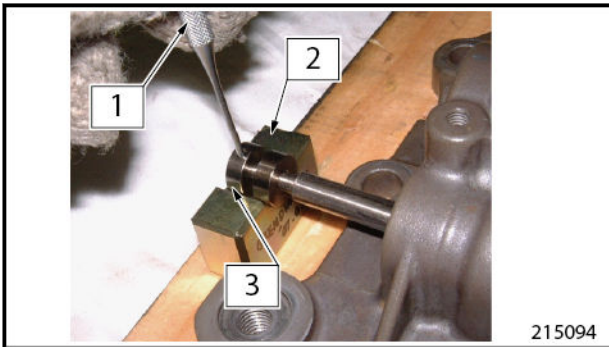


1. SNAPRING
2. ACCUMULATOR VALVE SECTION

- (3) Place the stand (91A68-02701) under the outer inching rod plate, and install springpin.

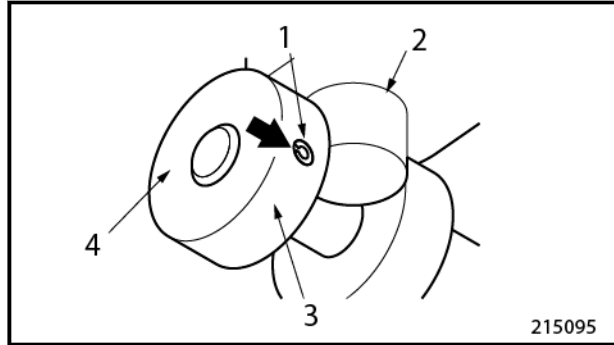


1. VALVE BODY



1. PIN REMOVER  
 2. SPECIAL TOOL (STAND, 91A68-02701)  
 3. INCHING ROD PLATE

- NOTE:**
- 1) When installing the springpin, BE SURE to use the special tool. If not, it can result in damage to the inching rod and valve body.
  - 2) When installing the springpin, orient it so that its notch faces to the end of inching rod.



1. SPRING PIN  
 2. INCHING LEVER  
 3. INCHING ROD PLATE  
 4. THE END OF INCHING ROD

**6.7.7 STRAINER, INSTALLATION**

- (1) Hold the control valve body in a vise so that inching rod protrusion side faces downward.

**NOTE:** When holding in a vise, use aluminum plates to prevent direct contact.

- (2) Install the O-ring to strainer, and apply a thin coat of grease on the O-ring.

**NOTE:** If strainer is clogging, DO NOT reuse the strainer. Replace with new one.

Part name	Part number	Quantity
O-ring	05500-24014	1
Strainer	91A28-02500	1

- (3) Install the strainer to control valve body, and tighten it to the specified torque.

Strainer	22.1 ± 2.4 (2.25 ± 0.24) [16.3 ± 1.77]
----------	----------------------------------------------

Unit: N·m (kgf·m) [lbf·ft]

6.9 TROUBLESHOOTING

6.9.1 POWERSHIFT TRANSMISSION

Not enough output power	Engine	Engine lacks power	Tune up engine
		Poor performance of engine	Tune up engine
	Torque converter	Oil level too low	Refill
		Air being sucked in	Tighten or replace O-ring
		Faulty action of spool in main regulator valve	Repair or replace
		Settling of spring in main regulator valve	Replace the spring
		Worn gears in oil pump, resulting in reduced capacity	Disassemble and inspect and if defect is found, replace the defective parts
		Magnet strainer clogged	Replace
		Worn seal rings or O-rings	Inspect, and if defective, replace
		Seizure of stator freewheel	Replace torque converter assembly
		Damage or rubbing of impeller	Replace torque converter assembly
		Transmission	Air being sucked on suction side
	Outlet pressure too low to suppress internal foaming		Adjust pressure
	Water in oil		Replace oil
	Oil level too low		Fill
	Pedal linkage misadjusted (brake shift and forward reverse)		Adjust
	Main oil pressure too low, resulting in slipping clutches		Adjust
	Worn seal rings or O-rings		Inspect, and if defective, replace
	Damaged clutch piston		Replace
	Friction plate seized or dragging		Replace
Road wheels	High mechanical resistance in road wheels	Check and adjust brake system	
No power flow	Torque converter	Flexible plate broken	Replace
		Oil level too low	Refill
		Oil pump drive defective	Replace

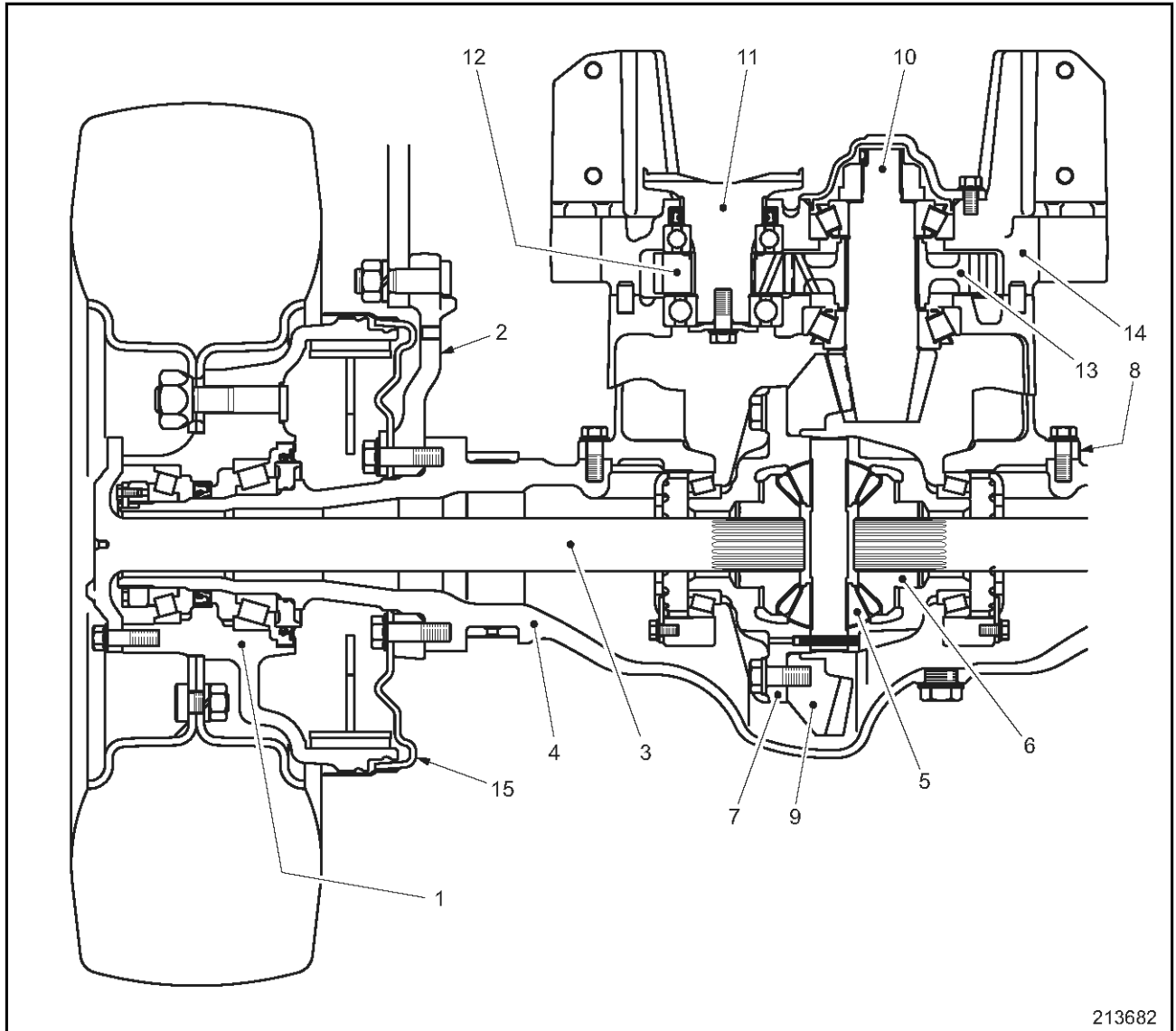


Figure 7-2.

- |                         |                      |
|-------------------------|----------------------|
| 1. FRONT WHEEL HUB      | 9. REDUCTION GEAR    |
| 2. FRAME SUPPORT        | 10. REDUCTION PINION |
| 3. AXLE SHAFT           | 11. INPUT FLANGE     |
| 4. AXLE HOUSING         | 12. DRIVE GEAR       |
| 5. DIFFERENTIAL PINION  | 13. DRIVEN GEAR      |
| 6. DIFFERENTIAL GEAR    | 14. CARRIER COVER    |
| 7. DIFFERENTIAL CASE    | 15. BACKING PLATE    |
| 8. DIFFERENTIAL CARRIER |                      |

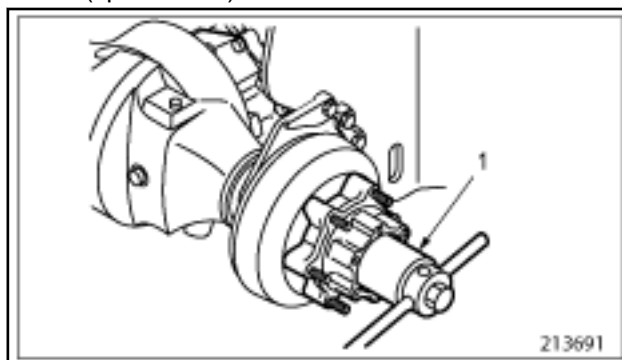
Frame support is bolted to the front axle housing together with the backing plate of the wheel brake. While front wheel hub carries a single wheel, a double wheel can be mounted to it with an optional rim.

3. Support the front end of the lift truck with jack stands at both sides to keep the lift truck in the horizontal position.
4. Remove the front wheels.

**NOTE:** It is unnecessary to remove the axle housing when removing the axle shaft or disassembling the wheel hub. Draining the oil from the axle housing is unnecessary.

**Suggestions for Disassembly**

1. Use the locknut wrench (special tool) to loosen the locknut.



**Figure 7-11.**

1. LOCKNUT WRENCH

Special tool needed	
1 ton class	91A67-00300
2 ton and 3 ton classes	03703-59001

**Table 7-4.**

2. Removing front wheel hub  
Use the wheel hub puller (special tool).

Special tool needed	
1 ton class	64309-40100 (64309-10601)
2 ton and 3 ton classes	MH061017

**Table 7-5.**

**NOTE:** It is unnecessary to remove the oil seal from the hub unless the seal is defective.

- (b) Minor flaws on the tooth surfaces can be repaired by grinding with an oil stone or sandpaper.
  - (c) If the gear and/or pinion is badly damaged, replace them as a set.
2. Differential
- (a) Check the differential case and tapered roller bearing inner race to see if the seat surface is fretted.
  - (b) Check the differential case for cracks. Check the sliding contact surfaces of thrust washer and gears for wear and damage.
  - (c) Check the teeth of the differential pinions and gears for wear, pitting, chipping and galling. Also check the area in contact with thrust washer for wear or damage.
  - (d) Check the pinions (inner surface) and pinion shafts (outer surface) for wear.
  - (e) Check the differential gears and axle shaft splines for wear and free play (looseness).

Unit: mm (in.)		
Clearance between pinions and shafts	A	0.02 to 0.085 (0.0008 to 0.0033)
	B	0.35 (0.0138)

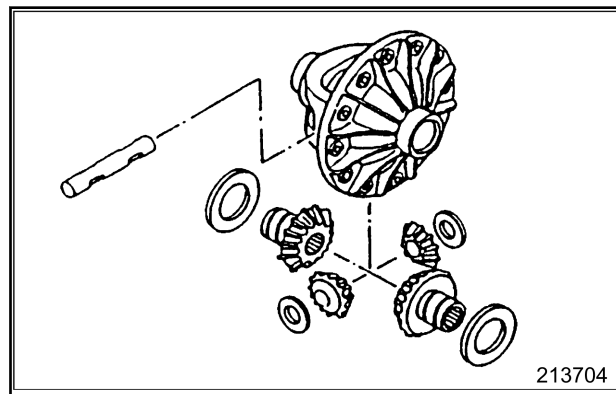
A: Standard value B: Repair or service limit

**Table 7-15.**

Unit: mm (in.)		
Free play (looseness) of differential gear and axle shaft splines	A	0.09 to 0.28 (0.0035 to 0.0110)

A: Standard value

**Table 7-16.**



**Figure 7-25.**

3. Drive gear and driven gear
- (a) Check the drive and driven gears for tooth contact, wear, pitting, galling and chipping.
  - (b) Replace both drive and driven gears as a set even if one of them is defective.

7.4 TROUBLESHOOTING

7.4.1 TROUBLESHOOTING

	Reduction bevel gear teeth badly worn, chipped	Replace
	Bearing preload too much or too little, or bearings worn excessively	Adjust or replace
	Hub bearings damaged	Replace
	Improper tooth contact between reduction bevel pinion and reduction gear	Adjust
	Reduction taper roller bearings or hub bearings damaged	Replace
	Differential gears having broken teeth, or thrust washers worn	Replace gears or w
	Foreign substance in axle housing	Clean and replace
	Loosened bolts that secure the axle shaft or differential carrier	Tighten
ner	Fit of differential gears in differential case out of specification due to wear	Replace worn parts
	Differential gear teeth broken or seized worn, or damaged by piston	Replace defective p
el	Bearing damage due to excessive preload	Replace bearings a
	Backlash between reduction bevel pinion (on output shaft) and reduction bevel gear may be too small	Adjust tooth contac

Table 7-27.

**CAUTION**

When the lift truck is lifted by either method, place jack stands under the frame to support it securely.

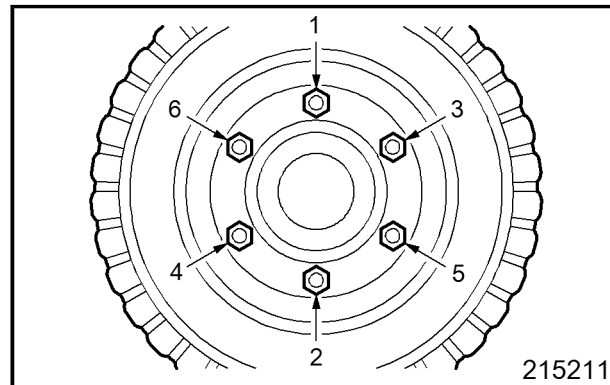
**8.2.1.2 INSTALLATION OF REAR WHEELS**

To install, follow the removal sequence in reverse.

**NOTE:** Tighten wheel nuts evenly to the specified torque.

Tightening torque	Unit: N·m (kgf·m) [lbf·ft]	
	1 ton class	2 to 3 ton class
Wheel nuts	141.2 to 172.6(14.398 to 17.6) [104.14 to 127.3]	210.1 to 256.7(21.424 to 26.176)[154.959 to 189.329]

**Table 8-3.**



**Figure 8-7.**

**8.2.1.3 REMOVAL OF AXLE ASSEMBLY**

Sequence

1. Wheel nut (6 places)
2. Rear wheel
3. Hose or pipe
4. Bolt
5. Rear axle (with cylinder)
6. Bushing support

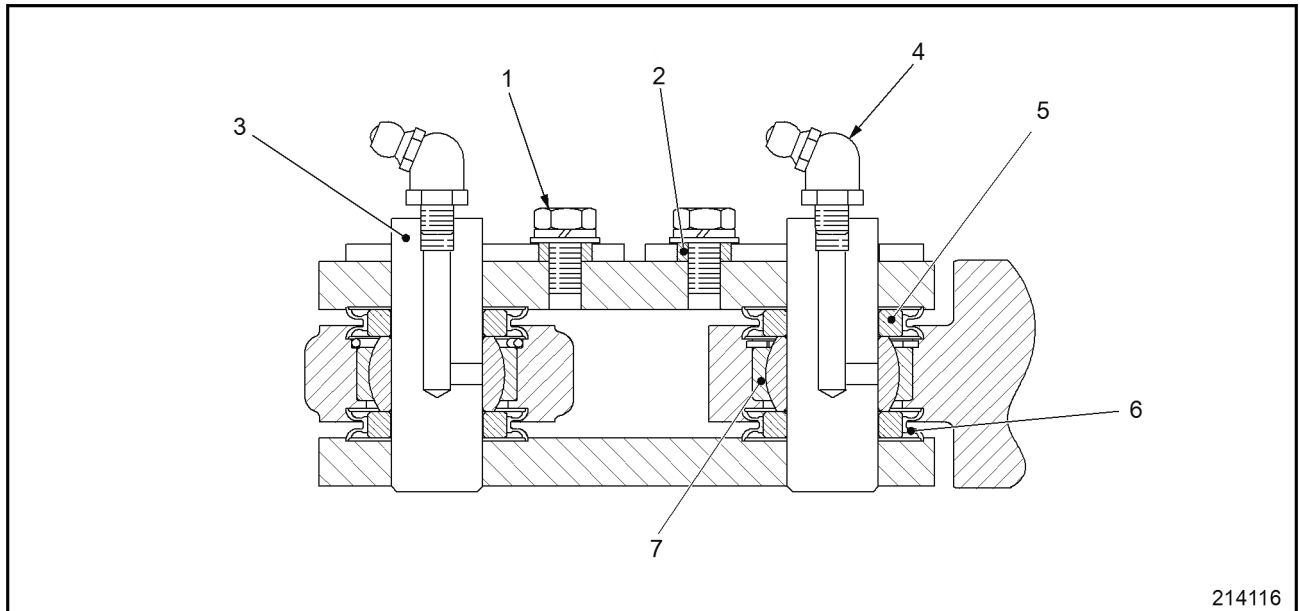
**Suggestions for Removal**

1. See the description of "8.2.1.1 REMOVAL OF REAR WHEELS" to remove the rear wheels.
2. Raise the lift truck with a jack and support the bottom of both sides of the frame with jack stands. (Approximately 500 mm (19.7 in.) is enough for the distance between the bottom of the frame and the ground.)

**Suggestions for Assembly**

To assemble, follow the disassembly sequence in reverse, paying attention to the following points.

1. Conduct the assembly work in a clean place where no dust or abrasive foreign substance enters.
2. Assemble parts while lubricating them with hydraulic oil.
3. Replace seal kit parts with new ones as much as possible.
4. Be careful not to twist O-rings when installing.

**8.3.4 TIE ROD, DISASSEMBLY AND ASSEMBLY**

**Figure 8-17.**

**SEQUENCE**

- |                             |              |
|-----------------------------|--------------|
| 1. BOLT AND WASHER ASSEMBLY | 5. RETAINER  |
| 2. SPACER                   | 6. DUST SEAL |
| 3. TIE ROD PIN              | 7. BUSHING   |
| 4. GREASE NIPPLE            |              |

**Suggestions for Disassembly**

To separate the knuckle from the tie rod, remove the bolt washer assembly 1 and spacer 2 on the knuckle side, and pull out the tie rod pin 3.

**Suggestions for Assembly**

1. Replace damaged or worn dust seal with a new one.
2. Apply a sufficient amount of grease after assembly. Apply grease enough so that it comes out of the dust seal.

**NOTE:** The parts marked by ✱ are included in the repair kit, and must be changed periodically.

**Start by**

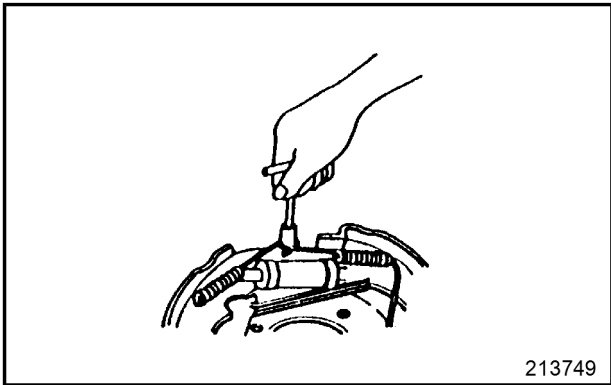
1. Remove the front wheels.
2. Remove the wheel hub and brake drum.
3. Separate the parking brake lever and cable at the bottom of wheel brake.
4. Disconnect the brake pipe from the wheel brake assembly.

**Suggestions for Disassembly**

1. Removing return springs  
Use the spring remover to remove the return springs from the shoe guide plates.

Special tool needed	
Spring remover	64309-15411

**Table 9-3.**



**Figure 9-6.**

2. Removing hold-down springs  
Use the spring retainer to remove the hold-down springs from the backing plate.

Special tool needed	
Spring retainer	64309-15412

**Table 9-4.**

### 9.3 INSPECTION AND ADJUSTMENT

#### 9.3.1 AUTOMATIC ADJUSTER TEST

1. With the clearance A between the lining and drum being set to specification, pull the cable with attached spring using a finger as shown. The lever should turn the adjusting screw wheel by one notch and, when the cable is released, return to the original position.

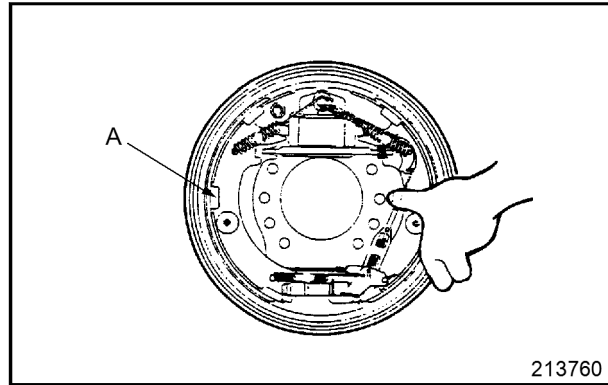


Figure 9-16.

Unit: mm (in.)		
Items	Truck type	
	1 ton class	2 ton class 3 ton class
Drum inside diameter	254 (10.0)	310 (12.2)
Drum-to-lining clearance A	0.25 to 0.5 (0.01 to 0.02)	0.1 to 0.35 (0.004 to 0.014)

Table 9-12.

2. If the lever fails, or turning the adjusting screw wheel is slow, check the position of the lever relative to the toothed wheel. The lever's actuating tip should touch the toothed wheel at approximately 7 to 9 mm (0.28 to 0.35 in.) below the center line of the screw. If the lever contact is out of range, the lever will not correctly engage with the toothed wheel, and the lever will either fail or the wheel will turn slowly.

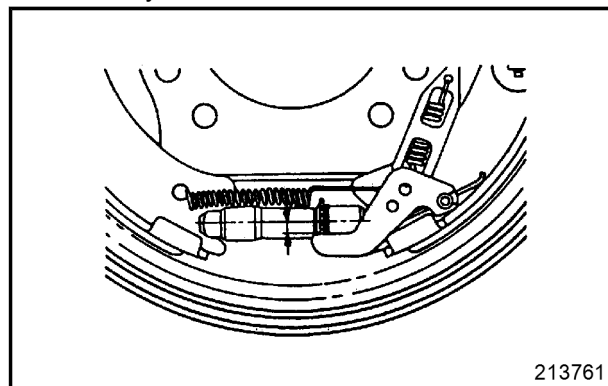


Figure 9-17.

3. If the automatic adjuster fails to operate correctly, take the following actions.:
  - (a) Ensure that the adjusting spring is correctly hooked to the primary shoe.

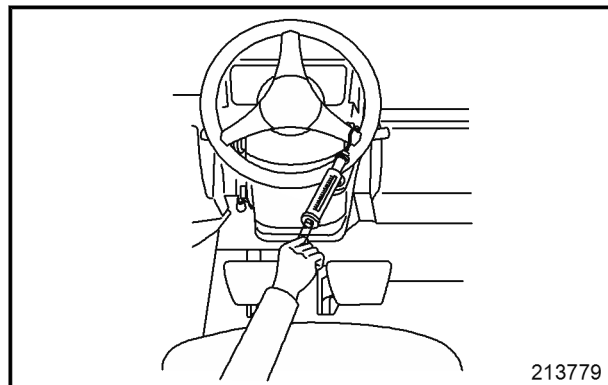
					Unit: mm (in.)		
Item			Truck type				
			1 ton class		2 to 3 ton classes		
213769							
Wheel Brake	Inside diameter of brake drum 1		A	254.0 (10.00)	310 (12.20)		
			B	256 (10.08)	312 (12.28)		
	Thickness of lining 2		A	4.87 (0.19)	5.7 (0.224)		
			B	1 (0.039)	1 (0.039)		
	Clearance between drum and lining 3 (Total)		A	0.5 to 1.0 (0.02 to 0.04)	0.2 to 0.7 (0.008 to 0.02)		
	Return spring 4	Free length		A	102 (4.02)	Primary: 120 (4.72) Secondary: 139.3 (5.48)	
		Set force/ Length under set force	N (kgf) [lbf]	A	157±16/111 (16±1.6/111) [3.5±3.6/0.36 ]	Primary: 226±23/134 (23±2.3/134) [51±5.2/0.44] Secondary: 226±23/145.4 (23±2.4/145.4) [51±5.2/0.48]	
	Adjusting spring 5	Free length		A	98.4 (3.87)	126 (4.96)	
		Set force/ Length under set force	N (kgf) [lbf]	A	58.8±5.9/126 (6±0.6/126) [13±1.3/0.41]	78±8/145.4 (8±0.8/145.4) [17.5±1.8/0.48]	

Table 9-17. (Continued)

**Inspection after Installation****Steering effort**

1. Pull the hand brake lever.
2. Run the engine to warm the hydraulic oil temperature up to between 40 and 60 °C (104 and 140 °F).
3. Attach a spring scale on the rim (or a spoke) of the steering wheel, and measure the steering effort required to turn the steering wheel clockwise or counterclockwise from the straight-ahead position. Steering effort should be the value specified below or lower.

Unit: N (kgf) [lbf]	
Steering effort (at steering wheel rim)	13 (1.3) [2.92]

**Table 10-2.****Figure 10-7.****10.2.4 STEERING VALVE****10.2.4.1 REMOVAL**

1. Remove the cover 4 around the steering column.
2. Disconnect four hoses from the steering valve.
3. Remove the bolt 5 and then, remove the steering valve 6.

**10.2.4.2 INSTALLATION**

To install the steering valve, follow the removal sequence in reverse, while following the instructions below:

1. Apply grease on the serrated area on the lower part of the steering shaft.
2. Tighten the mounting bolt to the specified torque.
3. Be careful about the orientation when installing the elbow on the steering valve. Tighten it to the specified torque.

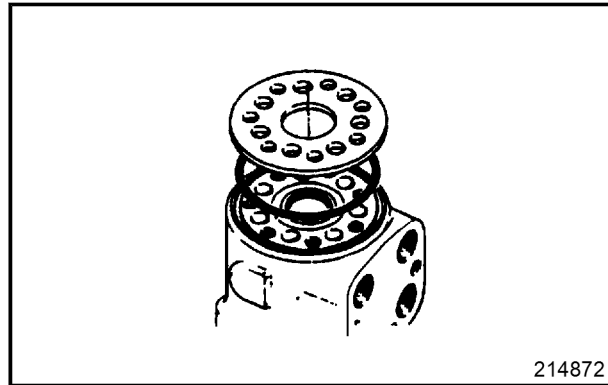
CLICK HERE TO **DOWNLOAD** THE COMPLETE MANUAL

- Thank you very much for reading the preview of the manual.
- You can download the complete manual from: [www.heydownloads.com](http://www.heydownloads.com) by clicking the link below



- Please note: If there is no response to CLICKING the link, please download this PDF first and then click on it.

CLICK HERE TO **DOWNLOAD** THE COMPLETE MANUAL

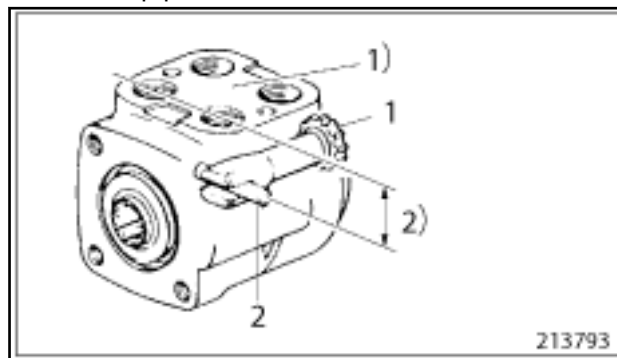


**Figure 10-22.**

7. Installing drive shaft

Turn the control spool-and-sleeve assembly so the port surface of the housing is parallel with the pin.

Insert the drive shaft to engage the pin in the yoke of the drive shaft. To insure positioning in the following work process, draw a line such as line B in the illustration below on the end face of the drive shaft spline with a felt-tip pen.



**Figure 10-23.**

1. DRIVE SHAFT

2. PIN

1) PORT SURFACE

2) PIN PARALLEL WITH PORT SURFACE

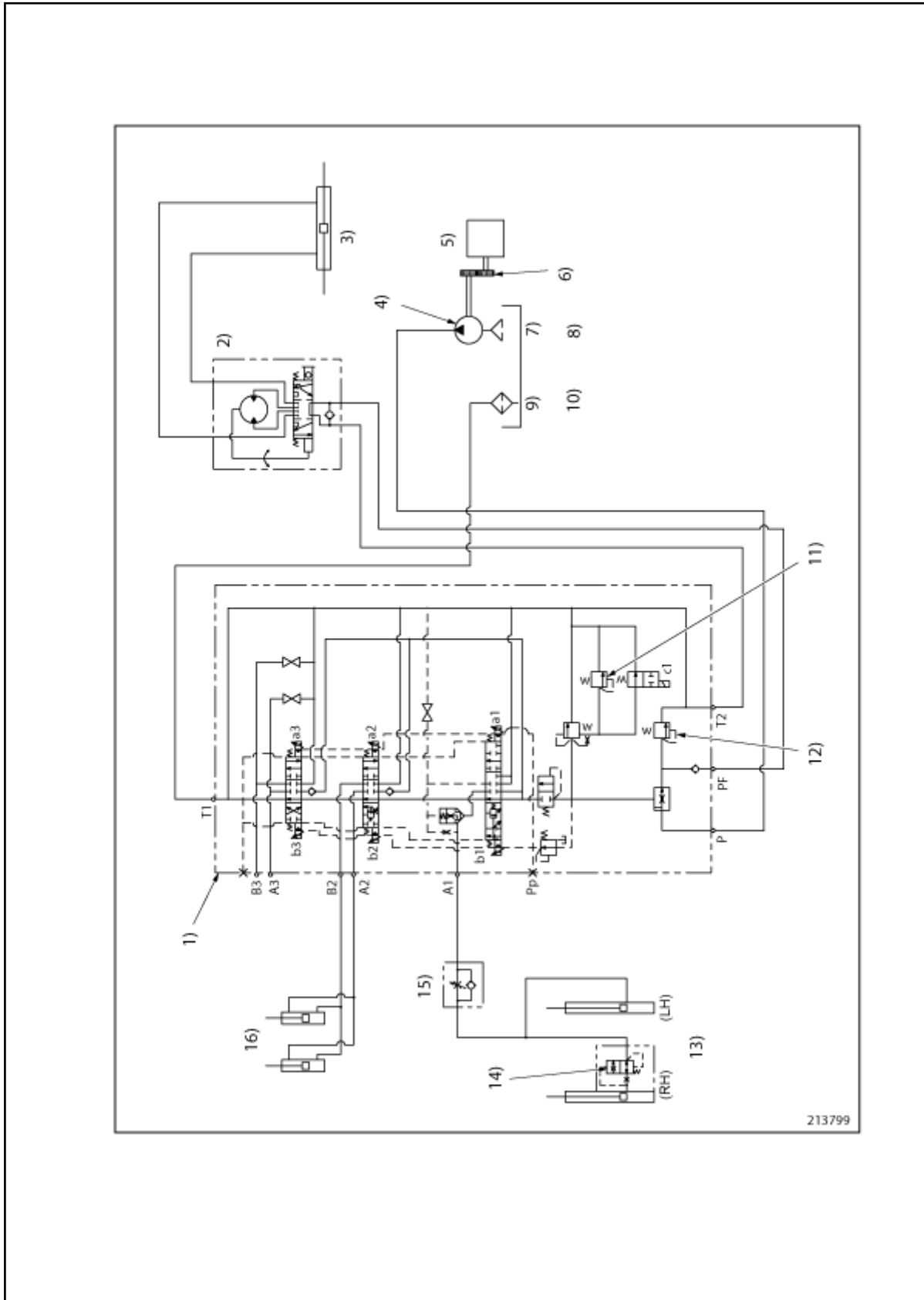
8. Installing gerotor set

Face the O-ring side of the rotor set toward the spacer plate side and fit the rotor set into the drive shaft by aligning the root (line A) of the rotor set with line B of the drive shaft.

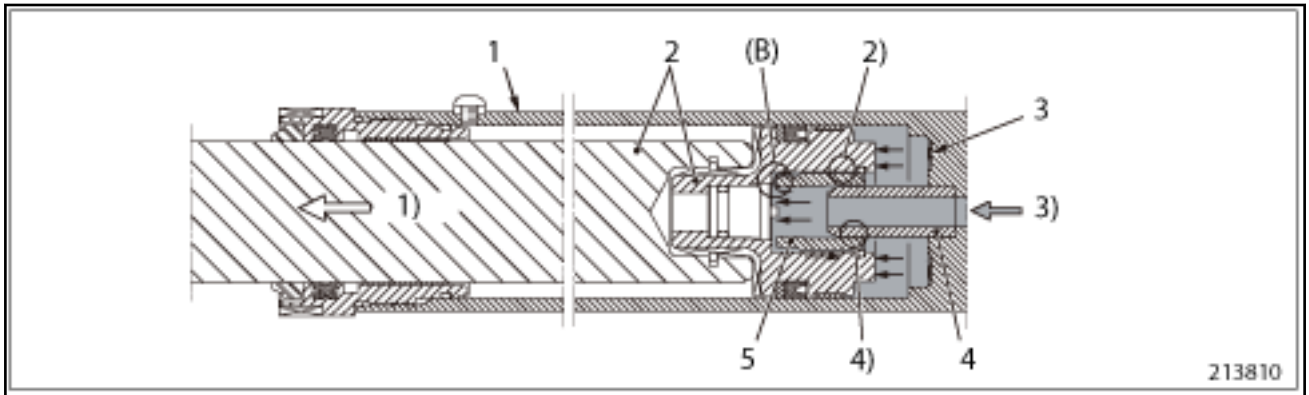
Check that lines A, B, C, and D are in parallel with each other. Align bolt holes of the "Gerotor" set with the drive shaft and star kept engaged.

This procedure is important in determining the valve timing of this unit.

11.1.3 HYDRAULIC CIRCUIT DIAGRAM (FOR MODELS WITH FC CONTROL VALVE)



Action during piston ascent (initial stage)



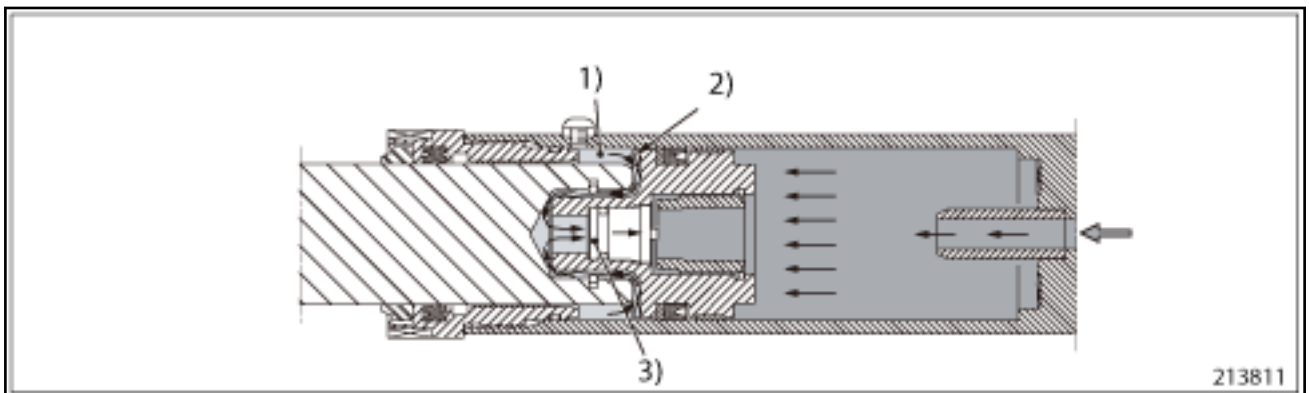
- |                        |                    |
|------------------------|--------------------|
| 1. CYLINDER TUBE       | 4. PIPE            |
| 2. PISTON ROD ASSEMBLY | 5. CUSHION BEARING |
| 3. GROOVE              |                    |
| 1) ASCENT              | 3) INFLOW          |
| 2) PASSAGE (A)         | 4) PASSAGE (B)     |

The above illustration shows an example of the following:

As the piston rod assembly descends, the oil flows through the center of the piston and causes the cushion bearing 5 to descend at the same time. The oil flowing in through the center of the piston activates the cushion bearing.

This action opens the (B) area, causing the passage (a) to open. Oil from the passage (a) and passage (b) which opens from the beginning flows in the piston bottom, acting on the entire bottom surface of the piston and pushing piston rod assembly 2 upward.

**Cylinder of internal drain type**



- |                                                                                       |                |
|---------------------------------------------------------------------------------------|----------------|
| 1) ENTRAPPED OIL AND AIR (THERE NORMALLY TENDS TO BE NEGATIVE PRESSURE IN THIS AREA.) | 3) CHECK VALVE |
| 2) GROOVE                                                                             |                |

2. When disassembling, do not remove the body, gear, and bushing by forcibly tapping them with a hammer.
3. Place disassembled parts in orderly sequence. DO not mistake the relative position of the gear and bushing side plate in particular.

### Inspection and Repair

1. Drive and driven gears
  - a. Check the gear teeth for wear, chipping, or other defects.
  - b. Check the side faces of the gears for wear or damage.
  - c. Check the shafts for wear or damage.
2. Covers, body, and bushings

### Assembly

To assemble, follow the disassembly sequence in reverse. Also follow the instructions listed below:

1. Replace the seal kit parts with new ones.
2. Completely remove oil or grease on the mating surfaces of covers 1, 2, and body 8.
3. Visually check all the parts for cleanliness and apply hydraulic oil on the inside surface of the body before assembly.
4. Apply grease on the lip of the shaft seal.
5. Be careful not to cause damage to the lip of shaft seal by spline edges of drive gear 5.
6. Tighten the bolts evenly and progressively.
7. The pump is assembled properly if the pipe wrench fitted on the pump shaft can be turned easily by hand.

### Test operation

Perform test operation after installing the pump.

1. Check that the oil amount in the hydraulic tank is sufficient.
2. Attach a pressure gauge on the pump delivery hose.  
See "11.6.1.4 MAIN RELIEF VALVE".
3. Start the engine, adjust the adjusting screw of the main relief valve in sequence from 0 to 18.1 MPa (0 to 185 kgf/cm<sup>2</sup>) [0 to 2625 psi], and check the temperature rise of the pump body by touching it by hand. If the temperature rise of the pump body is substantial compared to the oil temperature rise, disassemble again for checking.
4. Set the relief valve to the specified pressure.
5. Measure the lifting speed of the forks without a load. If the speed is to the specified value, the pump discharge volume is normal.
6. Check that the forks operate normally by raising and lowering it under load.

FIRST, DISASSEMBLE INTO THE THREE MAIN PARTS: I, II, AND III AS SHOWN ABOVE: THEN DISASSEMBLE EACH OF THE THREE MAIN PARTS INDIVIDUALLY.

I HEAD SUB-ASSEMBLY (CONSISTING OF THE FOLLOWING PARTS, 1 THRU 5.)

- |                  |            |
|------------------|------------|
| 1. CYLINDER HEAD | 4. O-RING  |
| 2. WIPER RING    | 5. BUSHING |
| 3. X-RING        |            |

II PISTON ROD SUB-ASSEMBLY (CONSISTING OF THE FOLLOWING PARTS, 6 THRU 13.)

- |                        |                     |
|------------------------|---------------------|
| 6. PISTON ROD ASSEMBLY | 10. SNAPRING        |
| 7. BACKUP RING         | 11. CUSHION BEARING |
| 8. U-RING              | 12. CHECK VALVE     |
| 9. BUSHING             | 13. O-RING          |

III CYLINDER TUBE ASSEMBLY (CONSISTING OF THE FOLLOWING PARTS, 14 AND 15.)

- |                                |          |
|--------------------------------|----------|
| 14. CYLINDER TUBE SUB-ASSEMBLY | 15. PLUG |
|--------------------------------|----------|
- 1) APPLY LIQUID GASKET TO CIRCUMFERENCE WHEN PRESSING IN.
  - 2) TIGHTENING TORQUE  
 1 TON CLASS: 196±45.1 N·M (20±4.6 KGF·M) [145±33 LBF·FT](M49X1.5)  
 2 TON CLASS: 235±53.9 N·M (24±5.5 KGF·M) [173±40 LBF·FT](M54X1.5)  
 3 TON CLASS: 275±61.8 N·M (28±6.3 KGF·M) [203±46 LBF·FT](M59X1.5)
  - 3) APPLY GREASE WHEN ASSEMBLING.
  - 4) APPLY THREEBOND ®1901 WHEN SCREWING IN.
  - 5) SEAL IN GREASE. (ADHESION TO BUSHING IS ACCEPTABLE.)

**NOTE:** The illustration shows a cylinder of the internal drain type without a return pipe. For structure of the cylinder with a return pipe, see "11.2.2 LIFT CYLINDER".

### Suggestions for Disassembly

#### Pulling out piston

Be careful not to damage the piston seals and cylinder bore wall when pulling out the piston from the cylinder.

#### Inspections after Disassembly

1. Cylinder tube
  - a. Check the bore wall for wear, grooving, scratches, or rust.
  - b. Check the welds for cracks or other defects.
2. Piston rod
  - a. Check the rod for deflection ( $\frac{1}{2}$  TIR).

## 11.2.4.1 DISASSEMBLY AND ASSEMBLY

## Disassembly

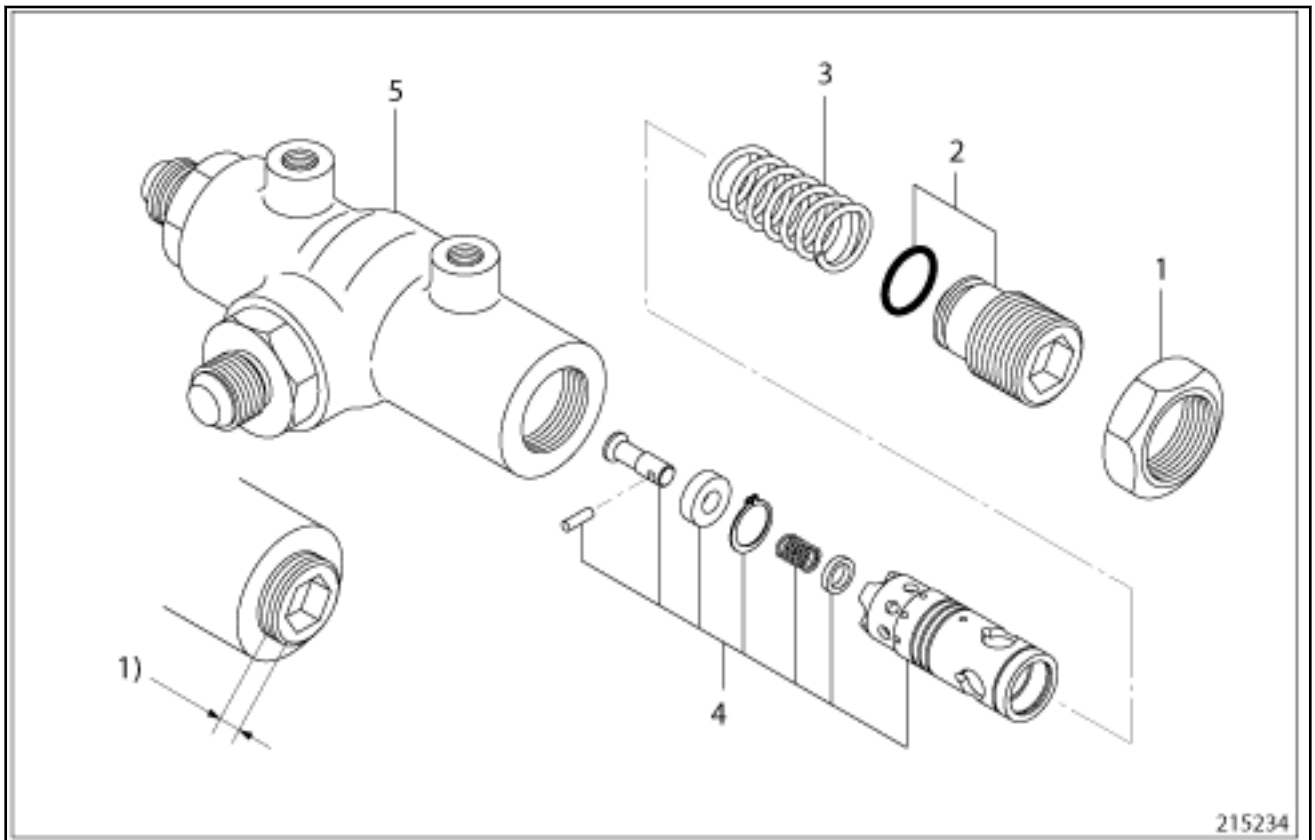


Figure 11-20.

## SEQUENCE

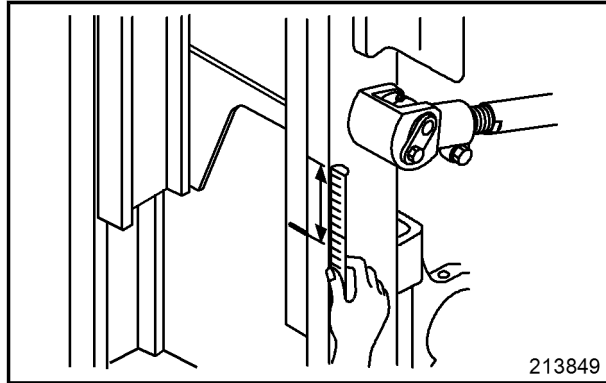
- |    |              |    |                                    |
|----|--------------|----|------------------------------------|
| 1. | LOCKNUT      | 4. | PISTON, PIN, WASHER, SPRING, VALVE |
| 2. | PLUG, O-RING | 5. | VALVE BODY                         |
| 3. | SPRING       |    |                                    |
| 1) | MEASURE      |    |                                    |

**NOTE:** Before disassembling, measure the protrusion of the plug. When assembling, adjust the protrusion as before.

**Inspections after Disassembly**

1. Check the spring for fatigue.
2. Check the sliding and contact surfaces of valve and piston for damage.
3. Check the sliding surfaces of piston and valve body for damage.

**NOTE:** Replace the flow regulator valve as an assembly if any part is defective.

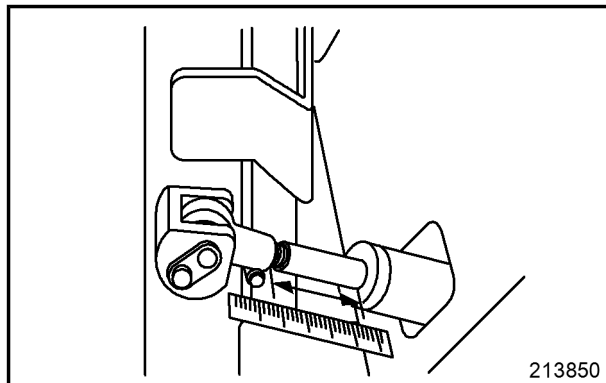


**11.3.4 FORWARD TILT TEST**

1. Pick up a load equal to the rated capacity, place the mast to the VERTICAL position, lift the forks about 50 cm (20 in.), and turn the engine OFF.
2. Measure the extension of tilt cylinder piston rod for 15 minutes.

Unit: mm (in.)/15 min		
Items	Truck type	
	1 ton class	2 ton class 3 ton class
Amount of forward (extension of piston rods) with rated load	20 (0.8) or less	

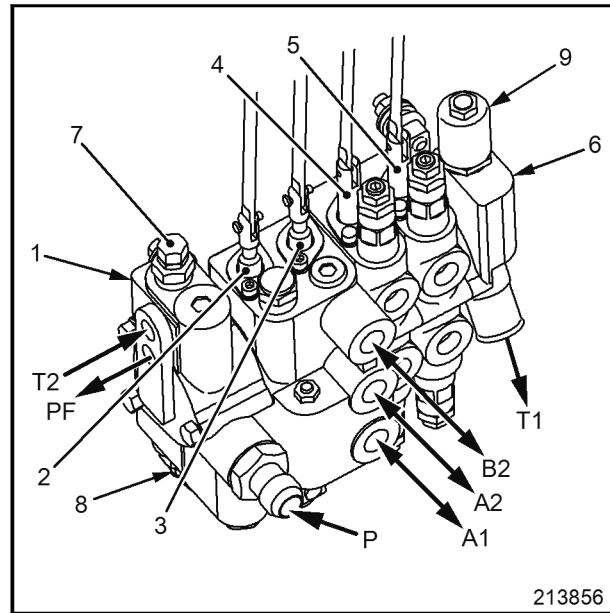
**Table 11-8.**



## 11.6 MC CONTROL VALVE

### 11.6.1 STRUCTURE AND OPERATION

#### 11.6.1.1 MC CONTROL VALVE



**Figure 11-21.**

P : PRESSURE OIL INFLOW PORT FROM PUMP  
 PF : TO STEERING CONTROL VALVE  
 T1 : TO HYDRAULIC TANK (RETURN LINE)  
 T2 : RETURN FROM STEERING CONTROL VALVE

A1 : TO LIFT CYLINDER  
 A2 : TO TILT CYLINDER ROD END  
 B2 : TO TILT CYLINDER HEAD END

#### MAIN VALVES

- |                                                       |                                                   |
|-------------------------------------------------------|---------------------------------------------------|
| 1. INLET COVER SECTION (WITH BUILT-IN PRIORITY VALVE) | 6. END COVER SECTION (WITH BUILT-IN UNLOAD VALVE) |
| 2. LIFT VALVE (WITH BUILT-IN FLOW REGULATOR VALVE)    | 7. STEERING SYSTEM RELIEF VALVE                   |
| 3. TILT VALVE                                         | 8. MAIN RELIEF VALVE                              |
| 4. ATTACHMENT VALVE (1)                               | 9. UNLOAD VALVE (WITH SOLENOID)                   |
| 5. ATTACHMENT VALVE (2)                               |                                                   |

The above illustration shows an external view of the four-valve type MC control valve. Any one of the two valve to five-valve type valves is installed on a lift truck depending on the truck specifications.

The most basic valve configuration is a two-valve type, combination of the lift and tilt. Adding attachment valve(s) to this combination is three-valve type, four-valve type or five-valve type valve.

## 11.6.1.7 TILT VALVE

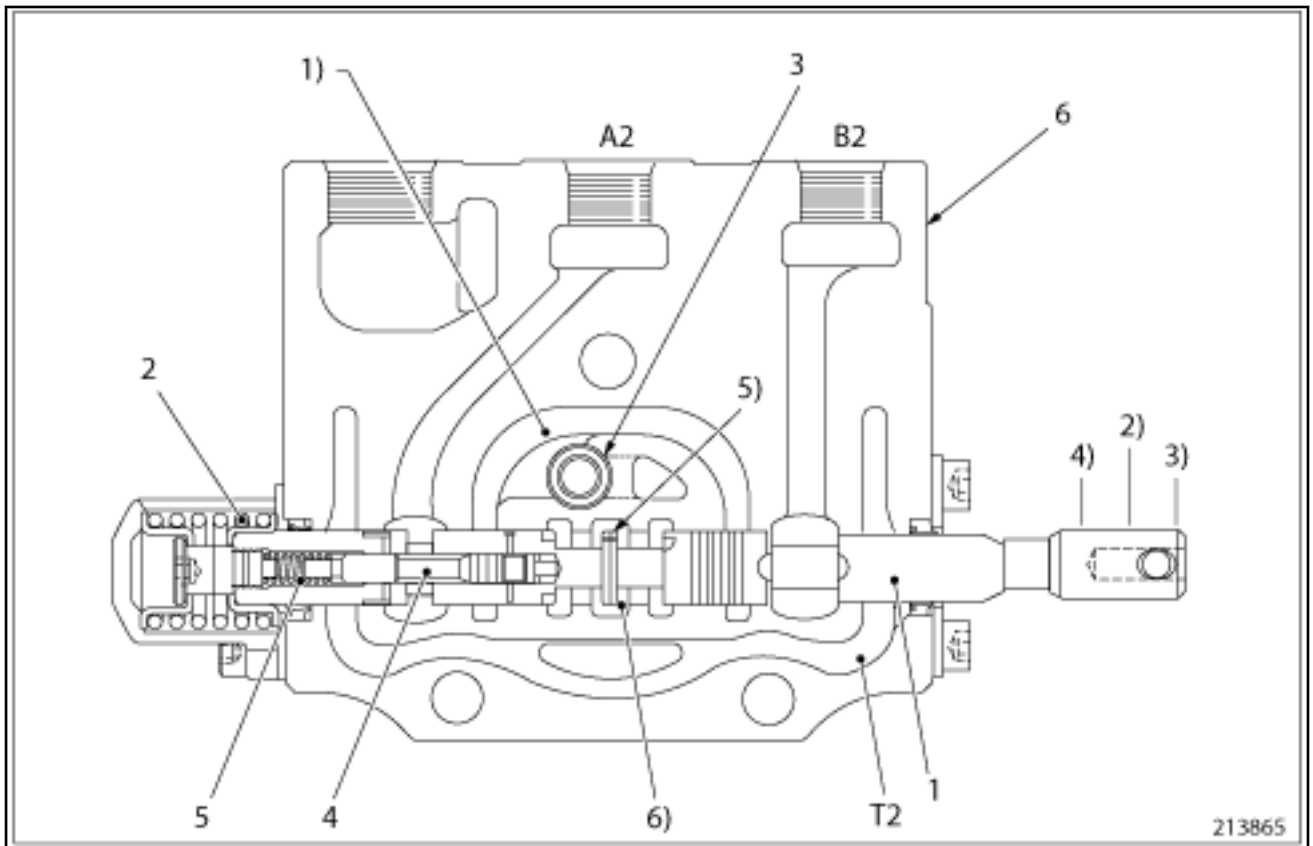


Figure 11-25.

## MAIN COMPONENTS

- |    |                                   |    |                                 |
|----|-----------------------------------|----|---------------------------------|
| 1. | TILT SPOOL                        | 4. | TILT LOCK VALVE                 |
| 2. | RETURN SPRING                     | 5. | TILT LOCK VALVE SPRING          |
| 3. | CHECK VALVE                       | 6. | VALVE BODY                      |
| 1) | PASSAGE A (HIGH-PRESSURE PASSAGE) | 4) | FORWARD TILT                    |
| 2) | BACKWARD TILT                     | 5) | HOLE                            |
| 3) | NEUTRAL                           | 6) | CENTER BYPASS PORT              |
|    | A2 : TO TILT CYLINDER ROD         |    | T2 : TANK PORT (RETURN PASSAGE) |
|    | B2 : TO TILT CYLINDER HEAD        |    |                                 |

The above illustration shows the tilt control valve when spool 1 is at the "NEUTRAL position."

**Neutral position**

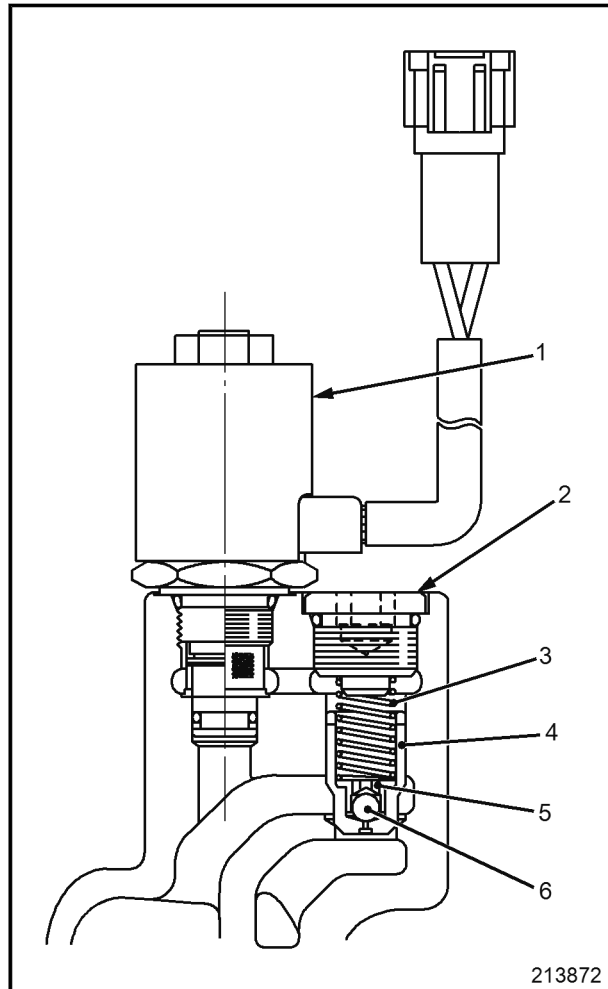
Spool 1 is placed at the "NEUTRAL position." by return spring 2, and both the A2 port and B2 port are blocked by the spool.

As the center bypass valve is open, oil in the bypass port flows in the attachment valve.

**NOTE:** DO NOT disassemble and adjust the shutoff valve 15 and flow regulator valve 16.

### 11.6.3.3 END COVER SECTION

#### Disassembly of Unload Valve



**Figure 11-30.**

#### SEQUENCE

- |                   |                    |
|-------------------|--------------------|
| 1. SOLENOID VALVE | 4. VALVE           |
| 2. PLUG, O-RING   | 5. SPRING RETAINER |
| 3. SPRING         | 6. BALL            |

#### Inspections after Disassembly

##### Valve, spool, and return spring

1. Check the valve body for cracks, damaged sliding surface, and wear of check valve seat.
2. Check the spool for damage, seizure, bend, and operating force.
3. Check the tilt lock valve for damage and seizure.

## Main Relief Valve, Pilot Relief Valve and Unload Valve

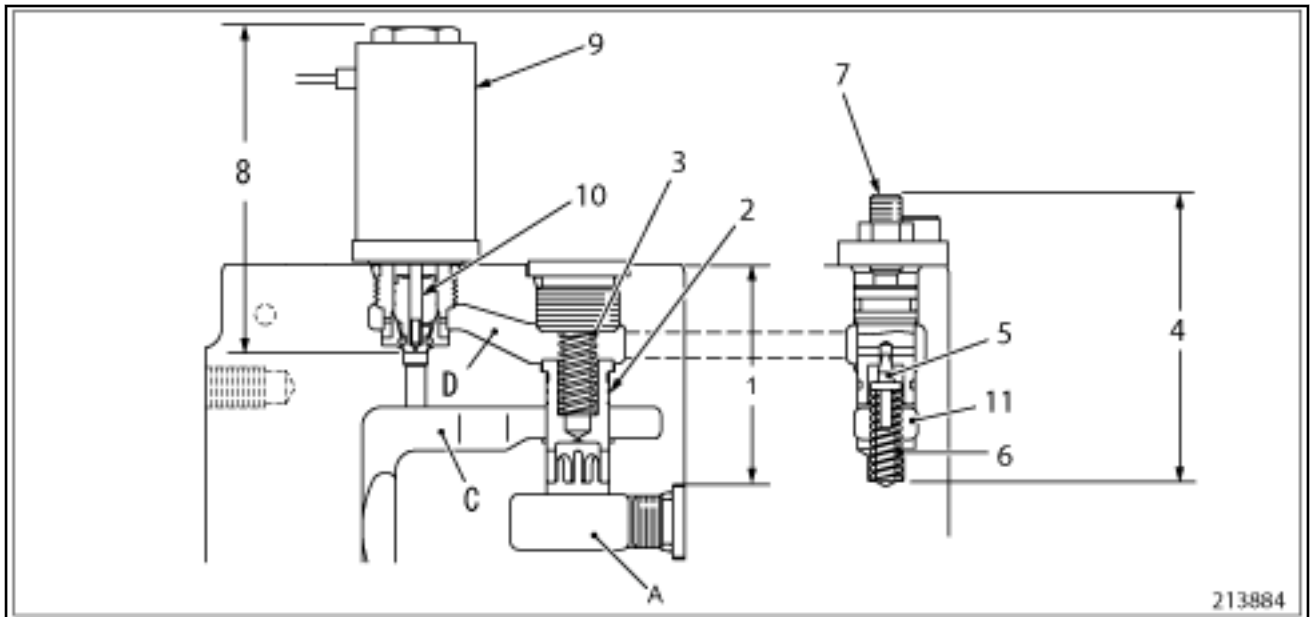


Figure 11-34.

- |                       |                             |
|-----------------------|-----------------------------|
| 1. MAIN RELIEF VALVE  | 7. PRESSURE ADJUSTING SCREW |
| 2. DUMP VALVE         | 8. UNLOAD VALVE             |
| 3. SPRING             | 9. SOLENOID                 |
| 4. PILOT RELIEF VALVE | 10. NEEDLE VALVE            |
| 5. POPPET VALVE       | 11. DRAIN PASSAGE           |
| 6. SPRING             |                             |

A: EXTRA FLOW (EF FLOW) PASSAGE

D: OIL PASSAGE

C: DRAIN PASSAGE

**Function of Component Valves**

The pilot relief valve 4 and unload valve 8 are arranged in parallel to serve as pilot valves for the main relief valve 1.

To be more specific, when either valve 4 or 8 opens, the dump valve 2 overcomes the force of the spring 3 to lift, releasing high pressure oil in the oil passage A into the drain passage C.

**Pilot Relief Valve 4**

This is a pilot valve for the main relief valve. When pressure in the system exceeds the specified limit, the poppet valve 5 overcomes the force of the spring 6 to move downward, releasing oil in the back of the dump valve 2 into the drain passage. As a result, the dump valve of the main relief valve lifts to release some of EF flow into the drain passage.

The screw 7 is for set pressure adjustment. Turning it clockwise increases set pressure. For set pressure and setting procedure, see "11.3 INSPECTION AND ADJUSTMENT".

**Actuation of Tilt Lock Valve in Case of Emergency**

In case the main spool is stuck for some reason when the mast tilts forward, returning the tilt lever to the "NEUTRAL" position stops the movement of the cylinder rod.

With the tilt lever back in the "NEUTRAL" position, the unload valve of the inlet valve assembly is opened to release extra flow of oil into the drain passage through the main relief valve.

As a result, oil pressure in the passage 13 is reduced, and oil pressure of the damper (e) is also reduced. When this takes place, the tilt lock valve 3 is pushed to the right by the spring 7 and the route connecting the port A2 and low-pressure passage 10 is closed.

The tilt cylinder rod is brought into a locked state.

**11.7.1.5 ATTACHMENT VALVE ASSEMBLY**

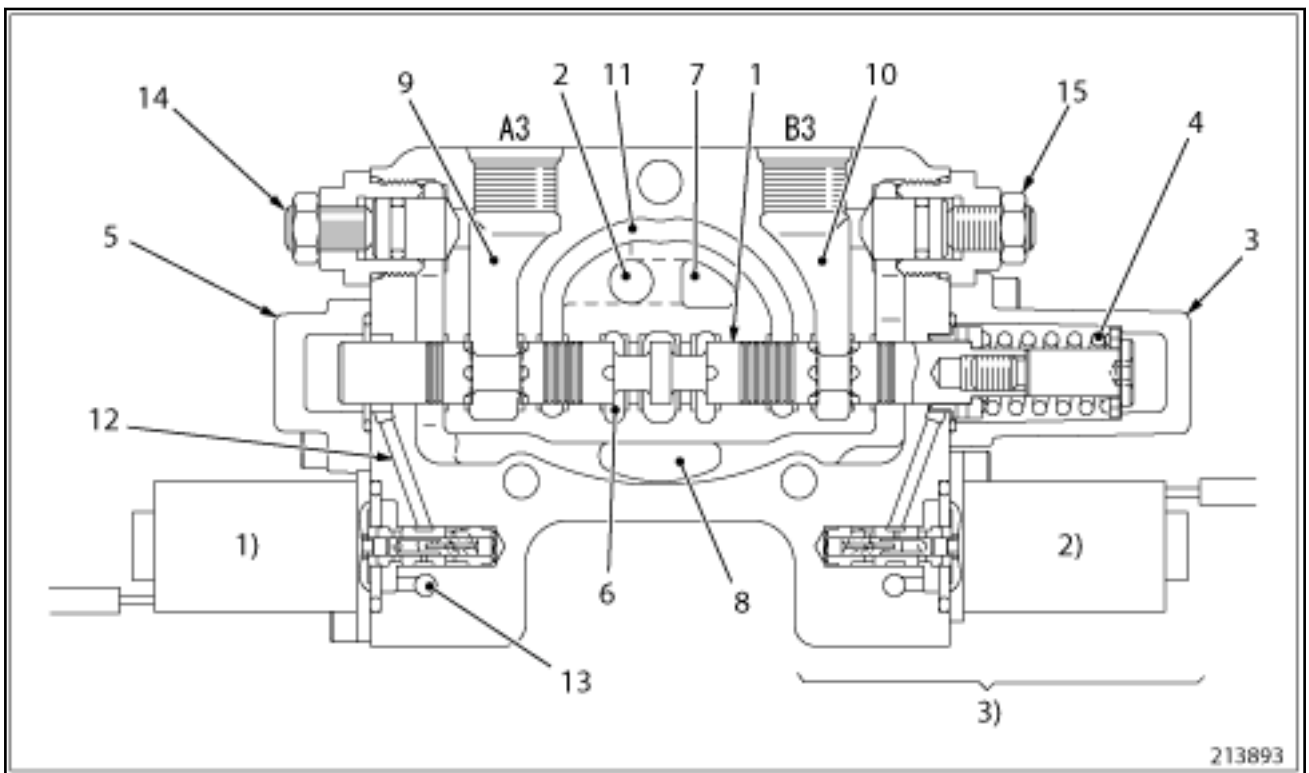


Figure 11-39.

ASSEMBLY OF PILOT RELIEF VALVE (1 TO 9)

- |           |            |
|-----------|------------|
| 1. SPRING | 6. PLATE   |
| 2. VALVE  | 7. SCREW   |
| 3. SLEEVE | 8. LOCKNUT |
| 4. O-RING | 9. BOLT    |
| 5. O-RING |            |

ASSEMBLY OF PRIORITY VALVE (10 TO 15)

- |               |                                            |
|---------------|--------------------------------------------|
| 10. SPOOL SET | 13. SPRING (FREE LENGTH: 43.5 MM (1.7IN.)) |
| 11. PLUG      | 14. PLUG                                   |
| 12. O-RING    | 15. O-RING                                 |

ASSEMBLY OF RESISTANCE VALVE (16 TO 20)

- |                                          |            |
|------------------------------------------|------------|
| 16. SPOOL                                | 19. PLUG   |
| 17. SPRING (FREE LENGTH: 36 MM (1.4IN.)) | 20. O-RING |
| 18. SLUG                                 |            |

ASSEMBLY OF PF RELIEF VALVE (STEERING RELIEF VALVE) (21 TO 30)

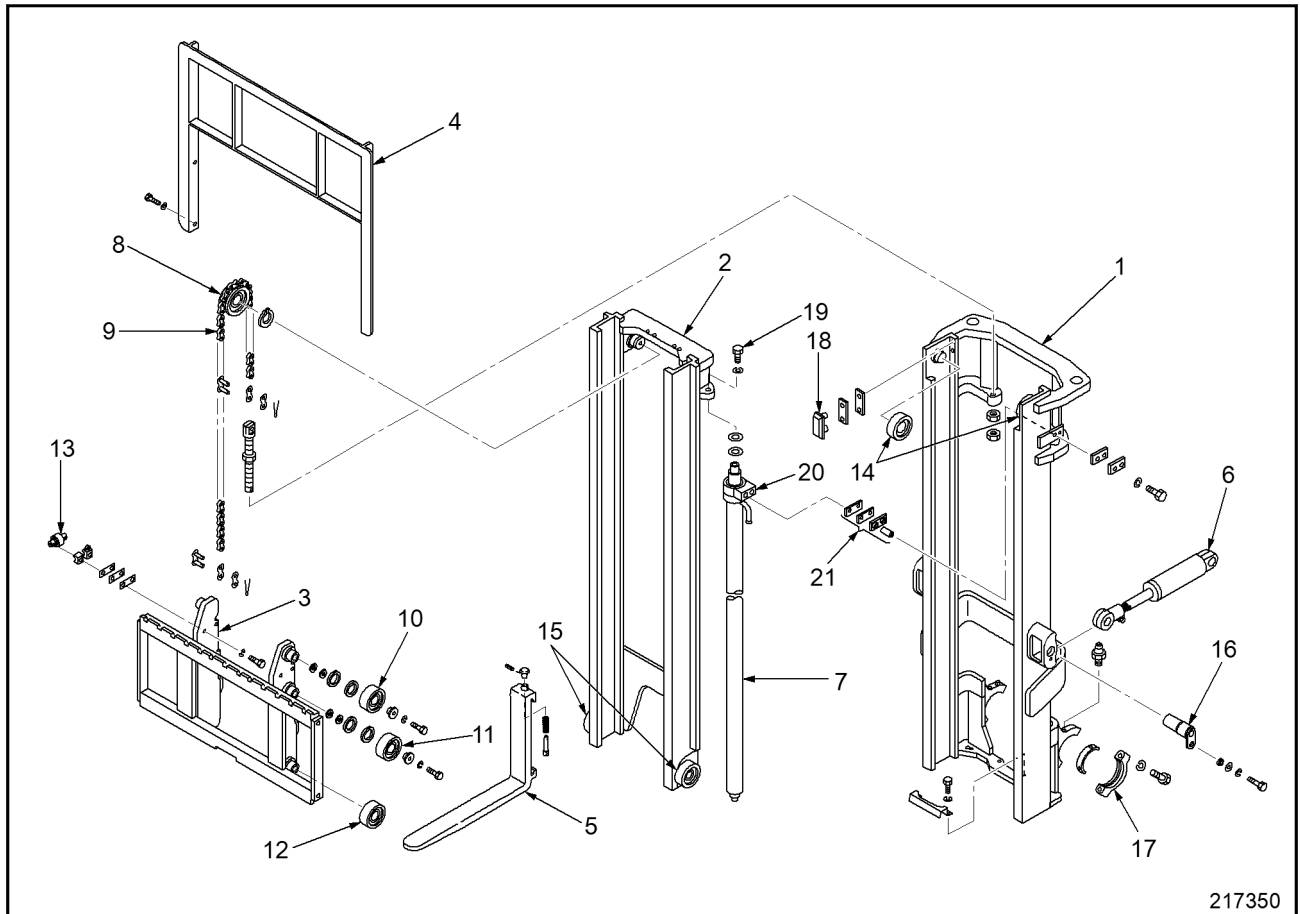
- |                  |                           |
|------------------|---------------------------|
| 21. SPRING       | 26. SCREW                 |
| 22. POPPET       | 27. LOCKNUT               |
| 23. RELIEF VALVE | 28. BOLT                  |
| 24. O-RING       | 29. PLUG (WITH O-RING 20) |
| 25. PLATE        | 30. O-RING                |
- 
- |                                                                                               |                                                                                                        |
|-----------------------------------------------------------------------------------------------|--------------------------------------------------------------------------------------------------------|
| 1) TIGHTENING TORQUE: 15.7 ± 1.6 N·M (1.6 ± 0.16 KGF·M) [11.5 ± 1.0 LBF·FT]                   | 5) TIGHTENING TORQUE AFTER SET PRESSURE ADJUSTMENT: 9.8 ± 1.0 N·M (1.0 ± 0.1 KGF·M) [7.2 ± 0.7 LBF·FT] |
| 2) TIGHTENING TORQUE: 63.7 ± 6.4 N·M (6.5 ± 0.65 KGF·M) [47 ± 4.7 LBF·FT]                     | 6) TIGHTENING TORQUE: 15.7 ± 1.6 N·M (1.6 ± 0.16 KGF·M) [11.5 ± 1.0 LBF·FT]                            |
| 3) TIGHTENING TORQUE: TIGHTENING FIRST: 34.1 ± 3.4 N·M (3.5 ± 0.35 KGF·M) [25.3 ± 2.5 LBF·FT] | 7) TIGHTENING TORQUE: 63.7 ± 6.4 N·M (6.5 ± 0.65 KGF·M) [47 ± 4.7 LBF·FT]                              |
| 4) FURTHER TIGHTENING: 34.1 ± 3.4 N·M (3.5 ± 0.35 KGF·M) [25.3 ± 2.5 LBF·FT]                  | 8) TIGHTENING TORQUE AFTER SET PRESSURE ADJUSTMENT: 9.8 ± 1.0 N·M (1.0 ± 0.1 KGF·M) [7.2 ± 0.7 LBF·FT] |

**Pilot relief valve**

1. Insert the spring 1 and valve 2 into place in the housing.
2. Fit the O-rings 4 and 5 on the sleeve 3. Apply grease around the O-rings and push the sleeve 3 into place in the housing.
3. If the screw 7 for set pressure adjustment was disassembled, drive the screw in the plate 6 and install the locknut 8 hand-tight.
4. Install the plate completed as above using the bolt 9. Tighten the bolt to the specified torque.

12.2 STRUCTURE AND FUNCTIONS

12.2.1 SIMPLEX (DUAL PANORAMIC) MAST (5V15C TO 5V35C)



217350

Figure 12-1.

MAJOR COMPONENTS (MOST PARTS  
COME IN PAIRS, LEFT AND RIGHT)

- |                                |                                           |
|--------------------------------|-------------------------------------------|
| 1. OUTER MAST                  | 12. LIFT BRACKET LOWER ROLLER             |
| 2. INNER MAST                  | 13. SIDE ROLLER                           |
| 3. LIFT BRACKET                | 14. OUTER MAST ROLLER                     |
| 4. BACKREST                    | 15. INNER MAST ROLLER                     |
| 5. FORK (2)                    | 16. TILT SOCKET MOUNTING PIN              |
| 6. TILT CYLINDER               | 17. MAST SUPPORT CAP                      |
| 7. LIFT CYLINDER               | 18. MAST STRIP                            |
| 8. CHAIN WHEEL                 | 19. LIFT CYLINDER UPPER MOUNTING<br>BOLTS |
| 9. CHAIN                       | 20. CYLINDER BRACKET                      |
| 10. LIFT BRACKET UPPER ROLLER  | 21. CYLINDER CLAMPS                       |
| 11. LIFT BRACKET MIDDLE ROLLER |                                           |

Move the lift bracket to the top of the inner mast and slide the bracket to either the left-most or right-most position. Take measurements of clearance G between the side surface of roller and inner mast.

**NOTE:** It is unnecessary to adjust the lift bracket upper roller with shims.

Adjust the clearance to the specification with shims (a) and (b) for the middle roller and with shim (c) for the lower roller.

Unit: mm (in.)	
Clearance G	0.1 to 0.5(0.004 to 0.020)

**Table 12-5.**

- Clearance F  
Clearance between roller circumference and inner mast thrust surface (back-to-front play): Clearance F is used for determining the proper size of the rollers. Select appropriate diameter rollers so that the clearance meets the specification. Make sure the rollers rotate smoothly when installed.

Unit: mm (in.)	
Clearance F	1.0 (0.04) or less

**Table 12-6.**

- Clearance G1  
Clearance between side roller circumference and inner mast side roller thrust surface: Move the side roller to the upper end of the inner mast and slide the lift bracket to either the left-most or right-most position. Take measurement of clearance G1 between the roller circumference and inner mast. Adjust the clearance with shims (d) to the specification.

Unit: mm (in.)	
Clearance G1	0.1 to 0.5 (0.004 to 0.020)

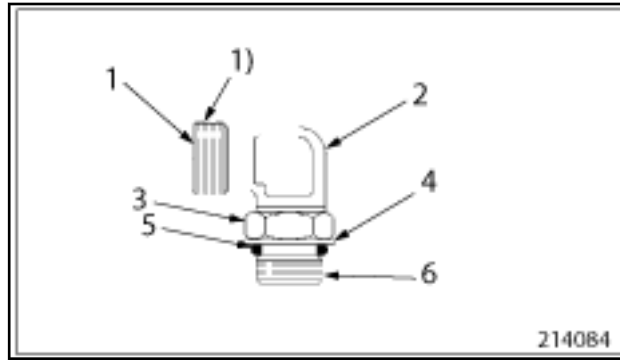
**Table 12-7.**

1. Choosing correct roller diameters
  - Measure clearance F for upper rollers 2, middle rollers 3, and lower rollers 4. If the measured clearances do not conform to the standard values, replace with rollers of correct diameters listed in the below table

**NOTE:** For measuring procedures, see "12.6.5 ADJUSTING CLEARANCE BETWEEN LIFT BRACKET ROLLER AND INNER MAST."

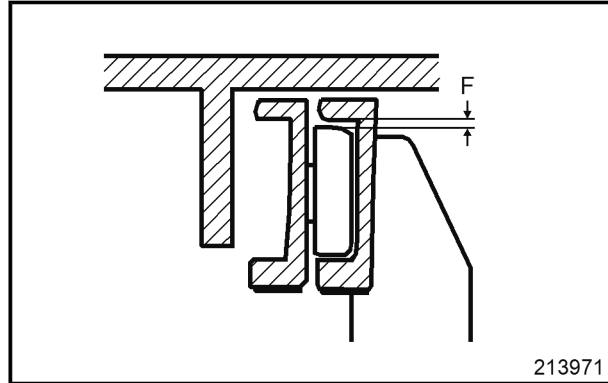
- Make sure that the rollers rotate smoothly when installed.
2. Adjusting clearance G between the middle roller and thrust plate

**NOTE:** The following adjustment is not required for the upper roller.

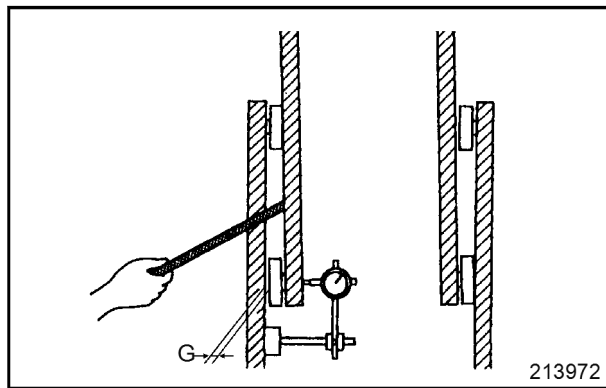


**Figure 12-6.**

- |                                                                                                                                                                                   |                                                                                                                                              |
|-----------------------------------------------------------------------------------------------------------------------------------------------------------------------------------|----------------------------------------------------------------------------------------------------------------------------------------------|
| <ul style="list-style-type: none"> <li>1. END OF FITTING BODY (CONNECTS TO TUBE)</li> <li>2. FITTING BODY</li> <li>3. LOCKNUT</li> <li>1) SHAPE VARIES BY FITTING TYPE</li> </ul> | <ul style="list-style-type: none"> <li>4. BACKUP WASHER</li> <li>5. O-RING SEAL</li> <li>6. END OF FITTING THAT GOES INTO HOUSING</li> </ul> |
|-----------------------------------------------------------------------------------------------------------------------------------------------------------------------------------|----------------------------------------------------------------------------------------------------------------------------------------------|



2. Right-to-left clearance inspection on inner mast main rollers
  - a. Raise the mast to the top.
  - b. Set a dial indicator on the inside of the outer mast with its contact point rested on the inner mast.
  - c. Go over to the opposite side of the mast, and push the inner mast against the outer mast. Set the indicator to zero.

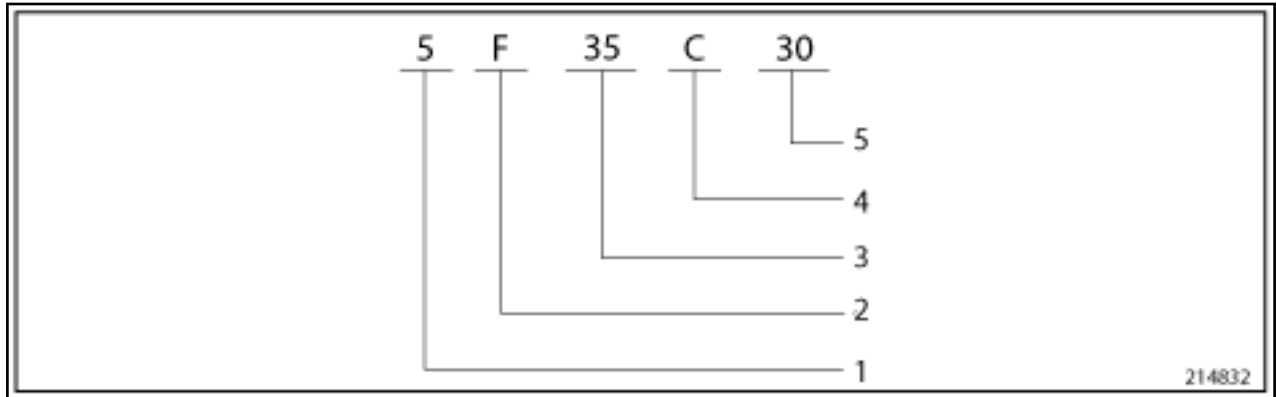


- d. Insert a bar between the outer and inner masts on the indicator side, and push the inner mast to the opposite side.
- e. Read the indicator. This reading is clearance  $G$  between the outer mast roller and inner mast.

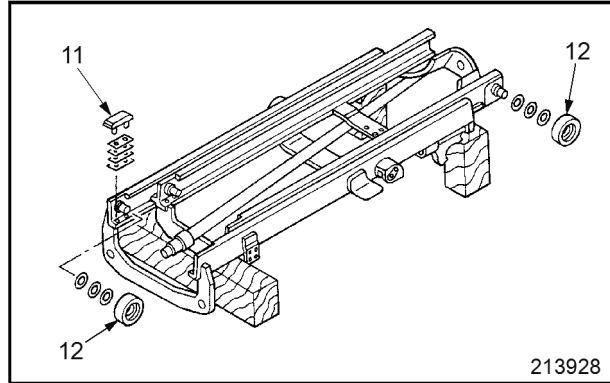
Unit: mm (in.)	
$G$	0.1 to 0.5 (0.004 to 0.020)

**Table 12-21.**

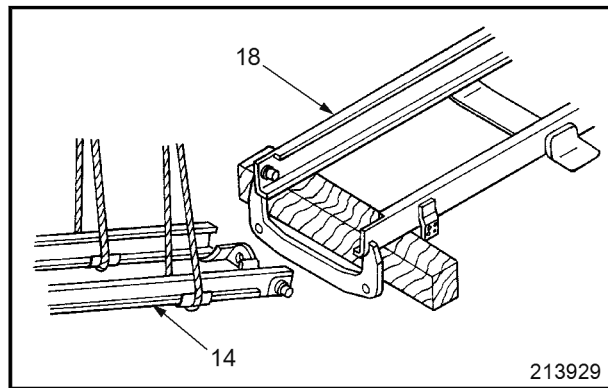
- f. If clearance  $G$  is out of specification, adjust it with shims.  
For adjustment and installation procedures, see "12.4.2.2 INSTALLING MAST ROLLERS."



- |                                              |                                        |
|----------------------------------------------|----------------------------------------|
| 1. TRUCK GENERATION (2→3→4→...9)             | 4. MAST GENERATION (A→B→C...Z)         |
| 2. INDICATES MAST TYPE                       | 5. MAXIMUM LIFTING HEIGHT (30:3000 MM) |
| 3. APPLICABLE TRUCK CLASS (EXAMPLE: 3.5 TON) |                                        |

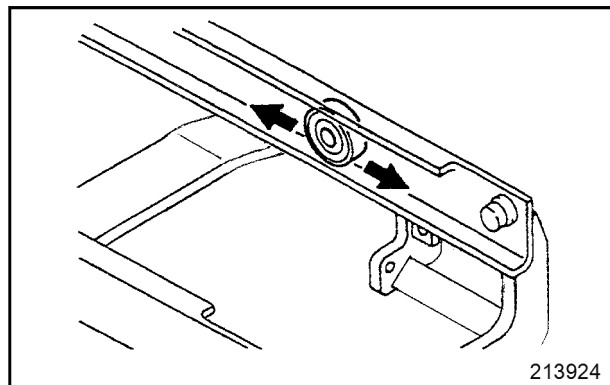


3. Removing inner mast  
Using slings, lift and remove inner mast, steering it clear of the roller shaft sections of outer mast.



**Inspections after Disassembly**

1. Mast
  - a. Check each roller for wear, binding, or other defects.
  - b. Check each roller on rolling surface for pitting or other defects.
  - c. Check the mast member and the welded joints of crossmembers shafts, and supports for cracks.
  - d. Check the mast support bushings for wear or other defects.



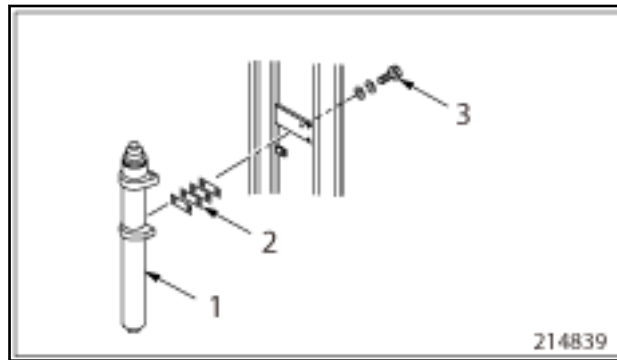
2. Lift bracket

- The perpendicularity of the cylinder in the lateral direction can be checked by measuring the distances between the cylinder and the side face of the inner mast. The difference of the distance at the top and bottom should be  $\pm 1$  mm (0.04 in.).
- The perpendicularity of the cylinder in the longitudinal direction can be checked by visually inspecting for the parallelism between the cylinder and the front face of the inner mast. The cylinder should not be inclined forward, not even slightly. The cylinder slightly inclined backward is acceptable.
- Each shim is 1 mm (0.04 in.) thick.

At the factory, a shim pack of 2 mm (0.08 in.) is usually inserted between the cylinder bracket and the inner mast on the standard model for shipment.

3. After shimming is completed, install and tighten the mounting bolts.

**NOTE:** Depending on the truck model, the direction in which the mounting bolts are inserted may be different from what is shown in the illustration.



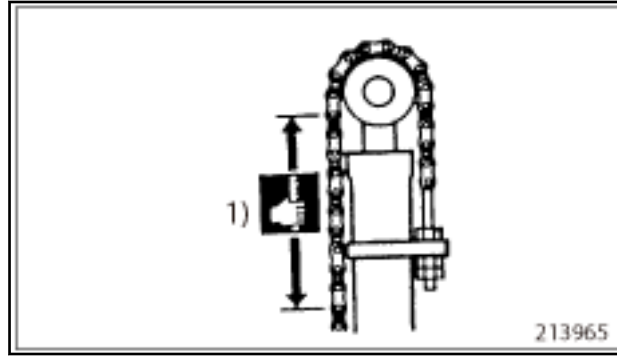
1. FIRST LIFT CYLINDER
2. SHIM
3. MOUNTING BOLT

**12.12.2.6 CONNECTING CHAINS**

Attach each chain on the lift bracket as shown. When attaching, maintain clearance between them using nuts to allow for the tension of the chain.

Unit: N·m (kgf·m) [lbf·ft]		
Item	Truck type	
	1 ton class 2 ton class	3 ton class
Locknut (single nut side)	56.0 0 -9.8 (5.71 0 -1.00) [41.30 0 -7.23]	84.3 0 -11.8 (8.60 0 -1.20) [62.18 0 -8.70]
Locknut (double nut side)	98 +49 0 (9.99 +5.00 0) [72.82 +36.14 0]	147 +49 0 (14.99 +5.00 0) [108.42 +36.14 0]

**Table 12-41.**



1) 20 LINKS

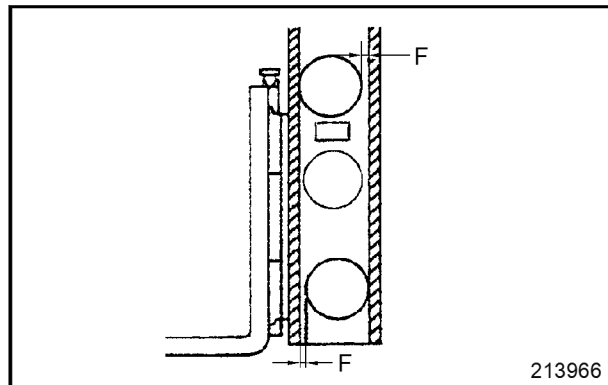
**12.14.5 ADJUSTING CLEARANCE BETWEEN LIFT BRACKET ROLLER AND INNER MAST**

1. Back-to-front clearance check on lift bracket main rollers
  - a. Raise the forks slightly from the ground.
  - b. Insert a bar between the upper part of lift bracket and the inner mast, and slide the inner mast to one side. Using feeler gauges, measure clearance F between the main roller and inner mast on the opposite side.

Unit: mm (in.)	
F	1 (0.04) maximum

**Table 12-45.**

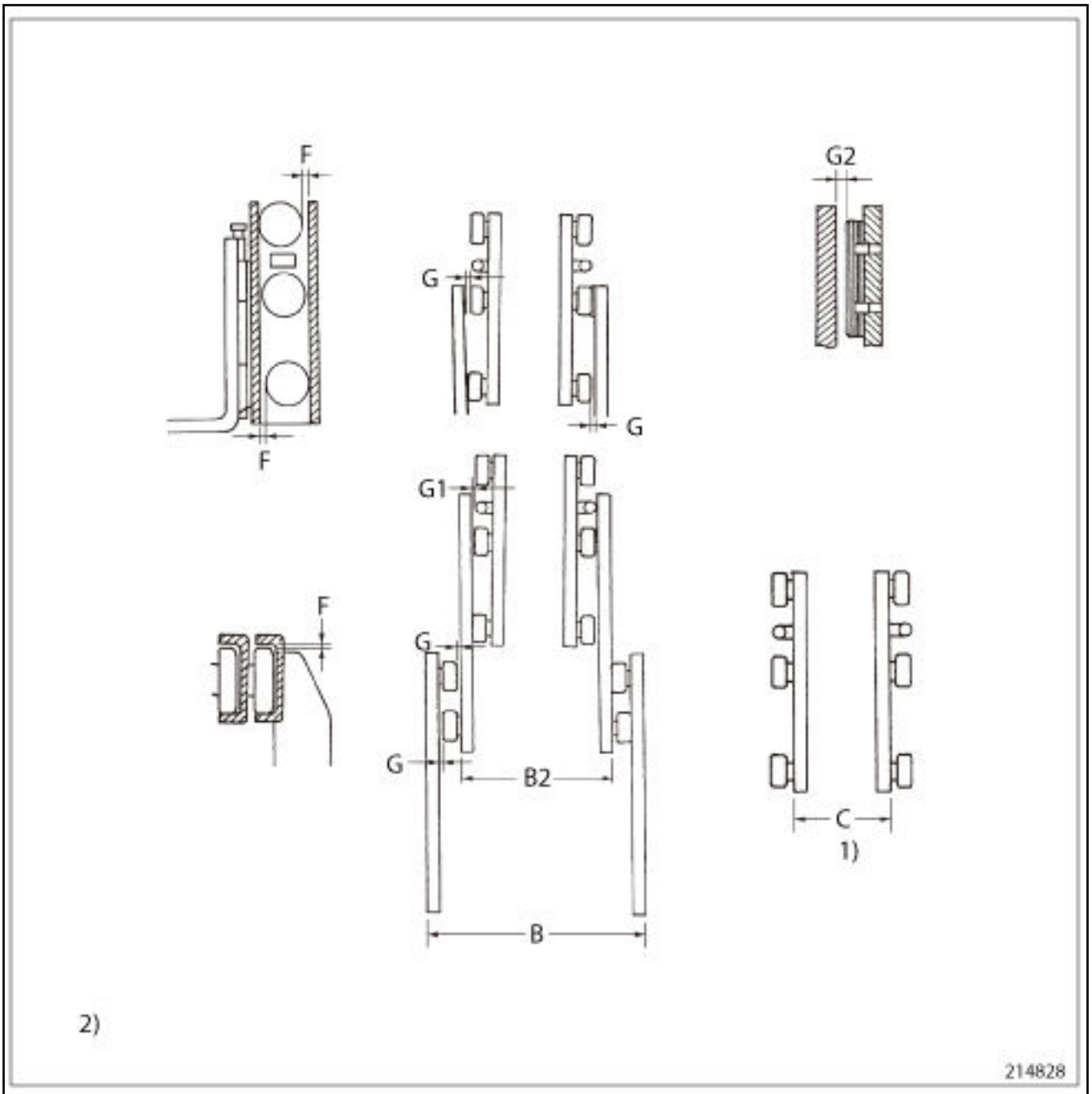
- c. If clearance is out of specification, use oversize rollers.  
For roller replacement procedure, see "12.12.2.1 INSTALLING LIFT BRACKET ROLLERS."



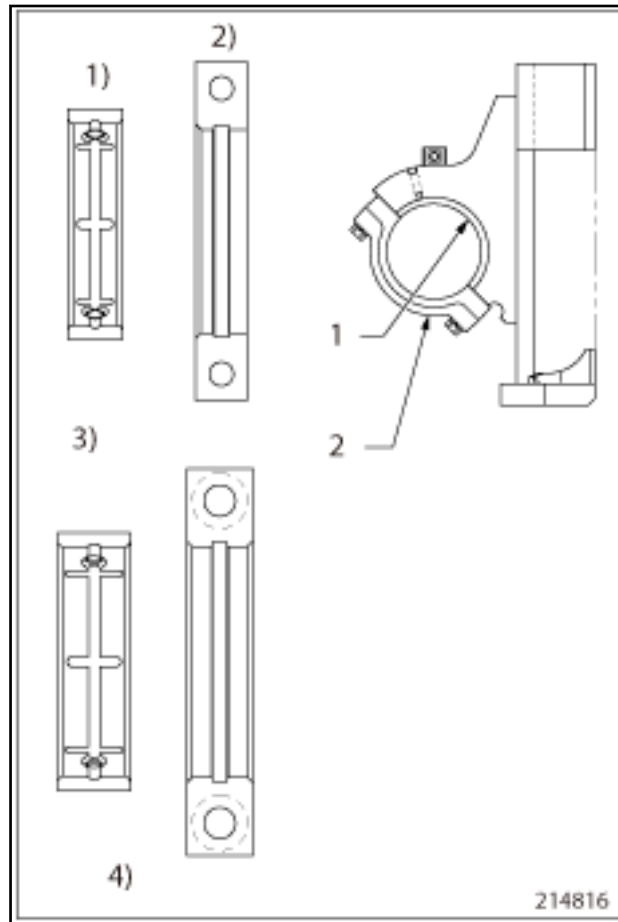
2. Right-to-left clearance check on lift bracket main rollers and side rollers
  - a. Raise the mast to the top.
  - b. Set a dial indicator on the inner mast with its contact point rested on the side of the lift bracket.
  - c. Go over to the opposite side of the mast, and slide the lift bracket to one side with a bar. Set the indicator to zero.

Unit: mm (in.)			
Item	Truck type		
	1 ton class	2 ton class	3 ton class
A: Standard value	B: Repair or service limit		

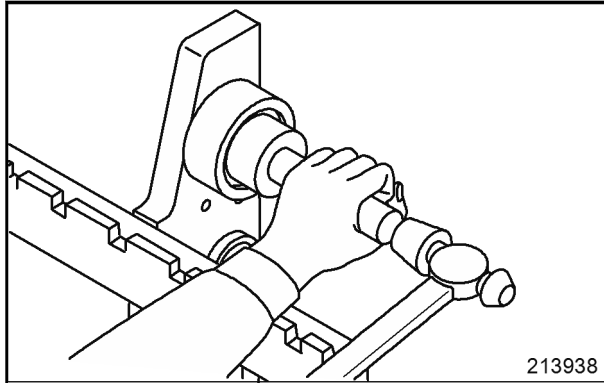
Table 12-54. (Continued)



3. Bleeding lift cylinders  
 Start the engine, raise and lower the lift bracket with several strokes to bleed the cylinder.  
 After proper operation is confirmed, check the oil level in the hydraulic tank.



- |    |               |    |                 |
|----|---------------|----|-----------------|
| 1. | BUSHING       | 2. | CAP             |
| 1) | INNER BUSHING | 3) | 1 TON CLASS     |
| 2) | INNER CAP     | 4) | 2-3 TON CLASSES |

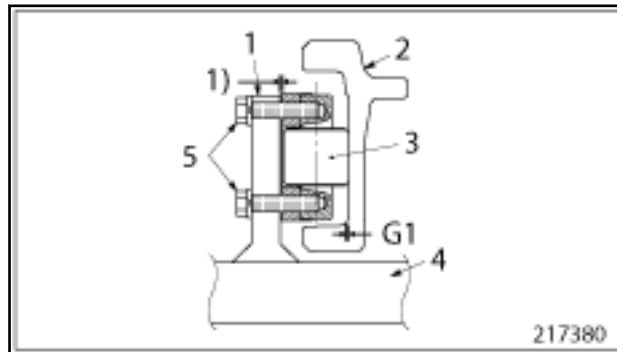


5. Adjusting clearance G1 between the side roller and inner mast
  - Measure clearance G1 between the side roller's rolling contact surface and inner mast. If the measured clearance does not conform to the standard value, adjust clearance G1 in the manner described below.

**NOTE:** For measuring procedures, see "12.22.5 ADJUSTING CLEARANCE BETWEEN LIFT BRACKET ROLLER AND INNER MAST"

- Adjusting method  
If clearance G1 is excessive, increase the thickness of shims (d) as required.

At the factory, shims (d) are usually adjusted to 1 mm (0.04 in.) for shipment.



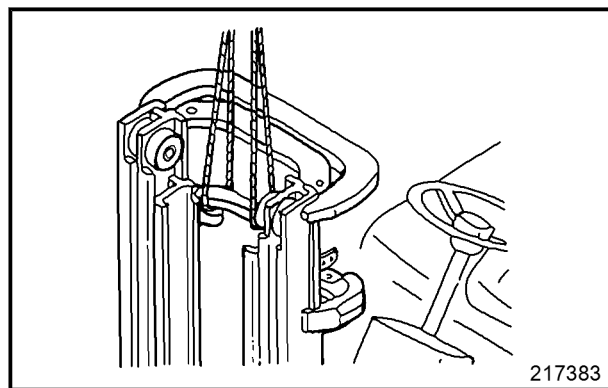
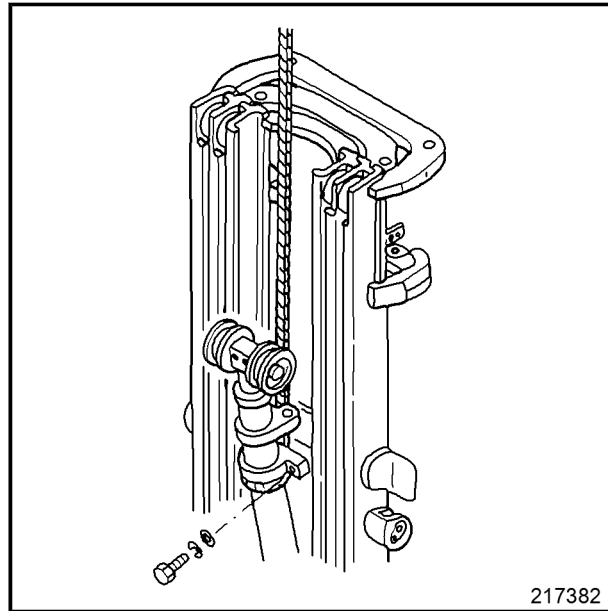
- |                 |                          |
|-----------------|--------------------------|
| 1. LIFT BRACKET | 4. LIFT BRACKET          |
| 2. INNER MAST   | 5. ROLLER MOUNTING BOLTS |
| 3. SIDE ROLLER  |                          |
| 1) SHIM (D)     |                          |

**12.20.2.2 INSTALLING MAST ROLLERS**

Mast rollers are identical in shape and size with lift bracket lower rollers.

Unit: mm (in.)	
Clearance F	1 (0.04) maximum

**Table 12-64.**

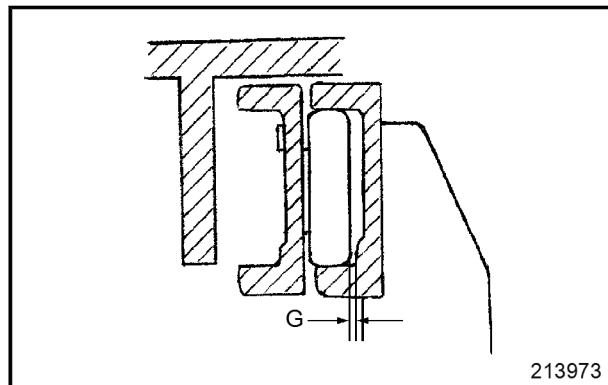
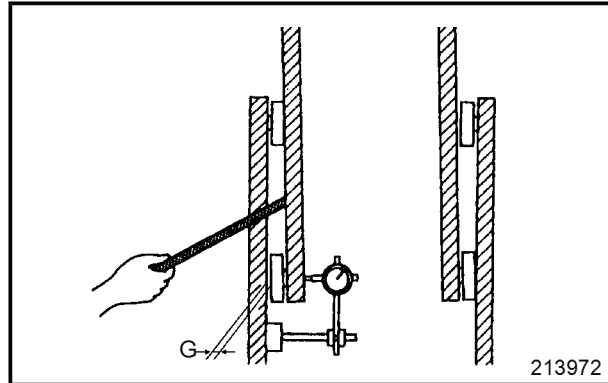


4. Place the middle mast lower than the outer mast as follows:
  - a. Lift the inner mast to the height of the middle mast, then place wood blocks for support.
  - b. Attach slings on both middle mast and inner mast, and lift them with a hoist.
  - c. Remove set bolts from the upper sections of the second lift cylinders, then lift the middle mast and inner mast to separate the second lift cylinder from the middle mast.
  - d. Remove two lift cylinder clamps, dismount the second lift cylinders from the mounting sections at the lower outer mast section. Tilt the cylinders by moving the top sections towards the center of the lift truck. Using a rope, fix the cylinders onto the crossmember.
  - e. Lower the middle mast and inner mast until the mast rollers (outer mast upper roller and middle mast lower roller) can be removed.
  - f. Support the middle mast and inner mast with wood blocks.
  - g. The main rollers of the inner and outer masts can now be removed. It is recommended that before attempting to remove the main rollers, remove the mast strips and shims as they tend to drop easily.
  - h. Adjust shims for the main rollers and mast strips as required.

Unit: mm (in.)	
G	0.1 to 0.5 (0.004 to 0.020)

**Table 12-76.**

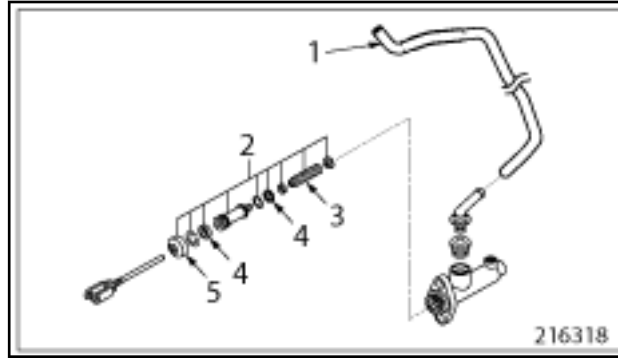
- f. If clearance G is out of specification, adjust it with shims.  
 For adjustment and installation procedures, see "12.20.2.2 INSTALLING MAST ROLLERS."



3. Right-to-left clearance check on outer mast main rollers
  - a. Raise the mast to the top.
  - b. Set a dial indicator on the outer mast with its contact point rested on the inner mast.
  - c. Go over to the opposite side of the mast, and slide the outer mast against the inner mast with a bar. Set the indicator to zero.

Component group	Item	Service	Note
Brake System	Brake System (Reserve tank, Master Cylinder)	Check fluid leaks	In corrosive or abrasive environments, clean, lubricate, and replace more frequently
Cooling System	Radiator Fin	Check / Clean	
	Cooling Fan	Check	When fuel with poor quality is used, check, drain, clean, and replace more frequently
Fuel System	Fuel Hoses, Pipes, and Joints	Check	
Electrical System	Battery	Check specific gravity of electrolyte	Electrolyte level Mot required if battery type is maintenance free
Engine	Engine Idle Speed	Check	
	Spark Plug (K21/25E & K21/25 Gasoline, LPG, Gasoline/LPG Dual Fuel Models)	Check gap	
	External Bolts and Nuts (D04EG)	Tighten	
	Distributor Point, Cap & Rotor(K21/25 Gasoline	Check	
Intake System	Air Cleaner Element	Check / Adjust	
Fuel System	Tar in Vaporizer	Check / Drain	When fuel with poor quality is used, check, drain, clean, and replace more frequently
	Pipe and Joint (LPG)	Check	
Hydraulic System	Hydraulic Tank Return Oil Filter / Wash Strainer	Replace / Clean	
	Hydraulic Control Valve	Check	
	Hydraulic Pump	Check	
Mast and Forks	Lift Chains	Lubricate	In corrosive or abrasive environments, clean, lubricate, and replace more
Front Axle, Rear Axle, and Steering System	Steering Control Valve	Check	
	Steering Axle	Check	
	Steering Knuckle	Check	
Driving System	T/M Clutch	Check	

Table 13-3.



1. **Hose**
  2. **Repair kit**
  3. **Spring**
  4. **Cup**
  5. **Boot**
9. Replace service brake fluid.

Service Hours	Yearly (2000 hrs)
---------------	-------------------

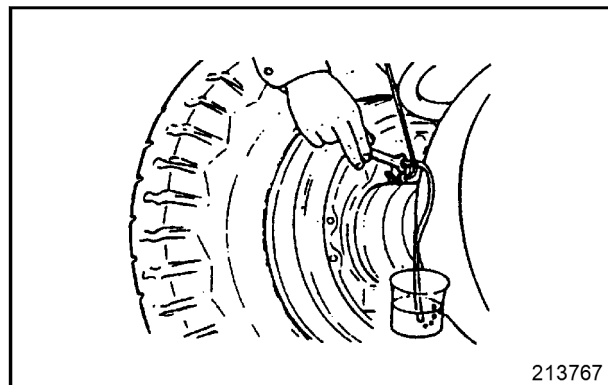
**Table 13-19.**

- Replace brake fluid upon disassembly of the master cylinder or wheel cylinder.
- Perform air bleeding and make sure there is a proper pedal play.

Brake fluid	FMVSS-DOT 3 or DOT4 (SAEJ1703)
-------------	--------------------------------

**Table 13-20.**

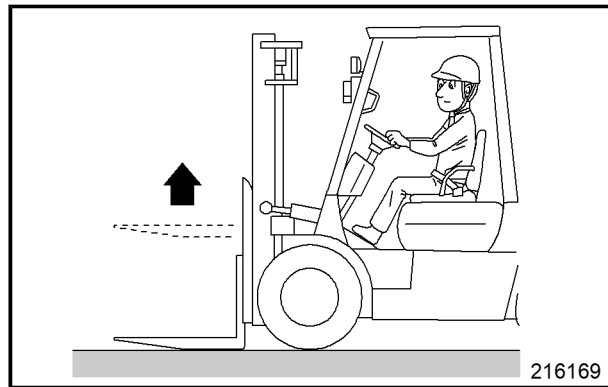
**NOTE:** See [Chapter 9. BRAKE SYSTEM](#)



10. Replace brake wheel cylinder rubber parts.

- a. Park the lift truck on level and hard surface.
- b. Raise the forks high enough to see them from the operator seat.
- c. Apply the parking brake, place the direction lever in the NEUTRAL position, and run the engine at idle speed.
- d. When the operator half rises from the seat, the mast inter lock indicator icon glows in a few seconds.
- e. Check that mast and forks will not move even when the lift or tilt lever is operated.

**NOTE:** See Chapter 4. CONTROLLERS

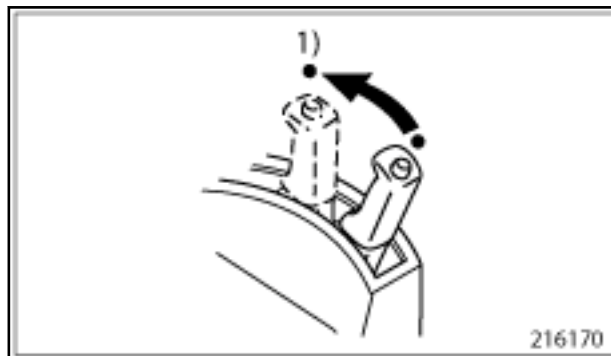


- 10. Check parking brake warning alarm.

Service Hours	Prestart (Daily/10 hrs)
---------------	-------------------------

**Table 13-39.**

**NOTE:** See Chapter 4. CONTROLLERS



- 1) RELEASE

- 11. Check starter.

Service Hours	Every 6 months (1000 hrs)
---------------	---------------------------

**Table 13-40.**



1. DRAIN PLUG

9. Change engine oil filter.

Service Hours	Every 3 months (500 hrs)
---------------	--------------------------

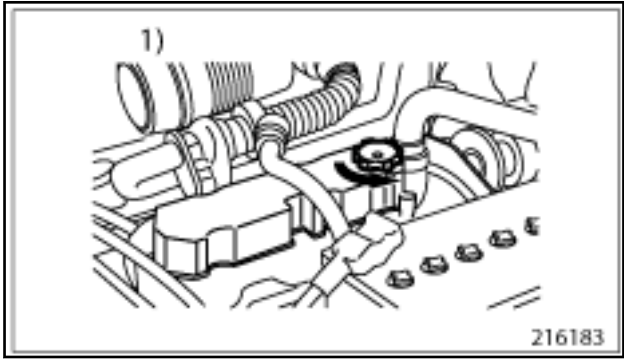
Table 13-53.

- Replace the oil filter at every oil change.
- Add the amount of oil that the filter holds.

NOTE: See the appropriate engine service manual.

Engine oils	Gasoline engine models	API service classification SJ or above
	Diesel engine models (D04EG)	API service classification CJ-4
	Diesel engine models (S4S)	API service classification CF or above

Table 13-54.



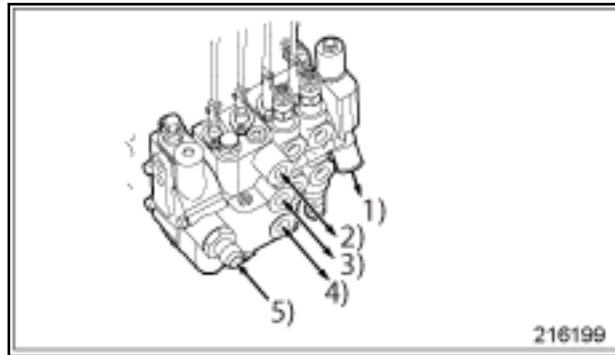
1) (DIESEL)

- Make sure that sufficient space is available for the truck to move around and that no one or no obstacle is around the truck.
1. Check control valve.

Service hours	Yearly (2000 hrs)
---------------	-------------------

**Table 13-71.**

- Check valves for oil leaks.
- Check for the proper operation of valves.



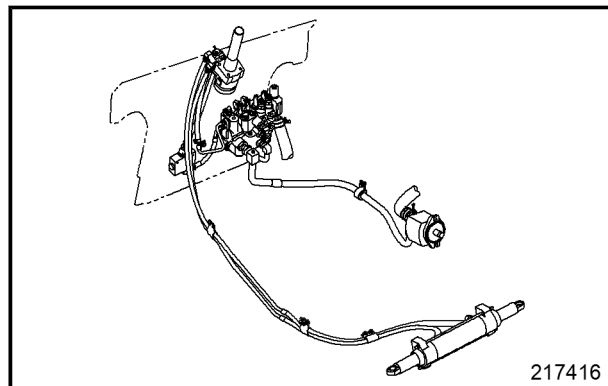
- |                      |                        |
|----------------------|------------------------|
| 1. TO HYDRAULIC TANK | 4. TO LIFT CYLINDER    |
| 2. TO TILT CYLINDER  | 5. FROM HYDRAULIC PUMP |
| 3. TO TILT CYLINDER  |                        |

2. Check hydraulic hose, pipes, and joints.

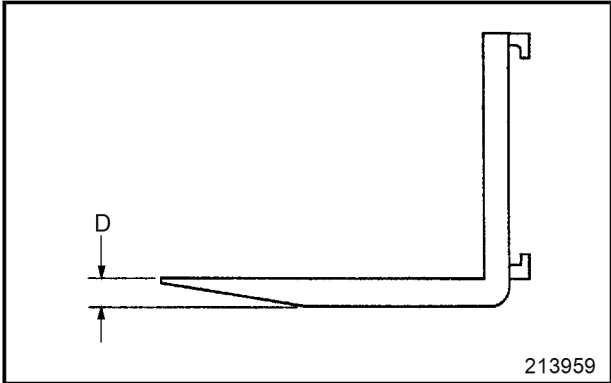
Service hours	Weekly (50 hrs)
---------------	-----------------

**Table 13-72.**

- Check hydraulic hose, pipes and joints for any damage, or oil leak.



3. Check hydraulic oil.



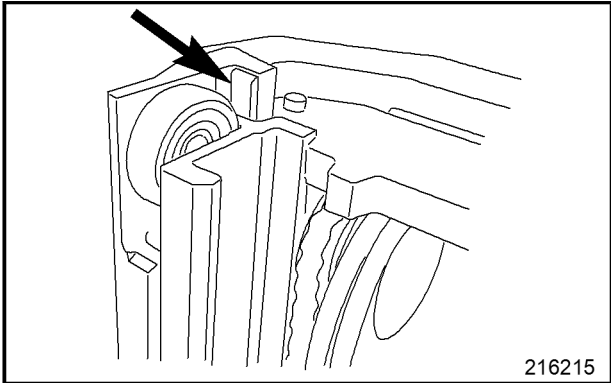
5. Check mast strip sliding surfaces.

Service hours	Prestart (Daily/10 hrs)
---------------	-------------------------

Table 13-88.

- Check the mast strip sliding surface for wear, cracks, rust or chips.

NOTE: See Chapter 12. MAST AND FORKS



6. Check tilt cylinder socket bolts.

Service hours	Prestart (Daily/10 hrs)
---------------	-------------------------

Table 13-89.

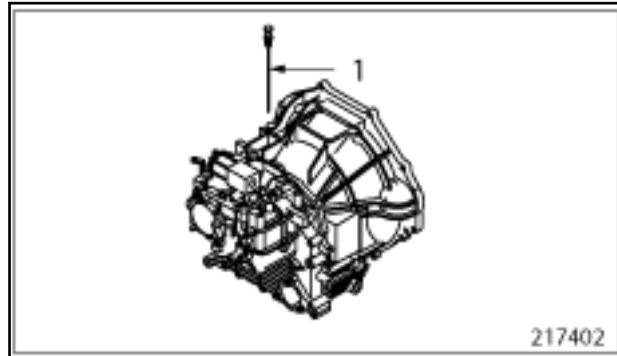
- Check the tilt socket bolts for looseness, chips, rust, and greasing condition.

- b. Warm up the engine with the powershift transmission. Turn the engine OFF after it becomes warm, and measure the oil level between three and five minutes after turning the engine OFF.

**NOTE:** See Chapter 6. POWER SHIFT TRANSMISSION

Powershift transmission oil	Dexron III
-----------------------------	------------

**Table 13-111.**



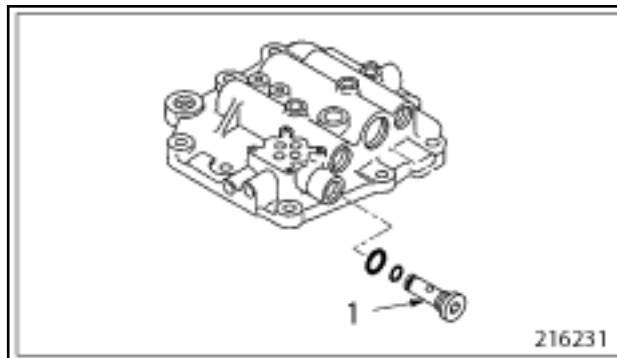
1. OIL LEVEL GAUGE

- 6. Clean last chance filter (T/M control valve).

Service hours	Every 6 months (1000 hrs)
---------------	---------------------------

**Table 13-112.**

- Remove and clean the strainer.



1. STRAINER

- 7. Clean T/M wash strainer.

Service hours	Every 6 months (1000 hrs)
---------------	---------------------------

**Table 13-113.**

## 13.4 PERIODIC REPLACEMENT PARTS

### 13.4.1 PERIODIC REPLACEMENT PARTS

The parts listed below are important for the safe operation of the lift truck, and are specially designated as the parts to be replaced at specified periods. Each service shop must adhere to the replacement schedule given here on all lift trucks brought into its care:

Periodic replacement parts	Service	Period						
		1 month after delivery	3 month (500 hrs)	6 month (1000 hrs)	12 month (2000 hrs)	18 month (3000 hrs)	24 month (4000 hrs)	30 month (6000 hrs)
1 *Rubber parts for brake master cylinder	Replace				X		X	
2 *Rubber parts for brake wheel cylinder	Replace				X		X	
3 *Vaporizer rubber parts for LPG	Replace							X
4 *High pressure hoses	Replace				X		X	
5 *Rubber parts for power cylinder	Replace						X	
6 *Hoses for power steering	Replace						X	
7 *Lift chains	Replace						X	
8 *Fuel hoses	Replace						X	
9 Engine oil filter element	Replace	X	X	X	X		X	
10 Fuel filter element (Diesel)	Replace	X	X	X	X		X	
11 Hydraulic tank return filter	Replace	X		X	X		X	
12 Air cleaner element	Clean	X						
	Replace			X	X		X	
13 Engine coolant	Replace				X		X	
14 LPG fuel filter	Replace				X		X	
15 Spark plug	Replace					X		

**Table 13-127.**

**NOTE:** \*( \* ) indicates important periodic replacement parts.

Items		Truck model		
		2P7000	GP35NM	2PD7000
Steering Wheel Free Play when measured at rim with engine idling, mm (in.)		15 to 30 (0.6 to 1.2)		
Inching Pedal Free Play, mm (in.)		2.5 to 7.5 (0.1 to 0.3)		
Brake Pedal Free Play, mm (in.)		7 (0.3)		
Parking Brake Lever Operating Effort,	N (kgf) [lbf]	230 to 250 (23 to 25) [52 to 56]		
Tire size	Front single	250×15-16PR		
	Front dual	6.00×15-10PR		
	Rear	6.00×10-12PR		
Tire pressure, kPa (kgf/cm <sup>2</sup> ) [psi] (Pneumatic)	Front single	850 (8.5) [120]		
	Front dual	700 (7.0) [100]		
	Rear	900 (9.0) [130]		
Tightening torque for wheel nuts, N·m (kgf·m) [lbf·ft]	Front		378 (38.5) [278.8]	
	Rear	STD (2P)	157 (16) [115.8]	—
		OP (4P)	210 to 256 (21 to 26) [155 to 189]	—
		STD (4P)	—	210 to 256 (21 to 26) [155 to 189]
Lift chain elongation limit mm (in.)/ 20 links		523 (20.6)		

Table 13-136. (Continued)

**NOTE:** Rear tires must have 1050 kg (2315 lb) capacity at 19 km/h (12 mph).

1 ton model

Items		Truck model			
		GP15N	GP18N	GP20CN	
Refill Capacities (approx.), liter (U.S. gal.)	Fuel Tank		46 (12.2)		
	Engine Cooling System – 0.65 liter (1.4 pt) reserve tank included		7.4 (2.0)	6.8 (1.8)	
	Engine Lubrication System	Crankcase	3.5 (0.9)	7.5 (2.0)	3.5 (0.9)
		Oil Filter	0.3 (0.1)	1.0 (0.3)	0.3 (0.1)

Table 13-137.

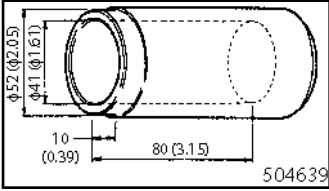
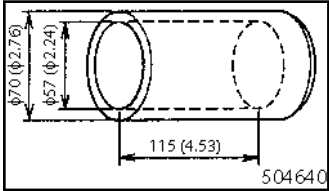
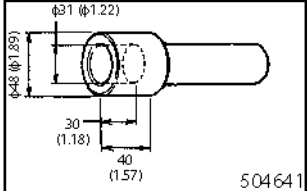
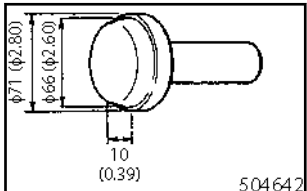
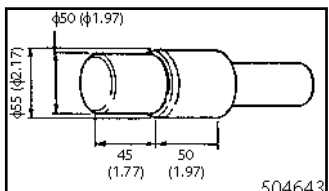
Ref No.	Part number	Part name	Figure	Used for	Truck model		
					1 ton class	2 ton class	3 ton class
22	91268 - 01500	Installer	 <p>1. UNIT: MM (IN.)</p>	Installation of rear axle inner bearing inner race	X	—	—
23	64309 - 40400	Installer	 <p>1. UNIT: MM (IN.)</p>	Installation of rear axle inner bearing inner race	—	X	X
24	91268 - 01400	Installer	 <p>1. UNIT: MM (IN.)</p>	Installation of rear axle outer bearing inner race	X	—	—
25	91468 - 00400	Installer	 <p>1. UNIT: MM (IN.)</p>	Installation of rear axle outer bearing outer race	—	X	X
26	91468 - 00500	Installer	 <p>1. UNIT: MM (IN.)</p>	Press-fitting of rear axle pivot bushing	—	X	X

Table 13-147. (Continued)

## Chapter 15 HOW TO READ CIRCUIT DIAGRAMS

### 15.1 DESCRIPTION OF CIRCUIT DIAGRAMS

#### 15.1.1 CIRCUIT DIAGRAMS

The circuit diagrams consist of the schematic diagrams and connector diagrams.

All circuits including the power supply and ground are divided into the power circuit, GND circuit and system circuits.

##### **Power circuit diagram**

The power circuit diagram indicates the power circuit including the battery, fuse, ignition switch, etc.

##### **GND circuit diagram**

The GND circuit diagram indicates the circuits from each electric component to the body ground or from each component to the battery negative terminal.

##### **System circuit diagrams**

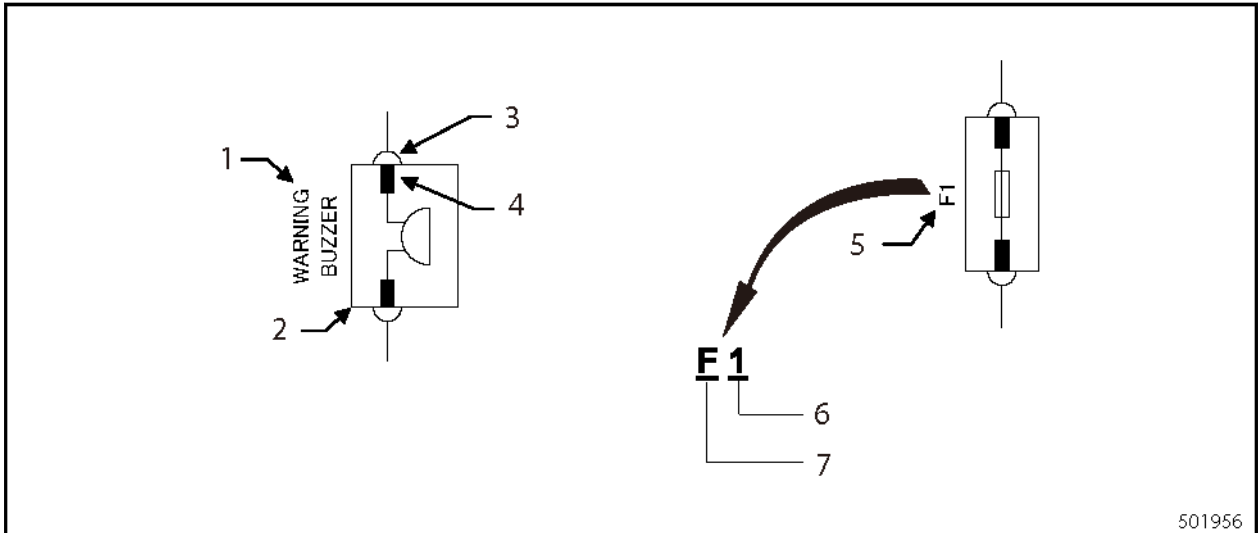
The system circuit diagrams indicate the circuits of each system from fuse to GND (earth) excluding the above power supply and GND circuit portions.

#### 15.1.2 CONNECTOR DIAGRAMS

The connector shapes, terminal shapes and terminal arrangements of all connectors in the circuit diagrams are indicated.

- (2) The items listed under the item category symbol have a specific symbol (equipment number) for classification of items and identification of identical items.

**Equipment number system**



**Figure 15-5.**

- |                                   |                                          |
|-----------------------------------|------------------------------------------|
| 1. EQUIPMENT NAME                 | 5. EQUIPMENT NUMBER                      |
| 2. BOX                            | 6. CLASSIFICATION NUMBER (SERIAL NUMBER) |
| 3. CONNECTOR FOR HARNESS          | 7. ITEM CATEGORY SYMBOL                  |
| 4. CONNECTOR BELONGS TO EQUIPMENT |                                          |

**Item category symbol**

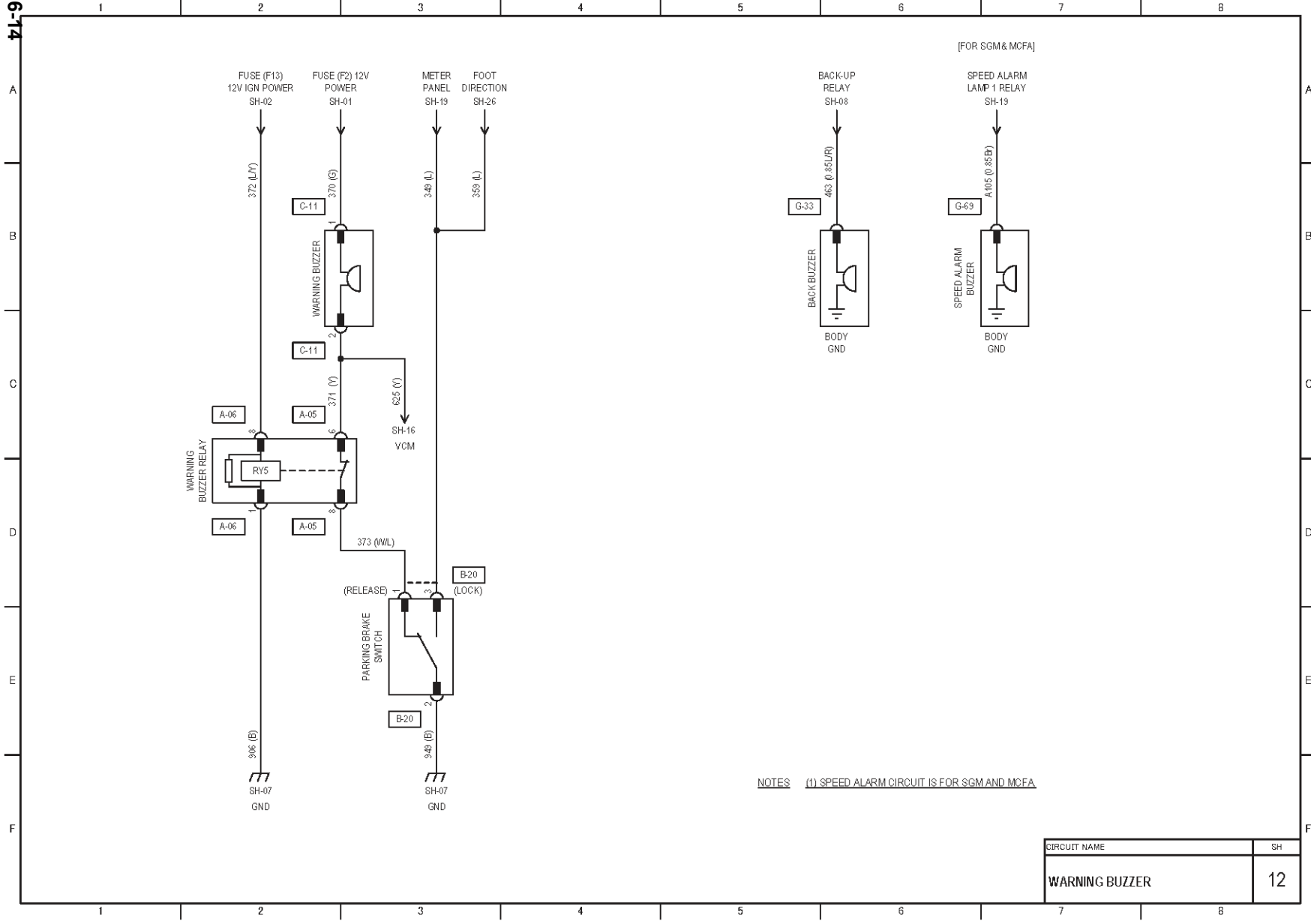
Symbol	Item	Symbol	Item
F	Fuse	MC	Contactora
SBF	Slow-blow fuse	R	Resistor
FLW	Fusible link	C	Capacitor
RY	Relay	D	Diode

**Table 15-16.**

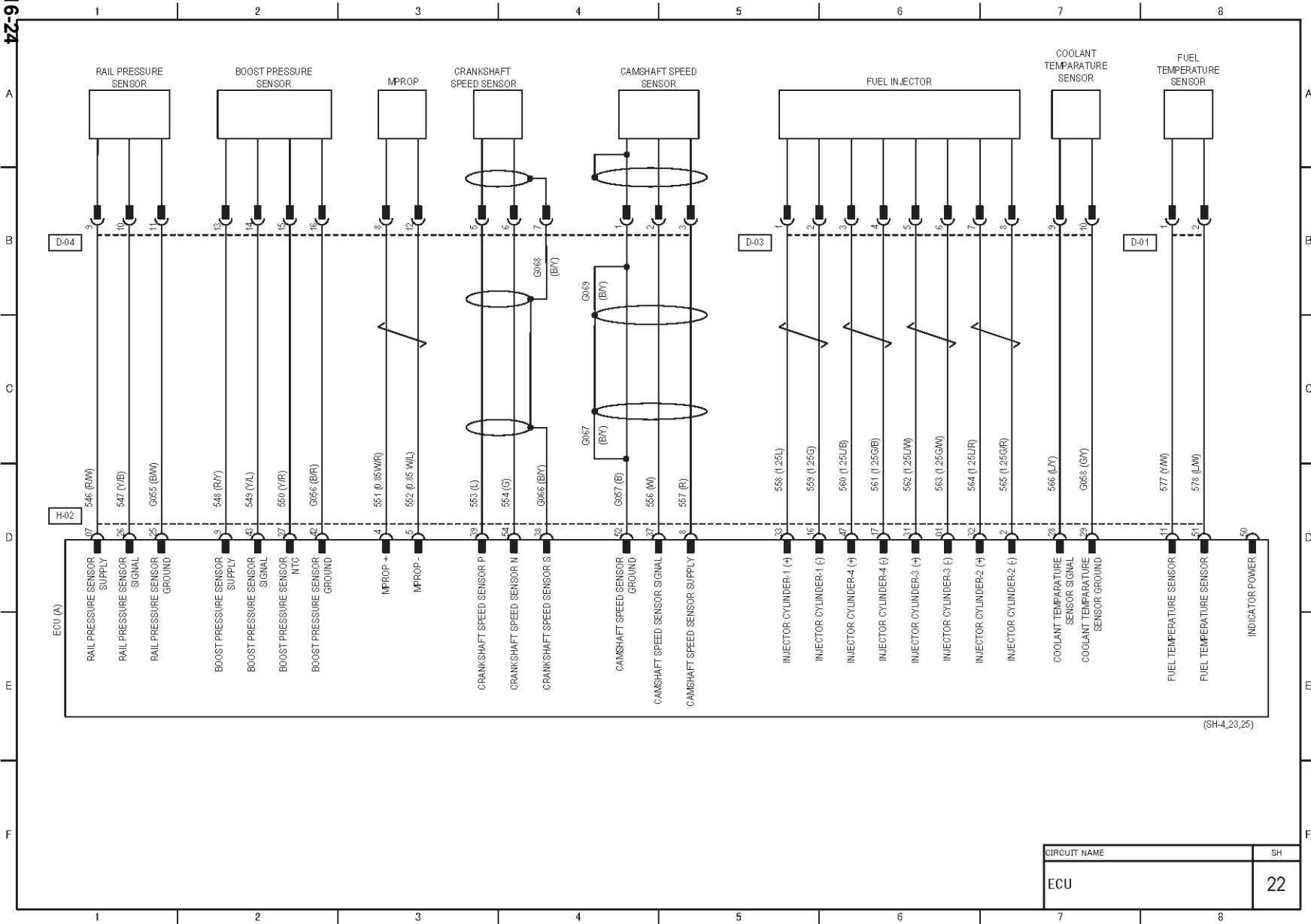
**15.2.6 RELAY CONTACTOR AND COIL**

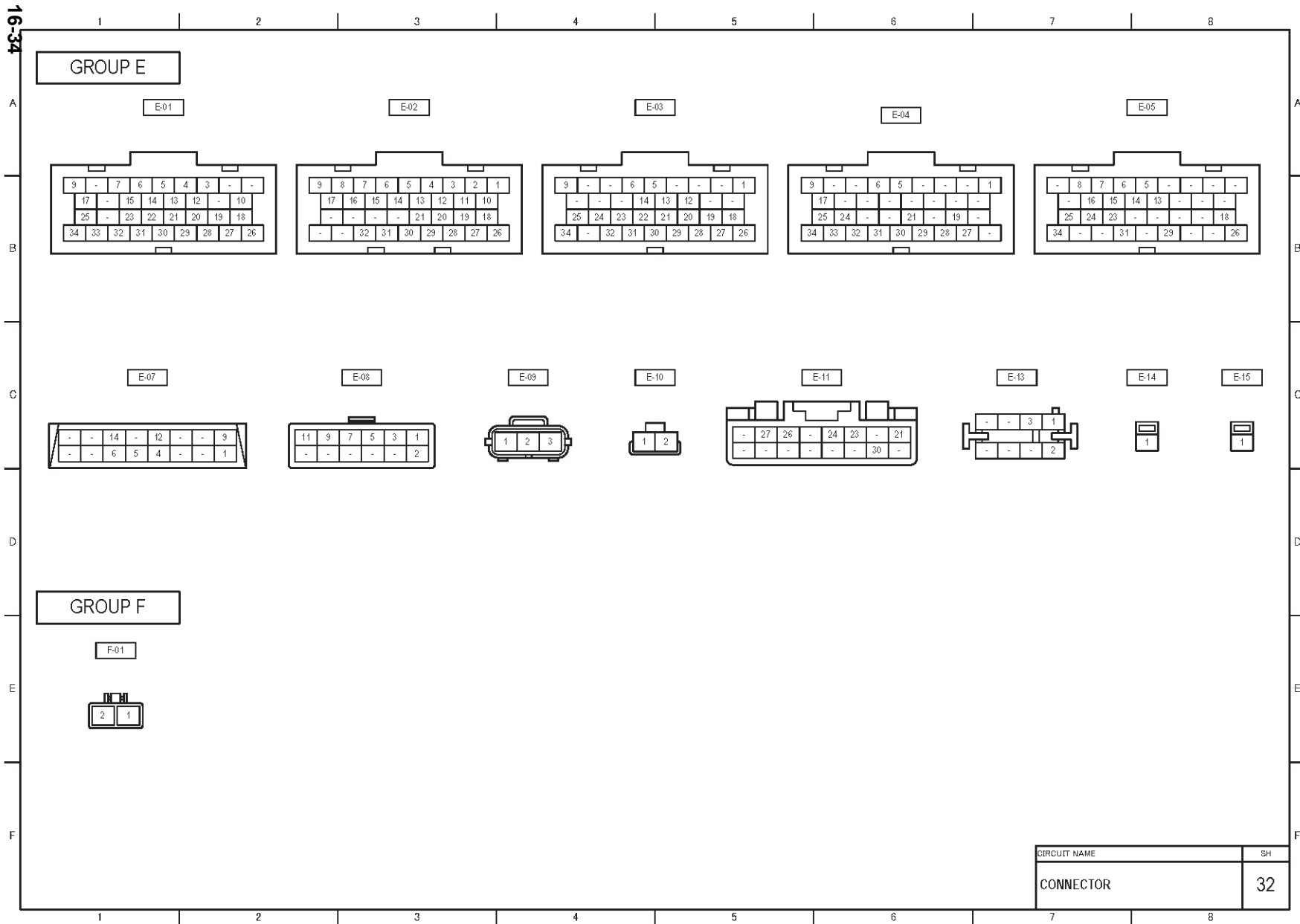
- (1) For the relay contactor, the sheet symbol in which its coil is represented is provided so that you can find its coil easily. However, when the coil is represented in the same sheet, the sheet symbol is omitted.





CIRCUIT NAME	SH
WARNING BUZZER	12





CLICK HERE TO **DOWNLOAD** THE COMPLETE MANUAL

- Thank you very much for reading the preview of the manual.
- You can download the complete manual from: [www.heydownloads.com](http://www.heydownloads.com) by clicking the link below



- Please note: If there is no response to CLICKING the link, please download this PDF first and then click on it.

CLICK HERE TO **DOWNLOAD** THE COMPLETE MANUAL