



Operation & Maintenance Manual

MC/FC

GP15N	T25C-55001-up	DP15ND	T16D-54001-up	DP20NTS	T18C-20001-up
GP15ZN	T34-52001-up	DP15NT	T16D-54001-up	DP20N	T18C-40001-up
GP18N	T25C-75001-up	DP15NDS	T16D-54001-up	DP25ND	T18C-70001-up
GP18ZN	T34-72001-up	DP15NTS	T16D-54001-up	DP25NT	T18C-70001-up
GP20CN	T34-22001-up	DP15N	T16D-64001-up	DP25NDS	T18C-70001-up
GP20N	T17D-10001-up	DP18ND	T16D-74001-up	DP25NTS	T18C-70001-up
GP20ZN	T35-10001-up	DP18NT	T16D-74001-up	DP25N	T18C-90001-up
GP25N	T17D-60001-up	DP18NDS	T16D-74001-up	DP30ND	T14E-10001-up
GP25ZN	T35-60001-up	DP18NTS	T16D-74001-up	DP30NT	T14E-10001-up
GP30N	T13F-40001-up	DP18N	T16D-84001-up	DP30NDS	T14E-10001-up
GP35N	T13F-60001-up	DP20CND	T16D-24001-up	DP30NTS	T14E-10001-up
GPE15N	T34-00001/19001-up	DP20CNT	T16D-24001-up	DP30N	T14E-20001-up
GPE18N	T34-40001/49001-up	DP20CNDS	T16D-24001-up	DP35ND	T14E-80001-up
GPE20CN	T34-30001/39001-up	DP20CNTS	T16D-24001-up	DP35NT	T14E-80001-up
GPE20N	T17D-20001/38001-up	DP20CN	T16D-28001-up	DP35NDS	T14E-80001-up
GPE20ZN	T35-20001/38001-up	DP20ND	T18C-20001-up	DP35NTS	T14E-80001-up
GPE25N	T17D-70001/88001-up	DP20NT	T18C-20001-up	DP35N	T14E-90001-up
GPE25ZN	T35-70001/88001-up	DP20NDS	T18C-20001-up		
GPE30N	T13F-10001/20001-up				
GPE35N	T13F-80001/90001-up				

Original Instructions

Keep this manual in your lift truck as a ready reference

99710-36120

CLICK HERE TO **DOWNLOAD** THE COMPLETE MANUAL

- Thank you very much for reading the preview of the manual.
- You can download the complete manual from: www.heydownloads.com by clicking the link below



- Please note: If there is no response to CLICKING the link, please download this PDF first and then click on it.

CLICK HERE TO **DOWNLOAD** THE COMPLETE MANUAL

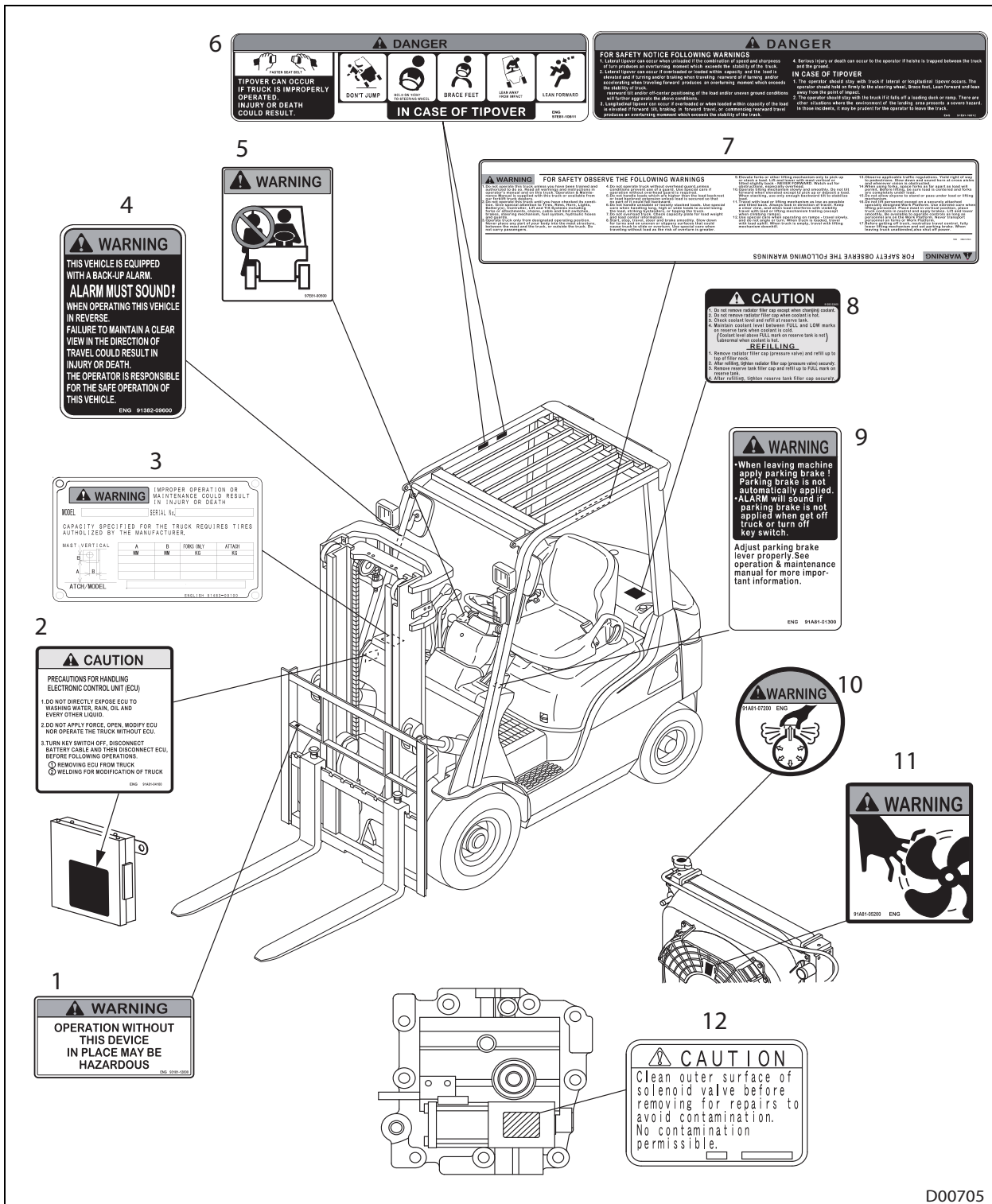

D00705

1. With Load Backrest Extension decal
2. Precautions for Handling E.C.U. decal
3. Capacity Plate
4. Back-up Alarm decal
5. No Riders Warning decal
6. Survive in a Tipover decal
7. Operation Warning decal
8. Engine Coolant decal
9. Parking Brake Adjustment decal
10. Radiator Cap Warning decal
11. No Access with Engine Running decal
12. No Contamination Permissible decal

⚠ CAUTION

When handling Engine Control Module (ECM), Vehicle Control Module (VCM) and Diesel engine control module (DCM)!

- DO NOT allow washing water, rain, oil or any other liquid on the ECM/VCM/DCM.
- DO NOT apply force, open or modify the ECM/VCM/DCM or operate the lift truck without the ECM/VCM/DCM.
- Turn the key switch to the ○ (OFF) position. Disconnect battery cables and ECM/VCM/DCM connections before the following operations:
 - Removing ECM/VCM/DCM from the lift truck.
 - Factory-approved welding.

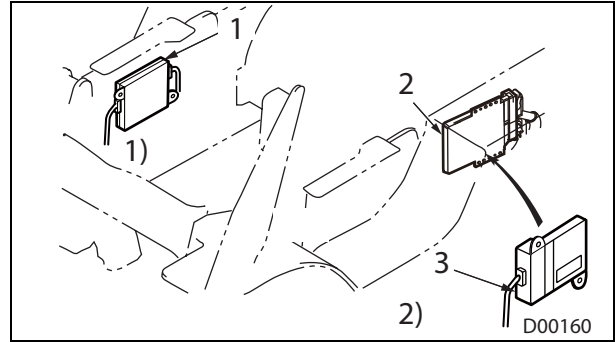

- 1. VCM (Vehicle control module) 1) Inside the right step
- 2. ECM (Engine control module) 2) Under the battery
- 3. DCM (Diesel engine control module)

⚠ WARNING

DO NOT operate the lift truck if you are pregnant or have suffered an abdominal disease or injury.

⚠ WARNING

DO NOT remove the overhead guard!

The overhead guard is intended to offer protection from the impact of small packages, boxes, bagged material, etc., representative of the job application, but not to withstand the impact of a falling capacity load.

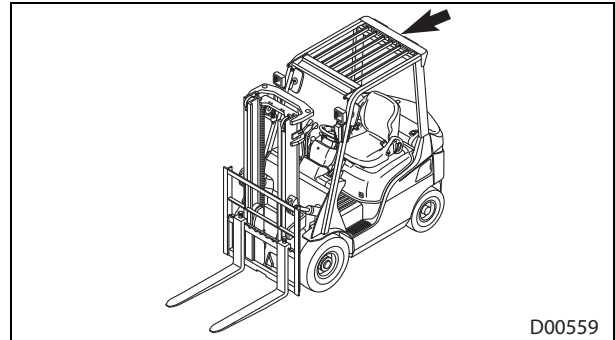

⚠ WARNING

DO NOT operate the lift truck under the influence of drugs or alcohol!

Always stay healthy on the job. Operators of lift trucks must be qualified as to visual, auditory, physical, and mental ability to operate the lift truck safely.

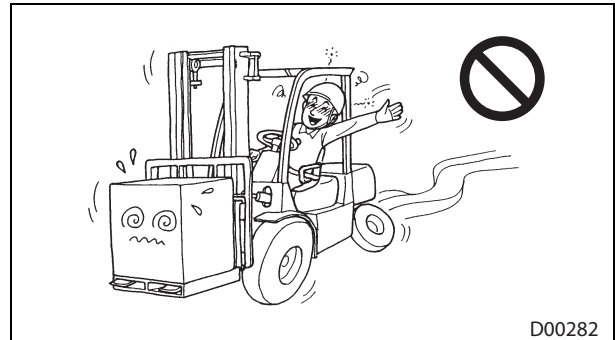

⚠ WARNING**Handle only stable and safely arranged loads!**

If a load is unstable, it could easily shift and fall on someone.

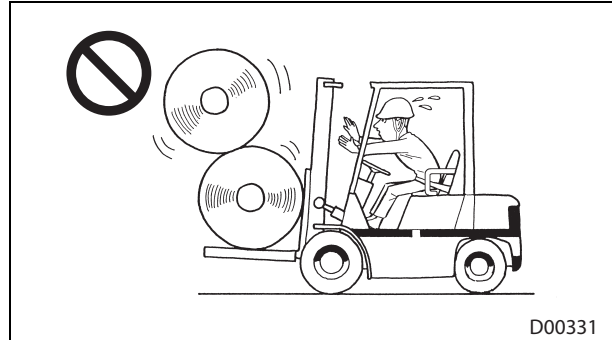

D00331

⚠ WARNING**Stay clear of pinch points!**

Keep all parts of your body away from moving parts such as the mast, carriage and attachments. DO NOT place any part of your body between the overhead guard and the mast. If the mast moves unexpectedly, you could get caught between the mast and overhead guard and a serious accident could occur.

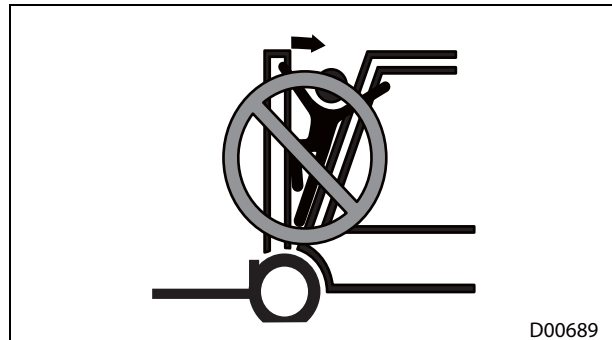

D00689

⚠ WARNING**DO NOT allow unloading from raised loads!**

Failure to follow these rules could cause serious injury.

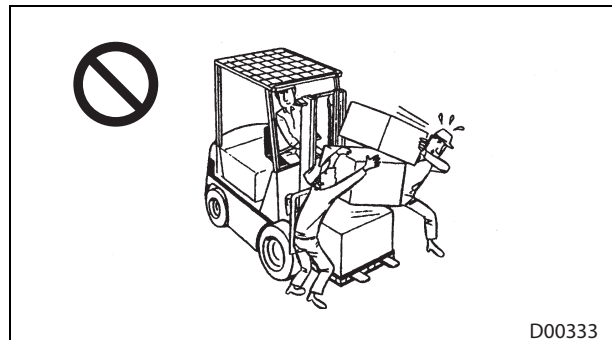

D00333

► Inching Pedal

An operator can move the lift truck slowly by pressing the inching pedal to lower the traveling speed while maintaining engine speed.



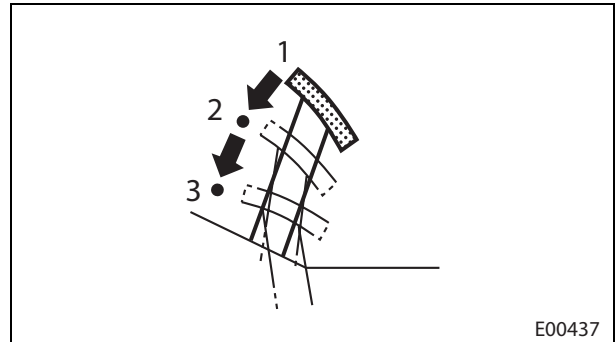



Full application of the pedal puts the transmission in neutral and applies the service brake.



- 1. Released
- 2. Clutch disengaged
- 3. Brake applied

Symbols

The symbols shown on the main display are listed below:

Symbol	Name	Condition
	Brake Fluid Level Warning Lamp	When brake fluid level is low (Option)
	Fuel Filter Drain Warning Lamp	When fuel filter needs to be drained (Diesel model)
	Coolant Level Warning Lamp	When coolant level is low (Option)
	Clogged Air Cleaner Element Warning Lamp	When air cleaner element is clogged (Option)
	Low Fuel Level Warning Lamp	When fuel level is low (On LPG/Gasoline dual models, when gasoline level is low.)
	LPG Level Warning Lamp	When LPG level is low (LPG model) (Option)

► **Optional Functions**

The following optional functions are available.

- password authentication
- service interval display
- over speed warning
- load meter display
- over load warning
- exterior alarm
- speed restrictions

Note: Installation of special devices is required on the lift truck for the load meter display, the over load warning and the exterior alarm.

To use these options, function settings are required. Consult your authorized Cat Lift Truck dealer for details.

Password authentication

This function prevents an unauthorized person from operating the lift truck. To operate the lift truck, you need to enter the registered four-digit password.

Inputting a password

Turn the key switch to the I (ON) position.

When the password input screen is displayed after brand logo screen, enter the registered four-digit password.

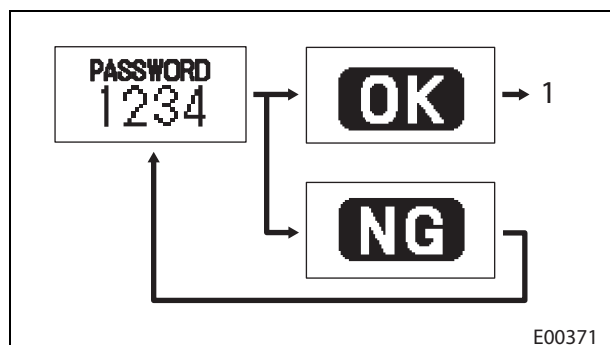

E00371

1. To standard screen

► **Tilt Lever**

Tilt speed is controlled by the speed of the engine (the position of the accelerator pedal) and the position of the tilt lever. The lever will return to the neutral position when released.

To deactivate the mast interlock system, the operator sits on the operator seat while the key switch is in the I (ON) position with the engine running, and then operate the tilt lever.

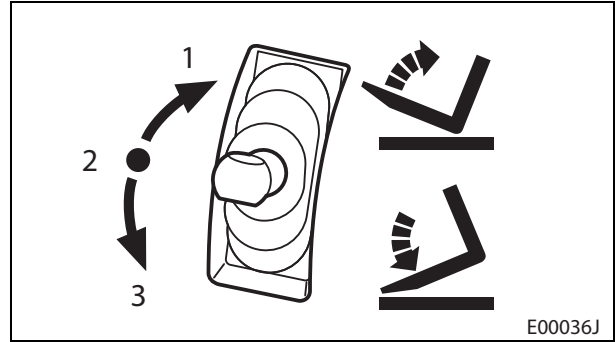

1. Backward
2. Neutral
3. Forward

► **Attachment Lever A/B (Optional)**

To deactivate the mast interlock system, the operator sits on the operator seat while the key switch is in the I (ON) position with engine running, and then operate the attachment lever.

Attachment lever A (optional)

This lever is for operating the third attachment.

Attachment lever B (optional)

This lever is for operating the fourth attachment.

► **Selector Switch Between Forth and Fifth Attachment**

For operation of the fifth attachment, operate the attachment lever B while pressing this switch.

► **Lowering Speed Selector Switch (Optional)**

Do not touch the lift/tilt or attachment lever when turning this switch ON or OFF.

Slow

This position allows you to lower the forks at 70% of the normal or rated speed. Use this switch until you feel sure of what is going to happen when you move the lift control, or when you handle fragile loads.

Normal

This position allows you to lower the forks at the normal speed.

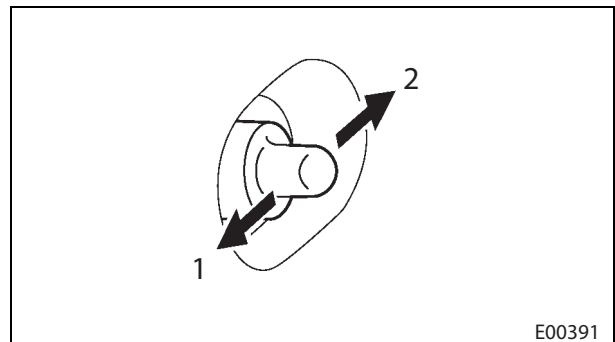

1. Slow
2. Normal

■ HOW TO AVOID A TIPOVER; HOW TO SURVIVE ONE

◆ Know What Lift Truck Stability Is

Counterbalanced lift truck design is based on the balance of two weights on opposite sides of a fulcrum (the front axle).

The load on the forks must be balanced by the weight of the lift truck. The location of the center of gravity of both the lift truck and the load is also a factor.

This basic principle is used for picking up a load. The ability of the lift truck to handle a load is discussed in terms of center of gravity and both forward and sideways stabilities.

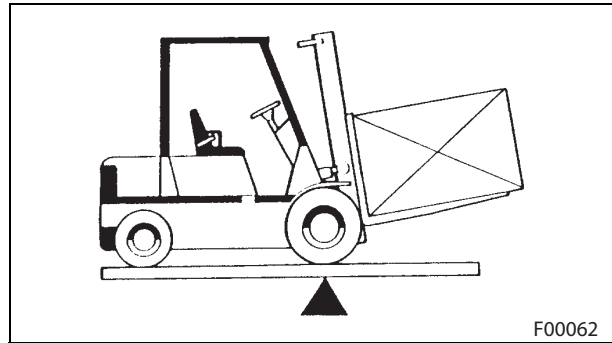

◆ Center of Gravity (CG)

Center of Gravity (CG) is defined as the point of an object where its weight is evenly distributed.

If the object is uniform, its geometric center will be the same as its CG. If it is not uniform, the CG could be a point on either side of the normal geometric center.

When the lift truck picks up a load, the lift truck and load have a new, combined CG.

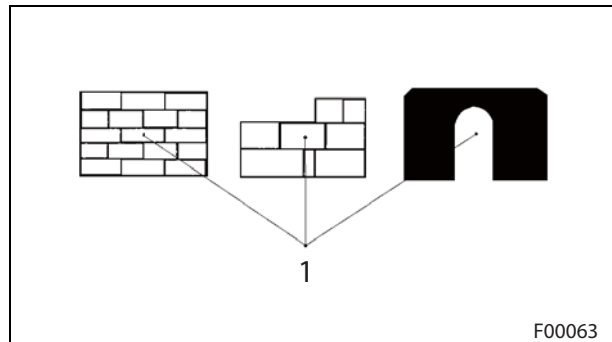

1. CG

◆ Stability and Center of Gravity

The stability of the lift truck is determined by the location of its CG, or if the lift truck is loaded, the combined CG.

The lift truck has moving parts and, therefore, has a CG that moves. The CG moves forward or backward as the mast is tilted forward or backward. The CG moves up or down as the mast moves up or down.

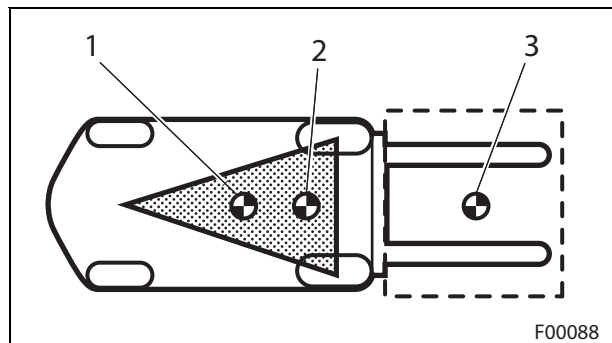

1. CG truck

2. Combined CG

3. CG load

The CG and the stability of the loaded lift truck are affected by a number of factors such as:

- The size, weight, shape and position of the load.
- The height of the lifted load.
- The angle of forward or backward tilt.
- Dynamic forces created when the lift truck is accelerated, braked or turned.
- Condition and grade of surfaces on which the lift truck is operated.

⚠ WARNING

Before starting, always adjust the operator seat at a proper place so that you can press all the pedals fully down. Seat adjustment while driving could lead to accidents.

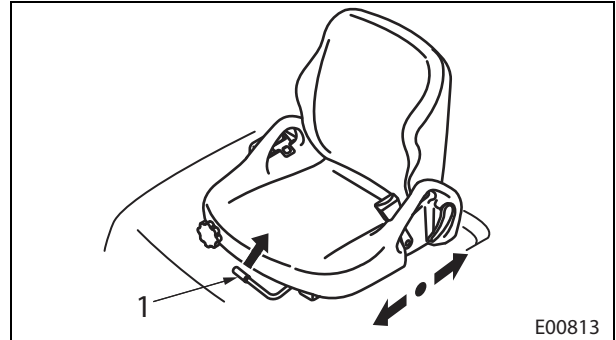

1. Lever

Your lift truck has an operator presence switch installed in the operator seat.

► Starting Engine

- (1) Press the brake pedal.
- (2) Apply the parking brake lever.
- (3) Make sure the direction lever is in the NEUTRAL position.
- (4) The engine will not start unless the direction lever is in the neutral position.
- (5) If the engine stalls, place the direction lever in the NEUTRAL position, turn the key switch to the ○ (OFF) position, and turn it to the Ⓢ (START) position to start the engine.

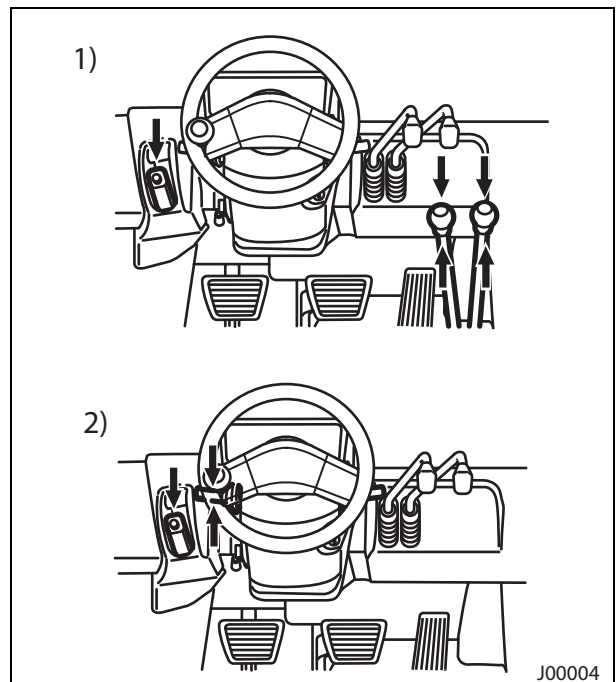

1. Manual

2. Powershift

FC model

You are unable to move the mast and attachments unless you are seated.

MC model

The mast interlock will work only for the lift and tilt levers.

Attachments can be moved regardless of whether the mast interlock function is operating or not. Therefore, when the attachment lever is operated, some of the attachments will move, even though the engine is not running or the key switch is in the ○(OFF) position, as a result of the handling load or of its own weight.

The starting mechanism in lift trucks with powershift transmission is disabled until the operator is seated. When the key switch is in the I (ON) position, the mast interlock indicator lamp and driving interlock indicator lamp in the meter panel flash unless an operator sits on the operator seat properly. In addition, the seat belt warning lamp glows when the seat belt is not worn or when it is not inserted into the seat belt buckle properly.

◆ Stopping Lift Truck

⚠ WARNING

If brake linings have become wet after cleaning the lift truck or after driving through a large area of water, stopping distance could be increased. In this case, gently apply brakes several times while driving slowly in a safe area until linings have dried out and normal braking action is restored.

⚠ WARNING

Avoid sudden stops. This could cause the load to fall off the forks or the lift truck to tip over.

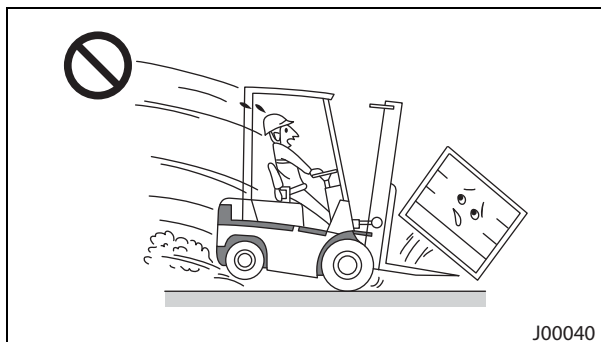

► MANUAL

- (1) Release the accelerator pedal.

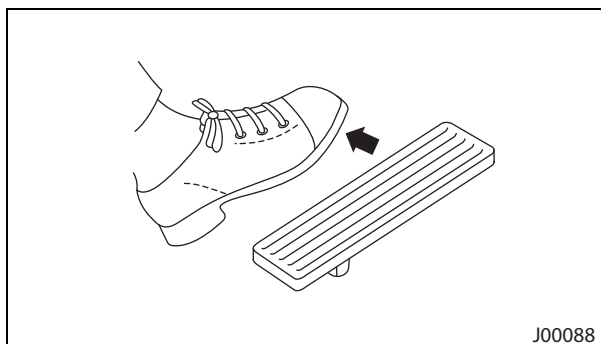

- (2) Pressed the brake pedal and, just before the lift truck stops, press the clutch pedal.

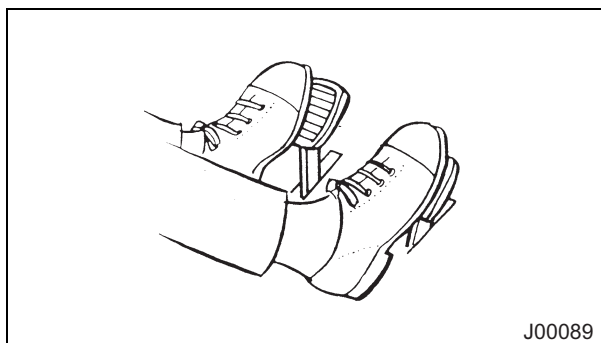

- (3) After the lift truck has been stopped, pull the parking brake lever all the way back.
- (4) Place the direction lever and gearshift lever in NEUTRAL position.

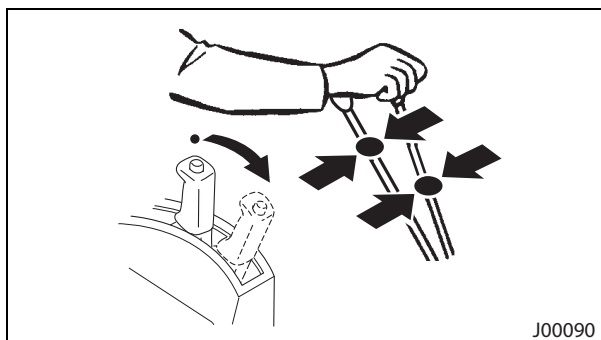

⚠ WARNING

DO NOT pick up an off-center load. Make sure the weight of the load is centered between the forks.

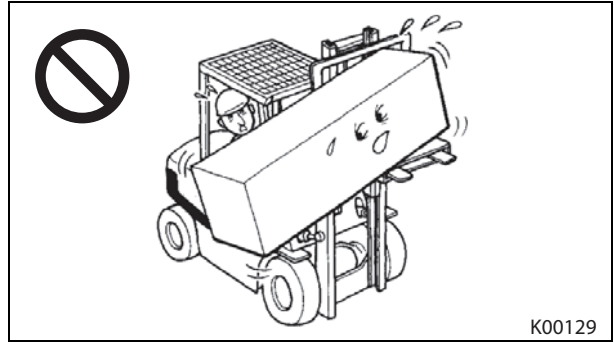

- (9) Look around to make sure your drive area is clear.
- (10) Honk horn.
- (11) Place the direction lever in the BACKWARD position and change the direction to the work place.
- (12) Place the direction lever in the FORWARD position and move the lift truck into the work place.

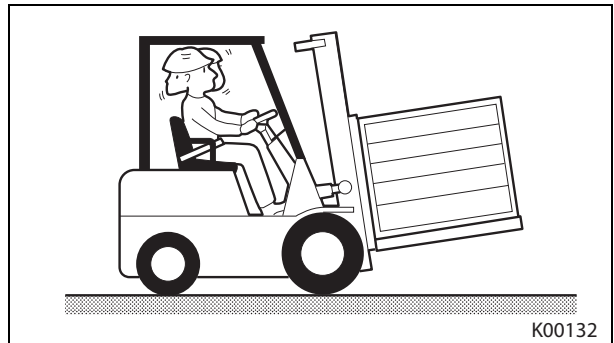

⚠ WARNING

If the load blocks your view, or when you travel down a grade with the load, drive in REVERSE. Always look in the direction of travel.

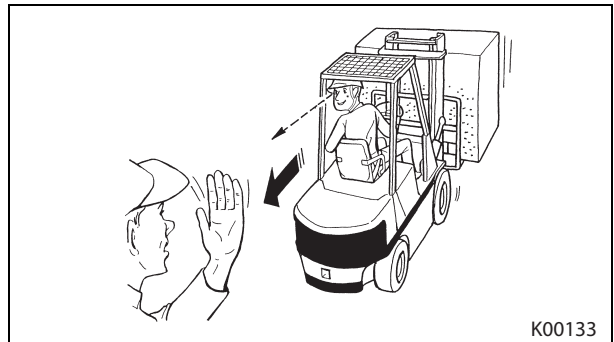

⚠ WARNING

Stop raising the lift truck when the tire clears the ground.
DO NOT raise the lift truck more than necessary.



⚠ WARNING

DO NOT place any part of your body under the lift truck until the lift truck is securely supported with jack stands after jacking it up.

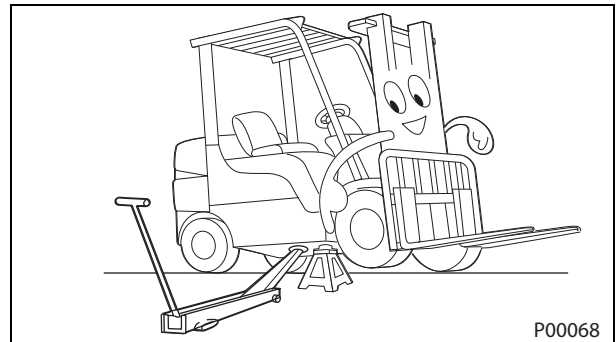

► Before Changing Tires

- (1) Park the lift truck on level ground.
- (2) Lower the forks until the fork tips touch the ground.
- (3) Apply the parking brake.
- (4) Place the direction lever in the NEUTRAL position.
- (5) Stop the engine.



- (6) Prepare tools, jack and wheel blocks.
- (7) Block the wheel diagonally opposite to a raised wheel.

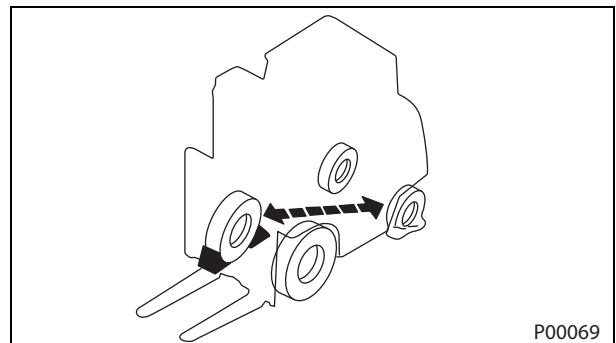

Models	Jack capacities
1 ton	3 tons (6700 lbf), minimum
2 to 3 ton	5 tons (12000 lbf), minimum

◆ If the Mast and Attachments Malfunction (FC Model)

Push down on the emergency mast stop button to stop the mast and attachments.

⚠ WARNING

- If you see the mast or attachment malfunctioning, push down on the emergency mast stop button. Contact your authorized Cat Lift Truck dealer immediately.
- DO NOT attempt to return the emergency mast stop button to the OPERATE position for operating the lift truck before an authorized mechanic arrives on the scene.

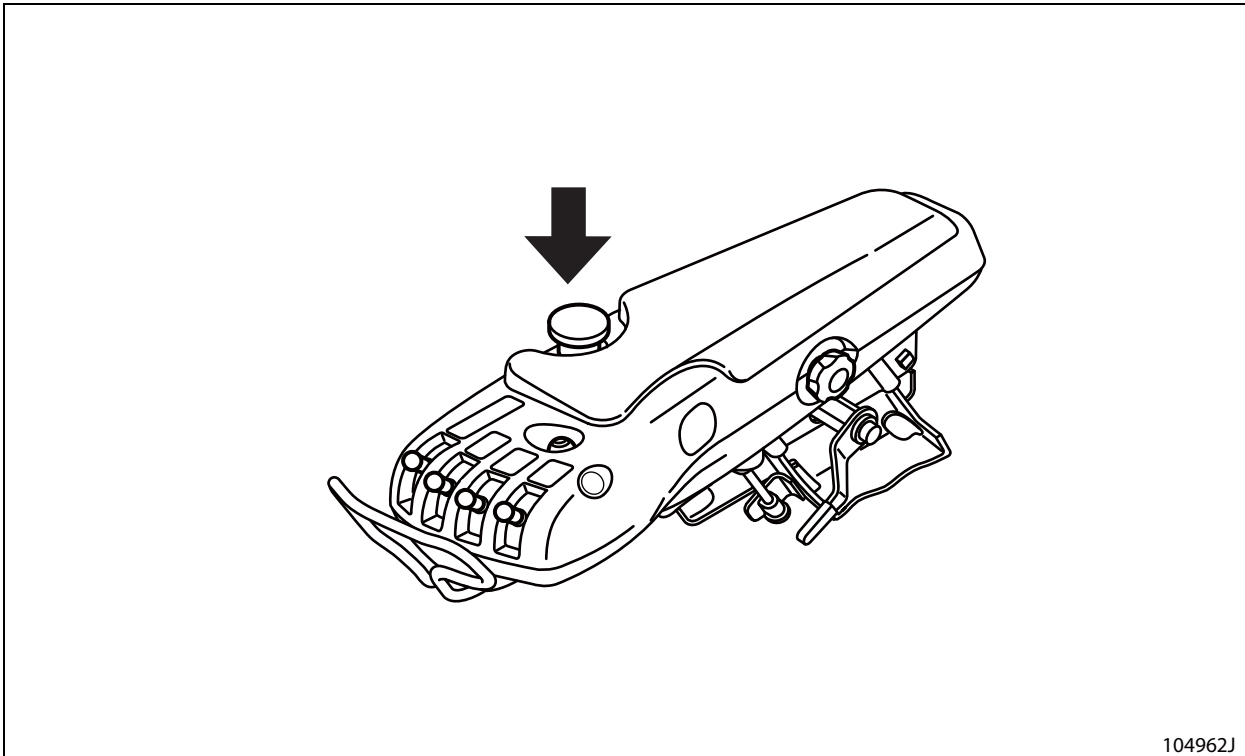

104962J

Push down on the emergency mast stop button, and then take the following safety measures.

- (1) Move the lift truck to a safe area.
- (2) Return the direction lever to the NEUTRAL position.
- (3) Apply the parking brake.
- (4) Turn the key switch to the ○ (OFF) position.
- (5) Attach a "DO NOT ENTER" or similar warning tag to the mast or fork of the lift truck in order to let other people know your lift truck is broken.
- (6) Contact your authorized Cat Lift Truck dealer immediately.

► Tires and Rims

Check

⚠ WARNING

- Make sure the replacement tire is of the same size, type and load range. See manufacturer name plate located on the front of the lift truck for correct tire size.
- When changing tires, change them in sets, even if only one of the tires is damaged. If new and used tires are used on the same axle, tilting of the mast and rapid tire wear will result.
- Use only tires recommended by the manufacturer.

⚠ CAUTION

The lift truck tires are highly inflated. Even slight damage to the tire or rim may cause a blowout of the tire.

How to check

- Are all the tires free of cuts, gouges or foreign objects?
- Are all the rims free of distortion or cracks?
- Is the tread groove depth more than 5 mm (0.2 in.) when checked with a tire depth gauge?
If not, change the tire.

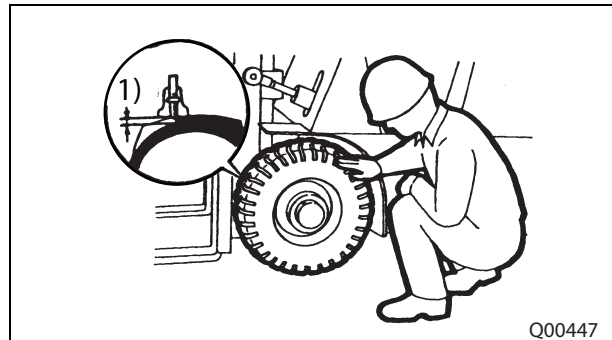

1) Limit: 5 mm (0.2 in.)

Note:

- For changing tires, refer to 10-1 "Changing Tires"
- Contact your authorized Cat Lift Truck dealer when requesting to change tires.

MAINTENANCE

► Electrical Wires

Check

Visually check all the electrical wires for any damage.

- Are there any loose connections at joints?
- Are there any loose clamps?

► Brake Hoses, Pipes and Joints

Check

- Hoses, pipes and joints should be checked for damage, cracks and brake fluid leaks.

► Hydraulic Oil

Check Oil Level

⚠ WARNING

- Hot oil and components could cause personal injury. DO NOT allow hot oil or components to contact your skin.
- Remove the hydraulic tank filler cap only after the engine has been stopped and the cap is cool enough to remove with your bare hand.
- Remove the hydraulic tank filler cap slowly to relieve pressure.

Preparation

- (1) Operate the lift truck for a few minutes to warm the oil.
- (2) Park the lift truck on level ground.
- (3) Lower the forks until the fork tips touch the ground.
- (4) Tilt the mast back.
- (5) Apply the parking brake.
- (6) Place the direction lever in the NEUTRAL position.

How to check oil level

- (1) Remove the hydraulic tank filler cap by turning it counterclockwise.
- (2) Add oil needed to raise it to the correct level range on the dip stick.

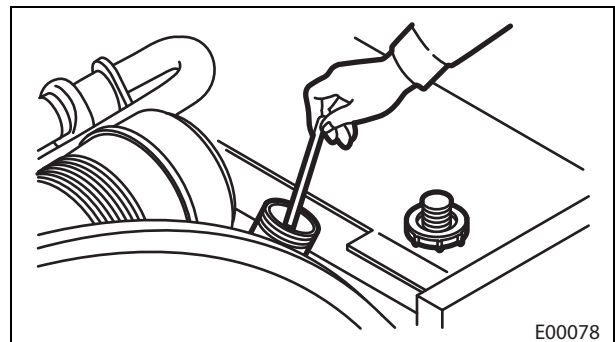

- (3) Put the hydraulic tank filler cap back on.
- (4) Check for oil leaks.
- (5) Close and secure the engine hood.

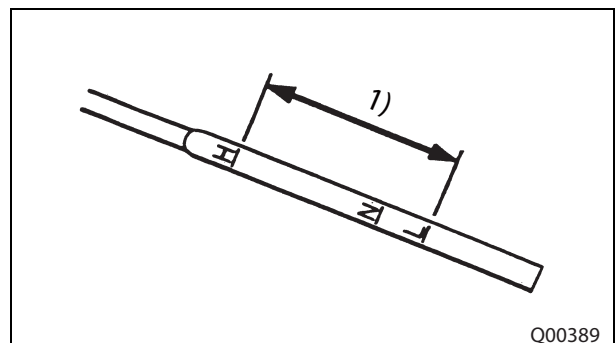

1) Correct level range

► **Starter**

Check

Does the starter crank the engine?

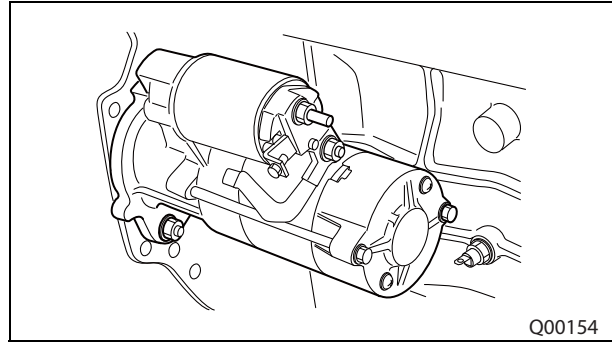

► **Cylinder Head Bolt & Manifold Nut**

Check

Check all the cylinder head bolts and manifold nuts for tightness with torque wrench.

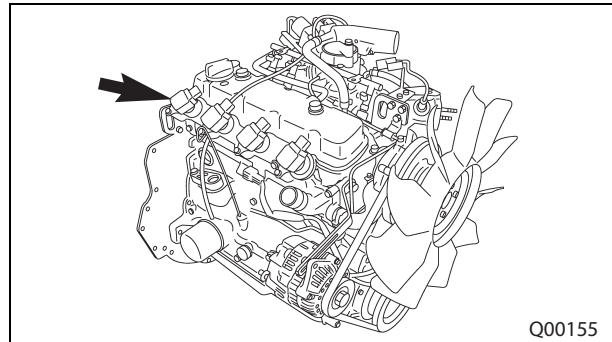

► **Intake & Exhaust Valve**

Check Clearance

Check the intake & exhaust valve clearances with a feeler gauge.

- (1) Adjust the clearance by turning the screw in either direction for the appropriate thickness (0.25 mm [0.0098 in.]).
- (2) After adjusting the clearance, tighten the lock nut firmly, and inspect the clearance again.

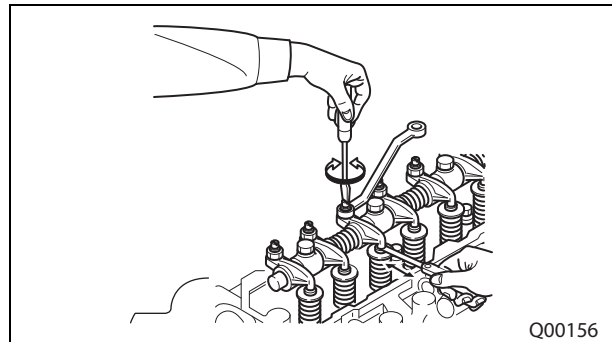

► **Engine Oil**

Change Oil and Filter

- Replace oil and filter.

Refer to "Engine Oil" under "Every 500 Service Hours or 3 Months, Whichever Comes First. "

► **Bolts and Nuts (Frame & Chassis)**

Check

Bolts and nuts of frame and chassis should be retightened.

► **Injection Nozzle (LP-Gas Engine)**

Check

Check the injection nozzle for any oil leakage or damage.

MAINTENANCE

► Fuel Filter (Diesel)

Change

⚠ WARNING

- Fuel leaked or spilled onto hot surfaces or electrical components could cause a fire.
- Clean up any fuel spillage.
- Know the location of all emergency devices (such as fire extinguisher, first aid kit, etc.) and how to use them.
- Disconnect the battery when changing fuel filters.

Note: Park the lift truck in an authorized refueling area with the forks lowered until the fork tips touch the floor or ground, parking brake applied, direction lever in the neutral position, engine stopped and the wheels blocked. The engine must be cooled down.

- (1) Raise the engine hood.
- (2) Remove the filter.
- (3) Use filter wrench to remove filter element.
- (4) Clean sealing surface of filter base.
- (5) Apply a light coat of engine oil to the gasket of the new filter element.
- (6) Install the new filter element by hand until the gasket contacts the filter base.
- (7) Start the engine and check for fuel leaks.
- (8) Stop the engine.
- (9) Close and secure the engine hood.

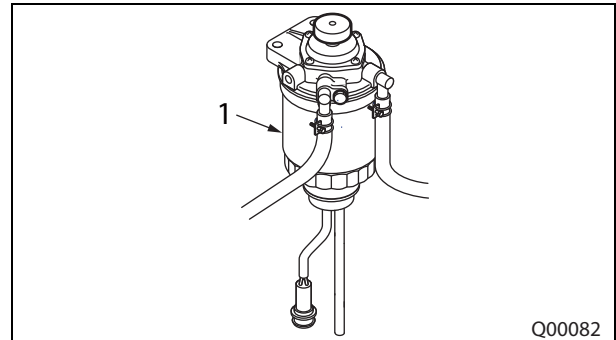

1. Filter element

► Fuel Filter (Gasoline)

Change

- Filter of standard engine should be changed.

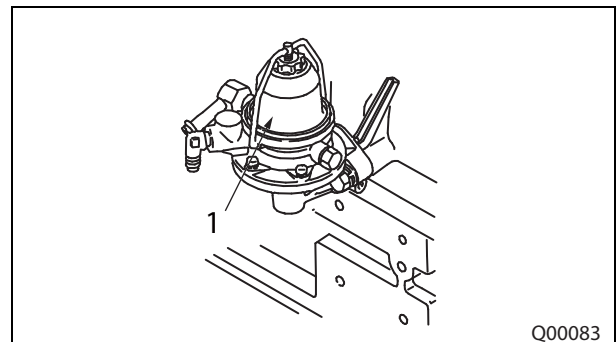

► Antifreeze Solution

The manufacturer recommends that the coolant mix contain 50% commercially available automotive antifreeze, or equivalent, and acceptable water to maintain an adequate water pump cavitation temperature for efficient water pump performance.

Note:

- Do not add pure (100%) antifreeze to the cooling system. Add antifreeze mixed with distilled water using the same freeze protection ratio that is in your cooling system.
- Premix the coolant solution to provide protection to the lowest expected outside (ambient) temperature. Pure undiluted antifreeze will freeze at -23°C (-10°F).
- Use a greater concentration (above 50%) of commercially available automotive antifreeze only as needed for anticipated outside (ambient) temperatures.
- Do not exceed the coolant-to-water mix ratio recommendations provided with the commercially available automotive antifreezes.
- Most commercial antifreezes are formulated for gasoline engine applications and will, therefore, have high silicate content.

Cat Lift Trucks

Operation & Maintenance Manual

GP/GPE15N-35N, DP15ND-35NTS Lift Trucks

99710-36130

◆ Warning Decals, Description

▶ No One under / on Forks

⚠ WARNING

- DO NOT stand or ride on the forks.
- DO NOT stand or ride on a load or pallet on the forks.
- DO NOT stand or walk under the forks.
- DO NOT place any part of your body between the mast and the lift truck chassis.

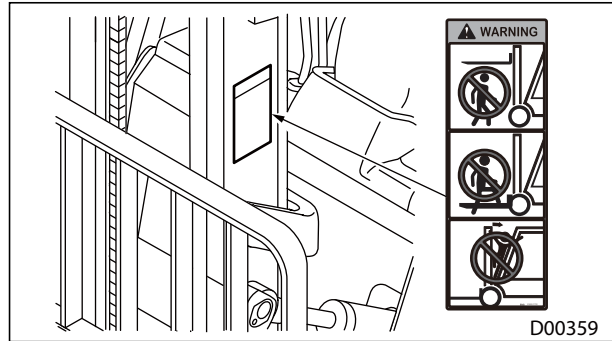

▶ Crush and Pinch Points

⚠ WARNING

Moving Mast-Crush Points.

Keep All Body Parts Clear Of Mast.

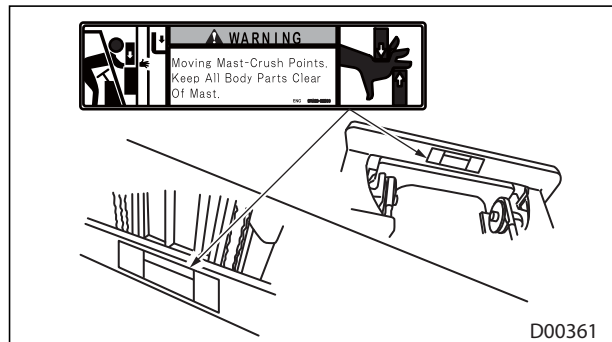

▶ Tipover Warnings

⚠ DANGER

Tipover could occur if truck is improperly operated. Injury or death will result.

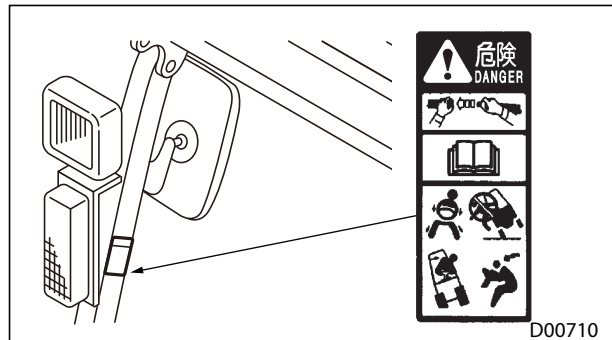

⚠ WARNING

Face the lift truck when getting on and off!

Maintain a three point contact (one foot and two hands) with the foot step, the assist grip, and the seat backrest.

- DO NOT get on or off the moving lift truck.
- DO NOT jump on or off the lift truck.
- DO NOT use the operating control levers or steering wheel as assist grips when entering or leaving the operator compartment.
- DO NOT get on or off the right side of the lift truck.

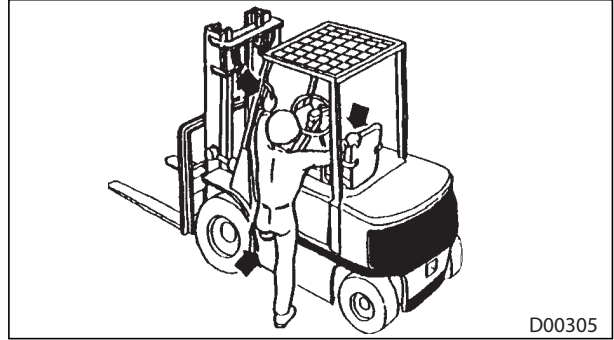

⚠ WARNING

Adjust the operator seat before operating the lift truck!

DO NOT adjust the operator seat while the lift truck is in motion.



⚠ WARNING

Always check overhead clearance!

Serious accidents and damages could be caused by the mast and overhead guard hitting pipes, beams or other overhead obstructions. Watch out for power lines.

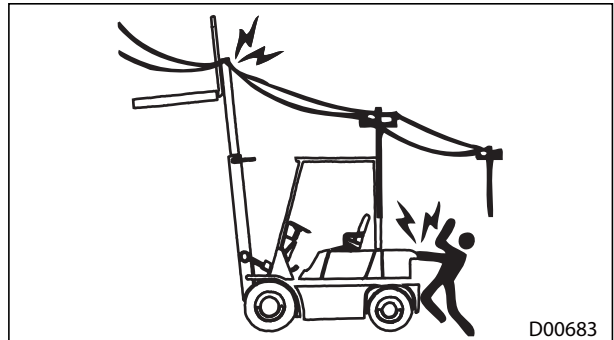

⚠ WARNING

Use lights in dark, dim areas!

Even with lights ON, DO NOT assume people see you and will move out of your way.

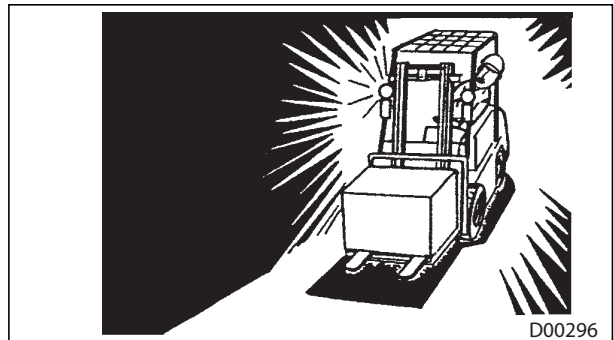

⚠ WARNING

DO NOT use lift truck improperly!

DO NOT use the lift truck for opening or closing railroad car doors, unless the lift truck utilizes an attachment specifically designed for opening and closing railroad car doors.

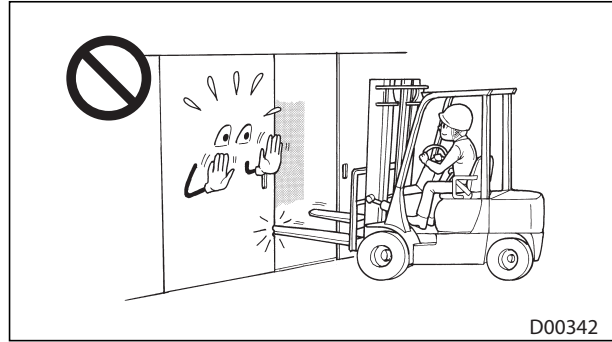

D00342

⚠ CAUTION

Operate the direction lever smoothly!

Avoid sudden changing of traveling direction. This may cause damage to the transmission.

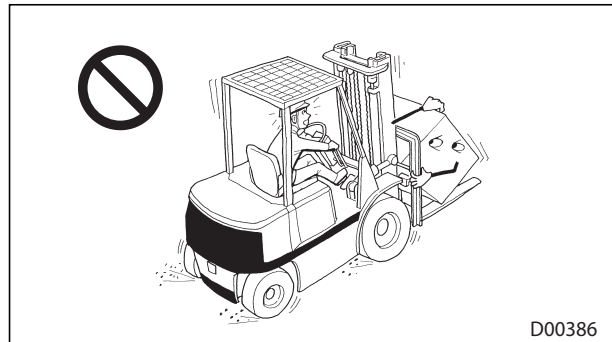

D00386

⚠ WARNING

Always stay within the capacity!

Read the capacity plate to make sure a load is within the capacity of the lift truck before you handle the load.



F00081

⚠ WARNING

Park in authorized areas only!

Park a safe distance from access to fire aisles, stairways and fire equipment. DO NOT park near a flammable material storage area.

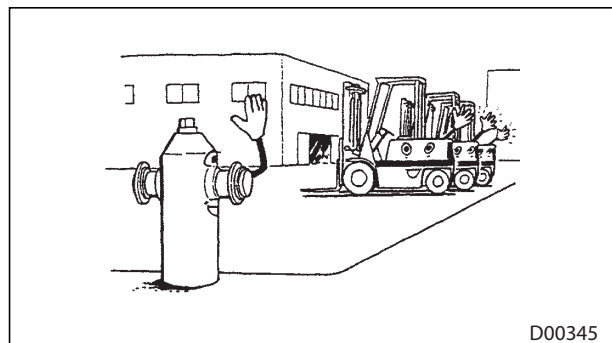

D00345

► Warning and Indicator Icons

When the key switch is turned to the ON position, warning icons and indicator icons will glow. (Except the lamps marked G, D; G for Gasoline and LPG models and D for Diesel models.)

On Diesel models, the warning icon marked * will keep glowing until glow plug heating is completed. If not, LED (Light-Emitting Diode) may have a defect. If LED fails to glow with the key in the ON position, Contact your authorized Cat lift truck dealer.

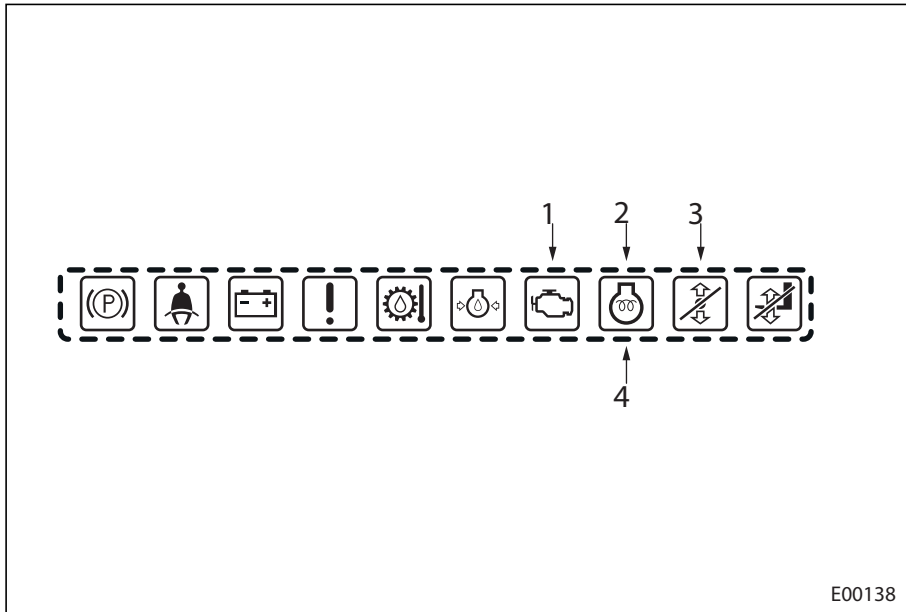

- 1. G
- 2. D
- 3. G, D
- 4. *

E00138

► LCD Screen

The LCD screen consists of main display, fuel gauge, travel direction, symbol mark, time/hour meter and engine coolant temperature gauge. The main display is divided into two parts; right and left.

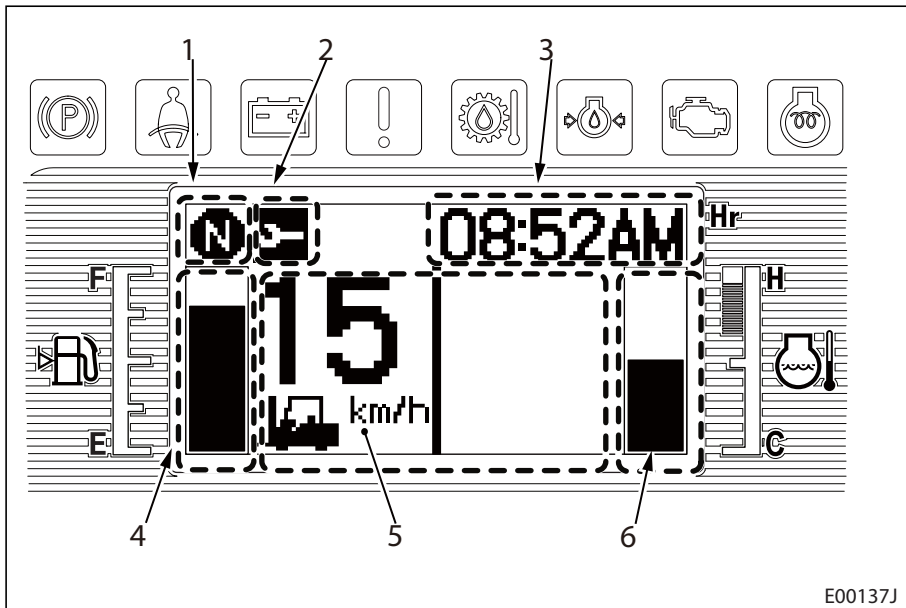

- 1. Travel direction
- 2. Symbol mark (Optional feature)
- 3. Time/hour meter display
- 4. Fuel gauge
- 5. Main display
- 6. Water temperature gauge

E00137J

Over speed warning display

When the pre-set speed limit is exceeded, the speedometer display on the LCD screen will change between black and white alternately. Also the warning buzzer will activate.

- The over speed setting, should be set up by your authorized Cat lift truck dealer.
- Travel speed of lift truck is limited within the range of pre-set speed.

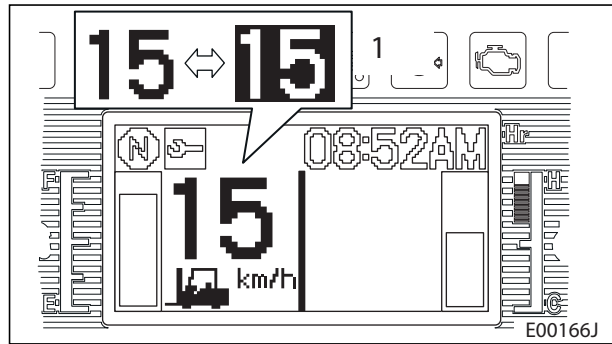

1. Over speed warning display

Load meter display

Load meter display is a function to display load weight.

- The load meter setting, should be set up by your authorized Cat lift truck dealer.

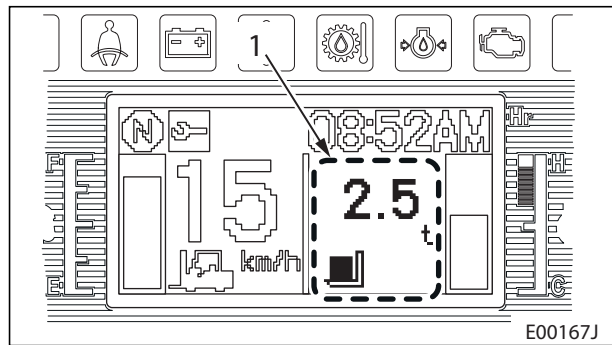

1. Load meter display

Note:

- If equipped with the optional; load weight indicator / display, the weight on the forks will be displayed on the load meter display when the load is lifted. The weight shown can be set to indicate either tons (t) or pounds (lbs). The readout is an estimation of the actual load on the forks.
- The estimation is for reference purposes only and CANNOT be used for legal trade.
- The capacity plate on the lift truck specifies the maximum lifting capacity. Wide loads or extended load centers can change the lift capacity of the lift truck.

Overload warning display

When the pre-set load limit is exceeded, the load meter display on the LCD screen will change between black and white alternately.

Switching the weight unit (t ↔ lb) is available only after the key switch is turned from the OFF position to the ON position.

In order to change the unit, long press the DOWN button (for two seconds). This function is not available when the engine is running.

- The overload warning setting, should be set up by your authorized Cat lift truck dealer.

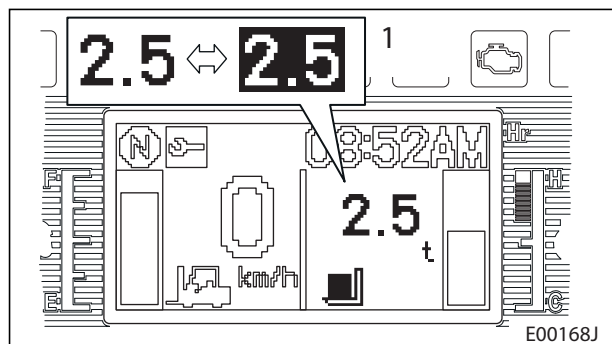

1. Overload warning display

► Forward and Back Adjustment Stopper Knob

⚠ CAUTION

DO NOT insert fingers under this box at the front or rear when adjusting the FC control box forward or backward.

- (1) Loosen the knob to unlock with LEFT HAND.
- (2) In order to adjust the FC control box to an appropriate forward and back position, push forward with RIGHT HAND.
- (3) Tighten the knob to lock with LEFT HAND.
- (4) Make sure that the box is firmly secured.

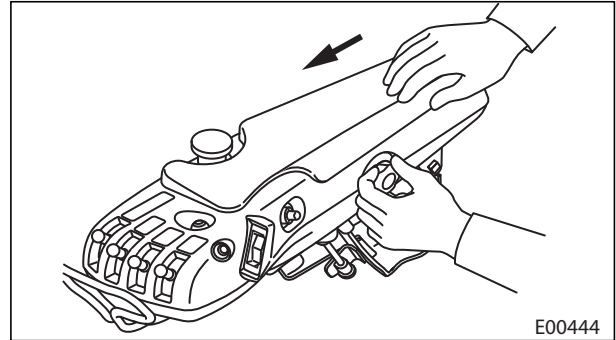

► Up and Down Adjustment Stopper Knob

⚠ CAUTION

DO NOT place fingers around the gas springs or insert fingers into the slot of the adjuster when adjusting the FC control box up or down.

- (1) Loosen the knob to unlock with LEFT HAND.
- (2) In order to adjust the FC control box to an appropriate height, push down with RIGHT HAND. The box is assisted with gas springs.
- (3) Tighten the knob to lock with LEFT HAND.
- (4) Make sure that the box is firmly secured.

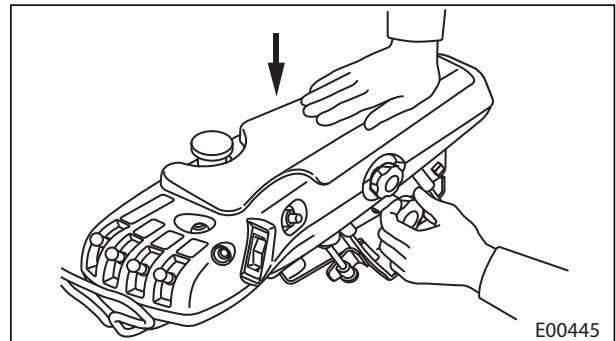

► Direction Switch (Optional)

- Flip the lower switch for forward driving.
- Flip the upper switch for reverse driving.

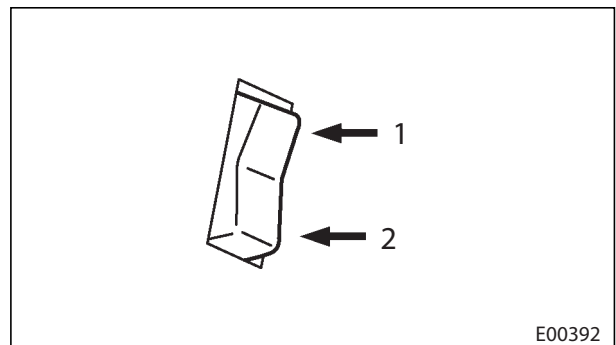

1. Backward

2. Forward

⚠ DANGER

DO NOT jump off your lift truck if it starts to tip over!

- The operator must stay with truck if lateral or longitudinal tipover occurs. The operator should hold on firmly to the steering wheel, brace feet, lean forward and lean away from the point of impact.
- The operator should stay with the truck if it falls off a loading dock or ramp. There are other situations where the environment of the landing area presents a severe hazard. In those incidents, it may be prudent for the operator to leave the truck.



⚠ WARNING

DO handle loads only within the capacity shown on the capacity plate.



⚠ WARNING

DO watch "Tail swing!"

The lift truck may drop off the edge of the dock if you get too close. Always maintain a safe distance from the edge of docks, ramps and platforms.



⚠ WARNING

DO check surface strengths!

Stay away from soft ground to avoid tipover.

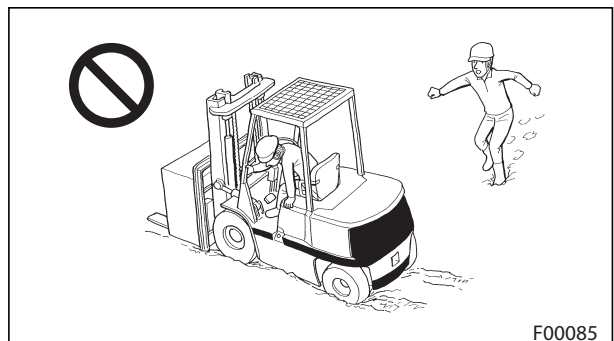

► LPG Model

⚠ WARNING

LP-Gas is flammable and could cause injuries and fires. Inspect LPG fuel lines and fittings for leaks.

⚠ CAUTION

DO NOT leave the key in the ON position when the engine is NOT running. This may cause the battery to run down.

- (1) Open the fuel valve by turning it slowly counterclockwise. Observe the LPG gauge. (If equipped)
- (2) Turn the key switch to the START position. Release the key when the engine starts.
- (3) If the engine does not start, DO NOT press the accelerator pedal. Turn the key switch to the OFF position, then repeat step 2.

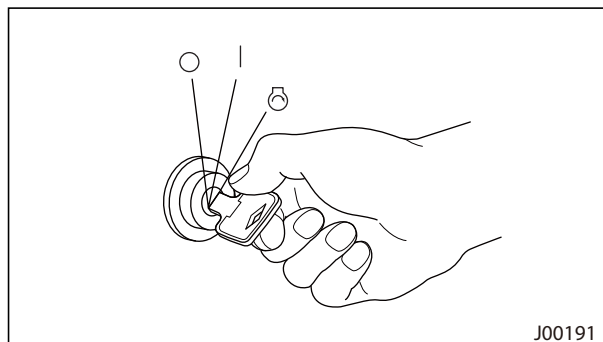

► Diesel Model

⚠ CAUTION

- DO NOT leave the key in the ON position when the engine is NOT running. This may cause the battery to run down.
- DO NOT turn the key switch to the ON position for more than 10 seconds at any one time. This may cause the battery to run down.

- (1) Turn the key switch to the ON position and wait until the glow plug pilot icon goes out.

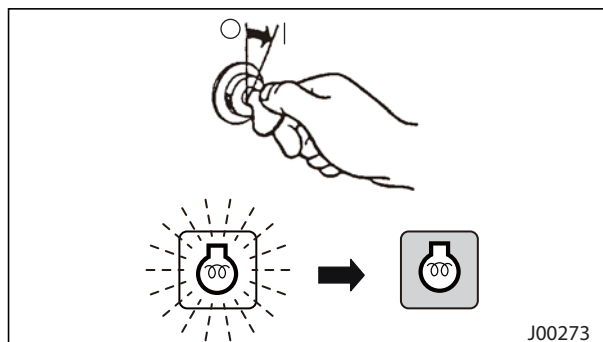

- (2) Press the accelerator pedal fully and hold in this position.

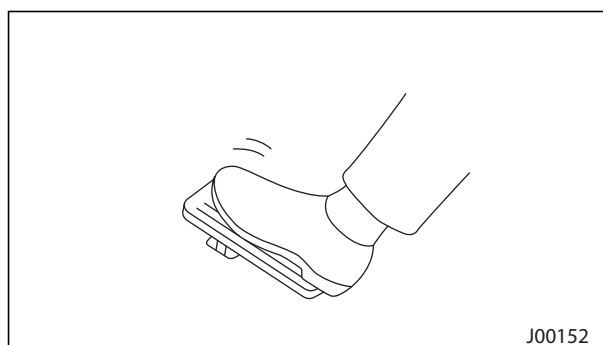

⚠ WARNING

Get off safely

- Get off after the lift truck has come to a complete stop and 5-17 "Parking Lift Truck (After Stopping)" has been followed.
- DO NOT jump off.

⚠ WARNING

Be careful not to drag the forks.

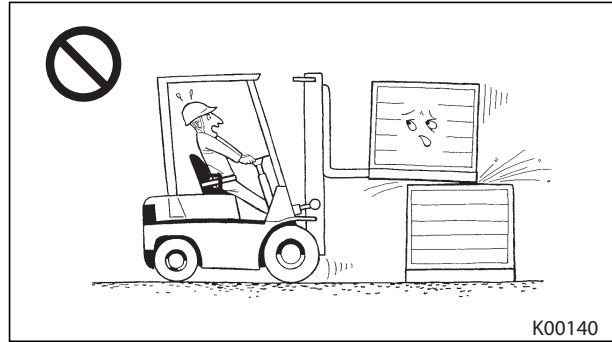

⚠ WARNING

- DO NOT travel with the mast tilted forward or with the load in the elevated position. This will increase the possibility of the lift truck tipping over.
- DO NOT tilt the mast with the load in the elevated position.
- DO NOT leave the lift truck with the load in the elevated position.

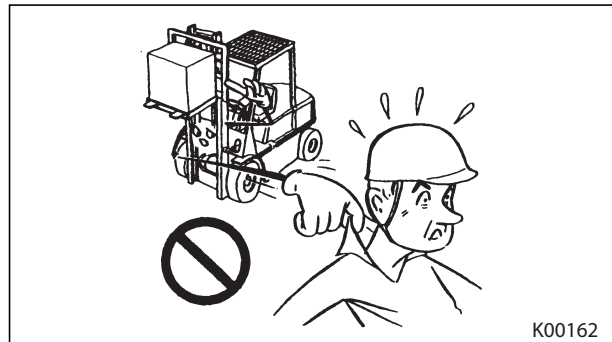

◆ Working on Grades

▶ Normal Travel Position

- Keep the forks or the load at a safe travel height, which is 15 to 20 cm (6 to 8 in.) from the ground.
- Tilt the mast back more than 6° when the lift truck is empty. Tilt the mast fully backward when the lift truck is loaded.

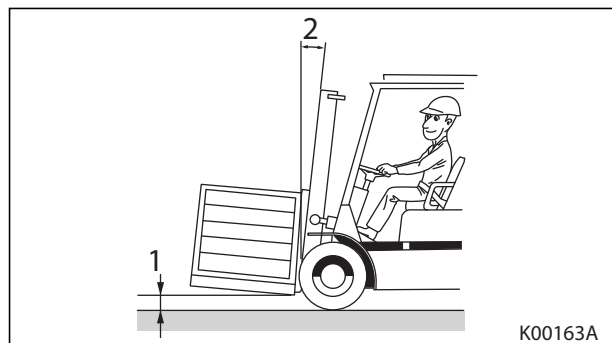

1. 15 to 20 cm (6 to 8 in.) 2. 6° Tilt back

▶ Traveling on a Grade

⚠ WARNING

- DO NOT continuously use the brake pedal alone. This could result in brake failure and an accident.
- DO NOT use the inching pedal when traveling down a grade. This prevents the engine from acting as a brake.
- DO NOT place the direction lever in the NEUTRAL position when traveling down a grade.

TROUBLESHOOTING

► To Add Air to Tires

⚠ WARNING

- The lift truck uses high pressure tires. DO NOT overinflate the tire.
- When adding air, check the rim for damage that could permit air to leak from the tire.
- The use of an inflation cage, or some other safety device, helps reduce the risk of serious injury.
- When adding air to the tire, or when checking tire pressure, BE SURE to keep your body away from the side.



⚠ WARNING

- When adding air to the tire using an air compressor, make sure the compressor valve is correctly set. Failure to follow this precaution could damage the tire.
- Always maintain correct tire pressure.



► Dual Tire (Optional)

Steps other than the followings are the same as those for single-wheel lift trucks.

- (1) Remove extension valve.
- (2) Unscrew outer wheel nuts and remove the outer wheel.
- (3) Unscrew inner wheel nuts and remove the inner wheel.
- (4) Install the inner wheel and, after lowering the lift truck, tighten inner wheel nuts to the specified torque.
- (5) Raise the lift truck again, install the outer wheel. After lowering the lift truck, tighten outer wheel nuts.

Note: Check inner wheel nuts for tightness even when replacing the outer wheel.

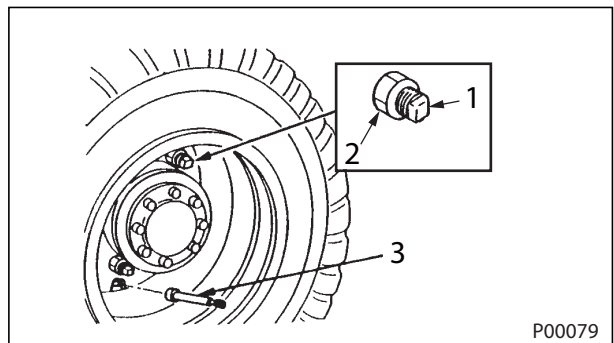

1. Inner wheel nut
2. Outer wheel nut

3. Extension valve

◆ Inspection Precautions

⚠ WARNING

If the lift truck requires any repair, attach a "DO NOT OPERATE" or similar warning tag to the steering wheel or other controls, remove the key from the key switch, and contact your authorized Cat lift truck dealer.

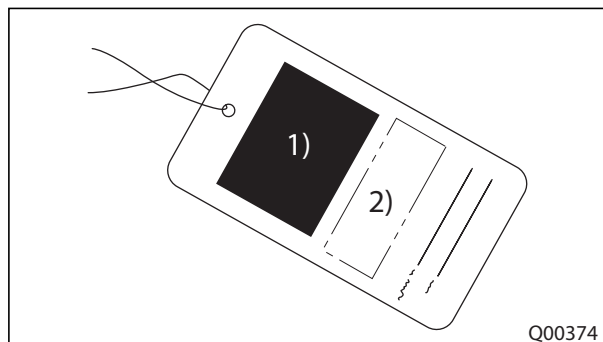

1) DANGER

2) DO NOT OPERATE

⚠ WARNING

If it is necessary to make an inspection while the engine is running, ALWAYS USE TWO WORKERS---one, the operator, at the controls and the other checking within visual contact of the operator.

⚠ CAUTION

A daily (Pre-Start) inspection is the key to safety. At the beginning of each shift, check your lift truck to make sure it is in a safe operating condition. Always inspect your lift truck under the following conditions.

- Lift truck on level ground
- Mast in vertical position
- Fork tips on ground
- Engine stopped
- Control levers in neutral.
- Wheels blocked.

⚠ CAUTION

- Avoid mixing lubricants. In some cases, different brands of lubricants are not compatible with each other and deteriorate when mixes. It is best to stick with the same brand at successive service intervals.
- Before refilling, clean filler holes. After filling, clean up spills.

⚠ CAUTION

Contact your authorized Cat lift truck dealer for the proper disposal of wastes accumulated after replacement of tires, batteries, oils and fluids.

- (1) Carefully inspect the forks for cracks. Special attention should be given to the heel section A, all weld areas and mounting brackets B.

Note: Do not use cracked forks. "Wet Test" magnetic particle inspection is generally recommended due to its sensitivity and the ease of interpreting the results. Portable equipment is usually recommended so it can be easily moved to the lift truck. Contact your authorized Cat lift truck dealer for further information.

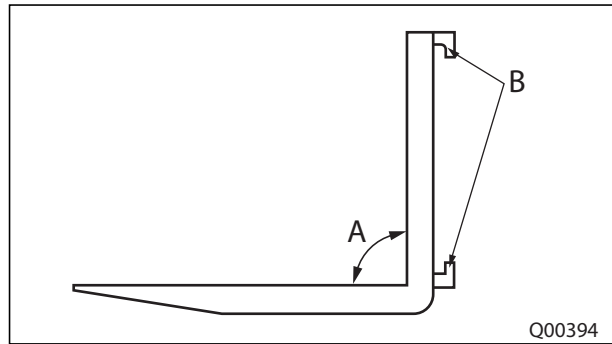

- (2) Check the difference in height of one fork tip to the other when mounted on the lift bracket. Also check each fork for its deviation by setting a straight fork length pole against the fork to measure a difference in height between the fork tip and pole.

Note: A difference in fork tip height could result in uneven support of the load and cause problems when entering loads. The maximum allowable difference in fork tip elevation C is 5 mm (0.2 in.) for pallet forks. Replace one or both forks when the difference in fork tip height exceeds the maximum allowable difference.

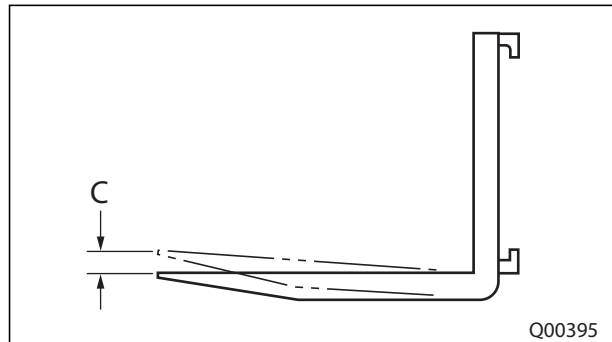

- (3) Check the fork blade D.

Note: Do not use the forks if the thickness is reduced to less than the tolerant thickness. Fork blade length may also be reduced by wear, especially on tapered forks and platens. Do not use the forks when the blade length is no longer adequate for the intended loads.

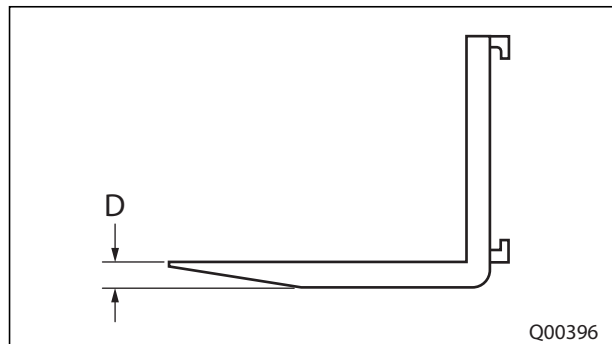

Tolerant Thickness	Standard	Limit
1 to 2 ton compact models	35 mm (1.4 in.)	32 mm (1.3 in.)
2 to 2.5 ton models	40 mm (1.6 in.)	36 mm (1.4 in.)
3 to 3.5 ton models	45 mm (1.7 in.)	40 mm (1.6 in.)

► Load Backrest Extension

Is the load backrest extension free of distortion, cracks and other defects? Shake the load backrest extension to check for excessive rattle.

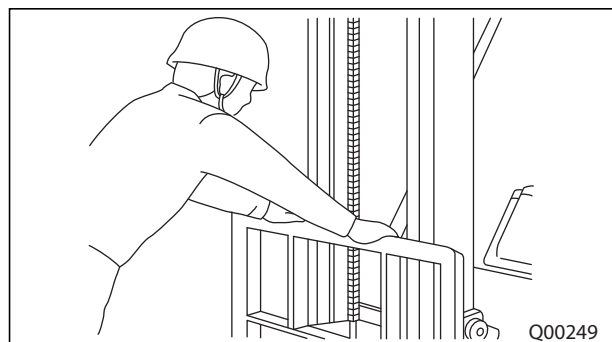

MAINTENANCE

► Inching Pedal (Powershift Model)

- Is the free play correct?
- Does the inching pedal return to the full, upward position?

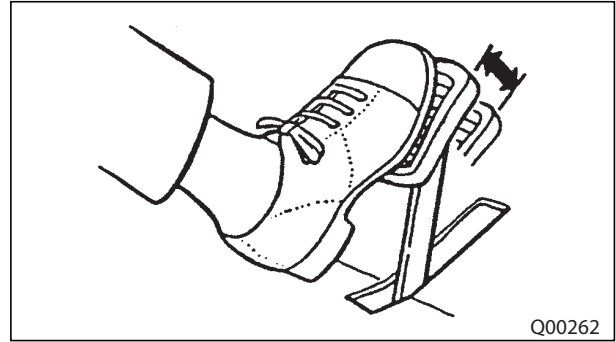

Q00262

Correct free play

Models	Value
1 to 3.5 ton	2.5 to 7.5 mm (0.1 to 0.3 in.)

► Clutch Pedal (Manual Model)

Check the play of clutch pedal.

Play	
1 to 3.5 ton	0.6 mm (0.02 in.)

► Accelerator Pedal

- Can you press the accelerator pedal smoothly without any sign of rubbing?
- Does the accelerator pedal return to the full, upward position?

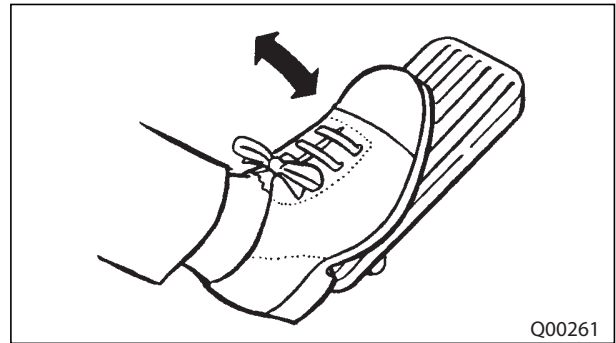

Q00261

⚠ WARNING

- DO NOT wash the air cleaner element.
- DO NOT use damaged air cleaner element.
- DO NOT operate the lift truck without the air cleaner element installed. If not followed, dust, water droplets or foreign objects will get in the engine, which may result in engine damage.

Note: Park the lift truck on level ground with the forks lowered until the fork tips touch the ground, parking brake applied, direction lever in the NEUTRAL position, engine stopped and the wheels blocked.

- (1) Raise the engine hood.
- (2) Unclamp the dust cup (at 3 places) and take out the element.
- (3) Clean the inside of the air cleaner housing.
- (4) Direct air inside the element along the pleats, and lightly tap it.
- (5) Insert a light inside a clean element and check.
- (6) Replace the element if tears or rips are found.
- (7) Install the air cleaner element.
- (8) Close the engine hood.

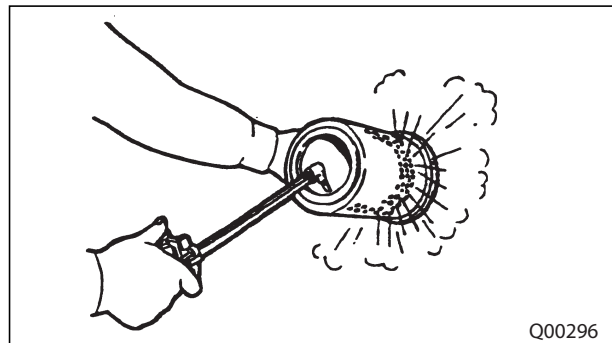
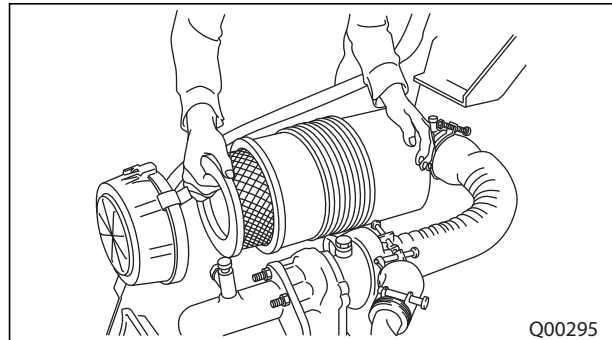

Note:

- Double-cyclone cleaner element (optional) requires cleaning of its outer element only.
- DO NOT service the air cleaner with the engine running.
- DO NOT clean the elements by pounding them against another object.
- Always inspect the element before and after cleaning.
- After the fifth cleaning, you must replace the air cleaner element even if it is within the scheduled maintenance period.
- Clean and replace more frequently in corrosive or abrasive environments.

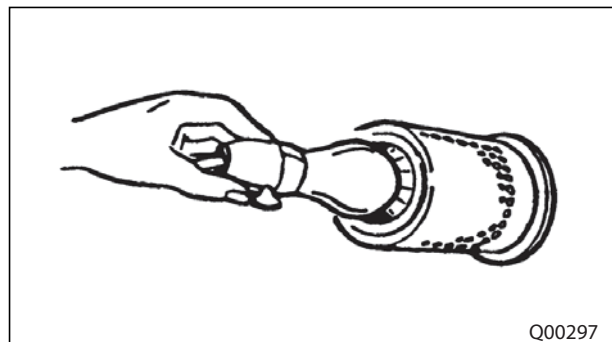

MAINTENANCE

- (2) Turn the radiator filler cap slowly to relieve the pressure, then remove the cap.

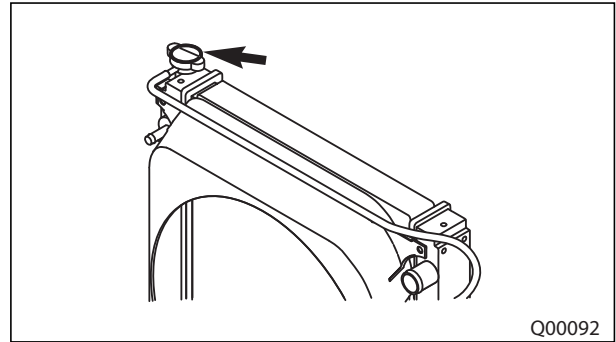

- (3) Open radiator drain valve. Allow the coolant to drain.
- (4) Drain the reserve tank.
- (5) Close the radiator drain valve.
- (6) Fill the cooling system with 1 kg sodium bisulfate per 40 liters of water. Most commercial cooling system cleaners can be used.
- (7) Start and run the engine for 30 minutes.
- (8) Stop the engine and drain the cleaning solution.
- (9) Flush the system with clean water until the draining water is clear.
- (10) Close the drain valve. Fill the system with neutralizing solution, 250 g sodium carbonate per 40 liters of water.
- (11) Start and run the engine for 10 minutes.
- (12) Stop the engine and drain the neutralizing solution.
- (13) Flush the system with clean water until draining water is clear.
- (14) Close the drain valve.

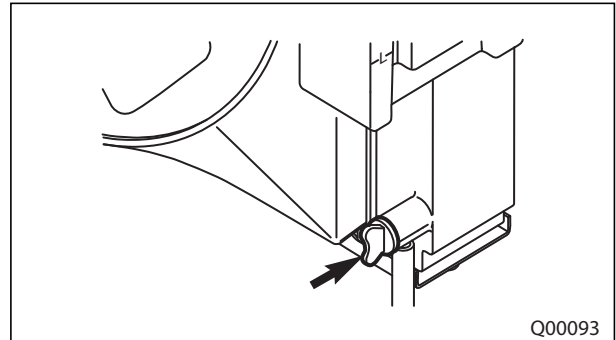

- (15) Mix a coolant solution of distilled water and antifreeze.
- (16) Fill the cooling system. See 12-11 "Refill Capacities". To avoid air locks, add the coolant slowly.

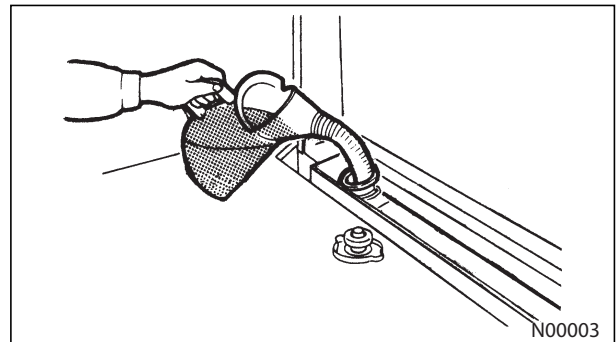

- (17) Start and run the engine until the coolant level is stabilized.
- (18) Stop the engine.
- (19) Add coolant, if necessary, to maintain the level to below the bottom of the filler hole.
- (20) Put the radiator filler cap back on.

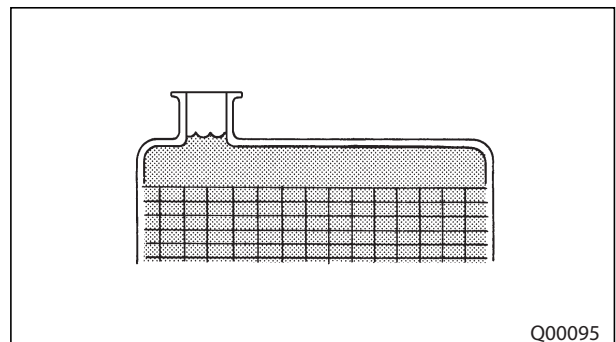

SERVICE DATA

◆ Refill Capacities

Item		Truck model						
		GP15N	DP15ND DP15NT DP15NDS DP15NTS DP15N	GPE15N	GP15ZN	GP20CN	GPE20CN	DP20CND DP20CNT DP20CND DP20CNTS DP20CN
Refill Capacities liter (U.S. gal.)	Fuel Tank	53 (14)						
	Engine Cooling System -- 0.65 liter (1.4 pt) reserve tank included	7.4 (2.0)	6.8 (1.8)	7.4 (2.0)	6.8 (1.8)			
	Engine Lubrication System	Crankcase	3.5 (0.9)	7.5 (2.0)	3.5 (0.9)			7.5 (2.0)
		Oil Filter	0.3 (0.1)	1.0 (0.3)	0.3 (0.1)			1.0 (0.3)
		Total	3.8 (1.0)	8.5 (2.2)	3.8 (1.0)			8.5 (2.2)
	Transmission	Manual model	4.0 (1.1)					
		Powershift	8.0 (2.1)					
	Transfer and Differential	5.5 (1.5)						
	Hydraulic Tank N level	28 (7.4)						
Brake Fluid Reserve Tank, cc	135 (35.7)							
Battery Electrolyte Specific Gravity, corrected to 20°C (68°F)		1.26 to 1.28						

Note: The service data are subject to change without notice.

3.14	Horn	3-24
3.15	Rear Combination Light	3-24
3.16	Rear Combination Harness	3-25
3.17	Front Combination Light	3-26
3.18	Front Combination Harness	3-27
3.19	Stop Light Switch	3-27
3.20	Backup Light Switch (Manual T/M Truck)	3-28
3.21	Neutral Switch	3-28
3.22	Thermoswitch (Engine Coolant Temperature)	3-29
3.23	Thermoswitch (T/C Oil)	3-30
3.24	List of Lights	3-31
4.	Battery and Maintenance	3-32
4.1	State of Charge in Specific Gravity and Adjustment	3-32
4.2	Relationship Between Electrolyte Specific Gravity and State of Charge	3-32
4.3	Precautions for Battery Charging	3-33
5.	Meter Panel	3-34
5.1	Meter Panel Layout	3-34
5.2	Basic Display	3-35
5.3	Basic Operation	3-39
5.4	When A Warning Occurs	3-45
5.5	Diagnostic Code	3-47
5.6	Warning Lights	3-48
5.7	Optional Functions	3-49
5.8	Hour Meter	3-56
5.9	Troubleshooting	3-58
6.	Wire Color	3-59
6.1	List of Wire Color Codes	3-59
7.	Troubleshooting	3-60
7.1	Engine Startup Problem	3-60
7.2	Gauge-related Problem	3-60
7.3	Lightning-related Problem	3-61
7.4	Warning System Problem	3-62
7.5	Battery-related problem	3-63
8.	Electrical Wiring Diagram	3-64

Chapter 4 CONTROLLER

1.	Outline	4-1
2.	Main Functions of Controllers	4-2
2.1	Meter panel	4-3
2.2	VCM -1M (Vehicle Control Module)	4-3
2.3	ECM (Gasoline Engine Control Module)	4-3
2.4	GSE Connector	4-4
3.	Service Tool	4-5
3.1	Service Tool Menus	4-5
3.2	Toolbox	4-7
4.	Mast Interlock System	4-20
4.1	Mast Interlock Function	4-20

2.18	Mast Rollers and Strips, Removal and Installation Without Removing Mast from Truck	14-50
2.19	Inspection and Adjustment	14-51
2.20	Inspecting Forks (All Mast Models)	14-51
2.21	Chain Tension, Inspection and Adjustment (All Mast Models)	14-53
2.22	Measuring Chain Elongation (All Mast Models)	14-54
2.23	Adjusting Clearance Between Lift Bracket Roller and Inner Mast (All Mast Models)	14-55
2.24	Adjusting Mast Roller Clearance (All Mast Models)	14-56
2.25	Inspecting and Adjusting Mast Strip Clearance (All Mast Models)	14-58
2.26	Adjusting Mast Tilt Angle (All Mast Models)	14-59
2.27	Inspecting and Adjusting Right and Left Lift Cylinder Stroke (All Mast Models)	14-59
2.28	Troubleshooting	14-60
2.29	Service Data	14-61
3.	Triplex Mast	14-64
3.1	Mast System	14-64
3.2	Structure and Functions (5M15D to 5M35D)	14-65
3.3	Mast and Lift Bracket Assembly, Removal Sequence	14-67
3.4	Suggestions for Removing Mast and Lift Bracket Assembly	14-67
3.5	Suggestions for Installing of Mast and Lift Bracket Assembly	14-69
3.6	Mast and Lift Bracket, Disassembly Sequence (All Mast Models)	14-70
3.7	Preparation for Disassembly of Mast and Lift Bracket	14-70
3.8	Suggestions for Disassembly of Mast and Lift Bracket	14-71
3.9	Mast and Lift Bracket, Inspection (All Mast Models)	14-72
3.10	Lift Bracket Roller, Assembly Sequence (All Mast Models)	14-73
3.11	Lift Bracket Clearance Adjustment (All Mast Models)	14-74
3.12	Installing Mast Rollers (All Mast Models)	14-76
3.13	Installing Mast Strips (All Mast Models)	14-77
3.14	Installing Second Lift Cylinder	14-78
3.15	Installing First Lift Cylinder	14-79
3.16	Connecting Chains	14-80
3.17	Installing Hydraulic Lines	14-81
3.18	Mast Rollers and Strips, Removal and Installation Without Removing Mast from Truck	14-83
3.19	Inspection and Adjustment	14-84
3.20	Inspecting Forks (All Mast Models)	14-84
3.21	Chain Tension, Inspection and Adjustment (All Mast Models)	14-86
3.22	Measuring Chain Elongation (All Mast Models)	14-87
3.23	Adjusting Clearance Between Lift Bracket Roller and Inner Mast (All Mast Models)	14-88
3.24	Adjusting Mast Roller Clearance (All Mast Models)	14-89
3.25	Inspecting and Adjusting Mast Strip Clearance (All Mast Models)	14-91
3.26	Adjusting Mast Tilt Angle (All Mast Models)	14-92
3.27	Inspecting and Adjusting Right and Left Lift Cylinder Stroke (All Mast Models)	14-92
3.28	Troubleshooting	14-93
3.29	Service Data	14-94

4. Fan Belt, Installing

For installation, follow the removal sequence in reverse.

4.1 Suggestions for Installation

- (1) Before installing the belt, turn the fan to check for smooth rotation. Replace the bearing if it generates abnormal noises.
- (2) Make sure that tension pulley moves when pushing the belt by hand.
- (3) Tighten lock bolt and locknut firmly.

5. Cooling System, Inspecting and Adjusting

5.1 Fan Belt Inspection

- (1) Check the belt for contamination by oil, grease, or dust. Replace the belt as required. When there is slight contamination, clean the belt with a rag or paper towel. Do not wash with gasoline, oil, or any other solvent.
- (2) During engine overhaul or belt tension adjustment, carefully check condition of belt. If it has any damage, replace belt with new one.

5.2 Fan Belt Tension Adjustment

⚠ WARNING

Always turn the engine OFF when adjusting fan belt tension.

Adjust the belt deflection to the specified range below, while applying force of 98 N (10.0 kgf) [22.03 lbf] perpendicularly to the belt midway between fan pulley and tension pulley.

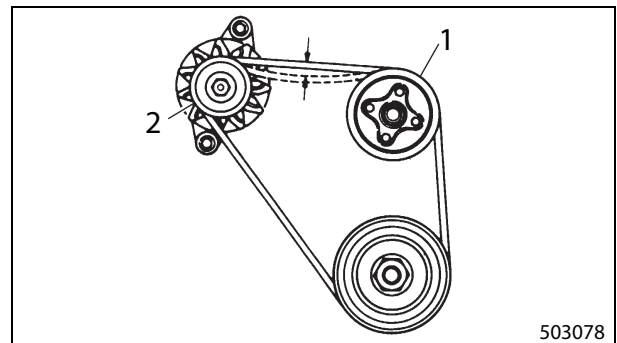

1. Fan pulley

2. Tension pulley

Item	Standard	
	Gasoline models	Diesel models
Deflection	11 to 13 mm (0.43 to 0.51 in.)	10 to 12 mm (0.39 to 0.47 in.)

3.4 Key Switch (Anti-Restart Switch)

Key switch

The diesel model is equipped with a distributor type injection pump. The key switch is equipped with a fuel cut mechanism to stop the engine automatically.

The gasoline-engine truck is also equipped with an fuel cut engine automatic stop mechanism.

Anti-restart key switch

This key switch has an anti-restarting function.

The key switch will not turn from the ON to the START position while the engine is running to prevent engine trouble or starter breakage due to improper operation when starting the engine.

The gasoline and diesel models use the same key switch. On the diesel model, the switch wire is connected so that the engine is preheated with the key switch in ON position.

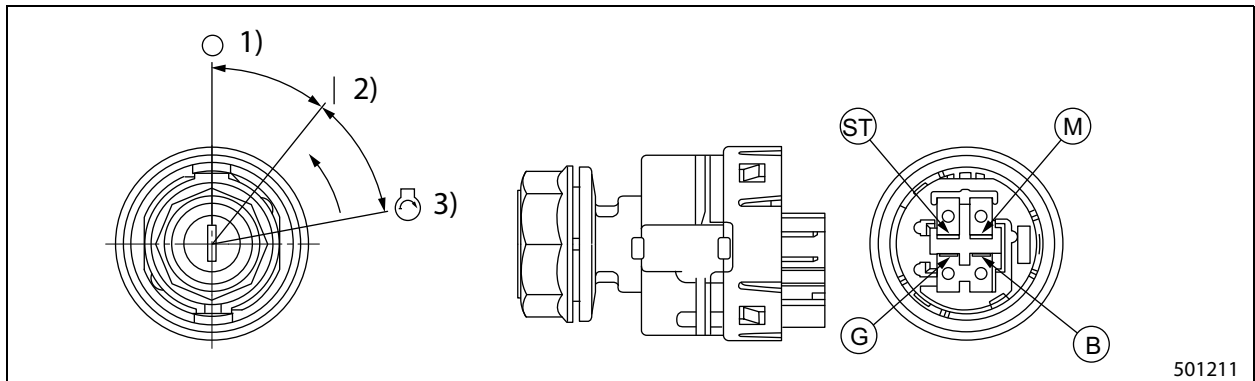

1) OFF

2) ON

3) START

Connecting diagram (for gasoline model 12V)

Terminal	G	B	M	ST	Key insert/removal
OFF	○ -----	----- ○			Yes
ON (during operation)	○ -----	----- ○ -----	----- ○		No
START (when starting engine)	○ -----	----- ○ -----	----- ○ -----	----- ○	No

Note: Dashed line between terminals of G and B shows external coupled circuit.

3.16 Rear Combination Harness

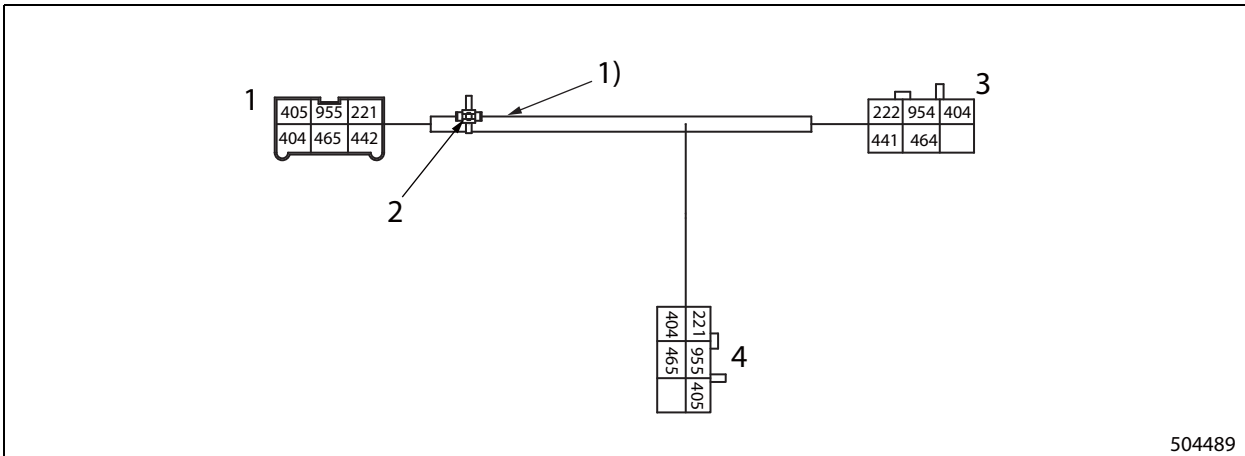

- 1. Harness
- 2. Clip
- 3. Rear combination light (R.H.)
- 4. Rear combination light (L.H.)
- 1) Protect with corrugated tube

Note: Use AVS, CAVS or AVSS as the power source.

Circuit	Wire diameter	Wire color code	Destination
955	0.85	B	Rear combination light LH (GND) to harness
954	0.85	B	Rear combination light RH (GND) to 955
465	0.5	L/R	Rear combination light LH (backup light) to harness
464	0.5	L/R	Rear combination light RH (backup light) to 465
442	0.5	Y/L	Rear combination light LH (stop light) to harness
441	0.5	Y/L	Rear combination light RH (stop light) to 442
405	0.5	G/R	Rear combination light LH (turn signal light) to harness
404	0.5	G/B	Rear combination light RH (turn signal light) to harness
221	0.85	R/B	Rear combination light LH (tail light) to harness
222	0.5	R/B	Rear combination light RH (tail light) to 221

Engine coolant temperature - the number of dots on screen

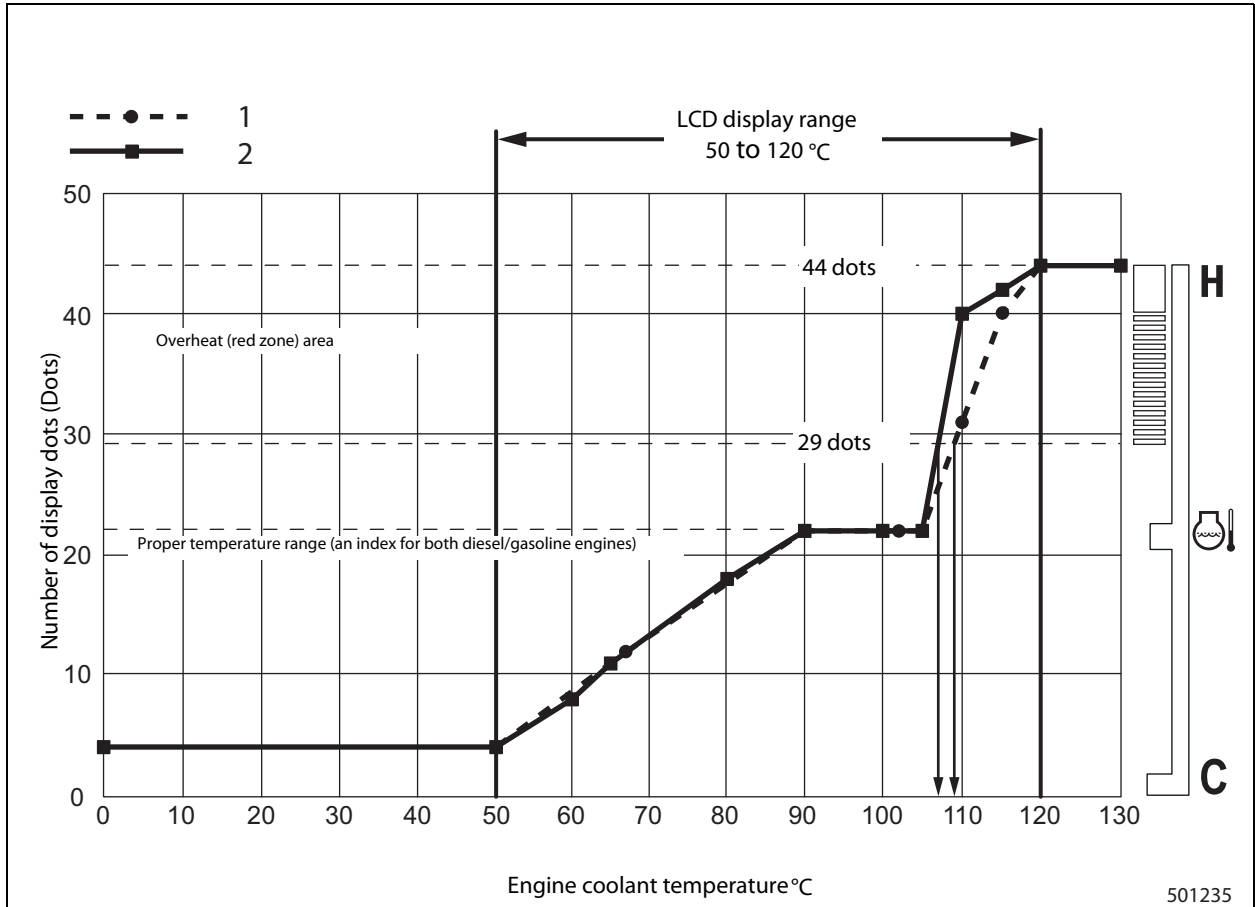

1. Diesel engine models
2. Gasoline engine models

Note: Red zone is 29 dots or more.
 Diesel models: about 109 °C (228 °F) or higher
 Gasoline models: about 107 °C (225 °F) or higher

Travel direction display

The truck traveling direction is displayed. If the direction lever is not in the N (NEUTRAL) position when starting the engine, the symbol "N" blinks and the engine will not start. If an operator leaves the seat while the engine is running and the direction lever is not in the N (NEUTRAL) position, the symbol "N" blinks and the transmission is electrically shifted to the NEUTRAL.

Note:

- Travel direction display is switched by the signal from the direction lever.
- Manual T/M truck shows N (NEUTRAL) only, and does not show forward and reverse.
 Also, blinking N (Driving interlock indication) is not shown.

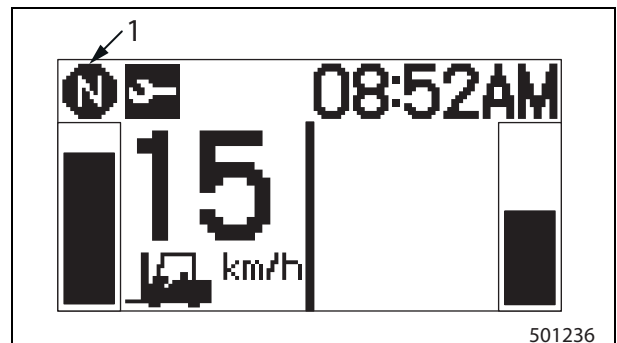

1. Truck direction indicator

Overspeed warning display (Dealer option)

When the pre-set speed limit is exceeded, the image of the speedometer display alternately changes between black characters on a white background to white characters on a black background, and the warning buzzer activates at the same time. For setting up the overspeed warning display, use the service tool. (For details, see the service tool manual.)

Note:

- ONLY a service engineer should perform the overspeed warning display setting.
- When the overspeed limit function is used, set the travel speed value within the speed limit.
- Over speed warning display can not be used for lift trucks used on public roads. Note that the buzzer setting only is available.

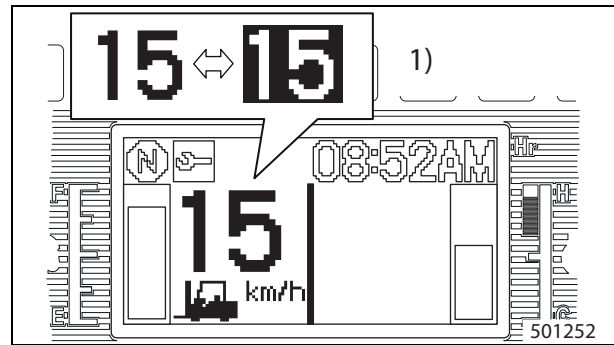

1) The travel speed display changes between black on white and white on black.

Load meter display (Manufacturer's option)

The function of load meter display is to detect and display the weight of load that is being carried. For setting up the load meter display, use the service tool. (For details, see the service tool manual.)

Note: ONLY a service engineer should perform the load meter display setting.

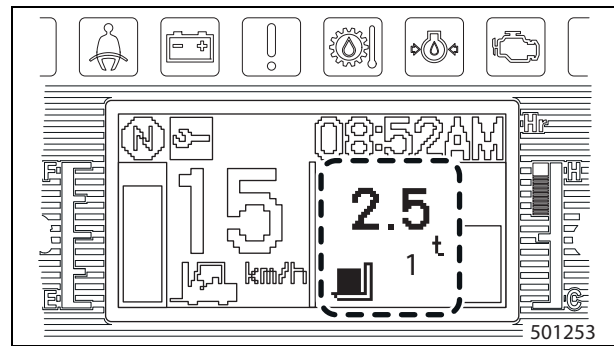

1) Load meter display

Overload warning display (Manufacturer's option)

When the pre-set load weight is exceeded, the image of the load display alternately changes between black characters on a white background to white characters on a black background, and the warning buzzer is activated. For setting up the overload warning display, use the service tool. (For details, see the service tool manual.)

Note:

- ONLY a service engineer should perform the overload warning display setting.
- To use the overload warning display function, the setup of the load meter display function is required.

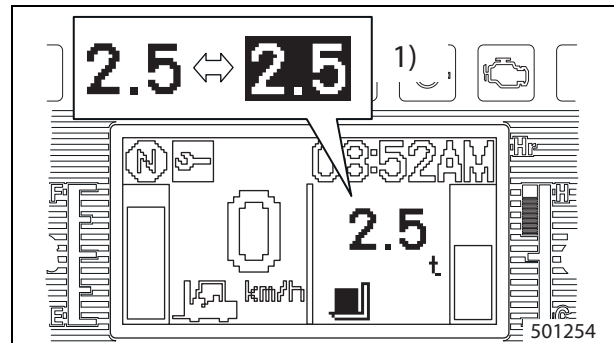

1) The load weight display changes between black on white and white on black.

8. Electrical Wiring Diagram

3. Service Tool

3.1 Service Tool Menus

Select functions from the main menu window.

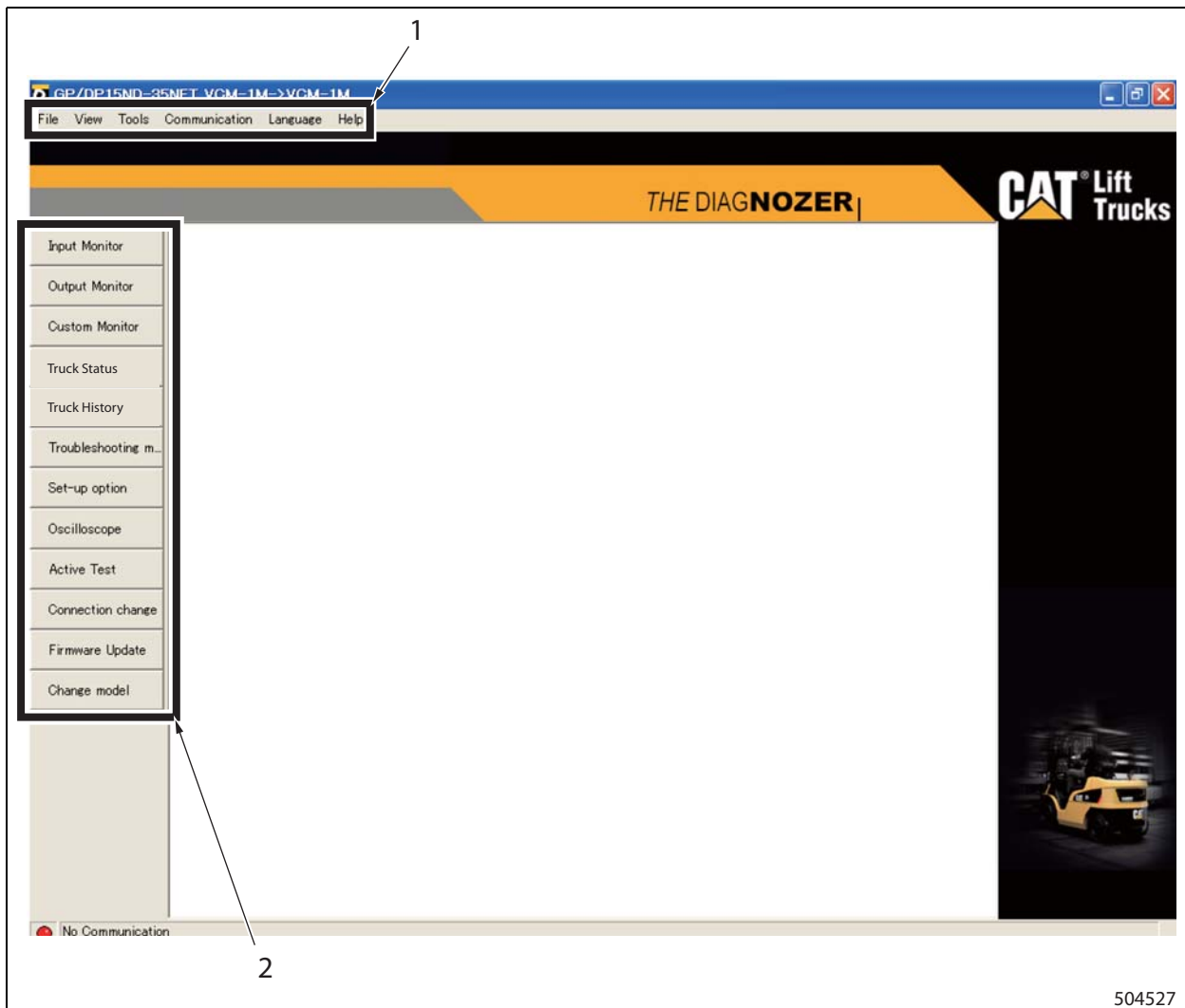

1. Menu items

2. Toolbox

File menu

- Print: allows you to print the screen being displayed.
- Exit: allows you to terminate the application.

Monitor menu

- Input Monitor: allows you to monitor input values.
- Output Monitor: allows you to monitor output values.
- Custom Monitor: allows you to monitor customized input/output values.
- Truck Status: allows you to monitor the current diagnostic status.
- Truck History: allows you to view the past warnings.

Connection change

Click the connection change button from the menu or toolbox to display the connection/target change dialog box. The connection/target change dialog box allows you to change the connecting controller and target controller. To change the connection, select the controller being connected to the cable from the selection box on the right. To change the target, select an appropriate controller from the selection box of target on the right. After the selection of the connection and target, click the OK button. Then the change of connection and target controllers will be executed. Click the Cancel button if you wish it unchanged.

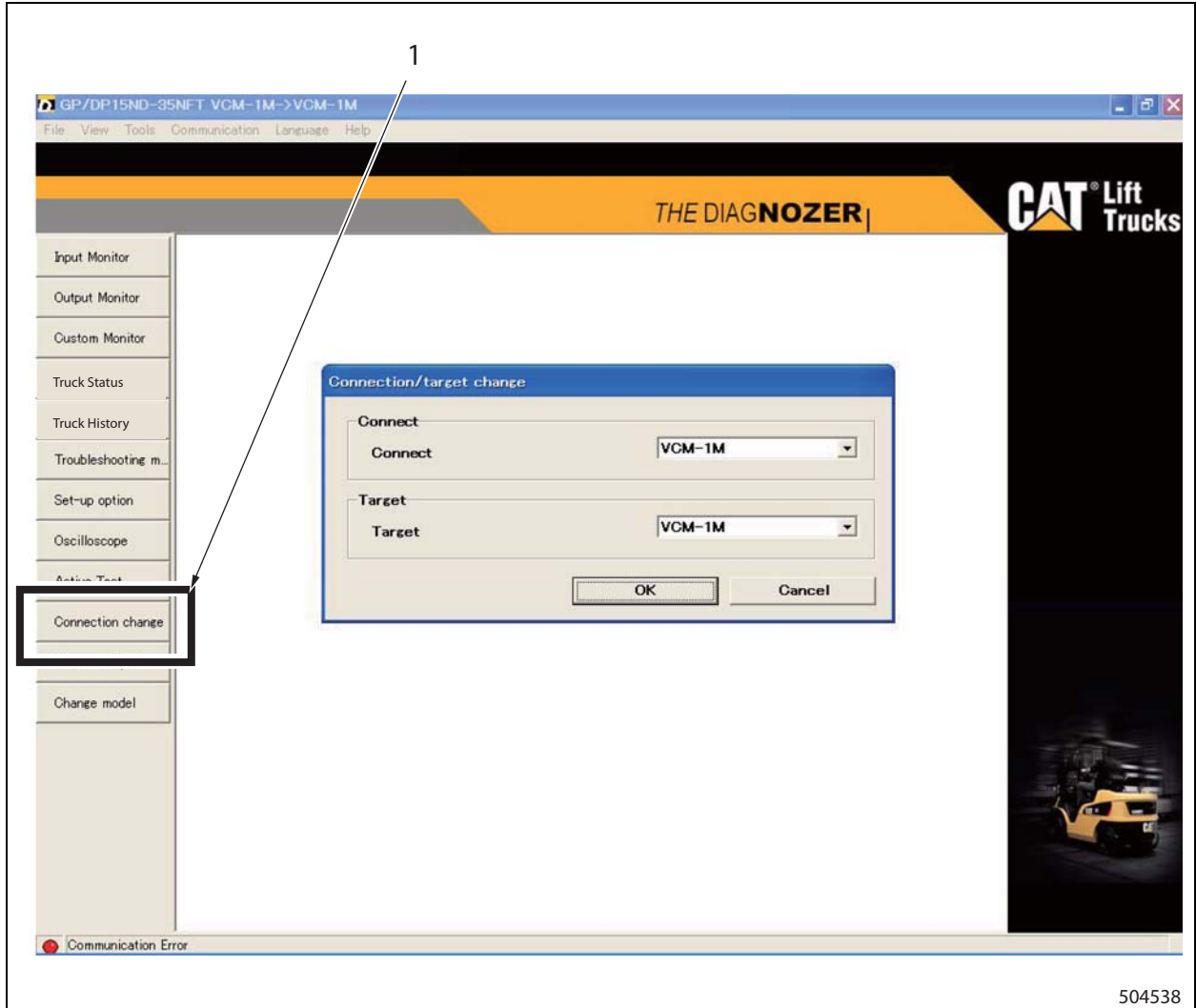

1. Connection change button

5.3 Active Test Inspection Procedure

⚠ CAUTION

The active test inspection causes the front wheels to rotate at a creep speed. Before conducting the active test inspection, be sure to block or raise the front wheels to prevent the truck from moving.

- (1) Connect the service tool and turn the key switch to the ON position.
(DO NOT start the engine.)
- (2) Display the active test screen by pressing the active test button in the service tool screen.

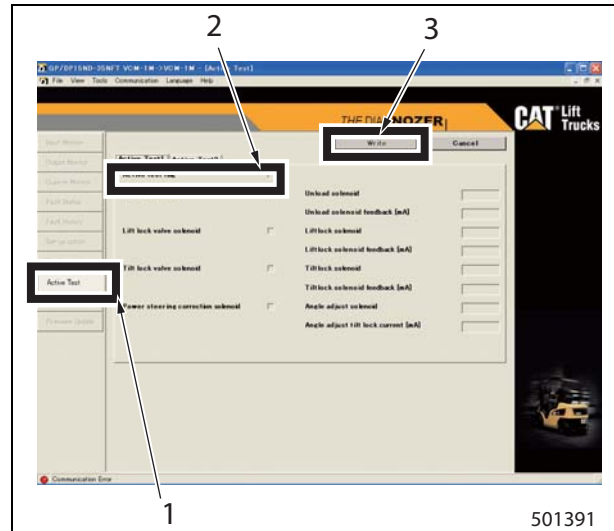

1. Active test
2. Active test flag
3. Write button

- (3) Insert a check mark in the box of the active test flag, and press the write button. When the write confirmation dialogue box is displayed, press the YES button.

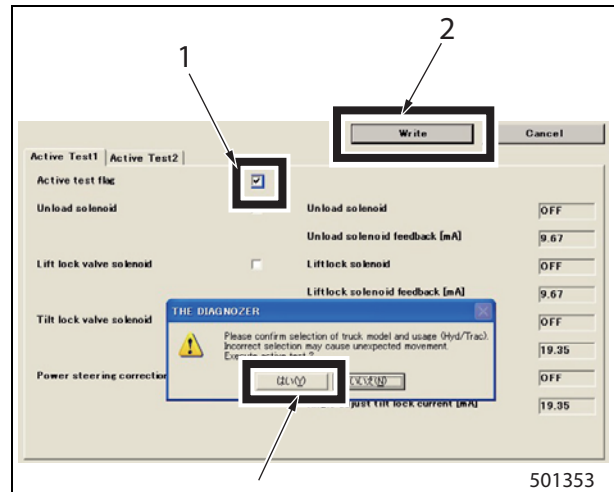

1. Check mark
2. Write button

- (4) When the write completed dialogue box is displayed, press the OK button.

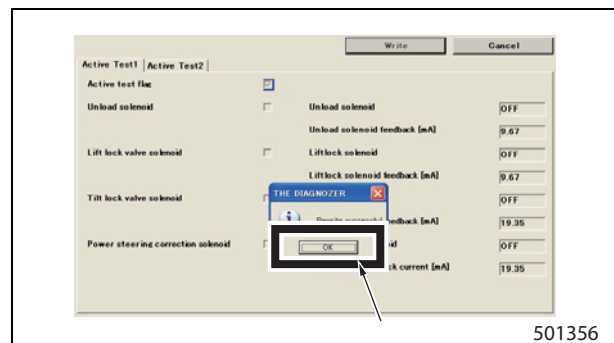

501356

9.2 Seat Switch

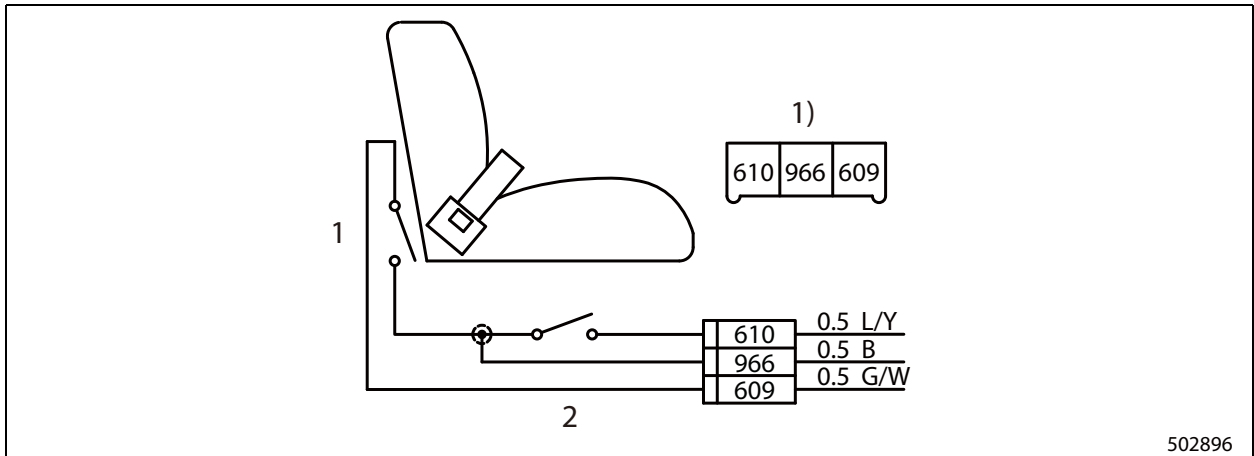

- 1. Seat belt
- 2. Seat switch
- 1) (WHITE)

9.3 Park Brake Switch

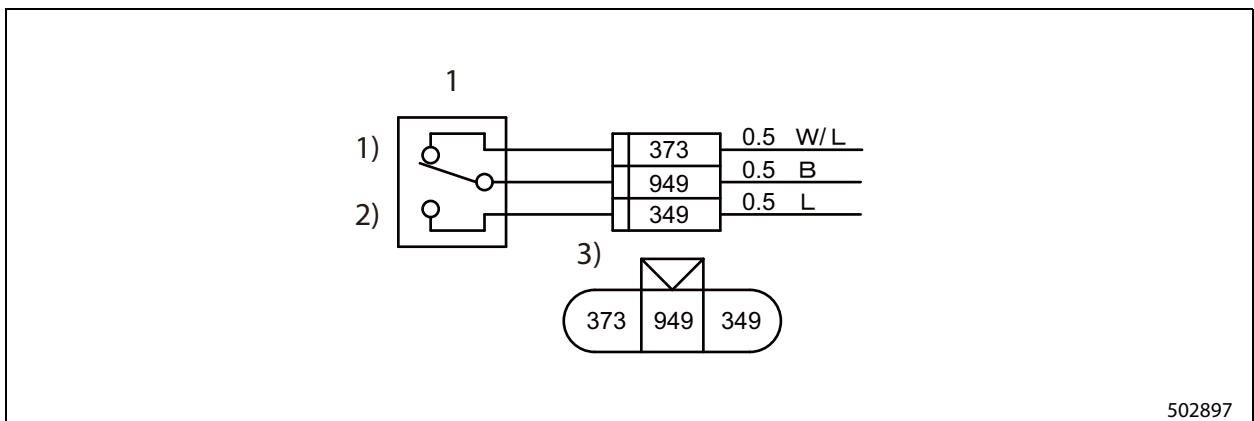

- 1. Park brake switch
- 1) (Release)
- 2) (Lock)
- 3) (BLACK)

9.4 Direction Lever Switch

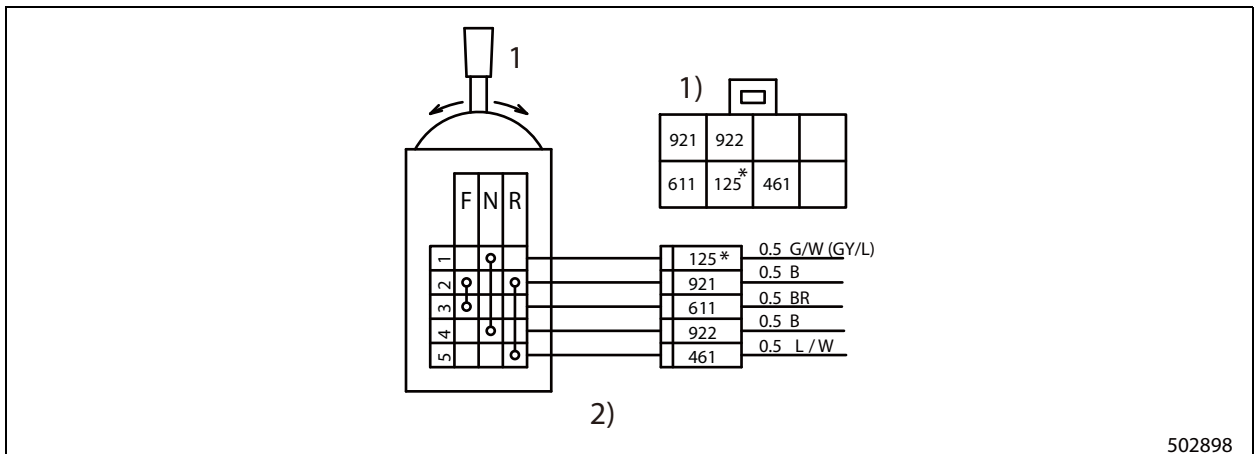

- 1. Direction lever (Shift lever)
- 1) (WHITE)
- 2) *125: gasoline model (GW)
126: diesel model (GY/L)

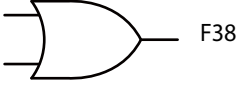
Diagnosis	Tilt angle error warning (F38)	
Logic conditions	<ul style="list-style-type: none"> · Input signal is 0.1V or less (400 ms continuity) · Input signal is 4.9 V or more (400 ms continuity) 	
Recovery	Turn on power again.	
Action	· No tilt action with the tilt auto-stop ON.	
LED blink pattern	D	

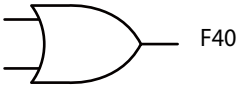
Diagnosis	Steering Warning (F40)	
Logic conditions	<ul style="list-style-type: none"> · 2-second continuous of change for wheel angle sensor. · Steering wheel angle sensor input error 	
Recovery	Turn on power again.	
Action	· No knob deviation correction control.	
LED blink pattern	D	

Diagnosis	Hour meter GAP warning (F73)	
Logic conditions	Hour meter on meter panel or VCM is 24 hour or more, and the hour meter GAP is 24 hour or more.	
Recovery	Update #252 M/P hour meter with service tool.	
Action	<ul style="list-style-type: none"> · VCM sends zero to hour meter. · VCM hour meter is not overwritten. 	
LED blink pattern	E	

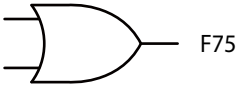
Diagnosis	Unload Solenoid Warning (F75)	
Logic conditions	<ul style="list-style-type: none"> · Current value is 160mA or less (1800 ms continuity) · Input signal is 2.4 A or more (200 ms continuity) 	
Recovery	Turn on power again.	
Action	· Turn OFF the unload solenoid output.	
LED blink pattern	E	

CHAPTER 4 CONTROLLER

Diagnostic code	Diagnostic code name	Probable cause	Check items
S-07	MP Communication warning signal	1. Connector contact bad	1. Connector connection check
		2. Harness bad	2. Harness connection check
		3. Meter panel bad	3. Communication line check
		4. Controller bad	
S-08	TMS communication warning signal	1. Connector contact bad	1. Connector connection check
		2. Harness bad	2. Harness connection check
		3. TMS bad	3. Communication line check
		4. Controller bad	
S-10	APS1 input warning signal	1. Connector contact bad	1. Connector connection check
		2. Harness bad	2. Harness connection check
		3. Accelerator position sensor bad	3. Accelerator position sensor check
		4. Controller bad	
S-11	APS2 input warning signal	1. Connector contact bad	1. Connector connection check
		2. Harness bad	2. Harness connection check
		3. Accelerator position sensor bad	3. Accelerator position sensor check
		4. Controller bad	
S-13	APS1/APS2 relative warning signal	1. Connector contact bad	1. Connector connection check
		2. Harness bad	2. Harness connection check
		3. Accelerator position sensor bad	3. Accelerator position sensor check
		4. Controller bad	
S-14	Idle switch warning signal	1. Connector contact bad	1. Connector connection check
		2. Harness bad	2. Harness connection check
		3. Idle switch bad	3. Idle switch check
S-40	Service brake solenoid warning	1. Connector contact bad	1. Connector connection check
		2. Diode bad	2. Diode connection check
		3. Harness bad	3. Harness connection check
		4. Service brake solenoid bad	4. Service brake solenoid conductivity check
		5. Controller bad	
S-41	Service brake solenoid leak warning	1. Connector contact bad	1. Connector connection check
		2. Diode bad	2. Diode connection check
		3. Harness bad	3. Harness connection check
		4. Service brake solenoid bad	4. Service brake solenoid conductivity check
		5. Controller bad	

CLICK HERE TO **DOWNLOAD** THE COMPLETE MANUAL

- Thank you very much for reading the preview of the manual.
- You can download the complete manual from: www.heydownloads.com by clicking the link below



- Please note: If there is no response to CLICKING the link, please download this PDF first and then click on it.

CLICK HERE TO **DOWNLOAD** THE COMPLETE MANUAL

2.5 Preparation for Removing Pipes and Radiator (Manual T/M Truck)

- (1) Drain the coolant from the radiator by loosening the drain cock at the bottom of the radiator.
- (2) Drain coolant from the engine by removing the drain plug.

2.6 Removal Sequence of Pipes and Radiator (Manual T/M Truck)

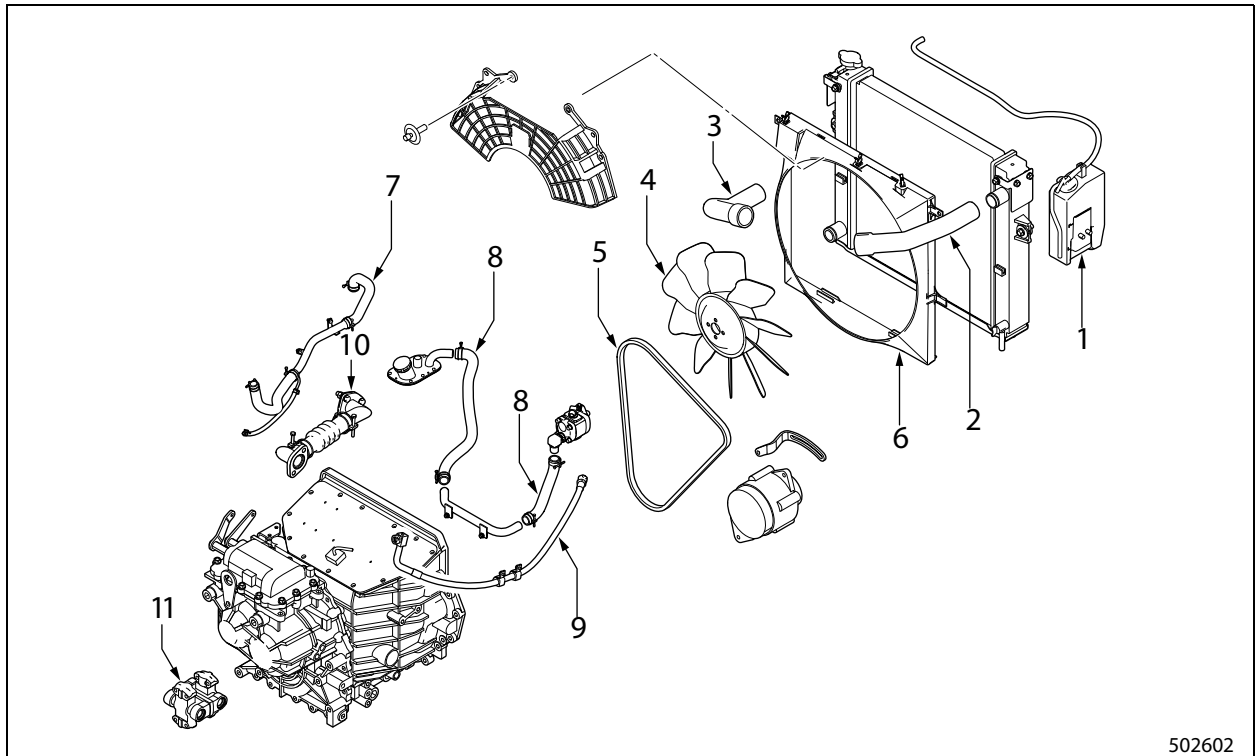

502602

- | | |
|--|---|
| 1. Reserve tank | 8. Hose (between hydraulic tank and oil pump) |
| 2. Hose (upper) | 9. Hose (between oil pump and steering control valve) |
| 3. Hose (lower) | 10. Hose (between transmission and hydraulic tank) (wet-type clutch only) |
| 4. Cooling fan | 11. Universal joint (between transmission and reduction/differential gears) |
| 5. Fan belt | |
| 6. Fan guard | |
| 7. Hose (between hydraulic tank and control valve) | |

2.7 Suggestions for Installing Pipes and Radiator (Manual T/M Truck)

For installation, follow the removal sequence in reverse.

Before connecting hoses to pipes, clean the mating joint surfaces of pipes and hoses.

3. Clutch Assembly, Inspection and Repair After Disassembly

Pressure plate assembly

- Check the friction surface of the pressure plate for burns and striations.
- Check the friction surface of the pressure plate for distortion.

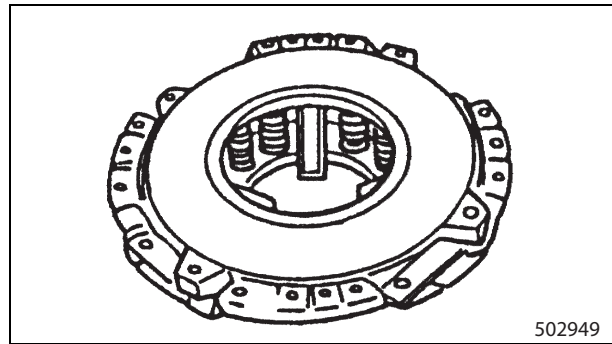

Release bearing

- Check the release bearing for smoothness of rotation with the bearing mounted on the clutch shifter.
- Replace the bearing if it spins rough, makes abnormal noises or its end face in contact with the release levers is badly worn.

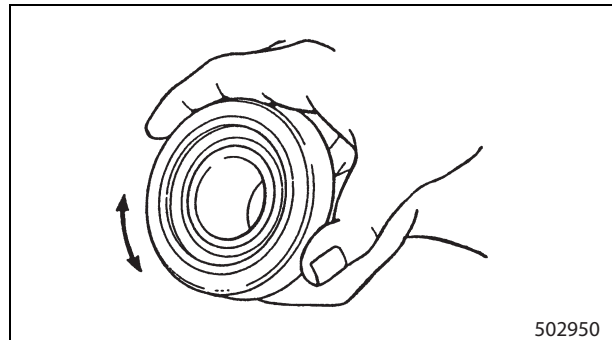

Shifter

Check the fork groove for wear. Ensure the shifter slides smoothly without any sign of binding.

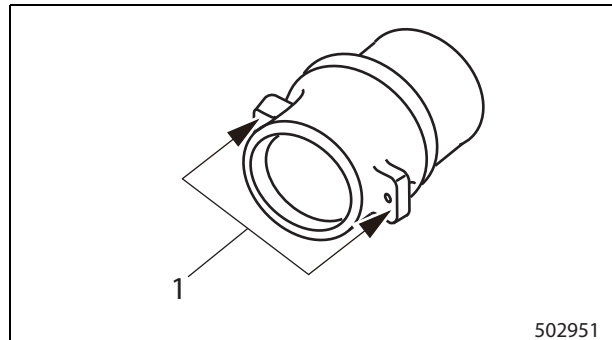

1. Clutch fork groove

Input shaft

- Check for ridged splines.

Flywheel and pilot bearing

- Check the friction surface of the flywheel for burns and striations.
- Check the pilot bearing for wear.

Other parts

- Check the clutch fork and clutch shifter shaft for bend and/or runout.
- Check the needle roller bearing for damage.

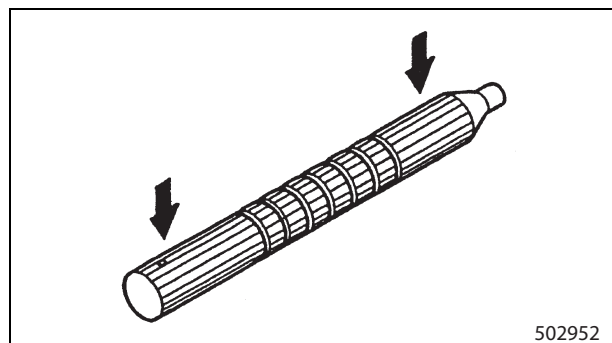

Item	Specified value	
	Release fork, clutch shifter shaft runout	Standard
Limit		0.1 mm (0.004 in.)

Air bleeder valve

- Check the air bleeder valve for damaged or deformed seat. Replace if defective.
- Check the air bleeder valve cap. Replace the air bleeder valve if a significant crack or deterioration is observed.

Push rod

- Check the push rod for bending and deformation. Replace if defective.

Boot

- Check the boot for cracks, damage and tears. Replace if defective.
- Check the boot for interference with the cylinder and push rod. Replace the boot if it has no or little interference.

13. Clutch Release Cylinder, Assembling

For assembly, follow the disassembly sequence in reverse.

13.1 Suggestions for Assembly

- Clean metal parts with a volatile metal cleaning fluid and blow off the fluid completely with compressed air.
- Apply a thin coat of rubber grease (METAL RUBBER #20) or brake oil to the inside surface of cylinder body and the peripheral surface of piston cups. When applying grease, be careful, as the piston seal will swell up if exposed to mineral oil.
- Use care not to allow foreign matter to enter the cylinder body. Also be careful not to damage the cylinder body and the lip of piston cup.
- Tighten the following parts to the specified torque.

Item	Tightening torque
Air bleeder valve	7 to 9N·m (0.7 to 0.9 kgf·m) [5.16 to 6.64 lbf·ft]
Locknut	15 to 17N·m (1.5 to 1.7 kgf·m) [11.06 to 12.54 lbf·ft]

Pressure plate

Item		Specified value	
-	Flatness of plate	Standard	0.05 mm (0.0020 in.) or less
		Limit	0.2 mm (0.008 in.)
1	Thickness of plate (from spring seat to friction surface)	Standard	22.8 mm (0.898 in.)
		Limit	21.0 mm (0.827 in.)
2	Release lever height	Standard	26.5 mm (1.043 in.)
3	Maximum permissible difference between heights of all release levers	Standard	0.7 mm (0.028 in.)
4	Pressure spring	Quantity per clutch	S4Q2,S4S models: 12 pcs K21,K25 models: 10 pcs
		Free length	Standard 78.8 mm (3.102 in.)
		Installed load/installed length	Standard 643 ± 5% N/48.2 mm (1.898 in.)
5	Washer mounting bolt	Tightening torque	39 to 59 N·m (4.0 to 6.0 kgf·m) [28.76 to 43.52 lbf·ft]
6	Lockplate mounting bolts	Tightening torque	5.8 to 7.8 N·m (0.59 to 0.80 kgf·m) [4.278 to 5.753 lbf·ft]
7	Pressure plate	Tightening torque	17 N·m (1.7 kgf·m) [12.54 lbf·ft]

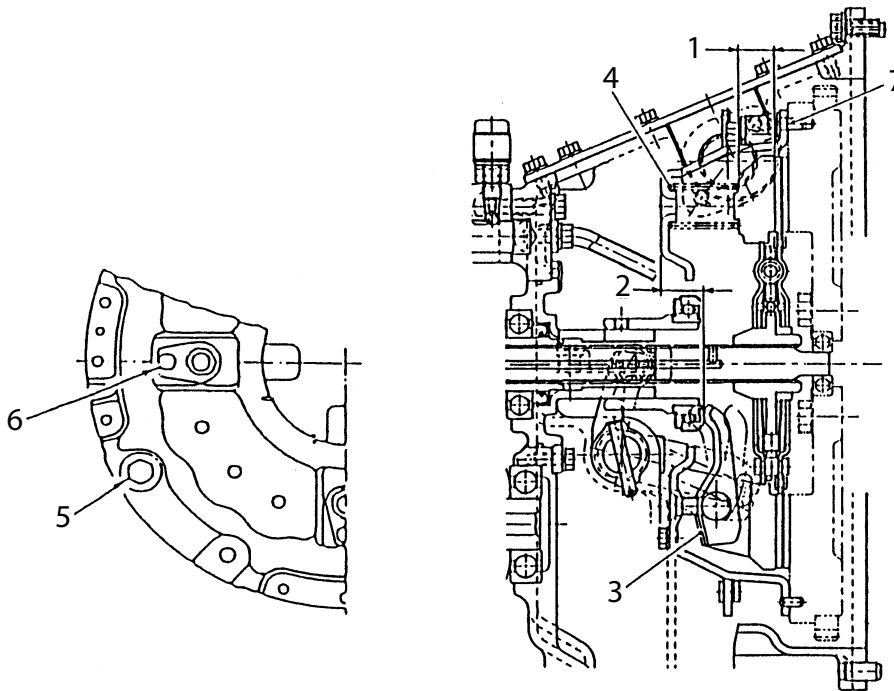

502981

11. Inspection and Repair

Shift fork

Check for bend, cracks, or worn fork tips. If defective, replace.

Shift rail

Check for bend, cracks, or worn ball grooves.

Input shaft

Check for bend, cracks, or worn gear teeth or splines.

Main shaft

- Check for bend, cracks, or worn gear teeth or splines.
- Check the bearings for wear on rolling contact faces.
- Check thrust washers for wear or damage.

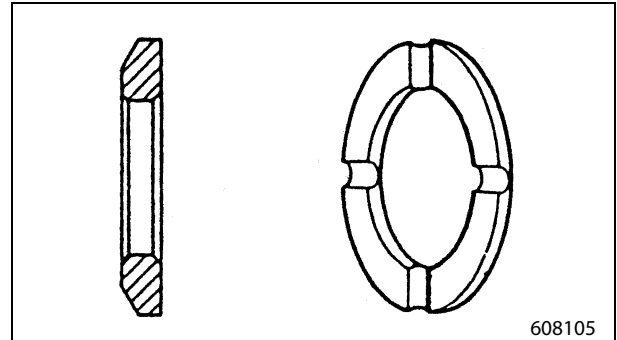

11.1 Synchronesh Device

- (1) Check gears and keys for wear or damage.

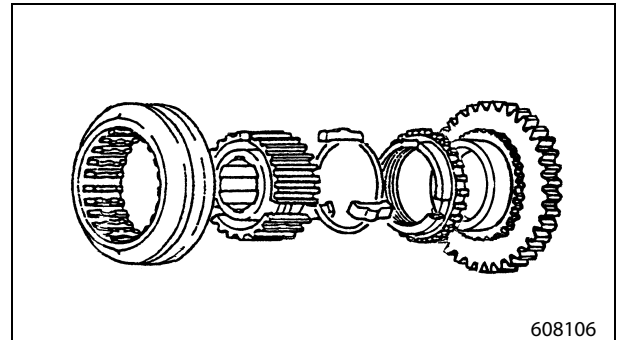

H-L

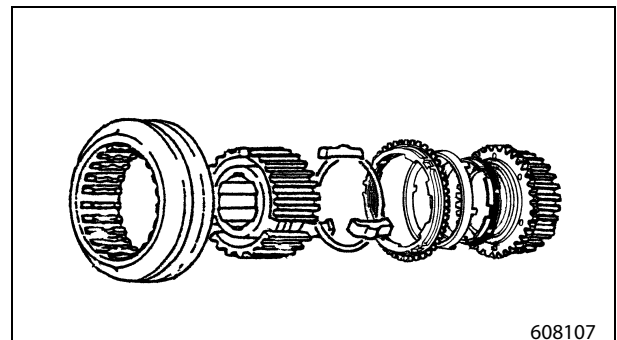

R-F

17.3 Main Shaft

Item		Specified value	
1	Thickness of thrust washer (clutch side)	Standard	4.5 ⁰ _{-0.1} mm (0.177 ^{0.00} _{-0.0004} in.)
2	Thickness of thrust washer (differential side)	Standard	4.5 ⁰ _{-0.1} mm (0.177 ^{0.00} _{-0.0004} in.)
3	Inside diameter of F gear	Standard	55 ^{+0.029} _{+0.010} mm (2.17 ^{+0.0011} _{+0.0004} in.)
4	Outside diameter of F gear sleeve	Standard	50 ^{-0.009} _{-0.020} mm (1.97 ^{-0.0004} _{-0.0008} in.)
5	Inside diameter of R gear	Standard	55 ^{+0.029} _{+0.010} mm (2.17 ^{+0.0011} _{+0.0004} in.)
6	Outside diameter of shaft R gear	Standard	50 ^{-0.009} _{-0.020} mm (1.97 ^{-0.0004} _{-0.0008} in.)
7	Inside diameter of H gear	Standard	55 ^{+0.029} _{+0.010} mm (2.17 ^{+0.0011} _{+0.0004} in.)
8	Outside diameter of H gear sleeve	Standard	50 ^{-0.009} _{-0.020} mm (1.97 ^{-0.0004} _{-0.0008} in.)
9	Inside diameter of L gear	Standard	55 ^{+0.029} _{+0.010} mm (2.17 ^{+0.0011} _{+0.0004} in.)
10	Outside diameter of shaft L gear	Standard	50 ^{-0.009} _{-0.020} mm (1.97 ^{-0.0004} _{-0.0008} in.)

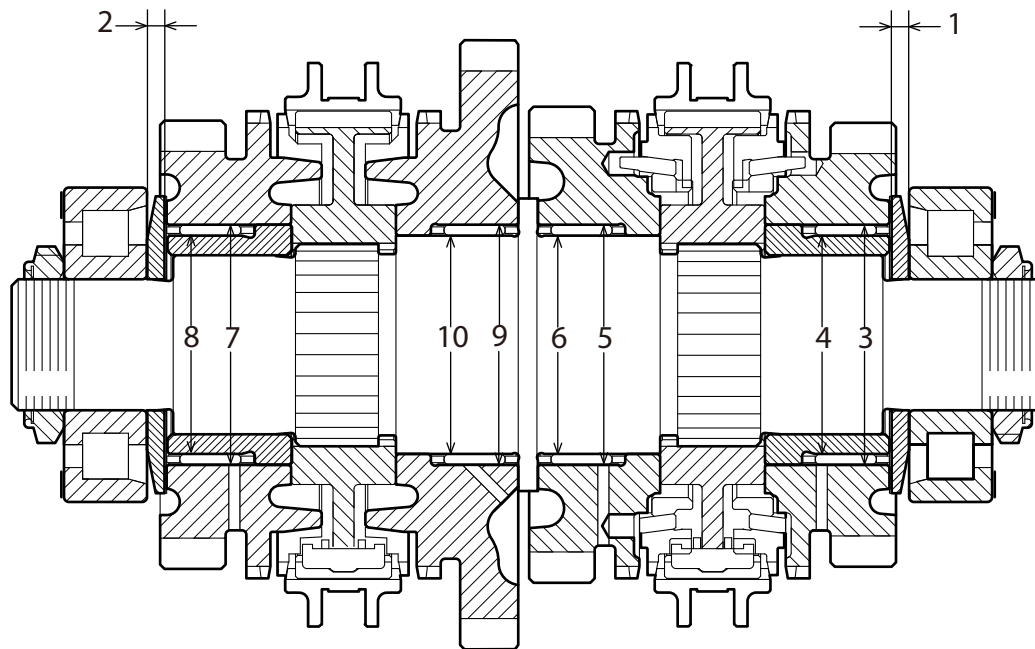

608124

Oil strainer, Removing

Remove oil strainer together with O-ring.

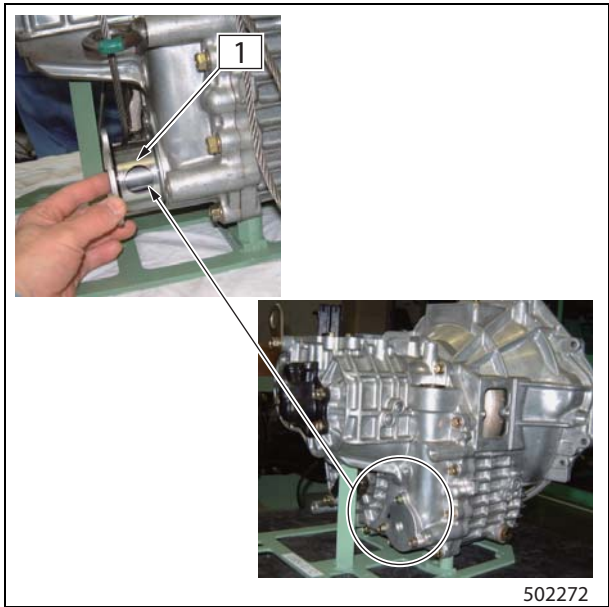

1. Oil strainer assembly

(3) Using puller (special tool), remove bearing together with input spacer.

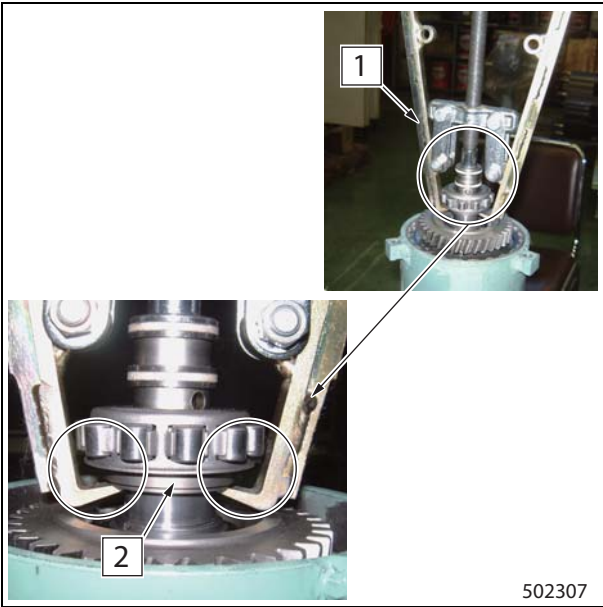

1. Special tool (Puller) 2. Input spacer

Special tool	Part number
Puller	91A68-01800

(4) Remove snapping.

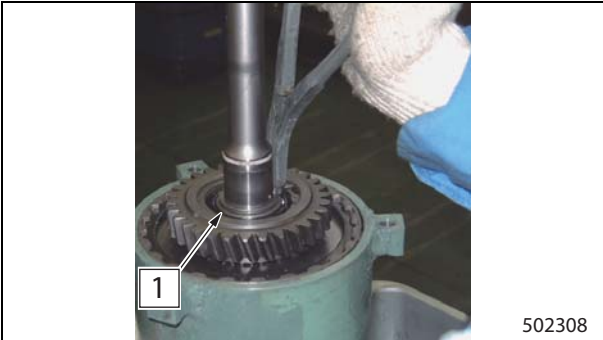

1. Snapping

(5) Pry up the forward gear assembly using a flat head screwdriver.



1. Forward gear

- (6) Install clutch piston using a wood block.
Note: When installing, tap boss of clutch piston.
- (7) Install clutch spring and spring retainer.

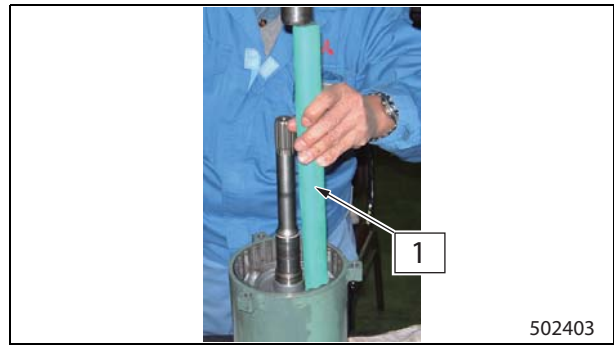

1. Wooden bar

- (8) Compress clutch spring together with spring retainer using stand (special tool, plates 1 and 2).

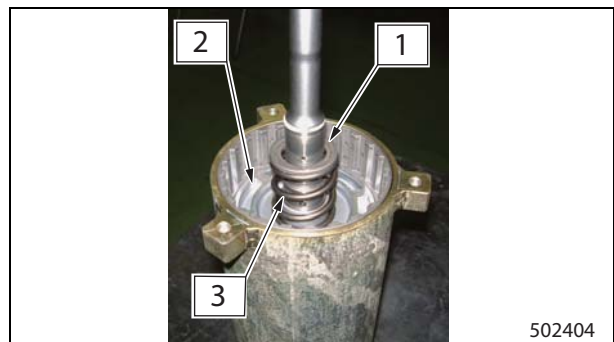

1. Spring retainer
2. Clutch piston

3. Clutch spring

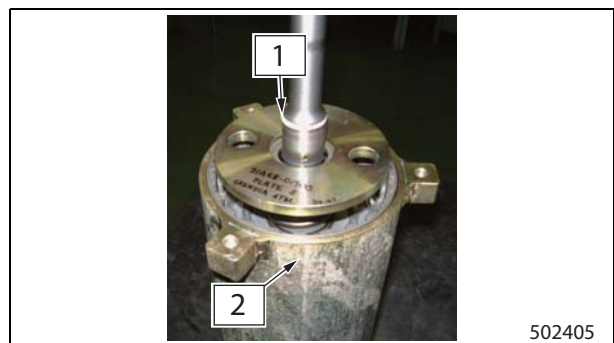

1. Special tool (Plate 2)

2. Special tool (Stand)

Baffle plate, Installing

Install the baffle plate with 2 bolts.

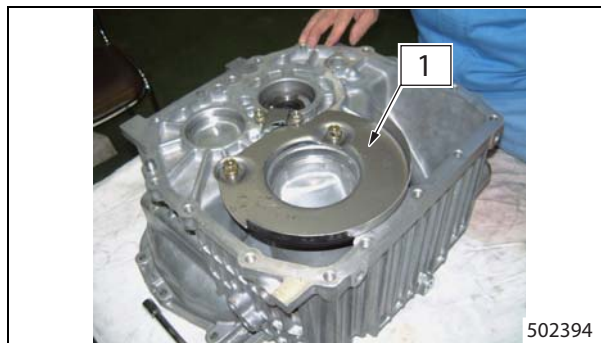

1. Baffle plate

Output gear assembly, Installing

- (1) Place the torque converter housing with its torque converter assembly mounting surface facing down.
- (2) Install output gear assembly to torque converter housing.

Note: The large protruding side should be positioned on the torque converter housing bottom side.

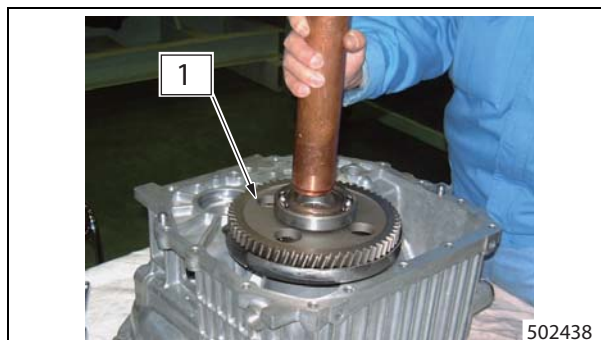

1. Output gear assembly

Input shaft gear assembly and idler gear assembly, Installing

- (1) Tentatively install input shaft gear assembly.



1. Input shaft gear assembly

- (2) Tentatively install idler gear assembly.

Note: The gear having 30 teeth should be on the torque converter housing side and the gear having 32 teeth is on the transmission housing side.

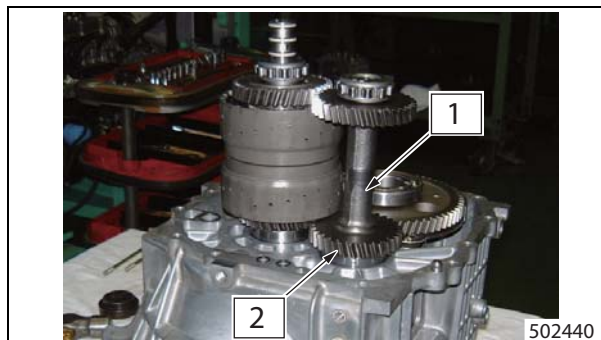

1. Idler gear assembly

2. Z = 30

Regulator valve, Removing

- (1) Remove inner and outer main relief springs.
- (2) Remove the regulator valve together with slug.

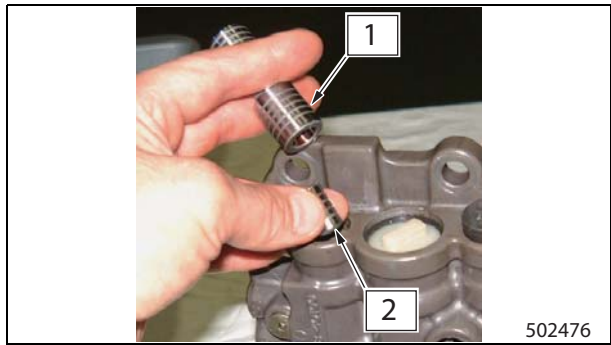

1. Regulator valve 2. Slug

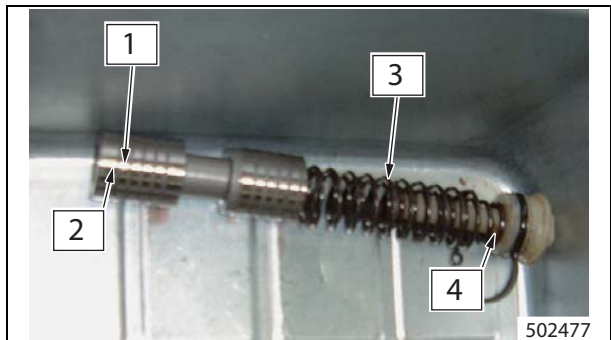

1. Regulator valve 3. Main relief outer spring
2. Slug 4. Main relief inner spring

6.6 Accumulator Valve Section, Disassembling

Accumulator spring seat, Removing

- (1) Remove the snapping from accumulator spring seat.
- Note: When removing the snapping, slowly remove the snapping by pressing it against the accumulator spring seat. Otherwise the accumulator spring seat may pop out.

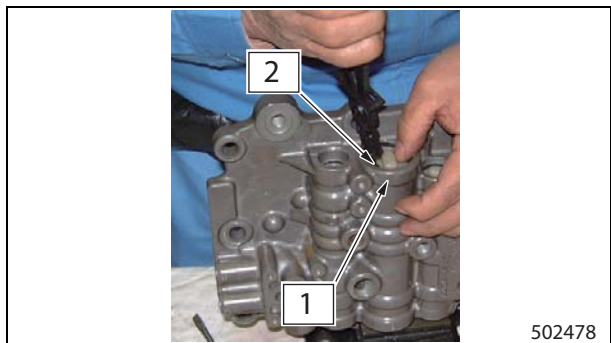

1. Accumulator valve section 2. Snapping

- (2) Remove the accumulator spring seat together with O-ring.

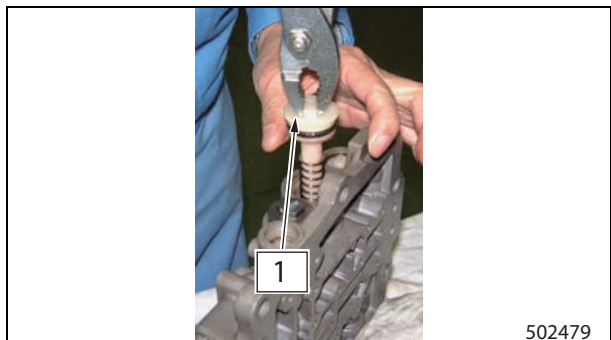

1. Accumulator spring seat

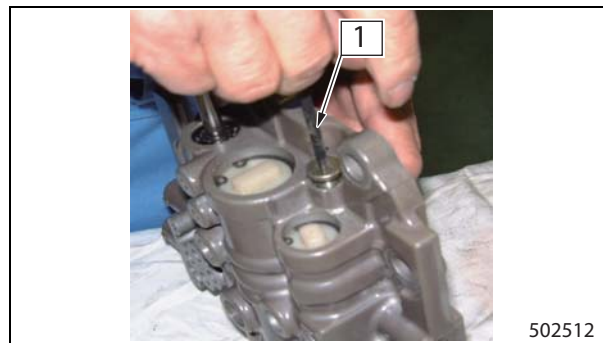

1. Main orifice plug

Ref.	Tightening torque
1	6 to 8 N·m (0.6 to 0.8 kgf·m) [4.43 to 5.90 lbf·ft]

Plug, Installing

- (1) Secure the control valve body in a vise.
- (2) Install O-ring to each plug (seven in total) and install the plugs on the control valve body by tightening to the specified torque.



502513

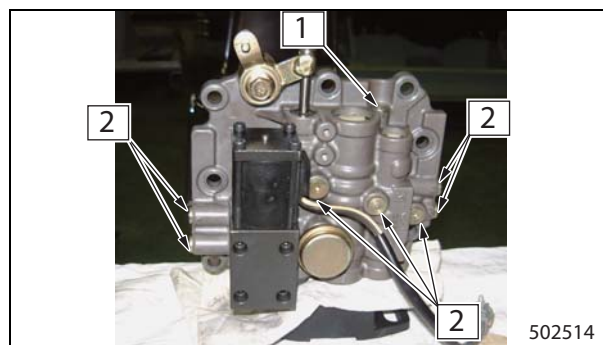

1. Main orifice plug

2. Plug

502514

Ref.	Tightening torque
2	6 to 8 N·m (0.6 to 0.8 kgf·m) [4.43 to 5.90 lbf·ft]

10. Service Data

Item	Specified value	
Main oil pressure, Engine speed at $1600 \pm 100 \text{ min}^{-1}$	Standard	NEUTRAL: $1.25 \pm 0.07 \text{ MPa}$ ($12.75 \pm 0.71 \text{ kgf/cm}^2$) [$181.30 \pm 10.15 \text{ psi}$]
Clutch oil pressure, Engine speed at $1600 \pm 100 \text{ min}^{-1}$	Standard	FORWARD: $1.21 \pm 0.07 \text{ MPa}$ ($12.34 \pm 0.71 \text{ kgf/cm}^2$) [$175.50 \pm 10.15 \text{ psi}$] REVERSE: $1.21 \pm 0.07 \text{ MPa}$ ($12.34 \pm 0.71 \text{ kgf/cm}^2$) [$175.50 \pm 10.15 \text{ psi}$]
T/C inlet oil pressure, Engine speed at $1600 \pm 100 \text{ min}^{-1}$	Standard	NEUTRAL: $0.37 \pm 0.05 \text{ MPa}$ ($3.77 \pm 0.50 \text{ kgf/cm}^2$) [$53.66 \pm 7.25 \text{ psi}$]
Lubrication oil pressure, Engine speed at $1600 \pm 100 \text{ min}^{-1}$	Standard	NEUTRAL: $0.08 \pm 0.03 \text{ MPa}$ ($0.82 \pm 0.30 \text{ kgf/cm}^2$) [$11.60 \pm 4.35 \text{ psi}$]
10 m (10.9 yd) acceleration (empty load)	Standard	5 seconds or less
Stall speed in theory	Standard	K21: $1930 \pm 100 \text{ min}^{-1}$
	Standard	K25: $2008 \pm 100 \text{ min}^{-1}$
	Standard	S4Q2: $2550 \pm 100 \text{ min}^{-1}$
	Standard	S4S: $2100 \pm 100 \text{ min}^{-1}$

10.1 Pump Boss

Ref.	Item	Specified value	
1	Oil seal contact surface (outside diameter)	Standard	$42^{+0.035}_{-0.085} \text{ mm}$ ($1.654^{+0.0014}_{-0.0033} \text{ in.}$)
		Limit	41.85 mm (1.6476 in.)

502530

7.3 Suggestions for Disassembly

- (1) Locknut, removing
Use locknut wrench (special tool).

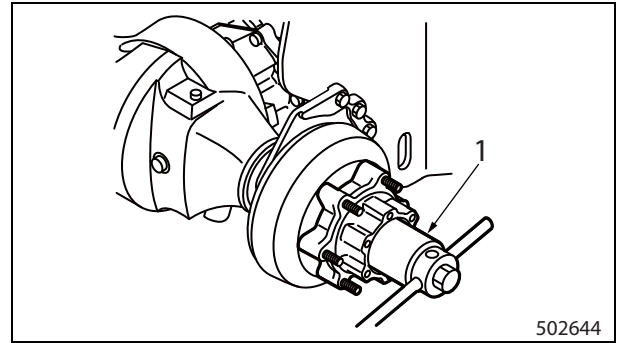

1. Special tool

Special tool	Tool number
1 ton class	91A67-00300
2, 3 ton classes	03703-59001

- (2) Front wheel hub, removing
Use wheel hub puller (special tool) to remove front wheel hub.

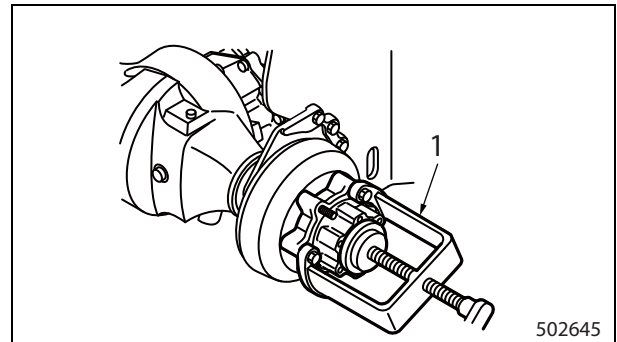

1. Special tool

Special tool	Tool number
1 ton class	64309-40100 (64309-10601)
2, 3 ton classes	MH061017

Note: You do not have to remove oil seal from the hub unless seal is defective.

- (3) Bearing, removing
The inner race of the tapered roller bearing that remains in the axle housing should be removed together with seal retainer using bearing puller.

Note: Seal retainers are not equipped in 1 ton class trucks.

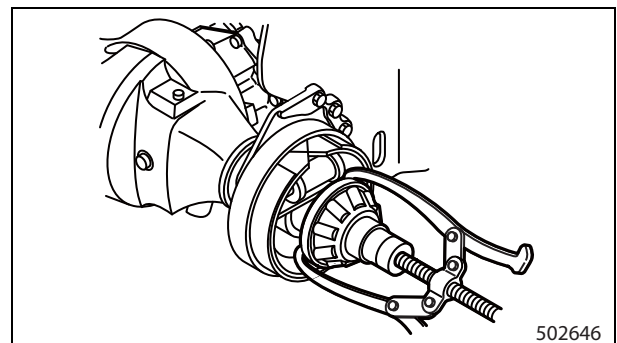

Adjusting preload of reduction pinion

- After the tapered roller bearing is installed, measure gap between the differential cover and tapered roller bearing to determine the required total shim thickness. The standard value of total shim thickness is 1.25 mm (0.0492 in.).
- Select the proper shim according to the measurement, and tighten the nut. Five different thicknesses of shims are available: 0.05 mm (0.0020 in.), 0.1 mm (0.004 in.), 0.2 mm (0.008 in.), 0.5 mm (0.020 in.) and 1.0 mm (0.039 in.).

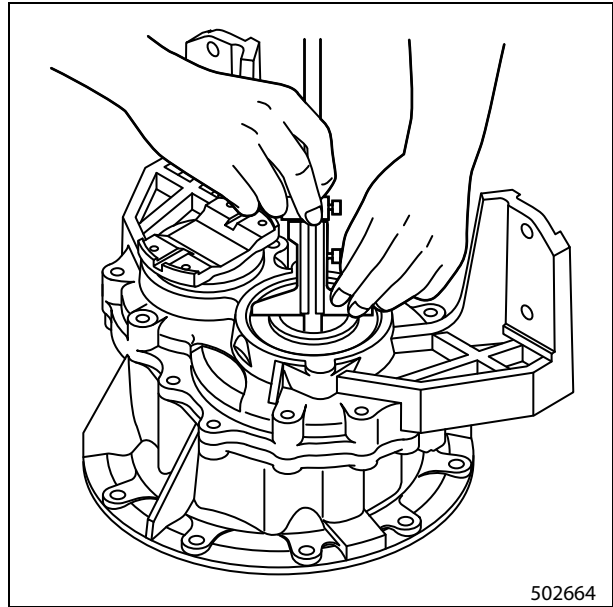

- Hook a spring scale onto the bolt hole of the input flange, and pull it in the tangential direction. Read the force to start moving to measure the preload of tapered roller bearing. Increase or decrease shims until specified tangential force is obtained.

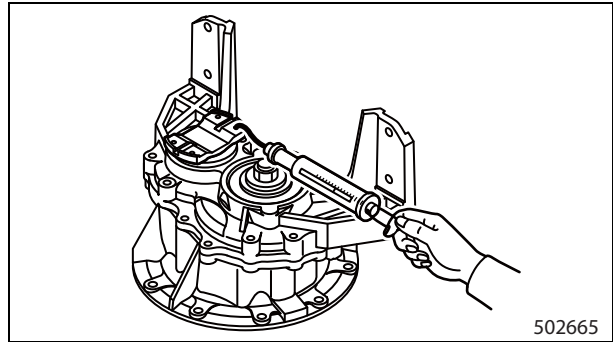

Item	Standard
Tangential force (spring scale reading)	34.3 to 49.0 N (3.50 to 5.00 kgf) [7.711 to 11.016 lbf]

Tightening bearing caps

After reduction gear tooth contact inspection, tighten bearing cap bolts to the specified torque, and bend the lockplate to clinch the bearing cap.

Item	Standard	
Bearing cap tightening torque	1 ton class	157 ± 5.9 N·m (0.60 kgf·m) [4.352 lbf·ft]
	2, 3 ton classes	235 ± 6.8 N·m (0.69 kgf·m) [5.015 lbf·ft]

6. Axle Assembly, Installing

For installation, follow the removal sequence in reverse and observe the instructions below:

- (1) Using shims, adjust the total front and back clearance to be 0.8 mm (0.032 in.) or less.

⚠ CAUTION

Place shims equally at the front and back.

- (2) Apply "AUTOLEX A" grease or equivalent through grease nipple.
- (3) Tighten the bolts to the specified torque.

Item	Specified value
Tightening torque	247.4 to 334.8 N·m (25.23 to 34.14 kgf·m) [182.473 to 246.936 lbf·ft]

7. Wheel Hub, Disassembling

7.1 Disassembly Sequence

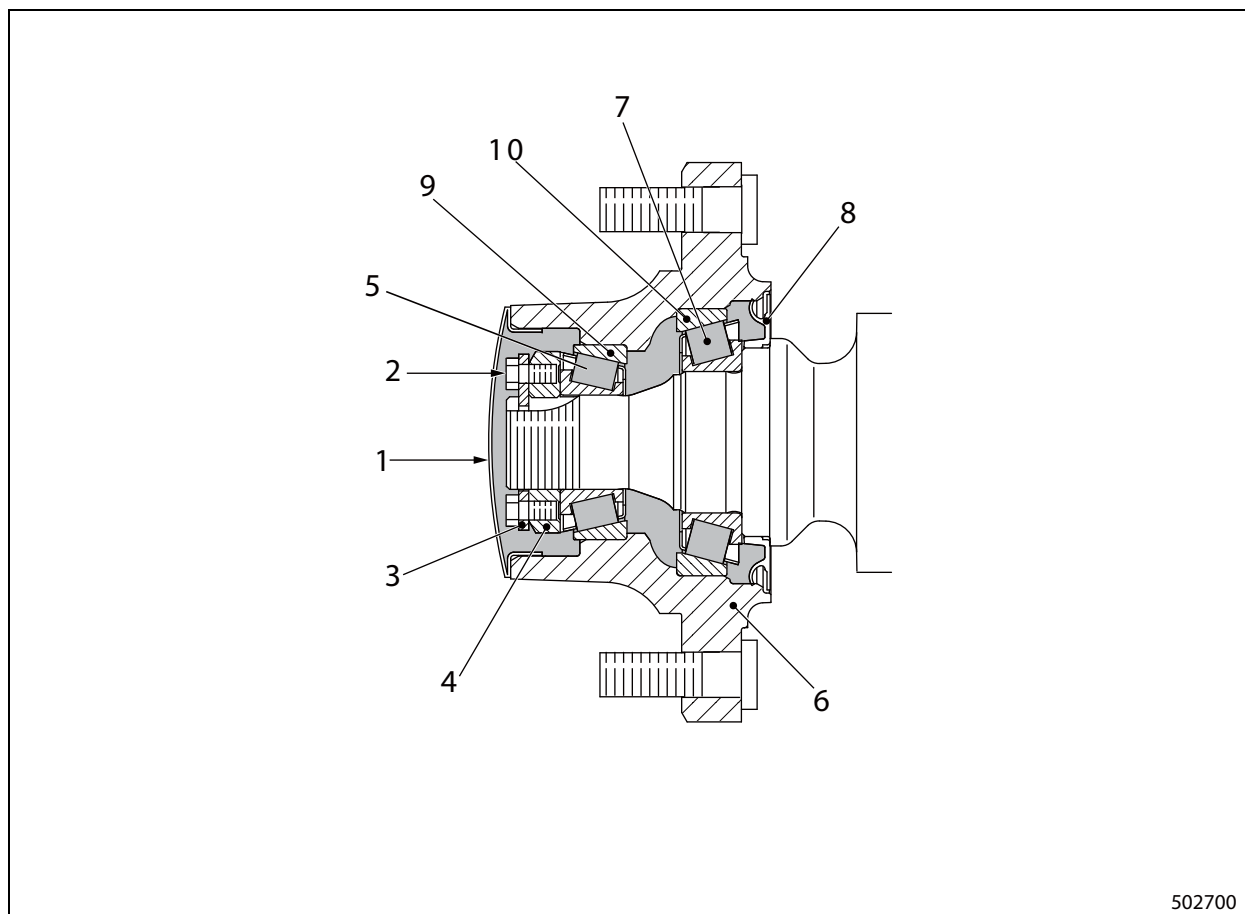

- | | |
|--|---|
| 1. Hub cap | 6. Hub (with tapered roller bearing outer race) |
| 2. Bolt | 7. Tapered roller bearing (inner race) |
| 3. Lockplate | 8. Oil seal |
| 4. Locknut (hexagon nut) | 9. Tapered roller bearing (outer race) |
| 5. Tapered roller bearing (inner race) | 10. Tapered roller bearing (outer race) |

5.2 2, 3 Ton Classes

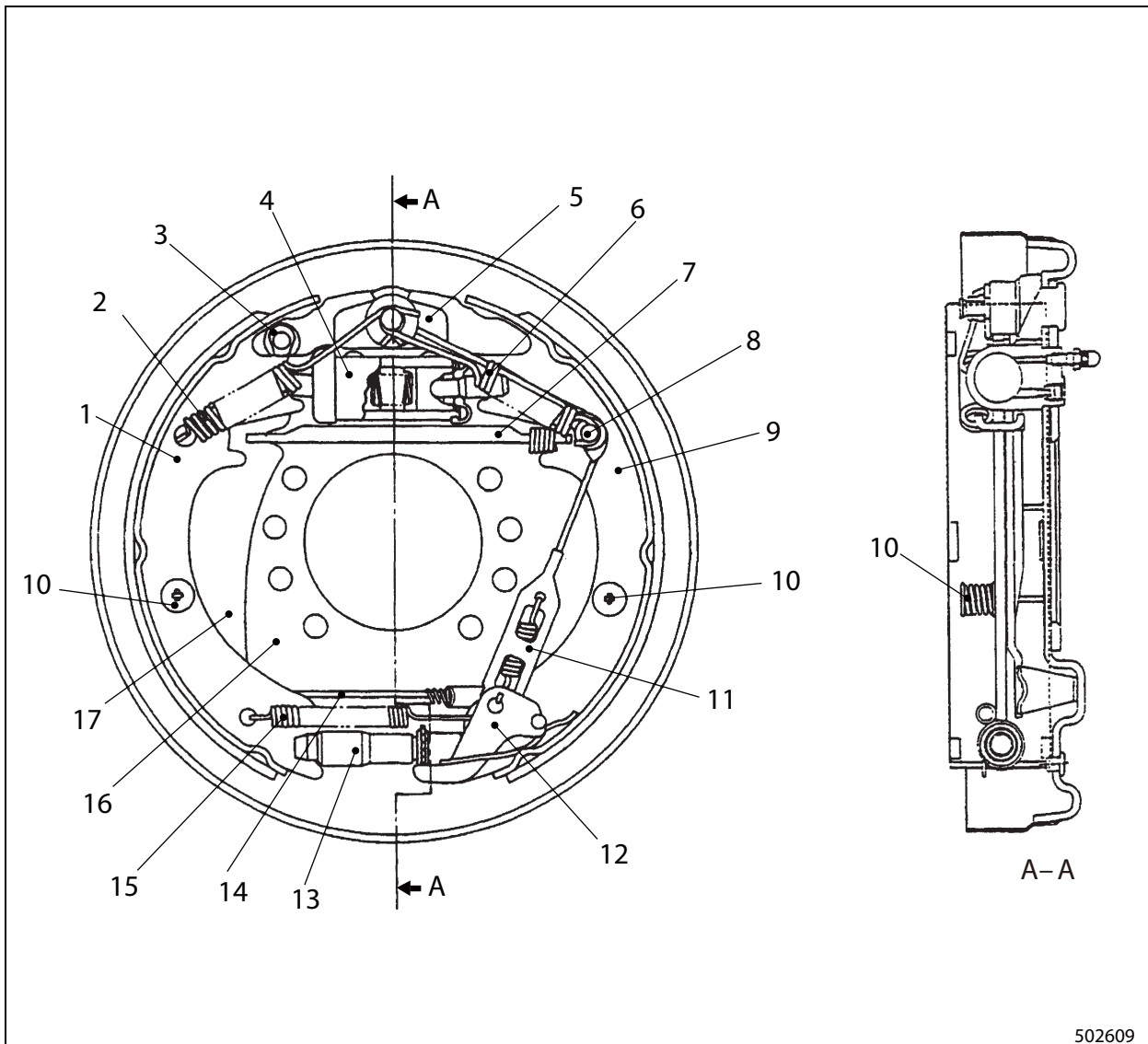

502609

- | | |
|---|---|
| <ul style="list-style-type: none"> 1. Primary shoe and lining assembly 2. Return spring (primary) 3. Retainer, Washer 4. Wheel cylinder 5. Shoe guide plate 6. Return spring (secondary) 7. Strut, Anti-rattle spring 8. Pin, Sheave, Washer 9. Secondary shoe and lining assembly | <ul style="list-style-type: none"> 10. Pin, Hold-down spring, Cup 11. Fitting link 12. Adjusting lever, Adjusting spring 13. Adjusting screw 14. Parking brake cable, Snapping 15. Return spring (between primary shoe and secondary shoe) 16. Backing plate assembly 17. Parking brake lever |
|---|---|

Note: Shown in the figure is for the left.

12.5 Brake Oil Line, Bleeding

If any portion of the brake oil lines has been disassembled for repair or service, or if the brake pedal feels spongy, bleed the lines as follows:

- (1) Install one end of a transparent vinyl tube onto the bleeder screw of the right hand side wheel cylinder, which is located farther from the master cylinder than the left hand wheel cylinder. Put the other end of the tube into a container filled with brake oil.
- (2) Check the brake oil level in the reserve tank. Fill up as necessary.
- (3) Press the pedal several times, and with the pedal pressed all the way down, loosen the bleeder screw. While the brake oil is flowing through the tube, tighten the bleeder screw.
- (4) Repeat the step above until the brake oil flowing through the tube is free of air bubbles. Bleed air from left side wheel cylinder as well, by following the above procedures.
When brake oil is completely free of air bubbles, add brake oil into the reserve tank to the specified level.

Note:

- Make sure the brake oil reserve tank does not run empty.
- Use only the brake oil of specified brand and grade. Do not intermix different types of brake oil.

12.6 Braking Performance Test

When brake system maintenance is completed, conduct braking tests at a speed of 10 km/h (6.2 mph). Re-adjust as necessary by referring to 11-15 "Manual Adjustment Procedure".

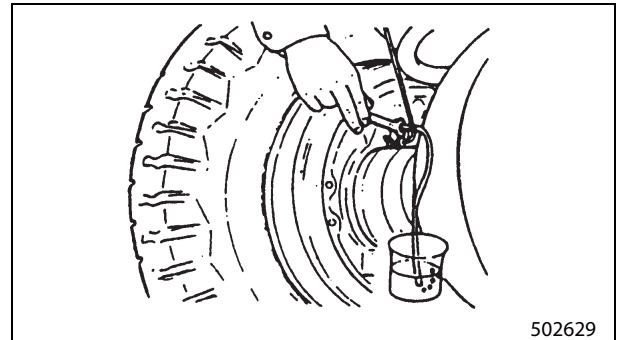

4. Steering Wheel and Steering Valve, Installing

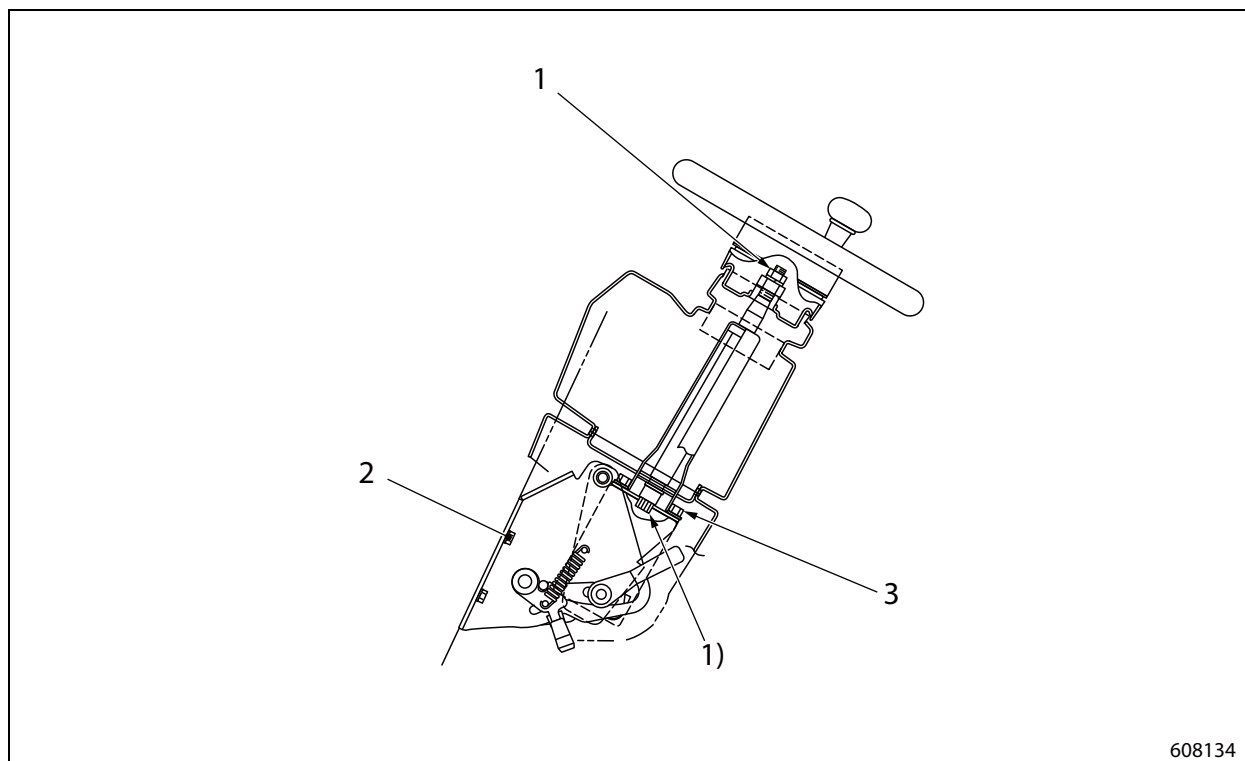

1) Apply grease.

Ref.	Item	Tightening torque
1	Steering wheel nut	58.5 ± 5.9 N·m (5.97 ± 0.60 kgf·m) [43.147 ± 4.35 lbf·ft]
2	Steering column assembly	33.3 ± 6.7 N·m (3.40 ± 0.68 kgf·m) [24.561 ± 4.94 lbf·ft]
3	Steering valve mounting bolt	39 ± 5 N·m (4.0 ± 0.50 kgf·m) [28.76 ± 3.68 lbf·ft]

14. Service Data

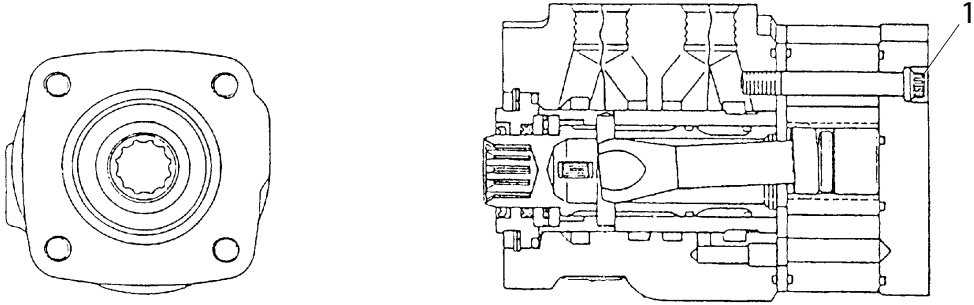
Item		Specified value			
Steering effort (at steering wheel rim)		Standard	13 N (1.3 kgf) [2.92 lbf] or less	13 N (1.3 kgf) [2.92 lbf] or less	13 N (1.3 kgf) [2.92 lbf] or less
Steering wheel mounting nut		Tightening torque	58.5 ± 5.9 N·m (0.60 kgf·m) [4.352 lbf·ft]	58.5 ± 5.9 N·m (0.60 kgf·m) [4.352 lbf·ft]	58.5 ± 5.9 N·m (0.60 kgf·m) [4.352 lbf·ft]
Steering bracket bolt		Tightening torque	26.7 to 39.9 N·m (2.72 to 4.07 kgf·m) [19.693 to 29.429 lbf·ft]	26.7 to 39.9 N·m (2.72 to 4.07 kgf·m) [19.693 to 29.429 lbf·ft]	26.7 to 39.9 N·m (2.72 to 4.07 kgf·m) [19.693 to 29.429 lbf·ft]
Steering valve mounting bolt		Tightening torque	39 ± 5 N·m (0.5 kgf·m) [3.69 lbf·ft]	39 ± 5 N·m (0.5 kgf·m) [3.69 lbf·ft]	39 ± 5 N·m (0.5 kgf·m) [3.69 lbf·ft]
Steering valve	Displacement volume	Standard	96 cm ³ (5.85 cu in.)/rev	96 cm ³ (5.85 cu in.)/rev	96 cm ³ (5.85 cu in.)/rev
	Rotating torque in normal steering	Standard	1.5 N·m (0.15 kgf·m) [1.106 lbf·ft]	1.5 N·m (0.15 kgf·m) [1.106 lbf·ft]	1.5 N·m (0.15 kgf·m) [1.106 lbf·ft]
	1 End cap mounting bolt	Tightening torque	23 N·m (2.3 kgf·m) [16.96 lbf·ft]	23 N·m (2.3 kgf·m) [16.96 lbf·ft]	23 N·m (2.3 kgf·m) [16.96 lbf·ft]
Steering system relief valve set pressure		Standard	8.8 ^{+0.5} / ₀ MPa (89.74 ^{+5.10} / _{0.00} kgf/cm ²) [1276.33 ^{+72.52} / _{0.00} psi]	10.3 ^{+0.5} / ₀ MPa (105.03 ^{+5.10} / _{0.00} kgf/cm ²) [1493.89 ^{+72.52} / _{0.00} psi]	10.3 ^{+0.5} / ₀ MPa (105.03 ^{+5.10} / _{0.00} kgf/cm ²) [1493.89 ^{+72.52} / _{0.00} psi]
					
608157					

Movement during piston descent

The figure on the right shows the movement of the cushion spool 6 when the piston descends. (To the right of the figure is the bottom of the cylinder.)

- (1) This figure shows the position of the cushion spool 6 before it contacts the cylinder bottom. The cushion spool 6 is extended by the spring 8.

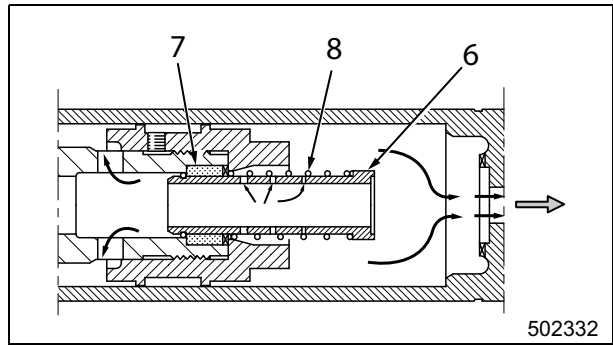

- (2) This figure shows a condition in which cushion spool 6 is in contact with the cylinder bottom and slightly moves into check valve 7. The check valve moves to the left, blocking area 1). Oil 2) trapped below the piston is discharged through holes (two rows on the right) of the cushion spool 6. For check valve shape, see the figure on the next page.

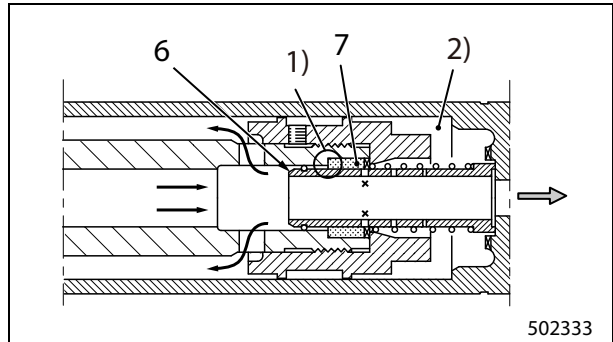

- (3) As the piston descends further, cushion spool 6 moves into the check valve further. As a result, the number of escape holes are decreased and the discharge of trapped oil 2) is restricted. The descending speed of the piston becomes slower, thereby collision is avoided.

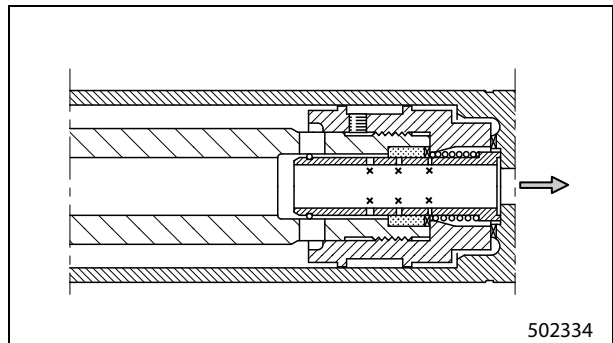

13. Lift Cylinders, Assembling (First Cylinder for Duplex and Triplex Masts)

For assembly, follow the disassembly sequence in reverse.

13.1 Suggestions for Assembly

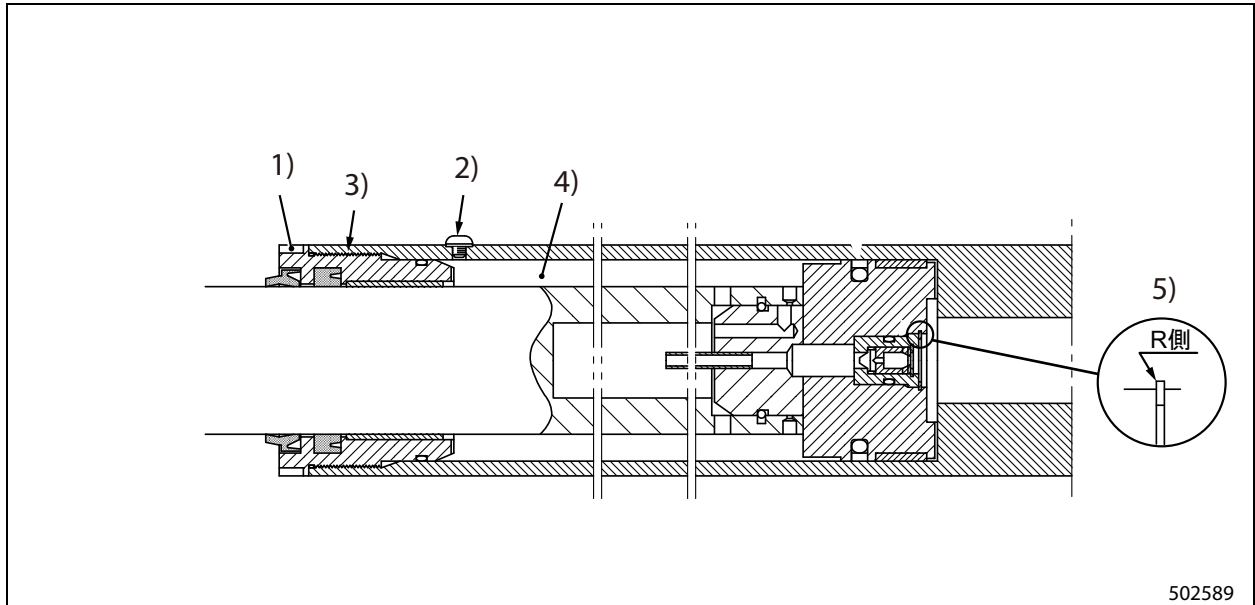

- | | |
|---|---|
| <p>1) Tightening torque:
1, 2 ton class cylinder:
382 N·m (39.0 kgf·m) [281.75 lbf·ft] (M75 x 2)
3 ton class cylinder:
490 N·m (49.97 kgf·m) [361 lbf·ft] (M90 x 2)
3.5 ton class cylinder:
530 N·m (54.04 kgf·m) [390 lbf·ft] (M95 x 2)</p> <p>2) Tightening torque: 3.92 N·m (0.400 kgf·m) [2.8912 lbf·ft]</p> <p>3) Apply ThreeBond 1901 when installing</p> | <p>4) Cushion oil (hydraulic oil) refill capacity
1, 2 ton class cylinder: 75 to 85 cc (4.6 to 5.2 cu. in.)
3 ton class cylinder: 90 to 100 cc (5.56 to 6.1 cu. in.)
3.5 ton class cylinder: 160 to 180 cc (9.8 to 11.0 cu. in.)</p> <p>5) R side</p> |
|---|---|

- (1) Clean parts that have been disassembled with a cleaning solvent. Blow off foreign materials such as dust with compressed air. Do not apply compressed air to rubber parts.
- (2) Apply a clean coat of hydraulic oil to every sliding surface and sealing surface.
- (3) Pay attention to the orientation when installing the check valve snapper.
- (4) Before installing the cylinder head, fill the space between the tube and rod with the specified amount of hydraulic oil as cushion oil.
- (5) Tighten the cylinder head to the specified torque.

Item		Cylinder head tightening torque	Cylinder head thread size
Duplex mast	1, 2 ton classes	382 N·m (39.0 kgf·m) [281.75 lbf·ft]	M75 x 2
	2.5 ton class	422 N·m (43.0 kgf·m) [311.25 lbf·ft]	M80 x 2
	3 ton class	490 N·m (50.0 kgf·m) [361.41 lbf·ft]	M90 x 2
	3.5 ton class	530 N·m (54.0 kgf·m) [390.91 lbf·ft]	M95 x 2
Triplex mast	1, 2 ton classes	382 ± 87.3 N·m (39.0 ± 8.90 kgf·m) [281.75 ± 64.38 lbf·ft]	M75 x 2
	2.5 ton class	422 ± 96.1 N·m (43.0 ± 9.79 kgf·m) [311.25 ± 70.87 lbf·ft]	M80 x 2
	3 ton class	490 ± 113 N·m (50.0 ± 11.52 kgf·m) [361.41 ± 83.34 lbf·ft]	M90 x 2
	3.5 ton class	530 ± 122 N·m (54.0 ± 12.44 kgf·m) [390.91 ± 89.98 lbf·ft]	M95 x 2

29. Inspection and Adjustment

29.1 Hydraulic Tank, Inspecting and Adjusting

Oil daily inspection

Check oil level and check oil for contamination and white turbidity (air and water intrusion).

Proper oil level

Check oil level with the mast fully lowered.

Filling hydraulic tank with oil

For recommended oil, refer to CHAPTER "SERVICE DATA".

- (1) With the mast fully lowered, fill the hydraulic tank with oil.
- (2) Move the mast up and down, and repeat this several times, and then lower the mast.
- (3) Check oil level with the level gauge. If oil level is low, add oil.

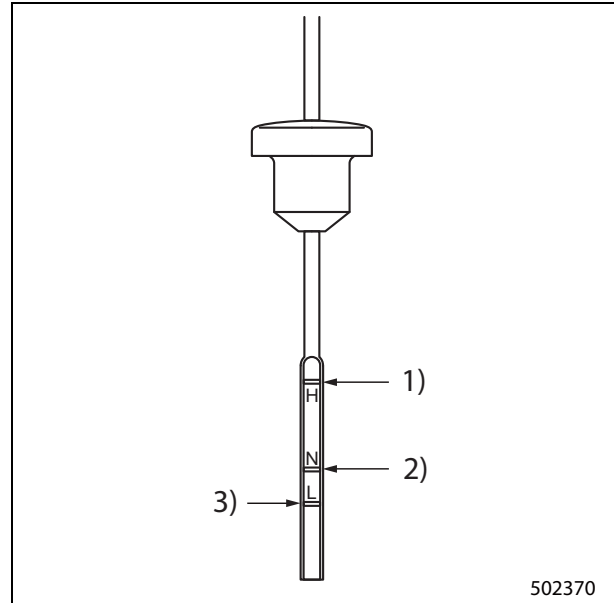

502370

- 1) Maximum level for triplex mast 3) Minimum level
 2) Maximum level for simplex mast

⚠ CAUTION

Oil level in the tank must not exceed H level when the mast is lowered, regardless of any combination of mast and attachment.

Inspecting suction strainer

Check for damage and clogging. Wash if contaminated.

Inspecting return filter

Check for damage. The filter requires periodic replacements. Replace if replacement interval has been reached. Refer to 13-38 "Suction Strainer and Return Filter, Removing".

29.2 Control Valve, Inspecting

External oil leak

- (1) Check for oil leaks from the joint between adjacent valve housings sealed with O-ring.
- (2) Check for oil leaks from threaded connections.

Valve internal oil leak

To check oil leaks of the control valve, connect the control valve to each cylinder for inspection. Follow Steps (1) to (3) described below for inspection.

Note that measured value is the total amount of leaks from lift spool, tilt spool, tilt lock valve, and check valves.

(Oil temperature for measurement: 50°C [122°F])

- (1) Place a load equal to the rated capacity on the forks, and lift the forks approximately 1 m (3.28 in.) high. Tilt the mast about 3° to 4° forward from the vertical position, and turn the engine OFF.

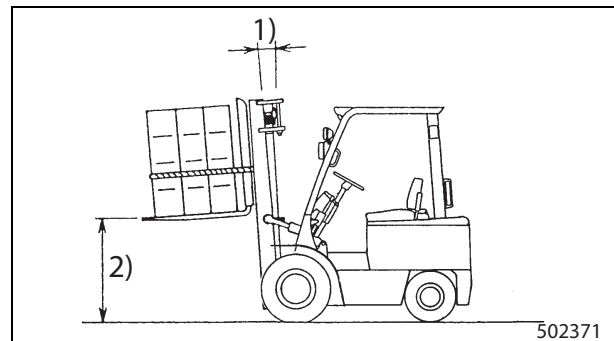

502371

1) 3 to 4°

2) Approx. 1 m (39.4 in.)

32.2 Inlet Cover Section

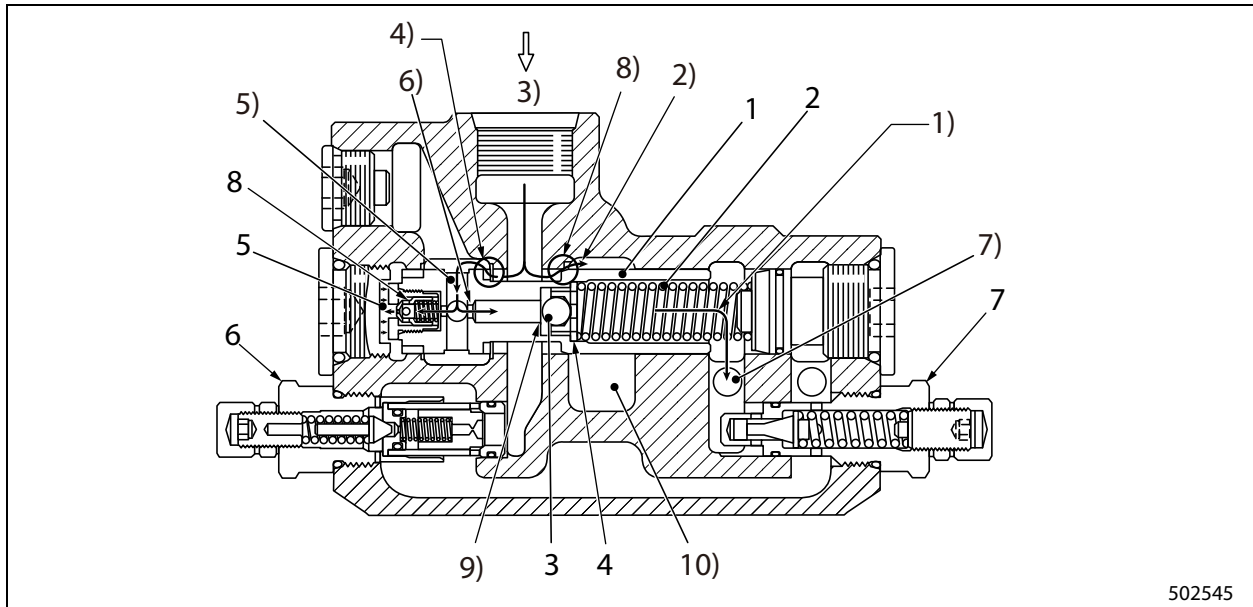

- | | |
|---|--|
| 1. Priority valve spool | 2) Excess flow (EF flow) |
| 2. Spring | 3) P: From hydraulic pump (pump port) |
| 3. Ball check | 4) PF: Restricted area |
| 4. Ball retainer | 5) Hole A |
| 5. Damper chamber | 6) Control orifice |
| 6. Main relief valve | 7) PF: To steering valve (priority port) |
| 7. Steering system relief valve (PF relief valve) | 8) EF: Restricted area |
| 8. Valve | 9) Ball check seat face |
| 1) Priority flow (PF flow) | 10) Excess flow passage (EF flow) |

The inlet section of the control valve consists of the main relief valve 6, which limits the maximum pressure of the hydraulic system. The priority valve which feeds the pressure oil preferentially to the steering system, and the steering system relief valve 7, which limits maximum pressure of the supplied pressure oil.

The priority valve is a flow divider valve which divides supplied oil to a predetermined volume of priority flow (PF flow) and excess flow (EF flow). PF flow is supplied to the steering system and EF flow to the load valves, respectively.

The figure above shows the position of priority valve spool 1 during operation (pump rotation).

Priority flow that enters port P will be as follows: PF restricted area Hole (A) Control orifice Groove between Ball check 3 and Ball retainer 4 Spring chamber PF port.

This passage is always open and a certain volume of oil is flowing toward the steering valve during the engine is running.

Excess flow enters EF port through EF restricted area and goes into the center bypass port of load valve.

When the flow volume from pump to port P is increased, PF flow passing through the control orifice is also increased. Then, differential pressure across the orifice becomes greater.

Hydraulic pressure before the control orifice, namely pump pressure, acts on the left edge of valve spool 1 and PF flow pressure acts on the right edge face of the spool.

Therefore, when differential pressure becomes greater, the valve moves to the right, closes PF restricted area and opens EF restricted area, releasing excess flow to the EF port. As a result, PF flow decreases and so does the differential pressure.

On the other hand, when oil flow volume into port P decreases, PF flow through the control orifice decreases and so does the differential pressure. The spool moves to the left and restricts excess flow. As a result, PF flow increases and so does the differential pressure.

Differential pressure between excess flow and PF flow will vary not only by flow volume but also by operation of forks. Differential pressure across the control orifice is maintained constant by adjusting the opening angles of PF and EF restricted areas.

As differential pressure is constant, PF flow becomes constant.

40. Control Valve - End Cover Section, Assembling

For assembly, follow the disassembly sequence in reverse.

40.1 Suggestions for Assembly

- (1) Clean parts that have been disassembled with an appropriate solvent, and apply compressed air to the parts to dry and remove foreign matter.
- (2) Apply hydraulic oil to each part.
- (3) Replace O-rings with new ones.
- (4) Tighten tie bolts.
Tighten bolts evenly. Tightening them unevenly or to inadequate torque can distort the valve body, resulting in unsmooth movement of the spool.
- (5) Install component valves after appropriate valve bodies are installed with tie bolts.
- (6) Ensure the spools slide smoothly.

Note: The valve body and spool have been lapped as a set. Do not change the combination. When replacing, replace as a set of body and spool.

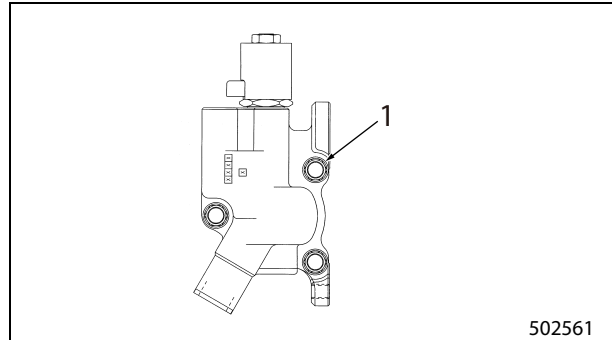

1. Tie bolt

Adjusting clearance between middle roller side face and thrust plate

Note: The following adjustment is not required for upper rollers.

Measure the clearance between middle roller side face and thrust plate. If the measured clearance does not meet the standard value, adjust the clearance as follows:

Note: For measurement, refer to 14-19 "Inspection and Adjustment".

- (1) If clearance is too large, increase shim thickness (a) as required.
- (2) Increase the same thickness of shims (b) as shims (a).
- (3) Shims (a) are available in two thicknesses: 0.5 and 1 mm (0.020 and 0.04 in.) and shim (b) is available in only 1 mm (0.04 in.) thickness.
- (4) If a 0.5 mm (0.020 in.) thick shim (a) is added, adjustment of shim thickness (b) is unnecessary.

Note: Shim thickness (a) and (b) are adjusted at the factory before shipping to the value in the table below.

Item	Specified value	
	1 ton class	2,3 ton classes
Shim (a)	2 mm (0.08 in.)	1.5 mm (0.059 in.)
Shim (b)	2 mm (0.08 in.)	

Adjusting clearance between lower roller side face and inner mast

Measure the clearance between the lower roller side face and inner mast. If the measured clearance does not meet the standard value, adjust the clearance as follows:

Note: For measurement, refer to 14-19 "Inspection and Adjustment".

If the clearance is too large, increase shim thickness (c) as required.

Note: At the factory, shim thickness (c) is usually adjusted to 1.5mm (0.059 in.) for shipping.

Installing Rollers

To install main rollers on shafts, use a driving tool, and be careful not to strike the outer roller surface. The side of the roller with larger chamfering must face toward the outside. Make sure the rollers rotate smoothly when installed.

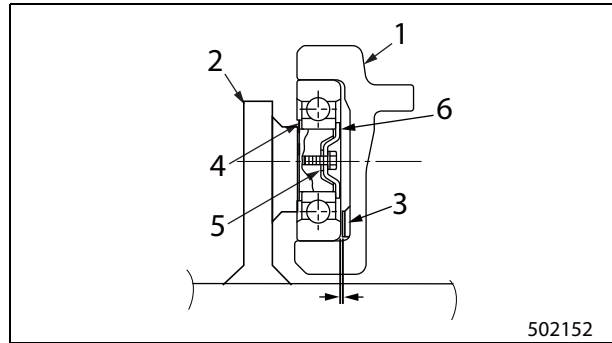

Lift bracket middle roller

- | | |
|-----------------|-------------------|
| 1. Inner mast | 4. Shim (a) |
| 2. Lift bracket | 5. Shim (b) |
| 3. Thrust plate | 6. Roller stopper |

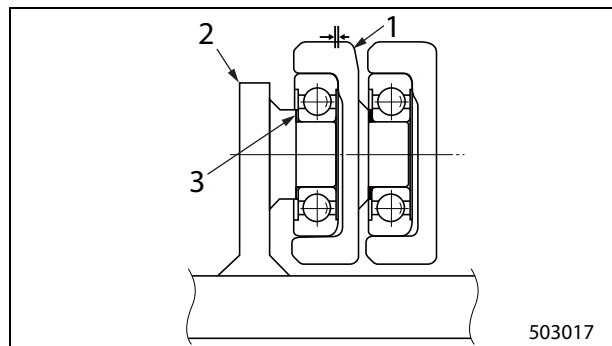

Lift bracket lower roller

- | | |
|-----------------|-------------|
| 1. Inner mast | 3. Shim (c) |
| 2. Lift bracket | |

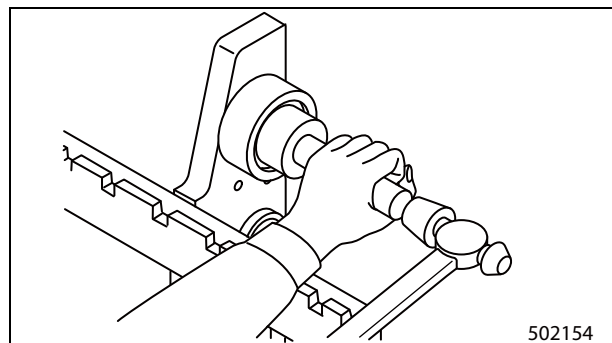

- (6) Lower the lift bracket slightly from the top so that the side roller comes in contact with the inner mast. Measure the clearance between side roller and inner mast. Adjust shim thickness as required. For adjustment, refer to 14-12 "Adjusting clearance between side roller rolling face and inner mast".

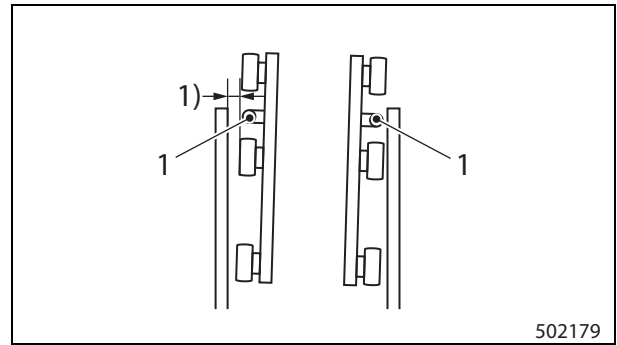

1. Side roller

1) Clearance between side roller rolling face and inner mast

Ref.	Item	Standard
1)	Clearance between side roller rolling face and inner mast	0.1 to 0.5 mm (0.004 to 0.020 in.)

- (7) Raise the lift bracket to the top of the inner mast, and measure the clearance between the lower roller and inner mast. Adjust shim thickness as required. For adjustment, refer to 14-11 "Adjusting clearance between lower roller side face and inner mast".

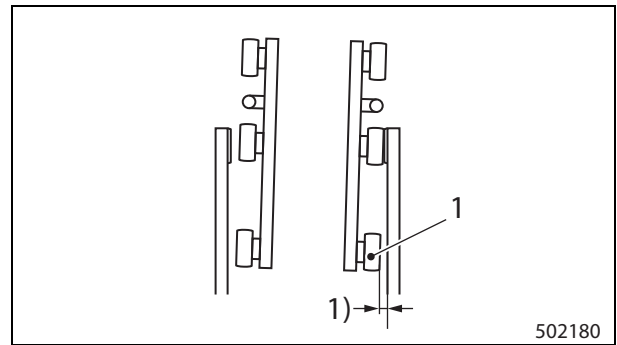

1. Lower roller

1) Clearance between lower roller side face and inner mast thrust face

Ref.	Item	Standard
1)	Clearance between lower roller side face and inner mast thrust face	0.1 to 0.5 mm (0.004 to 0.020 in.)

2.5 Suggestions for Installing Mast and Lift Bracket Assembly

For installation, follow the removal sequence in reverse and observe the instructions below.

Mast support

- (1) Apply a thick coat of grease on the inner surface of the caps and the mast support bushings.
- (2) For 1 ton class:
When installing caps, orient the wider chamfered side 3 toward the center of the chassis. (For fusion cutting processed products)

Note: For casting products, there is no difference between inner and outer sides, however, install them in the same orientation as they were.

- (3) For 2, 3 ton classes:
Chamfering is the same both on the right and left sides. Install the mast supports in the same direction as they were removed.
- (4) For easier greasing, place wood blocks under the mast so that the mast is off the ground.

Adjusting chain tension

Refer to 14-51 "Inspection and Adjustment".

Bleeding lift cylinders

The duplex mast, unlike the other masts, has air bleeding screws at the top of the second lift cylinders.

After installing the mast, start the engine, raise and lower the lift bracket with several strokes and loosen the screws to bleed.

After the proper operation of the lift truck is confirmed, check the oil level in the hydraulic tank.

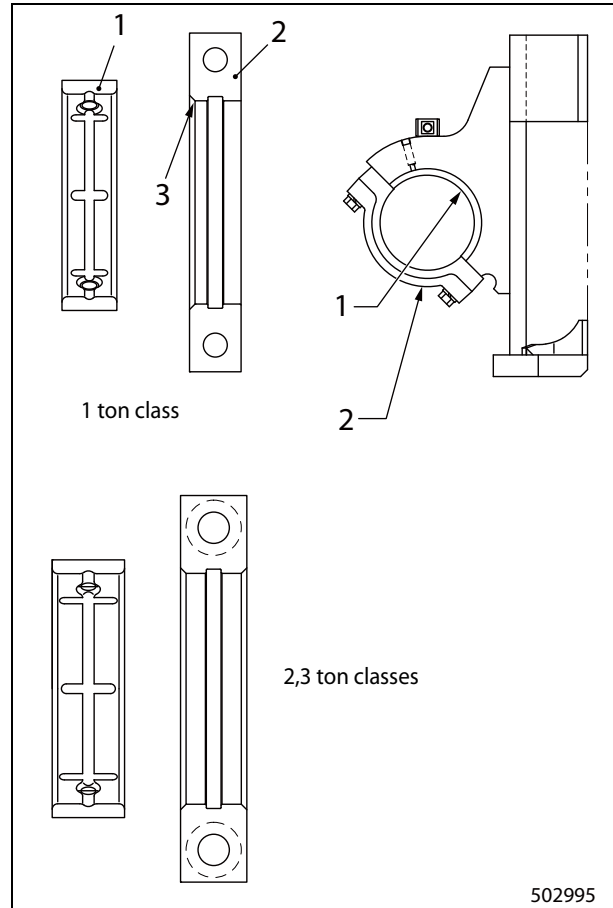

1. Bushing
2. Cap

3. Chamfer

2.18 Mast Rollers and Strips, Removal and Installation Without Removing Mast from Truck

Preparation

- (1) Disconnect the lift bracket assembly from the mast.

Removing first lift cylinders

- (1) Hitch a sling to the first lift cylinder, and suspend it with a hoist. Tie the sling securely to the first lift cylinder to prevent the cylinder from slipping.
- (2) Remove the cylinder mounting bolts. Using the hoist, slowly lift and remove the first lift cylinder.

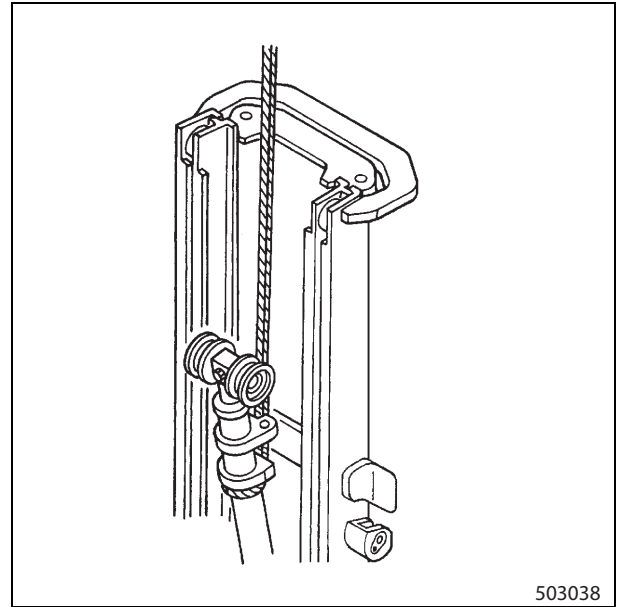

Placing inner mast lower than outer mast

- (1) Lift the front side of the lift truck by 15 to 20 cm (0.6 to 0.8 in.) and place wood blocks underneath.
- (2) Remove the set bolts located on the top of the second lift cylinders. Place a sling around the inner mast. Lift the inner mast using a hoist connected to the sling in order to disengage the second lift cylinders' piston rods from the inner mast. Remove the hose guard.
- (3) Remove clamp bolt of second lift cylinder to separate the second lift cylinder from outer mast. Pull out the second lift cylinders from the mounting seats at the bottom of the outer mast. Tilt the cylinder tops inward until they rest on the outer mast cross member. Using a rope, fix the cylinders onto the cross member.
- (4) Using the hoist, slowly lower the inner mast until the inner mast contacts the second lift cylinders.
- (5) The main rollers of the inner and outer masts can now be removed. Before attempting to remove the main rollers, remove the mast strips and shims first as they tend to drop easily.
- (6) Adjust shim thickness for main rollers and mast strips as required.

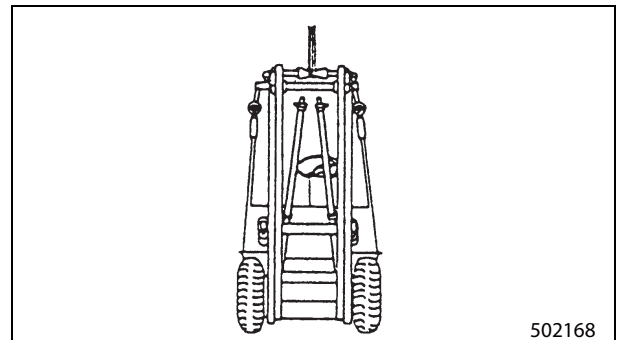

Note: For assembly, follow the disassembly sequence in reverse.

Model	Type	Blade size	Limit	
1 to 2tC	1	HX**** x 500	35 x 100 x 770 to 1970	32.5 mm (1.280 in.)
	2	T****	35 x 100 x 770 to 1520	31.5 mm (1.240 in.)
	3	Without Mark **** or U**** or UQ****	37 x 100 x 1370 to 1970	32.5 mm (1.280 in.)
2 to 2.5t	1	HX**** x 500	40 x 122 x 920 to 1970	35.5 mm (1.398 in.)
	2	T****	40 x 122 x 920 to 1370	35.0 mm (1.378 in.)
			45 x 122 x 1520 to 1970	40.0 mm (1.575 in.)
	3	Without Mark **** or U**** or UQ****	42 x 110 x 920 to 1070	40.0 mm (1.575 in.)
			42 x 125 x 1150 to 1970	40.0 mm (1.575 in.)
3 to 3.5t	1	HX**** x 500	50 x 125 x 1070 to 1970	45.0 mm (1.772 in.)
			50 x 122 x 1070 to 1970	45.0 mm (1.772 in.)
	2	T****	50 x 122 x 1070 to 1520	45.0 mm (1.772 in.)
	3	Without Mark **** or U**** or UQ****	50 x 125 x 1070 to 1970	45.0 mm (1.772 in.)
				45.0 mm (1.772 in.)

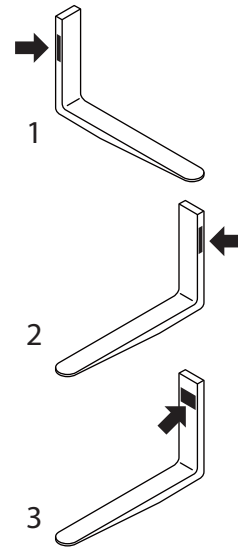

503039

Adjusting clearance between side roller rolling face and inner mast

Measure the clearance between side roller rolling face and inner mast. If the measured clearance does not meet the standard value, adjust the clearance as follows:

Note: For measurement, refer to 14-84 "Inspection and Adjustment".

If the clearance is too large, increase shims thickness (d) as required.

Note: At the factory, shim thickness (d) is usually adjusted to 1.5 mm (0.059 in.) for shipping.

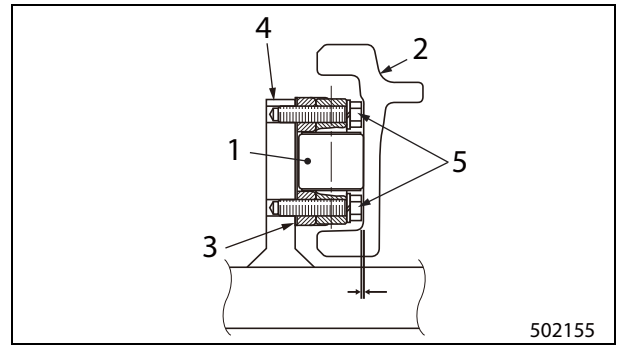

- 1. Side roller
- 2. Inner mast
- 3. Shim (d)
- 4. Lift bracket
- 5. Roller mounting bolt

3.12 Installing Mast Rollers (All Mast Models)

Mast rollers are identical in shape and size with lift bracket lower rollers.

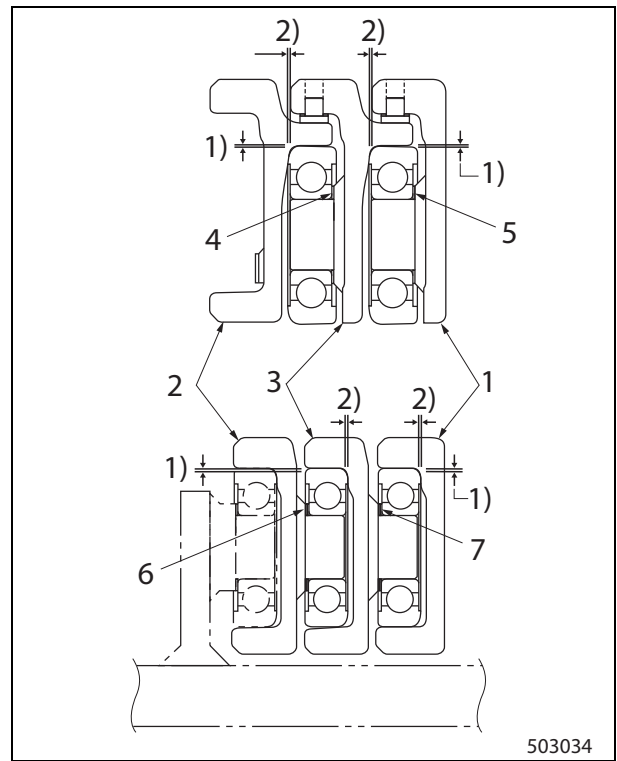

- 1. Outer mast
- 2. Inner mast
- 3. Middle mast
- 4. Shim (g)
- 5. Shim (h)
- 6. Shim (i)
- 7. Shim (j)
- 1) Clearance between main roller rolling face and mast
- 2) Clearance between main roller side face and mast

Ref.	Item	Standard
1)	Clearance between main roller rolling face and mast	1 mm (0.04 in.) or less
2)	Clearance between main roller side face and mast	0.1 to 0.5 mm (0.004 to 0.020 in.)

- (6) Lower the lift bracket slightly from the top so that the side roller comes in contact with the inner mast. Measure the clearance between side roller and inner mast. Adjust shim thickness as required. For adjustment, refer to 14-76 "Adjusting clearance between side roller rolling face and inner mast".

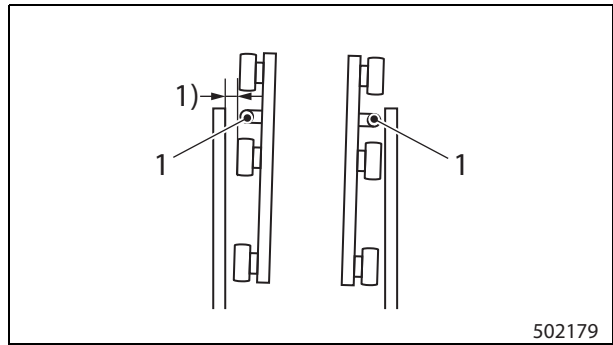

1. Side roller
1) Clearance between side roller rolling face and inner mast

Ref.	Item	Standard
1)	Clearance between side roller rolling face and inner mast	0.1 to 0.5 mm (0.004 to 0.020 in.)

- (7) Raise the lift bracket to the top of the inner mast, and measure the clearance between the lower roller and inner mast. Adjust shim thickness as required. For adjustment, refer to 14-75 "Adjusting clearance between lower roller side face and inner mast".

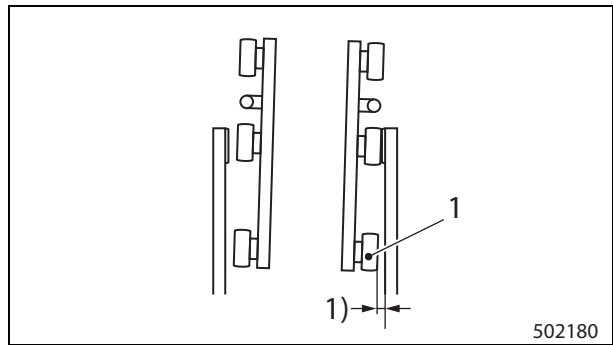

1. Lower roller
1) Clearance between lower roller side face and inner mast thrust face

Ref.	Item	Standard
1)	Clearance between lower roller side face and inner mast thrust face	0.1 to 0.5 mm (0.004 to 0.020 in.)

3.24 Adjusting Mast Roller Clearance (All Mast Models)

Measuring back-to-front clearance on mast main rollers

- (1) Tilt the mast fully backward.
- (2) Using a thickness gauge, measure the clearance between inner mast lower roller and outer mast's rolling contact face.
- (3) If the clearance deviates from the specified value, replace with oversize roller. For replacement, refer to 14-76 "Installing Mast Rollers (All Mast Models)".

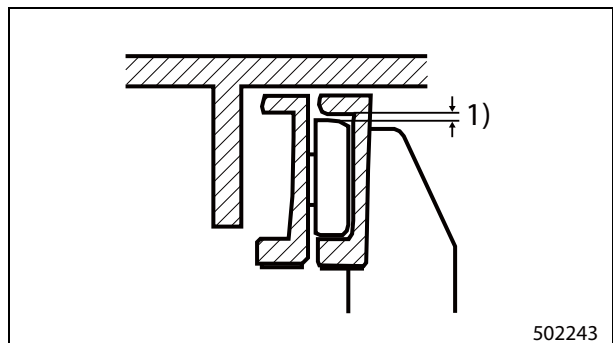



1) Clearance between main roller rolling face and mast

Ref.	Item	Standard
1)	Clearance between main roller rolling face and mast	1.0 mm (0.039 in.) or less

2. Tightening Torques for Standard Bolts and Nuts

- (1) The tables below show the tightening torque for general bolts and nuts. For the tightening torque of the bolts and nuts for specific use, refer to the torque specified in each section.
- (2) The table shows the standard value. Bolts and nuts should be tightened within $\pm 10\%$ range of the torque value in the table. When you use an impact wrench, tighten bolts and nuts within $\pm 20\%$ range if the value is 137 N·m (14.0 kgf·m) [101.05 lbf·ft] or less, and tighten $\pm 15\%$ if the value is more than 137 N·m (14.0 kgf·m) [101.05 lbf·ft].
- (3) Threads and seating faces are in a dry condition.

2.1 Metric Fine Thread

With spring washer										
Nominal size	Pitch	 500244			 500245			 500246		
		N·m	kgf·m	lbf·ft	N·m	kgf·m	lbf·ft	N·m	kgf·m	lbf·ft
6 (0.24)	1 (0.04)	7.4	0.75	5.46	9.6	0.98	7.08	12.7	1.30	9.37
8 (0.31)	1.25 (0.05)	16.7	1.70	12.32	22.6	2.30	16.67	30.4	3.10	22.42
10 (0.39)	1.25 (0.05)	34.3	3.50	25.30	45.1	4.60	33.26	69.6	7.10	51.33
12 (0.47)	1.25 (0.05)	63.7	6.50	46.98	82.4	8.40	60.77	122.6	12.50	90.42
14 (0.55)	1.5 (0.06)	102.0	10.40	75.23	132.4	13.50	97.65	192.2	19.60	141.76
16 (0.63)	1.5 (0.06)	157.9	16.10	116.46	202.0	20.60	148.99	287.3	29.30	211.90
18 (0.71)	1.5 (0.06)	224.6	22.90	165.65	292.2	29.80	215.51	413.8	42.20	305.20
20 (0.79)	1.5 (0.06)	310.9	31.70	229.30	404.0	41.20	297.97	573.8	58.51	423.21
22 (0.87)	1.5 (0.06)	413.8	42.20	305.20	537.5	54.81	396.43	763.0	77.80	562.75
24 (0.94)	1.5 (0.06)	547.2	55.80	403.59	711.0	72.50	524.40	1006.2	102.60	742.12
27 (1.06)	1.5 (0.06)	794.3	80.99	585.84	1032.6	105.29	761.59	1451.1	147.97	1072.47
30 (1.18)	1.5 (0.06)	1100.3	112.20	811.53	1430.8	145.90	1055.29	2012.3	205.19	1484.17
33 (1.30)	1.5 (0.06)	1467.1	149.60	1082.06	1907.4	194.50	1406.80	2680.2	273.30	1976.78
36 (1.42)	1.5 (0.06)	1918.2	195.70	1414.77	2493.8	254.29	1839.30	3497.1	356.60	2579.29
39 (1.54)	1.5 (0.06)	2461.5	251.00	1815.48	3198.8	326.18	2359.28	4469.9	455.80	3296.77

Item		Specified value				
		2Z ton class	3ton class		3.5ton class	
		Gasoline		Diesel	Gasoline	Diesel
Lift chain elongation limit (20 links)		392 mm (15.43 in.)	523 mm (20.59 in.)			
Fuel tank capacity		66 L (17.44 US gal.)				
Coolant quantity (reserve tank 0.65 liter [0.17 cu.in.] included)		6.8 L (1.797 US gal.)	8.7 L (2.299 US gal.)	6.8 L (1.797 US gal.)	8.7 L (2.299 US gal.)	
Engine oil	Engine	3.5 L (0.925 US gal.)	9.0 L (2.378 US gal.)	3.5 L (0.925 US gal.)	9.0 L (2.378 US gal.)	
	Oil filter	0.3 L (0.079 US gal.)	1.0 L (0.264 US gal.)	0.3 L (0.079 US gal.)	1.0 L (0.264 US gal.)	
	Total	3.8 L (1.004 US gal.)	10.0 L (2.642 US gal.)	3.8 L (1.004 US gal.)	10.0 L (2.642 US gal.)	
Transmission oil	Manual Truck	5 L (1.32 US gal.)				
	Powershift Truck	10 L (2.64 US gal.)				
Transfer and differential gear oil level		9.3 L (2.457 US gal.)	8.7 L (2.299 US gal.)			
Hydraulic oil		39 L (10.30 US gal.)				
Brake oil capacity		135 cc (8.24 cu. in.)				
Battery electrolyte specific gravity, corrected to 20°C (68°F)		1.26 to 1.28				

Safety Cautions

⚠ WARNING

Fire and explosion

Keep flames away

Store fuel and engine oil in a well ventilated designated area.

Make sure the fuel and engine oil container caps are tightly closed.

Do not use flames, do not smoke, and do not work near a heater or other fire hazard where fuel or oil is handled or when cleaning solvent is being used for washing parts.

Wipe off spilled fuel, oil and LLC immediately and thoroughly. Spilled fuel, oil and LLC may ignite and cause a fire.



Keep surrounding area tidy and clean

Do not leave combustible or explosive materials, such as fuel, engine oil and LLC, near the engine. Such substances can cause fire or explosion.

Remove dust, dirt and other foreign materials accumulated on the engine and surrounding parts thoroughly. Such materials can cause fire or the engine to over-heat. In particular, clean the top surface of the battery thoroughly. Dust can cause a short-circuit.

Always operate the engine at a position at least 1 m [3.28 ft.] away from buildings and other equipment to prevent possible fire caused by engine heat.

Care about fuel, oil and exhaust gas leakage

If any fuel, oil or exhaust gas leakage is found, immediately take corrective measures to stop it.

Such leakages, if left uncorrected, can cause fuel or engine oil to reach hot engine surfaces or hot exhaust gas to contact flammable materials, possibly leading to personal injury and/or damage to equipment.

Use explosion-proof lighting apparatus

When inspecting fuel, engine oil, coolant, battery electrolyte, etc., use a flameproof light. An ordinary light, if accidentally broken, may ignite and cause an explosion.

Prevent electrical wires from short-circuiting

Avoid inspecting or servicing the electrical system with the ground cable connected to the battery. Otherwise, a fire could result from short-circuiting. Be sure to disconnect the battery cable from the negative (-) terminal before beginning with the work procedure.

Short-circuits, possibly resulting in fire, may be caused by a loose terminal or damaged cable/wire. Inspect the terminals, cables and wires, and repair or replace the faulty parts before beginning with the service procedure.

Keep fire extinguishers and first-aid kit handy

Keep fire extinguishers handy, and become familiar with their usage.

Keep a first-aid kit at the designated place where it is easily accessible by anyone at any time.

Establish response procedures to follow in the event of fire or accident. Provide an emergency evacuation route, contact points, and means of communication in case of emergency.



3. Engine serial number location

The engine serial number is stamped on the right side of crankcase.

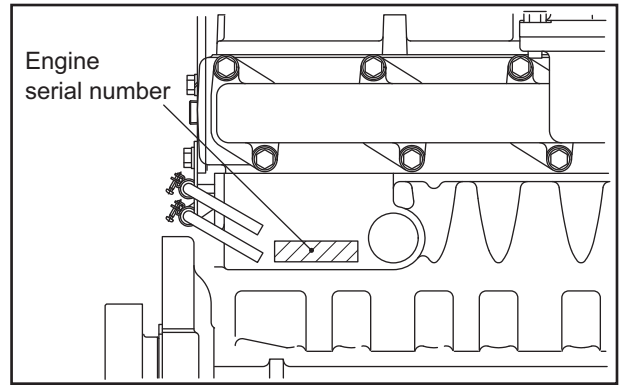

Stamp location of engine serial number

2.1.3 Lubrication system

Table 2-10 Tightening torque table - Lubrication system

Description	Threads Dia × Pitch (mm)	Torque			Remark
		N·m	kgf·m	lbf·ft	
Oil pan	8 × 1.25	11.5 ± 1.5	1.2 ± 0.1	8.5 ± 1.1	
Oil pan drain plug	14 × 1.5	39 ± 5	4 ± 0.5	28.8 ± 3.6	
Oil pump gear	10 × 1.25	33 ± 5	3.4 ± 0.5	24.3 ± 3.6	
Oil pressure relief valve	22 × 1.5	49 ± 4.9	5 ± 0.5	36.2 ± 3.6	
Relief valve plug	18 × 1.5	44 ± 4.9	4.5 ± 0.5	32.5 ± 3.6	

2.1.4 Cooling system

Table 2-11 Tightening torque table - Cooling system

Description	Threads Dia × Pitch (mm)	Torque			Remark
		N·m	kgf·m	lbf·ft	
Thermostat case	8 × 1.25	18.5 ± 1.5	1.9 ± 0.1	13.6 ± 1.1	
Water drain plug	1/4-18NPTF	39.2 ± 3.9	4 ± 0.3	28.9 ± 2.8	
Water pump and water pump cover fixing bolt	8 × 1.25	9.8 ± 1	1 ± 0.1	7.2 ± 0.7	
Water pump and crankcase fixing bolt	8 × 1.25	18.2 ± 3.4	1.9 ± 0.3	13.4 ± 2.5	
Water pump plug	R3/8	31.9 ± 2.4	3.3 ± 0.2	23.5 ± 1.8	

2.1.5 Inlet and exhaust systems

Table 2-12 Tightening torque table - Inlet and exhaust systems

Description	Threads Dia × Pitch (mm)	Torque			Remark
		N·m	kgf·m	lbf·ft	
Exhaust manifold	8 × 1.25	18.5 ± 3.5	1.9 ± 0.3	13.6 ± 2.5	

2.1.6 Electrical system

Table 2-13 Tightening torque table - Electrical system

Description	Threads Dia × Pitch (mm)	Torque			Remark
		N·m	kgf·m	lbf·ft	
Starter terminal B	8 × 1.25	9.8 ⁺² ₀	1 ^{+0.2} ₀	7.2 ^{+1.4} ₀	
Alternator pulley	17 × 1.5	117.5 ± 19.5	12 ± 1.9	86.7 ± 14.3	
Glow plug (Engine body)	10 × 1.25	17.5 ± 2.5	1.8 ± 0.2	12.9 ± 1.8	
Glow plug (terminal)	4 × 0.7	1.3 ± 0.2	0.13 ± 0.02	0.9 ± 0.1	
Magnetic valve assembly	24 × 1	20 ± 5	2 ± 0.5	15 ± 3.6	

1.4 Removing cylinder head assembly

CAUTION

When removing the cylinder head gasket, be careful not to damage the cylinder head or crankcase surface with tools such as a screwdriver.

- (1) Remove the cylinder head bolt.
- (2) Remove the cylinder head assembly by lifting it up.
 Note: If the cylinder head assembly cannot be removed due to crimping of the cylinder head gasket, tap the thick area on the side of the cylinder head using a plastic hammer to give it a shock.
 Do not lift up the cylinder head by one person.
 Use crane or lift up by two persons.
- (3) Remove the gasket from the cylinder head.
 Note: If there is a cylinder head problem, check the bolts for tightness with a torque wrench before removing the cylinder head bolts.

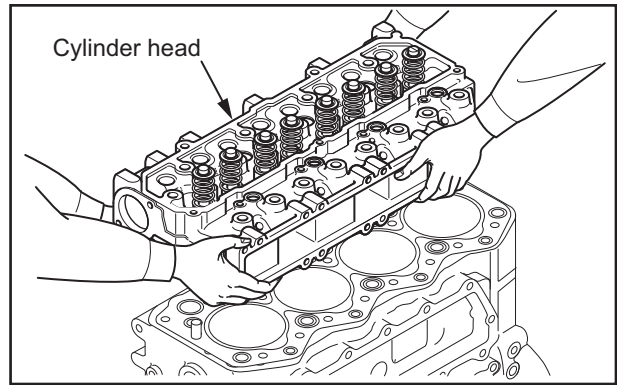

Removing cylinder head assembly

1.5 Removing valve and valve spring

Using a valve spring pusher, compress the valve spring evenly and remove the valve cotters.

Note: If valves are reusable, mark each valve seat and the mating valve for identifying their original positions.
 Do not mix valve seats with other valve.

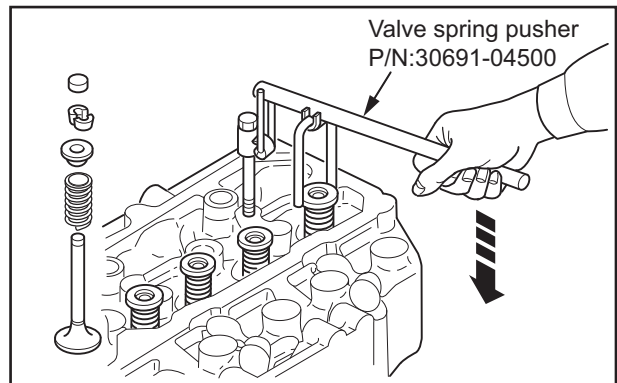

Removing valve and valve spring

1.6 Removing valve stem seal

Grab the valve stem seal with pliers and remove.

Note: Be sure to replace the valve stem seal with a new one when reassembling the valve and valve spring.

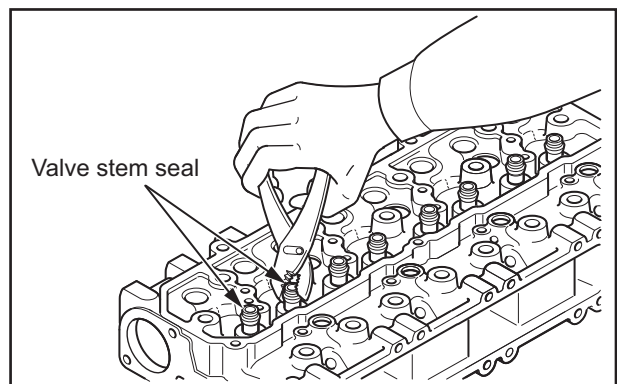

Removing valve stem seal

INSPECTION AND REPAIR OF BASIC ENGINE

1. Inspecting and repairing cylinder head and valve mechanism6-2
 - 1.1 Measuring clearance between rocker bushing and rocker shaft..... 6-2
 - 1.2 Measuring valve stem outside diameter and valve guide inside diameter 6-2
 - 1.3 Replacing valve guide..... 6-3
 - 1.4 Inspecting valve face 6-4
 - 1.5 Refacing valve face..... 6-4
 - 1.6 Refacing valve seat..... 6-5
 - 1.7 Replacing valve seat..... 6-5
 - 1.8 Lapping valve and valve seat..... 6-6
 - 1.9 Measuring perpendicularity and free length of valve spring..... 6-6
 - 1.10 Measuring distortion of the bottom surface of the cylinder head..... 6-7
 - 1.11 Measuring push rod runout..... 6-7
 - 1.12 Removing combustion jet..... 6-8
2. Inspecting and repairing flywheel6-9
 - 2.1 Measuring flatness of flywheel..... 6-9
 - 2.2 Measuring flywheel face and radial runouts 6-9
 - 2.3 Inspecting ring gear 6-9
 - 2.4 Replacing ring gear..... 6-9
 - 2.4.1 Removing ring gear.....6-9
 - 2.4.2 Installing ring gear.....6-9
3. Inspecting and repairing timing gear and camshaft.....6-10
 - 3.1 Measuring timing gear backlash 6-10
 - 3.2 Measuring idler gear and camshaft gear end play 6-10
 - 3.3 Measuring cam lift..... 6-10
 - 3.4 Measuring camshaft runout 6-11
 - 3.5 Measuring camshaft journal outside diameter 6-11
 - 3.6 Measuring idler bushing inside diameter and idler shaft outside diameter 6-11
 - 3.7 Replacing idler shaft 6-11
 - 3.8 Measuring clearance between tappet and tappet guide hole 6-12
 - 3.9 Inspecting tappet..... 6-12
 - 3.9.1 Contact surface of camshaft6-12
 - 3.9.2 Contact surface of push rod6-12
 - 3.10 Inspecting V-belt groove wear 6-12
4. Inspecting and repairing piston, connecting rod, crankshaft and crankcase 6-13
 - 4.1 Measuring crankcase top surface distortion..... 6-13
 - 4.2 Measuring cylinder inside diameter..... 6-14
 - 4.3 Measuring piston outside diameter 6-15
 - 4.4 Measuring piston ring end gap..... 6-15
 - 4.5 Measuring clearance between piston ring groove and piston ring..... 6-16
 - 4.6 Measuring piston pin bore diameter and piston pin outside diameter 6-16
 - 4.7 Measuring piston protrusion..... 6-17
 - 4.8 Measuring clearance between connecting rod bearing and crankpin 6-18
 - 4.9 Measuring clearance between connecting rod bushing and piston pin... 6-18
 - 4.10 Replacing connecting rod bushing 6-19
 - 4.11 Inspecting connecting rod bend and twist..... 6-19
 - 4.12 Inspecting connecting rod bearing 6-20
 - 4.13 Measuring connecting rod end play 6-20
 - 4.14 Weight difference of connecting rod assembly in one engine 6-20
 - 4.15 Measuring crankshaft journal outside diameter..... 6-21
 - 4.16 Measuring crankshaft crankpin outside diameter..... 6-21
 - 4.17 Grinding crankshaft..... 6-22
 - 4.18 Measuring crankshaft end play 6-23
 - 4.19 Measuring crankshaft runout..... 6-23
 - 4.20 Replacing crankshaft gear 6-24
 - 4.20.1 Removing crankshaft gear..... 6-24
 - 4.20.2 Installing crankshaft gear..... 6-24
 - 4.21 Installing oil seal sleeve 6-25
 - 4.22 Removing oil seal sleeve 6-26
 - 4.23 Inspecting main bearing surface 6-26
 - 4.24 Measuring clearance between main bearing and crankshaft journal 6-27

4.2 Measuring cylinder inside diameter

- (1) Measure the inside diameter of the cylinder at three levels, i.e., upper (with much stepped wear), middle, and lower levels, in both directions parallel to and perpendicular to the crankshaft direction.
- (2) If the measurement is between the repair limit and replacement limit, re-bore the cylinder to +0.25 mm [0.0098 in.] or +0.5 mm [0.0197 in.] oversize. Hone the re-bored cylinder to the accuracy of the standard.
- (3) Use oversized piston and piston rings to fit the rebored cylinder.
- (4) If the cylinder is worn unevenly, select an oversized diameter that ensures complete roundness when the cylinder is re-bored. All cylinders must be re-bored to the same oversized diameter if one cylinder is re-bored.
- (5) If the cylinder has a slight wear and is reused after replacing only the piston rings, remove the steps in worn portion in the upper part of the cylinder using a ridge reamer. Hone it as necessary.

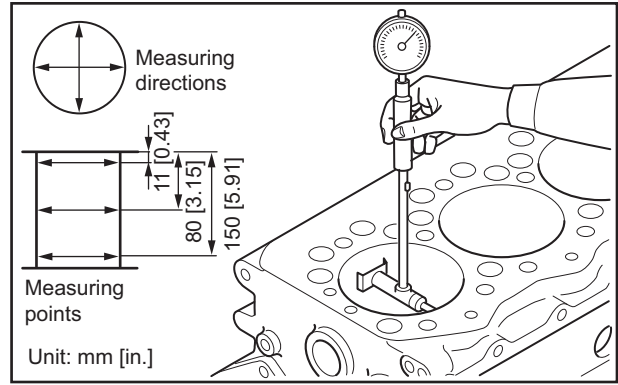

Measuring cylinder inside diameter

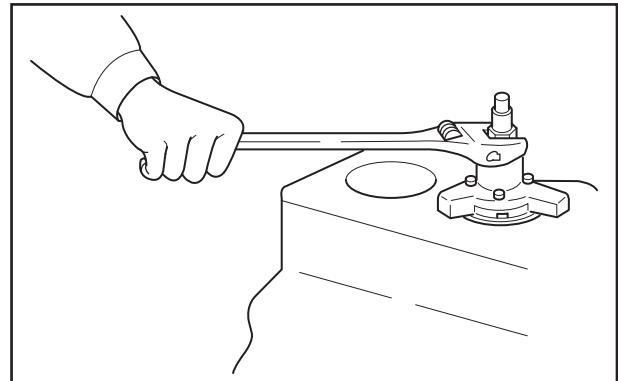

Refacing using a ridge reamer

Item	Standard	Limit
Cylinder inside diameter	94.000 to 94.035 mm [3.7008 to 3.7022 in.]	Repair limit: 94.200 mm [3.7087 in.] Replace limit: 94.700 mm [3.7283 in.]
Circularity	0.01 mm [0.0004 in.] or less	-
Cylindricity	0.015 mm [0.0006 in.] or less	-

4.24 Measuring clearance between main bearing and crankshaft journal

- (1) Reassemble main bearings.
- (2) Tighten the main bearing caps to the specified torque.
- (3) Measure the inside diameter of the main bearings.
- (4) Measure the outside diameter of the crank journal.
- (5) Calculate the clearance between the inside diameter of the main bearing and outside diameter of the crank journal.
- (6) Replace the main bearing if the clearance exceeds the limit.
- (7) Measure the clearance between the main bearing cap and the crank journal again. Use the undersize bearing if the limit is exceeded.
- (8) If an undersize bearing is used, grind the crank journal to the specified undersize.

Item	Standard	Limit
Clearance between main bearing and crankshaft journal	0.050 to 0.110 mm [0.0020 to 0.0043 in.]	0.200 mm [0.0079 in.]

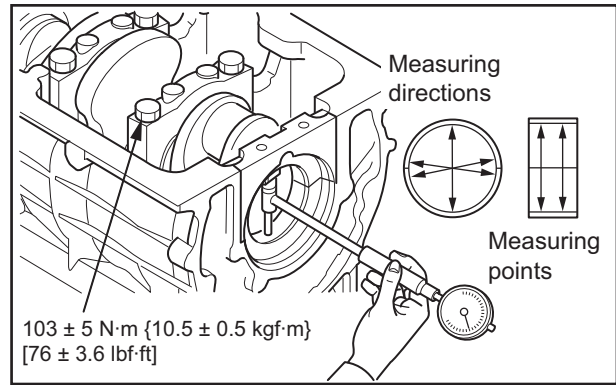

Measuring inside diameter of lower hole of main bearing

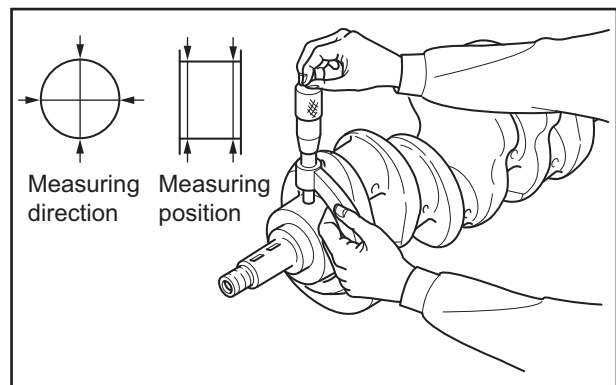

Measuring crank journal outside diameter

2.13 Installing oil pan

- (1) Clean the mount surfaces of the crankcase, timing gear case, and oil pan.
- (2) Squeeze ThreeBond 1207C (32A91-05100: liquid gasket) in a 4 mm [0.16 in.] diameter bead all around the oil pan flange periphery, and spread it.
- (3) Install the oil pan to the crankcase within five minutes after applying liquid gasket.
- (4) Tighten the mounting bolts to the specified torque.

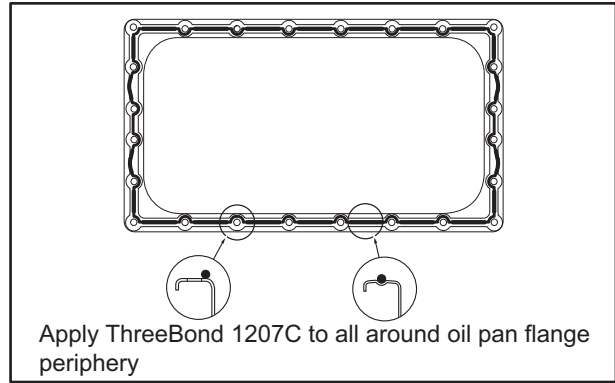

Liquid gasket application position

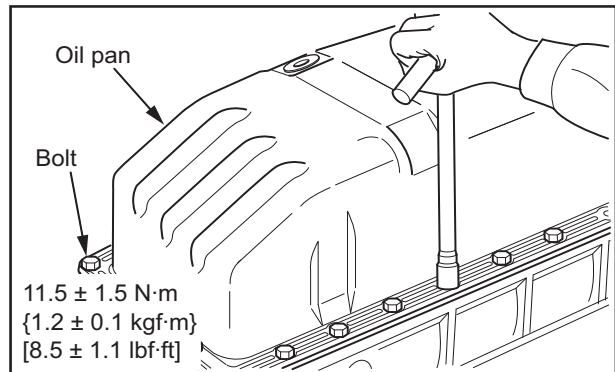

Installing oil pan

2.14 Installing insulator cover and gear case cover

Tighten the insulator cover and gear case cover mounting bolts evenly.

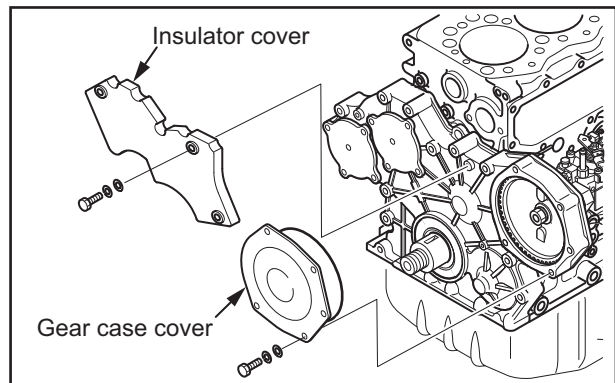

Installing insulator cover and gear case cover

2.15 Installing crankshaft pulley

CAUTION
The bar could come off. Be very careful.

- (1) Screw two guide bolts into the threaded holes at the rear end of the crankshaft. Place a bar across the two guide bolts so that the crankshaft does not turn.
- (2) Install the woodruff key on the crankshaft.
- (3) Install the crankshaft pulley and tighten the nuts to the specified torque.

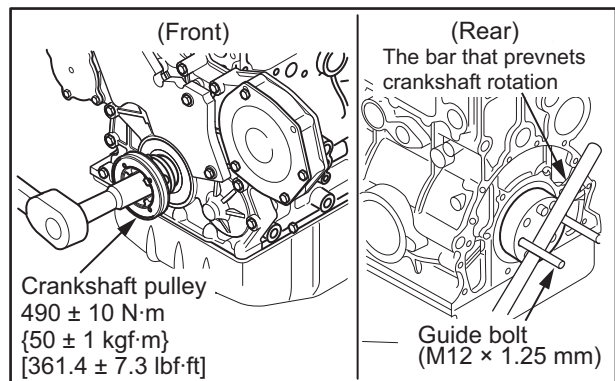

Installing crankshaft pulley

2.3 Disassembling and inspecting fuel injection nozzle

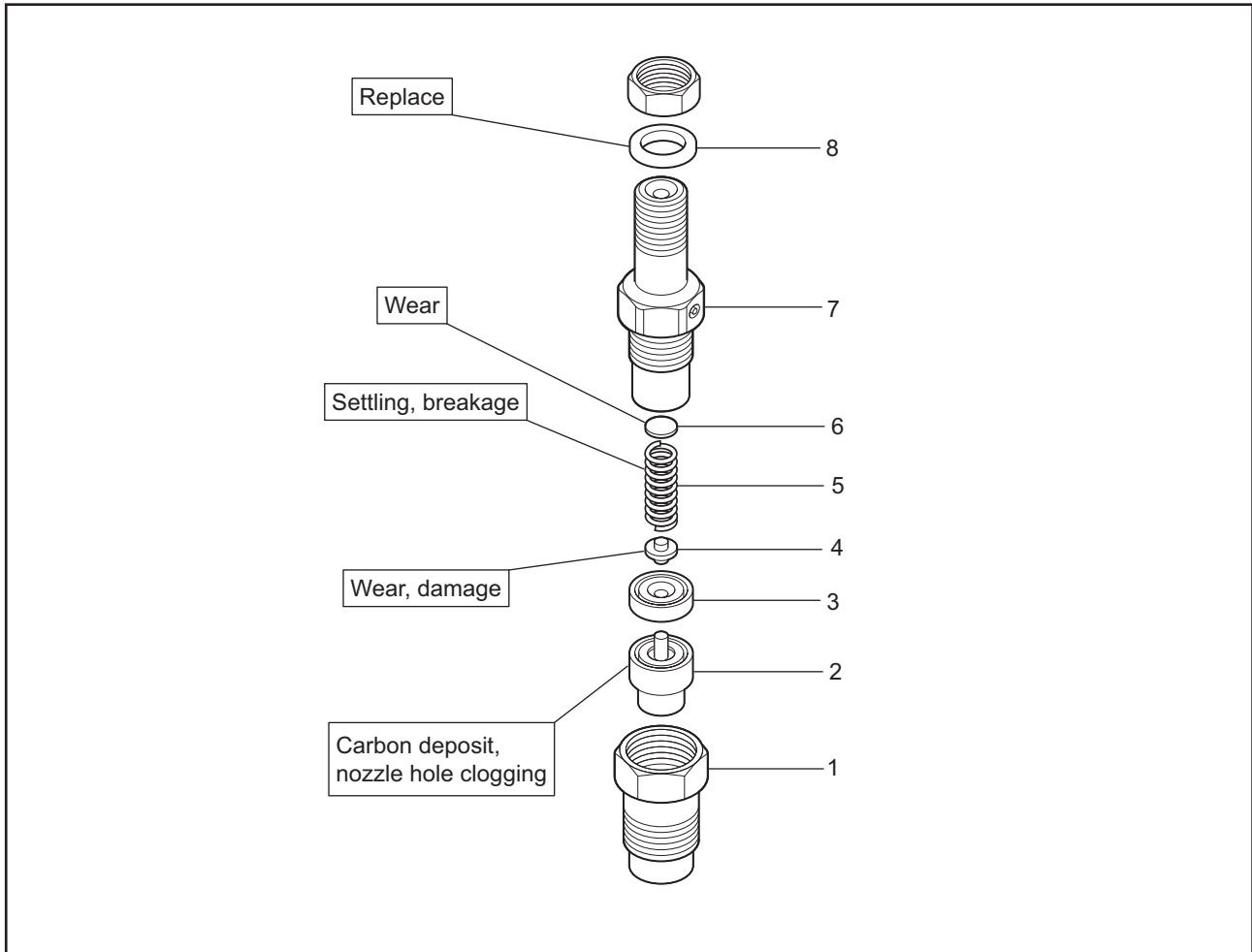

Disassembling and inspecting fuel injection nozzle

Disassembling sequence

- | | | |
|------------------------|-------------------|-----------------|
| 1 Nozzle retaining nut | 4 Pressure pin | 7 Nozzle holder |
| 2 Nozzle tip assembly | 5 Pressure spring | 8 Gasket |
| 3 Distance piece | 6 Washer | |

2.2.4 Measuring clearance between main shaft and pump case

Measure the diameter of the shaft and the inside diameter of the bore in the case in order to find the clearance between the shaft and the bore. If the clearance exceeds the limit, replace the oil pump assembly.

Item	Standard	Limit
Main shaft outside diameter (between case)	15.985 to 16.000 mm [0.6293 to 0.6299 in.]	-
Clearance between main shaft and pump case	0.032 to 0.074 mm [0.0013 to 0.0029 in.]	0.150 mm [0.0059 in.]

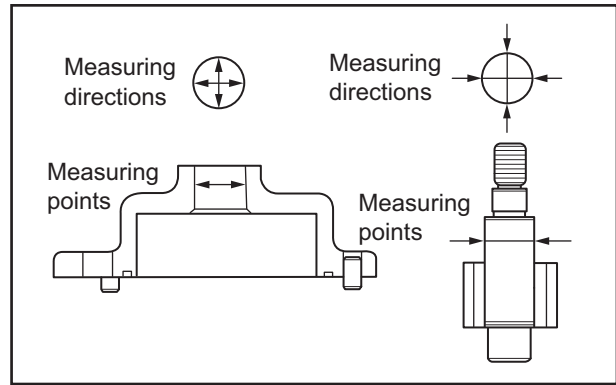

Measuring clearance between main shaft and pump case

2.2.5 Measuring clearance between main shaft and bushing

Measure the diameter of the main shaft and the inside diameter of the oil pump bushing in the crankcase to find the clearance between the two. If the clearance exceeds the limit, replace the bushing or the oil pump assembly.

Item	Standard	Limit
Main shaft outside diameter (between oil pump bushing)	13.957 to 13.975 mm [0.5495 to 0.5502 in.]	-
Clearance between main shaft and oil pump bushing	0.025 to 0.111 mm [0.0010 to 0.0044 in.]	0.200 mm [0.0079 in.]

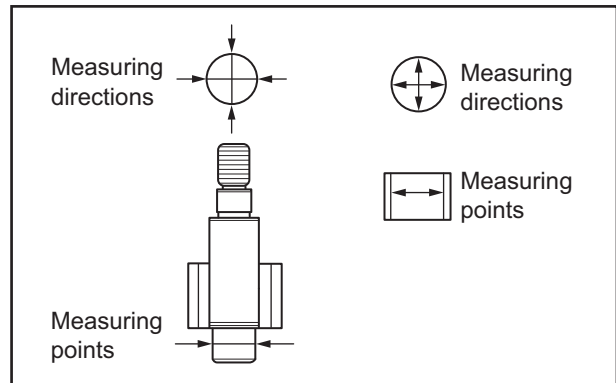

Measuring clearance between main shaft and bushing

2.2.6 Installing oil pump bushing

CAUTION

Install the oil pump bushing in the crankcase so that it is even with the front face of the crankcase.

Install the oil pump bushing by using the oil pump bushing installer.

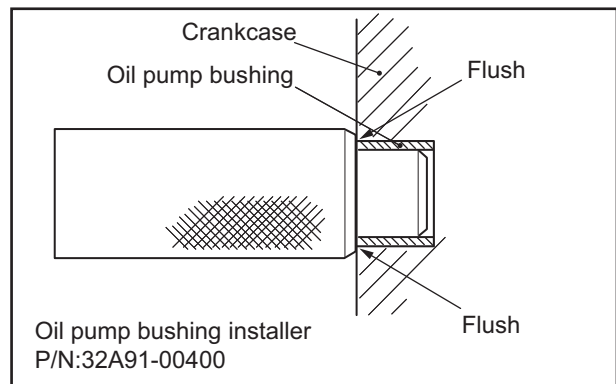

Installing oil pump bushing

3.2 Installing thermostat

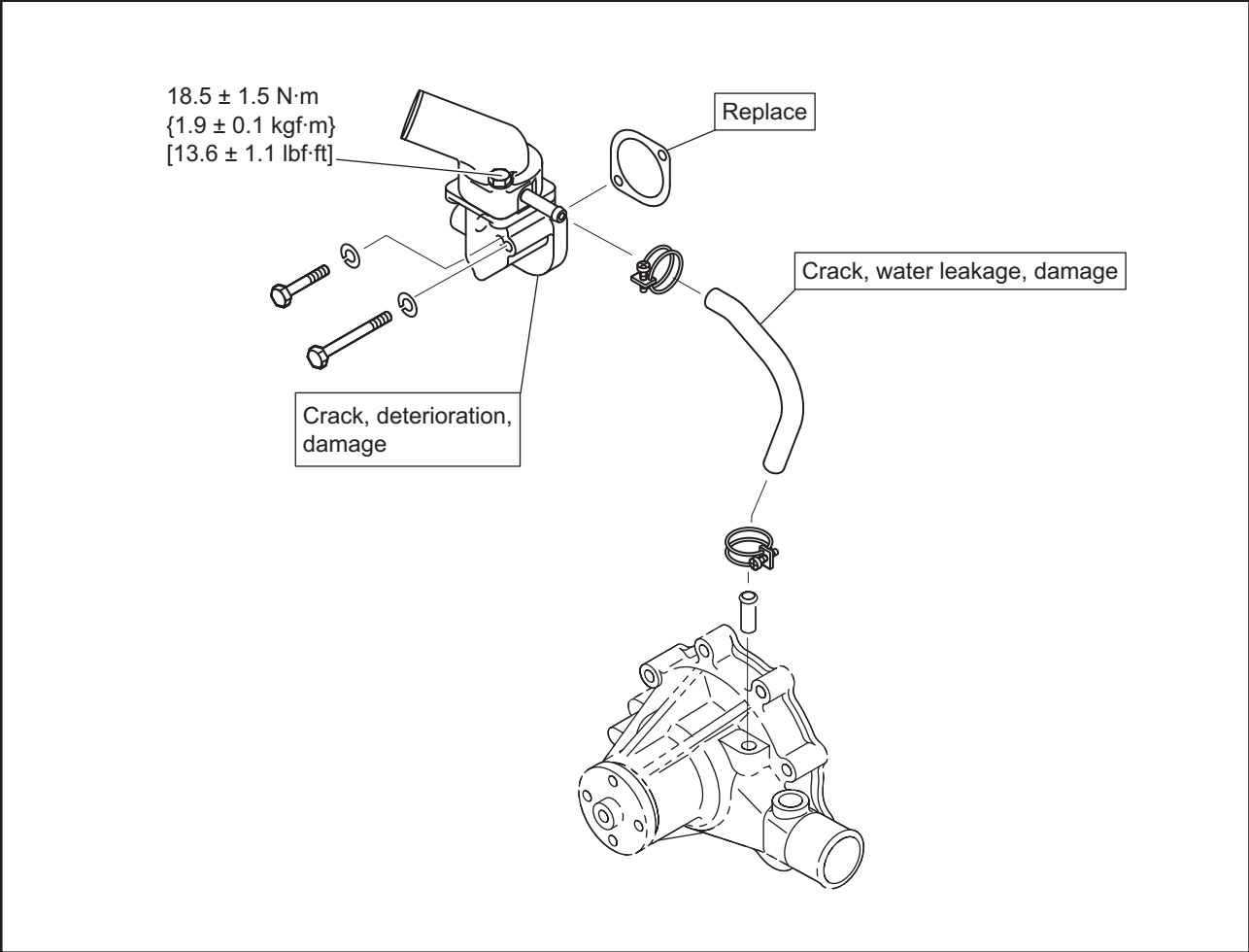

Installing thermostat

1.5 Removing glow plug

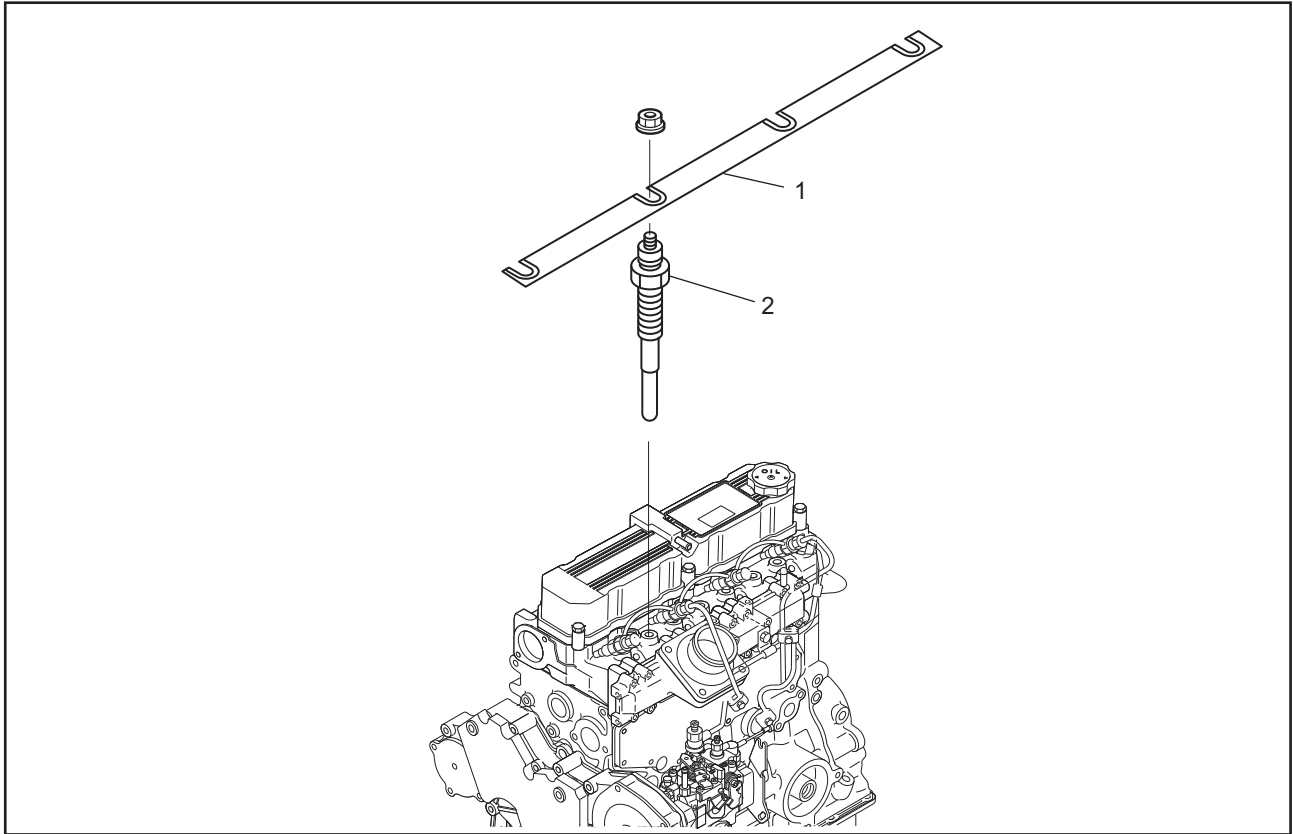

Removing glow plug

Removing sequence

1 Glow plug plate

2 Glow plug

2.5.5 Removing overrunning clutch

Remove the center bracket, gear and overrunning clutch.
Then, remove the spring set and lever.

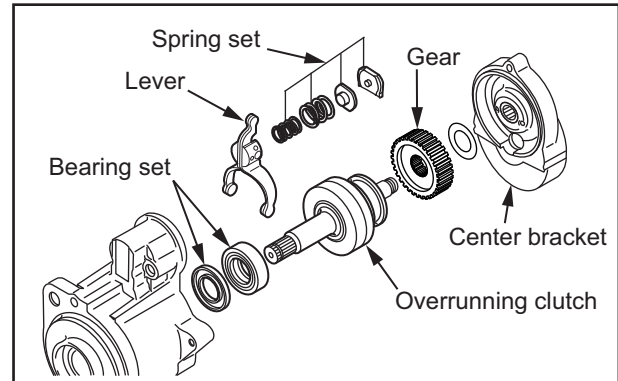

Disassembling starter(3)

2.10.2 Installing stator

CAUTION

Soldering must be finished as quickly as possible.
Extended heating will damage the diodes.

Install the stator and solder the leads of the stator to the rectifier.

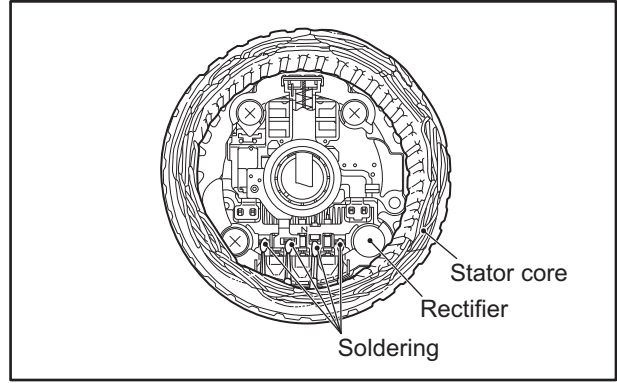

Installing stator

2.10.3 Installing front bearing

Drive the front bearing into the front bracket and secure the bearing retainer with a screw.

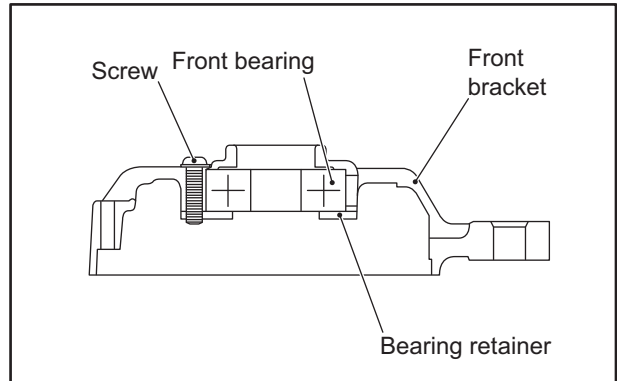

Installing front bearing

2.10.4 Installing rear bearing

Press-fit the rear bearing to the rotor.

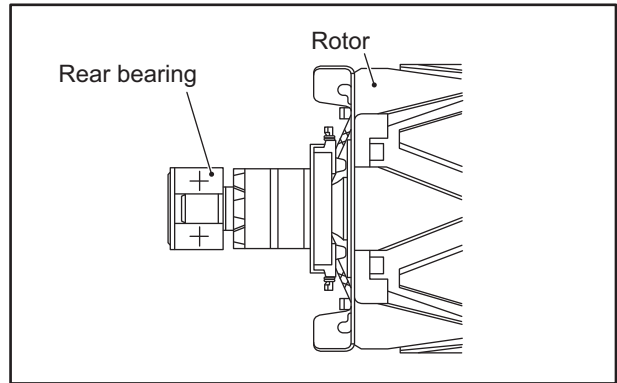

Installing rear bearing

2.10.5 Installing pulley

- (1) Insert the rotor into the front bracket.
Apply a cloth to the rotor and set it in a vise.
- (2) Install the spacer and pulley, and secure the pulley with a nut.

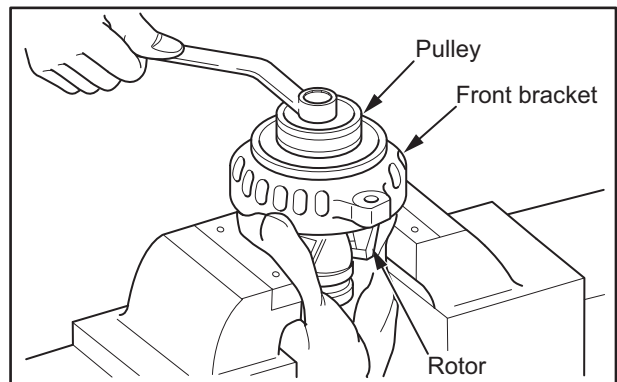

Installing pulley

- (8) Install the flange plate and the fuel injection pump gear to the fuel injection pump.
- (9) Align mark A of the fuel injection pump with mark B on the flange plate as shown in procedure (4) above and tighten the nut.

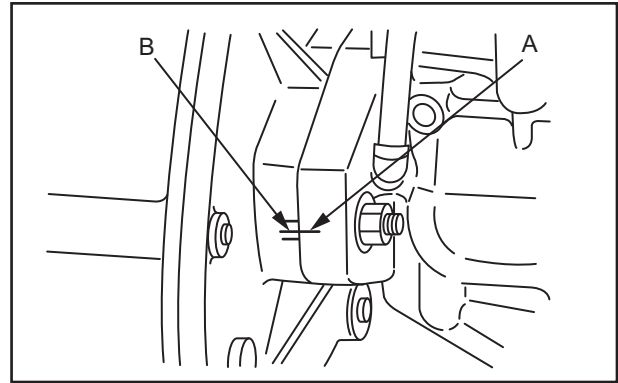

Alignment mark of fuel injection pump gear

- (10) After aligning the timing marks of the fuel injection pump gear and the idler gear, install the fuel injection pump to the front plate.

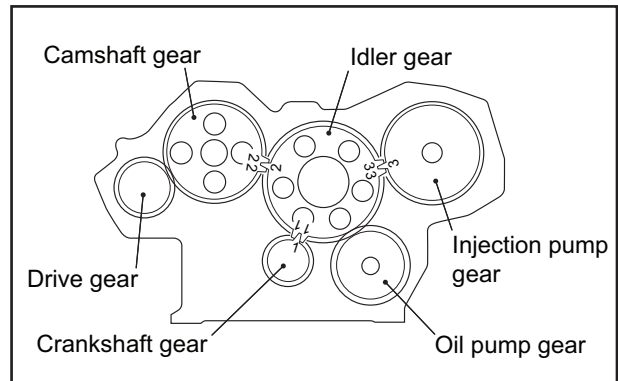

Match mark of gears

- (11) Install the gear case cover.

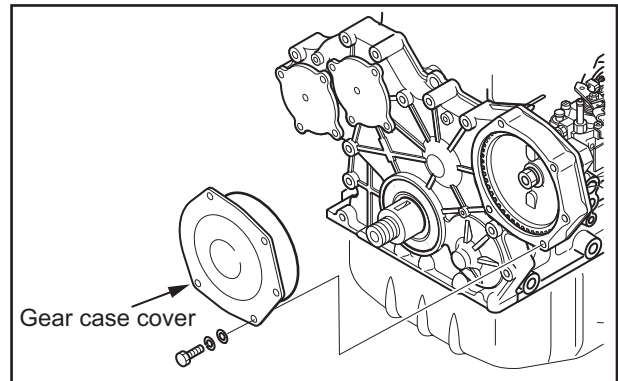

Installing gear case cover

Removal and Installation

Mast and Lift Bracket Assembly

Simplex Mast Removal

Note: For replacing mast roller without removing mast from track, refer to page 16.

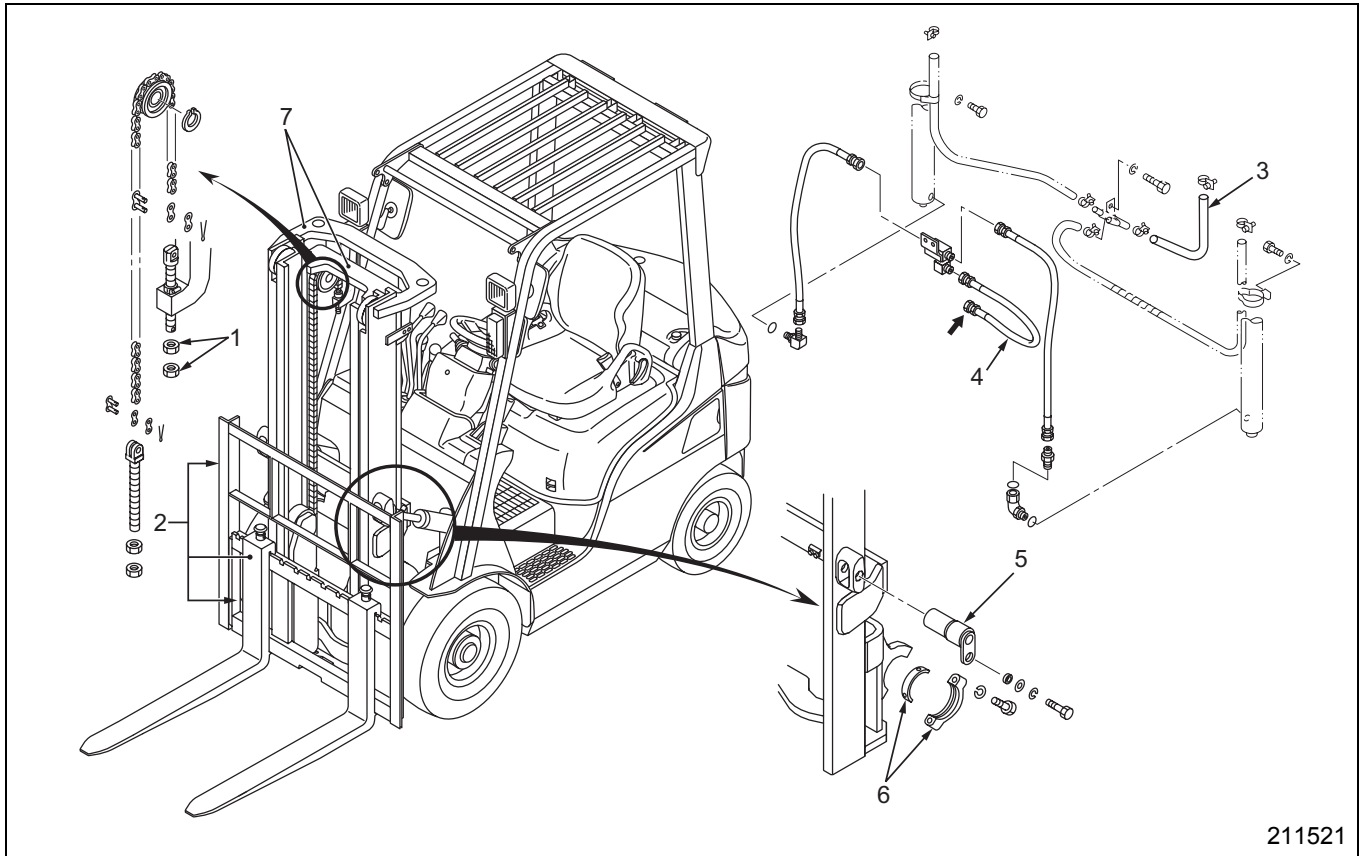

211521

Sequence

- | | |
|---------------------------------|---|
| 1 Nuts | 5 Tilt socket pin |
| 2 Backrest, Lift bracket, Forks | 6 Mast support bearing cap, Bushing |
| 3 Return hose (hi-lift model) | 7 Inner mast, Outer mast, Lift cylinder |
| 4 High-pressure hose | |

Suggestions for Removal

1. Removing lift bracket

- (1) Tilt the mast forward, and lower the inner mast to the bottom. Slacken the lift chains, and remove the nuts 1 from the anchor bolts.
- (2) Tilt the mast back to vertical position. Raise the inner mast until the lift bracket 2 becomes free. Then, slowly back the truck away, from the lift bracket and fork assembly.

Note: Before proceeding any mast overhaul, measure the clearance between mast and rollers. Knowing which roller should be replaced or which shims need adjustment in advance allows efficient maintenance work.

CLICK HERE TO **DOWNLOAD** THE COMPLETE MANUAL

- Thank you very much for reading the preview of the manual.
- You can download the complete manual from: www.heydownloads.com by clicking the link below



- Please note: If there is no response to CLICKING the link, please download this PDF first and then click on it.

CLICK HERE TO **DOWNLOAD** THE COMPLETE MANUAL