



# Operation & Maintenance Manual

## MC/FC

<b>GP15N</b>	T25C-55001-up	<b>DP15ND</b>	T16D-54001-up	<b>DP20NTS</b>	T18C-20001-up
<b>GP15ZN</b>	T34-52001-up	<b>DP15NT</b>	T16D-54001-up	<b>DP20N</b>	T18C-40001-up
<b>GP18N</b>	T25C-75001-up	<b>DP15NDS</b>	T16D-54001-up	<b>DP25ND</b>	T18C-70001-up
<b>GP18ZN</b>	T34-72001-up	<b>DP15NTS</b>	T16D-54001-up	<b>DP25NT</b>	T18C-70001-up
<b>GP20CN</b>	T34-22001-up	<b>DP15N</b>	T16D-64001-up	<b>DP25NDS</b>	T18C-70001-up
<b>GP20N</b>	T17D-10001-up	<b>DP18ND</b>	T16D-74001-up	<b>DP25NTS</b>	T18C-70001-up
<b>GP20ZN</b>	T35-10001-up	<b>DP18NT</b>	T16D-74001-up	<b>DP25N</b>	T18C-90001-up
<b>GP25N</b>	T17D-60001-up	<b>DP18NDS</b>	T16D-74001-up	<b>DP30ND</b>	T14E-10001-up
<b>GP25ZN</b>	T35-60001-up	<b>DP18NTS</b>	T16D-74001-up	<b>DP30NT</b>	T14E-10001-up
<b>GP30N</b>	T13F-40001-up	<b>DP18N</b>	T16D-84001-up	<b>DP30NDS</b>	T14E-10001-up
<b>GP35N</b>	T13F-60001-up	<b>DP20CND</b>	T16D-24001-up	<b>DP30NTS</b>	T14E-10001-up
<b>GPE15N</b>	T34-00001/19001-up	<b>DP20CNT</b>	T16D-24001-up	<b>DP30N</b>	T14E-20001-up
<b>GPE18N</b>	T34-40001/49001-up	<b>DP20CNDS</b>	T16D-24001-up	<b>DP35ND</b>	T14E-80001-up
<b>GPE20CN</b>	T34-30001/39001-up	<b>DP20CNTS</b>	T16D-24001-up	<b>DP35NT</b>	T14E-80001-up
<b>GPE20N</b>	T17D-20001/38001-up	<b>DP20CN</b>	T16D-28001-up	<b>DP35NDS</b>	T14E-80001-up
<b>GPE20ZN</b>	T35-20001/38001-up	<b>DP20ND</b>	T18C-20001-up	<b>DP35NTS</b>	T14E-80001-up
<b>GPE25N</b>	T17D-70001/88001-up	<b>DP20NT</b>	T18C-20001-up	<b>DP35N</b>	T14E-90001-up
<b>GPE25ZN</b>	T35-70001/88001-up	<b>DP20NDS</b>	T18C-20001-up		
<b>GPE30N</b>	T13F-10001/20001-up				
<b>GPE35N</b>	T13F-80001/90001-up				

Original Instructions

Keep this manual in your lift truck as a ready reference

99710-36120

CLICK HERE TO **DOWNLOAD** THE COMPLETE MANUAL

- Thank you very much for reading the preview of the manual.
- You can download the complete manual from: [www.heydownloads.com](http://www.heydownloads.com) by clicking the link below



- Please note: If there is no response to CLICKING the link, please download this PDF first and then click on it.

CLICK HERE TO **DOWNLOAD** THE COMPLETE MANUAL

## ■ SAFETY RULES FOR LIFT TRUCK OPERATORS

### ◆ General

The safety rules and regulations in this section are representative of some, but not all rules and regulations that apply to lift trucks. Rules are paraphrased without representation that they have been reproduced verbatim.

Your lift truck was manufactured in accordance with the National Fire Protection Association (NFPA) No. 505 and the American National Standards Institute, Inc. / Industrial Truck Standards Development Foundation (ANSI/ITSDF) B56.1, Safety Standard for Low and High Lift Trucks. Operate this lift truck in accordance with local regulations.

See [www.itsdf.org](http://www.itsdf.org) web site for more information on the B56.1 Safety Standards for Low Lift and High Lift Trucks.

The most effective way of reducing the risk of serious injuries, or even death, to you and others, is for you to know how to operate the lift truck properly. Drive alertly and avoid maneuvers or conditions that could cause accidents.

Be professional.

Do not operate a lift truck if it is in need of maintenance, repair or appears to be unsafe in any way. Report all unsafe conditions immediately to your supervisor, then contact your authorized lift truck dealer.

Do not attempt any adjustments or repairs unless you are trained and authorized to do so.

Continuing improvement and advancement of product design may have caused changes to your lift truck, which are not included in this publication. Whenever a question arises regarding your lift truck, or this publication, please consult your authorized Cat Lift Truck dealer for the latest available information.

All forklift truck users should be familiar with their Local, Regional, and National regulations.

**► Engine Coolant Decal**

**⚠ CAUTION**

- (1) Do not remove radiator filler cap except when changing coolant.
- (2) Do not remove radiator filler cap when coolant is hot.
- (3) Check coolant level and refill at reserve tank.
- (4) Maintain coolant level between FULL and LOW marks on reserve tank when coolant is cold. (Coolant level above FULL mark on reserve tank is not abnormal when coolant is hot.)

**REFILLING**

- (1) Remove radiator filler cap (pressure valve) and refill up to top of filler neck.
- (2) After refilling, tighten radiator filler cap (pressure valve) securely.
- (3) Remove reserve tank filler cap and refill up to FULL mark on reserve tank.
- (4) After refilling, tighten reserve tank filler cap securely.

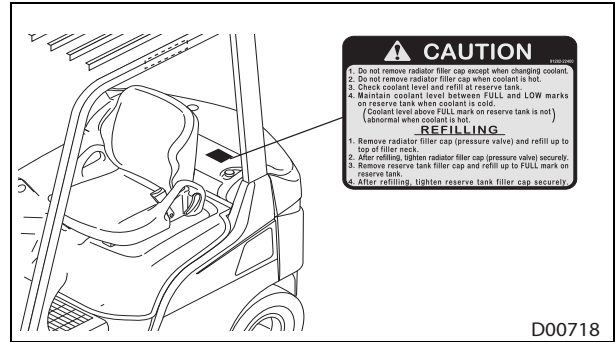

**► Parking Brake Adjustment Decal**

**⚠ WARNING**

- When leaving machine, apply parking brake! Parking brake is not automatically applied.
- ALARM will sound if parking brake is not applied when get off the truck or turn off the key switch.
- Adjust parking brake lever properly. See operation & maintenance manual for more important information.

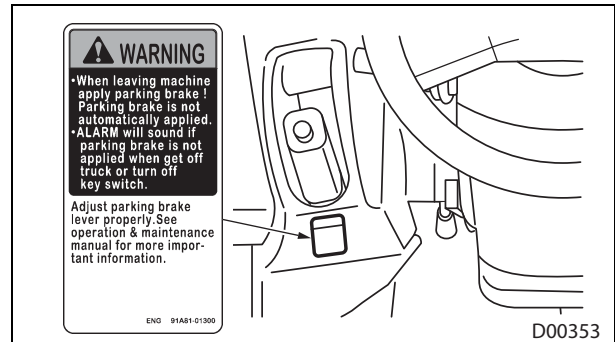

Model	Operating Force
1 ton model	150 to 200 N (15 to 20 kgf) [33 to 44 lbf]
2 ton model	200 to 250 N (20 to 25 kgf) [44 to 55 lbf]
3 ton model	230 to 250 N (23 to 25 kgf) [50 to 55 lbf]

**► Radiator Cap**

**⚠ WARNING**

Check the coolant level only after the engine has been stopped and the filler cap is cool enough to touch with your hands. Remove the filler cap slowly to relieve pressure.

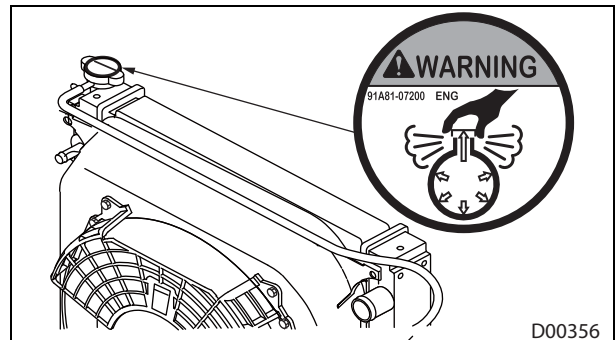

**⚠ WARNING**

**Avoid off-center loading!**

Set the forks as far apart as possible for maximum support of the pallet or load. Too small of a fork spread could cause instability of the load. **DO NOT** pick up an off-center load.

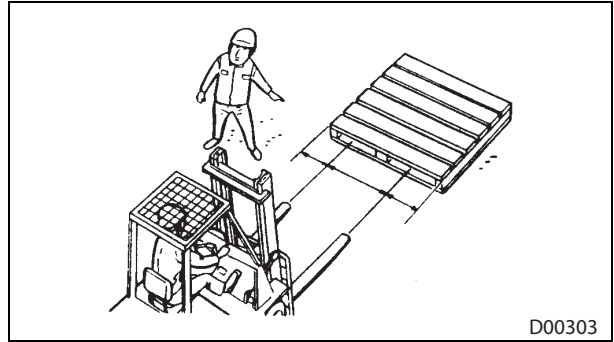

**⚠ WARNING**

**Stay under the overhead guard!**

**DO NOT** hold on to the overhead guard.

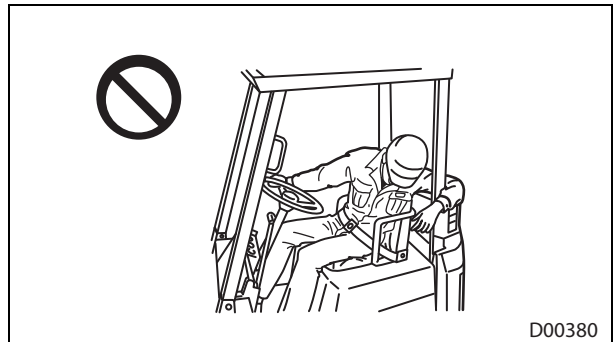

**⚠ WARNING**

**Check fork locking pins for engagement!**

If the fork locking pins are not properly engaged, nor in good repair, the forks could shift and cause off-center or unstable loads.

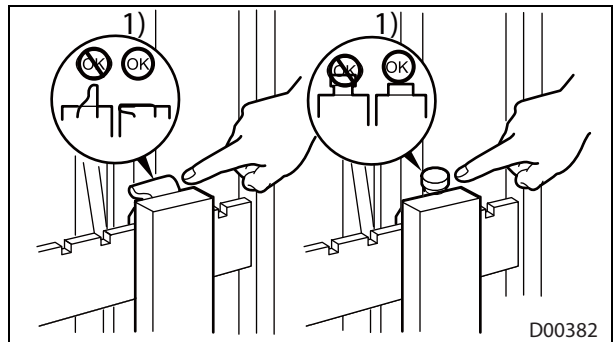

1) OK

**⚠ WARNING**

**Be careful of forks that extend beyond the load!**

If the forks extend beyond the load, use extra caution. Make sure the fork tips do not contact other material.

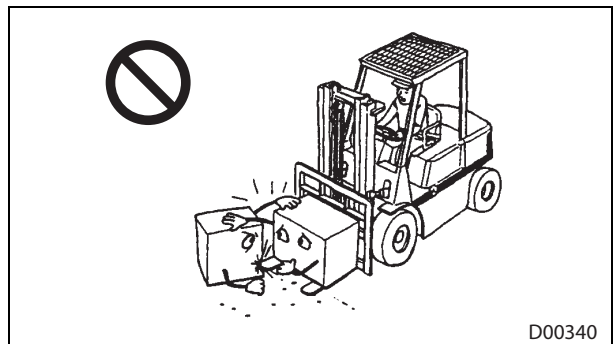

## ⚠ WARNING

### Inspect a trailer before entering!

- The brakes on the highway trucks or trailers must be applied, and wheel chocks or other positive mechanical means must be used to prevent unintentional movement of highway trucks and trailers.
- DO NOT travel along the edge of the dock. Lift Truck may fall off the dock.
- Before starting work, check the allowable load of dockplate, and if it does not have enough strength to withstand the weight of the lift truck carrying a load, do not use it.
- When entering trailer, use outriggers, (if equipped) so that the trailer will not sink.
- Travel slowly on dockplate when entering or exiting trailers or rail cars.
- Ask the driver of the trailer not to move the trailer until the work is completed.
- Use any anchoring equipment available in the dock to secure the trailer or rail car, and also secure the dockplate to prevent it from falling off.
- Obey the instructions of the supervisor when working as a team.

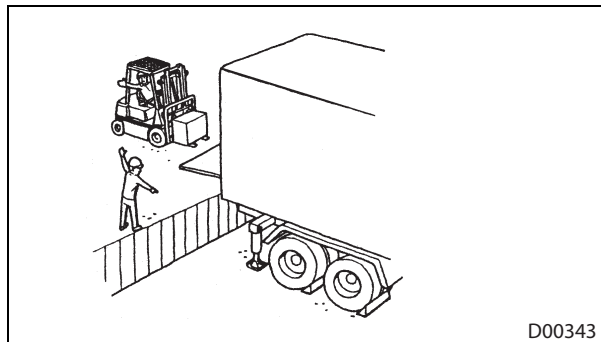

## ⚠ WARNING

### Operation of fork positioner! (if equipped)

- DO NOT operate the fork positioner while carrying loads.
- DO NOT handle off-center loads.

## ⚠ WARNING

### Operation of side shift! (if equipped)

When picking up loads, be sure to position the load in the center before moving the lift truck.  
DO NOT side shift while traveling with loads.

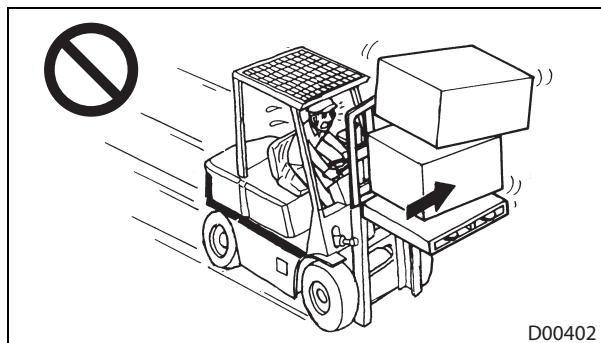

## ⚠ WARNING

DO NOT raise or lower a load while side shifting, as it is dangerous.  
DO NOT side shift the forks with the load raised higher than 150 cm unless safety is assured by the load stack or carrier deck just below the forks.

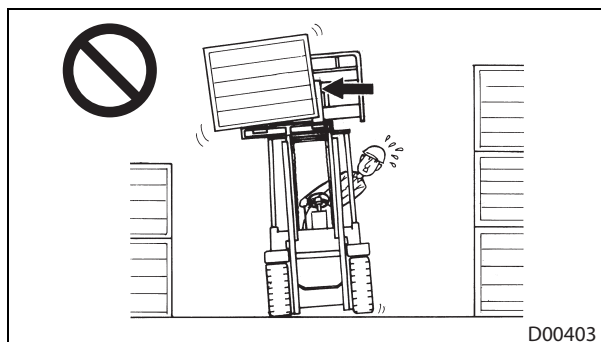



**► Basic Operation**

**Operation buttons**

The operation buttons are located on the right side of the meter panel. There are three types of buttons; ▲ button, ▼ button and ● button. The function/operation of these three buttons varies with each display screen.

Button operation is available only when the key switch is in the I (ON) position.

Some changes to the display are not available when the engine is running.

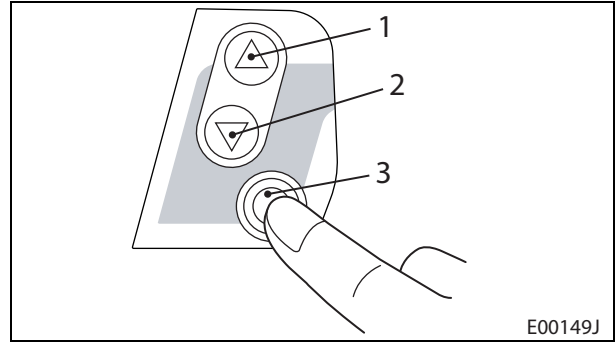

- 1. ▲ button
- 2. ▼ button
- 3. ● button

Note: Adjustment of screen contrast and selection between hour meter display and time display will operate with the engine running.

**Short press of button:**

Press button for less than two seconds.

**Long press of button:**

Press button for more than two seconds.

**Multiple button presses:**

All buttons pressed at the same time for more than two seconds.

**How to adjust screen contrast**

Turn the key switch to the I (ON) position. Adjustment of screen contrast is available while the engine is running.

Button	Press	Screen contrast
▲	Short press	Light to Dark
▼		Dark to Light

The screen contrast varies with the number of times a button is pressed.

**How to display clock time**

Turn the key switch to the I (ON) position. Screen display selection is available while the engine is running. With a short press of the ● button, the display changes between the clock time and the hour meter.

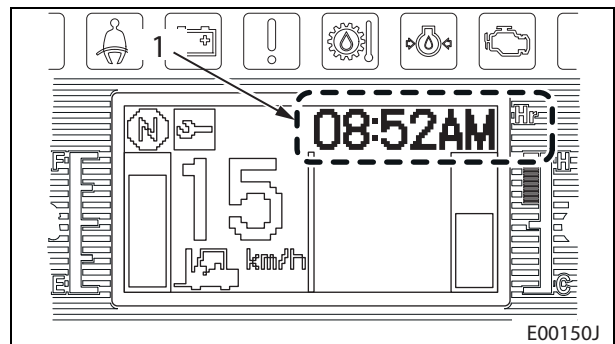

- 1. Clock time / Hour meter

Button	Press	Screen contrast
●	Short	Hour meter ↔ Clock time

**◆ Presence Detection System**

Lift trucks with this label are equipped with an "Presence Detection System" (PDS). This system features an enhanced, integral computer-based feed back system which provides "certain product intelligence" to the operator.

Be sure to operate the lift truck and system correctly. Also be sure to properly maintain as well as operate the system at all times.

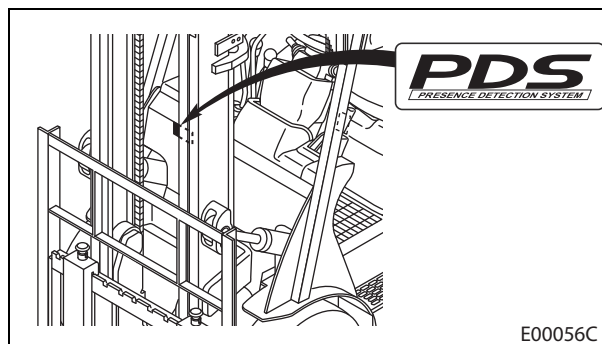

**► Mast Interlock System**

When the operator leaves the operator seat for 3 seconds while the engine is running, the operator presence switch in the operator seat is activated, which causes the mast to be irresponsive, even if the operating control levers (lift, tilt and attachments) are operated.

Note: There may be a difference in start-up time of the mast interlock operation depending on the condition of how the control levers (lift, tilt and attachments) are operated and the mast's and attachments' specifications.

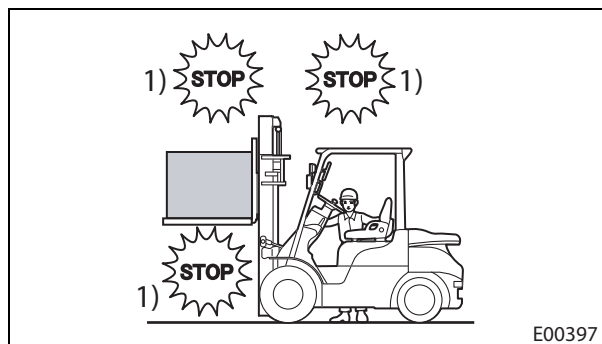

1) STOP

**Mast Interlock System Functions**

Key Switch	Engine	Operator Seat	Mast Interlock Indicator Lamp	Operating Control Lever (MC)		Operating Control Lever (FC)	
				Lift Lever	Tilt Lever	Lift Lever	Tilt Lever
○ (OFF)	Stop	Seated	OFF	Not Active	Not Active	Active	Not Active
		Not Seated	OFF	Not Active	Not Active	Active	Not Active
(ON)	Stop	Seated	OFF	Lowering only	Not Active	Active	Not Active
		Not Seated	Glow	Not Active	Not Active	Active	Not Active
⊞ (START)	Running	Seated	OFF	Active	Active	Active	Not Active
		Not Seated	Glow	Not Active	Not Active	Active	Not Active

**⚠ WARNING**

- Check the function of the mast interlock system at the daily pre-start inspection.
- Even when the engine is not running, while the operator is sitting correctly in the operator seat and with the key switch in the | (ON) position, it is possible for the mast to descend. Please be very careful. (See the table above.)
- The parking brake is not automatically applied when the interlock is activated.
- When changing the operator seat, BE SURE to select a genuine Cat Lift Truck seat with an operator presence switch and an operator restraint system.

**► Forward and Back Adjustment Stopper Knob**

**⚠ CAUTION**

DO NOT insert fingers under this box at the front or rear when adjusting the FC lever box forward or backward.

- (1) Loosen the knob to unlock with LEFT HAND.
- (2) In order to adjust the FC lever box to an appropriate forward and back position, push forward with RIGHT HAND.
- (3) Tighten the knob to lock with LEFT HAND.
- (4) Make sure that the box is firmly secured.

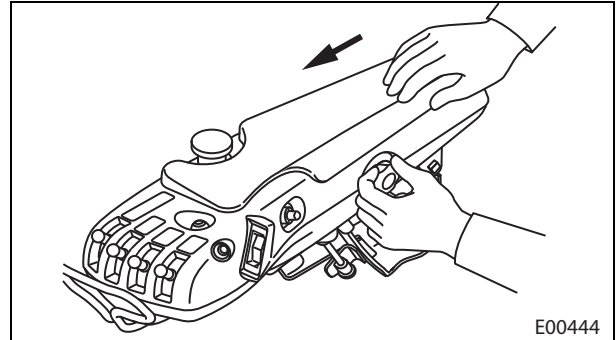

**► Up and Down Adjustment Stopper Knob**

**⚠ CAUTION**

DO NOT place fingers around the gas springs or insert fingers into the slot of the adjuster when adjusting the FC lever box up or down.

- (1) Loosen the knob to unlock with LEFT HAND.
- (2) In order to adjust the FC lever box to an appropriate height, push down with RIGHT HAND. The box is assisted with gas springs.
- (3) Tighten the knob to lock with LEFT HAND.
- (4) Make sure that the box is firmly secured.

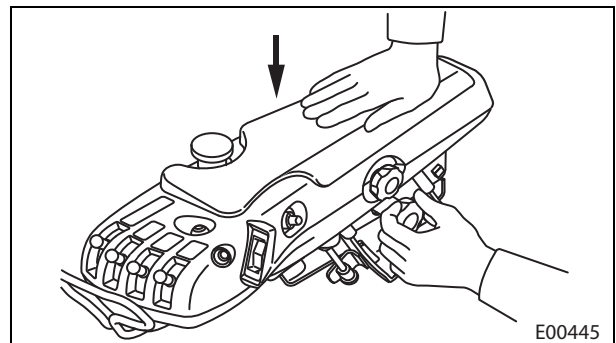

**► Direction Switch (Optional)**

- Flip the lower switch for forward driving.
- Flip the upper switch for reverse driving.

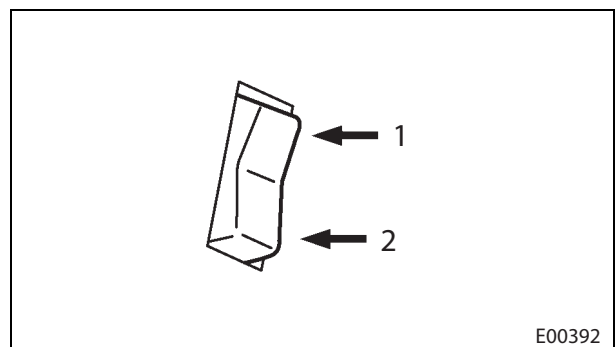

1. Backward

2. Forward

**◆ Drawbar Pin**

Use the drawbar pin for the following situations:

- Pulling the lift truck out of a drop-off or ditch.
- Loading and unloading the lift truck on a transport truck.
- When loading the lift truck on a hauling track by using the drawbar pin, start the engine, and release the parking brake lever.

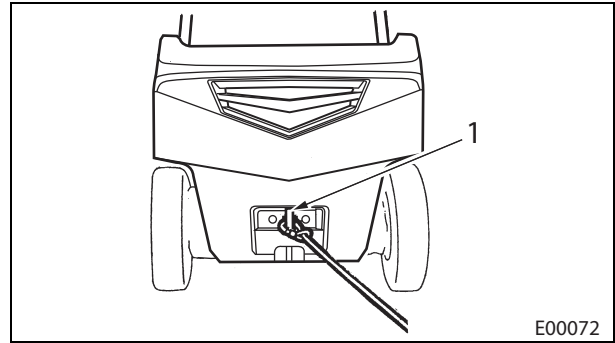

1. Drawbar pin

**⚠ WARNING**

DO NOT use the drawbar pin for towing loads.

**⚠ WARNING**

**Precautions for the use of the drawbar pin**

- When hitching a cable to the pin, make sure the pin is inserted safely.
- Take up slack slowly---DO NOT jerk. Keep the cable taut. If the cable has slack, the sudden impact of the load could snap it, resulting in an accident.
- A helper must stand at a safe distance and watch the pin. Stop pulling with the lift truck, relieve tension, and reduce load if the pin starts to come out.

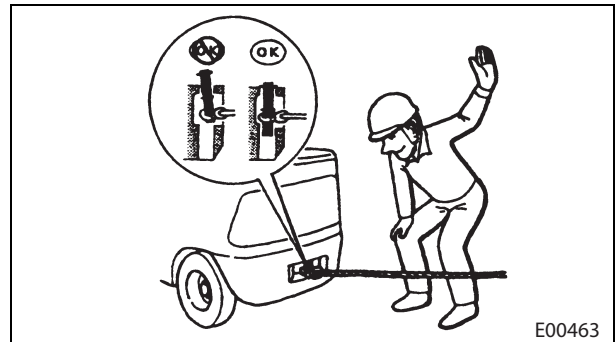

**◆ Assist Grip**

Grasp the assist grip with the left hand, the seat backrest with the right hand, and step up with the left foot to get on the lift truck safely.

**⚠ WARNING**

- DO NOT hold the steering wheel or the control lever.
- DO NOT jump on or off the lift truck.

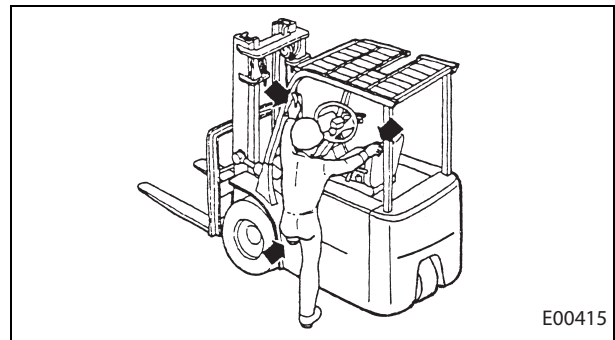

### ◆ LP-Gas Equipped

#### ⚠ WARNING

BE SURE to use the proper fuels specified in the 12-1 "SERVICE DATA". If not, the engine could fail.

#### ⚠ WARNING

- Only trained and authorized personnel must fill or exchange LP-Gas tanks.
- Personnel engaged in filling LP-Gas tanks must wear protective equipment such as a face shield, long sleeves and gauntlet gloves.
- DO NOT refuel or store LP-Gas powered lift trucks near underground entrances, elevator shafts, or other places where LP-Gas could collect in a pocket and cause an explosion.
- Inspect all LP-Gas tanks before filling, and again before reuse for damage to the valves, liquid gauge, fittings and hand wheels.
- All defective or damaged LP-Gas tanks must be removed from service.
- The careless handling of LP-Gas tanks could result in a serious accident.
- To reduce the risk of damage to tanks, use extreme care when transporting them.

#### ⚠ WARNING

The LP-Gas tank must not extend past the counterweight and must be inside the confines of the lift truck.

#### ⚠ WARNING

##### **Reduce the risks of fire caused by static electricity!**

Touch grounded metals with bare hand to discharge the static electricity before changing compressed LP-Gas tanks. If not, the fuel could catch fire due to the static electrical spark.

#### ⚠ CAUTION

LP-Gas tanks can be heavy, follow the instructions below:

- DO NOT insert fingers into the straps or brackets. If this warning is not adhered to, fingers may be pinched.
- DO NOT lift LP-Gas tank with your body in an improper position. You may injure your back.
- Take care not to drop an LP-Gas tank. It may fall on your body and lead to serious injury including bone fractures.
- Wear appropriate personal protective equipment.

#### ⚠ CAUTION

Be careful not to pinch fingers in the bands when installing a LP-Gas tank.

Note:

- MOUNT THE TANK PROPERLY. To insure full usage of fuel, use the mounting holes located on the collar for horizontal mounting and the slot in the foot ring for vertical mounting.
- Open the valve slowly so that hose and tank pressure can equalize. Or the valve may shut off.
- For proper operation of LP-Gas system, use HD-5 LPG fuel.

## OPERATION

### ► When Engine Is Started after Long Idle Period

#### Gasoline engine model

- (1) Press the accelerator pedal several times and release the pedal fully.

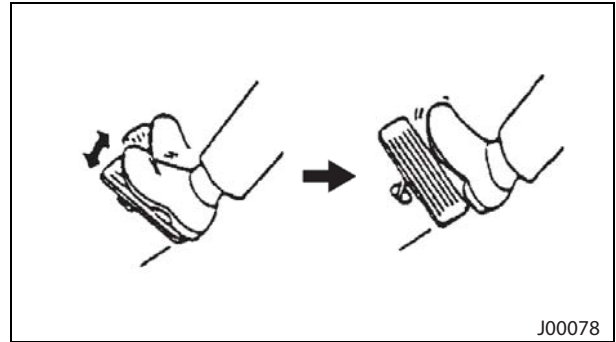

- (2) Turn the key switch to the  (START) position.

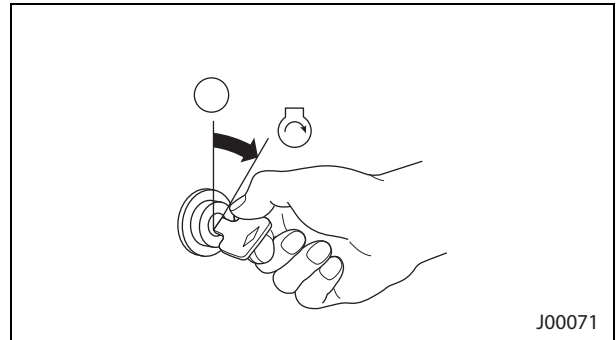

Note: The head lamps should be turned OFF for easier starting.

#### Diesel engine model

Air in the fuel system may cause starting failure. In this case, have your authorized Cat Lift Truck dealer prime the fuel system or check the fuel system for possible problems.

### ◆ After Starting Engine

#### ⚠ WARNING

If the warning lamp comes on, correct the problem before operating the lift truck. Contact your authorized Cat Lift Truck dealer for repairs.

#### ⚠ CAUTION

- BE SURE to warm up the engine regardless of the weather.
- If the engine is not warm up, it may cause poor lubrication and incomplete fuel combustion resulting in poor engine performance.

Check the warning lamps and gauges frequently during operation to make sure all systems are working properly.

- (1) Run the engine at idle speeds without a load for about 5 minutes.
- (2) During warm-up, check to see that systems are operating properly.
  - Are all the warning lamps OFF?
  - Are exhaust noise and smoke color normal?
  - No excessive vibration?

**⚠ WARNING**

**Get off safely**

- Get off after the lift truck has come to a complete stop and 5-17 "Parking Lift Truck (After Stopping)" has been followed.
- DO NOT jump off.

**⚠ WARNING**

DO NOT pick up an off-center load. Make sure the weight of the load is centered between the forks.

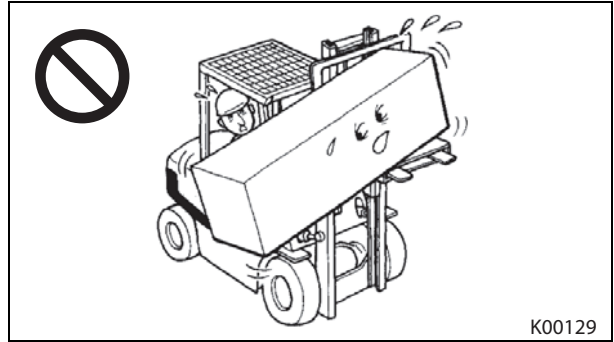

- (9) Look around to make sure your drive area is clear.
- (10) Honk horn.
- (11) Place the direction lever in the BACKWARD position and change the direction to the work place.
- (12) Place the direction lever in the FORWARD position and move the lift truck into the work place.

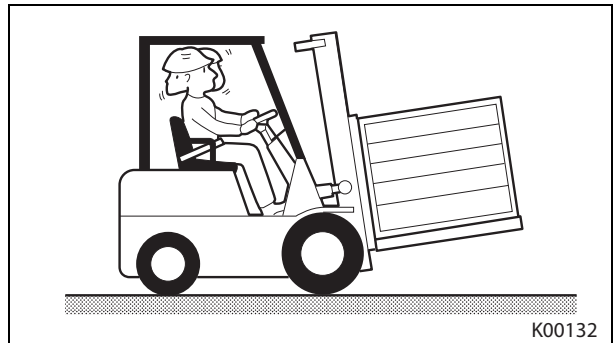

**⚠ WARNING**

If the load blocks your view, or when you travel down a grade with the load, drive in REVERSE. Always look in the direction of travel.

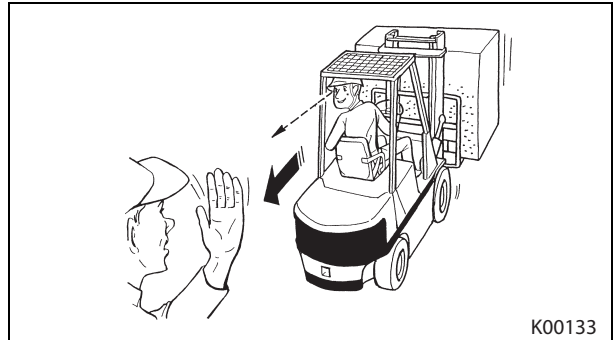

## SPECIAL SITUATIONS

### ► Engine Coolant

- Antifreeze used in the engine cooling system of a new lift truck shipped from the manufacturer provides sufficient freeze protection to  $-30^{\circ}\text{C}$  ( $-22^{\circ}\text{F}$ ).
- If ambient temperatures are below  $-30^{\circ}\text{C}$  ( $-22^{\circ}\text{F}$ ), add antifreeze.

Note: For type and concentration of antifreeze, consult your authorized Cat Lift Truck dealer.

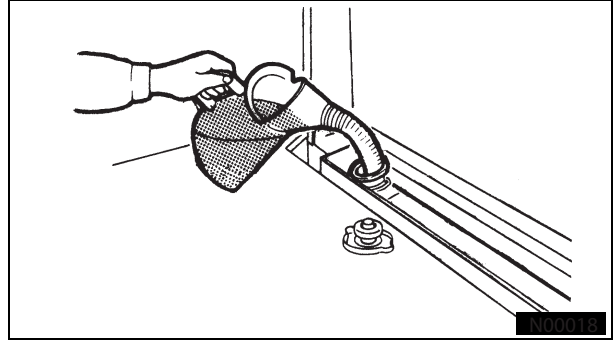

### ◆ Care in Hot Weather

#### ► Fuel Oils and Lubrication Oils

Use fuel oil, engine oil and gear oil to fit the ambient temperatures.

Note: For selection of fuel oil, engine oil and gear oil, consult your authorized Cat Lift Truck dealer.

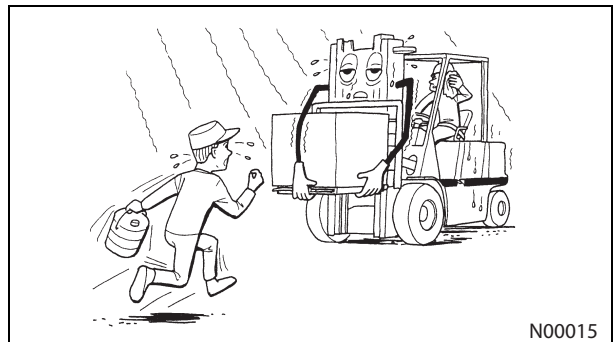

#### ► Battery

In hot and/or dry weather, check the battery cells for proper electrolyte level more often than in cold weather. Add distilled water whenever the level is low.

#### ► Engine Coolant

### ▲ WARNING

Be careful NOT to have scalding hot coolant or steam blow out of the reserve tank. Remove the radiator cap only after engine cools.

Note: Coolant evaporates rapidly and the engine is likely to get overheated when the lift truck is operated continuously or on a grade. During such an operation, observe the engine coolant temperature gauge for symptoms of overheating.

### ▲ CAUTION

If the engine coolant temperature gauge shows the red zone, the engine may be overheated.

Note: If the engine coolant temperature gauge shows the red zone, refer to "Engine Coolant Temperature Gauge Shows Red Zone."

## ◆ If Torque Converter Oil Temperature Warning Lamp Glows (Powershift)

- (1) Stop the lift truck in a non-traffic area.
- (2) Set the parking brake.
- (3) Place the direction lever in the NEUTRAL position.
- (4) Run the engine at low idle for a while.
- (5) After the warning lamp has gone out, operate the lift truck again.

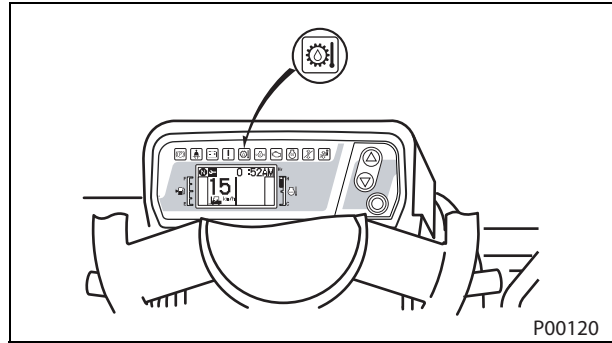

### ⚠ CAUTION

If the warning lamp does not go out, or if it constantly glows, consult your authorized Cat Lift Truck dealer.

## ◆ Trouble with the LP-Gas Equipment

### ⚠ WARNING

- If you smell gas or notice something wrong with LP-Gas equipment during operation, immediately stop the lift truck in a safe area, turn the key switch to the ○ (OFF) position, close the fuel valve of the LP-Gas tank, and try to find the cause. (It is recommended that the fuel lines and fittings be checked with a soap solution after filling the tank or when looking for leaks.)
- If the internal pressure of the LP-Gas tank rises too high and causes the relief valve to open to let out the excess pressure, sprinkle water over the tank. At the same time, extinguish any fire or flame source (such as a pilot lamp) and eliminate the possibility of creating sparks near the lift truck. Ventilate the work place.
- When gas leakage is evident, close the fuel valve as soon as possible. Extinguish the fire or flame sources nearby to prevent spark conditions.
- There is a possibility of fire after a collision or when the lift truck turns over. If this happens, close the LP-Gas fuel valve of the LP-Gas tank as soon as possible.
- Use a dry chemical (powder) or carbon dioxide type extinguisher. DO NOT use water. When possible, however, have large quantities of water poured over the LP-Gas tank to cool it down while the fire is being extinguished.

## ◆ Inspection Precautions

### ⚠ WARNING

If the lift truck requires any repair, attach a "DO NOT OPERATE" or similar warning tag to the steering wheel or other controls, remove the key from the key switch, and contact your authorized Cat Lift Truck dealer.

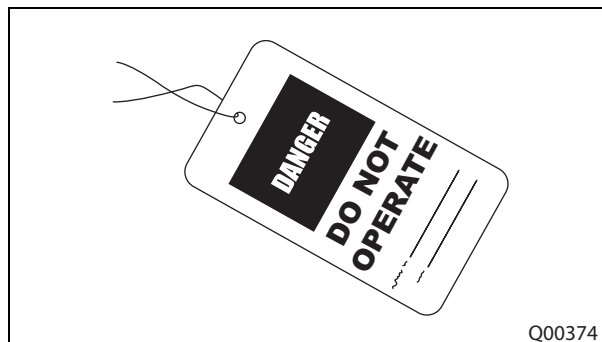

### ⚠ WARNING

If it is necessary to make an inspection while the engine is running, ALWAYS USE TWO WORKERS---one, the operator, at the controls and the other checking within visual contact of the operator.

### ⚠ CAUTION

A daily (Pre-Start) inspection is the key to safety. At the beginning of each shift, check your lift truck to make sure it is in a safe operating condition. Always inspect your lift truck under the following conditions.

- Lift truck on level ground
- Mast in vertical position
- Fork tips on ground
- Engine stopped
- Control levers in neutral.
- Wheels blocked.

### ⚠ CAUTION

- Avoid mixing lubricants. In some cases, different brands of lubricants are not compatible with each other and deteriorate when mixes. It is best to stick with the same brand at successive service intervals.
- Before refilling, clean filler holes. After filling, clean up spills.

### ⚠ CAUTION

Consult your authorized Cat Lift Truck dealer for the proper disposal of wastes accumulated after replacement of tires, batteries, oils and fluids.

**► Wheel Nuts**

**Check--Tighten When Required**

Wheel nuts should be visually inspected everyday. Any loose nuts should be tightened and any missing or damaged nuts should be changed.

- Are the wheel nuts tightened properly?  
Use a torque wrench.

**How to retighten**

- (1) Always stand behind the tread of the tire, NOT in front of the rim.
- (2) Tighten the nuts evenly and in a diagonal sequence to the specified torque.

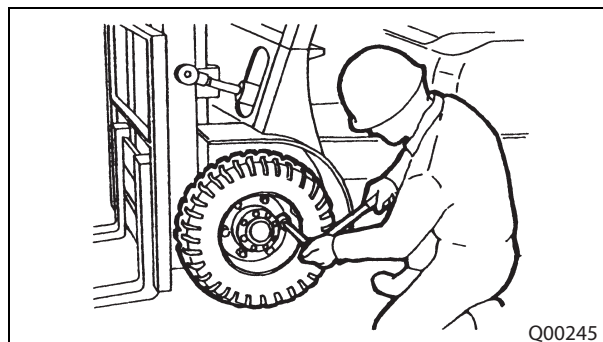

**Tightening torques for wheel nuts**

<b>Models</b>	<b>Side</b>	<b>Torque</b>
1 to 2 ton compact	Front	157 N·m (16 kgf·m) [116 lbf·ft]
	Rear	
2 to 3 ton	Front	378 N·m (38.5 kgf·m) [279 lbf·ft]
	Rear: 2P	
	157 N·m (16 kgf·m) [116 lbf·ft]	
	Rear: 4P	
233 N·m (23.8 kgf·m) [172 lbf·ft]		
3.5 ton	Front	378 N·m (38.5 kgf·m) [279 lbf·ft]
	Rear	233 N·m (23.8 kgf·m) [172 lbf·ft]

## How to add engine oil

### ⚠ WARNING

When adding engine oil:

- Perform the work on level ground.
- Clean the filler hole to prevent dirt from dropping into the engine.
- DO NOT overfill.
- Clean up spillage.

(1) Remove the oil filler cap.

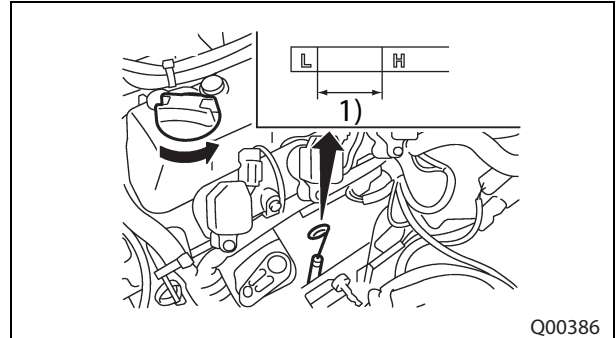

1) Correct level range

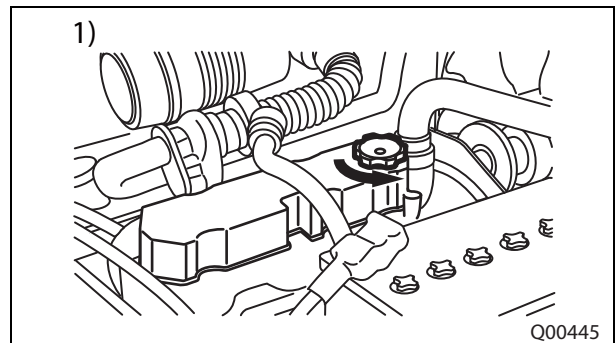

1) DIESEL

- (2) Add engine oil as required.  
For engine oil, refer to "Recommended Fuels and Oils."
- (3) After adding oil, make sure the level is in the correct range on the dip stick.
- (4) Close and tighten the filler cap.

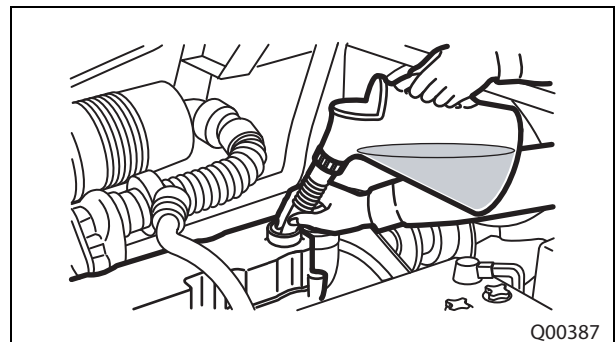

### ► Engine Cooling Fan

#### Check

- Check for damage and rotation.

## MAINTENANCE

### ► Brake Pedal

- Do the brakes apply and stop the truck properly without pulling, dragging, chattering, squealing?



- Check if the lift truck stops when pulling the parking brake lever on a grade.

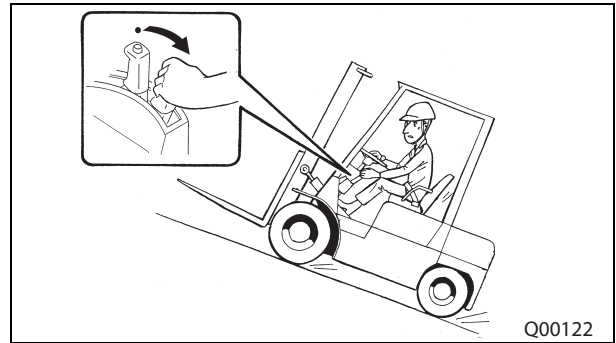

### ► Steering Wheel

Check the condition of steering wheel.

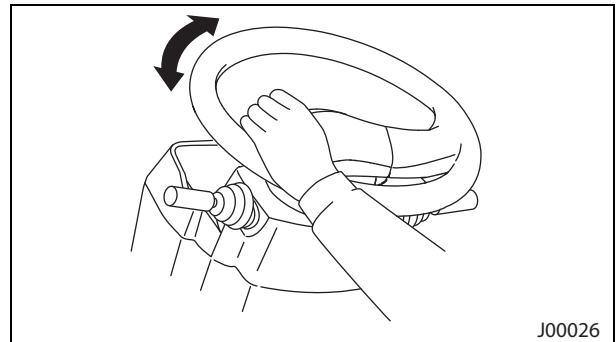

## MAINTENANCE

- (1) Raise the engine hood.
- (2) Unclamp the dust cup (at 3 places) and take out the element.
- (3) Clean the inside of the air cleaner housing.
- (4) Direct air inside the element along the pleats, and lightly tap it.
- (5) Insert a light inside a clean element and check.
- (6) Replace the element if tears or rips are found.
- (7) Install the air cleaner element.
- (8) Close the engine hood.

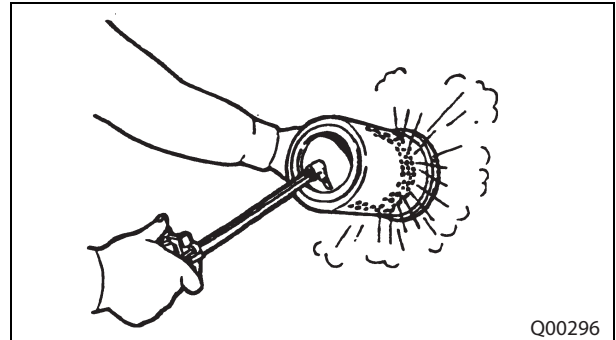
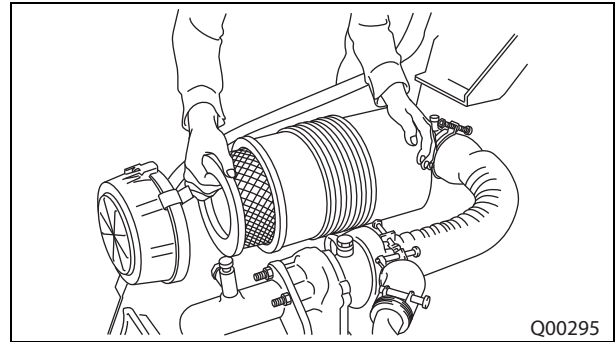

### Note:

- Double-cyclone cleaner element (optional) requires cleaning of its outer element only.
- DO NOT service the air cleaner with the engine running.
- DO NOT clean the elements by pounding them against another object.
- Always inspect the element before and after cleaning.
- After the fifth cleaning, you must change the air cleaner element even if it is within the scheduled maintenance period.
- Clean and change more frequently in corrosive or abrasive environments.

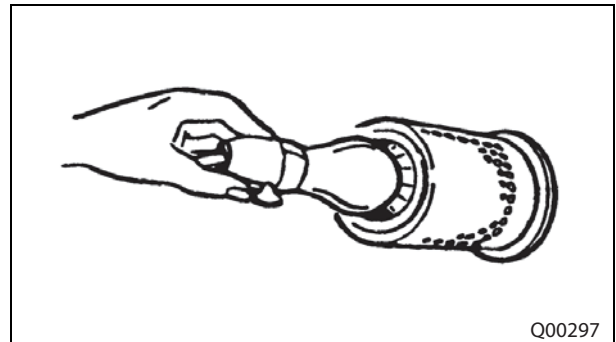

### ► Mast Strip Sliding Surfaces

#### Lubricate

Inspect the mast strip surfaces for wear and cracks.

- Does the mast and rollers move smoothly? If not, lubricate on each side of the inner mast.

For lubrication of mast strip sliding surfaces, have it done by your authorized Cat Lift Truck dealer.

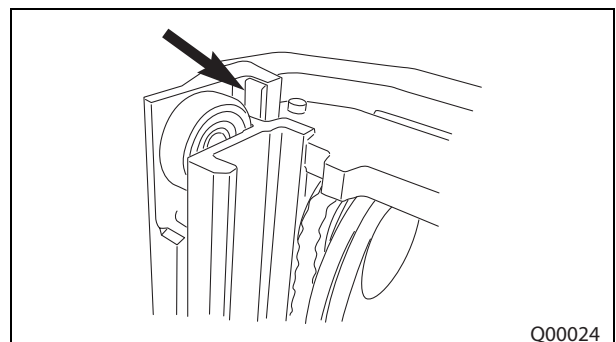

## MAINTENANCE

- (8) Wash the strainer in clean, nonflammable solvent.
- (9) Inspect the gasket and change it, if necessary.
- (10) Install the strainer, gasket and cover.

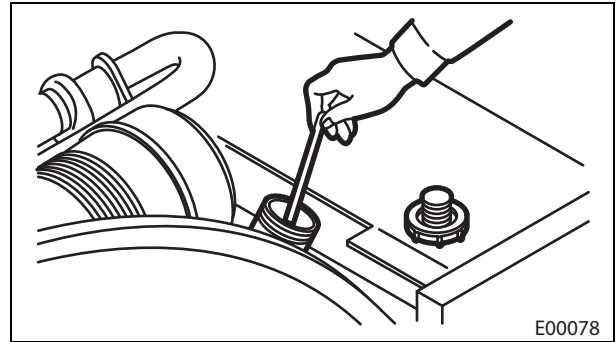

- (11) Remove the filler cap. Check the oil level.
- (12) Add oil, if needed, to reach the correct level range on the dip stick.
- (13) Install the dip stick.
- (14) Check for oil leaks.
- (15) Close and secure the engine hood.

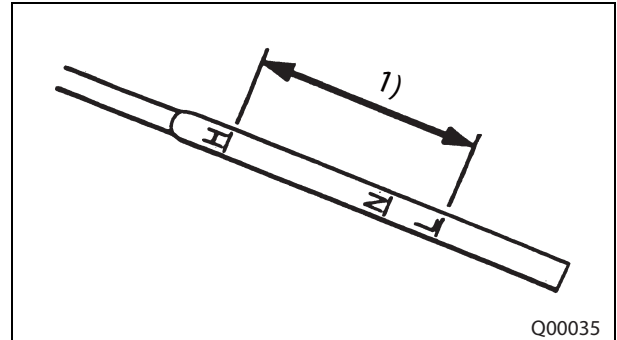

1) Correct level range

### ► Air Cleaner Element

#### Change

Mitsubishi Caterpillar Forklift Inc. strongly recommends that the air cleaner element be changed if it is dirty. If you attempt to clean the element, handle it carefully.

#### Recommended change intervals

Conditions	Interval
Normal Conditions	Every 1000 service hours or 6 months, whichever comes first
Severe Dust or Lint Conditions	Clean and change more frequently in corrosive or abrasive environments.

Note:

- Have spare elements available to use while cleaning used elements.
- In severe dust or lint conditions, check the radiator core frequently for clogging or dirt accumulation. Clean or wash the lift truck as needed. Refer to "Air Cleaner Element, Clean and Inspect" under "Every 50 Hours or Weekly, Whichever comes first."

**◆ Coolant Information**

The manufacturer recommends that the coolant mix contain 50% commercially available automotive antifreeze, and 50% water.

Note:

- To reduce the risk of damage to your engine, Do not add coolant to an overheated engine. Allow the engine to cool first.
- Dowtherm 209 full-fill coolant will lower the water pump cavitation temperature and boiling point. These lowered temperatures will cause overheating at a lower ambient temperature than an ethylene glycol and water mix. If Dowtherm is used, follow the instructions provided and use only the inhibitor package recommended by the supplier.
- If the lift truck is to be stored in, or shipped to, an area with freezing temperatures, the cooling system must be protected to the lowest expected outside (ambient) temperature. The engine cooling system is protected with a commercially available automotive antifreeze when shipped from the factory. In cold weather, check the specific gravity of the coolant frequently to ensure adequate protection.
- Clean the cooling system if it is contaminated, the engine overheats or foaming is observed in the radiator. Old coolant should be drained, the system cleaned and new coolant added---as recommended--- using a commercially available automotive antifreeze. Filling at over 20 liters per minute could cause air pockets in the cooling system.
- After draining and refilling the cooling system, run the engine with the radiator cap off. Run it until the coolant reaches its normal operating temperatures and the coolant level stabilizes.
- Add coolant as necessary to fill the system to the proper level. Operate with a thermostat in the cooling system all year round. Cooling system problems could arise without a thermostat.

**► Coolant Water**

The manufacturer recommends the use of distilled water or deionized water to reduce the potential and severity of chemical insolubility.

- Hard water, or water with high levels of calcium and magnesium ions encourages the formation of insoluble chemical compounds by combining with cooling system additives such as silicates and phosphates. The tendency of silicates and phosphates to precipitate out-of-solution increases with increasing water hardness.
- Hard water, or water with high levels of calcium and magnesium ions, encourages the formation of insoluble chemicals, especially after a number of heating and cooling cycles.
- Using water that meets the minimum acceptable water requirement may not prevent dropout of these chemical compounds completely but should control the dropout rate at acceptable levels.

<b>Acceptable Water</b>	
<b>Water Content</b>	<b>Limits (ppm)</b>
Chlorides (Cl)	50 ppm (maximum)
Sulfates (SO4)	50 ppm (maximum)
Total Hardness	80 mg/l
Total Solids	250 ppm (maximum)
pH	6.0 to 8.0

ppm = parts per million

## ■ TO THE CAT LIFT TRUCK OWNER

### ◆ The Importance of Genuine Parts

The dealers and the owners are urged to use ONLY genuine parts to maintain lift trucks in a safe and efficient operating condition. Safe and efficient operation of your lift truck could be endangered by the use of inferior parts. In most cases, imitations sold as cheap parts invariably could mean a short part life and a higher maintenance cost.

Genuine parts give safe and reliable performance.

### ▲ CAUTION

The damage caused by parts other than genuine parts is not covered by Cat Lift Trucks' warranty.

**CAT**<sup>®</sup>

DESCRIPTION

PART NUMBER LEVEL

QUANTITY 15341-1

MADE TO MCF SPECIFICATIONS IN:

R00008C

**1. SAFETY RULES FOR LIFT TRUCK OPERATORS ..... 1-1**

**General ..... 1-1**

**Warning Decals, Location..... 1-2**

**Decals for Dual Fuel Only ..... 1-4**

**Warning Decals, Description ..... 1-5**

- ▶ No One under / on Forks ..... 1-5
- ▶ Crush and Pinch Points ..... 1-5
- ▶ Tipover Warnings ..... 1-5
- ▶ With Overhead Guard Decal / Load Backrest Extension ..... 1-6
- ▶ Operator Restraint System Decal ..... 1-6
- ▶ Deflate Air Before Loosening Nut Decal ..... 1-6
- ▶ Precautions for Handling E.C.U Decal ..... 1-7
- ▶ Capacity Plate ..... 1-7
- ▶ Backup Alarm Decal ..... 1-7
- ▶ No Riders Warning Decal ..... 1-8
- ▶ Survive in a Tipover Decal ..... 1-8
- ▶ Operation Warning Decal ..... 1-9
- ▶ Engine Coolant Decal ..... 1-10
- ▶ Parking Brake Adjustment Decal ..... 1-10
- ▶ Radiator Cap ..... 1-10
- ▶ Cooling Fan ..... 1-11
- ▶ No Contamination Permissible Decal ..... 1-11
- ▶ Dual Fuel Instruction Decal ..... 1-11

**Safety Rules..... 1-12**

**Operating Precautions..... 1-22**

**Working Precautions ..... 1-27**

**LPG ..... 1-34**

**2. KNOW YOUR LIFT TRUCK ..... 2-1**

**Serial Number and Capacity Plate ..... 2-1**

**Electrical Components ..... 2-2**

**Model View..... 2-3**

- ▶ MC Model ..... 2-4
- ▶ FC Model ..... 2-4

**Driving Switches and Controls ..... 2-5**

- ▶ Direction Lever (Powershift Model) ..... 2-6
- ▶ Turn Signal / Light Switch ..... 2-6
- ▶ Key Switch ..... 2-7
- ▶ Steering Column Tilt Lever ..... 2-7
- ▶ Inching Pedal ..... 2-8

**Meter Panel ..... 2-9**

- ▶ Warning and Indicator Icons ..... 2-10
- ▶ LCD Screen ..... 2-10
- ▶ Warning Icons and Indicators ..... 2-11
- ▶ Basic Screen Display ..... 2-13
- ▶ Basic Operation ..... 2-16
- ▶ When diagnostic code is shown on display ..... 2-20
- ▶ Optional Functions ..... 2-21

**Presence Detection System..... 2-26**

- ▶ Mast Interlock System ..... 2-26
- ▶ Driving Interlock System ..... 2-27
- ▶ Driving Interlock System Functions (Powershift models only) ..... 2-28
- ▶ Neutral System ..... 2-28
- ▶ Neutral System Functions ..... 2-28
- ▶ Seat Belt Warning Icon ..... 2-29
- ▶ Seat Belt Warning Functions ..... 2-29
- ▶ Parking Brake Warning Buzzer and Alarm Icon ..... 2-29
- ▶ Parking Brake Warning Functions ..... 2-30

**Operating Switches and Controls (MC Model) ..... 2-31**

- ▶ Lift Lever ..... 2-31
- ▶ Tilt Lever ..... 2-31
- ▶ Mast Vertical Switch (Optional) ..... 2-32
- ▶ Attachment Lever (Optional) ..... 2-32

**Operating Switches and Controls (FC Model) ..... 2-33**

- ▶ Lift Switch ..... 2-33
- ▶ Tilt Switch ..... 2-34
- ▶ Attachment Switch A/B (Optional) ..... 2-34
- ▶ Selector Switch Between Forth and Fifth Attachment ..... 2-34
- ▶ Lowering Speed Selector Switch (Optional) ..... 2-34
- ▶ Other Controls ..... 2-35
- ▶ Emergency Mast Stop Button ..... 2-35
- ▶ Forward and Back Adjustment Stopper Knob ..... 2-36
- ▶ Up and Down Adjustment Stopper Knob ..... 2-36
- ▶ Direction Switch (Optional) ..... 2-36

**Operator Seat ..... 2-37**

- ▶ Seat Adjustment ..... 2-37
- ▶ Forward and Back Adjustment ..... 2-37
- ▶ Adjustment of Suspension ..... 2-38
- ▶ Reclining Angle Adjustment ..... 2-38
- ▶ Pocket for the Manual ..... 2-38
- ▶ Magazine Box ..... 2-38
- ▶ Operator Presence Switch and Buzzer ..... 2-39

**Seat Belt ..... 2-39**

**Engine Hood..... 2-41**

- ▶ Hood Latch ..... 2-41

**Hydraulic Tank Oil Level / Filler Hole..... 2-42**

**Fuel Filler ..... 2-42**

**Fork Locking Pins ..... 2-43**

**Replacing Forks ..... 2-44**

**Drawbar Pin ..... 2-44**

**Assist Grip ..... 2-45**

**3. HOW TO AVOID A TIPOVER; HOW TO SURVIVE ONE ..... 3-1**

**Know What Lift Truck Stability Is ..... 3-1**

**Center of Gravity (CG) ..... 3-1**

**Stability and Center of Gravity ..... 3-1**

**Lift Truck Stability Base..... 3-2**

**Capacity (Weight and Load Center)..... 3-2**

**Capacity Plate..... 3-3**

- ▶ For Example ..... 3-3

**Do's and Don'ts to Avoid Tipover ..... 3-3**

**How to Survive in a Tipover..... 3-8**

**4. REFUELING ..... 4-1**

**Gasoline and Diesel Engine Equipped ..... 4-1**

**LPG Equipped ..... 4-2**

- ▶ For Standard LPG Tank ..... 4-3
- ▶ For Optional LPG Tank ..... 4-4

**5. OPERATION ..... 5-1**

**New Lift Truck Break-in ..... 5-1**

**Before Starting Engine ..... 5-1**

- ▶ Starting Engine ..... 5-2
- ▶ Gasoline / LPG Dual Fuel Type ..... 5-3
- ▶ Instruction for Changeover of Fuel Between LPG and Gasoline ..... 5-3
- ▶ FC Model ..... 5-3

**Starting Engine..... 5-4**

## SAFETY RULES FOR LIFT TRUCK OPERATORS

### ► No Riders Warning Decal

#### ⚠ WARNING

To avoid serious injury, DO NOT carry passengers. This lift truck is designed for only one operator and no riders.

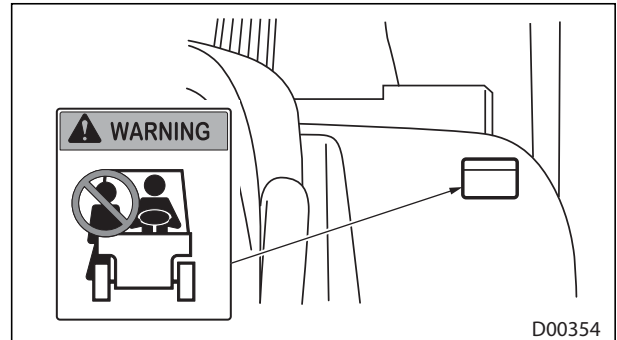

### ► Survive in a Tipover Decal

#### ⚠ DANGER

TIPOVER CAN OCCUR IF TRUCK IS IMPROPERLY OPERATED.  
INJURY OR DEATH COULD RESULT.

#### ⚠ WARNING

##### FOR SAFETY NOTICE FOLLOWING WARNINGS

- (1) Lateral tipover can occur when unloaded if the combination of speed and sharpness of turn produces an overturning moment which exceeds the stability of the truck.
- (2) Lateral tipover can occur if overloaded or loaded within capacity and the load is elevated and if turning and/or braking when traveling rearward or if turning and/or accelerating when traveling forward produces an overturning moment which exceeds the stability of the truck.
  - Rearward tilt and/or off-center positioning of the load and/or uneven ground conditions will further aggravate the above conditions.
- (3) Longitudinal tipover can occur if overloaded or when loaded within capacity of the load is elevated if forward tilt, braking in forward travel, or commencing rearward travel produces an overturning moment which exceeds the stability of the truck.
- (4) Serious injury or death can occur to the operator if he/she is trapped between the truck and the ground.

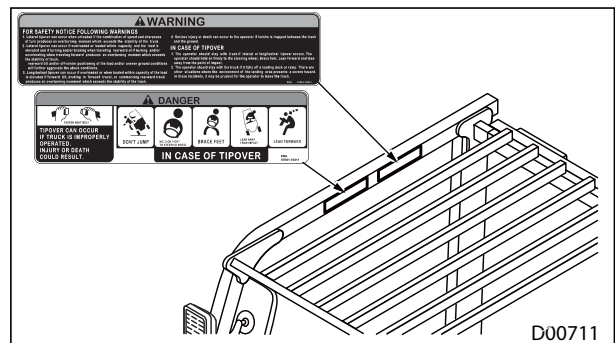

##### IN CASE OF TIPOVER

- (1) The operator should stay with truck if lateral or longitudinal tipover occurs. The operator should hold on firmly to the steering wheel, brace feet, lean forward and lean away from the point of impact.
- (2) The operator should stay with the truck if it falls off a loading dock or ramp. There are other situations where the environment of landing area presents a severe hazard. In those incidents, it may be prudent for the operator to leave the truck.

**⚠ WARNING**

**Face the lift truck when getting on and off!**

Maintain a three point contact (one foot and two hands) with the foot step, the assist grip, and the seat backrest.

- DO NOT get on or off the moving lift truck.
- DO NOT jump on or off the lift truck.
- DO NOT use the operating control levers or steering wheel as assist grips when entering or leaving the operator compartment.
- DO NOT get on or off the right side of the lift truck.

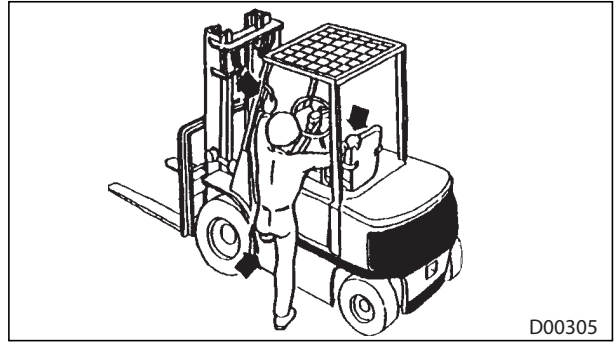

**⚠ WARNING**

**Adjust the operator seat before operating the lift truck!**

DO NOT adjust the operator seat while the lift truck is in motion.



**⚠ WARNING**

**Always check overhead clearance!**

Serious accidents and damages could be caused by the mast and overhead guard hitting pipes, beams or other overhead obstructions. Watch out for power lines.

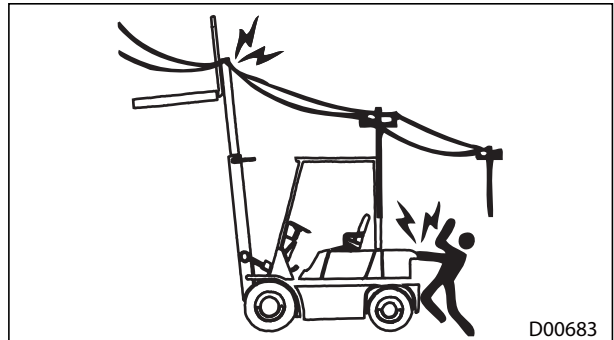

**⚠ WARNING**

**Use lights in dark, dim areas!**

Even with lights ON, DO NOT assume people see you and will move out of your way.

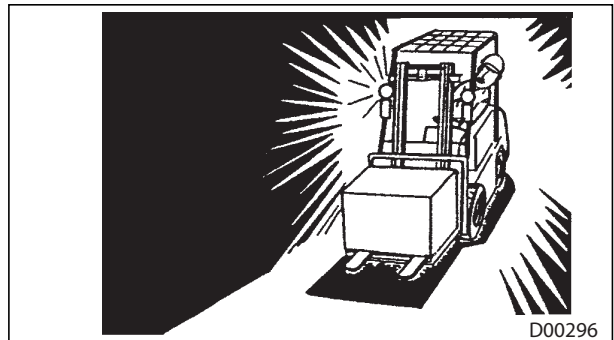

**⚠ WARNING**

**DO NOT speed when approaching loads!**

Approaching loads at high speed is dangerous. This could also damage the load(s).  
Approach the load carefully at slow speeds.

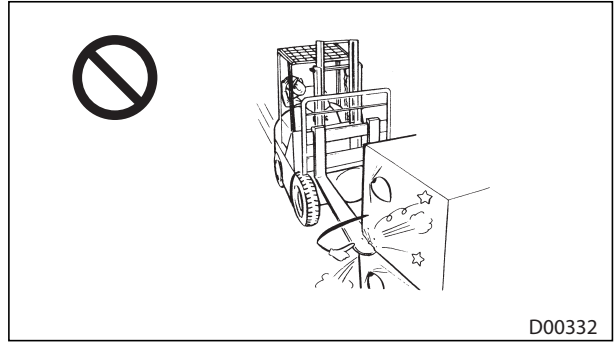

**⚠ WARNING**

**Ensure the load is not too high!**

DO NOT pick up unsecured loads that extend above the load backrest extension height.

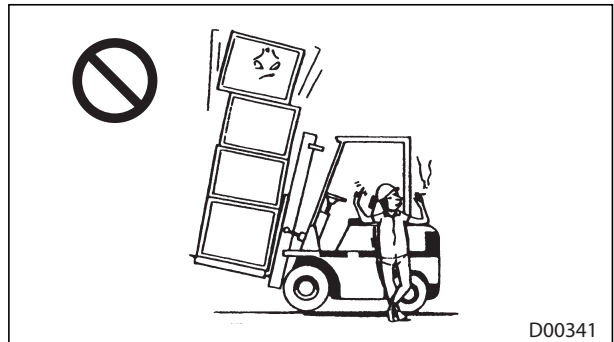

**⚠ WARNING**

**DO NOT move when someone's next to the lift truck!**

If someone is standing next to the lift truck, DO NOT proceed until they are a safe distance away. DO NOT assume that people are aware of you and will move out of your way.

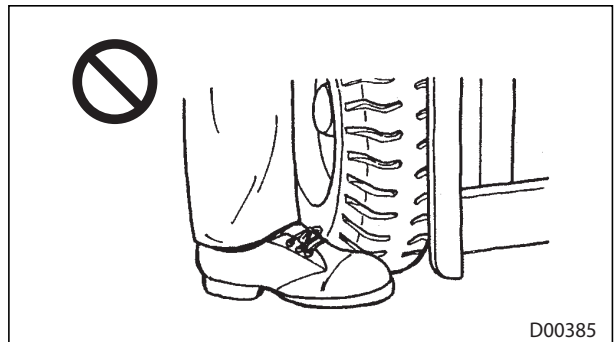

**⚠ WARNING**

**Handle only stable and safely arranged loads!**

If a load is unstable, it could easily shift and fall on someone.

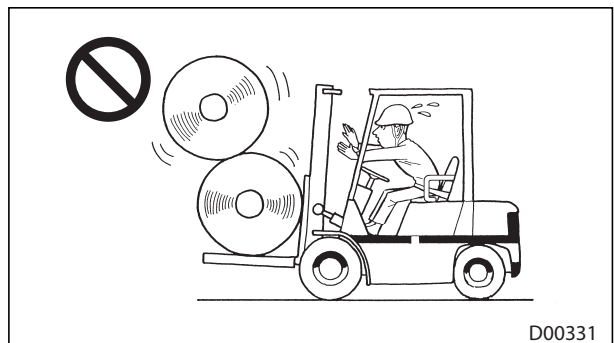

**► MC Model**

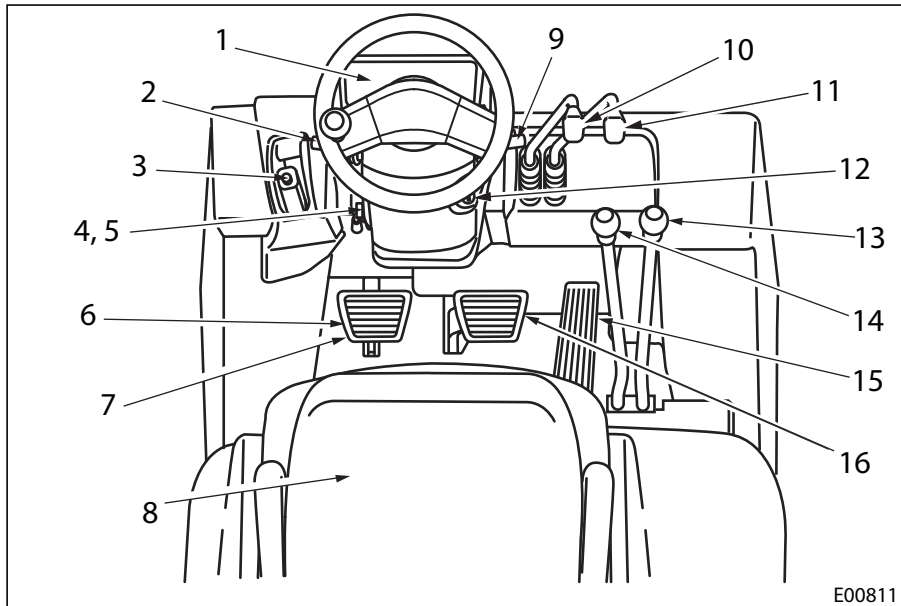

1. Meter Panel
2. Direction Lever (Powershift model)
3. Parking Brake Lever
4. Steering Column Tilt Lever
5. Steering Column Release Lever
6. Inching Pedal (Powershift model)
7. Clutch Pedal (Manual model)
8. Operator Seat
9. Turn Signal / Light Switch
10. Lift Lever
11. Tilt Lever
12. Key Switch
13. Direction Lever (Manual model)
14. Gearshift Lever (Manual model)
15. Accelerator Pedal
16. Brake Pedal

**► FC Model**

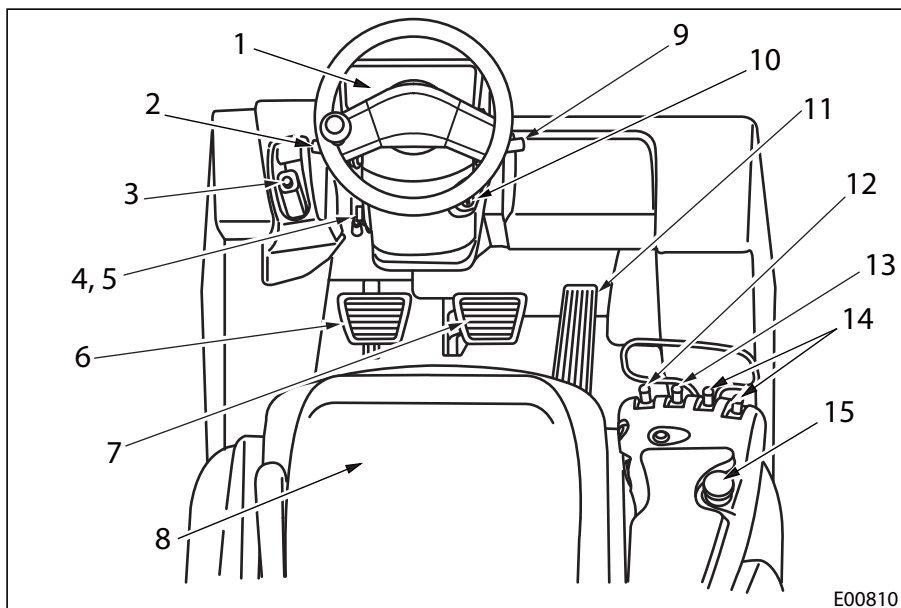

1. Meter Panel
2. Direction Switch
3. Parking Brake Lever
4. Steering Column Tilt Lever
5. Steering Column Release Lever
6. Inching Pedal
7. Brake Pedal
8. Operator Seat
9. Turn Signal / Light Switch
10. Key switch
11. Accelerator Pedal
12. Lift Switch
13. Tilt Switch
14. Attachment Switch
15. Emergency mast stop button

**Speedometer display**

Speedometer reads the current speed.

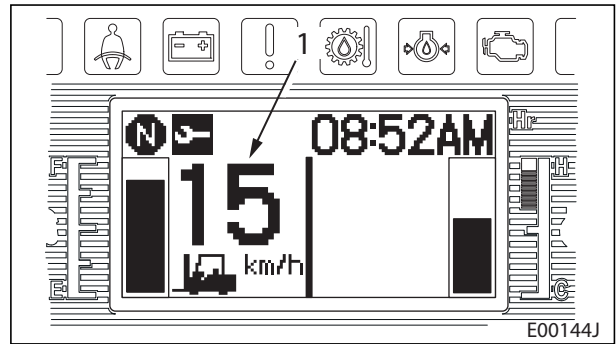

1. Speedometer display

Actual speed	Display
0.1 to 1.0 km/h (0.06 to 0.6 mph)	1 km/h (0.6 mph)
1.1 to 2.0 km/h (0.6 to 1.2 mph)	2 km/h (1.2 mph)
⋮	⋮
⋮	⋮
⋮	⋮
24.1 to 25.0 km/h (14.9 to 15.5 mph)	25 km/h (15.5 mph)

**Fuel gauge display**

When the key switch is turned to the ON position, the fuel gauge will indicate the remaining fuel amount in the tank. If the ground is not level, the correct fuel amount will not be shown.

When the fuel gauge shows E (Empty), the low fuel level warning icon will be displayed on the LCD screen.

- LPG model does not show the fuel gauge.

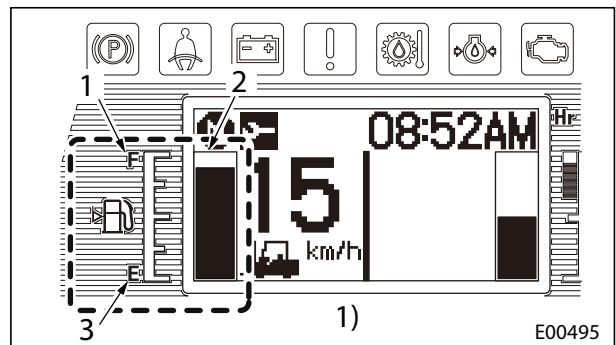

1) With fuel gauge  
 1. Full  
 2. Fuel gauge  
 3. Empty

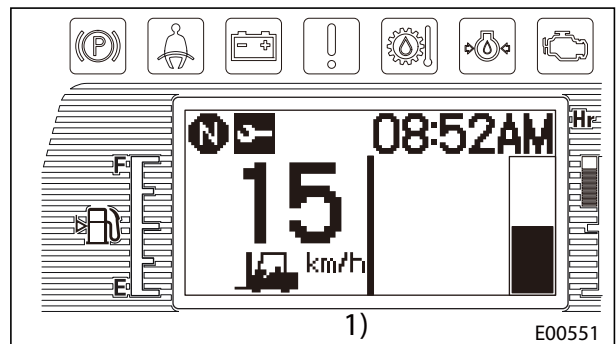

1) Without fuel gauge

**Amount of fuel remaining when fuel gauge shows E (Empty)**

Model	Remaining amount
1.0 to 2.0C	Less than 5 L
2.0 to 3.5A	Less than 7.5 L



► **Tilt Switch**

Tilt speed is controlled by the speed of the engine (the position of the accelerator pedal) and the position of the tilt switch. The switch will return to the NEUTRAL position when released.

To deactivate the mast interlock system, the operator sits on the operator seat while the key switch is in the ON position with the engine running, and then operate the tilt switch.

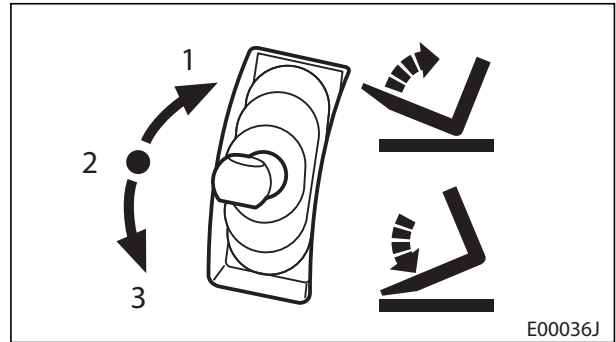

1. Backward  
2. Neutral  
3. Forward

► **Attachment Switch A/B (Optional)**

To deactivate the mast interlock system, the operator sits on the operator seat while the key switch is in the ON position with engine running, and then operate the attachment switch.

**Attachment switch A (optional)**

This switch is for operating the third attachment.

**Attachment switch B (optional)**

This switch is for operating the fourth attachment.

► **Selector Switch Between Forth and Fifth Attachment**

For operation of the fifth attachment, operate the attachment switch B while pressing this switch.

► **Lowering Speed Selector Switch (Optional)**

Do not touch the lift/tilt or attachment switch when turning this switch ON or OFF.

**Slow**

This position allows you to lower the forks at 70% of the normal or rated speed. Use this switch until you feel sure of what is going to happen when you move the lift control, or when you handle fragile loads.

**Normal**

This position allows you to lower the forks at the normal speed.

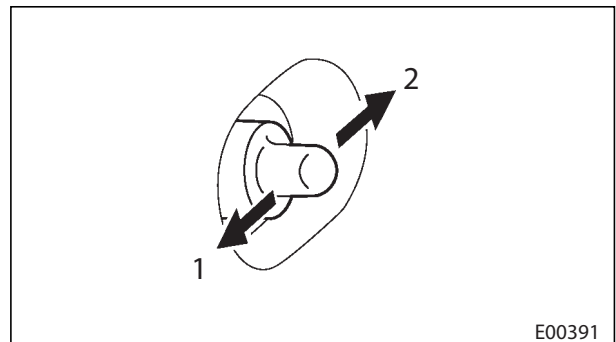

1. Slow  
2. Normal

### ◆ Replacing Forks

Remove a fork from the lift bracket to replace it or to access other parts of the lift truck for maintenance.

#### ⚠ WARNING

DO NOT try to install or remove a fork without a lifting device. Each fork could weigh in excess of 45 kg (100 lb.).

#### How to remove forks

- (1) Slide the forks, one at a time, to the installation/removal recess on the bottom carriage bar.
- (2) Tilt the lift bracket forward, then lower it until the fork hook disengages the forks from the lift bracket.
- (3) Use a lifting device to move the forks away from the lift truck.

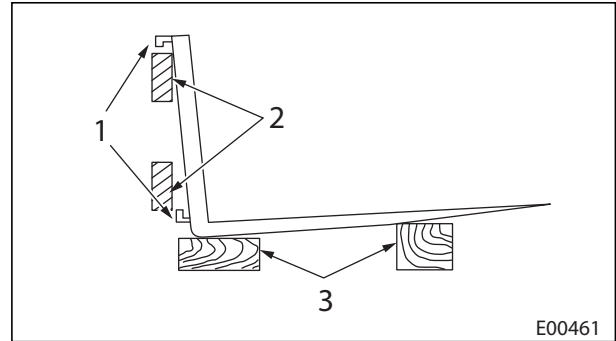

1. Fork Hook  
2. Carriage Bars  
3. Wood Blocks

#### How to install forks

- (1) Position the forks side-by-side on the floor in a location where they can be approached from the rear by the lift truck.
- (2) Slowly drive the lift truck, with the lift bracket fully lowered and fully tilted forward, to a point just to the rear of the forks.
- (3) Carefully slide the forks, one at a time, onto the lift bracket so the top hook of the fork is placed above the top carriage bar.
- (4) Raise the lift bracket to engage the top hooks allowing the bottom hooks to pass through the installation/removal recess.
- (5) Carefully slide each fork on the carriage bar so both the upper and lower hooks engage the lift bracket.
- (6) Lock the forks in place by engaging the fork lock pins.

### ◆ Drawbar Pin

Use the drawbar pin for the following situations:

- Pulling the lift truck out of a drop-off or ditch.
- Loading and unloading the lift truck on a transport truck.
- When loading the lift truck on a hauling track by using the drawbar pin, start the engine, and release the parking brake lever.

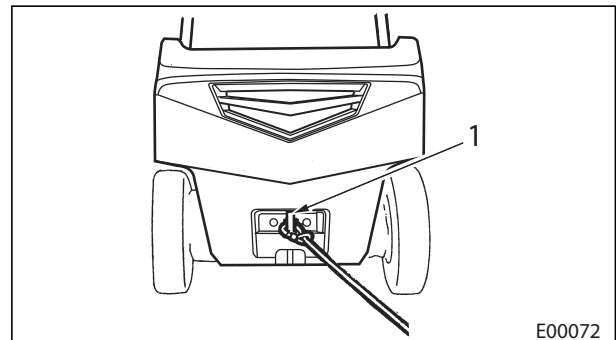

1. Drawbar pin

#### ⚠ WARNING

DO NOT use the drawbar pin for towing loads.

## REFUELING

### ◆ Gasoline and Diesel Engine Equipped

#### ⚠ WARNING

- BE SURE to use the proper fuels specified in the SERVICE DATA. If not, the engine could fail.
- Lift trucks must be refueled only at designated safe locations. Safe outdoor locations are preferable to those indoors.
- Stop the engine and get off the lift truck during refueling.

#### ⚠ WARNING

- Explosive fumes could be present during refueling.
- DO NOT smoke in refueling areas.

#### ⚠ WARNING

##### Fire caused by static electricity!

- In dry seasons, there is a lot of static electricity. The fuel could catch fire due to the static electrical spark.
- When refueling, touch grounded metals with bare hand to discharge the static electricity before opening the filler cap.

#### ⚠ CAUTION

- Do not allow the lift truck to become low on fuel or completely run out of fuel. Sediment or other impurities in the fuel tank could be drawn into the fuel system. This could result in difficult starting or damage to components.
- Fill the fuel tank at the end of each day of operation to drive out moisture laden air and to prevent condensation.
- Do not fill the tank to the top. Fuel expands when it gets warm and may overflow.

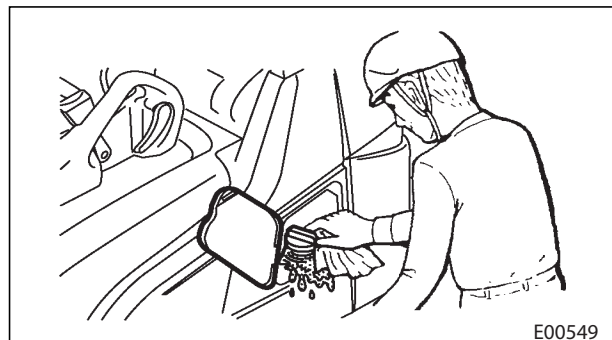

##### Refueling steps

- (1) Park the lift truck only at a location designated safe.
- (2) Lower the forks until the fork tips touch the floor or ground.
- (3) Apply the parking brake.
- (4) Place the direction lever in the NEUTRAL position.
- (5) Stop the engine.
- (6) Block the wheels.
- (7) Open the filler cap.
- (8) Fill the fuel tank slowly.
- (9) Close and tighten the filler cap.
- (10) If spillage occurs, wipe off excess fuel.

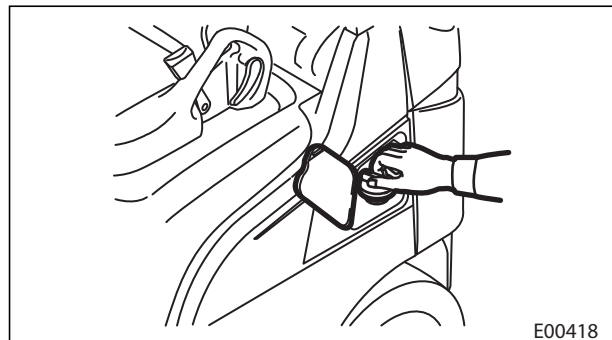

Note: Drain water and sediment from the fuel tank as needed. Also, drain water and sediment from the main fuel storage tank before it is filled and as a weekly routine. This will help prevent water or sediment being pumped from the storage tank into the lift truck fuel tank.

## ◆ Engine Won't Start

Contact your authorized Cat lift truck dealer if the engine still does not start after you have attempted the following.

### Does the starter crank the engine?

#### YES

Check the fuel gauge to see if there is fuel in the tank. If not, refuel it.

#### ► When Engine Is "Flooded"

#### Gasoline model

(1) Press the accelerator pedal all the way down and hold in this position.

#### NO

The battery is dead if the head lamps don't turn ON or dimly light.

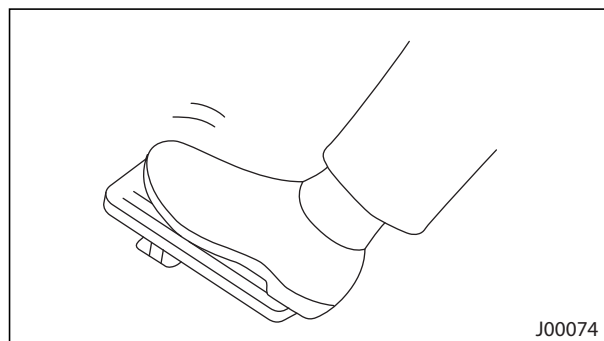

(2) Turn the key switch to the START position.

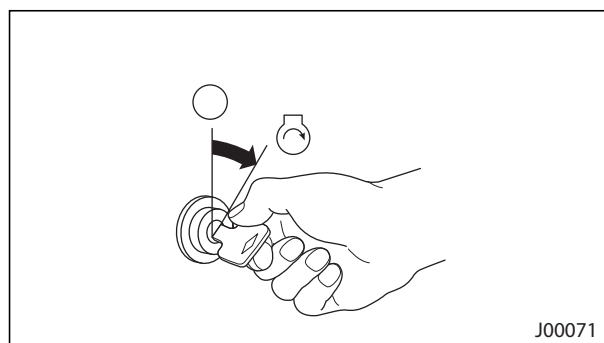

Note: The head lamps should be turned OFF for easier starting.

## ⚠ CAUTION

DO NOT start the engine by pushing or towing the lift truck. This may cause serious injury to the operator and damage to the lift truck.

## ◆ Parking Lift Truck (After Stopping)

### ⚠ WARNING

#### Park safely

- Select a hard level surface.
- BE SURE to park in the designated parking area.

(1) Apply the parking brake lever.

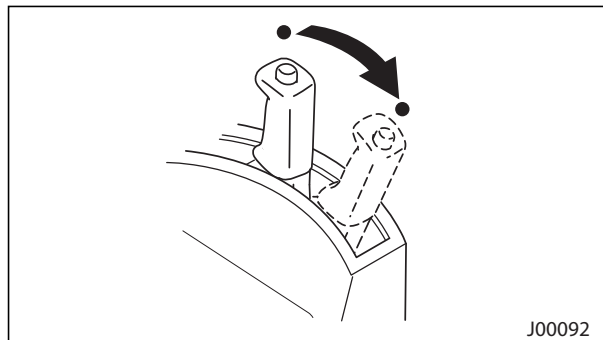

(2) Place the direction lever in the NEUTRAL position.

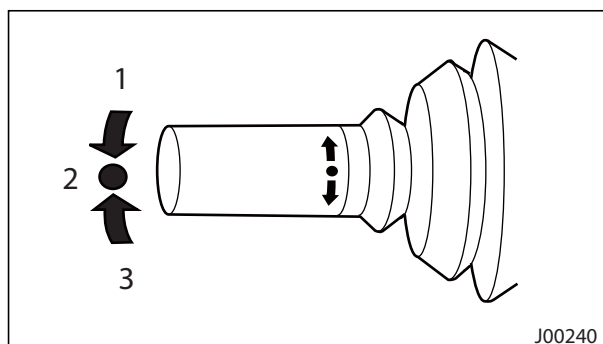

1. Forward (F)

2. Neutral (N)

3. Reverse (R)

(3) Slightly, tilt the mast forward and lower the forks to the floor or ground until the fork tips touch the floor or ground.

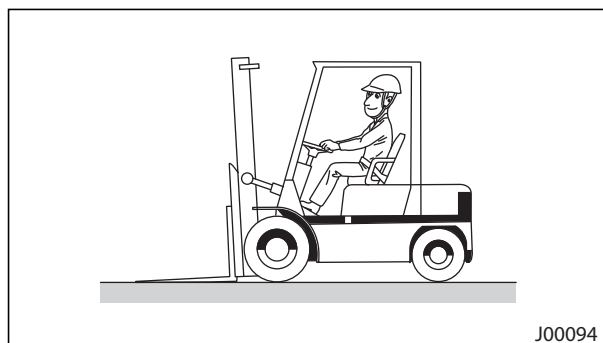

(4) Turn the key back to the OFF position to stop the engine. When leaving the lift truck, be sure to remove the key.

(5) Block the wheels securely.

(6) Return the key to a key rack if specified.

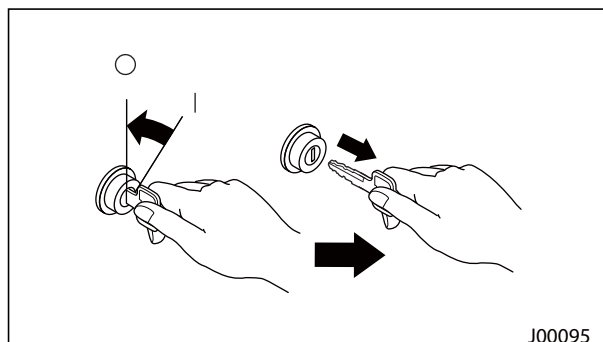

## ◆ Traveling with the Load

- (1) Place the direction lever in the NEUTRAL position.
- (2) Make sure the load is centered on the forks.

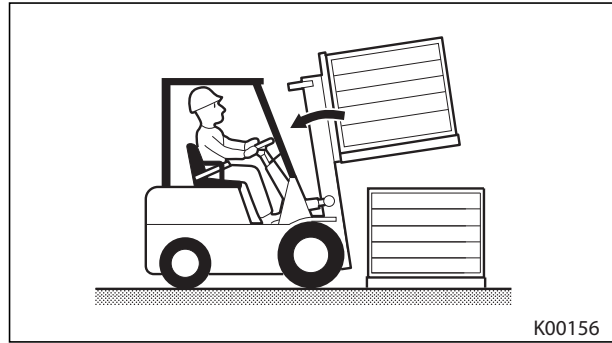

- (3) Look behind you.
- (4) Place the direction lever into the REVERSE position.

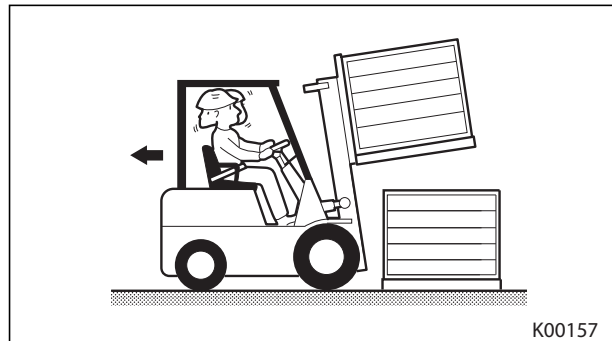

- (5) Slowly move the lift truck 20 to 30 cm (8 to 12 in.) away from the stack, and then stop the lift truck.
- (6) Place the direction lever in the NEUTRAL position.
- (7) Lower the forks to a position 15 to 20 cm (6 to 8 in.) from the ground.

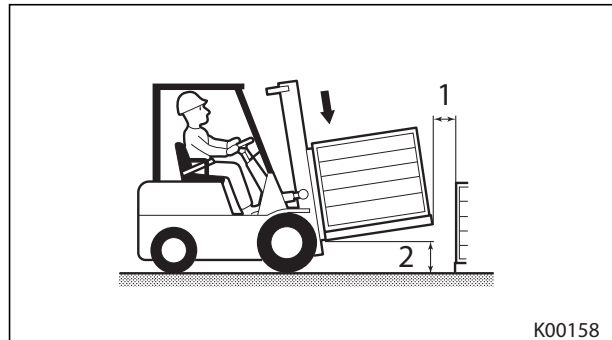

1. 20 to 30 cm (8 to 12 in.)

2. 15 to 20 cm (6 to 8 in.)

- (8) Tilt the mast fully backward to cradle the load.

## ⚠ WARNING

Slack lift chains means there is a rail or lift bracket hang up. Raise the mast before you move.

When stacking:

- Watch your lift chains.
- If they go slack, stop lowering. Then raise the load and lower it again.

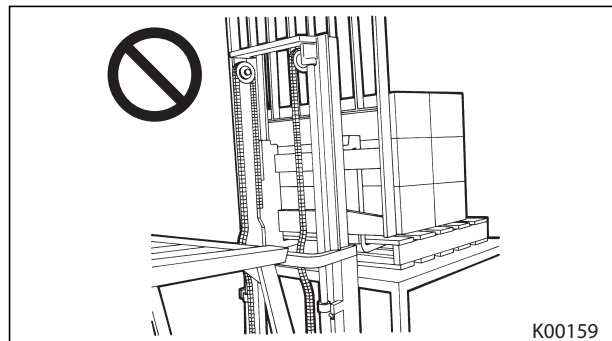

## SPECIAL SITUATIONS

### ► Engine Coolant

- Antifreeze used in the engine cooling system of a new lift truck shipped from the manufacturer provides sufficient freeze protection to  $-30^{\circ}\text{C}$  ( $-22^{\circ}\text{F}$ ).
- If ambient temperatures are below  $-30^{\circ}\text{C}$  ( $-22^{\circ}\text{F}$ ), add antifreeze.

Note: For type and concentration of antifreeze, contact your authorized Cat lift truck dealer.

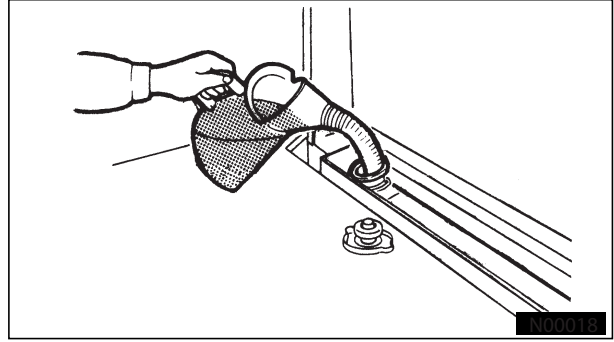

### ◆ Care in Hot Weather

#### ► Fuel Oils and Lubrication Oils

Use fuel oil, engine oil and gear oil to fit the ambient temperatures.

Note: For selection of fuel oil, engine oil and gear oil, contact your authorized Cat lift truck dealer.

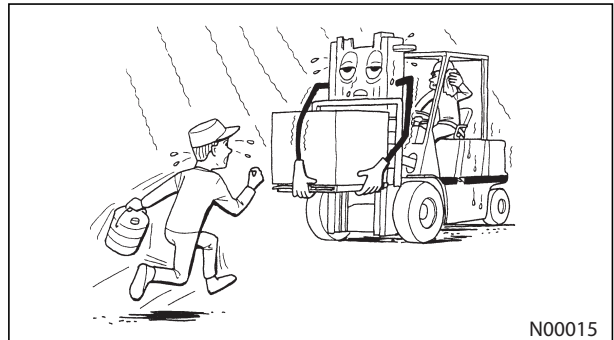

#### ► Battery

In hot and/or dry weather, check the battery cells for proper electrolyte level more often than in cold weather. Add distilled water whenever the level is low.

#### ► Engine Coolant

### ⚠ WARNING

Be careful NOT to have scalding hot coolant or steam blow out of the reserve tank. Remove the radiator cap only after engine cools.

Note: Coolant evaporates rapidly and the engine is likely to get overheated when the lift truck is operated continuously or on a grade. During such an operation, observe the engine coolant temperature gauge for symptoms of overheating.

### ⚠ CAUTION

If the engine coolant temperature gauge shows the red zone, the engine may be overheated.

Note: If the engine coolant temperature gauge shows the red zone, see 10-8 "If the Engine Coolant Temperature Gauge Shows Red Zone".

## ◆ If Torque Converter Oil Temperature Warning Icon Glows (Powershift Model)

- (1) Stop the lift truck in a non-traffic area.
- (2) Set the parking brake.
- (3) Place the direction lever in the NEUTRAL position.
- (4) Run the engine at low idle for a while.
- (5) After the warning icon has gone out, operate the lift truck again.

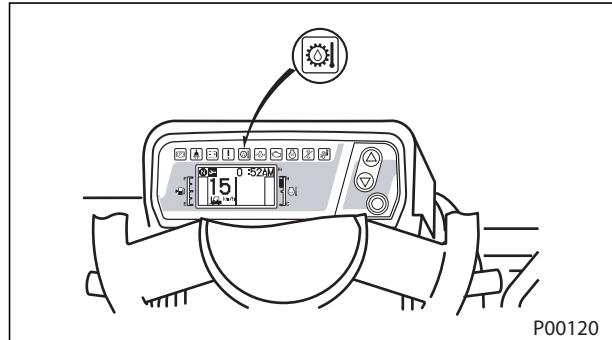

P00120

### ⚠ CAUTION

If the warning icon does not go out, or if it constantly glows, contact your authorized Cat lift truck dealer.

## ◆ Trouble with the LPG Equipment

### ⚠ WARNING

- If you smell gas or notice something wrong with LPG equipment during operation, immediately stop the lift truck in a safe area, turn the key switch to the OFF position, close the fuel valve of the LPG tank, and try to find the cause. (It is recommended that the fuel lines and fittings be checked with a soap solution after filling the tank or when looking for leaks.)
- If the internal pressure of the LPG tank rises too high and causes the relief valve to open to let out the excess pressure, sprinkle water over the tank. At the same time, extinguish any fire or flame source (such as a pilot icon) and eliminate the possibility of creating sparks near the lift truck. Ventilate the work place.
- When gas leakage is evident, close the fuel valve as soon as possible. Extinguish the fire or flame sources nearby to prevent spark conditions.
- There is a possibility of fire after a collision or when the lift truck turns over. If this happens, close the LPG fuel valve of the LPG tank as soon as possible.
- Use a dry chemical (powder) or carbon dioxide type extinguisher. DO NOT use water. When possible, however, have large quantities of water poured over the LPG tank to cool it down while the fire is being extinguished.

## ◆ Inspection Precautions

### ⚠ WARNING

If the lift truck requires any repair, attach a "DO NOT OPERATE" or similar warning tag to the steering wheel or other controls, remove the key from the key switch, and contact your authorized Cat lift truck dealer.

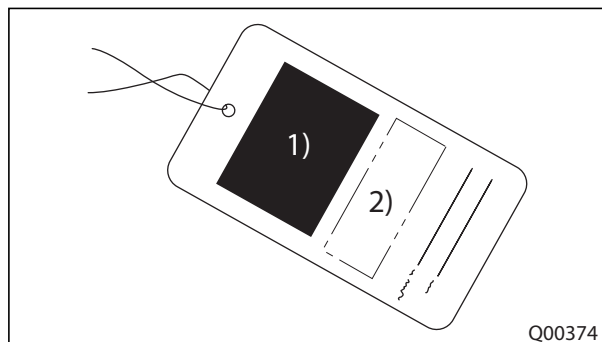

1) DANGER

2) DO NOT OPERATE

### ⚠ WARNING

If it is necessary to make an inspection while the engine is running, ALWAYS USE TWO WORKERS---one, the operator, at the controls and the other checking within visual contact of the operator.

### ⚠ CAUTION

A daily (Pre-Start) inspection is the key to safety. At the beginning of each shift, check your lift truck to make sure it is in a safe operating condition. Always inspect your lift truck under the following conditions.

- Lift truck on level ground
- Mast in vertical position
- Fork tips on ground
- Engine stopped
- Control levers in neutral.
- Wheels blocked.

### ⚠ CAUTION

- Avoid mixing lubricants. In some cases, different brands of lubricants are not compatible with each other and deteriorate when mixes. It is best to stick with the same brand at successive service intervals.
- Before refilling, clean filler holes. After filling, clean up spills.

### ⚠ CAUTION

Contact your authorized Cat lift truck dealer for the proper disposal of wastes accumulated after replacement of tires, batteries, oils and fluids.

## MAINTENANCE

### ► Wheel Nuts

#### Check--Tighten When Required

Wheel nuts should be visually inspected everyday. Any loose nuts should be tightened and any missing or damaged nuts should be changed.

- Are the wheel nuts tightened properly?

Use a torque wrench.

#### How to retighten

- (1) Always stand behind the tread of the tire, NOT in front of the rim.
- (2) Tighten the nuts evenly and in a diagonal sequence to the specified torque.

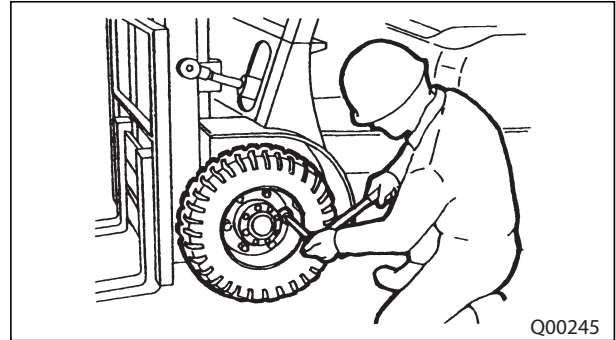

#### Tightening torques for wheel nuts

Models	Side	Torque
1 to 2 ton compact	Front	157 N·m (16 kgf·m) [116 lbf·ft]
	Rear	
2 to 3 ton	Front	378 N·m (38.5 kgf·m) [279 lbf·ft]
	Rear: 2P	
	157 N·m (16 kgf·m) [116 lbf·ft]	
	Rear: 4P	
		233 N·m (23.8 kgf·m) [172 lbf·ft]
3.5 ton	Front	378 N·m (38.5 kgf·m) [279 lbf·ft]
	Rear	233 N·m (23.8 kgf·m) [172 lbf·ft]

## How to add engine oil

### ⚠ WARNING

When adding engine oil:

- Perform the work on level ground.
- Clean the filler hole to prevent dirt from dropping into the engine.
- DO NOT overfill.
- Clean up spillage.

(1) Remove the oil filler cap.

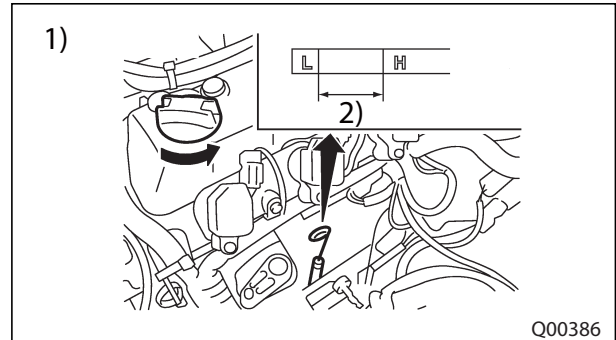

1) Gasoline model

2) Correct level range

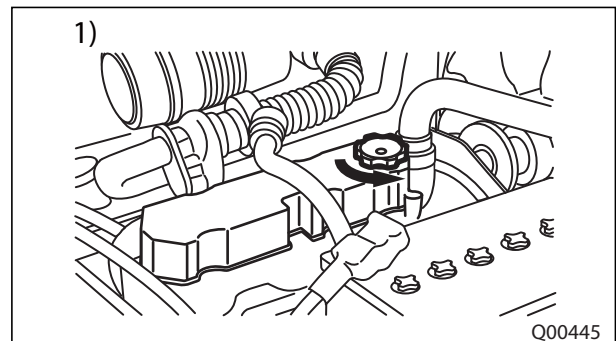

1) Diesel model

- (2) Add engine oil as required.  
For engine oil, see 12-4 "Recommended Fuels and Oils".
- (3) After adding oil, make sure the level is in the correct range on the dip stick.
- (4) Close and tighten the filler cap.

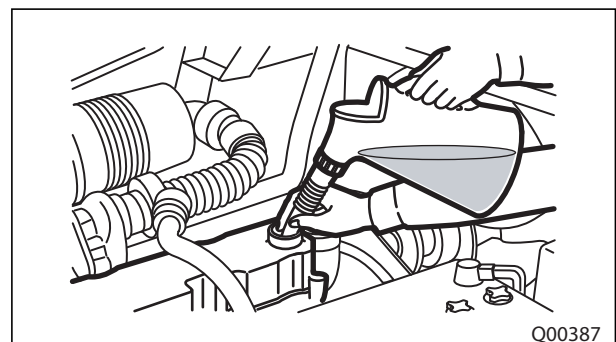

### ► Engine Cooling Fan

#### Check

- Check for damage and rotation.

## MAINTENANCE

### ► Brake Pedal

- Do the brakes apply and stop the truck properly without pulling, dragging, chattering, squealing?



- Check if the lift truck stops when pulling the parking brake lever on a grade.

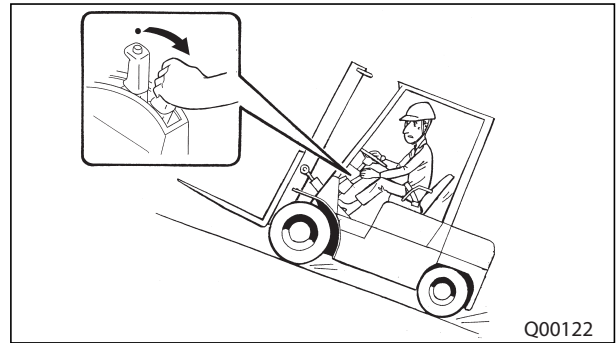

### ► Steering Wheel

Check the condition of steering wheel.

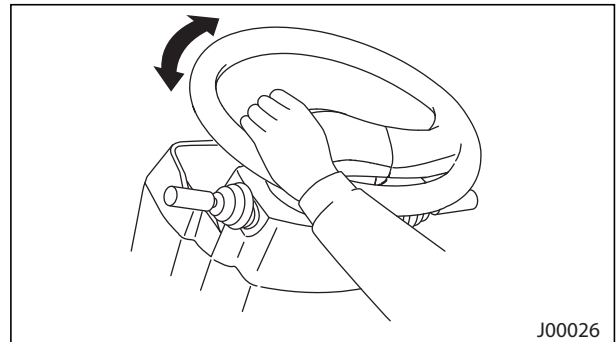

## MAINTENANCE

### ► Mast Strip Sliding Surfaces

#### Lubricate

Inspect the mast strip surfaces for wear and cracks.

- Does the mast and rollers move smoothly? If not, lubricate on each side of the inner mast.

For lubrication of mast strip sliding surfaces, have it done by your authorized Cat lift truck dealer.

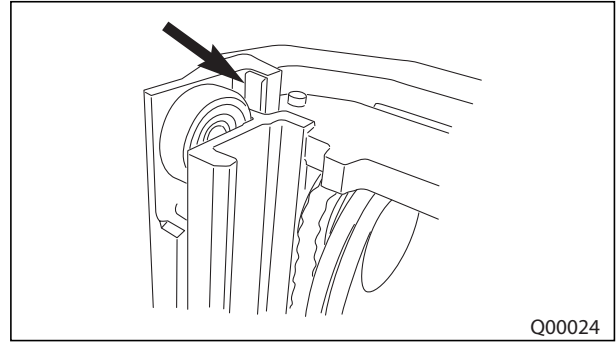

Q00024

### ► Differential

#### Check Oil Level

Park the lift truck on level ground with the forks lowered until the fork tips touch the ground, parking brake applied, direction lever in the NEUTRAL position, engine stopped and the wheels blocked.

- (1) Raise the lift bracket high enough to gain access to the level/fill plug.
- (2) Use blocking under the inner mast to secure the lift bracket in this position.
- (3) Remove the level/fill plug.  
Maintain lubricant level to the bottom of the level/ fill hole.
- (4) Clean and install the level/fill plug.
- (5) Remove the blocking. Lower the lift bracket.

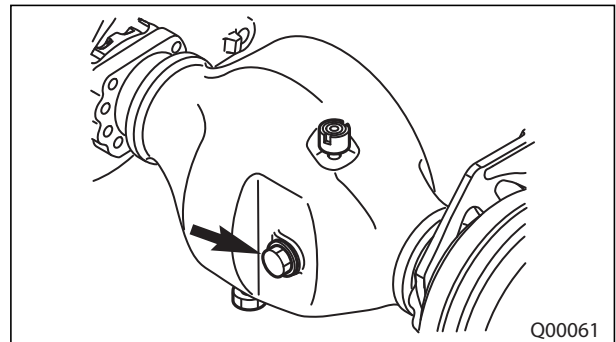

Q00061

#### Adding Oil

See 11-52 "Differential".

#### Adding Oil

- (1) Raise the lift bracket high enough to gain access to the level/fill plug.
- (2) Use blocking under inner mast to secure the lift bracket in this position.
- (3) Remove the drain plug and the level/fill plug.
- (4) Allow the oil to drain. Clean and install the drain plug.
- (5) Fill with oil to the bottom of the level/fill hole.
- (6) Put the level/fill plug back in place.
- (7) Remove the blocking. Lower the lift bracket.

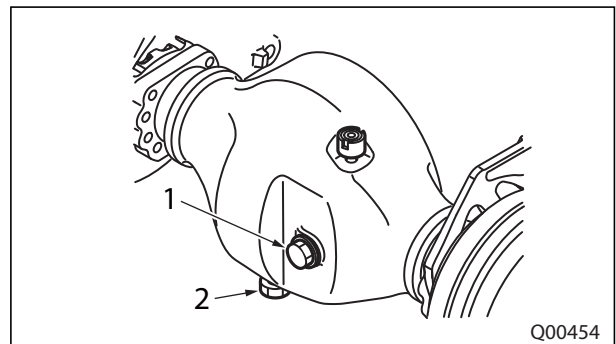

Q00454

1. Level/fill plug

2. Drain plug

## ► Powershift Transmission

### Replace Oil and Wash Strainer

#### ⚠ WARNING

Hot oil and components could cause injury. Do not allow hot oil or components to contact your skin.

Note: Park the lift truck on level ground with the forks lowered until the fork tips touch the ground, parking brake applied, direction lever in the NEUTRAL position, engine stopped and the wheels blocked.

- (1) Remove the drain plug. Allow the oil to drain. Remove the cover, the O-ring seal and the strainer.
- (2) Wash the strainer and the plug in clean, nonflammable solvent. Dry the strainer and the plug. Wipe off the O-ring seal, check and replace if necessary. Install the strainer, the O-ring seal, and the cover. Put the drain plug back in place.

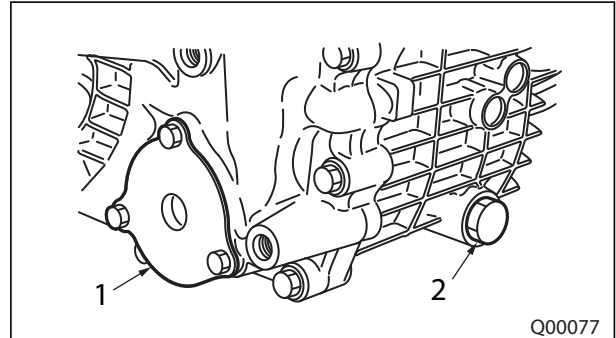

1. Cover

2. Drain plug

- (3) Remove the floor plate.
- (4) Remove the dip stick. Fill the transmission with oil. See 12-11 "Refill Capacities". Install the dip stick.
- (5) Start the engine.
- (6) Run the engine at low idle.
- (7) Stop the engine.
- (8) Remove the dip stick. Check the oil level.
- (9) Add oil, if needed, to reach the correct level range on the dip stick.
- (10) Check for oil leaks at the strainer and drain plug.
- (11) Install the floor plate.

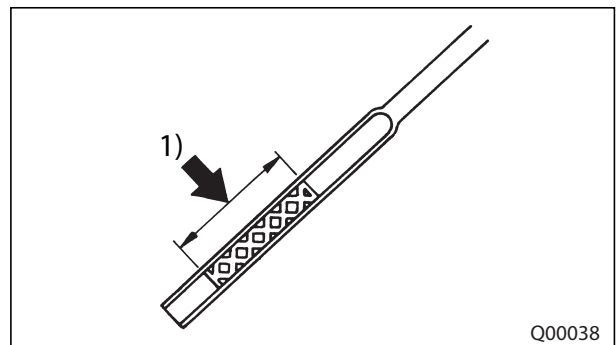

1) Correct level range

## ► Differential

### Replace Oil

Note: Park the lift truck on level ground with the forks lowered until the fork tips touch the ground, parking brake applied, direction lever in the NEUTRAL position, lubricant warm, engine stopped the wheels blocked.

- (1) Raise the lift bracket high enough to gain access to the level/fill plug.
- (2) Use blocking under inner mast to secure the lift bracket in this position.
- (3) Remove the drain plug and the level/fill plug.
- (4) Allow the oil to drain. Clean and install the drain plug.
- (5) Fill with oil to the bottom of the level/fill hole.
- (6) Put the level/fill plug back in place.
- (7) Remove the blocking. Lower the lift bracket.

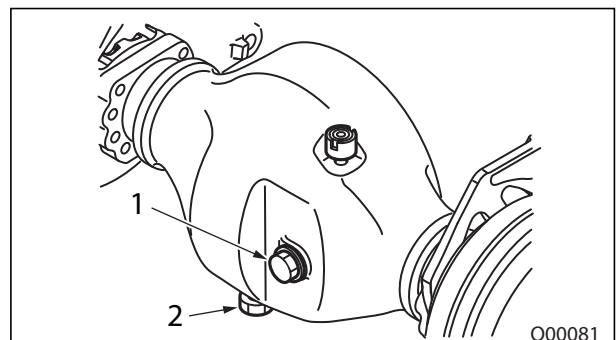

1. Level/fill plug

2. Drain plug

**► Antifreeze Solution**

The manufacturer recommends that the coolant mix contain 50% commercially available automotive antifreeze, or equivalent, and acceptable water to maintain an adequate water pump cavitation temperature for efficient water pump performance.

Note:

- Do not add pure (100%) antifreeze to the cooling system. Add antifreeze mixed with distilled water using the same freeze protection ratio that is in your cooling system.
- Premix the coolant solution to provide protection to the lowest expected outside (ambient) temperature. Pure undiluted antifreeze will freeze at -23°C (-10°F).
- Use a greater concentration (above 50%) of commercially available automotive antifreeze only as needed for anticipated outside (ambient) temperatures.
- Do not exceed the coolant-to-water mix ratio recommendations provided with the commercially available automotive antifreezes.
- Most commercial antifreezes are formulated for gasoline engine applications and will, therefore, have high silicate content.

## ◆ Instructions for Ordering Parts

When ordering parts, or when asking your authorized Cat lift truck dealer to have your lift truck repaired, be sure to provide the following items:

- Lift truck model
- Lift truck serial number
- Engine serial number

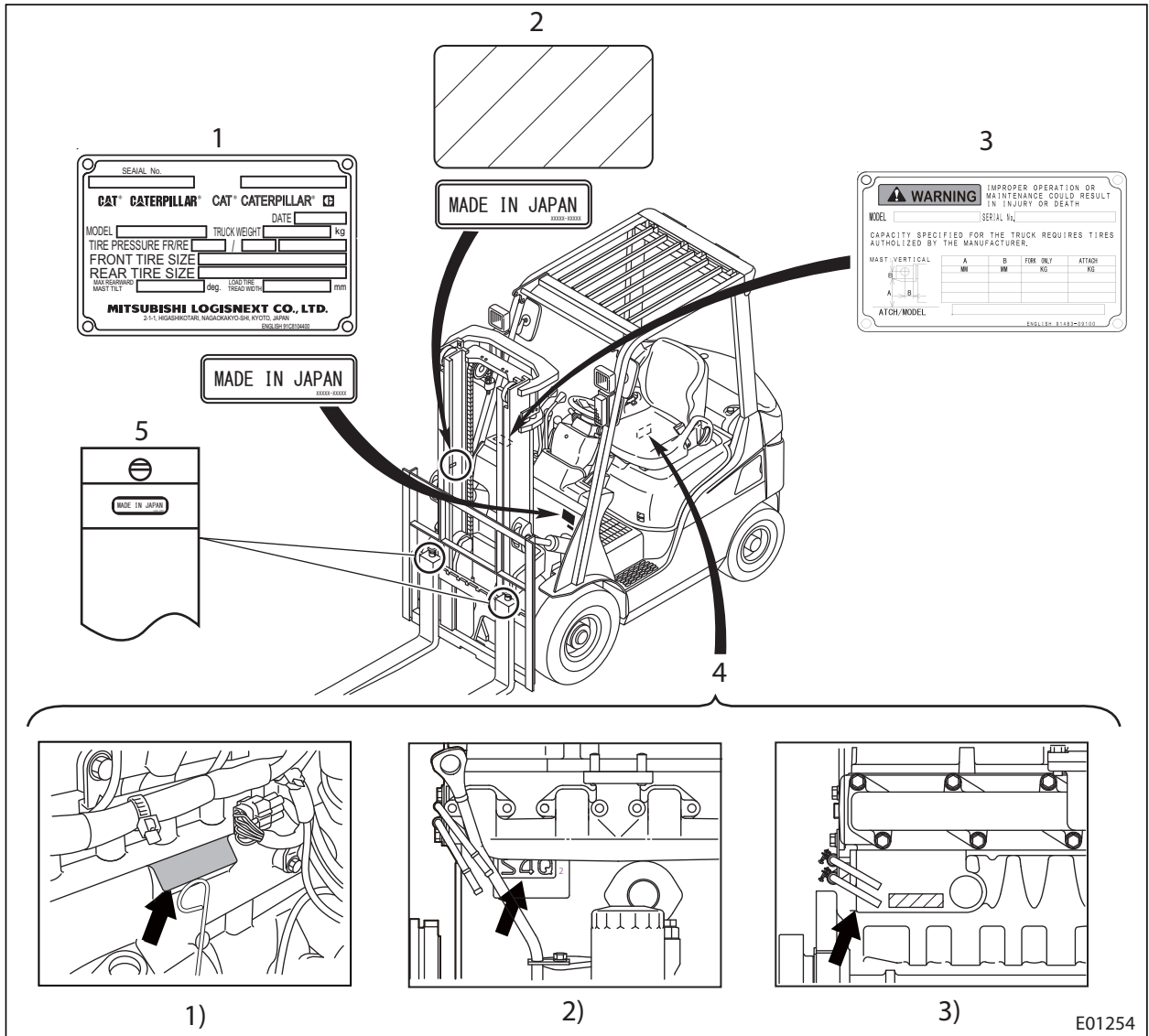

- |   |  |
|---|--|
| <ol style="list-style-type: none"> <li>1. Manufacturer Name Plate with MADE IN JAPAN decal</li> <li>2. Mast Serial Number Plate with MADE IN JAPAN decal</li> <li>3. Capacity Plate</li> <li>4. Engine Serial Number</li> <li>5. Fork with MADE IN JAPAN decal</li> </ol> | <ol style="list-style-type: none"> <li>1) Gasoline model (Left side of engine)</li> <li>2) Diesel 1 ton model (Left side of engine)</li> <li>3) Diesel 2 to 3 ton model (Left side of engine)</li> </ol> |
|---|--|

E01254

1.12	Preparation for Removing Pipes and Radiator (Power Shift T/M Truck)	5-6
1.13	Removal Sequence of Pipes and Radiator (Manual T/M Truck)	5-6
1.14	Suggestions for Installing Pipes and Radiator (Powershift T/M Truck)	5-6
1.15	Preparation for Removing Engine and Transmission Assembly	5-7
1.16	Removal Sequence of Engine and Transmission Assembly	5-7
1.17	Suggestions for Removing Engine and Transmission Assembly	5-7
1.18	Suggestions for Installing Engine and Transmission Assembly (Manual T/M truck)	5-8
1.19	Suggestions for Installing Engine and Transmission Assembly (Power Shift T/M Truck)	5-9
2.	Installation of Engine and Transmission Assembly (for Diesel Truck)	5-10
2.1	Removal Sequence of Overhead Guard, Air Cleaner and Others	5-10
2.2	Suggestions for Removing Overhead Guard, Air Cleaner and Others	5-11
2.3	Removal Sequence of Controls (Manual T/M Truck)	5-11
2.4	Removal Sequence of Controls (Power Shift T/M Truck)	5-11
2.5	Preparation for Removing Pipes and Radiator (Manual T/M Truck)	5-12
2.6	Removal Sequence of Pipes and Radiator (Manual T/M Truck)	5-12
2.7	Suggestions for Installing Pipes and Radiator (Manual T/M Truck)	5-12
2.8	Preparation for Removing Pipes and Radiator (Power Shift T/M Truck)	5-13
2.9	Removal Sequence of Pipes and Radiator (Power Shift T/M Truck)	5-13
2.10	Suggestions for Removing Pipes and Radiator (Power Shift T/M Truck)	5-13
2.11	Suggestions for Installing Pipes and Radiator (Power Shift T/M Truck)	5-13
2.12	Preparation for Removing Engine and Transmission Assembly	5-14
2.13	Removal Sequence of Engine and Transmission Assembly	5-14
2.14	Suggestions for Removing Engine and Transmission Assembly	5-14
2.15	Suggestions for Installing Engine and Transmission Assembly	5-14

## **Chapter 6 CLUTCHES**

1.	Structure	6-1
1.1	Advantages and Disadvantages of Clutches by Type of Drive System	6-1
1.2	Main Differences Between Dry-Type and Wet-Type Clutches	6-2
1.3	Structure and Function of Clutch	6-3
2.	Clutch Assembly, Disassembling	6-8
2.1	Disassembly Sequence	6-8
2.2	Suggestions for Disassembly	6-9
3.	Clutch Assembly, Inspection and Repair After Disassembly	6-11
3.1	Clutch Disc Assembly	6-12
4.	Clutch Assembly, Assembling	6-13
4.1	Assembly Sequence	6-13
4.2	Suggestions for Assembly	6-13
5.	Pressure Plate Assembly, Disassembling	6-16
5.1	Disassembly Sequence	6-16
6.	Pressure Assembly, Inspection and Repair After Disassembly	6-17
7.	Pressure Assembly, Assembling	6-18
7.1	Suggestions for Assembly	6-18
8.	Clutch Master Cylinder (Dry Type Clutch), Disassembling	6-20

## Chapter 14 MAST AND FORKS

1.	Simplex Mast .....	14-1
1.1	Mast System .....	14-1
1.2	Structure and Functions (5V15D to 5V35D) .....	14-2
1.3	Mast and Lift Bracket Assembly, Removal Sequence .....	14-4
1.4	Suggestions for Removing of Mast and Lift Bracket Assembly .....	14-4
1.5	Suggestions for Installing of Mast and Lift Bracket Assembly .....	14-6
1.6	Mast and Lift Bracket, Removal Sequence .....	14-7
1.7	Suggestions for Disassembly of Mast and Lift Bracket .....	14-7
1.8	Mast and Lift Bracket, Inspection (All Mast Models) .....	14-8
1.9	Lift Bracket Roller, Assembly Sequence (All Mast Models) .....	14-9
1.10	Lift Bracket Clearance Adjustment (All Mast Models) .....	14-10
1.11	Installing Mast Rollers (All Mast Models) .....	14-12
1.12	Installing Mast Strips (All Mast Models) .....	14-13
1.13	Installing Lift Cylinders .....	14-14
1.14	Connecting Chains .....	14-15
1.15	Installing Hydraulic Lines .....	14-16
1.16	Mast Rollers and Strips, Removal and Installation Without Removing Mast from Truck .....	14-18
1.17	Inspection and Adjustment .....	14-19
1.18	Inspecting Forks (All Mast Models) .....	14-19
1.19	Chain Tension, Inspection and Adjustment (All Mast Models) .....	14-21
1.20	Measuring Chain Elongation (All Mast Models) .....	14-22
1.21	Adjusting Clearance Between Lift Bracket Roller and Inner Mast (All Mast Models) .....	14-23
1.22	Adjusting Mast Roller Clearance (All Mast Models) .....	14-25
1.23	Inspecting and Adjusting Mast Strip Clearance (All Mast Models) .....	14-26
1.24	Adjusting Mast Tilt Angle (All Mast Models) .....	14-27
1.25	Inspecting and Adjusting Right and Left Lift Cylinder Stroke (All Mast Models) .....	14-27
1.26	Troubleshooting .....	14-28
1.27	Service Data .....	14-29
2.	Duplex Mast .....	14-32
2.1	Mast System .....	14-32
2.2	Structure and Functions (5F15C to 5F35CF) .....	14-33
2.3	Mast and Lift Bracket Assembly, Removal Sequence .....	14-35
2.4	Suggestions for Removing of Mast and Lift Bracket Assembly .....	14-35
2.5	Suggestions for Installing Mast and Lift Bracket Assembly .....	14-37
2.6	Mast and Lift Bracket, Disassembly Sequence .....	14-38
2.7	Preparation for Disassembly of Mast and Lift Bracket .....	14-38
2.8	Suggestions for Disassembly of Mast and Lift Bracket .....	14-39
2.9	Mast and Lift Bracket, Inspection (All Mast Models) .....	14-40
2.10	Lift Bracket Roller, Assembly Sequence (All Mast Models) .....	14-41
2.11	Lift Bracket Clearance Adjustment (All Mast Models) .....	14-42
2.12	Installing Mast Rollers (All Mast Models) .....	14-44
2.13	Installing Mast Strips (All Mast Models) .....	14-45
2.14	Installing Second Lift Cylinder .....	14-46
2.15	Installing First Lift Cylinder .....	14-47
2.16	Connecting Chains .....	14-47
2.17	Installing Hydraulic Lines .....	14-48

**CHAPTER 1 GENERAL INFORMATION**

Truck model	Class		2 ton class		3 ton class	
	Gasoline engine truck		GP20N GPE20N GP20ZN GPE20ZN	GP25N GPE25N GP25ZN GPE25ZN	GP30N GPE30N	GP35N GPE35N
	Diesel engine truck		DP20N	DP25N	DP30N	DP35N
Capacity	kg		2000	2500	3000	3500
Load center	mm (in.)		500 (19.7)	500 (19.7)	500 (19.7)	500 (19.7)
Lift speed	Loaded	mm/s (fpm)	GP20N: 520 (102.4) GPE20N: 580 (114.2) GP20ZN: 580 (114.2) GPE20ZN: 640 (126.9)	GP25N: 520 (102.4) GPE25N: 580 (114.2) GP25ZN: 580 (114.2) GPE25ZN: 640 (126.9)	GP30N: 460 (90.6) GPE30N: 510 (100.4)	GP35AN: 390 (76.8) GPE35AN: 430 (84.6)
			DP20N: 630 (124.0)	DP25N: 630 (124.0)	DP30N: 500 (98.4)	DP35AN: 420 (82.7)
	Unloaded	mm/s (fpm)	GP20N: 600 (118.1) GPE20N: 590 (116.1) GP20ZN: 660 (129.9) GPE20ZN: 660 (129.9)	GP25N: 600 (118.1) GPE25N: 590 (116.1) GP25ZN: 660 (129.9) GPE25ZN: 660 (129.9)	GP30N: 530 (104.3) GPE30N: 530 (104.3)	GP35AN: 450 (88.6) GPE35AN: 440 (88.6)
			DP20N: 660 (129.9)	DP25N: 660 (129.9)	DP30N: 530 (104.3)	DP35AN: 450 (104.3)
Travel speed (Powershift Truck)	Loaded	mm/s (fpm)	19.0 (11.8)	19.0 (11.8)	19.0 (11.8)	19.0 (11.8)
	Unloaded	mm/s (fpm)	19.5 (12.1)	19.5 (12.1)	19.5 (12.1)	19.5 (12.1)

CLICK HERE TO **DOWNLOAD** THE COMPLETE MANUAL

- Thank you very much for reading the preview of the manual.
- You can download the complete manual from: [www.heydownloads.com](http://www.heydownloads.com) by clicking the link below



- Please note: If there is no response to CLICKING the link, please download this PDF first and then click on it.

CLICK HERE TO **DOWNLOAD** THE COMPLETE MANUAL

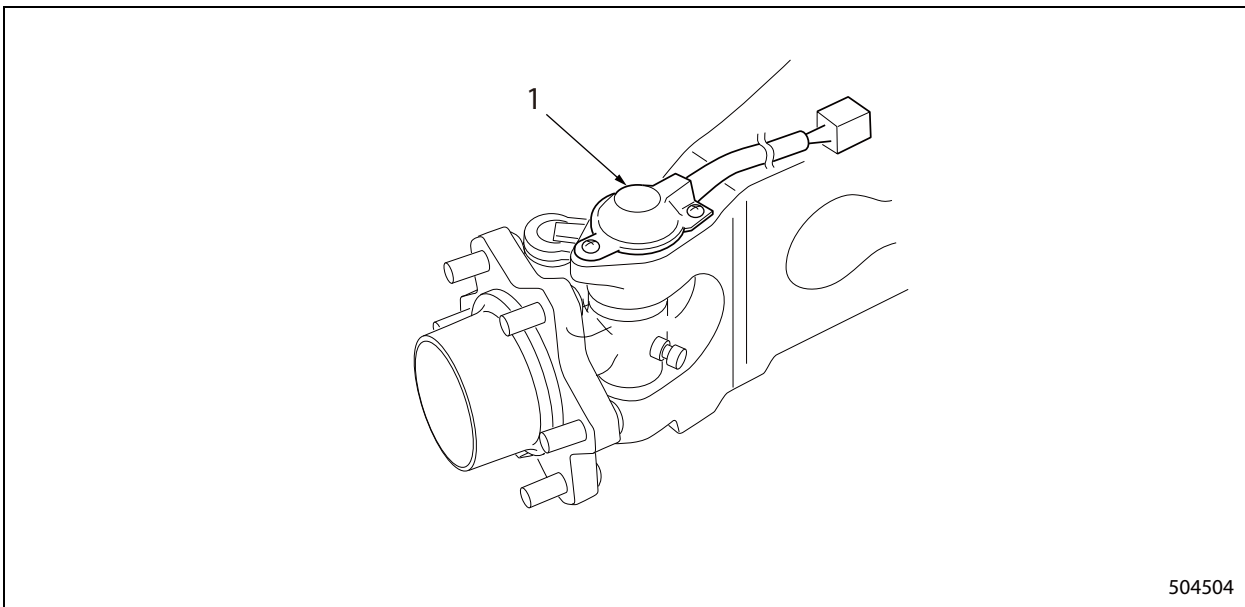

504504

1. Steering angle sensor

**Angle adjust solenoid valve (left side of frame)**

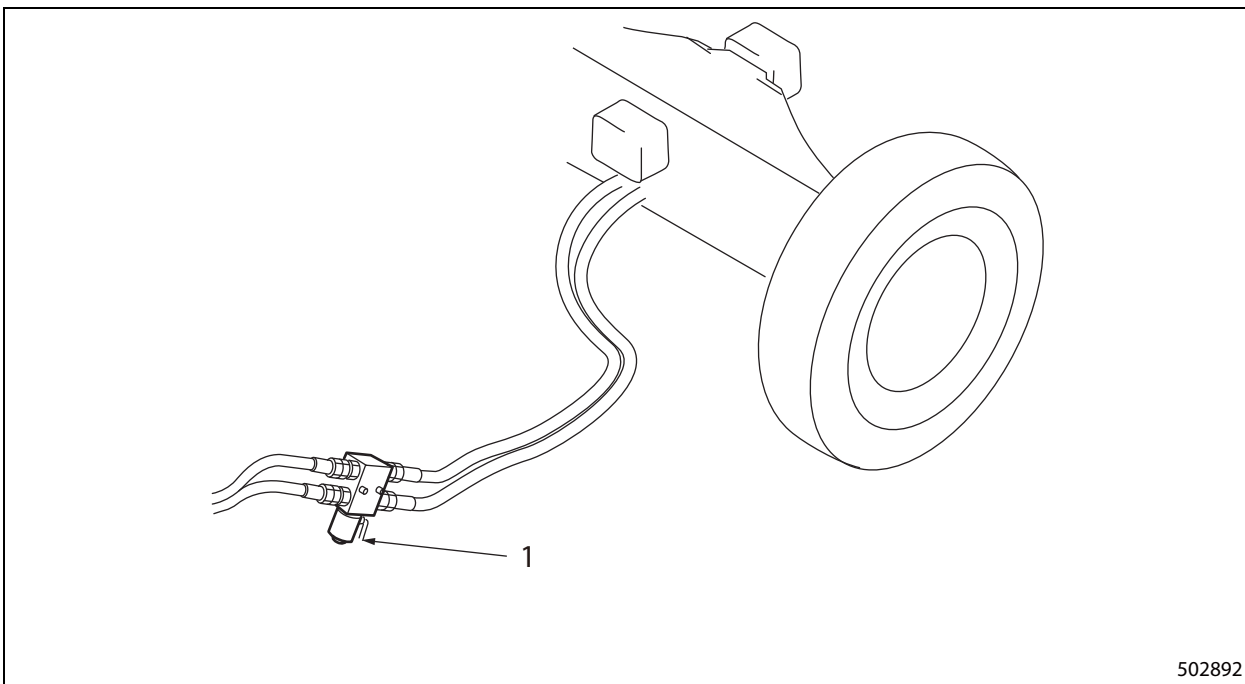

502892

1. Solenoid valve of power steering control valve

### 3.6 Steering Angle Sensor

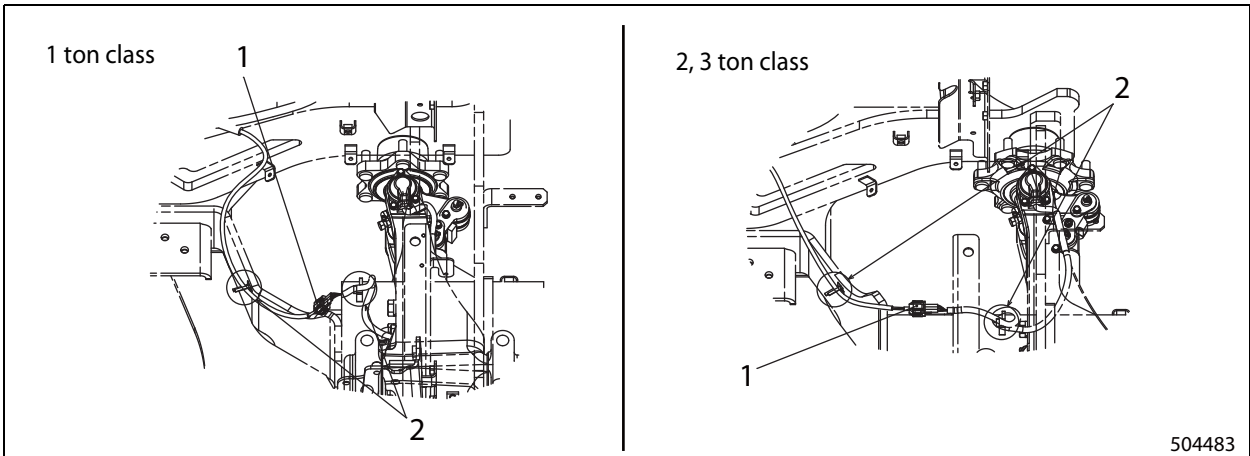

504483

1. Steering angle sensor

2. Clip to the frame.

### 3.7 Backup Buzzer

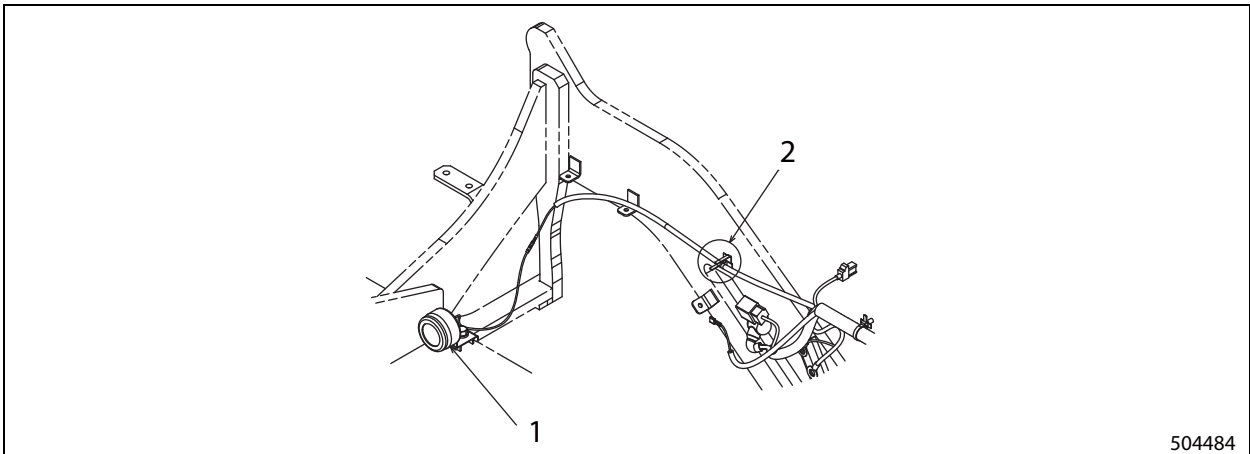

504484

1. Backup buzzer

2. Clip to the frame.

3.16 Rear Combination Harness

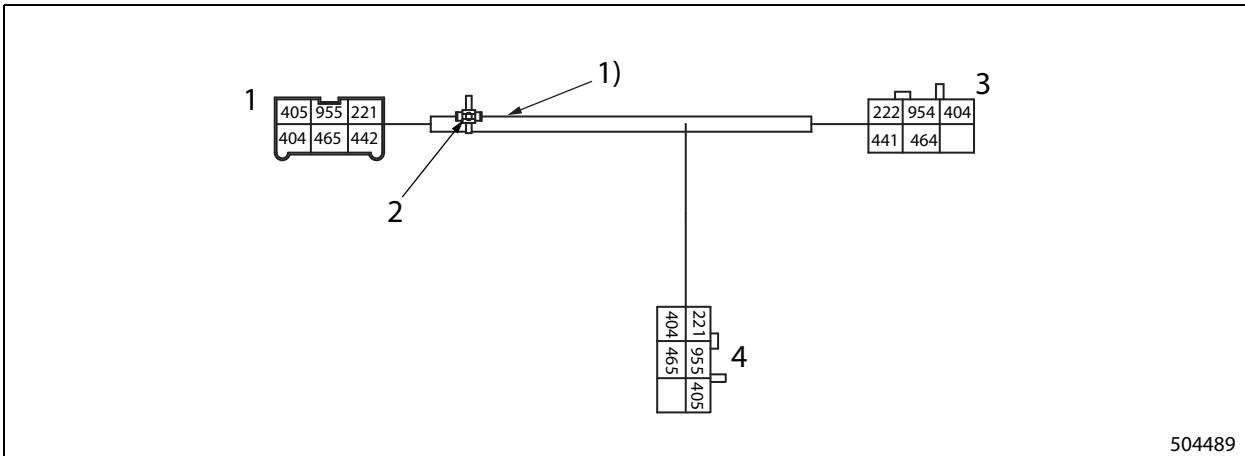

504489

- 1. Harness
- 2. Clip
- 3. Rear combination light (R.H.)
- 4. Rear combination light (L.H.)
- 1) Protect with corrugated tube

Note: Use AVS, CAVS or AVSS as the power source.

Circuit	Wire diameter	Wire color code	Destination
955	0.85	B	Rear combination light LH (GND) to harness
954	0.85	B	Rear combination light RH (GND) to 955
465	0.5	L/R	Rear combination light LH (backup light) to harness
464	0.5	L/R	Rear combination light RH (backup light) to 465
442	0.5	Y/L	Rear combination light LH (stop light) to harness
441	0.5	Y/L	Rear combination light RH (stop light) to 442
405	0.5	G/R	Rear combination light LH (turn signal light) to harness
404	0.5	G/B	Rear combination light RH (turn signal light) to harness
221	0.85	R/B	Rear combination light LH (tail light) to harness
222	0.5	R/B	Rear combination light RH (tail light) to 221

The LCD screen layout consists of six areas: main display, fuel gauge display, travel direction display, symbol display, clock/hour meter display, and coolant temperature display. Main display is divided into right and left areas.

Note: The meter panel has functions below to protect circuits in the panel.

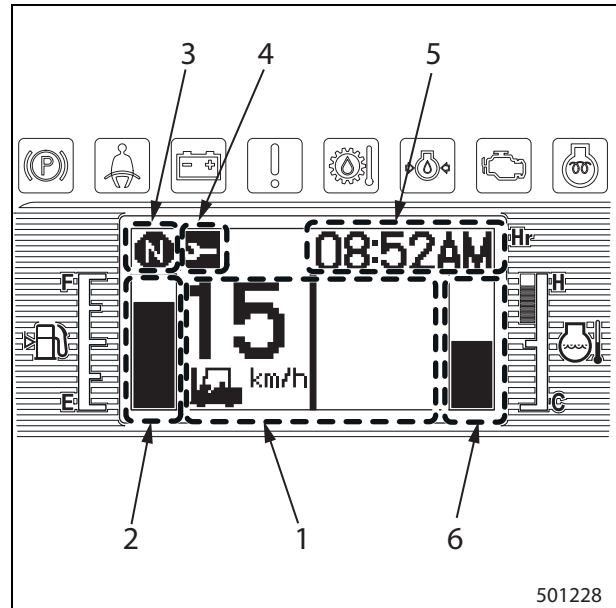

- 1. Main display
- 2. Fuel gauge display
- 3. Travel direction display
- 4. Symbol display (option)
- 5. Clock/hour meter display
- 6. Coolant temperature gauge

Meter panel inside (environment) temperature	-
85 °C (185 °F) or higher	LCD display on the screen automatically hides.
105 °C (221 °F) or higher	Back-up light goes off automatically.

Note: The LCD back-up light illuminates the fuel mark (left

- The LCD back-up light illuminates the fuel mark (left side) and coolant temperature mark (right side) on the LCD screen.
- For safety measures, warnings will not go off.
- When the temperature is extremely low (0 °C (32 °F) or below), the response of the LCD display becomes slower.

## 5.2 Basic Display

### Screen display with the key switch in the ON position

When the key switch is turned to the ON position, the LCD screen displays in the order of the brand logo screen, the password authentication screen, and the normal display screen. Also, truck history is displayed by the operation of button.

### Brand logo screen

When the key switch is turned to the ON position, the brand logo screen is displayed for 2 seconds while light check is being executed.

### 5.4 When A Warning Occurs

When a warning occurs, the corresponding diagnostic code is displayed on the screen. The order of warning display is; engine warnings, serious warnings and minor warnings. To erase the diagnostic code being displayed, remove a source of warning first, turn the key switch to the OFF position, then turn the key switch to the ON position again. (The diagnostic code will be kept to display until a cause of the trouble is solved.)

Note: Refer to "ENGINE SERVICE MANUAL" for the diagnostic codes related to engine warnings (diagnostic codes from ECM).

#### When an engine warning occurs

The diagnostic code on main display alternately changes between black characters on a white background to white characters on a black background. Also the engine warning light glows.

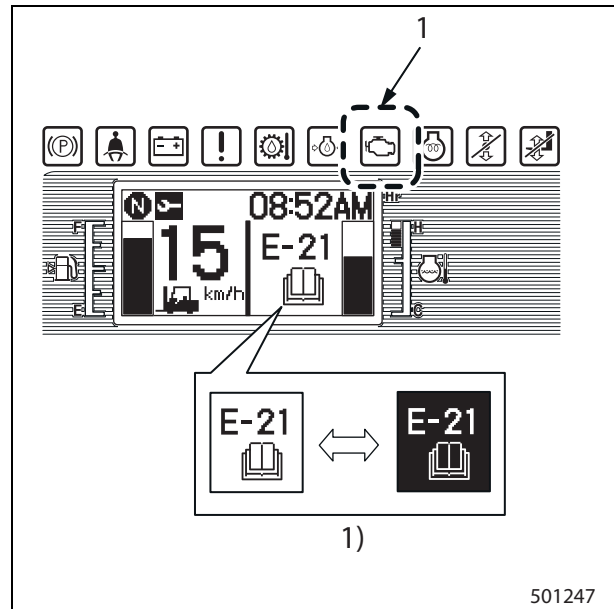

1. Engine warning light

1) The diagnostic code alternately changes between black characters on a white background to white characters on a black background.

#### When a serious warning occurs

The diagnostic code on main display alternately changes between black characters on a white background to white characters on a black background. Also all warning lights shown in the figure (right) will glow.

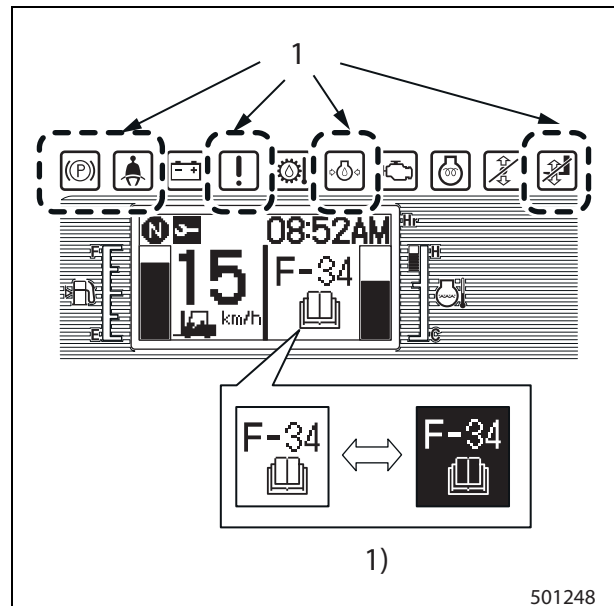

1. All of the warning lights blinks

1) The diagnostic code alternately changes between black characters on a white background to white characters on a black background.

Note: Set up the no setting on both screen A and B when the exterior alarm functions are unnecessary.

**Smart shift display (Maker option)**

The smart shift display function will notify an operator of the lift truck condition by the smart shift light glowing when the smart shift function activates against a full reverse or sudden acceleration. For setting up the smart shift display, use the service tool. (For details, see the service tool manual.)

Note: ONLY a service engineer should perform the smart shift function setting.

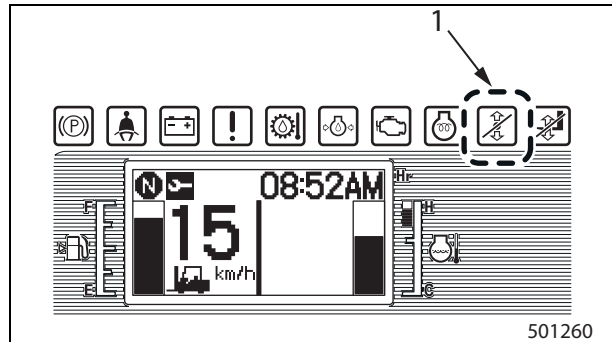

1. Smart shift indicator light

**Speed restriction function (Manufacturer's option for diesel model only)**

Speed restriction function will limit the maximum speed to both high and low pre-set speeds. H/L selector switch is used to change between high and low speeds. For setting up the speed restriction function, use the service tool. (For details, see the service tool manual.)

Note:

- Service engineers should perform the speed restriction function setting.
- Gasoline modeled include this function as a standard function.

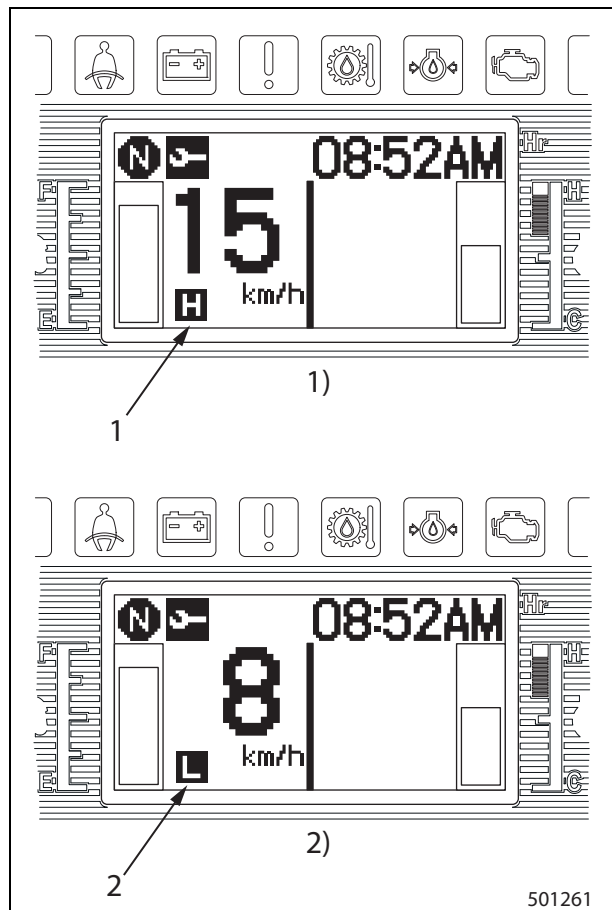

1. High speed symbol                      1) High speed limit display  
 2. Low speed symbol                     2) Low speed limit display

# Electrical Schematic (1/4)

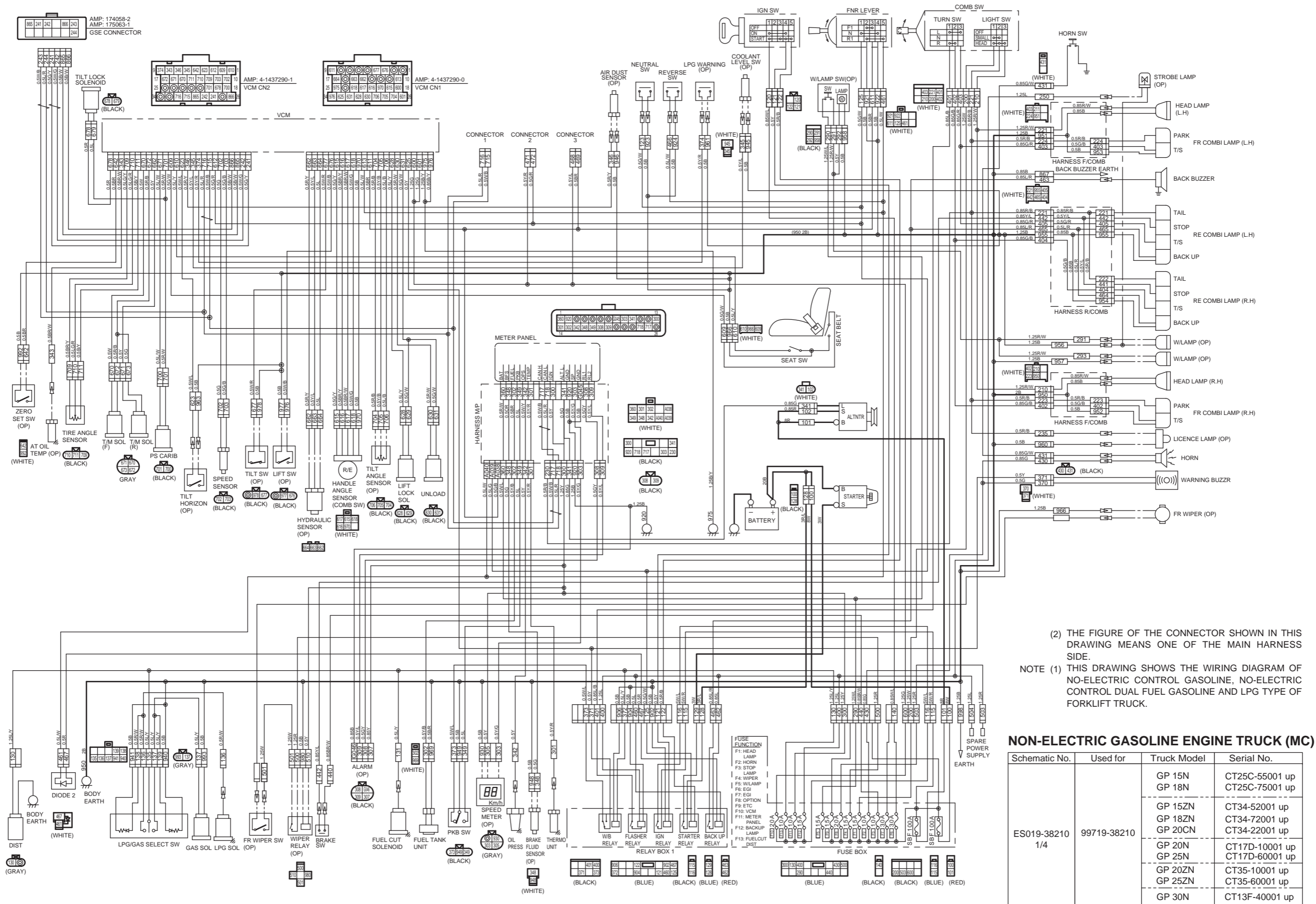

(2) THE FIGURE OF THE CONNECTOR SHOWN IN THIS DRAWING MEANS ONE OF THE MAIN HARNESS SIDE.  
 NOTE (1) THIS DRAWING SHOWS THE WIRING DIAGRAM OF NO-ELECTRIC CONTROL GASOLINE, NO-ELECTRIC CONTROL DUAL FUEL GASOLINE AND LPG TYPE OF FORKLIFT TRUCK.

## NON-ELECTRIC GASOLINE ENGINE TRUCK (MC)

Schematic No.	Used for	Truck Model	Serial No.
ES019-38210 1/4	99719-38210	GP 15N	CT25C-55001 up
		GP 18N	CT25C-75001 up
		GP 15ZN	CT34-52001 up
		GP 18ZN	CT34-72001 up
		GP 20CN	CT34-22001 up
		GP 20N	CT17D-10001 up
		GP 25N	CT17D-60001 up
		GP 20ZN	CT35-10001 up
		GP 25ZN	CT35-60001 up
		GP 30N	CT13F-40001 up

Primary function of each control is described below.

## **2.1 Meter panel**

The meter panel is located below the steering wheel. It displays traveling speed, time and truck status. For the other functions, refer to CHAPTER "ELECTRICAL SYSTEM".

## **2.2 VCM -1M (Vehicle Control Module)**

The VCM controller is located on the right side of the truck and controls the whole truck system (driving/mast interlock system, steering wheel knob deviation correction, etc.)

## **2.3 ECM (Gasoline Engine Control Module)**

The ECM controller is located on the left side of the truck and controls the gasoline engine. Refer to "ENGINE SERVICE MANUAL" for details.



- (8) The unload solenoid output and the lift lock solenoid output will turn OFF when the mast interlock system is activated.

Under this condition, operate the lift lever to make sure that the forks will not move up and down. Also operate the tilt lever to make sure that the mast will not tilt forward and backward.

Item	Normal Range	Value
Solenoid output (ATT3 valve 2) outp...	* - *	0
Solenoid output (ATT3 valve) feedba...	* - *	0
Solenoid output (ATT3 valve 1) output	* - *	Normal
Solenoid output (ATT3 valve 2) output	* - *	Normal
Solenoid output (ATT3 valve) status	* - *	Normal
PWM voltage (RI01) [V]	* - *	0
PWM voltage (RI01)	* - *	Normal
Unload solenoid	* - *	OFF
Unload solenoid feedback [mA]	* - *	9.67
Liftlock solenoid	* - *	OFF
Liftlock solenoid feedback [mA]	* - *	9.67
Tiltlock solenoid feedback [mA]	* - *	19.35
Park brake alarm	* - *	OFF
Over load alarm 1	* - *	OFF
Over speed alarm	* - *	OFF
Angle adjust solenoid	* - *	OFF
Angle adjust tilt lock current [mA]	* - *	19.35
Auto light OUT	* - *	OFF
AUX out 1	* - *	OFF
AUX out 2	* - *	OFF
AUX out 3	* - *	OFF
Limp home	* - *	OFF

501343

**If Seat switch is not turned on**

Check the seat switch operation and wiring connections by referring to 4-38 "Harness Codes", 4-40 "VCM-1M Controller", and 4-44 "Seat Switch".

**If unload solenoid is not turned on**

Check the solenoid output according to 4-24 "Active Test Inspection Procedure". If the solenoid output will not turn ON even after the active test inspection, refer to 4-51 "Truck Status Display and Troubleshooting" and check for the possible causes of the diagnostic code F-75 and F-79.

**If lift lock solenoid is not turned on**

Check the solenoid output according to 4-24 "Active Test Inspection Procedure". If the solenoid output will not turn ON even after the active test inspection, refer to 4-51 "Truck Status Display and Troubleshooting" and check for the possible causes of the diagnostic code F-77 and F-79.

## 6.2 Seat Belt Warning Light, Checking the Operation

- (1) Connect the service tool to the VCM-1M controller.
- (2) Turn the key switch to the ON position and start the engine.
- (3) Display the input monitor screen of the service tool.
- (4) Make sure that the seat switch status is turned OFF when the seat belt is not fastened or not buckled properly. Also check that the seat belt warning light in the meter panel glows.

Item	Normal Range	Value
Seat Switch	* - *	ON
Seat Switch timer	* - *	ON
Seatbelt Switch	* - *	OFF
Accel Switch	* - *	ON
Park brake Switch	* - *	ON
Direction lever F	* - *	OFF
Direction lever N	* - *	ON
Direction lever R	* - *	OFF
FNR lever	* - *	Neutral
Joystick (Lift lever 1) signal [%]	-100 - 100	0
Joystick (Lift lever 1) status	* - *	Normal
Joystick (Lift lever 2) signal [%]	-100 - 100	0
Joystick (Lift lever 2) status	* - *	Normal
Joystick (Tilt lever 1) signal [%]	-100 - 100	0
Joystick (Tilt lever 1) status	* - *	Normal
Joystick (Tilt lever 2) signal [%]	-100 - 100	0
Joystick (Tilt lever 2) status	* - *	Normal
Joystick (ATT1 lever 1) signal [%]	-100 - 100	0
Joystick (ATT1 lever 1) status	* - *	Normal
Joystick (ATT1 lever 2) signal [%]	-100 - 100	0
Joystick (ATT1 lever 2) status	* - *	Normal
Joystick (ATT2 lever 1) signal [%]	-100 - 100	0
Joystick (ATT2 lever 1) status	* - *	Normal
Joystick (ATT2 lever 2) signal [%]	-100 - 100	0
Joystick (ATT2 lever 2) status	* - *	Normal

501411

### If Seat belt switch does not indicate ON

Check the seat belt switch operation and wiring connections by referring to 4-38 "Harness Codes", 4-40 "VCM-1M Controller", and 4-44 "Seat Switch".

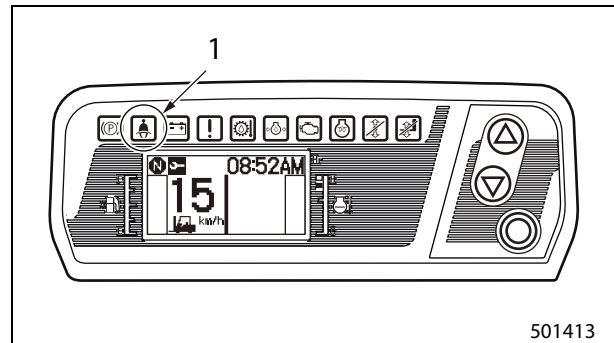

1. Lighting

- (5) Make sure that the seat belt switch turns ON and the seat belt warning light in the meter panel goes out when the seat belt is properly fastened.

Item	Normal Range	Value
Seat Switch	* - *	ON
Seat Switch timer	* - *	ON
Seatbelt Switch	* - *	ON
Accel Switch	* - *	ON
Park brake Switch	* - *	ON
Direction lever F	* - *	OFF
Direction lever N	* - *	ON
Direction lever R	* - *	OFF
FNR lever	* - *	Neutral
Joystick (Lift lever 1) signal [%]	-100 - 100	0
Joystick (Lift lever 1) status	* - *	Normal
Joystick (Lift lever 2) signal [%]	-100 - 100	0
Joystick (Lift lever 2) status	* - *	Normal
Joystick (Tilt lever 1) signal [%]	-100 - 100	0
Joystick (Tilt lever 1) status	* - *	Normal
Joystick (Tilt lever 2) signal [%]	-100 - 100	0
Joystick (Tilt lever 2) status	* - *	Normal
Joystick (ATT1 lever 1) signal [%]	-100 - 100	0
Joystick (ATT1 lever 1) status	* - *	Normal
Joystick (ATT1 lever 2) signal [%]	-100 - 100	0
Joystick (ATT1 lever 2) status	* - *	Normal
Joystick (ATT2 lever 1) signal [%]	-100 - 100	0
Joystick (ATT2 lever 1) status	* - *	Normal
Joystick (ATT2 lever 2) signal [%]	-100 - 100	0
Joystick (ATT2 lever 2) status	* - *	Normal

501416

## VCM-1M controller signal allocation (CN2)

Pin No.	Circuit No.	MC	Signal name
1	610	○	Seat switch
2	609	○	Seatbelt Switch
3	612	○	FNR lever switch (N)
4	623	○	Tilt auto-stop switch
5	642	○	Weight 0 set switch
6	345	○	Coolant level switch
7	346	○	Air cleaner clog switch
8	343	○	T/M warning switch (Torque converter oil temperature)
9	374	○	Fuel warning switch
10	702	○	Speed sensor signal (+)
11	703	○	Speed sensor signal (-)
12	709	○	Wheel angle sensor power supply (+5 V)
13	710	○	Wheel angle signal
14	711	○	Wheel angle sensor GND
15	670	○	Transmission solenoid F output
16	671	○	Transmission solenoid R output
17	672	○	Transmission control valve return
18	700	○	Power steering control solenoid output
19	678	○	Tilt lock solenoid output
20	701	○	Power steering/tilt lock solenoid return
21	-	-	
22	-	-	
23	-	-	
24	-	-	
25	-	-	
26	866	○	GND
27	-	-	
28	241	○	RX-232 Tx
29	242	○	RX-232 Rx
30	865	○	RX-232 GND
31	715	○	CAN H
32	716	○	CAN L
33	-	-	
34	-	-	

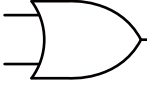
Diagnosis	VCM Battery voltage warning (F02)	
Logic conditions	<ul style="list-style-type: none"> <li>· Power supply voltage is 7 V or less (1-second continuity)</li> <li>· Power supply voltage is 21 V or more (1-second continuity)</li> </ul>	 F02
Recovery	Auto recovery	
Action	· Turn OFF all solenoid outputs.	
LED blink pattern	B	

Diagnosis	VCM communication warning (F03)	
Logic conditions	· CAN transmission from VCM-1M is not available. (2-second continuity)	 F03
Recovery	Auto recovery	
Action	· Warning indication only, the operation continues.	
LED blink pattern	B	

Diagnosis	ECM Communication warning (F04)	
Logic conditions	· No CAN sent from ECM. (2-second continuity)	 F04
Recovery	Auto recovery	
Action	· Activates with default values of ECM incoming data.	
LED blink pattern	B	

Diagnosis	DCM communication warning (F05)	
Logic conditions	· No CAN received from DCM. (2-second continuity)	 F05
Recovery	Auto recovery	
Action	· Activates with default values of DCM incoming data.	
LED blink pattern	B	

Diagnosis	OCM communication warning (F06)	
Logic conditions	· No CAN received from OCM. (2-second continuity)	 F06
Recovery	Auto recovery	
Action	· Activates with default values of OCM incoming data.	
LED blink pattern	B	

Diagnosis	MP Communication warning (F07)	
Logic conditions	· No CAN received from meter panel. (2-second continuity)	 F07
Recovery	Auto recovery	
Action	· Activates with default values of metal panel incoming data.	
LED blink pattern	B	

Diagnostic code	Diagnostic code name	Probable cause	Check items
F-38	Tilt angle sensor warning	1. Connector contact bad	1. Link connection and damage check
			2. Connector connection check
		2. Harness bad	3. Harness connection check
		3. Tilt angle sensor bad	4. Sensor connection check
		4. Controller bad	
F-40	Steering warning	1. Connector contact bad	1. Connector connection check
		2. Harness bad	2. Harness connection check
		3. Wheel angle sensor bad	3. Sensor connection check
		4. Controller bad	
F-73	Hour meter gap warning	1. Hour meter time difference between VCM and M/P.	1. Connect service tool and update #252 M/P hour meter.
F-75	Unload solenoid warning	1. Connector contact bad	1. Connector connection check
		2. Diode bad	2. Diode connection check
		3. Harness bad	3. Harness connection check
		4. Unload solenoid bad	4. Unload solenoid connection check
		5. Controller bad	
F-77	Lift lock solenoid warning	1. Connector contact bad	1. Connector connection check
		2. Diode bad	2. Diode connection check
		3. Harness bad	3. Harness connection check
		4. Lift lock solenoid bad	4. Lift lock solenoid connection check
		5. Controller bad	
F-79	Unload solenoid leak	1. Connector contact bad	1. Connector connection check
		2. Diode bad	2. Diode connection check
		3. Harness bad	3. Harness connection check
		4. Unload solenoid bad	4. Unload solenoid connection check
		5. Controller bad	
F-80	Power steering correction valve solenoid warning	1. Connector contact bad	1. Connector connection check
		2. Diode bad	2. Diode connection check
		3. Harness bad	3. Harness connection check
		4. Power steering correction valve solenoid bad	4. Power steering correction valve solenoid connection check
		5. Controller bad	

## 1.2 Suggestions for Removal of Overhead Guard, Air Cleaner and Others

### Overhead guard, head light

- (1) Remove the connector from the head light harness.
- (2) Hitch a sling to the overhead guard, and remove it by lifting with a hoist.

Item	Weight
Overhead guard	Approx. 75 kg (165.3 lb.)

### Battery

Always disconnect the negative battery cable first when removing a battery.

### Steering wheel

For removing the steering wheel, refer to CHAPTER "STEERING SYSTEM".

Note: Do not remove the steering shaft.

### Gas spring

## ⚠ WARNING

Open the engine cover and hold it to remove the gas spring and engine cover. The engine cover can fall and your hands may be caught under the cover.

### Floor plate, Floor mat

Remove the floor plate and floor mat.

### Air hose, Air cleaner

Cover the air intake port to prevent dust and foreign objects from entering when air hose and air cleaner are removed.

### Exhaust pipe

Disconnect the exhaust pipe at the engine side.

### Fuel hose

Before removing the fuel hose, make sure to close the drain cock on the fuel tank.

### Harness connector

After disconnecting the harness connectors from the sockets and terminals on the engine and transmission they should be attached to the main harness in order to avoid damaging them.

## ⚠ CAUTION

Be sure to release fuel pressure before disconnecting the fuel hoses from the electronic controlled engine models.

### Pressure release from fuel line

- (1) Remove the fuel pump fuse (QGS/OTHERS 10A).
- (2) Turn the key switch to the (START) position and run the engine for a few seconds to release the pressure from the fuel line.
- (3) Turn the key switch to the (OFF) position, and install the fuel pump fuse.
- (4) To release the pressure from fuel tank, remove the cap from fuel tank once, and install the cap.

## 2.5 Preparation for Removing Pipes and Radiator (Manual T/M Truck)

- (1) Drain the coolant from the radiator by loosening the drain cock at the bottom of the radiator.
- (2) Drain coolant from the engine by removing the drain plug.

## 2.6 Removal Sequence of Pipes and Radiator (Manual T/M Truck)

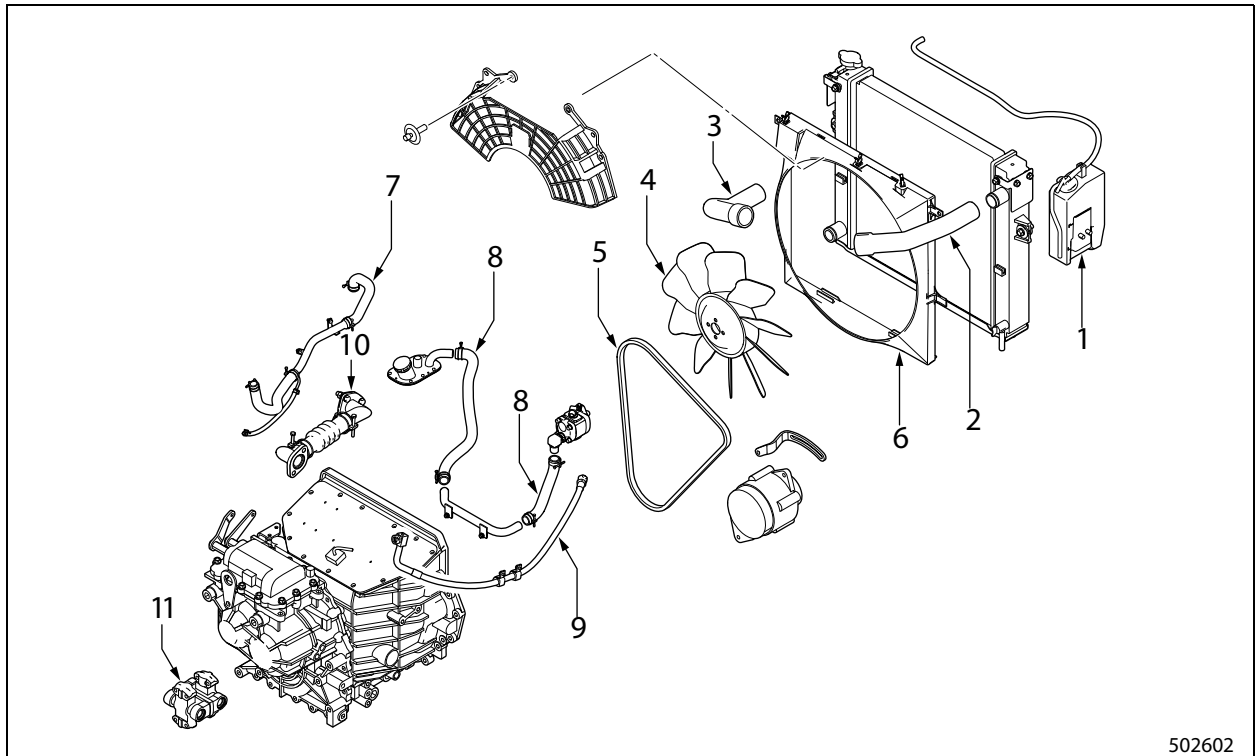

502602

- |  |   |
|--|---|
| 1. Reserve tank                                    | 8. Hose (between hydraulic tank and oil pump)                               |
| 2. Hose (upper)                                    | 9. Hose (between oil pump and steering control valve)                       |
| 3. Hose (lower)                                    | 10. Hose (between transmission and hydraulic tank) (wet-type clutch only)   |
| 4. Cooling fan                                     | 11. Universal joint (between transmission and reduction/differential gears) |
| 5. Fan belt  |   |
| 6. Fan guard                                       |   |
| 7. Hose (between hydraulic tank and control valve) |   |

## 2.7 Suggestions for Installing Pipes and Radiator (Manual T/M Truck)

For installation, follow the removal sequence in reverse.  
Before connecting hoses to pipes, clean the mating joint surfaces of pipes and hoses.

## 2. Clutch Assembly, Disassembling

### 2.1 Disassembly Sequence

The input shaft of the manual transmission is a type that can be split from the internal gearing.

Because of this structure, the plate assembly, clutch disc, release bearing, etc. can be removed and installed without removing the transmission assembly.

However, when removing fork, clutch shaft, it is necessary to remove the engine/transmission assembly from the truck body. (If the engine/transmission assembly is not removed, there is no room to remove the clutch shaft.)

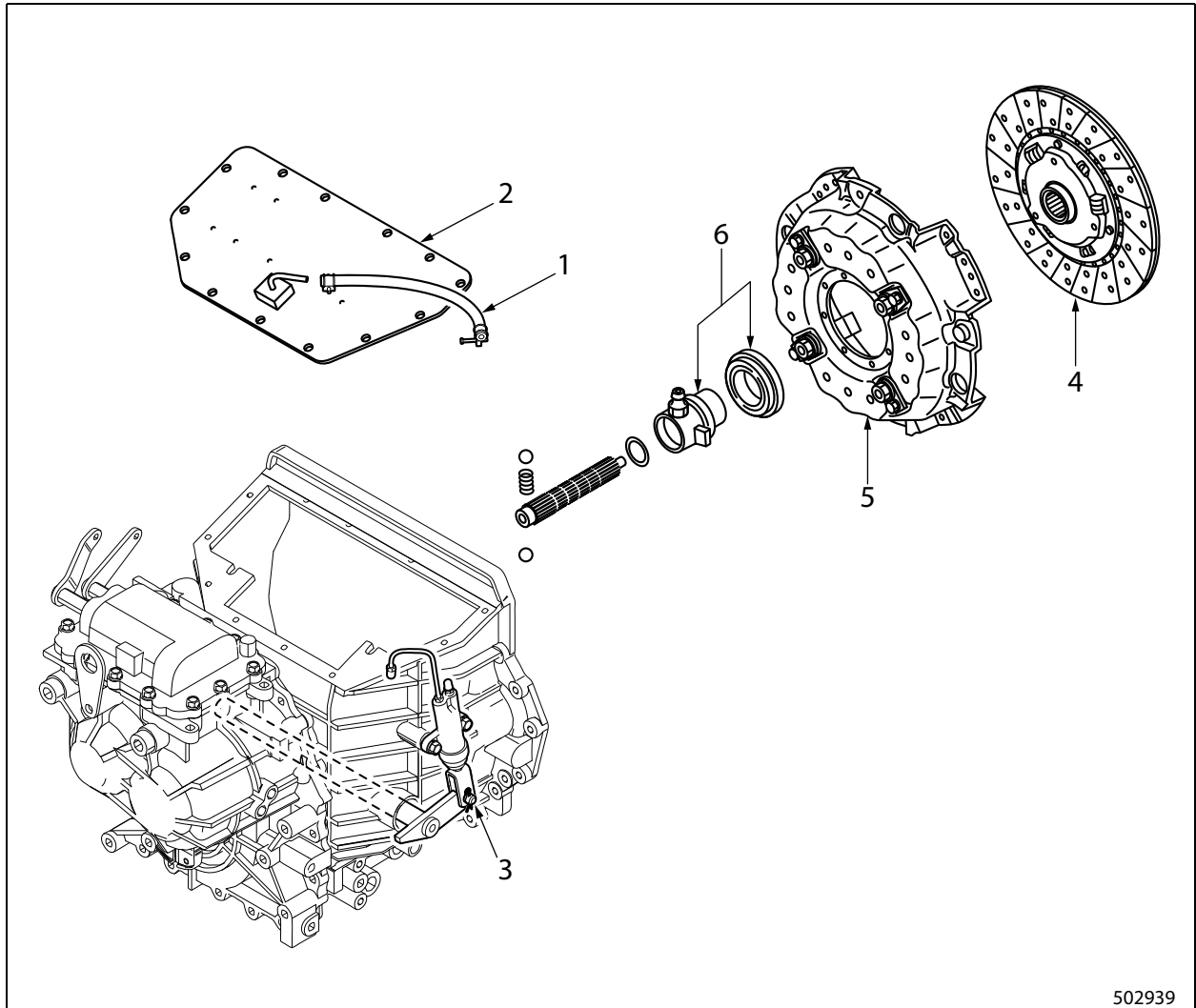

502939

- |                                |                                    |
|--------------------------------|------------------------------------|
| 1. Hose (wet type only)        | 4. Clutch disc                     |
| 2. Clutch cover                | 5. Pressure plate assembly         |
| 3. Clutch release cylinder pin | 6. Release bearing, Clutch shifter |

**Clutch cover**

Check the clutch cover for distortion, cracks, deformation and wear.

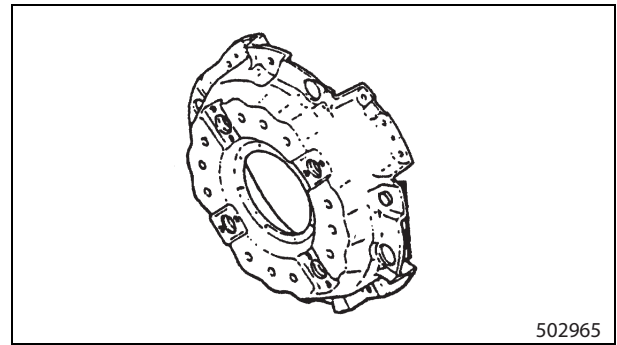

502965

**Release levers**

Check each release lever for wear or damage on the contact and sliding surfaces.

**7. Pressure Assembly, Assembling**

For assembly, follow the disassembly sequence in reverse.

**7.1 Suggestions for Assembly**

**Bolt tightening torque**

- Tighten the bolts with strap fixing washers 3 to the torque specified below.

Item	Tightening torque
Strap fixing washer mounting bolt	39 to 59N·m (4.0 to 6.0 kgf·m) [28.76 to 43.52 lbf·ft]

- Tighten the bolts that hold locking plates 1 to the torque specified below.

Item	Tightening torque
Lockplate mounting bolts	5.8 to 7.8 N·m (0.59 to 0.80 kgf·m) [4.278 to 5.753 lbf·ft]

**Applying grease**

Apply molybdenum disulfide grease (Never Seez or equivalent) to the pressure plate of the dry type clutch at the following places.

- Contact surfaces of release lever and pressure plate.
- Contact surfaces of release lever and lever support.

Also apply anti-seize and lubricating compound (Never Seez grease) to the following parts.

- Support nut threaded portion
- Support nut spherical portion

## 15. Checking Clutch Disc for Wear

The clutch release cylinder automatically compensates for changes in the position of the release levers of the pressure plate assembly due to clutch disc wear. There is no need for pedal adjustment once the pedal is adjusted at the time of assembly. However, measure the wear of clutch disc as instructed below so that you will know when it is the right time to replace clutch disc.

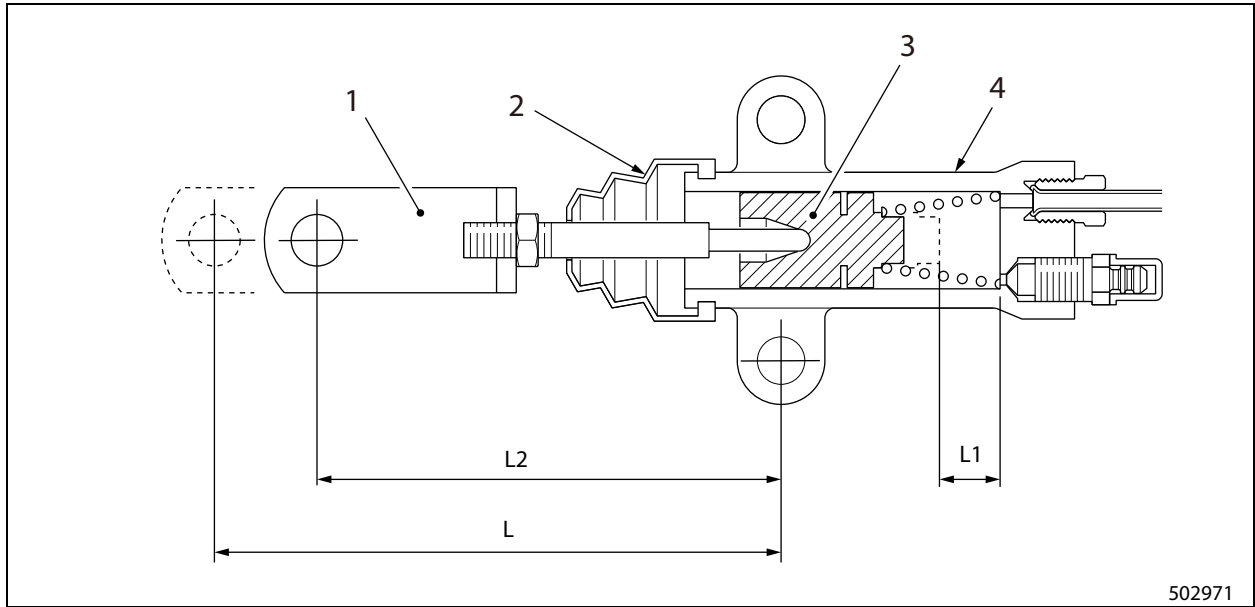

502971

- 1. Push rod complete
- 2. Boot
- 3. Piston
- 4. Body

L : Dimension when release cylinder is assembled (mm)

L1: Dimension when release cylinder is installed to clutch shifter shaft (when clutch disc is new)

L2: Dimension between centers of cylinder body mounting bolt hole and mounting pin hole

- (1) After the clutch release cylinder is installed in accordance with the clutch pedal adjustment procedure described above, measure L2 and record the measurement.

Note: L2 may deviate from the specified standard value due to error in the installed dimensions of parts, their free play, etc.

- (2) As the clutch disc wears, the piston is pushed further little by little, which results in a decrease in L2 dimension. During monthly inspection, measure L2 and if the measurement exceeds the limit, replace the clutch disc.

Item		Specified value	
L1 (reference value)	Dry type clutch	Standard	22 mm (0.87 in.)
	Wet type clutch	Standard	17 mm (0.67 in.)

Item		Specified value	
L2 dimension	Dry type clutch	Standard	105.9 ± 0.5 mm (4.169 ± 0.019 in.)
	Wet type clutch	Standard	100.9 ± 0.5 mm (3.972 ± 0.019 in.)



## 8. Synchro-shaft Assembly, Disassembly

### 8.1 Disassembly Sequence

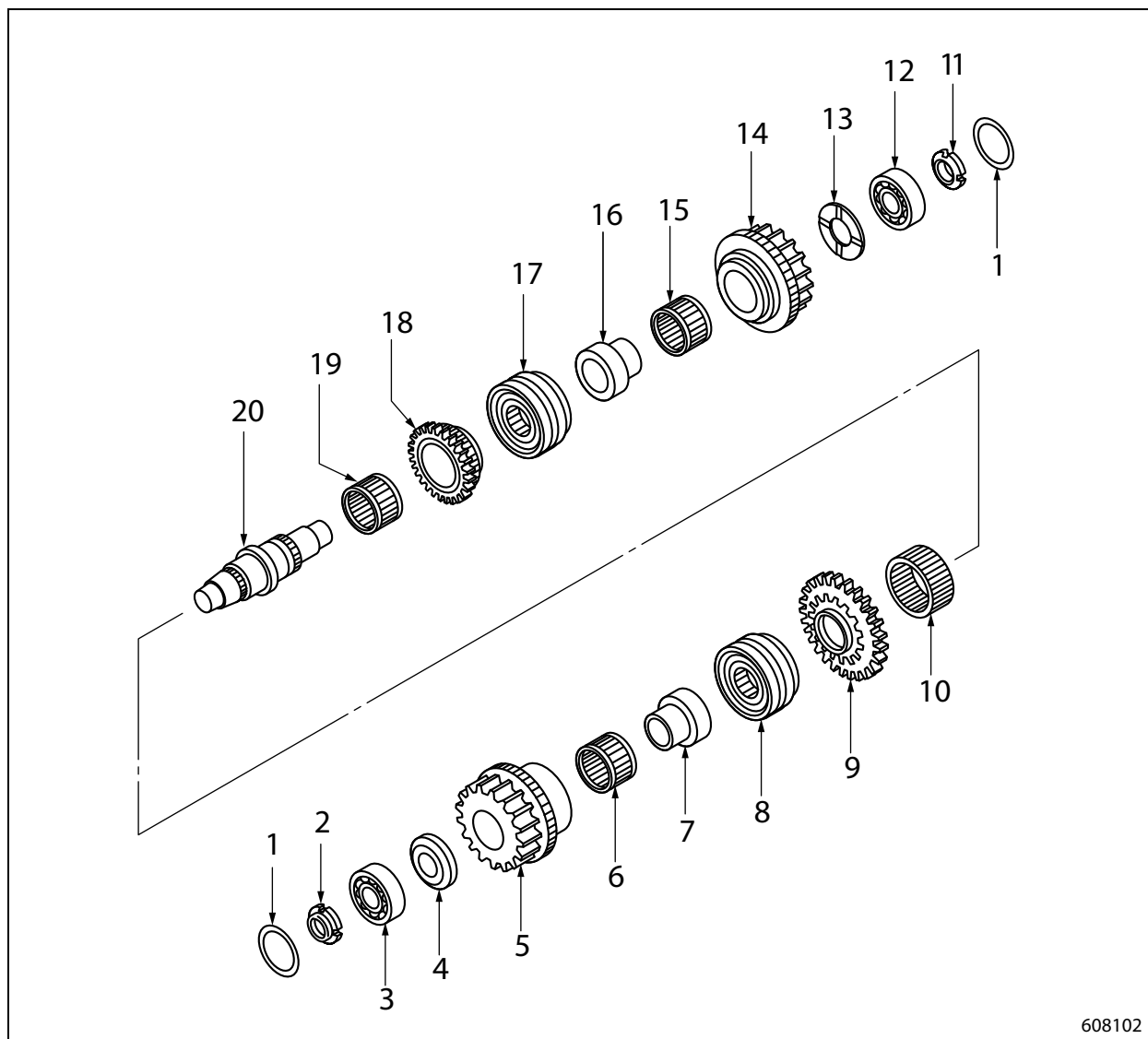

608102

- |                               |                                |
|-------------------------------|--------------------------------|
| 1. Shim                       | 11. Nut                        |
| 2. Nut                        | 12. Roller bearing             |
| 3. Roller bearing             | 13. Thrust washer              |
| 4. Thrust washer              | 14. Forward gear               |
| 5. High gear                  | 15. Needle roller bearing      |
| 6. Needle roller bearing      | 16. Synchro-sleeve             |
| 7. Synchro-sleeve             | 17. Synchromesh assembly (F-R) |
| 8. Synchromesh assembly (H-L) | 18. Reverse gear               |
| 9. Low gear                   | 19. Needle roller bearing      |
| 10. Needle roller bearing     | 20. Main shaft                 |

- (6) Apply a thin coat of grease (LG2) to oil seal lips before installing.
- (7) Install the output flange while making sure not to damage the oil seal.

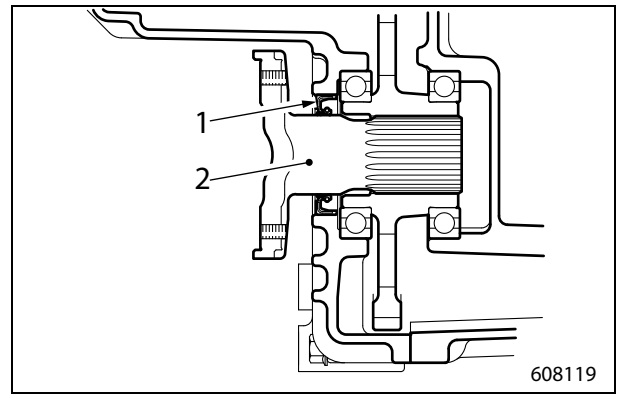

1. Oil seal

2. Output flange

1.3 Transmission Components

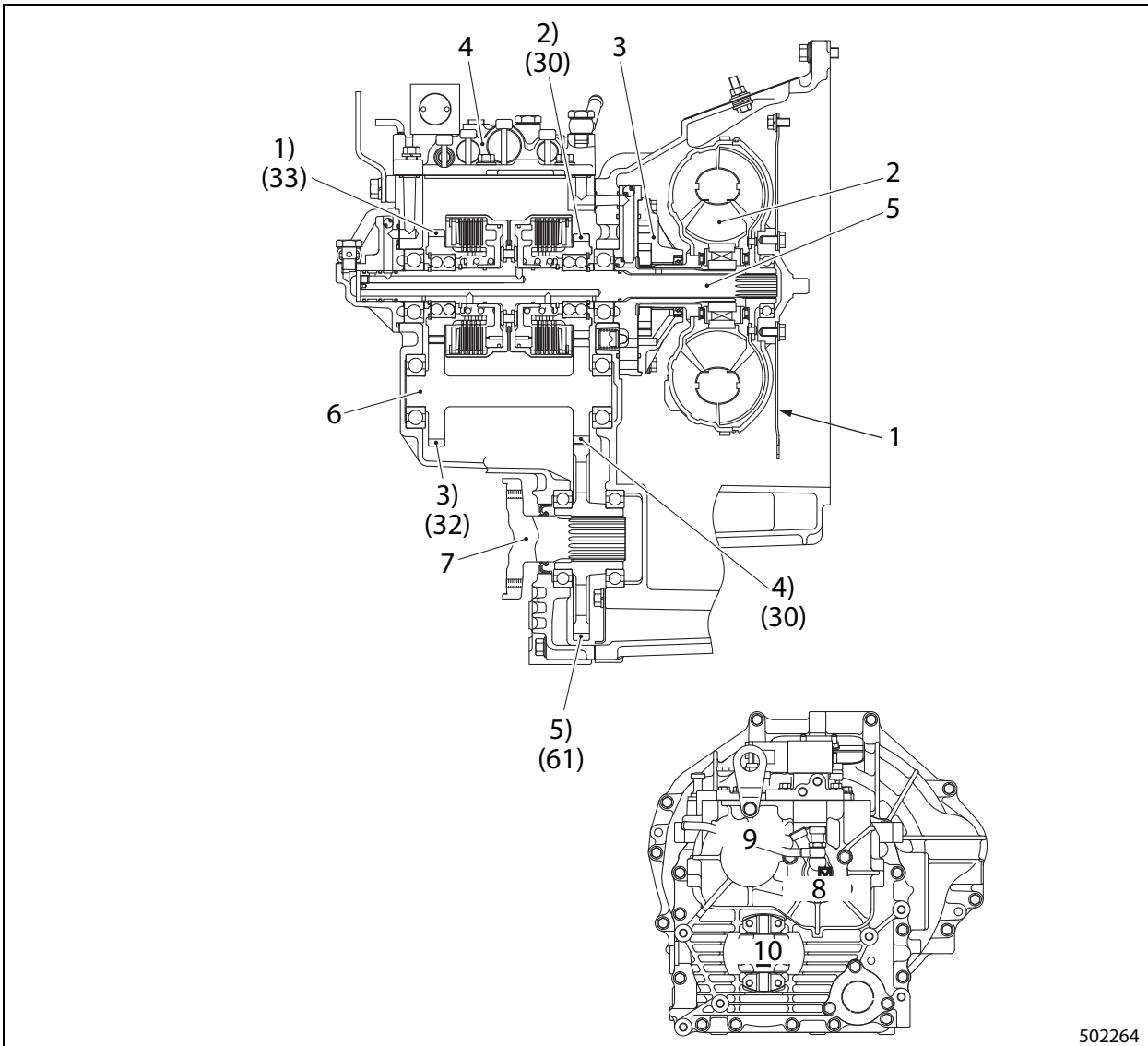

502264

- |                               |                      |
|-------------------------------|----------------------|
| 1. Flexible plate             | 1) Forward gear (33) |
| 2. Torque converter assembly  | 2) Reverse gear (30) |
| 3. Oil pump assembly          | 3) Idler gear (32)   |
| 4. Control valve              | 4) Idler gear (30)   |
| 5. Input shaft (No. 1 shaft)  | 5) Output gear (61)  |
| 6. Idler shaft (No. 2 shaft)  |                      |
| 7. Output shaft (No. 3 shaft) |                      |
| 8. No. 1 shaft                |                      |
| 9. No. 2 shaft                |                      |
| 10. No. 3 shaft               |                      |

Note: Number of gear teeth is shown in the ( ).

- (3) Lift the transmission with the stand kit, and lay it so that the transmission housing side faces up.

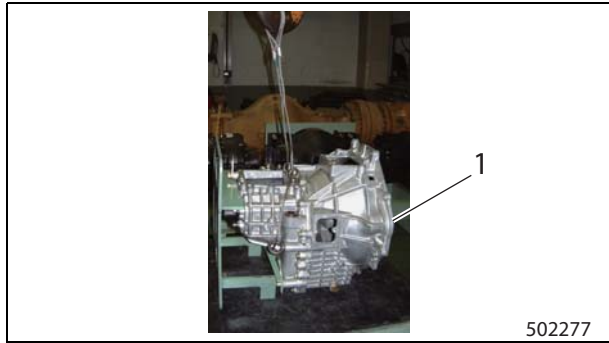

1) Housing side



- (4) Remove two bolts from the flexible plate and install two eye bolts.  
(5) Remove the wire that is used to prevent the torque converter assembly from slipping out.  
(6) Lift the torque converter assembly with a hoist.

Note:

- The torque converter assembly cannot be disassembled.
- Oil will flow out when pulling out the torque converter assembly. Position an oil pan to catch oil.



### 4.10 Forward Side Input Shaft Gear Assembly, Disassembling

#### Forward gear assembly, Removing

- (1) Place the input shaft gear assembly on the clutch pack stand kit (special tool) with the forward gear side facing up.

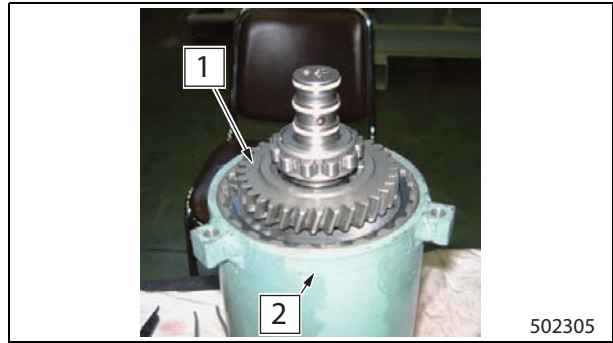

1. Forward gear                      2. Special tool (Stand)

Special tool		Part number
Clutch pack stand kit		91A68-00010
Clutch pack stand kit components	Stand	91A68-01300
	Plate 1	91A68-01400
	Plate 2	91A68-01500
	Bolt	67284-15400

- (2) Using a flat head screwdriver, pry up bearing together with input spacer.

Note: When prying up, be sure to insert the tip of the screwdriver under the input spacer. Otherwise, the bearing cage may be damaged.

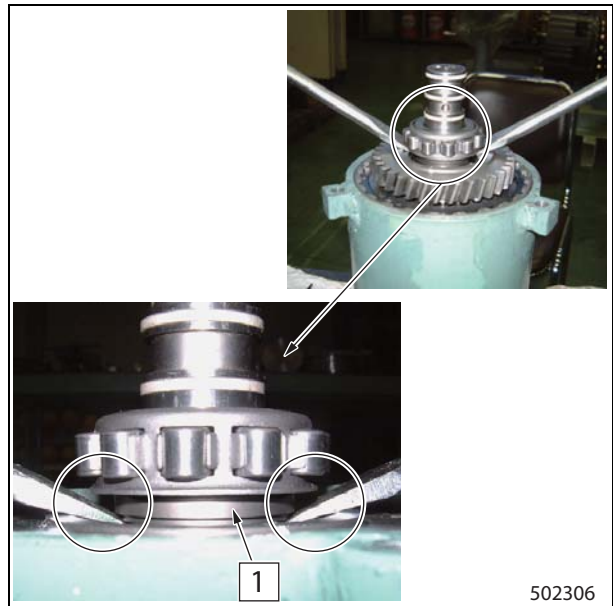

1. Input spacer

## 5.2 Idler Shaft Assembly, Assembling

### Forward gear side, Assembling

- (1) Place idler shaft on the stand (special tool).
- (2) Install torque converter housing side bearing using remover (special tool).

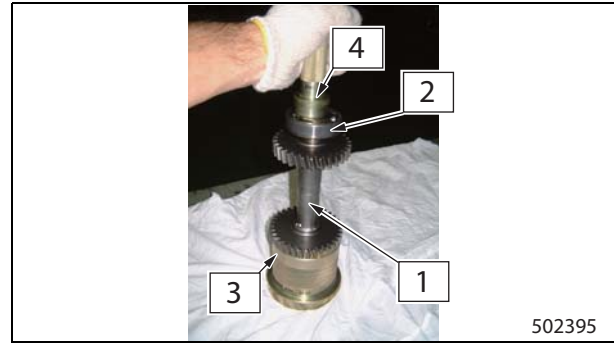

- |                |                           |
|----------------|---------------------------|
| 1. Idler shaft | 3. Special tool (stand)   |
| 2. Bearing     | 4. Special tool (Remover) |

Special tool	Part number
Stand	91A68-01700
Remover	91A68-01900

### Idler shaft on output gear side, Assembling

Reassemble in the same manner as forward gear side.

## 5.3 Output Gear Assembly, Assembling

### Output gear on transmission housing side, Assembling

- (1) Place output gear on the stand (special tool).
- (2) Install transmission housing side bearing using the installer/remover (special tool).

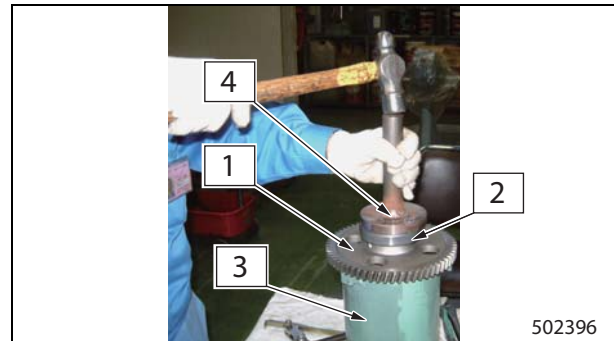

- |                |                                     |
|----------------|-------------------------------------|
| 1. Output gear | 3. Special tool (stand)             |
| 2. Bearing     | 4. Special tool (Installer/Remover) |

Special tool	Part number
Stand	91A68-01300
Installer/remover	91A68-02300

### Output gear on torque converter housing side, Assembling

Reassemble in the same manner as transmission housing side above.

(3) Install seal ring.

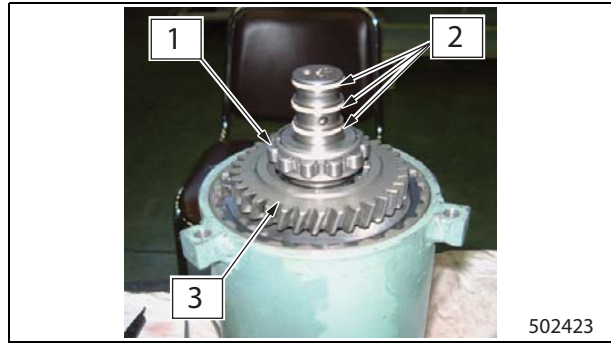

1. Bearing  
2. Seal ring

3. Forward gear

Part name	Part number	Qty
Seal ring	91B24-00500	3

## 5.6 Reverse Side Input Shaft Gear Assembly, Assembling

Note: Reassemble in the same manner as forward side.  
Follow the instructions for forward side carefully.

### Reverse clutch piston, Installing

Same as forward side.

### Reverse side friction plates and mating plates, Installing

Same as forward side.

### Reverse clutch piston movement, Checking

Same as forward side.

### Reverse gear assembly, Installing

Same as forward side.

### Reverse side input spacer and bearing, Installing

Same as forward side.

- (2) Mount transmission housing on the stand kit (special tool).
- (3) From the torque converter mounting side, tighten transmission housing bolts (3 places) to the specified torque.

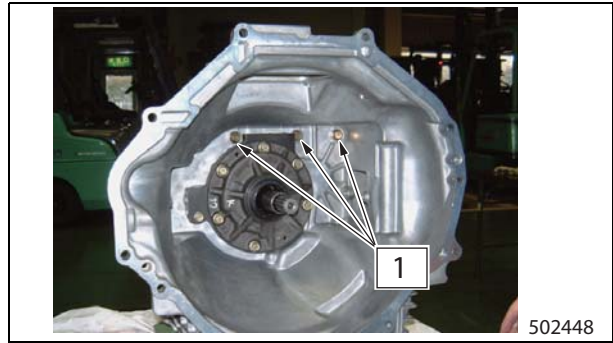

1. Bolt

Special tool	Part number
Stand kit	91A68-00020

Ref.	Tightening torque
1	39.2 ± 3.9 N·m (4.00 ± 0.39 kgf·m) [28.912 ± 2.87 lbf·ft]

### 5.10 Servo Case Assembly, Installing

- (1) Install O-rings.

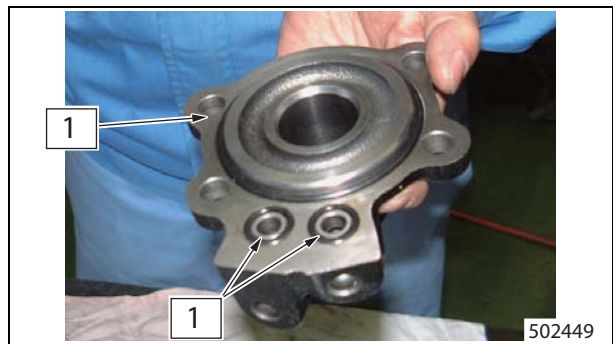

1. O-ring

- (2) Apply oil to the seal ring of input shaft assembly. Install the servo case assembly and tighten to the specified torque.

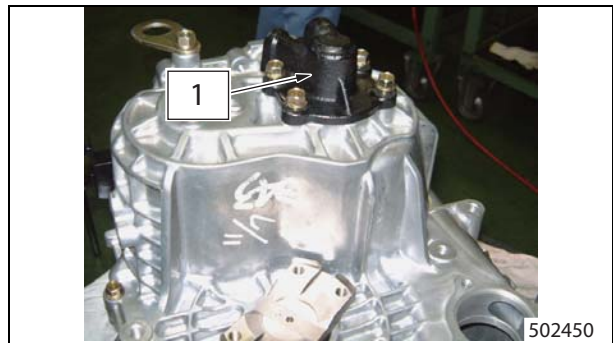

1. Servo case assembly

Item	Tightening torque
Servo case assembly	39.2 ± 3.9 N·m (4.00 ± 0.39 kgf·m) [28.912 ± 2.87 lbf·ft]

- (3) Insert the output flange and make sure it rotates smoothly by hand.

**Regulator valve, Removing**

- (1) Remove inner and outer main relief springs.
- (2) Remove the regulator valve together with slug.

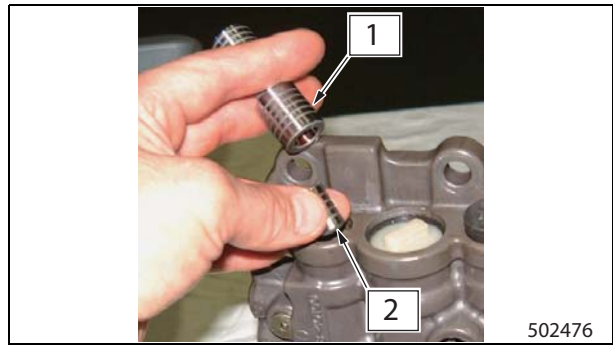

1. Regulator valve                      2. Slug

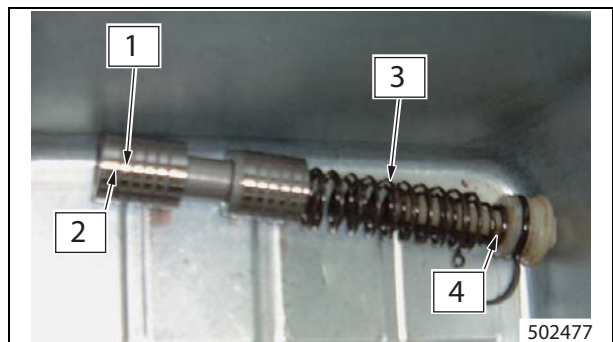

1. Regulator valve                      3. Main relief outer spring  
2. Slug                                      4. Main relief inner spring

**6.6 Accumulator Valve Section, Disassembling**

**Accumulator spring seat, Removing**

- (1) Remove the snapping from accumulator spring seat.
- Note: When removing the snapping, slowly remove the snapping by pressing it against the accumulator spring seat. Otherwise the accumulator spring seat may pop out.

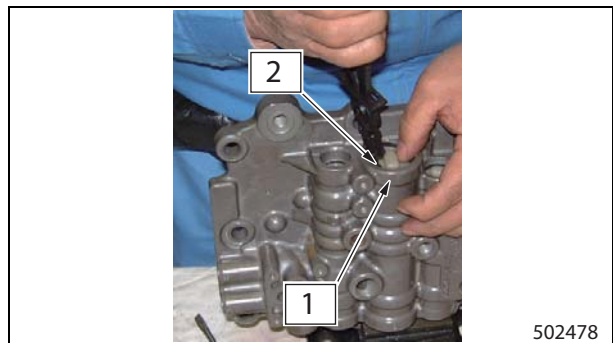

1. Accumulator valve section                      2. Snapping

- (2) Remove the accumulator spring seat together with O-ring.

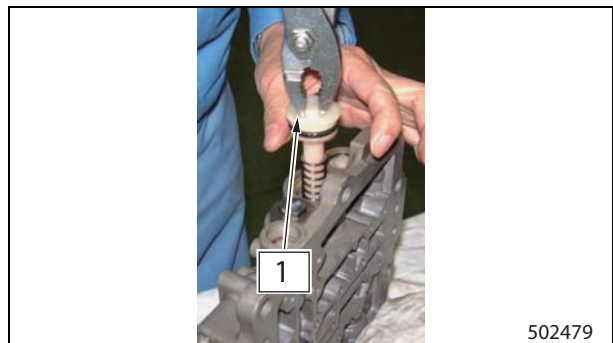

1. Accumulator spring seat

## 7.7 Regulator Valve Section, Assembling

### Regulator Valve Section, Assembling

- (1) Apply oil to slug and install slug on regulator valve.
- (2) Install the regulator valve with slug to the regulator valve section.

Note: When installing regulator valve, orient regulator valve so that the side to which slug is fitted faces to the inching lever side.

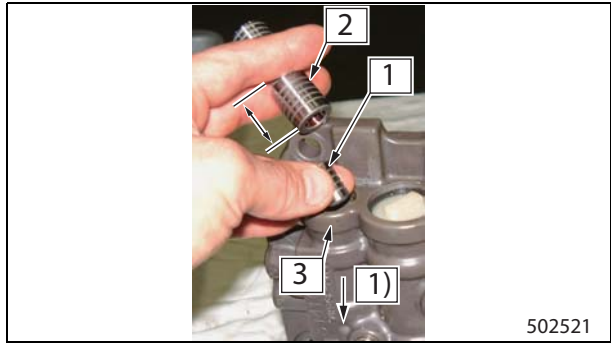

1. Slug
  2. Regulator valve
  3. Regulator valve section
- 1) Inching lever side

### Main spring seat, Installing

- (1) Insert inner and outer main relief springs to regulator valve section.
- (2) Install O-ring on main spring seat and apply a thin coat of grease to O-ring.
- (3) Insert main spring seat on regulator valve section.

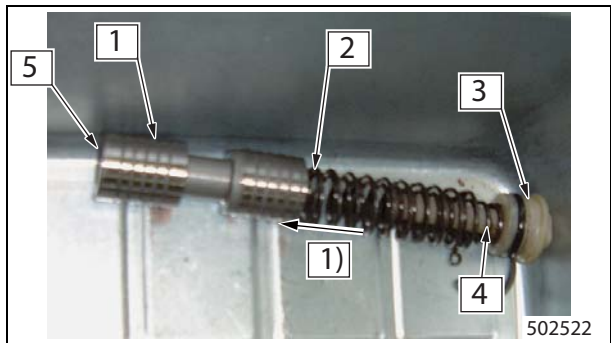

1. Regulator valve
  2. Main relief outer spring
  3. Main spring seat
  4. Main relief inner spring
  5. Slug
- 1) Inching lever mounting direction

Note: Do not reuse main spring seats and O-rings. Always install new ones.

- (4) While holding down accumulator spring seat, install snapping using the installer (special tool).

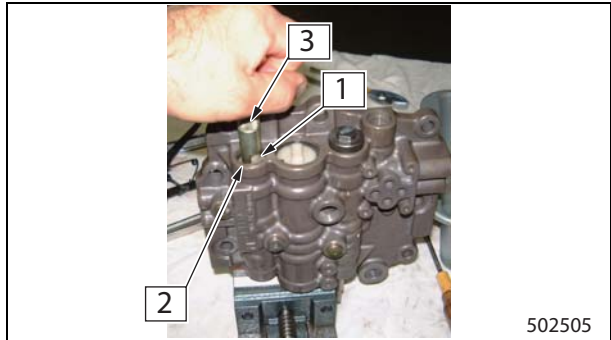

1. Main spring seat
2. Regulator valve section
3. Special tool (Installer)

Special tool	Part number
Installer	91A68-03100

### 8.3 Inching Cable, Adjusting

#### Preparation

- (1) Block rear wheels and raise front wheels in the same manner as instructed in the above oil pressure measurement. Connect an oil pressure gauge to the oil pressure tap.
- (2) Make sure that the projection of the inching rod is 33.5 to 34.5 mm (1.319 to 1.358 in.).
- (3) Insert 0.5 mm (0.020 in.) thick shim between inching pedal stopper and inching pedal stopper bolt so that inching cable play is 0 mm (0.00 in.).
- (4) Tighten the inching cable locknut.
- (5) 0.5 mm (0.020 in.) shim should be removed at this point.
- (6) Make sure that inching pedal stopper has contact with stopper bolt.
- (7) Lightly press the inching pedal by hand, and make sure that clearance between inching pedal stopper and stopper bolt is 0.4 to 1.1 mm (0.016 to 0.043 in.) when the inching lever is just about to move.

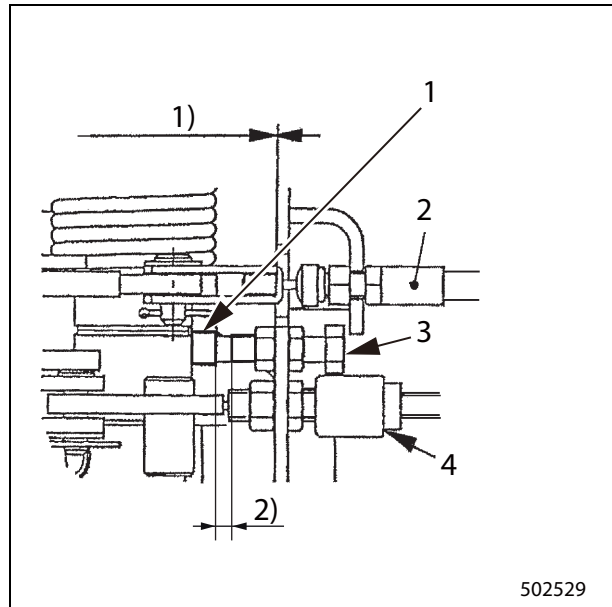

502529

- |                          |  |
|--------------------------|--|
| 1. Inching pedal stopper | 1) Inching cable play                                |
| 2. Inching cable         | 2) Clearance (0.4 to 1.1 mm<br>(0.016 to 0.043 in.)) |
| 3. Stopper bolt          |  |
| 4. Stop light switch     |  |

### ⚠ CAUTION

If the play of inching cable is not properly adjusted, the following failure will occur.

- When the play is less than 0.4 mm (0.016 in.):  
Even if the inching pedal is not pressed, or when the operator has put his/her foot on the inching pedal lightly, the clutch oil pressure decreases, and the clutch slips. This results in the premature wear or burnout of friction plates.
- When the play is greater than 1.1 mm (0.043 in.):  
Even if the inching pedal is fully pressed, the clutch oil pressure will not decrease enough to disengage the clutch completely. This results in premature wear or burnout of friction plates.

#### Adjusting procedure

- (1) Run the engine at idle speed to raise the temperature of the transmission oil.
- (2) Shift the direction lever into FORWARD position.
- (3) Gradually press the inching pedal to retract the inching rod. Make sure that oil pressure becomes 0 (zero) when the projection of the inching rod is 26.9 mm (1.059 in.) or less.

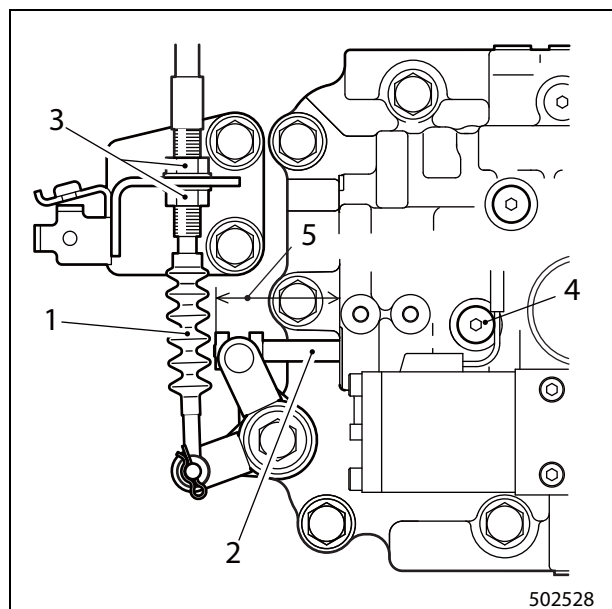

502528

- |                  |                            |
|------------------|----------------------------|
| 1. Inching cable | 4. Clutch oil pressure tap |
| 2. Inching rod   | 5. Inching rod projection  |
| 3. Locknut       |                            |

## Chapter 9 FRONT AXLE AND REDUCTION DIFFERENTIAL

### 1. Specifications

Item			Specification
Power transmission system	Reduction gear	Gear type	Hypoid gear
		Reduction ratio	5.667
	Final drive	Gear type	Planetary gear
		Reduction ratio	4.125
	Differential gear	Case type	Banjo
		Gear type and quantity	Large
Small			Straight bevel gear x 2
Traveling system	Front axle type		Full-floating, tubular
	Suspension system	Front wheel	Rigid axle

## 8. Front Axle, Inspection and Repair After Disassembly

### Axle shaft

- Looseness of mating splines:  
Mount the differential bevel gear on the splined end of the shaft and set a dial indicator as shown. Rotate the bevel gear in the direction shown and read the free play (looseness of mating splines).

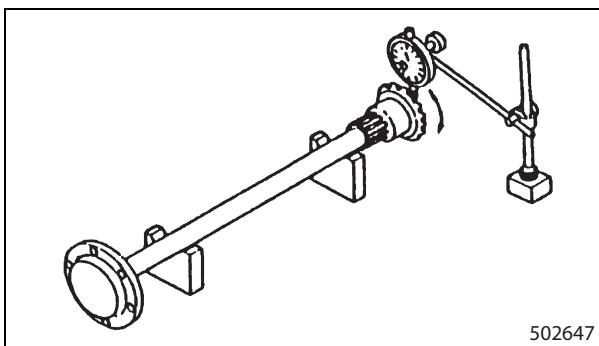

Item	Standard	Limit
Looseness of mating splines	0.15 mm (0.0059 in.)	0.5 mm (0.020 in.)

### Axle shaft deflection measurements

- Measure deflection with a dial gauge positioned on the center of the axle shaft while rotating the shaft.

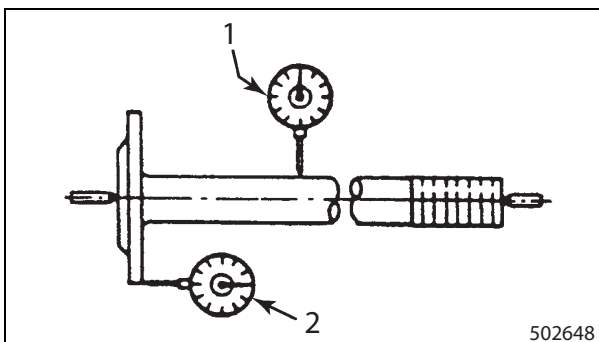

1. Axle shaft deflection measurements

2. Flange face runout measurements

Item	Standard	Limit
Deflection of axle shaft (1/2 of dial indicator reading)	0.5 mm (0.020 in.) or less	1.0 mm (0.039 in.)

- Set a dial indicator against the flange of the axle shaft as shown. Rotate the shaft and read the face runout of flange.

Item	Standard	Limit
Face runout of axle shaft flange	0.08 mm (0.0031 in.)	0.5 mm (0.020 in.)

### Axle housing

- Check the surfaces of axle housing in contact with the mast bearing for damage.
- Check the entire axle housing for distortion, dents and other defects. Pay particular attention to the welds to see if any of the welds are cracked enough to require repair.

### Miscellaneous

- Check the outer surface of oil seal and retainer for wear or damage.
- Check the outer and inner oil seals for wear or damage.

**Preload adjustment**

- While rotating reduction gear by hand, tap its back side with a soft-head mallet for snug assembling.
- Hook a spring scale on the bolt 2, and pull it in the tangential direction to read the force when the gear starts rotating (preload for the bearing).
- Adjust preload by tightening or loosening the right and left adjusting screws 1.

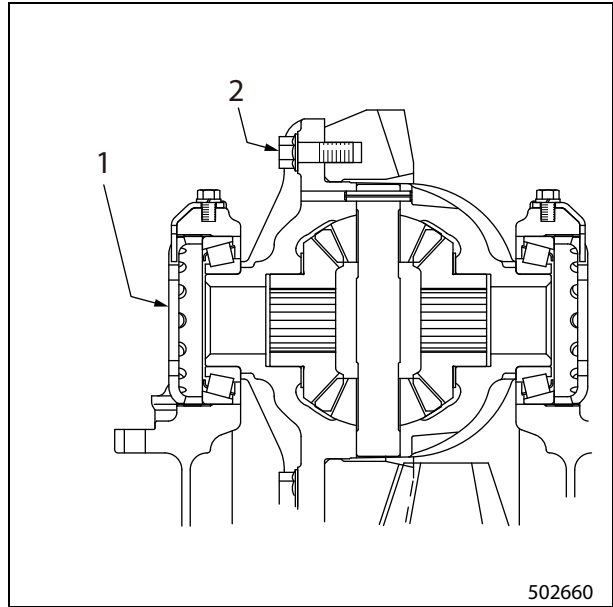

1. Adjusting screw

2. Bolt

502660

Item		Standard
Preload	1, 2 ton classes	14.7 to 29.4 N (1.50 to 3.00 kgf) [3.305 to 6.609 lbf]
	3 ton class	12.8 to 24.5 N (1.31 to 2.50 kgf) [2.878 to 5.508 lbf]

**Differential cases, Removing**

Preload can be determined in the above steps. Make a matchmark across adjusting screw and bearing cap, and remove differential cases from the carrier.

**Shimming reduction pinion**

Refer to 9-25 "Reduction Gear Tooth Contact".

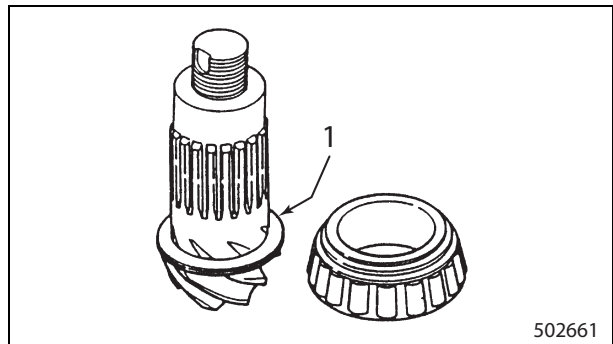

1. Shim

502661

### 1.4 Left Side Kingpin Section, Main Components

Detail of left side kingpin section

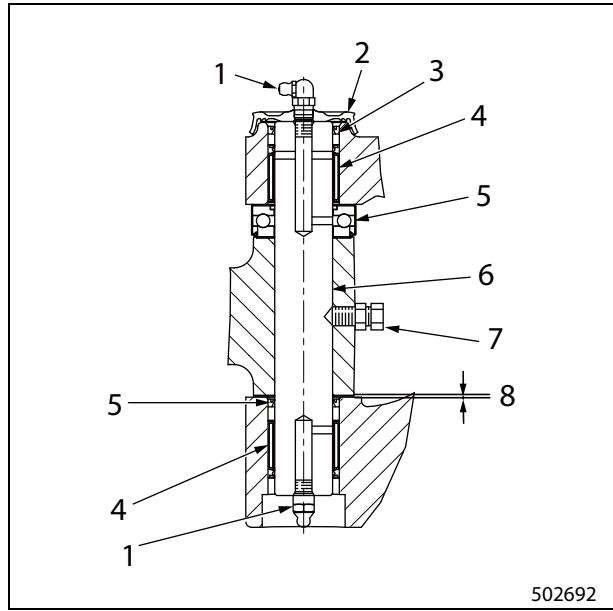

- |                   |                                    |
|-------------------|------------------------------------|
| 1. Grease nipple  | 6. Left side kingpin               |
| 2. Kingpin cover  | 7. Stopper bolt, Locknut           |
| 3. Dust seal      | 8. Shim (for clearance adjustment) |
| 4. Needle bearing |                                    |
| 5. Thrust bearing |                                    |

### 1.5 Right Side Kingpin Section, Main Components

Detail of right side kingpin section

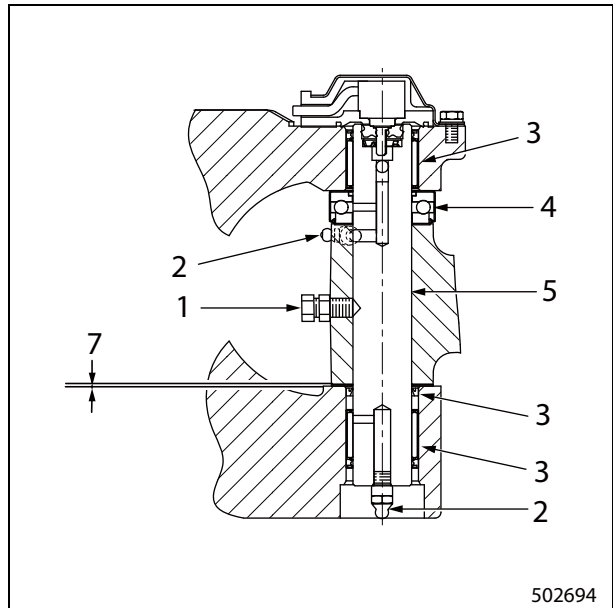

- |                          |                                     |
|--------------------------|-------------------------------------|
| 1. Stopper bolt, Locknut | 5. Right side kingpin (with sensor) |
| 2. Grease nipple         | 6. Dust seal                        |
| 3. Needle bearing        | 7. Shim (for clearance adjustment)  |
| 4. Thrust bearing        |                                     |

## 12. Knuckle Section (Kingpin), Assembling

### 12.1 Suggestions for Assembly

For assembly, follow the disassembly sequence in reverse and observe the instructions below.:

- (1) Reassemble the kingpin from the lower side toward the upper side.  
Note: If assembled the other way around, shims may be damaged.
- (2) Orient thrust bearing in the direction shown in the figure. Obtain 0.2 mm (0.008 in.) clearance in the axial direction using shims.
- (3) To install dust seal and needle bearing, use a driving tool.
- (4) Orient tabs of plate (3 places) upward. Align the notch to the locating spring pin, which protruding from the kingpin. Install snugly to the full depth.
- (5) After assembly, lubricate sufficiently. Apply grease until it overflows from the boundary between axle and knuckle.
- (6) Dimensions after assembly are shown below.

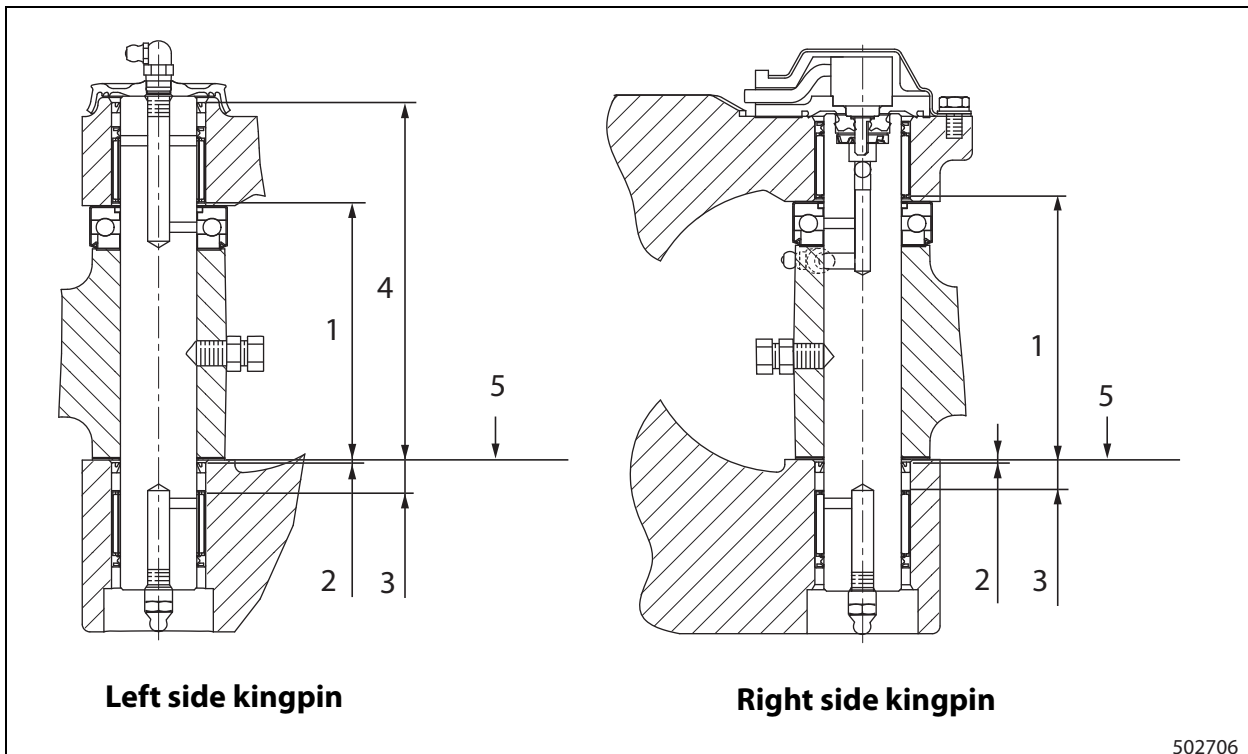

502706

- |   |   |
|---|---|
| 1. Bearing end face (101 mm(3.976 in.)) | 4. Seal end face (140.5 mm(5.5315 in.)) |
| 2. Seal end face (1 mm(0.039 in.))      | 5. Base level                           |
| 3. Bearing end face (12 mm(0.472 in.))  |   |

### 6.3 Suggestions for Disassembly

#### Return spring, Removing

Remove return spring from shoe guide plate using special tool.

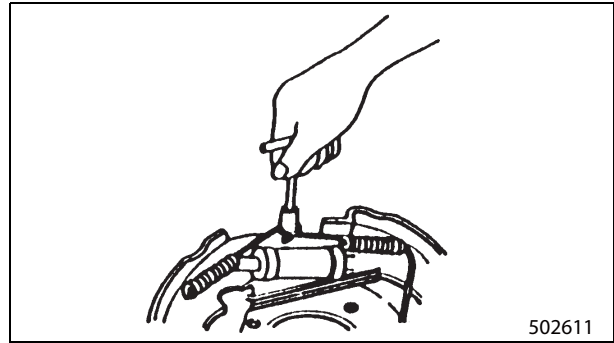

Special tool	Part number
Spring remover	64309-15411

#### Hold-down spring, Removing

Remove shoe hold-down spring from backing plate using special tool.

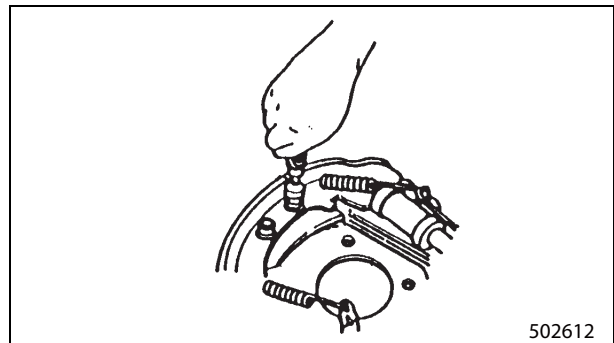

Special tool	Part number
Spring retainer	64309-15412

### 12.4 Brake Pedal, Adjusting

- (1) Using the stop bolt, adjust the installed height A of the brake pedal (from the floor to the top of the pedal pad). Lock the stop bolt after adjustment.

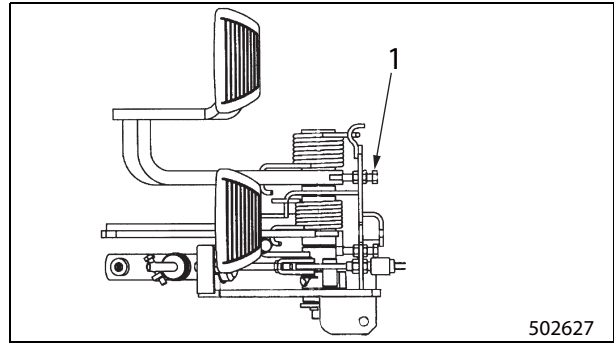

1. Stopper bolt

- (2) Adjust the clearance between master cylinder push rod and piston to 1.0 mm (0.039 in.). To do this, turn the push rod clockwise. When it comes into contact with piston, turn it back counterclockwise for approx. 0.8 turn, then secure the clevis with nut.
- (3) Check pedal play C.

Note:

- Ensure that the clevis pin connecting the brake pedal to push rod is securely fitted.
- Ensure that the snap pin is securely fitted.
- Ensure that the brake pedal operates smoothly without binding or other problems.

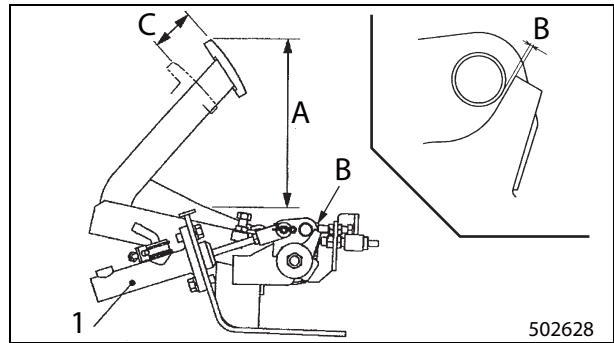

1. Master cylinder

Item		1 ton class	2, 3 ton classes
Pedal height A from floor		191.6 mm (7.543 in.)	191.6 mm (7.543 in.)
Clearance B		0.2 to 1.0 mm (0.008 to 0.039 in.)	0.2 to 0.8 mm (0.008 to 0.032 in.)
Push rod-to-piston clearance	Powershift truck	1 mm (0.04 in.)	1 mm (0.04 in.)
	Manual truck	1 mm (0.04 in.)	1 mm (0.04 in.)
Pedal play C	Powershift truck	7 mm (0.28 in.)	7 mm (0.28 in.)
	Manual truck	7 mm (0.28 in.)	7 mm (0.28 in.)

It is important that the knob position of the steering wheel always remains constant at a given position during straight-ahead travel. As the steering system of this truck is fully hydraulic, a knob deviation occurs if a driving operation causes relief in the steering system. When this occurs, the knob deviation correction system immediately corrects the deviation.

The relationship between steering wheel angle and steering angle in a normal condition is stored in the VCM controller. On the other hand, the knob position of steering wheel and steering angle are constantly monitored by sensors, and detected data is sent to VCM controller for comparison with the normal values. When the magnitude of knob deviation exceeds the specified value, the controller actuates the control valve (with solenoid) to open a bypass passage so that knob deviation is correct.

In a normal condition, the control valve 6 is closed. The whole amount of pressure oil from steering valve 7 flows to steering cylinder 5.

When a knob deviation occurs, VCM controller sends an electrical current to the control valve solenoid, thereby opening the steering valve. Then a partial amount of pressure oil on high-pressure side flows into the low-pressure side (return passage) through the orifice of control valve. As a result, oil supply to steering cylinder will be reduced by that much.

This results in a phenomenon that the steering angle does not change in proportion to the steering wheel movement.

For example, even if steering wheel large movement occurs due to slippage between steering wheel and steering valve, the steering angle does not change that much.

This system corrects the relationship between steering angle and the knob position by applying such phenomenon. The deviations are corrected during the steering wheel is being turned to the right or left.

Correction is made only when the steering wheel is turned in such a direction as makes an approach to the target (correct knob position) within 180 degrees of the steering angle from the current knob position.

Note that the knob deviations are not corrected under the following conditions:

- When steering angle is too large
- When steering wheel is being turned very slowly

Note: A knob deviation, if it occurs by maintenance, etc., can automatically be corrected by starting the engine and turning the steering wheel from the extreme left to the extreme right.

For electrical equipment including sensors, refer to CHAPTER "ELECTRIC SYSTEM".

**Control spool and control sleeve, Disassembling**

Push the spool in sleeve slightly forward and remove the centering springs.

While rotating control spool slowly, remove the spool from the sleeve by pulling it toward the rear end of sleeve.

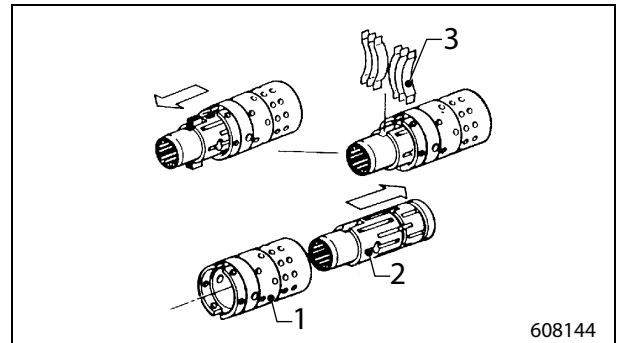

1. Control sleeve                      3. Centering spring  
2. Control spool

**⚠ CAUTION**

Before disassembling put a matchmark on the control spool and control sleeve.

**11. Inspection After Disassembly**

- (1) Inspect sliding faces between sleeve and housing and between sleeve and spool.
  - Inspect sliding movement in the sub-assembly condition.
  - If any unusual sliding movement is detected, inspect sliding surfaces.
- If any defect such as wear, scratches, burrs, or rust are found, replace the entire unit with a new one.

Hydraulic lines diagram for trucks with wet single-disc clutch

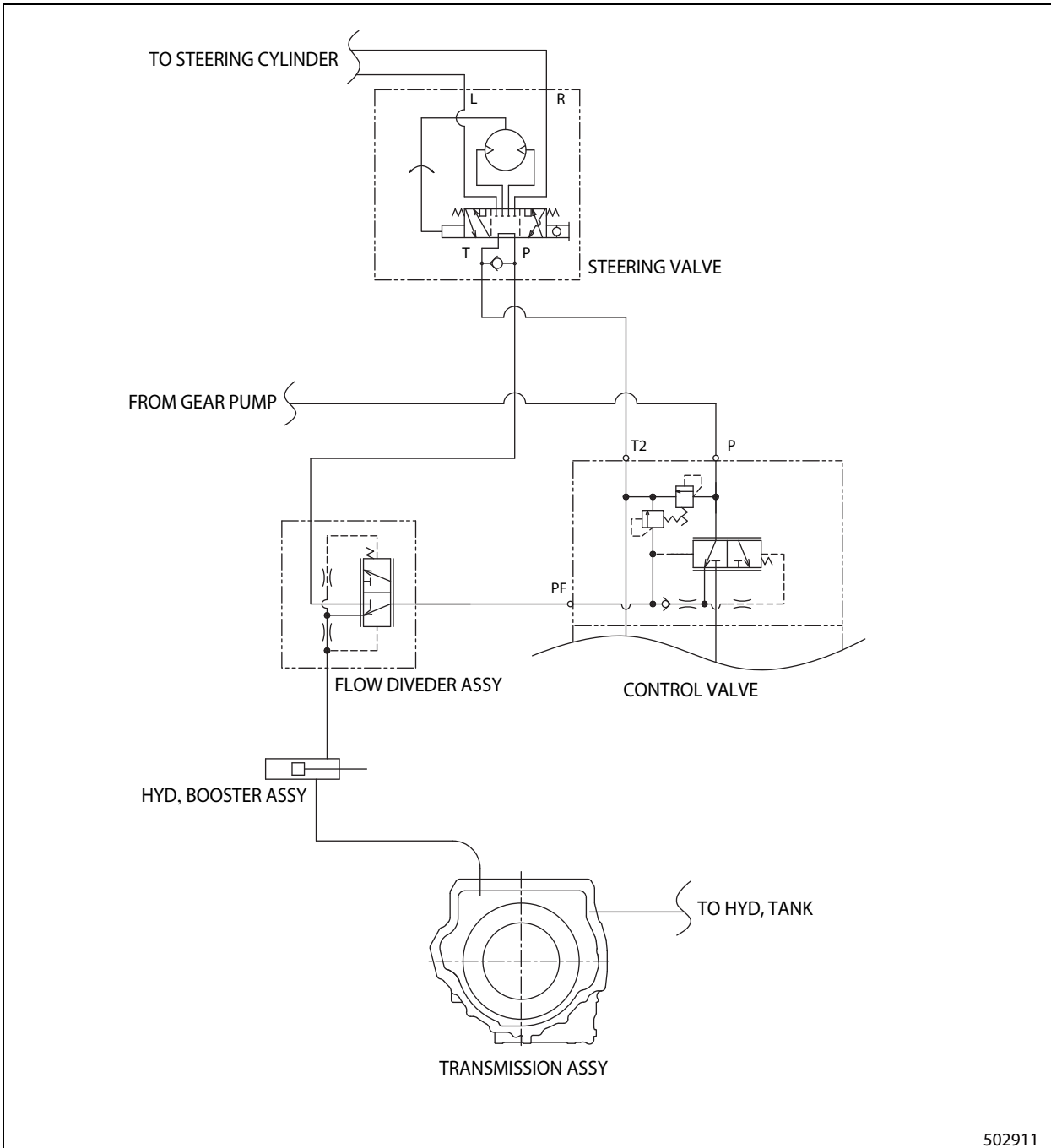

502911

Note: For wet clutch components, structure and maintenance procedure, refer to CHAPTER "CLUTCHES".

**Movement during piston descent**

The figure on the right shows the movement of the cushion spool 6 when the piston descends. (To the right of the figure is the bottom of the cylinder.)

- (1) This figure shows the position of the cushion spool 6 before it contacts the cylinder bottom. The cushion spool 6 is extended by the spring 8.

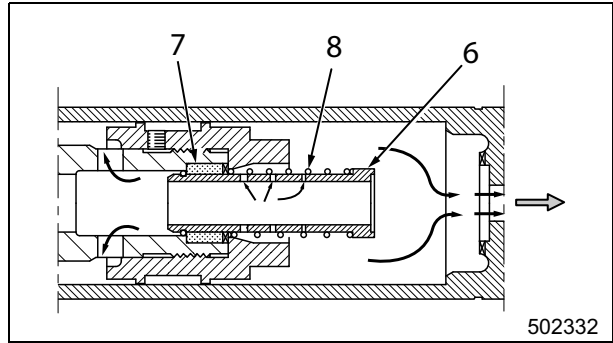

- (2) This figure shows a condition in which cushion spool 6 is in contact with the cylinder bottom and slightly moves into check valve 7. The check valve moves to the left, blocking area 1). Oil 2) trapped below the piston is discharged through holes (two rows on the right) of the cushion spool 6. For check valve shape, see the figure on the next page.

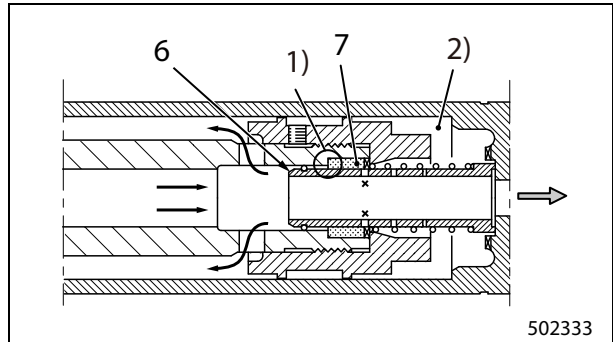

- (3) As the piston descends further, cushion spool 6 moves into the check valve further. As a result, the number of escape holes are decreased and the discharge of trapped oil 2) is restricted. The descending speed of the piston becomes slower, thereby collision is avoided.

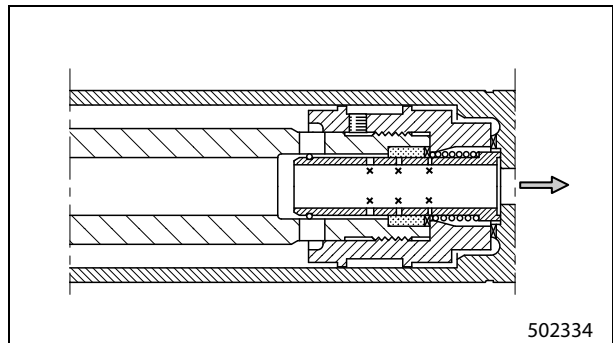

## 9.4 Removing Second Lift Cylinders

- (1) Disconnect hoses from the second lift cylinders.
- (2) Remove the set bolts located at the top of the second lift cylinders. Attach a wire rope either to the middle or inner mast, and raise the mast by approximately 55cm (2.2 in.).

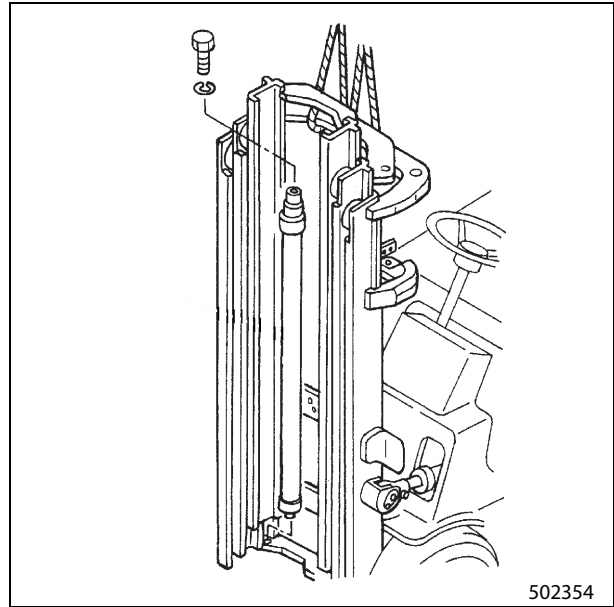

- (3) Place wood blocks of the same height under the both sides of the inner mast (for duplex mast) or the middle mast (for triplex mast).

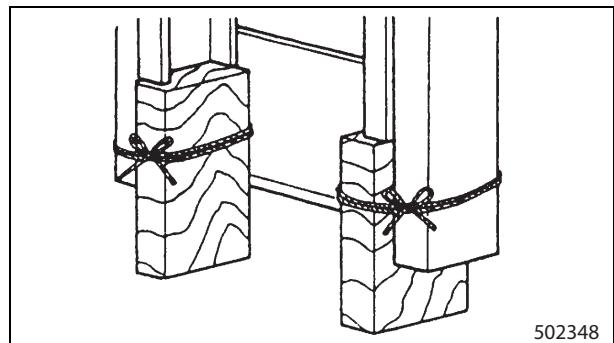

- (4) Attach a wire rope to the second lift cylinder from behind the mast, and support the cylinder with a hoist. Remove the clamp bolts from the cylinder and separate the second lift cylinder from the mast. Then slowly lift the cylinder. When lifting the lift cylinder, do not lift the lift cylinder straight up because the lift cylinder will hit against the mast cross member. Tilt the lift cylinder to clear the cross member while removing. Keep hands away from any part of the lift cylinder or mast to prevent a risk of injury.

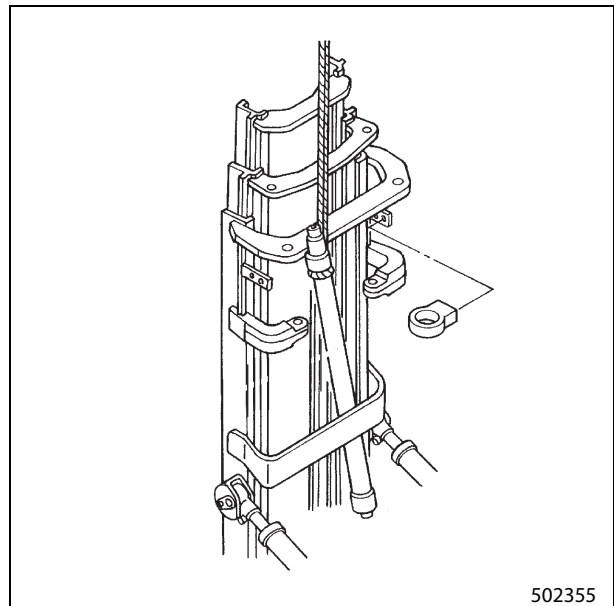

## 20. Removing tilt cylinders

### 20.1 Preparation

- (1) Lower the forks to the ground, and tilt the mast fully forward.
- (2) Attach a lifting sling to the cross member of the outer mast, and support the mast with a hoist.

### 20.2 Removal Sequence

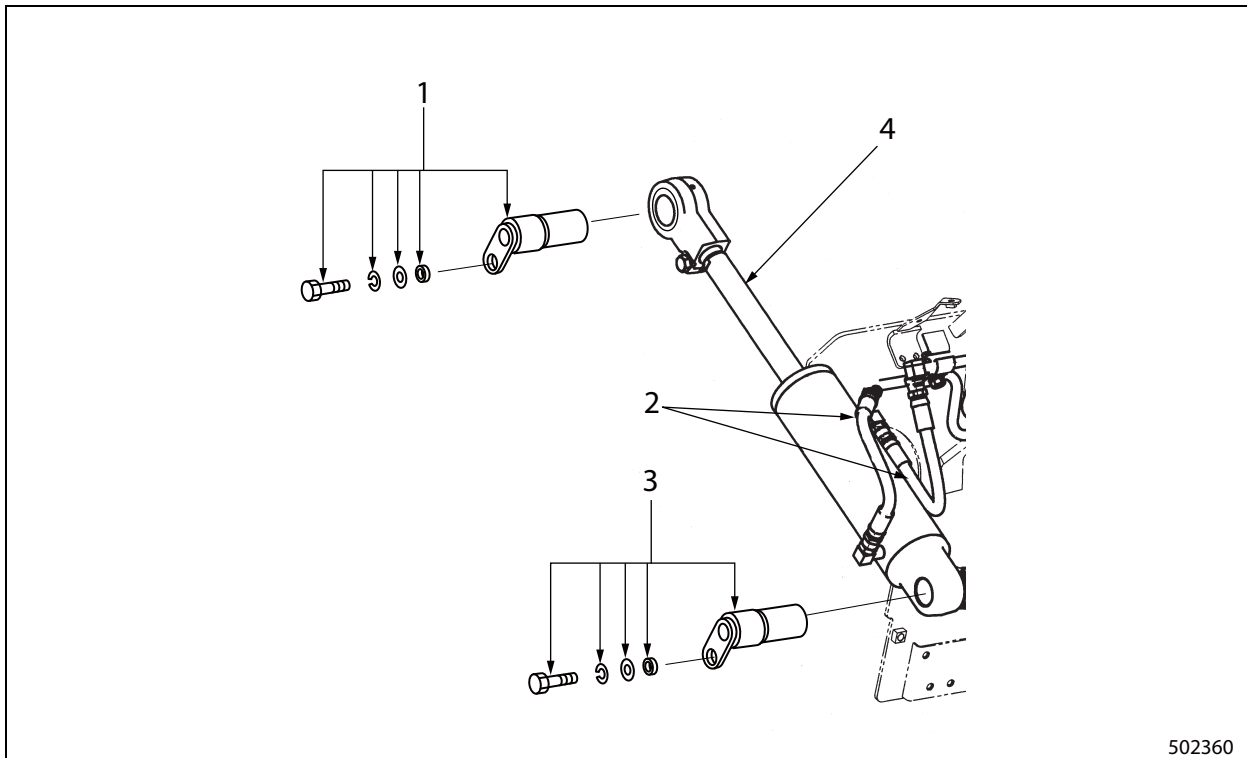

502360

- |                                  |                      |
|----------------------------------|----------------------|
| 1. Tilt cylinder pin             | 3. Tilt cylinder pin |
| 2. Hoses (2 places per cylinder) | 4. Tilt cylinder     |

### 20.3 Suggestions for Removal

#### Retracting piston rod

Remove tilt cylinder pin 1, start the engine, and fully retract the piston rod. Turn the engine OFF.

#### Removing hoses

Disconnect hoses 2 from the connectors on cylinder side. Prepare an empty can to catch oil that will flow out. Attach caps to the cylinder nipples to protect the threads from damage and to prevent oil from flowing out through them during cylinder removal.

#### Removing tilt cylinders

Remove tilt cylinder pin 3, and remove the cylinder.

## 21. Tilt Cylinders, Installing

For installation, follow the removal sequence in reverse.

### 21.1 Suggestions for Installation

After installing tilt cylinders, check balance of the mast tilt angle. Adjust as required. For adjustment, refer to CHAPTER "MAST AND FORKS".

### 30.2 Gear Pump

Condition	Possible cause	Actions
Cylinders move too slow	Gear pump does not suck oil	Check pump and piping, and repair or replace as required
	Oil leaks from hydraulic line	Check oil level and condition, add or change
	Gear pump internal leakage	Replace pump
Pump is too noisy	Poor pumping of oil	Add oil by referring to CHAPTER "SERVICE DATA"
	Cavitation	Check suction pipe for any flat portion or loose connection. Retighten or replace if necessary
		Check shaft oil seal for airtightness, replace pump
	Check pump body for any outside interference. Repair	
Pump case, drive gear or pump port flange is damaged	Pressure is higher than rated	Replace pump. (Check if pressure control valve had been working at rated valve.)
	Distortion or damage due to external force	Replace pump
		Check if return line has been blocked or excessively restricted
	Check to see if pipe connections have been externally strained or stressed	
Oil leaks from pump	Oil leaks from oil seal	Replace shaft seal
	Oil leaks through sliding surfaces of drive shaft	Replace the pump assembly
	Bolts that secure the pump are loosened	Retighten. Replace as required
	Seal inside pump is deteriorated	Replace gasket

### 30.3 Control Valve

Condition	Possible cause	Actions
Slow or no motions of lift and tilt cylinders.	Valve opening pressure setting is too low	Adjust pressure
	Relief valve piston does not move smoothly	Wash piston and check to see if it moves smoothly, or replace relief valve assembly
	Outer O-ring on relief valve body is damaged	Replace O-ring
	Spool stroke is not enough due to control lever looseness	Adjustment
	Oil temperature rises abnormally	Check if spool is not in proper position, and repair or replace as required
Lift/tilt drift (descent or forward tilt)	Control valve spool internal leaks	Replace leaking block assembly
Oil leaks	Oil leaks at spool ring cap	Replace O-ring, also check spool for scratches. If scratches are found, repair or replace block assembly
	Plug loose	Retighten plug
	O-ring damaged	Replace O-ring

Valve 8 is an orifice installed at oil inflow/outflow passages for damper chamber 5. This orifice preferentially delivers PF flow in a stable condition (no occurrence of surging) by controlling the moving speed of valve spool 1.

When increasing excess flow (EF flow), pressure oil in port P will flow into damper chamber 5. As this passage is the orifice on the edge of valve 8 only, the movement of valve spool 1 is slow.

When PF flow is insufficient, it is necessary to increase PF flow by quickly restricting EF restricted area. For this, oil in damper chamber 5 has to be discharged as quickly as possible. As the orifice on the circumference as well as the orifice on the valve edge is in the passage at this time, the spool can move to the left quickly.

This action can prevent a kickback phenomenon caused on the steering wheel when pressure of PF flow is decreased.

Ball check 3 prevents backflow of PF flow. This is a preventive measure for a kickback phenomenon.

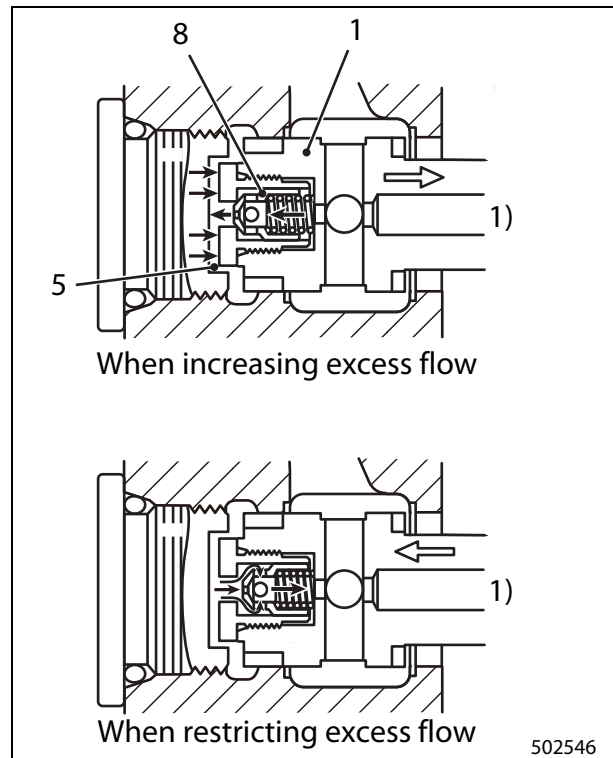

502546

1) Valve spool movement

**Main relief valve**

This valve is a relief valve with a pilot valve. When pressure in the P port reaches the set value, poppet valve 1 is pushed to the left (in the figure), leaving the seat. Pilot oil in the spring chamber flows in the drain passage. Then, dump valve 2 moves to the left, releasing a part or all of main flow to the low-pressure passage.

This is a safety valve to protect the system.

To adjust, turn adjusting screw 3 to change preload of spring 4.

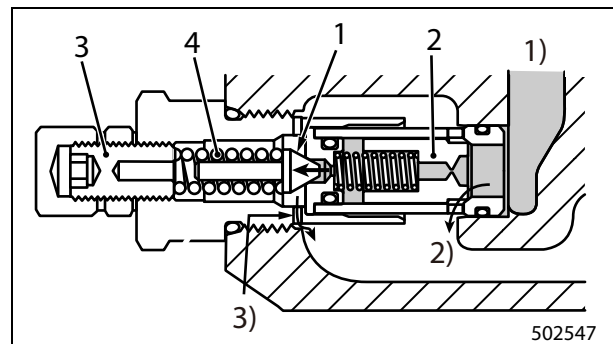

502547

1) High-pressure passage 3) Pilot oil drain passage  
2) Low-pressure passage

**Steering system relief valve (PF relief valve)**

This is a direct-acting relieve valve.

The valve acts when the steering wheel is fully turned. This is a safety valve to protect the system. To adjust, turn the adjusting screw to change preload of the spring.

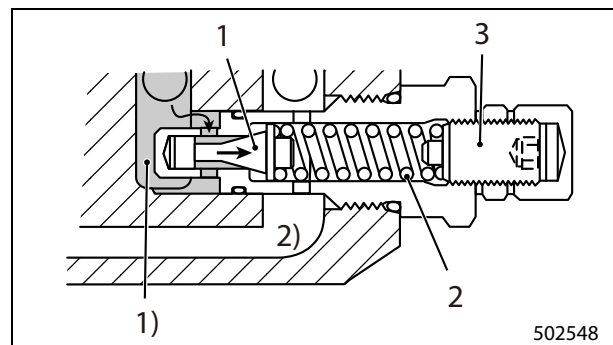

502548

1. Valve 1) PF flow passage  
2. Spring 2) Low-pressure passage  
3. Pressure adjusting screw

## 37. Control Valve - Tilt Valve, Disassembling

### 37.1 Disassembly Sequence

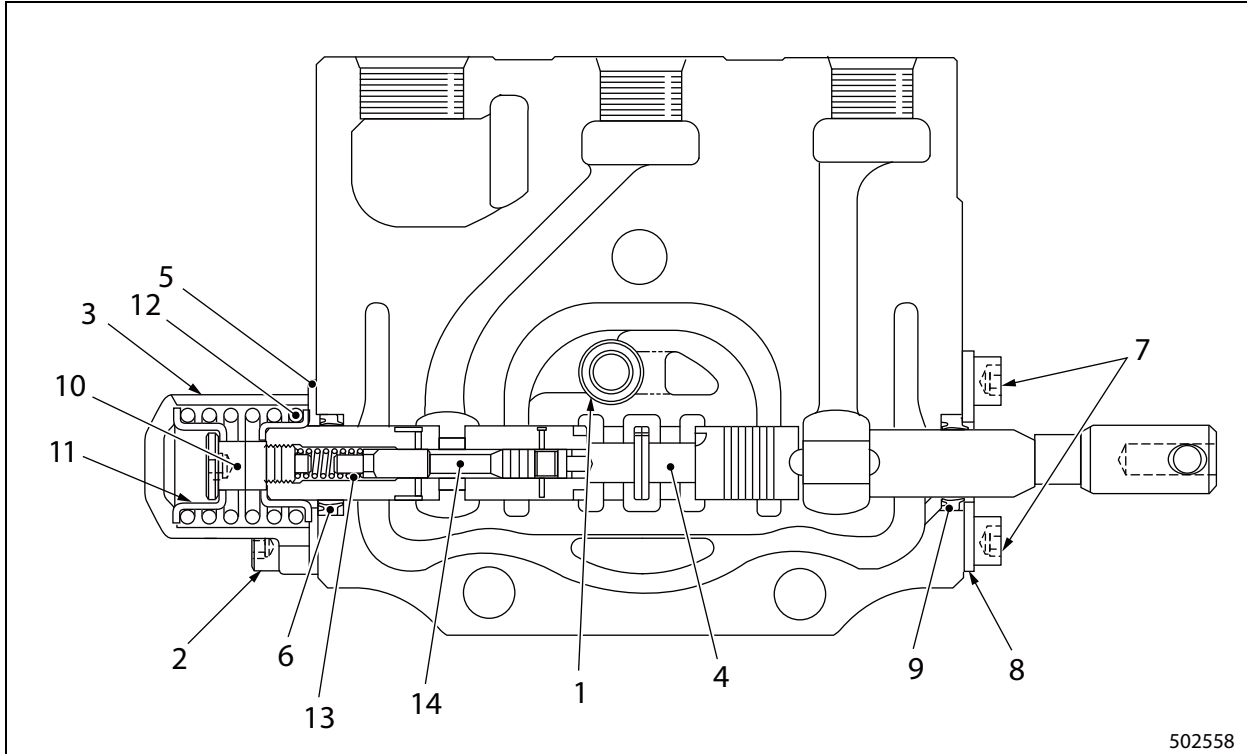

- |                        |                     |
|------------------------|---------------------|
| 1. Check valve, Spring | 8. Plate            |
| 2. Bolt                | 9. Seal             |
| 3. Cap                 | 10. Cap screw       |
| 4. Spool sub-assembly  | 11. Spring retainer |
| 5. Plate               | 12. Spring          |
| 6. Seal                | 13. Spring          |
| 7. Bolt                | 14. Tilt lock valve |

Note: Spool sub-assembly components: Parts 10 thru 14

### 37.2 Suggestions for Disassembly

- (1) Remove spool 4 from the body without removing spring 12 and cap screw 10.
- (2) When removing cap screw 10, hold the spool in a vise with soft jaws (hard wooden plate or plastic plate) and remove the cap screw using a hexagon wrench. Be careful because the spring may jump out. Also remove the tilt lock valve.

**CAUTION**

- Do not touch any levers except the tilt lever while the engine is running.
- Never loosen the tilt socket bolts except when disassembling the tilt cylinder.

**Removing mast support bearing cap**

- (1) Make a matchmark on each cap.
- (2) Remove cap mounting bolts from the mast and disconnect the mast assembly from the lift truck by hoisting. Lay the mast assembly horizontally on level ground with the lift bracket side facing up.

Note: Lay the mast assembly in a space large enough for disassembly work.

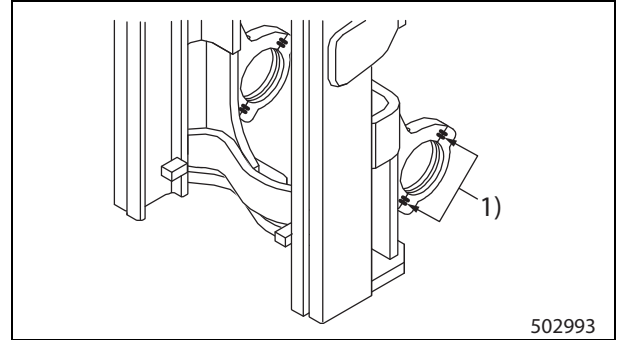

1) Matchmark

**1.5 Suggestions for Installing of Mast and Lift Bracket Assembly**

For installation, follow the removal sequence in reverse and observe the instructions below.

**Mast support**

- (1) Apply a thick coat of grease to the inner surface of the caps and the mast support bushings.
- (2) For 1 ton class:  
When installing caps, orient the wider chamfered side 3 toward the center of the chassis. (For fusion cutting processed products)

Note: For casting products, there is no difference between inner and outer sides, however, install them in the same orientation as they were removed.

- (3) For 2, 3 ton classes:  
Chamfering is the same both on the right and left sides. Install the mast supports in the same direction as they were removed.
- (4) For easier greasing, place wood blocks under the mast so that the mast is off the ground.

**Adjusting chain tension**

For chain adjustment, refer to 14-19 "Inspection and Adjustment".

**Bleeding lift cylinders**

Move the lift bracket up and down for several times to bleed air trapped in the piston end of the lift cylinder.  
After the proper operation of the lift truck is confirmed, check the oil level in the hydraulic tank.

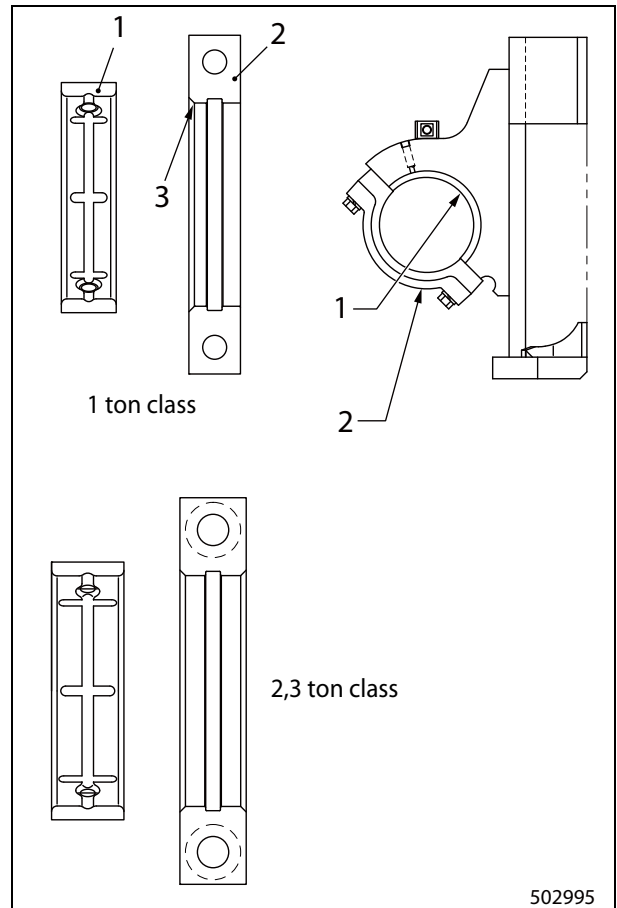

1. Bushing  
2. Cap  
3. Chamfer

### 1.15 Installing Hydraulic Lines

**General precautions**

- Use care not to let abrasive dust or dirt to enter the hydraulic system during installation.
- Apply a coat of oil to O-rings before installation.
- Elbow connector 6 should be assembled with straight threads and O-ring seal observing the procedure 14-17 "Installation of a fitting with straight threads and O-ring seal".

**Tightening torque**

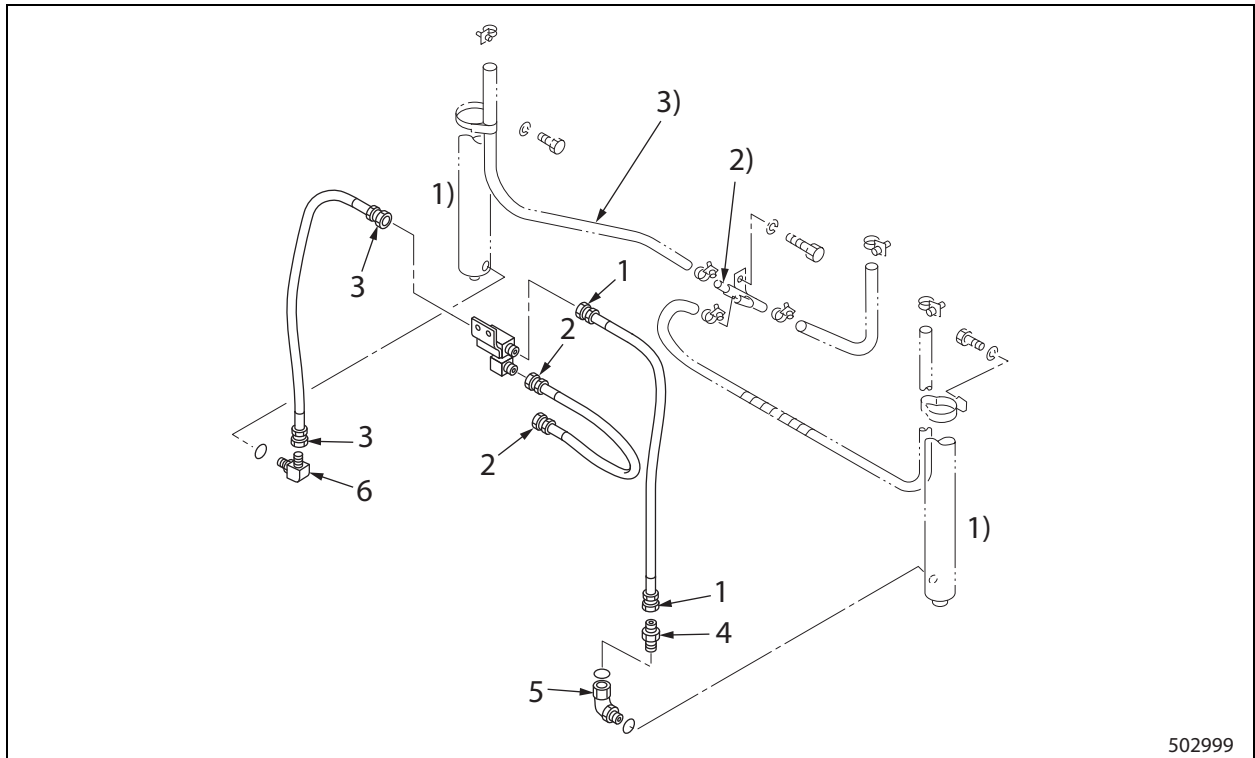

- 1) Lift cylinder
- 2) Return line connector
- 3) Return hose (equipped on masts having 3.5 mm or above lifting height.)

Item		Specified value	
		1,2 ton classes	3 ton class
1	Nut	49.0 ± 4.9 N·m (5.00 ± 0.49 kgf·m) [36.141 ± 3.61 lbf·ft]	58.8 ± 5.9 N·m (6.00 ± 0.60 kgf·m) [43.369 ± 4.35 lbf·ft]
2	Nut	58.8 ± 5.9 N·m (6.00 ± 0.60 kgf·m) [43.369 ± 4.35 lbf·ft]	
3	Nut	49.0 ± 4.9 N·m (5.00 ± 0.49 kgf·m) [36.141 ± 3.61 lbf·ft]	
4	Nut	39.2 ± 3.9 N·m (4.00 ± 0.39 kgf·m) [28.912 ± 2.87 lbf·ft]	
5	Nut	39.2 ± 3.9 N·m (4.00 ± 0.39 kgf·m) [28.912 ± 2.87 lbf·ft]	
6	Nut	39.2 ± 3.9 N·m (4.00 ± 0.39 kgf·m) [28.912 ± 2.87 lbf·ft]	

**Measuring right-to-left clearance on outer mast main rollers**

- (1) Raise the mast to the maximum lift position.
- (2) Set a dial indicator on the outer mast with its contact point rested on the inner mast.
- (3) Using a claw bar, push the outer main roller against the inner mast's rolling surface. Then go over to the opposite side of the mast and set the dial indicator to zero.
- (4) Insert a claw bar between the outer mast and the inner mast on the dial indicator side, and push the inner mast to the opposite side.

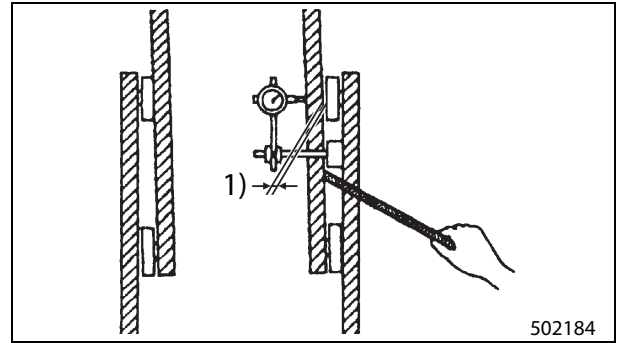

1) Clearance between main roller side face and mast

- (5) Measure the clearance between outer mast and inner mast main roller.
- (6) If clearance deviates from the specified value, adjust shim thickness. For adjustment, refer to 14-12 "Installing Mast Rollers (All Mast Models)".

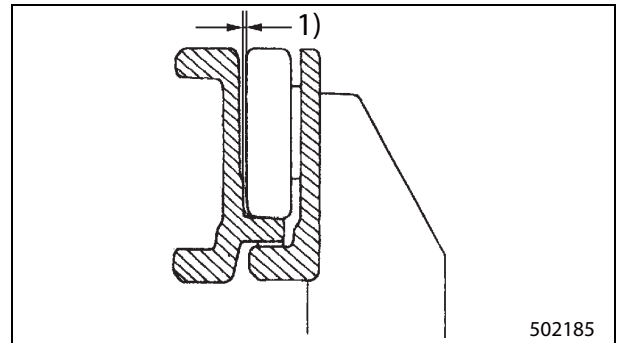

1) Clearance between main roller side face and mast

Ref.	Item	Standard
1)	Clearance between main roller side face and mast	0.1 to 0.5 mm (0.004 to 0.020 in.)

**1.23 Inspecting and Adjusting Mast Strip Clearance (All Mast Models)**

- (1) Measure the clearance with the clearance between the outer mast rollers and the inner mast rolling face adjusted to 0 mm (0.00 in.) at the maximum lift position.
- (2) If mast strip clearance deviates from the specified value, adjust shim thickness. For adjustment, refer to 14-13 "Adjusting clearance between mast and mast strip".

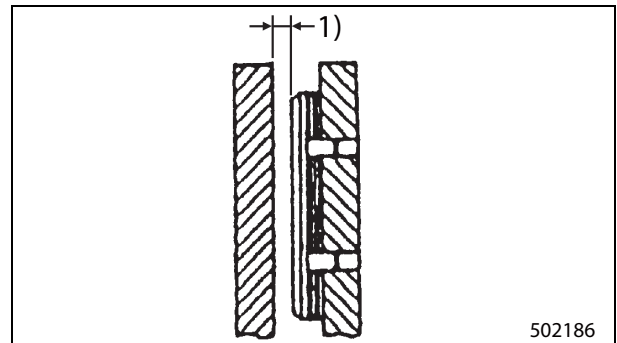

1) Clearance between mast and mast strip

Ref.	Item	Standard
1)	Clearance between mast and mast strip	0.1 to 0.5 mm (0.004 to 0.020 in.)

- (3) After all clearances are adjusted, move the mast and lift bracket slowly, and check whether the full stroke movement is smooth.

CLICK HERE TO **DOWNLOAD** THE COMPLETE MANUAL

- Thank you very much for reading the preview of the manual.
- You can download the complete manual from: [www.heydownloads.com](http://www.heydownloads.com) by clicking the link below



- Please note: If there is no response to CLICKING the link, please download this PDF first and then click on it.

CLICK HERE TO **DOWNLOAD** THE COMPLETE MANUAL