

PT240
Tier 3
Pneumatic Line Roller

SERVICE MANUAL

Part number 47703681

2nd edition English

September 2015

Replaces part number 84287260A



CLICK HERE TO **DOWNLOAD** THE COMPLETE MANUAL

- Thank you very much for reading the preview of the manual.
- You can download the complete manual from: www.heydownloads.com by clicking the link below



- Please note: If there is no response to CLICKING the link, please download this PDF first and then click on it.

CLICK HERE TO **DOWNLOAD** THE COMPLETE MANUAL

Safety rules - Ecology and the environment

Soil, air, and water quality is important for all industries and life in general. When legislation does not yet rule the treatment of some of the substances that advanced technology requires, sound judgment should govern the use and disposal of products of a chemical and petrochemical nature.

Familiarize yourself with the relative legislation applicable to your country, and make sure that you understand this legislation. Where no legislation exists, obtain information from suppliers of oils, filters, batteries, fuels, anti-freeze, cleaning agents, etc., with regard to the effect of these substances on man and nature and how to safely store, use, and dispose of these substances.

Helpful hints

- Avoid the use of cans or other inappropriate pressurized fuel delivery systems to fill tanks. Such delivery systems may cause considerable spillage.
- In general, avoid skin contact with all fuels, oils, acids, solvents, etc. Most of these products contain substances that may be harmful to your health.
- Modern oils contain additives. Do not burn contaminated fuels and or waste oils in ordinary heating systems.
- Avoid spillage when you drain fluids such as used engine coolant mixtures, engine oil, hydraulic fluid, brake fluid, etc. Do not mix drained brake fluids or fuels with lubricants. Store all drained fluids safely until you can dispose of the fluids in a proper way that complies with all local legislation and available resources.
- Do not allow coolant mixtures to get into the soil. Collect and dispose of coolant mixtures properly.
- The air-conditioning system contains gases that should not be released into the atmosphere. Consult an air-conditioning specialist or use a special extractor to recharge the system properly.
- Repair any leaks or defects in the engine cooling system or hydraulic system immediately.
- Do not increase the pressure in a pressurized circuit as this may lead to a component failure.
- Protect hoses during welding. Penetrating weld splatter may burn a hole or weaken hoses, allowing the loss of oils, coolant, etc.

Battery recycling

Batteries and electric accumulators contain several substances that can have a harmful effect on the environment if the batteries are not properly recycled after use. Improper disposal of batteries can contaminate the soil, groundwater, and waterways. CASE CONSTRUCTION strongly recommends that you return all used batteries to a CASE CONSTRUCTION dealer, who will dispose of the used batteries or recycle the used batteries properly. In some countries, this is a legal requirement.



Mandatory battery recycling

NOTE: The following requirements are mandatory in Brazil.

Batteries are made of lead plates and a sulfuric acid solution. Because batteries contain heavy metals such as lead, CONAMA Resolution 401/2008 requires you to return all used batteries to the battery dealer when you replace any batteries. Do not dispose of batteries in your household garbage.

Points of sale are obliged to:

- Accept the return of your used batteries
- Store the returned batteries in a suitable location
- Send the returned batteries to the battery manufacturer for recycling

Basic instructions - Shop and assembly

Shimming

For each adjustment operation, select adjusting shims and measure the adjusting shims individually using a micrometer, then add up the recorded values. Do not rely on measuring the entire shimming set, which may be incorrect, or the rated value shown on each shim.

Rotating shaft seals

For correct rotating shaft seal installation, proceed as follows:

1. Before assembly, allow the seal to soak in the oil it will be sealing for at least thirty minutes.
2. Thoroughly clean the shaft and check that the working surface on the shaft is not damaged.
3. Position the sealing lip facing the fluid.

NOTE: *With hydrodynamic lips, take into consideration the shaft rotation direction and position the grooves so that they will move the fluid towards the inner side of the seal.*

4. Coat the sealing lip with a thin layer of lubricant (use oil rather than grease). Fill the gap between the sealing lip and the dust lip on double lip seals with grease.
5. Insert the seal in its seat and press down using a flat punch or seal installation tool. Do not tap the seal with a hammer or mallet.
6. While you insert the seal, check that the seal is perpendicular to the seat. When the seal settles, make sure that the seal makes contact with the thrust element, if required.
7. To prevent damage to the seal lip on the shaft, position a protective guard during installation operations.

O-ring seals

Lubricate the O-ring seals before you insert them in the seats. This will prevent the O-ring seals from overturning and twisting, which would jeopardize sealing efficiency.

Sealing compounds

Apply a sealing compound on the mating surfaces when specified by the procedure. Before you apply the sealing compound, prepare the surfaces as directed by the product container.

Spare parts

Only use CNH Original Parts or CASE CONSTRUCTION Original Parts.

Only genuine spare parts guarantee the same quality, duration, and safety as original parts, as they are the same parts that are assembled during standard production. Only CNH Original Parts or CASE CONSTRUCTION Original Parts can offer this guarantee.

When ordering spare parts, always provide the following information:

- Machine model (commercial name) and Product Identification Number (PIN)
- Part number of the ordered part, which can be found in the parts catalog

(3) Tire inflation, (4) Tire deflation

These are used to inflate or deflate the tires with air.

NOTE: Do not switch ON both valves simultaneously to I position.

(5) Transmission fluid pressure gauge

The transmission fluid pressure must be within the range **12.5 - 15.5 bar (181.25 - 224.75 psi)**.

NOTE: When pressure drops below **12.5 bar (181.25 psi)**, stop the machine.

(6) Transmission fluid temperature

The operating temperature must be within the range **80 - 120 °C (176 - 248 °F)**. The maximum temperature is **120 °C (248 °F)**.

(7) Multifunctional display

Multifunctional instrument for displaying engine function and fuel reading.

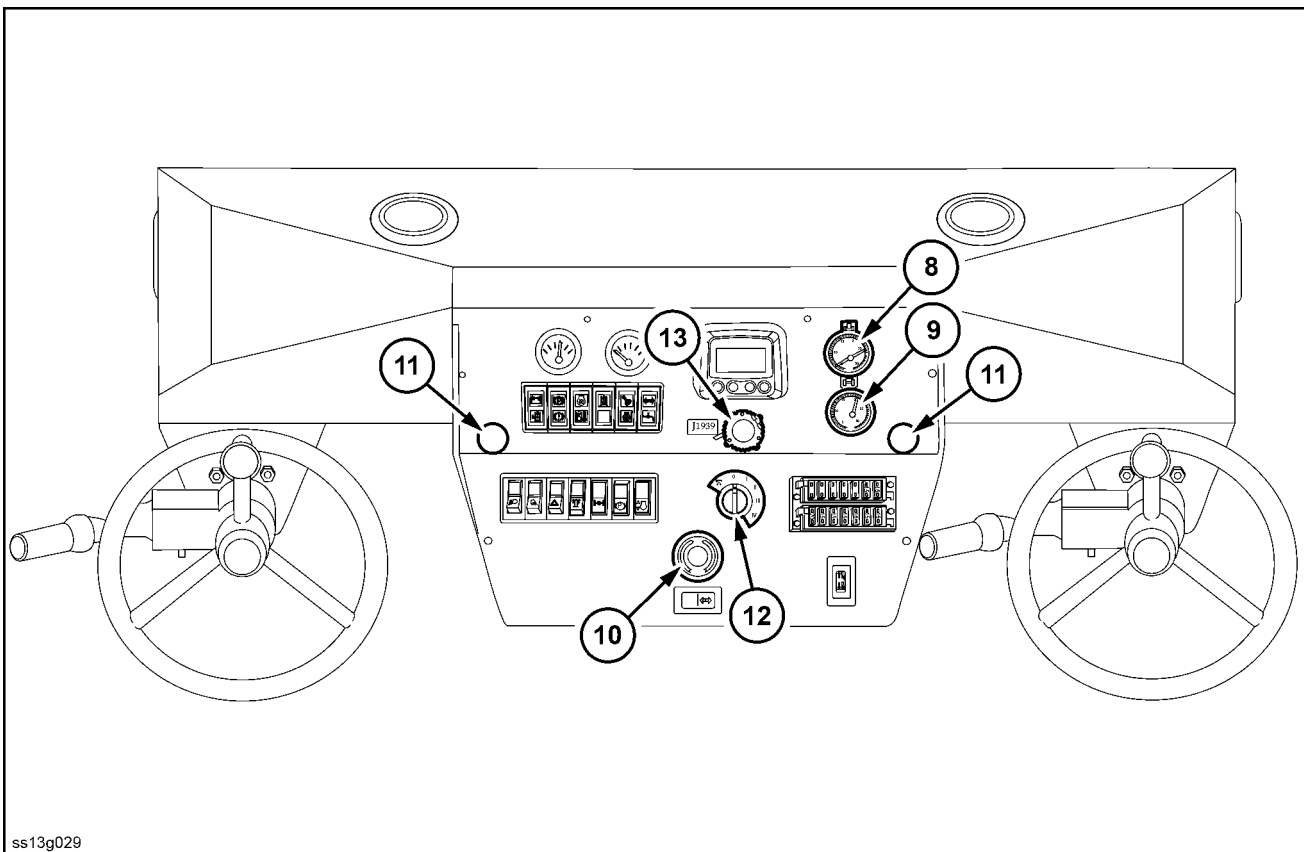

SS13G029 2

Instruments and controls

(8) Brake circuit pressure gauge

The white indicator shows air pressure inside the air reservoir. Adjusted to the maximum = **8 bar (116 psi)**. The red one indicates air pressure when braking. Air pressure from the air brake valve to the brake booster.

(9) Tire pressure gauge

The minimum air pressure after air release from tires has been adjusted to **1.5 - 2 bar (21.75 - 29 psi)**.

Product identification

PT240 LA --- NA ---

Write your machine model number, Product Identification Number (PIN), and serial numbers on the lines provided below. Always give these numbers and component plate numbers to your dealer when you need parts or information for your machine.

Make a record of the numbers. Keep this record and your manufacturers statement of origin in a safe place. If the machine is stolen, report the numbers to your local law enforcement agency.

Product identification plate provides the following information:

1. Type / Model
2. Product Identification Number (PIN)

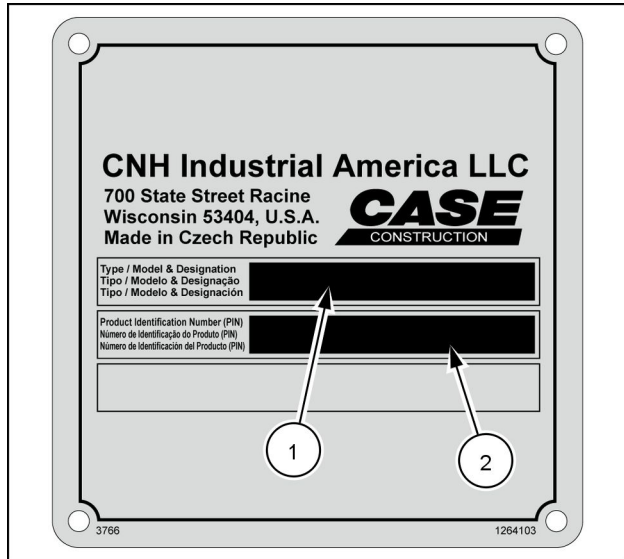

RAIL14COM0348BA 1

Pos.	Designation
1	Production label
2	Product Identification Number (PIN)

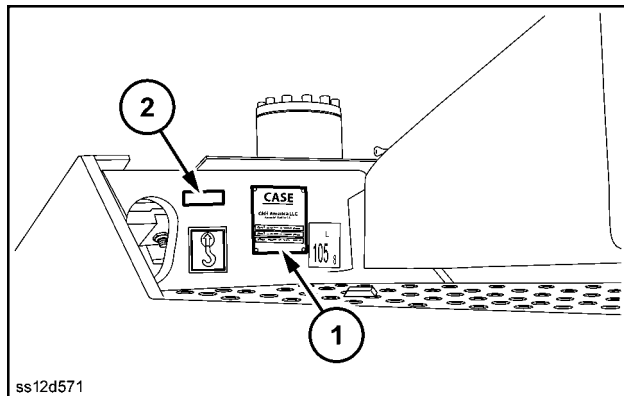

SS12D571 2

Contents

Engine - 10

Engine cooling system - 400

SERVICE

Radiator	
Drain fluid	3

Engine - Drain fluid

⚠ WARNING

Burn hazard!

Do not handle any service fluid (engine coolant, engine oil, hydraulic oil, etc.) at temperatures that exceed 49 °C (120 °F). Allow fluids to cool before proceeding.

Failure to comply could result in death or serious injury.

W0330B

⚠ WARNING

Chemical hazard!

When handling fuel, lubricants, and other service chemicals, follow the manufacturer's instructions. Wear Personal Protective Equipment (PPE) as instructed. Do not smoke or use open flame. Collect fluids in proper containers. Obey all local and environmental regulations when disposing of chemicals.

Failure to comply could result in death or serious injury.

W0371A

1. Remove the drain plug and let the oil flow out into a container with a capacity of approximately **9 L (2.38 US gal)**.
2. Reinstall the drain plug. Tighten to **80 N·m (59 lb ft)**.

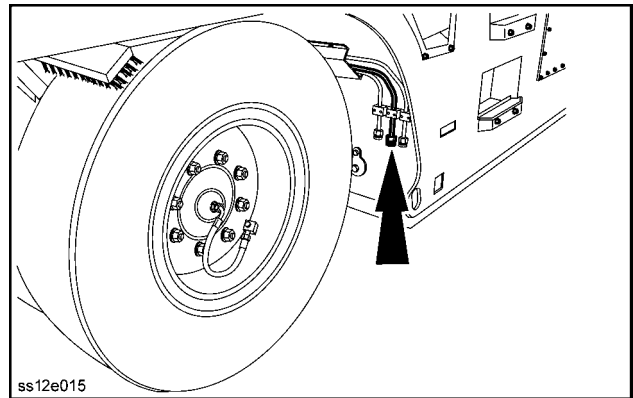

SS12E015 1

34. Fix a rope and a chain's strand to the cooler case.

NOTE: To lift the engine, use a shortening chain (toggle), e.g. Gunnebo.

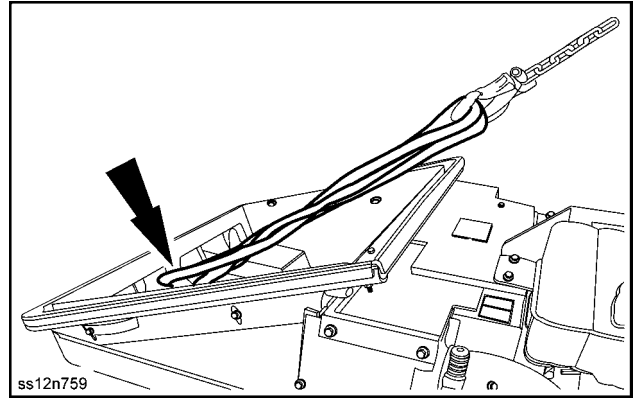

SS12N759 36

35. Fix the next chain strand to a jig, and to the loops of the engine.

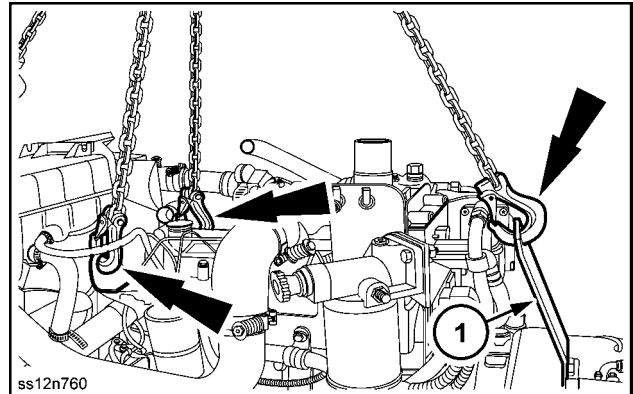

SS12N760 37

36. Adjust the individual strand of the chain so that the engine does not deviate from the vertical axis and horizontal axis when being lifted. It is only necessary to lift the engine slightly for the next removal operations.

NOTE: When handling, please pay attention to avoid any damage to the radiator or cooling fan.

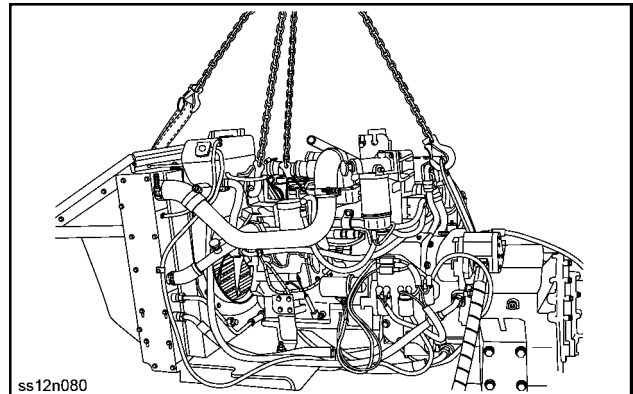

SS12N080 38

37. With the engine lifted slightly, remove the hydraulic oil hose.

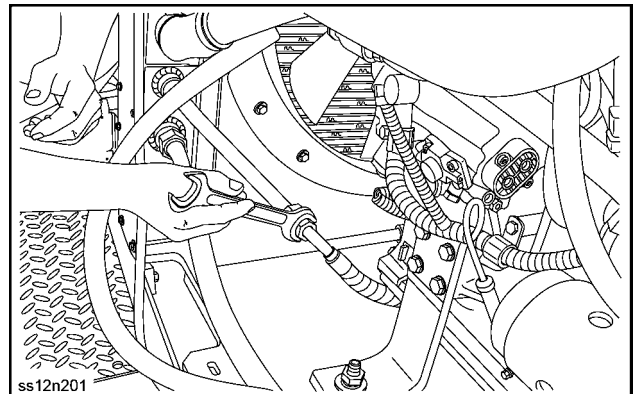

SS12N201 39

31. Attach the hydraulic oil hoses.

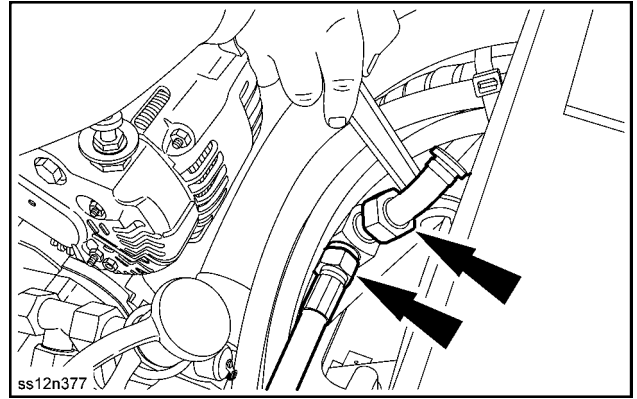

32. Install the bolts connecting the shaft to the transmission.

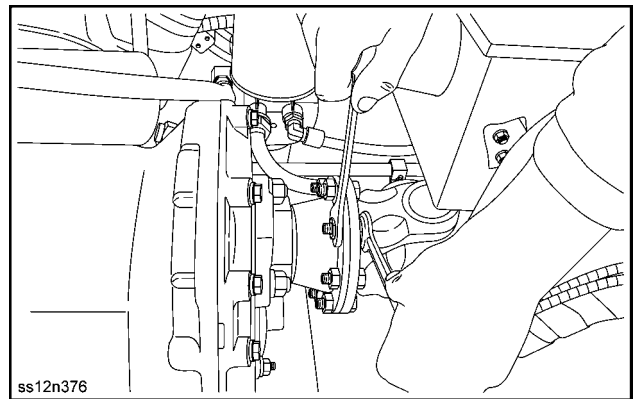

Mechanical transmission - Remove

Prior operation:

Remove the engine (refer to **Engine - Remove (10.001)**).

1. Remove the mounting cover from the transmission.

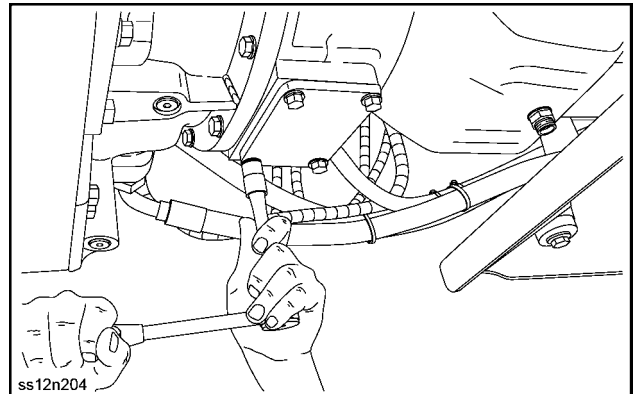

SS12N204 1

2. Slowly rotate the flywheel to remove the nuts used to secure the transmission clutch to the engine.

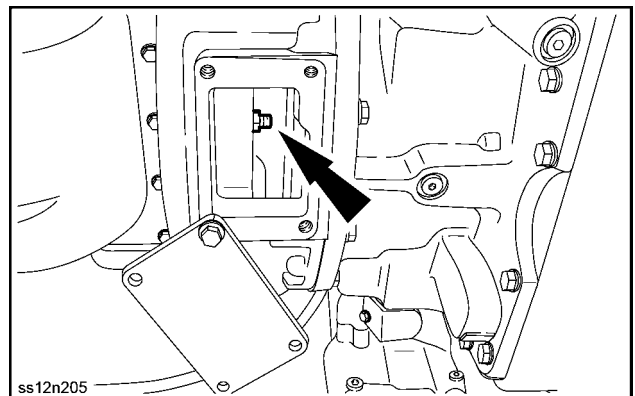

SS12N205 2

3. Loosen the transmission mounting to the engine.

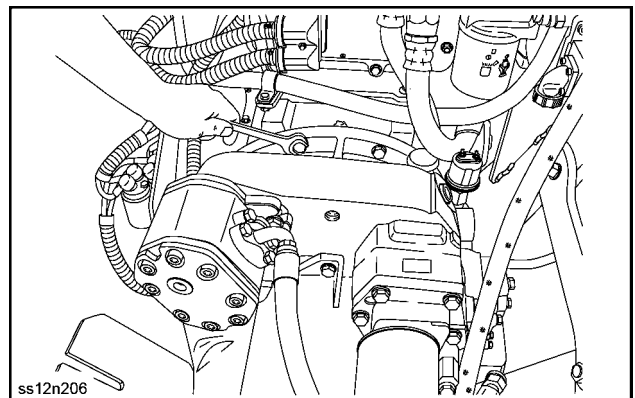

SS12N206 3

Contents

Front axle system - 25

Non-powered front axle - 400

FUNCTIONAL DATA

Front axle	
Component identification	3
Axle wheel hub	
Component identification	5
Sectional view	7

SERVICE

Front axle	
Remove	8
Install	10
Alignment	11
Axle wheel hub	
Replace – Seals	13
Disassemble	24
Assemble	25
End play	33

5. Slacken the bolts **(A)** on both connecting rods and turn the connecting rods **(17)** slightly to adjust the hub position.
Adjust so that the hubs of both legs touch the ruler (parallel position).
When adjusted, tighten the connecting rod bolts.

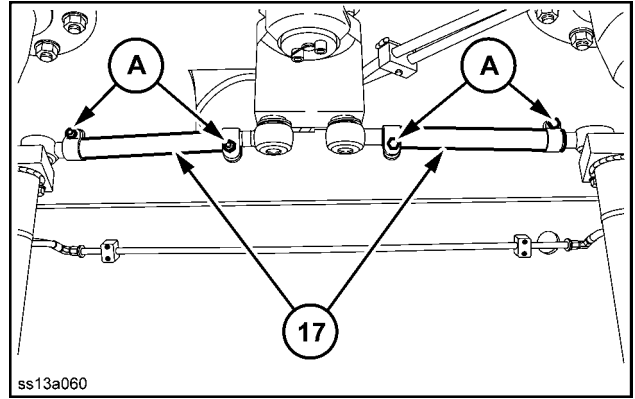

32. If no leaks are found, secure by snapping the cover against the release.

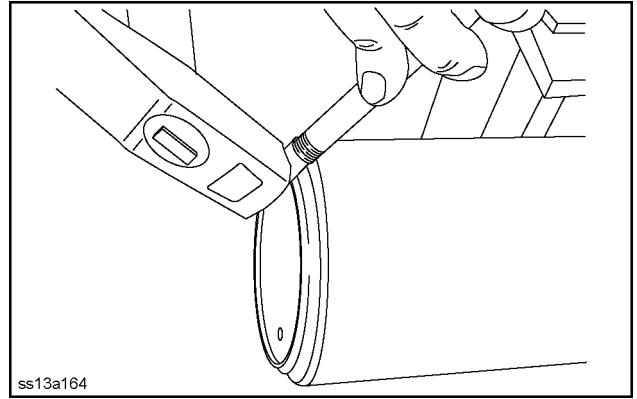

SS13A164 35

33. Remove the air valve and install a lifting jig.

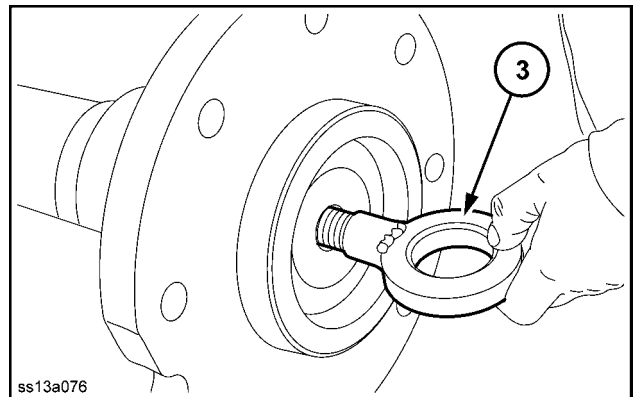

SS13A076 36

34. Use a lifting device to turn the assembly to the vertical position.

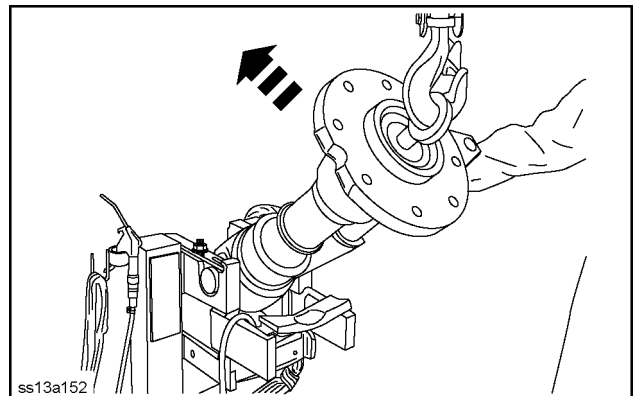

SS13A152 37

35. While slightly turning, slide the shaft into the cylinder.

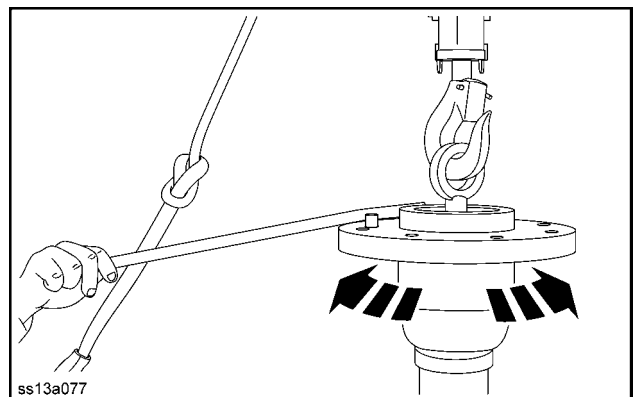

SS13A077 38

32. Install the upper halves of the bearing, secure the bolts with **LOCTITE® 262™**, and torque to **80 N·m (59 lb ft)**.

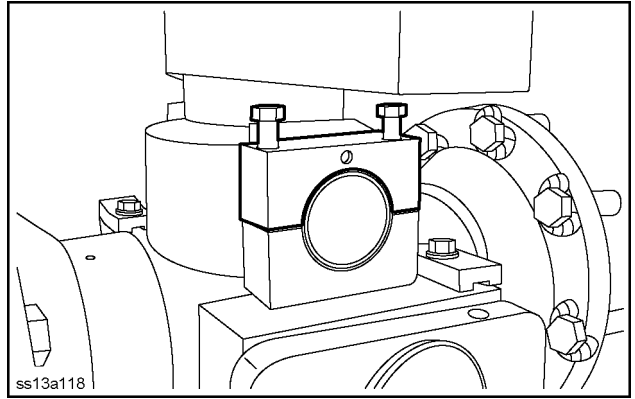

SS13A118 29

33. Tap the pin to the stop; and lock the ring (23) against rotation.

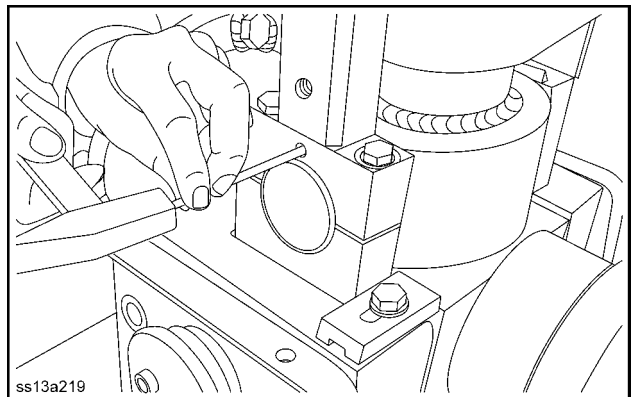

SS13A219 30

34. Install the cover (31) and insert the washer underneath the cover – take up the clearance between cover and shaft.

ATTENTION: Direct the cutout for the sprinkler hose ahead during axle reinstallation.

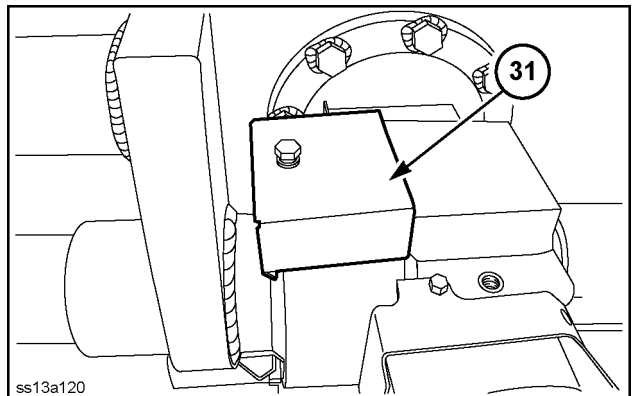

SS13A120 31

Rear axle system - Powered rear axle

Position	Designation	Position	Designation
1	Left-hand box	31	Ring
2	Right-hand box	32	Ring
4	Shaft	33	Oil seal
5	Intermediate gear	34	Nut
6	Gearwheel	35	Lock washer
7	Gear pin	37	Lock ring
8	Flange	38	Lock ring
10	Brake assembly	39	Lock ring
11	Brake drum	42	Bolt
12	Cover	43	Bolt
13	Bearing cover	44	Bolt
14	Bearing cover	45	Bolt
16	Spacer ring	46	Bolt
17	Cover	47	Bolt
18	Paper gasket	49	Bolt
19	Ring	50	Bolt
20	Shim	51	Nut
21	Shim	52	Nut
23	Spacer ring	55	Spring washer
25	Plug	56	Spring washer
27	Bearing	58	Spring washer
28	Bearing	59	Washer
29	Bearing	62	Bleeder valve

18. Remove the bolts securing the left seat.

NOTE: Remove the bolt inside the box (underneath the seat). This bolt secures the box to the machine frame.

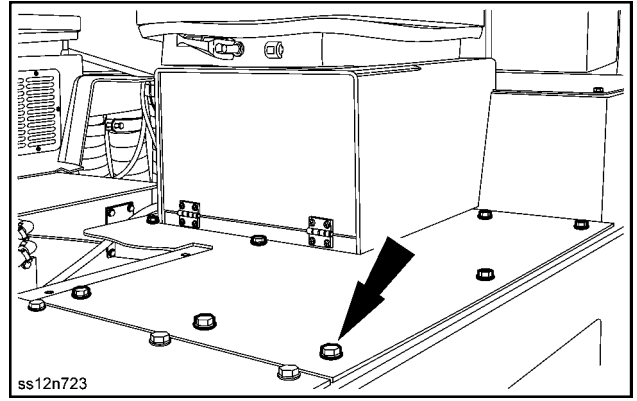

SS12N723 19

19. Undo the seven bolts along the perimeter of the cab. These bolts secure the cab to the machine frame.

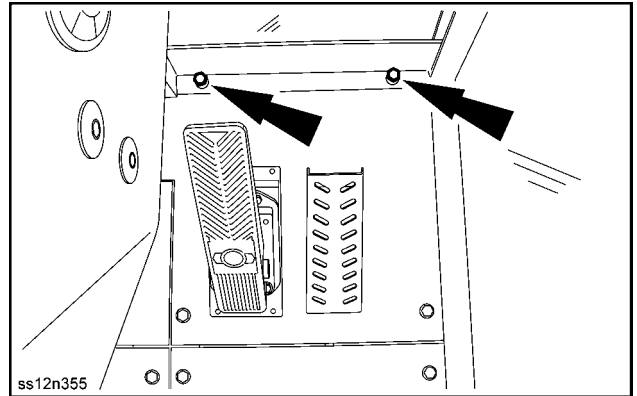

SS12N355 20

20. Lift the cab.

21. Remove the seat from the cab.

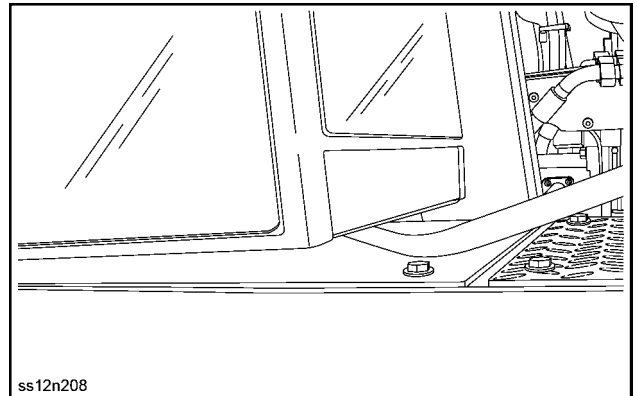

SS12N208 21

22. Lift the machine. Support the rear section of the machine along both sides.

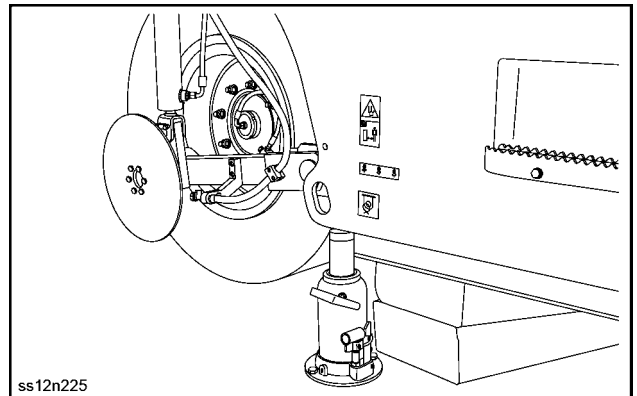

SS12N225 22

23. Turn off the parking brake.

6. Tap the oil seal (33) into the cover (12).
7. Apply **LOCTITE® 518™** to the contact surfaces of the cover (12) and the hub.
8. Fit the cover (12) onto the casing hub.

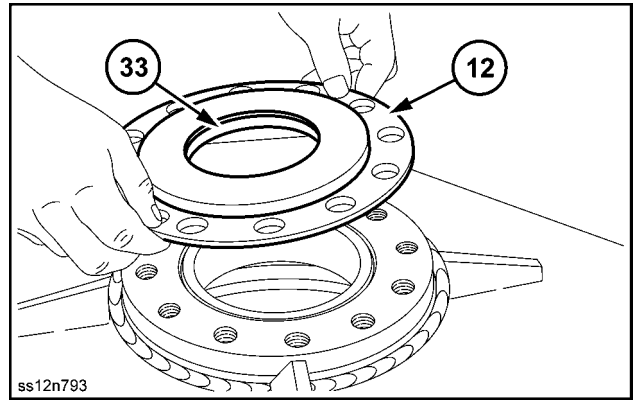

SS12N793 4

9. Apply **LOCTITE® 565™ PST** to the bolt threads.
10. Fit the brake device (10) onto the casing hub, and secure it with the bolts (47).

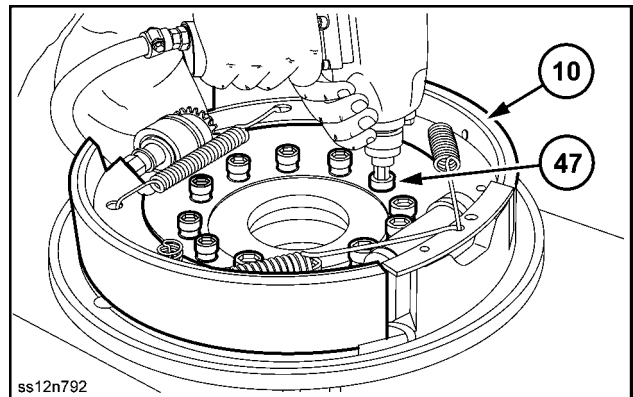

SS12N792 5

11. Turn the casing 90°.

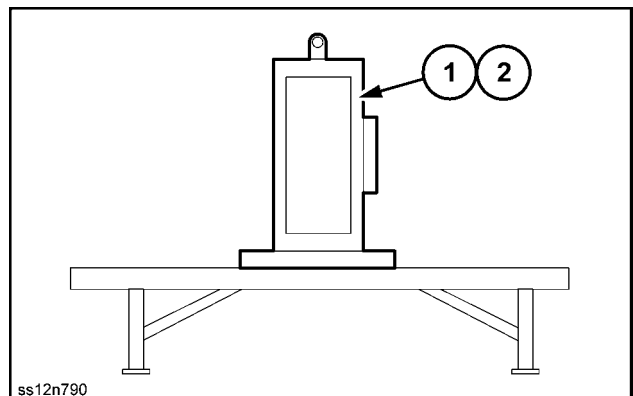

SS12N790 6

12. Slide the two complete intermediate gears (5) into the casing – one through the casing's rectangular hose and the other through the hole designed for the cover (13).

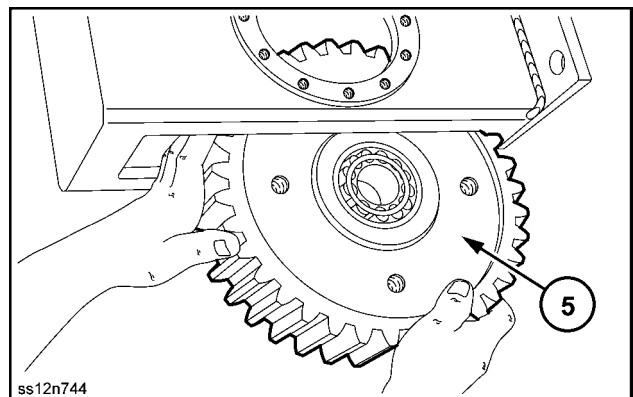

SS12N744 7

20. Install the steel sheets (E), (F).
21. Connect the lock wiring.

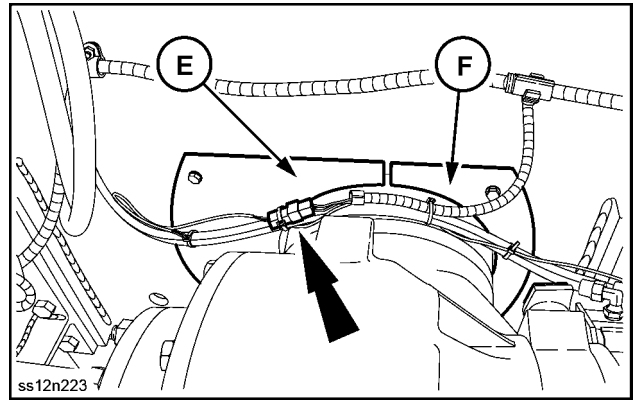

SS12N223 16

22. Install scrapers and sprinklers.

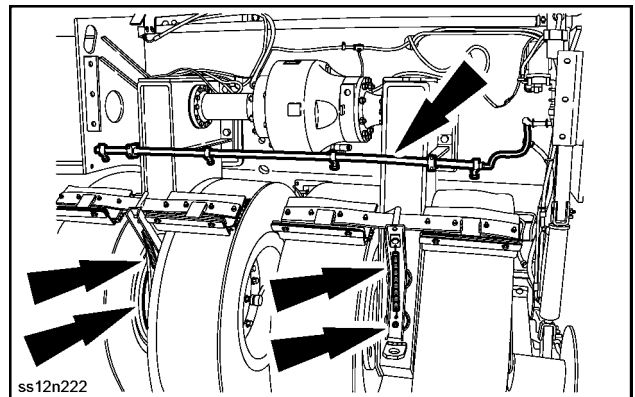

SS12N222 17

23. **▲ WARNING**
Falling object hazard!
DO NOT go underneath a hanging load. Make sure the area is clear of all bystanders. Failure to comply could result in death or serious injury.

W1129A

Lower the fuel tank into position.

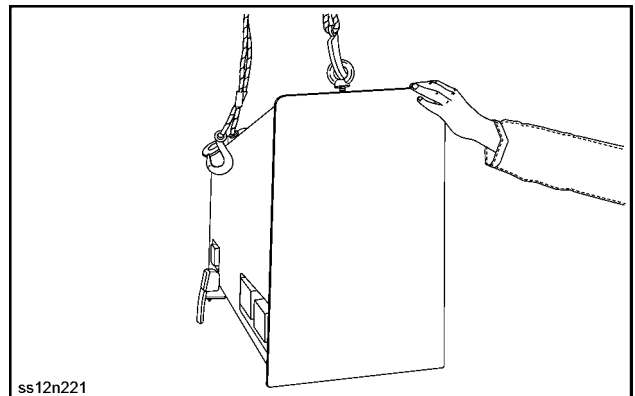

SS12N221 18

24. Install the bolts used to secure the tank to the machine frame (both sides).

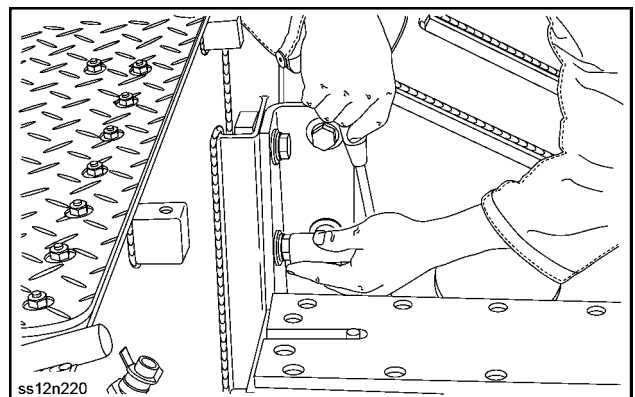

SS12N220 19

Final drive hub, steering knuckles, and shafts - Remove

⚠ DANGER

Heavy objects!

Lift and handle all heavy components using lifting equipment with adequate capacity. Always support units or parts with suitable slings or hooks. Make sure the work area is clear of all bystanders. Failure to comply will result in death or serious injury.

D0076A

NOTE: For more details, refer to **Powered rear axle - Component identification (27.100)**.

1. Hang the final drive onto a suspension device, using a jig (4).

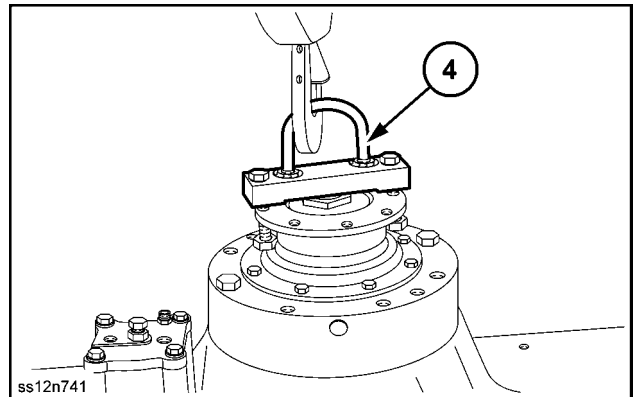

2. Remove the cover (14).

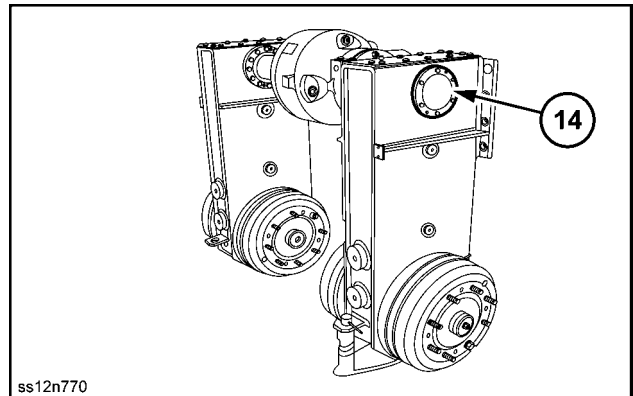

3. Use an adequate lifting device to suspend the final drive (13) and drive castings.
4. Unbolt the axle shafts (1), (2) from the drive castings.
5. Carefully remove the drive castings from the axle shafts.

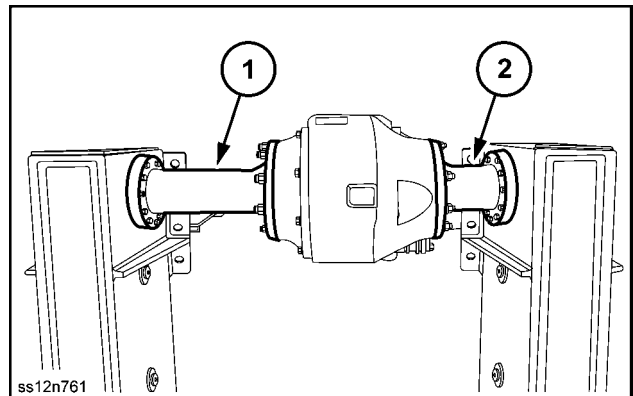

Contents

Brakes and controls - 33

[33.300] Pneumatic service brakes.....	33.1
[33.110] Parking brake or parking lock	33.2

5. Lift the cab so that the seat can be moved.

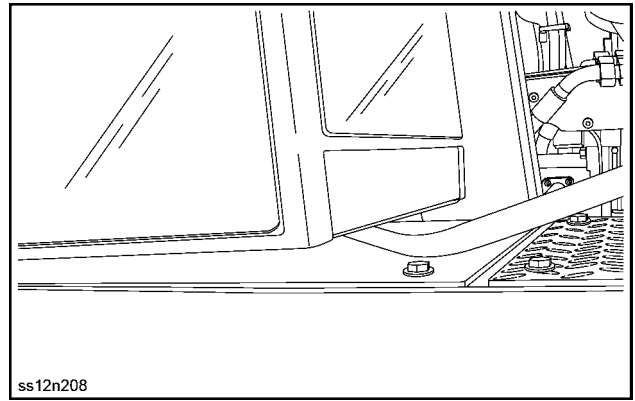

SS12N208 5

6. Take the seat out of the cab.

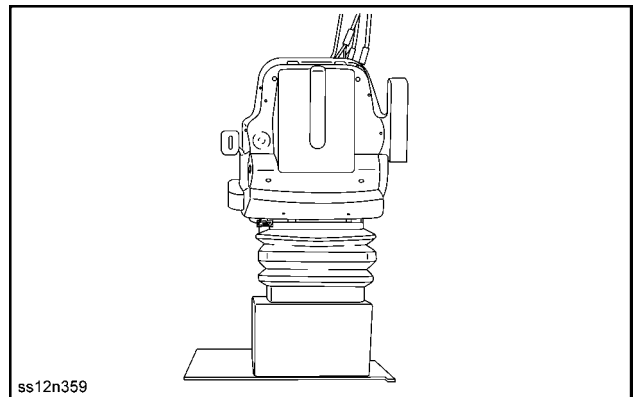

SS12N359 6

7. Remove the booster bolts.

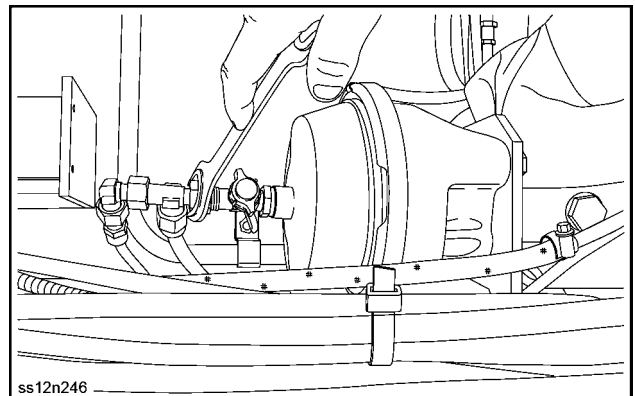

SS12N246 7

8. Remove the booster bracket.

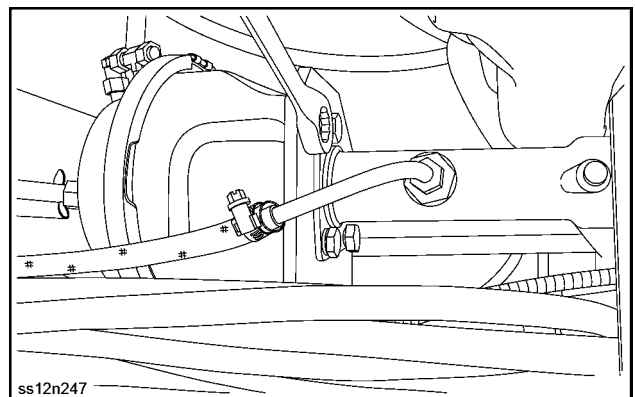

SS12N247 8

Contents

Brakes and controls - 33

Parking brake or parking lock - 110

FUNCTIONAL DATA

Parking brake or parking lock	
Component identification	3
Static description	5

SERVICE

Parking brake discs	
Remove	6
Install	7
Parking brake caliper	
Remove	8
Install	12

Parking brake caliper - Install

NOTE: For more details, refer to **Parking brake or parking lock - Component identification (33.110)**.

1. If necessary, replace the brake pads at this time.

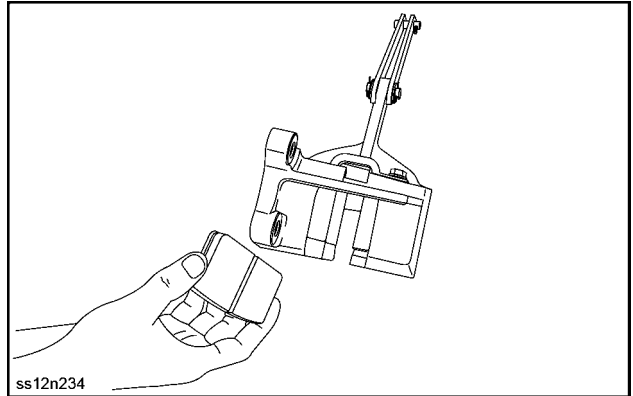

SS12N234 1

2. Place the caliper in position, and install. Torque the bolts to specification. Please see **Torque ()** for specification.

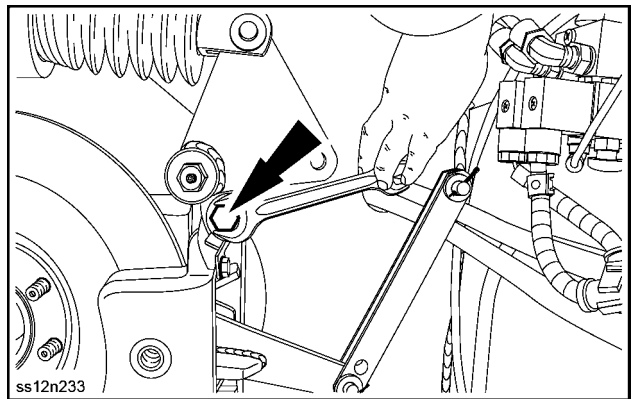

SS12N233 2

3. Connect the pull rods.

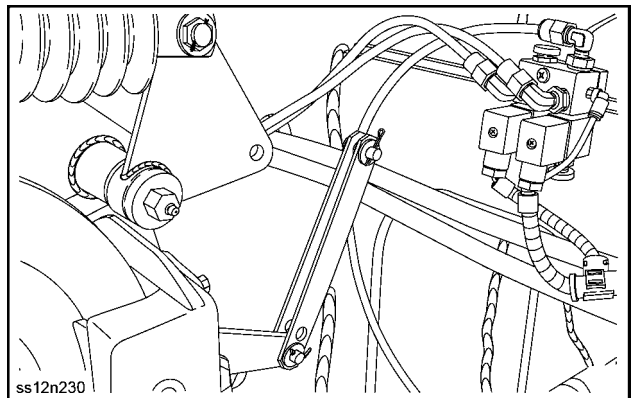

SS12N230 3

4. Install the upper pin, and install the split pin.

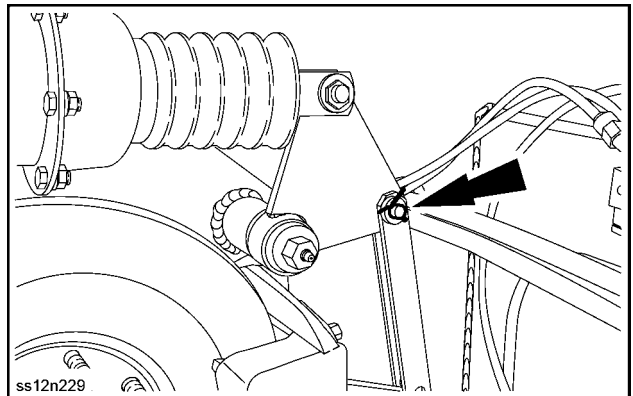

SS12N229 4

CLICK HERE TO **DOWNLOAD** THE COMPLETE MANUAL

- Thank you very much for reading the preview of the manual.
- You can download the complete manual from: www.heydownloads.com by clicking the link below



- Please note: If there is no response to CLICKING the link, please download this PDF first and then click on it.

CLICK HERE TO **DOWNLOAD** THE COMPLETE MANUAL

Oil filters - Replace

⚠ WARNING

Burn hazard!

Do not handle any service fluid (engine coolant, engine oil, hydraulic oil, etc.) at temperatures that exceed 49 °C (120 °F). Allow fluids to cool before proceeding.
Failure to comply could result in death or serious injury.

W0330B

⚠ WARNING

Chemical hazard!

When handling fuel, lubricants, and other service chemicals, follow the manufacturer's instructions. Wear Personal Protective Equipment (PPE) as instructed. Do not smoke or use open flame. Collect fluids in proper containers. Obey all local and environmental regulations when disposing of chemicals.
Failure to comply could result in death or serious injury.

W0371A

1. Open the cover.
2. With a suitable container of adequate capacity, drain the oil via the valve (Approximate drain volume: **22 L (5.81 US gal)**).
3. When drained, close the valve.

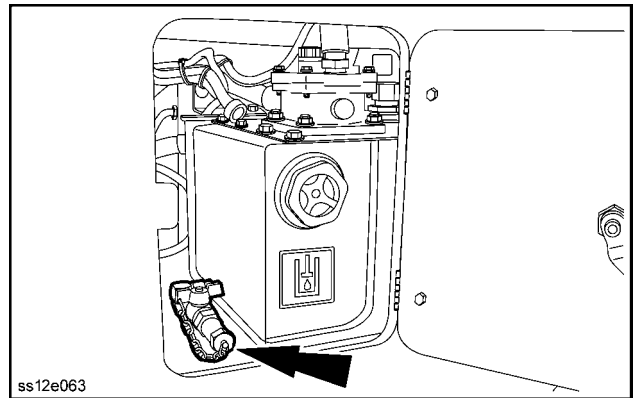

SS12E063 1

4. Remove the cover.

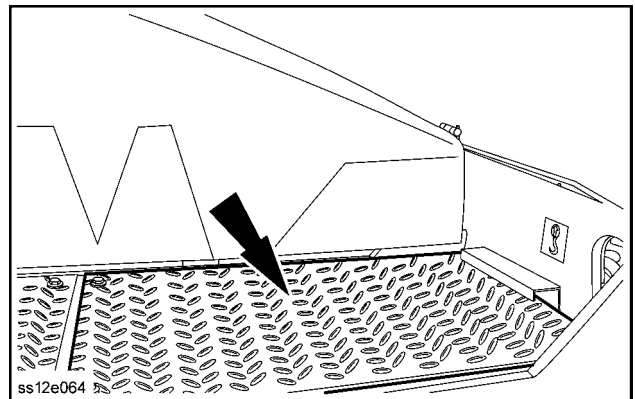

SS12E064 2

5. Disconnect the clogged filter sensor (1).
6. Remove the filter cover (2).

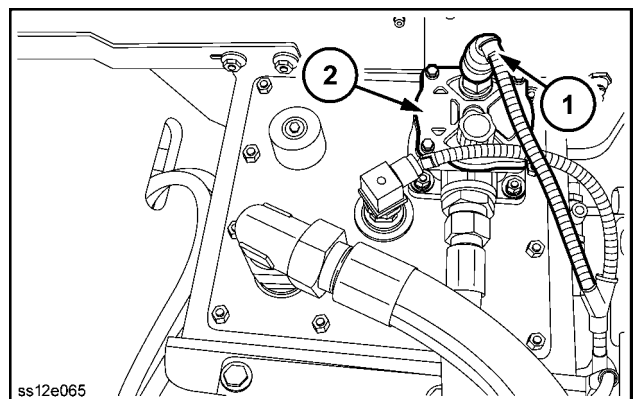

SS12E065 3

Contents

Pneumatic system - 36

Pneumatic system - 100

SERVICE

Pneumatic system dryer

Remove 3

5. Remove the clamp.

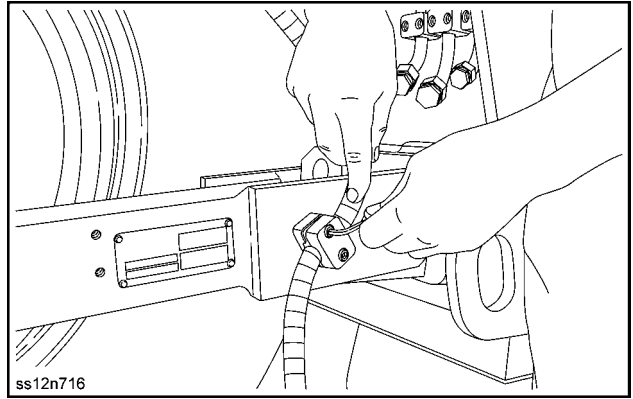

SS12N716 5

6. Remove the packing piece (A), drive out the pin (B), and remove the pipe (C).

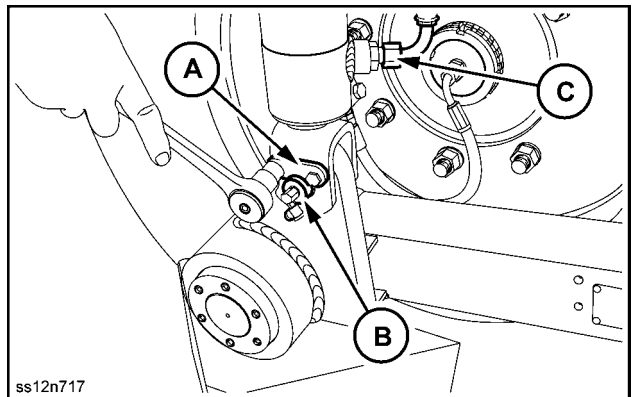

SS12N717 6

7. Swing the hydromotor, lift the arm slightly to access the bolts used for mounting to the frame, and remove the four bolts used for mounting the arm to the frame.

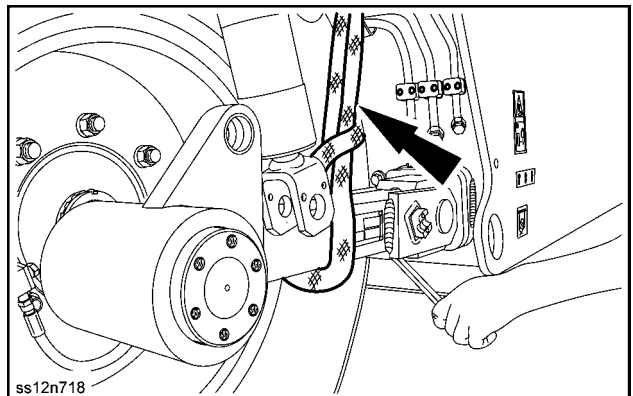

SS12N718 7

8. Put aside the removed arm.

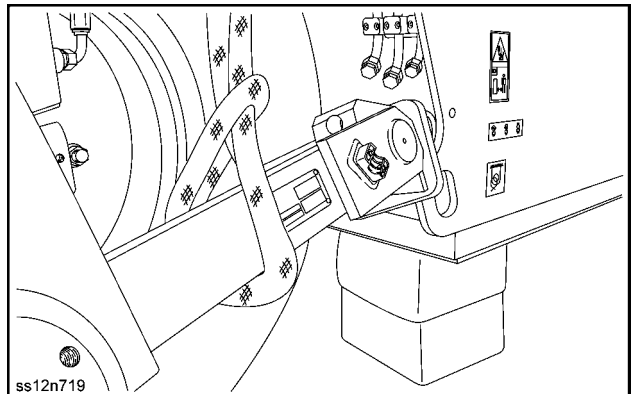

SS12N719 8

Steering column - Remove

1. Remove the cover in the center of the steering column. Unscrew the nut **(A)**, insert jig no. **(1)** (refer to **Special tools** (j)) under the steering wheel, and use the puller to take off the steering wheel.

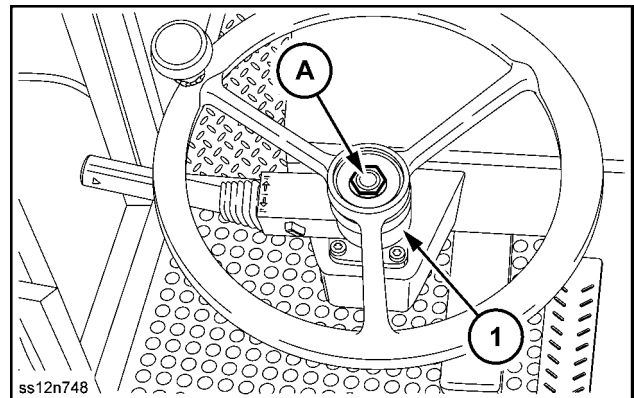

SS12N748 1

2. Remove the travel controller sleeve **(B)**.

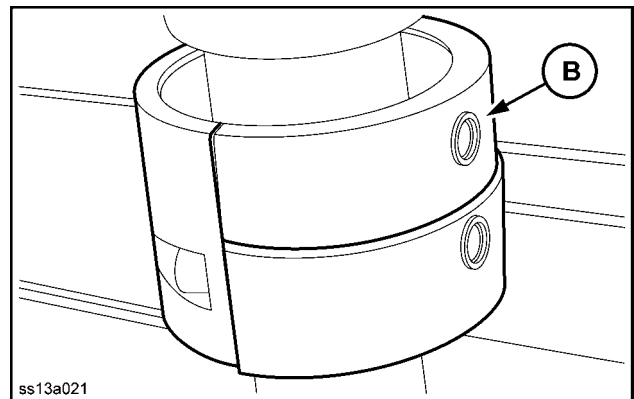

SS13A021 2

3. With the bolts **(C)** removed, detach the steering servo and remove the steering column by the lower end.

NOTE: Lubricate the grooved shaft of the column with grease, when reinstalling.

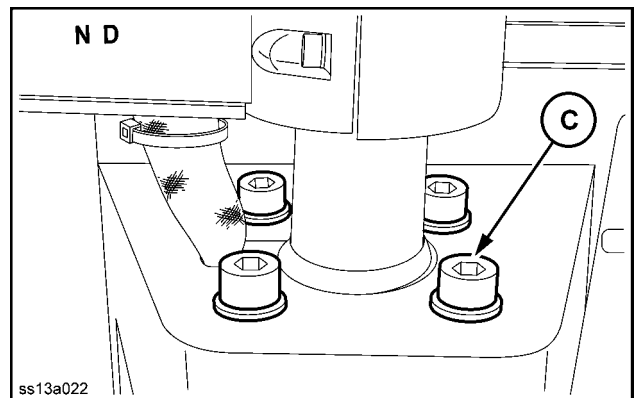

SS13A022 3

5. Remove the suction flange.

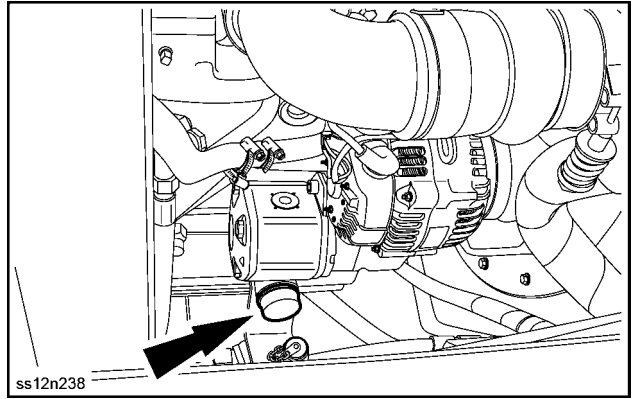

SS12N238 5

6. Remove the pump.

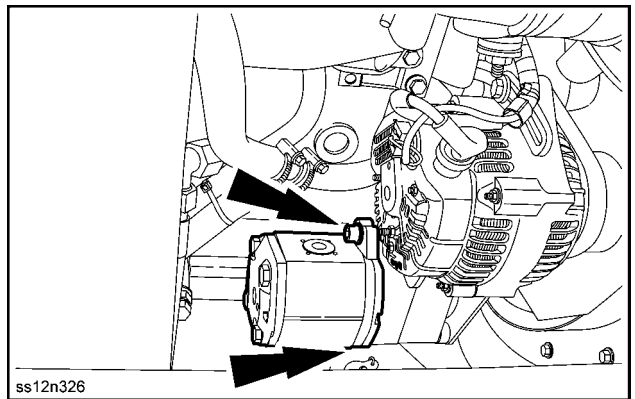

SS12N326 6

5. Remove the piston nut and reseal (recaulk) the piston together with the cover.

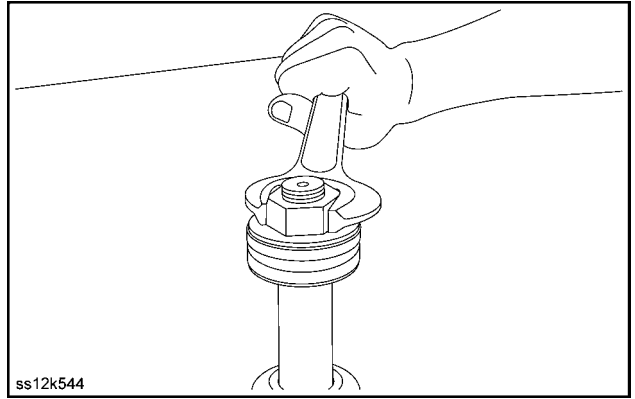

SS12K544 5

6. Mount the jig (3) (refer to **Special tools** ()) in the hydromotor body.

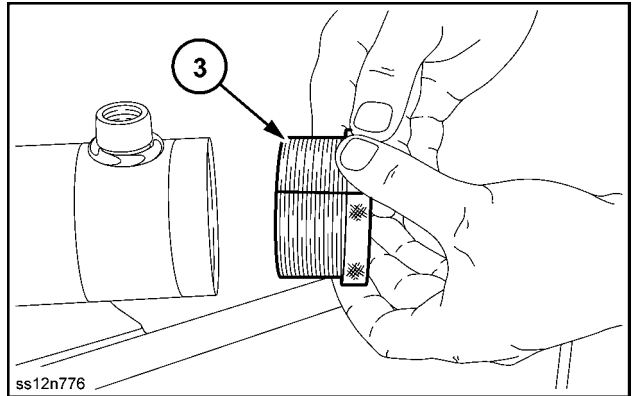

SS12N776 6

7. Insert the piston.

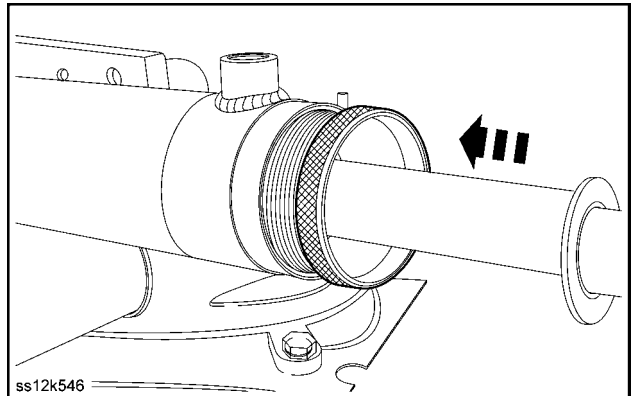

SS12K546 7

8. Remove the jig from the hydromotor.

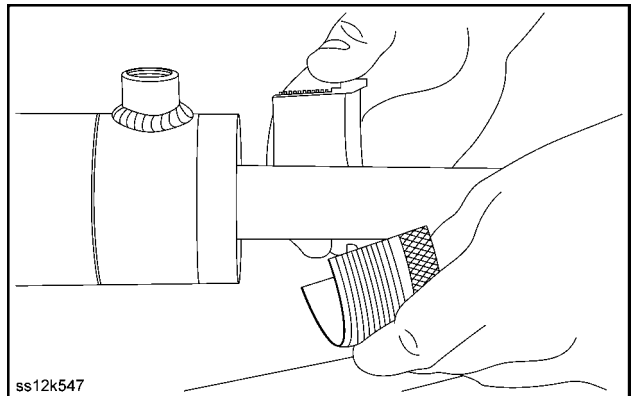

SS12K547 8

Front wheels - Torque

⚠ DANGER

Heavy objects!

Lift and handle all heavy components using lifting equipment with adequate capacity. Always support units or parts with suitable slings or hooks. Make sure the work area is clear of all bystanders. Failure to comply will result in death or serious injury.

D0076A

⚠ WARNING

Unexpected movement!

Secure the machine to prevent inadvertent movements. Failure to comply could result in death or serious injury.

W1060A

1. Torque the lug nuts (**A**) in a star pattern as shown in Figure 1. Torque the lug nuts (**A**) to **400.0 N·m (295.0 lb ft)**.

NOTICE: Make sure to check the torque on the lug nuts (**A**) after every two hours of operation until the torque stabilizes.

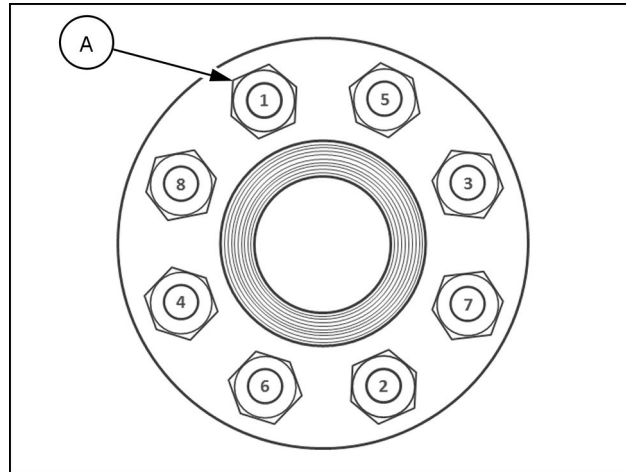

RAPH15COM0330BA 1

Contents

Wheels - 44

Rear wheels - 520

TECHNICAL DATA

Rear wheels	
Tire pressure - Central Air Inflation	3
Tire pressure	4

SERVICE

Rear wheel	
Remove	6
Install	9

Index

Wheels - 44

Rear wheels - 520

Rear wheel - Install	9
Rear wheel - Remove	6
Rear wheels - Tire pressure	4
Rear wheels - Tire pressure - Central Air Inflation	3

Contents

Cab climate control - 50

Air conditioning - 200

TECHNICAL DATA

Air conditioning	
General specification	3

FUNCTIONAL DATA

Air conditioning	
Overview	4

SERVICE

Air conditioning	
Replace – Filter	5

DIAGNOSTIC

Air conditioning	
Troubleshooting	6

Contents

Electrical systems - 55

Electrical system - 000

FUNCTIONAL DATA

Electrical system

Wiring harnesses - Component localization	3
---	---

Schematic one of two

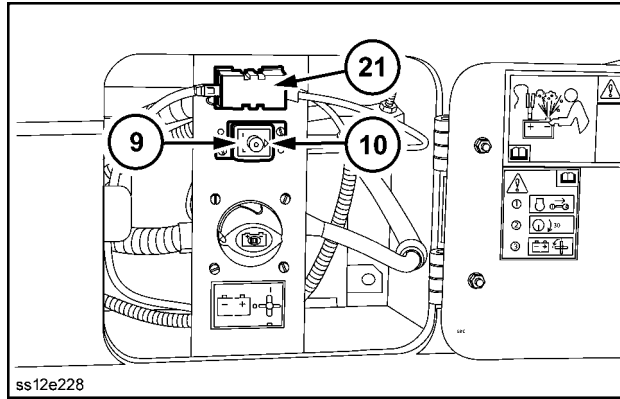

ss12e228

SS12E228 2

	Rating	Description		Rating	Description
F9	30 A	Engine Control Module (ECM) (9)	F21	80 A	Main fuse (21)
F10		Reserved for radio (10)			

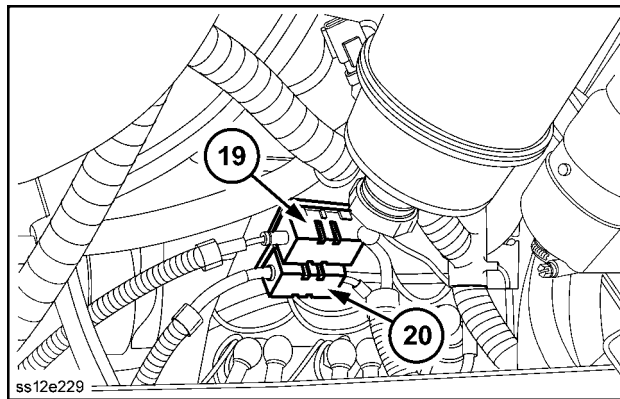

ss12e229

SS12E229 3

	Rating	Description		Rating	Description
F19	125 A	Preheating (19)	F20	125 A	Preheating (20)

Contents

Electrical systems - 55

Alternator - 301

FUNCTIONAL DATA

Alternator	
Static description	3

SERVICE

Alternator	
Check	5

DIAGNOSTIC

Alternator	
Troubleshooting	6

Recharge the batteries following 2 months of decommissioning.

⚠ DANGER

Explosion hazard!

Batteries emit explosive gases. Always ventilate when using in an enclosed area or when charging.

Keep the battery away from sparks, open flames, and other ignition sources.

Failure to comply will result in death or serious injury.

D0116A

⚠ WARNING

Battery gas can explode!

To prevent an explosion: 1. Always disconnect the negative (-) battery cable first. 2. Always connect the negative (-) battery cable last. 3. Do not short circuit the battery posts with metal objects. 4. Do not weld, grind, or smoke near a battery.

Failure to comply could result in death or serious injury.

W0011A

⚠ WARNING

Hazardous chemicals!

Battery electrolyte contains sulfuric acid. Contact with skin and eyes could result in severe irritation and burns. Always wear splash-proof goggles and protective clothing (gloves and aprons). Wash hands after handling.

Failure to comply could result in death or serious injury.

W0006A

5. Move the cursor (1) to SETUP 1 - UP DISPLAY. Confirm with Enter (2).

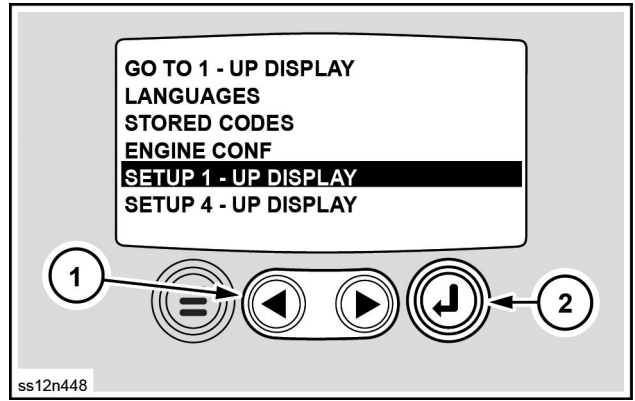

SS12N448 5

6. Move the cursor (1) to UTILITIES. Confirm with Enter (2).

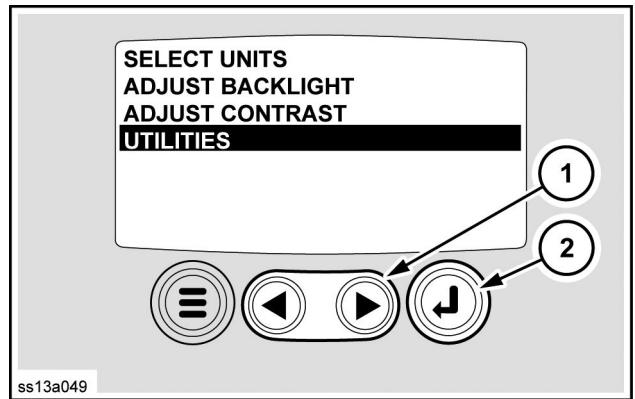

SS13A049 6

7. Move the cursor (1) to ANALOG INPUT. Confirm with Enter (2).

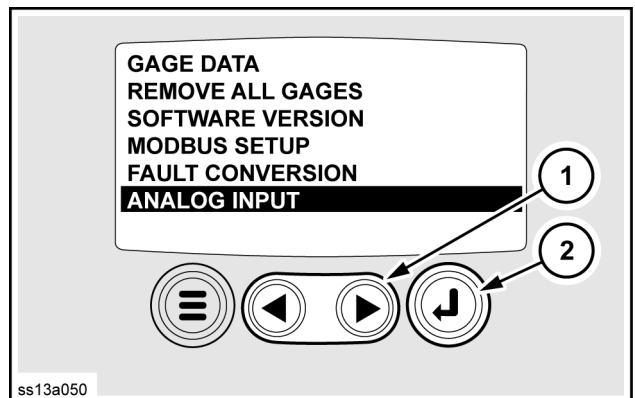

SS13A050 7

8. Move the cursor (1) to FUEL LEVEL. Confirm with Enter (2).

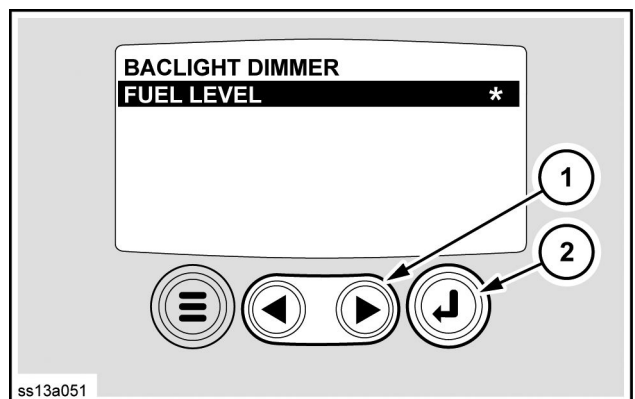

SS13A051 8

Contents

Electrical systems - 55

Electronic modules - 640

FUNCTIONAL DATA

Controller Area Network (CAN) data bus

Dynamic description	3
---------------------------	---

- Press the Enter button to access the "Go To 4 up display" screen.

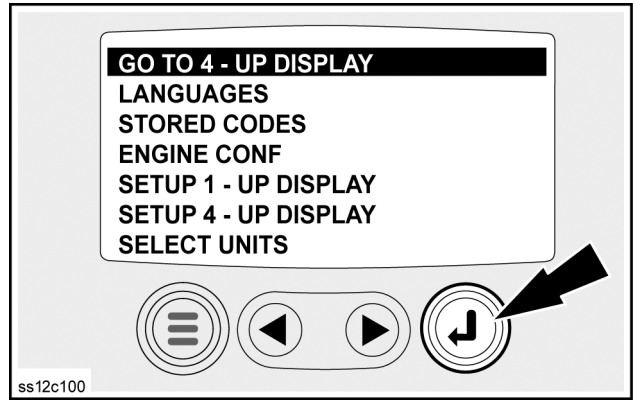

- Four-parameter display will be displayed. Press the Menu button to display main menu.

NOTE: Four-parameter display is the default screen; turn On the Ignition switch to display this screen.

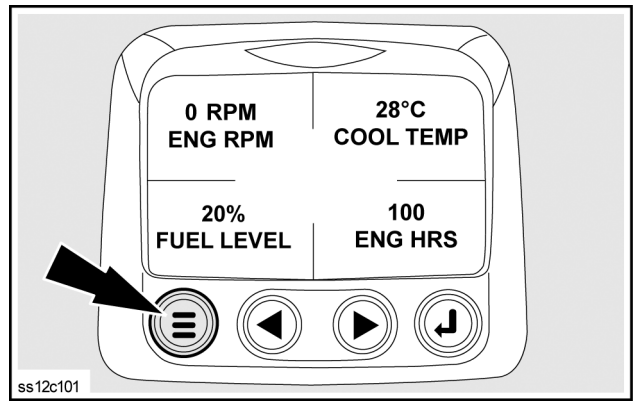

- By pressing the left or right arrow, the four additional parameters are displayed.

NOTE: By pressing the left/right button, it's possible to switch between the two main four-parameter views.

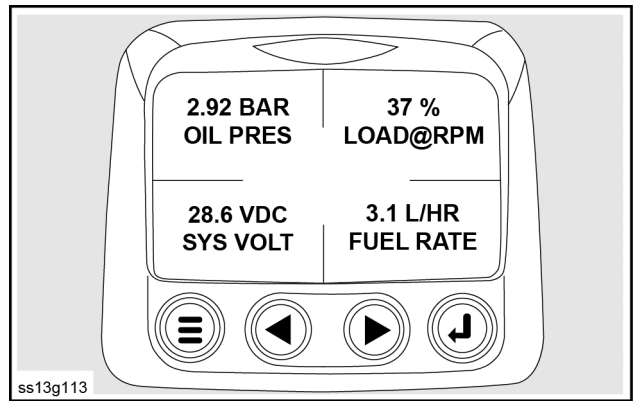

Contents

Electrical systems - 55

Warning indicators, alarms, and instruments - 408

FUNCTIONAL DATA

Instrument cluster	
Fault code index	3

SERVICE

Instrument cluster	
Replace	13
Adjust	14

DIAGNOSTIC

Instrument cluster	
Troubleshooting	15

Electrical systems - Warning indicators, alarms, and instruments

3318	Amber	Not available	After-treatment 1 diesel particulate filter intake temperature - data erratic, intermittent or incorrect
3325	Amber	Not available	After-treatment 1 diesel oxidation catalyst intake temperature swapped - out of calibration
3326	Red	Not available	SAE J1939 multiplexed accelerator pedal or lever sensor system - abnormal update rate
3328	Amber	Not available	Transmission output shaft speed - abnormal update rate
3329	Amber	Message selection control	J1939 Network #2 - data erratic, intermittent or incorrect
3331	Amber	Not available	J1939 Network #3 - data erratic, intermittent or incorrect
3369	Amber	Not available	Turbocharger 1 compressor inlet temperature sensor - abnormal update rate
3371	Amber	Not available	Turbocharger 1 compressor inlet temperature sensor - received network data In error
3372	Amber	Not available	Turbocharger 1 compressor inlet pressure - abnormal update rate
3373	Amber	Not available	Turbocharger 1 compressor inlet pressure - received network data In error
3377	Amber	Not available	Engine crankcase ventilation hose disconnected - condition exists
3712	Red	Not available	After-treatment SCR operator inducement - data valid but above normal operational range - most severe level
3727	NA	Not available	High pressure common rail fuel pressure relief valve - mechanical system not responding or out of adjustment
3737	NA	Not available	Engine starter mode Over-crank protection - condition exists
3918	Amber	Not available	Engine turbocharger wastegate Actuator - Out of Calibration
3921	Amber	Not available	Engine turbocharger waste gate actuator - mechanical system not responding or out of adjustment
3922	Amber	Not available	Engine turbocharger waste gate actuator - current below normal or open circuit
3923	Amber	Not available	Engine turbocharger waste gate actuator - current above normal or grounded circuit
3924	Amber	Not available	Utility reverse kW fault - condition exists
3925	Amber	Not available	Engine turbocharger waste gate actuator 1 position - data erratic, intermittent or incorrect
3927	Amber	Not available	Engine turbocharger waste gate actuator - root cause not known
3928	Amber	Not available	Engine turbocharger waste gate actuator - condition exists



PRINTED IN U.S.A.

© 2015 CNH Industrial America LLC.

All rights reserved. No part of the text or illustrations of this publication may be reproduced.

CASE CONSTRUCTION policy is one of continuous improvement and the right to change prices, specification or equipment at any time without notices is reserved.

All data given in this publication is subject to production variations. Dimensions and weight are approximate only and the illustrations do not necessarily show products in standard condition. For exact information about any particular product, please consult your CASE CONSTRUCTION Dealer.

Contents

Platform, cab, bodywork, and decals - 90

[90.150] Cab.....	90.1
[90.114] Operator protections	90.2
[90.100] Engine hood and panels	90.3

17. Remove four hoses.

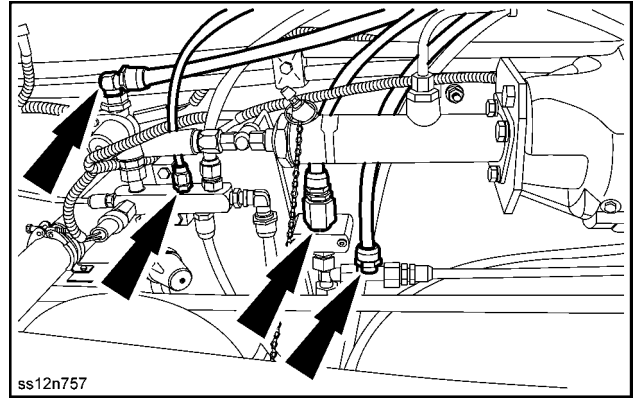

SS12N757 17

18. Remove the hose and cut off the retaining straps.

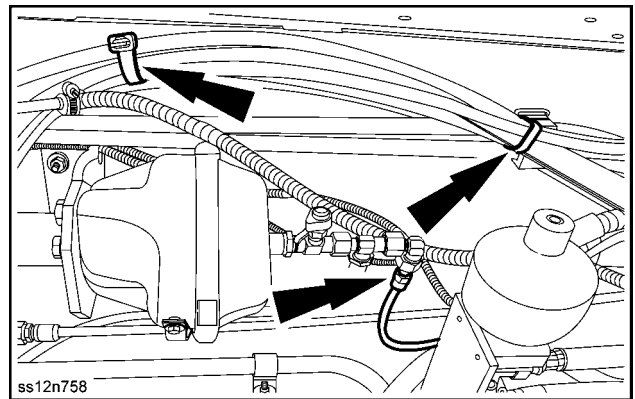

SS12N758 18

19. Remove the air distribution hoses. Move the panel aside off of the machine.

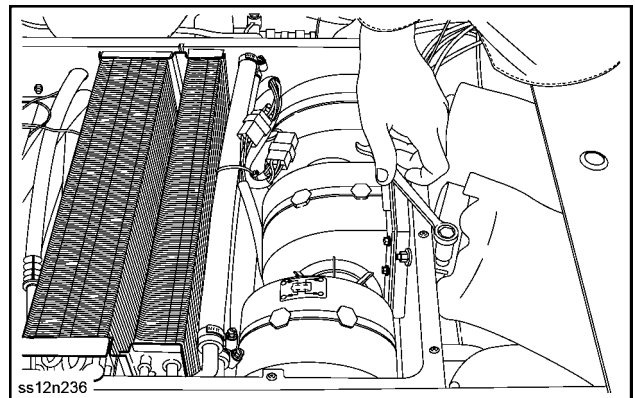

SS12N236 19

CLICK HERE TO **DOWNLOAD** THE COMPLETE MANUAL

- Thank you very much for reading the preview of the manual.
- You can download the complete manual from: www.heydownloads.com by clicking the link below



- Please note: If there is no response to CLICKING the link, please download this PDF first and then click on it.

CLICK HERE TO **DOWNLOAD** THE COMPLETE MANUAL