



SERVICE MANUAL



**PUMA 130 CVX , PUMA 130 , PUMA 145 CVX , PUMA 145 , PUMA 160 CVX
 , PUMA 160**

CLICK HERE TO **DOWNLOAD** THE COMPLETE MANUAL

- Thank you very much for reading the preview of the manual.
- You can download the complete manual from: www.heydownloads.com by clicking the link below



- Please note: If there is no response to CLICKING the link, please download this PDF first and then click on it.

CLICK HERE TO **DOWNLOAD** THE COMPLETE MANUAL

INTRODUCTION

Sulphur Content	Oil Change Period
Below 0.5 %	Normal
From 0.5 - 1.0 %	Half the normal
Above 1.0 %	One quarter normal

NOTE: The use of fuel with a sulphur content above **1.3 %** is not recommended.

Coolants

▲ WARNING

Hazardous chemicals!

Chemical agent may be harmful.

-Avoid contact with eyes, and prolonged/repeated skin contact.

-Wear protective goggles when handling.

-Eye contact: Flush with water for 15 minutes. Seek immediate medical assistance.

-Wash skin with soap and water after handling.

-Keep out of reach of children.

Failure to comply could result in death or serious injury.

W0370A

To reduce the amount of deposits and corrosion, the water used in the cooling system must comply with the following values.

Total Hardness	Chloride	Sulphate
300 parts per million	100 parts per million	100 parts per million

Using Plain water

If you reside in a country where antifreeze is not available, use clean water premixed with **5 %** chemical inhibitor. The inhibitor is available from your authorised dealer.

Lubrications and Coolant Specifications

RECOMMENDED FLUIDS AND APPLICATIONS	CIH SPECIFICATION	INTERNATIONAL SPECIFICATION
ENGINE OIL CASE IH AKCELA NO. 1 ENGINE OIL 15W-40 CASE IH AKCELA NO. 1 ENGINE OIL 10W-30	MS 1121	API CI-4, ACEA E7
TRANSMISSION, REAR AXLE AND HYDRAULIC SYSTEM OIL CASE IH AKCELA NEXPLORE	MAT 3525	API GL4 (SAE 10W-30) (ISO VG32/46)
FRONT AXLE (Axle and Hubs) CASE IH AKCELA NEXPLORE		
FRONT P.T.O GEARBOX OIL CASE IH AKCELA NEXPLORE		
ENGINE RADIATOR COOLANT CASE IH AKCELA PREMIUM ANTI-FREEZE (mixed with 50% of water)	MS 1710	Ethylene Glycol
BRAKE OIL CASE IH AKCELA LHM FLUID	n/a	ISO 7308
AIR CONDITIONING COMPRESSOR OIL Low Viscosity Oil SP10	n/a	PAG-E13 ISO100 Viscosity
GREASE FITTINGS AND BEARINGS CASE IH AKCELA MULTI-PURPOSE GREASE 251H EP	251H EP	NLGI2, Li-Ca

Regarding filling quantity - see **Capacities ()**

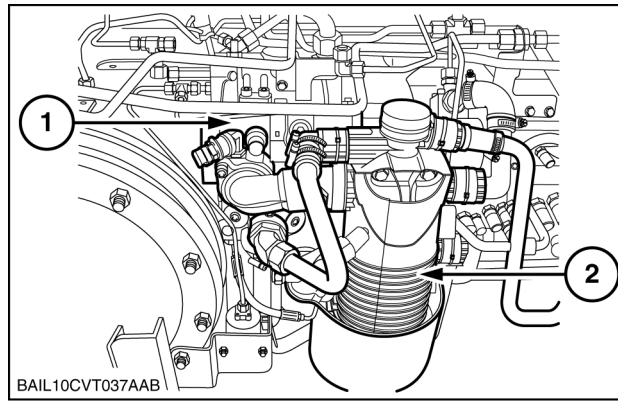

BAIL10CVT037AAB 2

The gear pump (1) Figure 3 supplies low pressure and lubrication oil.

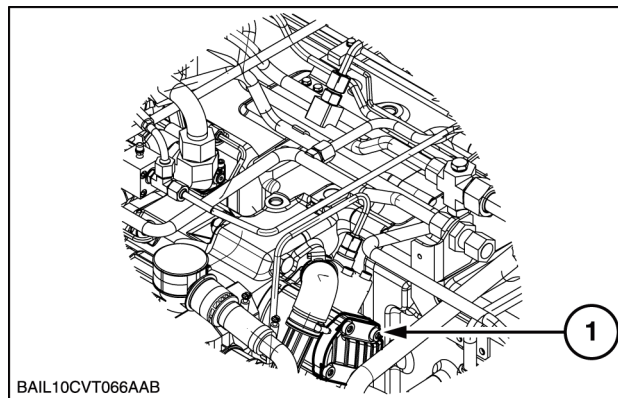

BAIL10CVT066AAB 3

Located on the right hand side of the rear axle housing is a resounding filter assembly.

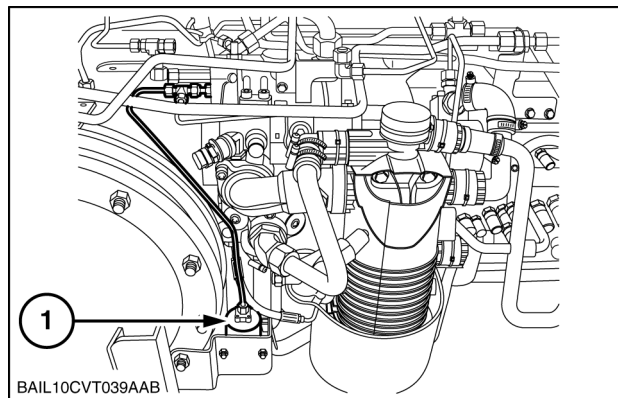

BAIL10CVT039AAB 4

The priority valve (1) located on the top of the main pump diverts high pressure oil to the steering, the trailer brake valve (where fitted) (2) and high pressure circuit. (Refer to **Priority valve - Dynamic description (A.14.A)**)

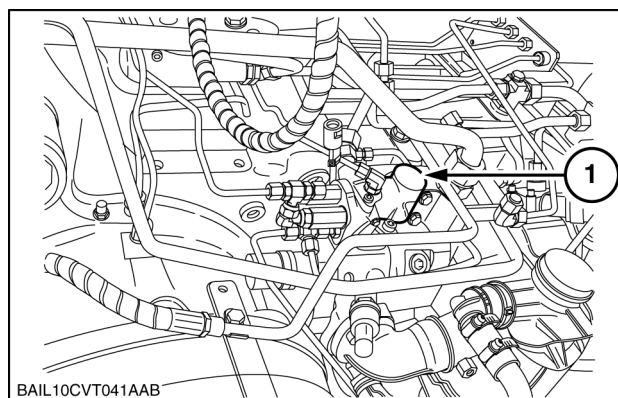

BAIL10CVT041AAB 5

Closed centre remote valves .

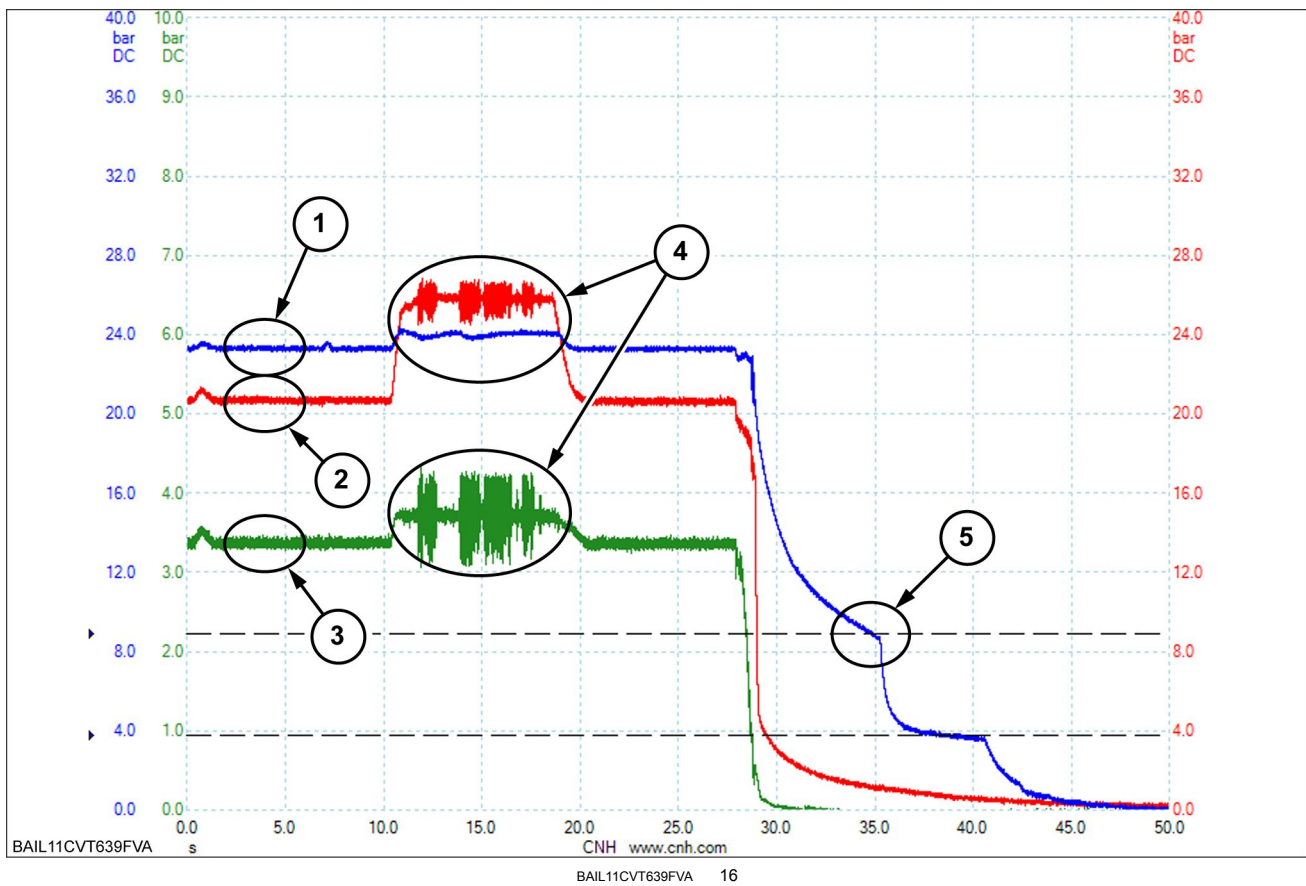

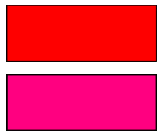

Pump Pressure



Return To reservoir

Load Sensing

- 1 Return to Reservoir
- 3 Parallel Supply Gallery
- 5 Remote Control Valve IV
- 7 Remote Control Valve II
- 9 Electronic Draft Control Valve
- 11 Return to Reservoir

- 2 Load sensing Gallery
- 4 End Cover
- 6 Remote Control Valve III
- 8 Remote Control Valve I
- 10 From Hydraulic Oil Pump
- 12 Load Sense Line

All valve sections have a common parallel inlet and return to reservoir gallery.

The load sensing gallery passes through the centre of the valve stack and signals the pump to increase or decrease output according to the demand.

The parallel gallery and load sensing system enables two or more valves to be operated simultaneously without loss of efficiency.

'O' ring seals (1) and load sense check valves (2) between each valve section ensure the highest circuit load sense pressure is transmitted to control the output of the hydraulic oil pump.

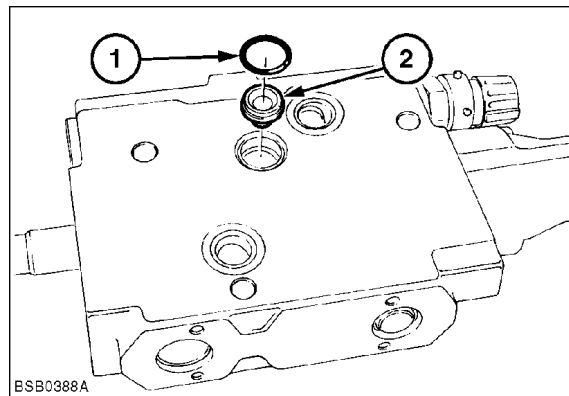

BSB0388A 8

The principal hydraulic components within each remote control valve section are:-

Flow Control Adjuster

The flow control adjuster is manually operated and adjusts oil flow through the remote valve. Turning the adjuster changes the size of the restriction in the path of oil flowing through the flow control spool.

Flow Control Spool

The flow control spool senses pressure differential across the restriction set by the flow control adjuster and regulates flow through the remote valve. Because each flow control spool individually senses the pressure differential in the remote valve being operated, two or more circuits working at different pressures can be controlled simultaneously.

Load Hold Check Valve

The load hold check valve prevents a back-flow of pressure from the remote valve circuit when the main control spool is operated and the hydraulic oil pump system pressure is less than the back-pressure in the circuit.

This is explained by the following example:-

Single Remote Valve Operating



Pump Pressure



Return to Reservoir



Remote Valve Operating Pressure



Trapped Oil

- | | | | |
|----|---|----|--|
| A. | Remote Valve in Operation | B. | Remote Valves in Neutral |
| 1. | Parallel Gallery (Interconnecting Remote Valves Sections) | 3. | Manually Adjusted Flow Control Restriction |
| 2. | Load Sense Line (Interconnecting Remote Valves Sections) | 4. | Spool Metering Lands |
| | | 5. | Flow Control Spool |
| | | 6. | Load Sense Line Check Valve |

PRIMARY HYDRAULIC POWER SYSTEM Electro-hydraulic remote valve - Sectional view

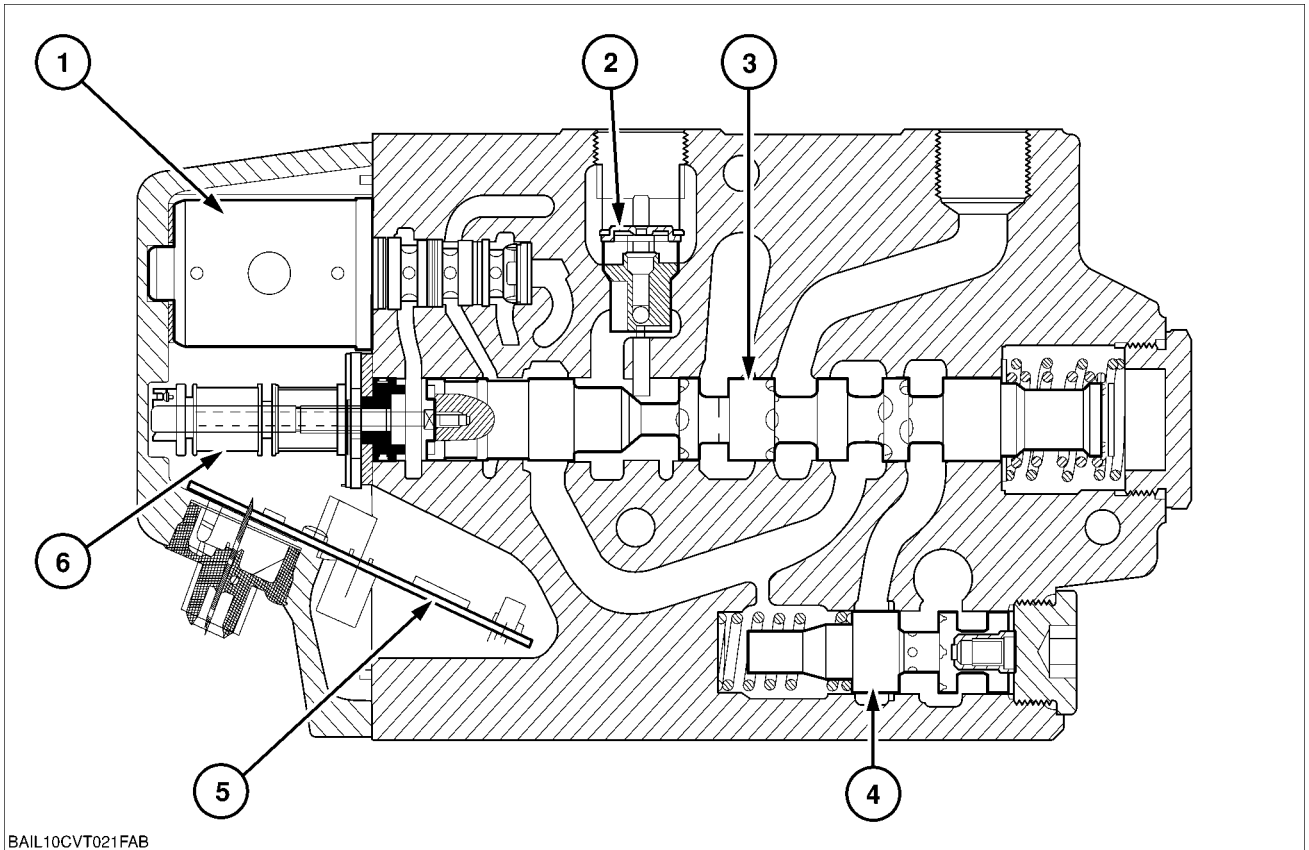

BAIL10CVT021FAB

BAIL10CVT021FAB 1

- | | |
|-------------------------|---------------------------------|
| 1. Solenoid | 2. Load holding check valve |
| 3. Control valve spool | 4. Flow control spool |
| 5. Micro processor unit | 6. Control spool operating coil |

6. Install the pneumatic trailer brake bracket assembly **(1)** (where fitted)

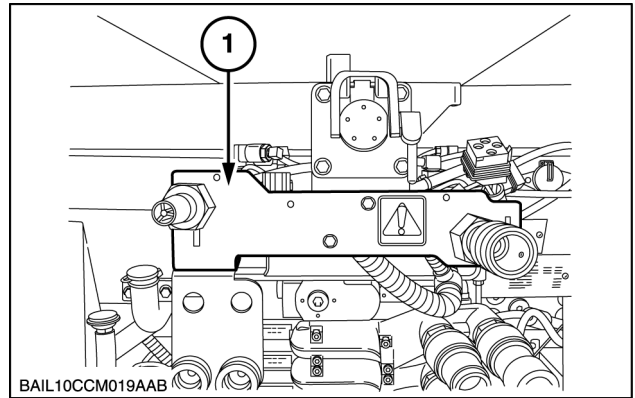

BAIL10CCM019AAB 4



**HYDRAULIC, PNEUMATIC, ELECTRICAL,
ELECTRONIC SYSTEMS - A**

PNEUMATIC SYSTEM - 20.A

**PUMA 130 CVX , PUMA 130 , PUMA 145 CVX , PUMA 145 , PUMA 160 CVX
, PUMA 160**

Component diagram 65	250
Component diagram 66	253
Component diagram 68	257
Component diagram 69	259
Component diagram 70	263
Component diagram 71	265
Component diagram 72	274
Component diagram 73	279
Component diagram 74	281
Component diagram 75	285
Component diagram 76	291
Component diagram 77	295
Component diagram 78	298
Component diagram 79	300
Component diagram 80	301
Component diagram 81	303
Component diagram 82	308
Component diagram 83	313
Component diagram 84	316
Component diagram 85	323
Component diagram 86	327
Component diagram 87 PUMA 130, PUMA 145, PUMA 160	330
Component diagram 88 PUMA 130, PUMA 145, PUMA 160	331
Component diagram 89	332
Component diagram 90	334
Component diagram 91	339
Component diagram 92	346
Component diagram 93	349
Component diagram 95	350
Component diagram 99	358
Wiring harness	
Static description	359
Electrical schema index	361
Electrical schema	373
Identification	374
Electrical schematic frame 01 POWER DISTRIBUTION (MAXI Fuses 1 - 6)	394
Electrical schematic frame 02 POWER DISTRIBUTION (Fuses 1 - 14)	396
Electrical schematic frame 03 POWER DISTRIBUTION (Fuses 15 - 21)	398
Electrical schematic frame 04 POWER DISTRIBUTION (Fuses 22 - 30)	400
Electrical schematic frame 05 POWER DISTRIBUTION (Fuses 31 - 45)	402
Electrical schematic frame 06 POWER DISTRIBUTION (Fuses 46 - 54)	404
Electrical schematic frame 07 POWER DISTRIBUTION (Fuses 55 - 60 / 91 - 92)	406

Connector - Component diagram 01

X011 Front and Rear Wiper Switch

POS.	COLOR	WIRE NUMBER	CIRCUIT REFERENCE
1	TN	1038	WINDSHIELD WIPER FEED-REAR
2	BK	57	EARTH (ALL)
3	LG	587	WINDSHIELD WIPER INTERMITTENT DELAY
5	RD	58	WIPER MOTOR-LOW
6	WH	56	WIPER MOTOR-HIGH
7	GN	1121	RR WINDSHIELD WASH
8	GN	1119	RR WINDSHIELD WIPER
9	LG	97	WINDSHIELD WASHER FEED
10	BL	63	WIPER MOTOR-PARK FEED

NOTE: For the wiring color code refer to, *Wiring harness - Identification (A.30.A)*.

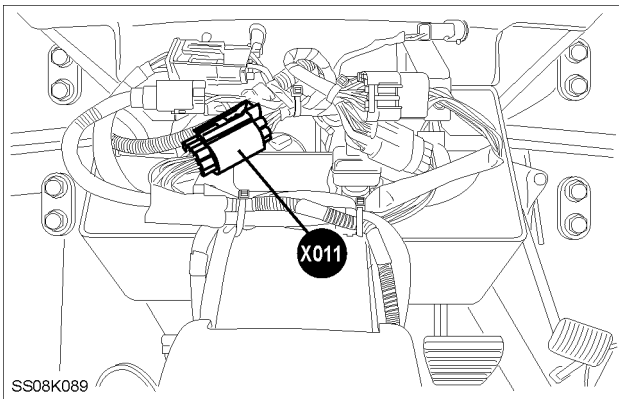

SS08K089 1

STEERING CONSOLE

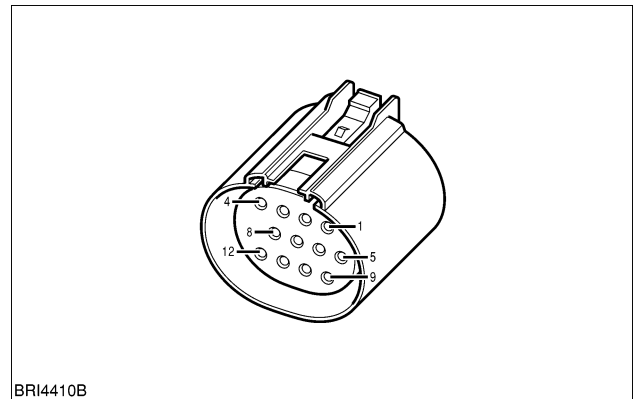

BRI4410B

BRI4410B 2

X033 Windscreen Wipers Front & Rear (K-001 / K-002)

POS.	COLOR	WIRE NUMBER	CIRCUIT REFERENCE
1	GN	1120	RR WINDSHIELD WIPER PARK RETURN
2	GN	1121	RR WINDSHIELD WASH
4	BK	57	EARTH (ALL)
5	GN	1119	RR WINDSHIELD WIPER
6	YE	28	WIPER MOTOR (PARK RETURN)
7	LG	587	WINDSHIELD WIPER INTERMITTENT DELAY
8	GN	1019	WINDSHIELD WIPER FEED
9	BK	57	EARTH (ALL)
10	BL	63	WIPER MOTOR-PARK FEED

NOTE: For the wiring color code refer to, **Wiring harness - Identification (A.30.A)**.

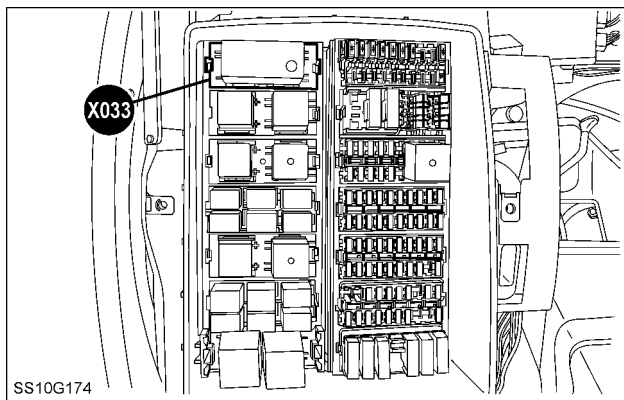

SS10G174 17

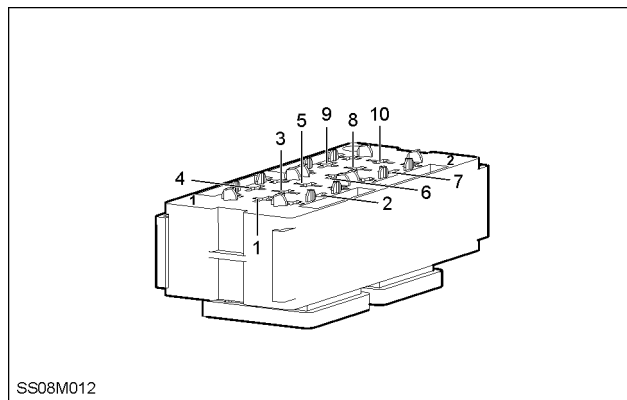

SS08M012 18

FRONT RIGHT HAND CAB

X086 Loader Valve 3

POS.	COLOR	WIRE NUMBER	CIRCUIT REFERENCE
1	BL	3277	LOADER VALVE #3 COIL
2	BL	3278	LOADER VALVE #3 RELAY

NOTE: For the wiring color code refer to, **Wiring harness - Identification (A.30.A)**.

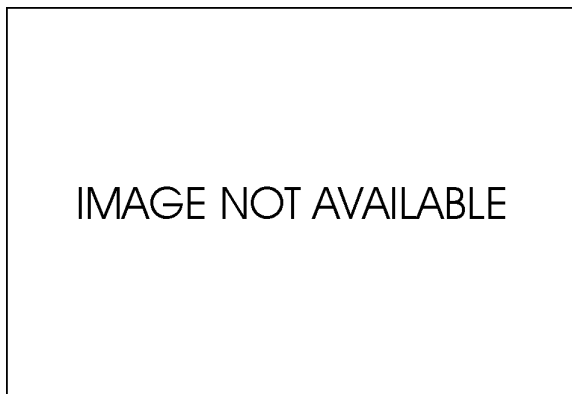

INA 15

CAB RIGHT HAND BEHIND OPERATOR'S SEAT

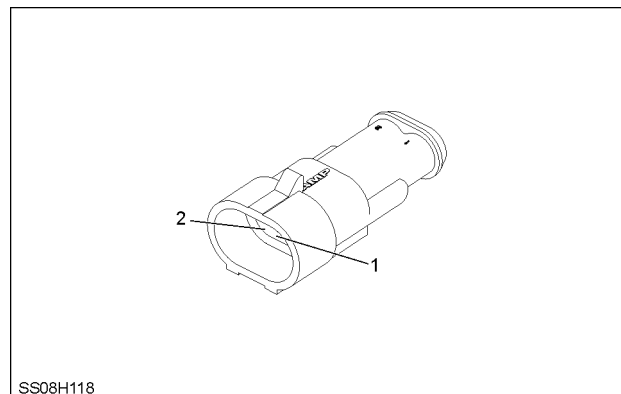

SS08H118

SS08H118 16

X158 Radio 1

POS.	COLOR	WIRE NUMBER	CIRCUIT REFERENCE
4	YE	3077	RADIO +12VB
6	OR	3078	RADIO +12V ILLUMINATION
7	RD	3079	RADIO +12V IGNITION
8	BK	57	EARTH (ALL)

NOTE: For the wiring color code refer to, **Wiring harness - Identification (A.30.A)**.

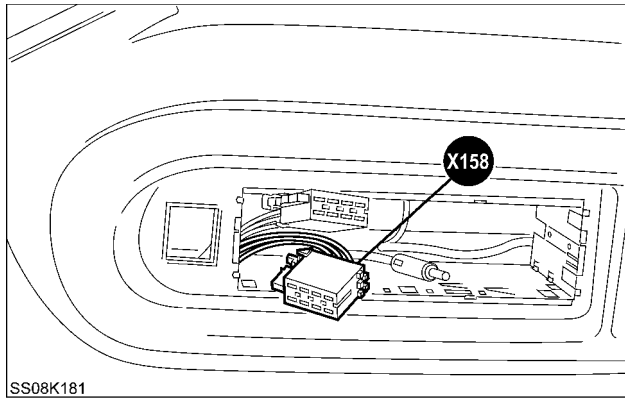

SS08K181 9

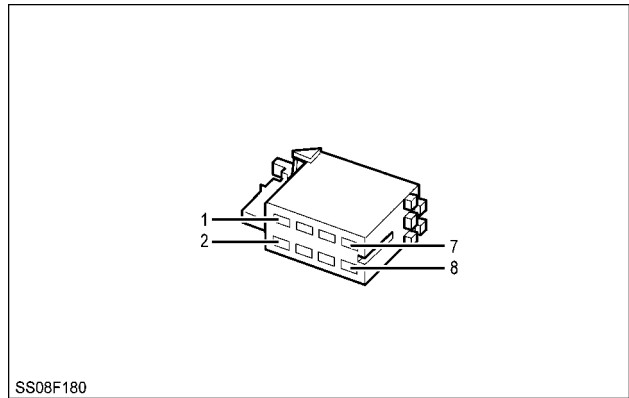

SS08F180 10

RIGHT HAND CAB ROOF

X214 Earth Point - Engine

POS.	COLOR	WIRE NUMBER	CIRCUIT REFERENCE
1	BK	57	EARTH (ALL)

NOTE: For the wiring color code refer to, *Wiring harness - Identification (A.30.A)*.

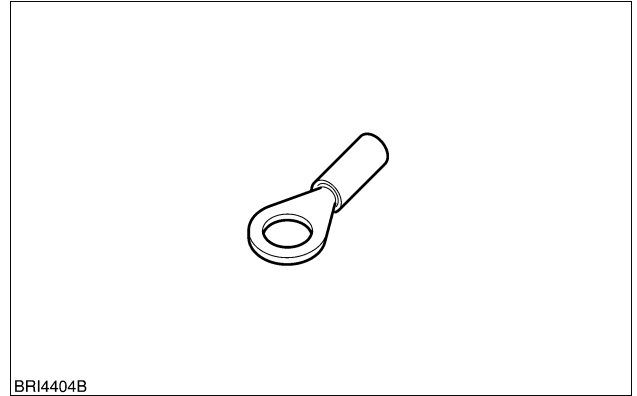
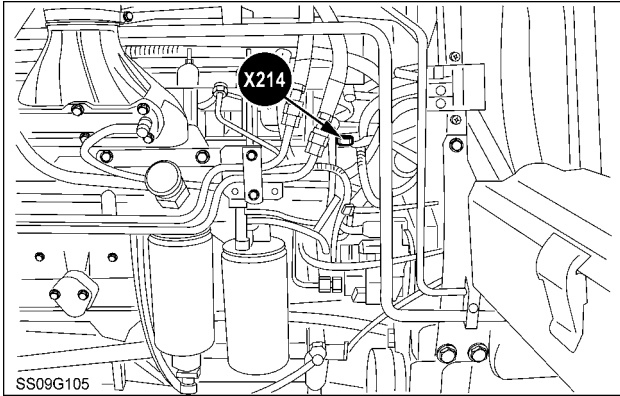

LEFT HAND ENGINE

X215 Grid Heater Relay

POS.	COLOR	WIRE NUMBER	CIRCUIT REFERENCE
1	VT	6586	ECU TO GRID HEATER RELAY RETURN
2	GN	6408	FUSED B+ TO ECU (1)

NOTE: For the wiring color code refer to, *Wiring harness - Identification (A.30.A)*.

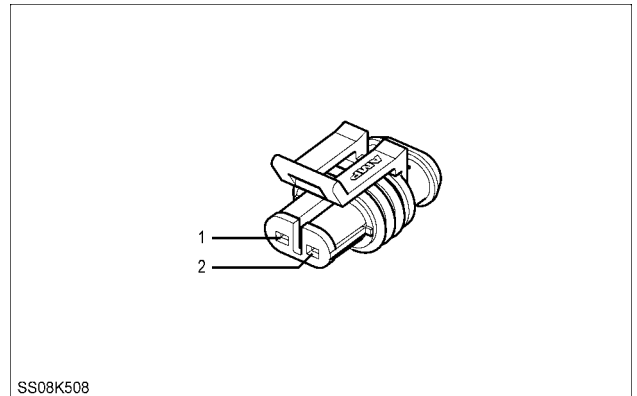
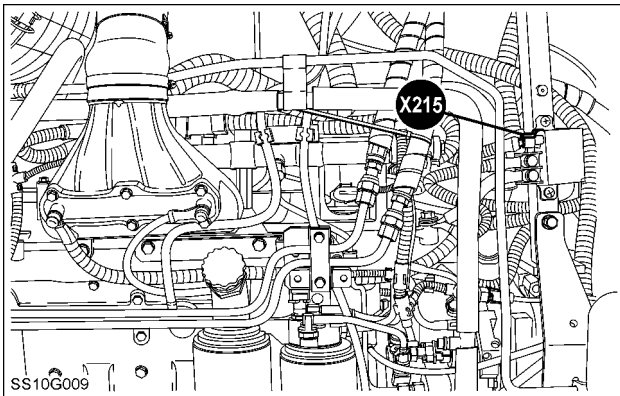

LEFT HAND ENGINE

X266 Draft PIN Left Hand

POS.	COLOR	WIRE NUMBER	CIRCUIT REFERENCE
1	BK/WH	60	SENSOR GROUND
2	TN	5070	EDC LEFT PIN
3	PK	5075	EDC VOLTAGE TO PINS

NOTE: For the wiring color code refer to, **Wiring harness - Identification (A.30.A)**.

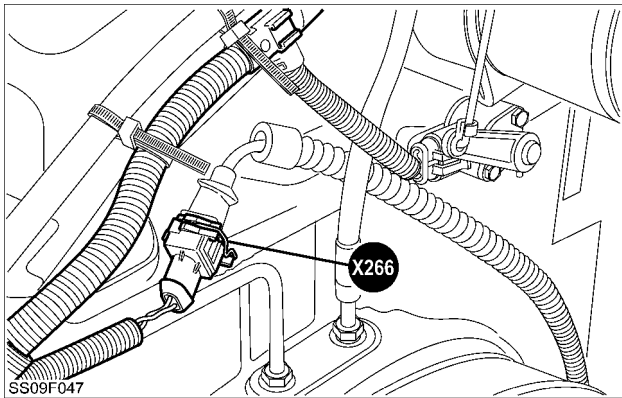

SS09F047 13

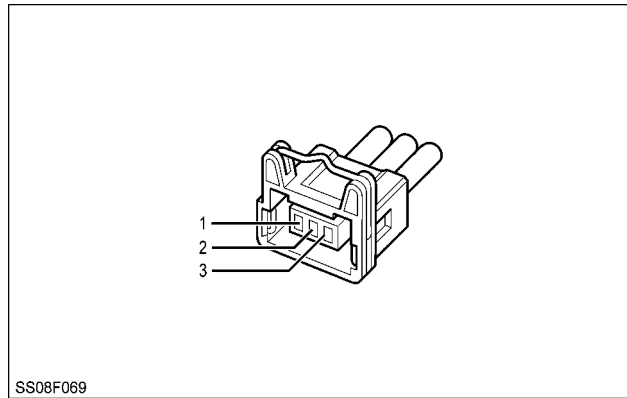

SS08F069 14

REAR LEFT HAND SIDE TRANSMISSION

X267 Rock Shaft Potentiometer

PUMA 130 CVX, PUMA 145 CVX, PUMA 160 CVX

POS.	COLOR	WIRE NUMBER	CIRCUIT REFERENCE
1	BK/WH	60	SENSOR GROUND
2	PK	5080	EDC ROCKSHAFT
3	TN	5020	EDC PROC +5V REF VOLTAGE DROP POSN/RATE

PUMA 130, PUMA 145, PUMA 160 - Semi / Full powershift

POS.	COLOR	WIRE NUMBER	CIRCUIT REFERENCE
1	BK/WH	60	SENSOR GROUND
2	PK	5080	EDC ROCKSHAFT
3	GN	5020	EDC PROC +5V REF VOLTAGE DROP POSN/RATE

NOTE: For the wiring color code refer to, **Wiring harness - Identification (A.30.A)**.

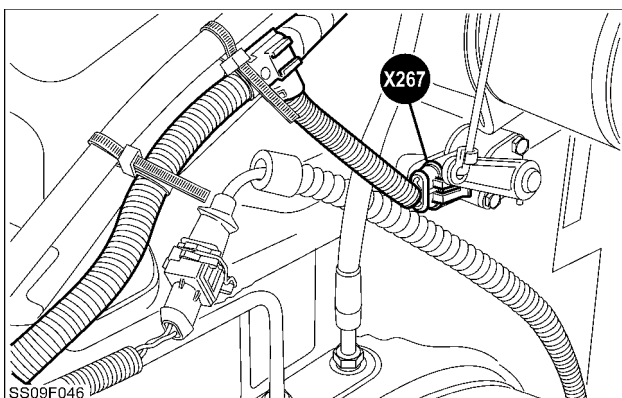

SS09F046 15

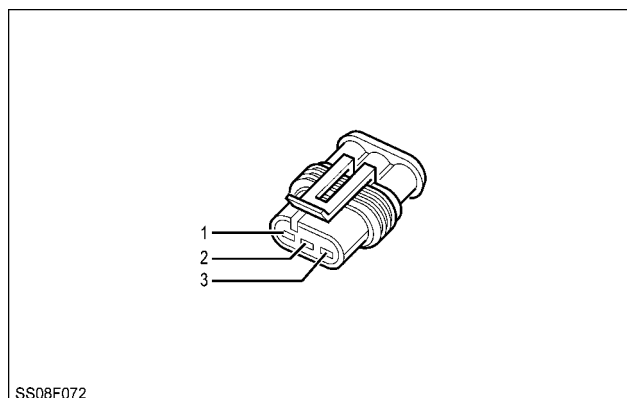

SS08F072 16

REAR RIGHT HAND SIDE TRANSMISSION

Connector - Component diagram 32

X321 Diverter Solenoid

POS.	COLOR	WIRE NUMBER	CIRCUIT REFERENCE
1	TN	9000	DIVERTER VALVE
2	BK	57	EARTH (ALL)

NOTE: For the wiring color code refer to, **Wiring harness - Identification (A.30.A)**.

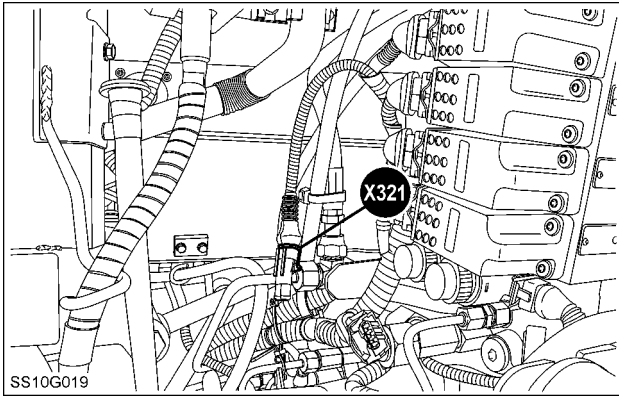

SS10G019 1

TOP OF REAR AXLE

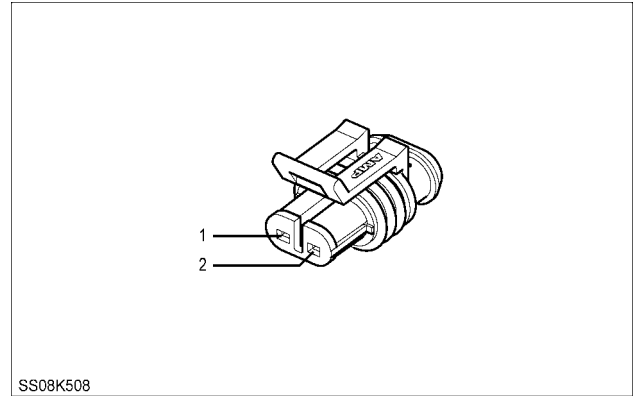

SS08K508 2

X326 Earth Transmission (Earth 1)

POS.	COLOR	WIRE NUMBER	CIRCUIT REFERENCE
1	WH	57	EARTH (ALL)
1	BK	57	EARTH (ALL)

NOTE: For the wiring color code refer to, **Wiring harness - Identification (A.30.A)**.

PUMA 130 CVX, PUMA 145 CVX, PUMA 160 CVX

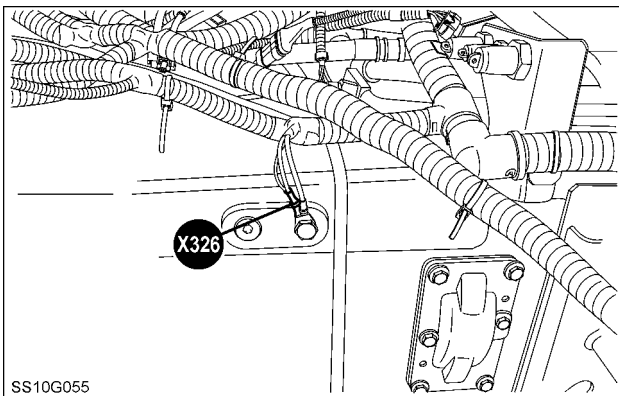

SS10G055 3

LEFT HAND TOP OF TRANSMISSION

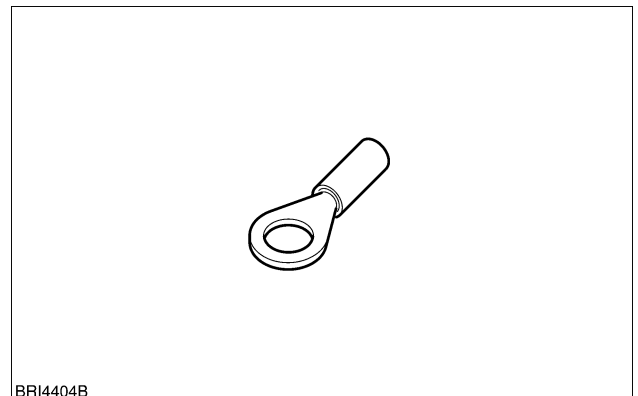

BRI4404B 4

PUMA 130, PUMA 145, PUMA 160 - Full powershift

Connector - Component diagram 43

X430 Air Brake (Pressure Sensor)

POS.	COLOR	WIRE NUMBER	CIRCUIT REFERENCE
1	TN	8010	TRAILER BRAKE PRESSURE
2	TN / PK	8020	TRAILER BRAKE PRESSURE
3	GN / BK	2095 / 57	EARTH (ALL)

NOTE: For the wiring color code refer to, *Wiring harness - Identification (A.30.A)*.

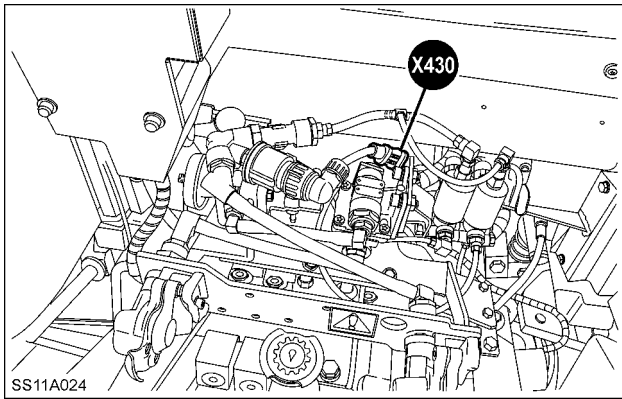

SS11A024 1

RIGHT HAND BY REAR AXLE

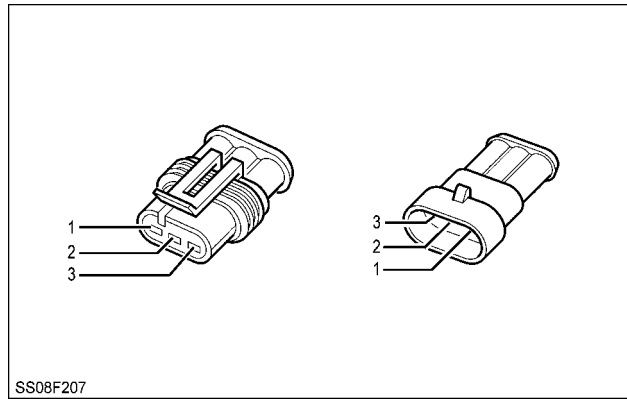

SS08F207 2

X431 Pneumatic Trailer Brake Solenoid

POS.	COLOR	WIRE NUMBER	CIRCUIT REFERENCE
1	BR	8000	TRAILER BRAKE SOLENOID
2	BK	57	EARTH (ALL)

NOTE: For the wiring color code refer to, *Wiring harness - Identification (A.30.A)*.

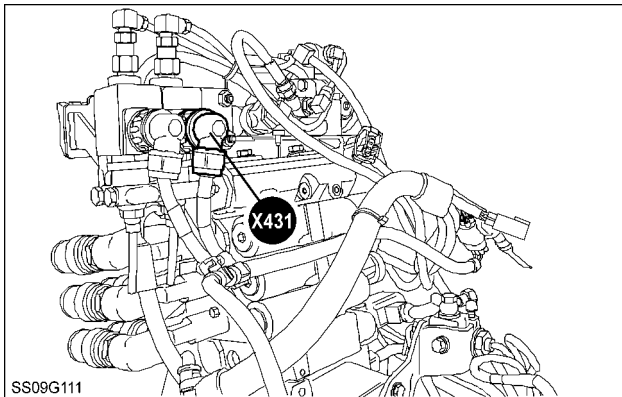

SS09G111 3

REAR OF TRACTOR BEHIND CAB

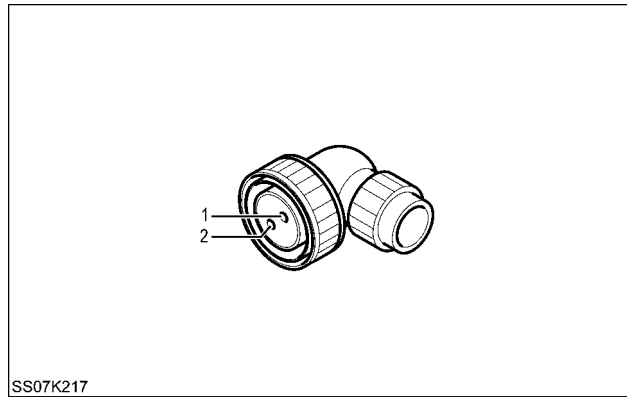

SS07K217 4

X545 Solenoid - Dump Valve

POS.	COLOR	WIRE NUMBER	CIRCUIT REFERENCE
1	TN	9035	50KPH DUMP SOLENOID
2	BK	57	EARTH (ALL)

NOTE: For the wiring color code refer to, **Wiring harness - Identification (A.30.A)**.

PUMA 130 CVX, PUMA 145 CVX, PUMA 160 CVX

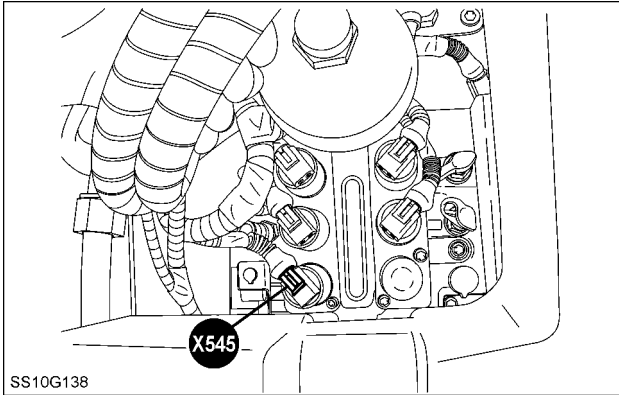

SS10G138 5

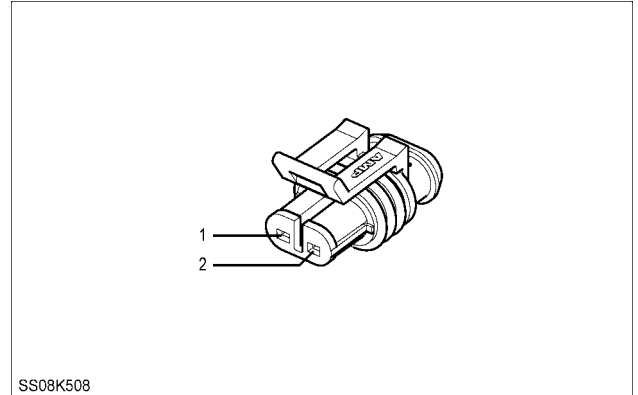

SS08K508 6

RIGHT HAND SIDE OF TRANSMISSION

X546 Clutch A Pressure Sensor

POS.	COLOR	WIRE NUMBER	CIRCUIT REFERENCE
A	BK/WH	60	SENSOR GROUND
B	TN	5020	EDC PROC +5V REF VOLTAGE DROP POSN/RATE
C	OR	7775	B CLUTCH PRESSURE SIGNAL

NOTE: For the wiring color code refer to, **Wiring harness - Identification (A.30.A)**.

PUMA 130 CVX, PUMA 145 CVX, PUMA 160 CVX

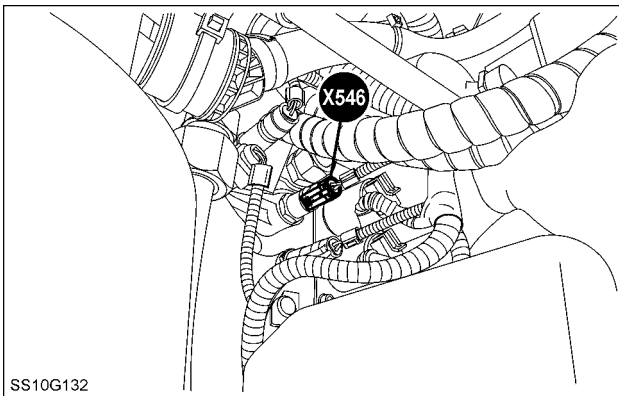

SS10G132 7

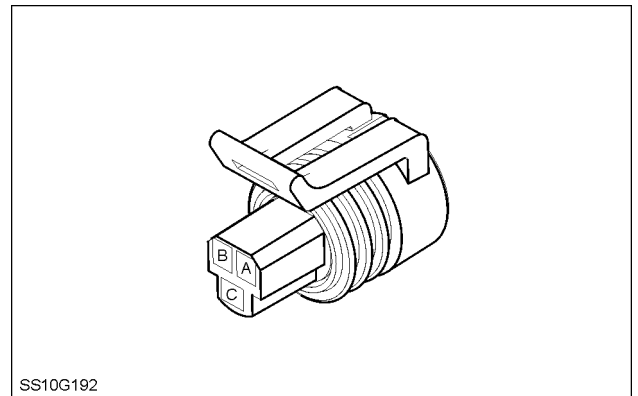

SS10G192 8

RIGHT HAND SIDE OF TRANSMISSION

X625 Fast Steer Steering Wheel Sensor

POS.	COLOR	WIRE NUMBER	CIRCUIT REFERENCE
2	VT	3172	FSS – STEERING PROXIMITY SENSOR POSITION
3	GN	10	IGNITION SUPPLY

NOTE: For the wiring color code refer to, *Wiring harness - Identification (A.30.A)*.

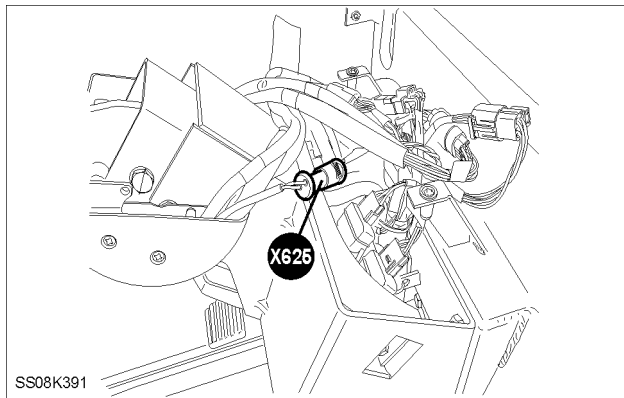

SS08K391 9

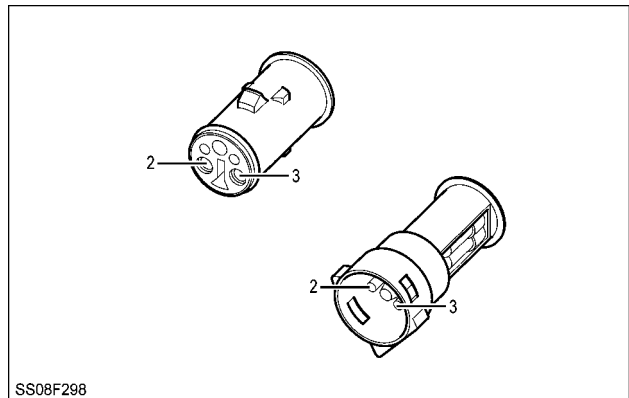

SS08F298 10

STEERING CONSOLE

X626 Fast Steer Split Valve Position Sensor (LVTD)

POS.	COLOR	WIRE NUMBER	CIRCUIT REFERENCE
1	BR	3179	FSS – POSITION SENSOR SECONDARY NEGATIVE
2	WH	3175	FSS – POSITION SENSOR PRIMARY POSITIVE
3	BL	3177	FSS – POSITION SENSOR SECONDARY COMMON
4	BK	3176	FSS – POSITION SENSOR PRIMARY NEGATIVE
5	GN	3178	FSS – POSITION SENSOR SECONDARY POSITIVE

NOTE: For the wiring color code refer to, *Wiring harness - Identification (A.30.A)*.

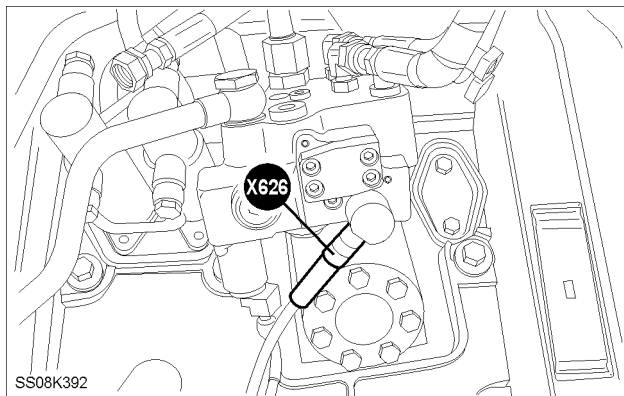

SS08K392 11

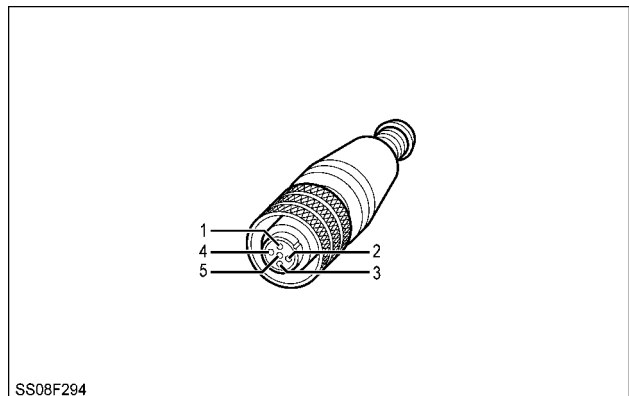

SS08F294 12

REAR OF ENGINE

Connector - Component diagram 68

X681 Hydraulics Master Switch

POS.	COLOR	WIRE NUMBER	CIRCUIT REFERENCE
1	OR	5210	EDC VALVE ENABLE
2	BL	7000	TRANS CONTROL SUPPLY
3	GY	5597	EHR MASTER ENABLE
5	GY	5835	HYDRAULIC MASTER SWITCH HIGH FLOW PUMP LINK
7	BK	57	EARTH (ALL)
8	RD	1012	ILLUMINATION
9	BK	57	EARTH (ALL)
10	RD	1012	ILLUMINATION

NOTE: For the wiring color code refer to, **Wiring harness - Identification (A.30.A)**.

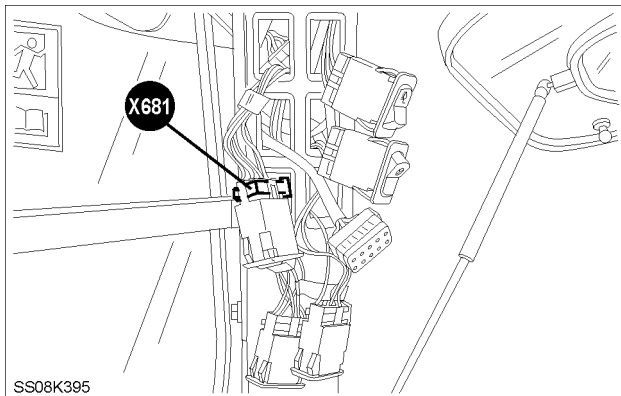

SS08K395 1

RIGHT HAND C PILLAR

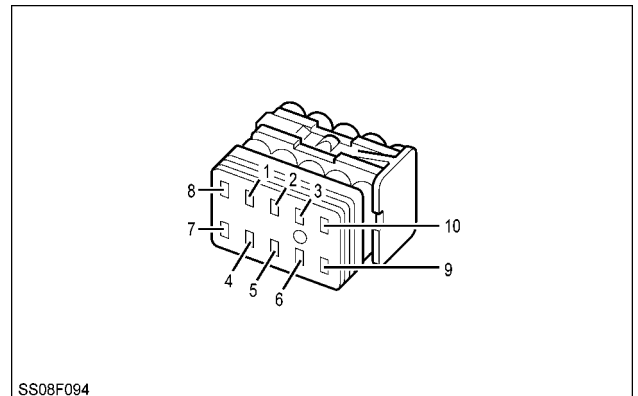

SS08F094

SS08F094 2

X739 Reversible Fan Compressor / Valve

POS.	COLOR	WIRE NUMBER	CIRCUIT REFERENCE
1	BR	6327	REVERSIBLE FAN RELAY POWER OUT
2	BK	57	EARTH (ALL)
3	BR	6327	REVERSIBLE FAN RELAY POWER OUT
4	BK	57	EARTH (ALL)

NOTE: For the wiring color code refer to, **Wiring harness - Identification (A.30.A)**.

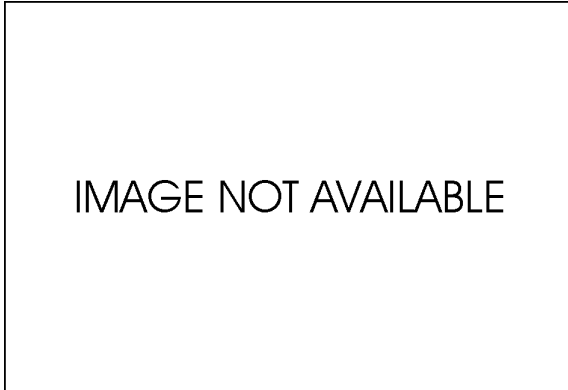

INA 5

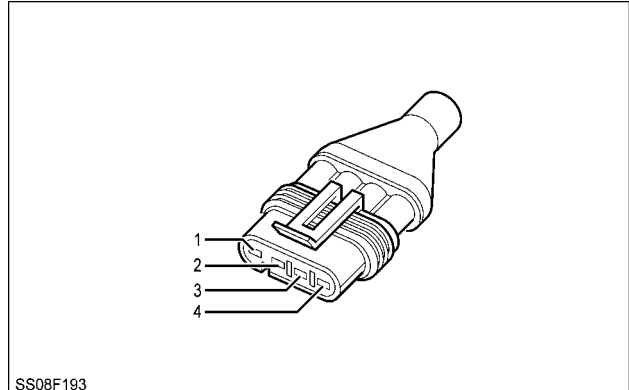

SS08F193

SS08F193 6

BEHIND RIGHT HAND C-PILLAR COVER

Connector - Component diagram 81

X810 Starter to Cabine (Ground)

POS.	COLOR	WIRE NUMBER	CIRCUIT REFERENCE
1	BK	57	EARTH (ALL)

NOTE: For the wiring color code refer to, *Wiring harness - Identification (A.30.A)*.

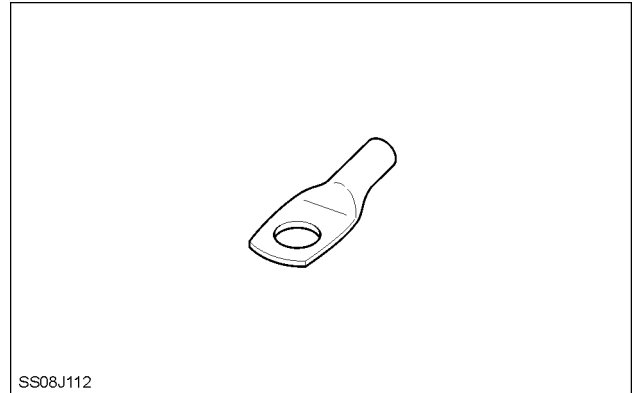
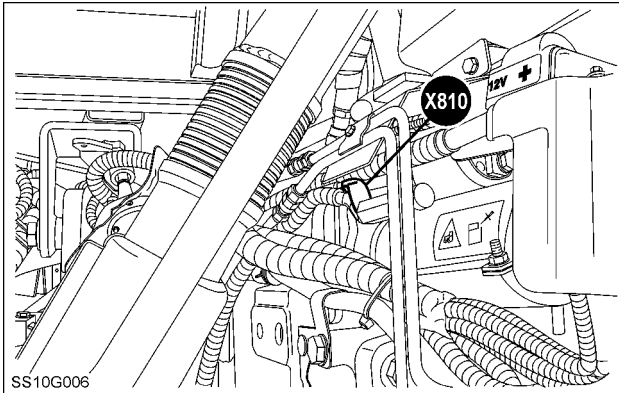

REAR LEFT HAND ENGINE

X811 Visctronic Engine Fan

POS.	COLOR	WIRE NUMBER	CIRCUIT REFERENCE
1	BR	6300	FAN SPEED
2	BK	57	EARTH (ALL)
3	BK	57	EARTH (ALL)
4	BR	6330	VISTRONIC FAN INPUT
5	BR	6320	FAN 5V REF.

NOTE: For the wiring color code refer to, *Wiring harness - Identification (A.30.A)*.

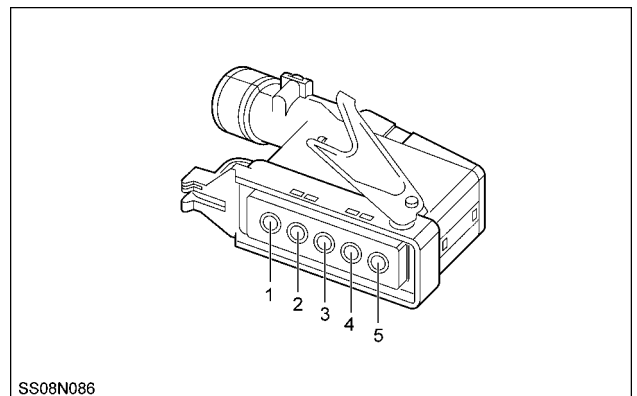
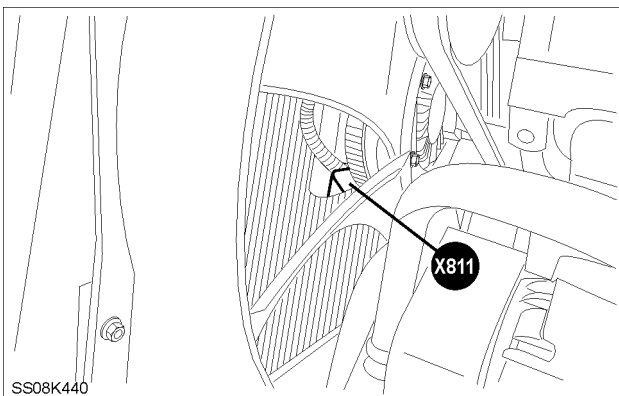

FRONT LEFT HAND ENGINE

X856 El.Hydraulic Remote Lamps 3 & 4 & Switch

POS.	COLOR	WIRE NUMBER	CIRCUIT REFERENCE
2	WH	-	EHR4 TIMER LED OUTPUT
3	WH	-	EHR4 MOTOR MODE LED OUTPUT
4	WH	-	EHR3 TIMER LED OUTPUT
5	WH	-	EHR3 MOTOR MODE LED OUTPUT
6	WH	-	LED POWER OUTPUT +12V
7	WH	-	EHR4 MOTOR / PROGRAM SWITCH
8	WH	-	EHR3 MOTOR / PROGRAM SWITCH

NOTE: For the wiring color code refer to, **Wiring harness - Identification (A.30.A)**.

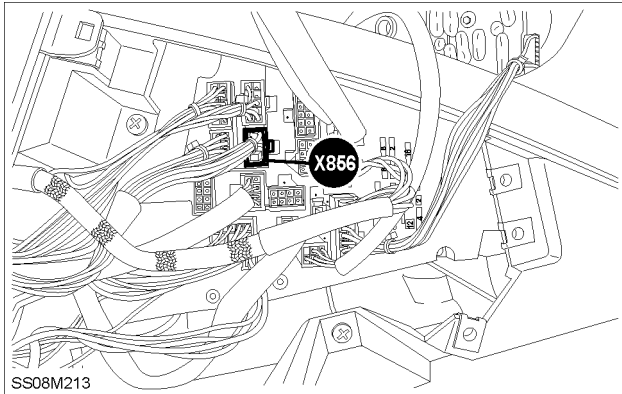

SS08M213 11

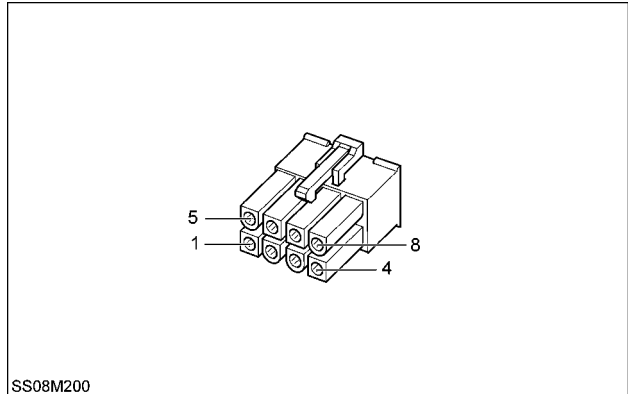

SS08M200 12

IN ARMREST

X859 El.Hydraulic Remote 1 & 2 Timer LED

POS.	COLOR	WIRE NUMBER	CIRCUIT REFERENCE
2	WH	-	EHR2 TIMER LED OUTPUT
3	WH	-	EHR2 MOTOR MODE LED OUTPUT
4	WH	-	EHR1 TIMER LED OUTPUT
5	WH	-	EHR1 MOTOR MODE LED OUTPUT
6	WH	-	LED POWER OUTPUT +12V
7	WH	-	EHR2 MOTOR / PROGRAM SWITCH
8	WH	-	EHR1 MOTOR / PROGRAM SWITCH

NOTE: For the wiring color code refer to, **Wiring harness - Identification (A.30.A)**.

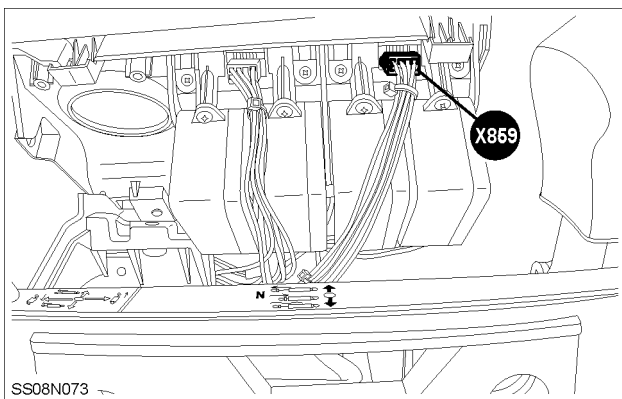

SS08N073 13

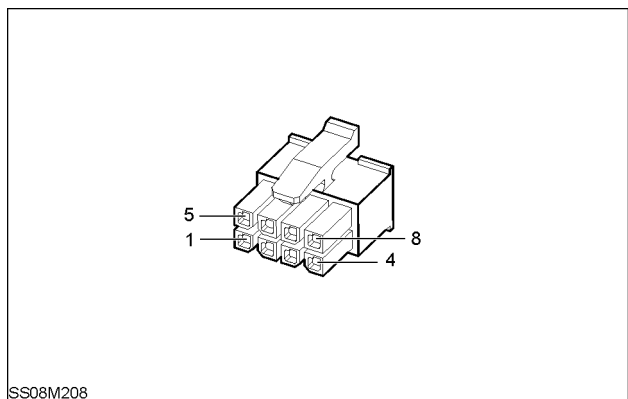

SS08M208 14

IN ARMREST

Connector - Component diagram 93

X936 SCR System Earth

POS.	COLOR	WIRE NUMBER	CIRCUIT REFERENCE
1	BK	57	EARTH (ALL)

NOTE: For the wiring color code refer to, **Wiring harness - Identification (A.30.A)**.

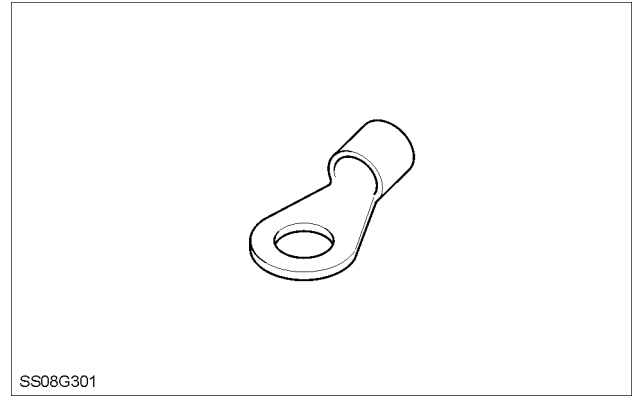
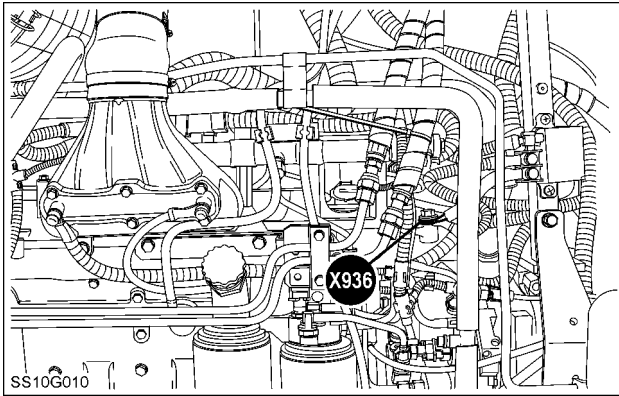

REAR LEFT HAND ENGINE

Code	Description	Frame
Y-069	Diverter Solenoid	Wiring harness - Electrical schematic frame 25 (A.30.A)
Y-070	Front Solenoid Valve Remote	Wiring harness - Electrical schematic frame 21 (A.30.A)
Y-082	Air Condition Clutch	Wiring harness - Electrical schematic frame 29 (A.30.A) Wiring harness - Electrical schematic frame 30 (A.30.A)
Y-083	Solenoid Valve Hydrostat	Wiring harness - Electrical schematic frame 15 (A.30.A)

ASSEMBLY

Code	Description	Frame
Z-001	Blower Assembly	Wiring harness - Electrical schematic frame 29 (A.30.A)
Z-002	Maxi Fuseholder	Wiring harness - Electrical schematic frame 32 (A.30.A)
Z-003	El.Hydraulic Remote Lamps 1 & 2 & Switch	Wiring harness - Electrical schematic frame 26 (A.30.A)
Z-004	El.Hydraulic Remote Lamps 3 & 4 & Switch	Wiring harness - Electrical schematic frame 26 (A.30.A)
Z-006	Diode Block	Wiring harness - Electrical schematic frame 37 (A.30.A) Wiring harness - Electrical schematic frame 40 (A.30.A)
Z-007	Joystick 2	Wiring harness - Electrical schematic frame 25 (A.30.A)
Z-010	Reversible Fan Compressor / Valve	Wiring harness - Electrical schematic frame 12 (A.30.A)
Z-011	Joystick 1	Wiring harness - Electrical schematic frame 25 (A.30.A)
Z-013	Dual Throttle	Wiring harness - Electrical schematic frame 25 (A.30.A)
Z-032	Multi Function Handle	Wiring harness - Electrical schematic frame 25 (A.30.A)
Z-038	Electric Mirror Right Hand	Wiring harness - Electrical schematic frame 31 (A.30.A)
Z-039	Electric Mirror Left Hand	Wiring harness - Electrical schematic frame 31 (A.30.A)
Z-043	Front Hitch Setting	Wiring harness - Electrical schematic frame 25 (A.30.A)
Z-044	Rear Hitch Setting	Wiring harness - Electrical schematic frame 25 (A.30.A)
Z-062	Shuttle Lever	Wiring harness - Electrical schematic frame 16 (A.30.A)
Z-065	Seat Assembly	Wiring harness - Electrical schematic frame 18 (A.30.A)
Z-069	Air Condition Assembly	Wiring harness - Electrical schematic frame 29 (A.30.A)
Z-070	EDC Mouse	Wiring harness - Electrical schematic frame 25 (A.30.A)
Z-071	Droop Potentiometer	Wiring harness - Electrical schematic frame 25 (A.30.A)

Alternator - Preliminary test

CAUTION - Service Precautions

To avoid damage to the components of the alternator charging system, service precautions must be observed as follows:

- NEVER make or break any of the charging circuit connections, including the battery, when the engine is running.
- NEVER short any of the charging components to ground.
- ALWAYS disconnect the battery ground cable (negative) when charging the battery on the tractor using a battery charger.
- ALWAYS observe correct polarity when installing the battery or using a slave battery to start the engine.

NOTICE: ALWAYS CONNECT POSITIVE TO POSITIVE AND NEGATIVE TO NEGATIVE.

Preliminary Checks

Prior to electrical testing thoroughly inspect the charging and electrical system.

Check all leads and connections for continuity and tightness.

1. Check the battery state of charge.

Using a hydrometer check the individual battery cells. The battery should be at least **70 %** charged and in good condition.

2. Check the drive belt.

Inspect the alternator drive belt and pulley, ensuring that both are clean, free from oil and grease and in good condition.

The alternator drive belt is automatically tensioned by a spring tensioner mounted at the front of the engine, refer to **Alternator - Static description (A.30.A)**. If the belt tension is suspect, check the tensioner assembly as follows:

Remove the fan belt, for further information refer to **Fan and drive Belt - Remove (B.50.A)**.

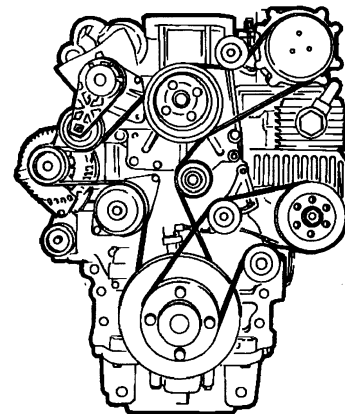

3SE2983A

BSE2983A 1

Inspection and Repair

1. Checking of the tensioner assembly operation should be carried out, with the tensioner assembly still attached to the front of the engine. To check the spring load, place a "breakback" torque bar preset to, **52 - 63 lbf.ft (70 - 85 Nm) (7.1 - 8.7 kgf.m)**, onto the pulley arm **15 mm** socket. Raise the lever up through an arc of **20 °** maximum. If the torque bar does not "break" within the range, install a new fan belt tensioner. For further information refer to **Fan and drive Belt tensioner - Remove (B.50.A)**
Ensure the tensioner pulley rotates freely by hand. If it does not rotate freely by hand, install a new fan belt tensioner. For further information refer to **Fan and drive Belt tensioner - Remove (B.50.A)**
2. Re-Assembly
To install the fan belt tensioner, refer to **Fan and drive Belt tensioner - Install (B.50.A)**.
Install the fan belt. For further information, refer to **Fan and drive Belt - Install (B.50.A)**

Code	Description
2009	Seat switch input – voltage too low
2010	Seat switch input – voltage too high
2011	Clutch pedal potentiometer – voltage too low
2012	Clutch pedal potentiometer – voltage too high
2021	Transmission harness disconnected
2024	All clutches not calibrated
2025	Synchronisers not calibrated
2026	Engine speed – too high
2027	Engine speed – no signal
2035	Dump solenoid – short to 12V
2036	Dump solenoid – short to ground or open circuit
2037	Clutch pedal disconnect switch – open circuit
2047	Clutch pedal disconnect switch set too high
2048	Clutch pedal disconnect switch set too low
2049	Wheel speed (transmission output speed) sensor – short to ground or open circuit
2050	Wheel speed (transmission output speed) sensor – short to 12V
2051	Oil temperature sensor – open circuit
2052	Oil temperature sensor – short circuit
2055	Wheel speed (transmission output speed) sensor – no signal
2059	Shuttle lever switch disagreement ("N" displayed)
2070	Shuttle lever forward switch – voltage too high
2071	Shuttle lever forward switch – voltage too low
2072	Shuttle lever reverse switch – voltage too high
2073	Shuttle lever reverse switch – voltage too low
2075	Flywheel speed sensor signal error
2076	Flywheel speed sensor – open circuit
2077	Flywheel speed sensor – short circuit
2079	Flywheel speed sensor – no signal
2110	Shuttle lever neutral switch - voltage too low
2111	Shuttle lever neutral switch - voltage too high
2124	Flywheel speed sensor not calibrated
2303	Damper calibration – low error
2304	Damper calibration – high error
2331	Clutch slipping fault (CP displayed)
2342	Clutch A solenoid – open circuit or short circuit to ground
2343	Clutch B solenoid – open circuit or short circuit to ground
2352	Clutch A solenoid – voltage too high
2353	Clutch B solenoid – voltage too high
2362	Clutch A not calibrated
2363	Clutch B not calibrated
2380	Parklock – unable to reach desired position
2381	Parklock – bus off
2382	Parklock – bus integrity error
2500	Input over speed error
2501	Oil pressure sensor – open circuit or short circuit to ground
2502	Oil pressure sensor – short circuit to +5V
2503	Clutch A solenoid – in use, an open circuit or short circuit to ground
2504	Clutch B solenoid – in use, an open circuit or short circuit to ground
2505	Clutch A pressure not plausible (mismatch between clutch A pressure and solenoid current)
2506	Clutch B pressure not plausible (mismatch between clutch B pressure and solenoid current)
2517	F2/R1 synchro potentiometer – signal too high
2518	F2/R1 synchro potentiometer – signal too low
2519	Synchro not moving towards F2
2520	Synchro not moving towards R1
2521	F2 solenoid - open circuit or short circuit to ground

Control module Instrument controller - H3 - Configurations and options

This menu displays the configurations available for:

- Engine shutdown
- Error code reduction
- Steering sensor selection
- Air brake selection
- 2nd fuel tank selection
- SWCD selection

H3 Menu Screen Select Diagram

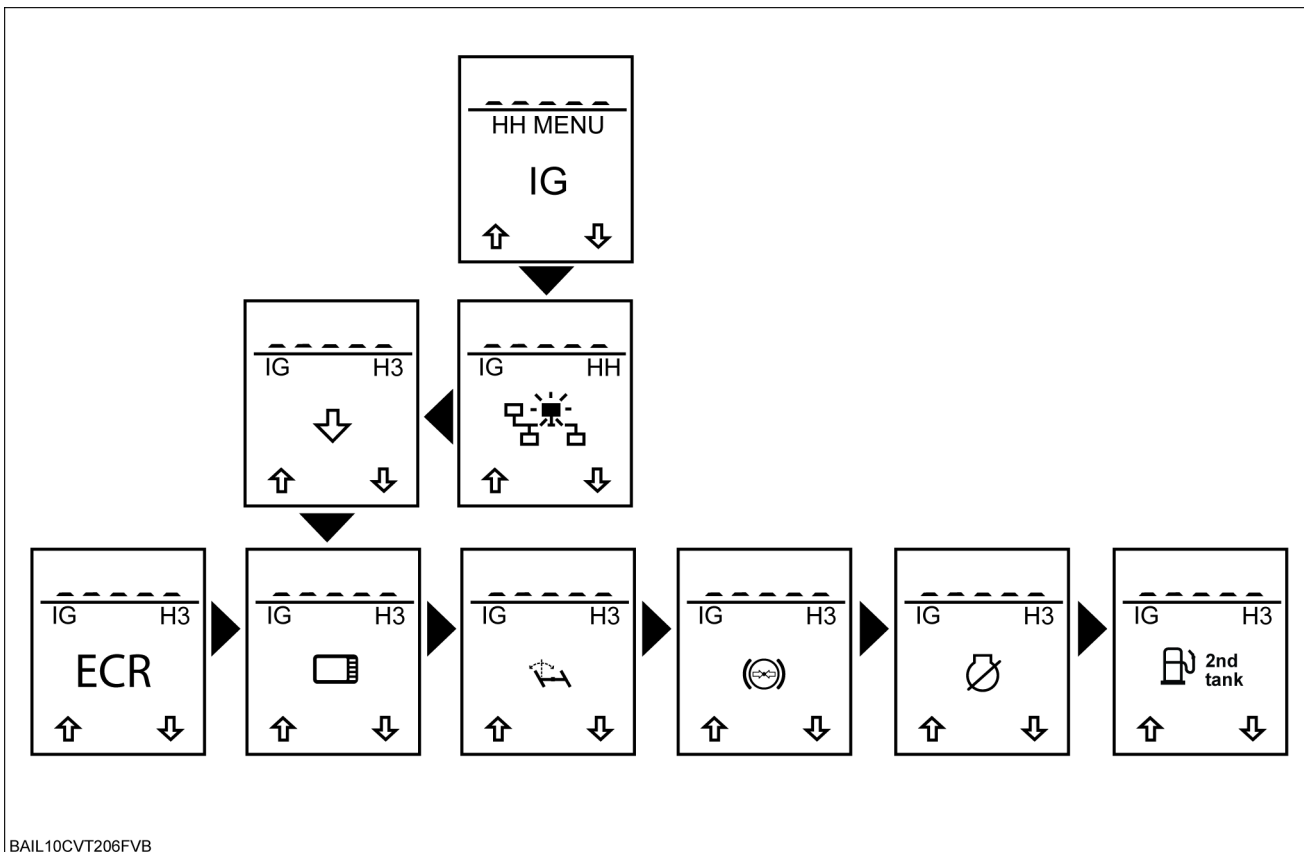

BAIL10CVT206FVB

BAIL10CVT206FVB 1

Engine Shutdown Options

Select the engine shutdown sub-system by pressing the "menu" key.

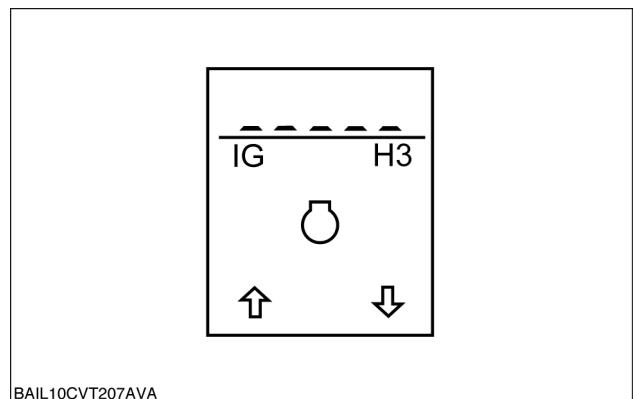

BAIL10CVT207AVA

BAIL10CVT207AVA 2

EDC Position Sensor Calibration

NOTE: This procedure is required, prior to calibration of the EDC valve. If fault code 1024 is displayed the position sensor calibration has not been carried out.

NOTE: This calibration is not carried out using the "H menu" system.

NOTE: The calibration procedure is controlled by the electronic management system. To prevent inadvertent movement of the tractor, park the tractor away from any obstacles, firmly apply the parking brake and block the wheels, front and rear. Check that the ground speed display is zero before commencing.

Remove any load from the hitch and make sure that the Automatic Pick Up Hitch (APUH) lift rods, if fitted are disconnected.

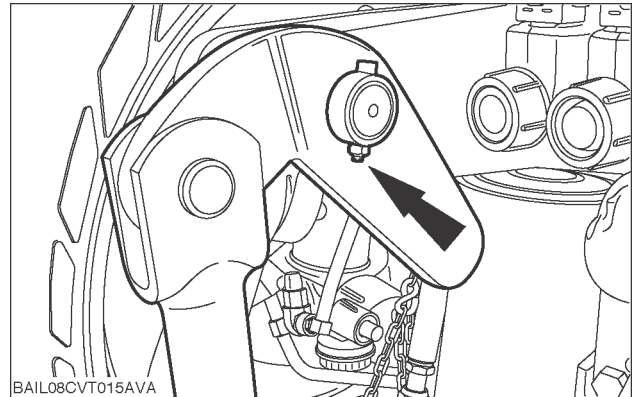

BAIL08CVT015AVA

BAIL08CVT015AVA 15

Erase the previously stored calibration value by pressing and holding the fast raise switch on the hand controller and turning the ignition switch to the 'ON' position. Release the fast raise switch and turn off the ignition.

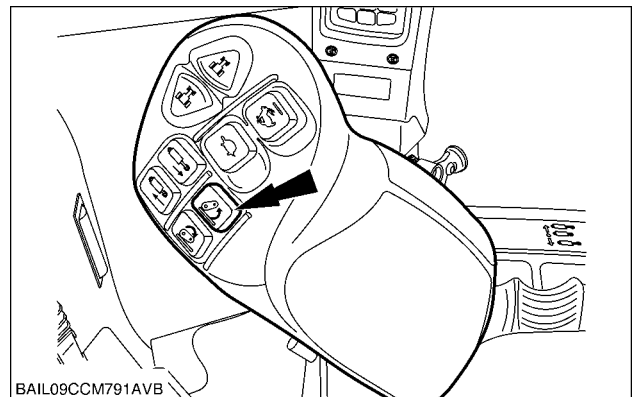

BAIL09CCM791AVB

BAIL09CCM791AVB 16

Make sure that the correct lift ram size has been set, refer to the H3 'options and configurations' menu, **Control module Universal controller - H3 - Configurations and options (A.50.A)**, if no ram size is configured fault code 1070 will be displayed.

Make sure that the height limit control is in the fully clockwise position. Fault code 1068 will be displayed if the control is not fully clockwise.

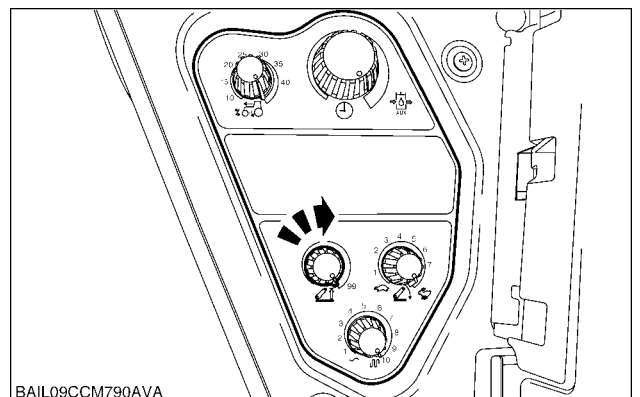

BAIL09CCM790AVA

BAIL09CCM790AVA 17

H3 Menu Screen Select Diagram

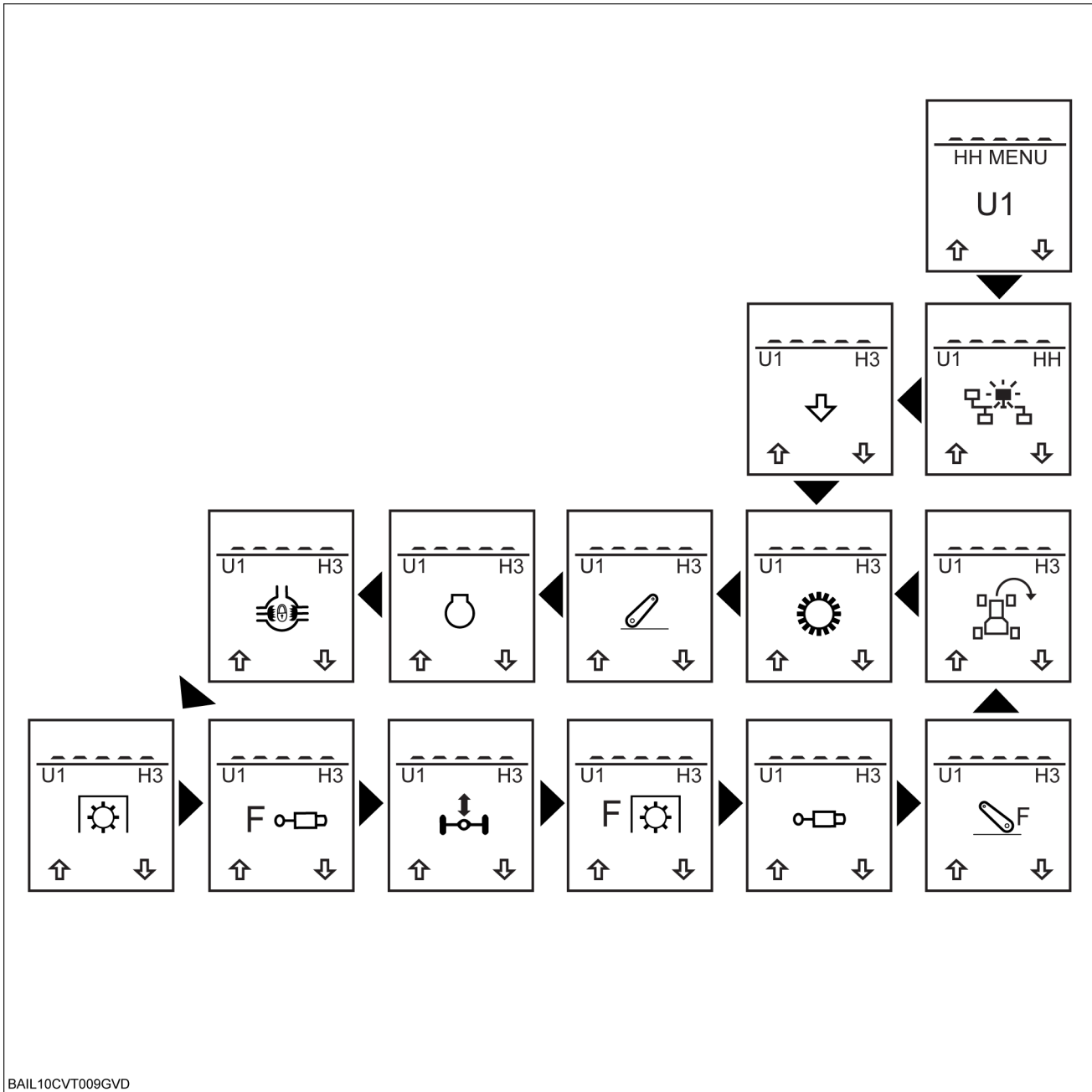

BAIL10CVT009GVD

BAIL10CVT009GVD 1

Transmission Options

Use the "up", "down", and the "menu" keys to navigate the HH menus to H3 and the transmission symbol on the U1 controller.

The upper section of the display will show "Ch_ _"

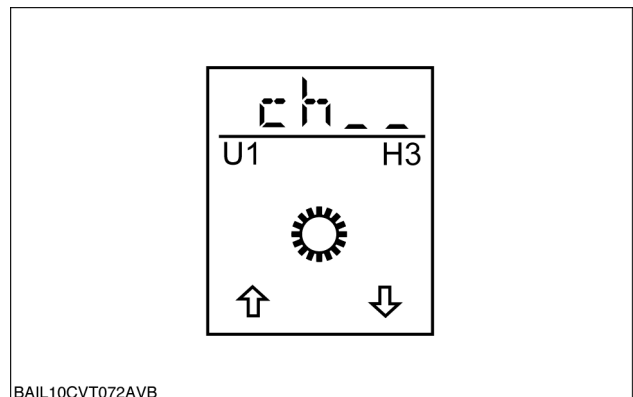

BAIL10CVT072AVB

BAIL10CVT072AVB 2

The upper section of the display will automatically cycle through the software release, as the example shown and return to allow navigation of the "HH" menus.

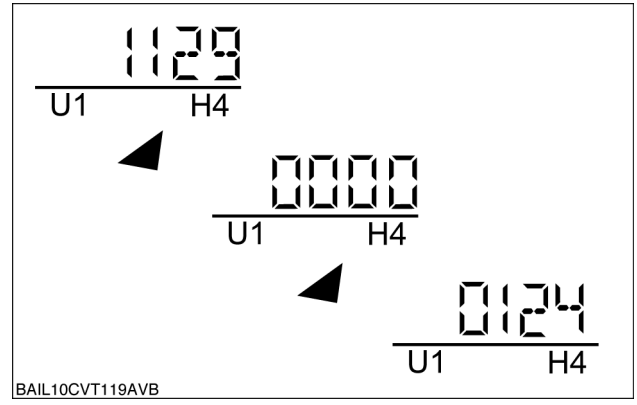

BAIL10CVT119AVB 3

Select the required sub-system by depressing the "menu" key.

The upper section of the display will show "___", if no fault codes are stored.

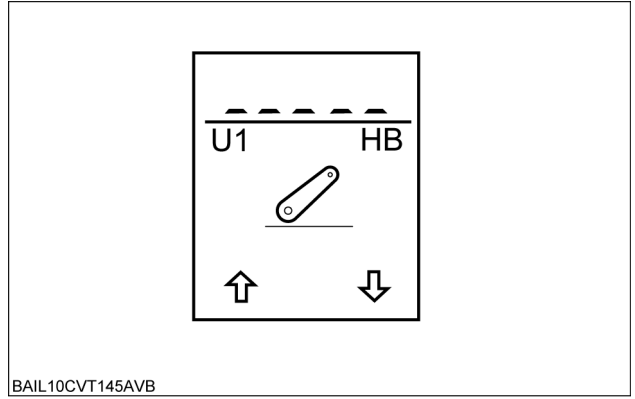

BAIL10CVT145AVB

BAIL10CVT145AVB 2

The upper section of the display will show "F", if any fault codes are stored.

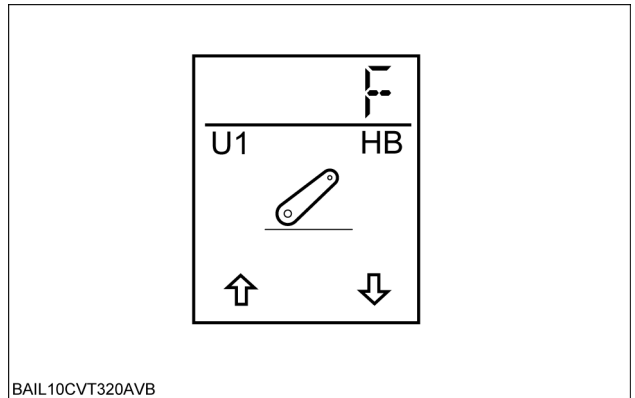

BAIL10CVT320AVB

BAIL10CVT320AVB 3

The display will then automatically cycle through as the example:

- 1002 Fault code
- 137 Hour of first occurrence
- 149 Hour of last occurrence
- 5 Number of occurrences of the fault

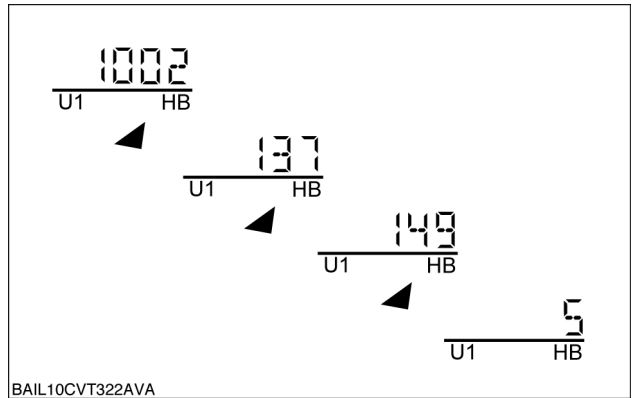

BAIL10CVT322AVA

BAIL10CVT322AVA 4

Depress the "up" or "down" key to change to the next fault code in the list.

The upper section of the display will display "___", at the end of the list.

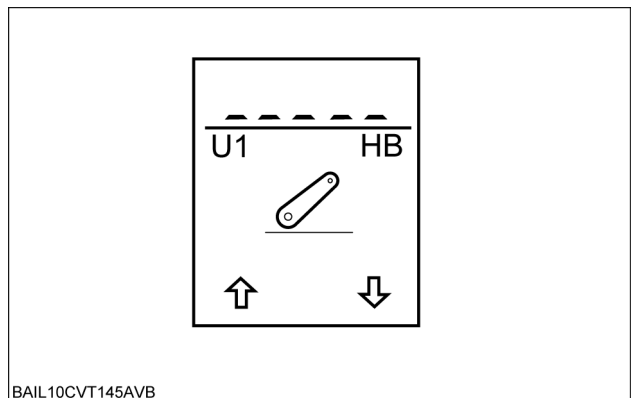

BAIL10CVT145AVB

BAIL10CVT145AVB 5

Use the "up" and "down" keysto toggle between the available options:

- "Pro" - proximity sensor
- "Lvd t" - LVDT sensor
- "deF" - adopt the default values

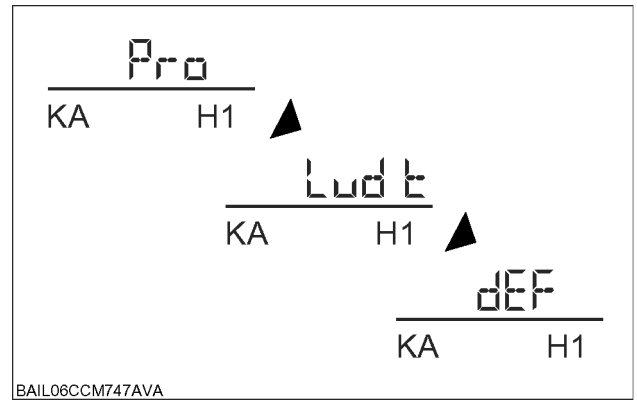

BAIL06CCM747AVA

BAIL06CCM747AVA 3

Set the engine speed to **1300 RPM**.

Proximity Sensor Calibration

Select the "Pro" option by depressing the "menu" key.

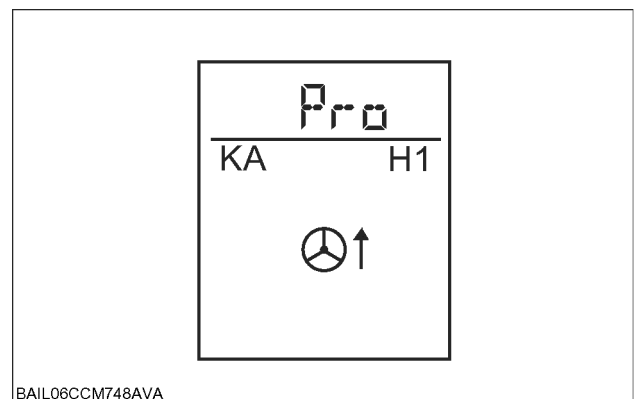

BAIL06CCM748AVA

BAIL06CCM748AVA 4

The top section of the display will show "0 _ _ _" for the steering wheel in the disengaged position.

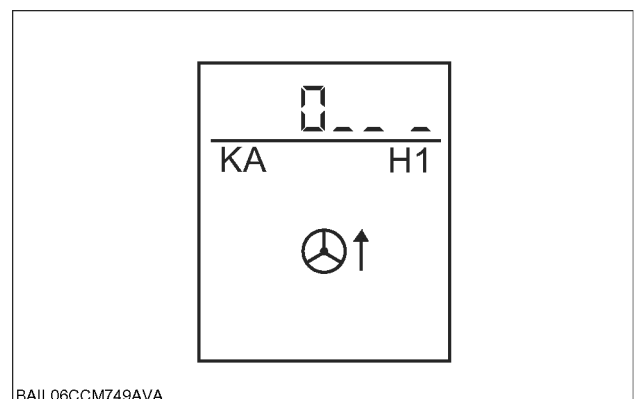

BAIL06CCM749AVA

BAIL06CCM749AVA 5

Depress and hold the "down" key. When the signal has been stable for 2 seconds an audible bleep will be heard and the display will change to "0 xxx". "xxx" is the digital reading of the sensor voltage when the steering wheel is in the disengaged position.

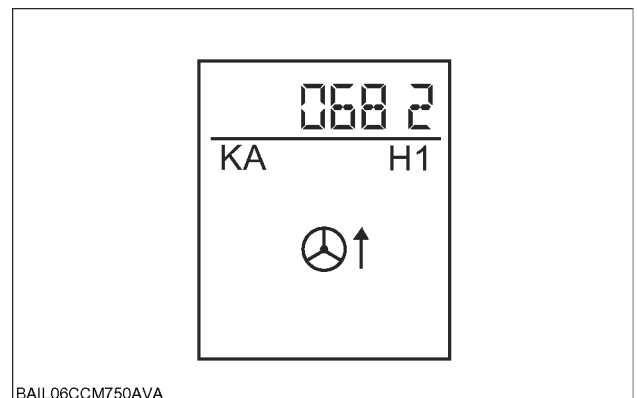

BAIL06CCM750AVA

BAIL06CCM750AVA 6

Control module Electronic park lock (EPL) controller - H2 - View stored calibration values

NOTE: This menu is used to display the calibration values stored in the controller for the Electronic Park Lock

H2 Menu Screen Select Diagram

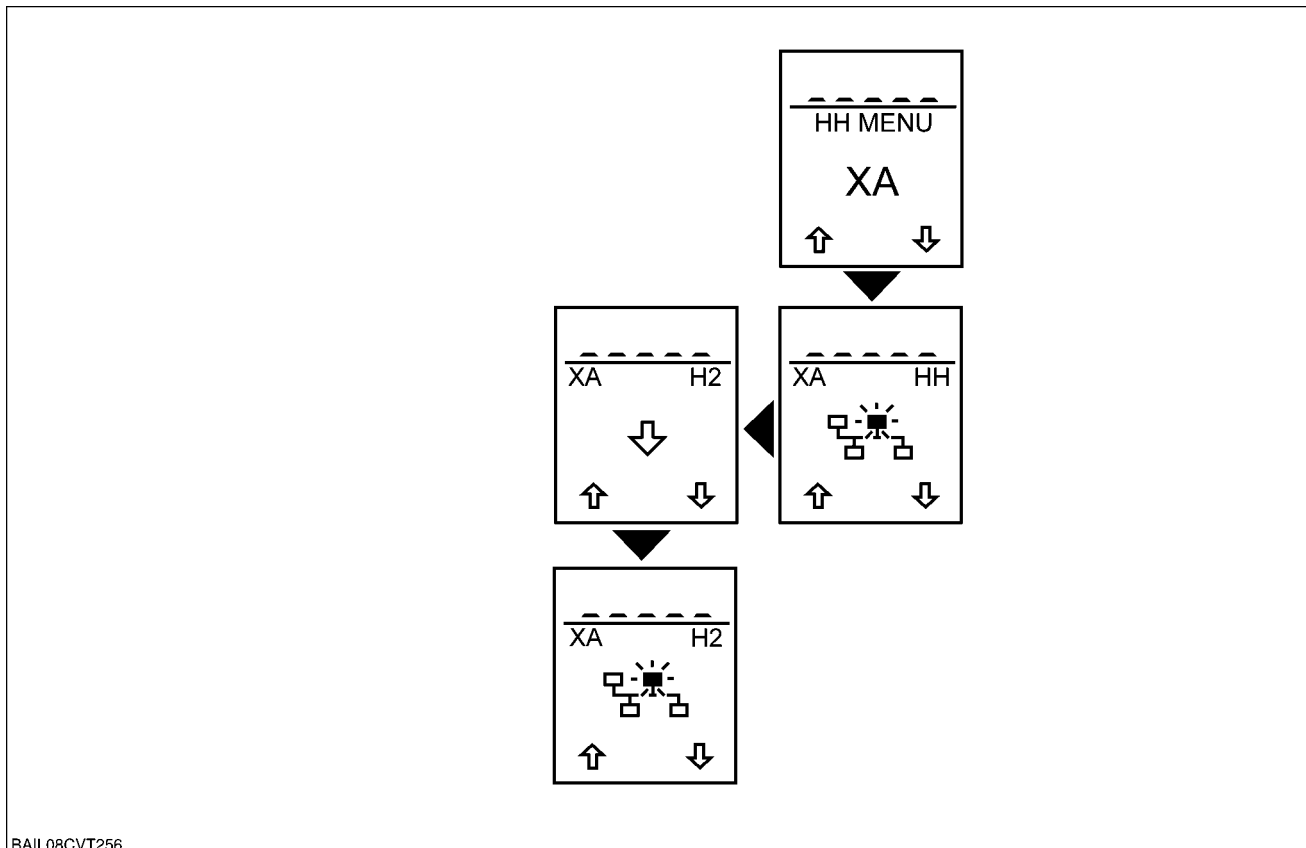

BAIL08CVT256

BAIL08CVT256 1

ELECTRONIC PARK LOCK VALUES

Select the electronic park lock sub-system by depressing the "menu" key.

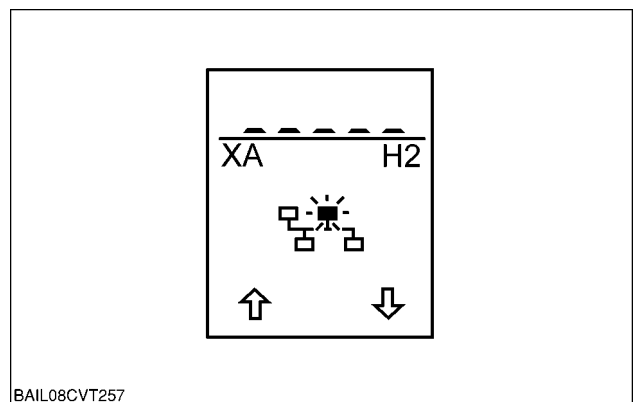

BAIL08CVT257

BAIL08CVT257 2

Control module Universal controller - H7 - Vehicle test modes

PUMA 130 Full powershift, PUMA 145 Full powershift, PUMA 160 Full powershift

NOTE: This menu is only for special vehicle tests to check clutch switch adjustment and hydraulic pressures.

H7 Menu Screen Select Diagram

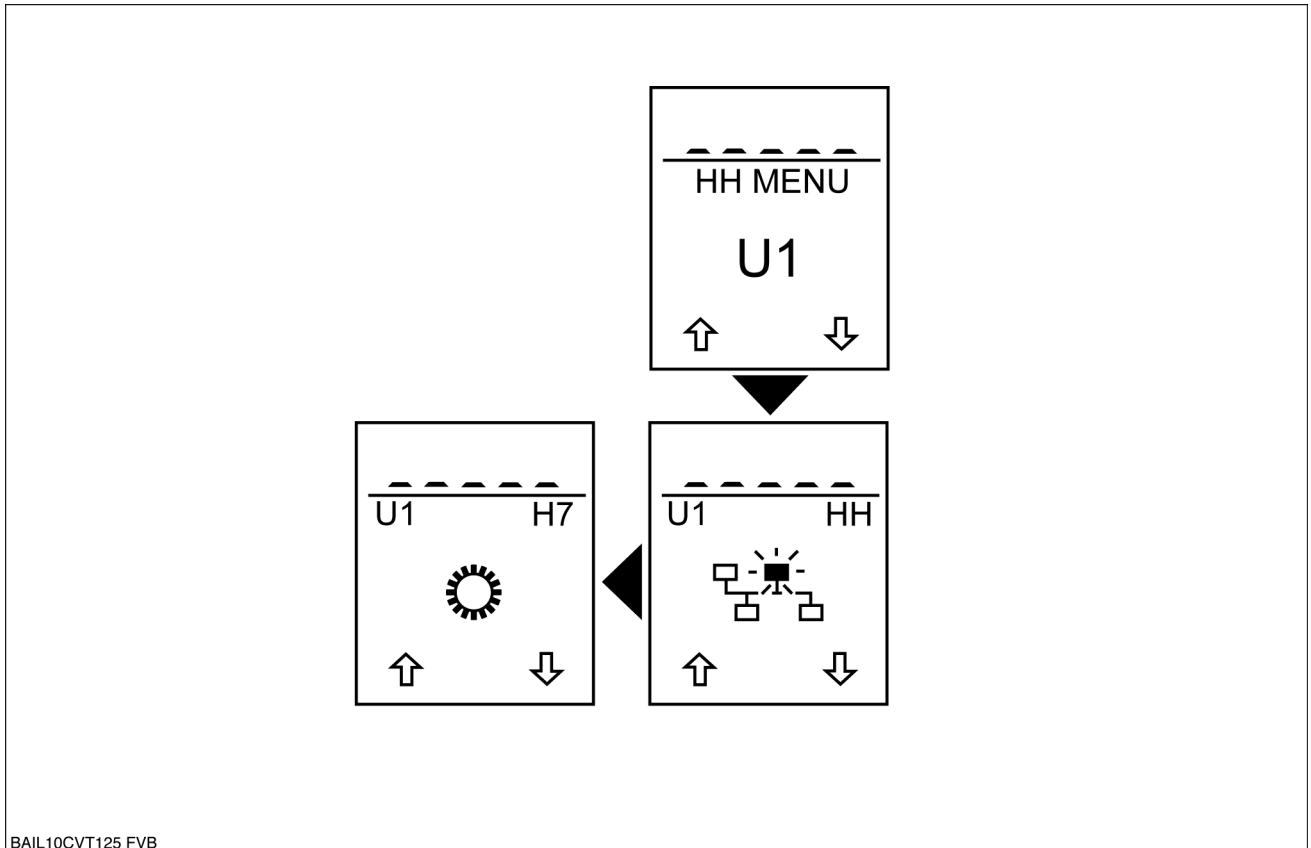

BAIL10CVT125AVB 1

Select the H7 menu by depressing the "Menu" key. The upper section of the display will show "Ch __"

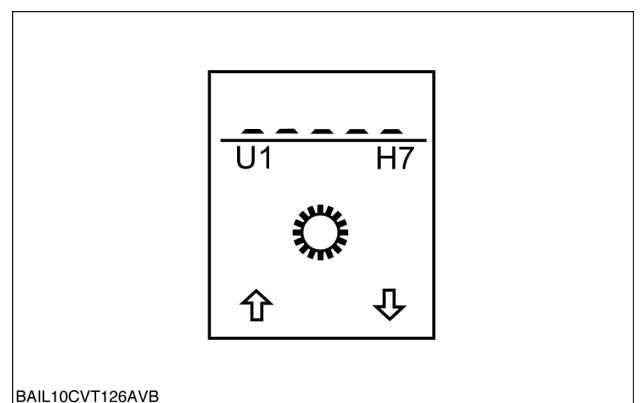

BAIL10CVT126AVB 2

The required channel can be selected by using the navigation "up" and "down" keys. After a delay the current option setting will be displayed, (refer to the table below for a description of each channel).

Channel Number	Description
Ch 1	Clutch switch test
Ch 2	Manual clutch adjustment
Ch 3	Manual quickfill adjustment

When the ratio has been calculated the optional speed value is displayed for five seconds followed by "End". The engine speed will return to idle, and the PTO will be stopped automatically.

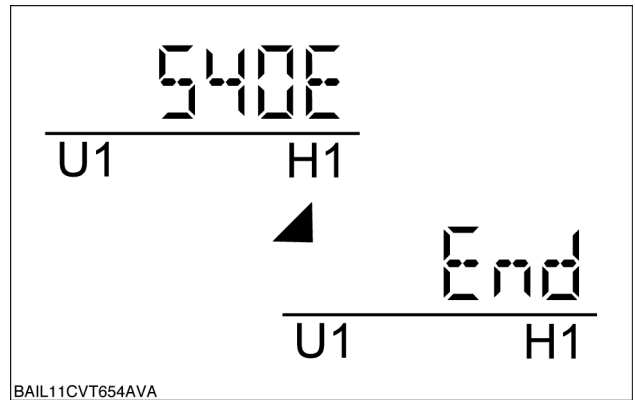

BAIL11CVT654AVA 32

Key OFF to store the calibration values.

NOTE: If an error occurs during calibration a "U" code will be displayed and the procedure will need to be repeated. Refer to the "U" code listing in **Control module - Fault code index (A.50.A)**.

Four Speed Electronic Shiftable Rear PTO (ESPTO)

Make sure that the correct option for the ESPTO is selected in channel four of the H3 for further information refer to **Control module Universal controller - H3 - Configurations and options (A.50.A)**.

ATTENTION: Disconnect any implements from the tractor as the PTO will operate during the calibration procedure.

Use the "up", "down" and "menu" keys on the ICU3 to navigate the HH menus to H1 and the PTO symbol on the U1 module.

The upper section of the display will show "CAL".

The upper section of the display will show "P11". While "P11" is being displayed the fully extended position of the ESPTO is being calibrated, when complete the calibration value will be displayed.

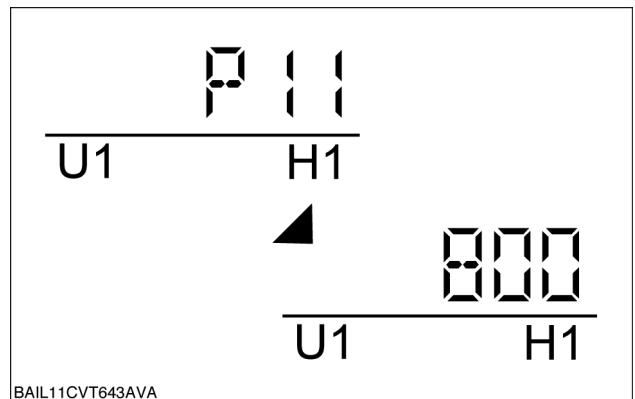

BAIL11CVT643AVA 33

The upper section of the display will then show "P12". While "P12" is being displayed the fully retracted position of the ESPTO is being calibrated, when complete the calibration value will be displayed.

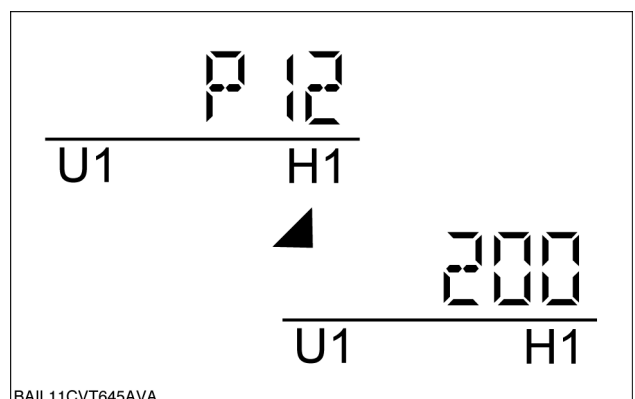

BAIL11CVT645AVA 34

The system being calibrated will be shown on the ICU3 and "CAL" will be shown on the upper section of the display.

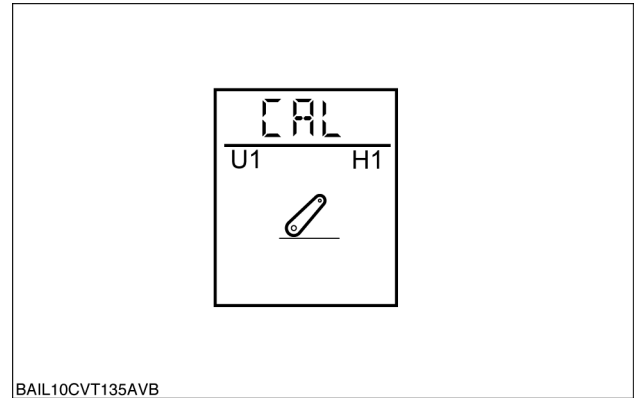

BAIL10CVT135AVB 22

Go to Calibration Method.

HH Menu Entry

Install the diagnostic connector **380000843** into the diagnostic socket (1).

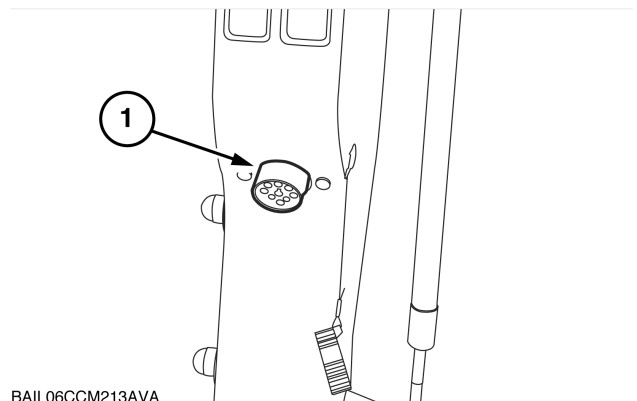

BAIL06CCM213AVA 23

Use the "up", "down" and "menu" keys on the ICU3 to navigate the HH menus to H1 and the EDC symbol, the upper section of the display will show "CAL".

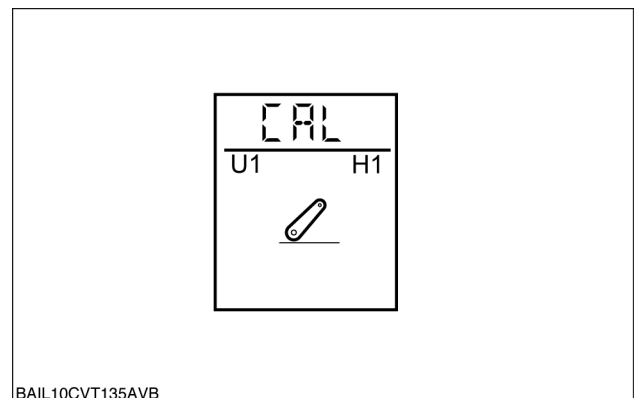

BAIL10CVT135AVB 24

Go to Calibration Method.

Calibration Method

Set the engine speed to **1100 - 1300 RPM**, with no noticeable hunting or surging.

Front Hitch Calibration Values

Use the "up", "down", and the "menu" keys to navigate the HH menus to H2 and the rear front hitch symbol on the U1 controller.

The upper section of the display will show "ch__"

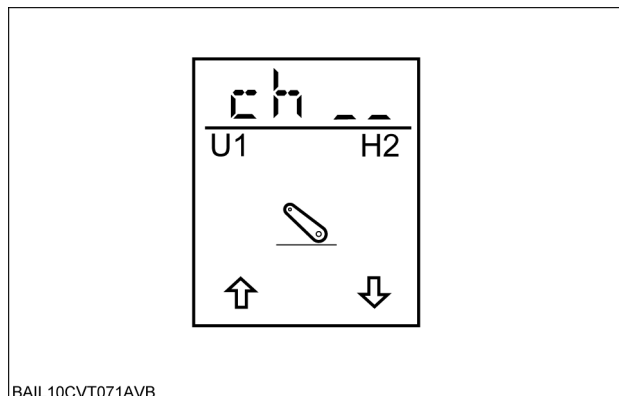

BAIL10CVT071AVB

BAIL10CVT071AVB 10

The required channel can be selected by using the navigation "up" and "down" keys.

After displaying the channel number, the stored calibration value for that channel is displayed, (refer to the table below for a description of each channel).

Channel number	Item	Value Range
Ch 1	Front hitch upper limit	3421 to 4700
Ch 2	Front hitch lower limit	200 to 1955

Depress the "menu" key" to continue navigating the "HH" menus.

Rear PTO Options

Use the "up", "down", and the "menu" keys to navigate the HH menus to H3 and the rear PTO symbol on the U1 controller.

The upper section of the display will show "ch__"

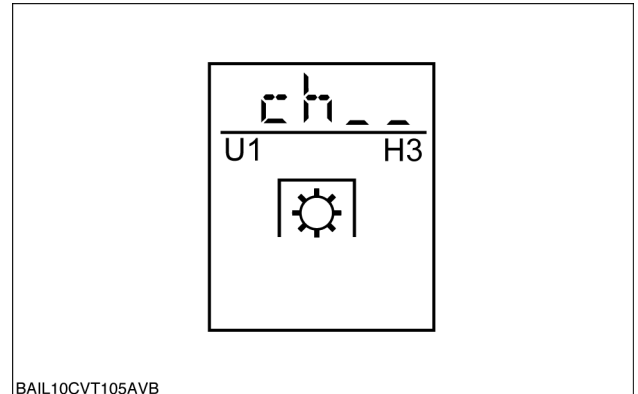

BAIL10CVT105AVB

BAIL10CVT105AVB 20

The required channel can be selected by using the navigation "up" and "down" keys.

After a delay the current option setting will be displayed, (refer to the table below for a description of each channel).

Channel Number	Description
Ch 1	Not used
Ch 2	Rear PTO fender switches selection
Ch 3	Rear PTO drop out speed selection
Ch 4	Not used

Channel 1 - Not Used

This channel is not used and "___" will be displayed.

Channel 2 - Rear PTO Fender Switches Selection

After a delay the current stored option will be displayed.

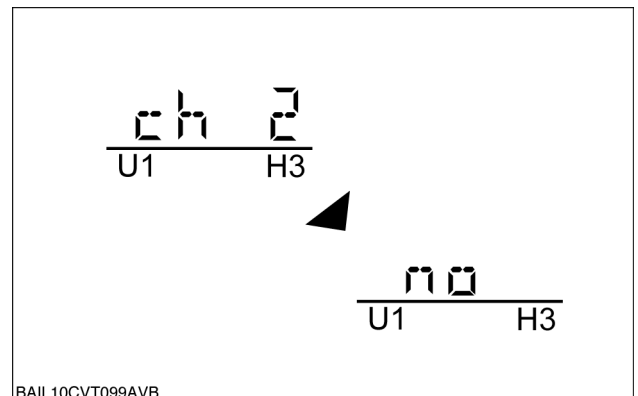

BAIL10CVT099AVB

BAIL10CVT099AVB 21

Use the "up" and "down" keys to toggle between the available options

"YES" - fender switches fitted

"no" - fender switches not fitted

NOTE: The default setting for this option is "no".

Depress and hold the "up" or "down" key until the instrument cluster bleeps, indicating the selection has been stored.

Depress the "menu" key to continue navigating the "HH" menus.

Channel 3 - Grid Heater Selection

After a delay the current stored option will be displayed.

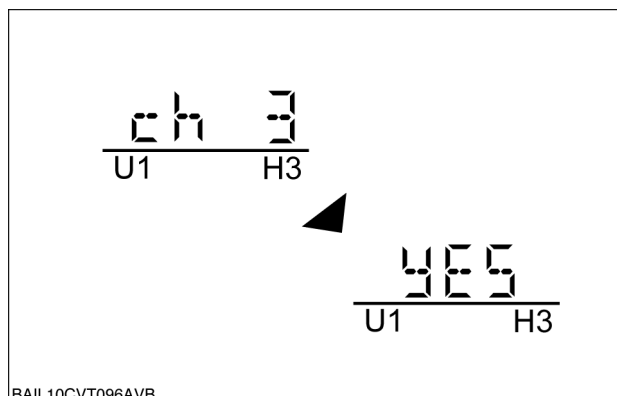

BAIL10CVT096AVB 14

Use the "up" and "down" keys to toggle between the available options:

"YES" - grid heater enabled

"no" - grid heater disabled

NOTE: The default setting for this option is "YES".

Depress and hold the "up" or "down" key until the instrument cluster bleeps, indicating the selection has been stored.

Depress the "menu" key to continue navigating the "HH" menus.

Channel 4 - Fuel Filter Heater Selection

After a delay the current stored option will be displayed.

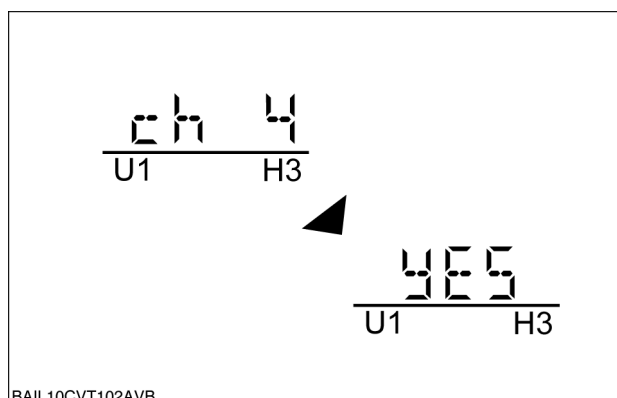

BAIL10CVT102AVB 15

Use the "up" and "down" keys to toggle between the available options:

"YES" - fuel filter heater enabled

"no" - fuel filter disabled

NOTE: The default setting for this option is "no".

Depress and hold the "up" or "down" key until the instrument cluster bleeps, indicating the selection has been stored.

Depress the "menu" key to continue navigating the "HH" menus.

HYDRAULIC, PNEUMATIC, ELECTRICAL, ELECTRONIC SYSTEMS - ELECTRONIC SYSTEM

Channel Number	Connector	Pin Number	Description	Typical Reading
Ch 58	X955 (CN3B)	11	High low pump not present input	0 - high flow pump present 12000 high flow pump not present
Ch 63	X955 (CN3B)	16	Left brake switch	0 - pedal depressed 12000 - pedal released
Ch 64	X955 (CN3B)	19	EDC external lower switch	0 - switch not pressed 12000 - switch pressed
Ch 66	X955 (CN3B)	21	12V PTO sense input	12000
Ch 72	X955 (CN3B)	29	Front hitch external raise switch	0 - switch not pressed 12000 - switch pressed
Ch 73	X955 (CN3B)	30	Front hitch external lower switch	0 - switch not pressed 12000 - switch pressed
Ch 75	X956 (CN4A)	22	Exhaust brake switch	0 - exhaust brake not pressed 12000 - exhaust brake pressed
Ch 81	X957 (CN4B)	13	Front hitch fender switch present input	0 - fender switch not fitted 12000 - fender switch fitted
Ch 82	X957 (CN4B)	14	Air conditioning pressure switch	0 - ?????? 12000 - ??????
Ch 83	X957 (CN4B)	15	Front PTO N/O switch	0 - switch in off position 12000 - switch in on position
Ch 84	X955 (CN4B)	16	Front PTO N/C switch	0 - switch in on position 12000 - switch in off position
Ch 86	X957 (CN4B)	21	Shuttle lever reverse switch	0 - lever in rest position 4200 - lever in reverse position
Ch 87	X957 (CN4B)	22	Shuttle lever forward switch	0 - lever in rest position 4200 - lever in forward position
Ch 91	X957 (CN4B)	30	EDC rockshaft position sensor	550 - rear hitch fully lowered 4200 - rear hitch fully raised
Ch 92	X957 (CN4B)	31	Front hitch position sensor	??? - rear hitch fully lowered ???? - rear hitch fully raised
Ch 100	X956 (CN4A)	07	A solenoid current	??? - when solenoid is off ???? - when solenoid is on

Contents

HYDRAULIC, PNEUMATIC, ELECTRICAL, ELECTRONIC SYSTEMS - A

FAULT CODES - 50.A

FUNCTIONAL DATA

ELECTRONIC SYSTEM

Fault code index	3
------------------------	---

HYDRAULIC, PNEUMATIC, ELECTRICAL, ELECTRONIC SYSTEMS - FAULT CODES

Reference	Description	Controller
4120	Rear Remote No.2 Spool Movement Too Low	
4121	Rear Remote No.2 Spool Movement Too High	
4122	Rear Remote No.2 Float Position Not Reached	
4123	Rear Remote No.2 Manually Operated	
4124	Rear Remote No.2 Driver Faulty	
4125	Rear Remote No.2 Potentiometer Faulty	
4126	Rear Remote No.2 Unable To Reach Neutral	
4127	Rear Remote No.2 Spool Not In Neutral At Key On.	
4128	Rear Remote No.3 No Control Message Received	
4129	Rear Remote No.3 Control Message Not Plausible	
4130	Rear Remote No.3 EEPROM Error	
4131	Rear Remote No.3 Switched To Failsafe	
4132	Rear Remote No.3 Under Voltage	
4133	Rear Remote No.3 Over Voltage	
4134	Rear Remote No.3 Spool Movement Too Low	
4135	Rear Remote No.3 Spool Movement Too High	
4136	Rear Remote No.3 Float Position Not Reached	
4137	Rear Remote No.3 Manually Operated	
4138	Rear Remote No.3 Driver Faulty	
4139	Rear Remote No.3 Potentiometer Faulty	
4140	Rear Remote No.3 Unable To Reach Neutral	
4141	Rear Remote No.3 Spool Not In Neutral At Key On	
4142	Rear Remote No.4 No Control Message Received	
4143	Rear Remote No.4 Control Message Not Plausible	
4144	Rear Remote No.4 EEPROM Error	
4145	Rear Remote No.4 Switched To Failsafe	
4146	Rear Remote No.4 Under Voltage	
4147	Rear Remote No.4 Over Voltage	
4148	Rear Remote No.4 Spool Movement Too Low	
4149	Rear Remote No.4 Spool Movement Too High	
4150	Rear Remote No.4 Float Position Not Reached	
4151	Rear Remote No.4 Manually Operated	
4152	Rear Remote No.4 Driver Faulty	

Contents

ENGINE AND PTO IN - B

FUEL AND INJECTION SYSTEM - 20.A

SERVICE

Fuel tank	
Remove	3
Install	10
Fuel injector	
Electrical test	17
Fuel line	
Low pressure - Connect	25

Fuel line Low pressure - Connect

1. Connect the pipe (1) to the fuel return pressure limiter.

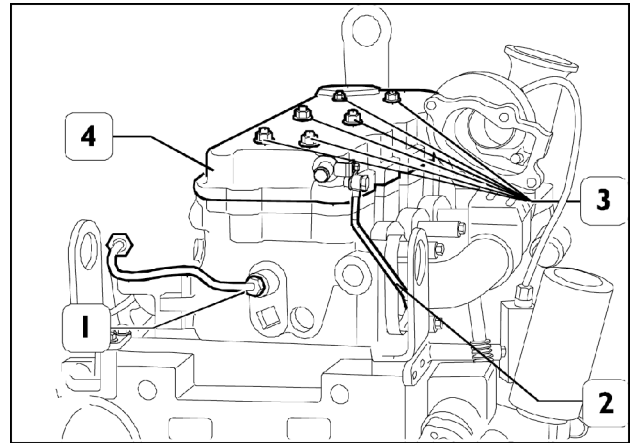

BAIL07APH408AMA 1

Index

ENGINE AND PTO IN - B

EXHAUST SYSTEM - 40.A

Engine brake - Install	6
Engine brake - Remove	5
Engine brake - Static description	3
Engine brake Control valve - Install	8
Engine brake Control valve - Remove	7
Exhaust line - Install	11
Exhaust line - Remove	9
Exhaust manifold - Install	13

Selective Catalytic Reduction (SCR) SCR muffler - Install

⚠ WARNING

Personal Protective Equipment (PPE) required. When assembling, operating, or servicing the machine, wear protective clothing and PPE necessary for the particular procedure. Some PPE that may be necessary includes protective shoes, eye and/or face protection, hard hat, heavy gloves, filter mask, and hearing protection.

Failure to comply could result in death or serious injury.

W0353A

NOTE: Make sure that all openings are sealed. Use new blanking caps.

1. ⚠ WARNING

Heavy object!
ALWAYS use a hoist or get assistance to lift the component.
Failure to comply could result in death or serious injury.

W0086A

Using a hoist or with the aid of another technician, install the SCR muffler onto the mounting bracket.

2. Install the SCR muffler retaining nuts below the mounting bracket.

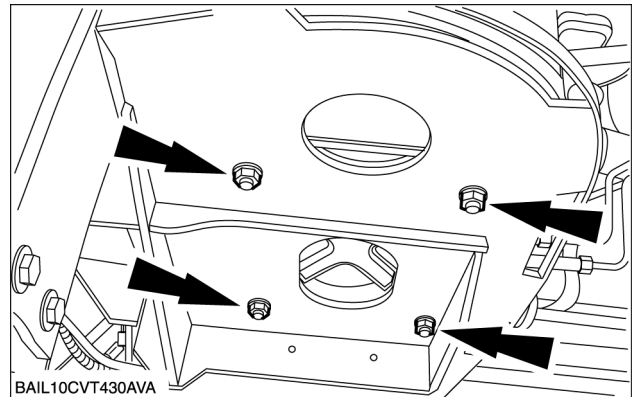

BAIL10CVT430AVA 1

3. Install SCR muffler clamp retaining bolt.

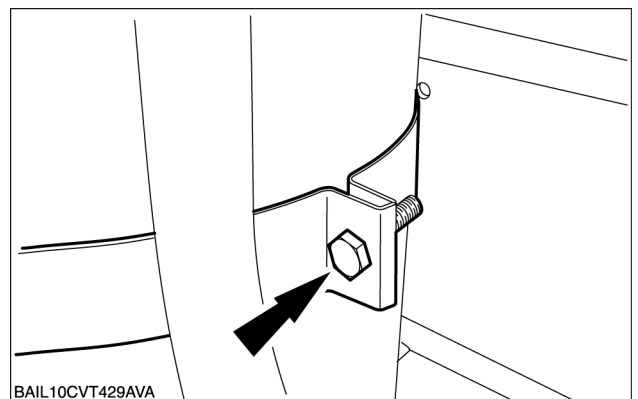

BAIL10CVT429AVA 2

8. Using a suitable wrench (1), remove the heated level sensor (2).

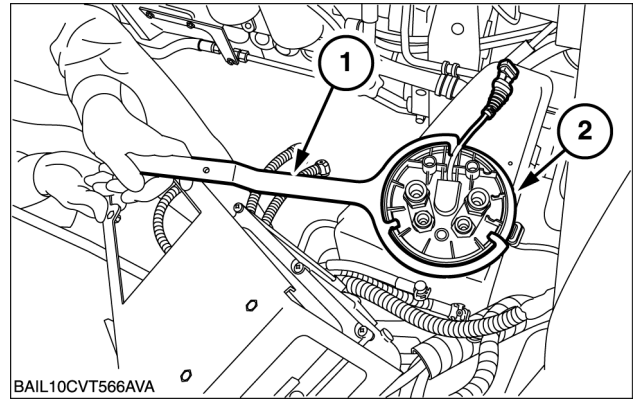

BAIL10CVT566AVA 7

CLICK HERE TO **DOWNLOAD** THE COMPLETE MANUAL

- Thank you very much for reading the preview of the manual.
- You can download the complete manual from: www.heydownloads.com by clicking the link below



- Please note: If there is no response to CLICKING the link, please download this PDF first and then click on it.

CLICK HERE TO **DOWNLOAD** THE COMPLETE MANUAL

23. Remove the oil cooler and the oil cooler supply and return pipes.

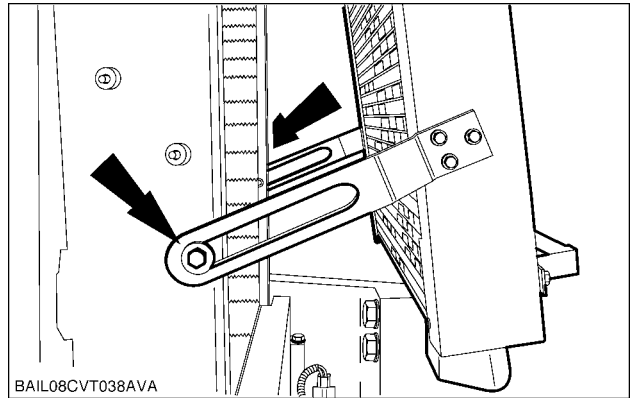

BAIL08CVT038AVA 23

24. Remove the radiator baffle plate.

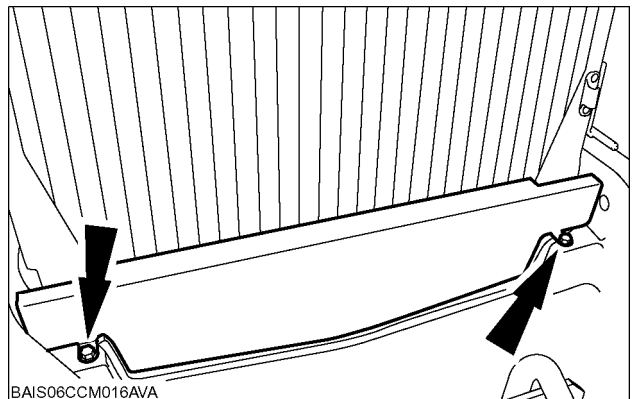

BAIS06CCM016AVA 24

25. Remove the radiator lower retaining bolts.

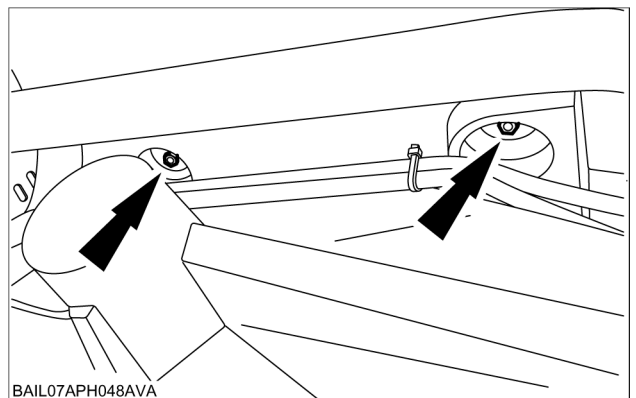

BAIL07APH048AVA 25

26. **⚠ WARNING**

Heavy object!
ALWAYS use a hoist or get assistance to lift the component.
Failure to comply could result in death or serious injury.

W0086A

Remove the radiator assembly.

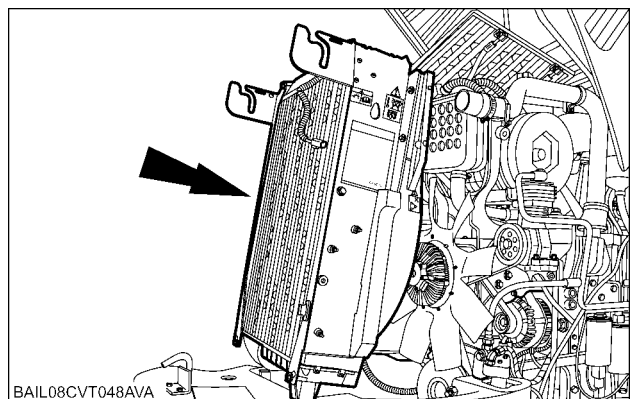

BAIL08CVT048AVA 26

Fan reversing system Valve - Install

1. Install the control valve.

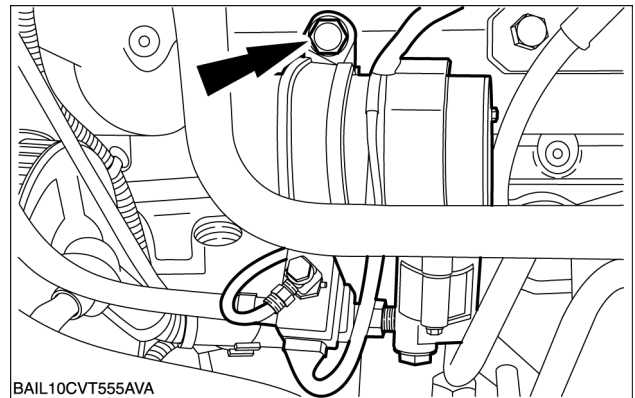

BAIL10CVT555AVA 1

2. Connect the electrical connector.

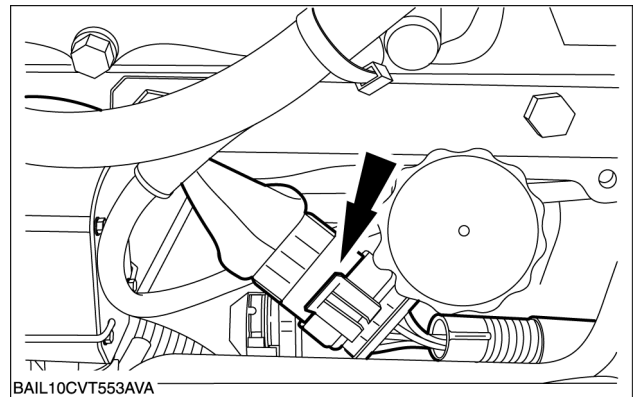

BAIL10CVT553AVA 2

3. Connect the vacuum line to the control valve.

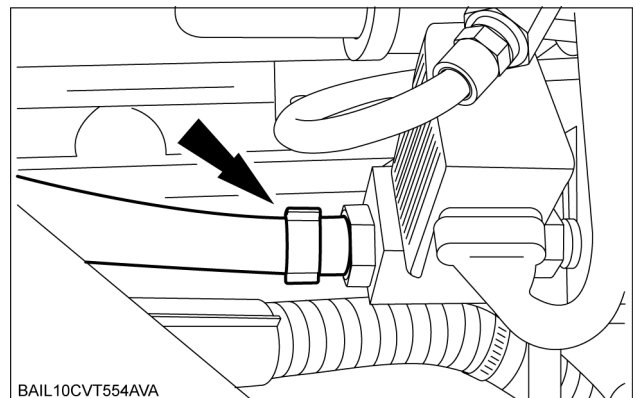

BAIL10CVT554AVA 3

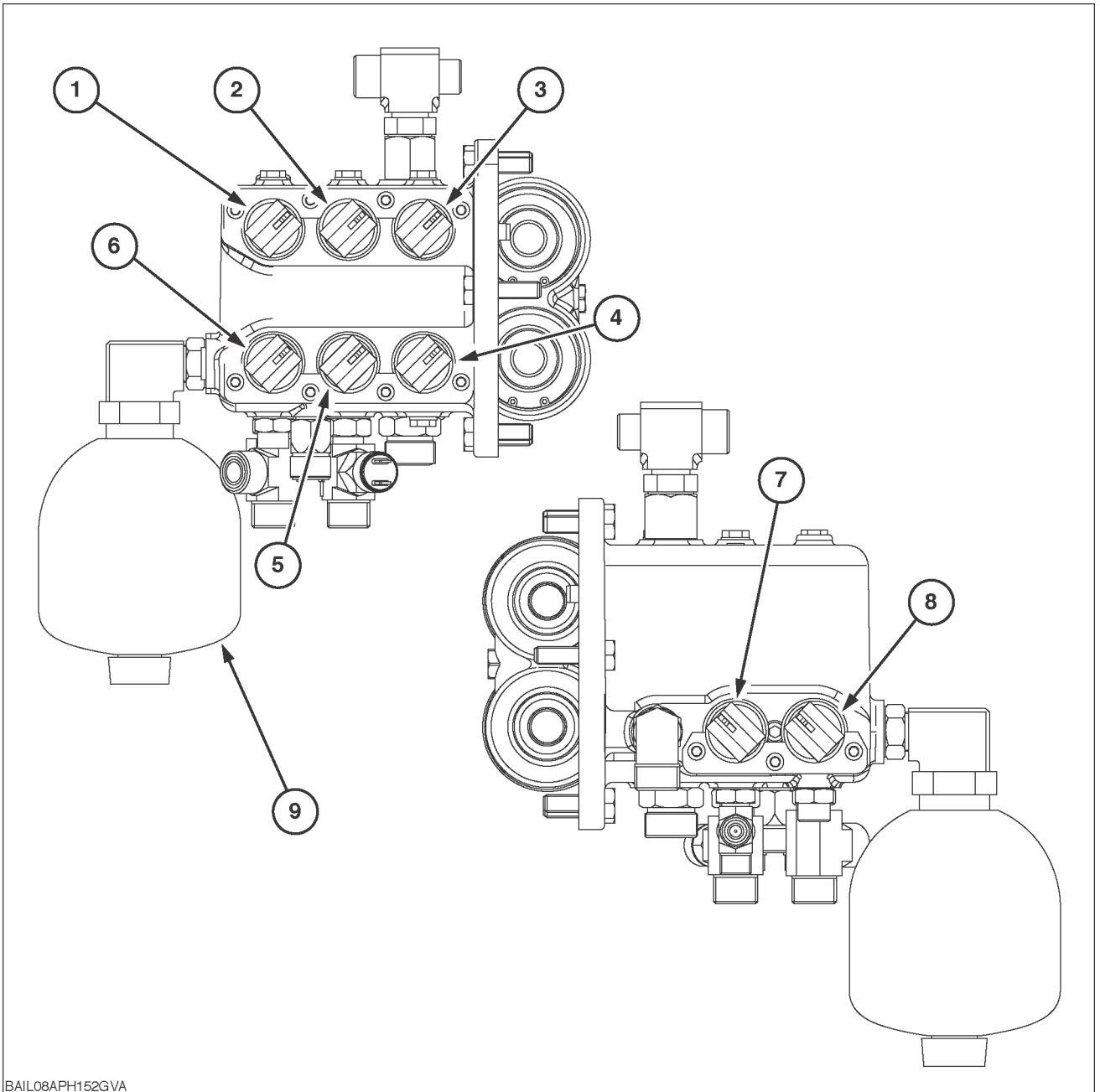

BAIL08APH152GVA

BAIL08APH152GVB 9

Control Valve Components

(1) Low range solenoid	(2) Reverse range solenoid
(3) Medium range solenoid	(4) High range solenoid
(5) 4WD solenoid	(6) PTO brake solenoid
(7) PTO solenoid	(8) Differential lock solenoid
(9) Accumulator	

13. Install cover (1) with a test shim (Sp). Screw (3) special tool 380000458 (3) onto special tool 50013 (4).

Place a dial test indicator (2) with the stylus touching the bearing inner race. Turn the shafts to settle the bearing rollers, reset the dial test indicator (2) to zero, making sure that the assembly is bottoming.

Through the lever of special tool 380000458 (3) bring the assembly to touch the cover (1) and read the travel (H) on the dial test indicator (2).

Adjust shim to be added is given by:

$$(S1) = (H) + (Sp) - (0 - 0.06 \text{ mm})$$

where:

(S1) = Adjust shim.

(Sp) = Test shim.

(H) = Travel reading.

0 - 0.06 mm = Output shaft bearing end play.

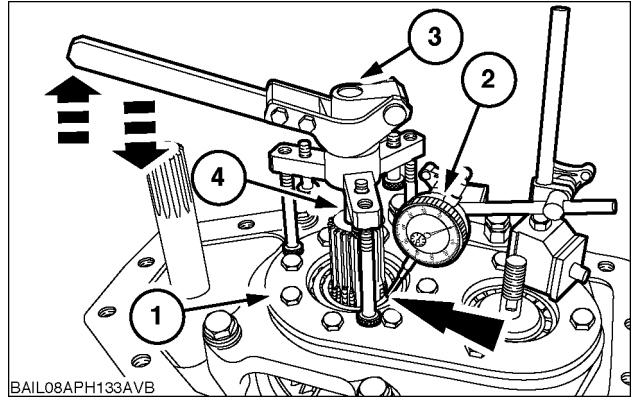

BAIL08APH133AVB 9

14. Dismantle special tools (3) and (4) as shown in figure 9. Remove the cover (1) as shown in figure 9, change the test shim (Sp) with the adjust shim (S1), reinstall the cover (1) as shown in figure 9 and special tools (3) and (4) as shown in figure 9. Repeat step 13 to check that the end play is to specification, 0 - 0.06 mm.

NOTE: Available adjust shims are detailed in the Specifications table, for additional information refer to **TRANSMISSION Semi-Powershift - General specification (C.20.D)**.

15. Remove special tools (2), (3) and (4) as shown in figure 9 and special tool 50013.
16. Install the output shaft lubrication plug.

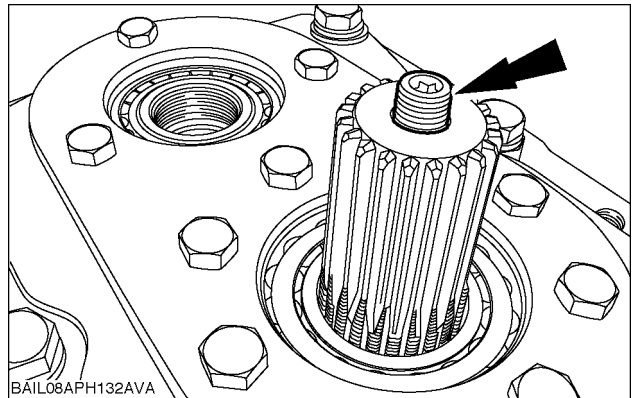

BAIL08APH132AVA 10

17. Remove the cover.

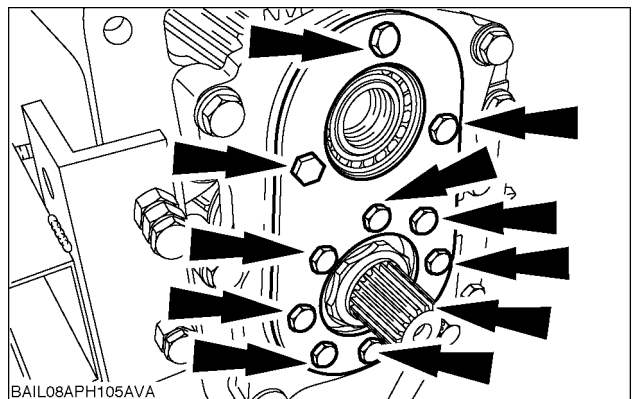

BAIL08APH105AVA 11

14. Remove the hydraulic oil pipe from between the hydraulic oil pump and the rear of the control valve.

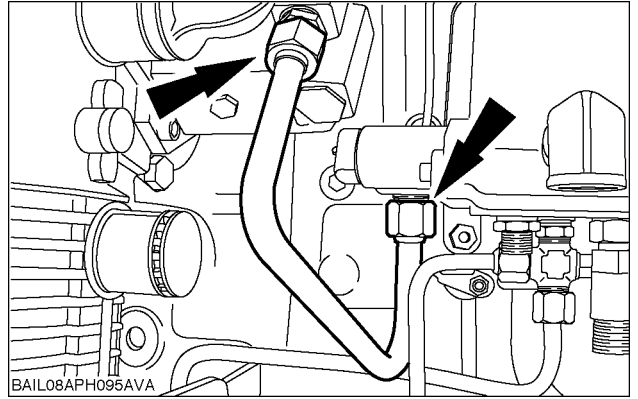

BAIL08APH095AVA 12

15. Disconnect the hydraulic oil pipes from the control valve.

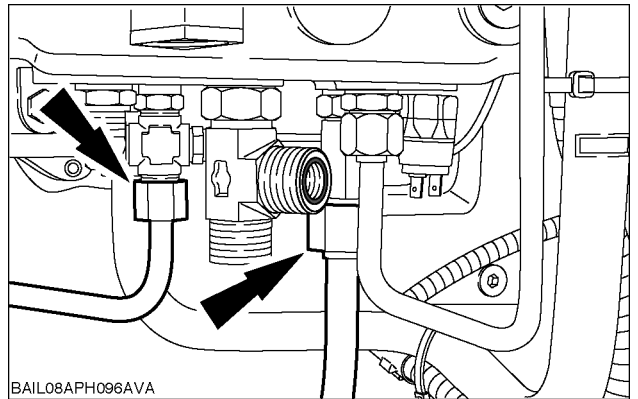

BAIL08APH096AVA 13

16. Disconnect the hydraulic oil pipes from the control valve.

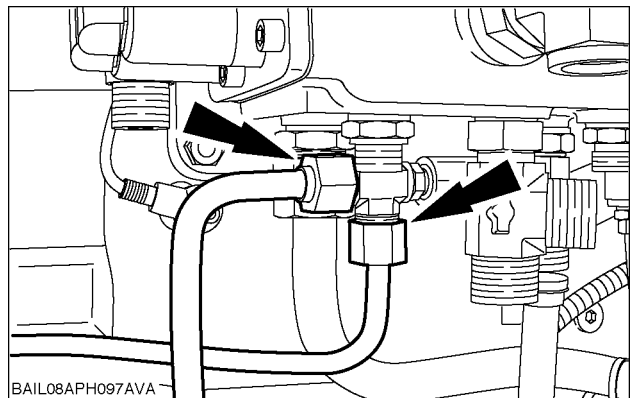

BAIL08APH097AVA 14

17. Disconnect the hydraulic oil pipe.

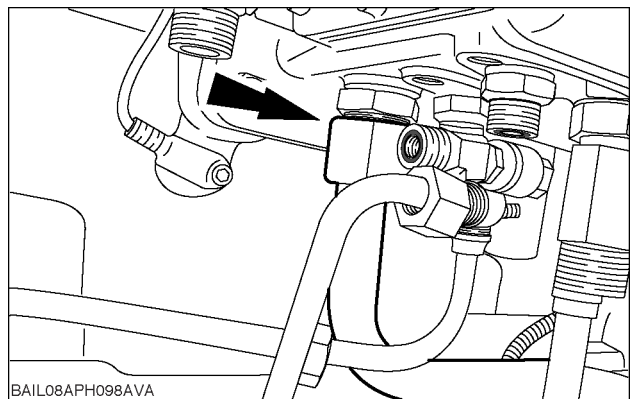

BAIL08APH098AVA 15

Control valve Master clutch valve - Assemble

PUMA 130 Semi powershift, PUMA 145 Semi powershift, PUMA 160 Semi powershift

Prior operation:

Disassemble the master clutch valve, for further information refer to **Control valve Master clutch valve - Disassemble (C.20.D)**

1. Thoroughly clean the mating surfaces and install a new gasket.

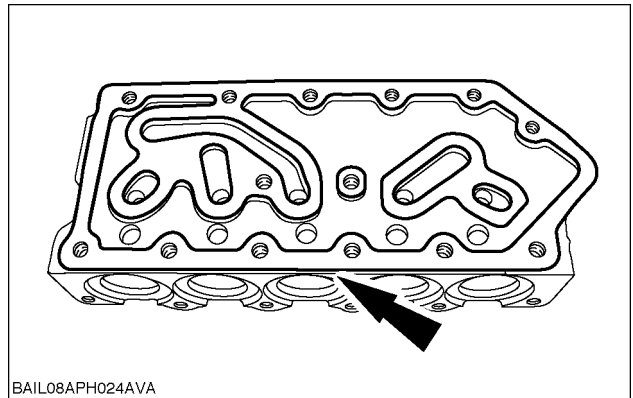

BAIL08APH024AVA 1

2. Install new O-ring seals on the lower hydraulic line connector.

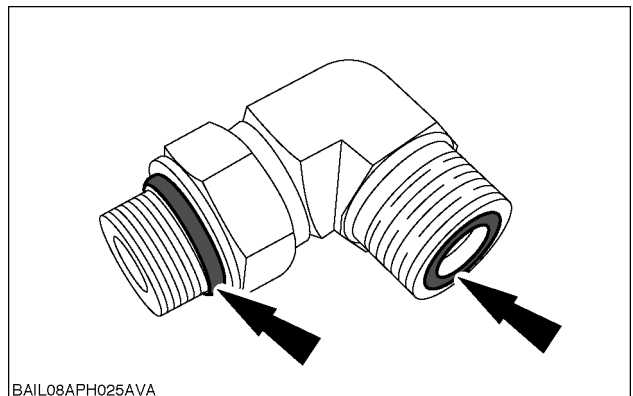

BAIL08APH025AVA 2

3. Install new O-ring seals on the upper hydraulic line connector.

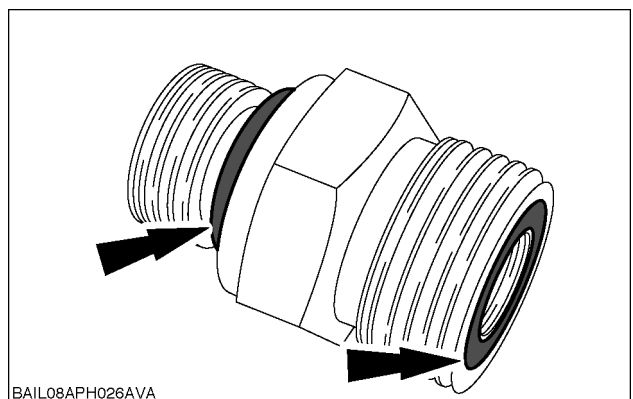

BAIL08APH026AVA 3

4. Remove the retaining ring. Slowly and carefully release the pressure on the special tool and remove the special tools from the speed clutch housing.

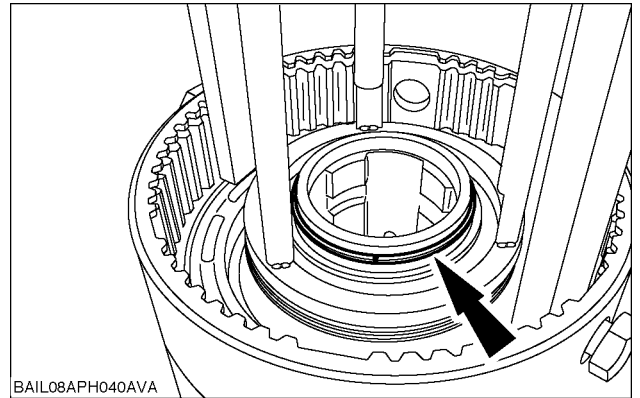

BAIL08APH040AVA 4

5. Remove the Belleville springs.

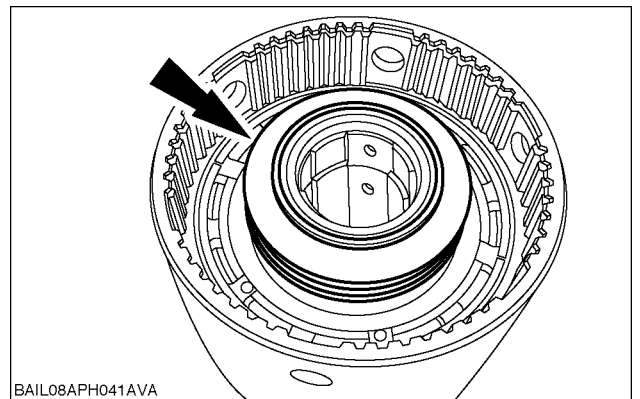

BAIL08APH041AVA 5

6. Using compressed air in the inlet port, remove the piston from the speed clutch housing.

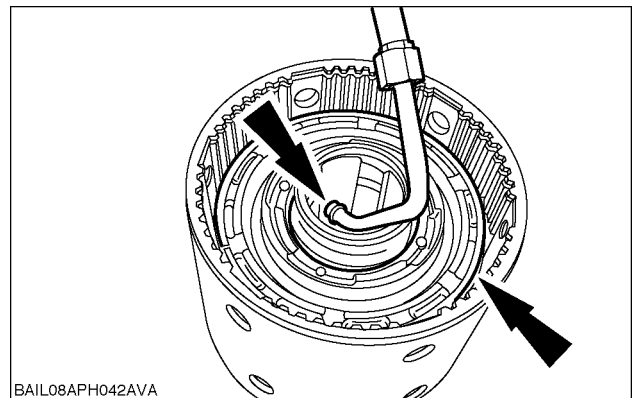

BAIL08APH042AVA 6

7. Remove and discard the piston seals.

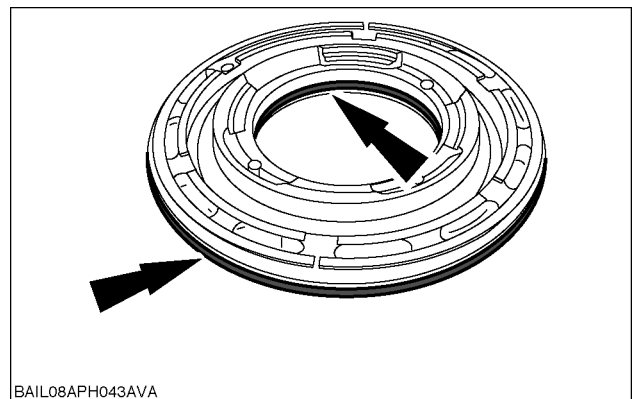

BAIL08APH043AVA 7

8. Repeat steps 1 to 7 to disassemble clutches D and E.

Next operation:

12. Withdraw the clutch piston assembly using two M5 screws placed in the piston.

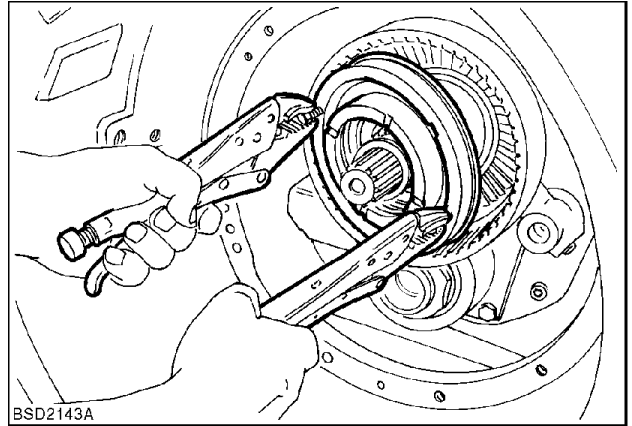

BSD2143A 11

13. Remove the retaining ring (1) and withdraw the clutch B housing.

NOTE: Before removing the 'B' clutch housing check for excessive movement and wear at the rear of the housing.

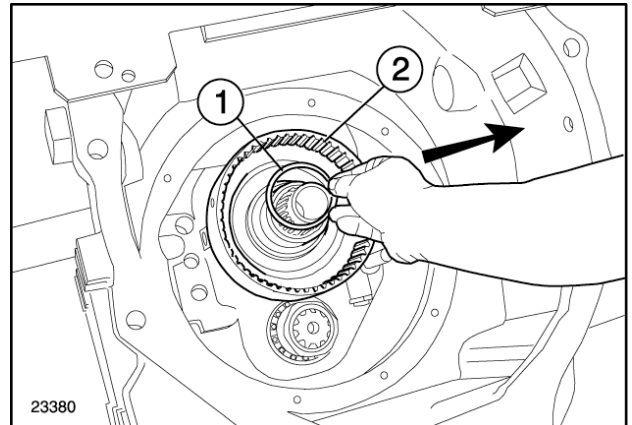

23380 12

14. Remove the oil manifold.

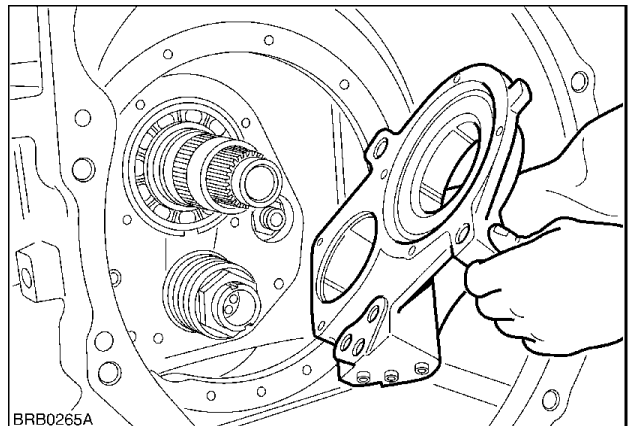

BRB0265A 13

15. Remove the 4 oil supply tubes and "O" rings from behind the manifold.

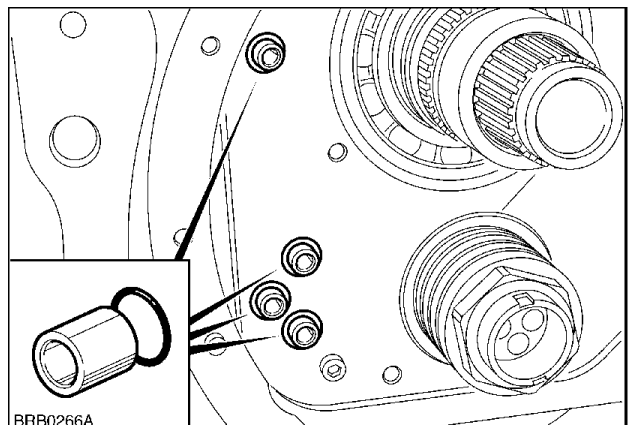

BRB0266A 14

4. Position tool no. **380000291 (2)** and puller tool no. **380000546 (1)** having a length of **300 mm** and complete with extraction brackets no. 292655 having a length of **300 mm** on clutch A (5), turn the tool bolt to compress the clutch release Belleville springs and remove the retaining ring. Disassemble tool no. **380000291 (2)** and puller (1) and retrieve Belleville springs.

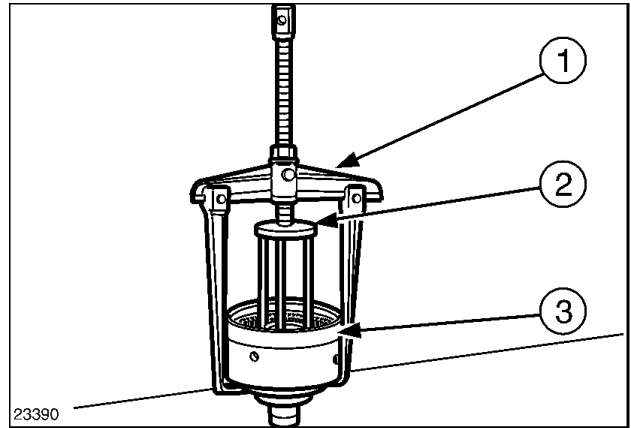

23390_795 4

5. Place the clutch A housing on the cover (2), blow compressed air into the control oil inlet hole and remove the piston (1). The piston seals should be carefully removed using a small screwdriver. Install new seals onto the piston, using fingers only. To install the piston, apply a generous coating of petroleum jelly to the piston seals and housing bore and using a suitable adaptor over the piston, press the piston into the housing. Ensure that the piston remains square to the housing bore during installation.

NOTE: It is recommended that the outer piston seals are compressed after installation onto the piston using suitable shim steel and a jubilee clip and then placed in a freezer overnight prior to installing into the clutch housing.

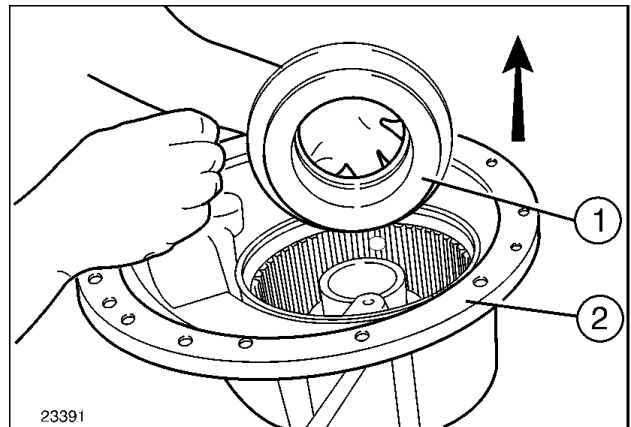

23391_101 5

Belleville spring installation

6. Stack the Belleville springs on a flat surface.
7. Slide over a suitable piston ring compression tool and tighten the tool to align the springs, (1).

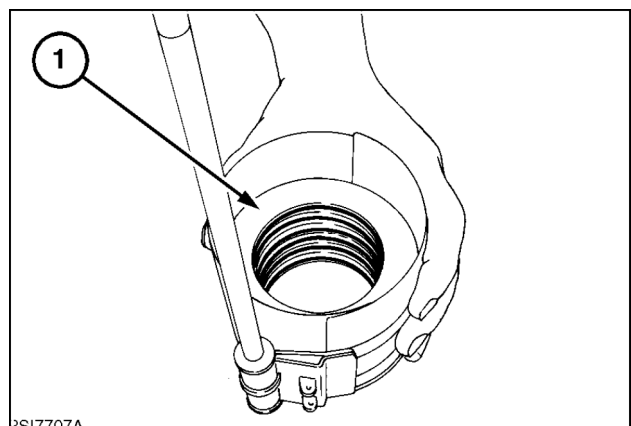

BSI7707A 6

Charge pressure sensor - Overview	49
PUMA 130 CVX, PUMA 145 CVX, PUMA 160 CVX	
Charge pressure sensor - Overview (Hydrostat)	50
PUMA 130 CVX, PUMA 145 CVX, PUMA 160 CVX	
Pressure sensor - Overview (Clutch A)	51
PUMA 130 CVX, PUMA 145 CVX, PUMA 160 CVX	
Pressure sensor - Overview (Clutch B)	52
PUMA 130 CVX, PUMA 145 CVX, PUMA 160 CVX	
Temperature sensor - Overview	53
PUMA 130 CVX, PUMA 145 CVX, PUMA 160 CVX	
Speed sensor - Overview (Ring gear)	54
PUMA 130 CVX, PUMA 145 CVX, PUMA 160 CVX	
Position sensor - Overview (F2/R1)	55
PUMA 130 CVX, PUMA 145 CVX, PUMA 160 CVX	
Overview (Fly wheel torque sensor)	56
PUMA 130 CVX, PUMA 145 CVX, PUMA 160 CVX	

SERVICE

Accumulator	
Replace	57
PUMA 130 CVX, PUMA 145 CVX, PUMA 160 CVX	
Control valve	
Replace (Safety valve, clutch "A", clutch "B")	59
PUMA 130 CVX, PUMA 145 CVX, PUMA 160 CVX	
Replace (Shift cylinder)	61
PUMA 130 CVX, PUMA 145 CVX, PUMA 160 CVX	
Valve block	
Remove	63
PUMA 130 CVX, PUMA 145 CVX, PUMA 160 CVX	
Disassemble	65
PUMA 130 CVX, PUMA 145 CVX, PUMA 160 CVX	
Assemble	67
PUMA 130 CVX, PUMA 145 CVX, PUMA 160 CVX	
Install	70
PUMA 130 CVX, PUMA 145 CVX, PUMA 160 CVX	
Hydrostat	
Remove	72
PUMA 130 CVX, PUMA 145 CVX, PUMA 160 CVX	
Install	74
PUMA 130 CVX, PUMA 145 CVX, PUMA 160 CVX	
Summing planetary gear	
Remove	77
PUMA 130 CVX, PUMA 145 CVX, PUMA 160 CVX	
Disassemble	79
PUMA 130 CVX, PUMA 145 CVX, PUMA 160 CVX	
Assemble	82
PUMA 130 CVX, PUMA 145 CVX, PUMA 160 CVX	
Install	86
PUMA 130 CVX, PUMA 145 CVX, PUMA 160 CVX	
Clutch	
Remove (A and B)	88
PUMA 130 CVX, PUMA 145 CVX, PUMA 160 CVX	

TRANSMISSION Continuously Variable Transmission (CVT) - Sectional view

PUMA 130 CVX, PUMA 145 CVX, PUMA 160 CVX

Parts

A	Clutch A	B	Clutch B
1	Hydrostat (fixed, driven by engine)	2	Hydrostat pump shaft (fixed, connected with sun gear (3))
3	Sun gear (input, summing planetary gear)	4	Planetary carrier
5	Spur gear driven by oil motor	6	Planetary gear (double wheel 3x)
7	Ring gear	8	Sun gear (output, summing planetary gear F2)
9	Hollow shaft (output, summing planetary gear F1/R1)	10	Gear wheel, F1
11	Synchroniser unit F2/R1	12	Gear wheel, R1
13	Gear wheel, F2	14	Output shaft (fixed, connected with pinion)
15	PTO shaft (drive for all hydraulic pumps)	16	All-wheel drive shaft

Accumulator - Replace

PUMA 130 CVX, PUMA 145 CVX, PUMA 160 CVX

⚠ WARNING

Pressurized system!

Before attempting any service procedure, it is your responsibility to know the number of accumulators on the machine, and the correct procedure for releasing the pressure of each accumulator.

Failure to comply could result in death or serious injury.

W0136A

TRANSMISSION Continuously Variable Transmission (CVT) - Exploded view (Solenoid valves, sensors, hydraulic lines) (C.20.G)

Prior operation:

Remove the rear right wheel - see **Rear wheel - Remove (D.50.C)**.

Removal

1. Loosen the screws and remove the cover.

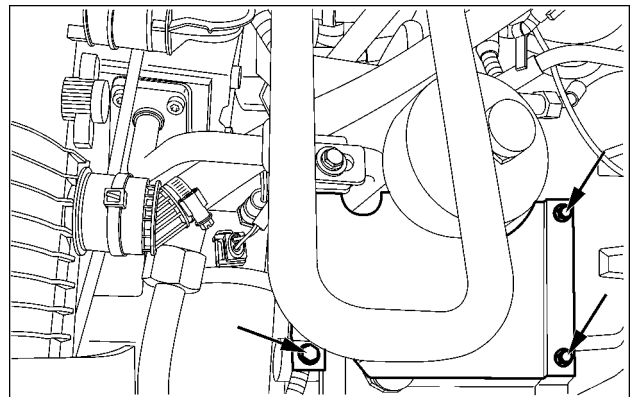

NOTE: Thoroughly clean the area around the accumulator.

2. **⚠ WARNING**

Pressurized system!

The accumulator contains highly pressurized nitrogen gas. If the accumulator system does not function correctly, replace the accumulator. DO NOT attempt to repair the accumulator.

Failure to comply could result in death or serious injury.

W0290A

Remove the accumulator (245).

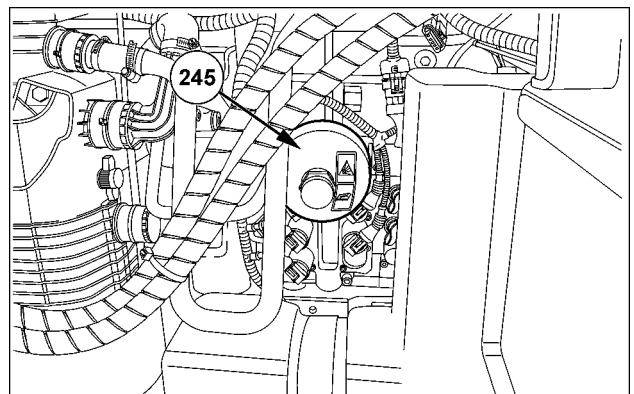

4. Release the circlips (45) and remove the bearings (43).

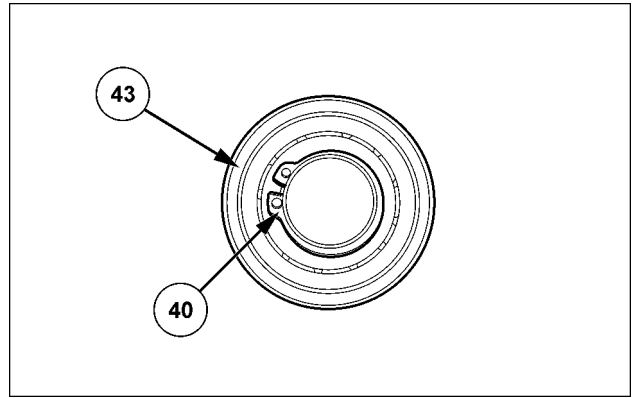

SS10F111 4

Cover, summing planetary gear

5. Release the circlip (29) and remove together with the cover plate (28). Remove the ring gear (27) and the ring gear carrier from the cover (22).

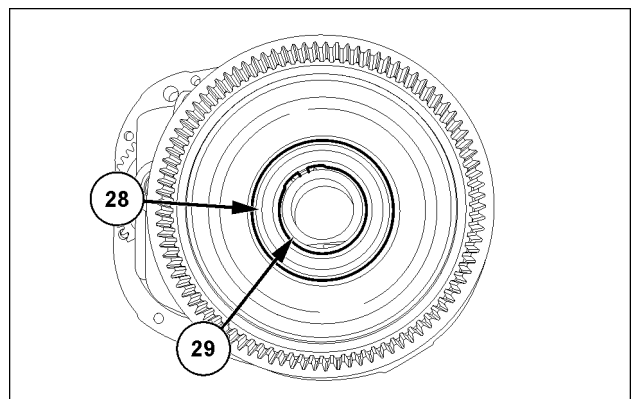

SS10F113 5

6. Remove the bearing (23) from the cover (22).

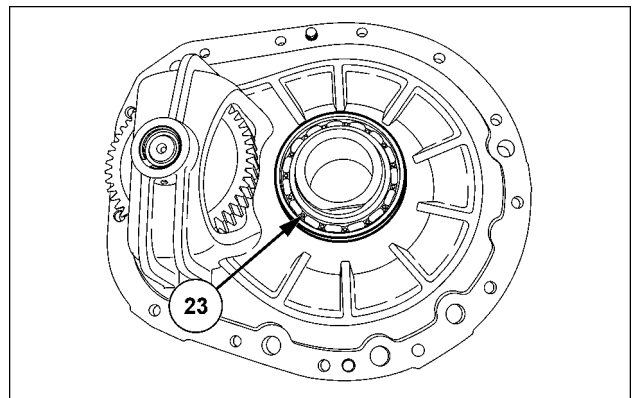

SS10F114 6

7. Remove the bearing (23) and the circlip (24) from the ring gear carrier (26).

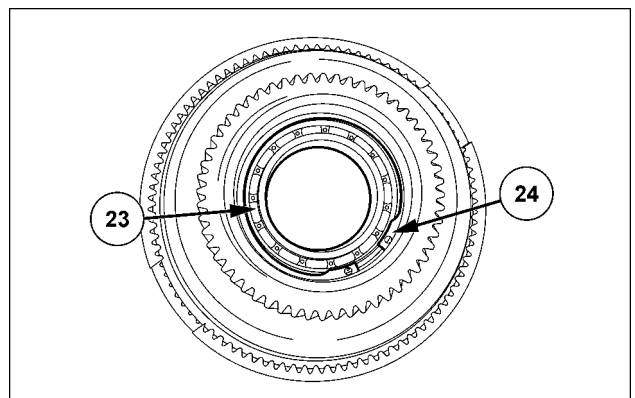

SS10F115 7

8. Unscrew the screws (180) and remove the magnet (177) with the bracket.

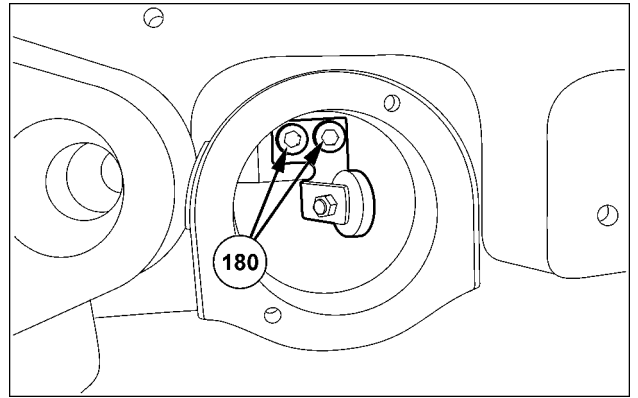

SS10F063 8

9. Remove the shift unit (shift rod, selector shaft, inner disc support) as one.

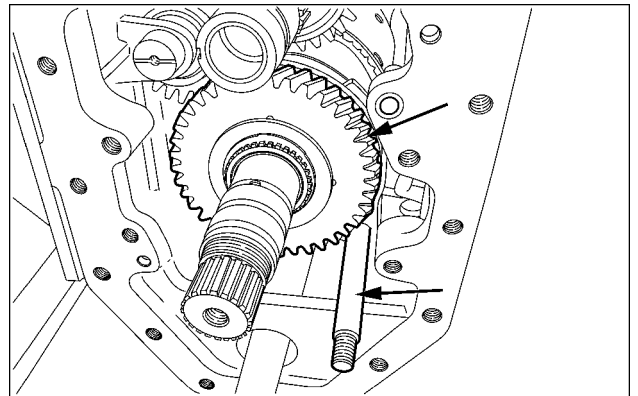

SS10F066 9

NOTE: Thoroughly clean and inspect all parts for wear or damage and replace if necessary.

Next operation:
Gear and synchroniser - Disassemble (F2/R1) (C.20.G)

Index

TRANSMISSION, DRIVE AND PTO OUT - C

TRANSMISSION Continuously Variable Transmission (CVT) - 20.G

TRANSMISSION Continuously Variable Transmission (CVT) - Exploded view (Transmission output)	38
PUMA 130 CVX, PUMA 145 CVX, PUMA 160 CVX	
TRANSMISSION Continuously Variable Transmission (CVT) - Exploded view (Solenoid valves, sensors, hydraulic lines)	40
PUMA 130 CVX, PUMA 145 CVX, PUMA 160 CVX	
Accumulator - Replace	57
PUMA 130 CVX, PUMA 145 CVX, PUMA 160 CVX	
Clutch - Assemble (A and B)	94
PUMA 130 CVX, PUMA 145 CVX, PUMA 160 CVX	
Clutch - Disassemble (A and B)	91
PUMA 130 CVX, PUMA 145 CVX, PUMA 160 CVX	
Clutch - Install (A and B)	99
PUMA 130 CVX, PUMA 145 CVX, PUMA 160 CVX	
Clutch - Remove (A and B)	88
PUMA 130 CVX, PUMA 145 CVX, PUMA 160 CVX	
Control valve - Overview (Safety valve)	43
PUMA 130 CVX, PUMA 145 CVX, PUMA 160 CVX	
Control valve - Overview (Solenoid valves)	44
PUMA 130 CVX, PUMA 145 CVX, PUMA 160 CVX	
Control valve - Replace (Safety valve, clutch "A", clutch "B")	59
PUMA 130 CVX, PUMA 145 CVX, PUMA 160 CVX	
Control valve - Replace (Shift cylinder)	61
PUMA 130 CVX, PUMA 145 CVX, PUMA 160 CVX	
Fork and shift rail - Adjust	116
PUMA 130 CVX, PUMA 145 CVX, PUMA 160 CVX	
Gear and synchroniser - Assemble (F2/R1)	106
PUMA 130 CVX, PUMA 145 CVX, PUMA 160 CVX	
Gear and synchroniser - Disassemble (F2/R1)	104
PUMA 130 CVX, PUMA 145 CVX, PUMA 160 CVX	
Gear and synchroniser - Install (F2/R1)	109
PUMA 130 CVX, PUMA 145 CVX, PUMA 160 CVX	
Gear and synchroniser - Install (Reverse)	115
PUMA 130 CVX, PUMA 145 CVX, PUMA 160 CVX	
Gear and synchroniser - Remove (F2/R1)	101
PUMA 130 CVX, PUMA 145 CVX, PUMA 160 CVX	
Gear and synchroniser - Remove (Reverse)	114
PUMA 130 CVX, PUMA 145 CVX, PUMA 160 CVX	
Hydrostat - General specification	9
PUMA 130 CVX, PUMA 145 CVX, PUMA 160 CVX	
Hydrostat - Hydraulic schema	47
PUMA 130 CVX, PUMA 145 CVX, PUMA 160 CVX	
Hydrostat - Install	74
PUMA 130 CVX, PUMA 145 CVX, PUMA 160 CVX	
Hydrostat - Remove	72
PUMA 130 CVX, PUMA 145 CVX, PUMA 160 CVX	
Hydrostat - Static description	45
PUMA 130 CVX, PUMA 145 CVX, PUMA 160 CVX	
Sensing system - Overview (Fly wheel torque sensor)	56
PUMA 130 CVX, PUMA 145 CVX, PUMA 160 CVX	
Sensing system - Replace (Fly wheel torque sensor)	125
PUMA 130 CVX, PUMA 145 CVX, PUMA 160 CVX	
Sensing system Charge pressure sensor - Overview	49
PUMA 130 CVX, PUMA 145 CVX, PUMA 160 CVX	
Sensing system Charge pressure sensor - Overview (Hydrostat)	50
PUMA 130 CVX, PUMA 145 CVX, PUMA 160 CVX	
Sensing system Charge pressure sensor - Replace	122
PUMA 130 CVX, PUMA 145 CVX, PUMA 160 CVX	
Sensing system Charge pressure sensor - Replace (Hydrostat)	123
PUMA 130 CVX, PUMA 145 CVX, PUMA 160 CVX	
Sensing system Position sensor - Overview (F2/R1)	55
PUMA 130 CVX, PUMA 145 CVX, PUMA 160 CVX	
Sensing system Position sensor - Replace (F2/R1)	124
PUMA 130 CVX, PUMA 145 CVX, PUMA 160 CVX	

19. Install the support plate (1) assembly. Make sure the selector fork shaft (2) is correctly located in the support plate.

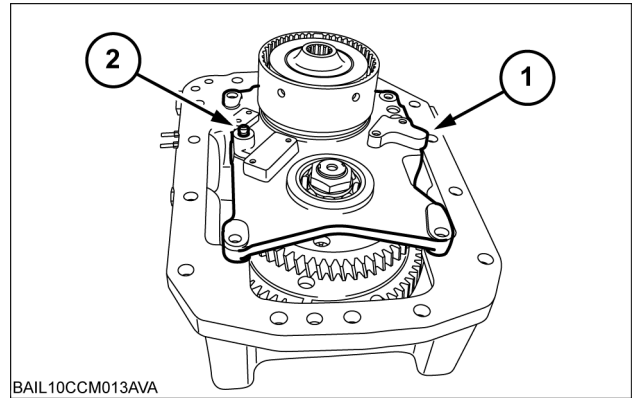

BAIL10CCM013AVA 20

20. Install the support plate retaining bolts. Tighten to **88 Nm (65 lb ft)**.

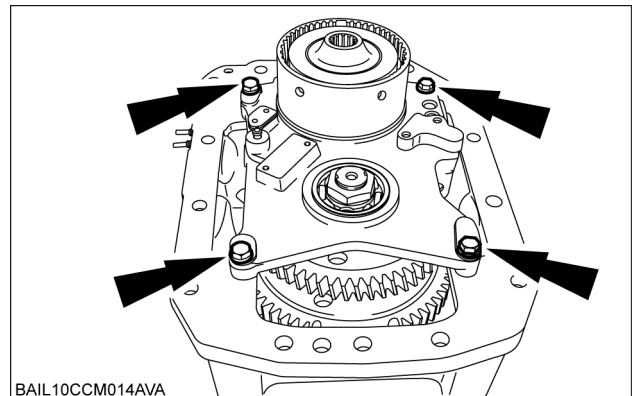

BAIL10CCM014AVA 21

21. Install the brake band (2) and brake piston housing (1).

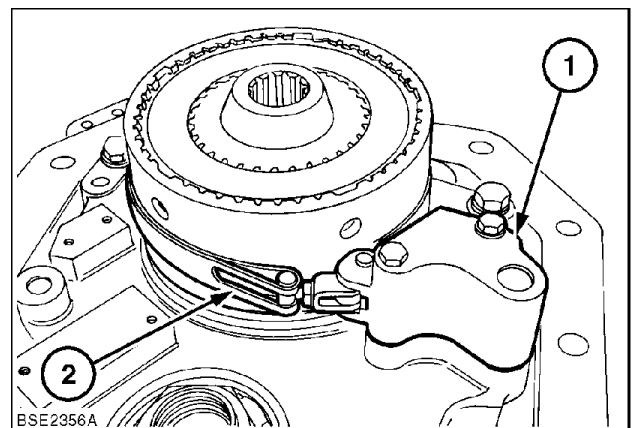

BSE2356A 22

22. Using a suitable dowell (1), lock the gear and tighten the shaft nut (2). Tighten to **294 Nm (217 lb ft)**. Stake the retaining nut.

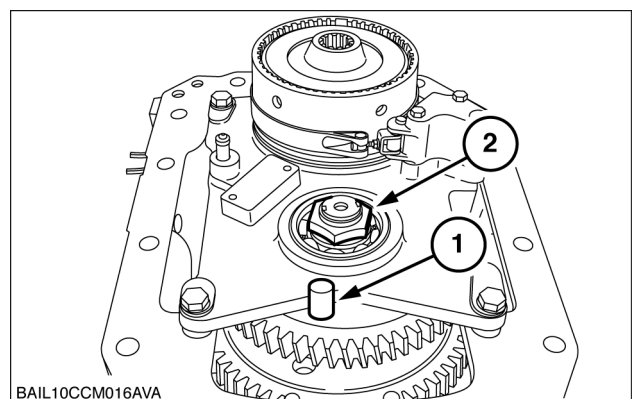

BAIL10CCM016AVA 23

PTO Anti Stall

PTO anti-stall feature. If when operating with high inertia equipment the PTO is engaged at too low an engine speed, an Anti Stall feature will automatically disable the PTO start up and a symbol will appear in the cluster. The system will be disabled until the PTO control is returned to the Off position at which time the Anti Stall symbol will be extinguished. Re-engage the PTO at a higher engine speed.

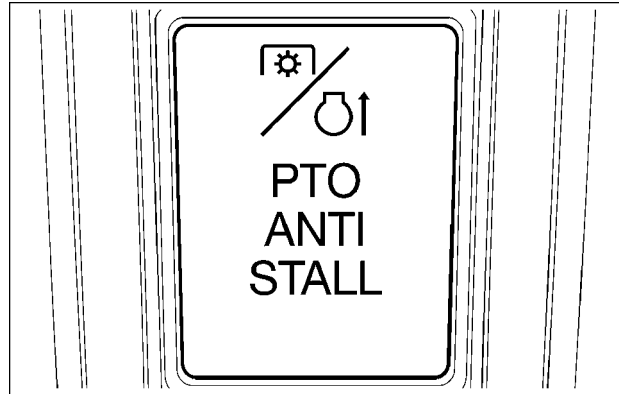

BRK5857C 3

The PTO brake is automatically engaged when the PTO is disengaged. This brake can be released by holding down a separate switch. The brake will re-engage when the switch is released.

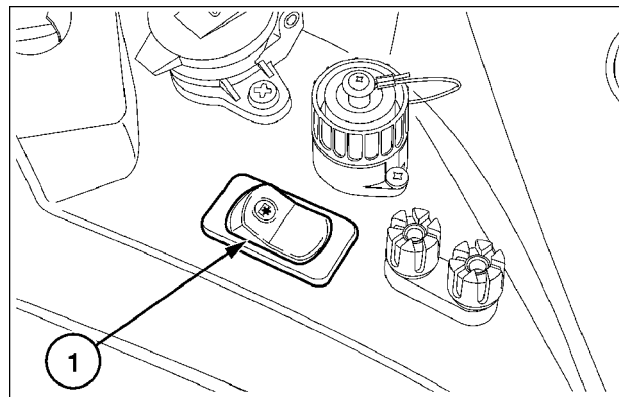

BRL6438B 4

NOTICE: An automatic PTO brake is installed to stop shaft rotation quickly when the PTO is disengaged. To avoid overstressing the PTO brake, slow down the implement by reducing engine speed before disengaging the PTO. This is particularly important with implements having a high inertia. Such implements should, ideally, be fitted with an overrun clutch. To avoid damage to the brake when operating high inertia implements, hold down the switch (1), to disengage the brake and allow the implement to come to rest naturally.

21. Remove the PTO output shaft.

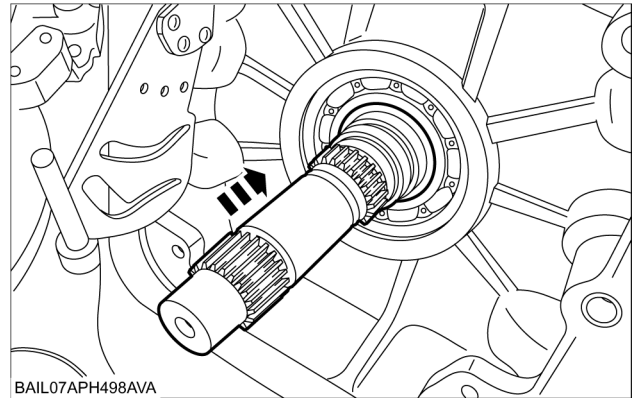

BAIL07APH498AVA

BAIL07APH498AVA 20

22. Remove the bearing (1) and the seal (2).

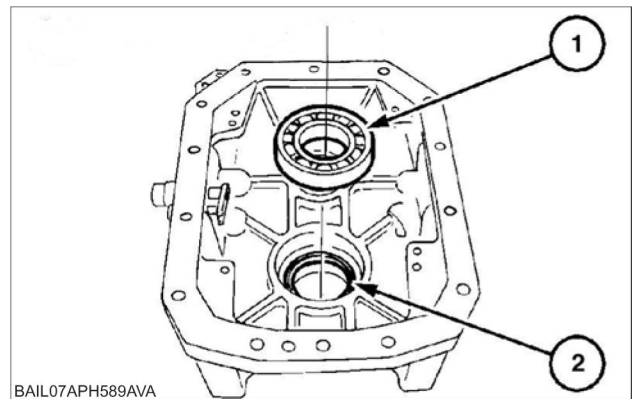

BAIL07APH589AVA

BAIL07APH589AVA 21

23. Remove the roll pin (1), remove selector lever (2) and remove the selector gate (3).

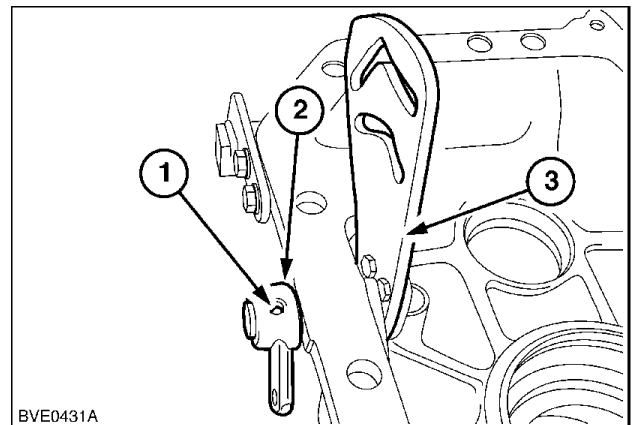

BVE0431A

BVE0431A 22

24. Remove the circlip (4), washer (3) sleeve (2) and the 750 RPM drive gear (1).

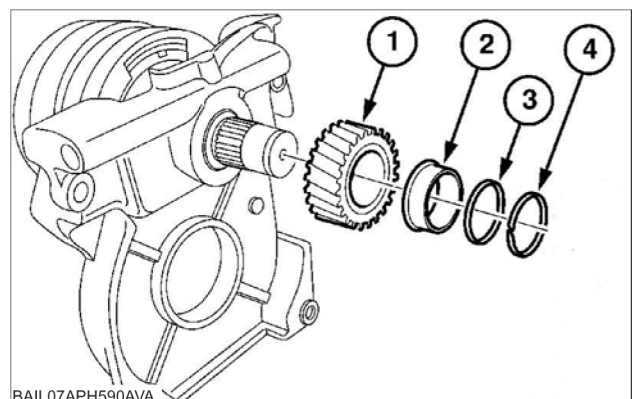

BAIL07APH590AVA

BAIL07APH590AVA 23

13. Install the lift link lower hinge pin and install the retaining pin.

NOTE: Repeat this step for the right-hand side.

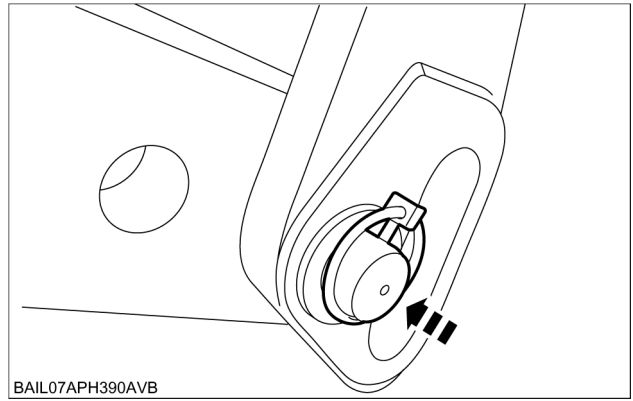

BAIL07APH390AVB 13

14. Install the EHC sensor retaining bolts.

NOTE: Repeat this step for the right-hand side.

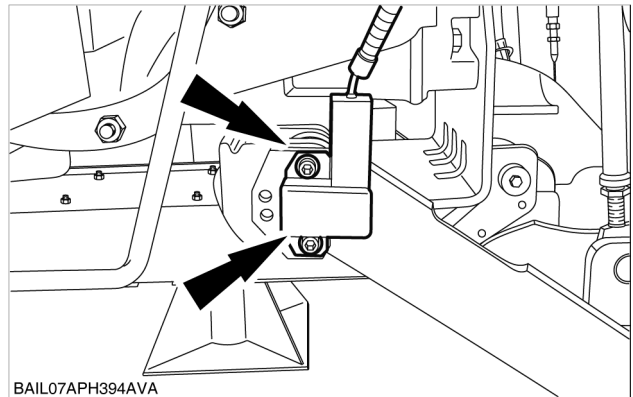

BAIL07APH394AVA 14

15. Locate the top lift link, install the pin (1), and retaining clip (2).

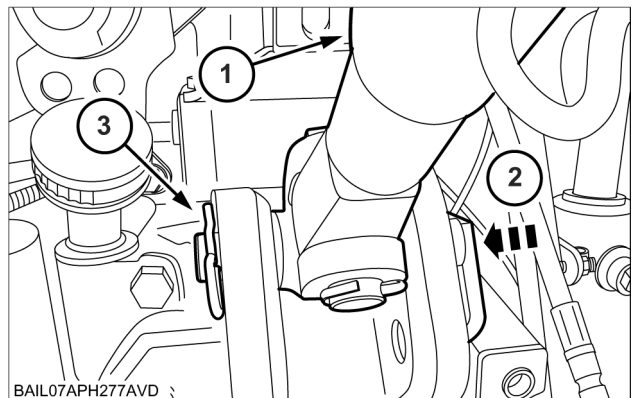

BAIL07APH277AVD 15

16. Fill the transmission with oil.

Next operation:

Connect the battery, for further information refer to **Battery - Connect (A.30.A)**

Front PTO Reduction Gearbox Exploded View.

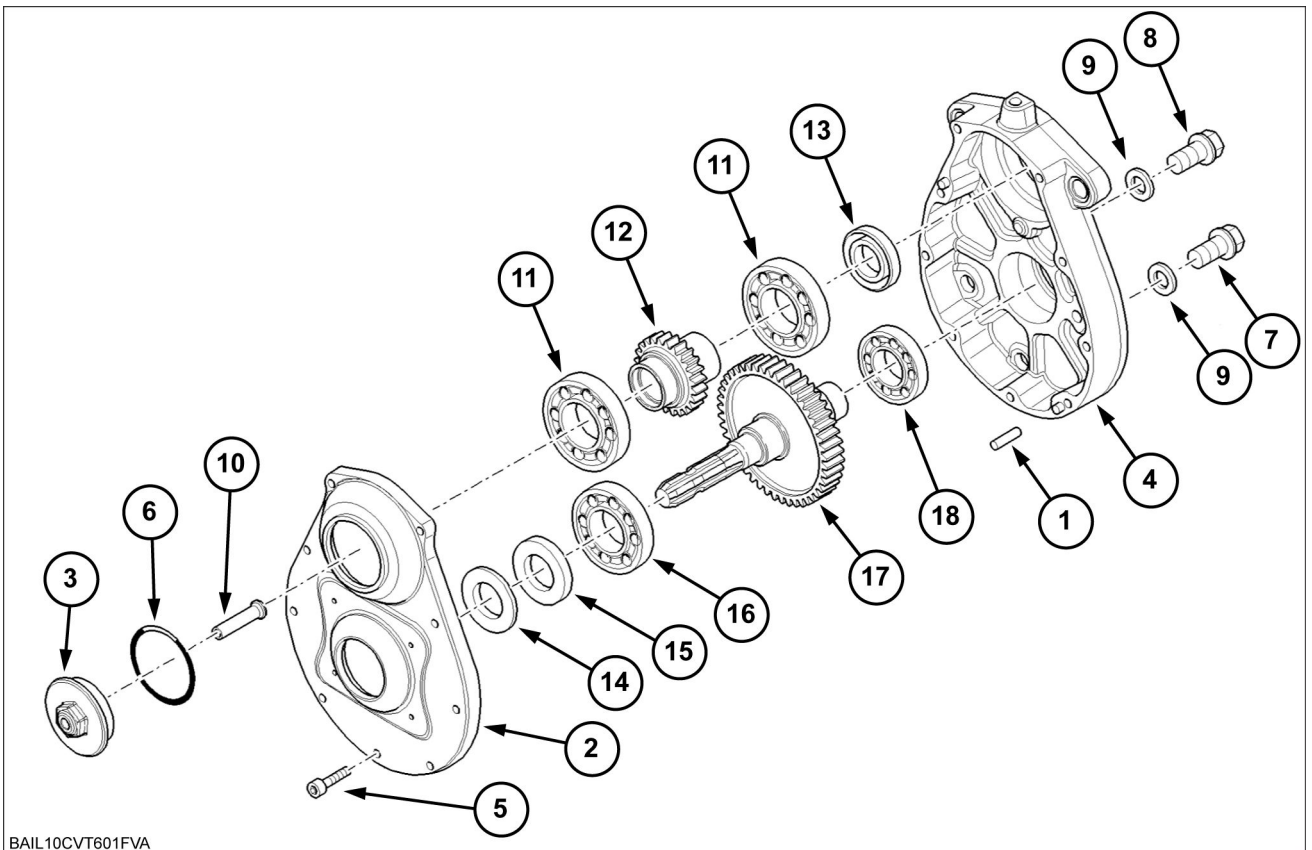

BAIL10CVT601FVA

BAIL10CVT601FVA 3

- | | |
|-------------------------|--------------------|
| 1. Dowel | 2. Housing cover |
| 3. Input shaft cover | 4. Housing |
| 5. Cover retaining bolt | 6. O-Ring |
| 7. Drain plug | 8. Filler plug |
| 9. Seal | 10. Tube |
| 11. Bearing | 12. PTO drive gear |
| 13. Seal | 14. Retainer |
| 15. Seal | 16. Bearing |
| 17. Output shaft | 18. Bearing |

Next operation:

Assemble the gearbox, for further information refer to **Gearbox - Assemble (C.42.C)**.

1. Remove the clutch release bearing cover (1) and the clutch release bearing (2).

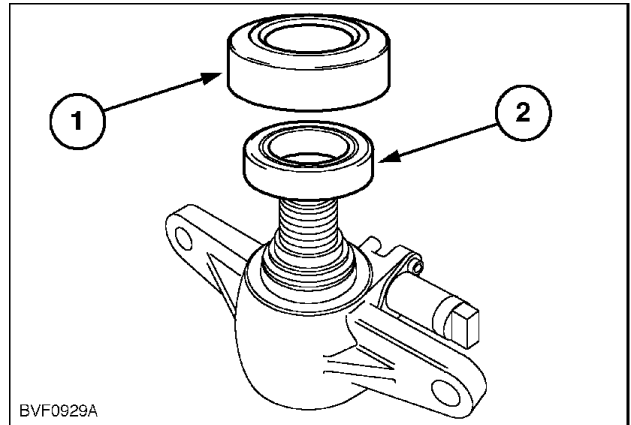

BVF0929A

BVF0929A 2

2. Rotate the piston housing **180 °**.
Using suitable circlip pliers, compress the circlip.

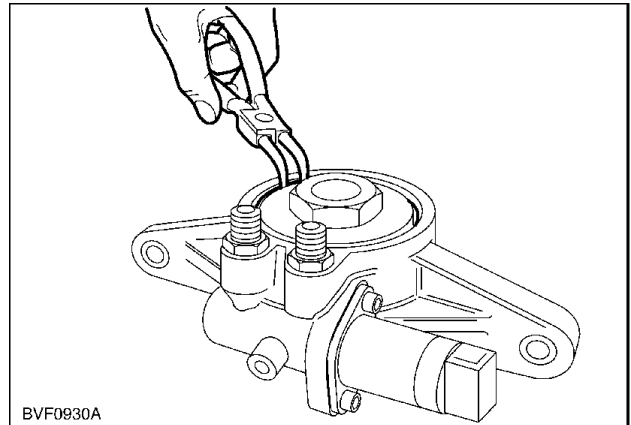

BVF0930A

BVF0930A 3

3. Remove the piston and spring assembly (1) from the piston housing.

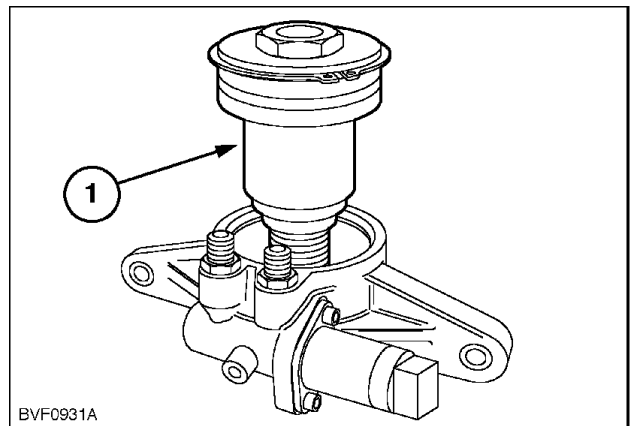

BVF0931A

BVF0931A 4

4. Remove the solenoid from the piston housing.

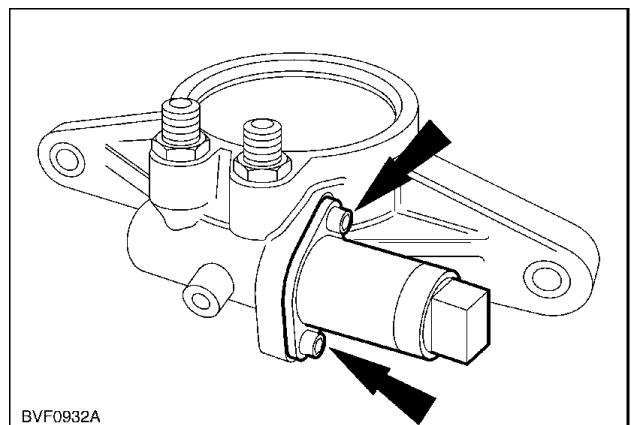

BVF0932A

BVF0932A 5

AXLES, BRAKES AND STEERING - FRONT AXLE

Cone point adjustment shims	mm	2.5 - 2.6 - 2.7 - 2.8 - 2.9 - 3.0 - 3.1 - 3.2 - 3.3 - 3.4 - 3.5 - 3.6 - 3.7
Pinion bearing adjustment shims	mm	2.50 - 2.55 - 2.60 - 2.65 - 2.70 - 2.75 - 2.80 - 2.85 - 2.90 - 2.95 - 3.00 - 3.05 - 3.10 - 3.15 - 3.20 - 3.25 - 3.30 - 3.35 - 3.40 - 3.45 - 3.50 - 3.55 - 3.60 - 3.65 - 3.70 - 3.75 - 3.80 - 3.85 - 3.90 - 3.95 - 4.00 - 4.05 - 4.10 - 4.15 - 4.20 - 4.25 - 4.30 - 4.35 - 4.40 - 4.45 - 4.50 - 4.55 - 4.60 - 4.65 - 4.70 - 4.75 - 4.80
Crown wheel point adjustment shims	mm	0.9 - 1.0 - 1.1 - 1.2 - 1.3 - 1.4 - 1.5 - 1.6 - 1.7 - 1.8 - 1.9 - 2.0
Side gear to differential gear backlash	mm	0.15
Differential gear thrust washer thickness	mm	1.470 - 1.530
Side gear thrust washer thickness	mm	1.4 - 1.5 - 1.6 - 1.7 - 1.8 - 1.9 - 2.0 - 2.1 - 2.2
Differential gear pin diameter	mm	23.939 - 23.960
Pin bore diameter on differential gears	mm	24.040 - 24.061
Pins to seats mounting clearance	mm	0.080 - 0.122
Side gear hub diameter	mm	43.961 - 44.000
Hub bore diameter on differential casing	mm	44.019 - 44.080
Side gears to seats mounting clearance	mm	0.019 - 0.119
Differential Lock Assembly (Dog Clutch)		
Free spring length	mm	approximately. 87
Compressed spring length, under a load of 1888 - 2035 N (424.4 - 457.5 lb)	mm	approximately. 48
Differential Lock Assembly (Multi-Wet Plate Clutch)		
Drive discs	mm	1.75 - 1.855
Drive discs	quantity	5
Driven discs	mm	2.35 - 2.45
Driven discs	quantity	6
Axle-Shafts and Swivel Assemblies		
Outer axle-shaft diameter at the bushings	mm	41.975 - 42.000
Press-fit bushing inner diameter	mm	42.100 - 42.175 (final dimension without reaming)
Axle-shafts to bushings mounting clearance	mm	0.100 - 0.200
Bushings to seats fitting interference	mm	0.064 - 0.129
Swivel pin bearing adjust shims	mm	0.10 - 0.15 - 0.20 - 0.25 - 0.30
Planetary Reduction Hubs		
Reduction ratio		16:(16+68) = 1:5.25
Planet gear thrust washer thickness	mm	0.77 - 0.83
Auto 4WD/Difflock		
Auto 4WD will disengage if:		Wheel speed > 20 km/h . When speed, 10 km/h and steering angle exceeds selected value. When the speed is between 10 - 20 km/h and the steering angle exceeds the selected value.
Auto Difflock will disengage if:		Wheel speed > 15 km/h . Wheel speed < 10 km/h and steering angle exceeds the selected value. When the speed is between 10 - 15 km/h and the steering angle exceeds the selected value. Rear hitch switch is pressed (1 second delay). One brake pedal is pressed (will re-engage when pedal is released).

12. Remove the front axle rear carrier retaining bolts.

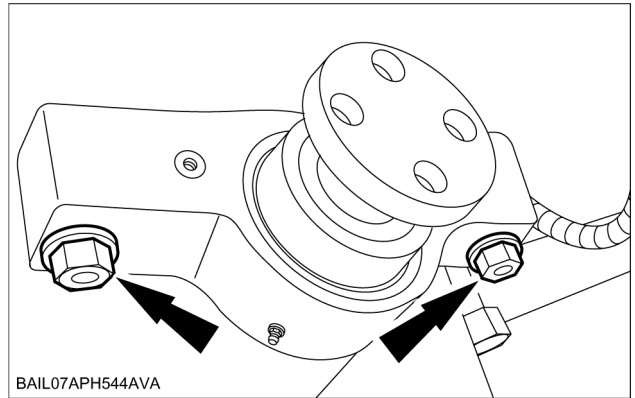

BAIL07APH544AVA 12

13. Remove the front axle front carrier retaining bolts.

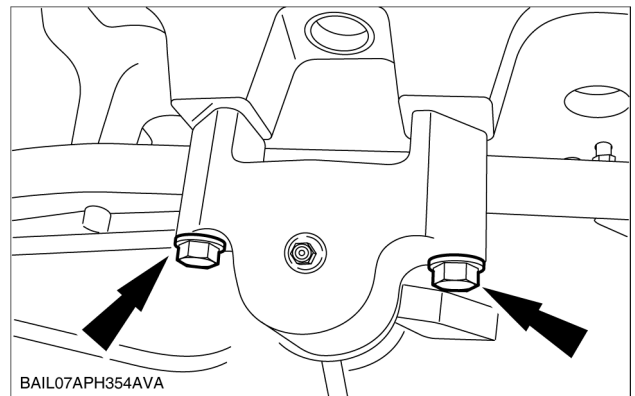

BAIL07APH354AVA 13

14. Lower the front axle.

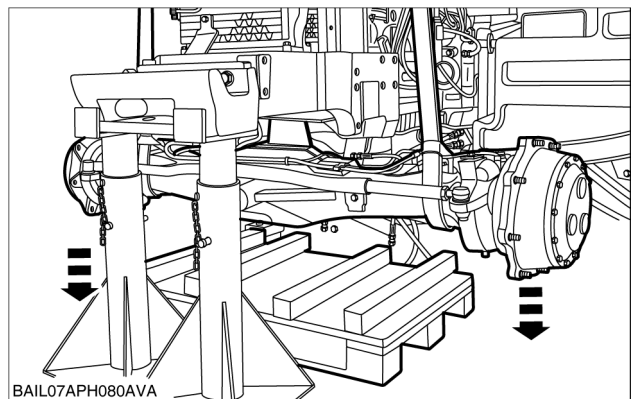

BAIL07APH080AVA 14

15. Remove the front axle from below the vehicle.

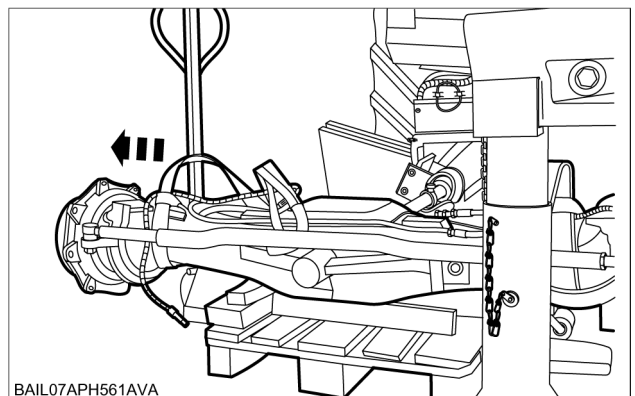

BAIL07APH561AVA 15

Differential - Disassemble (Class 3+ Axle)

Prior operation:

Disassemble the multi-plate differential lock clutch, for further information refer to **Differential lock - Disassemble (D.10.A)**.

⚠ **WARNING** ⚠

Handle all parts carefully. Do not put your hands or fingers between parts. Wear suitable safety clothing - safety goggles, gloves and shoes.

B026

- Using a suitable puller, remove the clutch pack cover bearing.

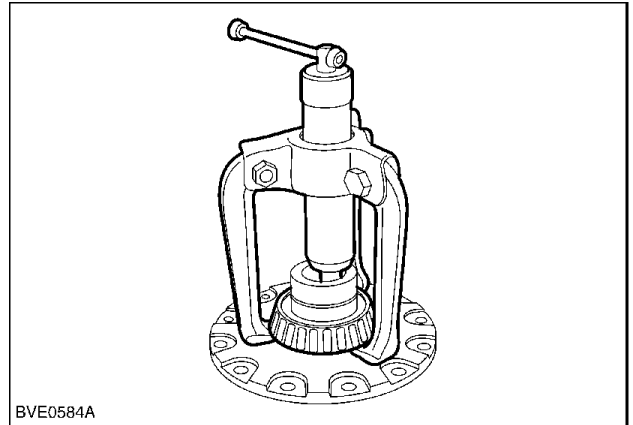

BVE0584A

BVE0584A 1

- Remove the thrust washer (1) and sun gear (2) from the differential cage (3).

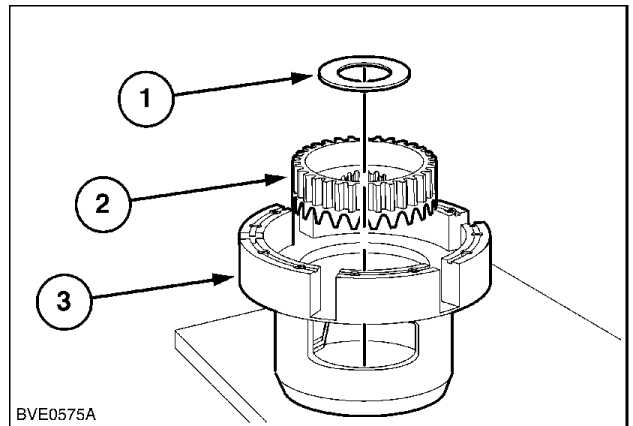

BVE0575A

BVE0575A 2

- Remove the crown wheel from the differential cage.

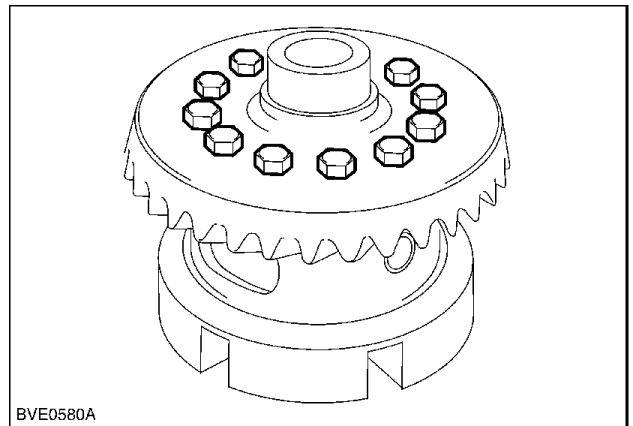

BVE0580A

BVE0580A 3

Bevel gear - Remove

suspended axle

1. Using a locally fabricated pinion flange holding tool, remove the pinion retaining nut and pinion flange.

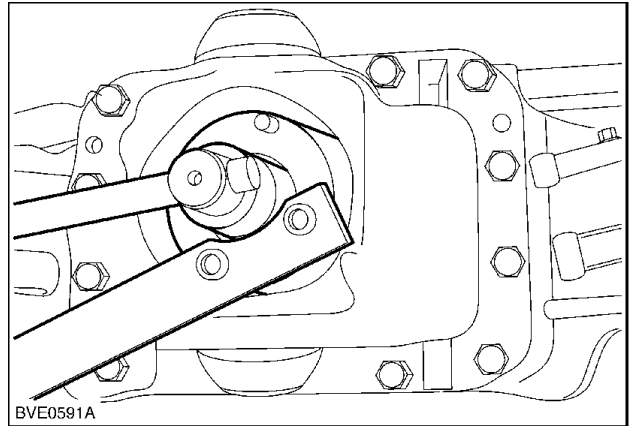

BVE0591A

BVE0591A 1

2. Remove the dust cover (1), pinion seal (2) and pinion bearing (3) from the differential casing.

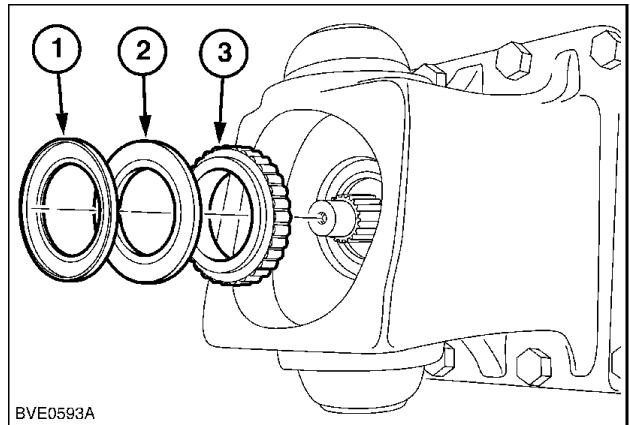

BVE0593A

BVE0593A 2

3. Withdraw the pinion shaft (1) from the rear of the differential casing and remove the spacer.

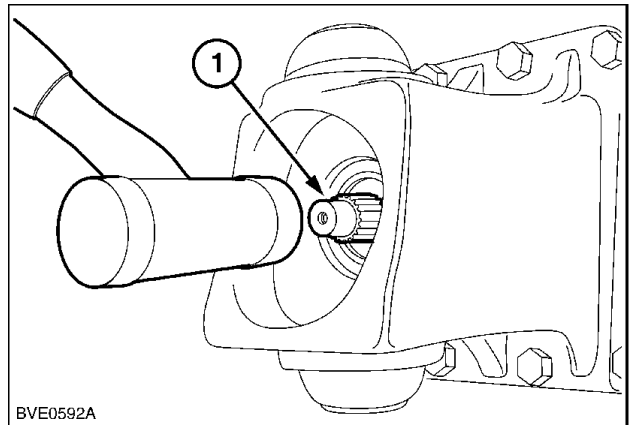

BVE0592A

BVE0592A 3

Next operation:
Bevel gear - Install (D.10.A).

8. Using the previously recorded measurements calculate the required thickness of the bearing preload adjustment shim to obtain measurement **(S)**.
 The bearing preload adjustment shim **(1)** will be calculated as follows:
 $(S) = L - L1 - C - G + 0.05\text{mm}$.
 For information on available shims refer to **FRONT AXLE - General specification (D.10.A)**.

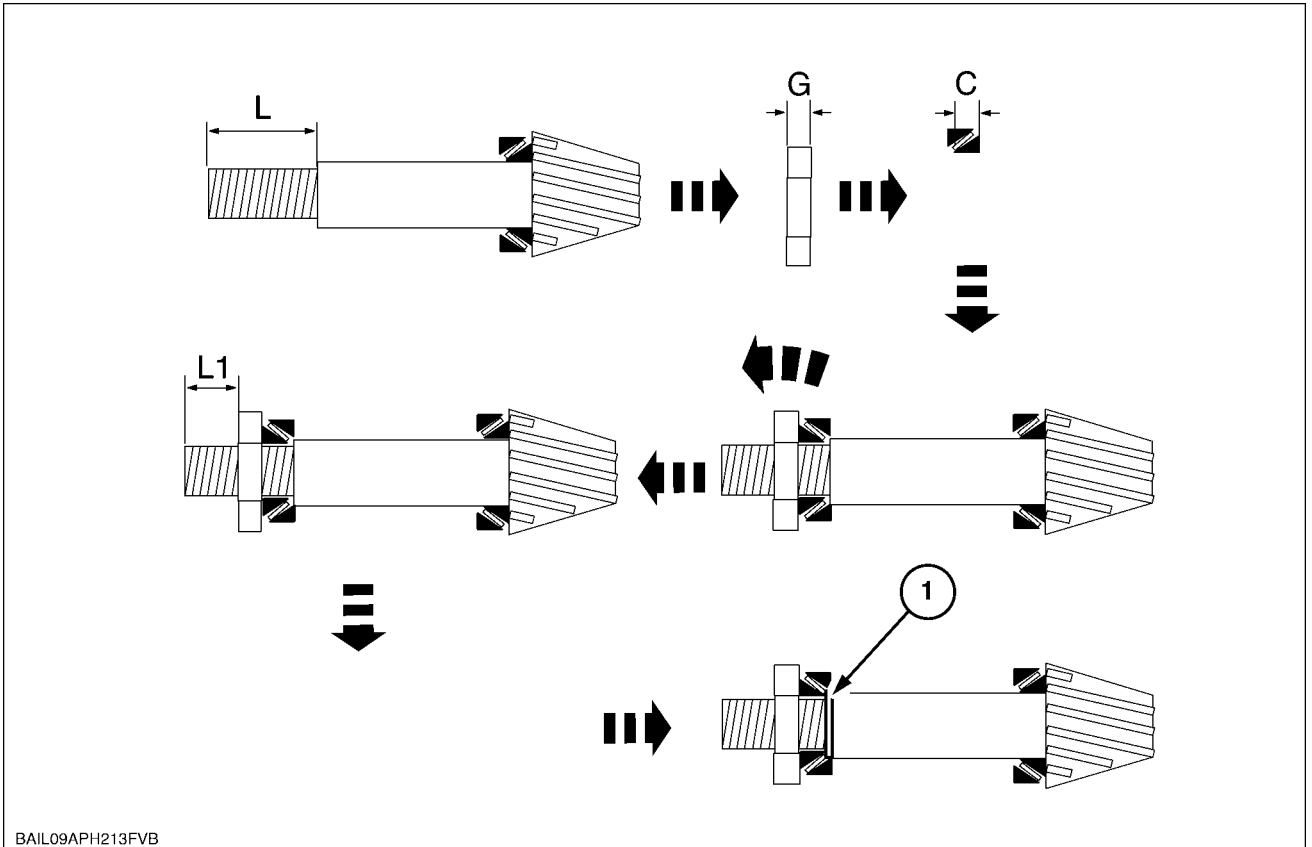

BAIL09APH213FVB 8

9. Remove the pinion shaft from the differential housing. Install the correct thickness preload adjustment shim **(1)** and reassemble the pinion shaft into the differential housing.
 Lubricate the bearings.
 Apply **LOCTITE® 243** to the threads of the pinion nut.

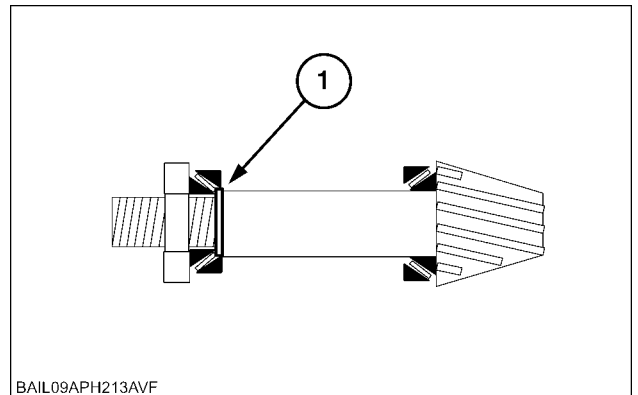

BAIL09APH213AVF 9

Housing - Disassemble

Prior operation:

Remove the steering cylinders, for further information refer to **Steering cylinder - Remove (D.20.C)**.

Prior operation:

Remove the differential, for further information refer to **Differential - Remove (D.10.A)**.

1. Remove the brass protection washer from the hub carrier.

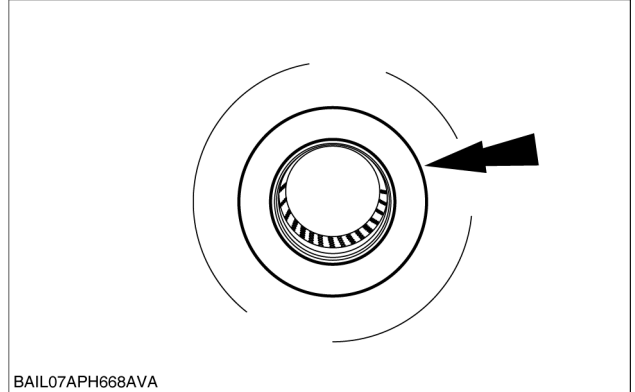

BAIL07APH668AVA 1

2. Remove the cassette seal.

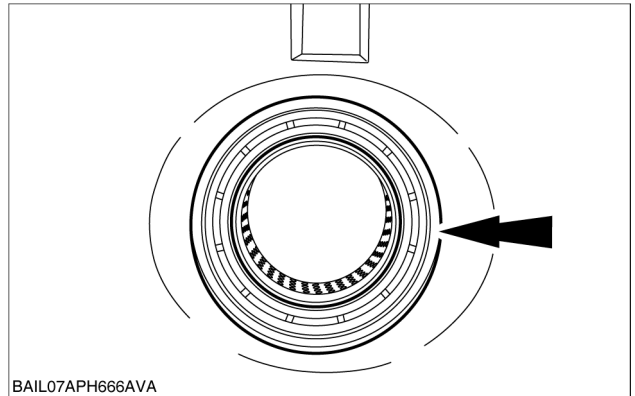

BAIL07APH666AVA 2

3. Remove the brass lubricating bushing.

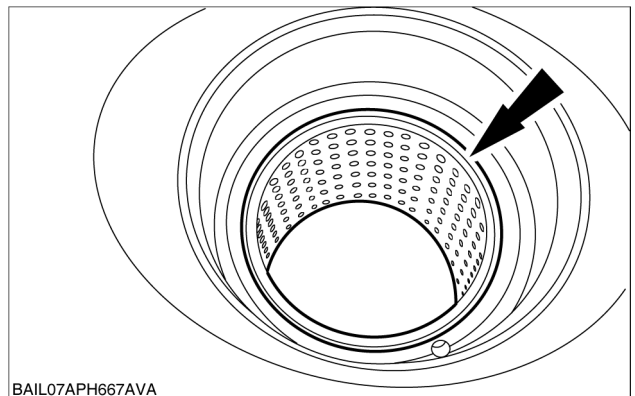

BAIL07APH667AVA 3

16. Remove the snap ring (1).
Remove the brake piston (2) from the brake disc carrier (3).

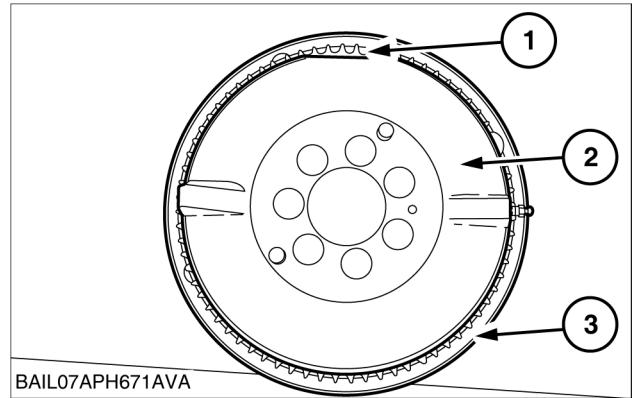

BAIL07APH671AVA 16

17. Remove the oil seal (1).
Remove the bearing assembly (2).

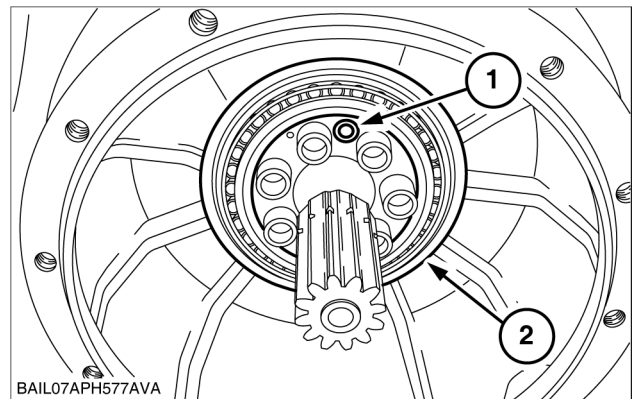

BAIL07APH577AVA 17

18. Using suitable lifting equipment, support the hub.
Using a suitable puller, remove the hub.

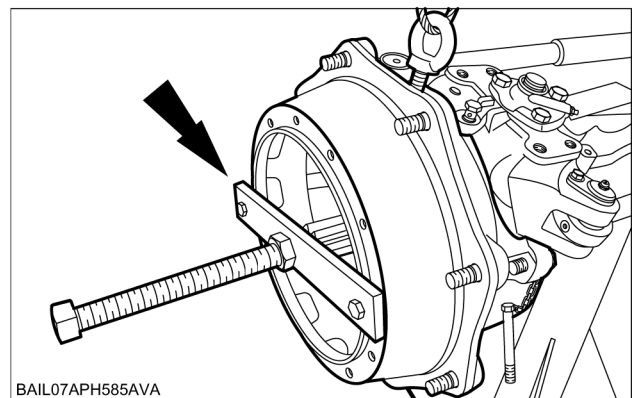

BAIL07APH585AVA 18

19. Remove the cassette seal.

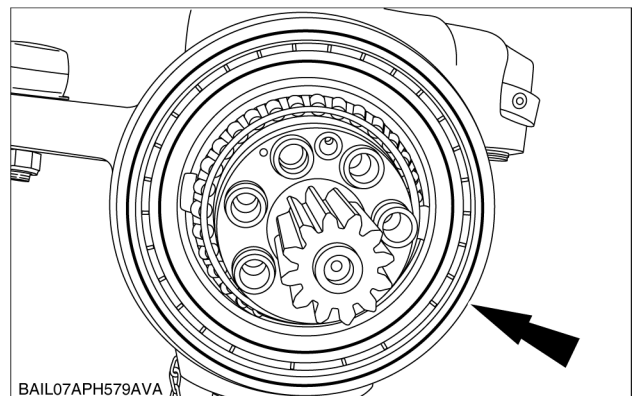

BAIL07APH579AVA 19

Contents

AXLES, BRAKES AND STEERING - D

REAR AXLE - 12.A

TECHNICAL DATA

REAR AXLE	
Torque	3
Special tools	4
General specification	6

FUNCTIONAL DATA

REAR AXLE	
Sectional view	8
Static description	10

SERVICE

REAR AXLE	
Adjust	11
Final drive	
Reducer, spur gear - Overhaul	21
Shaft - Remove	23
Shaft - Install	25
Differential	
Overhaul	27
Differential lock	
Multi plate clutch - Overhaul	31

DIAGNOSTIC

REAR AXLE	
Troubleshooting	36

Final drive Shaft - Install

Prior operation:

Final drive Shaft - Remove (D.12.A)

1. Install the drive shaft into the final drive housing.
2. Install the thrust washer.

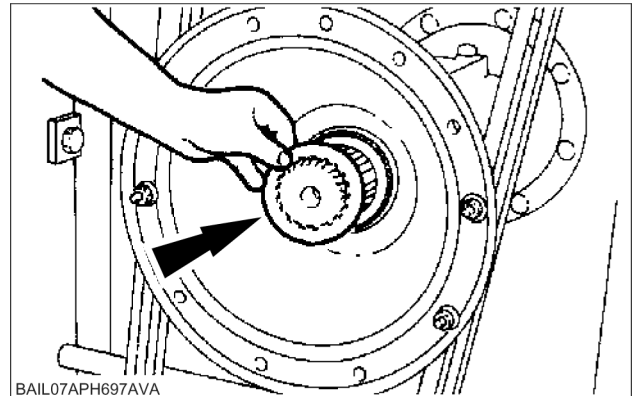

BAIL07APH697AVA 1

3. Install the planetary gear carrier.

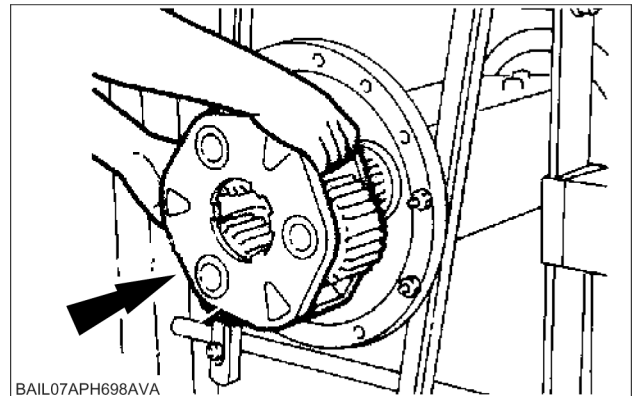

BAIL07APH698AVA 2

4. Turn the drive shaft by hand and check that it turns freely.
Tighten the drive shaft bolt to **196 Nm (145 lb ft)** while turning the drive shaft to settle the assembly.
Loosen the drive shaft bolt and then tighten it again to **88 Nm (65 lb ft)** while turning the drive shaft to settle the bearings correctly.

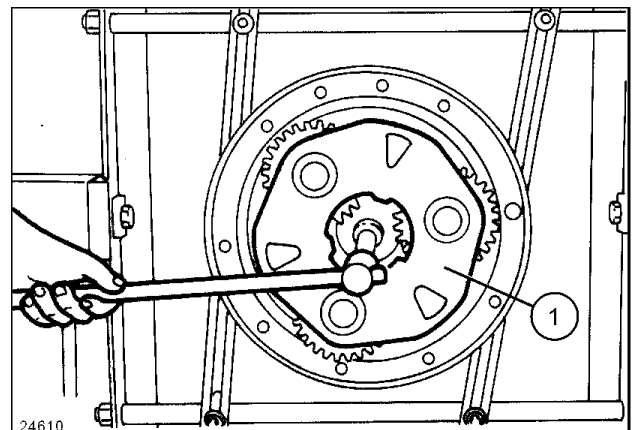

24610_553 3

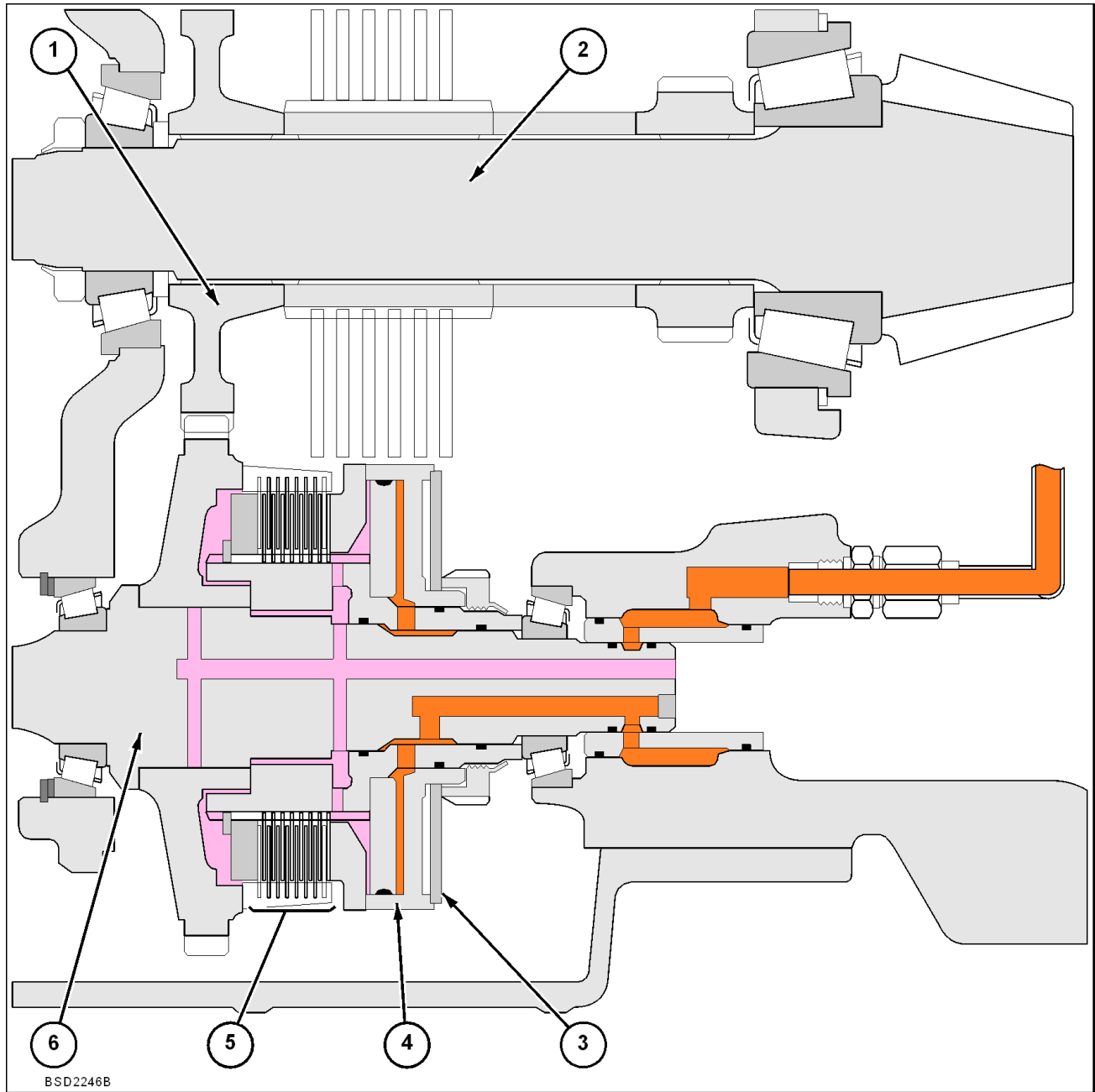

BSD2246B 4

Lubrication oil



Lubrication oil



Pressure oil

FWD ELECTRO-HYDRAULIC CLUTCH (FWD DISENGAGED)

When the switch located on the ICP panel is pressed, the solenoid valve opens and lets the oil flow from the pump to the face of the control piston **(4)**.

The pressure oil applied to the face of the piston moves the piston body against the action of the Belleville spring **(3)** and releases the spring pressure applied to the clutch plates **(5)**.

Under these conditions, the clutch plates **(4)** are not compressed and the clutch shaft **(6)** can rotate freely preventing the transfer of drive to the front axle.

17. Support the suspension arm on suitable axle stands and remove the lifting equipment from the suspension arm.

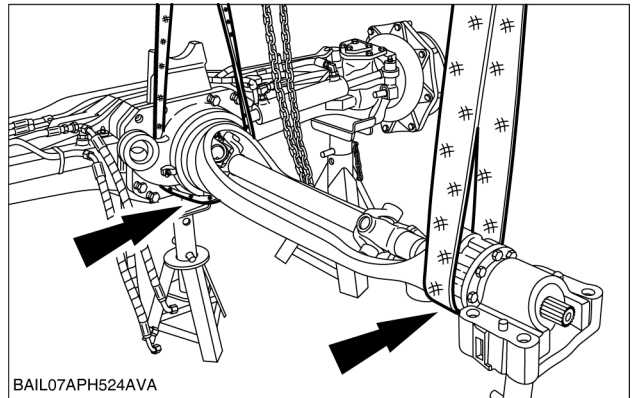

BAIL07APH524AVA 17

18. Install the suspension arm retaining bolts. Tighten to **275 Nm (203 lb ft)**.

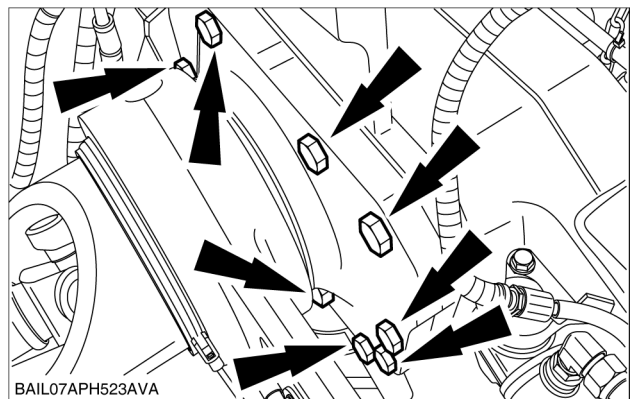

BAIL07APH523AVA 18

4. Remove rear PTO housing

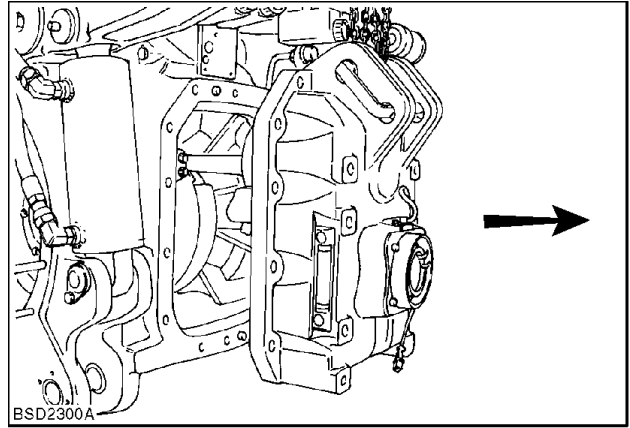

BSD2300A 4

5. The rear of the 4wd clutch shaft can now be accessed.

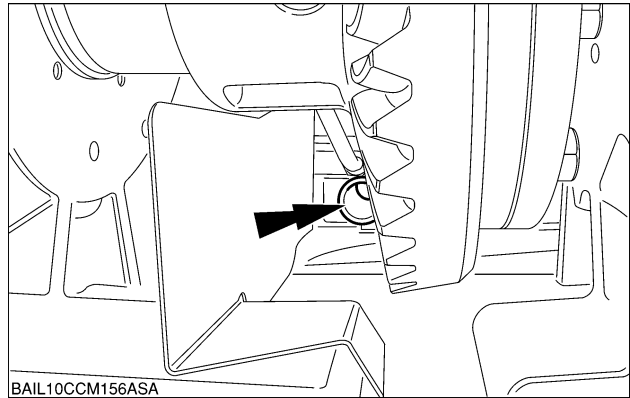

BAIL10CCM156ASA 5

6. Remove the rear axle sump.

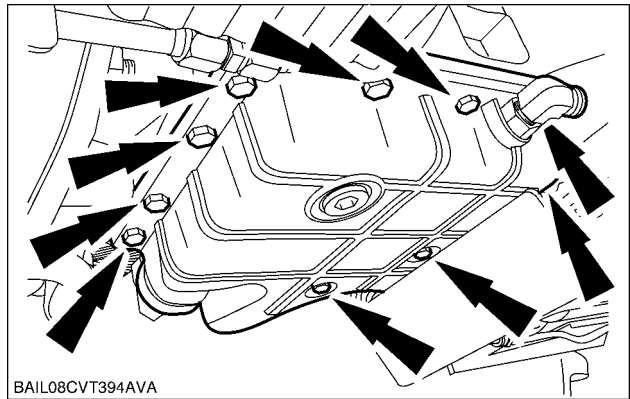

BAIL08CVT394AVA 6

7. Remove inner clutch guard.

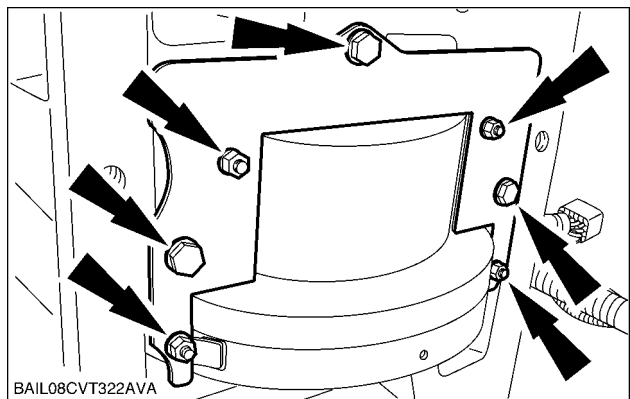

BAIL08CVT322AVA 7



AXLES, BRAKES AND STEERING - D

STEERING Hydraulic - 20.C

**PUMA 130 CVX , PUMA 130 , PUMA 145 CVX , PUMA 145 , PUMA 160 CVX
 , PUMA 160**

Contents

AXLES, BRAKES AND STEERING - D

STEERING Autoguidance - 20.E

FUNCTIONAL DATA

STEERING Autoguidance

Static description Auto guidance system	3
Dynamic description Autoguidance system	5
Hydraulic schema Autoguidance system	8

SERVICE

Control valve

Remove	9
Install	11



AXLES, BRAKES AND STEERING - D

SERVICE BRAKE Pneumatic - 30.E

**PUMA 130 CVX , PUMA 130 , PUMA 145 CVX , PUMA 145 , PUMA 160 CVX
 , PUMA 160**

Contents

AXLES, BRAKES AND STEERING - D

PARKING BRAKE Electronic - 32.D

FUNCTIONAL DATA

PARKING BRAKE Electronic	
Dynamic description	3

SERVICE

PARKING BRAKE Electronic	
Remove	6
Install	8
Adjust	10

BRAKE CONNECTION Hydraulic - Testing

NOTE: Trailer Brakes Not Working

N°	Test Point	Expected Result	Other Result (Possible Cause)
1	Condition Has all air been bled from trailer brakes	Result YES Action Go to test 2	Action NO Bleed trailer brakes refer to SERVICE BRAKE Hydraulic - Bleed (D.30.C)
2	Condition Pressure test trailer brakes. Fault confirmed?	Result YES Action Go to test 3	Action
3	Condition Is hydraulic lift working satisfactorily? Test maximum system pressure at remote valve coupler. Pressure 2900 - 3000 lbf/in² (200 - 207 bar) ?	Result YES Action Go to test 4	Action NO Go to test 5
4	Condition Operate and hold remote valve to generate maximum system pressure and at the same time operate tractor brakes Trailer brake valve functions correctly?	Result YES Action Go to test 6	Action NO Replace trailer brake valve
5	Condition Adjust flow/pressure compensating valve Fault cleared?	Result	Action NO Go to test 7
6	Condition Examine shuttle valve in load sensing line between trailer brake and pressure/flow compensating valve Valve sticking?	Result YES Action Clean/replace shuttle valve to trailer brake valve	Action
7	Condition Examine flow/pressure compensating valve for sticking Fault cleared?	Result	Action NO Disassemble variable flow pump and check swash plate piston for sticking

Contents

AXLES, BRAKES AND STEERING - D

WHEELS AND TRACKS Wheels - 50.C

TECHNICAL DATA

Front wheel	
Torque	3

Engine hood - Install

1. Using a suitable hoist, lower the hood onto the vehicle.

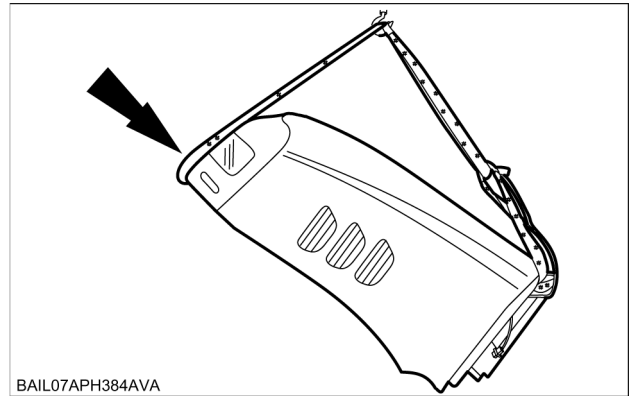

BAIL07APH384AVA 1

2. Install the two hood retaining bolts.

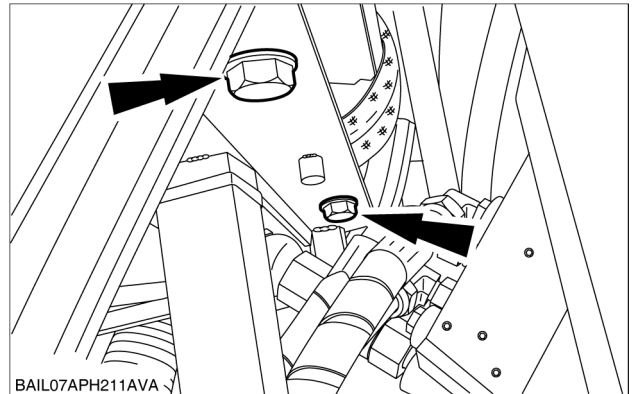

BAIL07APH211AVA 2

3. Release the rear of the hood from the hoist.

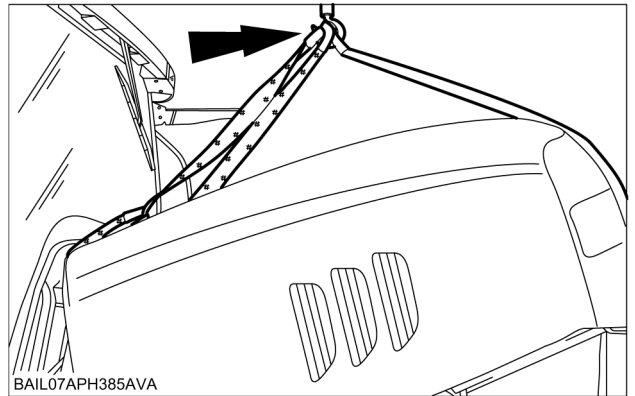





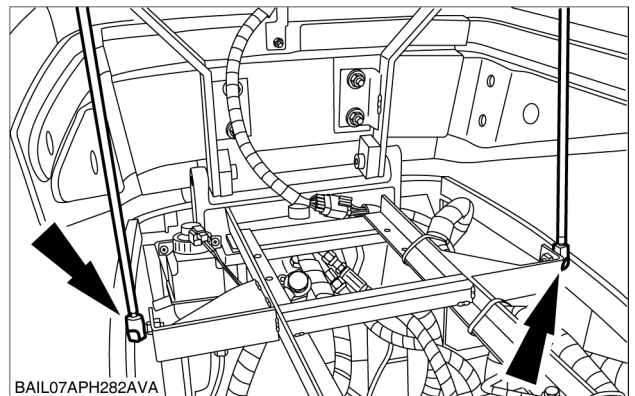

BAIL07APH385AVA 3



4. Connect the lower ends of the hood support struts.









BAIL07APH282AVA 4

Symbol on display	Indicator light	Warning light	Acoustic warning	Cause	Signal
 HYDRO OIL PRESSURE WARNING 	-	 flashes	Critical	Hydraulic oil pressure for hydrostat too low < 16 bar (232 psi) : Automatic engine shutdown function is activated and shuts down in 5 s or 30 s - see Control module Instrument controller - H3 - Configurations and options (A.50.A) .	CAN message from UCM CAN message from TCM
 HYDRO OIL FILTER BLOCKED	-	 flashes 4 s/ illuminates	-	Suction filter for hydraulic oil blocked: Oil temperature > 40 °C (104 °F) Underpressure > 473 mbar	Ground *S-028 (*S-028 switch for soiled hydraulic oil filter underpressure)
 HYDRO OIL FILTER BLOCKED	-	 flashes 4 s/ illuminates	-	Filter for hydrostat feed pump blocked: (only with CVT transmission)	*B100 pressure sensor, vane pump

Steering

Symbol on display	Indicator light	Warning light	Acoustic warning	Cause	Signal
 STEERING OIL PRESSURE TOO LOW	-	 flashes/ illuminates	Critical	Servo-steering pressure too low: Servo-steering pressure < 11 bar (159.5 psi) . (Only with CCLS steering system)	*S-086 servo-steering pressure switch

Engine

Symbol on display	Indicator light	Warning light	Acoustic warning	Cause	Signal
 ENGINE OIL PRESSURE VERY LOW	 flashes/ illuminates	 flashes/ illuminates	Critical	Engine oil pressure too low: Automatic engine shutdown function is deactivated (NO).	CAN message from EDC
 ENGINE OIL PRESSURE VERY LOW 		 flashes	Critical	Engine oil pressure too low: Automatic engine shutdown function is activated and shuts down in 5 s or 30 s . - see Control module Instrument controller - H3 - Configurations and options (A.50.A) .	CAN message from EDC

46. Raise the rear of the tractor and remove the axle stands (1).

NOTE: If detached during removal, reattach the lift rods to the lower links.

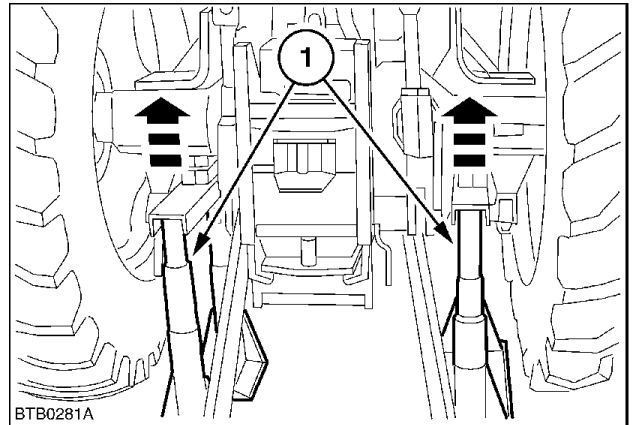

BTB0281A 46

47. Remove the wooden wedges from between the front axle and front support.

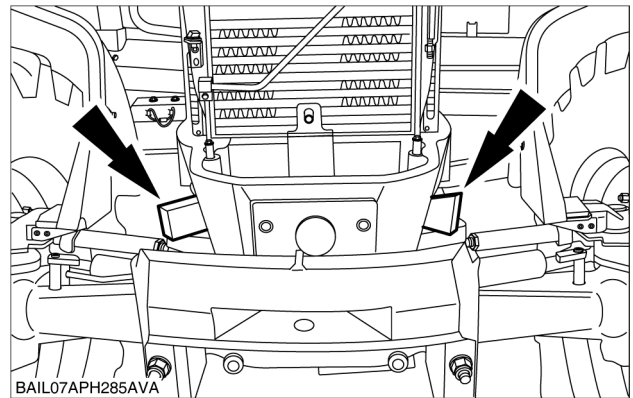

BAIL07APH285AVA 47

48. Remove the wheel stops from the front wheels.

Next operation:

Fill the engine coolant system, for further information, refer to **ENGINE COOLANT SYSTEM - Filling (B.50.A)**.

Next operation:

Bleed the brake system, for further information, refer to **SERVICE BRAKE Hydraulic - Bleed SERVICE BRAKE Hydraulic - Bleed (D.30.C)**.

Next operation:

Connect the battery, for further information, refer to **Battery - Connect (A.30.A)**.

PERFORMANCE TEST EXAMPLE 9

- 1 High Side Low
- 2 High Side Hand Valve Closed
- 3 High Side Hose Connected to High Side Service Connector
- 4 Not Used
- 5 Low Side Hose Connected to Low Side Service Connector
- 6 Low Side Hand Valve Closed
- 7 Low Side Low

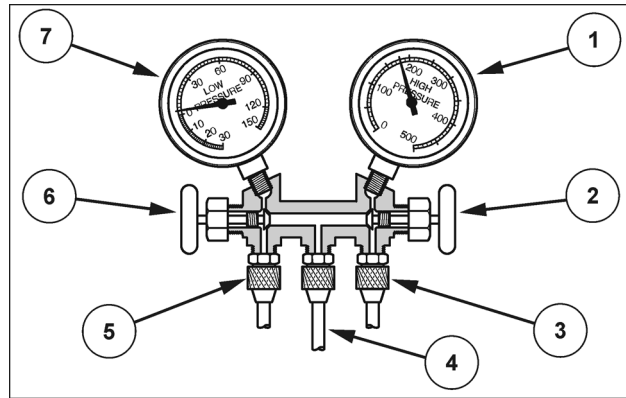

SS11E033 9

PROBLEM:

Insufficient cooling.

CAUSE:

Restriction in high side of system.

CONDITIONS*

Low side pressure too low. Gauge should read **1 - 2 bar (15 - 29 psi)**.

High side pressure too low. Gauge should read **16 - 18 bar (232 - 261 psi)**.

NOTE: A normal or high reading of the high side pressure gauge under these conditions indicates the system is overcharged or the condenser or receiver/dryer is too small.

Evaporator only slightly cool.

Liquid line and receiver/dryer are cool to touch and show frost or considerable moisture.

CORRECTIVE PROCEDURES

1. Discharge and recover the refrigerant from the system.
2. Replace the liquid lines, receiver/dryer, or other obstructed components.
3. Evacuate the system.
4. Charge the system.
5. Performance test the system.

DIAGNOSIS: Restriction in the liquid line and/or receiver/dryer resulting in a "starved" evaporator (compressor moving refrigerant from the evaporator faster than it can enter).

NOTE: Test procedure based upon ambient temperature of **35 °C (95 °F)**. For proper high side gauge reading for other ambient temperatures, refer to the pressure temperature chart **ENVIRONMENT CONTROL Heating, ventilation and air-conditioning - Service instruction (E.40.D)**.

Checking the function of the air conditioning system

10. The pressure gauge battery is the most important tool when checking and performing maintenance on the air conditioning system.
If the workshop has a modern automatic suction, evacuation, recycling and filling device the pressure gauges are already installed inside them.
The following instructions for checking the function of the air conditioning system apply to the pressure gauge battery shown in the diagram. The system check using a suction and filling device with pressure gauges fitted basically follows the same process.
When using such devices, always note the operating instructions provided by the manufacturer.
11. Notes for accident prevention
In the closed valves the refrigerant flows around the valve stems to the pressure gauges. As a result, after connecting the pressure battery the pressure is shown by both pressure gauges.
NEVER screw open the manual shut- off valve on the PRESSURE SIDE while the system is in operation.
ALWAYS screw open the manual shut- off valve on the SUCTION SIDE when the refrigerant is being topped up.

NOTE: Always ensure that the manual shut- off valves are screwed shut during all of the testing steps (clockwise, to the stop).

12. Connection of pressure gauge battery to vehicle
Always ensure that the manual shut- off valves of the pressure gauge battery are screwed shut (clockwise, to the stop).
13. Connect the hose of the high pressure gauge (usually red) to the pressure side shut- off valve, and the hose of the low pressure gauge (usually blue) to the suction side connection valve at the vehicle, see the diagram. Ensure that the hose fittings have been perfectly tightened.

NOTE: Prior to connecting the pressure gauge battery determine the assignment of the connections for the high pressure gauge (pressure side) and the low pressure gauge (suction side). The pressure side connection valve always sits in the line from the cooling compressor to the condenser.

14. The connection valves for the high pressure and low pressure sides on the vehicle are spring-loaded valves and open automatically when the pressure testing hose is connected.
The connection valves are closed with a protective cap. Remove this cap prior to connecting the pressure gauge and fit it again when the servicing of the vehicle is complete.

NOTE: A suitable pressure pin must be inserted into the pressure testing pipe to actuate this type of valve.

Command Switch - Replace (Modes of operation)

1. Turn the starter switch to the "OFF" position.
Remove the facing.

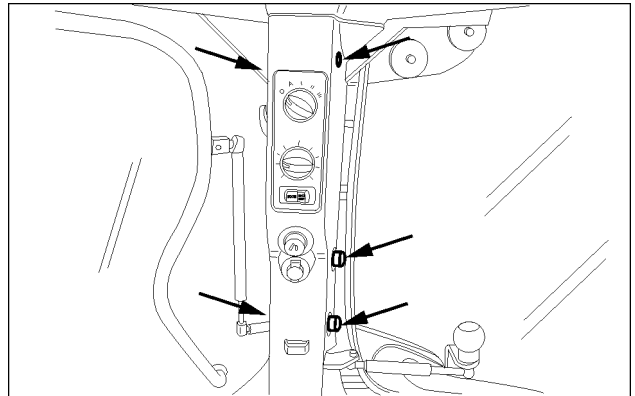

SS08D010 1

2. Standard air conditioner design:
Remove the plug at the switch.
Replace the switch (1).

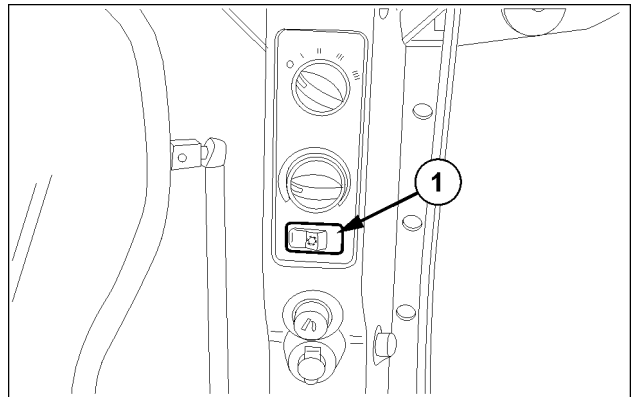

SS08D013 2

- Automatic air conditioner (ATC) design:
Remove the plug at the switch.
Replace the switch (1).

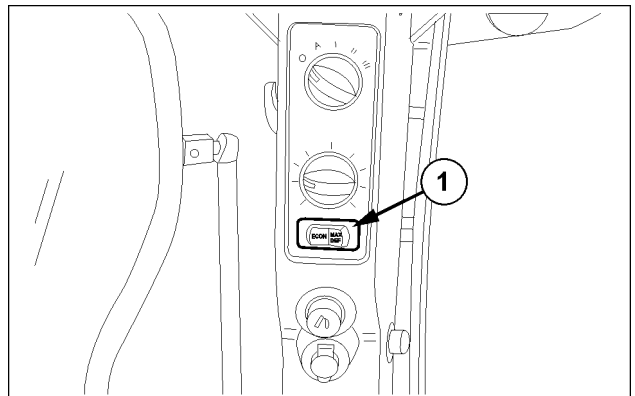

SS08D012 3

3. Insert the plug at the switch (1).
4. Install the facing.

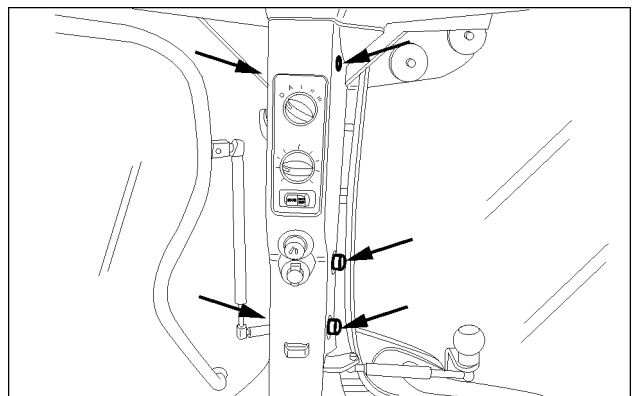

SS08D010 4

Assembly

- Standard air conditioner design:
Insert the evaporator (2). Fit the evaporator temperature sensor (1).

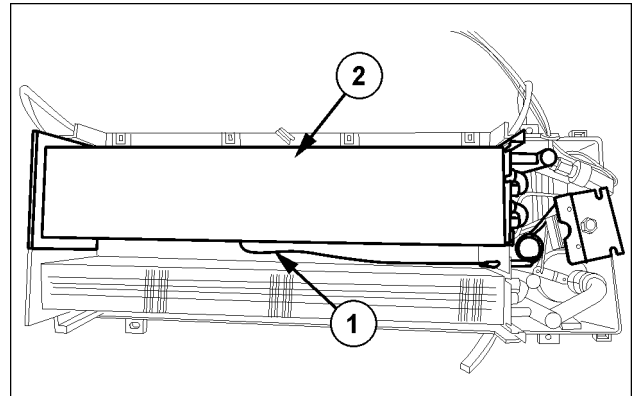

- Automatic air conditioner (ATC) version:
Insert the evaporator (2). Fit the evaporator temperature sensor (3).

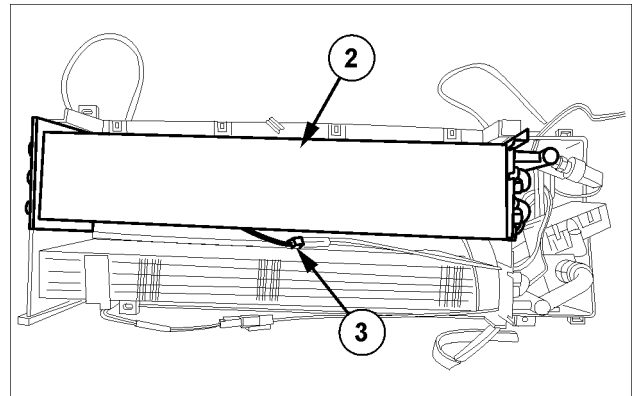

- Fit the top part of the housing.
Attach the four retaining clips to the housing. Place the rear air duct and screw in the mounting screws.

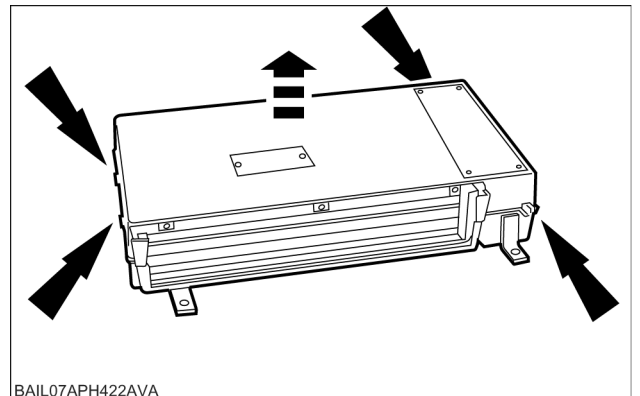

Next operation:

Install the heating and air conditioning unit - see **ENVIRONMENT CONTROL Heating, ventilation and air-conditioning - Install (E.40.D)**.

Sensing system - Replace (High pressure/low pressure switch)

NOTE: You do not need to drain off the refrigerant in order to replace the pressure switch.

1. Turn the starter switch to the "OFF" position.
Disconnect the connector.
Unscrew the switch from the self-closing valve.

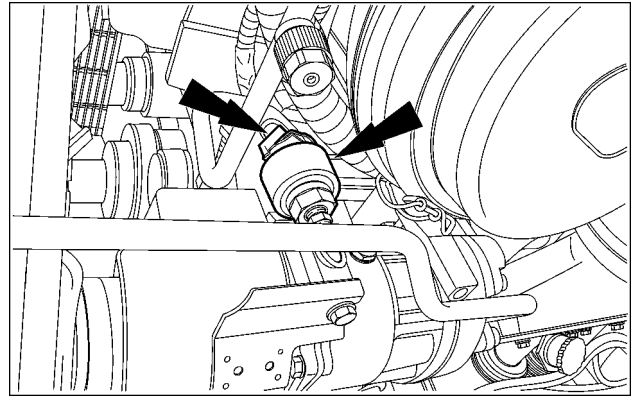

SS11D401 1

2. Screw in the pressure switch.
Connect the connector to the pressure switch.

HITCH Front hitch - Static description

NOTE: The three point front hitch is an option which may be fitted during manufacture, or as a dealer installed accessory. Whichever option is fitted the principles of operation described here apply to both.

⚠ WARNING

Entanglement hazard!

Extreme care must be exercised when adjusting and checking hitch and control linkage when the engine is running and when linkage is hydraulic or mechanical load. Study the linkage and hitch travel. Keep the hands, arms, legs, and feet out of the travel arc of the hitch and linkage.

Failure to comply could result in death or serious injury.

W0116A

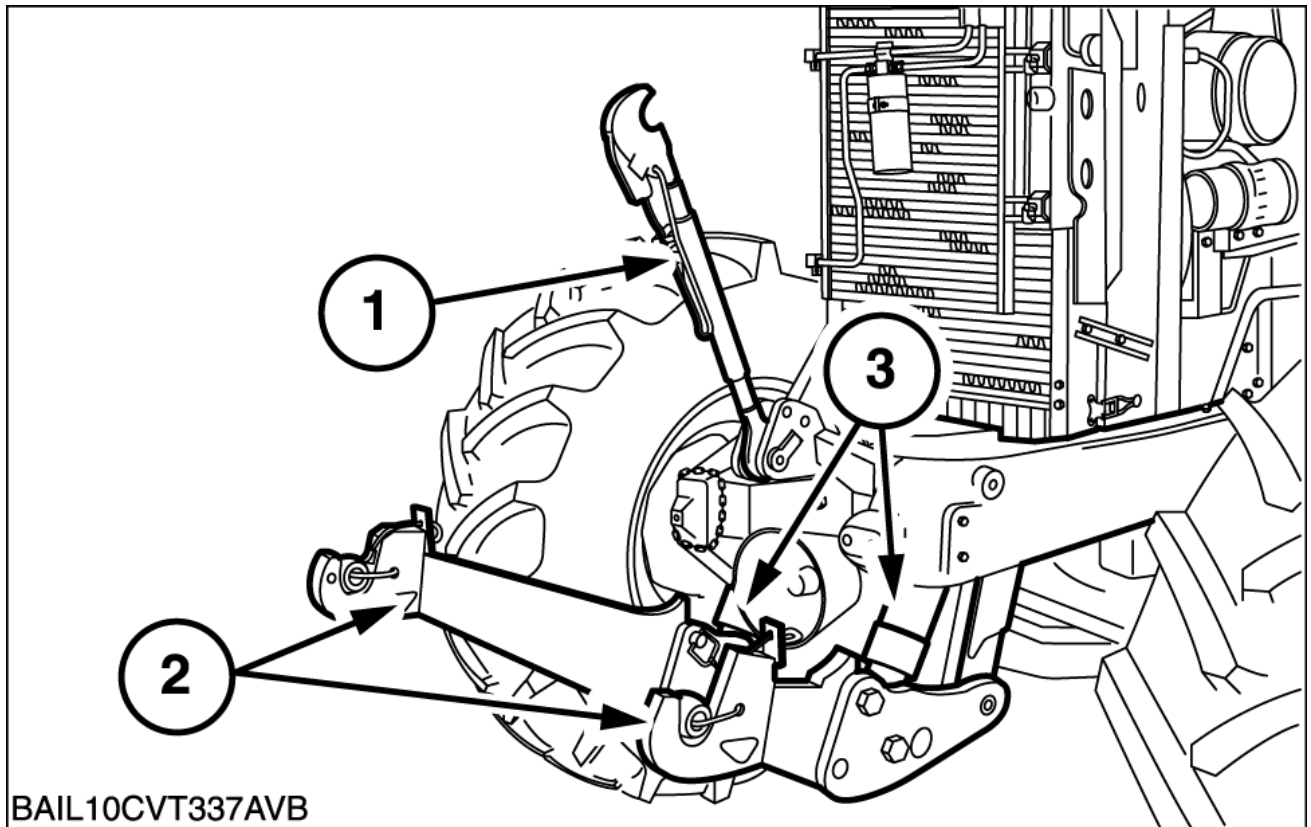

BAIL10CVT337AVB 1

The front hitch consists of an adjustable top link (1) a pair of folding lower links (2) and two large double action cylinders (3). The top link and lower links have open claw ends that permit rapid coupling and uncoupling of implements. The claws are equipped with self-locking latches to make sure that there is positive retention of the 3 point hitch to the implement. The two large double-action cylinders provide maximum lifting power throughout the entire lifting range. The front hitch may be operated by using the electronic rear remote or mid-mount valves (if fitted).

9. Remove lower frame left-hand pivot pin (1).
Remove the shims (2).
Repeat step for the right-hand side.

NOTE: Note the position of the shims when removing to aid installation.

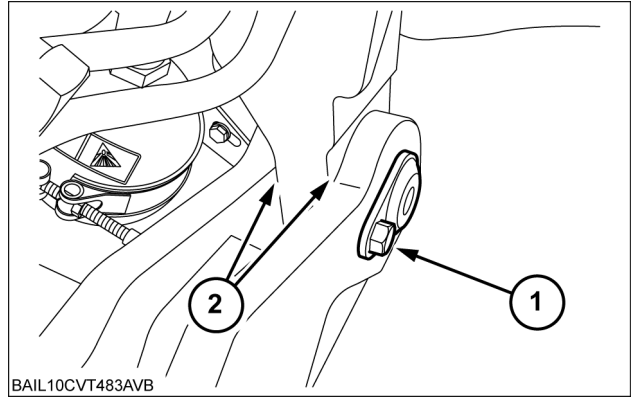

BAIL10CVT483AVB 8

10. Remove the lower frame

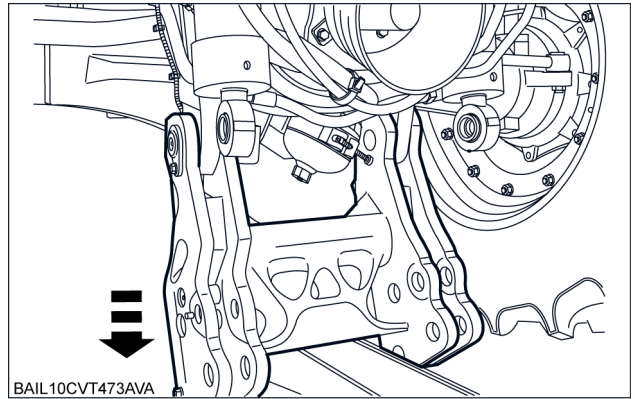

BAIL10CVT473AVA 9

CLICK HERE TO **DOWNLOAD** THE COMPLETE MANUAL

- Thank you very much for reading the preview of the manual.
- You can download the complete manual from: www.heydownloads.com by clicking the link below



- Please note: If there is no response to CLICKING the link, please download this PDF first and then click on it.

CLICK HERE TO **DOWNLOAD** THE COMPLETE MANUAL