

DV209B
Tier 3
Double Drum Compactor
PIN DDDD209BNGNT52033 and above

SERVICE MANUAL

Part number 48038047
1st edition English
August 2016



CLICK HERE TO **DOWNLOAD** THE COMPLETE MANUAL

- Thank you very much for reading the preview of the manual.
- You can download the complete manual from: www.heydownloads.com by clicking the link below



- Please note: If there is no response to CLICKING the link, please download this PDF first and then click on it.

CLICK HERE TO **DOWNLOAD** THE COMPLETE MANUAL

INTRODUCTION

Operate controls only when seated in the operator's seat, except for those controls expressly intended for use from other locations.

METRIC FLANGED HARDWARE

NOM. SIZE	CLASS 8.8 BOLT and CLASS 8 NUT		CLASS 10.9 BOLT and CLASS 10 NUT		LOCKNUT CL.8 W/CL8.8 BOLT	LOCKNUT CL.10 W/CL10.9 BOLT
	UNPLATED	PLATED W/ZnCr	UNPLATED	PLATED W/ZnCr		
M4	2.4 N·m (21 lb in)	3.2 N·m (28 lb in)	3.5 N·m (31 lb in)	4.6 N·m (41 lb in)	2.2 N·m (19 lb in)	3.1 N·m (27 lb in)
M5	4.9 N·m (43 lb in)	6.5 N·m (58 lb in)	7.0 N·m (62 lb in)	9.4 N·m (83 lb in)	4.4 N·m (39 lb in)	6.4 N·m (57 lb in)
M6	8.3 N·m (73 lb in)	11 N·m (96 lb in)	12 N·m (105 lb in)	16 N·m (141 lb in)	7.5 N·m (66 lb in)	11 N·m (96 lb in)
M8	20 N·m (179 lb in)	27 N·m (240 lb in)	29 N·m (257 lb in)	39 N·m (343 lb in)	18 N·m (163 lb in)	27 N·m (240 lb in)
M10	40 N·m (30 lb ft)	54 N·m (40 lb ft)	57 N·m (42 lb ft)	77 N·m (56 lb ft)	37 N·m (27 lb ft)	53 N·m (39 lb ft)
M12	70 N·m (52 lb ft)	93 N·m (69 lb ft)	100 N·m (74 lb ft)	134 N·m (98 lb ft)	63 N·m (47 lb ft)	91 N·m (67 lb ft)
M16	174 N·m (128 lb ft)	231 N·m (171 lb ft)	248 N·m (183 lb ft)	331 N·m (244 lb ft)	158 N·m (116 lb ft)	226 N·m (167 lb ft)
M20	350 N·m (259 lb ft)	467 N·m (345 lb ft)	484 N·m (357 lb ft)	645 N·m (476 lb ft)	318 N·m (235 lb ft)	440 N·m (325 lb ft)
M24	607 N·m (447 lb ft)	809 N·m (597 lb ft)	838 N·m (618 lb ft)	1118 N·m (824 lb ft)	552 N·m (407 lb ft)	

IDENTIFICATION

Metric Hex head and carriage bolts, classes 5.6 and up

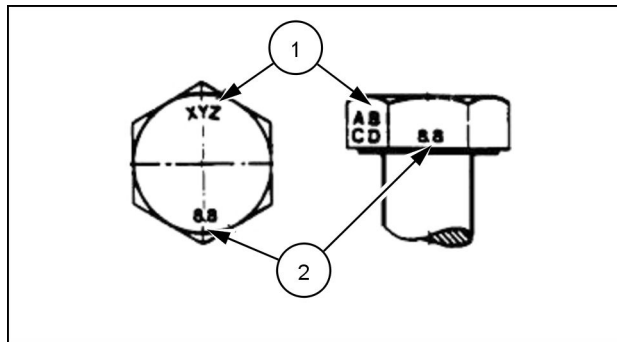

20083680 1

1. Manufacturer's Identification
2. Property Class

Metric Hex nuts and locknuts, classes 05 and up

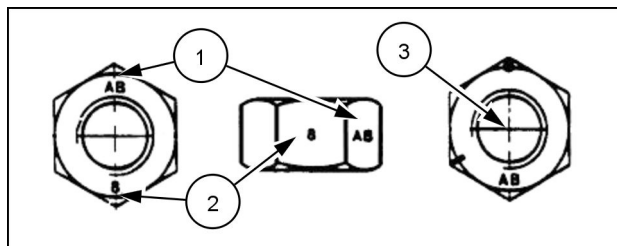

20083681 2

INTRODUCTION

Torque values for O-Ring Face Seals (ORFS) connections

SAE dash size	UN/UNF thread size	Inch tube OD (mm)	Metric tube OD (mm)	Hex size (mm) (Reference only)	* Swivel nut torque N·m (lb ft) ± 10 %	** Swivel nut torque N·m (lb ft) ± 10 %
4	9/16-18	6.35	6	17	27 (19.9)	27 (19.9)
5	5/8-18	7.94	8	19	34 (25.1)	34 (25.1)
6	11/16-16	9.52	10	22	44 (32.5)	44 (32.5)
8	13/16-16	12.7	12	24	65 (47.9)	65 (47.9)
10	1-14	15.88	16	30	100 (73.8)	100 (73.8)
12	1-3/16-12	19.05	20	36	150 (110.6)	131 (96.6)
14	1-5/16-12	22.23	22	41	163 (120.2)	131 (96.6)
16	1-7/16-12	25.4	25	41	210 (154.9) ***	131 (96.9)
20	1-11/16-12	31.75	30	50	280 (206.5) ***	178 (131.3)
24	2-12	38.1	38	60	375 (276.6) ***	210 (154.9)

* High/Medium-pressure applications > 50 bar (725 psi).

** Low-pressure applications < 50 bar (725 psi).

*** It is recommended to use a four-bolt flange connection instead of O-Ring Face Seals (ORFS) sizes "16" and up.

Torque values for 37 ° flare connections - Joint Industry Council (JIC)

SAE dash size	UN/UNF thread size	Metric tube OD (mm)	Inch tube OD (mm)	Swivel nut torque N·m (lb ft) ± 10 %
2	5/16-24	–	3.18	8.25 (6.1)
3	3/8-24	–	4.76	11.5 (8.5)
4	7/16-20	6	6.35	15.5 (11.4)
5	1/2-20	8	7.94	20 (14.8)
6	9/16-18	10	9.52	25 (18.4)
8	3/4-16	12	12.7	52 (38.4)
10	7/8-14	16	15.88	81 (59.7)
12	1-1/16-12	20	19.05	112 (82.6)
14	1-3/16-12	–	22.22	133 (98.1)
16	1-5/16-12	25	25.4	155 (114.3)
20	1-5/8-12	30/32	31.75	180 (132.8)
24	1-7/8-12	38	38.1	225 (166)
32	2-1/2-12	50	50.8	348 (256.7)

Torque values for 30 ° flare, 60 ° cone connections

Nominal size (mm)	British Standard Pipe Parallel (BSPP) thread size	Hex size (mm)	Swivel nut torque N·m (lb ft) ± 10 %
5, 6, 6.3	G 1/4	17	25 (18.4)
8, 9, 10	G 3/8	19	34 (25.1)
12, 12.5	G 1/2	22	64 (47.2)
15, 16, 19	G 3/4	30	132 (97.4)
25	G 1	36	196 (144.6)
31.5, 32	G 1-1/4	46	225 (166)
38	G 1-1/2	50	255 (188.1)
50, 51	G 2	65	316 (223.1)

INTRODUCTION

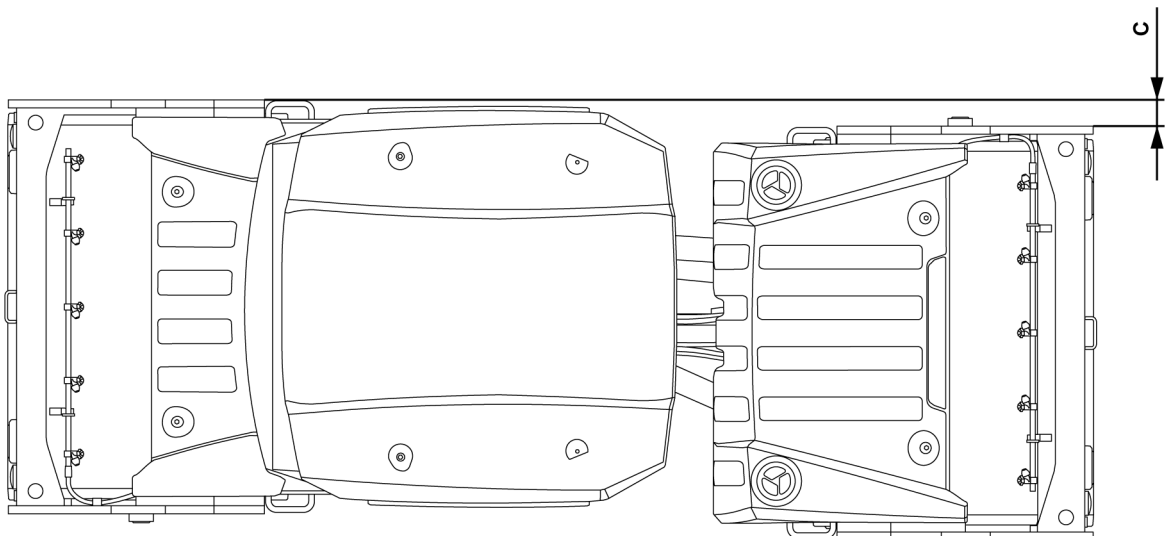
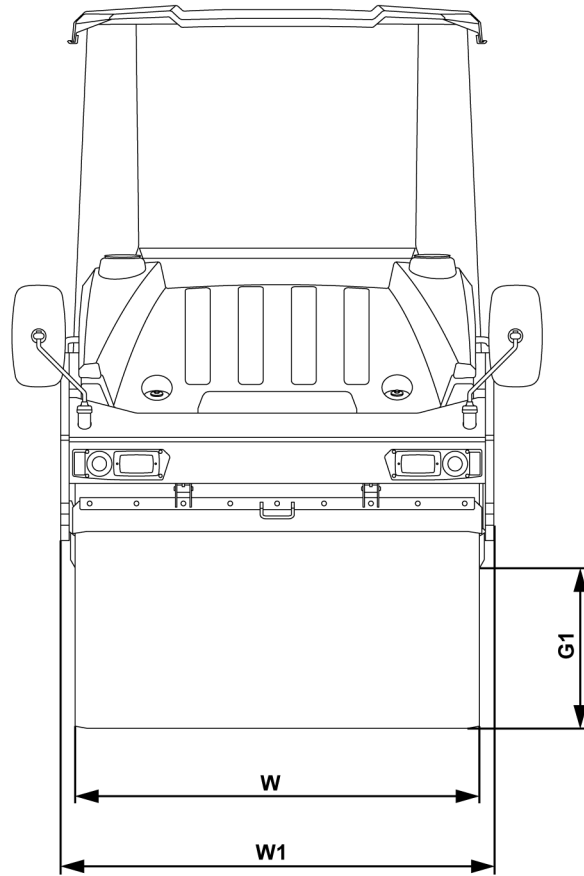

RAIL14COM0309HC 2

Contents

Engine - 10

Engine and crankcase - 001

TECHNICAL DATA

Engine

General specification (*)	3
---------------------------------	---

FUNCTIONAL DATA

Engine

Component identification (*)	4
------------------------------------	---

(*) See content for specific models

5. Remove the bolts, lock washers and washers (4) and brackets (5).

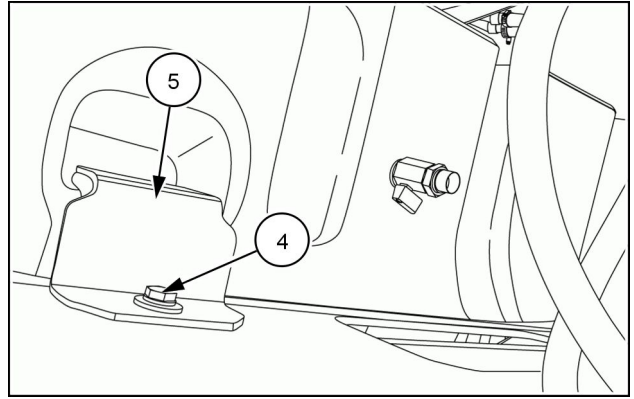

RAIL14COM0739AA 4

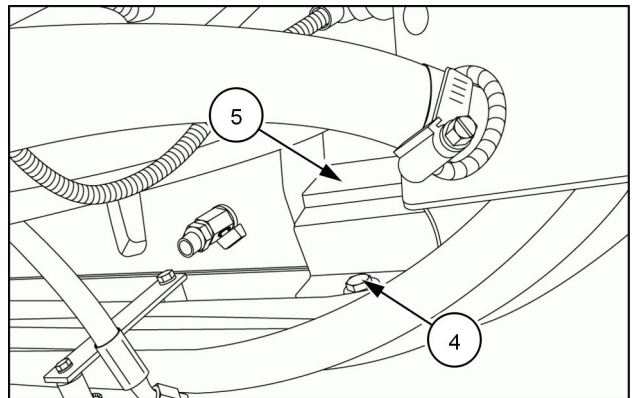

RAIL14COM0740AA 5

6. Remove the bolts and washers (6) and bushings, sleeves and shims (7).

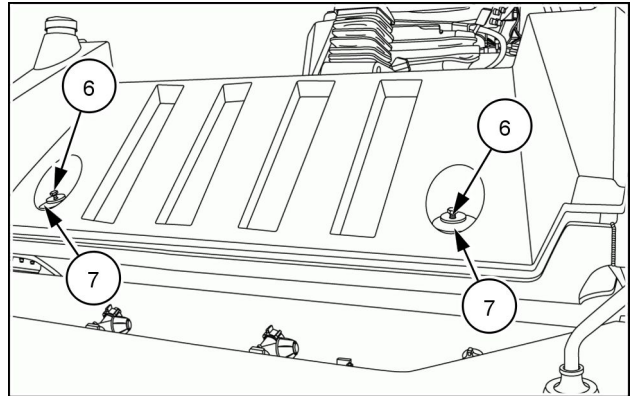

RAIL14COM0741AA 6

7. Remove the fuel tank (8).

NOTICE: Use suitable lifting equipment. Approx weight of the fuel tank: **40 kg (88 lb)**.

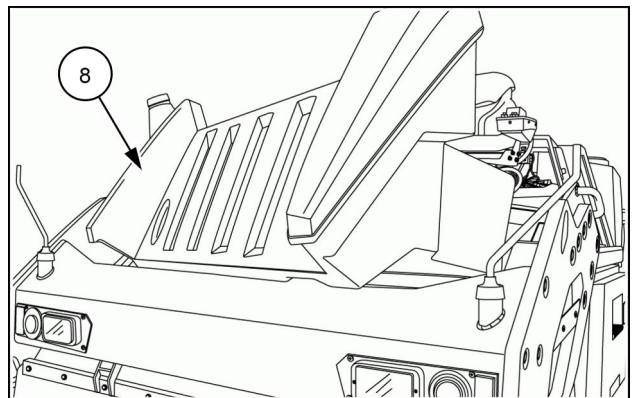

RAIL14COM0742AA 7

7. Disconnect the connector from the cooling fan solenoid valve (**Y4**).
8. Remove the hoses (**3**) and (**5**) from the solenoid valve.
9. Remove the hose (**4**) from the hydraulic motor.

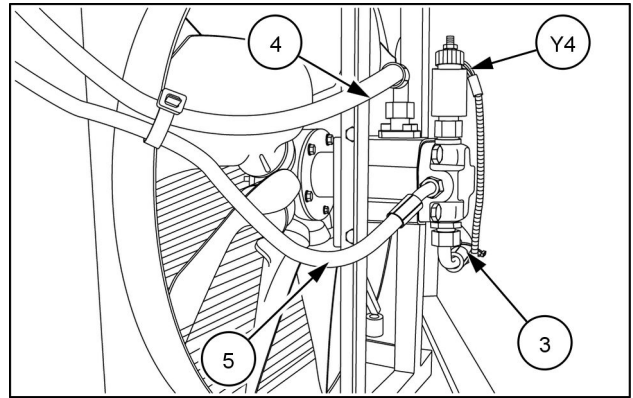

RAIL14COM0657AA 5

10. Remove the bolts (**1**) which secure the fan bracket (**2**) on the radiator (**3**).

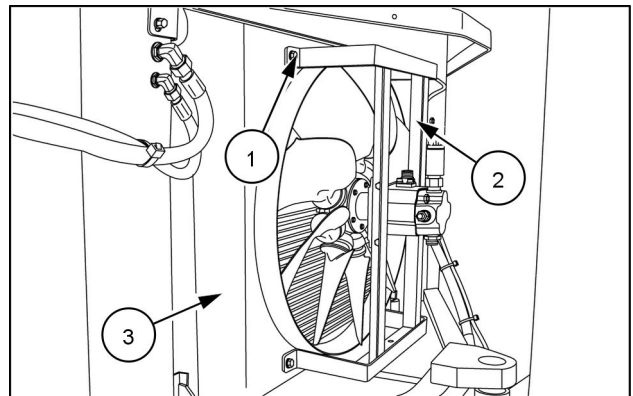

RAIL14COM0658AA 6

11. Remove the fan bracket and fan assembly (**A**).

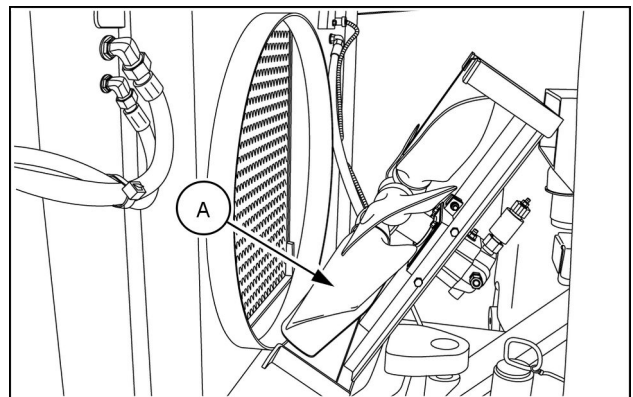

RAIL14COM0659AA 7

12. Remove the bolts (**1**) which secure the fan cover (**2**) on the frame.
13. Remove the fan cover (**9**).

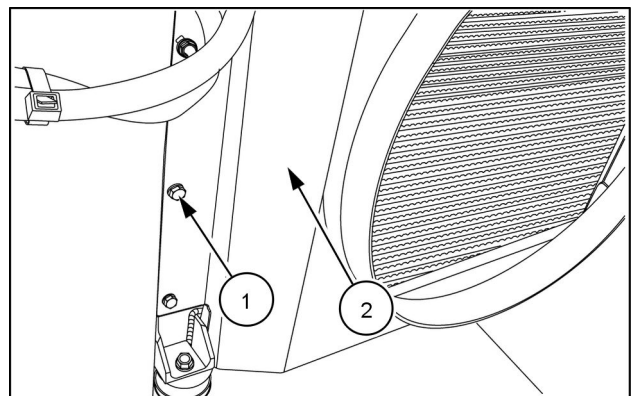

RAIL14COM0668AA 8

22. Install the radiator cover (1).

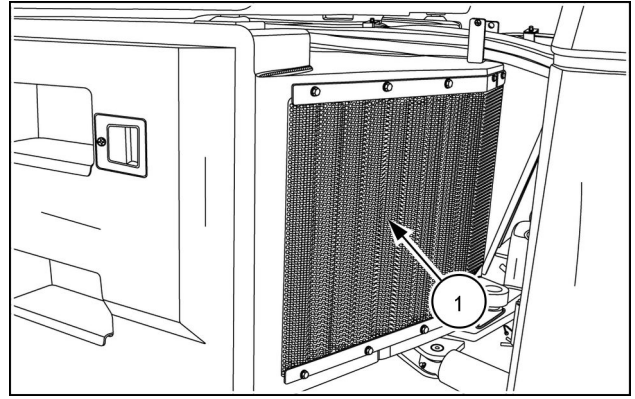

RAIL14COM0542AA 22

23. Refill the hydraulic system.
24. Refill the engine coolant.
25. Start the machine and check for serviceability and leaks.
26. Top off the hydraulic system and coolant if necessary.

Hydraulic systems - Hydraulic schema

DV209B

S. No	Description
1.	Travel pump
2.	Front vibration pump
3.	Rear vibration pump
4.	Steering pump
5.	Cooling pump
6.	Front drum travel motor (left-hand side)
7.	Rear travel hydraulic motor (right-hand side)
8.	Rear vibration motor
9.	Cooling fan motor
10.	Steering cylinder
11.	Crab cylinder
12.	Edge cutter cylinder (optional)
13.	Front vibration motor
14.	RTM control module
15.	Power steering unit
16.	RTM and flushing block
17.	Brake block
18.	Edge cutter and crab control block
19.	Edge cutter switch
20.	Oil filter
21.	Radiator
22.	Reservoir
23.	Filler port
24.	Oil level sensor
25.	Sight gage
26.	Temperature sensor
27.	Priority valve
28.	Non-return valve
29.	Non-return valve
30.	Non-return valve
31.	Ball valve
32.	Ball valve
33.	Filling quick coupler (not used)
34.	Quick coupler for measurements

Oil reservoir - Install

Double Drum DV

1. Place the reservoir (9) in its correct position in the engine compartment.

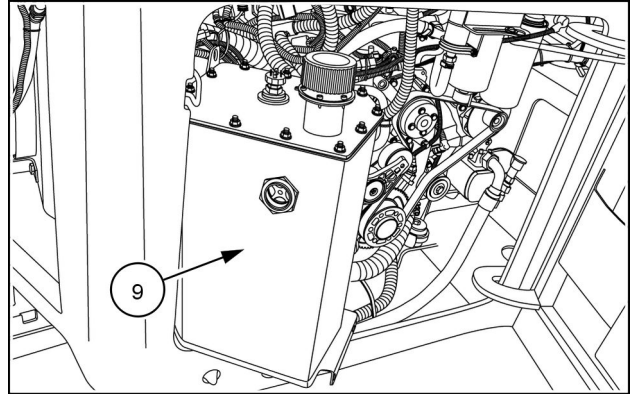

RAIL14COM0488AA 1

2. Secure the reservoir (9) in place with the bolts (8).

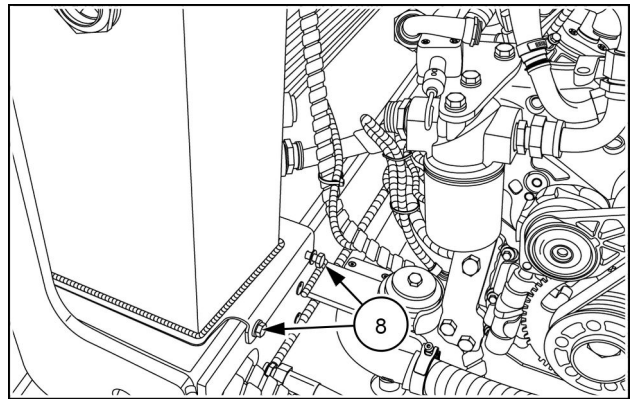

RAIL14COM0487AA 2

3. Install the bolts (6) and nut (7).

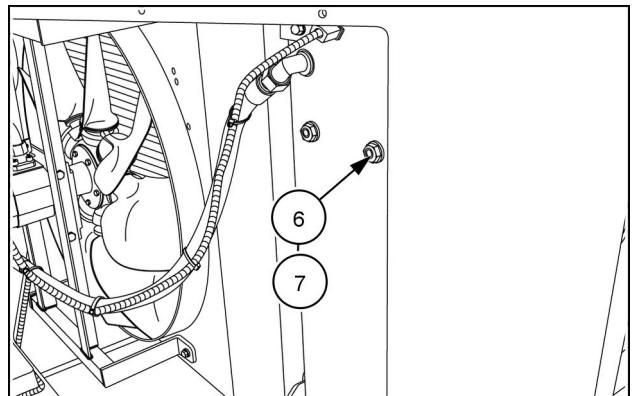

RAIL14COM0486AA 3

4. Apply LOCTITE® SI 598™ BLACK on the flanges of the dipstick pipe (4).

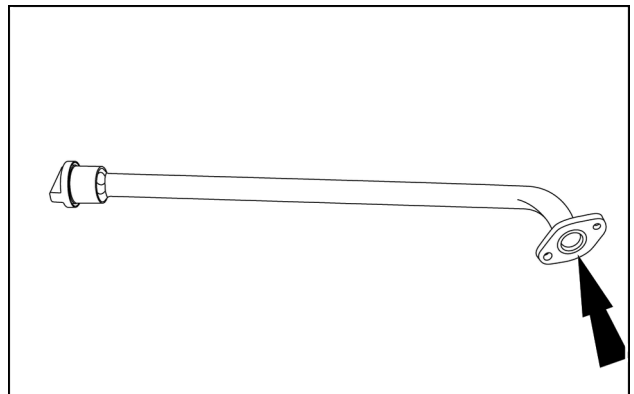

RAIL14COM0484AA 4

8. Make identification marks on the hoses and remove them from the travel control unit (4).

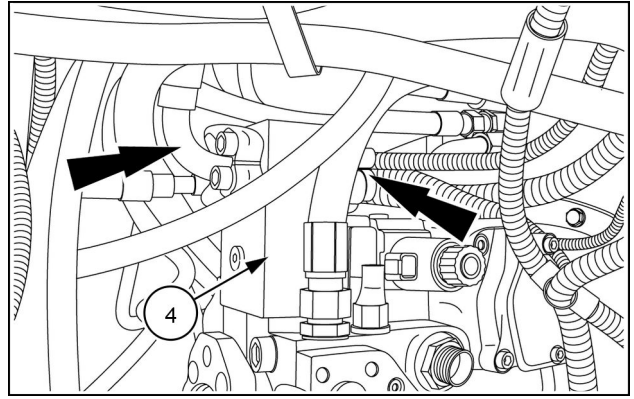

RAIL14COM0574AA 8

9. Support the pump (3) on a suitable lifting device with adequate capacity.

NOTICE: Approximate weight of the pump: **110 kg (243 lb)**.

10. Remove the bolts (5).

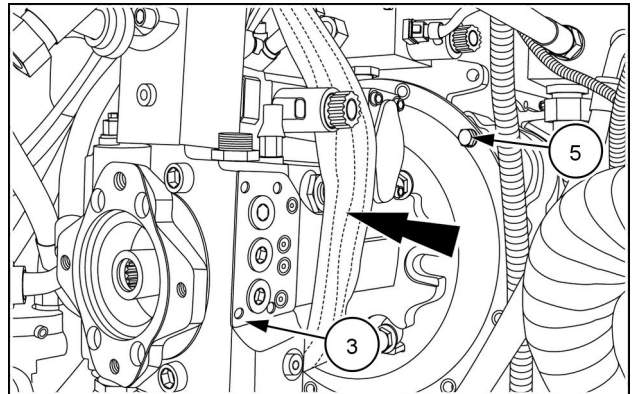

RAIL14COM0622AA 9

11. Carefully remove the pump from the engine compartment.

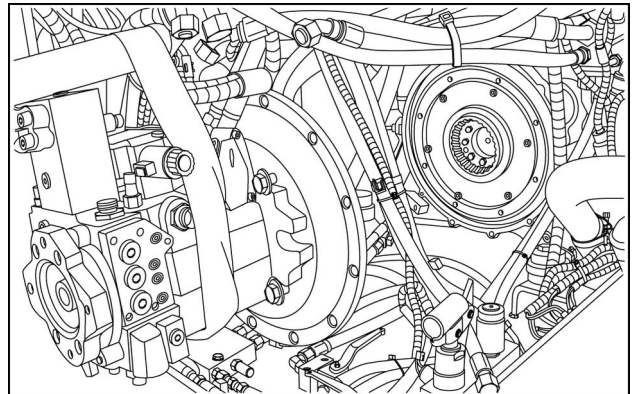

RAIL14COM0575AA 10

12. Remove the bolts (6).
13. Remove the flange (7).

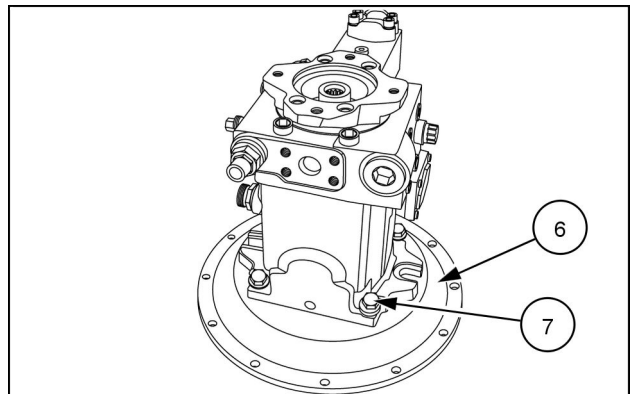

RAIL14COM0623AA 11

Travel reduction gear - Install

Double Drum DV

NOTE: The below procedure shows the installation of the rear travel reduction gearbox (located on the right-hand side of the drum). The procedure is the same to install the front travel reduction gearbox (located on the left-hand side of the drum).

1. Lay the reduction gearbox (1) on a stable surface with the drive motor surface facing down.
2. Install the carrier (2) over the reduction gearbox (1) with the vibration isolator surface (4) facing up.
3. Secure the carrier to the reduction gearbox with the bolts originally removed.
4. Turn the carrier and reduction gearbox over and place on a stable surface.

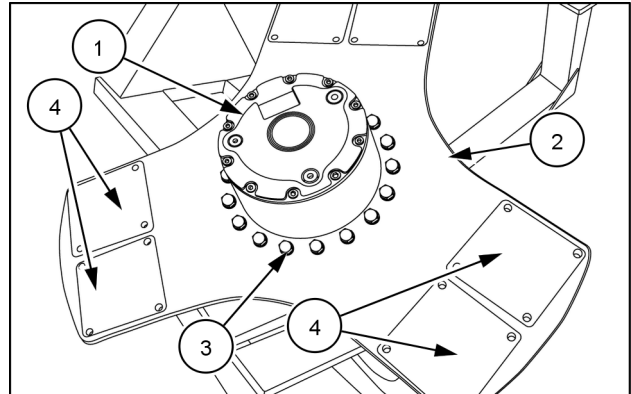

5. Install the travel motor on the reduction gearbox with the bolts originally removed.

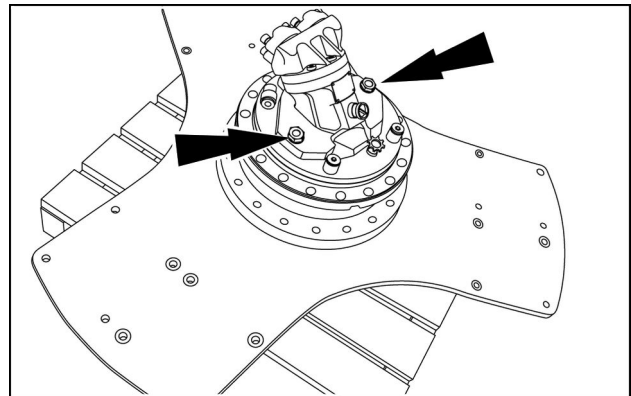

6. Install the lifting tool (T) onto the reduction gearbox and bolt in place.
7. Lift the carrier assembly back onto the unit with a suitable lifting device of adequate capacity.

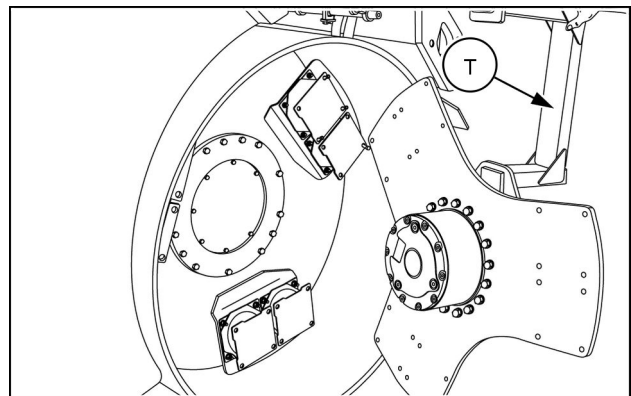

Filter

Filter element

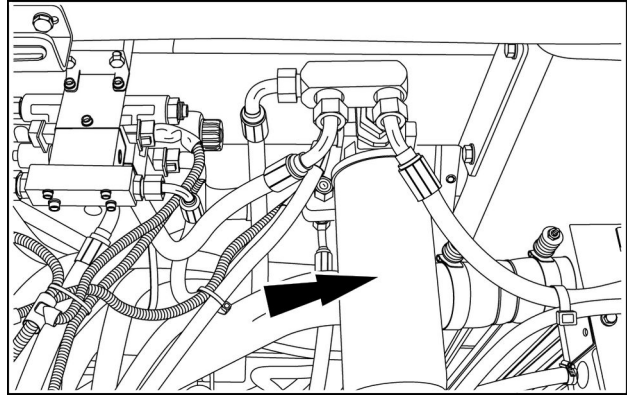

RAIL14COM0681AA 4

6. Adjust the gap between the fan cover and fan wings in a horizontal direction using bolts (7).

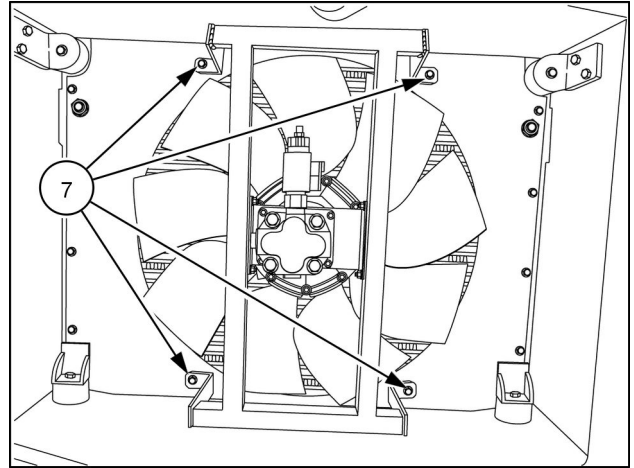

RAIL15COM0322AA 12

7. Adjust the gap between the fan cover and fan wings in a vertical direction using the bolts that mount the fan motor (11) and the fan bracket (8).

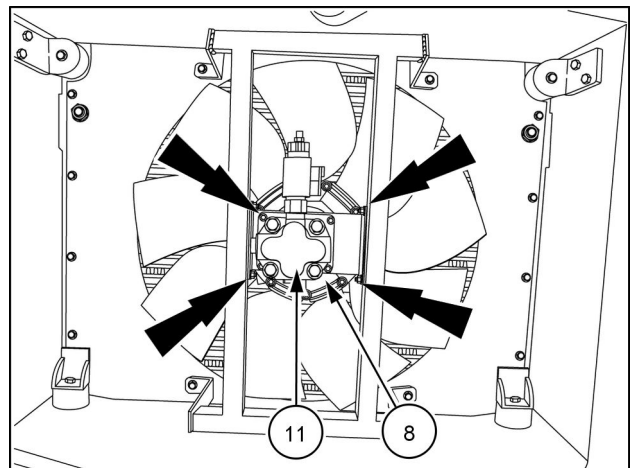

RAIL15COM0322AA 13

8. Install the hoses (4), (5) and (6) on the hydraulic motor.
9. Connect the valve connector (3).

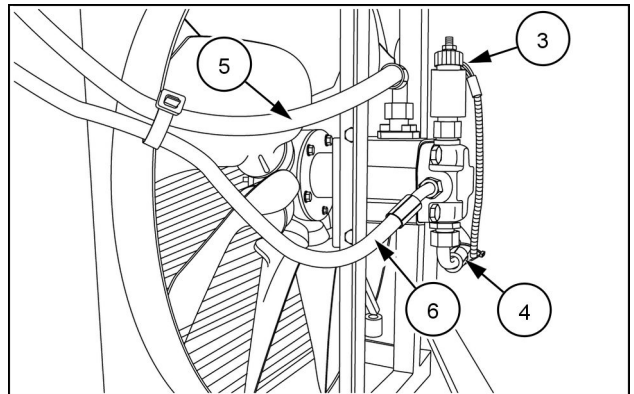

RAIL14COM0657AA 14

10. Install the cover (2).

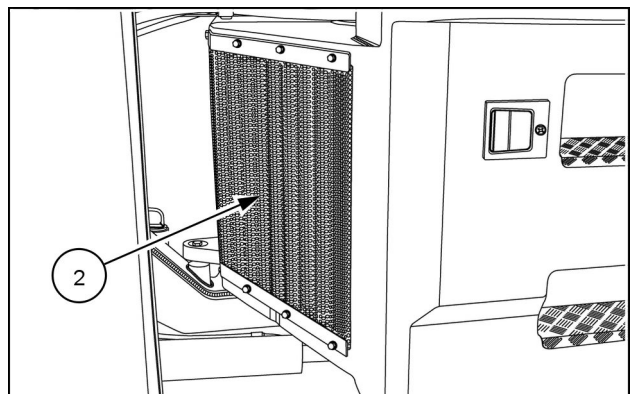

RAIL14COM0485AA 15

4. Install the hoses (2), (3), (4) and (5) on the pump (1).

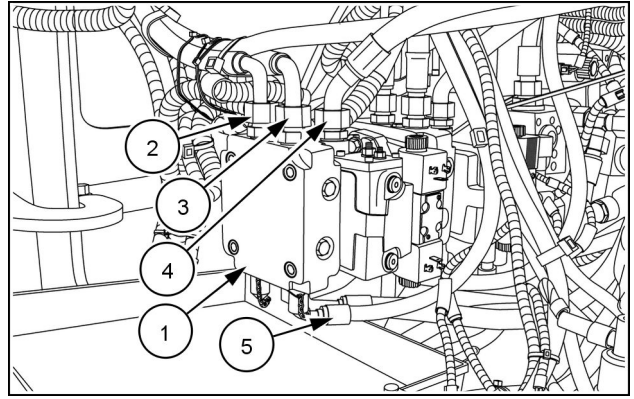

RAIL14COM0586AA 4

5. Connect the connector from the solenoids Y7 and Y8.

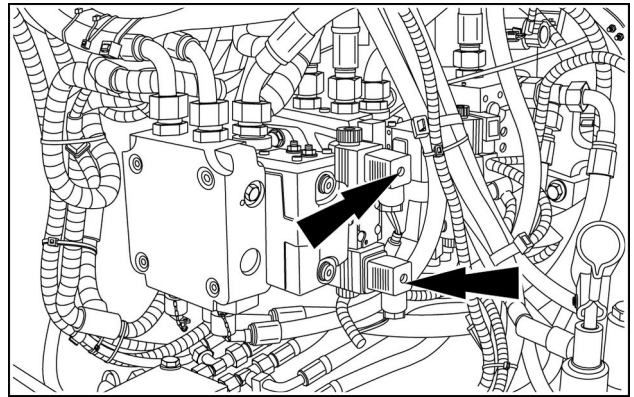

RAIL14COM0585AA 5

6. Install the drain plug and fill the system.
7. Start the machine and check for serviceability and leaks.
8. Top-up the hydraulic system if necessary.

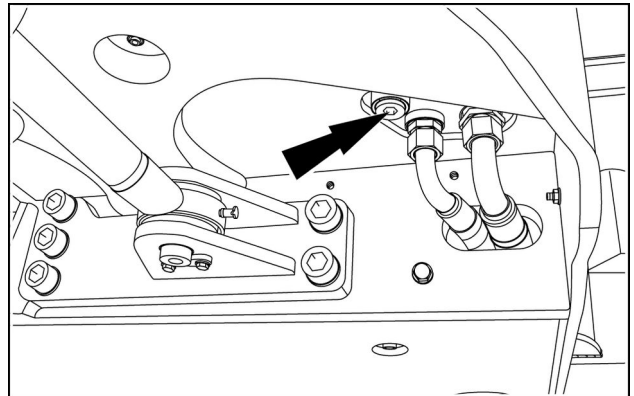

RAIL14COM0449AA 6



PRINTED IN U.S.A.

© 2016 CNH Industrial America LLC.

All rights reserved. No part of the text or illustrations of this publication may be reproduced.

CASE CONSTRUCTION policy is one of continuous improvement and the right to change prices, specification or equipment at any time without notices is reserved.

All data given in this publication is subject to production variations. Dimensions and weight are approximate only and the illustrations do not necessarily show products in standard condition. For exact information about any particular product, please consult your CASE CONSTRUCTION Dealer.

9. Lower the bracket on suitable supports.

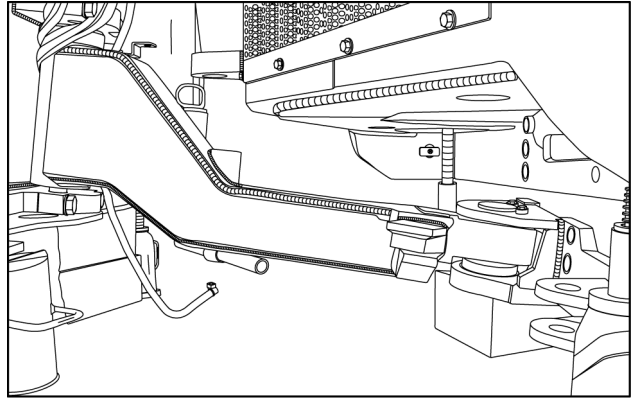

RAIL14COM0506AA 7

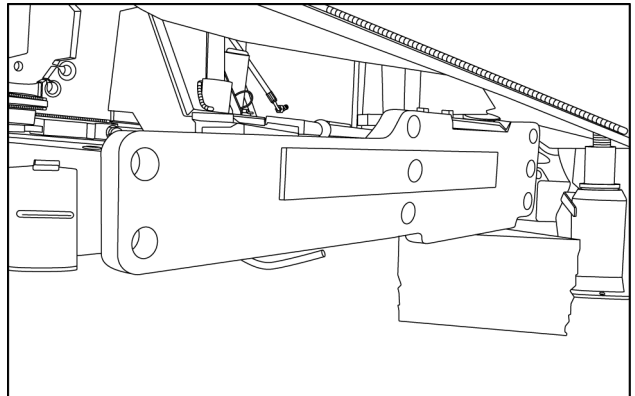

RAIL14COM0507AA 8

10. Remove the hose clamps (6).

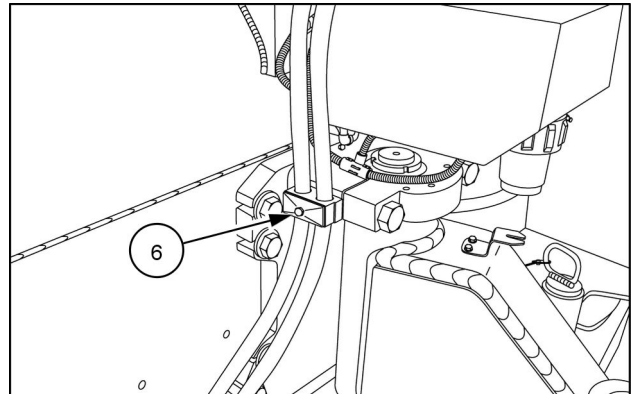

RAIL14COM0500AA 9

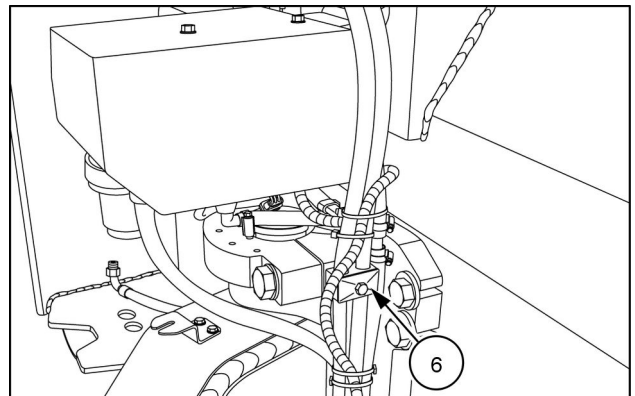

RAIL14COM0501AA 10

4. Grease with **CASE AKCELA MOLY GREASE** and then install the bearing (9) on the bearing races.

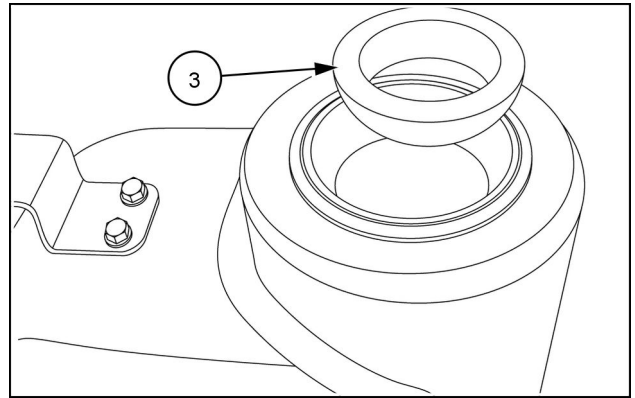

RAIL14COM0533AA 4

5. Insert the pin (3) on the link arm (6) and secure the other end of the pin with the bushing (8).

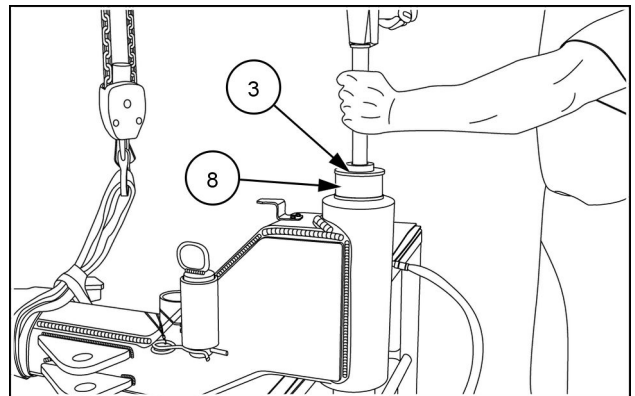

RAIL14COM0531AA 5

6. Install the pre-assembled link arm (6) on the bracket (7) with the yokes (5) and bolts (4).

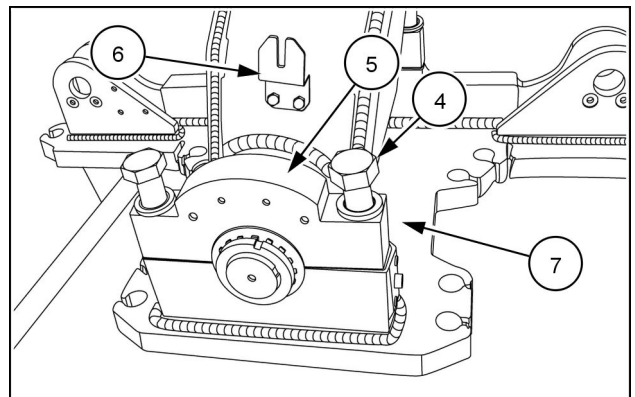

RAIL14COM0529AA 6

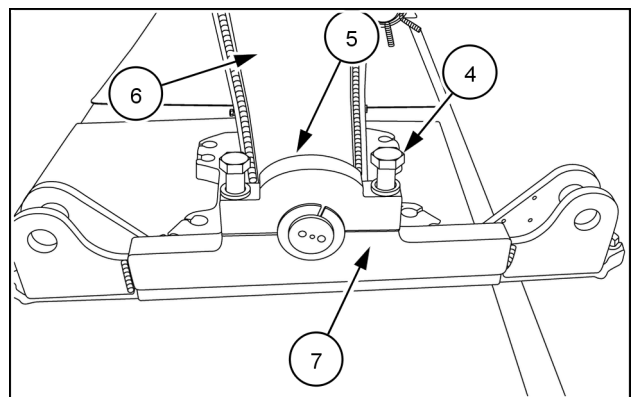

RAIL14COM0530AA 7

9. Remove the clamps (10) and hardware which secures the hoses and cables on the arm.

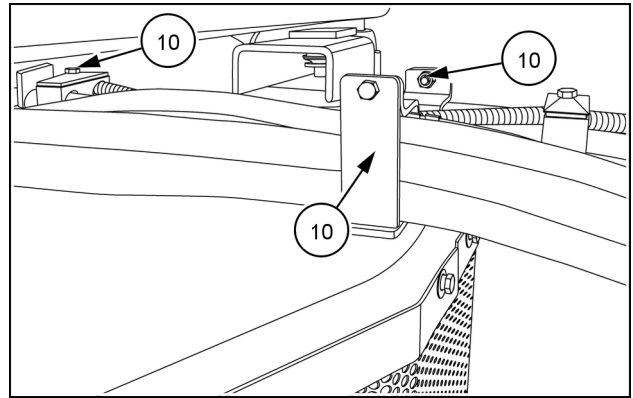

RAIL14COM0551AA 8

10. Drain the coolant in a suitable container with adequate capacity.

NOTE: Approximate drain volume: 23 L (6 US gal).

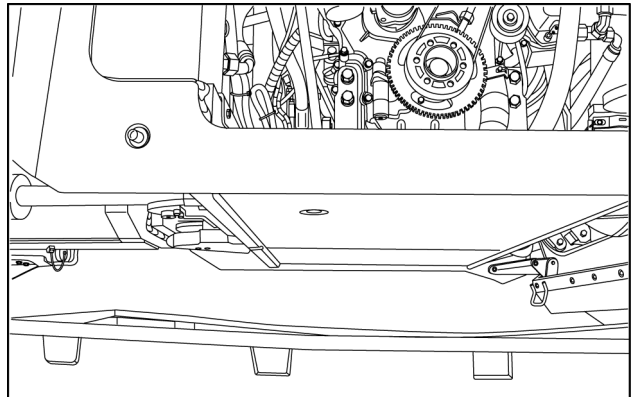

RAIL14COM0514AA 9

11. Remove the radiator covers.

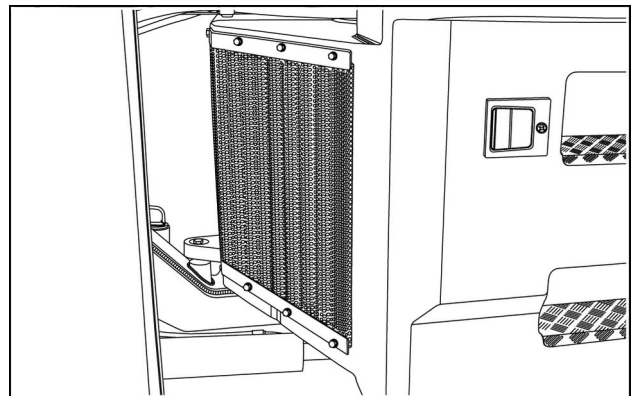

RAIL14COM0485AA 10

12. Remove the two hose clamps (1) and then remove the hose (2).

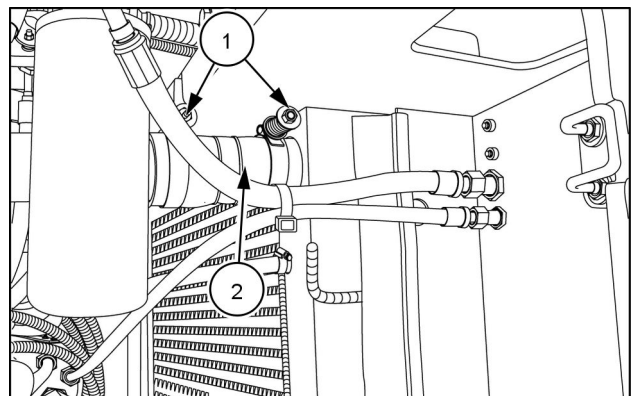

RAIL14COM0543AA 11

Compaction - sprinkling/sprayer system - Install - Water tank

Double Drum DV

1. Apply **LOCTITE® 5331** on the contact surfaces of the plugs, necks, water level sensor and sight gage and the water tank.
2. Install the plugs, necks, water level sensor, sight gage and filler caps on the new tank.
3. Lift the tank with a suitable lifting equipment of adequate capacity and place it in its correct position on the frame.

NOTICE: Approximate tank weight: **80 kg (176 lb)**

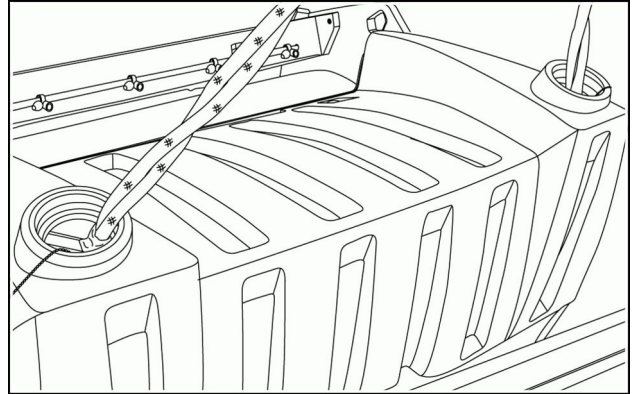

RAIL14COM0759AA 1

4. Secure the tank on the frame with the plates (12), washers (11) and bolts (10).

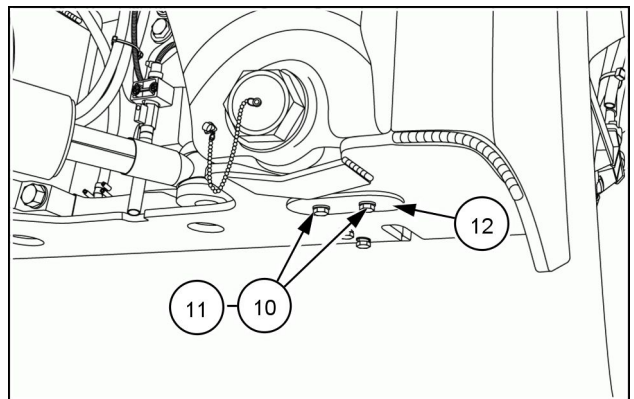

RAIL14COM0756AA 2

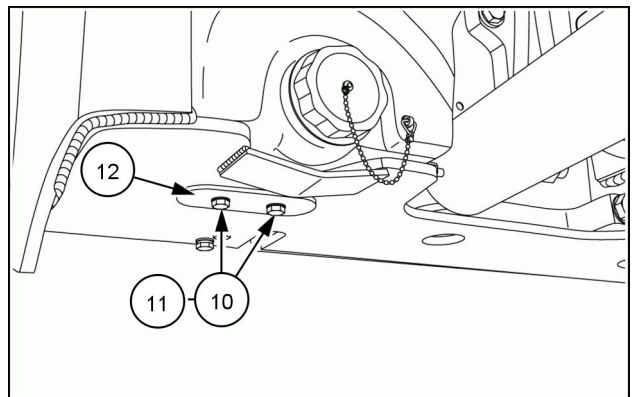

RAIL14COM0757AA 3

5. Secure the tank with the sleeve (9), bushing (8), washers (7), lock washers (6) and bolts (5).

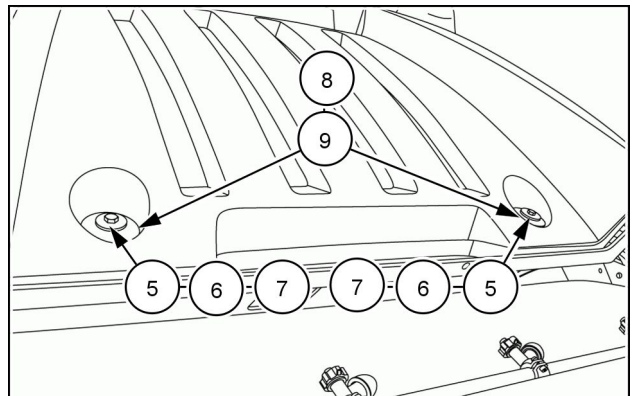

RAIL14COM0755AA 4

Index

Frames and ballasting - 39

Vibratory roller - 500

Compaction - sprinkling/sprayer system - Install - Sprinkler pumps (*)	5
Compaction - sprinkling/sprayer system - Install - Water tank (*)	10
Compaction - sprinkling/sprayer system - Remove - Sprinkler pumps (*)	3
Compaction - sprinkling/sprayer system - Remove - Water tank (*)	7
Damping system - vibration isolators - Install (*)	17
Damping system - vibration isolators - Remove (*)	13

(*) See content for specific models

CLICK HERE TO **DOWNLOAD** THE COMPLETE MANUAL

- Thank you very much for reading the preview of the manual.
- You can download the complete manual from: www.heydownloads.com by clicking the link below



- Please note: If there is no response to CLICKING the link, please download this PDF first and then click on it.

CLICK HERE TO **DOWNLOAD** THE COMPLETE MANUAL

Control unit

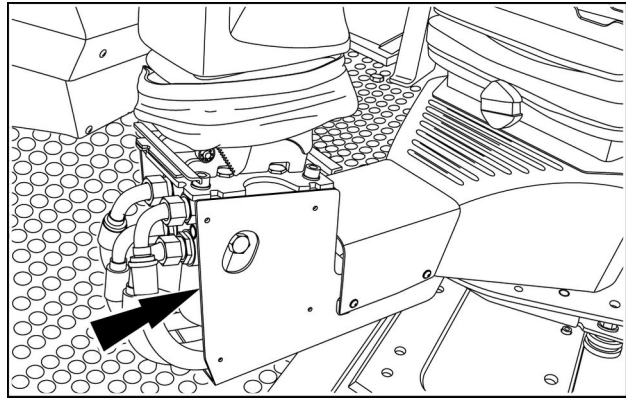

RAIL14COM0454AA 5

Technical data of the manufacturer

Control unit	
Steering pump delivery	16 cm³/rev (1 in³/rev)
Working pressure	175 bar (2538 psi)
Weight	5 kg (11 lb)

7. Remove the steering column (**9**).

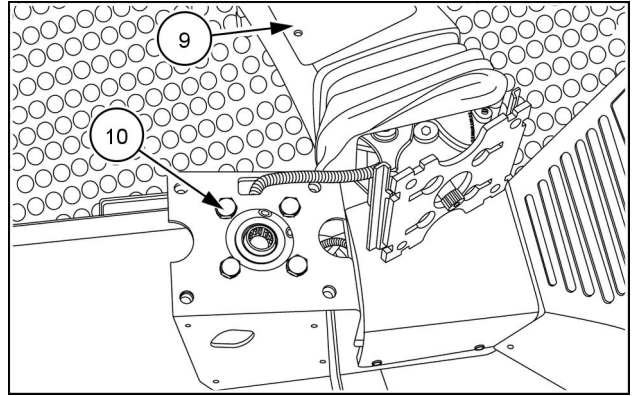

RAIL14COM0477AA 4

8. Remove the bolts (**10**) and washers.
9. Remove the steering control unit.

Cylinders - Install - Crab cylinder

Double Drum DV

1. Position the cylinder **(1)** in its correct position.
2. Apply grease on the surfaces of the cylinder end pin **(5)**.
3. Secure the cylinder end of the cylinder in place with the pin **(5)**, rings and shims removed earlier.
4. Apply grease on the surfaces of the rod end pin **(4)**.
5. Secure the cylinder end of the cylinder in place with the pin **(4)**, rings and shims removed earlier.

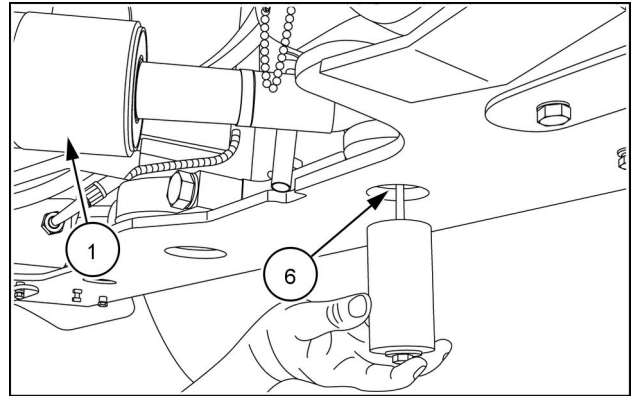

RAIL14COM0467AA 1

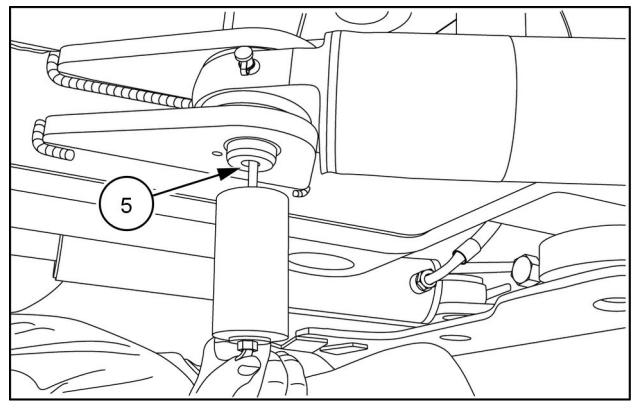

RAIL14COM0466AA 2

6. Install the lock plates with the attaching hardware **(2)**.

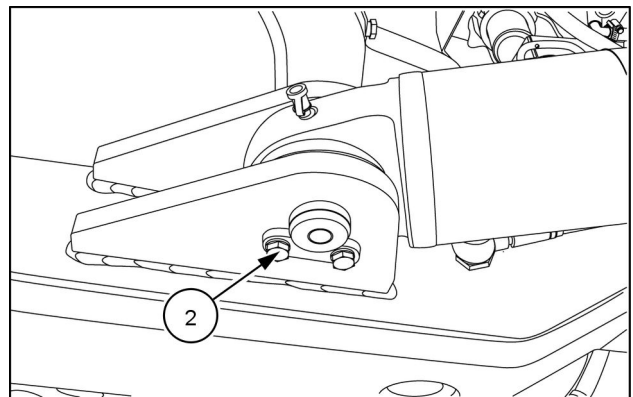

RAIL14COM0463AA 3

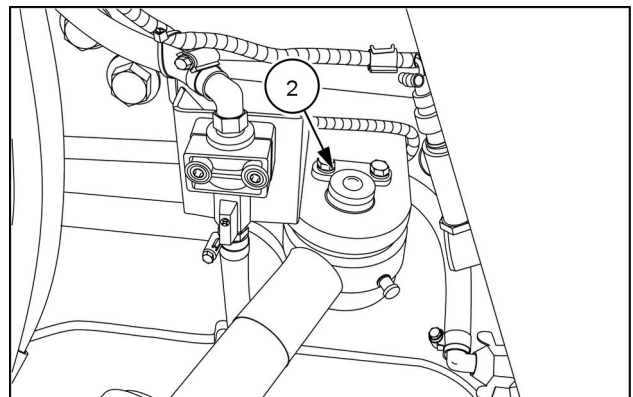

RAIL14COM0464AA 4

Index

Steering - 41

Cylinders - 216

Cylinders - Assemble (*)	18
Cylinders - Disassemble (*)	16
Cylinders - Exploded view (*)	3
Cylinders - Install - Crab cylinder (*)	10
Cylinders - Install - Steering cylinder (*)	14
Cylinders - Remove - Crab cylinder (*)	8
Cylinders - Remove - Steering cylinder (*)	12
Cylinders - Sectional view - Crab cylinder (*)	7
Cylinders - Sectional view - Steering cylinder (*)	6

(*) See content for specific models

Wheels - Compaction drums

S. No	Description
1.	Drive flange
2.	Bolt
3.	Lock nut
4.	Lock washer
5.	Bearing
6.	Collar
7.	Gasket
8.	Sealing ring
9.	Bolt
10.	Washer
11.	Drive plate
12.	Carrier assembly
13.	Nut
14.	Vibration isolator
15.	Washer
16.	Cap screw
17.	Clutch
18.	Ring
19.	Bolt
20.	Pulse sensor
21.	Motor housing
22.	Grease fitting
23.	Plug

11. Connect the connectors X26.

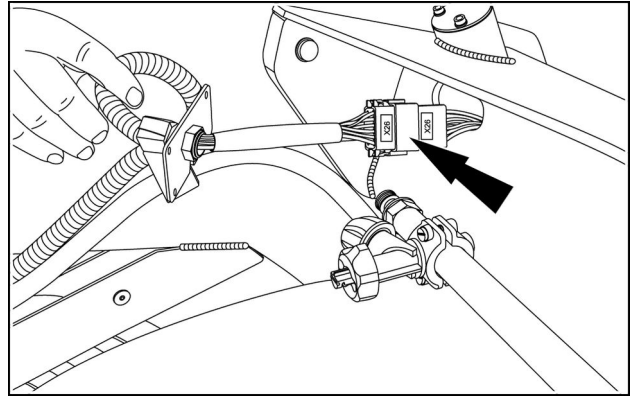

RAIL14COM0599AA 8

12. Install the cover (15) on the cross member with the bolts removed earlier.
13. Install the hose (14) on the sprinkler.
14. Secure the hose (14) and harness on the side bracket (25) with the clamps (13) and attaching hardware removed earlier.

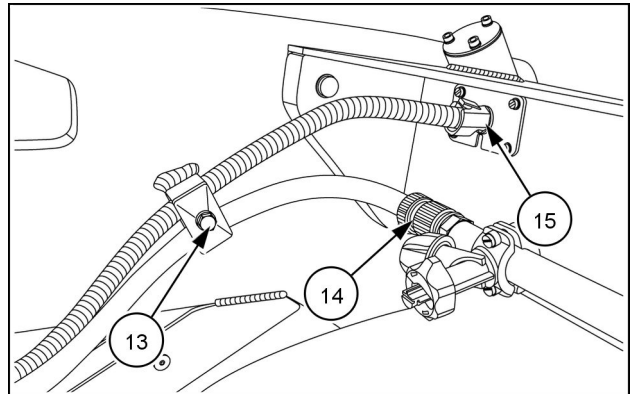

RAIL14COM0598AA 9

Travel motor side

15. Lift the side bracket (9) with a lifting device of adequate capacity and place in its correct position on the travel reduction gearbox.

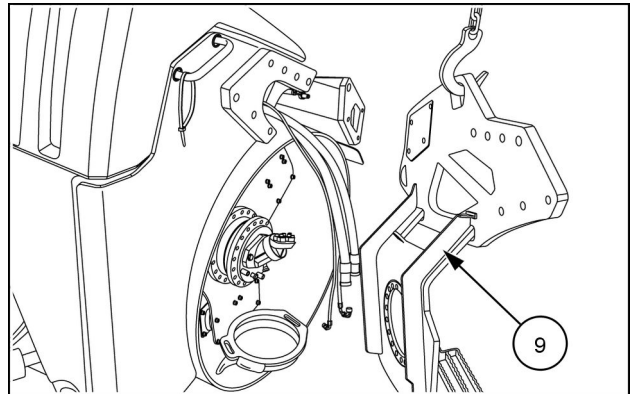

RAIL14COM0558AA 10

16. Install the side bracket (9) on the travel reduction gearbox with the bolts (12) removed earlier.

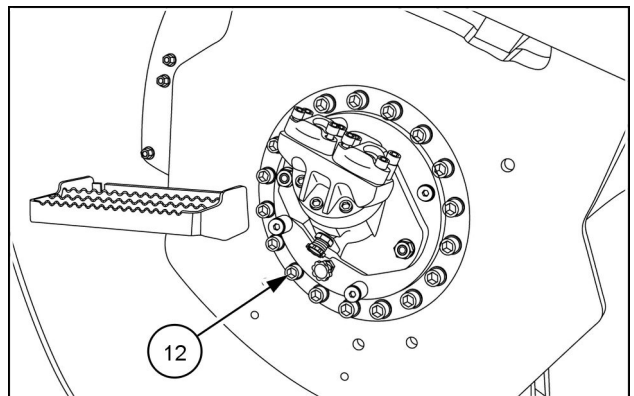

RAIL14COM0569AA 11

Bearings

Travel motor side

8. Install the bearing (25) on the cover assembly.

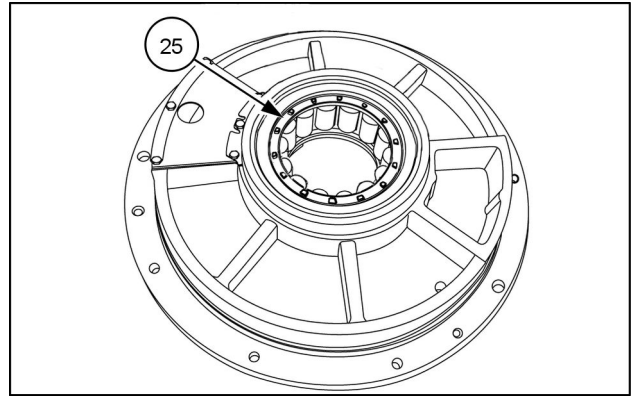

RAIL16COM0124AA 4

9. Secure the bearing (25) with the snap ring (22).

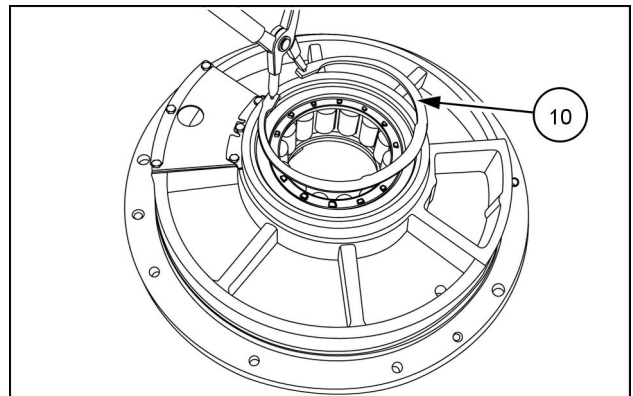

RAIL14COM0615AA 5

10. Apply Red RTV Silicone sealant on the contact surfaces of the cover (24).

11. Install the cover (24) with the bolts (23).

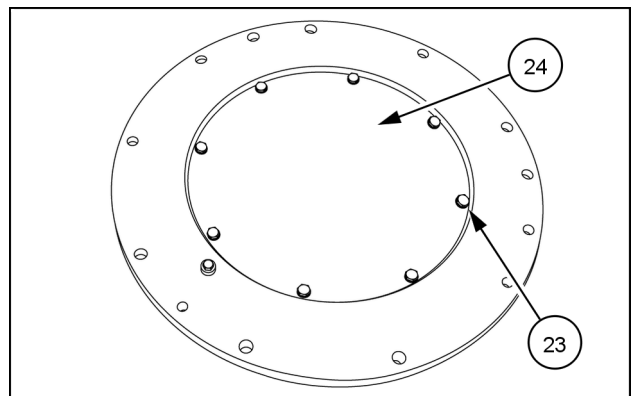

RAIL14COM0634AA 6

12. Lift the bearing cover assembly (19) with suitable lifting lugs (20) and lifting device and place in its correct position on the drum.

NOTICE: Make sure that the O-ring (21) is installed.

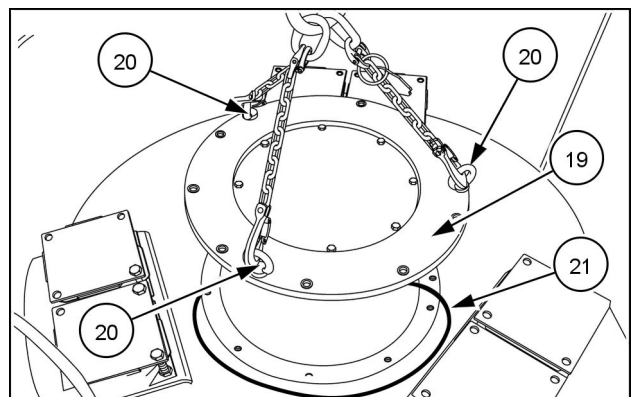

RAIL14COM0633AA 7

Compaction front drum bearings and carriers - Assemble

Double Drum DV

1. Heat the bearing cup (1) for the damper plate to **100 °C (212 °F)**.
2. Press the bearing cup (1) into the damper plate down to the shoulder.

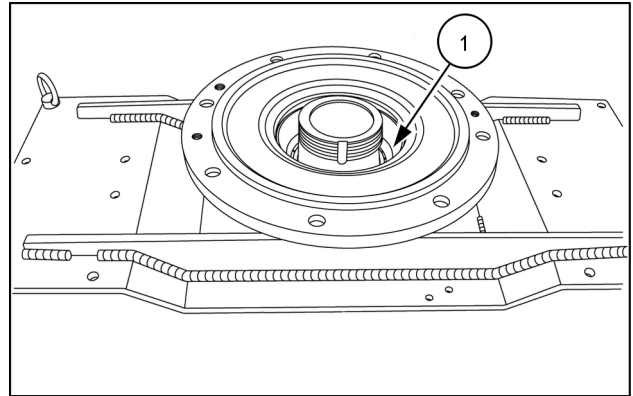

RAIL16COM0128AA 1

3. Grease the bearing cup and cone (24).
4. Install the bearing cone (24) onto the damper plate.

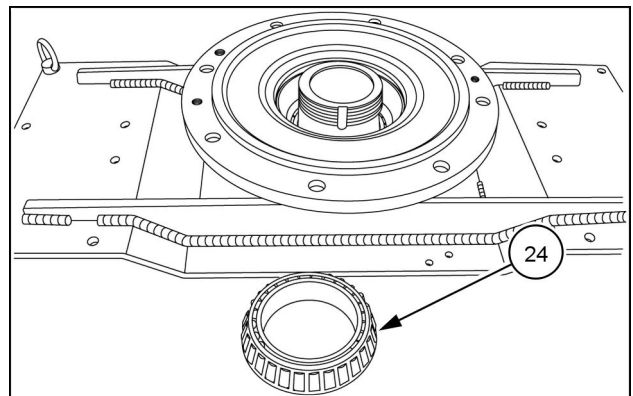

RAIL14COM0648AA 2

5. Install the lock washer and nut (23) onto the damper plate.
6. Tighten the nut to **550 - 650 N·m (406 - 480 lb ft)**. Loosen the nut and retighten to same torque.

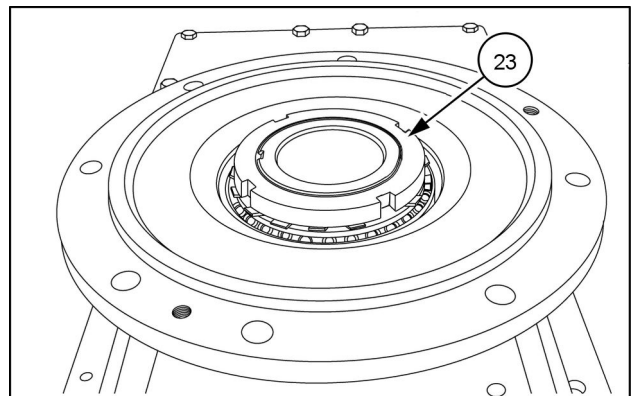

RAIL16COM0127AA 3

7. Lock the nut with a tab on the lockwasher.

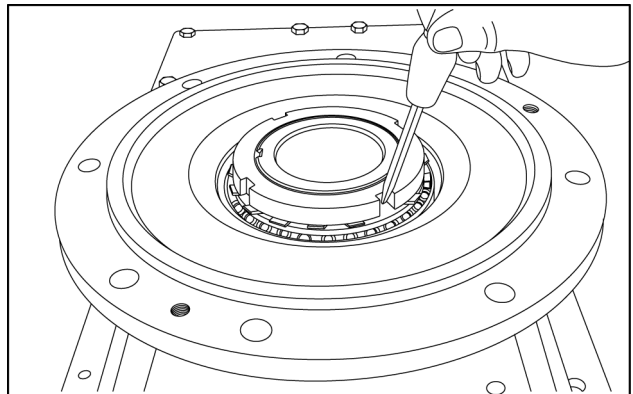

RAIL14COM0645AA 4

Contents

Cab climate control - 50

Heating - 100

SERVICE

Heater core	
Remove (*)	3
Install (*)	5
Heater control valve	
Remove (*)	7
Install (*)	8

(*) See content for specific models

Contents

Electrical systems - 55

[55.050] Heating, Ventilation, and Air-Conditioning (HVAC) control system.....	55.1
[55.100] Harnesses and connectors.....	55.2
[55.301] Alternator.....	55.3
[55.302] Battery.....	55.4
[55.408] Warning indicators, alarms, and instruments	55.5
[55.512] Cab controls.....	55.6

Contents

Electrical systems - 55

Harnesses and connectors - 100

FUNCTIONAL DATA

Harnesses and connectors

Overview - Best practice (*)	3
------------------------------------	---

Wiring harnesses

Electrical schematic sheet 02 - Starting, charging (*)	28
Electrical schematic sheet 03 - Engine (*)	30
Electrical schematic sheet 04 - Engine (*)	32
Electrical schematic sheet 05 - CAN network (*)	34
Electrical schematic sheet 06 - Electro hydraulic (*)	36
Electrical schematic sheet 07 - Electro hydraulic (*)	38
Electrical schematic sheet 08 - Electro hydraulic (*)	40
Electrical schematic sheet 09 - Electro hydraulic (*)	42
Electrical schematic sheet 10 - Electro hydraulic (*)	44
Electrical schematic sheet 11 - Driver Gessmann (*)	46
Electrical schematic sheet 12 - Driver Gessmann (*)	48
Electrical schematic sheet 13 - Lighting system (*)	50
Electrical schematic sheet 14 - Lighting system (*)	52
Electrical schematic sheet 15 - Lighting system (*)	54
Electrical schematic sheet 16 - Lighting system (*)	56
Electrical schematic sheet 17 - Lighting system (*)	58
Electrical schematic sheet 18 - Cab (*)	60
Electrical schematic sheet 19 - Cab (*)	62
Electrical schematic sheet 20 - Grounding system (*)	64
Electrical schematic sheet 21 - Grounding system (*)	66

Fuse and relay box

Identification (*)	69
--------------------------	----

(*) See content for specific models

Sealed and unsealed connectors

6. Use the appropriate tools to crimp the barrels. Follow these precautions while crimping:
 - A. Do not bend or crack the terminal.
 - B. Do not cut the wire strands with the barrel.
 - C. Verify that all wire strands are contained inside the core barrel.
 - D. Wires must not fall out of the barrels once they have been crimped.

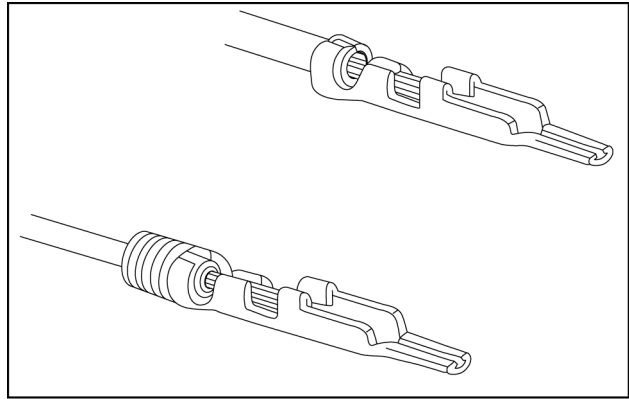

RAIL14SSL0614AA 27

7. Solder all hand-crimped terminals.
8. Check circuit for electrical continuity.

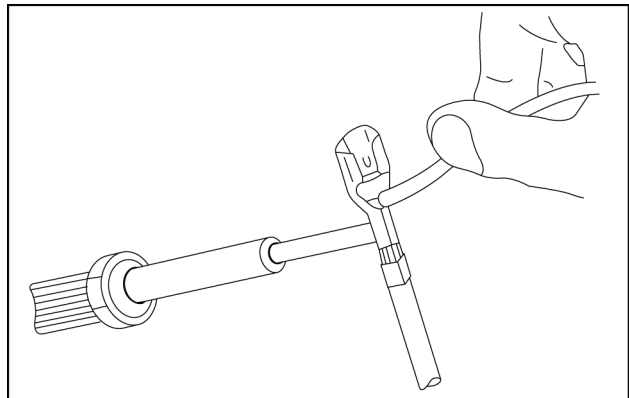

RAIL14SSL0615AA 28

Installing terminals in the connectors

NOTICE: *Installing the terminals do not require any special tools. Do not use excessive force to insert a terminal.*

1. Orient the terminal to its proper relationship with the connector body.
2. Insert the terminal into the correct connector cavity.
3. Push until the terminal “clicks” in place.
4. Gently pull the wire back to ensure the proper seating of the terminal. Verify that the terminal will not back out from the connector.

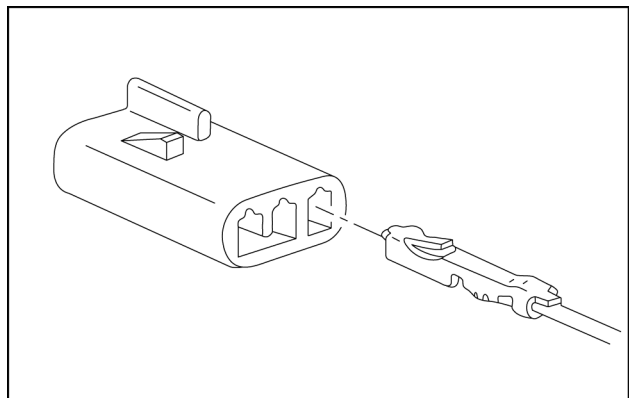

RAIL14SSL0616AA 29

Wires are locked in place with a wire lock or a Terminal Position Assurance (TPA) lock.

Wire locks or TPA locks are added in the connector to avoid damage to the wires as the exposed/loose wires are more prone to damage.

Wire locks and TPA locks vary in size and shape, depending on the type of connector being used.

Some connectors may not have wire or TPA locks.

NOTE: *Image shows connector without wire lock.*

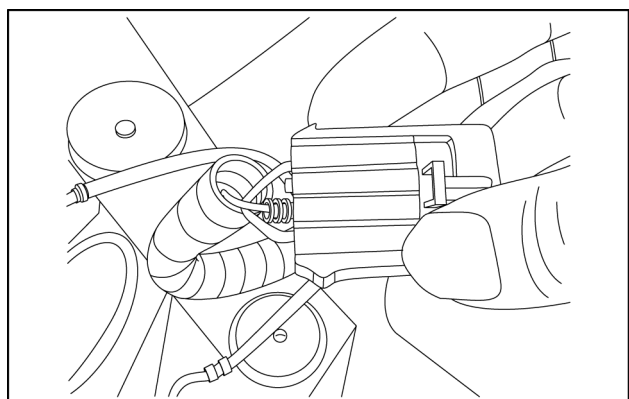

RAIL14SSL0617AA 30

4. Heat the splice clip with a soldering iron and apply solder to the splice clip.
5. Do not use too much solder. Too much solder might lead to wicking and makes the wire brittle, resulting in wire damage.
6. Check the continuity of the spliced wires.
7. Cover the splice with splice tape or heat shrink tubes.

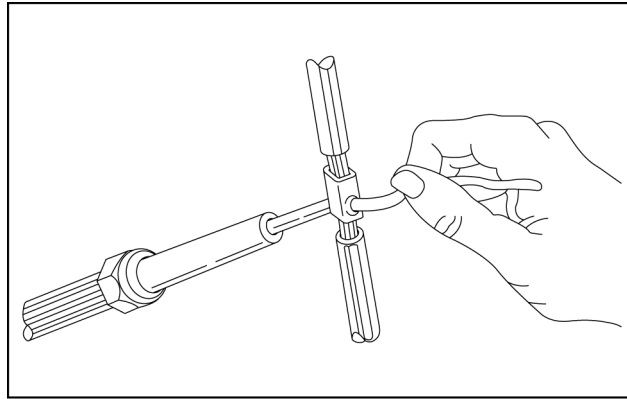

RAIL14SSL0646AA 59

Harness routing guidelines

Proper harness routing must be performed to ensure the electrical system reliability. Improper routing of the harness may lead to various electrical system malfunctions.

When repairing or replacing wire harnesses, verify that the harnesses are routed in their original position. Observe the following safety precautions while routing the harness.

Location

Verify that the harness:

- Should not come in contact with any moving parts.
- Should be placed at least **125 mm (5 in)** away from sources of radiant heat
- Should be away from any potentially damaging surfaces, such as sharp or abrasive objects, sheet metal holes, sharp metal flanges, etc.
- Should be placed at least **75 mm (3 in)** away from battery vents

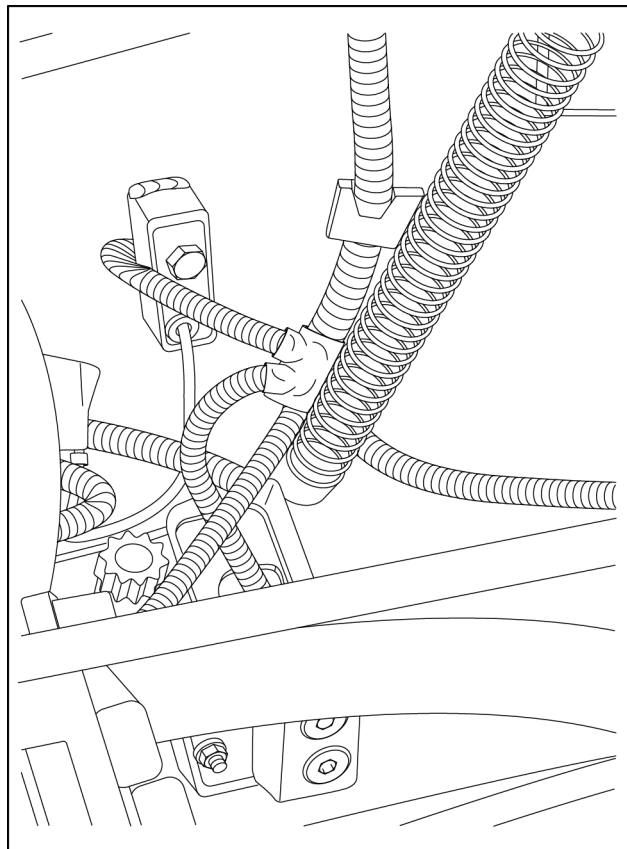

RAIL14SSL0647BA 60

Wiring harnesses - Electrical schematic sheet 04 - Engine

DV209B	
--------	--

Wiring harnesses - Electrical schematic sheet 09 - Electro hydraulic

DV209B

Wiring harnesses - Electrical schematic sheet 14 - Lighting system

DV209B	
--------	--

Wiring harnesses - Electrical schematic sheet 19 - Cab

DV209B	
--------	--

Contents

Electrical systems - 55

Alternator - 301

TECHNICAL DATA

Alternator	
General specification (*)	3

(*) See content for specific models

5. Remove the bolts **(6)** which attaches the seat **(7)**.

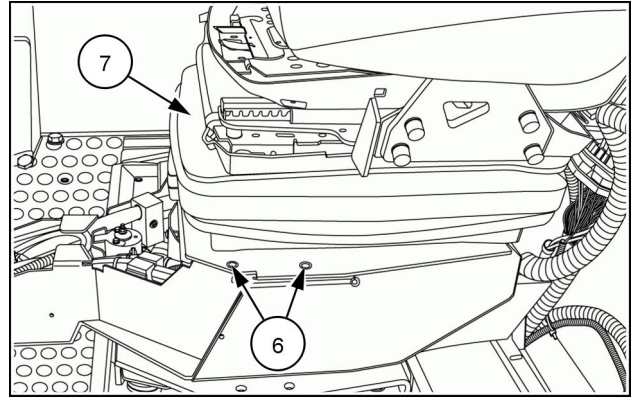

RAIL14COM0771AA 5

6. Lift the seat **(7)**.
7. Disconnect the connector **(X2)**.
8. Remove the operator presence switch **(8)** and wiring.

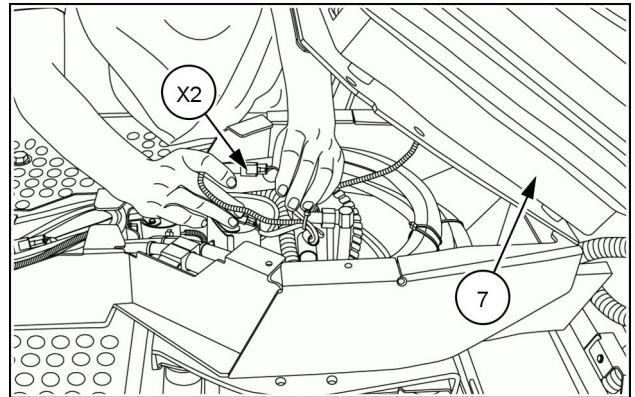

RAIL14COM0772AA 6



PRINTED IN U.S.A.

© 2016 CNH Industrial America LLC.

All rights reserved. No part of the text or illustrations of this publication may be reproduced.

CASE CONSTRUCTION policy is one of continuous improvement and the right to change prices, specification or equipment at any time without notices is reserved.

All data given in this publication is subject to production variations. Dimensions and weight are approximate only and the illustrations do not necessarily show products in standard condition. For exact information about any particular product, please consult your CASE CONSTRUCTION Dealer.

Left-hand side arm rest console

Switches

7. Install the switch (9) on the arm rest with the nut (10).

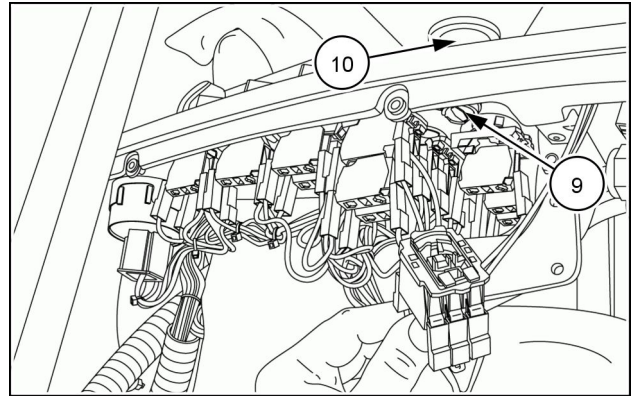

RAIL14COM0778AA 7

8. Install the receptacle (8) on the arm rest.

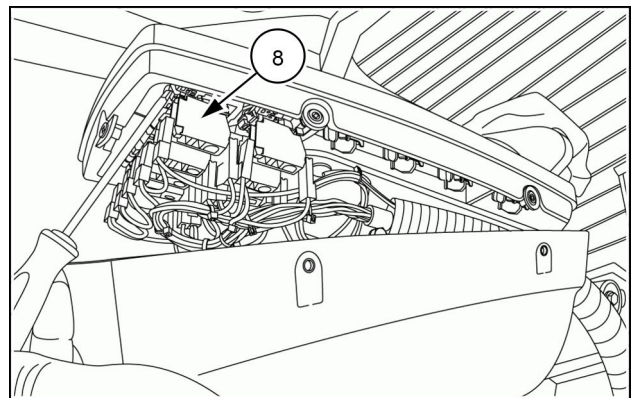

RAIL14COM0780AA 8

9. Install the cover (7).

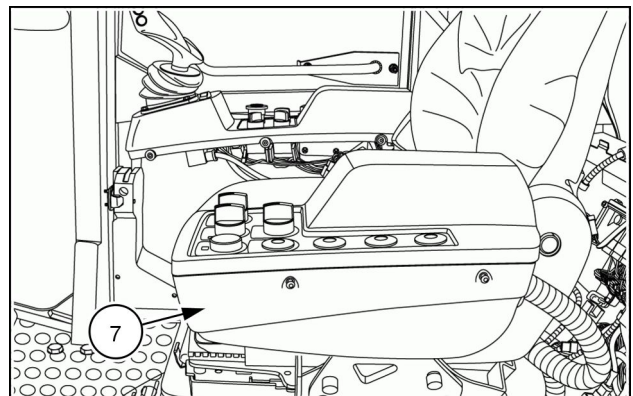

RAIL14COM0779AA 9

3. Install the right side of the cab on the platform with bolts (8) and (9).

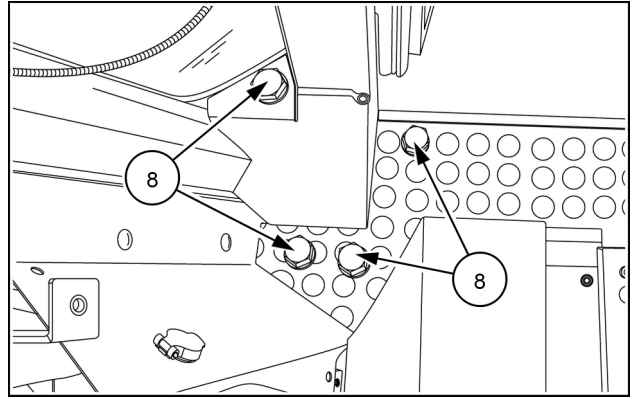

RAIL14COM0702AA 5

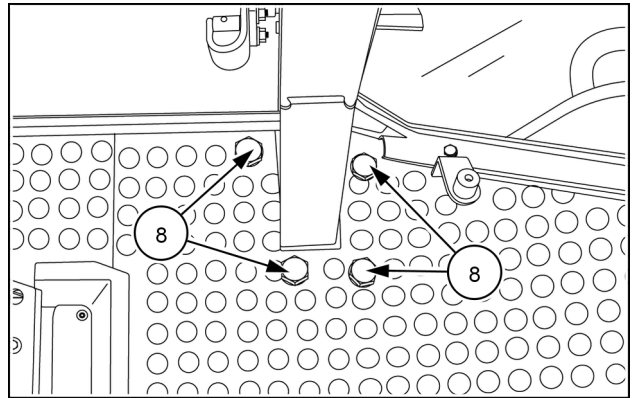

RAIL14COM0701AA 6

4. Remove the lifting device from the cab.
5. Install the bolts removed earlier.

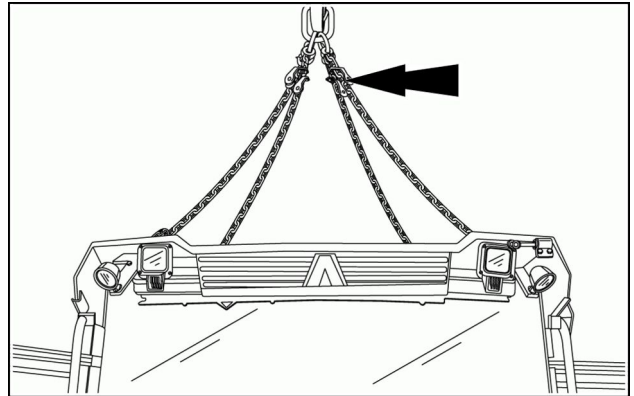

RAIL14COM0700AA 7

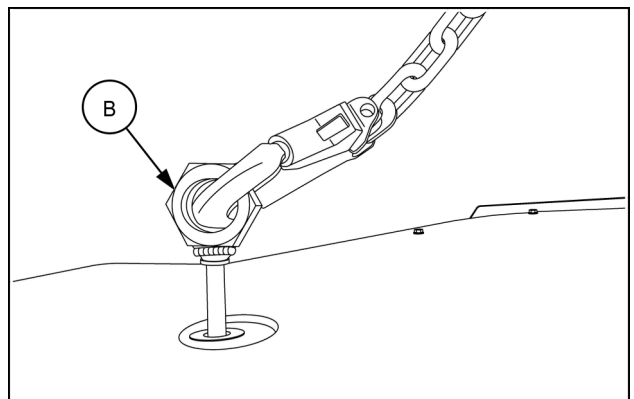

RAIL14COM0699AA 8

5. Place the platform in its correct position on the frame.

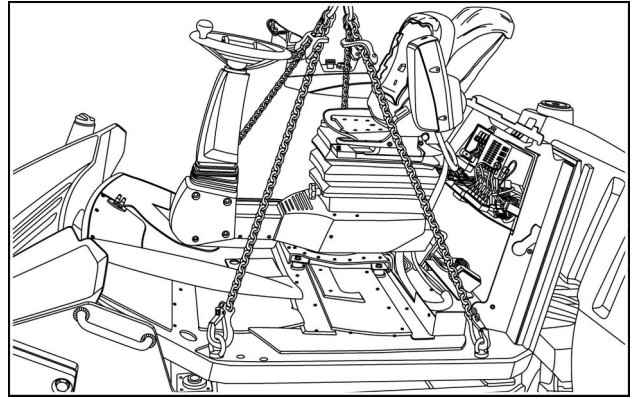

RAIL14COM0724AA 5

6. Remove the lifting lugs (D)

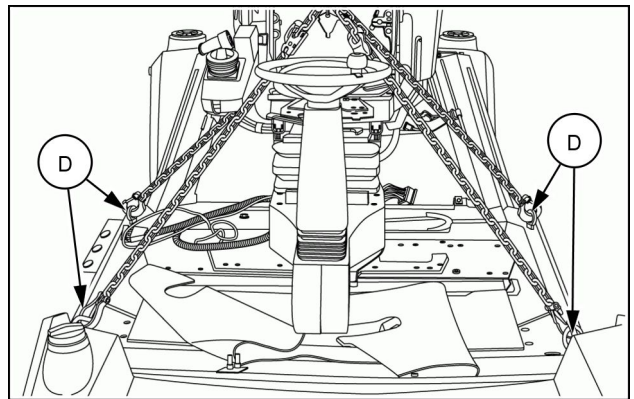

RAIL14COM0725AA 6

7. Install the platform on the frame with the bolts (17) and (18).

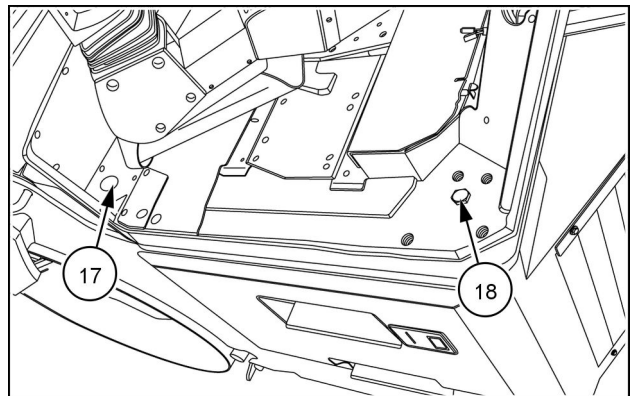

RAIL14COM0722AA 7

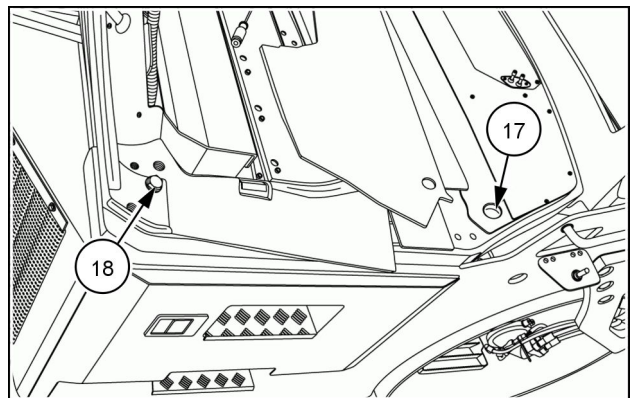

RAIL14COM0723AA 8

CLICK HERE TO **DOWNLOAD** THE COMPLETE MANUAL

- Thank you very much for reading the preview of the manual.
- You can download the complete manual from: www.heydownloads.com by clicking the link below



- Please note: If there is no response to CLICKING the link, please download this PDF first and then click on it.

CLICK HERE TO **DOWNLOAD** THE COMPLETE MANUAL