

**CX350C**  
Crawler Excavator

**SERVICE MANUAL**

Part number 48024426

English

May 2016

© 2016 CNH Industrial Italia S.p.A. All Rights Reserved.

**CASE**  
CONSTRUCTION

CLICK HERE TO **DOWNLOAD** THE COMPLETE MANUAL

- Thank you very much for reading the preview of the manual.
- You can download the complete manual from: [www.heydownloads.com](http://www.heydownloads.com) by clicking the link below



- Please note: If there is no response to CLICKING the link, please download this PDF first and then click on it.

CLICK HERE TO **DOWNLOAD** THE COMPLETE MANUAL

INTRODUCTION

**Air cleaner (double element)**

Manufacturer	Nippon Donaldson, Ltd.
Element (outer)	<b>12.7 m<sup>2</sup></b>
Element (inner)	<b>1.74 m<sup>2</sup></b>
Weight	<b>13 kg (28.6601 lb)</b>

**Pre\_cleaner**

Rain cap	
Manufacturer	Nippon Donaldson, Ltd.
Weight	<b>0.4 kg (0.8818 lb)</b>
Pre-cleaner	
Manufacturer	Nippon Donaldson, Ltd.
Weight	<b>3.5 kg (7.7162 lb)</b>
Pre-cleaner (auto-discharge type)	
Manufacturer	Nippon Donaldson, Ltd.
Weight	<b>1.5 kg (3.3069 lb)</b>

**Hydraulic device**

**Hydraulic pump**

Manufacturer		Kawasaki Heavy Industries, Ltd.
Main pump		
	Pump type	Double variable displacement piston pump
	Displacement capacity	<b>152 cm<sup>3</sup>/rev (9.276 in<sup>3</sup>/rev) x 2</b>
	Operating pressure	Rated <b>34.3 MPa (4975 psi)</b>
		Maximum <b>37.3 MPa (5337.84 psi)</b>
	Input revolution speed	<b>2000 RPM</b>
	Maximum discharge flow	<b>304 l/min (304.000 US gpm) x 2 (at Pd = 3.0 MPa (435.2 psi) 2000 RPM) 300 l/min (300.000 US gpm) x 2 (at Pd = 8.0 MPa (1160.4 psi) 2000 RPM)</b>
Pilot pump		
	Pump type	Gear pump
	Displacement capacity	<b>15 cm<sup>3</sup>/rev (0.92 in<sup>3</sup>/rev)</b>
	Operating pressure	<b>3.9 MPa (566 psi)</b>
	Maximum discharge flow	<b>30 l/min (30.00 US gpm) (at 2000 RPM)</b>
	Control method	Hydraulic simultaneous constant output control
		Maximum flow adjustment control through external commands (negative control)
		Maximum flow adjustment control through external command milli-amp (negative control, front side)
		Setting horsepower adjustment control through external command milli-amp
	Dry weight	<b>188 kg (414.4691 lb)</b>
		With power take-off <b>205 kg (451.9476 lb)</b>
Add-on pump		
	Manufacturer	KYB Corporation
	Pump type	Gear pump
	Displacement volume	<b>33.3 cm<sup>3</sup>/rev</b>
	Operating pressure	<b>20.6 MPa (2988.0 psi)</b>
	Input revolution speed	<b>2000 RPM</b>

## Product identification

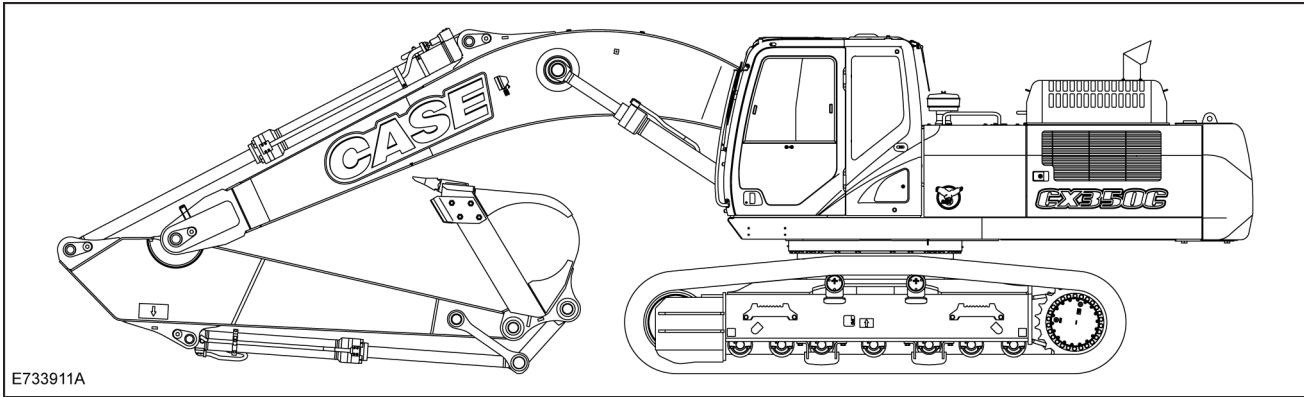

E733911A 1

When ordering parts, obtaining information or assistance, always supply your CASE CONSTRUCTION Dealer with the type and serial number of your machine or accessories.

Write the following in the spaces below: the type, serial number and year of manufacture of your machine, accessories and the serial numbers of the various hydraulic and mechanical components.

### Machine

(1) Type / Model and Category:  
(Hydraulic Excavator) CX350C.

(2) Product identification number:

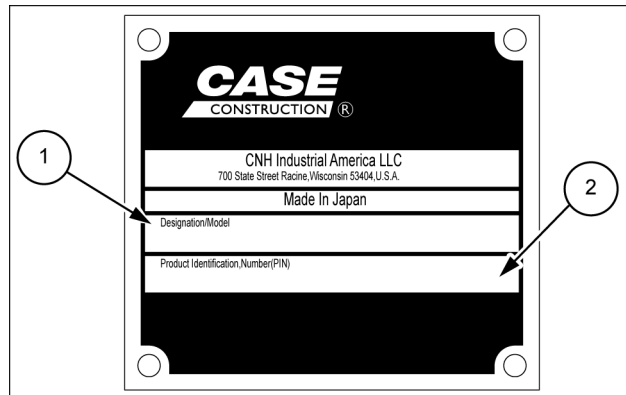

SMIL15CEXY711AB 2

4. Insert the compression gauge adapter (2) into the glow plug installation hole to install the compression gauge (1).

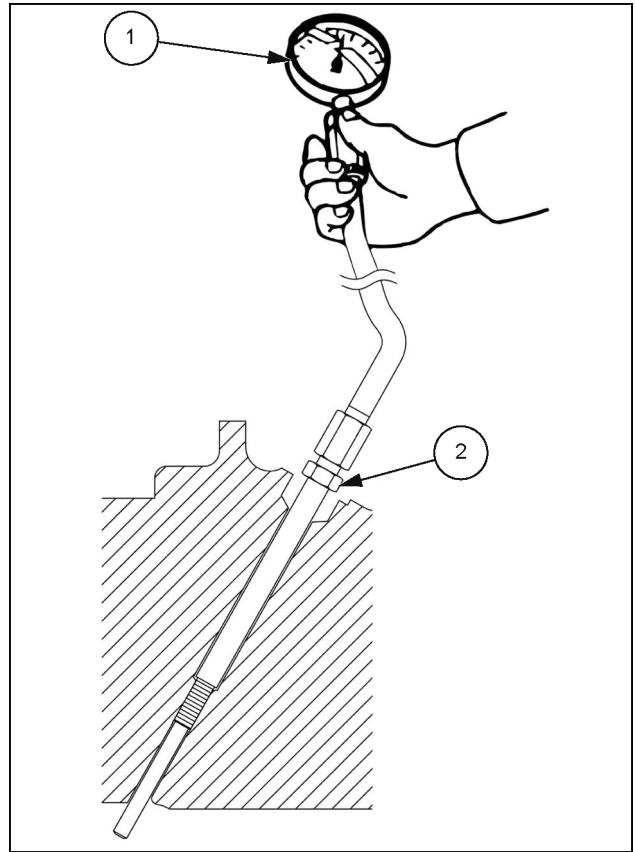

SMIL14CEX3447BB 4

5. To measure the compression pressure proceed as follows:

- Turn the starter and read the compression pressure when the compression gauge indicator is stable at about **200 RPM**.
- Measure the compression pressure for all cylinders.

Standard value: **3240 kPa (470 psi)**.

Limit value: **2260 kPa (328 psi)**.

Difference between each cylinder: **294 kPa (43 psi)**

**⚠ CAUTION:** Be careful of the streaming air blowing out from the glow plug hole while rotating.

**NOTE:** If the key switch is turned ON with the injector harness connector removed, the ECM judges that it is a malfunction and a diagnostic trouble code is set. Be sure to clear DTCs after the inspection is complete.

12. Apply the liquid gasket to the crankcase.

Bead width: **3 - 4 mm (0.118 - 0.157 in)**

Bead height: **3 - 4 mm (0.118 - 0.157 in)**

**NOTE:** Apply *ThreeBond 1207B* to the crankcase thoroughly so that there is no break in application of the bead.

**NOTICE:** After applying the liquid gasket, install the crankcase within **5 min.**

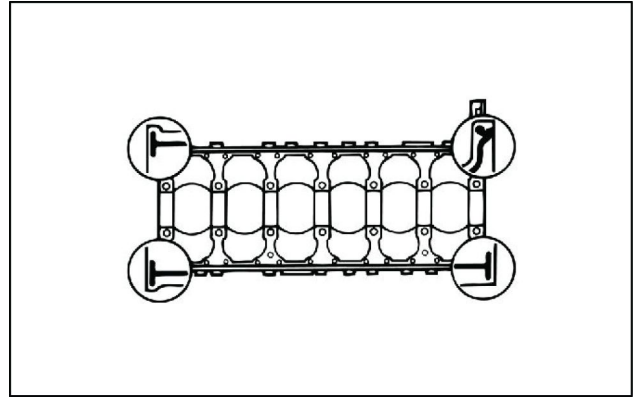

LPIL12CX03681AA 13

13. Put the crankcase on the cylinder block.

**NOTICE:** Be careful not to let the thrust bearing fall.

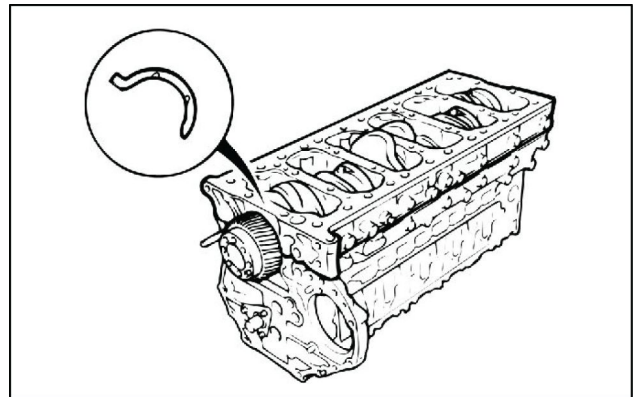

LPIL12CX03682AA 14

14. Apply the disulfide molybdenum grease to the bolt.

**NOTE:** Apply to the threaded portion and seat surface on the **M14** bolt for crankcase installation.

**NOTICE:** Do not apply grease to the **M10** bolt.

**NOTE:** Tightening order

15. Tighten the bolt using the torque wrench.

Tightening torque: **98 N·m (72 lb ft) M14** bolt

16. Tighten the bolt using the torque wrench.

Tightening torque: **132 N·m (97.4 lb ft) M14** bolt

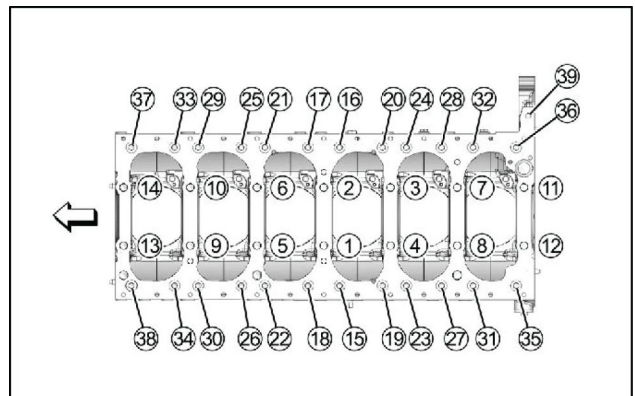

LPIL12CX03683AA 15

17. Tighten the bolt using the special tool.

Special tool: Angle gauge (refer to **Cylinder heads - Special tools (10.101)**)

Tightening angle: **30 ° M14** bolt

18. Tighten the bolt using the torque wrench.

Tightening torque: **37 N·m (27.3 lb ft) M10** bolt

19. Tighten the bolt using the torque wrench.

Tightening torque: **142 N·m (104.7 lb ft)** Check the tightening **M14** bolt

**NOTICE:** Confirm that the crankshaft turns smoothly after tightening the bolts.

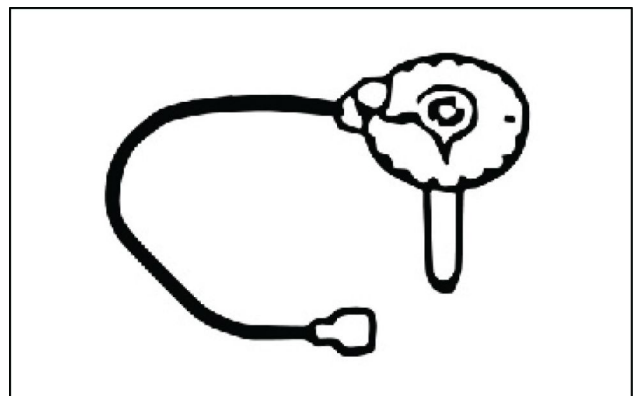

SMIL13CEX1640AA 16

- Adjust the drive belt to standard value using the adjust bolt (1).

Tightening torque: **75 N·m (55 lb ft)** nut of the adjust plate

Tightening torque: **126 N·m (93 lb ft)** bolt of the bracket side

- Adjuster bolt
- Adjust plate side nut
- Bracket side bolt

**NOTE:** After adjusting, tighten the adjuster plate side nut and bracket side bolt to the specified torque.

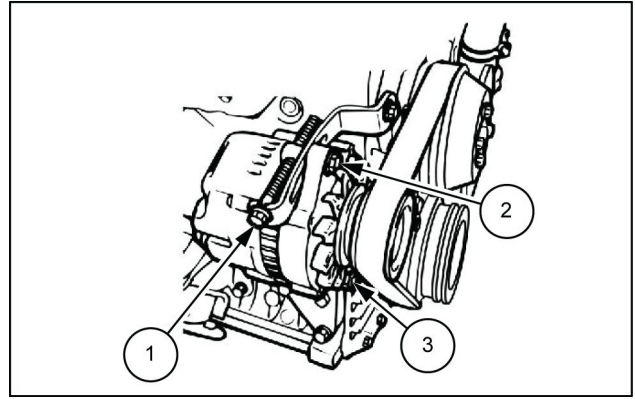

LPIL12CX03878AB 105

### Fan guide installation

- Install the fan guide bracket to the engine assembly.

Tightening torque: **40 N·m (30 lb ft)**

- Install the fan guide (6) to the fan guide bracket.

Tightening torque: **30 N·m (22 lb ft)**

- Bolt
- Washer
- Rubber mount
- Rubber mount
- Guide tube
- Fan guide

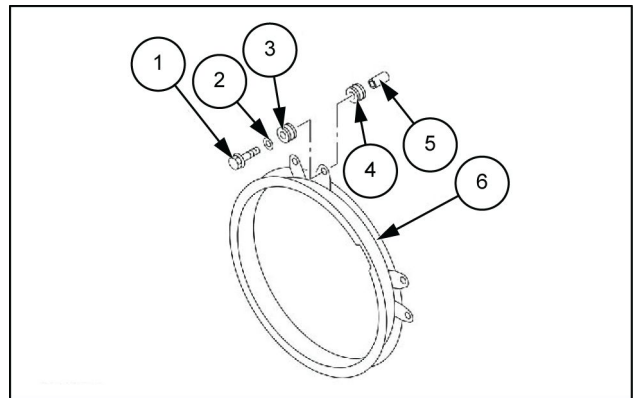

SMIL13CEX1824AB 106

### Cooling fan installation

- Install the cooling fan (1) to the adapter (2).

Tightening torque: **52 N·m (38 lb ft)**

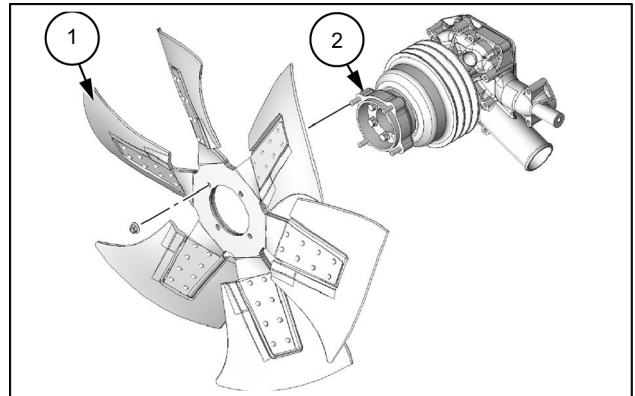

SMIL15CEX5063AB 107

### Engine harness connect

- Connect the engine harness to the engine assembly.

**NOTE:** Connect each connector.

### Engine oil filling

- Replenish the engine assembly with the engine oil.

**NOTICE:** Check that the drain plug is tightened to the specified torque before refilling the engine oil.

7. Temporarily tighten the camshaft bearing cap to the rocker arm shaft.

**NOTE:** Temporarily tighten the camshaft bearing cap on the front.

Temporarily tighten while in the assembly and completely tighten when installing the cylinder head.

1. Front mark

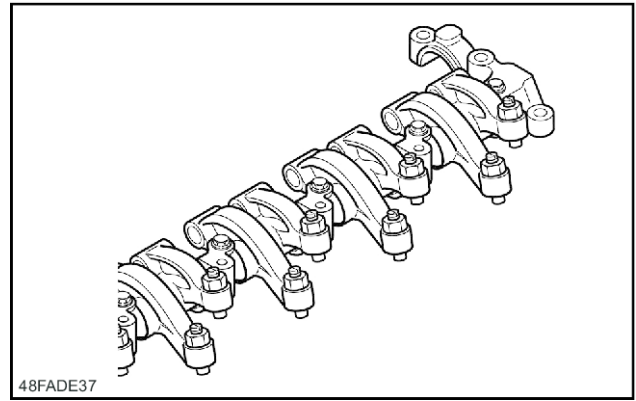

48FADE37

48FADE37 5

### Starter assembly installation

1. Install the starter assembly to the flywheel housing.  
Tightening torque: **82 N·m (60 lb ft)**
2. Connect the earth cable to the starter assembly.  
Tightening torque: **19 N·m (14 lb ft)**

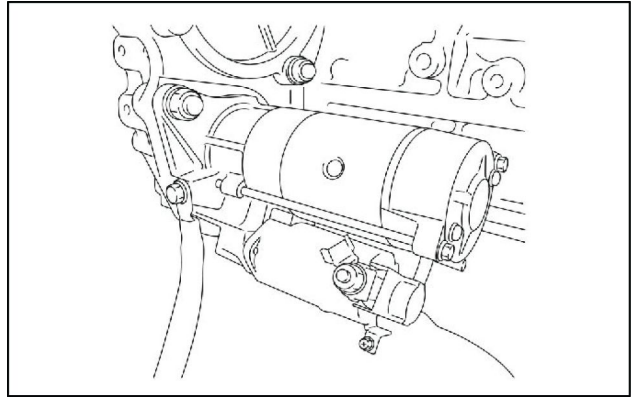

LPIL12CX03813AA 23

### Fuel supply pump installation

1. Align 1st cylinder to the compression top dead center.
2. Align alignment mark to the bracket.
  1. Supply pump bracket side slit
  2. Supply pump gear side alignment mark

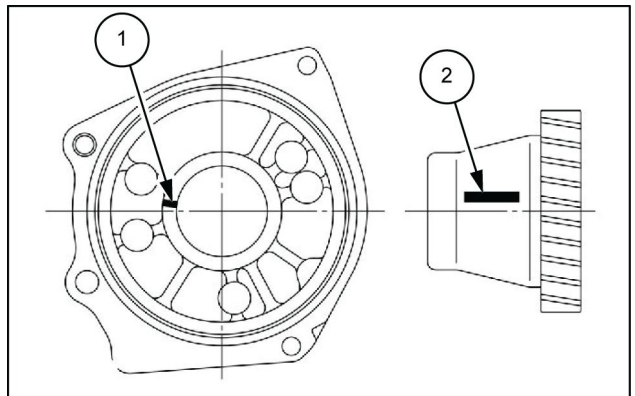

LPIL12CX03814AA 24

3. Align the fuel supply pump to the cylinder block.
  1. Confirmation hole
  2. Supply pump gear

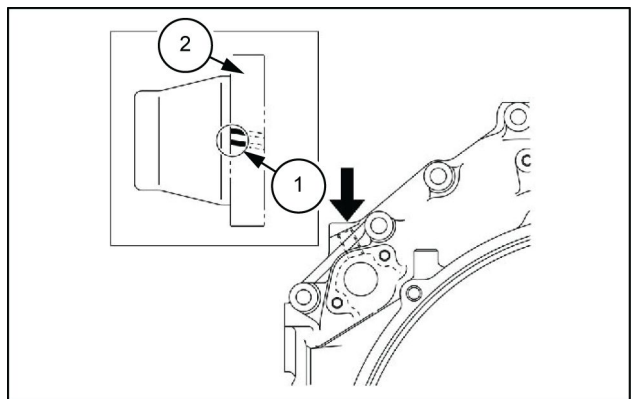

LPIL12CX03815AB 25

# Contents

---

## Engine - 10

### Cylinder heads - 101

#### TECHNICAL DATA

Cylinder heads	
Special tools .....	3
Cylinder head	
Special tools .....	4
Valves	
Special tools .....	6
Valve guide	
Special tools .....	7

#### SERVICE

Valve cover	
Remove .....	8
Install .....	9
Cylinder head	
Remove .....	10
Disassemble .....	20
Inspect .....	27
Assemble .....	33
Install .....	46
Valves	
Seal - Remove .....	61
Seal - Install .....	65
Spring - Remove .....	72
Spring - Inspect .....	76
Spring - Install .....	77

1. Inspect the cylinder head assembly.

NOTE:

- Installation surface of the cylinder head gasket
- Combustion chamber
- Exhaust port
- Valve seat
- Glow plug hole

 **CAUTION:** Replace the cylinder head if damage such as a crack has been found in the inspection.

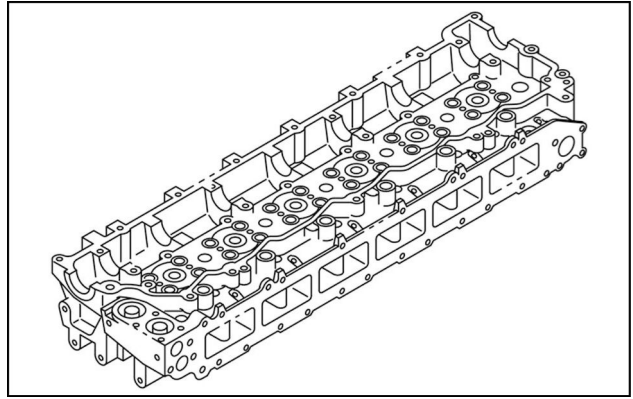

SMIL14CEX3119AA 17

**NOTE:** Fix it if it is possible.

2. Perform dye penetrant check.

**NOTE:** Check if there is a problem which cannot be detected by visual inspection.

3. Align the simple straight ruler to the cylinder head assembly.
4. Measure the clearance using the feeler gauge.

**NOTE:** Flatness of the bottom of the cylinder head.

Measurement part: 6 section(s)

Limit: **0.2 mm (0.0079 in)**

5. Inspect the water leak using the water pressure tester.

Specified pressure: **490 kPa (71 psi)**

Specified time: **3 min**

**NOTE:** Perform a hydraulic test with the injector holder installed.

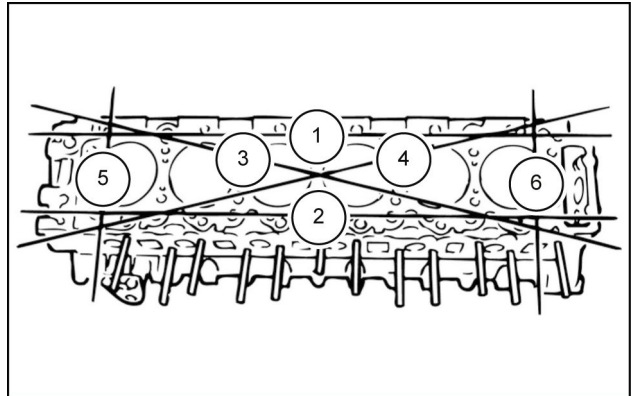

SMIL14CEX3120AB 18

2. Disconnect the terminal nut (3) of the injector harness (2) from the injector (1).

**CAUTION:** Be careful not to damage the injector side stud bolts.

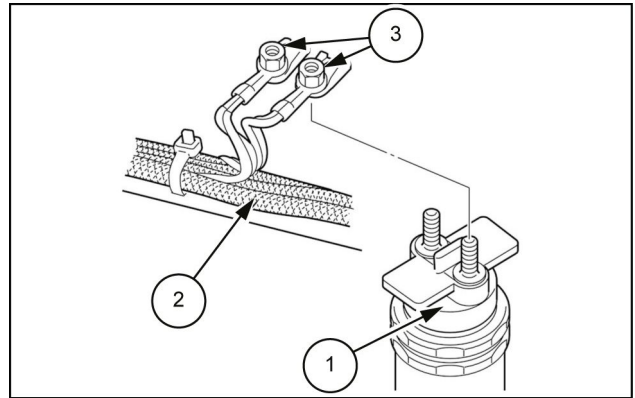

SMIL14CEX3003AB 4

3. Remove the injector harness from the cylinder head assembly.

**NOTE:** Remove the bracket tightening bolts and then remove the injector harness together with the bracket.

1. Injector harness terminal
2. Injector harness bracket

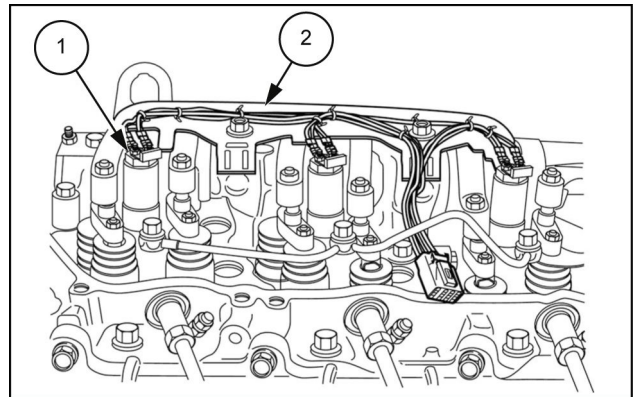

SMIL14CEX3004AB 5

### Lower cover removal

1. Remove the lower cover from the cylinder head assembly.
2. Remove the rubber plug from the cylinder head assembly.

### Rocker arm shaft removal

1. Loosen the adjust screw using a wrench.

**NOTE:** Loosen all valve clearance adjustment screws.

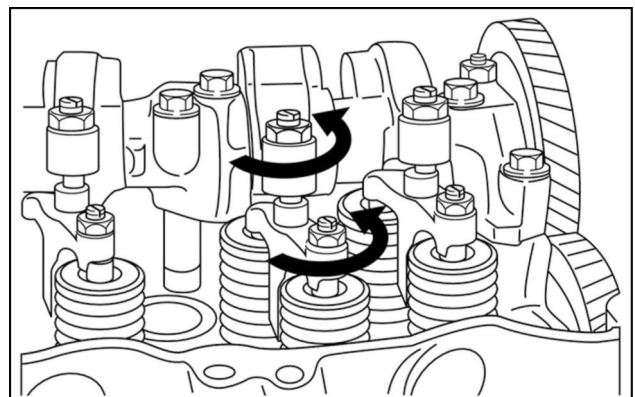

SMIL14CEX3009AA 6

3. Remove the EGR cooler water pipe from the engine assembly.

1. EGR cooler water pipe
2. EGR cooler water pipe

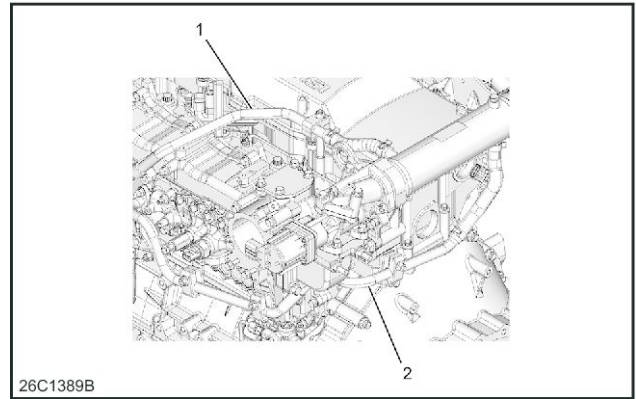

26C1389B 10

3. Remove the water bypass hose (1) from the water pump assembly and water duct.

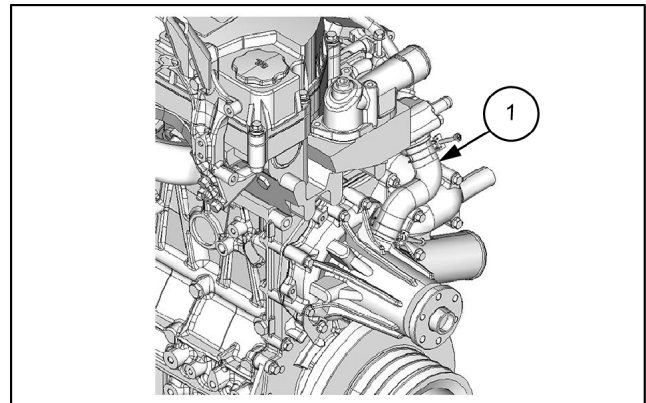

SMIL15CEX6560AB 11

### Oil level gauge guide tube removal

1. Remove the oil level gauge from the oil level gauge guide tube (1).
2. Disconnect the oil level gauge guide tube (1) from the front engine hanger bracket.
3. Remove the oil level gauge guide tube (1) from the cylinder block.

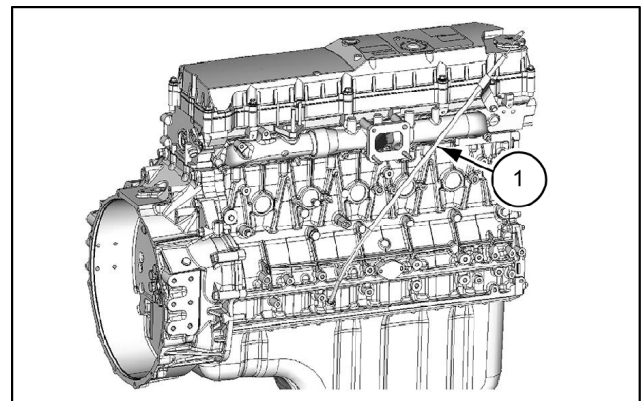

SMIL15CEX6561AB 12

## Glow plug installation

1. Install the glow plug to the cylinder head assembly.

Tightening torque: **20 N·m (14.8 lb ft)**

**NOTICE:** Be careful not to exceed the specified torque when tightening.

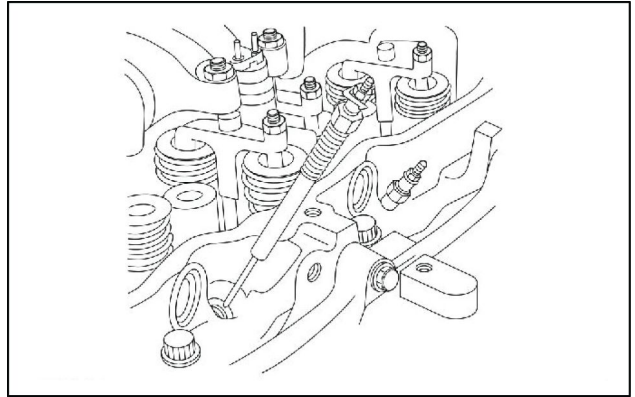

SMIL13CEX1801AB 28

2. Install the glow plug connector to the glow plug.

Tightening torque: **1 N·m (8.9 lb in)**

**NOTICE:** Confirm that the glow plug connector does not interfere with the surrounding parts.

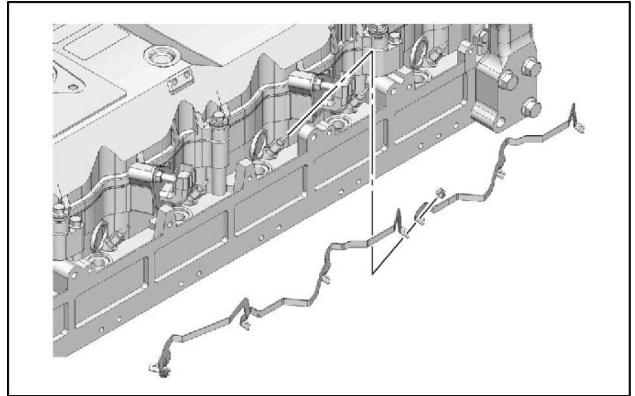

LPIL12CX03854AA 29

## Injector harness installation

1. Install the injector harness to the cylinder head assembly.

Tightening torque: **22 N·m (16 lb ft)**

**NOTE:** Tighten the bolts on the bracket and install the injector harness together with the bracket.

1. Injector harness terminal
2. Injector harness bracket

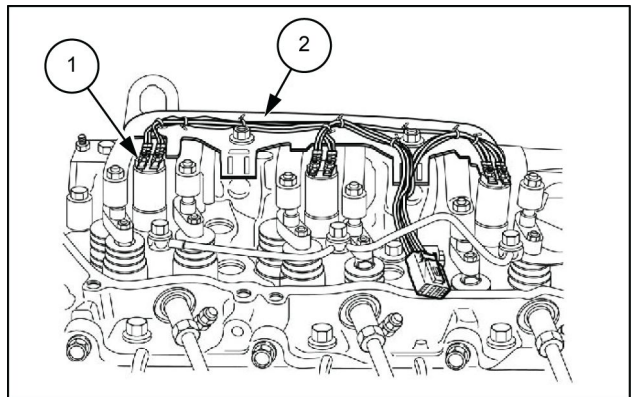

LPIL12CX03855AB 30

2. Connect the injector harness (2) to the injector (1).

3. Terminal nut

**NOTICE:** Be careful not to damage the injector (1) side stud bolts.

3. Install the connector to the lower cover.

Tightening torque: **2 N·m (18 lb in)**

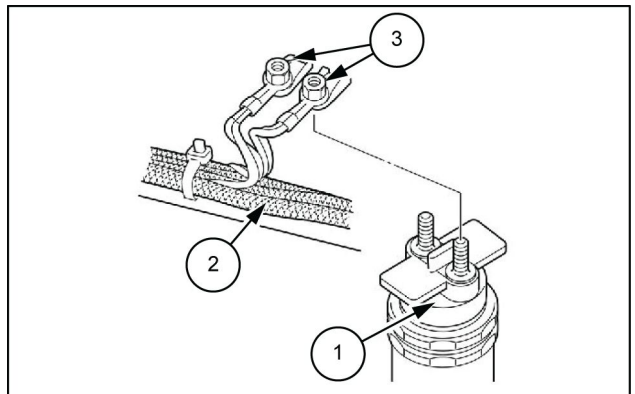

LPIL12CX03856AB 31

## Crankshaft - Remove

### Battery ground cable disconnect

1. Disengage the battery ground cable from the battery.

**NOTICE:** Do not disconnect the battery cable at least for **1 min** after turning the starter switch off.

### Coolant drain

1. Drain the coolant from the radiator.

**NOTICE:** After the coolant is discharged, make sure to tighten the drain plug.

### Engine oil drain

1. Remove the drain plug from the oil pan.
2. Drain the engine oil from the oil pan.
3. Install the drain plug to the oil pan.

Tightening torque: **70 N·m (51.63 lb ft)**

### Engine harness disconnect

1. Disengage the engine harness from the engine assembly.

**NOTE:** Disconnect each connector.

### Cooling fan removal

1. Remove the cooling fan (1) from the adapter (2).

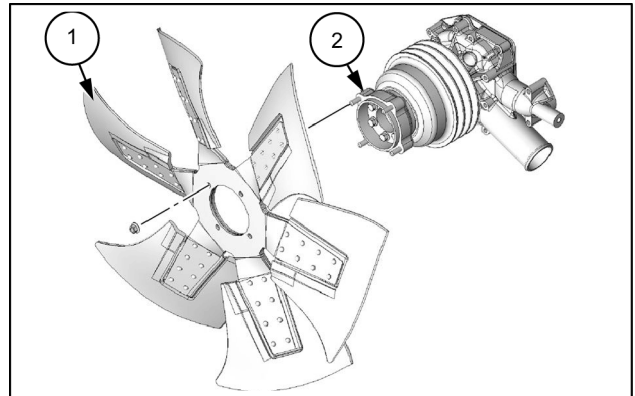

SMIL15CEX5063AB 1

### Fan guide removal

1. Remove the fan guide (6) from the fan guide bracket.
2. Remove the fan guide bracket from the engine assembly.

1. Bolt
2. Washer
3. Rubber mount
4. Rubber mount
5. Guide tube

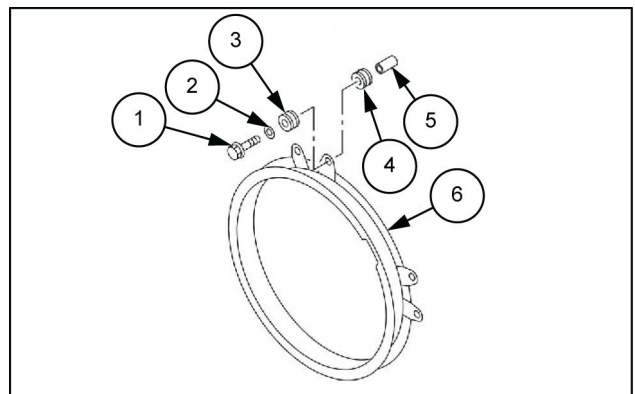

SMIL13CEX1467AB 2

## Piston installation

1. Install the connecting rod bearing to the connecting rod.

1. Application of engine oil

2. Apply the engine oil to the connecting rod bearing.

**NOTICE:** Apply engine oil only to the internal diameter of the connecting rod bearing.

3. Apply the engine oil to the piston ring.

4. Apply the engine oil to the piston.

- Thoroughly apply engine oil to the ring grooves and piston side surface.

5. Adjust the piston ring.

- Shift each piston ring joint by the specified angle.  
Specified angle: 90°

6. Apply the engine oil to the cylinder liner.

7. Install the special tool to the piston.

Special tool: piston setting tool (Refer to **Piston - Special tools (10.105)** )

8. Align the piston to the cylinder block.

- Turn the piston so that the front mark faces the engine front.

9. Press the piston.

**NOTICE:** To avoid damaging the oil jet, place the crank pin on the cylinder on which the piston will be installed at top dead center.

To avoid damaging the piston ring, firmly attach the piston installer to the cylinder block and push it.

Be careful not to damage the crank pin and cylinder liner. Attach a stopper so that the liner does not protrude.

1. No.1 compression ring joint
2. No.2 compression ring joint
3. Oil ring joint
4. Front mark

10. Install the connecting rod bearing to the connecting rod bearing cap.

11. Apply the engine oil to the connecting rod bearing.

**NOTICE:** Apply engine oil only to the internal diameter of the connecting rod bearing.

Do not apply engine oil to the rear surface of the bearing or bearing installation surface of the connecting rod.

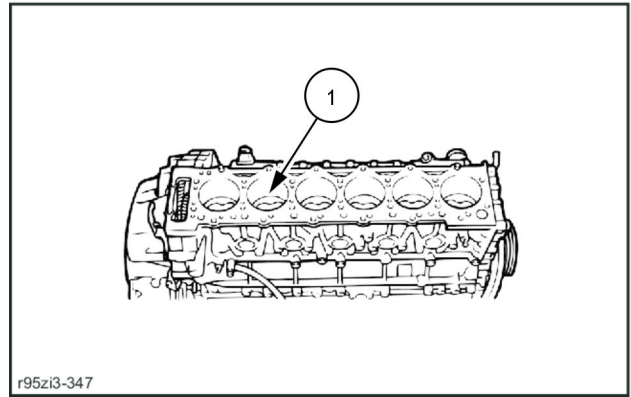

R95Z13-347 11

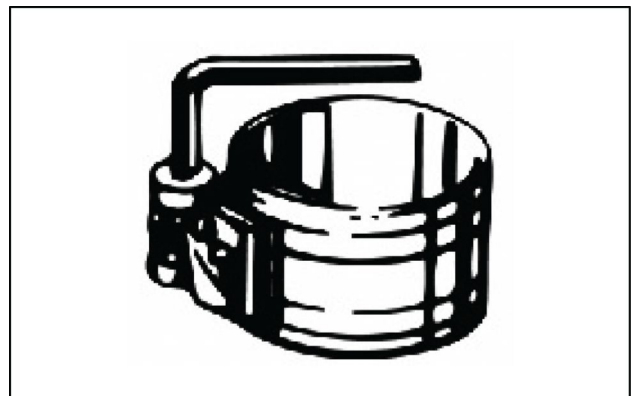

SMIL13CEX1641AA 12

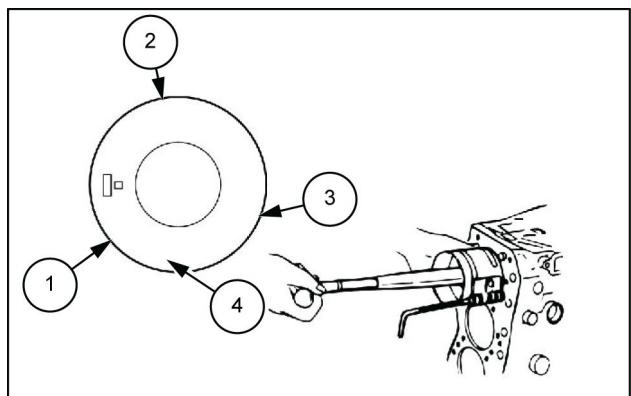

SMIL13CEX1642AB 13

## Drive belt adjustment

1. Press the drive belt.

**NOTICE:** Measure the deflection of the drive belt when the section marked with the arrow in the diagram is pressed with the specified force.

Specified value: **98 N·m (72.3 lb ft)**

Specified value: **5.5 - 7.5 mm (0.2165 - 0.2953 in)**  
amount of flex

1. Crankshaft pulley
2. Generator
3. Fan pulley

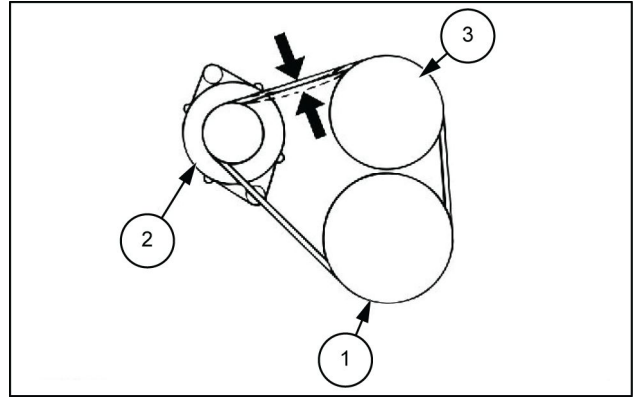

SMIL13CEX1822AB 96

2. Adjust the drive belt to the standard value using the adjust bolt.

**NOTICE:** Loosen the adjuster plate side nut (2) and bracket side bolt (3) in the diagram, and then lightly tighten to the seating position.

Adjust the deflection of the belt to the standard value with the adjuster bolt (1).

After adjusting, tighten the adjuster plate side nut and bracket side bolt to the specified torque.

Tightening torque: **75 N·m (55 lb ft)** nut of the adjust plate

Tightening torque: **126 N·m (93 lb ft)** bolt of the bracket side

1. Adjust bolt
2. Adjust plate side nut
3. Bracket side bolt

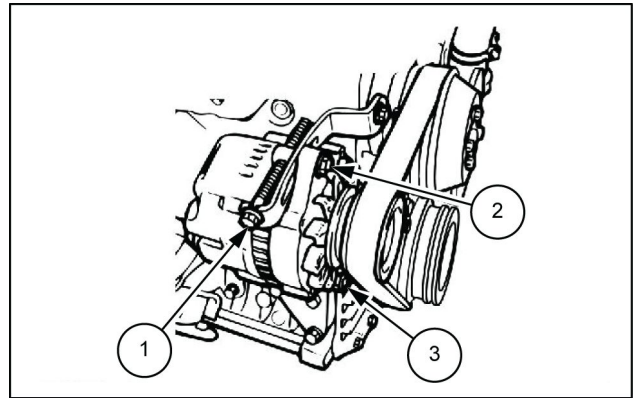

SMIL13CEX1823AB 97

## Fan guide installation

1. Install the fan guide bracket to the engine assembly.  
Tightening torque: **40 N·m (30 lb ft)**
2. Install the fan guide to the fan guide bracket.  
Tightening torque: **30 N·m (22 lb ft)**

1. Bolt
2. Washer
3. Rubber mount
4. Rubber mount
5. Guide tube
6. Fan guide

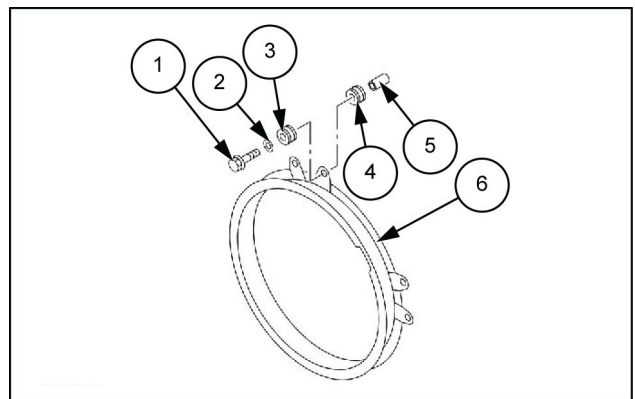

SMIL13CEX1824AB 98

## Fuel supply pump (type 2)

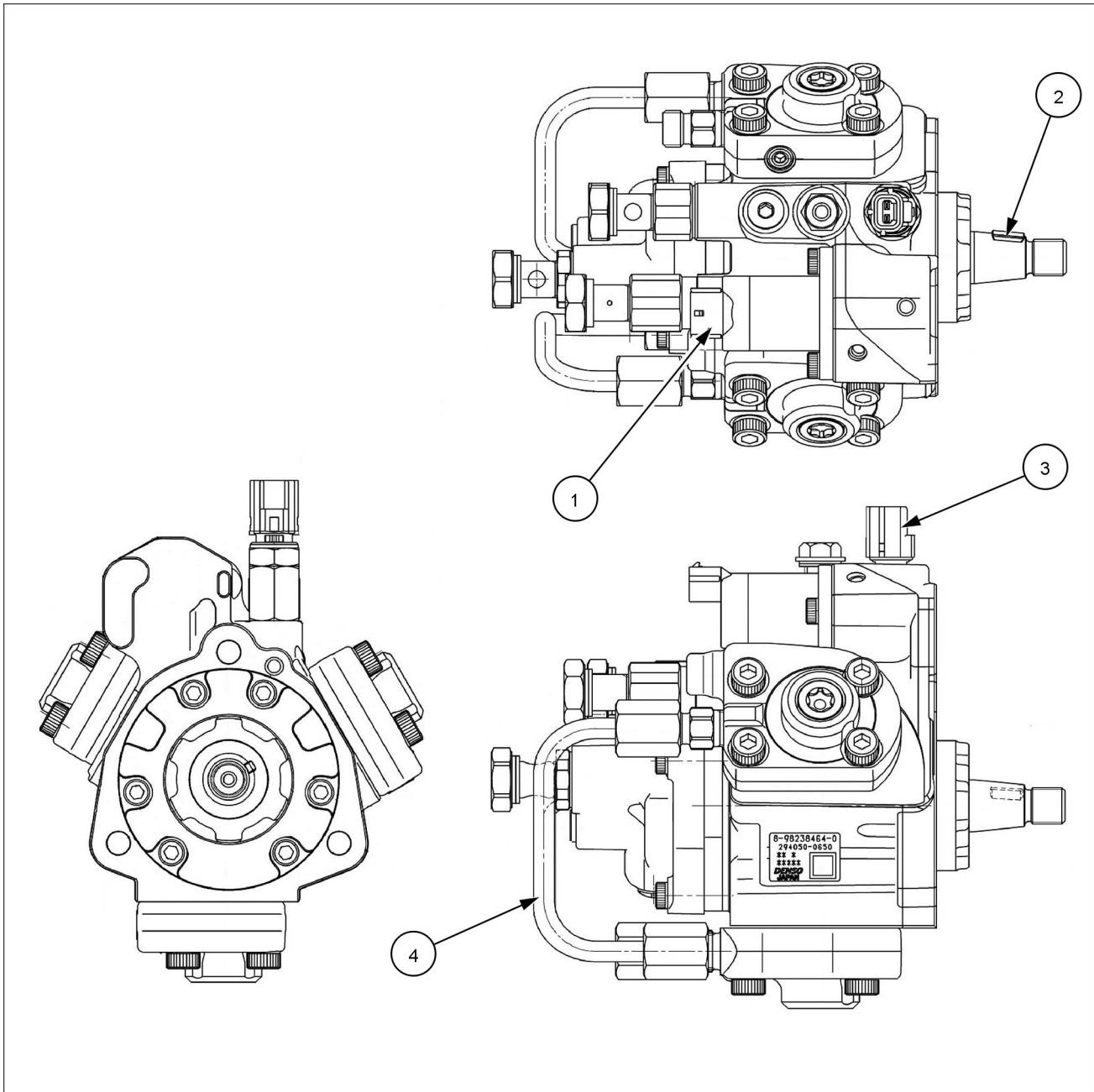

SML15CEX6848G 2

- 1. Suction control valve
- 2. Camshaft
- 3. Fuel temperature sensor
- 4. High-pressure pipe

# Contents

---

## Engine - 10

### Turbocharger and lines - 250

#### FUNCTIONAL DATA

Turbocharger	
Component identification .....	3

#### SERVICE

Turbocharger	
Remove .....	4
Install .....	5

# Index

---

## Engine - 10

### Intake and exhaust manifolds and muffler - 254

Exhaust manifold - Inspect .....	16
Exhaust manifold - Install .....	17
Exhaust manifold - Remove .....	12
Exhaust muffler - Install .....	25
Exhaust muffler - Prepare .....	23
Exhaust muffler - Remove .....	24
Intake manifold - Install .....	7
Intake manifold - Remove .....	3

---

## Water pump - Inspect

1. Inspect the water pump assembly.
  - Cracks and damage on the water pump body
  - Cracks and corrosion on the impeller
  - Water leak from the seal unit

**NOTICE:** *If any abnormality is found in the inspection, replace the water pump assembly.*

2. Inspect the bearing unit.
  - Rotate the fan while pushing the fan center to the radius direction and inspect for any significant looseness or abnormal sounds.

**NOTICE:** *If any abnormality is found in the inspection, replace the water pump assembly.*



LPIL12CX00953AA 1

### Removing the oil level gauge guide tube

1. Remove the oil level gauge from the oil level gauge guide tube.
2. Disconnect the oil level gauge guide tube from the front engine hanger bracket.
3. Remove the oil level gauge guide tube from the cylinder block.
  1. Oil level gauge guide tube

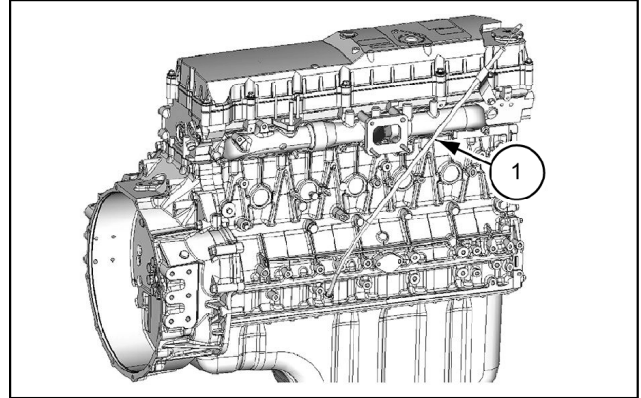

SMIL15CEX6561AB 11

### Removing the glow plug

1. Remove the glow plug connector from the glow plug.

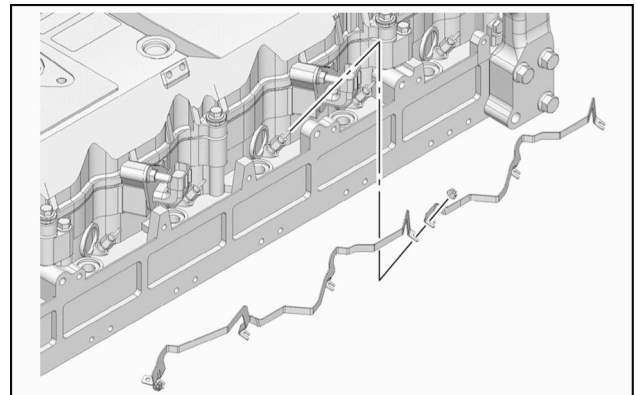

SMIL14CEX2997AA 12

2. Remove the glow plug from the cylinder head assembly.

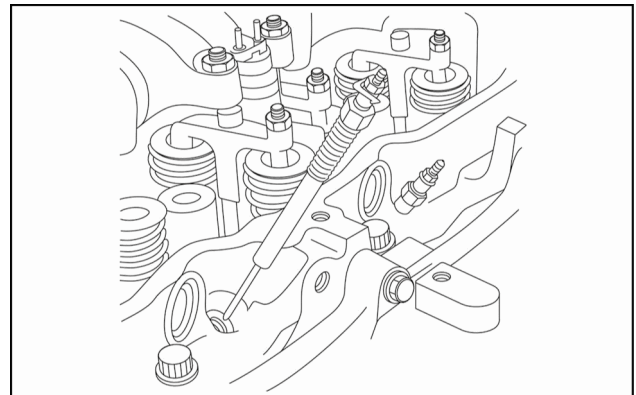

SMIL14CEX2998AA 13

## Lower cover installation

1. Apply the liquid gasket (2) to the rubber plug (1) .

**NOTE:** Apply *ThreeBond 1207B*.

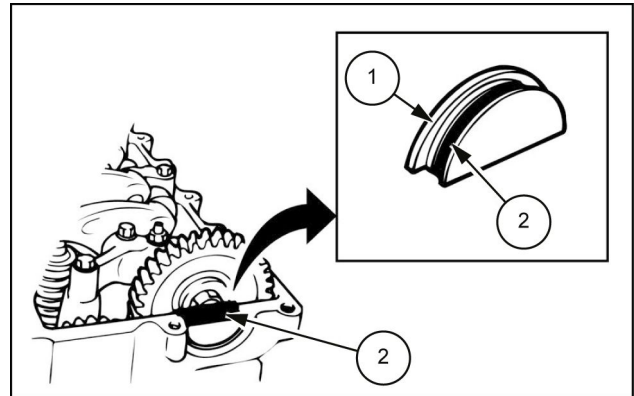

SMIL14CEX3084AB 38

2. Install the rubber plug to the cylinder head.

**NOTICE:** After applying the liquid gasket, install the lower cover within **5 min**.

3. Install the gasket to the lower cover.
4. Install the lower cover to the cylinder head.

Tightening torque: **13 N·m (115 lb in)**

**NOTE:** Tightening order.

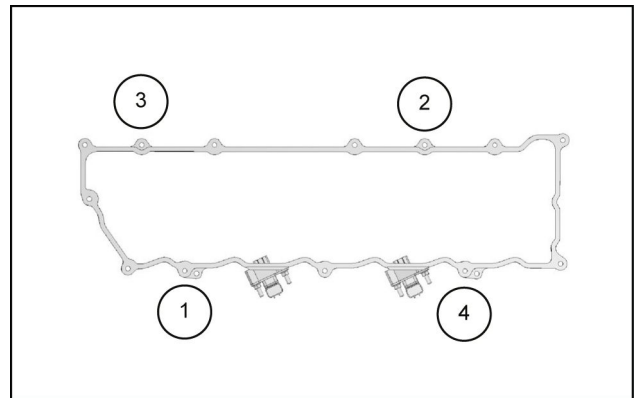

SMIL14CEX3087AB 39

## Common rail assembly installation

1. Align the common rail assembly (1) with the adapter.
2. Temporarily tighten the bolts to the common rail assembly.
3. Temporarily tighten the nuts in the common rail assembly.
4. Fully tighten the bolts in the common rail assembly.

Tightening torque: **25 N·m (18.4 lb ft)**

5. Fully tighten the nuts in the common rail assembly

Tightening torque: **25 N·m (18.4 lb ft)**

6. Connect the harness connector to the fuel pressure sensor.

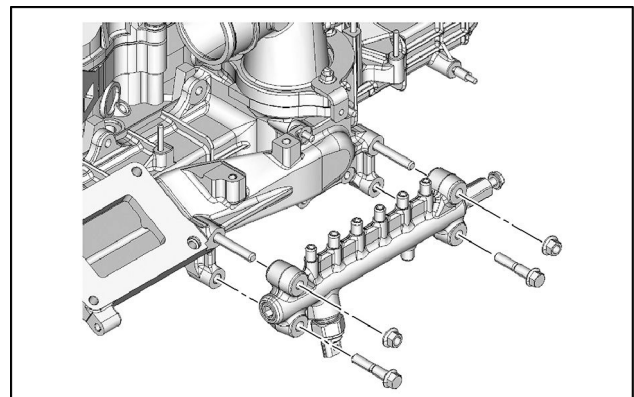

SMIL15CEX6563AA 40

# Contents

---

## Hydraulic systems - 35

[35.000] Hydraulic systems.....	35.1
[35.300] Reservoir, cooler, and filters.....	35.2
[35.104] Fixed displacement pump.....	35.3
[35.106] Variable displacement pump .....	35.4
[35.102] Pump control valves.....	35.5
[35.359] Main control valve.....	35.6
[35.357] Pilot system .....	35.7
[35.355] Hydraulic hand control .....	35.8
[35.356] Hydraulic foot control.....	35.9
[35.352] Hydraulic swing system .....	35.10
[35.353] Hydraulic travel system .....	35.11
[35.354] Hydraulic central joint .....	35.12
[35.736] Boom hydraulic system .....	35.13
[35.737] Dipper hydraulic system.....	35.14
[35.738] Excavator and backhoe bucket hydraulic system.....	35.15
[35.360] Hammer and rotating bucket hydraulic system .....	35.16

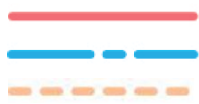

Pressure line

Tank line

Pilot pressure line



Pilot tank line

Electric line

1. Swing motor
2. Swing
3. Cushion valve
4. Right swing
5. Left swing
6. Swing pilot pressure sensor
7. Remote control valve (arm, swing)
8. Control valve
9. Travel pilot pressure sensor
10. Upper pilot pressure sensor
11. Computer A
12. Lever lock
13. Swing brake
14. 5 stack solenoid valve
15. Console lever lock switch
16. P1 pressure sensor
17. P1 flow control proportional valve
18. Hydraulic pump
19. Horsepower control proportional valve
20. P2 pressure sensor
21. Check valve
22. Oil cooler
23. Swing motor relief valve
24. Pilot piston



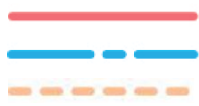

Pressure line

Tank line

Pilot pressure line





Pilot tank line



Electric line

1. Boom load holding valve check valve
2. Load holding valve spool
3. Cushion valve
4. Boom (up)
5. Boom (down)
6. Remote control valve (boom, bucket)
7. Lever lock
8. Pressure boost relief
9. 4 stack solenoid valve
10. Control valve
11. Check valve
12. Oil cooler
13. Boom cylinder

14. Boom **(1)**
15. Travel pilot pressure sensor
16. Upper pilot pressure sensor
17. Console lever lock switch
18. Monitor display
19. Computer A
20. P1 pressure sensor
21. P2 pressure sensor
22. Hydraulic pump
23. HBCV check valve
24. Regeneration orifice
25. Bleed-off
26. HBCV



 Pressure line  
 Tank line  
 Pilot pressure line

 Pilot tank line  
 Electric line

- |                                 |  |
|---------------------------------|--|
| 1. Control valve                | 10. Hydraulic pump                     |
| 2. Hydraulic fork               | 11. 2 stack reducing valve             |
| 3. Travel pilot pressure sensor | 12. Option pilot pressure switch       |
| 4. Upper pilot pressure sensor  | 13. Check valve                        |
| 5. Monitor display              | 14. Oil cooler                         |
| 6. Computer A                   | 15. P1 flow control proportional valve |
| 7. Lever lock                   | 16. Relief valve                       |
| 8. 4 stack solenoid valve       | 17. Stop valve                         |
| 9. Console lever lock switch    | 18. Proportional switch                |

Pressure gauge port size: G1/4 for **10 MPa**  
(**1450 psi**)

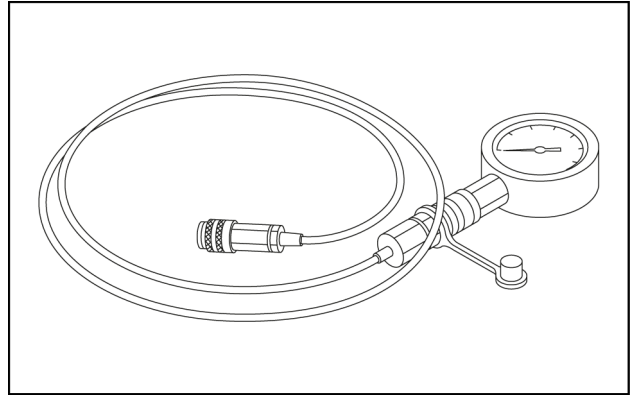

SMIL14CEX2098AA 32

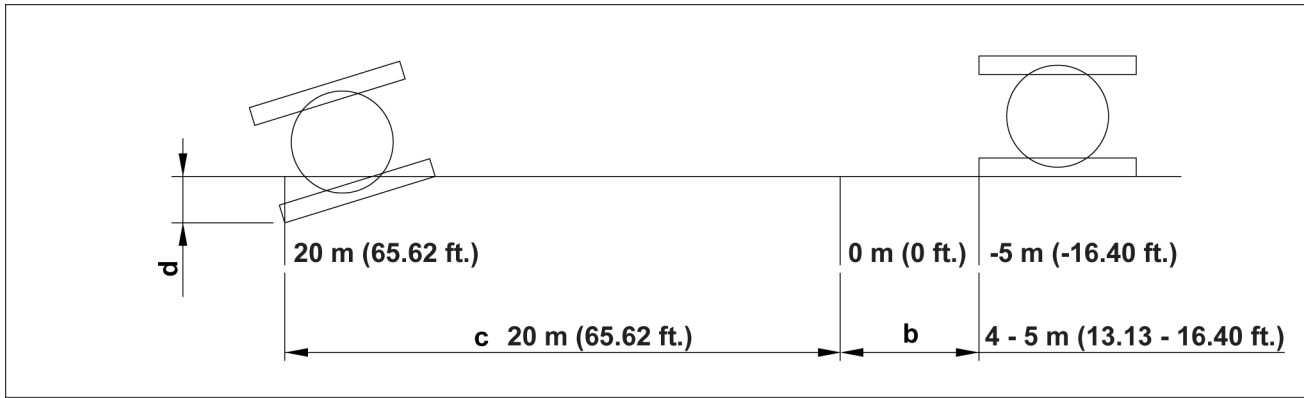

SMIL15CEX1679EB 9

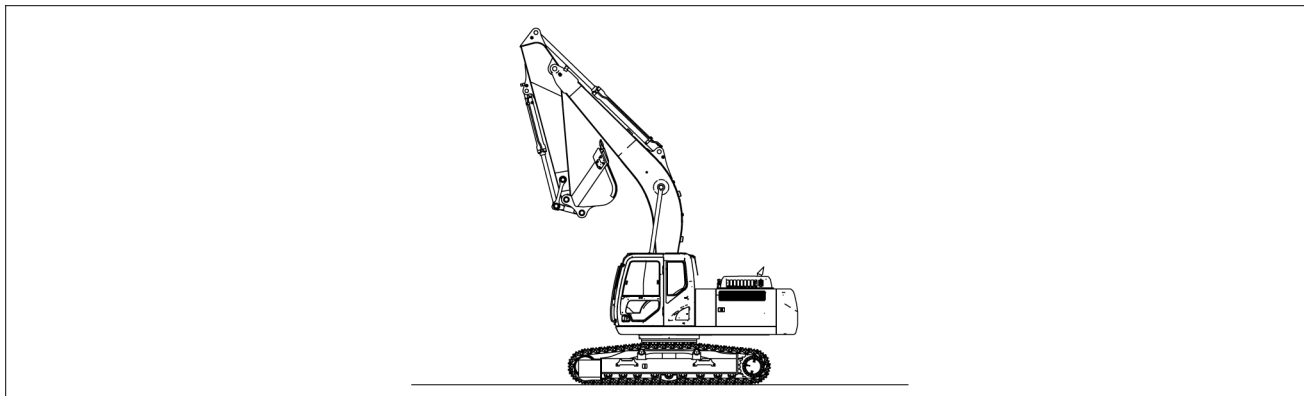

SMIL15CEX1680EB 10

**Measurement posture**

**Travel sprocket speed**

Measurement method

1. Engine high idle.
2. Oil temperature is **45 - 55 °C (113 - 131 °F)**.
3. Raise a shoe, and after achieving a constant speed, measure the time required for the sprocket to rotate 10 times both forwards and backwards.
4. Measure for both high-speed and low-speed traveling.

Main unit posture: **90 °** swing, shoe raised.

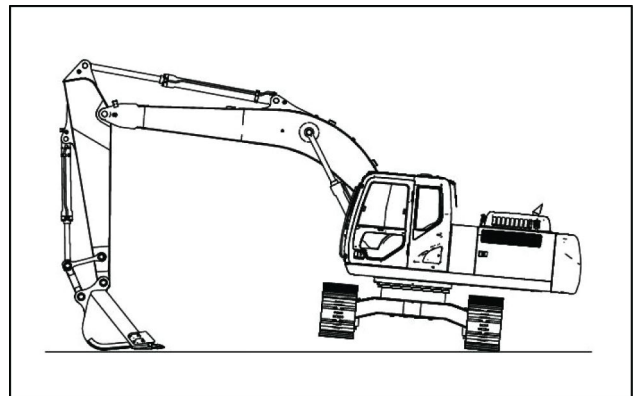

LPIL12CX00051AA 11



10. Install the seal cover **(F) (261)** to the pump casing **(271)**, and secure with the hexagon socket head bolts **(406)**.

- Apply a thin layer of grease to the oil seal inside the seal cover **(F)**.
- Be careful not to damage the oil seal when installing it.

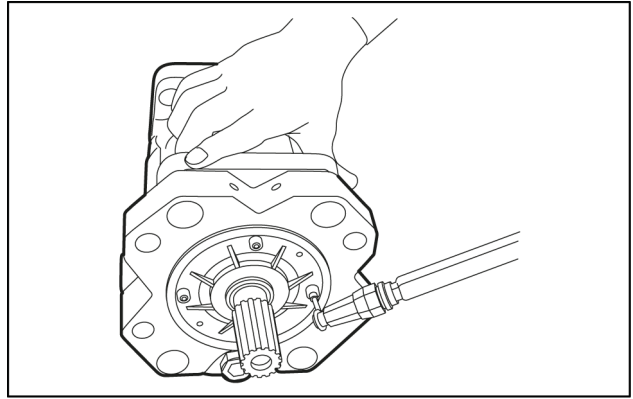

SMIL14CEX1566AA 4

11. Assemble the piston cylinder subassembly [cylinders **(141)**, pistons **(151)** and **(152)**, holder plates **(153)**, spherical bushings **(156)**, spacers **(158)**, cylinder springs **(157)**], and then insert it into the pump casing in alignment with the phase of the splines of the spherical bushings and cylinder blocks.

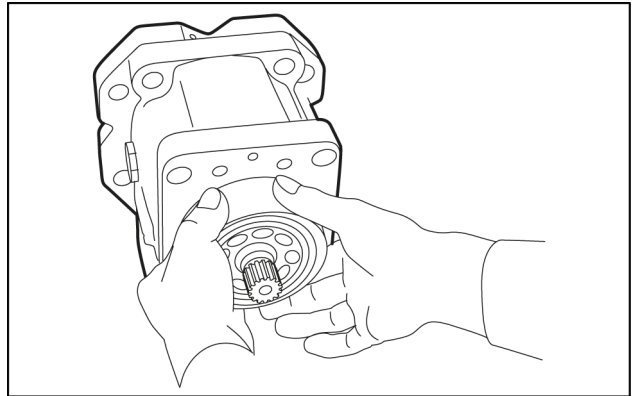

SMIL14CEX1567AA 5

12. Install the valve plate **(313)** on the valve block **(312)** while aligning it with the pin **(885)**.

- Be careful not to mistake the suction and discharge directions of the valve plates.

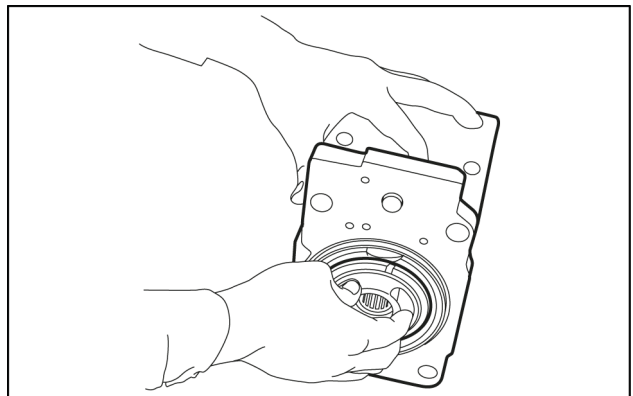

SMIL14CEX1568AA 6

13. Install the valve block **(312)** on the pump casing **(271)**, and then tighten it with the hexagon socket head bolts **(401)**.

- Assembly is easier when starting with the rear side pump.
- Install the valve block in the correct direction. (Install the valve block so that the regulator faces up and the suction flange faces right when looking at the valve block from the front.)
- Insert the 1st gear into the valve block beforehand and couple it with the drive shaft joint section spline.

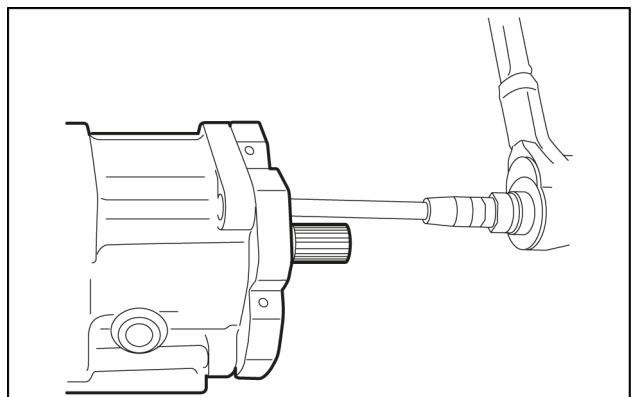

SMIL14CEX1569AA 7

# Contents

---

## Hydraulic systems - 35

### Main control valve - 359

#### FUNCTIONAL DATA

Main control valve	
Overview .....	3
Dynamic description .....	6
Stacked control valves	
Component diagram .....	44

#### SERVICE

Main control valve	
Prepare .....	53
Remove .....	55
Install .....	60
Stacked control valves	
Disassemble .....	61
Cleaning .....	68
Inspect .....	69
Assemble .....	70
Main pressure control valve	
Disassemble .....	78
Assemble .....	82
Adjust .....	86
Install .....	87
Check .....	88

#### DIAGNOSTIC

Stacked control valves	
Troubleshooting .....	89
Main pressure control valve	
Troubleshooting .....	90

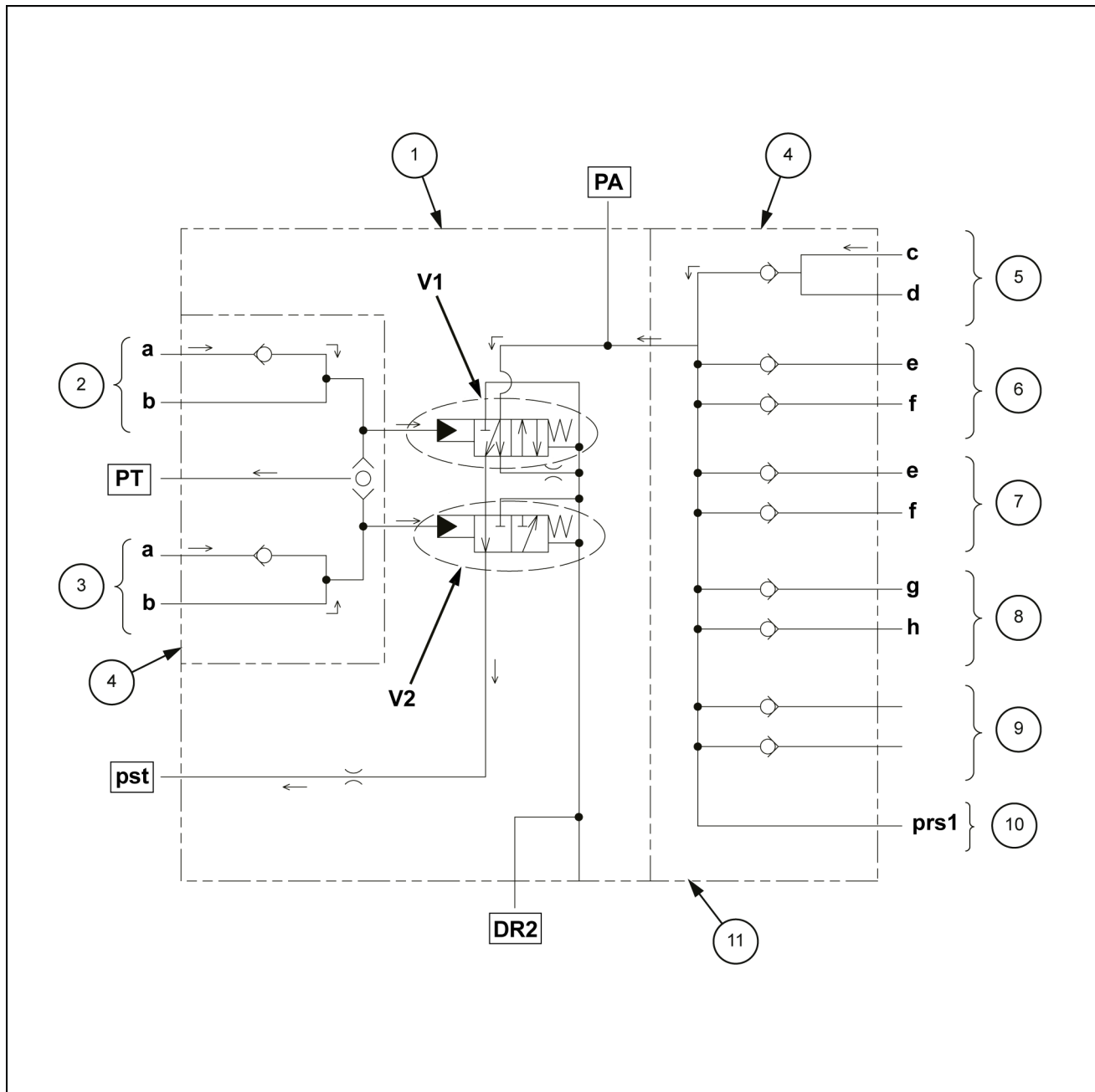

SMIL15CEX3649GB 23

- |   |  |
|---|--|
| 1. Straight travel signal control valve | 7. Bucket                              |
| 2. Travel 1                             | 8. Swing                               |
| 3. Travel 2                             | 9. Reserve                             |
| 4. Plate assembly                       | 10. Add-on (main pump)                 |
| 5. Boom                                 | 11. Main unit housing section (option) |
| 6. Arm                                  |  |

### b. Main unit circuit

When the straight travel spool is switched, the oil fed from the P1 port flows from the neutral path (L1) to travel (section 1) and at the same time passes through path (2), the straight travel spool neck section, and the neutral path (R1) and into travel (section 6), and feeding to travel left and right becomes possible.

On the other hand, when the oil fed from the P2 port flows to the parallel path (R3), at the same time it passes through the straight travel spool neck section and path (1) and into the parallel path (L3), so it becomes possible to feed oil to the entire front system.

## Removal of long cap and pull out of main spool

- Loosen the hexagon socket head bolts **(74)** [ **8 mm** hexagon socket diameter] for the 9 caps **(8)** and the 1 cap **(9)**, and remove them.  
When pulling out the spool only, do not loosen the **M6** screws on the plate except for the 4 hexagon socket head bolts **(75)** and the 1 hexagon socket head bolt **(94)** fastening the plate assemblies.
- Loosen and remove the plugs **(91)** [ **19 mm** hexagon diameter] attached to the ports as necessary.
- Remove the O-rings **(7)** (1 in each section) from the plate assemblies **(10)** and **(11)**.
- Pull out each spool from the valve housing still in the sub-assembly state.

### ⚠ CAUTION:

- When pulling out the spool, be careful not to cause any dents or scratches.
  - Identify each spool with a shipping tag so that there will be no mistake about their positions when they are re-assembled.
- Loosen and remove the hexagon socket head bolts **(75)** [ **8 mm** hexagon socket diameter ] and hexagon socket head bolts **(94)** [ **5 mm**] hexagon socket diameter] those fastens the plate assemblies **(10)**, **(11)**, **(28)** and **(29)** to the housing.  
Remove the plate assemblies still in the assembly state. Do not disassemble them.
  - Loosen and remove the plugs **(91)** [ **19 mm** hexagon socket diameter] as necessary.
  - Remove the O-rings **(7)** and **(41)** from the valve housings **(1)** and **(13)**.

### ⚠ CAUTION:

- In order to avoid damaging the outer edge of the spool, sandwich the spool with wooden blocks (as in the diagram on the right) and fasten with a vise before starting the work.
- Since adhesive is applied to the spool end thread section, heat up the outer edge of the spool thread section to break down the adhesive.
- Heat so that the spool heating temperature is **200 - 250 °C (392.0 - 482.0 °F)**.  
Heat until the spool end loosens easily immediately after the heating.
- If overheating occurs, replace the spring with a new one. (Wooden blocks for spool assembly/disassembly)

L1. **30 - 40 mm (1.18 - 1.57 in)**

L2. **3 - 6 mm (0.12 - 0.24 in)**

L3. **70 - 100 mm (2.76 - 3.94 in)**

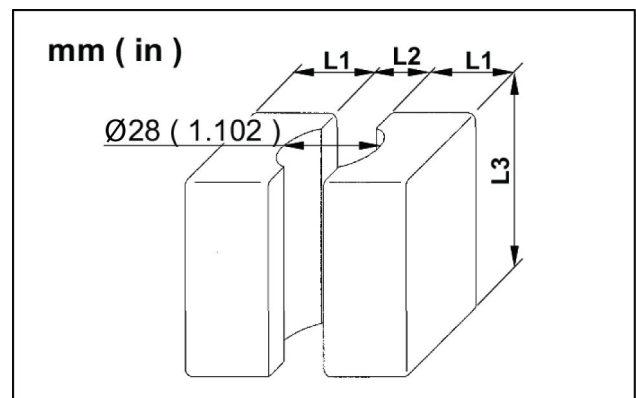

LPIL12CX02776AA 1



**When the handle is held (See Fig. 4)**

When the handle is tilted and the pressure of the ports ( 2, 4) rises to a pressure equivalent to the set spring force (241), the hydraulic pressure and the spring force are in balance. When the ports ( 2, 4) pressure becomes higher than the set pressure, the ports ( 2, 4) and the P port (2) close and the ports ( 2, 4) and the T port (1) open. When the ports ( 2, 4) pressure becomes lower than the set pressure, the ports ( 2, 4) and the P port (2) open and the ports ( 2, 4) and the T port (1) close, so the secondary pressure is held constant.

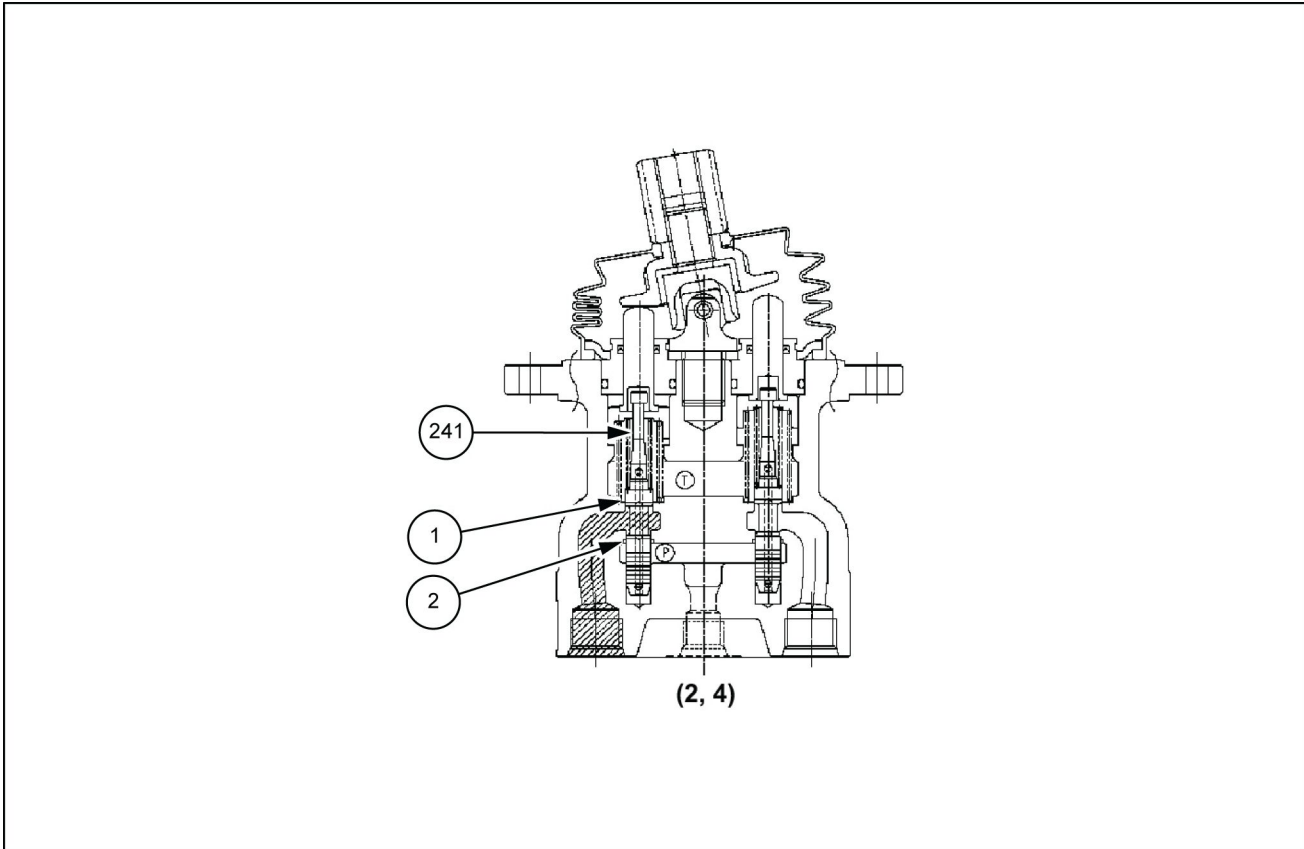

LPIL12CX01996FB 4

**When handle held (secondary pressure at or above set pressure)**

1. T port	2. P port
-----------	-----------

**Operation in area in which the handle tilt is large (depends on the model)**

For certain models, when the handle is flipped down beyond a certain angle, the spool top end section touches the push rod bore bottom section and the output pressure goes into the state of still being connected with the P port pressure.

Furthermore, with the structure in which the spring seating and spring are installed inside the push rod, when the handle is flipped down beyond a certain angle, the push rod bore bottom section and the spring touch. That spring force changes the 2<sup>nd</sup> pressure gradient and after that the push rod bore bottom section and the spring seating top end section touch, and the output pressure remains connected to the P port.

## Cleaning

Clean all parts by placing them in a rough cleaning container filled with white kerosene. (rough cleaning)

Clean each part by placing it in a finish cleaning container filled with white kerosene, and thoroughly clean each part, including the interior, while slowly rotating the part. (finish cleaning)

Use a clean rag to thoroughly remove any white kerosene stuck to parts.

- Scratching can easily occur if cleaning of a part is begun just after parts are immersed in white kerosene, so let each part sit in white kerosene until debris and grease sufficiently loosen from the surface of the part and float to the surface.
- If the white kerosene is dirty, this will encourage damage to parts and result in reduced performance after reassembly. Thoroughly manage the level of cleanliness of the white kerosene.
- Do not dry parts with compressed air, as this will damage parts and cause rust to form due to debris and moisture being dispersed into the atmosphere.

## Preventing rust on parts

Apply an anti-rust agent to each part.

- Rust will form on parts if they are left as is after cleaning, and this will cause reduced performance of functions after reassembly.

## Pedal control - Dynamic description

### Operation

The remote control valve with built-in damper (hereinafter, remote control valve with damper) is a remote control valve that incorporates into the remote control valve main unit a damping function for preventing the man-machine system hunting (lever hunting) phenomenon.

Operation of the remote control valve with damper is divided into the pressure reduction valve section and the operation section damping mechanism section. The explanations in these 2 sections are based on the hydraulic circuit diagram, assembly cross-section diagram, and damping operation explanation diagram below. The diagram below is a typical usage example for the remote control valve.

### Hydraulic circuit diagram

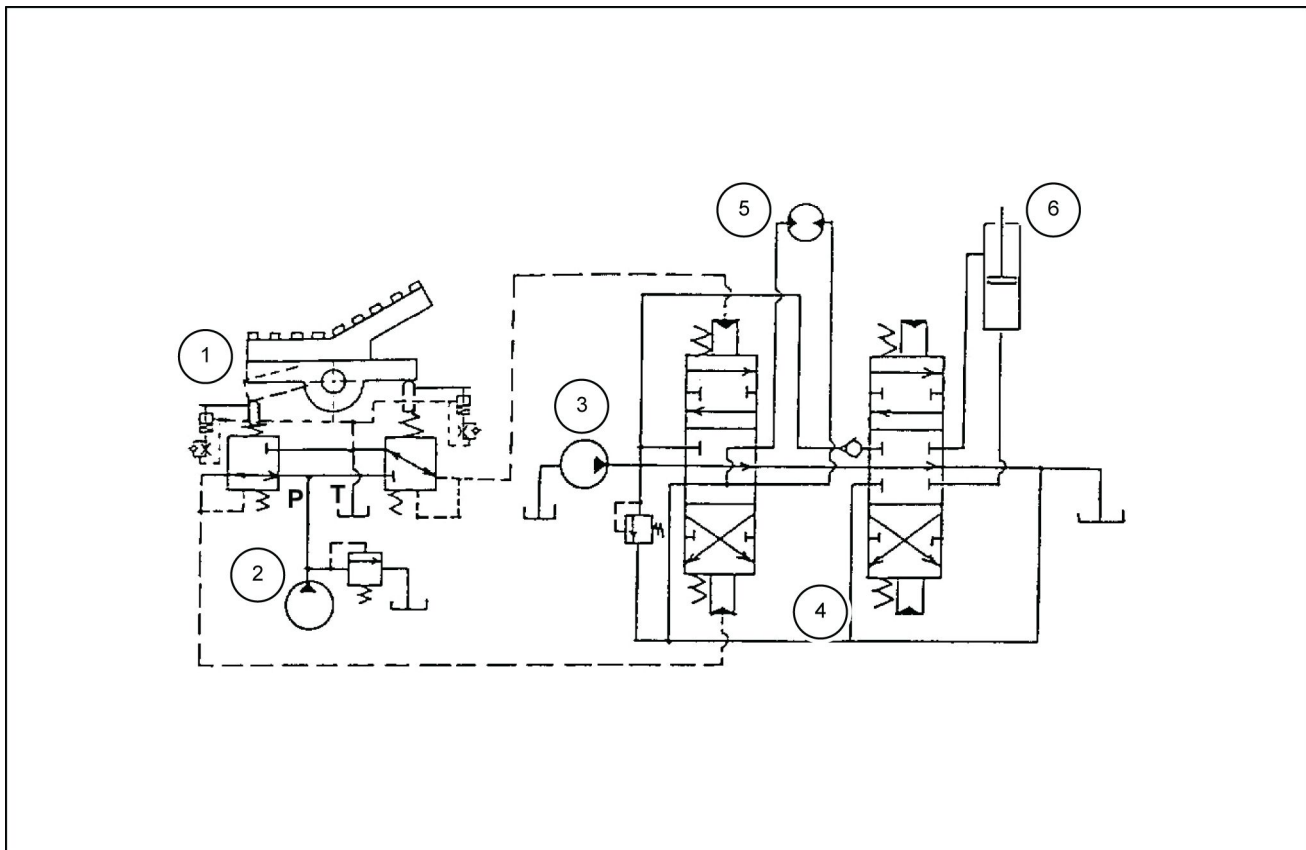

LPIL12CX01998FB 1

- |                         |                       |
|-------------------------|-----------------------|
| 1. Remote control valve | 4. Control valve      |
| 2. Pilot pump           | 5. Hydraulic motor    |
| 3. Main pump            | 6. Hydraulic cylinder |

18. Tighten the hexagon socket head bolts to the specified torque.

- Be careful that the cover is horizontal.
- Hexagon socket head bolt tightening torque:  
**45.2 - 64.8 N·m (33.34 - 47.79 lb ft)**

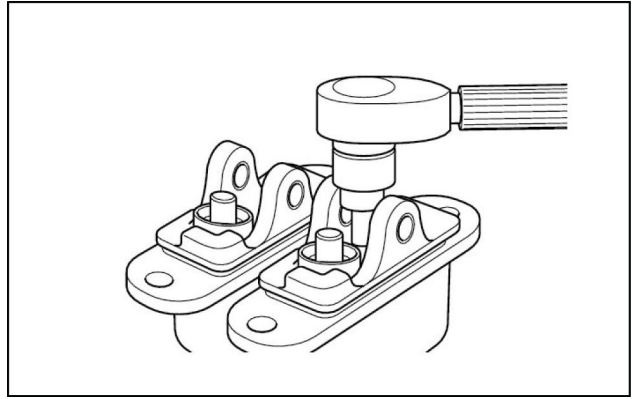

LPIL12CX01871AA 21

19. Temporarily install the locking screws (3) and lock nuts (2) on the cams (1).

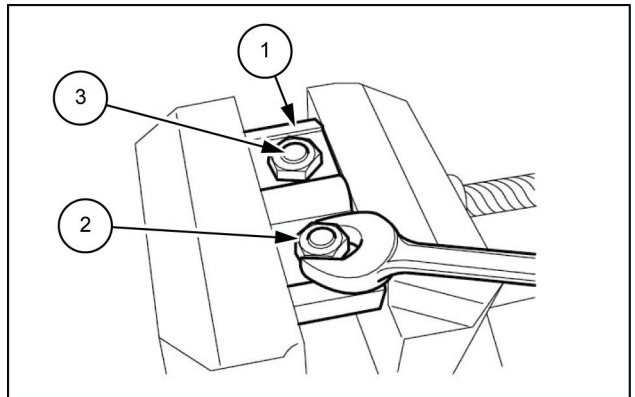

LPIL12CX01872AB 22

20. Install the cams (1) on the covers (2).

- Install them in the positions they were in before disassembly.

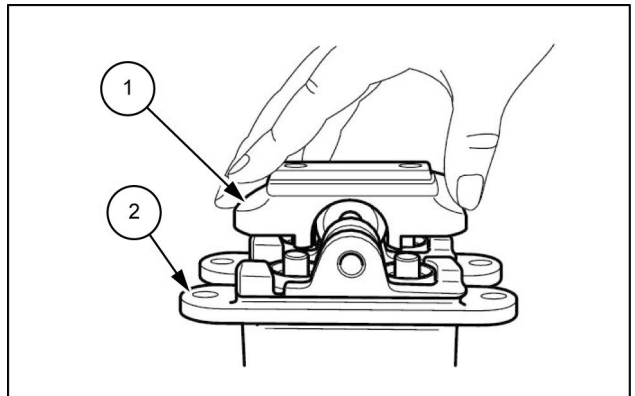

LPIL12CX01873AB 23

21. While holding the cams (1), insert the cam shafts (2) from the outside.

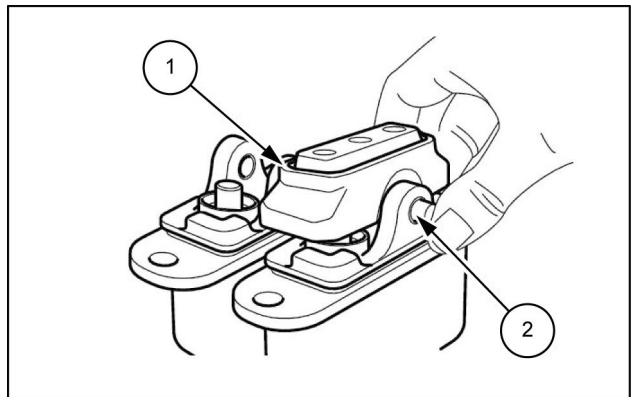

LPIL12CX01874AB 24

in

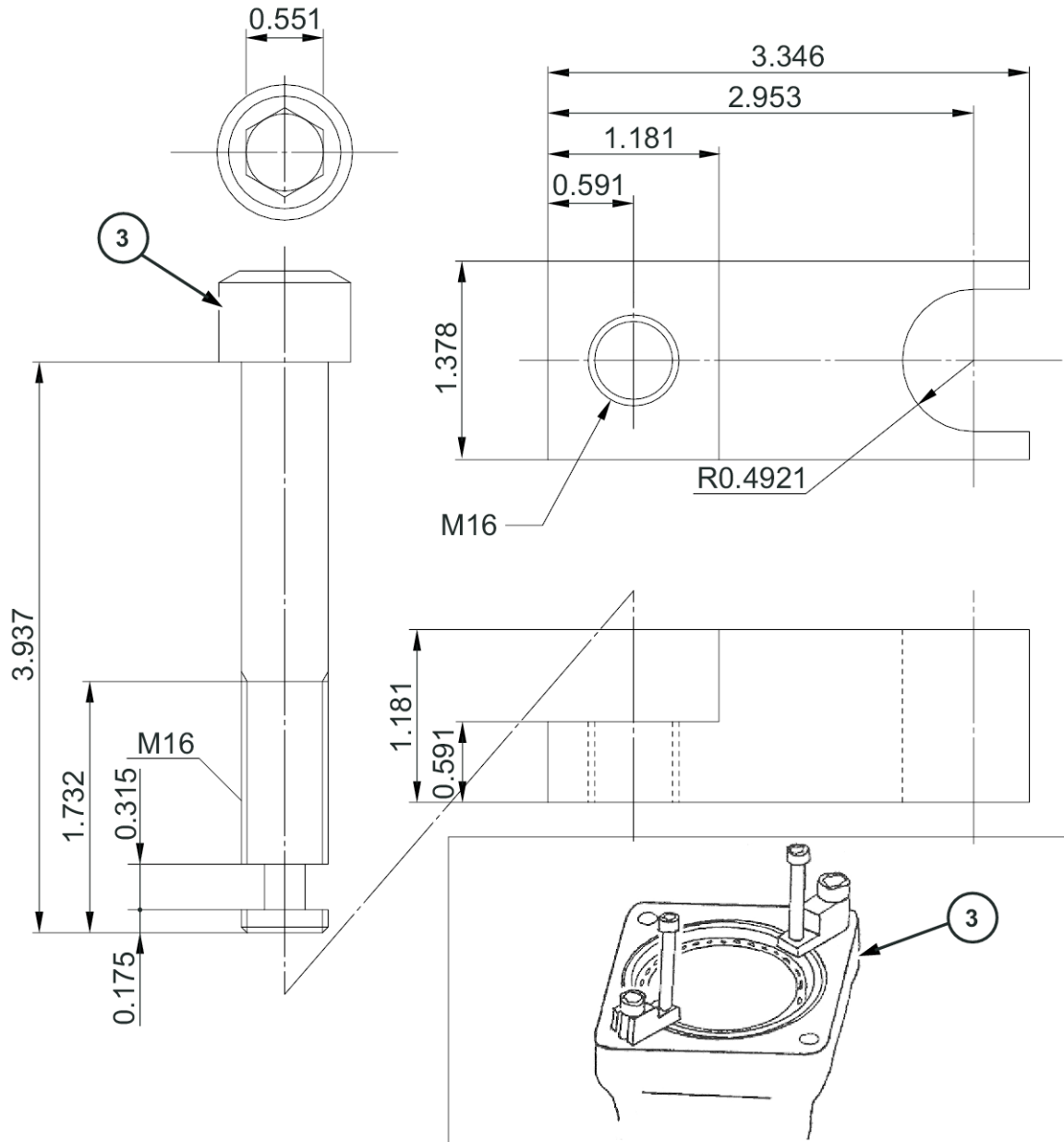

nhdzai-017

NHDZAI-017 2

**NOTE:** all the dimensions in figure are in in.

3 Brake piston removal jig

4. Removal of hose from reduction gear **(5)**.  
Remove the drain hose **(\*2)**.

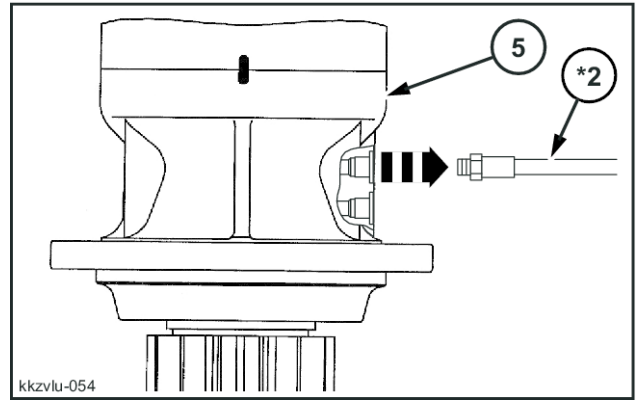

KKZVLU-054 4

5. Removal of motor  
Use the hexagon wrench [ **17 mm**] to loosen and remove the 12 hexagon socket head bolts **(6)**.  
Use the make-up port (G1) to raise the motor and remove it.
- Liquid packing has been applied to the matching surfaces of the housing **(7)** and ring gear **(8)**, so use the notch sections **(\*3)** to remove the motor.

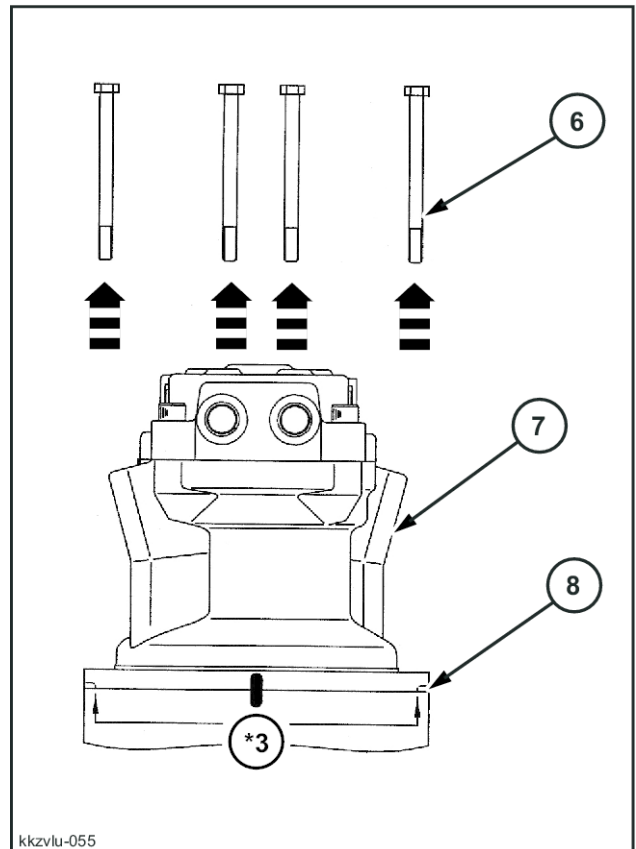

KKZVLU-055 5



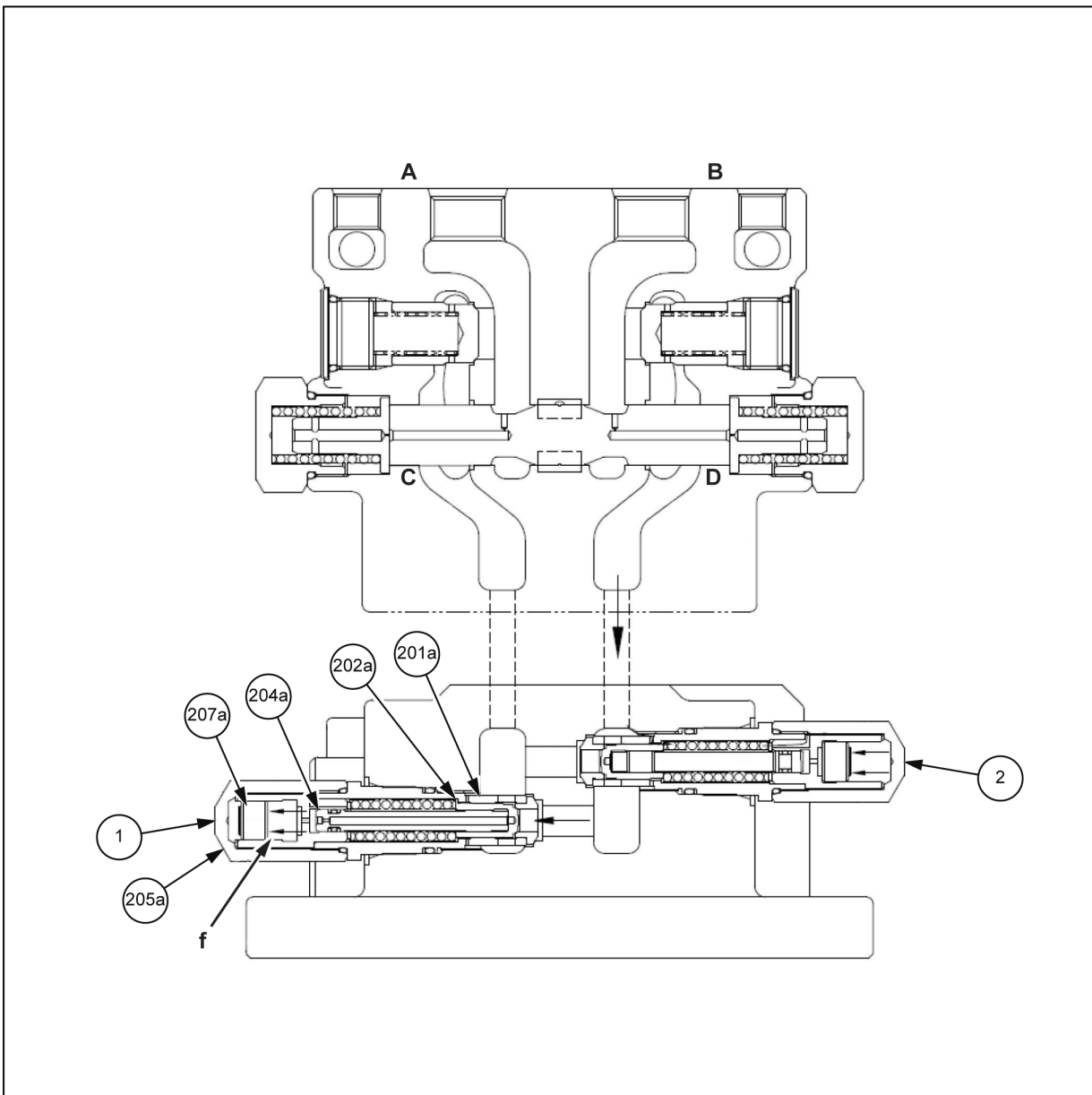

SMIL14CEX3948GB 10

- |       |                |       |             |
|-------|----------------|-------|-------------|
| 1.    | Relief valve A | 204a. | Link piston |
| 2.    | Relief valve B | 205a. | Lid         |
| 201a. | Socket         | 207a. | Piston      |
| 202a. | Valve          |       |             |

3. Remove the valve plate (109) from the rear flange (301).

**NOTICE:** When you remove the valve plate (109), hands may be cut with the edge. Be careful enough.

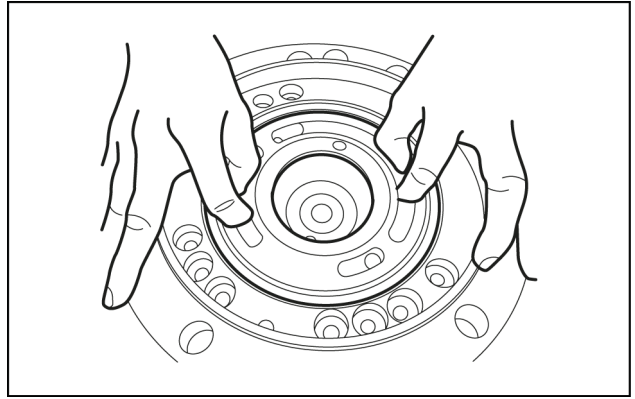

SMIL14CEX3321AA 22

4. Remove the outer ring of conical roller bearing (150) from the rear flange (301).

**NOTE:** There is a shim (119) under the outer ring of conical roller bearing (150). Be careful not to lose it during disassembly.

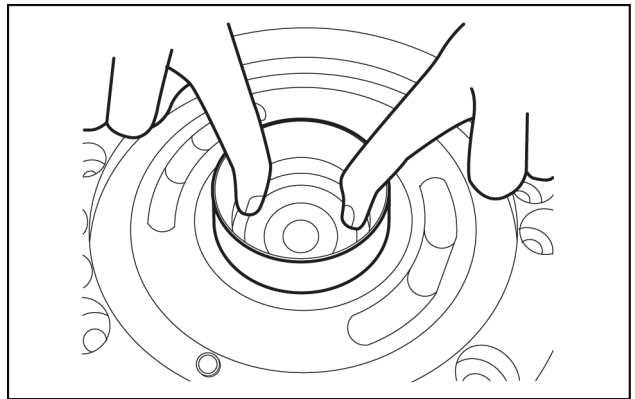

SMIL14CEX3322AA 23

### Disassembly of brake valve components in rear flange

1. Remove the plugs (342) (2 pieces) from the rear flange (301).
2. Remove the O-rings (336) from the plugs (324).

**NOTE:** Do not reuse the removed O-rings (336).

3. Remove each of the 2 springs (328) and spring retainers (325) from the rear flange (301).

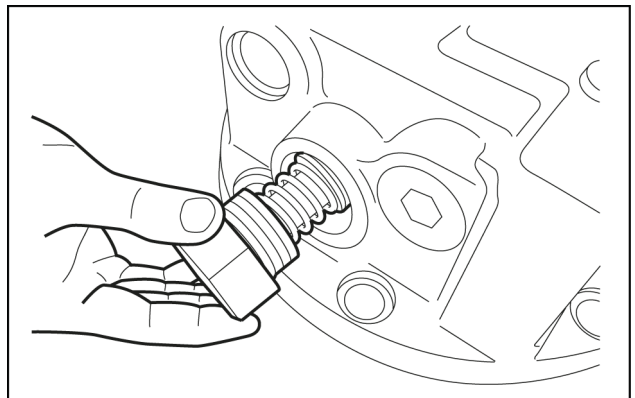

SMIL14CEX3323AA 24

## Travel motor - Service instruction

### Installation instructions

#### **⚠ WARNING**

**Heavy object!**

**ALWAYS** use adequate lifting equipment (heavy-duty hoist, loader, or forklift) to lift the component.

Failure to comply could result in death or serious injury.

W0101A

#### **⚠ WARNING**

**Equipment failure could cause accident or injury!**

Only use rigging equipment that has the capacity to lift the loads that you are moving. Always check the rigging equipment each day for damaged or missing parts. Make sure other workers or bystanders are not under the load while it is moving.

Failure to comply could result in death or serious injury.

W0205A

#### **⚠ WARNING**

**Crushing hazard!**

The lifting systems must be operated by qualified personnel who are aware of the correct procedures to follow. Make sure all lifting equipment is in good condition, and all hooks are equipped with safety latches.

Failure to comply could result in death or serious injury.

W0256A

#### **⚠ WARNING**

**Avoid injury!**

Use Personal Protective Equipment (PPE), including protective goggles, gloves, and safety footwear.

Failure to comply could result in death or serious injury.

W1036A

#### **⚠ CAUTION**

**Crushing hazard!**

If servicing the trips or the floating hoe/shank assemblies, raise the implement depth control system to its limit. Always make sure the long transport safety strut locks are in place. This prevents the implement from dropping uncontrollably in the event of hydraulic failure.

Failure to comply could result in minor or moderate injury.

C0074A

Before installation, unplug the oil check port, and check that lubricant for reduction gear (gear oil) is filled up to the oil check port.

**NOTICE:** When lifting the travel motor, it should be raised perpendicularly in a balanced manner. If being out of balance, it may drop to cause injury.

## Hydraulic swivel - Assemble

1. Place parts in a rough cleaning container filled with kerosene to clean off any adhered matter that can form sharp points and cause scratches.
  - Immerse in kerosene until dust, grease, and other adhered matter comes off and floats to the surface.

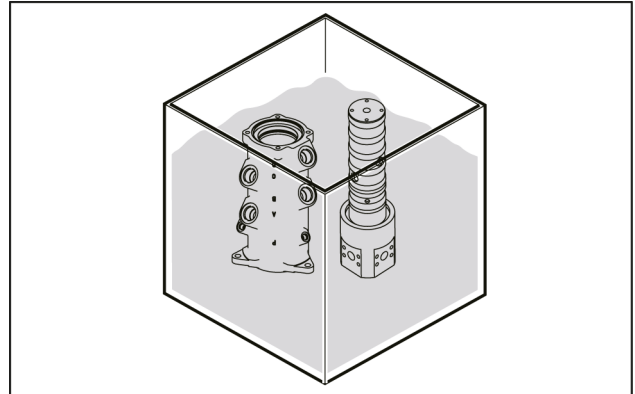

SMIL14CEX1358AA 1

2. Place parts in a finish cleaning container filled with kerosene and clean while gently moving the parts.

After cleaning, wipe away the kerosene with a clean rag.

- Place the parts in a location free of dust and moisture and use compressed air to dry the parts. After drying, coat parts with engine oil.
- Polish away burrs, barbs, and scratches with a whetstone.

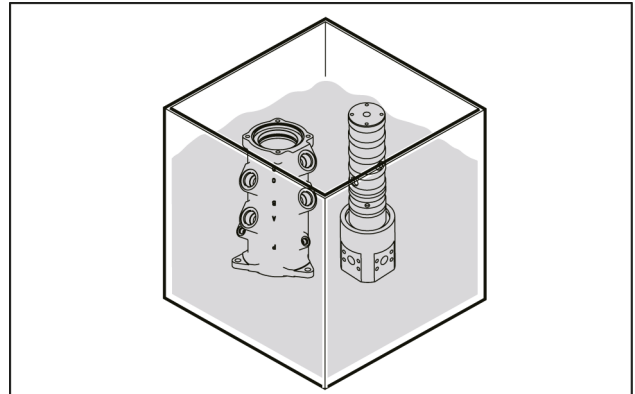

SMIL14CEX1359AA 2

3. Use cleaning fluid or compressed air to clean the rotor (3).

After cleaning, check inside the rotor and in the groove sections for burrs, barbs and scratches and for scratches caused by striking.

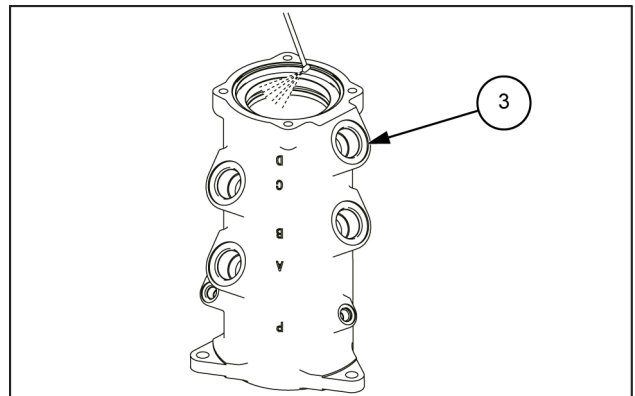

SMIL14CEX1360AB 3

## Usage cautions

- Use under the determined conditions.

### CAUTION:

Use of hydraulic oil other than that specified can cause rapid deterioration of and damage to seal parts. If the relief valve is set to a value higher than that on the assembly diagram, there is a danger of this leading to cylinder damage.

General sealing materials cannot handle high ambient temperature [about **100 °C (212.0 °F)** or higher ] or low ambient temperature [ **-20 °C (-4.0 °F)** or lower], so the cylinder would be damaged if used at such temperatures.

Such temperatures require special seal materials, so check if the cylinder being used complies with this requirement.

The number one cause of cylinder trouble is oil leaks due to piston rod scratches.

Operate very carefully to avoid scratching.

If the piston rod is scratched, handle this according to "Trouble Diagnostics".

- Warm up the equipment adequately before work.

### CAUTION:

After the cylinder has been stopped for a long time, the seal parts inside the cylinder are stuck to the metal of sliding surfaces, so do not suddenly pressurize or operate such a cylinder.

A new cylinder or one that has been left unused for a long time has much air built up inside, so it does not operate smoothly.

Also, if the cylinder is suddenly operated or pressurized without bleeding out the air, the adiabatic compression of the air generates high temperatures, which may burn and carbonize seal parts, leading to a drastically reduced functionality.

Before starting work, always warm up the cylinder by moving slowly through a few full strokes under no load to bleed off any air in the cylinder.

- For stopping the machine temporarily or storing it, always have the machine in a safely secure posture.

### CAUTION:

When extended, the cylinder cannot hold a load for a long time in a fixed position.

This is because the cylinder is extended and retracted by very minor oil leaks from hydraulic circuits and from inside the cylinder and changes in the volume of the hydraulic oil due to oil temperature variation.

This results in the danger of machine moving unexpectedly, which can lead to serious accidents.

For stopping the machine temporarily or storing it, always have the machine in a safely secure position.

## Boom cylinder - Troubleshooting

**NOTICE:** The hydraulic oil expands and contracts with changes in temperature and pressure. This causes the cylinder to extend and retract too, so it can be mistaken for an internal oil leak. For internal oil leaks, always check the temperature and pressure under the same conditions.

Problem	Possible Cause	Correction
<b>Piston rod sliding section oil leak</b>	Piston rod: A sliding surface has rust and scratches that catch on a fingernail	<ul style="list-style-type: none"> <li>Remove the scratches with a whetstone to make the sliding surface smooth ( <b>1.5 s</b> max.). If the oil leak continues, the rod scratches may have damaged the U-ring or other seal, so disassemble and inspect</li> <li>If the scratches or rust cover too large an area to be repaired with a whetstone, replace the piston rod and the U-ring, wiper ring, or other seal and the piston rod bearing part</li> </ul>
	Piston rod: Plating is peeling off	<ul style="list-style-type: none"> <li>Replate or replace the piston rod</li> <li>At this time, inspect the seals and piston rod bearing part as well and replace any that are damaged</li> </ul>
	Rod packing (Buffer ring and U-ring): There is foreign matter caught in the inner or outer diameter section	<ul style="list-style-type: none"> <li>Remove the foreign matter</li> <li>If the packing is damaged, replace it</li> </ul>
	Rod packing (Buffer ring and U-ring): There are scratches on the inner or outer diameter section	Replace
	Rod packing (Buffer ring and U-ring): The lips and groove section are locally carbonized (scorched)	<ul style="list-style-type: none"> <li>This may be scorching due to adiabatic compression of air remaining in the cylinder</li> <li>When operating the cylinder for the first time after replacing a packing, run at low pressure and low speed to adequately bleed off the air</li> </ul>
	Rod packing (Buffer ring and U-ring): The packing has lost its rubber elasticity and is in tatters	<ul style="list-style-type: none"> <li>Replace</li> <li>This may be the end of the packing service life, deterioration of the hydraulic oil, or high temperature of the hydraulic oil                             <ol style="list-style-type: none"> <li>Replace with a new hydraulic oil</li> <li>Check the temperature of the hydraulic oil. (The oil temperature should be no higher than <b>80 °C (176.0 °F)</b>.)</li> <li>Check for local high temperature</li> </ol> </li> </ul>
	Rod packing (Buffer ring and U-ring): The lip section is defective all the way around	<ul style="list-style-type: none"> <li>Replace</li> <li>This may be the end of the packing service life, deterioration of the hydraulic oil, or high temperature of the hydraulic oil                             <ol style="list-style-type: none"> <li>Replace with a new hydraulic oil</li> <li>Check the temperature of the hydraulic oil. (The oil temperature should be no higher than <b>80 °C (176.0 °F)</b>.)</li> <li>Check for local high temperature</li> </ol> </li> </ul>

# Index

---

## Hydraulic systems - 35

### Excavator and backhoe bucket hydraulic system - 738

Bucket cylinder - Install .....	10
Bucket cylinder - Prepare .....	5
Bucket cylinder - Remove .....	6
Bucket cylinder - Sectional view .....	3

CLICK HERE TO **DOWNLOAD** THE COMPLETE MANUAL

- Thank you very much for reading the preview of the manual.
- You can download the complete manual from: [www.heydownloads.com](http://www.heydownloads.com) by clicking the link below



- Please note: If there is no response to CLICKING the link, please download this PDF first and then click on it.

CLICK HERE TO **DOWNLOAD** THE COMPLETE MANUAL

# Index

---

## Tracks and track suspension - 48

### Track frame and driving wheels - 130

Driving wheel - Dimension .....	4
Driving wheel - Install .....	7
Driving wheel - Prepare .....	5
Driving wheel - Remove .....	6
Driving wheel - Service limits .....	3

## Track tensioner - Disassemble

1. Clean the grease cylinder with kerosene, remove the bolt (1) and washer (2), and remove the bracket (3). Remove the check valve (5) from the grease cylinder (4).

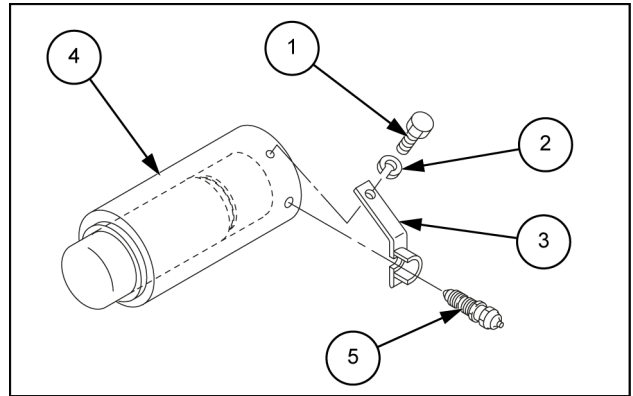

SMIL14CEX1161AB 1

2. Pull out the piston rod (2) from the grease cylinder (1).

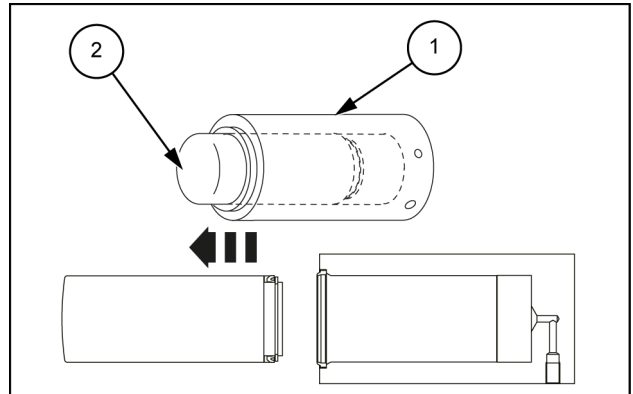

SMIL14CEX1162AB 2

3. Use the removal jig (B) to remove the dust seal (2) from the grease cylinder (1).

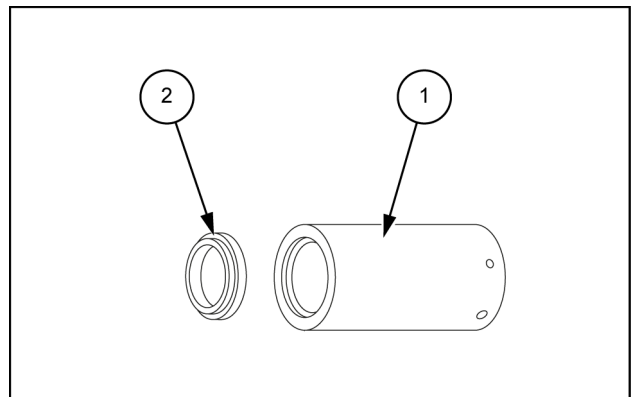

SMIL14CEX1163AB 3

4. Remove the snap ring (2) from the piston rod (1), and then use the removal jig (B) to remove the U-packing (3).

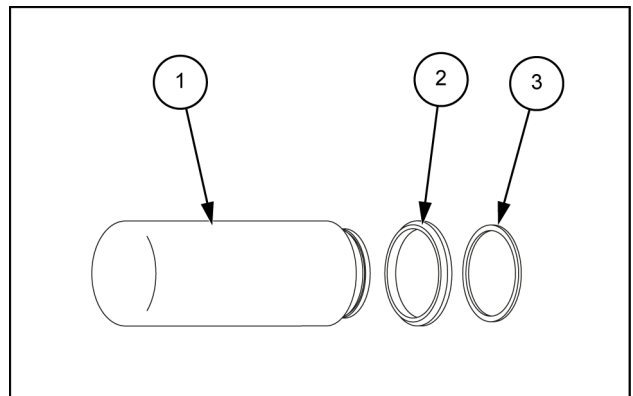

SMIL14CEX1164AB 4

9. Remove the shaft (1).

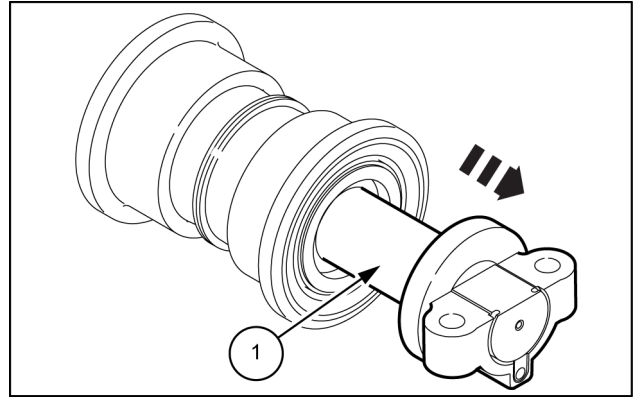

SMIL14CEX1294AB 9

10. Check whether the sliding surface of the floating seal (2) against the removed collar (1) on the opposite side has rusted or is damaged.

Also make sure the O-ring (3) on the seal ring (4) is not twisted.

- The O-ring cannot be reused. Replace it with new part.

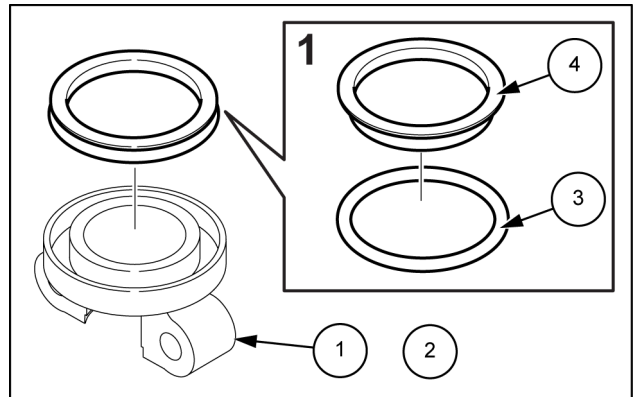

SMIL14CEX1291AB 10

11. As described in Steps 6 and 7, remove the floating seal (1) on the opposite side.

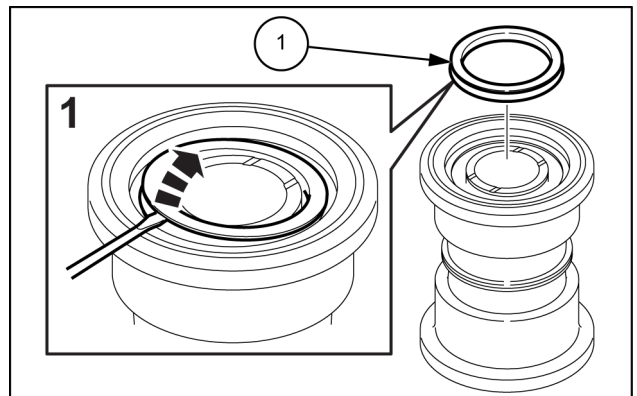

SMIL14CEX1295AB 11

# Contents

---

## Cab climate control - 50

### Air conditioning - 200

#### TECHNICAL DATA

Air conditioning	
Special tools .....	3

#### FUNCTIONAL DATA

Air conditioning	
Overview - Frame .....	4
Overview – Cab .....	7
Overview – Equipment layout diagram .....	10

#### SERVICE

Air conditioning	
Service instruction - Work precautions .....	12
Service instruction - Work procedures .....	14
Filling .....	17
Air-conditioning compressor	
Prepare .....	23
Remove .....	24
Install .....	25
Air-conditioning condenser	
Prepare .....	26
Remove .....	27
Install .....	29
Receiver-dryer	
Prepare .....	30
Remove .....	31
Install .....	33
Air-conditioning evaporator	
Replace .....	34

5. Use a wrench [ **13 mm**] to remove the 2 bolt **(1)**, and then remove the receiver dryer **(2)**.

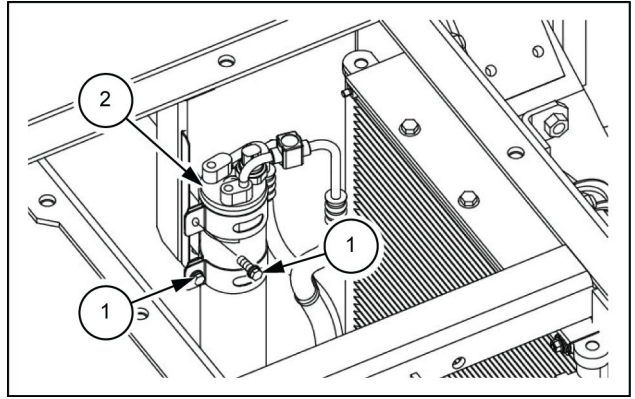

SMIL13CEX3410AB 5

### Starter motor

Model: **5.0 kW - 24 V**

Isuzu part No.: 898060-8540

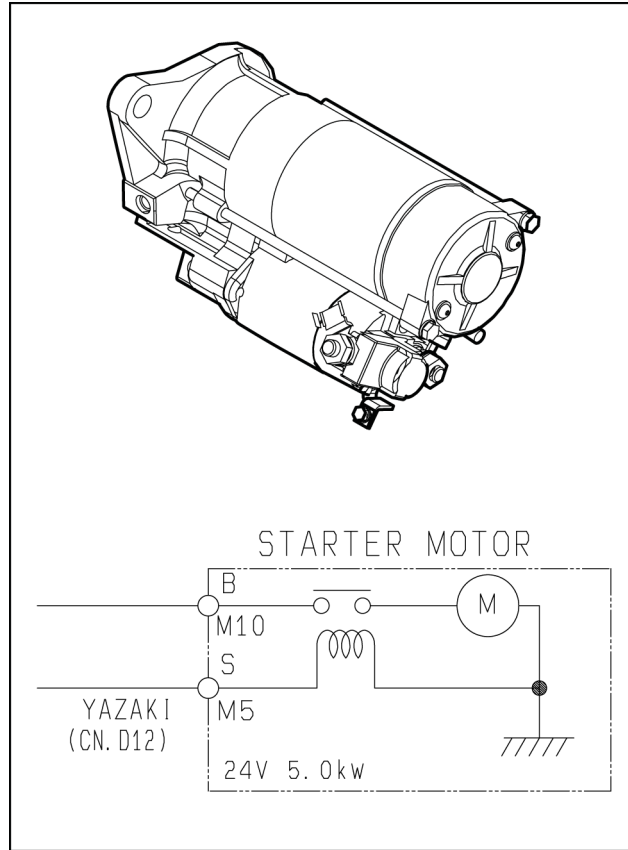

SMIL15CEX3719BA 3

### Alternator

Model: **50 A - 24 V**

Isuzu part No.: 897375-0171

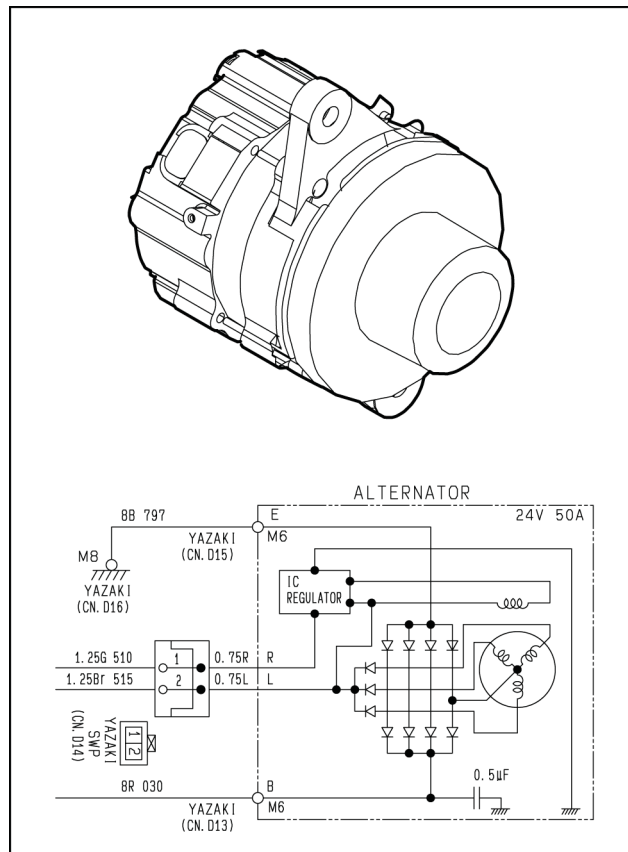

SMIL15CEX3718BA 4

**Receiver dryer (switch)**

Part No.: KHR13590

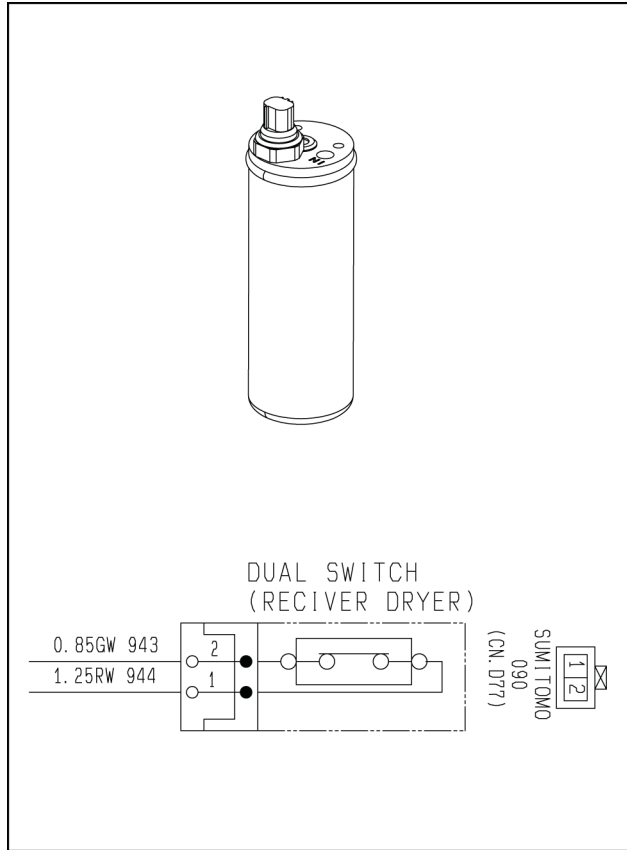

SMIL15CEX4901BA 63

**Air-conditioner compressor (magnetic clutch)**

Part No.: KHR3197

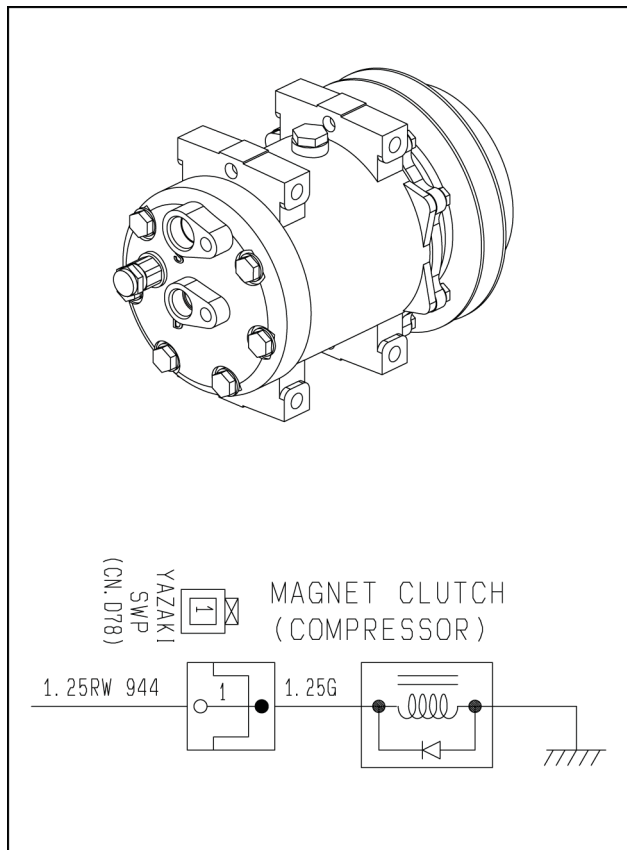

SMIL15CEX4902BA 64









**Wiring harnesses - Electrical schematic sheet 05 – Engine controller**

Type	Components	Connectors/link	Description
Controller	A2		Engine controller
Connector	CN.D1-2	<b>CN.D1-02</b>	Engine controller
Connector	CN.A53	<b>CN.A53</b>	

**Wiring harnesses - Electrical schematic sheet 20 – Option circuit solenoid type**

Type	Components	Connectors/link	Description
Controller	A1		Controller A
Connector	CN.A3	<b>CN.A3</b>	Controller A
Connector	CN.A4	<b>CN.A4</b>	Controller A
Connector	CN.A23	<b>CN.A23</b>	To controller C
Connector	CN.A25	<b>CN.A25</b>	EST connector B
Connector	CN.A44	<b>CN.A44</b>	
Connector	CN.A54	<b>CN.A54</b>	
Connector	CN.A55	<b>CN.A55</b>	
Connector	CN.A56	<b>CN.A56</b>	

**Wiring harnesses - Electrical schematic sheet 35 – Console inter connector**

Type	Components	Connectors/link	Description
Connector	CN.A48	<b>CN.A48</b>	

**CONNECTOR CN.B3 - LIMIT SWITCH (GATE) (Male)**

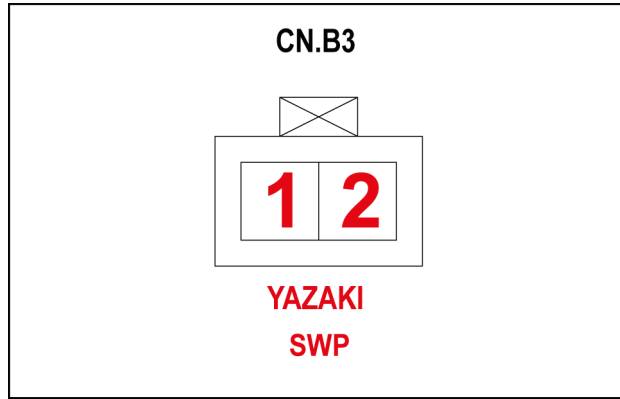

SMIL15CEX3927AA 23

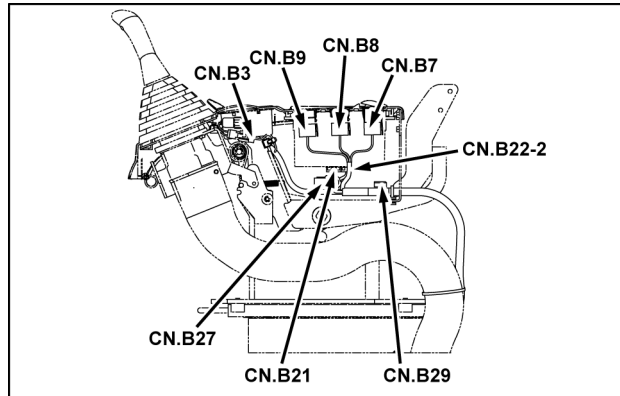

Pin	From	Wire	Description	Color-Size	Frame
1	CN.A46-M-P-3	170A		VW-0.85	<b>SHEET 32</b>
2	SP-840C-P-X	840D		RY-0.85	

**CONNECTOR CN.E7 - OIL PRESSURE SENSOR (Male)**

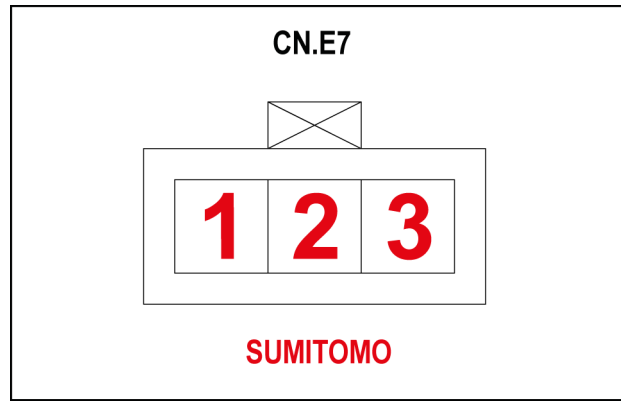

SMIL15CEX4026AA 64

Pin	From	Wire	Description	Color-Size	Frame
1	CN.D7-F-P-9	322A		WB-0.75	<b>SHEET 06</b>
2	CN.D7-F-P-10	323A		LY-0.75	
3	CN.D7-F-P-11	324B		BY-0.75	

**CONNECTOR CN.B18 - PN DIODE (Male)**

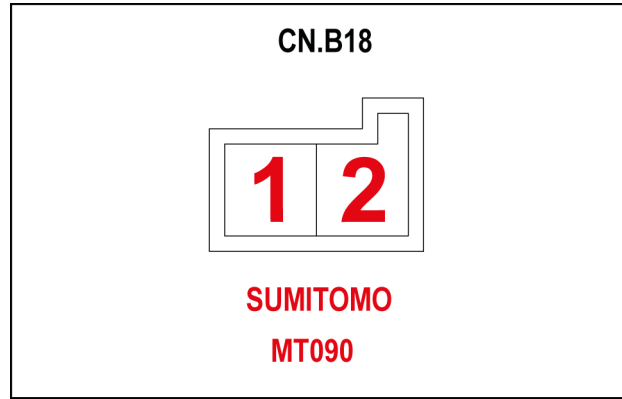

SMIL15CEX3934AA 34

Pin	From	Wire	Description	Color-Size	Frame
1	SP-221C-P-X	222		YR-0.85	<b>SHEET 34</b>
2	SP-720G-P-X	721		B-0.85	

**CONNECTOR CN.E12 - CAM ANGLE SENSOR (Male)**

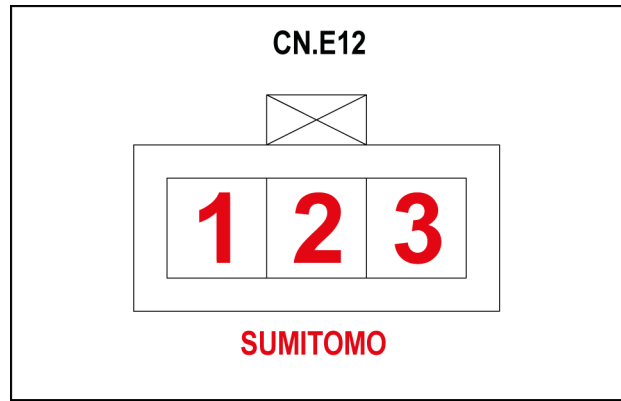

SMIL15CEX4028AA 66

Pin	From	Wire	Description	Color-Size	Frame
1	CN.D7-M-P-19	316B		Y-0.75	<b>SHEET 06</b>
2	CN.D7-M-P-18	318B		OB-0.75	
3	CN.D7-M-P-5	317A		T-0.75	

**CONNECTOR CN.B21 - AIR CONDITIONER SWITCH PANEL (Male)**

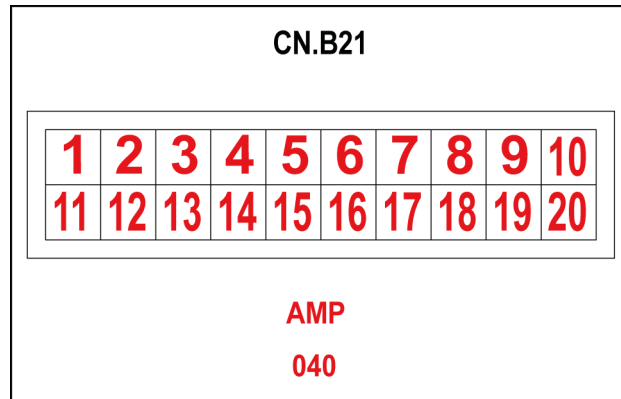

SMIL15CEX4043AA 29

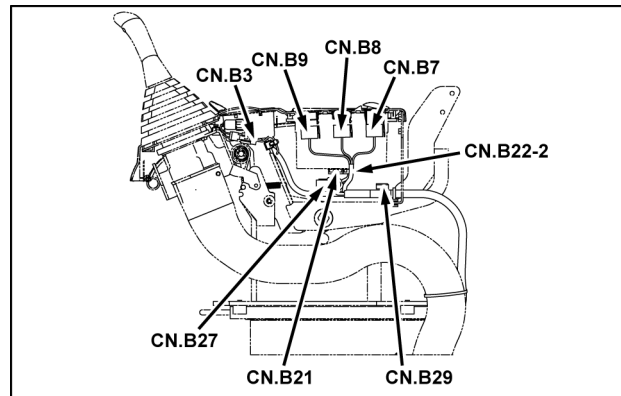

SMIL15CEX3926AA 30

Pin	From	Wire	Description	Color-Size	Frame
1	SP-230-P-X	231		VR	<b>SHEET 37</b>
2	CN.B20-M-P-16	925		LW	<b>SHEET 38</b>
3	CN.B20-M-P-15	924		LR	
4	CN.B20-M-P-14	923		YW	
5	CN.B20-M-P-13	922		YR	
6	CN.B20-M-P-12	921		GW	
7	CN.B20-M-P-11	920		GR	
11	SP-730-P-X	731		B	<b>SHEET 37</b>
12	SP-946-P-X	946		BW	<b>SHEET 36</b>
13	CN.B20-M-P-22	932		BL	<b>SHEET 38</b>
15	CN.B20-M-P-18	926		LY	
16	CN.A48-M-P-12	949C		WB	<b>SHEET 35</b>
18	CN.B20-M-P-9	947		L	<b>SHEET 37</b>
19	CN.B20-M-P-8	945		Sb	

**CONNECTOR CN.D28 - RELAY STARTER (Male)**

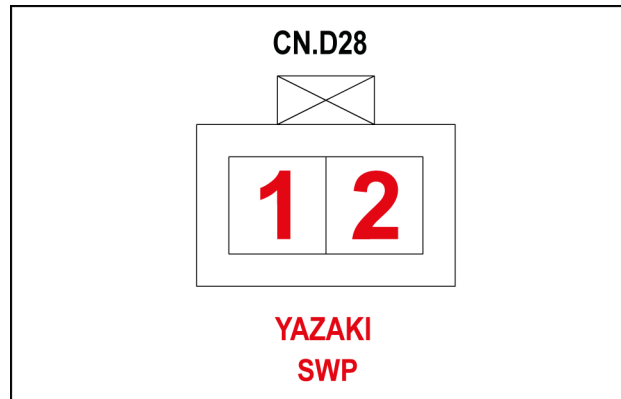

SMIL15CEX3989AA 63

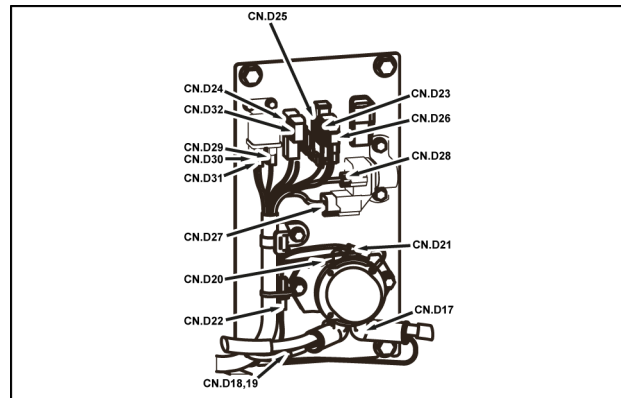

SMIL15CEX7245AA 64

Pin	From	Wire	Description	Color-Size	Frame
1	SP-012-P-X	012		GrR-0.85	SHEET 01
2	SP-750-P-X	750		B-0.85	

**CONNECTOR CN.A41 (Male)**

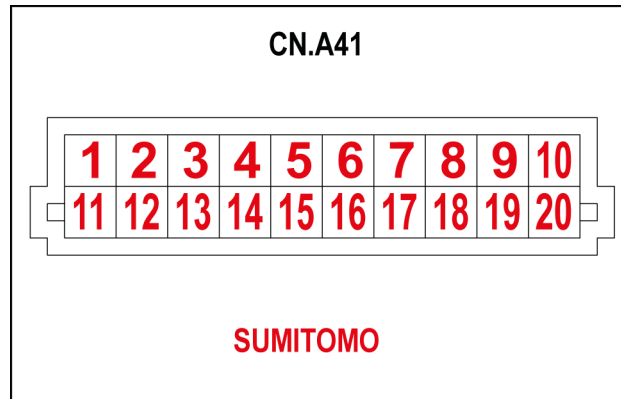

SMIL15CEX3893AA 3

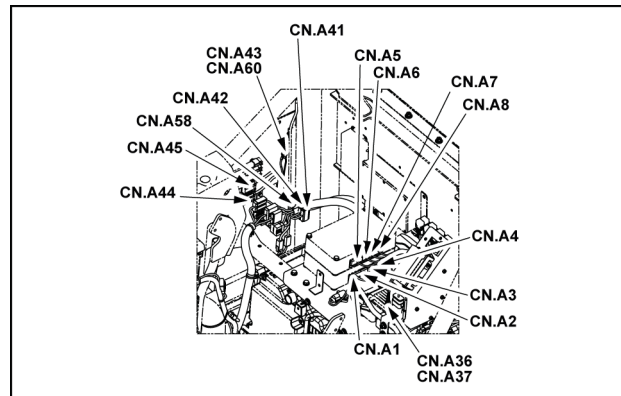

SMIL15CEX3855AA 4

Pin	From	Wire	Description	Color-Size	Frame
1	CN.A53-F-P-7	040A		P	<b>SHEET 24</b>
2	CN.A44-M-P-7	040B		P	<b>SHEET 25</b>
3	CN.A2-P-6	040C		P	<b>SHEET 21</b>
4	CN.A6-P-6	040D		P	<b>SHEET 22</b>
5	CN.A23-P-7	040E		P	<b>SHEET 20</b>
6	CN.A24-M-P-7	040F		P	<b>SHEET 28</b>
7	CN.A48-F-P-10	040G		P	<b>SHEET 35</b>
8	CN.A26-M-P-3	040H		P	<b>SHEET 28</b>
9	CN.A27-M-P-3	040R		P	
10	CN.A34F-P-1	040J		P	
11	F4-P-IN	160		RL	<b>SHEET 03</b>
12	CN.A44-M-P-1	161B		RL	<b>SHEET 25</b>
13	CN.A49-F-P-1	162		RL	<b>SHEET 34</b>
14	CN.A28-P-2	163		RL	
15	SP-164-P-X	164		RL	<b>SHEET 24</b>
16	SP-501-P-X	502		G-0.85	<b>SHEET 30</b>
17	CN.A1-P-7	503		G-0.85	<b>SHEET 21</b>
18	CN.A5-P-7	504		G-0.85	<b>SHEET 23</b>
19	CN.A23-P-3	505		G-0.85	<b>SHEET 24</b>
20	SP-506-P-X	506		G-0.85	

**CONNECTOR CN.57-1A - OPTION SELECT SOLENOID VALVE (Male)**

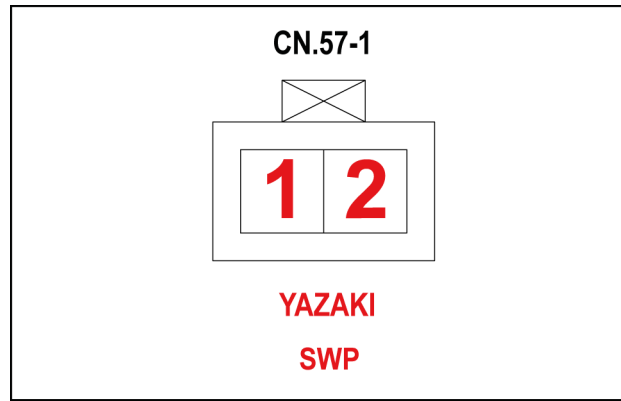

SMIL15CEX4164AA 4

Pin	From	Wire	Description	Color-Size	Frame
1	SP-260H-P-X	260J		WL-0.75	<b>SHEET 19</b>
2	CN.A57-M-P-2	806E		LY-0.75	<b>SHEET 17</b>

**CONNECTOR CN.57-8 - OPTION 2 KNOB (L)-L (Male)**

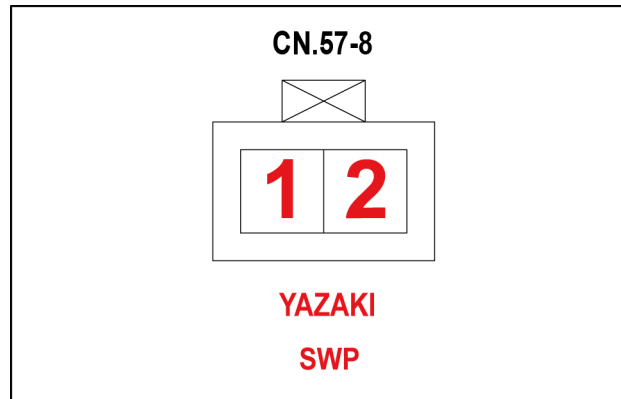

SMIL16CEX0252AA 34

Pin	From	Wire	Description	Color-Size	Frame
1	SP-263A-P-X	265		WL-0.75	<b>SHEET 42</b>
2	SP-856A-P-X	856B		OL-0.75	

**CONNECTOR CN.D50 - PRESSURE SENSOR (PILOT UPPER) (Male)**

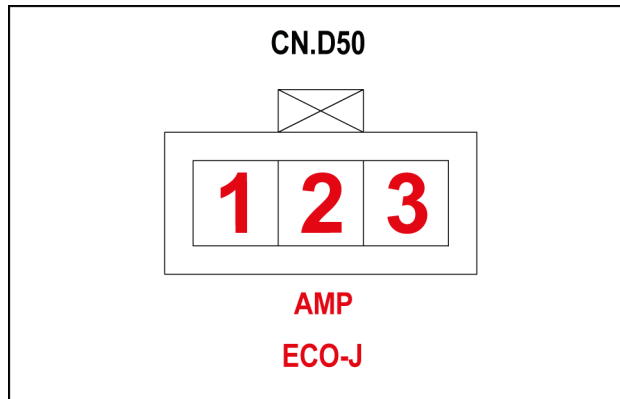

SMIL15CEX3980AA 79

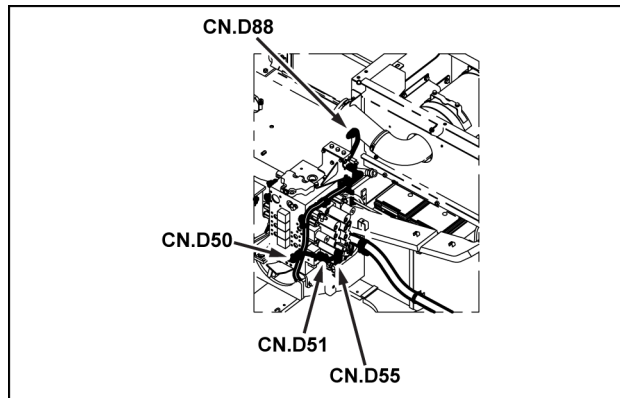

SMIL15CEX7263AA 80

Pin	From	Wire	Description	Color-Size	Frame
1	SP-409D-P-X	405		W-0.85	<b>SHEET 14</b>
2	CN.A54-M-P-8	415A		V-0.85	<b>SHEET 21</b>
3	SP-429D-P-X	425		BW-0.85	<b>SHEET 14</b>

## Wire connectors - Component diagram 07

*CN.D70 - HORN LOW (LEFT) (Male)*

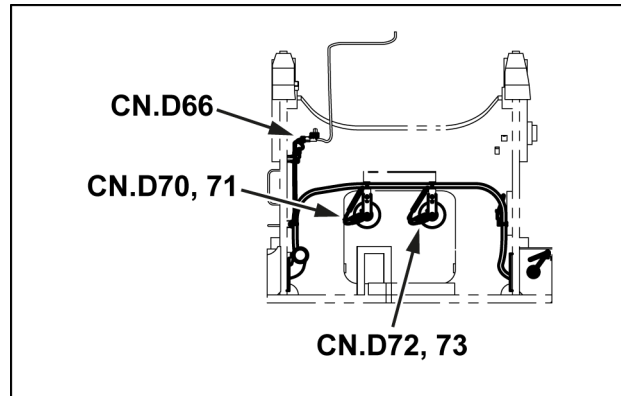

SMIL15CEX7281AA 1

Pin	From	Wire	Description	Color-Size	Frame
1	CN.A55-M-P-10	880A		LR-0.85	<b>SHEET 31</b>

**CONNECTOR CN.D93 - FUEL FILTER LEVEL SWITCH (Male)**

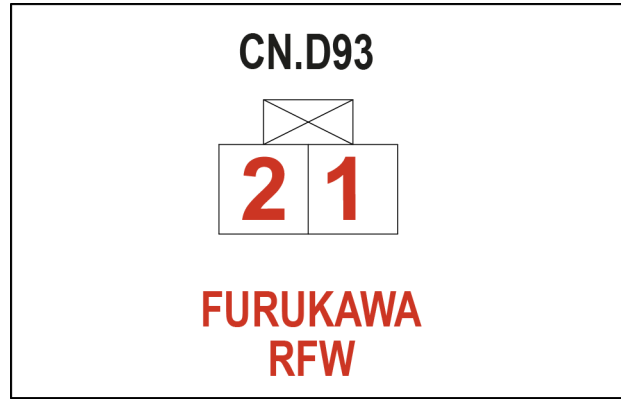

SMIL16CEX0607AA 4

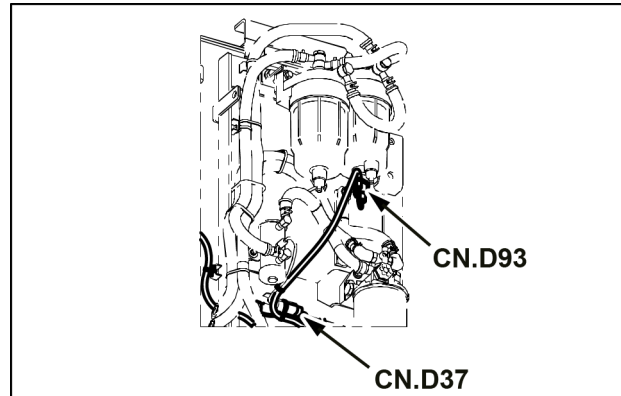

SMIL16CEX0608AA 5

Pin	From	Wire	Description	Color-Size	Frame
1	SP-600D-P-X	654		BG-0.75	<b>SHEET 10</b>
2	CN.A54-M-P-21	546A		WG-0.75	<b>SHEET 21</b>

## Second stage

After the first-stage warning is issued, if the output value from the fuel filter pressure sensor falls below the specified threshold further, a second-stage warning is issued.

The second-stage warning remains in effect until the key switch is turned OFF.

At the same time that the second-stage warning is issued, the engine target speed is gradually reduced at a constant rate.

When the output value from the sensor exceeds the specified threshold, the restricted speed stops being lowered and control continues with the restricted speed in effect at that point.

When the output value from the sensor falls below the threshold value again, the restricted speed is further lowered. When the key switch is turned OFF, then ON again, the restriction is released.

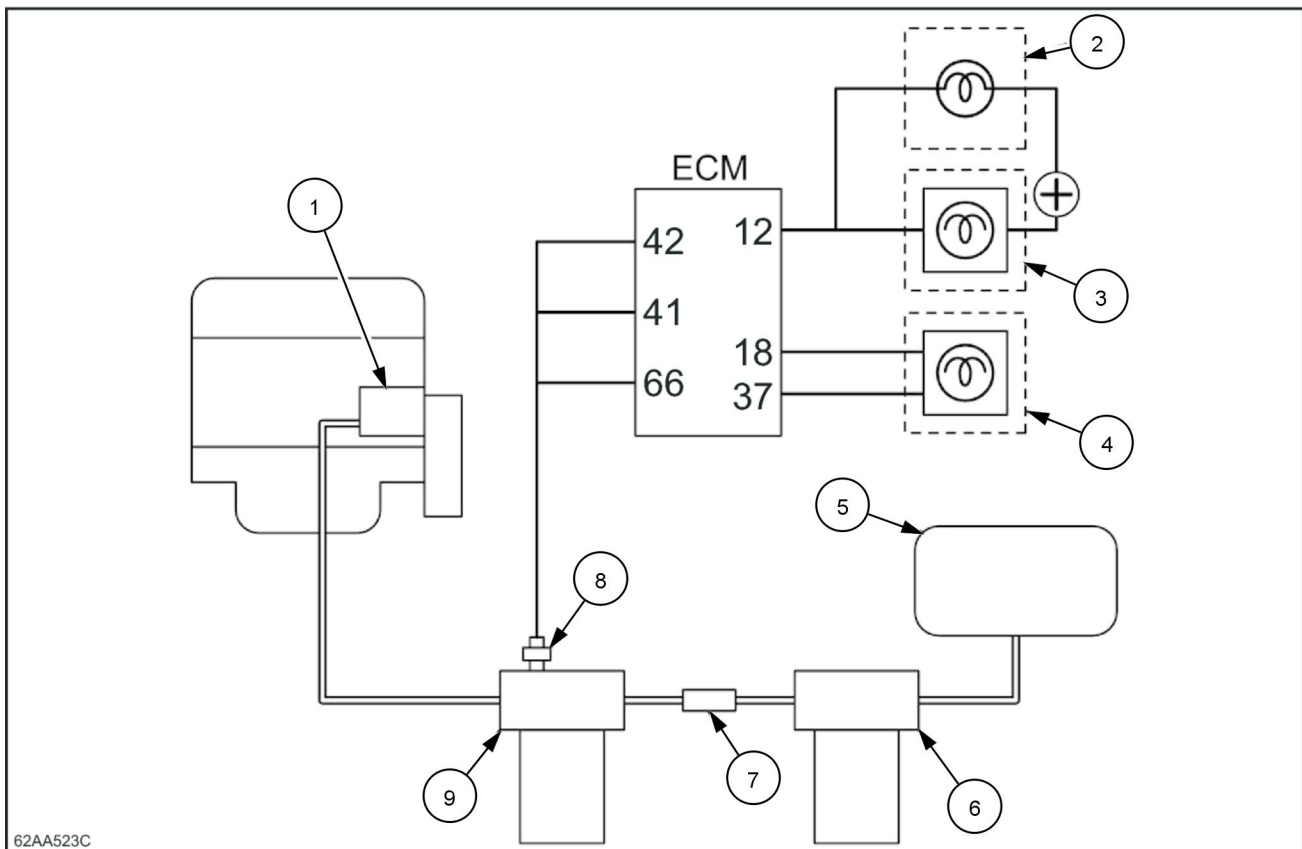

- |                 |                               |                                |
|-----------------|-------------------------------|--------------------------------|
| 1. Supply pump  | 4. Monitor, CAN communication | 7. Charge fuel pump            |
| 2. Warning lamp | 5. Fuel tank                  | 8. Fuel filter pressure sensor |
| 3. Monitor      | 6. Pre-filter                 | 9. Main filter                 |

## Engine Control Unit (ECU) - Prepare

Items to prepare:

- Wrench [ **10 mm**]

2. Determining the cooling operation completion

1. With the engine running at **1250 RPM** or less, at least **3 min** have passed without performing upper, swing, travel, first option, or second option operation.

## Engine starting system - Inspect – Starting system

### Description of function

This diagnosis chart is a systematized approach to grasping the condition causing a state in which the engine does not start.

The appropriate system diagnosis can be performed with this diagnostic chart.

- The battery must be fully charged to perform this diagnosis.
- The battery cables must be securely connected to perform this diagnosis.
- The engine speed during cranking must be normal to perform this diagnosis.
- Appropriate fuel must be supplied adequately to perform this diagnosis.
- There must be no fuel leaks to perform this diagnosis.
- Air must not be mixed in with the fuel to perform this diagnosis.
- The air filter element must be clean to perform this diagnosis.
- The fuel filter must be clean to perform this diagnosis.

### Inspection

1. Inspection performed when the starter operates and cranks the engine, but the engine does not start.

Turn the emergency stop switch "OFF".

Inspect the overheat switch circuit.

A. If a problem is found, repair the circuit.

2. Confirm the diagnostic trouble code.

If a diagnostic trouble code is detected, inspect for the relevant diagnostic trouble code.

Use the trouble diagnosis scan tool to check the display of the SCV F/B while cranking the engine.

Standard value: **900 mA**

If it is below the standard value, repair the SCV-LO drive circuit.

Disconnect the harness connector from the SCV.

Turn the starter switch OFF.

Use the trouble diagnosis scan tool to check the indicated fuel rail pressure while cranking the engine.

3. If the fuel rail pressure does not increase, inspect the suction control valve and circuit.

Inspect the fuel system.

Inspect the fuel pressure sensor.

Inspect the coolant temperature sensor.



## Intake manifold pressure sensor - Inspect

1. Inspect the barometric pressure sensor.
  - Dirt on main unit
  - Damage on main unit
  - Abnormality in terminal section

**NOTICE:** *Do not wash the sensor, as doing so may damage inside of the sensor.*



## Instrument cluster - Dynamic description – Coolant temperature gauge

### Purpose

Displays the coolant temperature using a meter and bar graph. (Coolant temperature check)

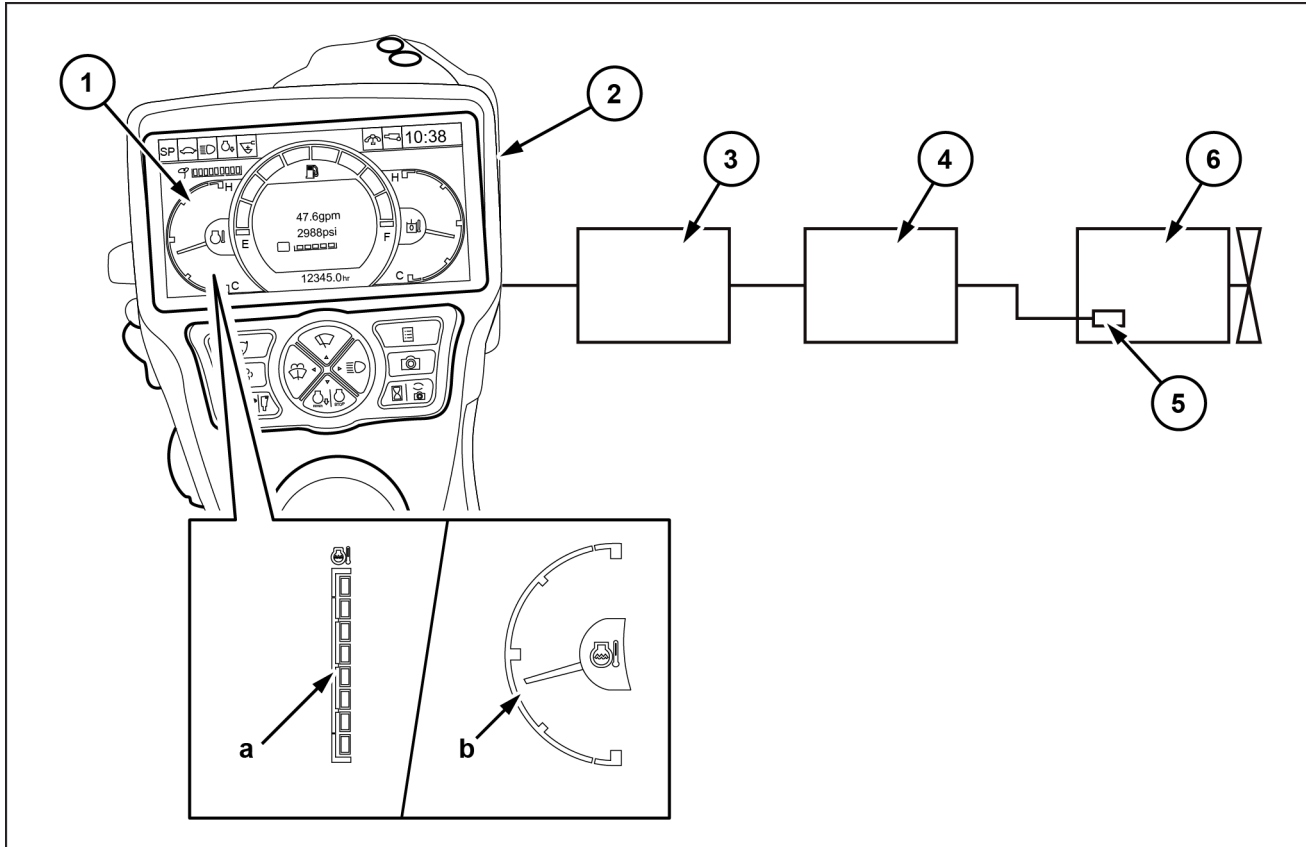

SMIL16CEX0270FB 1

- |                              |                               |
|------------------------------|-------------------------------|
| 1. Coolant temperature gauge | 5. Coolant temperature sensor |
| 2. Monitor                   | 6. Engine                     |
| 3. Computer A                | a. Bar graph display          |
| 4. ECM                       | b. Meter display              |

### Operation explanation

1. When the key is turned "ON", the coolant temperature gauge indicates the position of the coolant temperature range.
2. When the camera screen select switch is pressed to switch to the camera screen, the coolant temperature bar graph is displayed on the left side.
3. The meter and bar graph are not displayed if coolant temperature sensor trouble is detected.

## Instrument cluster - Static description - List of control unit screens

System hardware information is displayed.

By pressing  and  on the monitor, each system can be selected.

Detailed data for the selected item can be seen by pressing .

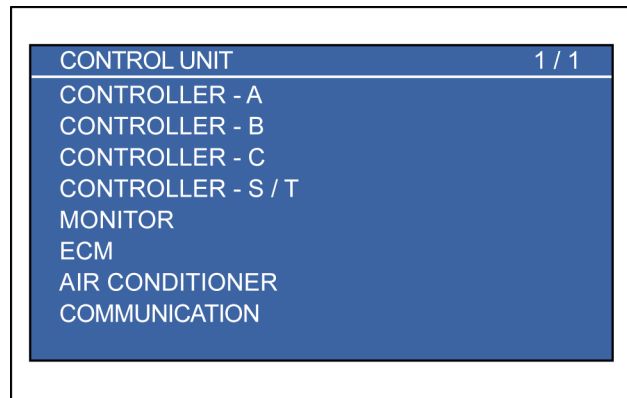

SMIL14CEX0536AA 1

### Controller A

#### Digital In/Out

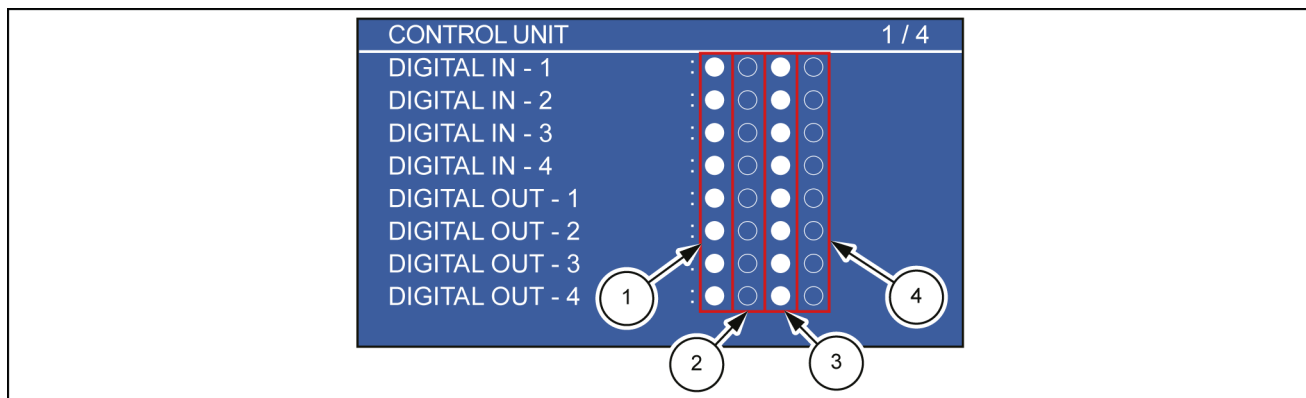

SMIL15CEX4928EB 2

●	ON
○	OFF

DIGITAL IN-1	1	One-touch idle switch
	2	Anti-theft switch
	3	Coolant level switch
	4	Air cleaner switch
DIGITAL IN-2	1	1 <sup>st</sup> option pressure switch
	2	2 <sup>nd</sup> option pressure switch
	3	Free swing switch
	4	HBCV, travel alarm switch
DIGITAL IN-3	1	Hydraulic return filter pressure switch
	2	Engine emergency stop switch
	3	-
	4	Lifting magnet operation switch (lifting magnet model only)
DIGITAL IN-4	1	Lifting magnet mode switch (lifting magnet model only)
	2	Key switch
	3	Gate lever switch
	4	Battery charge

DIGITAL OUT-1	1	Swing brake solenoid
	2	Travel 2-speed switch solenoid
	3	Power boost solenoid
	4	Free swing solenoid (US only)

## Engine service monitor

### Service monitor structure

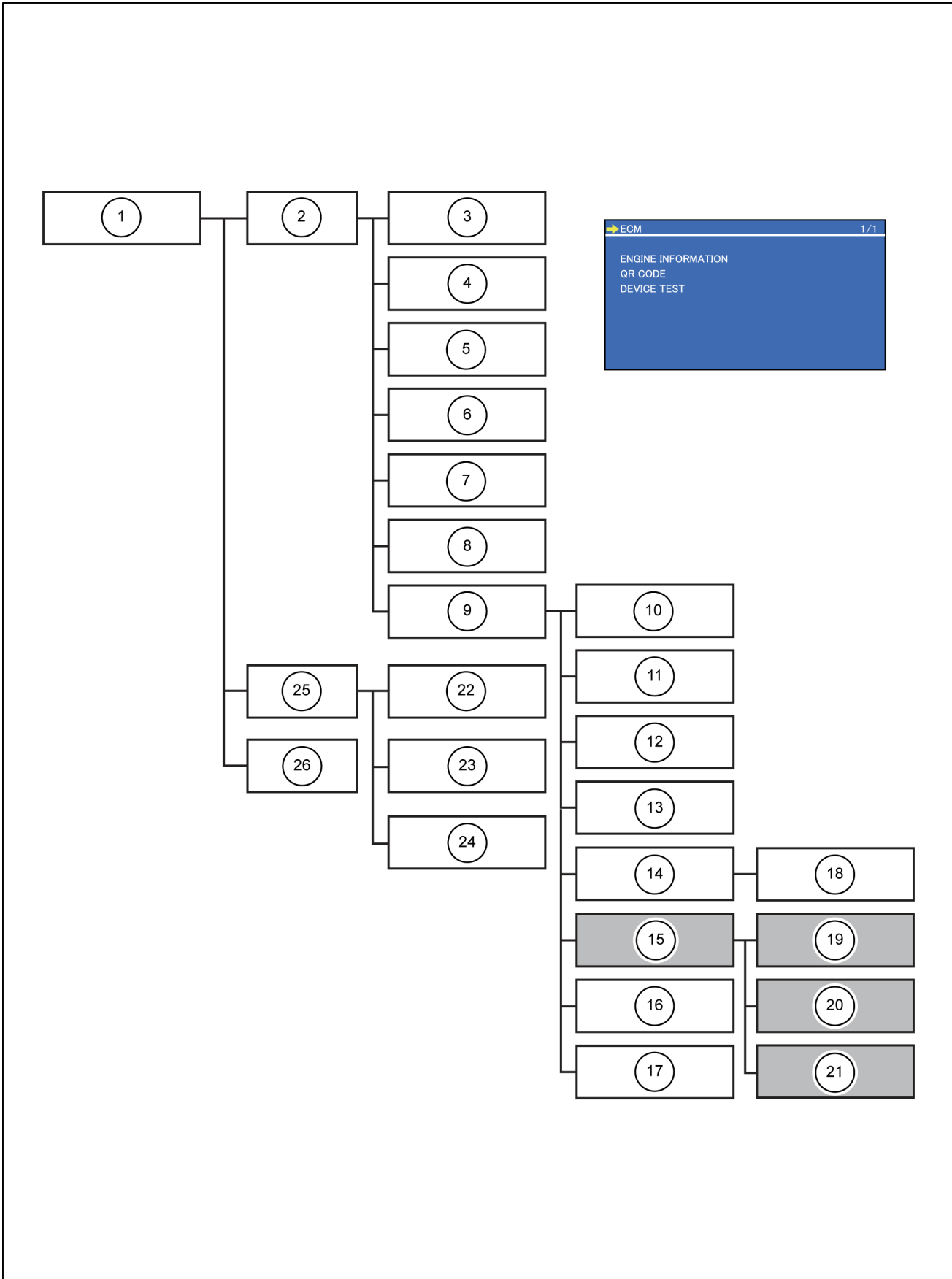

## 2. Option line operation control

The table below shows the control for operation of the independent option and compound operation.

Option line mode	Breaker		Crusher		2nd option	
Operation	1st option pressure switch "ON" (IN3 is ground)		1st option pressure switch "ON" (IN3 is ground)		2nd option pressure switch "ON" (IN4 is ground)	
	Independent	Compound	Independent	Compound	Independent	Compound
Boost cut	Yes		Yes		No	
Flow restriction	Yes		Yes	No	No function (4th pump)	
Engine speed/ milli-amp for pump horsepower control proportional valve	According to the command for the work mode selected with the throttle					

- The flow is not cut for compound crusher operation. (to secure speed for compound operation)
- Since the breaker often works while the machine is jacked up with the boom (compound operation), the flow is cut even for compound work. (the same as the engine reduction for the current breaker)
- The pressure boost is cut when Option 1 and Option 2 are operated at the same time. (boost cut priority)
- The engine speed and milli-amp for pump horsepower control proportional valve are according to the work mode currently selected with the throttle. (cannot be forced to change to another mode only for breaker/crusher. )

## 3. Option 1 independent operation judgment conditions

When all the conditions below are satisfied, it is judged that this is independent operation.  
Conditions

1st option pressure switch "ON"  
Travel pressure sensor "OFF"

Swing pressure sensor "OFF"  
N2 pressure sensor  $\geq 2.4$  MPa (348 psi)

## 4. Flow cut

The maximum flow during option line operation is restricted by the option line selected in "Option line selection and 2 pumps flow".

Also, be careful about the fact that since the flow set for the option line is the flow for SP mode, when used in H/A mode, the flow is slightly less than the display.

When neither the breaker or crusher mode is selected (normal mode), the minimum flow amount [ **50 L/min (13.209 US gpm)** ] is produced when the pedal is pressed. (For prevention of damage to attachments)

## 5. Trouble mode

If a trouble occurs in input (swing pressure sensor, travel pressure sensor, N2 pressure sensor) or output (pressure boost solenoid, flow proportional valve), the machine goes into trouble mode and

- Output command to pressure boost solenoid = fixed to "OFF"
- Output command to flow proportional valve = fixed to "OFF"

Mode continues until the key is switched "OFF".

## Heating, Ventilation, and Air-Conditioning (HVAC) control system - Dynamic description

### Back-up function

Even when air-conditioner operation is stopped (switched OFF) with the vehicle main key power supply or operation panel ON/OFF switch, the set temperature and all the other setting states are stored in memory, so the next time air conditioner operation starts, it goes into the same state as before it was stopped.

When the vehicle main key power supply is cut off, the data is backed up by storing it in the internal EEPROM.

However, if the main key power supply is cut off within **0.5 s** of switch input, that switch input is not stored into memory.

Also, the data read out from EEPROM when the power is switched ON is judged to see if it is within the valid range. If data outside the valid range was written into memory, for example due to noise, then operation starts from the default setting values to avoid abnormal operation.

### Fahrenheit temperature display

To switch, hold down both the temperature setting UP and DOWN switches for **5 s**.

The display toggles between Celsius and Fahrenheit display each time the switches are both held down for **5 s**.

The Fahrenheit display is a 2-digit integer and below the decimal point is not used, so "F" is displayed.

However, in case of trouble, this display takes priority.

When this display is switched, the new status is backed up in memory, so even if the main key power supply is switched OFF, the display status is retained.

Internal calculations are all done in Celsius. Only the operation panel display is in Fahrenheit.

Therefore, the display may differ slightly from the exact Fahrenheit temperature.

### Air mix motor actuator control

#### 1. Summary explanation.

The provisional target degree of opening is determined from the target blow temperature and the current blow mode, various restrictions are applied, and the target degree of opening is calculated.

Then drive is output to move the motor actuator position to the target degree of opening. Below are the details.

#### 2. Heater unit hysteresis correction operation (motor actuator one-direction stop).

After the actuator moves to the target degree of opening, it returns to the specified position. However, if the target degree of opening is less than  $0^\circ$ , the actuator is treated as having reached the target degree of opening when it reaches  $0^\circ$ , then it moves to the specified position. (A stop in the fully-open direction is used as the reference.)

#### 3. Motor actuator operation priority order.

The operation priority for this motor actuator is No. 1.

This means that if the target degree of opening for this motor actuator changes and operation becomes necessary, even if some other motor actuator is operating, that other motor operation is paused, and this motor actuator operates.

#### 4. Motor actuator retry control.

Even when there are no changes to the target values after the target is attained, if the difference between the current value and the target value once every **5 min** is equal to or greater than the operation start angle, the motor actuator is operated.

### Blow mode motor actuator control

#### 1. Summary explanation.

The blow mode is switched by rotating the diffuser switching damper with the motor actuator. There are 2 types of control: auto and manual.

#### 2. Auto control.

## Swing control system - Dynamic description – Swing relief cut

### Purpose

When independent swing operation is running, the pump flow is reduced, and the excess oil ejected from the swing motor relief valve is eliminated.

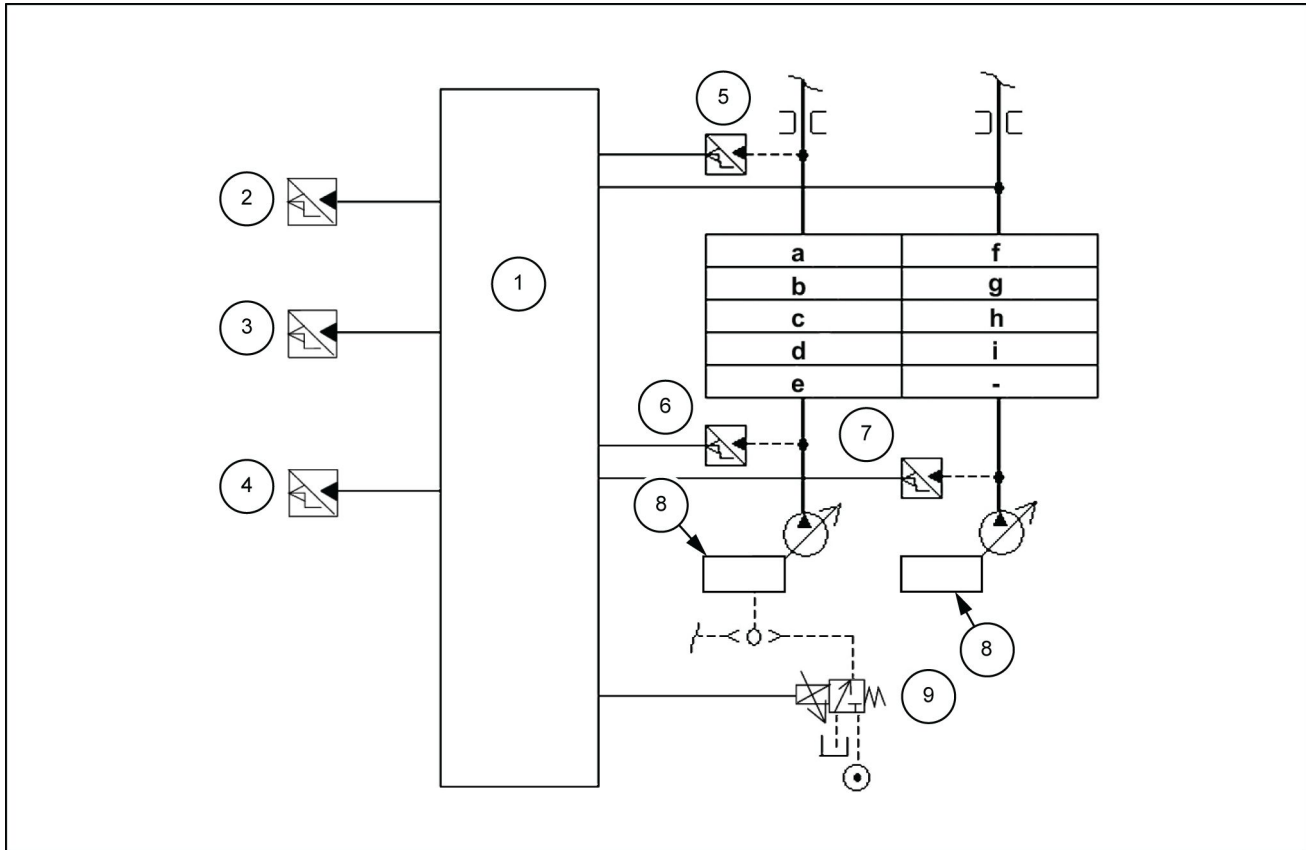

LPIL12CX01016FB 1

- |                               |                                       |
|-------------------------------|---------------------------------------|
| 1. Computer A                 | 6. Pressure sensor (P1)               |
| 2. Oil temperature sensor     | 7. Pressure sensor (P2)               |
| 3. Pressure sensor (travel)   | 8. Regulator                          |
| 4. Pressure sensor (option 1) | 9. P1 flow control proportional valve |
| 5. Pressure sensor (N2)       |                                       |
- 
- |                  |                   |
|------------------|-------------------|
| a. Arm (1)       | f. Arm (2)        |
| b. Boom (2)      | g. Boom (1)       |
| c. Swing         | h. Bucket         |
| d. Option 1      | i. Travel (right) |
| e. Travel (left) |                   |

## Wiper relays - Prepare

Items to prepare:

- Wrench [ **10 mm**]
- Box wrench [ **10 mm**]
- Phillips Screw driver
- Screw driver

# Contents

---

## Electrical systems - 55

### FAULT CODES - DTC

#### DIAGNOSTIC

7000-P1 Pressure sensor signal abnormality [MCM] . . . . .	6
7001-P2 Pressure sensor signal abnormality [MCM] . . . . .	8
7002-N1 Pressure sensor signal abnormality [MCM] . . . . .	10
7003-N2 Pressure sensor signal abnormality [MCM] . . . . .	12
7020-Upper pressure sensor signal abnormality [MCM] . . . . .	14
7021-Swing pressure sensor signal abnormality [MCM] . . . . .	16
7022-Travel pressure sensor signal abnormality [MCM] . . . . .	18
7023-Arm-in pressure sensor signal abnormality [MCM] . . . . .	20
7040-Fuel level sensor signal abnormality [MCM] . . . . .	22
7041-Oil temperature sensor signal abnormality [MCM] . . . . .	24
7063-Return filter clog switch abnormality [MCM] . . . . .	26
7065-Boom-up pilot pressure sensor signal abnormality [MCM] . . . . .	29
7067-Bucket-close pilot pressure sensor signal abnormality [MCM] . . . . .	31
7200-Swing brake solenoid signal abnormality [MCM] . . . . .	33
7201-Travel high-speed solenoid signal abnormality [MCM] . . . . .	35
7202-Pressure boost solenoid signal abnormality [MCM] . . . . .	37
7203-Travel alarm buzzer signal abnormality [MCM] . . . . .	40
7206-Option line switchover solenoid signal abnormality [MCM] . . . . .	42
7212-Shut-off solenoid signal abnormality [MCM] . . . . .	44
7240-Pump horsepower proportional valve signal abnormality [MCM] . . . . .	46
7241-P1 flow control proportional valve signal abnormality [MCM] . . . . .	48
7246-2 pumps flow solenoid signal abnormality [MCM] . . . . .	50
7247-Boom-down proportional valve signal abnormality [MCM] . . . . .	52
7248-Arm-in proportional valve signal abnormality [MCM] . . . . .	54
7250-Option relief pressure proportional valve signal abnormality [MCM] . . . . .	56
7254-Washer output abnormality [MCM] . . . . .	58
7400-Abnormally high coolant temperature [105° C (221.0°F) or higher] 105° C (221.0°F) or higher] (55.640.AG-G.30.C.10) [[MCM] . . . . .	60
7401-Abnormally high coolant temperature [110° C (230.0°F) or higher] 110° C (230.0°F) or higher] (55.640.AG-G.30.C.10) [[MCM] . . . . .	61
7404-Abnormally high oil temperature [95 °C ( 203.0 °F ) or higher] 95 °C ( 203.0 °F ) or higher] (55.640.AG-G.30.C.10) [[MCM] . . . . .	62

Disconnect the bucket-close pressure sensor connector **CN.D55**.

Measure the resistance between the terminal 1 and terminal 3 of the bucket-close pressure sensor connector **(2)** **CN.D55** sensor side.

A. If the resistance is not about **10 k $\Omega$** , replace bucket-close pilot pressure sensor **(2)**.

B. If the resistance is about **10 k $\Omega$** , proceed to Step 7.

7. Inspect for continuity between the ground and terminal 1 of the bucket-close pressure sensor connector **(2)** **CN.D55** harness side.

Inspect for continuity between the ground and terminal 2 of the bucket-close pressure sensor connector **(2)** **CN.D55** harness side.

A. If there is continuity, find and replace the short circuit on the wire ID WL431, WL430 or LR446.

B. If there is no continuity, proceed to Step 8.

8. Inspect for continuity between the ground and terminal 3 of the bucket-close pressure sensor connector **(2)** **CN.D55** harness side.

A. If there is no continuity, find and repair or replace the open circuit on the wire ID BL451 or BL450.

B. If there is continuity, proceed to Step 9.

9. Turn ON the key switch.

Measure the voltage between the ground and terminal 1 of the bucket-close pressure sensor connector **(2)** **CN.D55** harness side.

A. If the voltage is not about **5 V**, find and repair or replace the open circuit on the wire ID WL431 or WL430.

B. If the voltage is about **5 V**, proceed to Step 10.

10. Measure the voltage between the ground and terminal 2 of the bucket-close pressure sensor connector **(2)** **CN.D55** harness side.

A. If the voltage is lower than **0.25 V**, find and repair or replace the open circuit on the wire ID LR446.

B. If the voltage is **0.25 V** or higher, replace computer B **(2)**.

**Wiring harnesses - Electrical schematic sheet 16 (55.100)**

## 7404-Abnormally high oil temperature [95 °C ( 203.0 °F ) or higher]

**Control Module : MCM**

**Solution:**

1. Use the below image for the fault code resolution process:

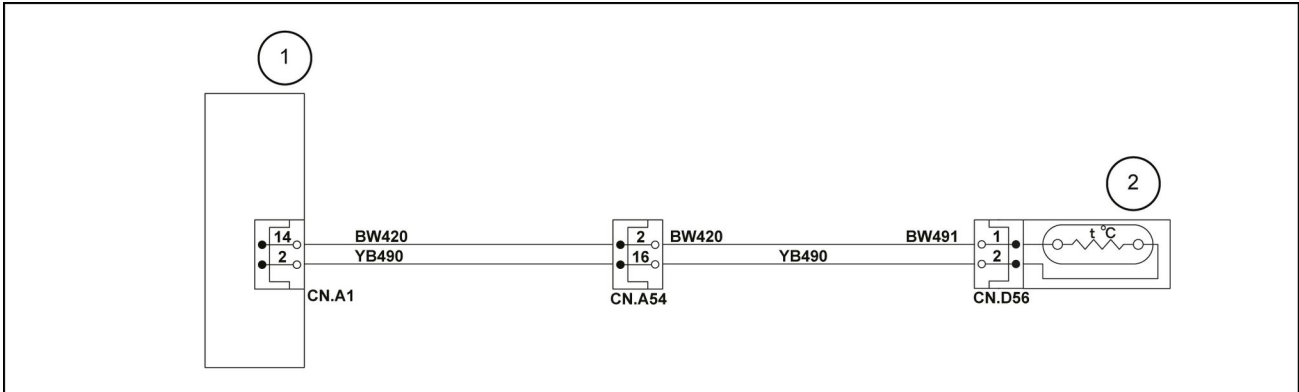

SML15CEX3290EB 1

1. Computer A
2. Hydraulic oil temperature sensor

Start the engine.

Perform a warm-up operation until engine is fully warmed up.

Check the Diagnostic Trouble Code on the service support DIAG screen.

A. If Diagnostic Trouble Code 7404 (●) is displayed, proceed to Step 2.

2. Inspect the hydraulic oil temperature.

---

## P0091-Fuel rail regulator control system low input

### Control Module : ECM

#### Solution:

1. Check the trouble code setting conditions before you proceed with the diagnostics code P0091.
  - Diagnostic trouble codes P060B and P160B are not detected.
  - The ECM detects that the feedback current of the suction control valve is **50 mA** or lower or **1000 mA** lower than the target current for **2 s.** or longer.
2. Disconnect the harness connector **CN.E13** from the suction control valve.

Connect a test lamp between the suction control valve high side circuit and normal ground.

Turn ON the starter switch.

Check if the test lamp illuminates, then goes off.

If it does not go off, inspect the high side circuit between the ECM and suction control valve.

Make sure that there is no open circuit or high resistance.

Make sure that there is no short circuit to ground.

Make sure that there is no short to the low side circuit.

  - A. If a problem is found, repair the high side circuit.
  - B. If there are no problems, proceed to Step 3.
3. Turn OFF the starter switch and keep it OFF for **1 min** or longer.

Connect a test lamp between the suction control valve low side circuit and the battery power supply.

Turn ON the starter switch.

Check if the test lamp illuminates, then goes off.

If it does not go off, inspect the low side circuit between the ECM and suction control valve.

Make sure that there is no open circuit or high resistance.

Make sure that there is no short to the battery or ignition power supply.

  - A. If a problem is found, repair the low side circuit.
  - B. If there are no problems, proceed to Step 4.
4. Inspect the suction control valve harness connector **CN.E13** for a poor connection.
  - A. If a problem is found, repair the harness connector **CN.E13**.
  - B. If the harness connector **CN.E13** is normal, replace the suction control valve. (Refer to “**Fuel shutoff solenoid - Remove (55.010)**” and “**Fuel shutoff solenoid - Install (55.010)**”).
  - C. If there are no problems, proceed to Step 5.
5. Inspect the ECM harness connector **CN.D1-02** for a poor connection.
  - A. If a problem is found, repair the harness connector **CN.D1-02**.
  - B. If the harness connector **CN.D1-02** is normal, replace the ECM. (Refer to “**Engine Control Unit (ECU) - Remove (55.015)**” and “**Engine Control Unit (ECU) - Install (55.015)**”).  
Set the injector ID code and the engine serial number on the ECM.

## **P0219-Engine overspeed condition**

### **Control Module : ECM**

#### **Solution:**

1. Check the trouble code setting conditions before you proceed with the diagnostics code P0219.
  - The ECM detects that the engine speed exceeded the specified speed for **5 s**.
2. Check and diagnose the below fault codes before you proceed with the diagnostics code P0219.
  - Diagnostic trouble code P0335
  - Diagnostic trouble code P0336
3. Turn OFF the starter switch and keep it OFF for **1 min**.

Start the engine.

Check the indicated engine speed with the trouble diagnosis scan tool.

Increase the engine speed as necessary.

Check the indicated engine speed with the trouble diagnosis scan tool.

  - A. If the no-load maximum speed is not exceeded, check with operator if there was an operating mistake that was caused by an overrun.
  - B. If there has been an engine overrun in the past, check the engine.
  - C. If there are no problems, proceed to Step 4.
4. Inspect the crankshaft position sensor. (Refer to “ **Engine speed/RPM sensor - Inspect (55.015)**”)
  - A. If there is an abnormality in the inspection result, replace the crankshaft position sensor. (Refer to “ **Engine speed/RPM sensor - Remove (55.015)**” and “ **Engine speed/RPM sensor - Install (55.015)**”).
5. Confirm resolution:
  1. Use the trouble diagnosis scan tool to delete the Diagnostic Trouble Code.
  2. Turn OFF the starter switch and keep it OFF for **1 min** or longer.
  3. Start the engine, increase the engine speed between idle and no-load maximum speed while checking the indicated engine speed with the trouble diagnosis scan tool.
  4. Check that the indicated speed does not exceed the no-load maximum speed.
  5. Use the trouble diagnosis scan tool to confirm that a Diagnostic Trouble Code has not been detected.

## **P0604-Internal control module random access memory (RAM) error**

### **Control Module : ECM**

#### **Solution:**

1. Check the trouble code setting conditions before you proceed with the diagnostics code P0604.
  - The ECM detects an internal RAM error.
2. Replace the ECM. (Refer to “ **Engine Control Unit (ECU) - Remove (55.015)**” and “ **Engine Control Unit (ECU) - Install (55.015)**”).  
Set the injector ID code and the engine serial number on the ECM.
3. Confirm resolution:
  1. Clear the Diagnostic Trouble Code using the trouble diagnosis scan tool.
  2. Turn OFF the starter switch and keep it OFF for **1 min** or longer.
  3. Start the engine.
  4. Perform a test-run under the conditions for running the Diagnostic Trouble Code.
5. Use the trouble diagnosis scan tool to confirm that a Diagnostic Trouble Code has not been detected.  
Conditions for setting the Diagnostic Trouble Codes such as engine run time or coolant temperature, etc., vary depending on the Diagnostic Trouble Codes.

4. Perform a test-run under the conditions for running the Diagnostic Trouble Code.
5. Use the trouble diagnosis scan tool to confirm that a Diagnostic Trouble Code has not been detected. Conditions for setting the Diagnostic Trouble Codes such as engine run time or coolant temperature, etc., vary depending on the Diagnostic Trouble Codes.

19. Inspect for high resistance in each circuit.
- If a problem is found, repair the circuit.
  - If the suction control valve harness connector **CN.E13** and ECM harness connector **CN.D1-02** are normal and there is no high resistance in any of the circuits, replace the fuel supply pump (refer to “**High pressure pump - Remove (10.218)**” and “**High pressure pump - Install (10.218)**”), and fuel filter (refer to “**Fuel filters - Remove (10.206)**” and “**Fuel filters - Install (10.206)**”).

**NOTE:** *When the fuel supply pump is replaced, the fuel filter must be replaced at the same time.*

- If the negative pressure is normal, turn OFF the starter switch.
  - If there are no problems, proceed to Step **20**.
20. Recover the fuel system.
- Start the engine.
- Perform an injector stop test with the trouble diagnosis scan tool.
- Check if there is an injector for which the engine speed does not change when the injector is instructed to go off.
- If there is an injector for which the engine speed does not change when the injector is instructed to go off, replace that injector. (Refer to “**Fuel injectors - Remove (10.218)**” and “**Fuel injectors - Install (10.218)**”).

- If there are no problems, proceed to Step **21**.

21. When replacing the injector, set the injector ID code to the ECM.
- If the engine speed changes when all the injectors are instructed to go off, replace the pressure limiter valve. (Refer to “**Common rail - Remove (10.218)**” and “**Common rail - Install (10.218)**”).

**NOTE:**

- The pressure limiter valve may be fixed open or the operating pressure may drop.*
- Do not replace the pressure limiter valve alone. If a problem is found, replace the common rail assembly.*

22. Confirm resolution:
- Clear the Diagnostic Trouble Code using the trouble diagnosis scan tool.
  - Turn OFF the starter switch and keep it OFF for **1 min** or longer.
  - Start the engine.
  - Perform a test-run under the conditions for running the Diagnostic Trouble Code.
  - Use the trouble diagnosis scan tool to confirm that a Diagnostic Trouble Code has not been detected. Conditions for setting the Diagnostic Trouble Codes such as engine run time or coolant temperature, etc., vary depending on the Diagnostic Trouble Codes.

**Wiring harnesses - Electrical schematic sheet 06 (55.100) Wiring harnesses - Electrical schematic sheet 07 (55.100) Wiring harnesses - Electrical schematic sheet 09 (55.100) Wiring harnesses - Electrical schematic sheet 15 (55.100)**

Items to prepare:

- Wrenches [ **10 mm**, **19 mm**, **22 mm**, **30 mm**, **36 mm**, **41 mm**]
- Hexagon wrench [ **12 mm**]
- Slide hammer [ **24 mm**]
- Nylon sling (that fulfills slinging capacity)
- Lifting equipment (that fulfills slinging capacity)
- Marking pen
- Cap
- Plug
- Rag
- Striking rod
- Cleaning fluid
- Wood protector
- Square wooden pieces
- Wires

## Bucket - Remove

**NOTE:** Place the back of the bucket parallel to the ground.

1. Remove the bolts (1) and the nuts (2).

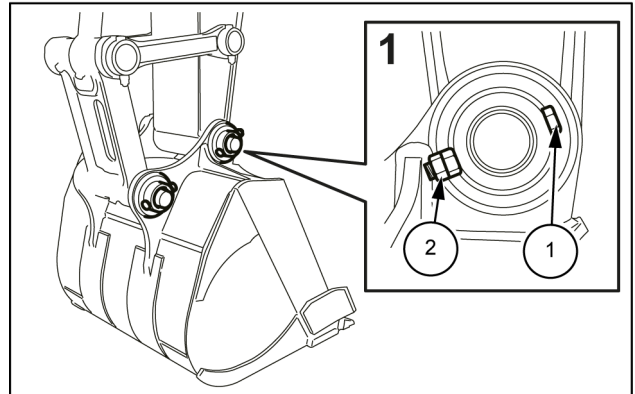

SMIL14CEX1369AB 1

2. Use a hammer (4) and striking rod (5) to push out the bucket side pin (3) and arm side pin (2), and then remove the bucket (1).

- When removing the pin, be careful not to damage the installed O-rings or dust seals.

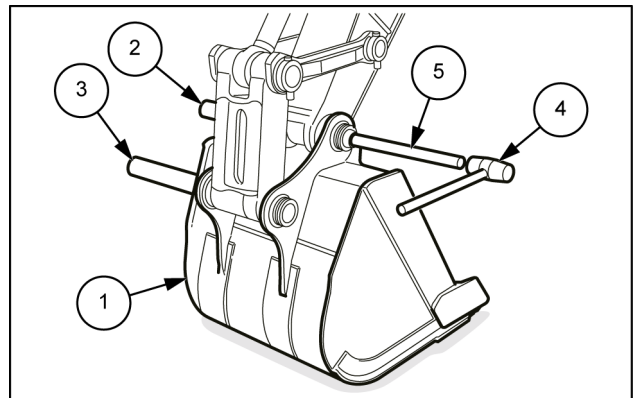

SMIL14CEX1370AB 2

CLICK HERE TO **DOWNLOAD** THE COMPLETE MANUAL

- Thank you very much for reading the preview of the manual.
- You can download the complete manual from: [www.heydownloads.com](http://www.heydownloads.com) by clicking the link below



- Please note: If there is no response to CLICKING the link, please download this PDF first and then click on it.

CLICK HERE TO **DOWNLOAD** THE COMPLETE MANUAL