

# CX300C TIER 4 CRAWLER EXCAVATOR SERVICE MANUAL COMPLETE CONTENTS

<b>COMPLETE SERVICE MANUAL</b> .....	<b>84483361</b>
<b>BOOK 1</b> .....	<b>84541700</b>
GENERAL INFORMATION	
<b>BOOK 2</b> .....	<b>84541701</b>
ENGINE	
FUEL SYSTEM	
<b>BOOK 3</b> .....	<b>84541702</b>
<b>BOOK 4</b> .....	<b>84541703</b>
ELECTRICAL SYSTEM	
<b>BOOK 5</b> .....	<b>84541704</b>
UNDERCARRIAGE	
DRIVE TRAIN	
<b>BOOK 6</b> .....	<b>84541705</b>
<b>BOOK 7</b> .....	<b>84541706</b>
UPPERSTRUCTURE HYDRAULICS	
<b>BOOK 8</b> .....	<b>84541707</b>
UPPERSTRUCTURE	
<b>COMPLETE CONTENTS</b> .....	<b>84541708</b>
<b>BINDER SPINE</b> .....	<b>84541709</b>
<b>ELECTRICAL POSTER</b> .....	<b>84420831NA</b>
<b>HYDRAULIC POSTER</b> .....	<b>84420833NA</b>

CLICK HERE TO **DOWNLOAD** THE COMPLETE MANUAL

- Thank you very much for reading the preview of the manual.
- You can download the complete manual from: [www.heydownloads.com](http://www.heydownloads.com) by clicking the link below



- Please note: If there is no response to CLICKING the link, please download this PDF first and then click on it.

CLICK HERE TO **DOWNLOAD** THE COMPLETE MANUAL

---

## SECTION 4008 - PREHEATING SYSTEM

BOOK 3 - 84541702

### CONTENTS

Description	Page
Removal and Installation of Glow Plug .....	3
Glow plug Removal .....	3
Glow plug Installation .....	4
Glow plug Inspection .....	5

## 4 - ELECTRICAL SYSTEM (CONT.)

### SECTION 4020A - ELECTRICAL EQUIPMENT LAYOUT DIAGRAM

BOOK 4 - 84541703

### CONTENTS

Description	Page
Electrical Equipment Layout Diagram .....	3
Main Unit Left Side Layout Diagram (radiator chamber) .....	5
Engine Section Layout Diagram .....	6
Main Unit Right Side Layout Diagram (pump chamber) .....	8
Main Unit Center Section Layout Diagram .....	10
Cab Layout Diagram 1 .....	11
Cab Layout Diagram 2 .....	13
Layout Around Operator Seat .....	15
Stand Alone Parts Diagram .....	17

### SECTION 4020B - CONNECTION CONNECTOR PIN LAYOUT

BOOK 4 - 84541703

### CONTENTS

Description	Page
Computer A .....	3
Monitor .....	4

---

## SECTION 8004 - REMOVAL AND INSTALLATION OF CONTROL VALVE

BOOK 6 - 84541705

### CONTENTS

Description	Page
Removal of Control Valve .....	3
Installation of Control Valve .....	7

## SECTION 8005A - REMOVAL AND INSTALLATION OF BUCKET CYLINDER

BOOK 6 - 84541705

### CONTENTS

Description	Page
Removal of Bucket Cylinder .....	3
Installation of Bucket Cylinder .....	6

## SECTION 8005B - REMOVAL AND INSTALLATION OF ARM CYLINDER

BOOK 6 - 84541705

### CONTENTS

Description	Page
Removal of Arm Cylinder .....	3
Installation of Arm Cylinder .....	6

## SECTION 8005C - REMOVAL AND INSTALLATION OF BOOM CYLINDER

BOOK 6 - 84541705

### CONTENTS

Description	Page
Removal of Boom Cylinder .....	3
Installation of Boom Cylinder .....	6

---

# SECTION 9006 - AIR CONDITIONER OVERALL DIAGRAM (CONT.)

BOOK 8 - 84541707

## CONTENTS

<b>Description</b>	<b>Page</b>
Mode Motor Actuator Inspection .....	33
Self-diagnosis Function with Panel Display .....	34
Abnormality Display and Self-check Procedures .....	34
Abnormality Display Position .....	34
Explanation of Abnormality Display .....	35
Motor Actuator Abnormality .....	35
Sensor Abnormality .....	36
Explanation of Monitor Mode .....	37
Monitor Mode Display Position .....	37
Monitor Mode Display Operating Method .....	38
Display Contents in Monitor Mode .....	39
Part Function and Good/Poor Judgment .....	45
Control Panel .....	45
Blower Amp .....	46
Relay .....	47
Air Mix Actuator .....	48
Blow Mode Actuator .....	49
Evaporator Sensor .....	49
Dual Pressure Switch .....	50
Solar Radiation Sensor .....	50
Inside Air Sensor .....	52



# Main Equipment Table (CX300C)

---

<b>Bucket cylinder</b>	
Stroke	1078 mm
Weight	207 kg

# Maintenance Standards

## 3. Boom and Boom Cylinder Installation Section

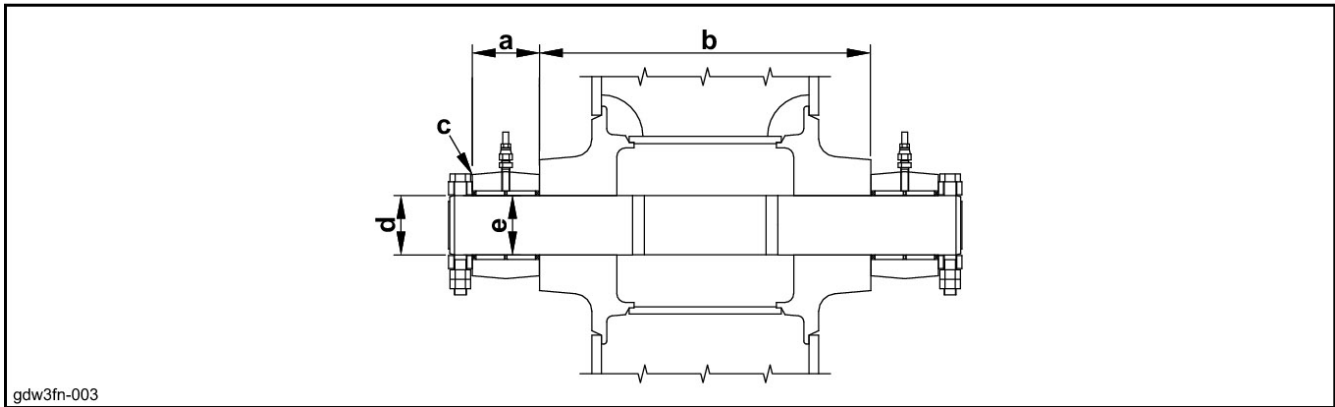

Part name	Cod-e	Measurement di-mension (mm)	Standard value (mm)	Usage limit (mm)	Judgment	Solution
Boom cylinder (top section)	a		113	111	Acceptable/ Unacceptable	Replacement
Boom	b		558	554	Acceptable/ Unacceptable	Replacement
Clearance	c		1.2 mm max.	Shim adjust- ment	Acceptable/ Unacceptable	Adjustment with shims
Pin	d	D	D100	D99	Acceptable/ Unacceptable	Replacement
Bushing (boom cylinder)	e	D	D100	D101.5	Acceptable/ Unacceptable	Replacement

# Bolt Size and Torque Table

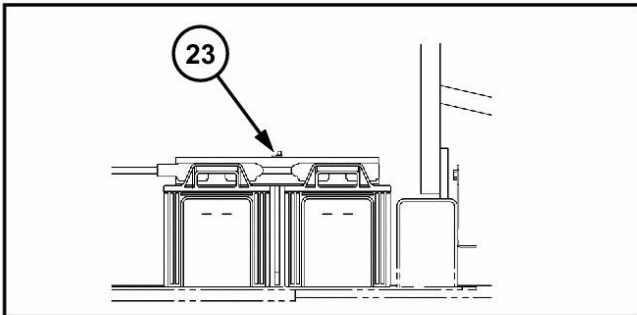
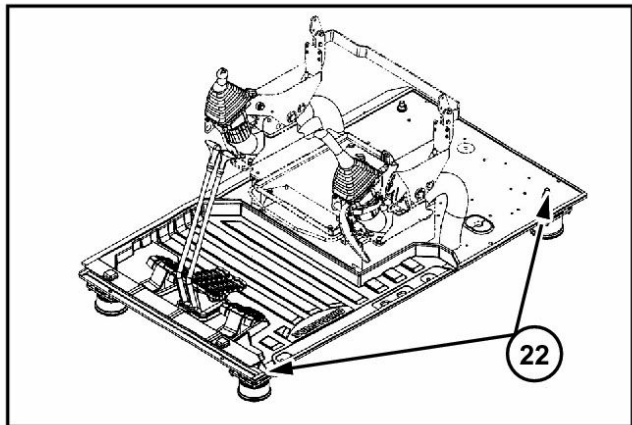
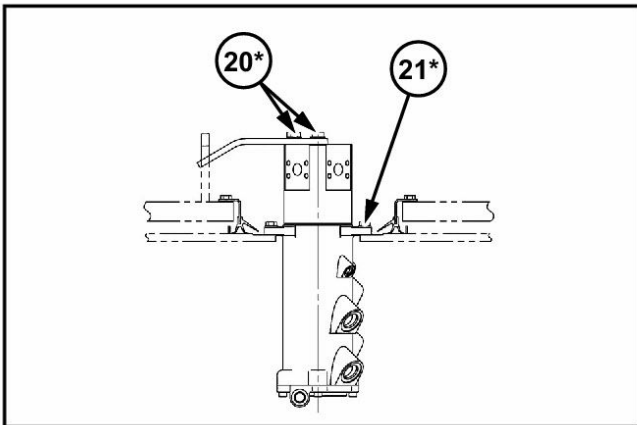
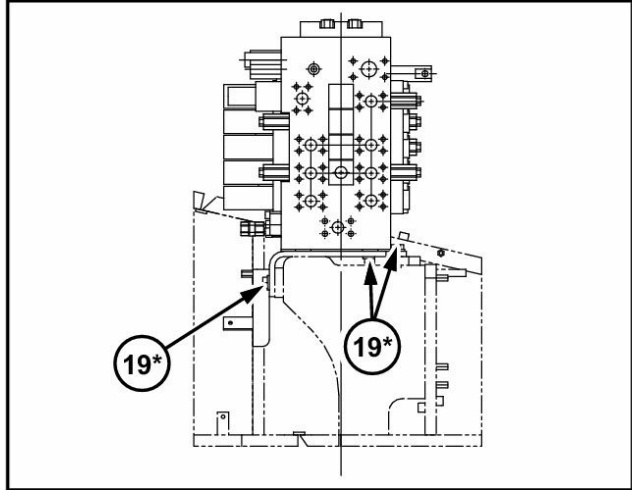
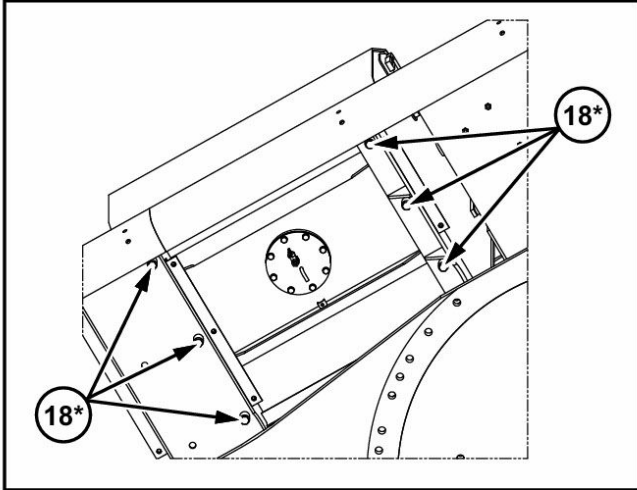

yysjmi-003

# List of special tools

mm

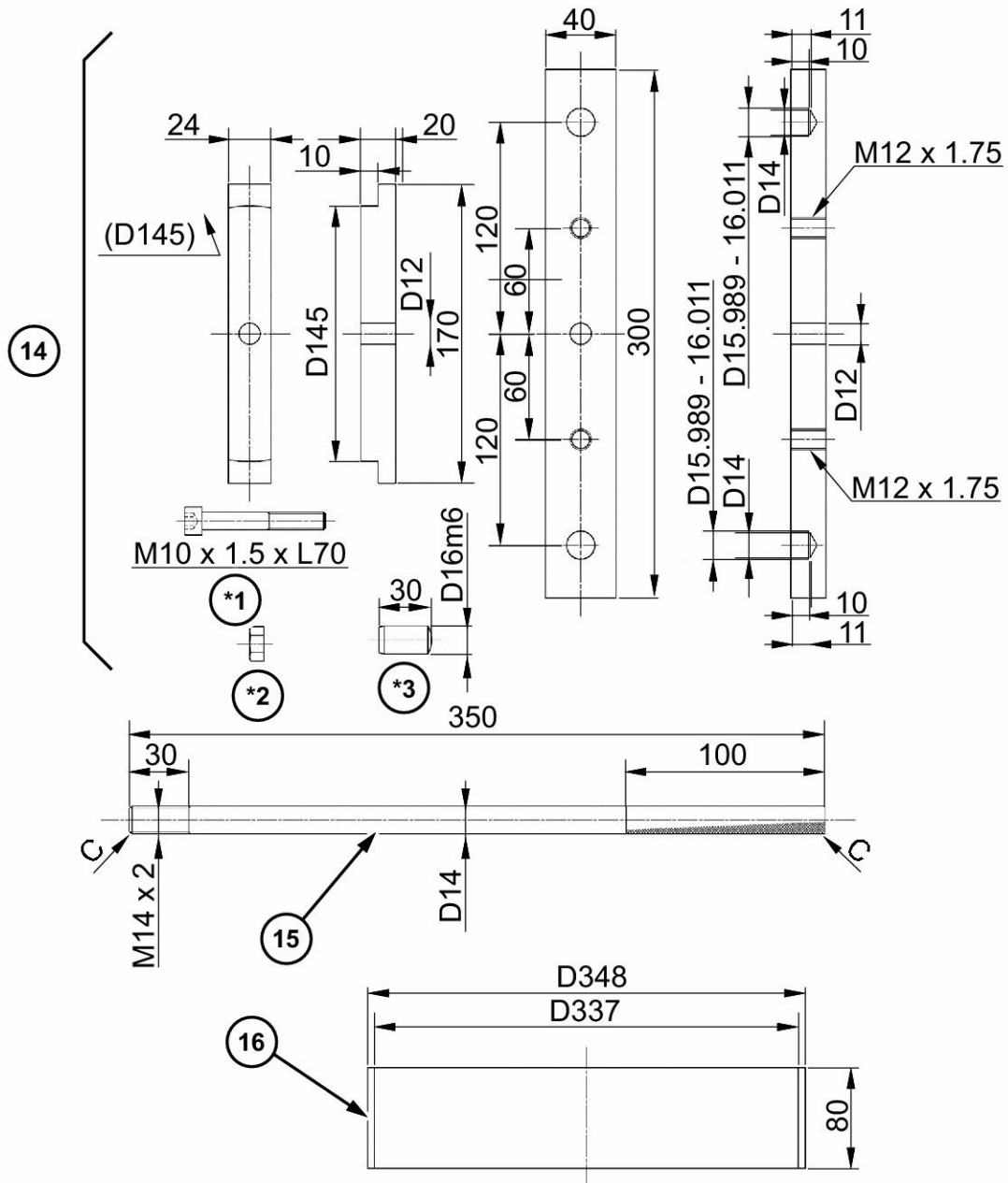

8mf167-005

Code	Order No.	Jig name	Remarks
14		Holder C subassembly lifting jig	*1: Socket head bolt (1) *2: M10 nut (1) *3: JIS B1354 Type A equivalent (2)
15		Motor assembly disassembly and assembly rod	
16		Angular bearing press-fit jig	

# List of special tools

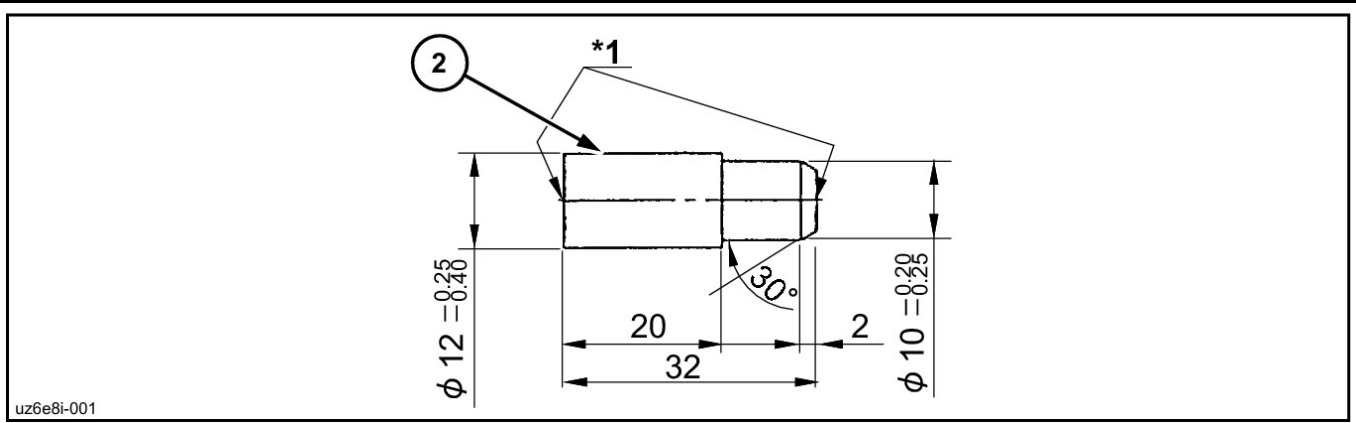

*1	Center hole possible ( $\phi$ 2 or less)
----	--

Code	Jig name	Remarks
2	Special jig 1 (for bushing removal)	

# Conversion Table

## U.S to Metric

	MULTIPLY	BY	TO OBTAIN
AREA:	square foot	0.092 903	square meter
	acre	0.404 686	hectare
FORCE:	ounce force	0.278 014	newton
	pound force	4.448 222	newton
LENGTH:	inch	25.4	millimeter
	foot	0.304 8	meter
	mile	1.609 344	kilometer
MASS:	pound	0.453 592	kilogram
	ounce	28.35	gram
MASS/AREA:	ton/acre	2241 702	kilogram/hectare
MASS/ENERGY:	lbs/hp/hr.	608.277 4	gr/kW/hr.
MASS/VOLUME:	lb/cubic yd.	0.593 276	kg/cubic meter
POWER:	horsepower	0.745 700	kilowatt
PRESSURE: psi	lb/sq. inch	6.894 757	kilopascal
	lb/sq. inch	0.069	bar
	lb/sq. inch	0.070 303	kg/sq. cm
	psi	0.006 895	megapascal (Mpa)
TEMPERATURE:	degree F	1.8 F - 32	degree C
TORQUE:	lb/inch	0.112 985	newton meter
	lb/foot	1.355 818	newton meter
VELOCITY:	miles/hr.	1.609 344	kilometer/hr
VOLUME:	cubic inch	16.387 06	cubic centimeter
	cubic foot	0.028 317	cubic meter
	cubic yd.	0.764.555	cubic meter
	ounce (US fluid)	29.573 53	milliliter
	quart (US liquid)	0.946 353	litre
	quart (Imperial)	1.136 523	litre
	gallon (US)	3.785 412	litre
	gallon (Imperial)	4.546 092	litre
VOLUME/TIME:	gallon/min.	3.785 412	litre/min.

# Removal and Installation of Engine Assembly

30. Install the 2 shackles (1), then use the wire rope (2) and liftcrane to secure the engine main unit.

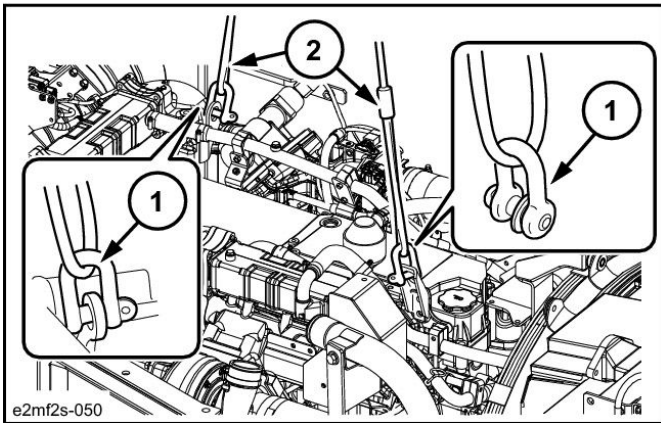

31. Use a box wrench (30 mm) to remove the 4 bolts (1) from the mount.  
Tightening torque for bolt installation: 289 - 337 N·m

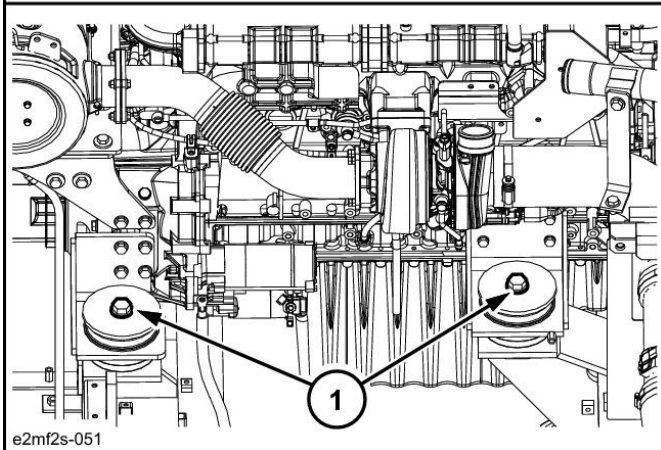
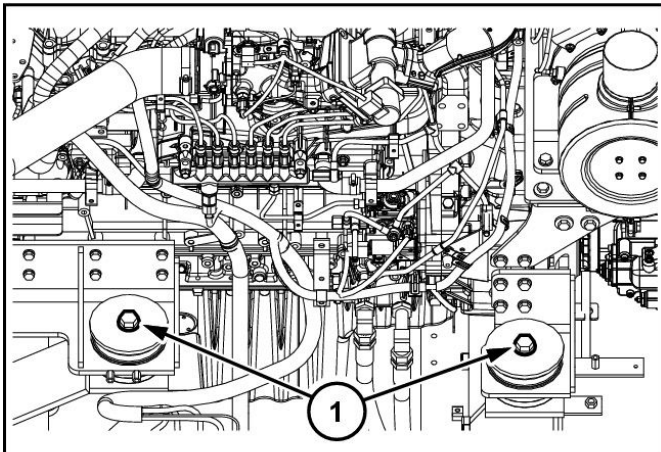

32. Use the wire rope (1) and liftcrane to lift the engine main unit.  
Thoroughly check that the location is safe before lowering the engine on wood planks, etc.

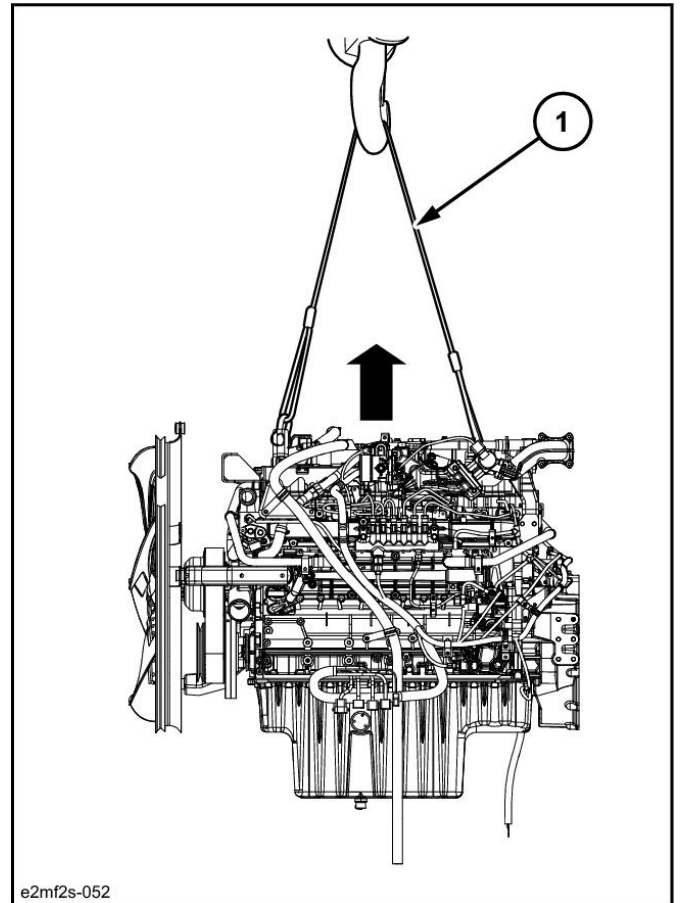

# CONTENTS

---

Removal of Turbo Charger .....	3
Installation of Turbo Charger .....	4



# Section

# 2007

**Removal and Installation of Muffler**

# Removal and Installation of Cylinder Head

- 2) Remove the EGR valve from the inlet pipe.

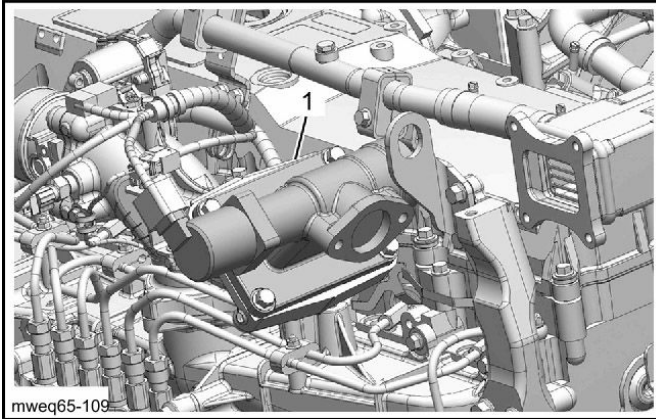

1	EGR valve
---	-----------

- 2) Remove the ventilation hose from the air breather.
- 3) Remove the oil separator bracket from the cylinder head assembly.

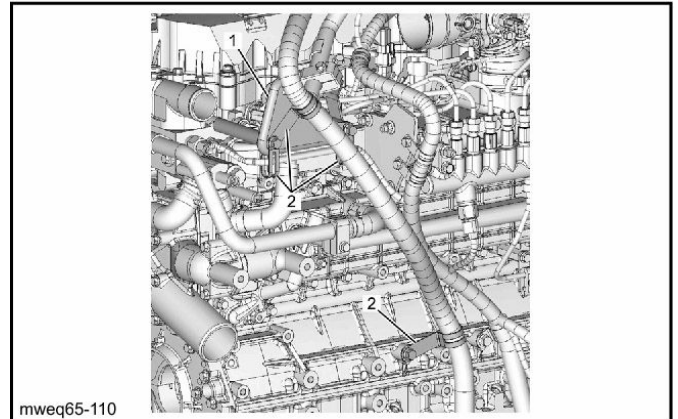

1	Oil separator bracket
2	Clip

7. Oil separator bracket Removal

- 1) Remove the clip from the cylinder block.

# Removal and Installation of Cylinder Head

- 2) Install the thermostat to the cylinder head assembly.

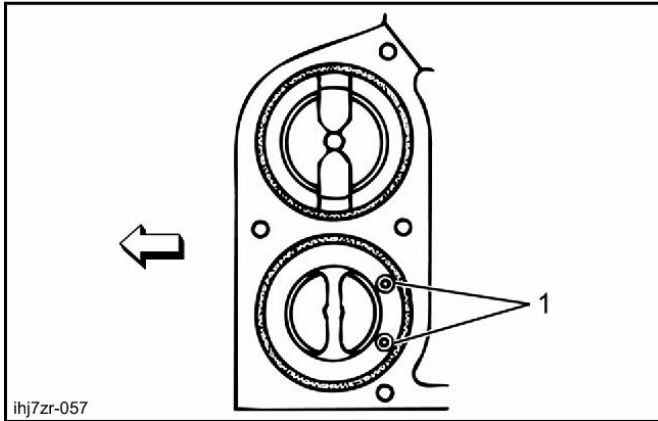

1	Jiggle valve position
---	-----------------------

**CAUTION**

- Be careful not to mistake the assembly position and direction.

- 3) Install the water outlet pipe to the cylinder head assembly.  
Tightening torque : 25 N· m { 2.5 kgf· m / 18.4 lb· ft }

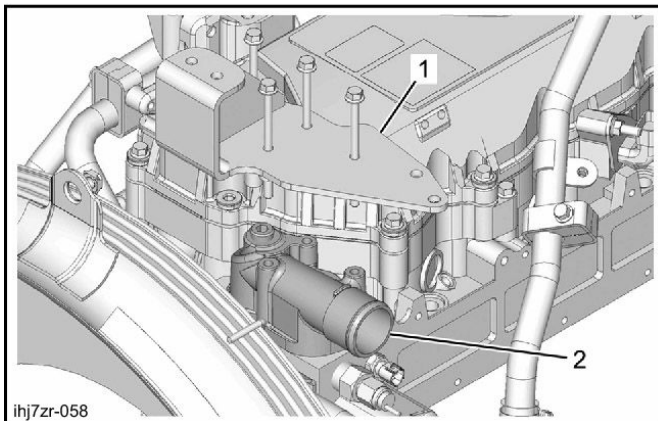

1	Fan guide bracket
2	Water outlet pipe

15. Bracket Installation

- 1) Install the EGR cooler bracket B to the cylinder head assembly.  
Tightening torque : 24 N· m { 2.4 kgf· m / 17 lb· ft }

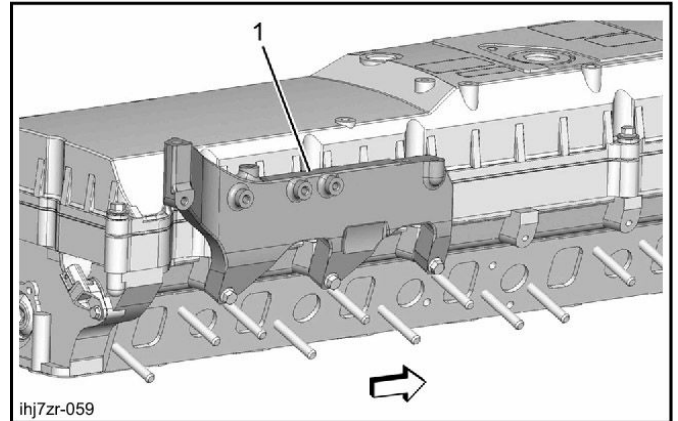

1	EGR cooler bracket B
---	----------------------

16. Exhaust manifold Installation

- 1) Install the gasket to the cylinder head assembly.

**ANNOTATION:**

- Install the gasket by turning the protruding section downward.

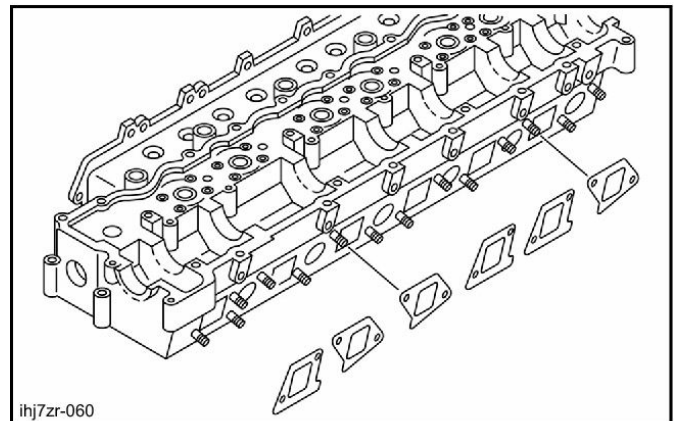

**CAUTION**

- Confirm that the gasket is firmly installed to the cylinder head.

**ANNOTATION:**

- It will ride on the casted surface of the cylinder head as shown in the diagram when installed incorrectly.

# Removal and Installation of Cylinder Head

## 3. Idle gear C Inspection

- 1) Measure the clearance using the feeler gauge.

### ANNOTATION:

- Measure the clearance in the axis direction between the cylinder head and idle gear C.

Specified value : 0.090 - 0.145 mm {0.0035 - 0.0057 in}

Limit : 0.20 mm {0.0079 in}

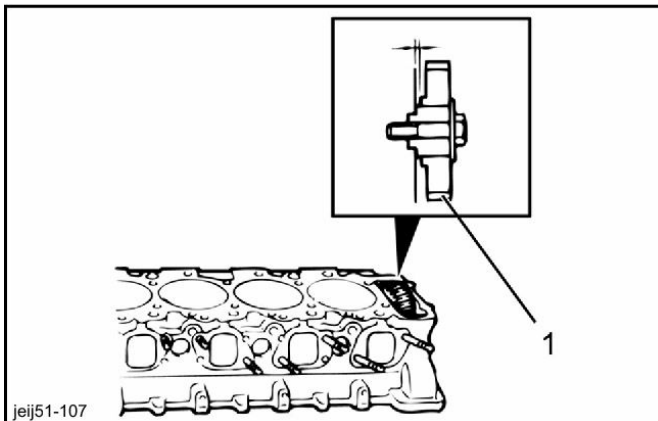

1	Idle gear C
---	-------------

- 2) Measure the idle gear shaft using the vernier caliper.

### ANNOTATION:

- Outer diameter of the idle gear shaft

Specified value : 30.00 mm {1.181 in}

Limit : 29.85 mm {1.1752 in}

## 4. Inlet valve Inspection

- 1) Measure the inlet valve using the micrometer.

### ANNOTATION:

- Outer diameter of the valve stem

Measurement part : 3 section(s)

Specified value : 8.0 mm {0.3150 in} Diameter

Limit : 7.88 mm {0.3102 in} Diameter

### ⚠ CAUTION

- Replace the inlet valve and valve guide if the measured value is under the limit value.

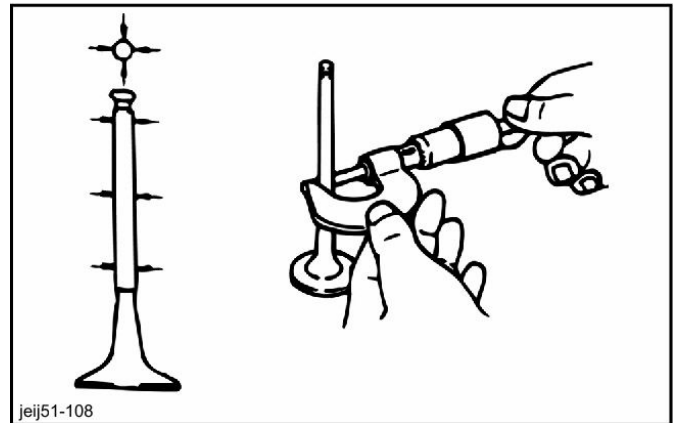

jeij51-108

- 2) Install the inlet valve to the valve guide.
- 3) Measure the valve guide clearance using the dial gauge.

### ANNOTATION:

- Valve guide clearance

Specified value : 0.039 - 0.071 mm {0.0015 - 0.0028 in}

Limit : 0.2 mm {0.0079 in}

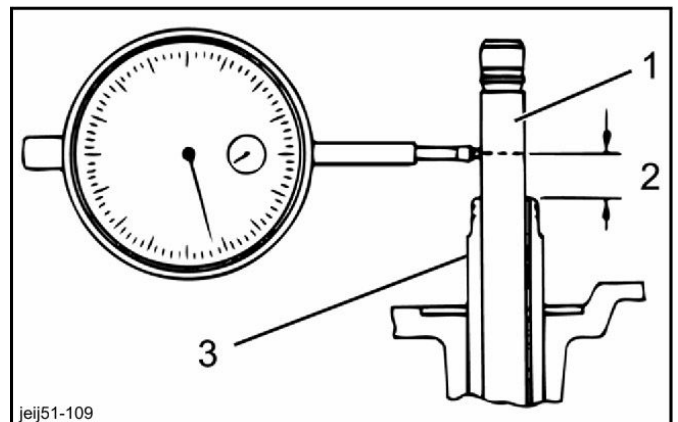

jeij51-109

1	Valve
2	The position 10 mm under the valve guide head
3	Valve guide

### ⚠ CAUTION

- Replace the inlet valve and valve guide if the measured value exceeds the limit value.

- 4) Measure the inlet valve using the micrometer.

### ANNOTATION:

- Valve thickness

Specified value : 1.71 mm {0.0673 in}

Limit : 1.30 mm {0.0512 in}

# Removal and Installation of Cylinder Block

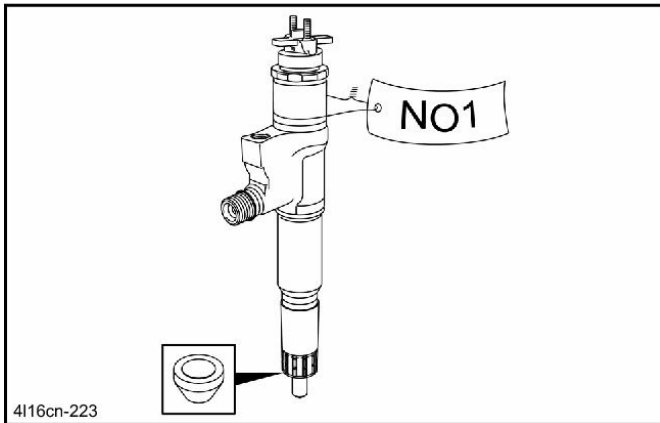

## 28. Lower cover Removal

- 1) Remove the lower cover from the cylinder head assembly.
- 2) Remove the rubber plug from the cylinder head assembly.

## 29. Rocker arm shaft Removal

- 1) Loosen the adjust screw using the wrench.

### **ANNOTATION:**

- Loosen all valve clearance adjustment screws.

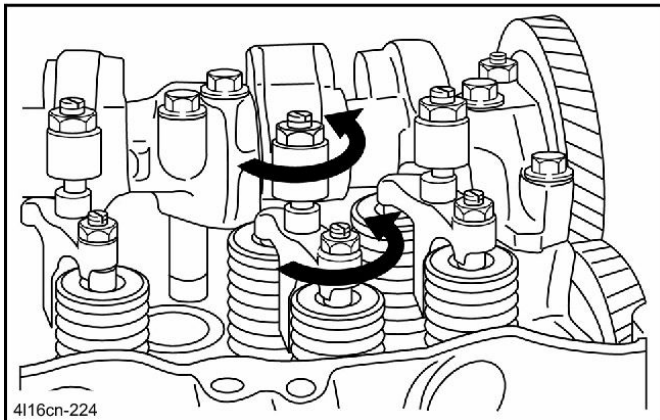

- 2) Remove the rocker arm shaft from the cylinder head assembly.

### **ANNOTATION:**

- Evenly loosen the rocker arm shaft bracket and the rocker arm assembly bracket tightening bolts from both ends and remove them.

### **CAUTION**

- Be careful not to remove the bolt shown in the diagram.

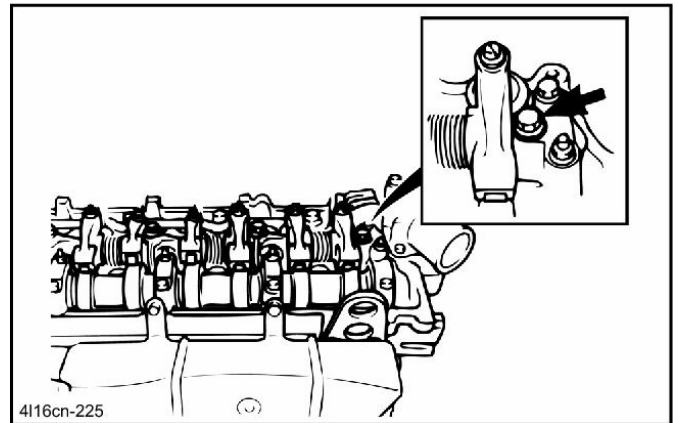

## 30. Camshaft Removal

- 1) Remove the camshaft bearing cap from the cylinder head assembly.
- 2) Remove the camshaft bearing from the camshaft bearing cap.
- 3) Remove the camshaft from the cylinder head.
- 4) Remove the camshaft bearing from the cylinder head assembly.

### **ANNOTATION:**

- Temporarily assemble the removed caps and bearings in the original position to avoid a mix-up after the bearings have been inspected.

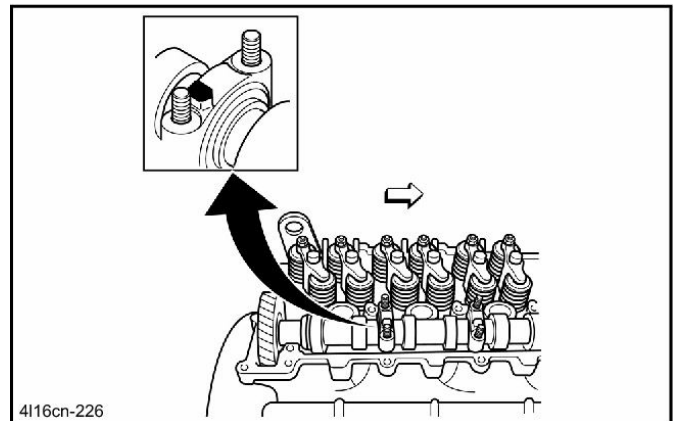

## 31. Bridge Removal

- 1) Remove the bridge cap from the bridge.

### **CAUTION**

- Be careful not to drop the bridge cap into the engine.

# Removal and Installation of Cylinder Block

- 1) Install the starter assembly to the flywheel housing.  
Tightening torque : 82 N· m {8.4 kgf· m / 60.5 lb· ft}
- 2) Connect the earth cable to the starter assembly.  
Tightening torque : 19 N· m {1.9 kgf· m / 14.0 lb· ft}

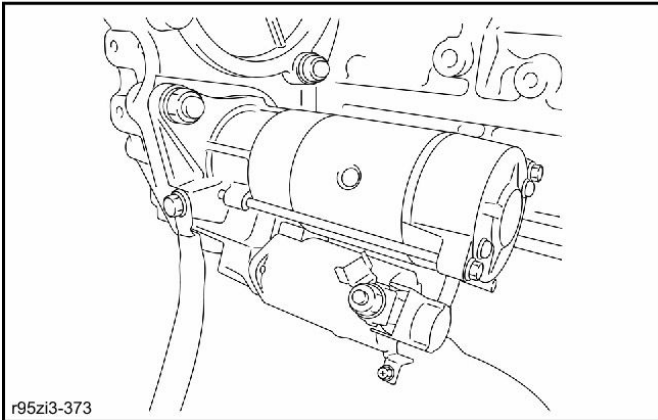

- 3) Align the fuel supply pump to the cylinder block.

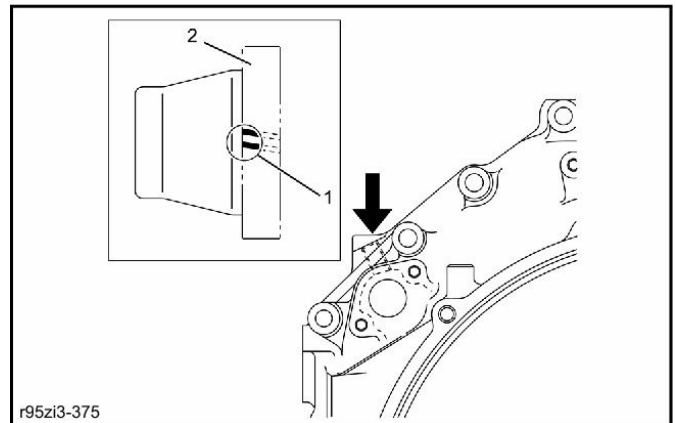

1	Confirmation hole
2	Supply pump gear

## 17. Fuel supply pump Installation

- 1) Align 1st cylinder to the compression top dead center.
- 2) Align alignment mark to the bracket.

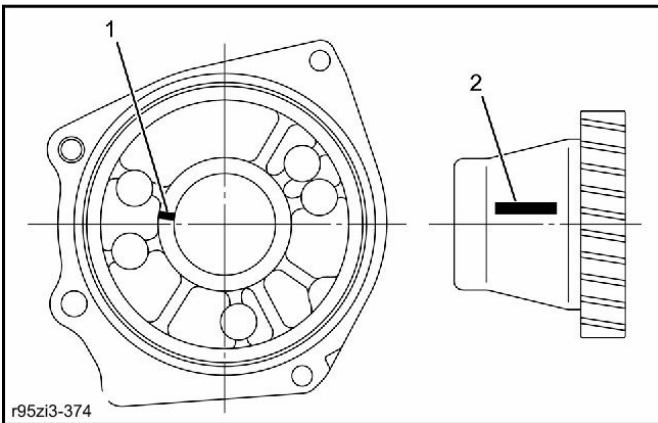

1	Supply pump bracket side slit
2	Supply pump gear side alignment mark

- 4) Install the fuel supply pump to the cylinder block.

Tightening torque : 75 N· m {7.6 kgf· m / 55 lb· ft} No.5 in the diagram  
 Tightening torque : 75 N· m {7.6 kgf· m / 55 lb· ft} No.8 in the diagram  
 Tightening torque : 51 N· m {5.2 kgf· m / 38 lb· ft} No.10 in the diagram

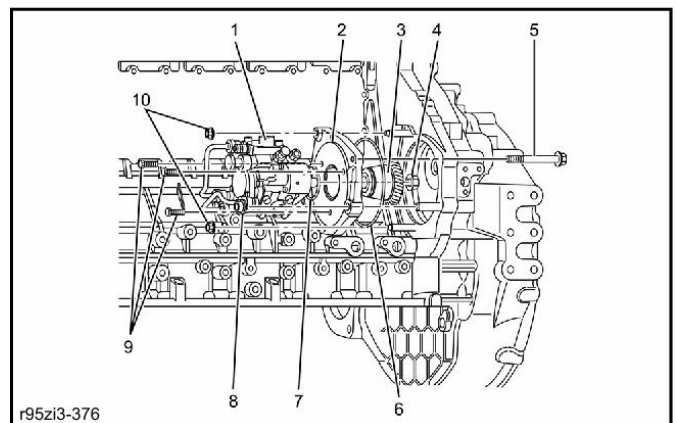

1	Fuel supply pump
2	Bracket
3	Gear
4	Nut
5	Bolt
6	O-ring
7	O-ring
8	Nut
9	Bolt
10	Nut

- 5) Connect the harness connector to the fuel supply pump.

## 18. Cylinder head assembly Installation

# Removal and Installation of Cylinder Block

- 1) Press the drive belt.

**ANNOTATION:**

- Measure the amount of drive belt flex by pressing on the point indicated by the arrow in the diagram with the specified pressure.

Standard : 98.0 N {10.0 kg / 22 lb}  
 Specified value : 5.5 - 7.5 mm {0.2165 - 0.2953 in} Amount of flex

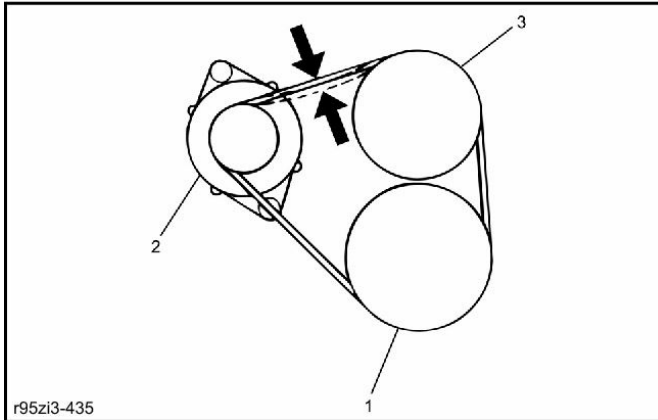

r95zi3-435

1	Crankshaft pulley
2	Generator
3	Fan pulley

- 2) Adjust the drive belt to standard value using the adjust bolt.  
 Tightening torque : 75 N·m {7.6 kgf·m / 55.3 lb·ft} Nut of the adjust plate  
 Tightening torque : 126 N·m {12.8 kgf·m / 92.9 lb·ft} Bolt of the bracket side

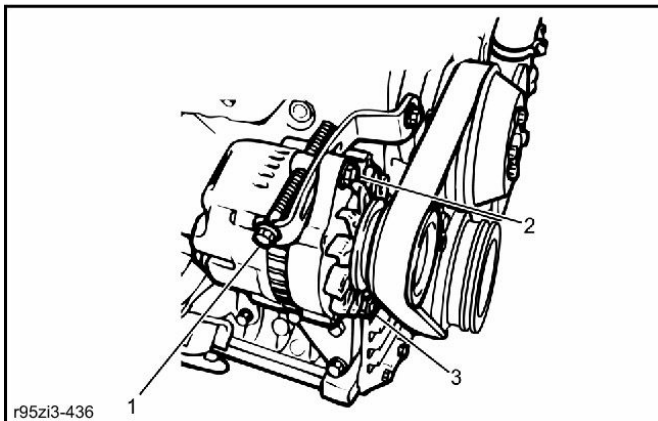

r95zi3-436

1	Adjust bolt
2	Adjust plate side nut
3	Bracket side bolt

## 46. Fan guide Installation

- 1) Install the fan guide bracket to the engine assembly.  
 Tightening torque : 40 N·m {4.1 kgf·m / 29.5 lb·ft}

- 2) Install the fan guide to the fan guide bracket.  
 Tightening torque : 30 N·m {3.1 kgf·m / 22.1 lb·ft}

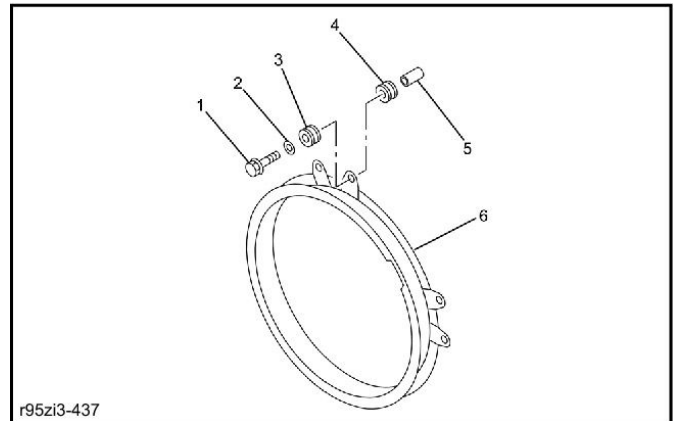

r95zi3-437

1	Bolt
2	Washer
3	Rubber mount
4	Rubber mount
5	Guide tube
6	Fan guide

## 47. Cooling fan Installation

- 1) Install the cooling fan to the adapter.

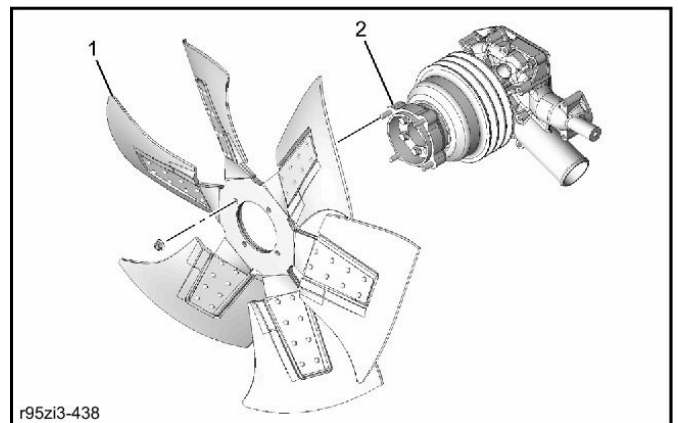

r95zi3-438

1	Cooling fan
2	Adapter

Tightening torque : 52 N·m {5.3 kgf·m / 38.4 lb·ft}

## 48. Engine harness Connect

- 1) Connect the engine harness to the engine assembly.

**ANNOTATION:**

- Connect each connector.

## 49. Engine oil Filling

# Lubrication System

- Remove the cylinder head gasket from the cylinder block.

**⚠ CAUTION**

- Do not reuse the cylinder head gasket.

## 26. Fuel supply pump Removal

- Disengage the harness connector from the fuel supply pump.
- Remove the fuel supply pump from the cylinder block.

**ANNOTATION:**

- Remove together with the bracket.

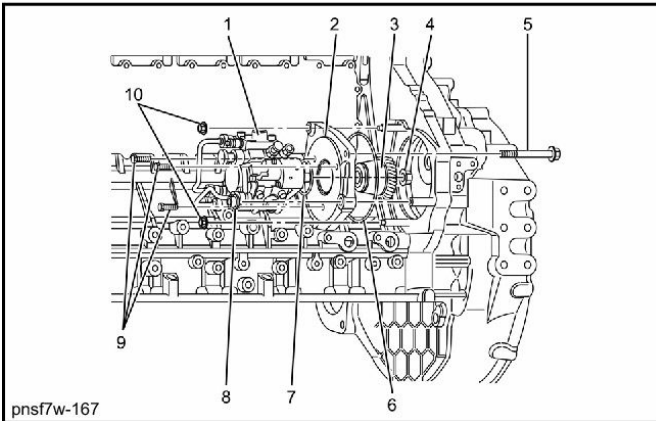

1	Fuel supply pump
2	Bracket
3	Gear
4	Nut
5	Bolt
6	O-ring
7	O-ring
8	Nut
9	Bolt
10	O-ring

## 27. Starter assembly Removal

- Disengage the earth cable from the starter assembly.
- Remove the starter assembly from the flywheel housing.

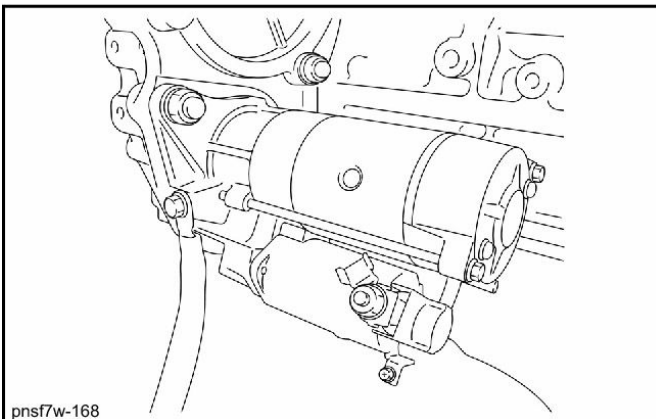

## 28. CKP sensor Removal

- Disengage the harness connector from the CKP sensor.
- Remove the CKP sensor from the flywheel housing.

**⚠ CAUTION**

- Be careful not to subject the sensor to shock.

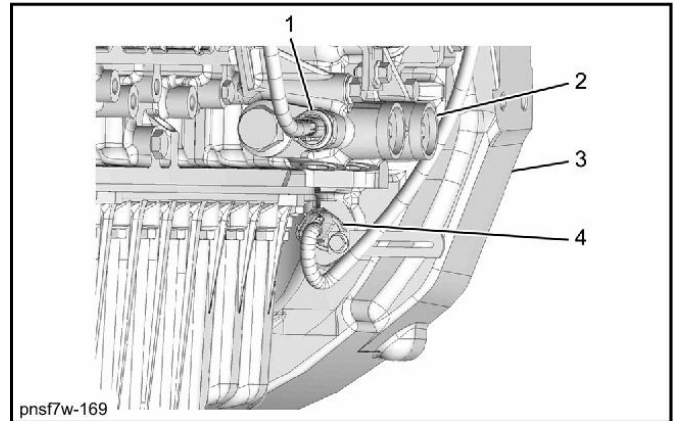

1	Oil pressure switch
2	Oil port cover
3	Flywheel housing
4	CKP sensor

## 29. Flywheel Removal

- Remove the flywheel from the crankshaft.

**ANNOTATION:**

- Gradually loosen the flywheel installation bolts in the order shown in the diagram.

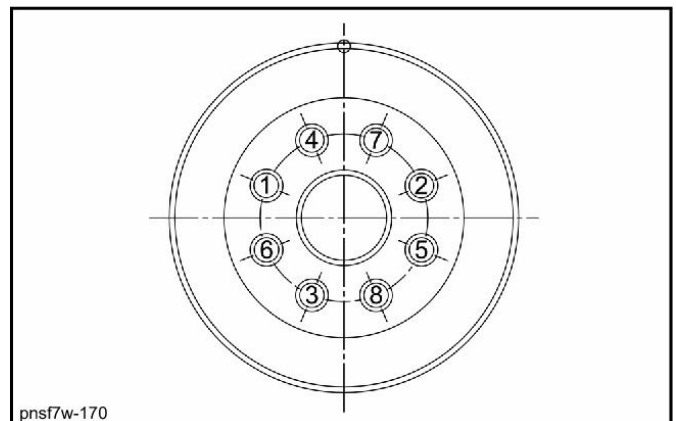

**⚠ CAUTION**

- Fix the flywheel firmly so that it will not rotate.

## 30. Crankshaft rear oil seal Removal

- Remove the crankshaft rear oil seal from the crankshaft using the special tool.

# Lubrication System

- 1) Install the inlet pipe to the inlet cover.  
Tightening torque: 25 N·m {2.5 kgf·m / 18 lb·ft}

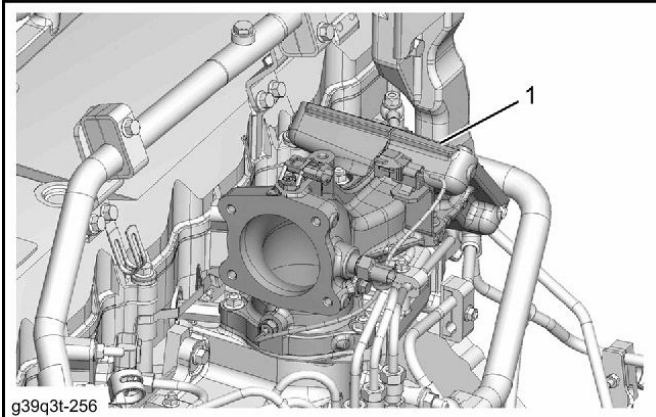

- 2) Connect the harness connector to the boost sensor.
- 3) Connect the harness connector to the boost temperature sensor.
- 4) Connect the harness connector to the IMT sensor.
- 5) Install the harness clip to the inlet pipe.  
Tightening torque: 24 N·m {2.4 kgf·m / 17 lb·ft}

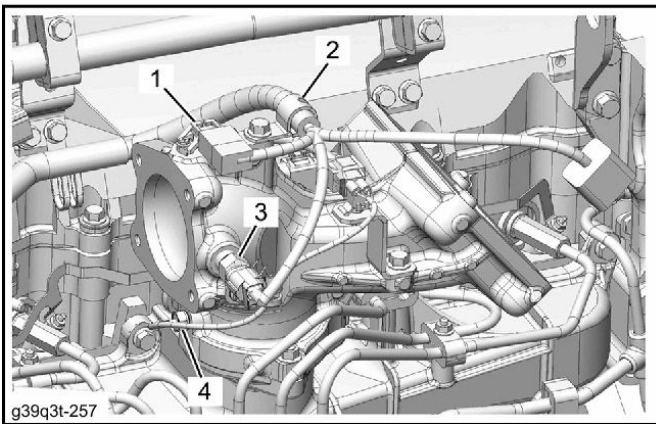

1	Boost sensor
2	Harness clip
3	Boost temperature sensor
4	IMT sensor

- 1) Install the intake throttle valve to the inlet pipe.  
Tightening torque: 24 N·m {2.4 kgf·m / 17 lb·ft}

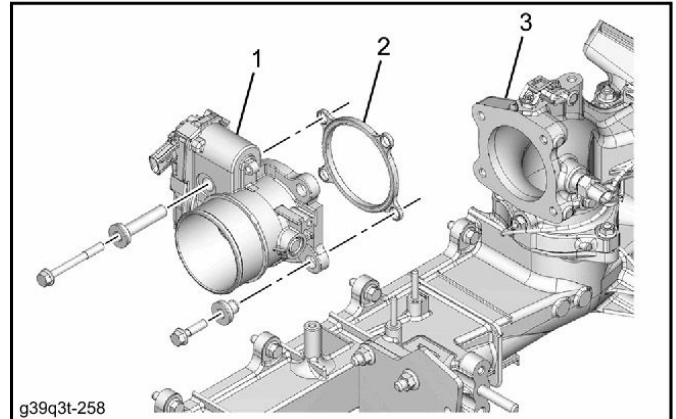

1	Intake throttle valve
2	Gasket
3	Inlet pipe

- 2) Install the air duct to the intake throttle valve.
- 3) Connect the harness connector to the intake throttle valve.

**ANNOTATION:**

- After connecting the harness connector, press in the lock operation portion to lock.

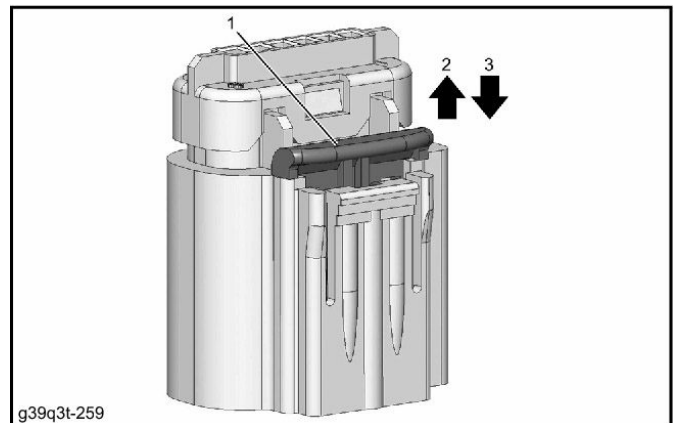

1	Lock operation section
2	Lock release
3	Lock

25. Intake throttle valve Installation

# Cooling System

## Water pump assembly Inspection

### 1. Water pump assembly Inspection

- 1) Inspect the water pump assembly.

**ANNOTATION:**

- Cracks and damage on the water pump body
- Cracks and corrosion on the impeller
- Water leak from the seal unit

**CAUTION**

- If any abnormality is found in the inspection, replace the water pump assembly.

- 2) Inspect the bearing unit.

**ANNOTATION:**

- Rotate the fan while pushing the fan center to the radius direction and inspect for any significant looseness or abnormal sounds.

**CAUTION**

- If any abnormality is found in the inspection, replace the water pump assembly.

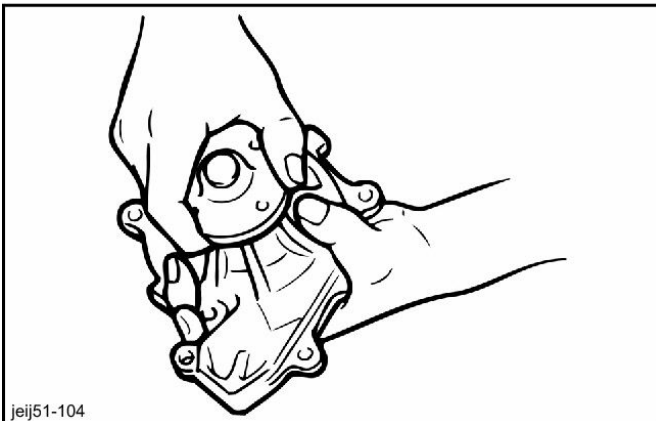

## Removal and Installation of Thermostat

### Thermostat Removal

1. Battery ground cable Disconnect

- 1) Disengage the battery ground cable from the battery.

2. Coolant Drain

- 1) Drain the coolant from the radiator.

**CAUTION**

- After the coolant is discharged, make sure to tighten the drain plug.

3. Thermostat Removal

- 1) Remove the fan guide stay from the fan guide and the fan guide bracket.

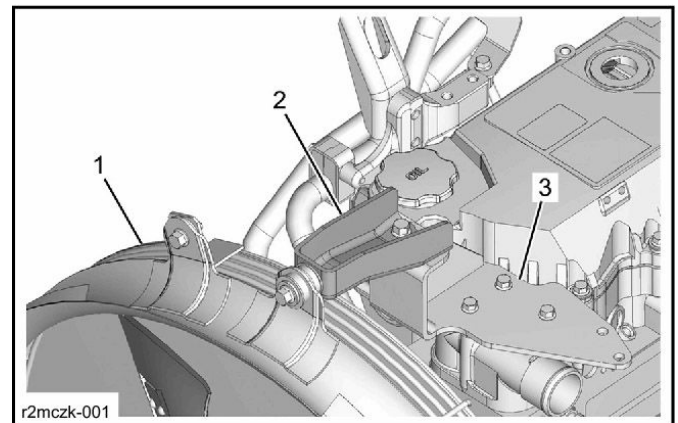

1	Fan guide
2	Fan guide stay
3	Fan guide bracket

- 2) Disengage the radiator upper hose from the water outlet pipe.

- 3) Remove the water outlet pipe from the cylinder head assembly.

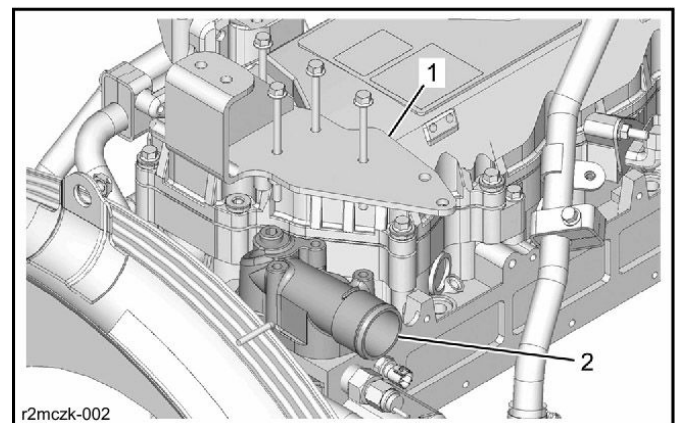

1	Fan guide bracket
2	Water outlet pipe

# CONTENTS

---

DPD assembly Disassembly .....	3
DPD assembly Reassembly .....	5
DPD assembly Inspection .....	7

# Removal and Installation of Fuel Supply Pump

## Fuel supply pump Removal

1. Battery ground cable Disconnect
  - 1) Disengage the battery ground cable from the battery.

2. Engine harness Disconnect
  - 1) Disengage the engine harness from the engine assembly.

**ANNOTATION:**

- *Disconnect each connector.*

3. Fuel pipe Removal
  - 1) Remove the fuel pipe from the fuel supply pump and the common rail assembly.

**ANNOTATION:**

- *Remove the clip.*

**⚠ CAUTION**

- **Do not reuse the removed fuel pipe.**

4. Fuel leak off pipe assembly Removal
  - 1) Disengage the fuel leak-off pipe from the cylinder head.
  - 2) Remove the fuel leak-off pipe from the fuel supply pump.

**ANNOTATION:**

- *Remove the eyebolt tightened together with the fuel feed pipe.*

- 3) Disengage the fuel leak-off pipe from the common rail assembly.
- 4) Remove the fuel leak-off pipe from the inlet pipe.

**ANNOTATION:**

- *Remove the clip.*

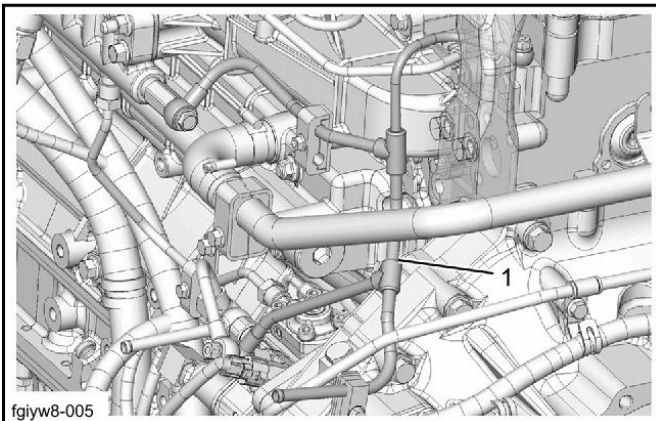

1	Fuel leak-off pipe
---	--------------------

- 2) Remove the fuel supply pump from the cylinder block.

**ANNOTATION:**

- *Remove together with the bracket.*

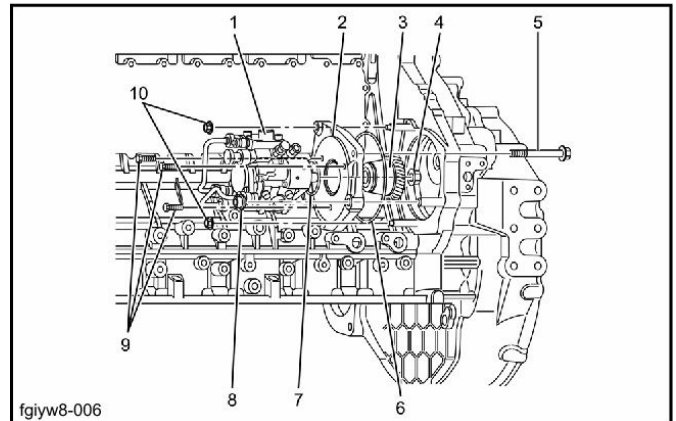

1	Fuel supply pump
2	Bract
3	Gear
4	Nut
5	Bolt
6	O-ring
7	O-ring
8	Nut
9	Bolt
10	Nut

5. Fuel supply pump Removal
  - 1) Disengage the harness connector from the fuel supply pump.

# CONTENTS

---

Injector Removal .....	3
Injector Installation .....	5

# Electrical and Engine Basic Functions

## Clock

### Purpose

Displays the time on the monitor.

### Operation explanation

- The time is always displayed on the monitor.
- The clock continues to operate, without display, when the key is turned OFF. (Because it uses power from the battery)

## Fuel Economy Gauge

### Purpose

Displays the fuel economy on the monitor.

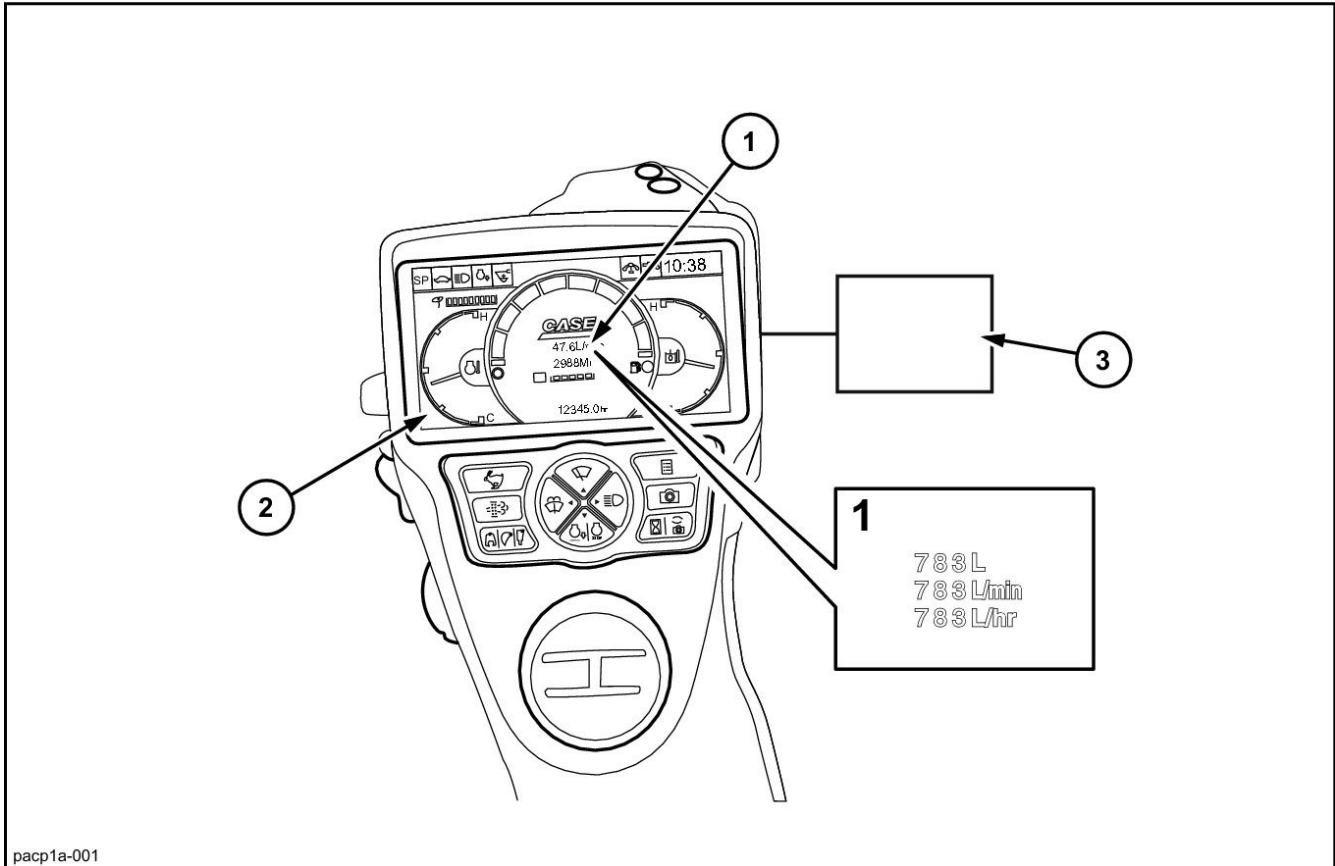

1	Fuel economy gauge
2	Monitor
3	Computer A

### Operation explanation

1. The fuel economy gauge is displayed on the monitor after the key is turned ON.
2. When trouble occurs, the fuel economy gauge goes off and the diagnostic trouble code is displayed.
3. When the trouble is recovered from, the diagnostic trouble code goes off and the fuel economy gauge is displayed again.

# Electrical and Engine Basic Functions

1. Operation conditions for travel alarm

The operation starts under the following conditions.

- 1) When a travel operation is being performed.(Travel pressure sensor ON)

2. End conditions for travel alarm

The operation ends under the following conditions.

- 1) When the travel operation is stopped.
- 2) When 10 sec. or longer elapses while a travel operation is being performed.

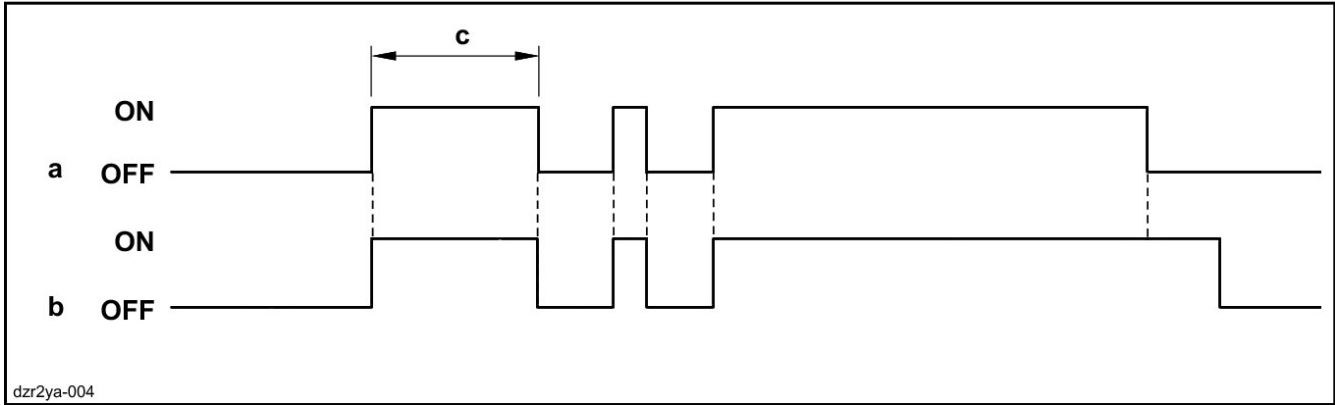

a	Travel alarm
b	Pressure sensor (travel)
c	10 sec.

# Electrical and Engine Basic Functions

- Monitor buzzer: The buzzer sounds at the same time that the message is displayed and the buzzer automatically stops after 5 sec.
4. Clog switch trouble detection: Before engine starting, the contact point of the clog detection switch should be closed (B contact point). However, if the circuit is open (continuously for 1 sec.), it is judged that the clog detection switch is disconnected, the "Electrical system abnormality" message and diagnostic trouble code "7063" are displayed, and the buzzer sounds for 5 sec..
5. Time chart:

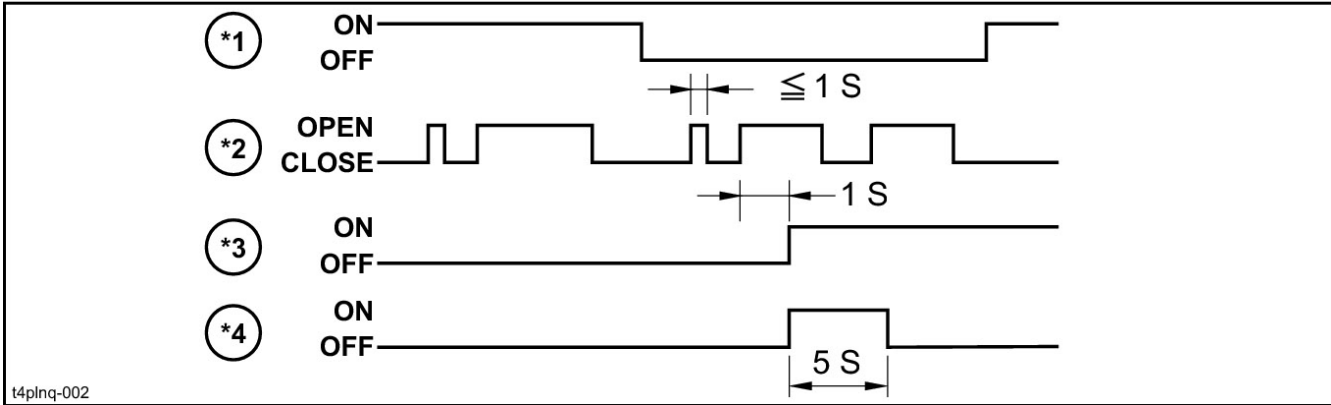

*1	1st option pressure switch	*3	Message trouble card
*2	Hydraulic oil filter clog switch	*4	Monitor buzzer

# Service Support

## 4. Pressure and solenoid

MACHINE STATUS		4/13
BOOM-UP PILOT PRESS.	0 1 . 0 0	MPa
ARM-CLOSE PILOT PRESS.	0 0 . 8 0	MPa
BUCKET-CLOSE PILOT PRESS.	0 0 . 4 2	MPa
BOOM-DOWN PSOL.	0 0 5 0	mA
BOOM-UP P-SOL	0 0 5 0	mA
ARM-CLOSE PSOL.	0 4 2 0	mA
BUCKET-CLOSE PSOL.	0 0 5 0	mA
OFFSET-LEFT PSOL.	0 0 5 0	mA
BUCKET-OPEN SOL.	+ + + +	on/off

zbvdpc-019

## 5. Pressure and solenoid

MACHINE STATUS		5/13
PILOT SW.	● ● ○ ○	on/off
P1 PRESS.	0 3 2 . 5	MPa
P2 PRESS.	0 3 2 . 5	MPa
N1 PRESS.	0 3 . 8 0	MPa
N2 PRESS.	0 3 . 8 0	MPa
OPT.LINE RELIEF PSOL.	0 4 2 0	mA
OPTION 2SPEED SOL.	+ + + +	on/off
OPTION SELECT SOL.	+ + + +	on/off
POWER BOOST SOL.	+ + + +	on/off

zbvdpc-020

BOOM-UP PILOT PRESS.	MPa	Boom-up pilot pressure
ARM-CLOSE PILOT PRESS.	MPa	Arm-in pilot pressure
BUCKET-CLOSE PILOT PRESS.	MPa	Bucket-close pilot pressure
P.SOL;BOOM-DOWN	mA	Boom-down solenoid
P.SOL;BOOM-UP	mA	Boom-up solenoid
P.SOL;ARM-CLOSE	mA	Arm-in solenoid
P.SOL;BUCKET-CLOSE	mA	Bucket-close solenoid
P.SOL;OFFSET-LEFT	mA	Offset left solenoid
SOL;BUCKET OPEN	on/off	Bucket-open solenoid

PILOT SW.	on/off	Pilot switch
P1 PRESS.	MPa	Pump 1; Discharge pressure
P2 PRESS.	MPa	Pump 2; Discharge pressure
N1 PRESS.	MPa	Pump 1; Negative control pressure
N2 PRESS.	MPa	Pump 2; Negative control pressure
P.SOL;OPT.LINE RELIEF	mA	Option line solenoid
SOL;OPTION 2SPEED	on/off	2 pumps flow solenoid
SOL;OPTION SELECT	on/off	Option selection solenoid
SOL;POWER BOOST	on/off	Power boost solenoid

# Service Support

Page	Item name	Explanation	Remarks
3		-	
	REMOTE SUPPORT	Remote Support	Currently not supported; used for Computer ST trouble diagnosis
	FMS	Fuel abnormality warning	Currently not supported; used for density sensor trouble diagnosis
	RESERVE 1	Free Swing	
	RESERVE 2	Reserve 2	Not currently supported
	RESERVE 3	Reserve 3	Not currently supported
		-	
		-	

Explanation of number

1. Model (Machine)  
Omitted
2. Destination (Territory)

Value	Details	Remarks
0	JAPAN	
1	NA	Travel alarm continuous buzzing function ON (Cannot be set OFF)
2	- (Skipped number)	
3	EU	
4	IHI	
5	TURK	
6	CHINA	

3. Brand

Value	Details	Remarks
0	SUMITOMO	Background color = blue, Sumitomo logo displayed after model selection completed
1	LBX	Background color = black, LBX logo displayed after model selection completed
2	CASE	Background color = black, CASE logo displayed after model selection completed
3	IHI	Not currently supported, background color = ?

# Function, Structure, Operation

Common rail

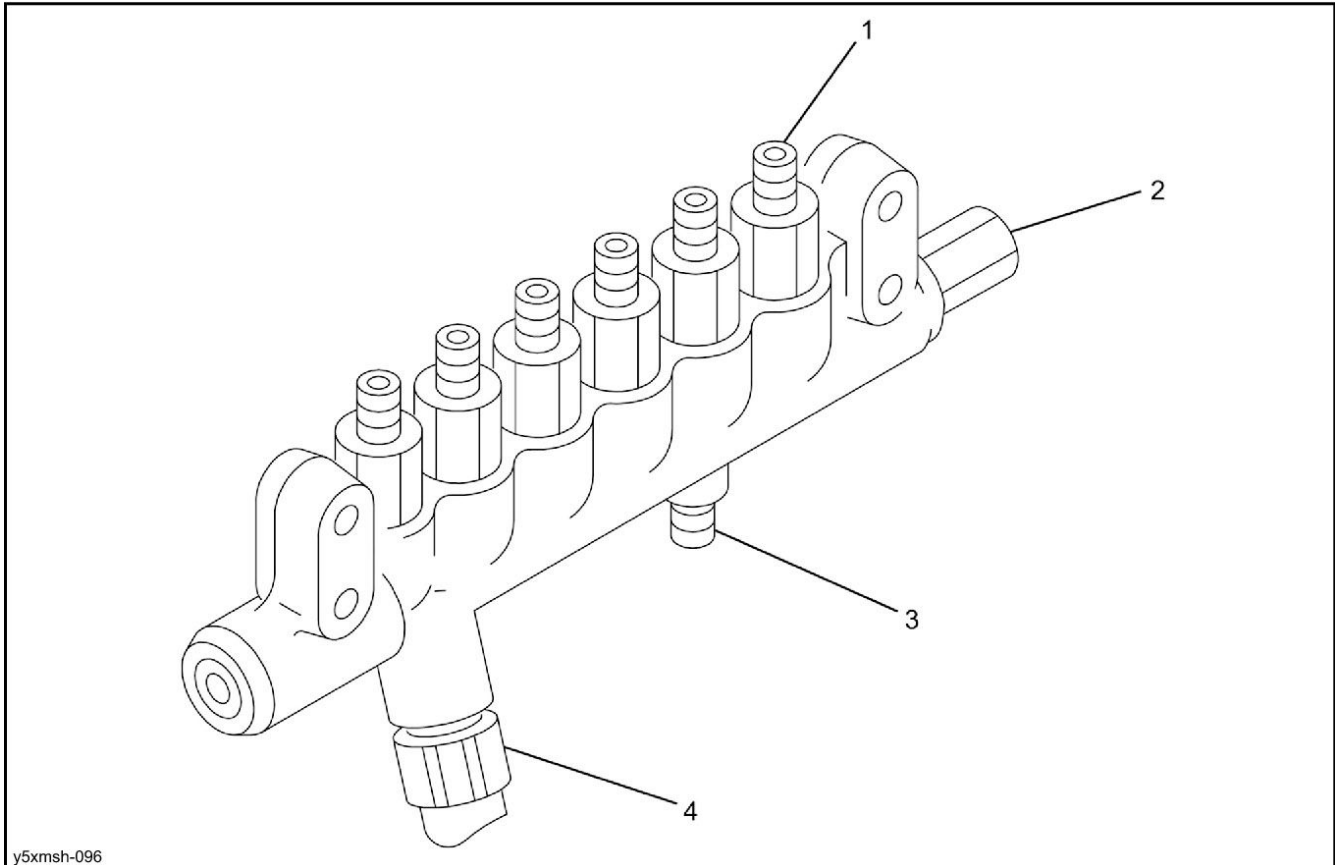

y5xmsh-096

1	Flow damper	3	Fuel inlet
2	Pressure limiter	4	Pressure sensor

# Function, Structure, Operation

## Control during overheat

To protect the engine, restriction on fuel flow is started when the engine coolant temperature exceeds 100 °C (212 °F).

When the engine coolant temperature increases further, the fuel flow is also restricted further.

When the temperature reaches 110 °C (230 °F), a failure is recorded in the ECM.

When the temperature is near 120 °C (248 °F), the fuel flow is restricted to a certain level.

The setting varies depending on the actual unit manufacturer.

The actual unit is designed to issue an alarm from 105 °C (221 °F).

By reducing the load applied to the actual unit upon alarm issuance, it is possible to avoid the operation condition with fuel flow restriction.

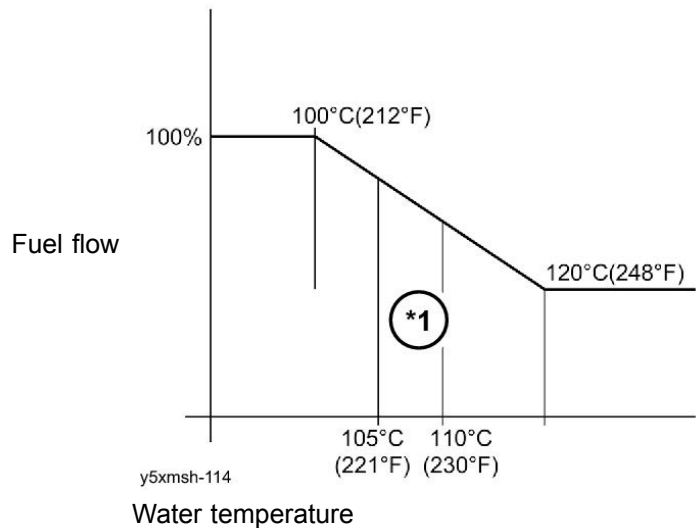

\*1 Warning indication DTC set

If the ECM is equipped with an emergency stop function by a high engine coolant temperature, it stops the engine when the temperature has reached 105 °C (221 °F).

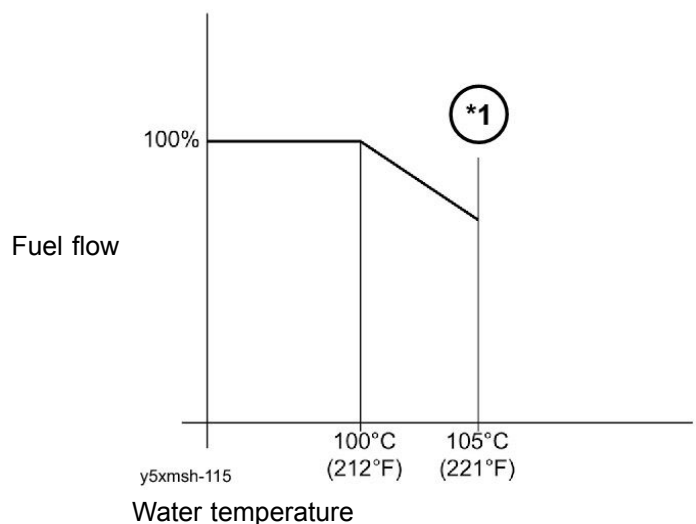

\*1 Engine emergency stop

# Function, Structure, Operation

## Engine RPM output to tachometer

The ECM outputs the engine rpm pulse to the tachometer as a tachometer output.

The tachometer displays the engine RPM based on the engine RPM pulse sent from the ECM.

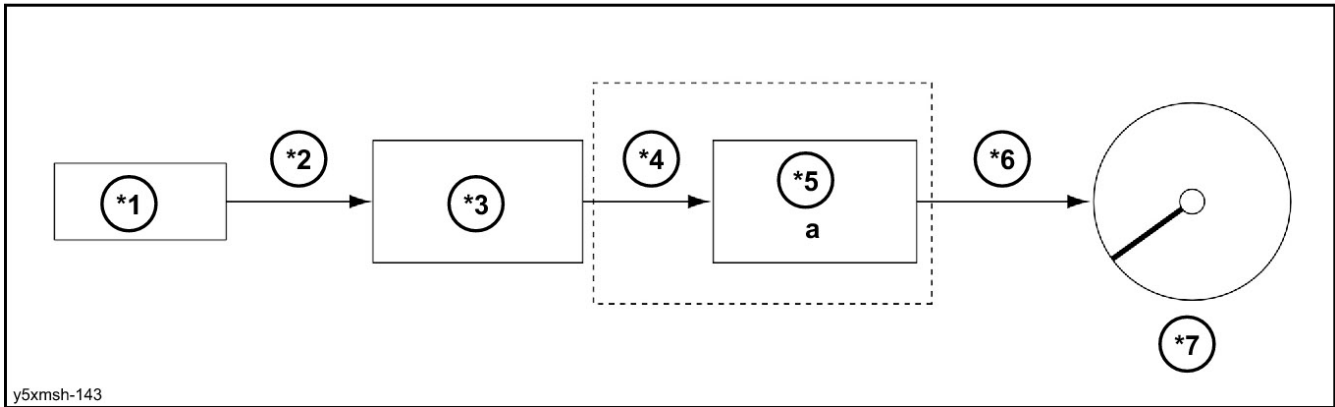

y5xmsh-143

a Output from machine control unit by machine

*1	CKP sensor	*4	CAN communication	*7	Tachometer
*2	Engine speed	*5	Control unit on machine side		
*3	Engine control module (ECM)	*6	Tachometer output		

## Preheat control

### QOS system

The ECM determines the glow time according to the engine coolant temperature, and activates the glow relay and the QOC indicator light.

The QOS system is a system to facilitate engine start in a low temperature as well as reducing the amount of white smoke and noise generated immediately after engine start.

When the starter switch is turned ON, the ECM detects the temperature of the engine coolant based on the signal sent from the water temperature sensor to change the glow time, so the engine can be always started under the optimum conditions.

Also, the after-glow function can stabilize the idling immediately after engine start.

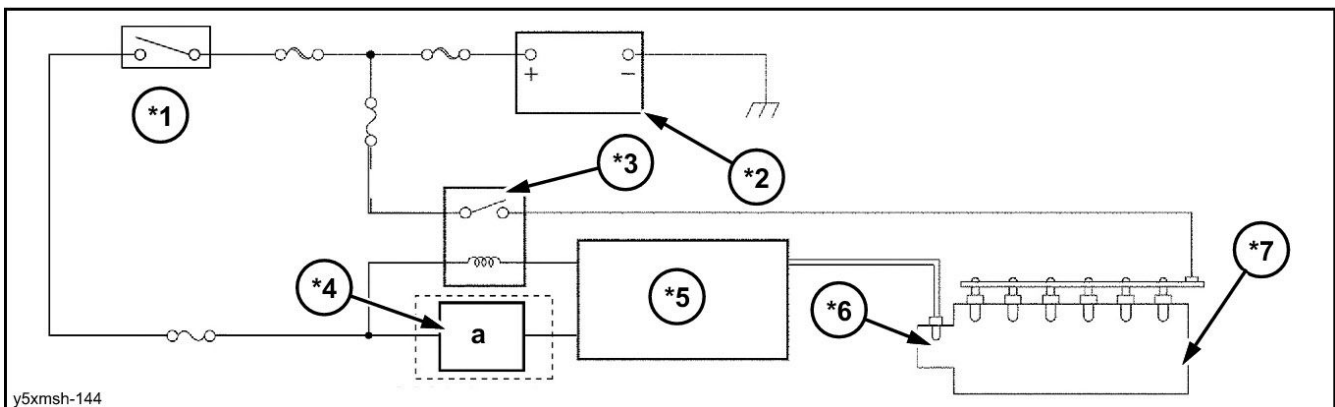

y5xmsh-144

a LCD or Lamp

*1	Starter switch (ON)	*4	QOS indicator lamp	*7	Glow plug
*2	Battery	*5	(ECM)		
*3	Glow relay	*6	Water temperature sensor		

# Function, Structure, Operation

## IMT sensor

The IMT sensor is a variable resistance installed on the intake manifold to measure the intake temperature of the intake manifold.

When the sensor is cold, the sensor resistance is high.

When the intake temperature rises, the sensor resistance decreases.

For low sensor resistance, the ECM detects a low voltage of the signal circuit.

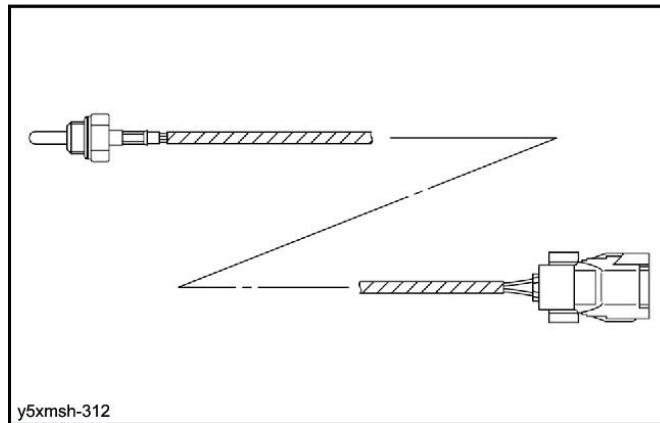

## Turbocharger

The turbocharger has an actuator with built-in control unit installed.

The opening angle of the turbocharger variable nozzle is driven by the actuator.

The built-in control unit performs CAN communication, and the ECM performs control that changes the boost pressure by adjusting the nozzle opening angle in accordance with the load requirement for the engine.

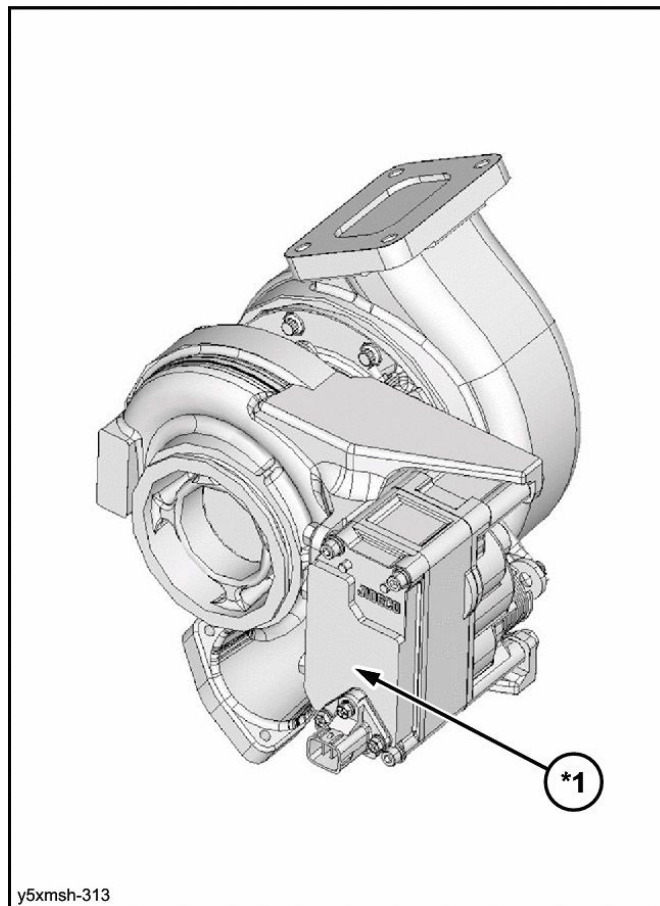

*1	Turbo actuator
----	----------------

# Symptom

customer's expense, instruct the customer not to use mixed oil biofuel containing long-term storage fuel and organic substances.

When using fuel with a high water content, add the larger sedimenter to the pre-fuel filter to prevent water from entering into the fuel system.

Abnormalities of the supply pump, non-pressure fuel supply

The ECM determination of the supply pump non-pressure fuel supply DTC will not be detected unless a condition continues for 3 seconds or more in which the engine revolution speed is  $900 \text{ min}^{-1}$  {900 r/min} and the absolute pressure is below 15 MPa {153 kgf/cm<sup>2</sup> / 2175 psi}.

Therefore, the DTC will not be detected when the engine does not start with non-pressure fuel supply due to the supply pump abnormalities.

## ANNOTATION:

- Since the crankshaft position sensor abnormalities will not be diagnosed unless cranking is performed 14 revolutions or more, crank for more than 14 seconds at  $60 \text{ min}^{-1}$  {60 r/min} or more. For crankshaft position sensor errors at low engine revolution speed, the crankshaft position sensor DTC may not be detected. For intermittent failure, increase the engine revolution speed to No Load Max and check if the crankshaft position sensor related DTC is detected.

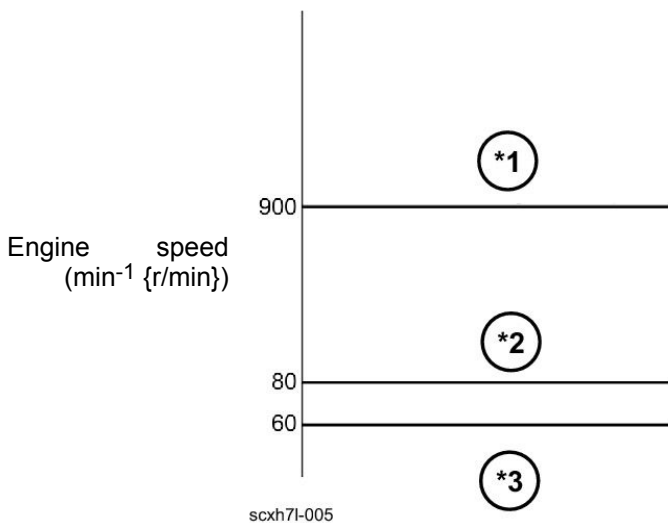

*1	P0093 Judgment required engine speed
*2	Minimum fining engine speed
*3	System realization engine speed

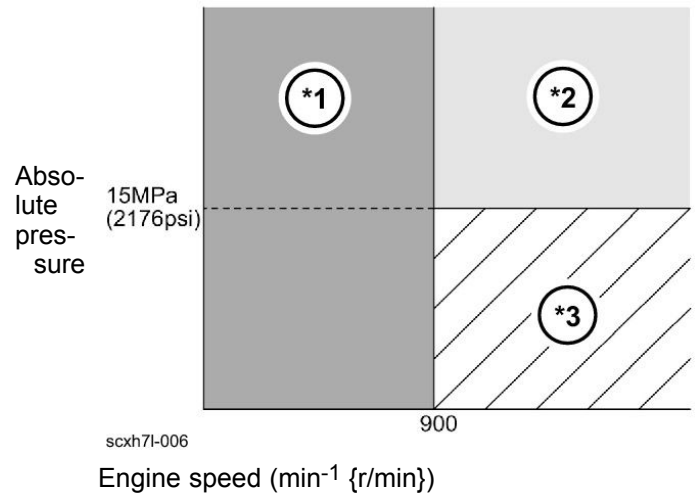

scxh7l-006

*1	Non-criteria range
*2	P0093 Criteria range
*3	Range in P0093 is established

Abnormalities of the common rail such as the flow damper, operation of the pressure limiter, or inside sealing degradation  
 Abnormalities of the injector, no fuel injection  
 System down due to failure  
 Engine body abnormalities such as seizure, insufficient compression pressure, and other mechanical failures, etc.

ACG failure

Failure related to the actual unit equipment such as the oil pressure pump, etc.

Effect of the post-installed accessories such as wireless devices and lights, etc.

ECM failure

Inspect the connector for connection failures and the harness for abnormalities such as abrasions, bending, etc.

Inspect to see if the wires inside the harness are separate and have not caused a short circuit with other circuits.

Perform inspections for functional diagnosis, and confirm the operation, control of each part, etc.

Repair if abnormalities are found.

## Engine stalling

1. Engine stalling Description of Symptom  
 Engine cranks but takes a long time to start. The engine ultimately operates, or starts but stops soon.
2. Engine stalling Diagnostics
  - Preliminary inspection  
 Before using this section, perform the functional inspection and OBD system check to check all of the following.  
 Check whether the actual unit has a significant load.  
 The ECM and monitor are operating correctly.  
 Since the crankshaft position sensor abnormalities will not be diagnosed with cranking less than

# Functional Inspection

---

## Inspection of the exhaust system

1. Exhaust system check Description of Function  
The exhaust system is comprised of the exhaust pipe, tail pipe, etc.
2. Exhaust system check Inspection  
Inspection when there is a possibility that there is an abnormality in the exhaust system
  - 1) Inspect the exhaust pipe and tail pipe.
    - No collapsing, damage, or exhaust leakage should be found.
  - 2) Repair or replace if a problem is discovered.
  - 3) Repair the actual unit.

## Inspection of the EGR control system

1. EGR control system check Description of Function  
The ECM controls the EGR valve based on the engine revolution speed, engine coolant temperature, intake air temperature, fuel injection amount, and atmospheric pressure.  
The EGR valve is driven by the EGR motor, and the EGR valve opening is detected by the EGR position sensor.
2. EGR control system check Inspection  
Inspection when there is a possibility that there is an abnormality in the locations relating to the EGR.
  - 1) Check the DTC.  
**ANNOTATION:**
    - If the DTC is detected, inspect the corresponding DTC.
  - 2) Start the engine and warm it up until the coolant temperature exceeds the standard value.  
Specified value: 70 °C { 158 °F }
  - 3) Check the EGR position display using a trouble diagnosis scan tool.  
Standard value: (-3) - 3 %
  - 4) Perform the actuator test EGR control using a trouble diagnosis scan tool if the EGR position display is outside the standard value.
  - 5) Execute an Up and Down command to the EGR valve and check the EGR position display.  
Standard value: (-3) - 3 %
  - 6) Inspect the EGR piping if the EGR position display is outside the standard value.  
No damage or gas leaks should be found.
  - 7) Repair or replace if a problem is discovered.
  - 8) Start the engine and warm it up until the coolant temperature exceeds the standard value.  
Specified value: 70 °C { 158 °F }
  - 9) Check the EGR position display using a trouble diagnosis scan tool.  
Standard value: (-3) - 3 %
  - 10) Replace the EGR valve if the EGR position display is outside the standard value.  
EGR valve Removal  
EGR valve Installation
  - 11) When replacing the EGR valve, perform EGR learning to the ECM.

# Removal and Installation of Starter Motor

4. Use a wrench (8 mm) to remove the bolt (1), and then remove the wiring (2).

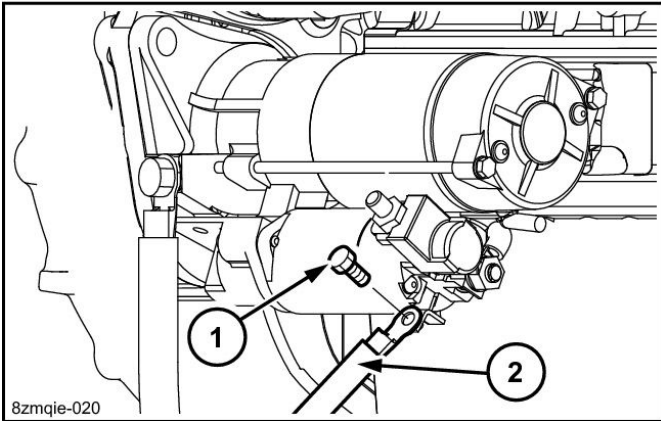

5. Use a wrench (14 mm) to remove the bolt (1), and then remove the wiring on the ground side (2).

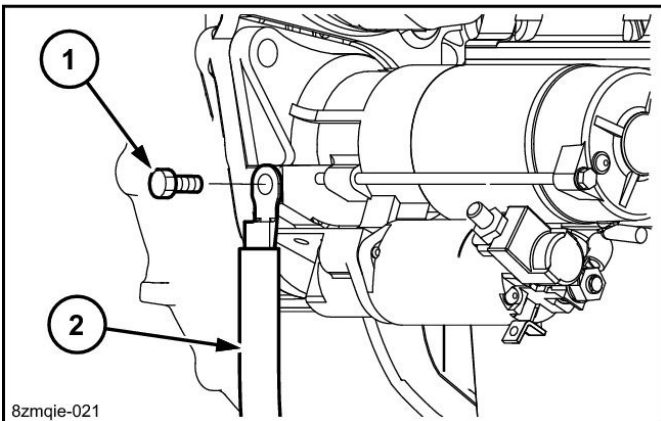

6. Use a wrench (17 mm) to remove the 2 nuts (1), and then remove the starter motor (2).

- Tightening torque for nut installation: 82.4 N·m

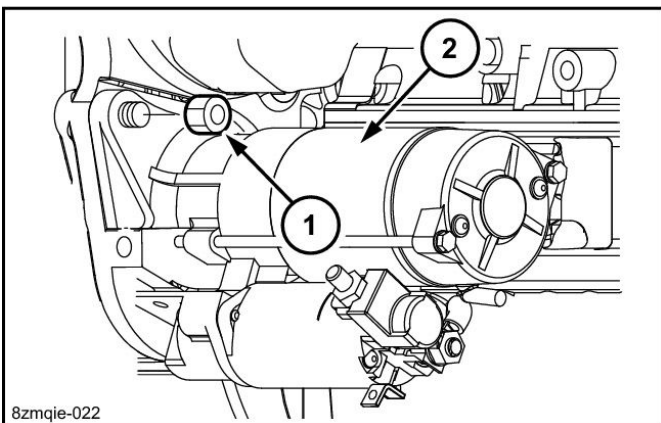

## Installation of Starter Motor

Tighten bolts and nuts to the specified torque.  
For bolts for which the torque is not specified, see "Standard Torque Data for Cap Screws and Nuts".

# Electrical Equipment Layout Diagram

## Electrical Equipment Layout Diagram

Overall View

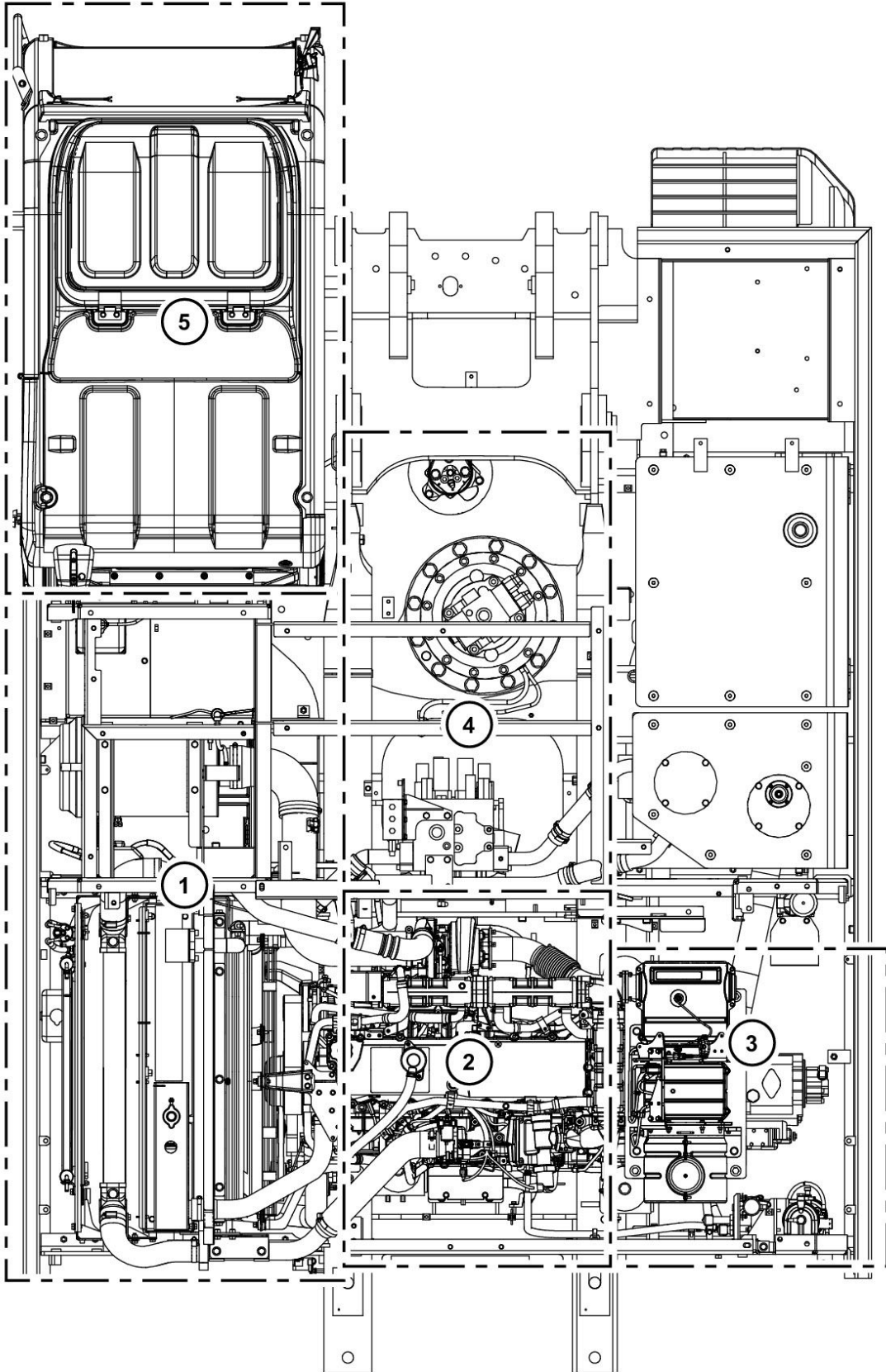

o2y3wi-002

# Electrical Equipment Layout Diagram

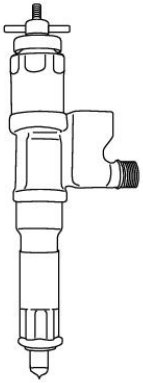
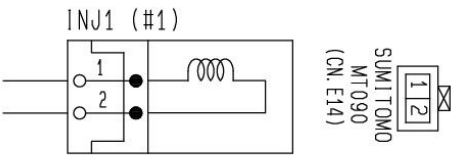
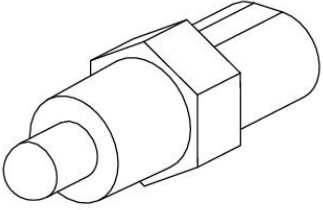
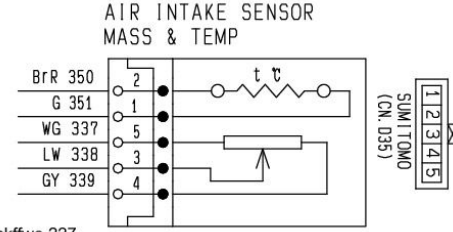
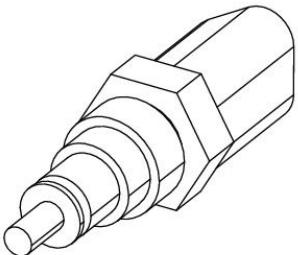
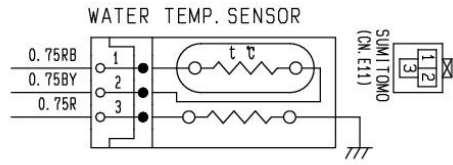
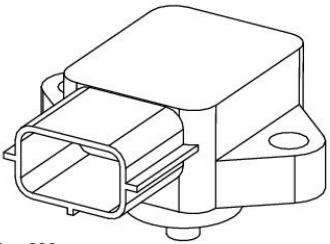
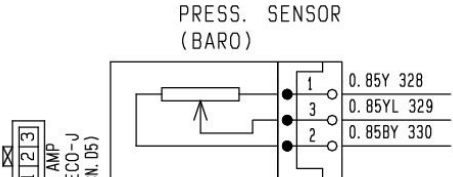
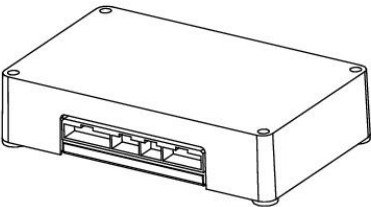
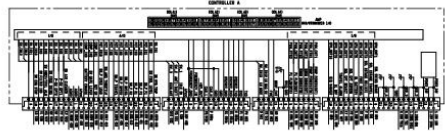
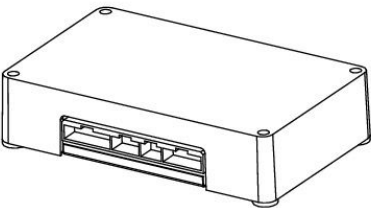
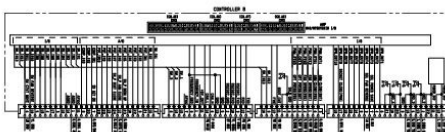
Name	Shape	Circuit	Remarks
Injector	 <p style="text-align: center;">akffwc-224</p>	 <p style="text-align: center;">akffwc-225</p>	Isuzu part No. ; 897329-7032
Suction Air Temperature Sensor	 <p style="text-align: center;">akffwc-226</p>	 <p style="text-align: center;">akffwc-227</p>	Sumitomo part No. ; KHH13270
Engine coolant temperature sensor	 <p style="text-align: center;">akffwc-228</p>	 <p style="text-align: center;">akffwc-229</p>	Isuzu part No. ; 897170-3270
Barometric pressure sensor	 <p style="text-align: center;">akffwc-230</p>	 <p style="text-align: center;">akffwc-231</p>	Sumitomo part No. ; KHH0536
Computer A	 <p style="text-align: center;">akffwc-232</p>	 <p style="text-align: center;">akffwc-233</p>	Sumitomo part No. ; KHR29000
Computer B	 <p style="text-align: center;">akffwc-232</p>	 <p style="text-align: center;">akffwc-234</p>	Sumitomo part No.;KHR29050

# Connection Connector Pin Layout

## Computer A

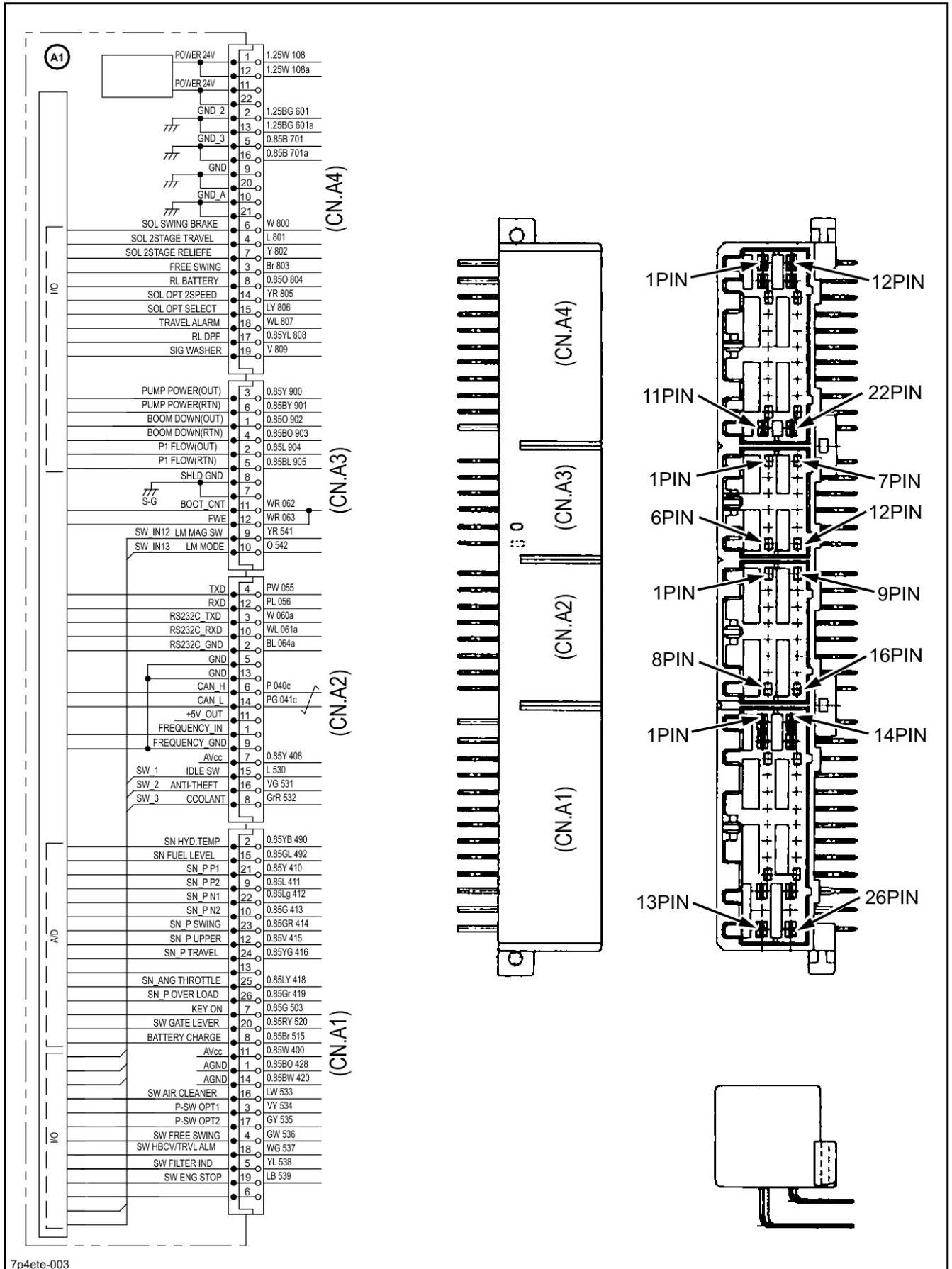

7p4ete-003



# Section

# 4021

**Engine-side DTC List**

# Introduction to the trouble diagnosis

---

The DLC is also provided to establish a connection with the scan tool.

Identification of recorded

DTC Reading the serial data

## **ANNOTATION:**

- *The installation position of the DLC and existence or nonexistence of the DLC vary depending on the actual unit, so refer to the manual of the actual unit.*

ECM OFF

Turn the ECM off starter switch off and the ECM power supply completely tops in approximately 10 seconds to disable the ECM.

General diagnostic operations of the components monitor

To run the engine normally, a general diagnosis of the components is required.

Input components

Inspect the input components to see whether an open in the circuit or outside range value exists.

Crankshaft position sensor

Camshaft position sensor

Water temperature sensor

Boost sensor

Fuel pressure sensor

Accelerator position sensor

Output components

The output components are inspected to diagnose whether responses to commands from the control unit are appropriate.

Inspect whether the circuits have disconnections and whether their values are within the range.

Suction control valve

Light, Relay control

Magnetic valve

Monitor

## 6) DTC reading procedure

Reading DTC with monitor

Current and past DTCs recorded in the ECM can be displayed by connecting the diagnostic switch and blinking the monitor.

- Switch the starter switch ON and check that the monitor shows an abnormality display.
- Turn the starter switch ON, but the engine off.
- Connect the diagnostic switch.  
For an actual unit with no diagnostic switch, short the DLC No. 1 and No. 4 or No. 5.
- Read the blinking count of the monitor.
- The DTC determines the failure contents from the diagnostic trouble code list.

If the trouble diagnostic scan tool is connected, the diagnostic codes can be read by operating the trouble diagnostic scan tool.

## **ANNOTATION:**

- *As for the installation position of the monitor, refer to the manual of the actual unit.*

Display code when no DTC is recorded

Code 1 (indicating the start of code display) continues to be displayed.

Display when a DTC is recorded

The recorded trouble codes are displayed 3 times.

If more than 2 or more trouble codes have been recorded, the DTCs will be output in ascending order with each DTC being displayed three times.

After displaying all codes, the codes will be displayed again starting with the smallest code number.

This display continues while the diagnosis connector is connected.

# Engine Control System

## Boost temperature sensor Installation

### 1. Boost temperature sensor Installation

- 1) Install the boost temperature sensor to the inlet pipe.  
Tightening torque : 13 N·m {1.3 kgf·m / 115.1 lb·in}
- 2) Connect the harness connector to the boost temperature sensor.

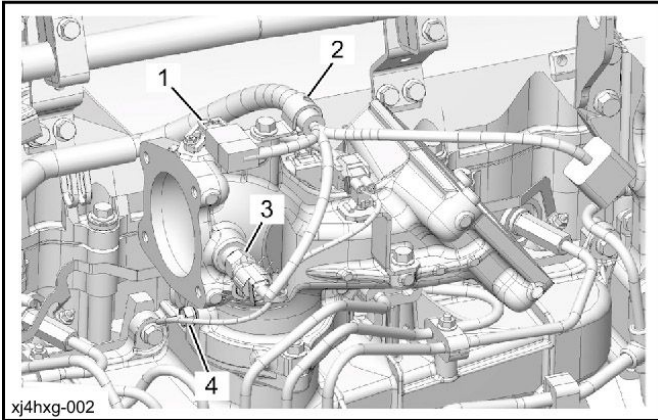

1	Boost sensor
2	Harness clip
3	Boost temperature sensor
4	IMT sensor

## Removal and Installation of IMT sensor

### IMT sensor Removal

#### 1. IMT sensor Removal

- 1) Disconnect the harness connector from the IMT sensor.
- 2) Remove the IMT sensor from the inlet pipe.

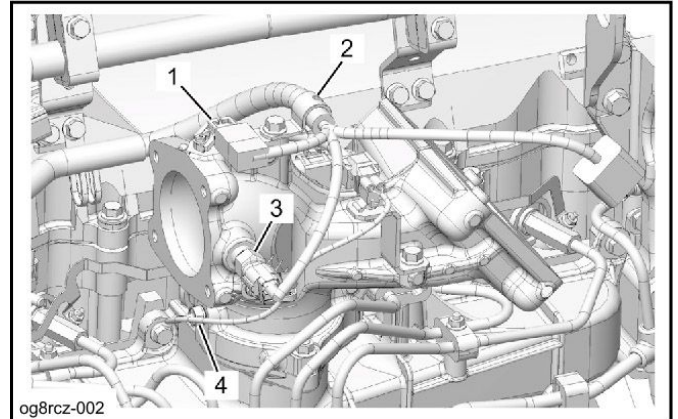

1	Boost sensor
2	Harness clip
3	Boost temperature sensor
4	IMT sensor

# Engine-side Trouble

- 
- |   |  |
|---|--|
| <p>17) If it does not turn off, inspect the Low side circuit between the ECM and suction control valve.</p> <ul style="list-style-type: none"><li>• There should be no open circuit or high resistance.</li><li>• There should be no short to the battery or ignition power supply.</li></ul> <p>18) If a problem is discovered, repair the Low side circuit.</p> <p>19) Inspect the suction control valve harness connector for a contact failure.</p> <p>20) If a problem is discovered, repair the harness connector.</p> <p>21) If the harness connector is normal, replace the suction control valve.<br/>Refer to "1.Engine 1C.Fuel System(6HK1X) Suction control valve Removal".<br/>Refer to "1.Engine 1C.Fuel System(6HK1X) Suction control valve Installation".</p> <p>22) Inspect the ECM harness connector for a contact failure.</p> <p>23) If a problem is discovered, repair the harness connector.</p> <p>24) If the harness connector is normal, replace the ECM.<br/>Refer to "1.Engine 1J.Electrical(6HK1X) ECM Removal".<br/>Refer to "1.Engine 1J.Electrical(6HK1X) ECM Installation".</p> <p>25) Set the injector ID code on the ECM.</p> <p>26) Perform the unit difference learning of the fuel supply pump to the ECM.</p> <p>2. DTC P0092 Confirm Resolution</p> <ol style="list-style-type: none"><li>1) Clear the DTC using the trouble diagnosis scan tool.</li><li>2) Turn the starter switch OFF for 30 seconds or longer.</li><li>3) Start the engine.</li><li>4) Perform a test-run.</li><li>5) Use the trouble diagnosis scan tool to confirm that a DTC has not been detected.</li></ol> | <h2>DTC P0093 (Flash Code 227) Fuel System Leak Detected</h2> <ol style="list-style-type: none"><li>1. DTC P0093 Priority DTC<br/>DTC P0087<br/>DTC P0091<br/>DTC P0092<br/>DTC P0192<br/>DTC P0193<br/>DTC P0201<br/>DTC P0202<br/>DTC P0203<br/>DTC P0204<br/>DTC P0205<br/>DTC P0206<br/>DTC P2146<br/>DTC P2149</li><li>2. DTC P0093 Diagnostics<ol style="list-style-type: none"><li>1) Inspect for fuel leaks on the high-pressure side between the fuel supply pump and injector.<ul style="list-style-type: none"><li>• There should be no fuel leakage from the fuel supply pump.</li><li>• There should be no fuel leakage from the common rail.</li><li>• There should be no fuel leakage from the pressure limiter valve.</li><li>• There should be no fuel leakage from the fuel pressure sensor.</li><li>• There should be no fuel leakage from the fuel pipe between the fuel supply pump and common rail.</li><li>• There should be no fuel leakage from the fuel pipe between the common rail and injector.</li><li>• There should be no fuel leakage from the sleeve nut of the fuel pipe.</li></ul></li><li>2) If fuel leak if found, fix the problem.<p><b>ANNOTATION:</b></p><ul style="list-style-type: none"><li>• <i>The fuel may leak to the bottom section of the cylinder head cover from the high pressure pipe inlet.</i></li><li>• <i>The engine oil level increases when the fuel leaks to the bottom portion of the cylinder head cover.</i></li><li>• <i>Inspect for fuel leaks into the engine oil.</i></li><li>• <i>Remove and inspect the high pressure pipe joint connected to the injector for a fuel leakage from the sleeve nut.</i></li><li>• <i>When foreign matter has been attached, replace the injector and the high pressure pipe.</i></li></ul></li><li>3) Remove each glow plug from the cylinder head assembly.<br/>Refer to "1.Engine 1B.Mechanical(6HK1X) Cylinder head assembly Removal".</li><li>4) Inspect for fuel leaks into the combustion chamber</li><li>5) Inspect to see if there is a cylinder from which fuel leaks into the combustion chamber.</li></ol></li></ol> |
|---|--|
-

# Engine-side Trouble

- 2) Turn the starter switch OFF for 30 seconds or longer.
- 3) Start the engine.
- 4) Perform a test-run.
- 5) Use the trouble diagnosis scan tool to confirm that a DTC has not been detected.

## DTC P0206 (Flash Code 276) Injector Circuit - Cylinder 6

### 1. DTC P0206 Diagnostics

- 1) Turn OFF the starter switch.
- 2) Disconnect the injector harness intermediate connector from the cylinder head cover case.
- 3) Measure the resistance between the sixth cylinder injector power supply terminal and the sixth cylinder injector drive signal terminal of the injector harness intermediate connector.  
Resistance : 2.0  $\Omega$
- 4) If it is at or below the standard value, inspect to see if there is an open circuit or high resistance with the circuit between the ECM and injector harness intermediate connector.
- 5) Repair the circuit if a problem is discovered.
- 6) Remove the cylinder head cover.
- 7) Inspect to see if the sixth cylinder injector harness tightening nut is loose.
- 8) If the sixth cylinder injector harness tightening nut is loose, tighten it.
- 9) Inspect to see if a foreign matter is attached to the sixth cylinder injector terminal.
- 10) If a foreign matter is attached to the sixth cylinder injector terminal, remove it.
- 11) Inspect the injector harness intermediate connector for a contact failure.
- 12) If a problem is discovered, repair the connector.
- 13) Inspect the circuit between the sixth cylinder injector and intermediate connector.
  - There should be no open circuit or high resistance.
  - There should be no short between the injector circuits.
- 14) Repair the circuit if a problem is discovered.
- 15) If the circuit is normal, replace the sixth cylinder injector.  
Refer to "1.Engine 1C.Fuel System(6HK1X) Injector Removal".  
Refer to "1.Engine 1C.Fuel System(6HK1X) Injector Installation".
- 16) When the injector has been replaced, set the injector ID code on the ECM.
- 17) Inspect the ECM harness connector for a contact failure.
- 18) If a problem is discovered, repair the harness connector.
- 19) If the harness connector is normal, replace the ECM.  
Refer to "1.Engine 1J.Electrical(6HK1X) ECM Removal".  
Refer to "1.Engine 1J.Electrical(6HK1X) ECM Installation".
- 20) Set the injector ID code on the ECM.
- 21) Perform the unit difference learning of the fuel supply pump to the ECM.

### 2. DTC P0206 Confirm Resolution

- 1) Clear the DTC using the trouble diagnosis scan tool.

# Engine-side Trouble

## DTC P1112 (Flash Code 295) Boost Temperature Sensor Circuit Low

1. DTC P1112 Priority DTC  
DTC P0651
2. DTC P1112 Diagnostics
  - 1) Turn OFF the starter switch.
  - 2) Remove the harness connector from the boost temperature sensor.
  - 3) Check the boost temperature sensor display with the trouble diagnosis scan tool.  
Voltage : 4.5 V
  - 4) If it is at or above the standard value, replace the boost temperature sensor.  
Refer to "1.Engine 1F.Induction(6HK1X) Boost temperature sensor Removal".  
Refer to "1.Engine 1F.Induction(6HK1X) Boost temperature sensor Installation".
  - 5) Inspect to see if there is a short circuit to the GND with the signal circuit between the ECM and boost temperature sensor.
  - 6) If a problem is discovered, repair the signal circuit.
  - 7) Inspect the ECM harness connector for a contact failure.
  - 8) If a problem is discovered, repair the harness connector.
  - 9) If the harness connector is normal, replace the ECM.  
Refer to "1.Engine 1J.Electrical(6HK1X) ECM Removal".  
Refer to "1.Engine 1J.Electrical(6HK1X) ECM Installation".
  - 10) Set the injector ID code on the ECM.
  - 11) Perform the unit difference learning of the fuel supply pump to the ECM.
3. DTC P1112 Confirm Resolution
  - 1) Clear the DTC using the trouble diagnosis scan tool.
  - 2) Turn the starter switch OFF for 30 seconds or longer.
  - 3) Start the engine.
  - 4) Perform a test-run.
  - 5) Use the trouble diagnosis scan tool to confirm that a DTC has not been detected.

## DTC P1113 (Flash Code 295) Boost Temperature Sensor Circuit High

1. DTC P1113 Priority DTC  
DTC P0651
  2. DTC P1113 Diagnostics
    - 1) Turn OFF the starter switch.
    - 2) Remove the harness connector from the boost temperature sensor.
    - 3) Turn ON the starter switch.
    - 4) Measure the voltage between the boost temperature sensor signal circuit and a normal GND.  
Voltage : 5.5 V
    - 5) If it is at or above the standard value, inspect to see if there is a short circuit to the battery or ignition power supply with the signal circuit between the ECM and the boost temperature sensor.
    - 6) If a problem is discovered, repair the signal circuit.
    - 7) Connect the test cable with fuse between the boost temperature sensor signal circuit and GND circuit.
    - 8) Check the boost temperature sensor display with the trouble diagnosis scan tool.  
Voltage : 0.1 V
    - 9) If it is at or below the standard value, inspect to see if there is a short circuit to the 5 V power supply circuit with the signal circuit between the ECM and the boost temperature sensor.
    - 10) If a problem is discovered, repair the signal circuit.
    - 11) Inspect boost temperature sensor harness connector for a contact failure.
    - 12) If a problem is discovered, repair the harness connector.
    - 13) If the harness connector is normal, replace the boost temperature sensor.  
Refer to "1.Engine 1F.Induction(6HK1X) Boost temperature sensor Removal".  
Refer to "1.Engine 1F.Induction(6HK1X) Boost temperature sensor Installation".
    - 14) Connect the test cable with fuse between the boost temperature sensor signal circuit and a normal GND.
    - 15) Check the boost temperature sensor display with the trouble diagnosis scan tool.  
Voltage : 0.1 V
    - 16) If it is at or below the standard value, inspect to see if there is an open circuit or high resistance with the GND circuit between the ECM and the boost temperature sensor.
- ANNOTATION:**
- The boost temperature sensor shares the GND circuit with other sensors.
  - The DTC set on a sensor which shares this circuit may be detected.
- 17) If a problem is discovered, repair the GND circuit.

# Engine-side Trouble

## DTC P042D (Flash Code 49) Catalyst Temperature Sensor Circuit High Sensor 2

1. DTC P042D Priority DTC  
DTC P0697
2. DTC P042D Diagnostics
  - 1) Turn OFF the starter switch.
  - 2) Disconnect the harness connector from the exhaust gas temperature sensor 2.
  - 3) Turn ON the starter switch.
  - 4) Measure the voltage between the exhaust gas temperature sensor 2 signal circuit and normal GND.  
Voltage : 5.5 V
  - 5) If it is at or above the standard value, inspect to see if there is a short circuit to the battery or ignition power supply with the signal circuit between the ECM and the exhaust gas temperature sensor 2.
  - 6) If a problem is discovered, repair the signal circuit.
  - 7) Connect the test cable with fuse between the exhaust gas temperature sensor 2 signal circuit and GND circuit.
  - 8) Check the exhaust temperature sensor (before the oxidation catalyst) display with the trouble diagnosis scan tool.  
Voltage : 0.1 V
  - 9) If it is at or below the standard value, inspect to see if there is a short circuit to the 5 V power supply circuit with the signal circuit between the ECM and the exhaust gas temperature sensor 2.
  - 10) If a problem is discovered, repair the signal circuit.
  - 11) Inspect to see if there is a contact failure with the exhaust gas temperature sensor 2 harness connector.
  - 12) If a problem is discovered, repair the harness connector.
  - 13) If the harness connector is normal, replace the exhaust gas temperature sensor 2.  
Refer to "1.Engine 1G.Exhaust(6HK1X) Exhaust gas temperature sensor Removal".  
Refer to "1.Engine 1G.Exhaust(6HK1X) Exhaust gas temperature sensor Installation".
  - 14) Connect the test cable with fuse between the exhaust gas temperature sensor 2 signal circuit and normal GND.
  - 15) Check the exhaust temperature sensor (before the oxidation catalyst) display with the trouble diagnosis scan tool.  
Voltage : 0.1 V
  - 16) If it is at or above the standard value, inspect to see if there is an open circuit or high resistance with the signal circuit between the ECM and the exhaust gas temperature sensor 2.
  - 17) If a problem is discovered, repair the signal circuit.
  - 18) Inspect to see if there is an open circuit or high resistance in the GND circuit between the ECM and the exhaust gas temperature sensor 2.  
**ANNOTATION:**
    - The exhaust gas temperature sensor 2 shares the GND circuit with other sensors.
    - The DTC may be detected on a sensor which shares this circuit.
  - 19) If a problem is discovered, repair the GND circuit.
  - 20) Inspect the ECM harness connector for a contact failure.
  - 21) If a problem is discovered, repair the harness connector.
  - 22) If the harness connector is normal, replace the ECM.  
Refer to "1.Engine 1J.Electrical(6HK1X) ECM Removal".  
Refer to "1.Engine 1J.Electrical(6HK1X) ECM Installation".
  - 23) Set the injector ID code on the ECM.
  - 24) Perform the unit difference learning of the fuel supply pump to the ECM.
3. DTC P042D Confirm Resolution
  - 1) Clear the DTC using the trouble diagnosis scan tool.
  - 2) Turn the starter switch OFF for 30 seconds or longer.
  - 3) Start the engine, and warm it up until the coolant temperature reaches the standard value.  
Specified value : 70 °C {158 °F}
  - 4) Repeatedly rev the engine in neutral to increase the engine rpm while checking the exhaust temperature sensor (in front of the oxidation catalyst) display with the trouble diagnosis scan tool.
  - 5) Use the trouble diagnosis scan tool to confirm that the exhaust temperature sensor (before the oxidation catalyst) display does not exceed the standard value.  
Voltage : 4.8 V Engine Control (6HK1X) 1A-57
  - 6) Use the trouble diagnosis scan tool to confirm that a DTC has not been detected.

# Main Unit-side Trouble

## Diagnostic Trouble Code: 7006 Rod Pressure Sensor Signal Abnormality

Step	Action	Standard value	Yes	No
1	1. Turn the key switch ON. 2. Check whether diagnostic trouble code: 7006 is displayed. Is diagnostic trouble code: 7006 displayed?		Go to Step 2	
2	1. Inspect the connection status of each connector. 2. Check whether diagnostic trouble code: 7006 is displayed. Is diagnostic trouble code: 7006 displayed?		Go to Step 3	
3	1. Check the rod pressure sensor voltage on the service support screen. Is it 4.75 V or higher?	4.75 V or higher	Go to Step 4	When 0.25 V or lower, go to Step 7
4	Inspect for shorts to the power supply 1. Turn the key switch OFF and disconnect CN. CR10. 2. Turn the key switch ON. 3. Measure the voltage between the ground and terminal 1 of the CN. CR10 harness side. Is it about 5 V?	About 5 V	Go to Step 5	W414 or W415 harness defect (short). Replace
5	1. Measure the voltage between the ground and terminal 2 of the CN. CR10 harness side. Is it 4.75 V or lower?	4.75 V or lower	Go to Step 6	L435 harness defect (short). Replace
6	1. Measure the voltage between the ground and terminal 3 of the CN. CR10 harness side. Is it 0.25 V or lower?	0.25 V or lower	Computer B defect. Replace	BW454 or BW455 harness defect (short). Replace
7	Inspect the rod pressure sensor. 1. Turn the key switch OFF. 2. Disconnect CN. CR10. 3. Measure the resistance between terminals 1 and 3 of the CN. CR10 rod pressure sensor side. Is it about 10 kΩ?	About 10 kΩ	Go to Step 8	Rod pressure sensor defect. Replace
8	Inspect for shorts to ground and disconnections. 1. Inspect for continuity between the ground and terminal 1 of the CN. CR10 harness side. 2. Inspect for continuity between the ground and terminal 2 of the CN. CR10 harness side. Is there continuity?		W414, W415, or L435 harness defect (short). Replace	Go to Step 9
9	1. Inspect for continuity between the ground and terminal 3 of the CN. CR10 harness side. Is there continuity?		Go to Step 10	BW454 or BW455 harness defect (disconnection). Repair or replace

# Main Unit-side Trouble

(Other than breaker specifications)

Step	Action	Standard value	Yes	No
1	1. Turn the key switch ON. 2. Check whether diagnostic trouble code: 7063 is displayed. Is diagnostic trouble code: 7063 displayed?		Go to Step 2	
2	1. Inspect the connection status of each connector and ground. 2. Check whether diagnostic trouble code: 7063 is displayed. Is diagnostic trouble code: 7063 displayed?		Go to Step 3	
3	Inspect for disconnection. 1. Turn the key switch OFF and disconnect CN. D81. 2. Inspect for continuity between terminals 1 and 2 of the CN. D81 jump harness side. Is there continuity?		Go to Step 4	Jump harness defect (disconnection). Repair or replace
4	1. Inspect for continuity between the ground and terminal 1 of the CN. D81 harness side. Is there continuity?		Go to Step 5	BG652 harness defect (disconnection). Repair or replace
5	1. Turn the key switch ON. 2. Measure the voltage between the ground and terminal 2 of the CN. D81 harness side. Is it about 5 V?	About 5 V	Computer A defect. Replace	YL538 harness defect (disconnection). Repair or replace

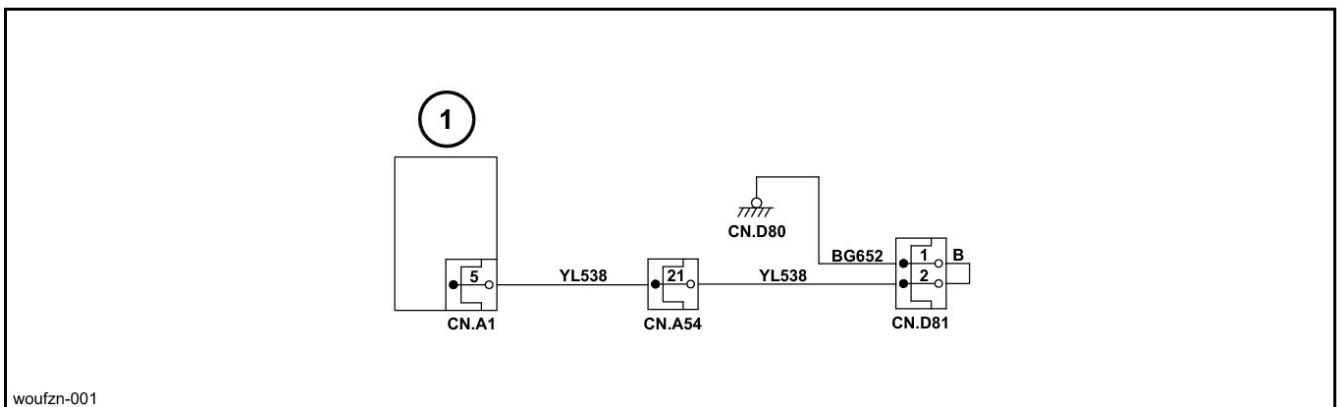

1	COMPUTER A
---	------------

CLICK HERE TO **DOWNLOAD** THE COMPLETE MANUAL

- Thank you very much for reading the preview of the manual.
- You can download the complete manual from: [www.heydownloads.com](http://www.heydownloads.com) by clicking the link below



- Please note: If there is no response to CLICKING the link, please download this PDF first and then click on it.

CLICK HERE TO **DOWNLOAD** THE COMPLETE MANUAL

# Main Unit-side Trouble

---

1	RELAY BATTERY	3	OPTION SELECT
2	FUSIBLE LINK FUSE BOX	4	CONTROLLER A

## Main Unit-side Trouble

### Diagnostic Trouble Code: 7253 DPD Regeneration Request Output Signal Abnormality

Step	Action	Standard value	Yes	No
1	1. Turn the key switch ON. 2. Check whether diagnostic trouble code: 7253 is displayed.  Is diagnostic trouble code: 7253 displayed?		Go to Step 2	
2	1. Inspect the connection status of each connector. 2. Inspect the fusible link F (50 A) fuse and fuse box F4 (10 A) fuse to see if either is blown.  Are 1 and 2 above both OK?		Go to Step 3	
3	Inspect the DPF relay. 1. Turn the key switch OFF and disconnect CN. A10. 2. Inspect for continuity between terminals 1 and 2 of the CN. A10 DPF relay side.  Is there continuity?		Go to Step 4	DPF relay defect. Replace
4	Inspect for shorts. 1. Install CN. A10. 2. Inspect for continuity between the ground and terminal 1 of the CN. A10 harness side.  Is there continuity?		WR147, WR141, or WR140 harness defect (short). Replace	Go to Step 5
5	Inspect for disconnection. 1. Turn the key switch ON. 2. Inspect for continuity between the ground and terminal 1 of the CN. A10 harness side.  Is there continuity?		Computer A defect. Replace	WR147, WR141, WR140, or YL806 harness defect (disconnection). Repair or replace

## Main Unit-side Trouble

### Diagnostic Trouble Code: 7606 EEPROM Data Abnormality

Step	Action	Standard value	Yes	No
1	<p>1. Turn the key switch ON.</p> <p>2. On the service support DIAG screen, check whether diagnostic trouble code: 7606 (●) is displayed.</p> <p>Is diagnostic trouble code: 7606 (●) displayed?</p>		Go to Step 2	
2	<p>1. Check whether rewriting was performed on computer A before the diagnostic trouble code was displayed.</p> <p>Was rewriting performed on computer A before the diagnostic trouble code was displayed?</p>		<p>Rewriting of the computer changed the used space of the EEPROM.</p> <p>Turn the key switch OFF, and then turn the key switch ON again.</p>	Computer A defect. Replace

# Electrical Wiring Diagram

---

a Tighten together with the grease line

Code	Part name	Q'ty
1	Wire harness; Light (frame main)	1
2	Light; Working	1

CN. D66 Connect to the frame main harness

# Removal and Installation of Shoe Plate

---

# Assembly and Disassembly of Upper Roller

---

# Assembly and Disassembly of Lower Roller

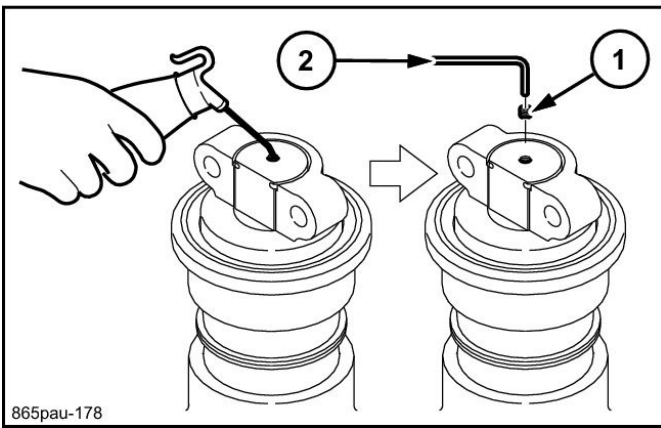

865pau-178

This completes the assembly.

# Assembly and Disassembly of Take-up Roller

## Configuration Diagram

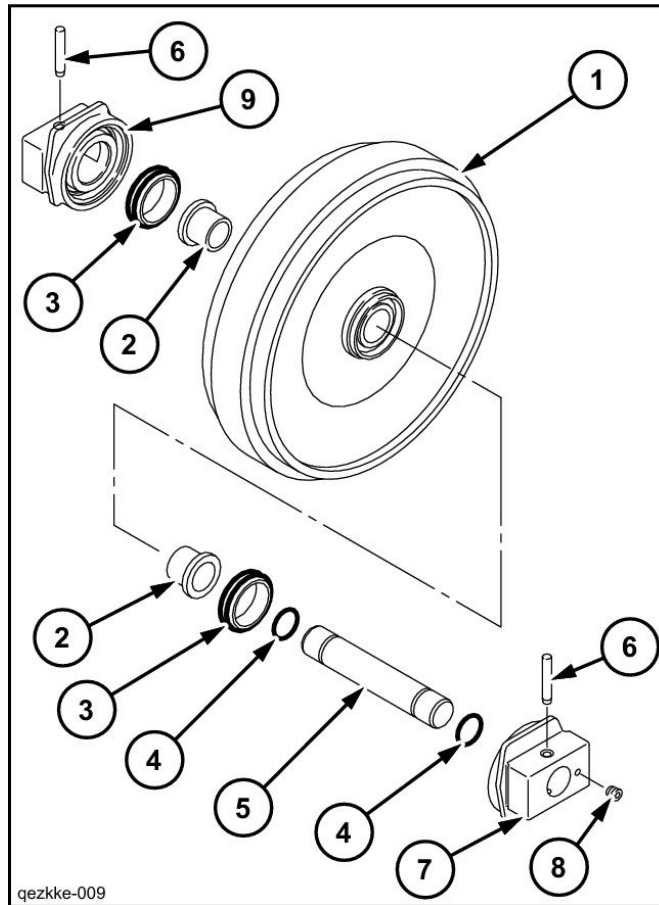

Code	Part name
1	Take-up roller
2	Wrapping bearing
3	Floating seal
4	O-ring
5	Roller shaft

Code	Part name
6	Pin hub
7	Hub (with plug)
8	Plug
9	Hub (without plug)

# Assembly and Disassembly of Grease Cylinder

## Configuration Diagram

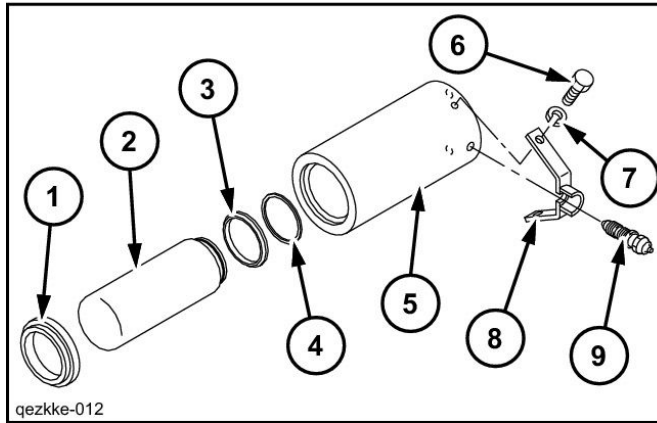

Code	Part name	Q'ty
1	Dust seal	1
2	Piston rod	1
3	U-packing	1
4	Retaining ring	1
5	Grease cylinder	1

Code	Part name	Q'ty
6	High-strength bolt	2
7	Spring washer	2
8	Bracket	1
9	Check valve assembly	1

# Assembly and Disassembly of Travel Motor

Standard tools

Secondary materials

No.	Secondary materials name	Standardized No. Manufacturer name	Type and dimensions	Part used with
1	Seal tape			
2	Adhesive	Loctite	242 515	4, 25 24
3	Gear oil	GL-4#90 equivalent		
4	Hydraulic oil	ISO VG46 equivalent		
5	Grease	Lithium series		
6	White kerosene	No.2 equivalent oil		
7	Liquid packing	ThreeBond	1211	
8	Lapping plate		For sliding surface repair	
9	Lapping agent	#1000	For sliding surface repair	
10	Copper plate			
11	Tube brush		For cleaning	
12	Bamboo brush		For cleaning	
13	Oil pan		For receiving oil	
14	Plastic container		For filling grease	
15	Rag			
16	Color check			9, 10, 11, 15, 16, 17, 18, 22, 23

Special Tool (jig)

No.	Tool name	Type and dimensions	Usage target part
1	Gear (bearing) puller		10, 51
2	Holder fittings (2)	<p>mm</p> <p>zeev9y-001</p>	13, 51
3	Rear cover guide pins (2)	<p>mm</p> <p>zeev9y-002</p>	1, 24

# Assembly and Disassembly of Travel Motor

## 2. Clearance of piston and cylinder block

### Judgment criteria and solution

- Use a micrometer caliper to measure the piston outer diameter and cylinder bore inner diameter at least 3 locations in the longitudinal direction.

Maximum outer diameter value (piston) =  $d$  maximum

Minimum outer diameter value (piston) =  $d$  minimum

Minimum inner diameter value (cylinder bore) =  $D$  minimum

Maximum inner diameter value (cylinder bore) =  $D$  maximum

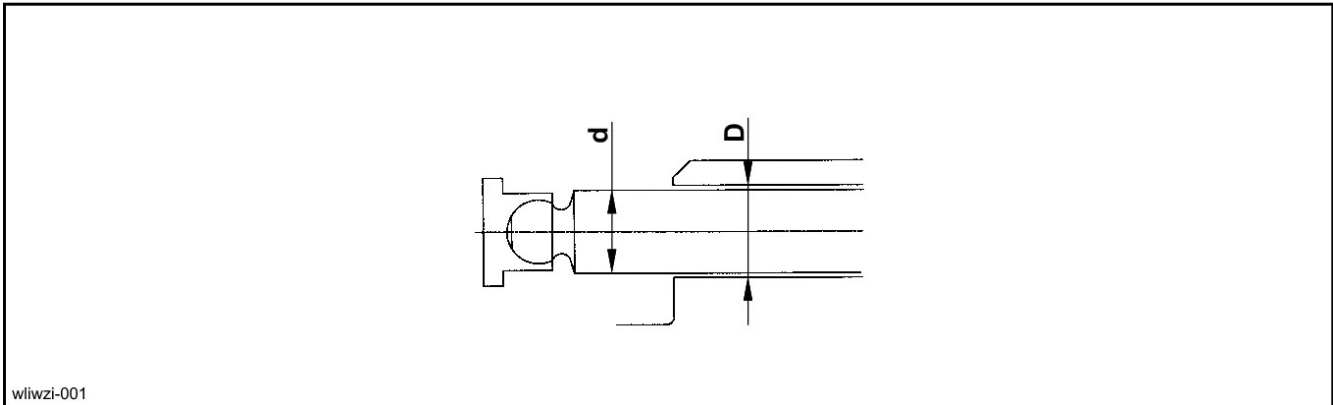

Measurement locations

Part name and inspection item	Standard value	Permissible limit value	Solution
Piston outer diameter $d$ maximum - $d$ minimum	0.01 mm	0.05 mm	Replace the piston or cylinder block.
Cylinder bore inner diameter $D$ maximum - $D$ minimum	0.01 mm	0.022 mm	
Clearance $D - d$	0.037 - 0.047 mm	0.065 mm	

(Piston replacement should be performed 9 pistons at a time.)

## 3. Piston and shoe backlash

### Judgment criteria and solution

- Use a jig (d) (See "Measurement jig") to press the shoe (e) on the surface plate, slide the pistons (c) in an upward direction, and measure the piston and shoe backlash  $\delta$ . (See "Caulking section backlash" and "Measuring backlash".)

Part name and inspection item	Standard value	Permissible limit value	Solution
Piston and shoe backlash	0 - 0.1 mm	0.3 mm	Replace piston.

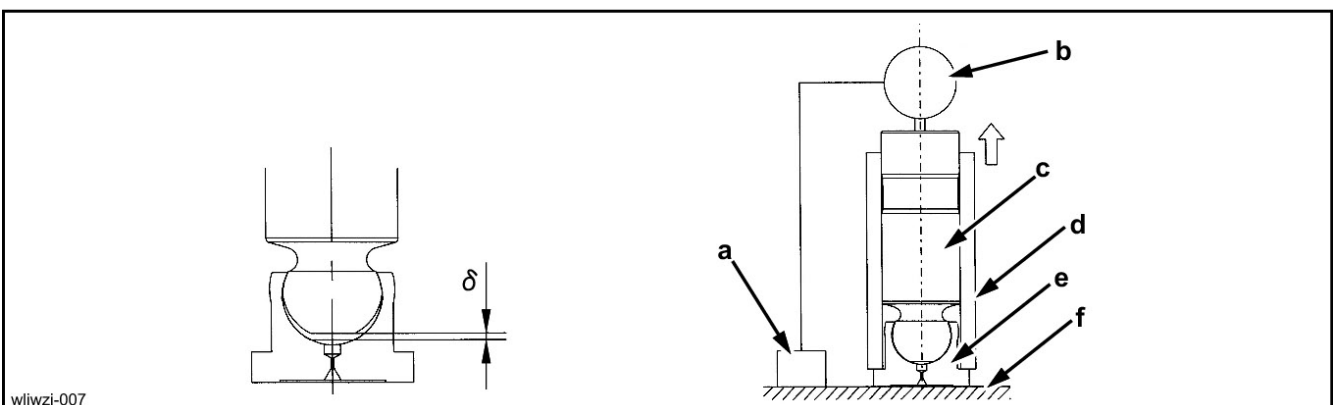

Caulking section backlash

Measuring backlash

# Assembly and Disassembly of Travel Motor

<b>Code</b>	<b>Part name</b>	<b>Code</b>	<b>Part name</b>	<b>Code</b>	<b>Part name</b>
12	Shoe plate	33	Spring receiver	54	Valve plate
13	Cylinder block	34	Spring	55	Brake spring
14	Cylinder spring	35	Pilot valve plug G3/8	56	Hexagon socket head bolt M18 x 50
15	Spring receiver	36	O-ring 1B P14	57	Overload valve
16	Spherical joint	37	Joint	58	Coupling
17	Shoe retainer	38	G1/4 plug	59	C retainer ring 40 for hole
18	Piston assembly	39	O-ring 1B P11	60	G1/2 plug
19	Separator plate	40	Orifice (brake valve)	61	O-ring 1B P18
20	Friction plate	41	Orifice spring (brake valve)		
21	Brake piston	42	G1/8 plug		



# Section

## 8001A

Overall view

# Port Diagram

## Hydraulic Pump ( standard model )

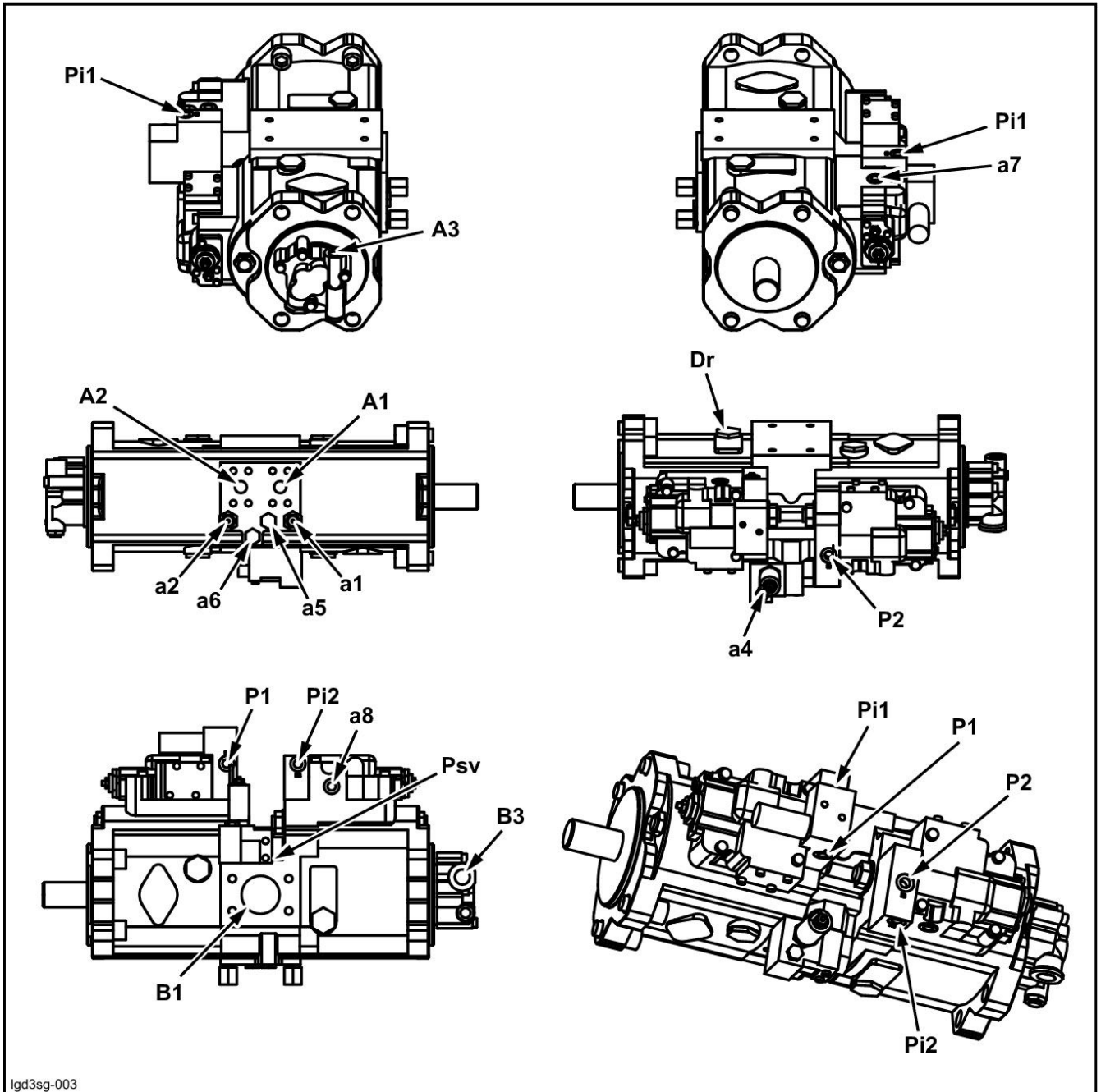

Igd3sg-003

Port	Port name	Port size	Port	Port name	Port size
A1, A2	Discharge port	SAE6000psi 3/4	Pi1, Pi2	Negative control port	G1/4-15
B1	Suction port	SAE2500psi 2-1/2	a1, a2, a4	Gauge port	G1/4-15
Dr	Drain port	G3/4-20	a5, a6	Gauge port	G3/8-17
P1	Proportional valve primary pressure port	G1/4-13	a7, a8	Gauge port	G1/4-15
P2	P2 port	G1/4-13	A3	Gear pump discharge port	G1/2-19
Psv	Servo assist port	G1/4-15	B3	Gear pump suction port	G3/4-20



# Section

# 8001D

## Pressure Measurement and Adjustment Procedures

# Pressure Measurement and Adjustment Procedures

## Pressure Adjustment

### Main Pressure Adjustment

### Main Relief Pressure Adjustment

Engine speed	1900 min <sup>-1</sup>
Work mode	SP mode
Lever operation	Arm-in relief
Oil temperature	45 - 55°C
Measuring port	P1 port

Measurement pressure	Boosted pressure: 37.3 MPa
	Standard: 34.3 MPa
Pressure per rotation of adjusting screw	Boosted pressure: 28.4 MPa/rotation
	Standard: 21.3 MPa/rotation

Remove the pilot hose for the pressure boost signal (2) connected to the main relief valve (1), then install the plug (3) into the hose side.

The procedures for boosted pressure and standard pressure are different.

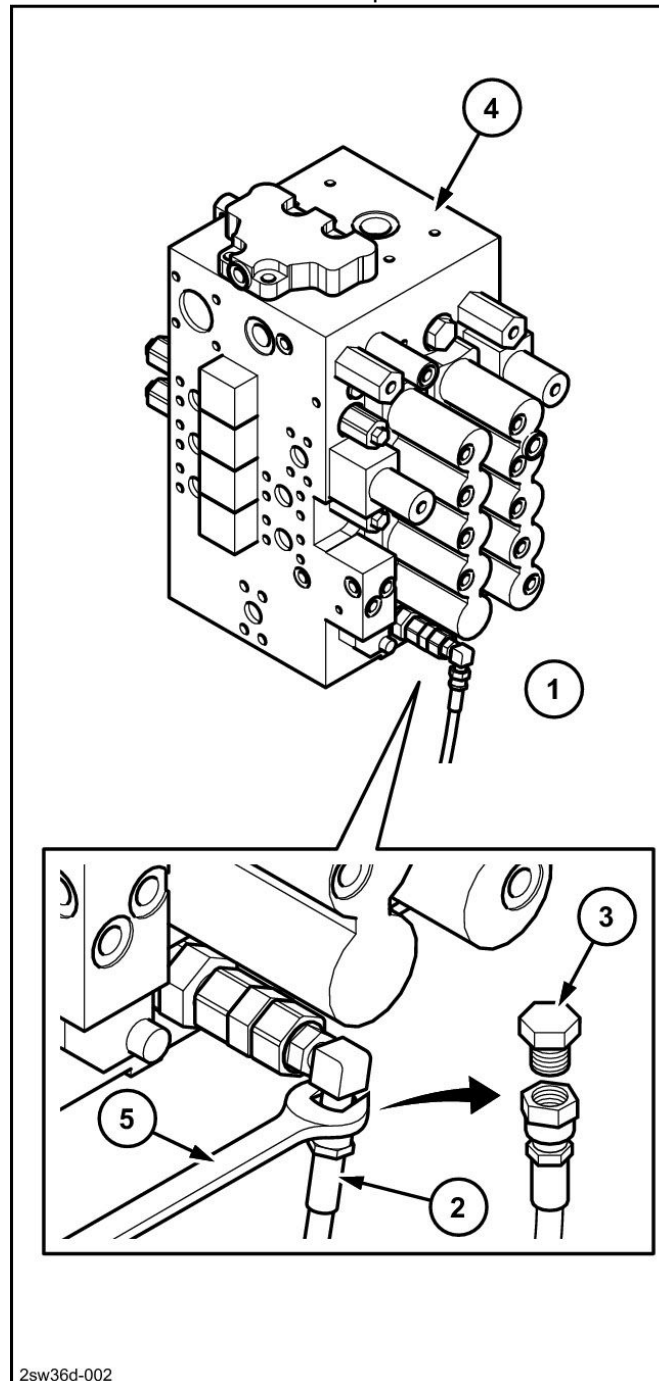

4	Control valve
5	Wrench (19 mm)

# Drain Volume Measurement Procedures

## Preparations

Measuring conditions

Engine speed	1900 min <sup>-1</sup>
Mode	SP mode
Oil temperature	About 50°C

\* Be careful.

The drain volume varies greatly with the oil temperature.

## Travel Motor Drain Volume Measurement

1. Allow the bucket (2) to touch the ground so as to elevate one shoe crawler (1) as in the diagram on the right.

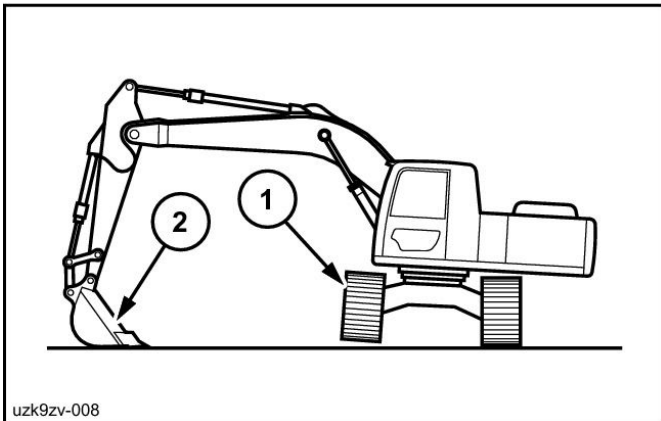

2. Remove the bolts (2), then remove the cover (1).

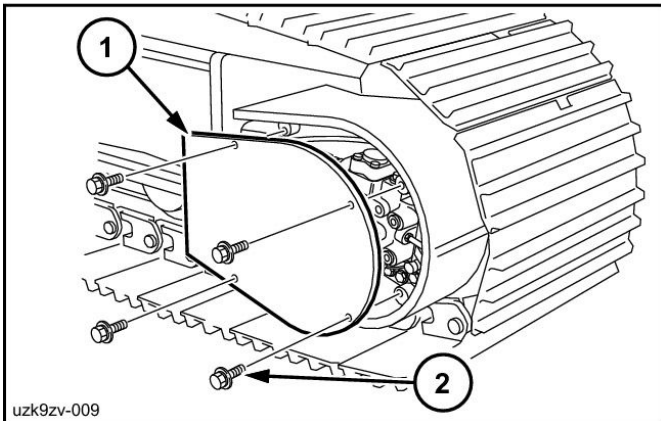

3. Always lay a rag (2) underneath before removing the drain hose (1).

4. Use a wrench to remove the drain hose (5). (Always install a cap on the removed drain hose (5).)

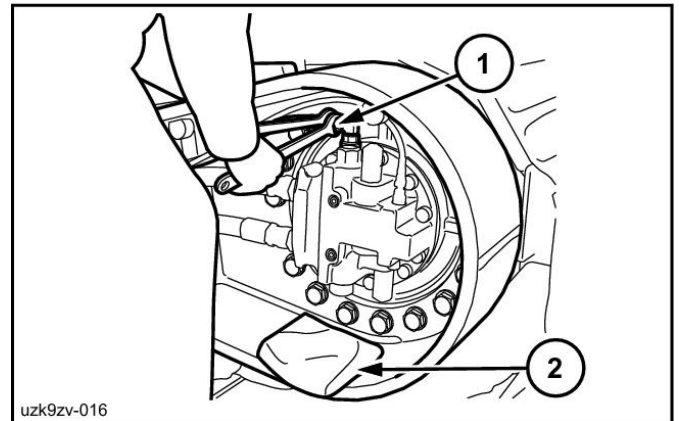

5. Install the extension hose for measurement (1) on the side of the motor from which the drain hose was removed.

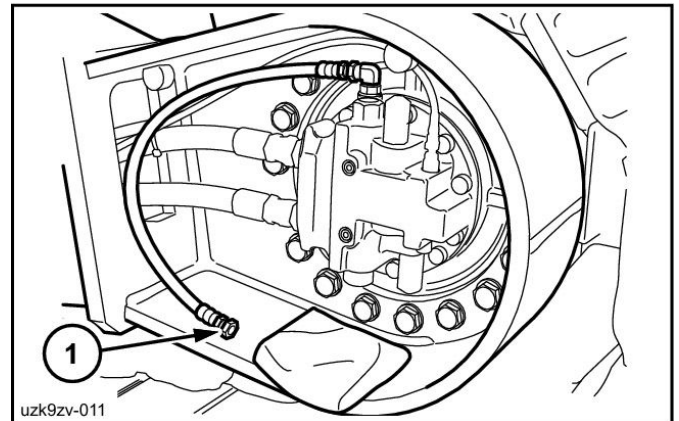

6. Prepare a waste oil can (1) and measuring container (2) and set them as in the diagram on the right.

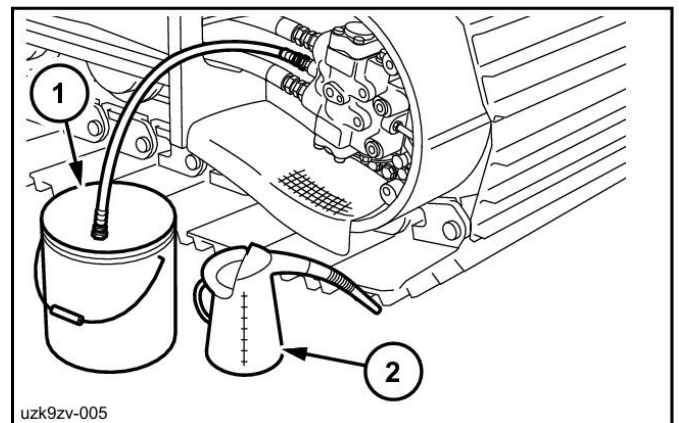

# Removal and Installation of Hydraulic Oil Tank

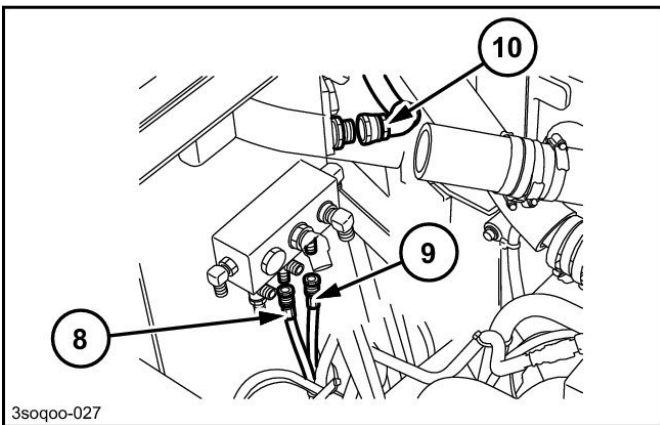

1	Drain hose (use 27 mm wrench)
2	Drain hose (use 22 mm wrench)
3	Drain hose (use 22 mm wrench)
4	Drain hose (use 19 mm wrench)
5	Drain hose (use 19 mm wrench)
6	Drain hose (use 19 mm wrench)
7	Drain hose (use 19 mm wrench)
8	Drain hose (use 19 mm wrench)
9	Drain hose (use 22 mm wrench)
10	Pump drain hose (use 36 mm wrench)

8. Cut the hose bands on the tank side, and tie the hoses together.

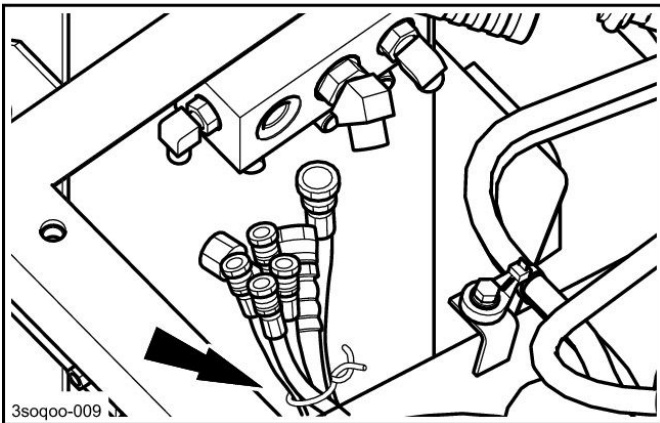

9. Use a wrench (19 mm) to remove the 7 bolts (1), and then remove the top cover (2) from the hydraulic oil tank.

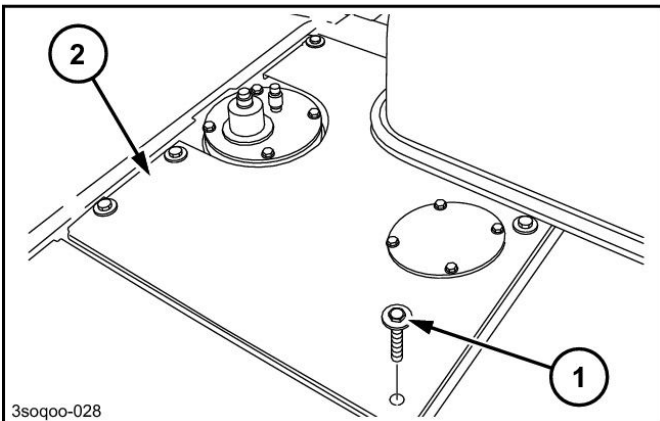

10. Use a wrench (19 mm) to remove the 3 bolts (1) for the L-shaped frame (2) between the control valve and the hydraulic oil tank, and then remove the L-shaped frame.

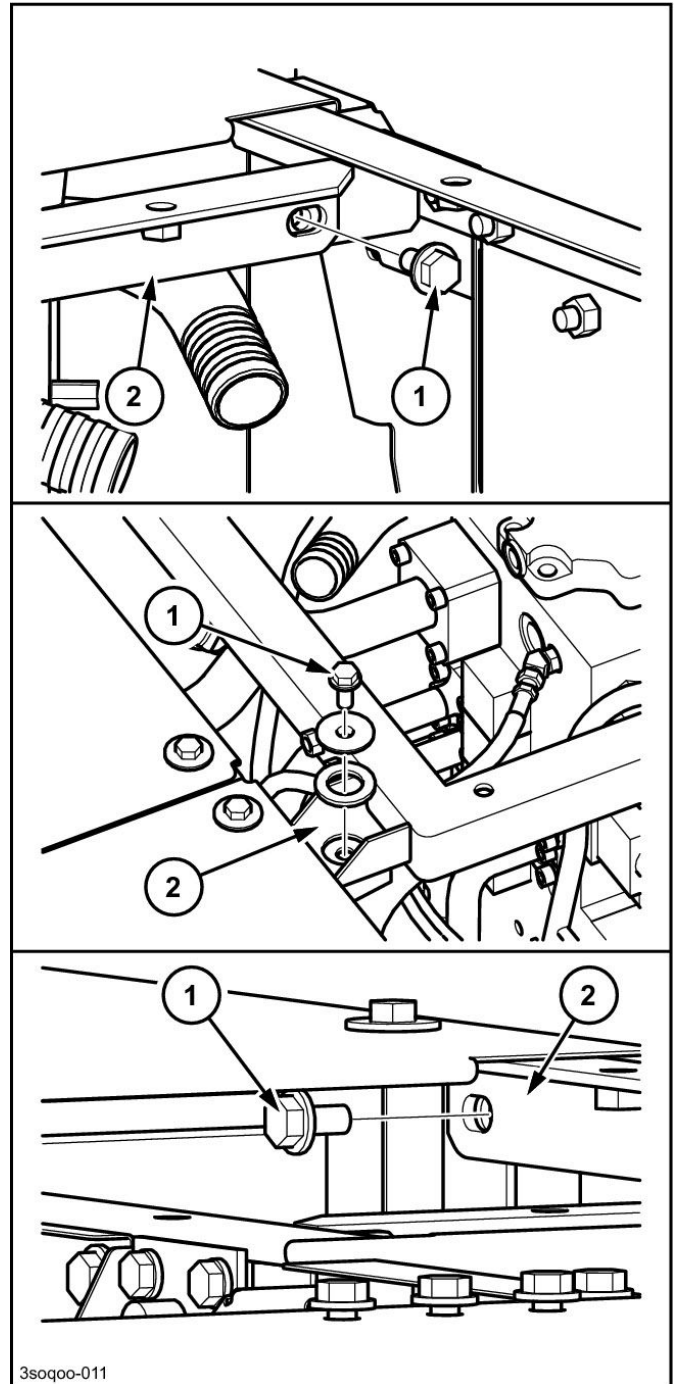

# Removal and Installation of Control Valve

6. Use a wrench (7 mm) to remove the hose band (2), then remove the low-pressure hose (1).



7. Use a wrench (17 mm) to remove the 2 bolts (1), then remove the bracket (2).

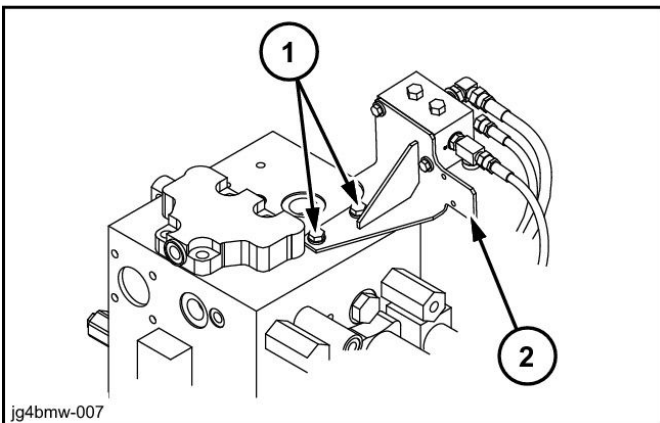

8. Use wrenches (19 mm, 22 mm) and hexagon wrenches (8 mm, 10 mm) to remove the control valve lines and hoses.

- Mark the lines and hoses so that the connectors match at the time of assembly.

- Use caps or plugs to cover the lines and hoses to prevent any entry of water, dust or dirt.
- Clean the lines by spraying with a parts cleaner to prevent scratches and prevent dirt from accumulating on the connectors.

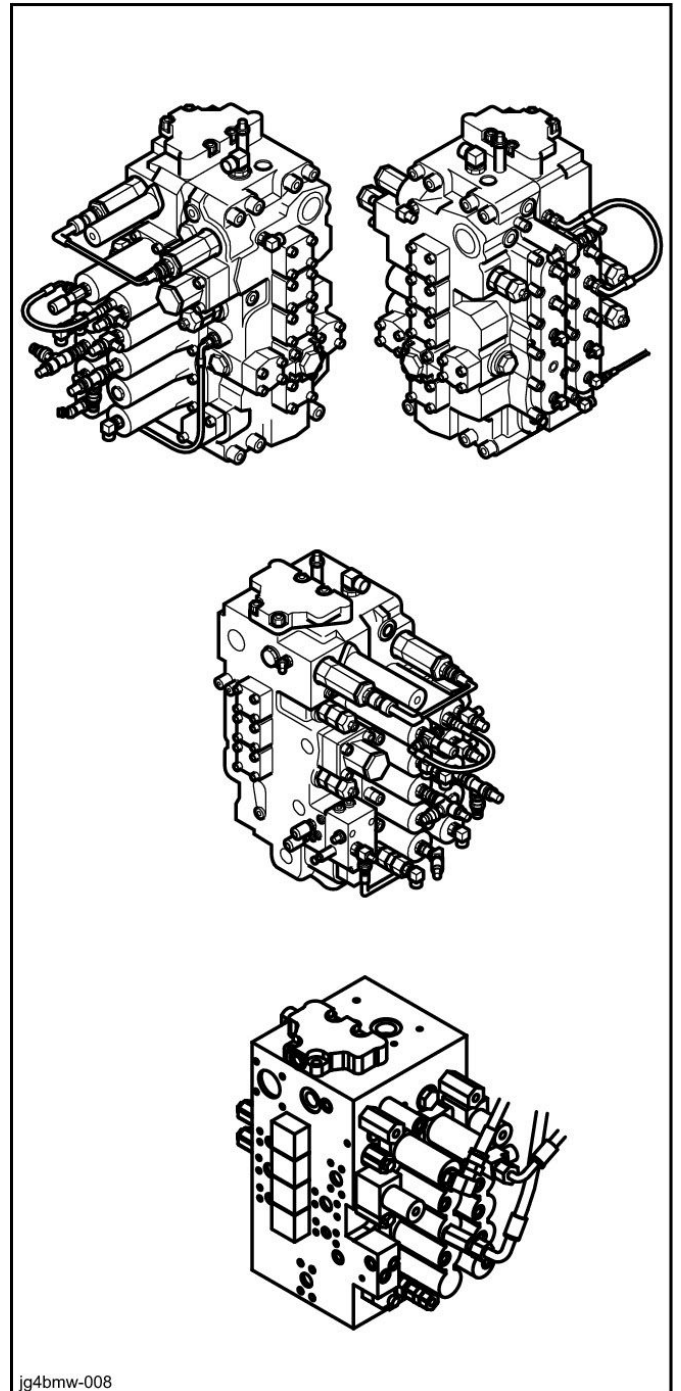

# Removal and Installation of Arm Cylinder

Job code

35737AA10

## ⚠ CAUTION

- Stop the machine on a level location with good footing.
- Be sure to stop the engine before beginning work.
- When working together with others, always be sure to exchange signals and pay adequate attention to safety.
- Always wear protective devices (protective eyewear and safety shoes, etc.) when working with a hammer.
- Be sure to inspect the nylon sling and other lifting equipment before beginning work.
- Do not stand or pass under the suspended load.

## Items to prepare

- Wrenches (19 mm, 36 mm, 41 mm)
- Nylon sling (with the required lifting capacity)
- Liftcrane (with the required lifting capacity)
- Cap
- Plug
- Hammer
- Striking rod
- Grease
- Rag
- Cleaning fluid
- Crosstie
- Wire

## Removal of Arm Cylinder

1. Use a liftcrane and nylon sling (1) to secure the arm cylinder (2).

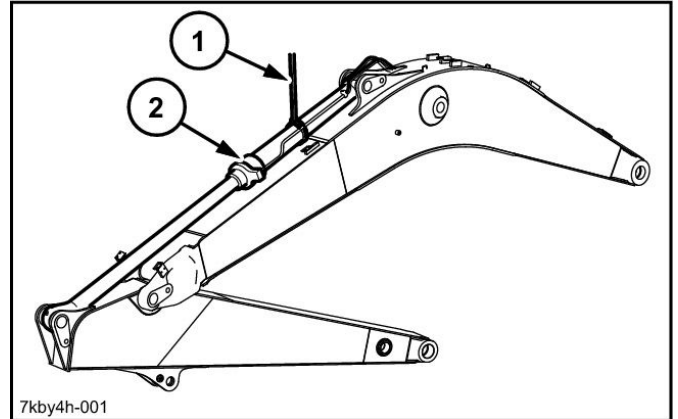

2. Use a wrench (19 mm) to remove the bolt (1) and washer (2).

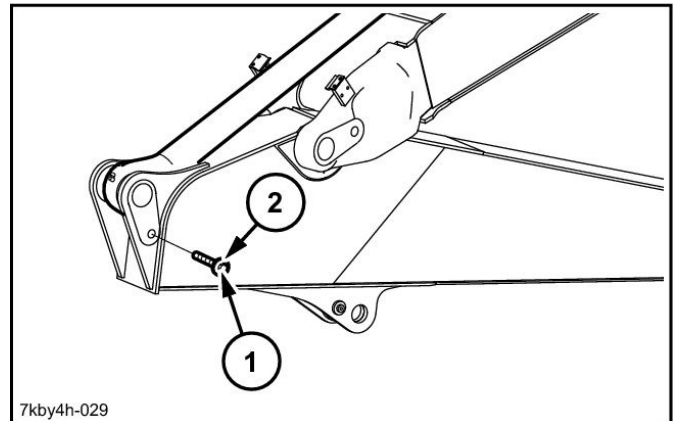

3. Use a hammer (2) and striking rod (3) to remove the pin (1). Be careful. The arm and arm cylinder rod may come out of place at this time.

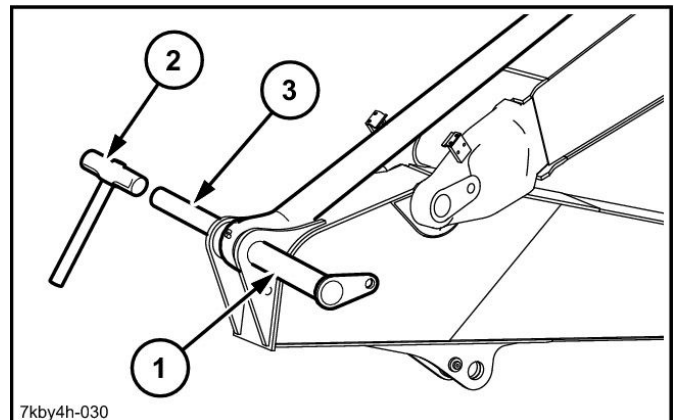

# Removal and Installation of Center Joint

## ⚠ CAUTION

- Be sure to stop the engine before beginning work.
- Be sure to inspect the wire rope and other lifting equipment before beginning work.
- Do not stand or pass under the suspended load.

### Items to prepare

- Wrenches (19 mm, 24 mm, 27 mm, 41 mm)
- Hexagon wrenches (5 mm, 8 mm)
- Box wrench (19 mm)
- Specialty adapter for vacuum pump connection
- Vacuum pump (vacuum pump power supply)
- Extension cable
- Marking pen
- Cap
- Plug
- Wire rope (with the required breaking load)
- Liftcrane (with the required lifting capacity)
- Wood planks, etc.
- Rag
- Cleaning fluid

## Removal of Center Joint

1. Use a hexagon wrench (5 mm) to remove the 4 bolts (1), and then remove the air breather (2) on the hydraulic oil tank.  
Tightening torque for bolt installation: 2.94 - 4.90 N·m

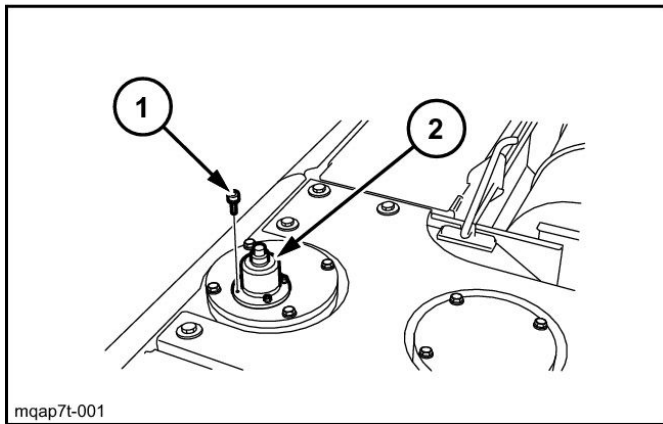

2. Install the specialty adapter (1) to the area where the air breather is removed, and set the vacuum pump (2).  
Create negative pressure in the hydraulic oil tank using the vacuum pump.

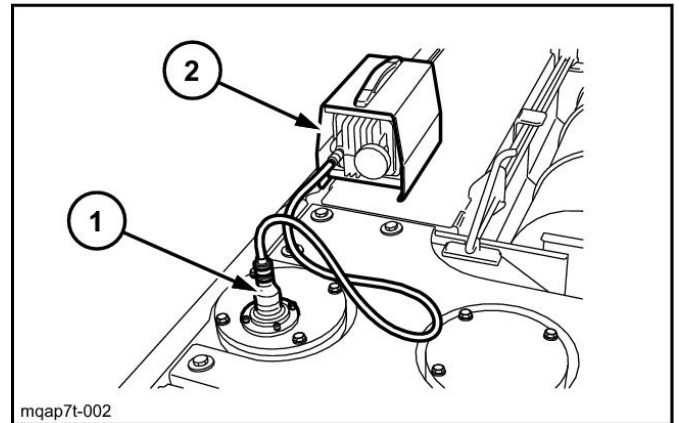

3. Use a box wrench (19 mm) to remove the 8 bolts (1), and then remove the lower under covers (2).

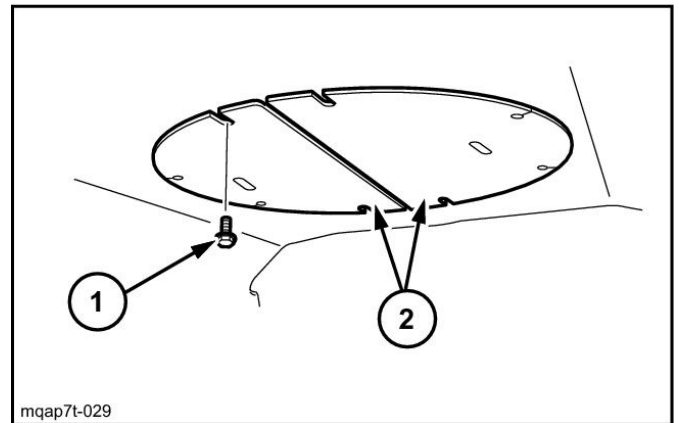

4. Prepare a waste oil can (1) to receive the oil that spills out under the center joint.

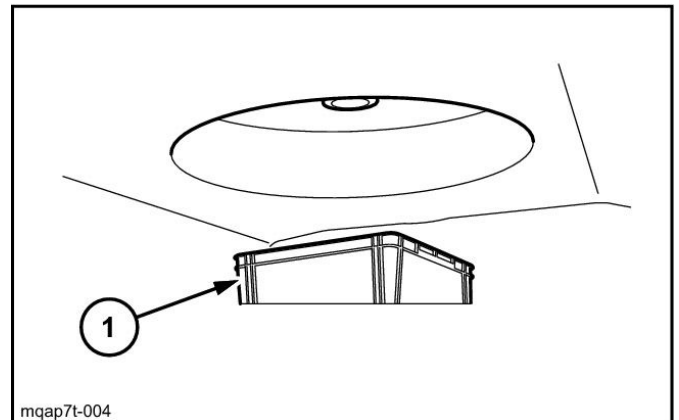

5. Use a wrench (41 mm) to remove the travel hoses (1), use a wrench (27 mm) to remove the drain hoses (2), and use a wrench (19 mm) to remove the pilot hoses (3).
  - Mark the center joint and hoses so that the connectors match at the time of assembly.
  - Install caps or plugs to the center joint and hoses to prevent any entry of water, dust or dirt.
  - Clean the center joint and hoses by spraying them with a parts cleaner to prevent scratches and prevent dirt from accumulating on the connectors.

# Removal and Installation of Operation Remote Control Valve

11. Use a hexagon wrench (5 mm) to install the 2 bolts (2), and install the grip (1) of the gate lock lever.

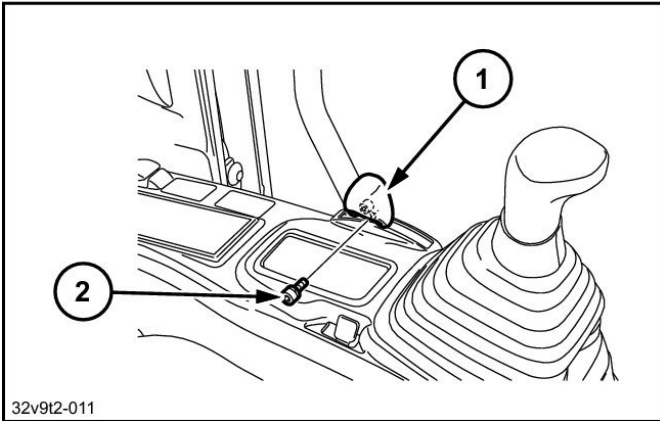

12. Use the Phillips screwdriver to install the 2 screws (2), then install the handle of the tilt lever (1).

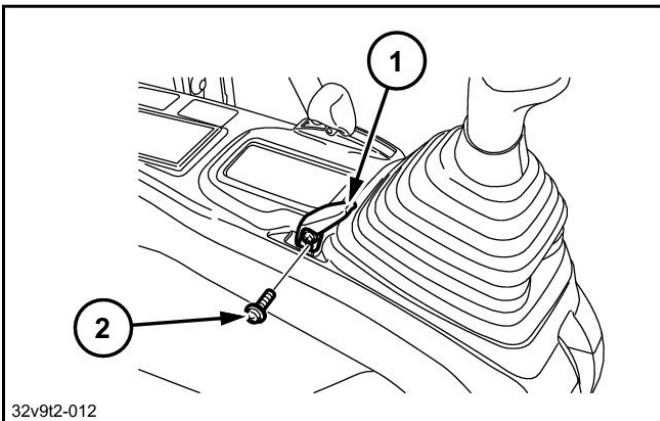

13. Use the Phillips screwdriver or box wrench (10 mm) to install the 2 bolts (2) for the console top cover and cover the control lever boot (1).

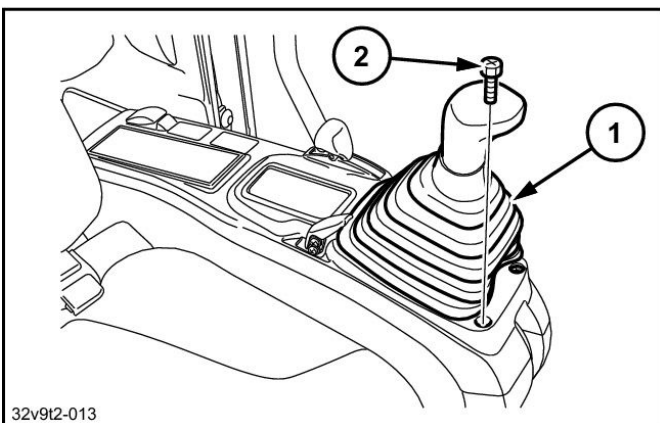

## Removal of Operation Remote Control Valve (right side)

1. Roll up the boot (1) of the control lever and use the Phillips screwdriver or box wrench (10 mm) to remove the 2 bolts (2) of the console top cover.

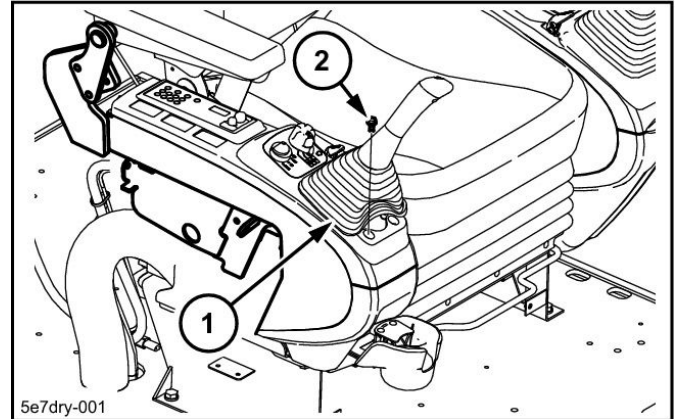

2. Use the Phillips screwdriver to remove the 2 screws (2), and then remove the handle of the tilt lever (1).

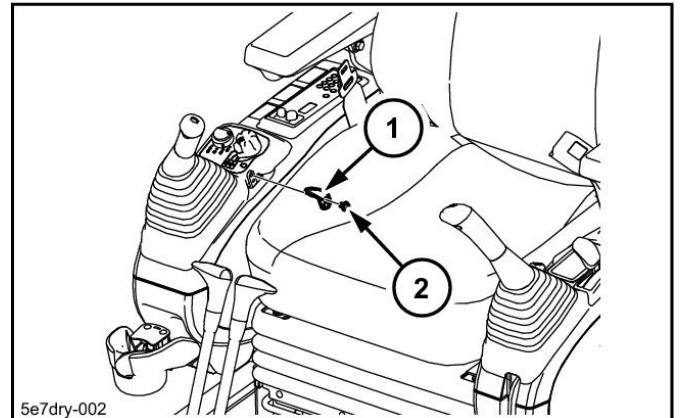

3. Use the Phillips screwdriver to remove the 2 screws (1) of the console top cover.

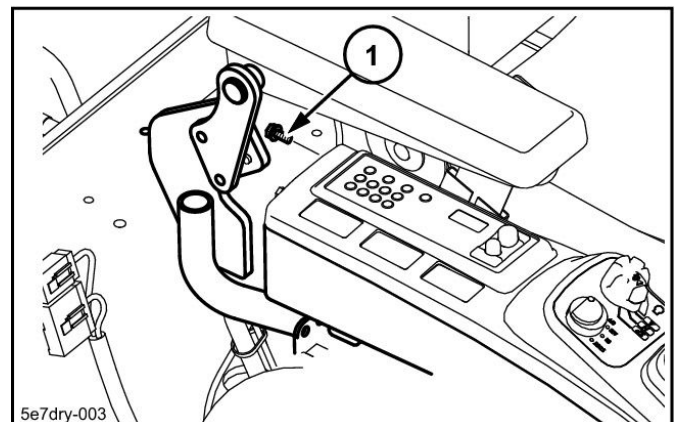

# CONTENTS

---

Removal of Cushion Valve .....	3
Installation of Cushion Valve .....	6

# CONTENTS

---

Replacement standards for worn parts .....	3
Standards for repairing cylinders, valve plates, and swash plates (shoe plates) .....	3
Tightening torque .....	4
Overall View .....	4
Attached diagram 1. pump assembly cross-section diagram .....	4
Drive Shaft Front Side .....	5
Drive Shaft Rear Side .....	6
Part Table .....	7
Procedures for Assembly and Disassembly of Regulator .....	9
Tools .....	9
Disassembly preparations .....	9
Disassembly procedures .....	10
Assembly procedures .....	12

# Procedures for Assembly and Disassembly of Control Valve

## Disassembly of arm regeneration release valve section

Sub-parts in the assembly are expressed as [main number - sub-number].

### ⚠ CAUTION

- 1. When removing the plug, pressure left within can make parts fly out dangerously.**
- 2. Slowly loosen the plug to check that there is no resistance due to residual pressure, then disassemble.**

1. Loosen and remove the plug (24) (32 mm hexagon diameter) and remove the O-ring (25).
2. Remove the spring (26) and spool (27-1) from the sleeve (27-2).
3. Pull out the sleeve (27-2) from the valve housing.
4. Remove the piston (27-3), O-ring (30), and backup ring (31) from the sleeve (27-2).

## Disassembly of load check valve section

### ⚠ CAUTION

- 1. When removing the plug, pressure left within can make parts fly out dangerously.**
- 2. Slowly loosen the plug to check that there is no resistance due to residual pressure, then disassemble.**

1. Loosen and remove the hexagon socket head bolts (75) (4 in each section, 8 mm hexagon socket diameter) for the flanges (37) (6 locations) and (61) (1 location).  
Only (61) has a different shape from the others, so keep it separate from (37).
2. Remove the spring (35), poppets (34) and (51) and O-ring (36) from the valve housing.  
Remove the arm 2 (E-E cross section) poppet (59), spring (60), and sleeve (58).
3. Loosen and remove the hexagon socket head bolts (75) (8 mm hexagon socket diameter) for the flanges (52) (2 locations) .
4. Remove the spacer (53) from the valve housing and remove the O-ring (54) and backup ring (55) from the spacer (53).
5. Remove the spring (35) and poppet (34) from the valve housing.
6. Loosen and remove the plug (72) (8 mm hexagon socket diameter). (D-D cross section)
7. Remove the spring (33) and poppet (32) from the valve housing.
8. Loosen and remove the plug (72) (8 mm hexagon socket diameter). (D-D cross section)
9. Remove the spacer (57), spring (33), and poppet (32) from the valve housing.
10. Loosen and remove the plug assembly (92) (36 mm hexagon diameter). (P4 section, cross section H-H )
11. Loosen and remove the hexagon socket head bolts (74) (4 locations, 8 mm hexagon socket diameter) for the flange (43) .
12. Remove the spring (45), poppet (44), and O-ring (36) from the valve housing.
13. Loosen and remove the plug (46) (27 mm hexagon diameter) and remove the O-ring (47). (H-H cross section)
14. Remove the spring (48) and poppet (49) from the valve housing.

## Disassembly of antidrift valve section

Sub-parts in the assembly are expressed as [main number - sub-number].

### ⚠ CAUTION

- 1. When removing the antidrift valve assembly, pressure left within can make seals and other parts fly out dangerously.**
- 2. Slowly loosen the hexagon socket head bolt to check that there is no resistance due to residual pressure, then disassemble.**

1. Loosen and remove the hexagon socket head bolts (74) (4 in each section, 8 mm hexagon socket diameter) for the 2 antidrift valve assemblies (67).
2. Remove the O-rings (36) and (41) from the valve housing.
3. Remove the spring (39) and poppet (38) from the valve housing.
4. Disassembly of antidrift valve assembly

# Procedures for Assembly and Disassembly of Control Valve

*1	TANK	*4	BOOM 1	*7	OPTION
*2	BOOM 2	*5	TRAVEL		
*3	UP ⇔ DOWN	*6	STRAIGHT TRAVEL		

# Procedures for Operation/Assembly and Disassembly of Hydraulic Cylinder

Item	Symptom	Related part	Cause	Countermeasure and solution
1	Piston rod sliding section oil leak	Piston rod	A sliding surface has rust and scratches that catch on a fin-gernail.	<ol style="list-style-type: none"> <li>1. Remove the scratches with a whetstone to make the sliding surface smooth (1.5 s max.). If the oil leak continues, the rod scratches may have damaged the U-ring or other seal, so disassemble and inspect.</li> <li>2. If the scratches or rust cover too large an area to be repaired with a whetstone, replace the piston rod and the U-ring, wiper ring, or other seal and the piston rod bearing part.</li> </ol>
			Plating is peeling off.	<ol style="list-style-type: none"> <li>1. Replate or replace the piston rod.</li> <li>2. At this time, inspect the seals and piston rod bearing part as well and replace any that are damaged.</li> </ol>
		Rod packing (Buffer ring and U-ring)	There is foreign matter caught in the inner or outer diameter section.	<ol style="list-style-type: none"> <li>1. Remove the foreign matter.</li> <li>2. If the packing is damaged, replace it.</li> </ol>
			There are scratches on the inner or outer diameter section.	Replace.
			The lips and groove section are locally carbonized (scorched).	<ol style="list-style-type: none"> <li>1. This may be scorching due to adiabatic compression of air remaining in the cylinder.</li> <li>2. When operating the cylinder for the first time after replacing a packing, run at low pressure and low speed to adequately bleed off the air.</li> </ol>
			The packing has lost its rubber elasticity and is in tatters.	<ol style="list-style-type: none"> <li>1. Replace.</li> <li>2. This may be the end of the packing service life, deterioration of the hydraulic oil, or high temperature of the hydraulic oil.</li> </ol>
			The lip section is defective all the way around.	<ol style="list-style-type: none"> <li>1) Replace with a new hydraulic oil.</li> <li>2) Check the temperature of the hydraulic oil.(The oil temperature should be no higher than 80°C.)</li> <li>3) Check for local high temperature.</li> </ol>
			There is major extrusion of the packing heel section.	<ol style="list-style-type: none"> <li>1. Replace.</li> <li>2. Abnormally high pressure may be operating on the packing.                             <ol style="list-style-type: none"> <li>1) Check the pressure during operation.</li> <li>2) There may be trouble with the buffer ring section. Inspect the buffer ring section.</li> </ol> </li> </ol>

# Procedures for Operation/Assembly and Disassembly of Hydraulic Cylinder

## Arm Cylinder

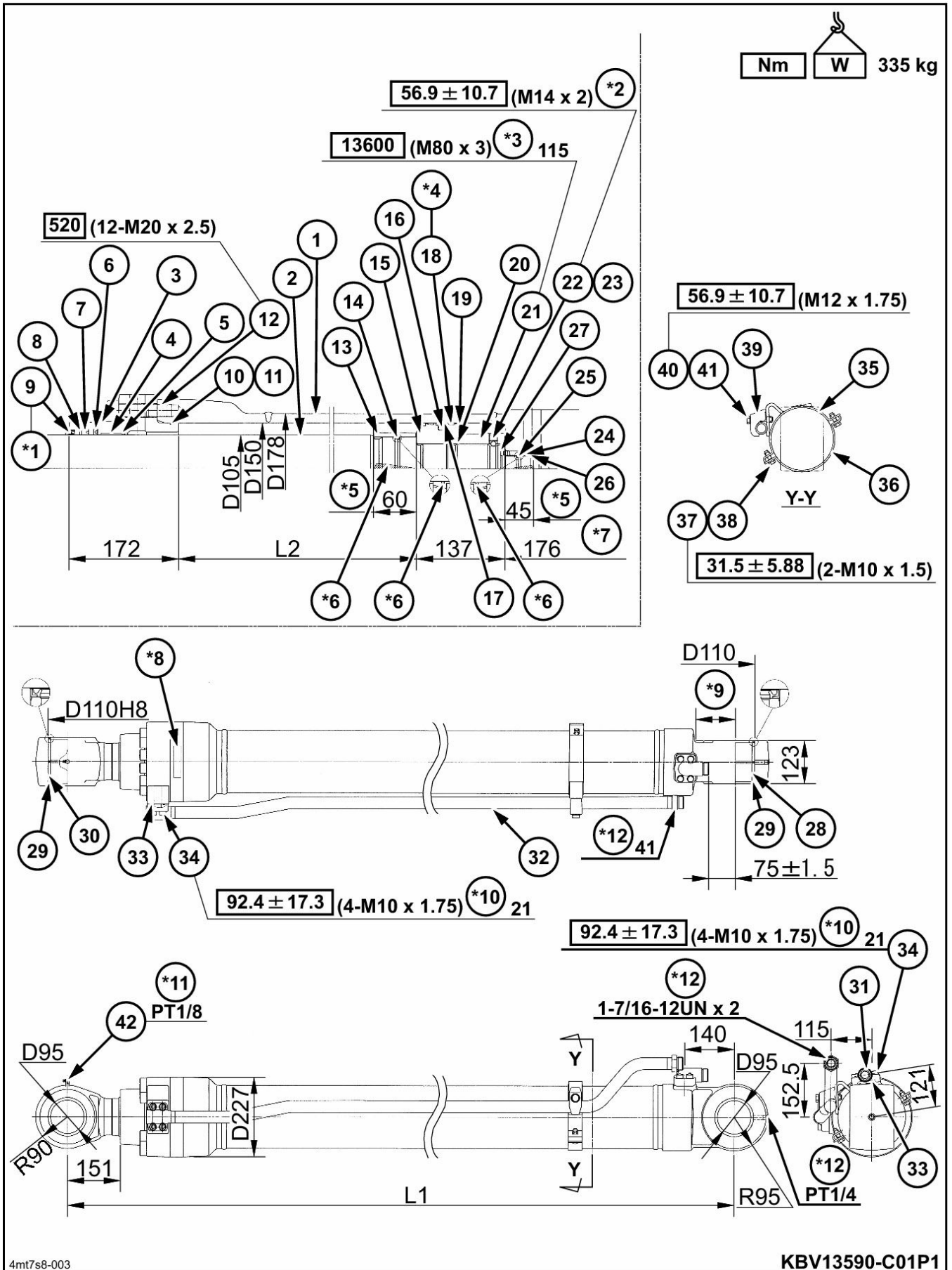

4mt7s8-003



# Section

# 8014

**Procedures for Assembly and Disassembly of Travel  
Remote Control Valve**

# CONTENTS

---

Disassembly Procedures .....	3
Reverse Operation Spool Section .....	3
Check Plunger Section with Throttle .....	3
Shuttle Valve Section .....	4
Assembly Procedures .....	5
Reverse Operation Spool Section .....	5
Check Plunger Section with Throttle .....	6
Shuttle Valve Section .....	6
Written Materials .....	7

# Removal and Installation of Boom HBCV

1	Pilot hose (use 22 mm wrench)
3	Drain hose (use 19 mm wrench)
4	Pilot hose (use 22 mm wrench)
5	Pilot hose (use 22 mm wrench)

## Installation of Boom HBCV

1. Set the O-ring (1) on the boom HBCV (2), and then install with 4 hexagon socket head bolts (3).

- The O-ring cannot be reused. Replace with a new part.

Tightening torque:  $92.4 \pm 17.5 \text{ N}\cdot\text{m}$

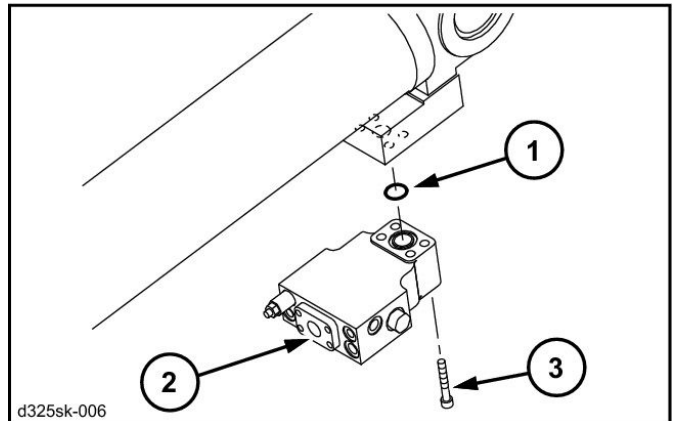

2. Set the O-ring (1) on the line (2), and then install with 4 hexagon socket head bolts (3).

- The O-ring cannot be reused. Replace with a new part.

Tightening torque:  $92.4 \pm 17.5 \text{ N}\cdot\text{m}$

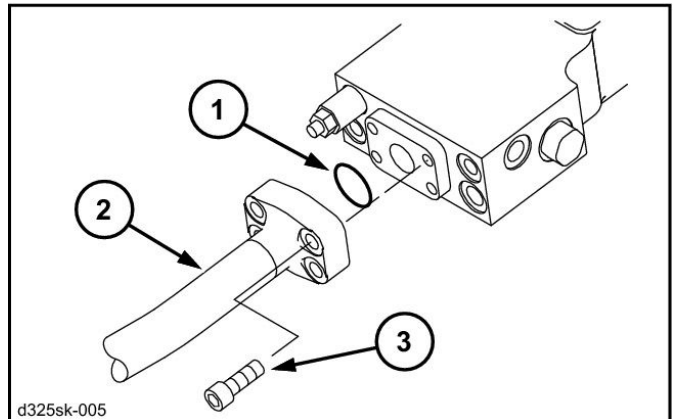

3. Use wrenches (19 mm, 22 mm) to install the hoses (1) (3) (4) (5) of the boom HBCV, and use a wrench (27 mm) to install the boom bottom pressure sensor (6).

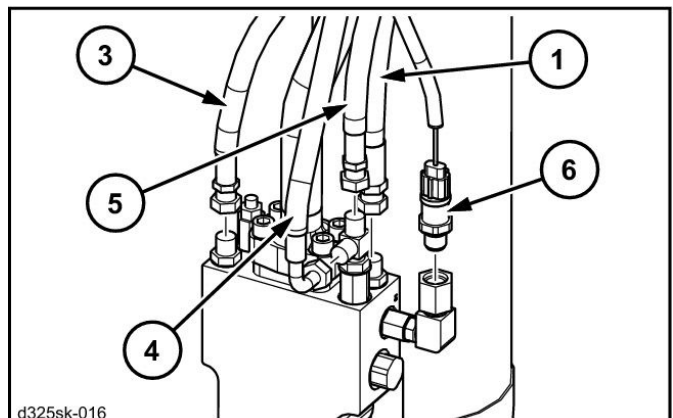

5. Use a hexagon wrench (8 mm) to remove the 4 hexagon socket head bolts (3), and then remove the line (2) and O-ring (1).

- Use caps or plugs to cover the HBCV and lines to prevent any entry of water, dust or dirt.
- Clean the HBCV and lines by spraying them with a parts cleaner to prevent scratches and prevent dirt from accumulating on the connectors.

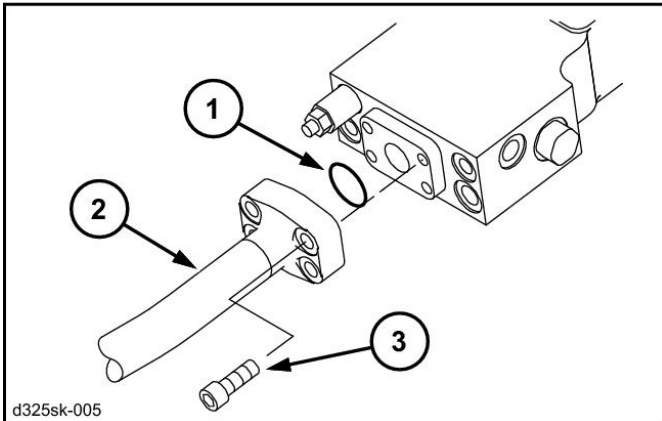

6. Use a hexagon wrench (8 mm) to remove the 4 hexagon socket head bolts (3), and then remove the boom HBCV (2) and O-ring (1).

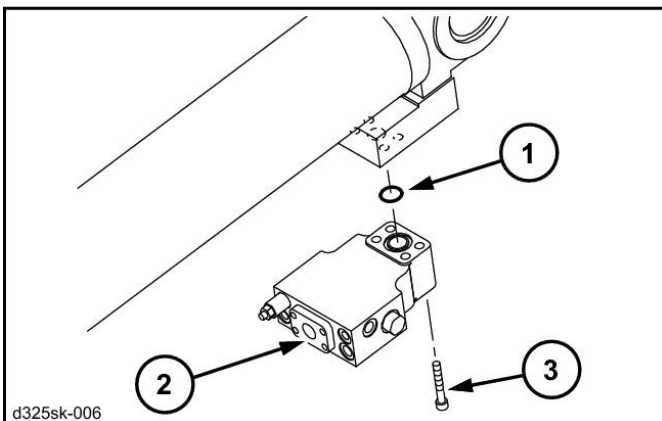

# Assembly and Disassembly of Swing Motor

## Causes of Trouble and Solutions

This list consists of actions to be taken when an abnormality is sensed or there are problems with functions during use of the hydraulic motor. Additionally, details concerning disassembly inspection and reassembly are listed after this, but sufficient caution should be exercised in handling during these actions so as to prevent scratching of sliding parts of the motor.

### 1. General cautions

This list consists of actions to be taken when an abnormality is sensed during use of the hydraulic motor. General cautions are listed below.

- 1) Think before attempting to fix a problem.  
Determine the nature of the abnormality before beginning work and think whether this same kind of problem has occurred before.  
Also, reconfirm whether the motor is the source of the problem.
- 2) Be careful about dust and dirt.  
The cause of wear is very often dust and dirt. So be careful that dust and dirt do not get into parts during disassembly.
- 3) Parts handling  
Parts are manufactured with a high degree of precision, so be careful not to scratch them during handling.
- 4) Do not damage O-rings or gasket surfaces while performing work. Also, it is recommended that O-rings are replaced for new ones during disassembly.

### 2. Investigating abnormalities in the motor main unit

It is very difficult to search for the source of troubles in the hydraulic circuits. Inspect the following items and thoroughly investigate whether the motor is the source of troubles.

- 1) Inspecting oil within the casing  
Remove the drain plug and inspect the hydraulic oil within the casing. If a large amount of metal particles come out at the same time as oil, it is very likely that there is damage with parts within the motor.
- 2) Existence of abnormal noise  
Check whether abnormal noise is coming from the motor main unit.
- 3) Measure pressure for each part.  
Do not perform disassembly inspection carelessly. Measure pressure for each part and look for abnormalities in each area.
- 4) Measure the amount of oil drained from the motor.
  - 1) Operation is normal if about 6 L/min or less of oil drains from the motor when pressure oil is applied after the swing is locked.
  - 2) 2 L/min or less of drained oil at constant swing is normal.

### 3. Trouble conditions and countermeasures

- 1) Hydraulic motor does not rotate.

Symptom	Cause	Solution
Pressure does not rise.	1) Incorrect setting of the circuit safety valve 2) Operation problems with relief valve 1) Plunger sticking 2) Clogged plunger orifice 3) Plunger seating problem	1) Reset safety valve correctly. 2) Disassemble and inspect. 1) Repair or replace sticking section. 2) Disassemble and clean. 3) Check seating sections and replace scratched part.
Pressure rises.	1) Overload 2) Seizing of driving part 3) No release pressure acting on the brake 4) Piston sticking to the brake 5) Spool for brake release sticking 6) Friction plate seizing	1) Eliminate load. 2) Inspect and repair piston/shoe, cylinder/valve plate, etc. 3) Inspect and repair circuit. 4) Disassemble and inspect. 5) Disassemble and inspect. 6) Disassemble and inspect. Replace seizing part.

# Explanation of Hydraulic Circuit and Operations (standard model)

## Travel Circuit

### Travel low-speed circuit

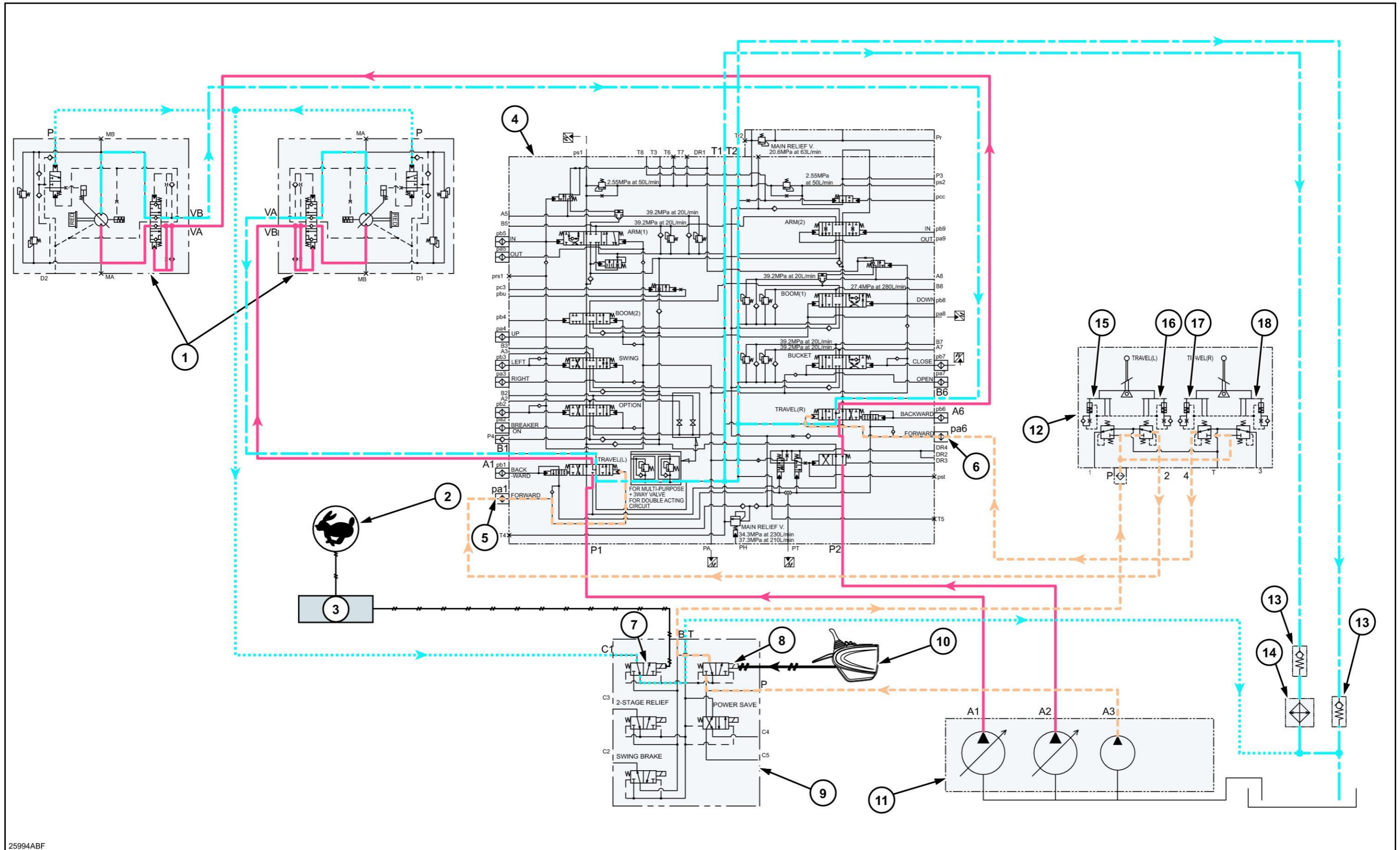

25994ABF

# Explanation of Hydraulic Circuit and Operations (standard model)

## Swing parking circuit (brake release)

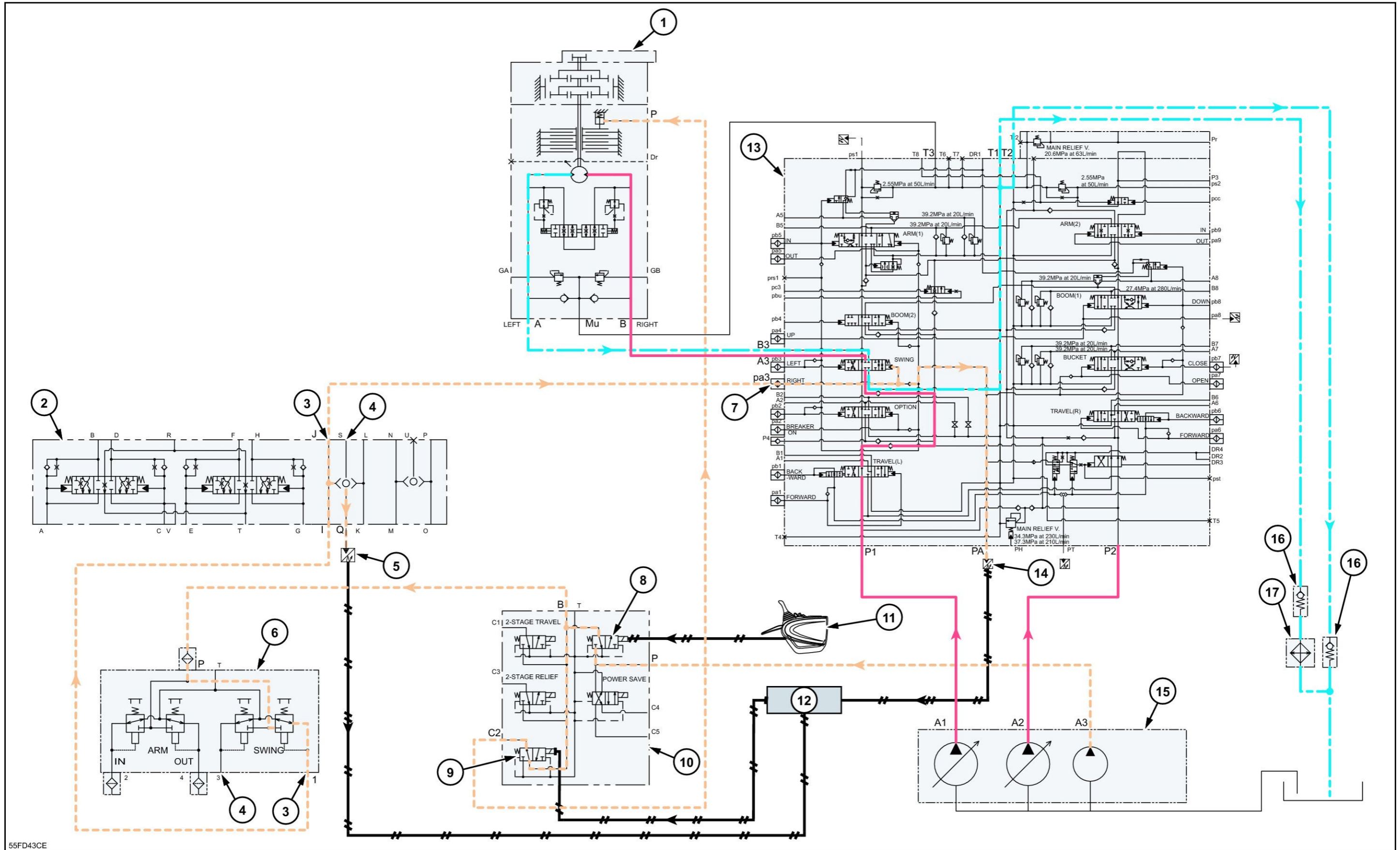

55FD43CE

# Explanation of Hydraulic Circuit and Operations (standard model)

## Boom-down load holding valve circuit

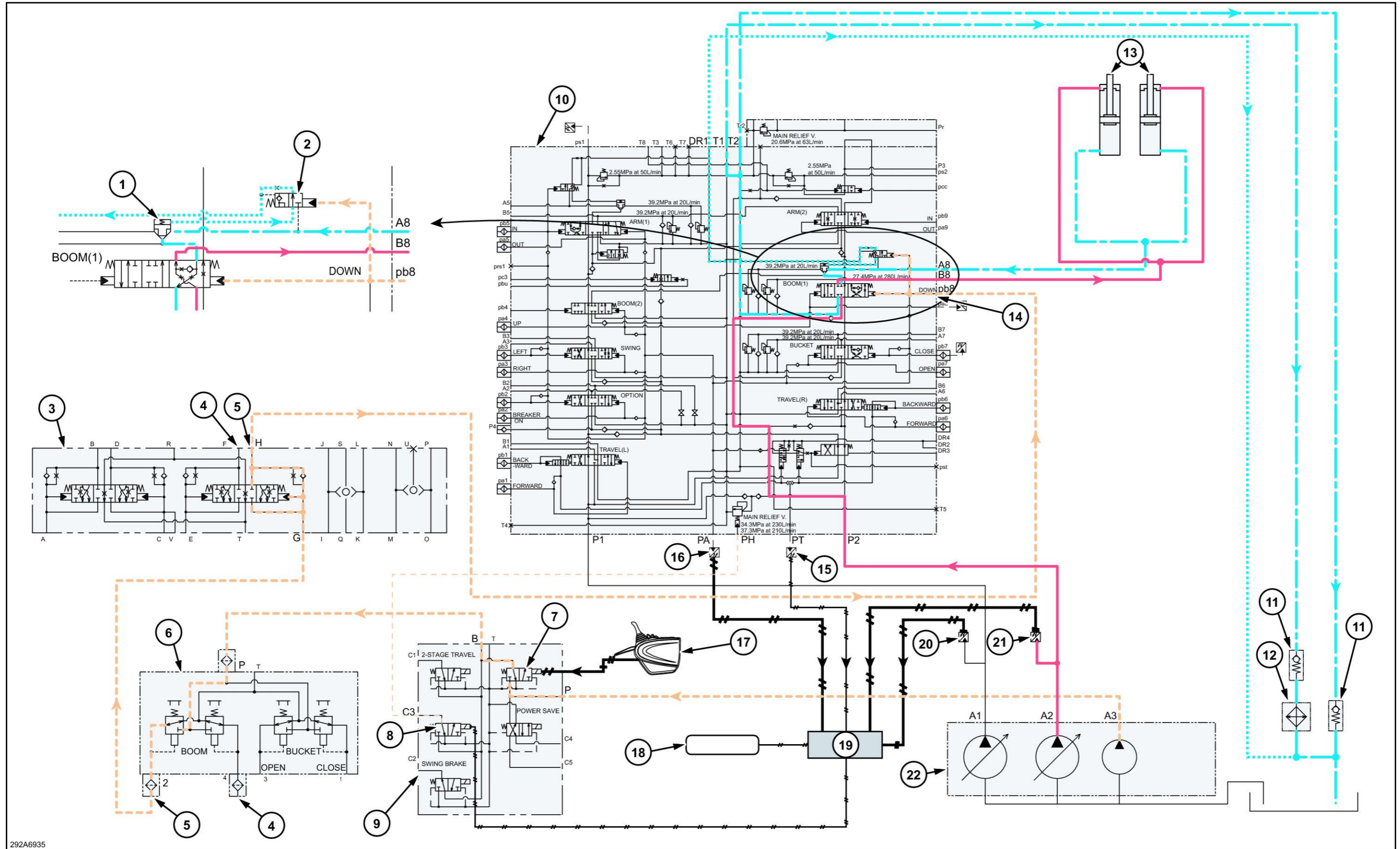

# Explanation of Hydraulic Circuit and Operations (standard model)

## Negative Control Circuit

Negative control circuit (power save solenoid OFF)

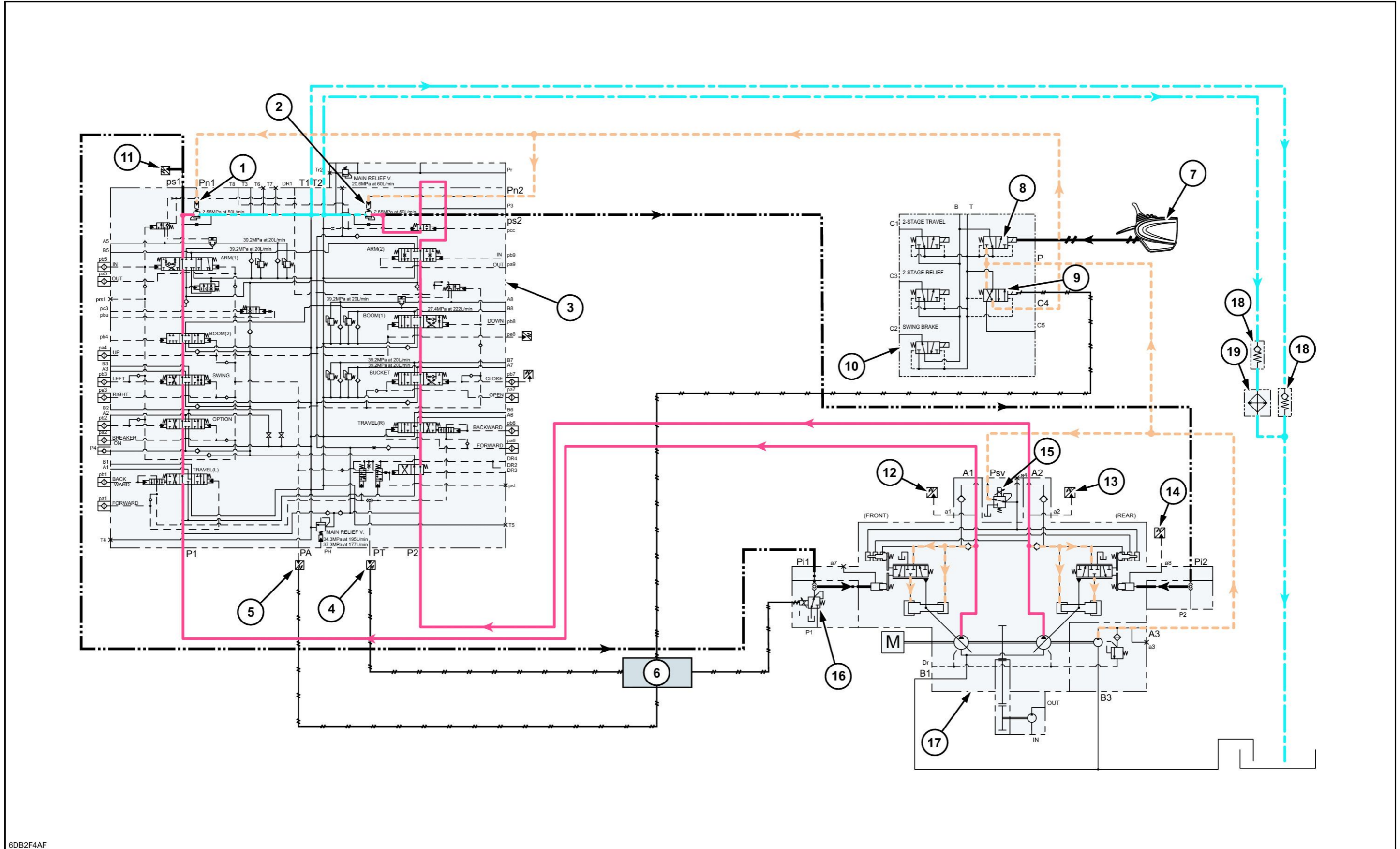

## Explanation of Hydraulic Circuit and Operations (standard model)

---

# Structure and Operation Explanation of Hydraulic Pump

## Hydraulic Pump Internal Structure Diagram

### Overall View

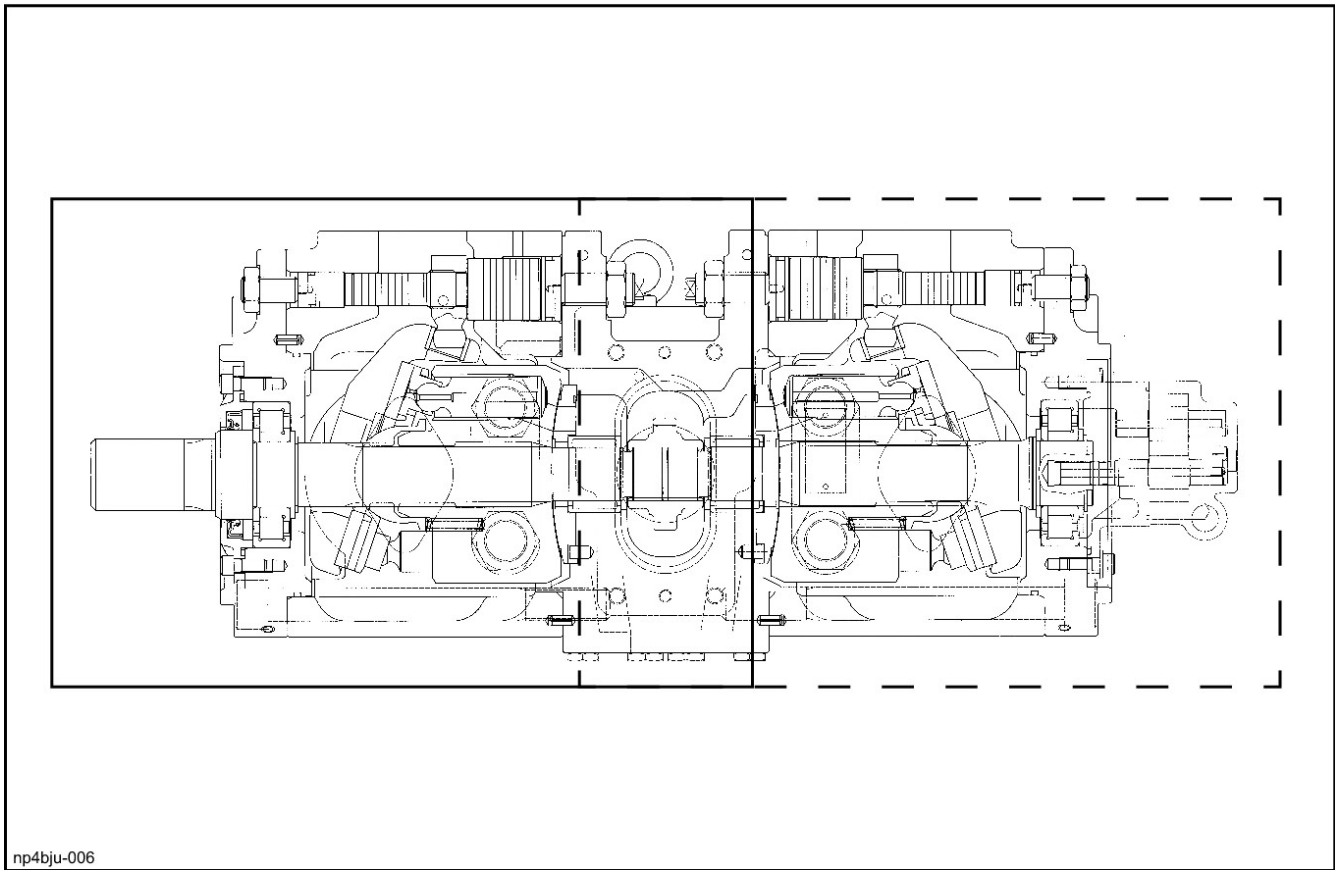

np4bjv-006

Drive shaft front side

Drive shaft rear side

# Structure and Operation Explanation of Travel Motor

Code	Part name	Code	Part name	Code	Part name
11	Pivot	32	Pin	53	Parallel pin
12	Shoe plate	33	Spring receiver	54	Valve plate
13	Cylinder block	34	Spring	55	Brake spring
14	Cylinder spring	35	Pilot valve plug	56	Hexagon socket head bolt
15	Spring receiver	36	O-ring	57	Overload valve
16	Spherical joint	37	Joint	58	Coupling
17	Shoe retainer	38	G1/4 plug	59	C-shaped retaining ring for hole
18	Piston assembly	39	O-ring 1B P11	60	G1/2 plug
19	Separator plate	40	Orifice (brake valve)	61	O-ring
20	Friction plate	41	Orifice spring (brake valve)		
21	Brake piston	42	G1/8 plug		

# Structure and Operation Explanation of Swing Motor

## Valve Casing Section

### 1. Anti-cavitation check section

Because the system using this type of motor does not have a valve with a counter-balance function, the motor sometimes rotates more than the quantity of oil fed.

In order to prevent cavitation due to insufficient oil, there is a check valve to take in the oil shortfall.

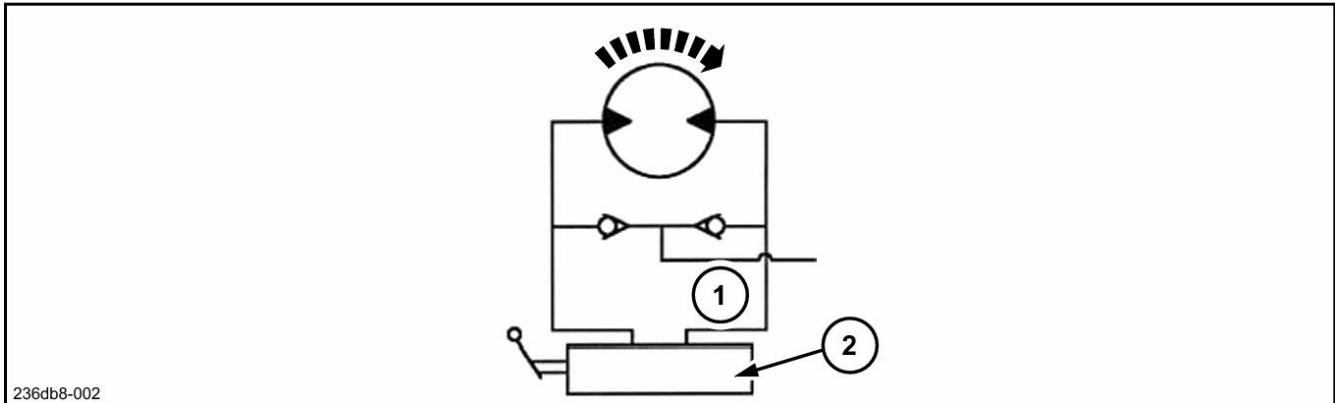

Diagram 2 Hydraulic circuit diagram

1	M port
2	Control valve

# Control Valve

---

- 2) Signal, straight travel signal control valve, plate assembly [Fig. 3]  
There are 2 signals, (a) and (b) below. The pilot signal for each spool for which a lever is operated is used to generate the pressure that is output.

The straight travel signal control valve integrates each signal pressure and controls straight travel spool switchover. Also, the plate assembly has a function for picking up the pilot pressures with the built-in shuttle.

- 1) Travel signal (PT)

The highest of the pilot pressures applied to the travel section 1 (pa1, pb1) and travel section 6 (pa6, pb6) is selected and output to the PT port.

Therefore, when the travel spool is in the neutral position (no-load pilot pressure), no pressure is generated at the PT port.

- 2) Front signal (PA)

The highest of the pilot pressures (pa2 - 9 and pb2 - 9) applied to sections 2 - 9 that use the pressurized oil from the P1 and P2 pumps, except for the travel sections, is selected and output to the PA port. (Note 1)

Therefore, when all the spools are in the neutral position (no-load pilot pressure), no pressure is generated at the PA port.

<Note 1>

When an add-on (main pump add-on) is used through the feed from P2, the branches for the add-on pilot signals par1 and pbr1 are connected to the respective main unit valves, prs1 and prs2 ports, and thus incorporated in the front signal PA selection area.

Be careful. If the above line connection is not done, the PA pressure will not rise through add-on selection. Also, when using 2 main pump add-ons, set the circuit so that the maximum of the add-on pilot pressures (par1 and 2, pbr1 and 2) can be taken out as desired and connect to either prs1 or prs2.

# Control Valve

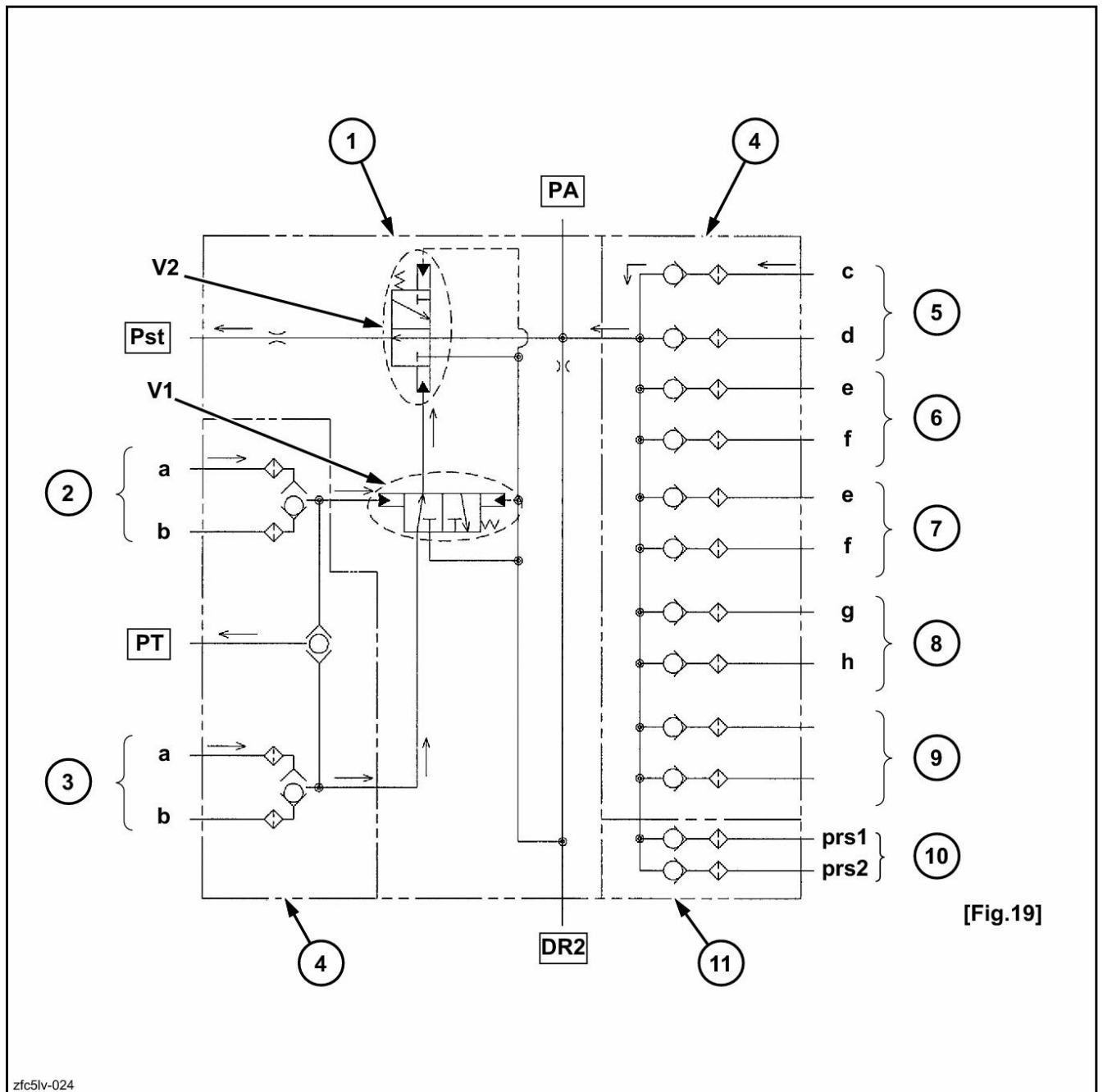

[Fig.19]

zfc5lv-024

1	Straight travel signal control valve	5	Boom	9	Option
2	Travel 1	6	Arm	10	Add-on (main pump)
3	Travel 2	7	Bucket	11	Main unit housing section (option)
4	Plate assembly	8	Swing		

a	Advance	d	Down	g	Right
b	Reverse	e	Close	h	Left
c	Up	f	Open		

# 5 Stack Solenoid Valve Operation Explanation

## Operation Explanation

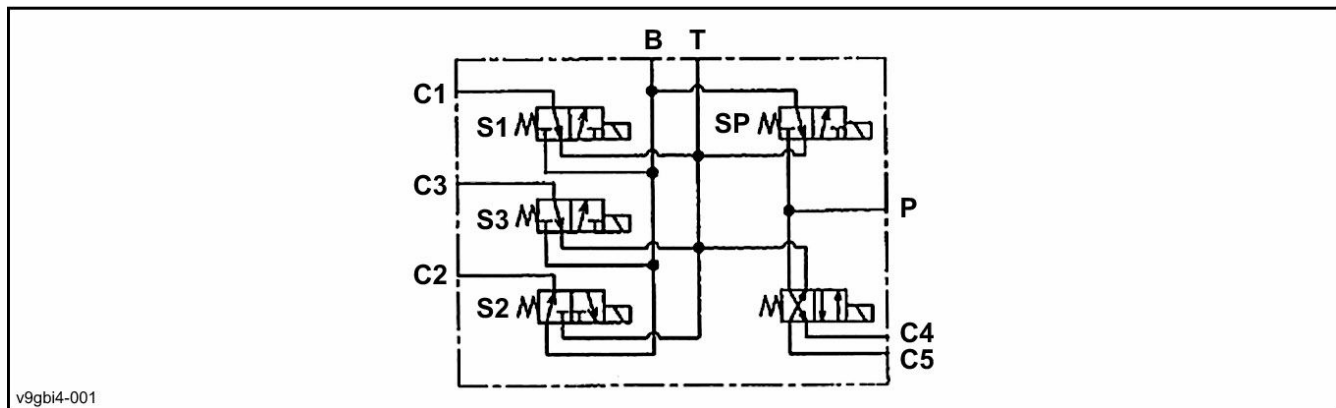

Hydraulic circuit diagram

The pressure oil fed from the P port feeds pressure oil to the C1 - C5 ports according to the excitation or non-excitation of electromagnetic switchover valves S1 - S4 resulting from exciting electromagnetic switchover valve SP.

- Electromagnetic switchover valves S1, S3 → Oil passing through when valve excited
- Electromagnetic switchover valve S2 → Oil passing through when valve not excited
- Electromagnetic switchover valve S4 → Oil passing to C5 when valve excited Oil passing to C4 when valve not excited

# Structure and Operation Explanation of Travel Pilot Valve (remote control valve)

## 2. Lever stroke state and operation when lever is moved back

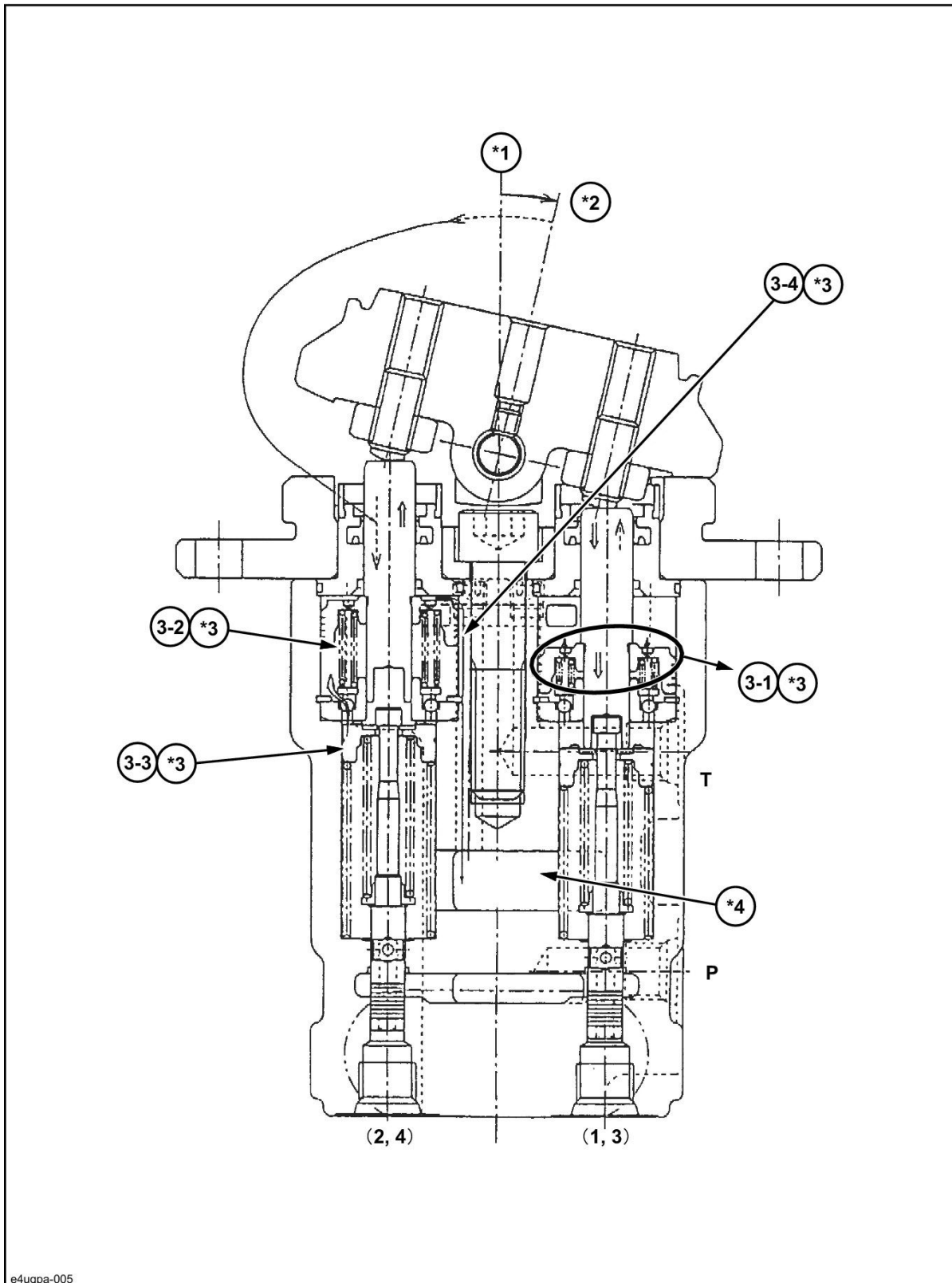

e4uqpa-005

*1	Neutral	*3	(⇒ during operation)
*2	Full stroke 12.5°	*4	Oil drains to T.



# Section

# 9003A

## Removal and Installation of Bucket



# Section

# 9003D

## Removal and Installation of Boom

# CONTENTS

---

Removal of Cab Assembly .....	3
Installation of Cab Assembly .....	8



# Section

# 9005D

## Removal and Installation of Wiper Motor

# CONTENTS

---

Window Lock (front side) .....	3
Window Lock (rear side) .....	4

# Air Conditioner Overall Diagram

## Equipment Layout Diagram

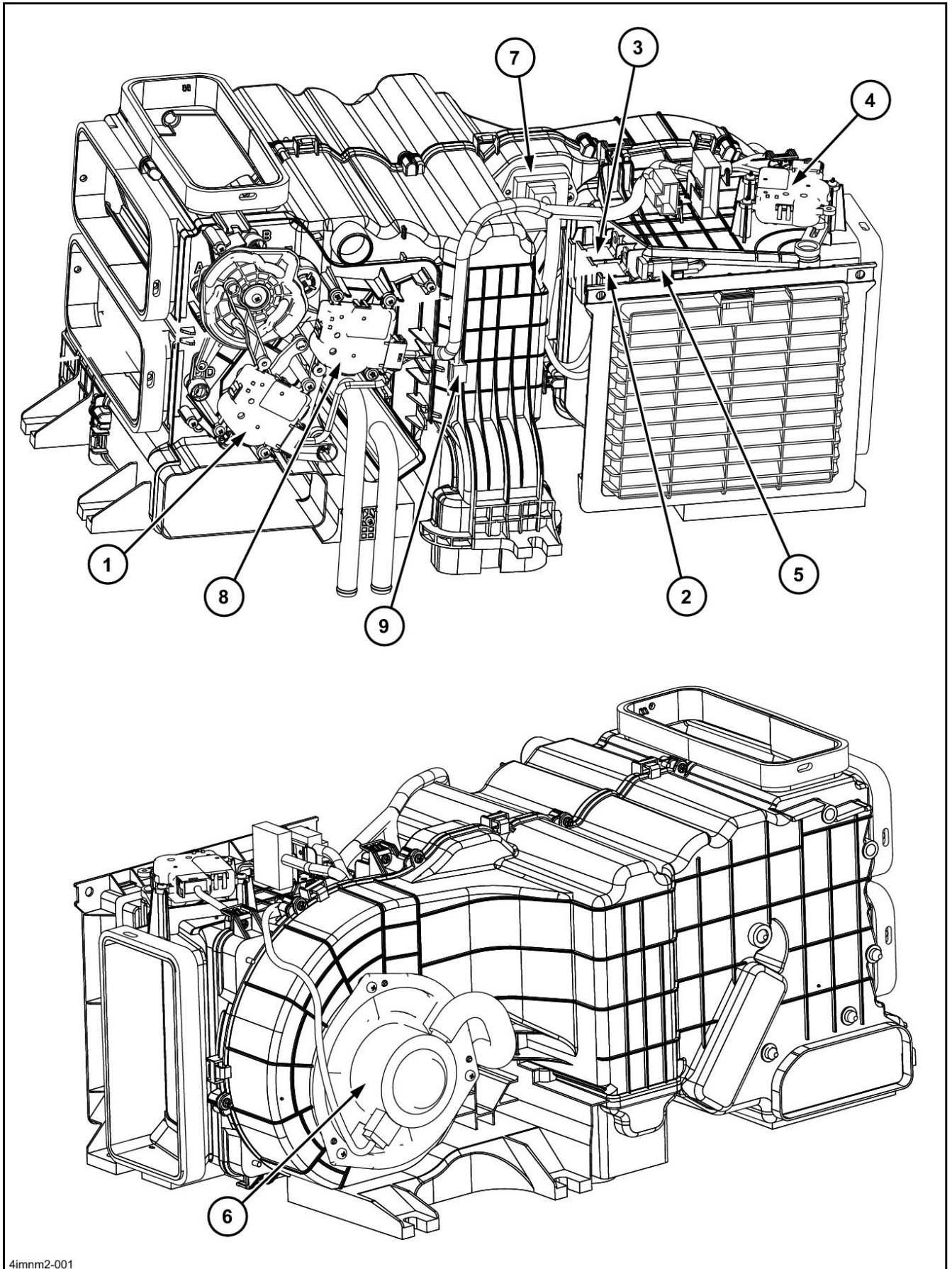

4imnm2-001

CLICK HERE TO **DOWNLOAD** THE COMPLETE MANUAL

- Thank you very much for reading the preview of the manual.
- You can download the complete manual from: [www.heydownloads.com](http://www.heydownloads.com) by clicking the link below



- Please note: If there is no response to CLICKING the link, please download this PDF first and then click on it.

CLICK HERE TO **DOWNLOAD** THE COMPLETE MANUAL