

CX250D
CX250D Long Reach
LC Version
Tier 4B (final)
Crawler Excavator

SERVICE MANUAL

Part number 47843012

1st edition English
February 2015



CLICK HERE TO **DOWNLOAD** THE COMPLETE MANUAL

- Thank you very much for reading the preview of the manual.
- You can download the complete manual from: www.heydownloads.com by clicking the link below



- Please note: If there is no response to CLICKING the link, please download this PDF first and then click on it.

CLICK HERE TO **DOWNLOAD** THE COMPLETE MANUAL

Engine-related**Engine**

Engine model name	Isuzu 4HK1X diesel engine
Engine type	4-cycle, water-cooled, overhead camshaft, vertical in-line, direct injection type (electronics control type)
Number of cylinders - diameter - stroke	4- ϕ 115 mm (4.53 in) - 125 mm (4.92 in)
Total displacement	5.193 L (1.372 US gal)
Compression ratio	16.5
Rated output	132.1 kW (179.61 Hp) / 2000 RPM
Maximum torque	621 N·m (458.03 lb ft) / 1800 RPM
Engine dry weight	About 520 kg (1146.404 lb)
Cooling fan	650 mm (25.591 in) - suction type - 7 blades resin
	With bell mouth-type fan guide
Pulley ratio	0.85 (reduction)
Charging generator	24 V 50 A AC type
Starter motor	24 V 5 kW (6.8 Hp) reduction type
Coolant capacity	14.5 l (3.830 US gal)
Oil pan capacity	Max: 20 L (5.283 US gal) Min: 13 L (3.434 US gal)
Direction of rotation	Right (viewed from fan side)

Air cleaner (double element)

Manufacturer	Nippon Donaldson, Ltd.	
Element (outer)	Filtering area size	5.23 m ² (56.30 ft ²)
Element (inner)	Filtering area size	0.11 m ² (1.18 ft ²)
Weight	7.5 kg (16.535 lb)	

Radiator

Manufacturer	T.Rad. Co.,Ltd.	
Oil cooler	Weight	32.3 kg (71.209 lb)
	Oil volume	13.6 L (3.593 US gal)
Radiator	Weight	17.0 kg (37.479 lb)
	Coolant capacity	10.0 L (2.642 US gal)
Air cooler	Weight	7.3 kg (16.094 lb)
	Capacity	-
Fuel cooler	Weight	1.1 kg (2.425 lb) x 2
	Capacity	0.44 L (0.1162 US gal) x 2
Total weight	115 kg (253.532 lb)	

SCR

Manufacturer	Tokyo Radiator MFG. Co.,Ltd.	
Urea capacity	138.1 L (36.482 US gal)	
Weight	13.6 kg (29.98 lb)	

Product identification

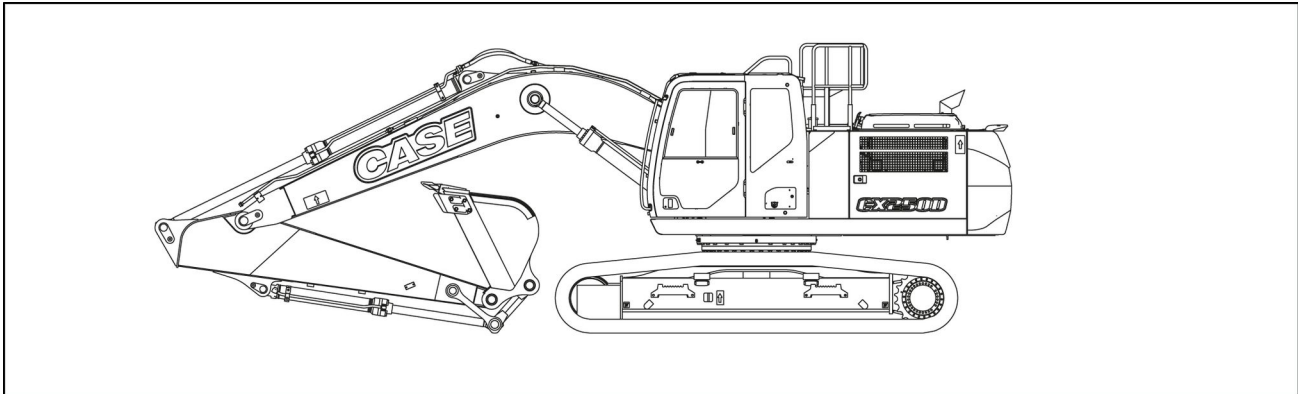

SMIL14CEX1601EA 1

Standard version

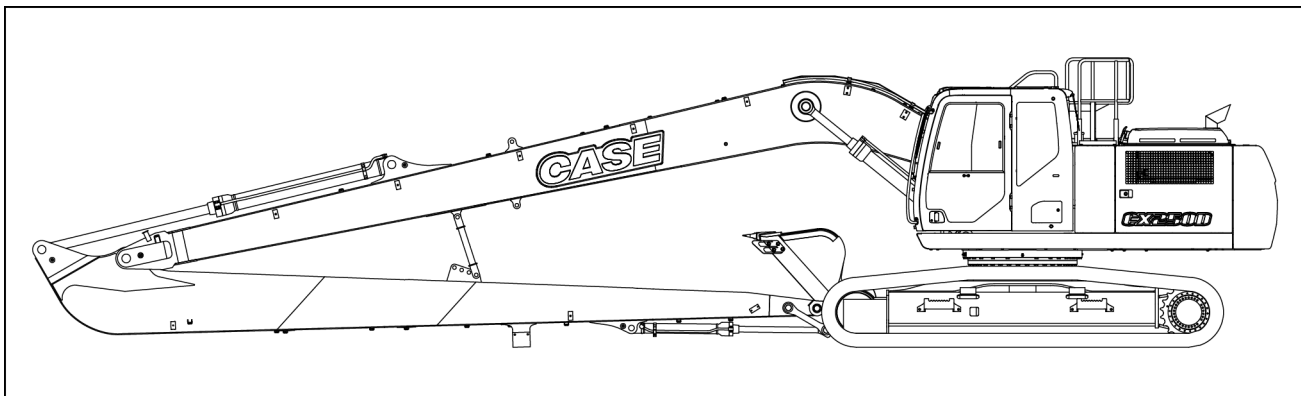

D13C0D38 2

Long Reach version

When ordering parts, obtaining information or assistance, always supply your CASE CONSTRUCTION Dealer with the type and serial number of your machine or accessories. Write the following in the spaces below: the type, serial number and year of manufacture of your machine, accessories and the serial numbers of the various hydraulic and mechanical components.

Machine

(1) Designation / Model:
Hydraulic Excavator CX250D

(2) Product identification number (PIN):



SMIL14CEX1603AB 3

EGR gas temperature sensor 1 removal

1. Disconnect the harness connector from the EGR gas temperature sensor 1 (1).
2. Remove the EGR gas temperature sensor 1 (1) from EGR pipe A.

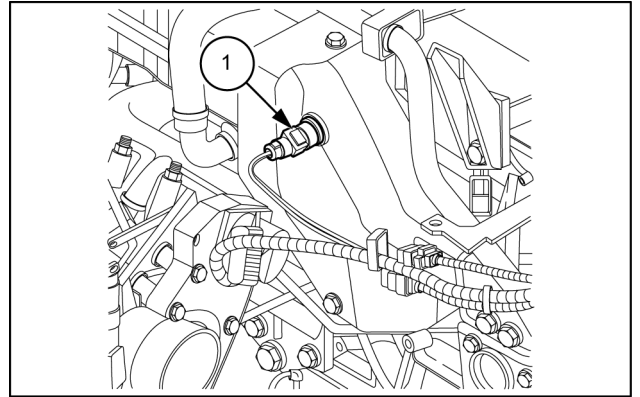

SMIL14CEX5662AB 14

EGR gas temperature sensor 2 removal

1. Disconnect the harness connector from the EGR gas temperature sensor 2 (1).
2. Remove EGR gas temperature sensor 2 (1) from the EGR pipe C.
3. Remove the harness bracket from the EGR pipe C.

NOTE: Remove together with the clip.

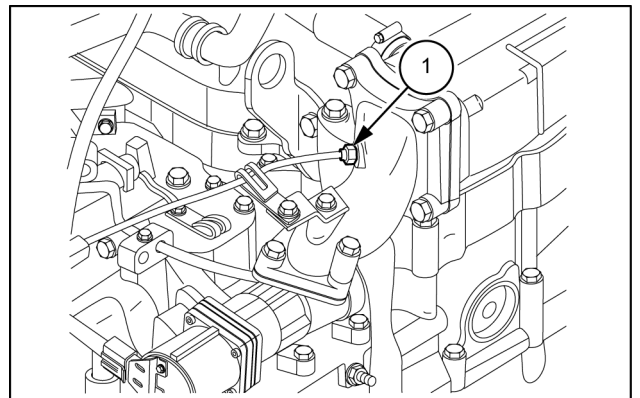

SMIL14CEX5663AB 15

EGR cooler assembly removal

1. Disconnect the water rubber hose (1) from the EGR cooler assembly.

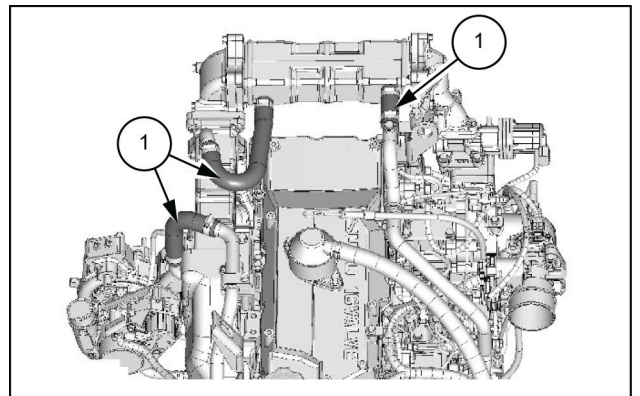

SMIL13CEX1476AB 16

7. Install the center bolt to the sleeve.
8. Tighten the center bolt using the wrench.

NOTE: Tighten the center bolt until the sleeve touches the adapter.

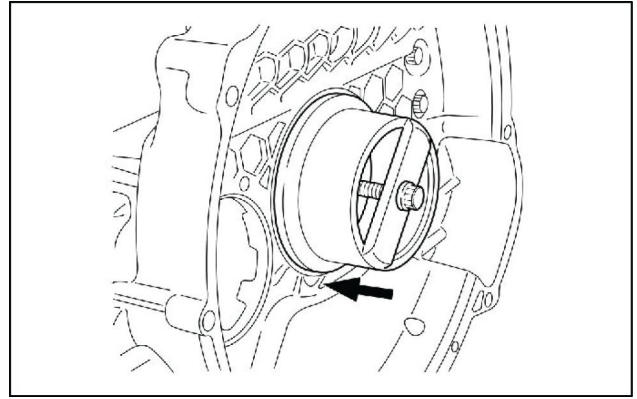

SMIL13CEX1659AA 35

9. Inspect the crankshaft rear oil seal.

NOTE: Measure the distance between the crankshaft head and the crankshaft rear oil seal.

Specified value: **7.2 - 7.8 mm (0.2835 - 0.3071 in)**

1. Crankshaft
2. Crankshaft rear oil seal
3. Measurement location
4. Collar
5. Adapter ring
6. Sleeve
7. Adapter

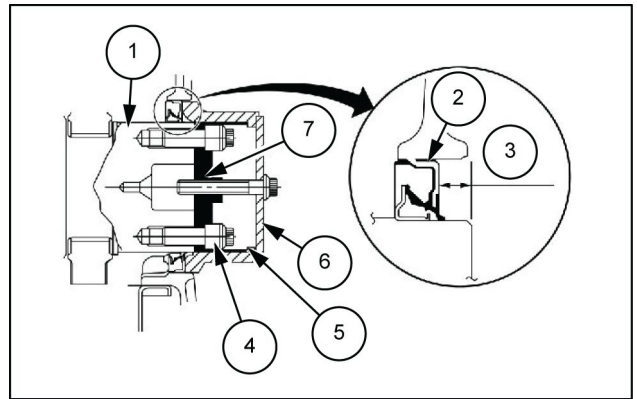

SMIL13CEX1660AB 36

Flywheel installation

1. Apply the disulfide molybdenum grease to the bolt.

NOTE: Apply to the seat surface and threaded portion on the flywheel installation bolts.

2. Install the flywheel to the crankshaft.

NOTE: Tightening order.

CAUTION: Pay attention to the knock pin position of the crankshaft.

3. Tighten the bolt using the torque wrench.

Tightening torque: **78 N·m (58 lb ft)**

4. Tighten the bolt using the special tool.
Special tool: Angle gauge (Refer to **Cylinder heads - Special tools (10.101)**)

Tightening angle: **120 °**

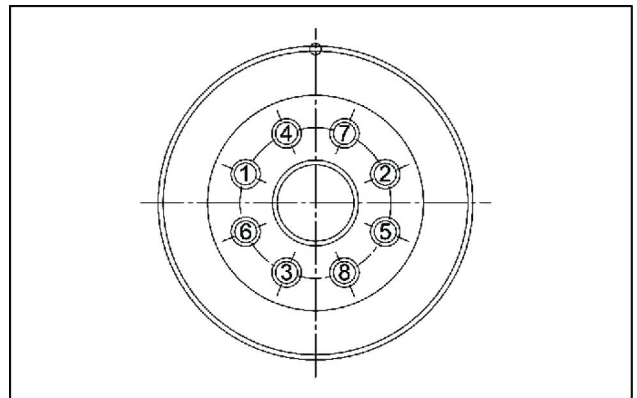

SMIL13CEX1661AA 37

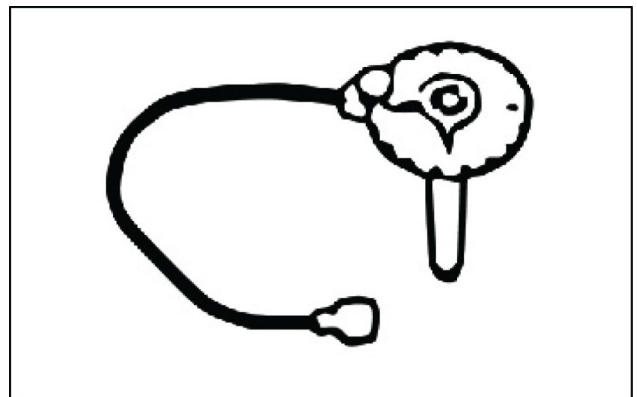

SMIL13CEX1662AA 38

Pan and covers - Remove

Oil pressure sensor

1. Disconnect the harness connector from the oil pressure sensor **(1)**.
2. Remove the oil pressure sensor from the oil port cover **(2)**.
3. Starter assembly.

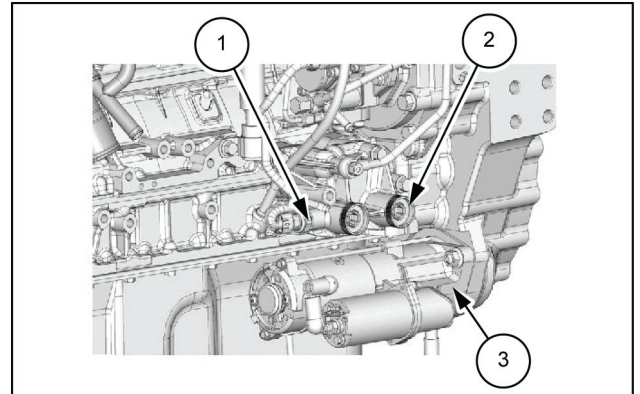

SMIL13CEX1867AB 1

Oil port cover

1. Disconnect the oil feed pipe from the oil port cover.
2. Remove the oil port cover from the cylinder block.
3. Remove the O-ring **(1)** and the O-ring **(2)** from the oil port cover.

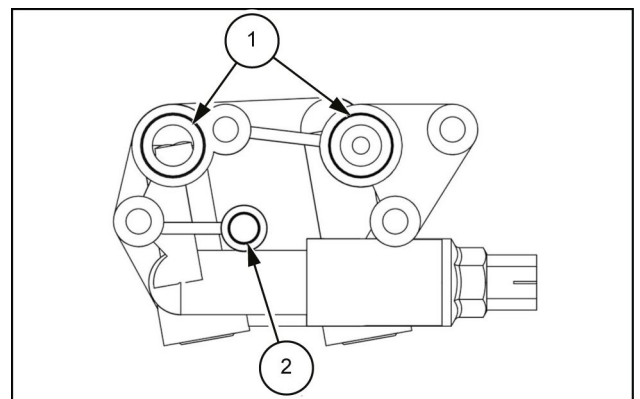

SMIL14CEX3223AB 2

8. Disconnect the water return pipe (1) from the turbocharger assembly.
9. Remove the water return pipe (1) from the water pump assembly.
10. Disconnect the water feed pipe (2) from the turbocharger assembly.

NOTE: Remove the clip.

11. Remove the water feed pipe (2) from the cylinder block.

NOTE: Remove the clip.

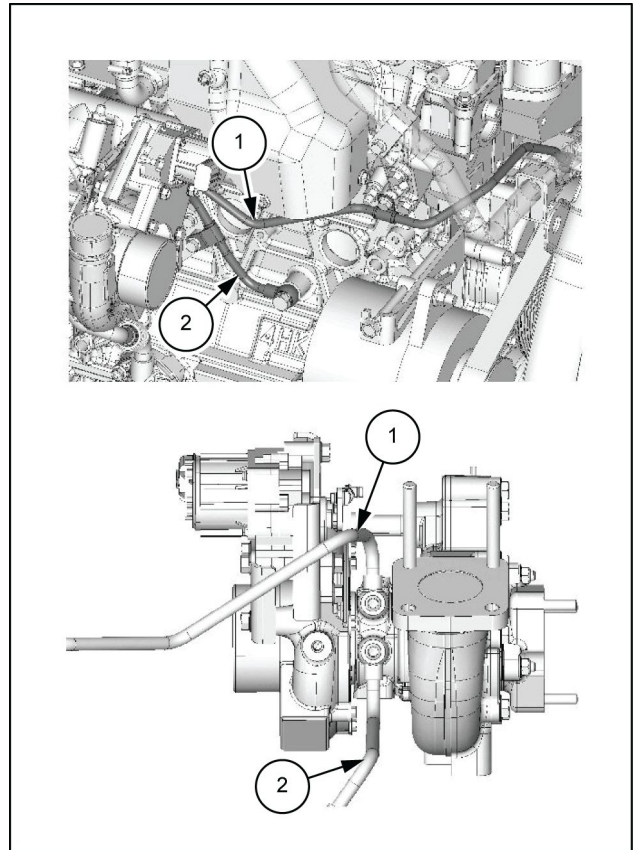

SMIL13CEX1128BB 4

12. Remove the exhaust manifold stay (3) from the cylinder block and the turbocharger assembly (1).
2. Exhaust manifold

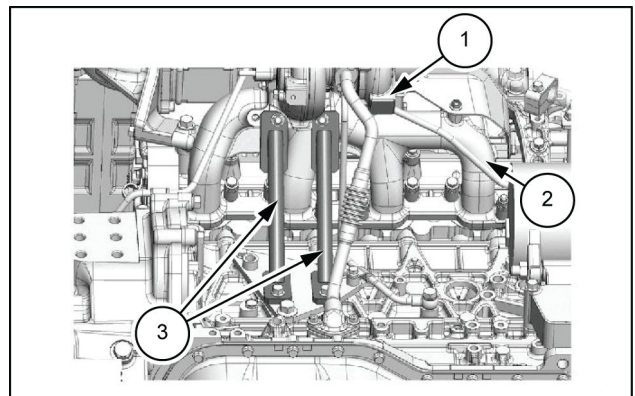

SMIL13CEX1129AB 5

13. Disconnect the harness connector from the turbocharger assembly (2).
14. Remove the turbocharger assembly (2) from the exhaust manifold (1).

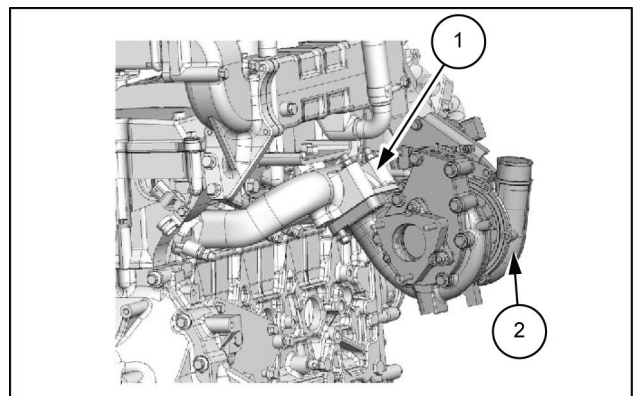

SMIL13CEX1130AB 6

Oil level gauge guide tube installation

1. Install the oil level gauge guide tube to the cylinder block (4).
2. Connect the oil level gauge guide tube to the case (3).
Tightening torque: **19 N·m (14 lb ft)**
3. Connect the oil level gauge guide tube to the cylinder head cover (1).
Tightening torque: **19 N·m (14 lb ft)**
4. Install the oil level gauge to the oil level gauge guide tube (2).

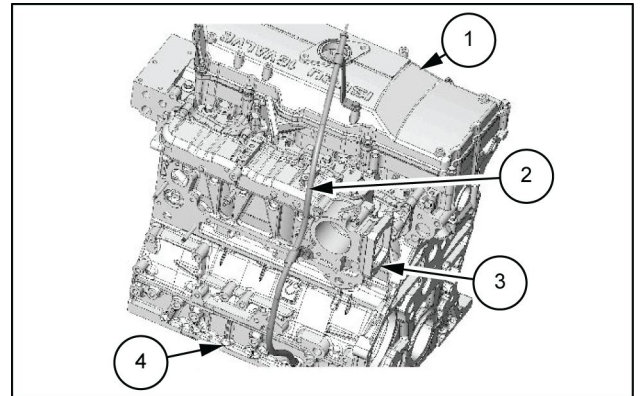

SMIL13CEX1804AB 47

Inlet pipe installation

1. Install the gasket (2) and the inlet pipe (3) to the case (1).

Tightening torque: **24 N·m (18 lb ft)**

⚠ CAUTION: Use new gaskets.

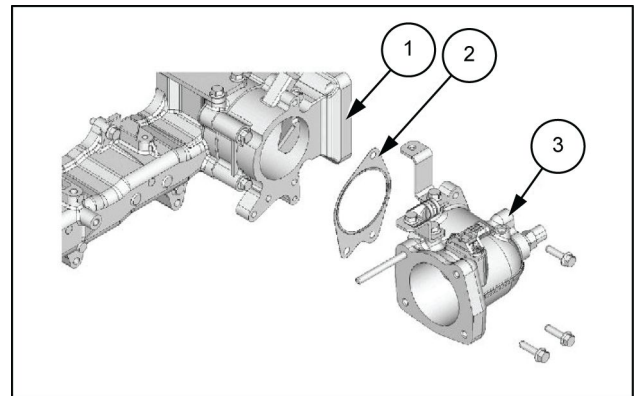

SMIL13CEX1805AB 48

2. Connect the harness connector to the IMT sensor (1).
 3. Connect the harness connector to the EGR valve (3).
 4. Connect the harness connector to the boost pressure sensor/boost temperature sensor (5).
 5. Install the harness clip (4) to the inlet pipe.
2. EGR gas temperature sensor 2

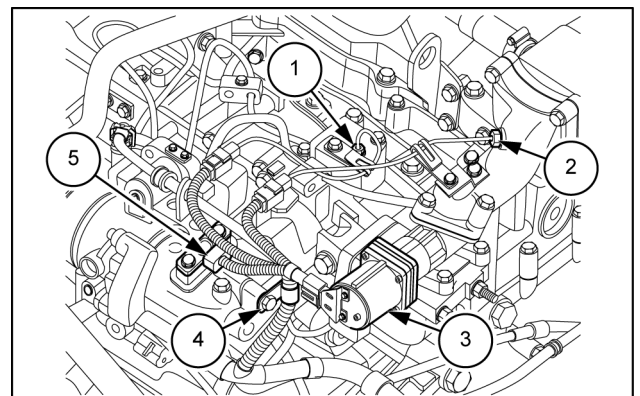

SMIL14CEX5654AB 49

Valve cover - Remove

Cylinder head cover removal

1. Disconnect the oil level gauge guide tube **(2)** from the cylinder head cover.
2. Disconnect the ventilation hose **(1)** from the air breather.

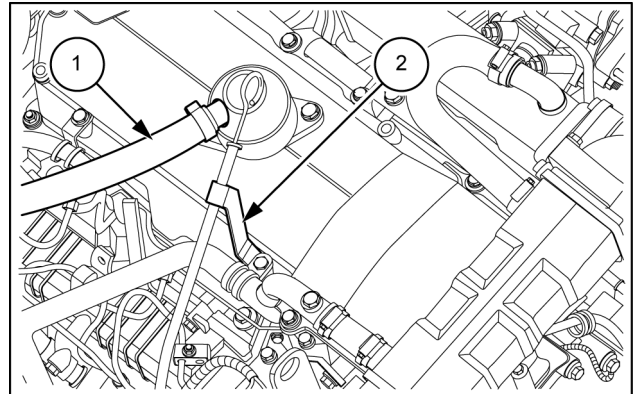

SMIL14CEX5660AB 1

3. Remove the cylinder head cover **(1)** from the lower cover **(3)**.
4. Remove the head cover gasket **(2)** from the cylinder head cover **(1)**.

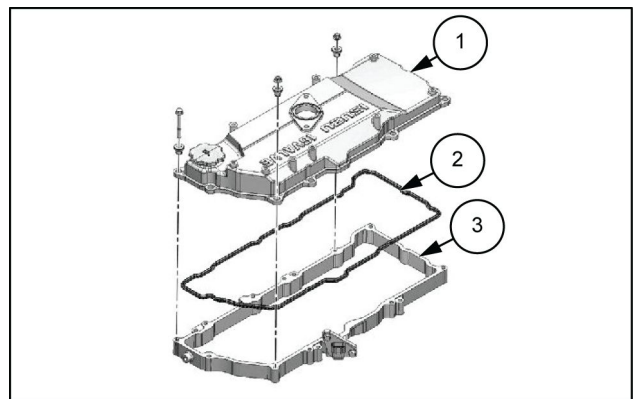

SMIL13CEX1803AB 2

Rocker arm shaft installation

1. Apply the engine oil to the bracket.

NOTE: Apply to each sliding surface.

2. Apply the engine oil to the rocker arm.

NOTE: Confirm that the adjust screw is fully loosened.

1. Nut
2. Bolt
3. Bolt
4. Bolt

3. Temporarily tighten the bolts (2), (3), and (4) to the cylinder head assembly.

NOTE: Apply engine oil to the threaded portion of the bolts.

4. Temporarily tighten the nut (1) to the cylinder head assembly.

NOTE: Apply engine oil to the threaded portion of the nuts.

5. Securely tighten the rocker arm shaft to the cylinder head assembly.

NOTE: Hold the entire rocker arm shaft horizontally and gradually tighten it.

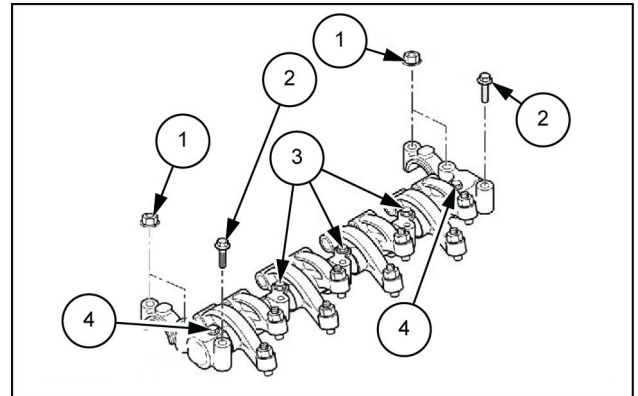

SMIL13CEX1688AB 8

Rocker arm shaft tightening torque

Parts	Description	Tightening torque
No.1	Nut	21 N·m (15 lb ft)
No.2	Bolt	27 N·m (20 lb ft)
No.3	Bolt	56 N·m (41 lb ft)
No.4	Bolt	27 N·m (20 lb ft)

Rocker arm shaft adjustment

NOTE: Valve clearance adjustment

⚠ CAUTION:

- Adjust the valve clearance while cool.
- Loosen all adjust screws before adjustment.

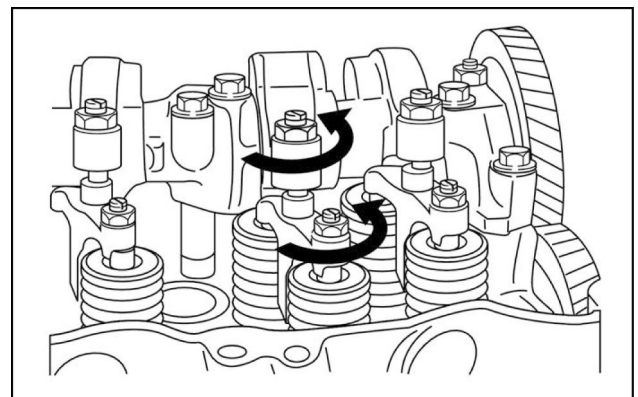

SMIL14CEX3082AA 9

Rocker arm shaft adjustment

NOTE: Valve clearance adjustment

CAUTION:

- Adjust the valve clearance while cool.
- Loosen all adjust screws before adjustment.

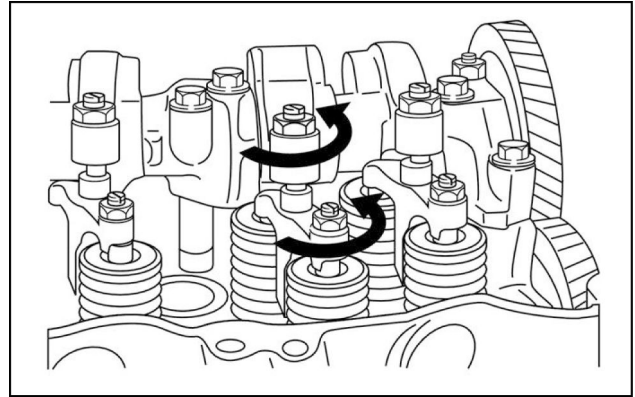

SMIL14CEX3082AA 12

1. Align No.1 cylinder to the compression top dead center.

1. Front cover marking
2. 0° marking on the crankshaft damper

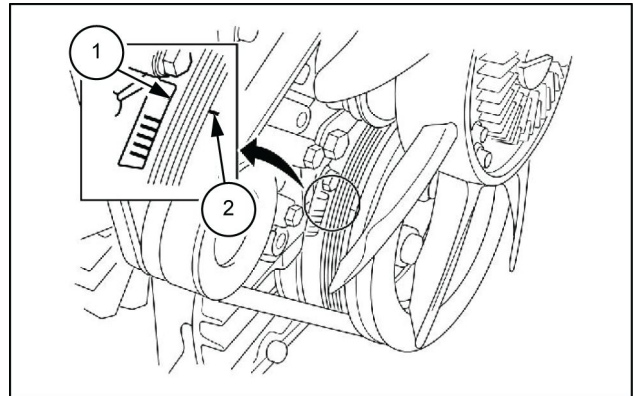

SMIL13CEX1690AB 13

2. Prepare the feeler gauge.

Thickness : **0.4 mm (0.0157 in)**

NOTE: Insert the thickness gauge between the rocker arm and bridge cap.

3. Turn the adjust screw.

NOTE: When the movement of the thickness gauge becomes stiff, secure the adjust screw nut of the rocker arm.

Tightening torque: **22 N·m (16 lb ft)**

4. Turn the adjust screw.
5. With the thickness gauge inserted, lightly tighten the adjust screw of the bridge.
6. Confirm that the leading end of the adjust screw and valve shaft end have made contact and the movement of the thickness gauge has become stiff.
7. Check if the valve shaft end on the opposite side is floating or touching at an angle.
8. If it is floating or touching at an angle, slightly loosen the bridge adjust screw and adjust the valve shaft ends on both sides to touch properly.

Clearance : Less than **0.1 mm (0.0039 in)** between valve and bridge

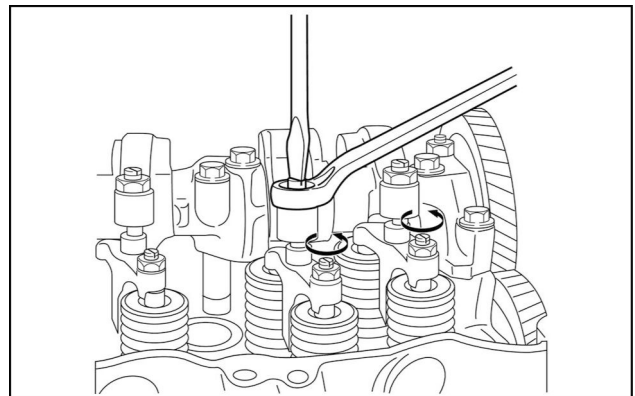

SMIL14CEX3083AA 14

4. Remove the piston from the cylinder block.

NOTE: *Pull out the piston and connecting rod together to the cylinder head side.*



CAUTION: Be careful not to damage the oil jet.

5. Remove the connecting rod bearing from the connecting rod.

NOTE: *Organize the removed bearings by the cylinders using tags, etc.*

9. Install the oil return pipe (3) to the cylinder block.

CAUTION: Use new gaskets.

Tightening torque: **22 N·m (16 lb ft)**

10. Connect the oil return pipe (3) to the turbocharger assembly (1).

CAUTION: Use new gaskets.

Tightening torque: **9 N·m (6.64 lb ft)**

11. Replenish the turbocharger assembly with the engine oil.

12. Install the oil feed pipe (2) to the oil port cover.

CAUTION: Use new gaskets.

Tightening torque: **17 N·m (13 lb ft)** eyebolt

Tightening torque: **24 N·m (18 lb ft)** clip

13. Connect the oil feed pipe (2) to the turbocharger assembly (1).

CAUTION: Use new gaskets.

Tightening torque: **29 N·m (21 lb ft)** eyebolt

Tightening torque: **24 N·m (18 lb ft)** clip

14. Install the exhaust pipe to the turbocharger assembly (1).

15. Install the air intake hose to the turbocharger assembly (1) and the intercooler.

16. Install the air cleaner duct to the air cleaner assembly and the turbocharger assembly (1).

17. Connect the harness connector to the turbocharger assembly (1).

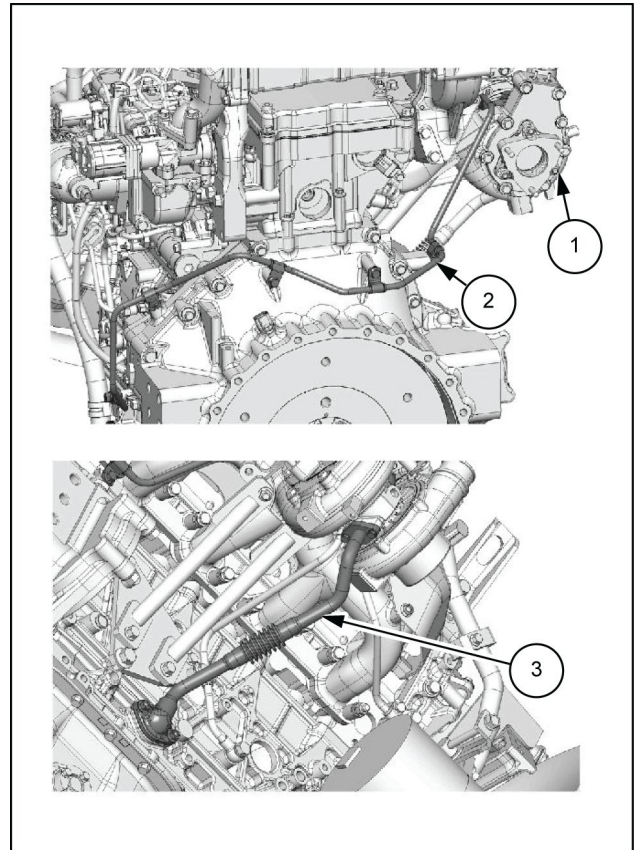

SMIL13CEX1821BB 48

Engine harness connect

1. Connect the engine harness to the engine assembly.

NOTE: Connect each connector.

Engine oil filling

1. Replenish the engine assembly with the engine oil.

NOTE: Add engine oil up to the MAX position of the oil level gauge.

CAUTION: Check the tightening of the drain plug before adding engine oil.

Fuel pipe removal

1. Remove the fuel pipe from the fuel supply pump and the common rail assembly.

NOTE: Remove the clip.

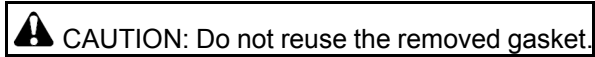

Fuel leak off pipe assembly removal

1. Disconnect the fuel leak-off pipe (3) from the cylinder head (2).
2. Remove the fuel leak-off pipe (3) from the fuel supply pump (4).

NOTE: Remove the eyebolt tightened together with the fuel feed pipe.

3. Disconnect the fuel leak-off pipe (3) from the common rail assembly (1).
4. Remove the fuel leak-off pipe (3) from the inlet pipe.

NOTE: Remove the clip.

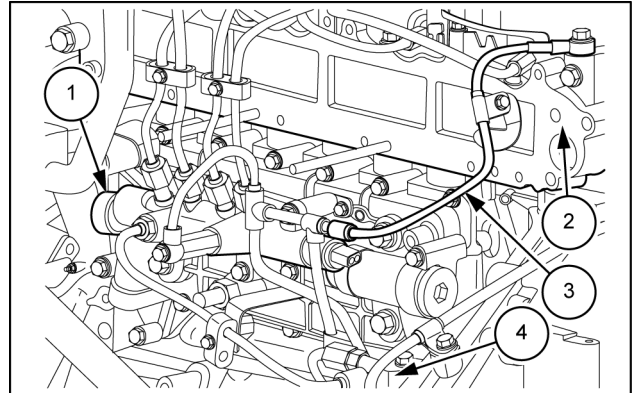

SMIL14CEX5652AB 30

Common rail assembly removal

1. Disconnect the harness connector from the fuel pressure sensor (2).
2. Remove the common rail assembly (1) from the inlet cover, and the common rail bracket (3).
3. Remove the common rail bracket (3) from the oil cooler assembly.

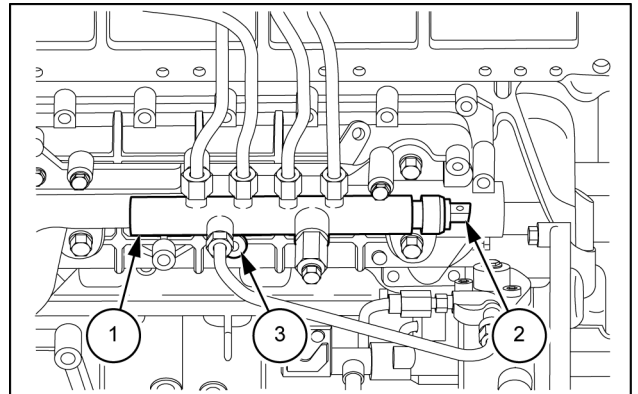

SMIL14CEX5651AB 31

Cylinder head cover removal

1. Disconnect the ventilation hose from the air breather.
2. Remove the cylinder head cover (1) from the lower cover (3).
3. Remove the head cover gasket (2) from the cylinder head cover (1).

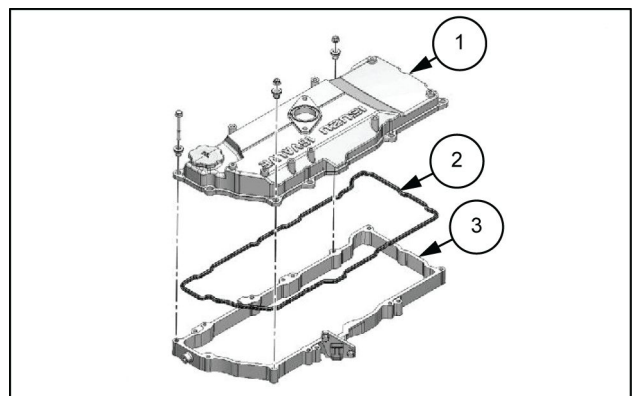

SMIL13CEX1147AB 32

Adjustment table

Cylinder No.	1		2		3		4	
	IN	EX	IN	EX	IN	EX	IN	EX
No. 1 cylinder compression top dead center	o	o	o			o		
No. 4 cylinder compression top dead center				o	o		o	o

Common rail assembly installation

1. Temporarily tighten the common rail bracket to the oil cooler assembly.

NOTE: The installation bolt and common rail assembly are tightened together.

2. Align the common rail assembly to the inlet cover.
3. Align the common rail assembly to the common rail bracket.
4. Temporarily tighten the nut to the common rail assembly.

NOTE: The stud bolts of the inlet cover are tightened together.

5. Temporarily tighten the bolt to the common rail assembly.
6. Securely tighten the nut to the common rail assembly.

Tightening torque: **22 N·m (16 lb ft)**

NOTE: Refer to the tightening order in the diagram if the inlet cover is removed.

7. Securely tighten the bolt to the common rail assembly **(1)**.

Tightening torque: **19 N·m (14 lb ft)**

8. Connect the harness connector to the fuel pressure sensor **(2)**.

1. Common rail assembly
2. Fuel pressure sensor
3. Common rail bracket

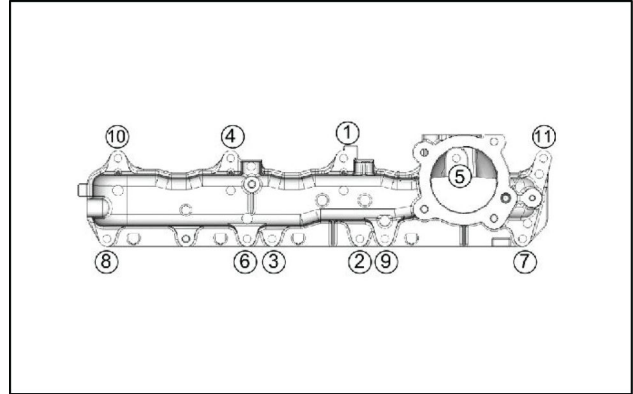

SMIL13CEX1693AA 63

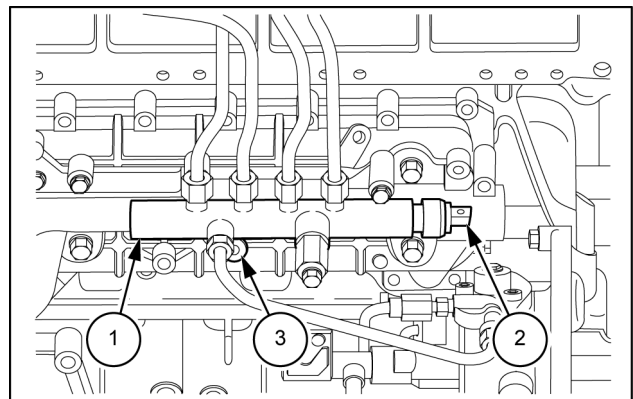

SMIL14CEX5651AB 64

Fuel tank - Install

To install, perform the reverse of the removal procedure.

When installing the bolts, tighten them to the specified torque.

If the torque is not specified, see the **Torque – Bolt and nut ()**.

Finally, carefully check for any fuel leaks.

Fuel leak off pipe assembly Installation

1. Temporarily tighten the fuel leak-off pipe (3) to the cylinder head assembly (2).

 CAUTION: Use new gaskets.

2. Temporarily tighten the fuel leak-off pipe (3) to the common rail assembly (1).

 CAUTION: Use new gaskets.

3. Temporarily tighten the fuel leak-off pipe (3) to the fuel supply pump (4).

NOTE: Tighten the fuel feed pipe together.

 CAUTION: Use new gaskets.

4. Securely tighten the fuel leak-off pipe (3) to the cylinder head assembly (2).

Tightening torque: **12 N·m (106.2 lb in)**

5. Securely tighten the fuel leak-off pipe (3) to the common rail assembly (1).

Tightening torque: **24 N·m (17.7 lb ft)**

6. Securely tighten the fuel leak-off pipe (3) to the fuel supply pump (4).

Tightening torque: **24 N·m (212.4 lb in)**

7. Install the clip to the fuel leak-off pipe (3).

Tightening torque: **8 N·m (70.8 lb in)**

Fuel pipe Installation

1. Install the fuel pipe to the fuel supply pump and the common rail assembly.

Tightening torque: **44 N·m (32.5 lb ft)**

 CAUTION: Use new gasket.

2. Install the clip to the bracket.

Tightening torque: **9.0 N·m (79.7 lb in)**

Engine harness connect

1. Connect the engine harness to the engine assembly.

NOTE: Connect each connector.

Battery ground cable connect

1. Connect the battery ground cable to the battery.

Fuel air bleed

Refer to the **Fuel injection system - Bleed (10.218)**.

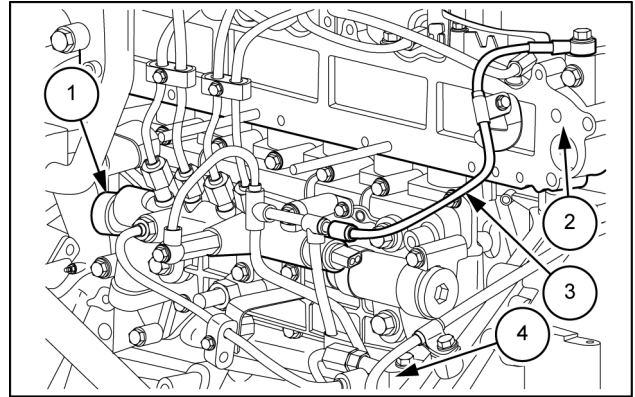

SMIL14CEX5652AB 7

Turbocharger - Install

Turbocharger assembly installation

1. Temporarily tighten the turbocharger assembly (2) to the exhaust manifold (1).

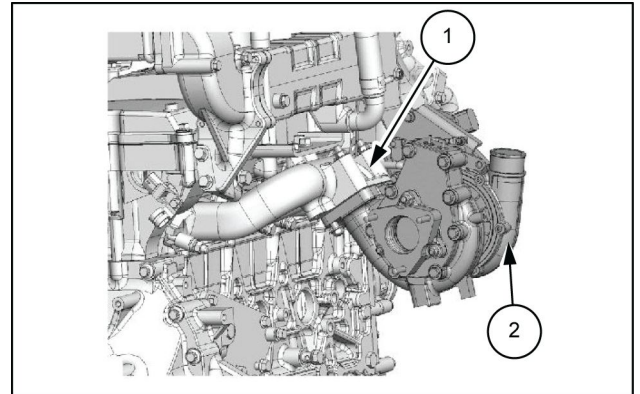

SMIL13CEX1817AB 1

2. Temporarily tighten the exhaust manifold stay (3) to the cylinder block and the turbocharger assembly (1).
2. Exhaust manifold

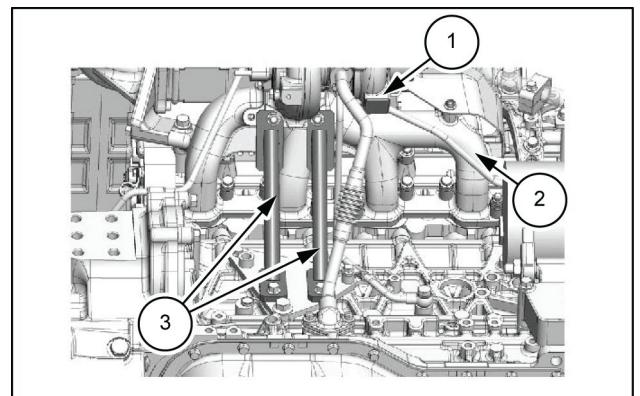

SMIL13CEX1818AB 2

3. Securely tighten the turbocharger assembly to the exhaust manifold.

Tightening torque: **52 N·m (38 lb ft)**

4. Securely tighten the exhaust manifold stay to the cylinder block and the turbocharger assembly.

Tightening torque: **52 N·m (38 lb ft)** nut

Tightening torque: **50 N·m (37 lb ft)** bolt

NOTE: Tightening order.

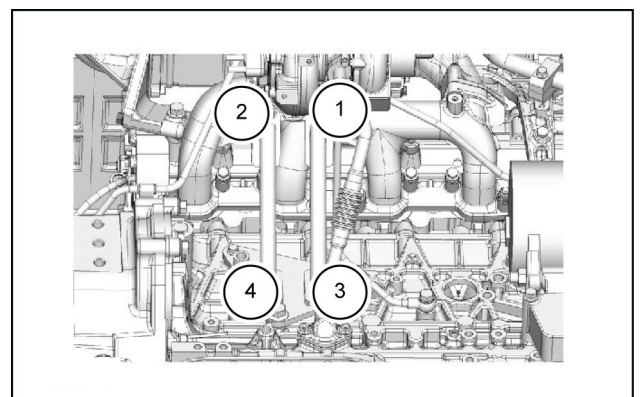

SMIL13CEX1819AB 3

Exhaust manifold removal

1. Remove the exhaust manifold brackets **(3)** and **(4)** from the exhaust manifold **(5)**.
2. Remove the exhaust manifold **(5)** from the cylinder head assembly.
3. Remove the exhaust manifold brackets **(3)** and **(4)** from the cylinder head assembly.
 1. Distance tube
 2. Washer

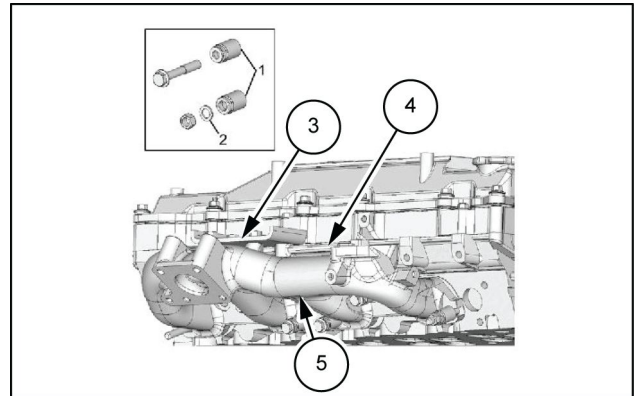

SMIL13CEX1402AB 13



Engine - 10

**Exhaust Gas Recirculation (EGR) - Diesel Particulate Filter (DPF)
exhaust treatment - 501**

**CX250D Crawler excavators LC version (TIER4 FINAL) - NA Market
CX250D Long Reach Crawler excavators LC Long Reach (TIER4 FINAL)
- NA Market**

8. Remove the drain plug (1) and then loosen the hose band (2) to disconnect the hose (3).

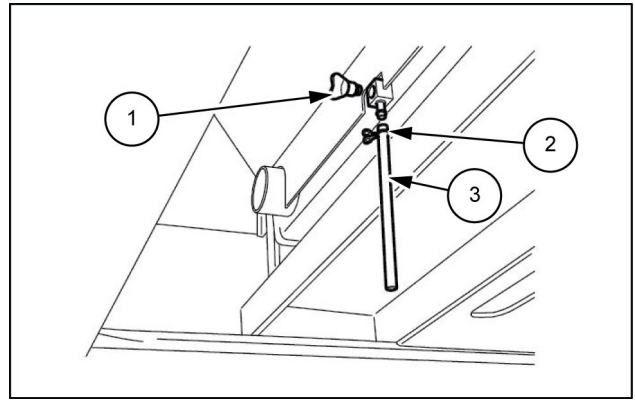

SMIL13CEX1266AB 8

9. Loosen the hose band (2) to disconnect the hose (1) of the radiator cap.

NOTE: Attach caps and plugs at the hoses so as to prevent invasion of water, dust and dirt.

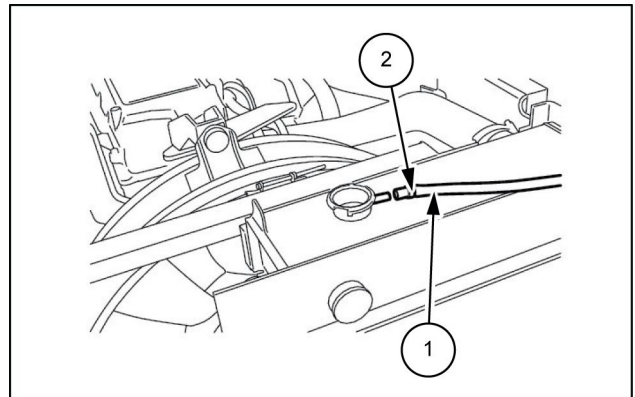

SMIL13CEX1267AB 9

10. Remove the 3 bolts (1) with a wrench [14 mm] to remove the bracket (2).

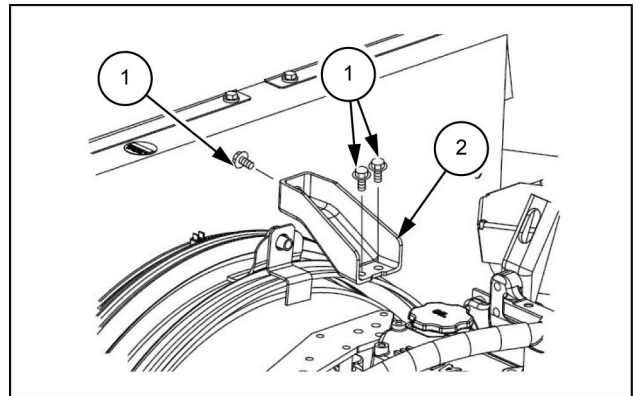

SMIL13CEX1268AB 10

11. Remove the 2 bolts (1) with a wrench [14 mm] to remove the fan guard (2).

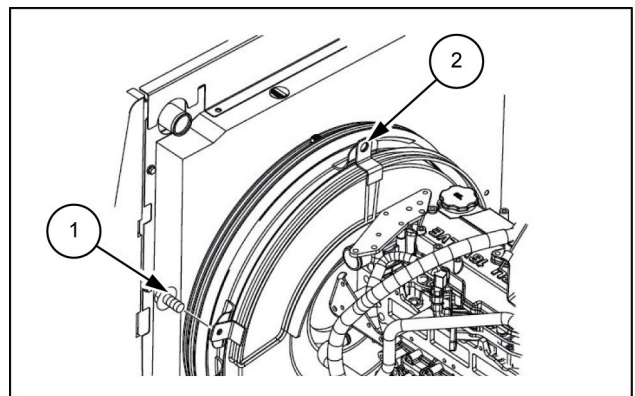

SMIL13CEX1269AB 11

Engine oil pump - Component identification

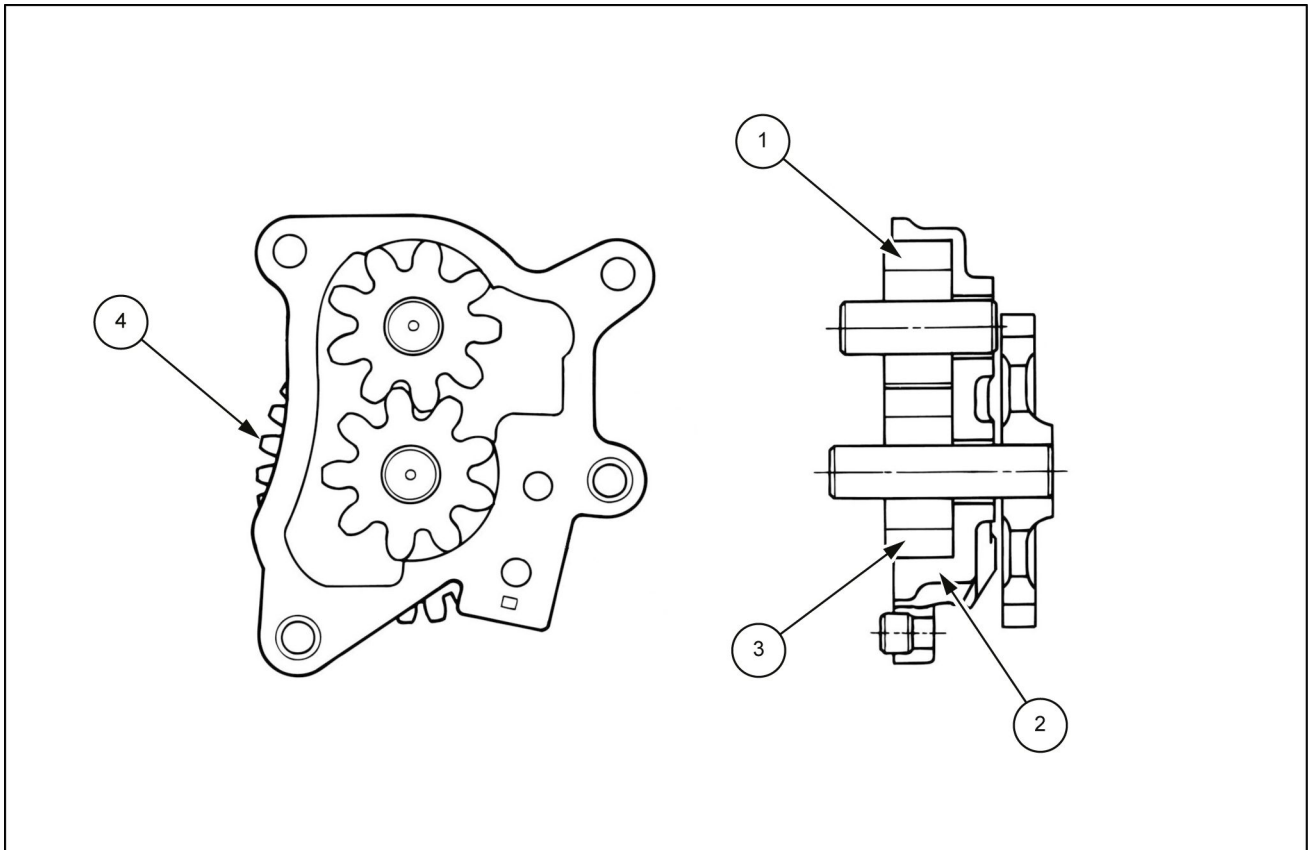

SMIL14CEX3885FB 1

- | | |
|-------------------------|------------------------|
| 1. Driven gear assembly | 3. Drive gear assembly |
| 2. Oil pump body | 4. Oil pump drive gear |

Rocker arm shaft adjustment

Valve clearance adjustment

CAUTION:

- Adjust the valve clearance while cool.
- Loosen all adjust screws before adjustment.

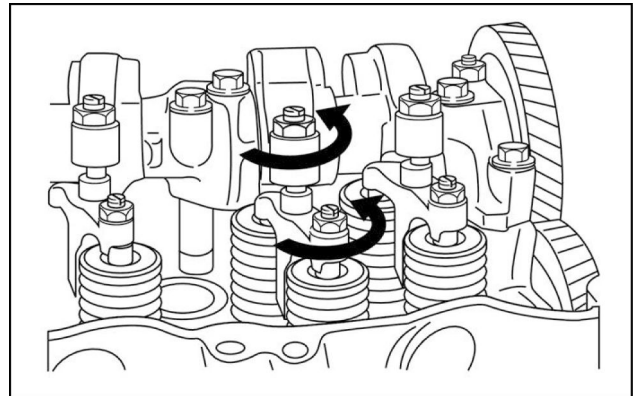

SMIL14CEX3082AA 31

1. Align No. 1 cylinder to the compression top dead center.

1. Front cover marking
2. 0° marking on the crankshaft damper

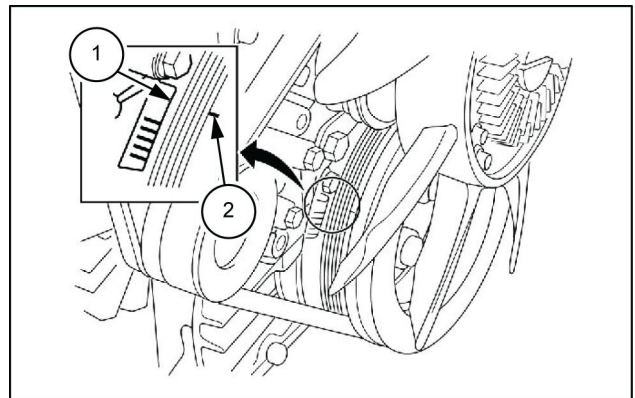

SMIL13CEX1690AB 32

2. Prepare the feeler gauge.

Thickness: **0.4 mm (0.0157 in)** 2 pieces

NOTE: Insert the thickness gauge between the rocker arm and bridge cap.

NOTE: Insert the thickness gauge between the bridge and valve.

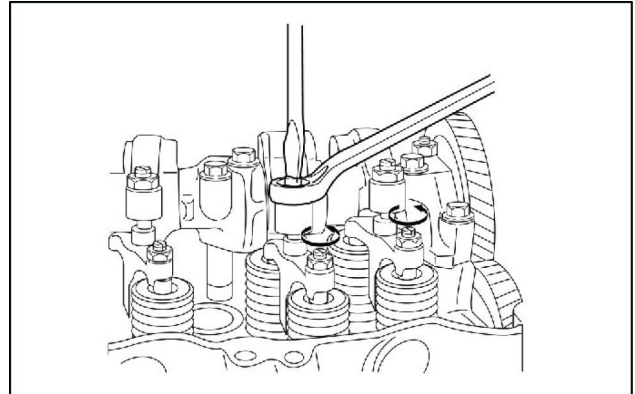

SMIL13CEX1691AA 33

3. Turn the adjust screw.

NOTE: When the movement of the thickness gauge becomes stiff, secure the adjust screw nut of the rocker arm.

Tightening torque: **22 N·m (16 lb ft)**



Hydraulic systems - 35

Hydraulic systems - 000

CX250D Crawler excavators LC version (TIER4 FINAL) - NA Market
CX250D Long Reach Crawler excavators LC Long Reach (TIER4 FINAL)
- NA Market

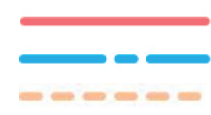

Pressure line

Tank line

Pilot pressure line



Pilot tank line

Electric line

1. Swing motor
2. Cushion valve
3. Right swing
4. Left swing
5. Swing pilot pressure sensor
6. Remote control valve (arm, swing)
7. Check valve
8. Oil cooler

9. Lever lock
10. Swing brake
11. 5 stack solenoid valve
12. Console lever lock switch
13. Main computer
14. Control valve
15. Hydraulic pump
16. Key switch

ARM SEMI-PARALLEL 1 CIRCUIT

Purpose

Reduces the pressure drops while the oil flows into the arm via P1 parallel path (mainly during a compound operation).
Secures the swing pressure during an arm + swing compound operation and improves leveling operability.

Independent operation

By operating the remote control valve to the arm-out or arm-in side, the pilot pressure oil is fed via the cushion valve to the control valve pa5 (pa9) or pb5 (pb9) port and switches the arm **(1)** and **(2)** spools to the out or in side.

The discharge oil from hydraulic pump A1 enters the control valve P1 port and is fed from the center bypass oil path to the arm **(1)** spool.

The discharge oil from the hydraulic pump A2 enters the control valve P2 port, flows from the center bypass oil path and through the arm oil merging path before the arm **(2)** spool, and merges downstream of the arm **(1)** spool.

The arm **(1)** parallel spool operates according to the pilot pressure for an arm open/close operation.

- The opening is changed by increasing or decreasing the pilot pressure.

The pressure oil that passes through the parallel path flows through the arm **(1)** parallel spool, then to the arm **(1)** spool.

Switching the arm spool lets the oil flow through the load holding valve check valve and into the arm cylinder rod side, carrying out the arm-out operation. (for opening)

Switching the arm spool lets the oil flow into the arm cylinder bottom side and the arm-in operation is carried out. (for closing)

The arm cylinder bottom side return oil goes through the arm **(1)** and **(2)** spools and returns to the hydraulic tank.

The arm cylinder rod side return oil goes through the arm **(1)** spool and returns to the hydraulic tank. Compound operation (+ swing operation)

By operating the remote control valve to the arm-out or arm-in side, the pilot pressure oil is fed via the cushion valve to the control valve pa5 (pa9) or pb5 (pb9) port and switches the arm **(1)** and **(2)** spools to the out or in side.

By operating the remote control valve to the swing side at the same time, the pilot pressure oil is fed via the cushion valve to the control valve pa3 or pb3 port and switches the swing spool. The discharge oil from the hydraulic pump A1 enters the control valve P1 port and is fed from the center bypass oil path to the swing spool.

The pressure oil that passes through the parallel circuit flows through the arm **(1)** parallel spool and is fed to the arm **(1)** spool.

The discharge oil from the hydraulic pump A2 enters the control valve P2 port, flows from the center bypass oil path and through the arm oil merging path before the arm **(2)** spool, and merges downstream of the arm **(1)** spool. If a swing operation is performed during an arm open/close operation (during a compound operation), the arm **(1)** parallel spool operates according to the pilot pressure.

- The opening is changed by increasing or decreasing the pilot pressure. When the swing pilot pressure increases, the opening of the arm **(1)** parallel spool narrows to secure the pressure for swing operations.

Secures the swing acceleration pressure during an arm + swing compound operation (same for swing press digging).

Switching the arm spool lets the oil flow through the load holding valve check valve and into the arm cylinder rod side, carrying out the arm-out operation. (for opening)

Switching the arm spool lets the oil flow into the arm cylinder bottom side and the arm-in operation is carried out. (for closing)

The swing operation is carried out by switching the swing spool. Compound operation (arm in + boom up)

By operating the remote control valve to the arm-in side, the pilot pressure oil is fed via the cushion valve to the control valve pb5 (pb9) port and switches the arm **(1)** and **(2)** spools to the in side.

By operating the remote control valve to the boom-up side at the same time, the pilot pressure oil is fed via the cushion valve to the control valve pa4 port and switches the boom **(1)** and **(2)** spools.

The discharge oil from the hydraulic pump A1 enters the control valve P1 port and is fed from the center bypass oil path to the boom **(2)** spool.

The pressure oil that passes through the parallel circuit flows through the arm **(1)** parallel spool and is fed to the arm **(1)** spool.

The discharge oil from hydraulic pump A2 enters the control valve P2 port and is fed from the center bypass oil path to the boom **(1)** spool.

The pressure oil that passes through the parallel circuit flows through the arm **(2)** parallel spool and is fed to the arm **(2)** spool.

The oil passes through the arm oil merging path before the arm **(2)** spool and merges downstream of the arm **(1)** spool.

During an arm digging operation, the opening of the arm **(1)** parallel spool opens.

- The opening is changed by increasing or decreasing the pilot pressure. The opening of the arm **(1)** parallel spool is closed when the arm digging operation is completed and boom-up operation is carried out.

This is to secure the boom-up responsiveness in the latter half of the digging operation.

Switching the arm spool lets the oil flow into the arm cylinder bottom side and the arm-in operation is carried out.

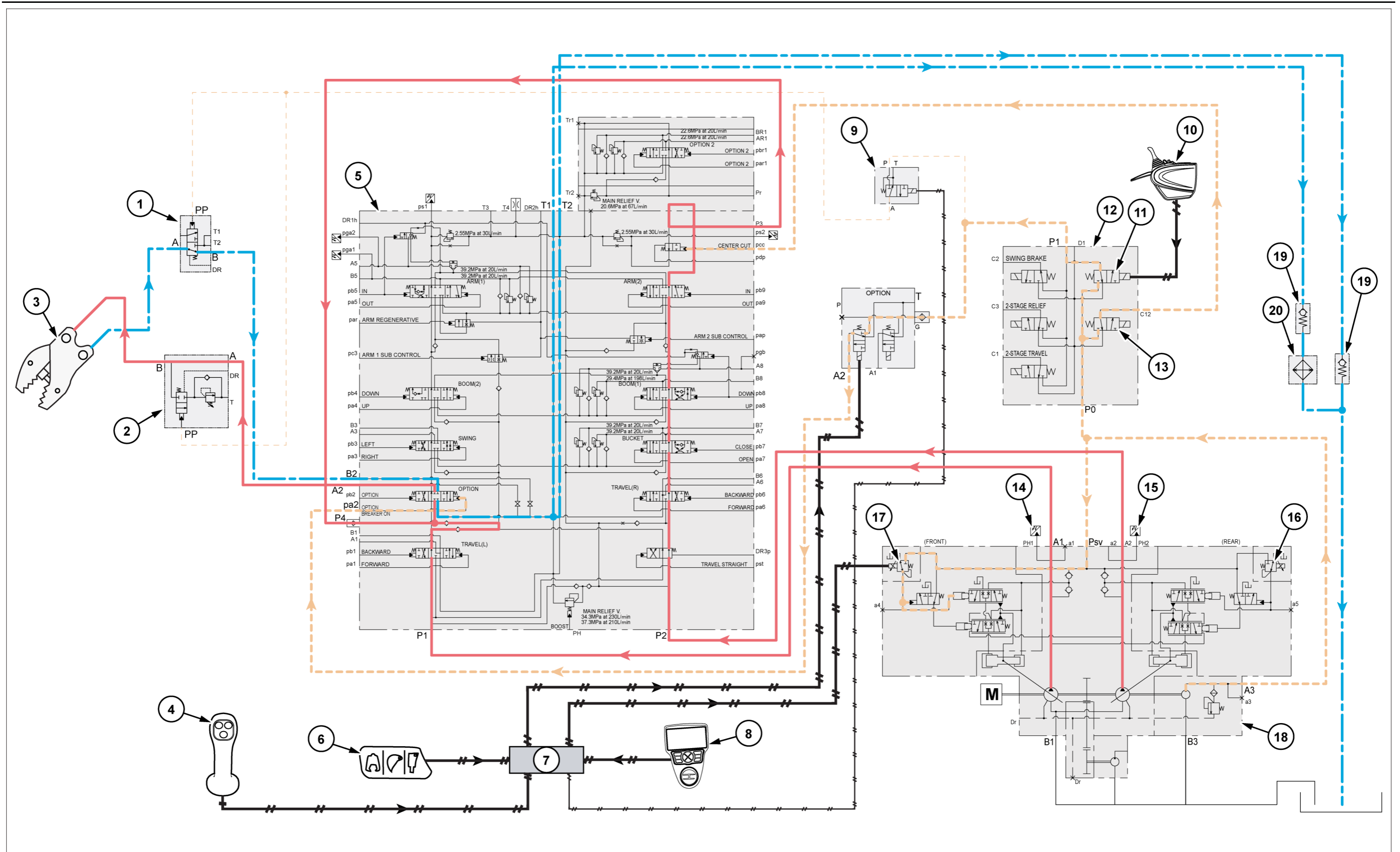

SMIL15CEX0324JB 4



Pressure line



Tank line



Pilot pressure line



Pilot tank line



Electric line

1. Swing motor
2. Cushion valve
3. Right swing
4. Left swing
5. Swing pilot pressure sensor
6. Remote control valve (arm, swing)
7. Swing
8. Lever lock

9. Main computer
10. 5 stack solenoid valve
11. Console lever lock switch
12. Main computer
13. Control valve
14. Hydraulic pump
15. Check valve
16. Oil cooler

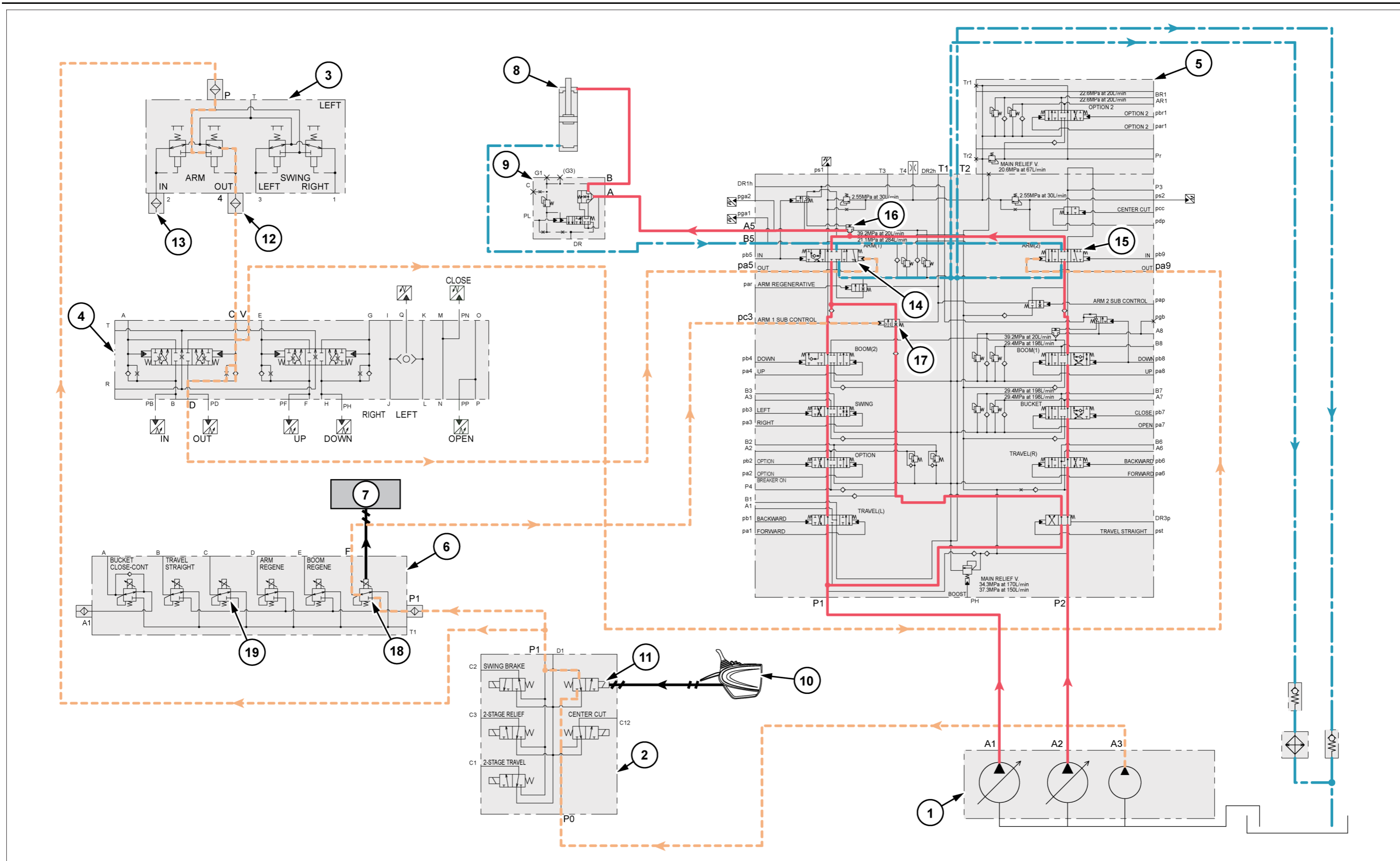

SM115CEX0308JB 2

(b) 6 m (19.69 ft) travel

OFF TRAVEL AMOUNT

Measurement method

1. Engine high idle and oil temperature is **45 - 55 °C (113 - 131 °F)** with no load.
2. Measure the required time to travel **20 m (65.62 ft)** after a **4 - 5 m (13.12 - 16.40 ft)** running start.
3. Shoe tension amount should be standard for right and left.
4. Measure for both forward and backward traveling.
5. Measure for both high-speed and low speed traveling.

(a) Off travel amount

(b) Reference line

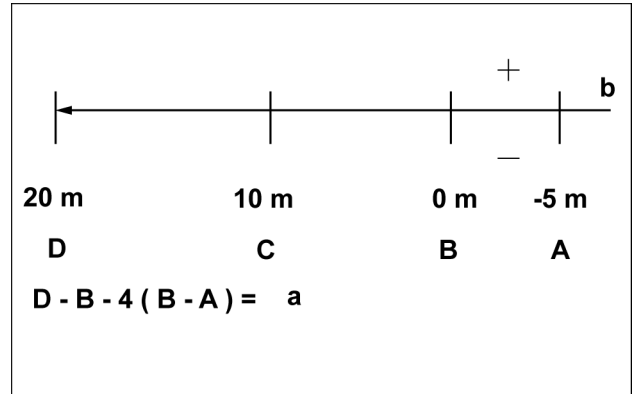

SMIL14CEX6650BA 10

NOTE: Same posture of the travel speed measurement.

TRAVEL SPROCKET SPEED

Measurement method

1. Engine at high idle.
2. Oil temperature is at **45 - 55 °C (113 - 131 °F)**.
3. Raise the shoe and wait until the steady rotation speed is reached, measure the time needed to complete 10 rotations of the sprocket for both forward travel and backward travel.
4. Measure for both the high-speed mode and low-speed mode.

NOTE: Swing by **90 °** to raise the shoe.

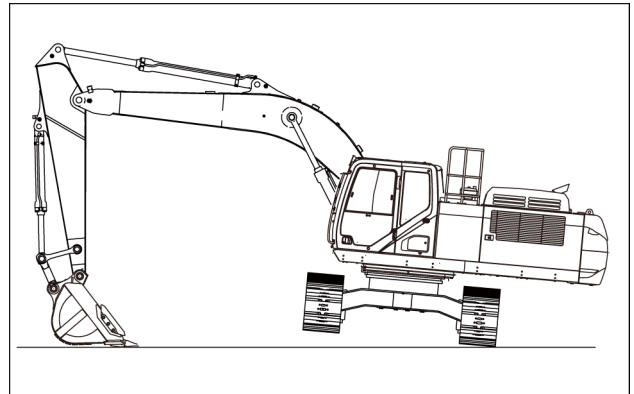

SMIL14CEX6651BA 11

Travel motor

1. Remove the bolts (2), then remove the cover (1).
Tightening torque for bolt installation: **63.7 - 73.5 N·m**
(**47.0 - 54.2 lb ft**).

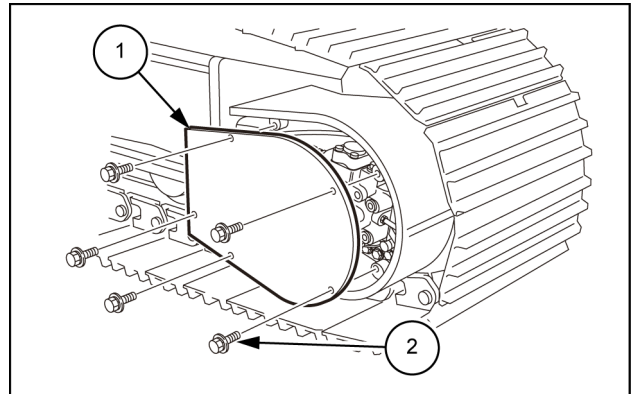

SMIL14CEX2123AB 2

2. Use a hexagon wrench (6 mm) (1) to remove the air bleed plug (2) as in the figure on the left.

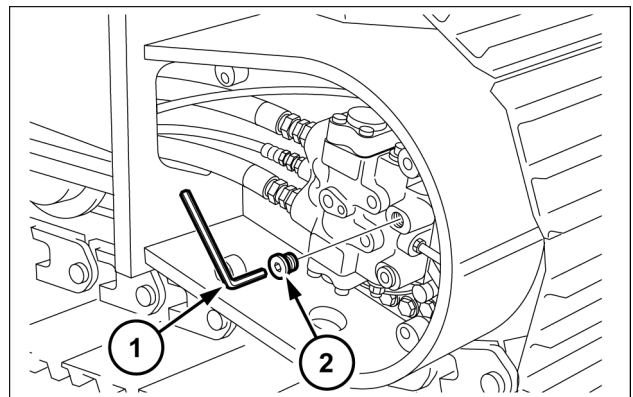

SMIL14CEX5095AB 3

3. Pour in about **500 cm³** of hydraulic oil (1) from the air bleed port. When inside the motor is filled with hydraulic oil (1), tighten the air bleed plug.
4. When the motor is filled with hydraulic oil (1), tighten the air bleed plug.
5. Start the engine and execute a slow travel operation.
6. Repeatedly traveling forward and backward bleeds off the air.

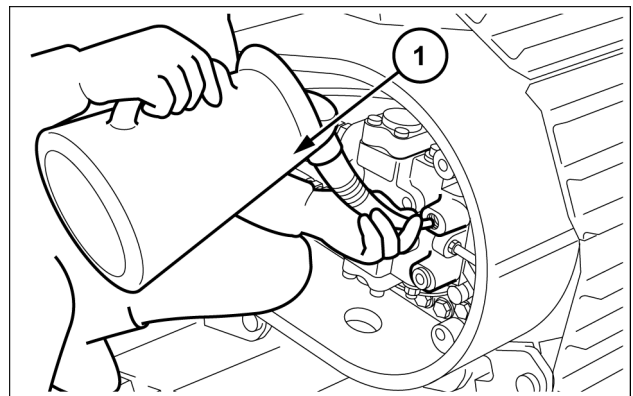

SMIL14CEX5096AB 4

Swing motor

1. Run the engine at low idle, loosen the tee (1) of drain hose (3), and check that oil oozes from the air bleed port section (2).

NOTE: Do not execute a swing operation.

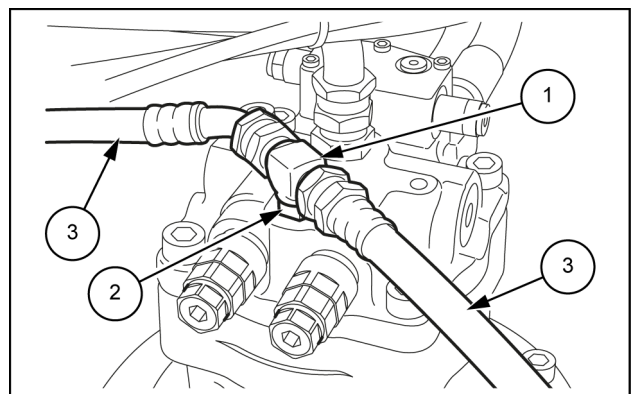

SMIL14CEX2135AB 5

13. Pull out the pump outward in axial direction with a liftcrane and nylon sling **(1)** and then lift the pump.

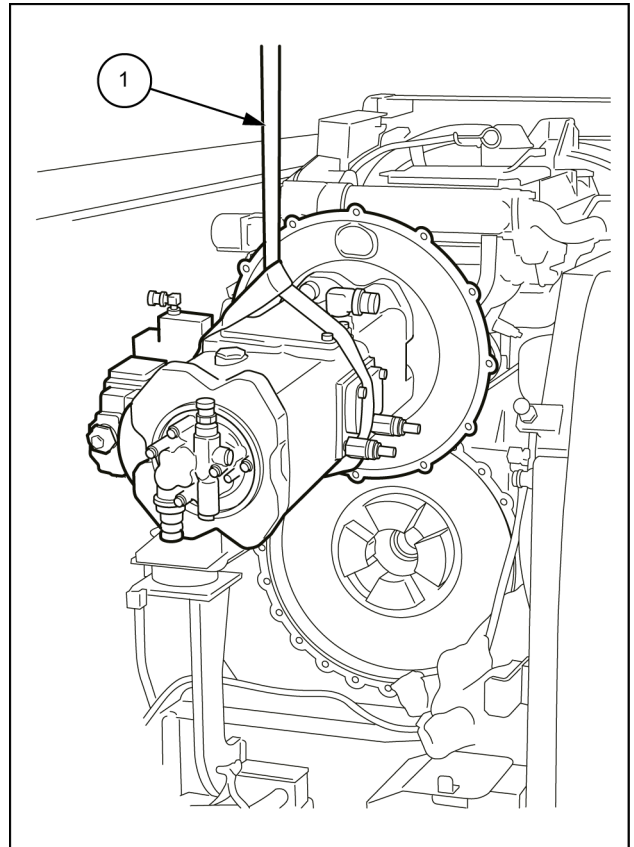

SMIL14CEX1324BB 10

14. Make sure that you have a safe site, and then settle the pump on a wood plank **(1)** or other block.
- Make sure to secure the pump so as to prevent it from falling.

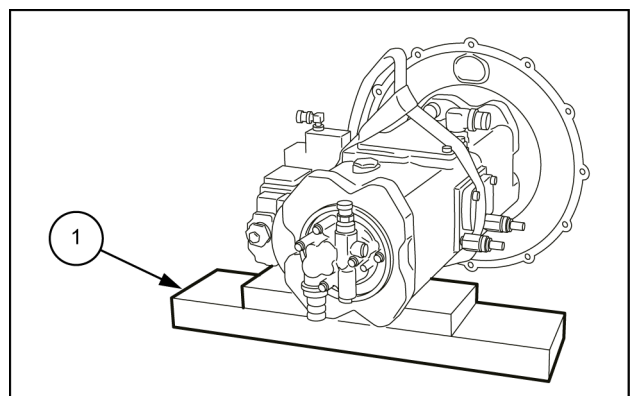

SMIL14CEX1325AB 11

Pump control valve - Prepare

1. The regulator is configured by precision components; therefore, disassembly and assembly require somewhat complicated procedures.
2. The regulators at the front side and the rear side use different pressure - flow sets. Mark each component before disassembly, so distinguishing front side and rear side components become possible.
3. Read the disassembly procedure thoroughly and take the following procedures when disassembling the regulator.

Numbers in parentheses following the component names indicate codes in the **Pump control valve - Sectional view (35.102)**.

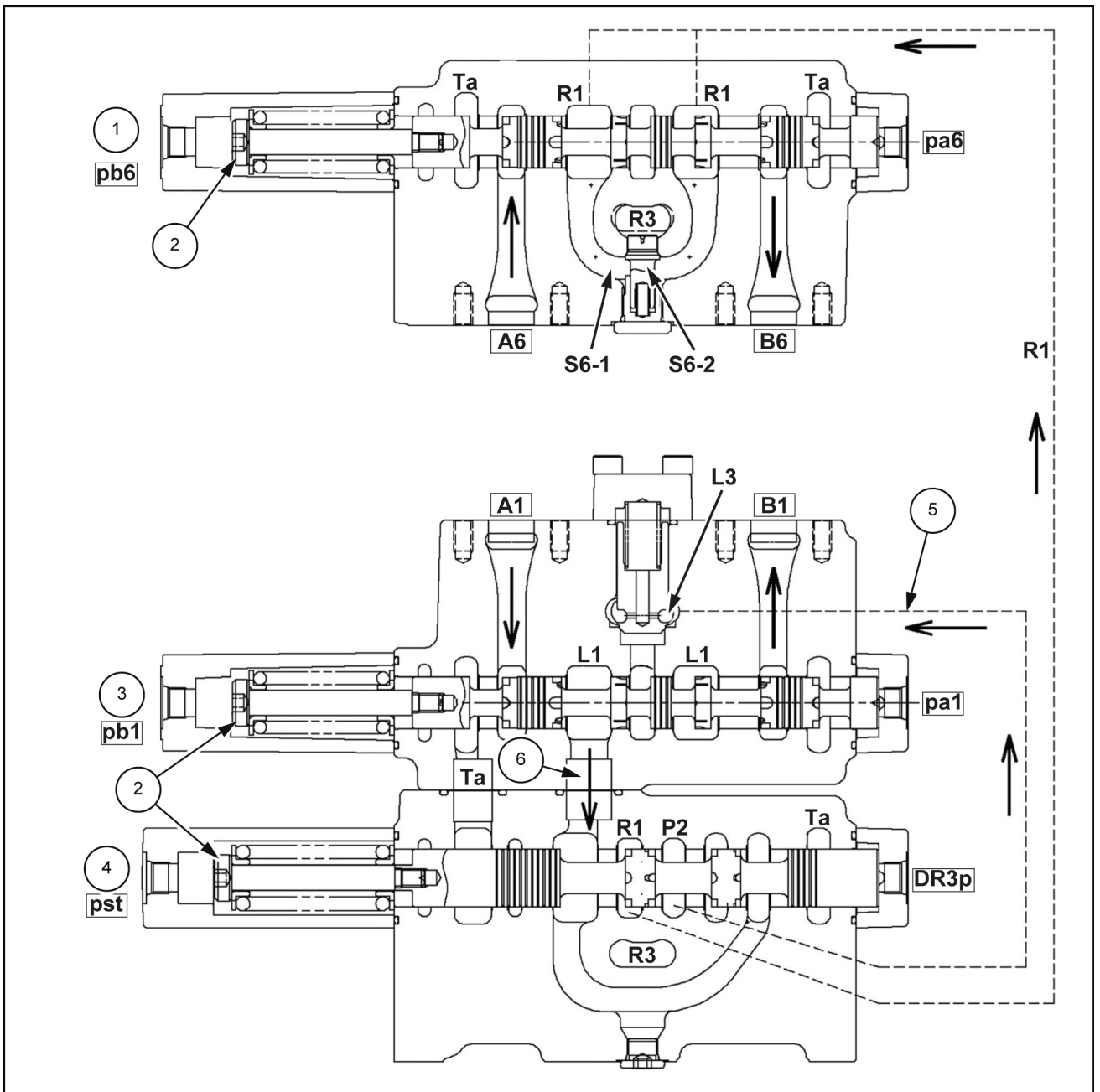

SMIL14CEX3823GB 21

- | | |
|-----------------------|---------------------------------|
| 1. Travel (section 6) | 4. Travel straight (section ST) |
| 2. Switchover state | 5. Path 1 |
| 3. Travel (section 1) | 6. Path 3 |

4. Antidrift valve [Fig. 22 - 24]

The antidrift valve is installed at the cylinder port of the arm rod (boom head) side in order to prevent self-dropping of the arm (boom) cylinder.

It is also activated by leading relief signal from the pilot signal via the internal path. (Arm side **(A5)** is shown as representative example)

Stacked control valves - Assemble

Caution for handling O-ring

1. Do not use any O-ring with defect in formation or with damage during handling.
2. Thoroughly lubricate the O-ring and the O-ring mounting section with grease or hydraulic fluid to allow smooth installation.
3. Do not expand the O-ring to cause permanent deformation.
4. Pay attention not to roll in the O-ring when assembling it.
(Twisted O-ring may not easily return its twist after installation and may cause oil leak.)

Caution for handling spool

1. Make sure to obey the specified torque since excessive torque applied to the thread section may cause operation failure of the spool.
2. Pay attention to keep the same combination of each spool, the spring and the spool end before and after disassembly.

Method to apply adhesive agent (male and female thread section of components requiring bonding)

1. Cleaning (de-greasing)
Clean using steam de-greasing with acetate or ether, or using alkaline cleaning agent.
2. Drying
Dry out bonded surface by blowing clean air or leave it to dry out by itself.
Insufficient drying out may cause deteriorated bonding effect.
3. Applying adhesive agent
Apply a little amount of adhesive agent (**LOCTITE® 638™** or equivalent) on a couple of pitches of female thread on entry end of the spool.
During this work, pay attention not to touch the applied portion to the spring seat.

 **CAUTION:** Do not use the “Loctite primer T” hardening promoter agent in order to avoid deteriorating bonding strength.

Undercarriage solenoid valve - Prepare - 5 Stack solenoid valve

⚠ WARNING

Escaping fluid!

Hydraulic fluid or diesel fuel leaking under pressure can penetrate the skin and cause infection or other injury. To prevent personal injury: Relieve all pressure before disconnecting fluid lines or performing work on the hydraulic system. Before applying pressure, make sure all connections are tight and all components are in good condition. Never use your hand to check for suspected leaks under pressure. Use a piece of cardboard or wood for this purpose. If injured by leaking fluid, see your doctor immediately.

Failure to comply could result in death or serious injury.

W0178A

⚠ WARNING

Avoid injury!

Shut off the engine, remove the key, and make sure all motion is stopped before servicing the machine.

Failure to comply could result in death or serious injury.

W1128A

Items to prepare:

- Wrenches [13 mm, 17 mm, 19 mm, 22 mm]
- Marking pen
- Cap
- Plug
- Rag
- Cleaning fluid

During cushion operation

When the pressure oil being supplied from the pilot operation valve to the port A (or the port C, E, G) is interrupted by the pilot operation valve, the pressure oil acting on the spool of the control valve will be pushed back to the port B (or the port D, F, H) by the return spring of the spool.

The returned oil is sent to the port A (or the port C, E, G) through the orifice in the check plunger, and drained from the pilot operation valve.

At this time, since it passes through the orifice, the spool speed of the control valve is controlled to prevent the actuator from stopping suddenly, thereby reducing the shaking of the vehicle. (Cushion function)

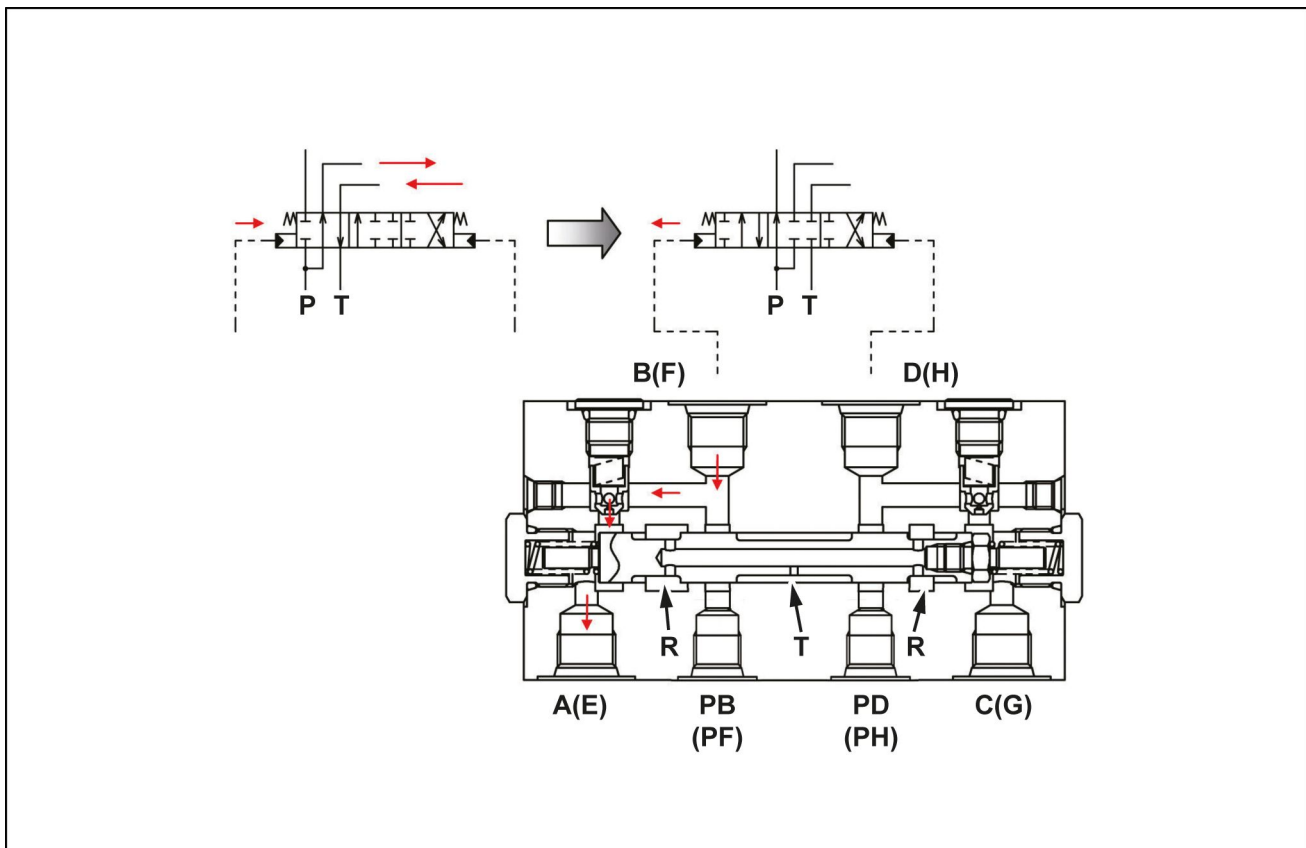

SMIL14CEX3858FA 3

Cushion valve - Prepare

⚠ WARNING

Escaping fluid!

Hydraulic fluid or diesel fuel leaking under pressure can penetrate the skin and cause infection or other injury. To prevent personal injury: Relieve all pressure before disconnecting fluid lines or performing work on the hydraulic system. Before applying pressure, make sure all connections are tight and all components are in good condition. Never use your hand to check for suspected leaks under pressure. Use a piece of cardboard or wood for this purpose. If injured by leaking fluid, see your doctor immediately.

Failure to comply could result in death or serious injury.

W0178A

⚠ WARNING

Avoid injury!

Shut off the engine, remove the key, and make sure all motion is stopped before servicing the machine.

Failure to comply could result in death or serious injury.

W1128A

Items to prepare:

- Wrenches [17 mm, 19 mm, 22 mm]
- Hexagon wrench [5 mm]
- Marking pen
- Cap
- Plug
- Waste oil can
- Rag
- Cleaning fluid

13. Use the hexagon wrench to remove the hexagon socket head bolts (1).

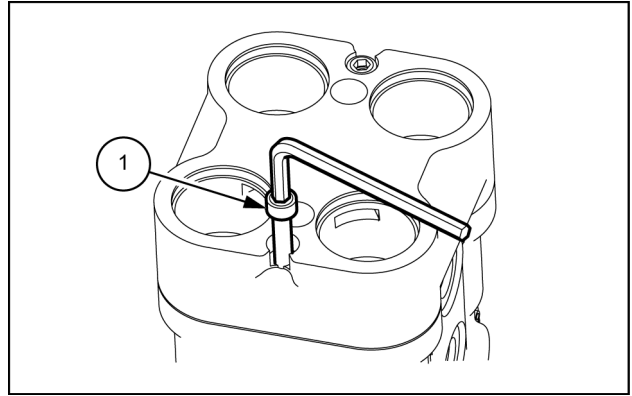

SMIL14CEX1461AB 13

14. Remove the damper casing (1) and remove the O-rings (4) and (3) from the casing.

- Record the positions of the damper casing in relation to the casing (2).
- Be careful when removing parts, as the pressure reducing valve assembly may fly off due to the return springs.

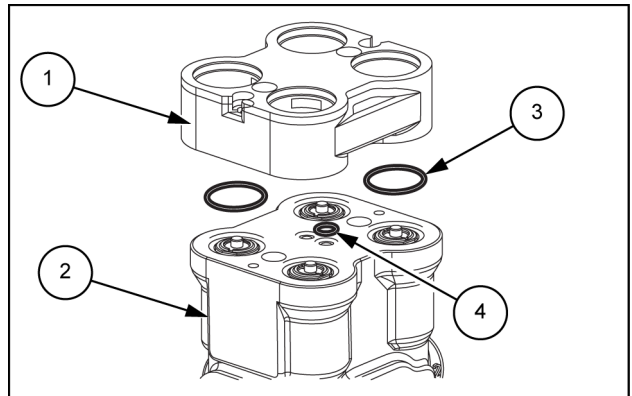

SMIL14CEX1462AB 14

15. Remove the pressure reducing valve assemblies (1) from the casing (2).

- Record the positions of these parts in relation to the casing holes.

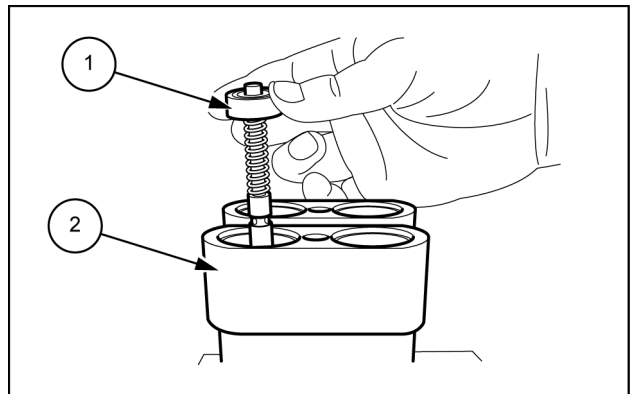

SMIL14CEX1463AB 15

16. Remove the return springs (1) from the casing (2).

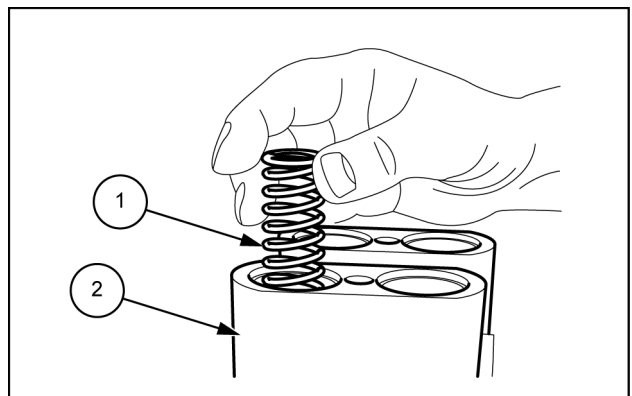

SMIL14CEX1464AB 16

Swing reduction gear - Exploded view

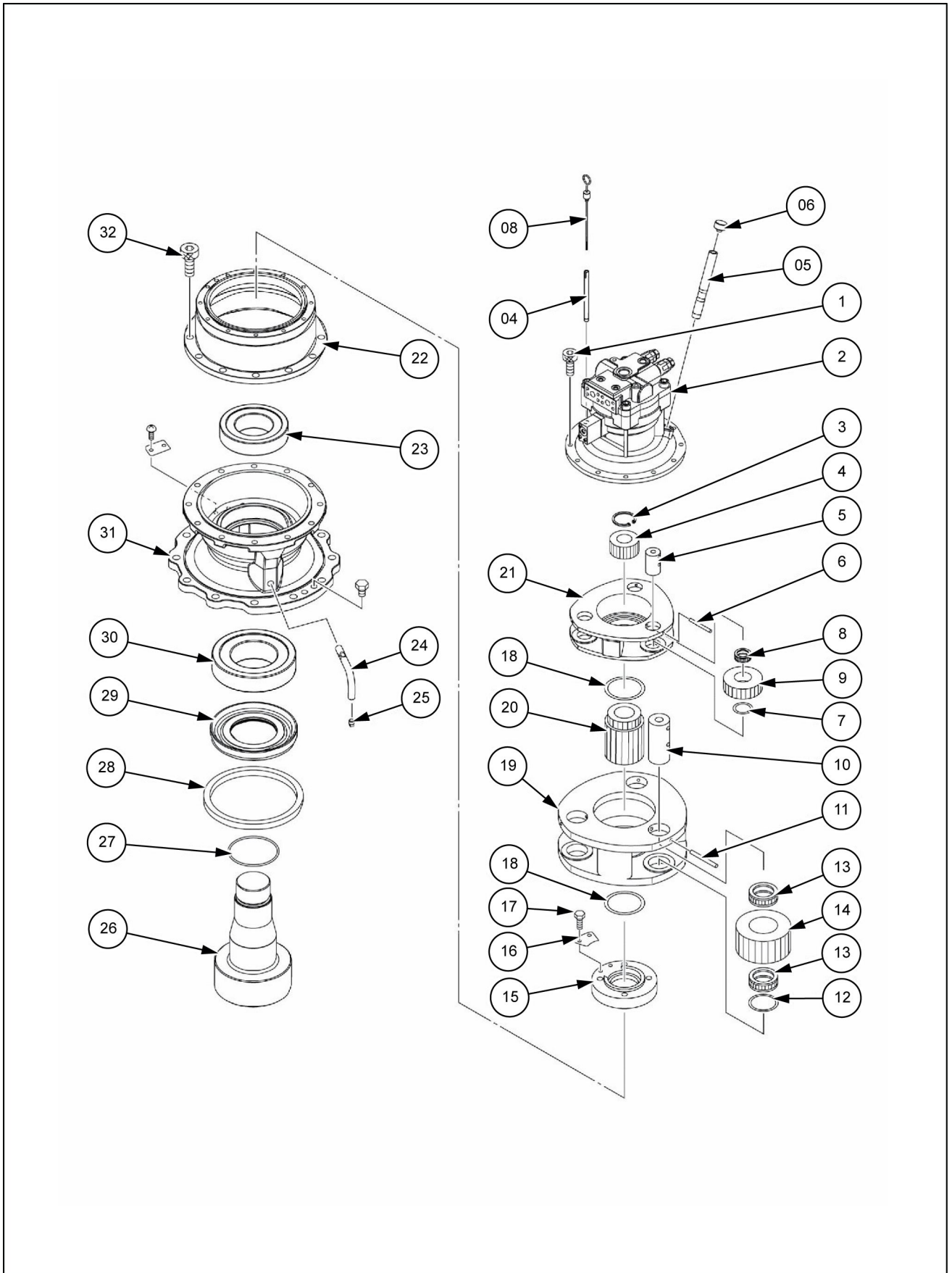

SMIL13CEX2805HB 1

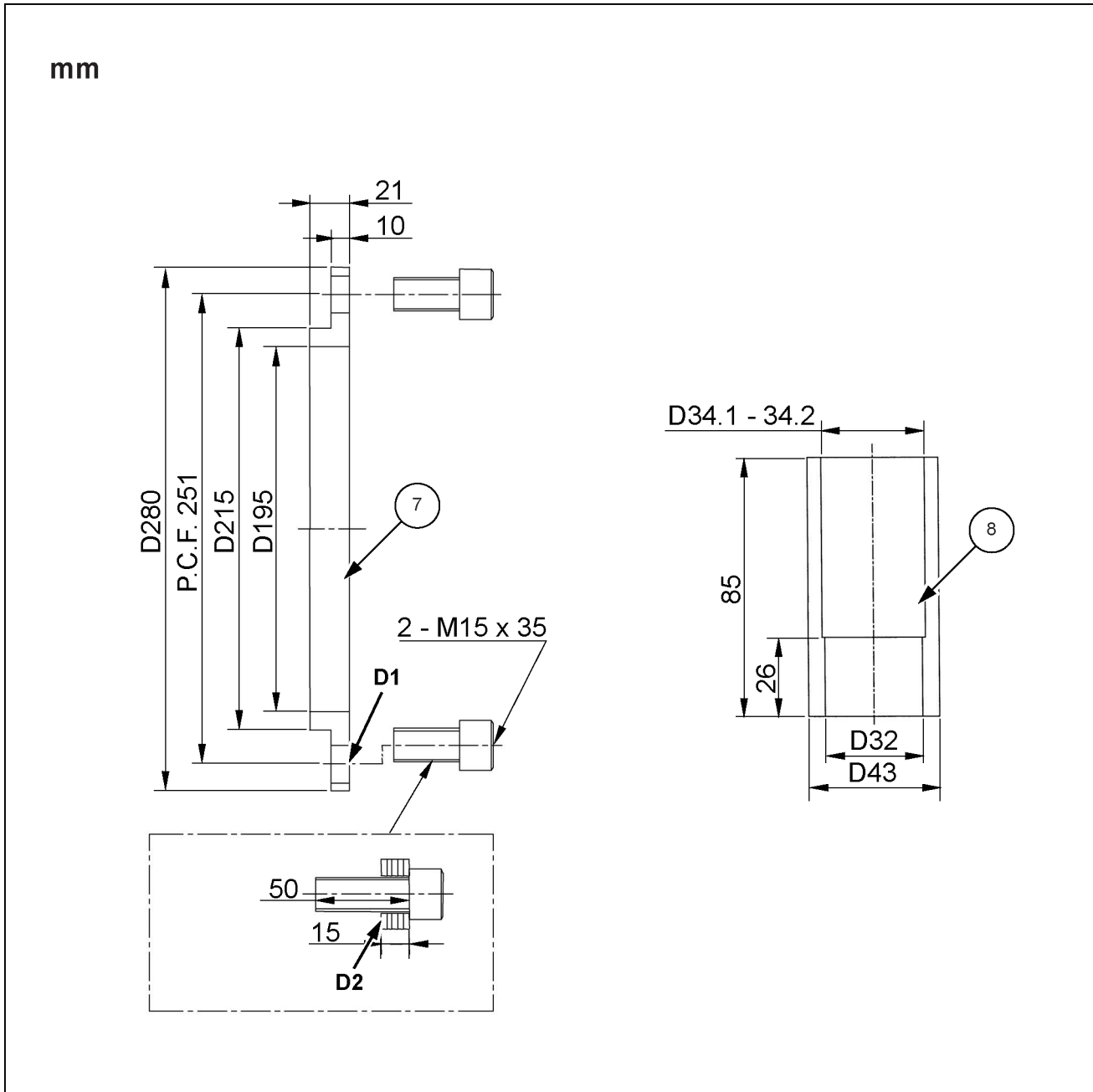

SMIL14CEX2936GB 2

NOTE: All the dimensions in figure are in mm.

Code	Order No.	Jig name	Remarks
7		Brake piston insertion jig	
8		Piston and shoe measurement jig	When the rear cover bolts are used as is: D1: 2-20 drill, D2: 10 - Plain flat washer with rounded finish 18 mm

Parts table

Code	Part name	Code	Part name
1	Piston motor (Quantity 1)	1-8	Ball bearing (Quantity 1)
1-1	Flange (Quantity 1)	1-9	Ball bearing (Quantity 1)
1-2	Base plate assembly (Quantity 1)	1-10	Pin (Quantity 1)
1-2-1	Base plate (Quantity 1)	1-11	Hexagon socket head bolt (Quantity 10)
1-2-2	Spool assembly (Quantity 1)	1-12	Oil seal (Quantity 1)
1-2-2-1	Spool (Quantity 1)	1-13	Disk plate (Quantity 3)
1-2-2-2	Check valve (Quantity 2)	1-14	Friction plate (Quantity 2)
1-2-2-3	Spring (Quantity 2)	1-15	Brake piston (Quantity 1)
1-2-2-4	Plug (Quantity 2)	1-16	D-ring (Quantity 1)
1-2-2-5	O-ring (Quantity 2)	1-17	D-ring (Quantity 1)
1-2-3	Spring seat (Quantity 2)	1-18	Spring (Quantity 8)
1-2-4	Spring (Quantity 2)	1-19	Pin (Quantity 4)
1-2-5	Cap (Quantity 2)	1-20	Spring (Quantity 2)
1-2-6	O-ring (Quantity 2)	1-21	Valve plate (Quantity 1)
1-2-7	Relief valve assembly (Quantity 2)	1-22	O-ring (Quantity 4)
1-2-7-1	Relief housing (Quantity 1)	1-23	O-ring (Quantity 1)
1-2-7-2	Poppet (Quantity 1)	1-24	Nameplate (Quantity 1)
1-2-7-3	Poppet seat (Quantity 1)	1-25	Rivet (Quantity 2)
1-2-7-4	Spring seat (Quantity 1)	1-26	Plug (Quantity 2)
1-2-7-5	Spring (Quantity 1)	1-27	Plug (Quantity 1)
1-2-7-6	Plug (Quantity 1)	1-28	Plug (Quantity 1)
1-2-7-7	O-ring (Quantity 1)	2	Floating seal (Quantity 2)
1-2-7-9	Free piston (Quantity 1)	3	Angular bearing (Quantity 2)
1-2-7-10	O-ring (Quantity 1)	4	Housing (Quantity 1)
1-2-7-11	Backup ring (Quantity 2)	5 *	Shim t = 0.05 mm (0.002 in) (Quantity 1)
1-2-7-13	Spring guide (Quantity 1)	5 *	Shim t = 0.1 mm (0.004 in) (Quantity 1)
1-2-7-14	O-ring (Quantity 1)	5 *	Shim t = 0.3 mm (0.012 in) (Quantity 1)
1-2-7-15	Locking screw (Quantity 1)	5 *	Shim t = 0.5 mm (0.020 in) (Quantity 1)
1-2-7-16	Nut (Quantity 1)	5 *	Shim t = 1.0 mm (0.039 in) (Quantity 1)
1-2-7-17	O-ring (Quantity 1)	6	Holder C (Quantity 1)
1-2-7-18	Backup ring (Quantity 2)	7	Washer (Quantity 8)
1-2-8	Plug (Quantity 8)	8	Bolt (Quantity 8)
1-2-9	Spool assembly (Quantity 1)	9	Thrust plate (Quantity 4)
1-2-9-1	Spool A (Quantity 1)	10	Inner race (Quantity 4)
1-2-9-2	Spool C (Quantity 1)	11	Needle bearing (Quantity 4)
1-2-10	Spring (Quantity 1)	12	Planetary gear C (Quantity 4)
1-2-11	Plug (Quantity 1)	13	Thrust plate (Quantity 4)
1-2-12	O-ring (Quantity 2)	14	Bolt (Quantity 4)
1-2-13	Spring guide (Quantity 1)	15	Sun gear C (Quantity 1)
1-2-14	Plug (Quantity 1)	16	Snap ring (Quantity 1)
1-2-19	Orifice (Quantity 2)	17	Holder B (Quantity 1)
1-2-20	Plug (Quantity 5)	18	Thrust plate (Quantity 3)
1-2-21	O-ring (Quantity 5)	19	Inner race (Quantity 3)
1-2-22	Orifice (Quantity 3)	20	Needle bearing (Quantity 3)
1-2-23	Orifice (Quantity 1)	21	Planetary gear B (Quantity 3)
1-2-24	Hexagon socket head bolt (Quantity 8)	22	Thrust plate (Quantity 3)
1-3	Shaft (Quantity 1)	23	Thrust plate (Quantity 1)
1-4	Cylinder block assembly (Quantity 1)	24	Screw (Quantity 3)
1-4-1	Cylinder block (Quantity 1)	25	Drive gear (Quantity 1)
1-4-2	Piston assembly (Quantity 9)	26 *	Thrust plate t = 3.6 mm (0.142 in) (Quantity 1)
1-4-3	Retainer plate (Quantity 1)	26 *	Thrust plate t = 2.3 mm (0.091 in) (Quantity 1)

Assembly of steel ball

Attach steel balls (1-6) to the spherical hole sections of the flange (1-1).

⚠ CAUTION:

Before attaching the steel balls, apply hydraulic oil to the inner diameter surface of the spherical holes of the flange.

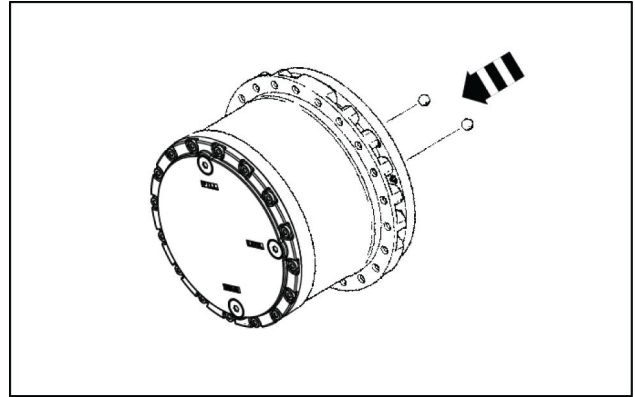

LPIL12CX01393AA 25

Assembly of shaft

Use the bearing press-fit jig to press fit the ball bearing (1-8) to the shaft (1-3).
Next, attach the shaft to the center of the flange (1-1).

⚠ CAUTION:

1. When attaching the ball bearing, attach it vertically.
2. After attaching the shaft, check that it rotates smoothly.

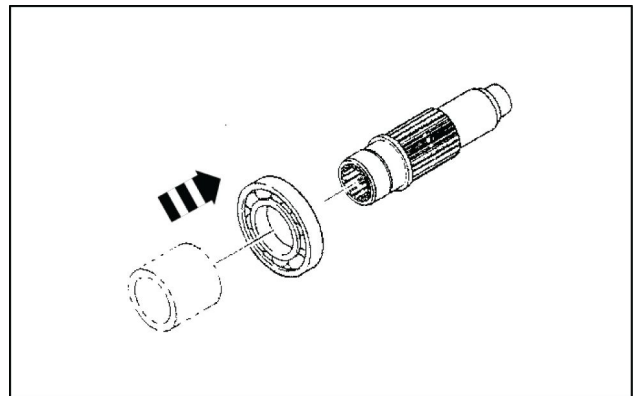

LPIL12CX01394AA 26

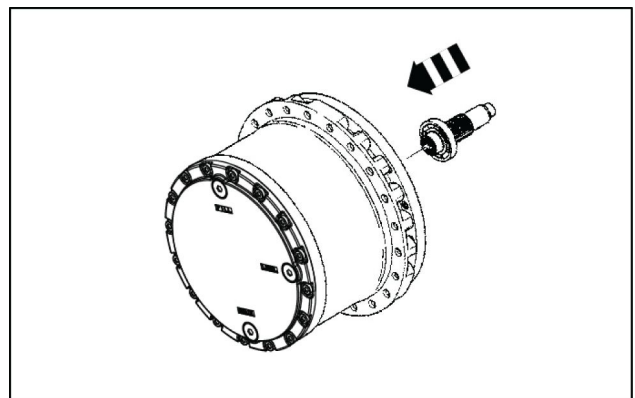

LPIL12CX01395AA 27

5. Use a wrench [**36 mm**] to remove the travel hoses (1) and a wrench [**27 mm**] to remove the drain hoses (2).
- Mark the center joint and hoses so that the connectors match at the time of assembly.
 - Attach caps or plugs to the center joint and hoses to prevent any entry of water, dust or dirt.
 - Clean the center joint and hoses by spraying them with a parts cleaner to prevent scratches and prevent dirt from accumulating on the connectors.

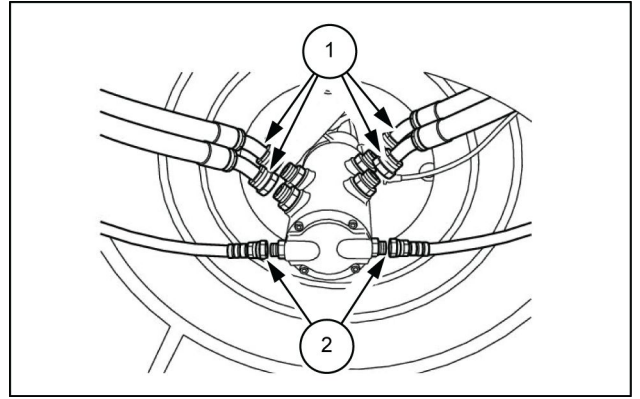

LPIL12CX01588AB 5

6. Use a wrench [**19 mm**] to remove the pilot hoses (1) and a wrench [**27 mm**] to remove the drain hose (2).
- Attach caps or plugs to the center joint and hoses to prevent any entry of water, dust or dirt.
 - Clean the center joint and hoses by spraying them with a parts cleaner to prevent scratches and prevent dirt from accumulating on the connectors.

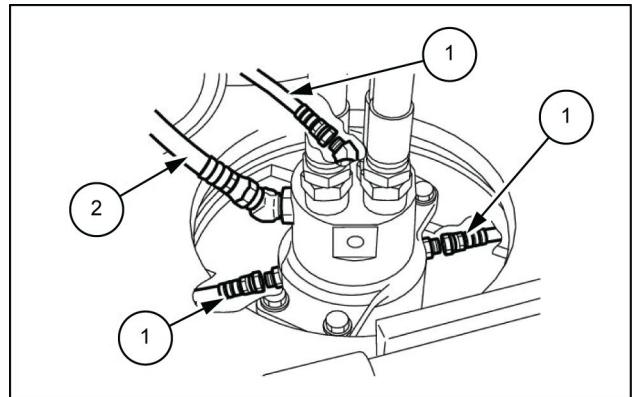

LPIL12CX01589AB 6

7. Use a wrench [**19 mm**] to remove the 2 bolts (2), and then remove the center joint lock bar (1).

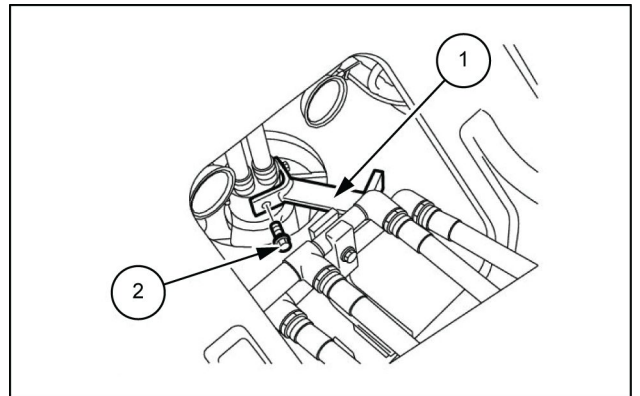

LPIL12CX01590AB 7

8. Use a wrench [**36 mm**] to remove the 4 travel hoses (1).
- Mark the hoses so that the connectors can be matched during assembly.
 - Attach caps or plugs to the hoses to prevent any entry of water, dust or dirt.
 - Clean the hoses by spraying them with a parts cleaner to prevent scratches and prevent dirt from accumulating on the connectors.

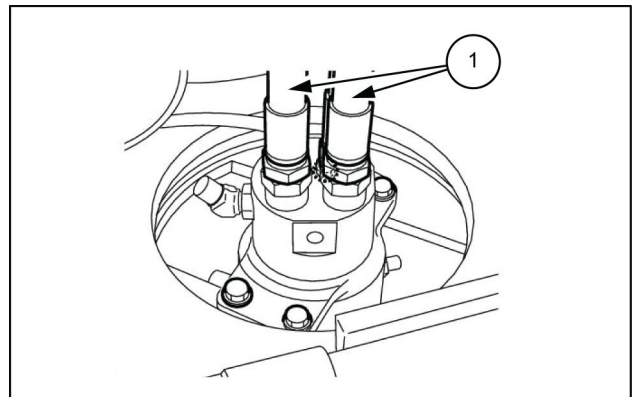

LPIL12CX01591AB 8

6. Buffer ring

12. Installation bolt

Bushing

The bushing is press fit to the inside surface of the cylinder head **(3)** and touches the piston rod **(2)**. Together with the slide rings **(18)** and **(19)** on the outer circumference of the piston, the bushing divides the lateral load applied to the cylinder and moves linearly relative to the piston rod. Furthermore, it supports one end of the piston rod and has the function of minimizing eccentricity which has a negative impact on the sealing.

Buffer ring

The buffer ring **(6)** has the function of buffering the pressure and heat applied on the U-ring **(7)** by the hydraulic oil to improve durability.

U-ring and backup ring

The U-ring **(7)** seals the pressure oil within the cylinder. The U-ring also has the function of forming an appropriate oil film on the surface of the piston rod in order to prevent rust of the piston rod **(2)**. The backup ring **(8)** has the function of suppressing extrusion of the U-ring into the gap between the piston rod and the cylinder head **(3)** when the pressure operates and of improving durability.

Wiper ring

The wiper ring **(9)** is positioned in the opening where the piston rod **(2)** comes out from and goes into the cylinder. This wiper ring **(9)** prevents dust and water from getting into the cylinder from the outside. It also has the function of wiping off any mud sticking to the surface of the piston rod as the piston rod moves.

Piston assembly

The piston assembly has the function of transmitting the propulsion of the cylinder. A seal ring **(16)** is mounted on the center of the piston **(15)** to prevent the flow of pressure oil from either the left or right chamber to the other chamber. There are slide rings **(18)** and **(19)** mounted at each end of the seal ring. They have the function of a bearing to receive the cylinder lateral load.

Dipper cylinder - Sectional view

CX250D Long Reach Crawler excavators LC Long Reach (TIER4 FINAL)
- NA Market

NA

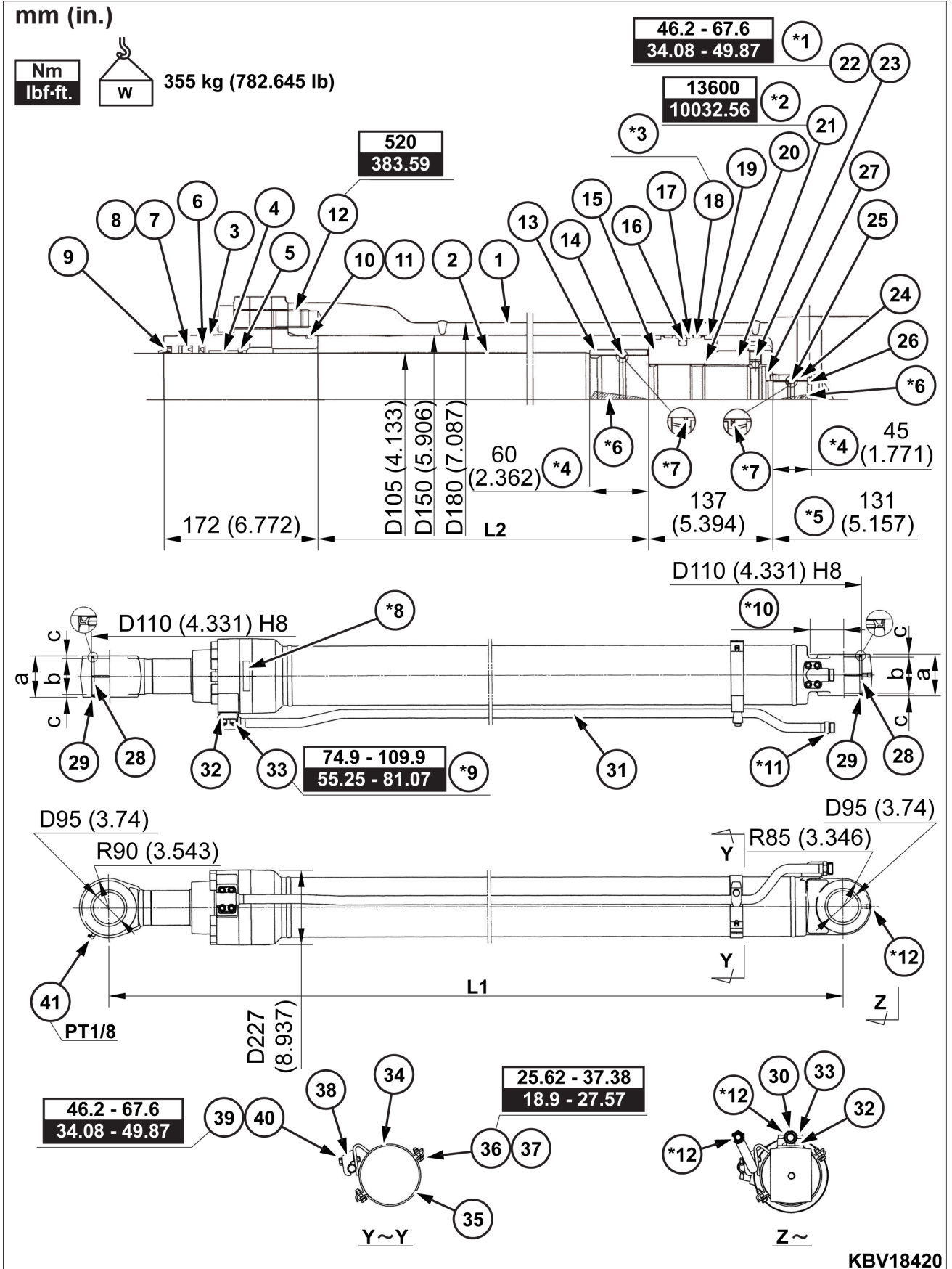

Counterweight - Remove

1. Remove the following before beginning work.
 - Engine hood, gas damper and lock stay.
 - Rear view camera and electrical parts bracket.
2. Remove the 2 rubber plugs (2) from the top of the counterweight (1).

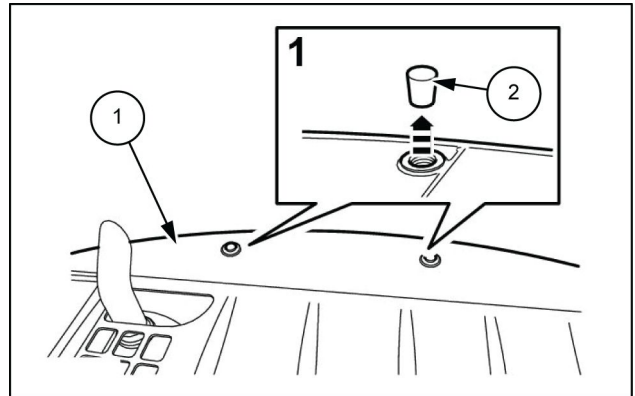

SMIL13CEX1067AB 1

3. Install the 2 eyebolts (M42) (1) in place of the removed caps.
 - Apply lubricating oil to the eyebolts.
 - Fully tighten the eyebolts, and then loosen them by a half turn.

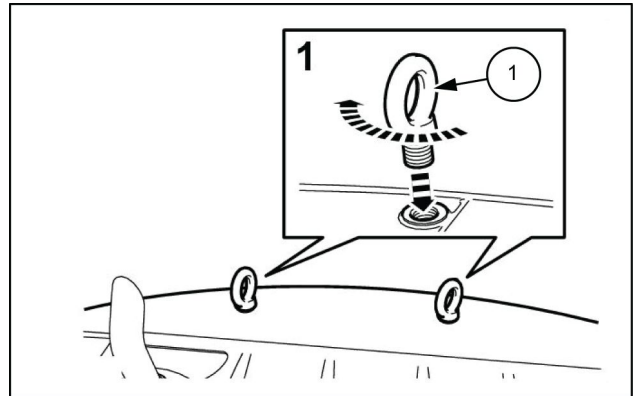

SMIL13CEX1068AB 2

4. Connect the eyebolts to the shackles (1), and then use the wire ropes (2) and liftcrane to secure the counterweight so that it does not fall during removal and installation operations.

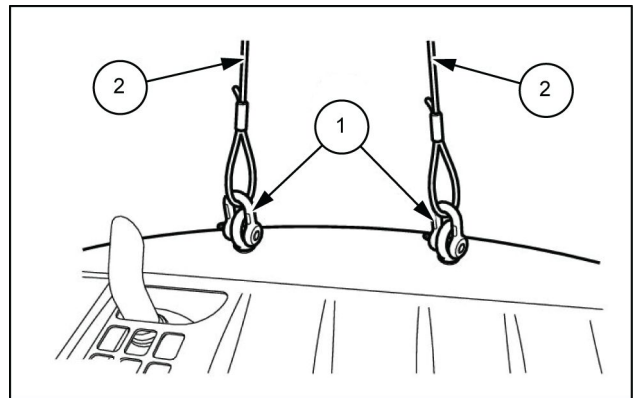

SMIL13CEX1069AB 3

5. Use a box wrench [50 mm] to remove the 4 bolts (1) and spacers (2) on the lower section of the counterweight.

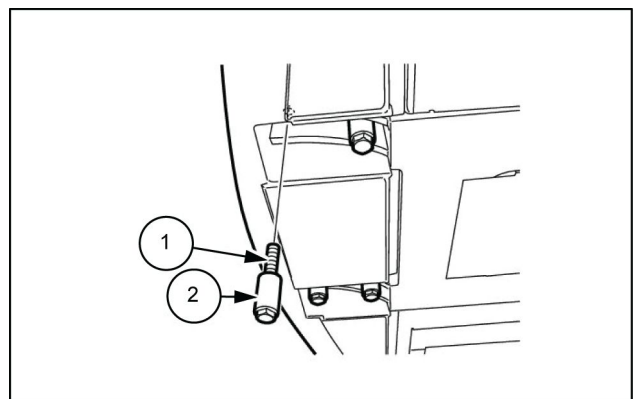

SMIL13CEX1070AB 4

Idler wheel - Dimension

Inspection gauge for take up roller

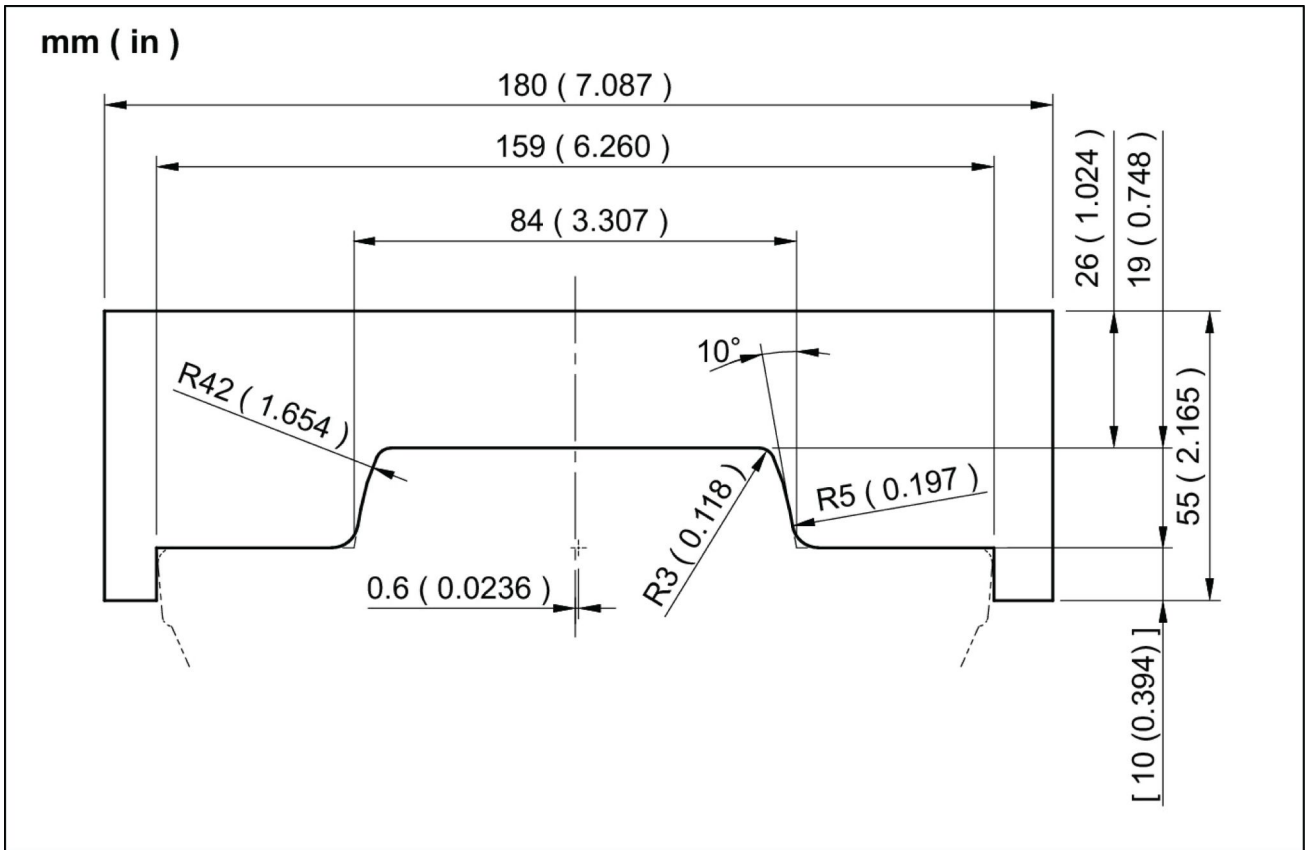

SMIL13CEX1309FA 1

NOTE: All the dimensions in figure are in mm (in).

CLICK HERE TO **DOWNLOAD** THE COMPLETE MANUAL

- Thank you very much for reading the preview of the manual.
- You can download the complete manual from: www.heydownloads.com by clicking the link below



- Please note: If there is no response to CLICKING the link, please download this PDF first and then click on it.

CLICK HERE TO **DOWNLOAD** THE COMPLETE MANUAL

Track support roller - Service limits

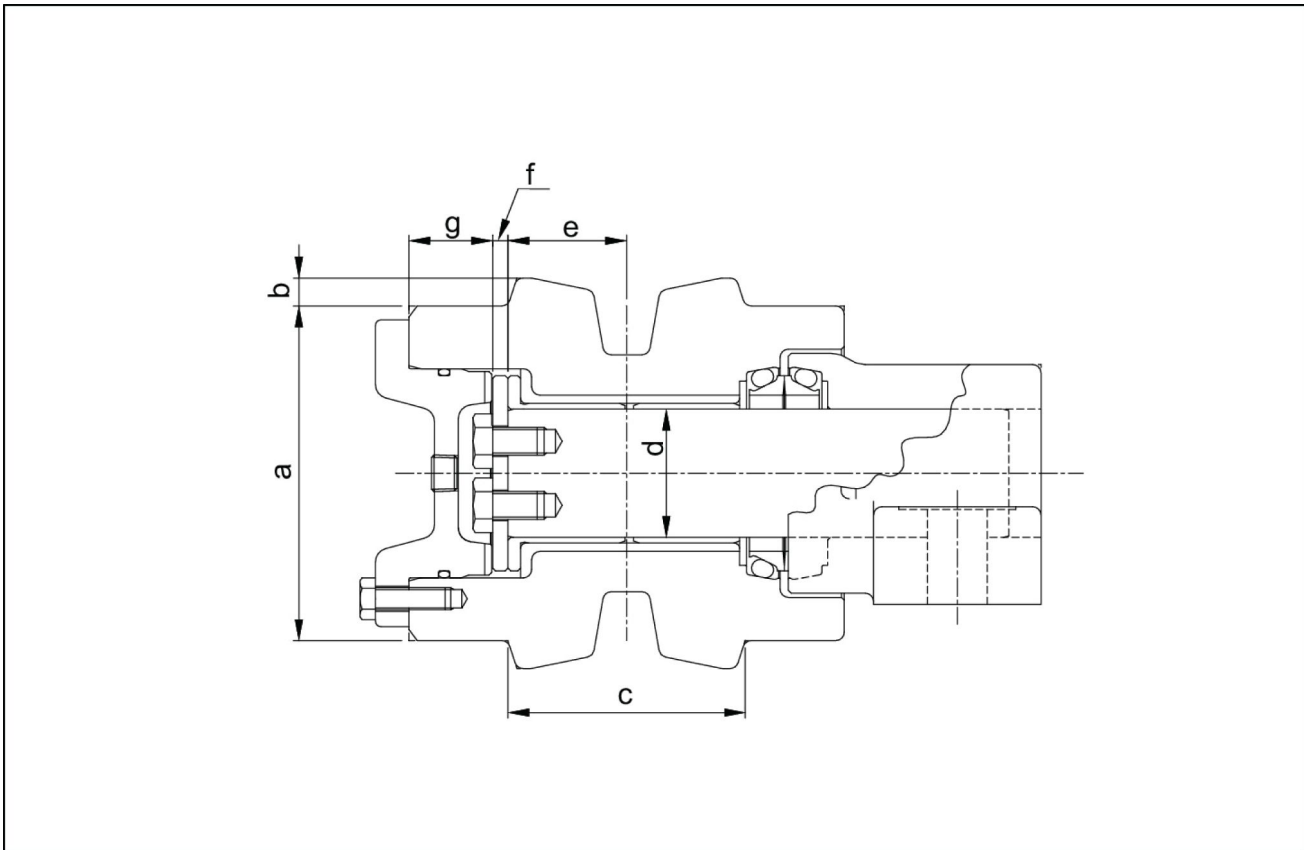

SMIL13CEX1913FA 1

NOTE: See the gauge list for measurement gauges (see *Track support roller - Dimension (48.138)*).

Part name	Code	Standard value	Usage limits	Judgment	Solution
Carrier roller	a	Ø 120 mm (4.724 in)	Ø 108 mm (4.252 in)	Acceptable/ Unacceptable	Cladding by welding or replacement
	b	10 mm (0.394 in)	-	Acceptable/ Unacceptable	
	c	85 mm (3.346 in)	79 mm (3.110 in)	Acceptable/ Unacceptable	
Shaft	d	Ø 46 mm (1.811 in)	Ø 45 mm (1.772 in)	Acceptable/ Unacceptable	Replacement
Bushing	d	Ø 46 mm (1.811 in)	Ø 46.8 mm (1.843 in)	Acceptable/ Unacceptable	Replacement
Bushing	e	42.5 mm (1.673 in)	42.1 mm (1.657 in)	Acceptable/ Unacceptable	Replacement
Thrust plate	f	5.5 mm (0.217 in)	4.5 mm (0.177 in)	Acceptable/ Unacceptable	Replacement
Cover	g	29.7 mm (1.169 in)	29.2 mm (1.150 in)	Acceptable/ Unacceptable	Replacement



SERVICE MANUAL

Cab climate control

CX250D Crawler excavators LC version (TIER4 FINAL) - NA Market
CX250D Long Reach Crawler excavators LC Long Reach (TIER4 FINAL)
- NA Market

Air-conditioning compressor - Install

1. To install, perform the reverse of the removal procedure.
When installing the bolts, tighten them to the specified torque.
2. Check the compressor oil quantity.
The compressor contains **135 cm³ (8.2 in³)** of oil.
The oil quantity being low will cause compressor seizing and a reduction in durability. The oil quantity being high will cause a reduction in cooling capabilities.
Make sure to check the oil quantity and adjust if needed.
Measure the oil quantity of the removed compressor. Only this oil quantity is necessary, so subtract this quantity from **135 cm³ (8.2 in³)** to determine the amount by which the oil quantity of the new compressor should be reduced.
Example
If the remaining oil quantity of the removed compressor is **30 cm³ (1.8 in³)**:
Remove **135 cm³ (8.2 in³) - 30 cm³ (1.8 in³) = 105 cm³ (6.4 in³)** from the new compressor to be installed.
Resupply oil: SP-10 or SP-20 (**CNH PAG OIL**)
3. Perform air conditioner gas charging.
For details, refer to **Air conditioning - Filling (50.200)**.

Flow control proportional valve

(P1) (P2)

Part No.: KBJ18651

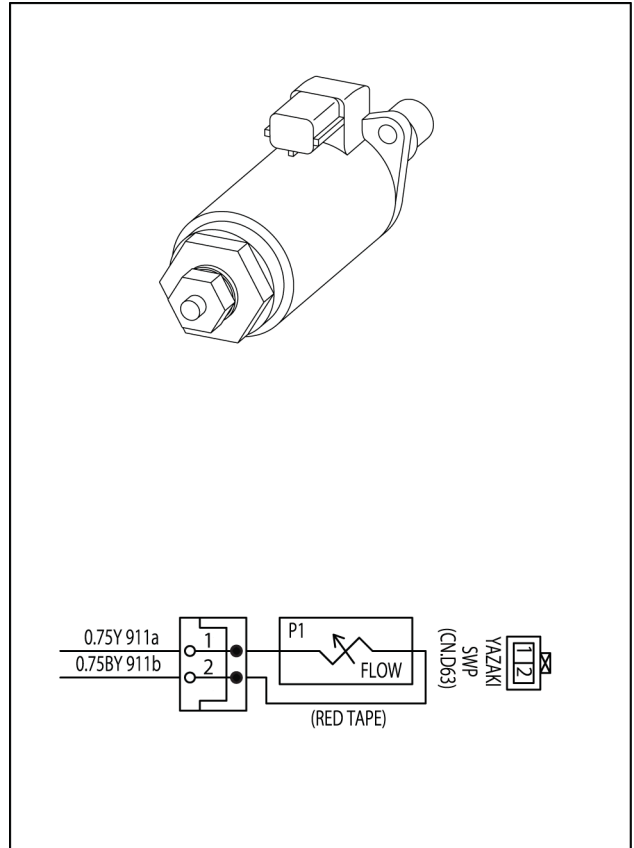

SMIL14CEX4138BA 33

Standard seat

Part No.: KHN39520

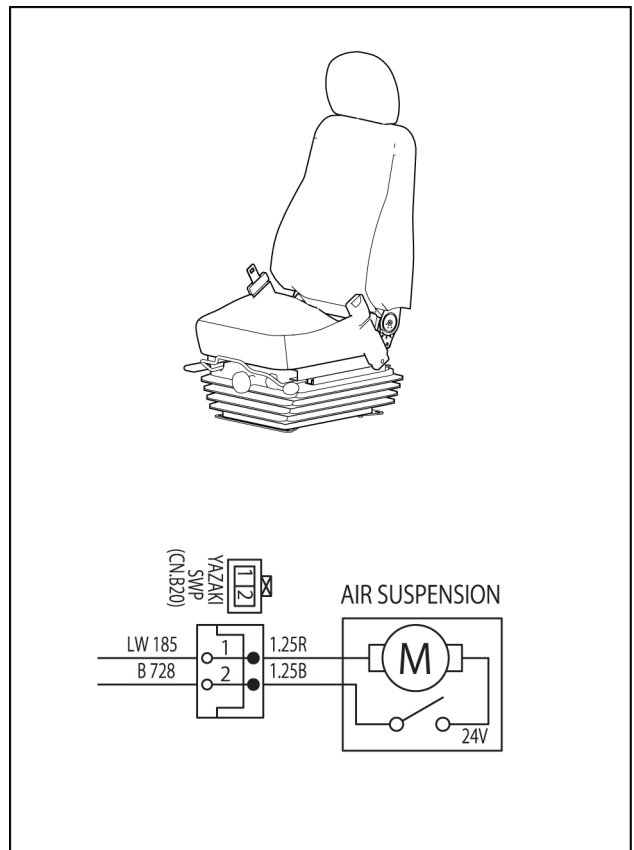

SMIL14CEX4139BA 34

Main unit right side layout diagram (pump chamber)

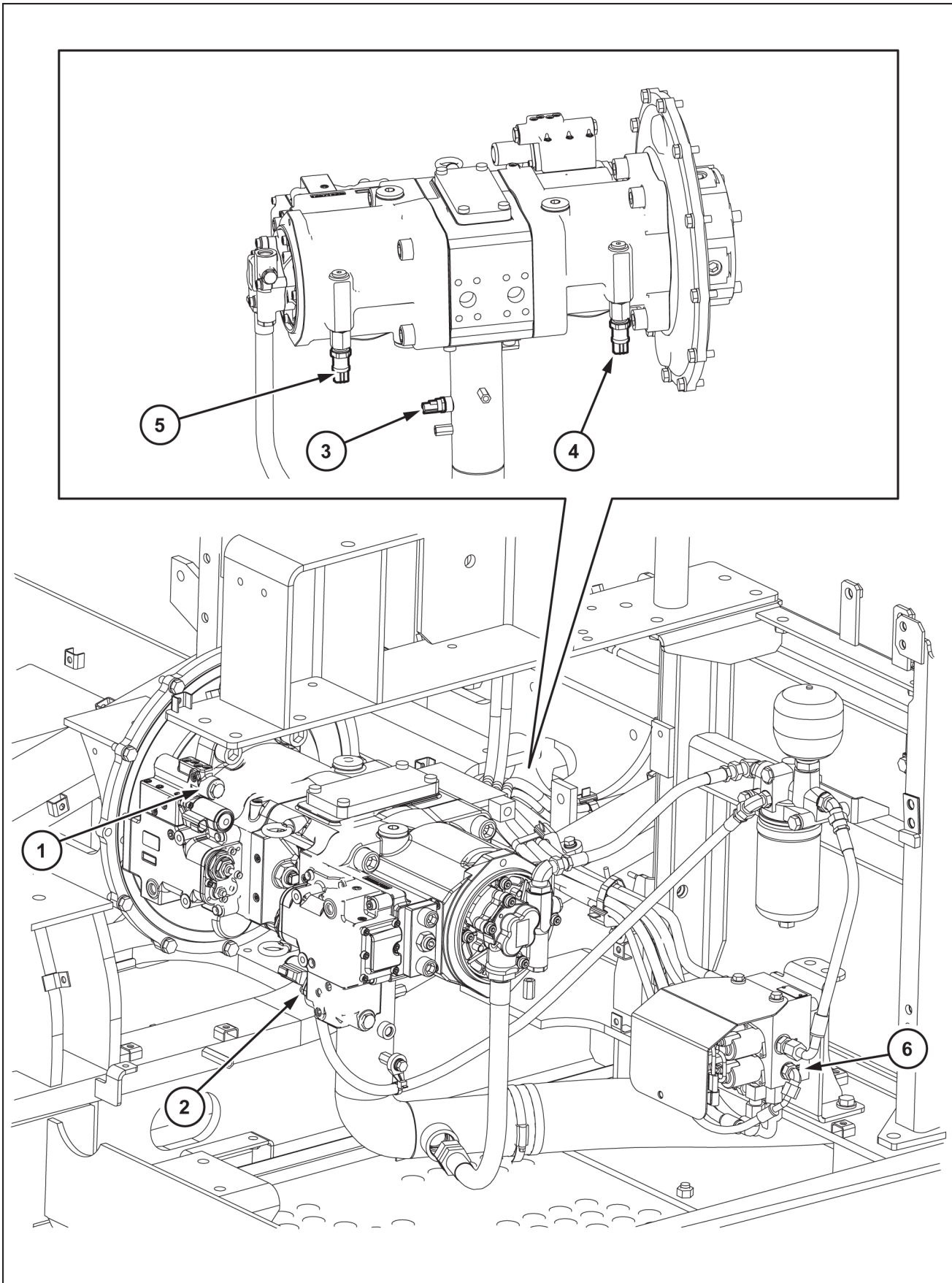

SMIL15CEX0610HB 5

SCR harness

NOTE: Install the rear covers on connectors CN.D90-5M and D90-6M.

- a. CN.D90-2M must be fastened with red tape.

*1. White adhesive tape

*2 Plate

CN.D90M	Frame main harness	CN.D90-4F	SCR upstream temperature sensor
CN.D90-1F	SCR inlet NOx sensor	CN.D90-5M	Exhaust gas temperature sensor (CFS-IN)
CN.D90-2M	CN J1939	CN.D90-6M	Exhaust gas temperature sensor (DOC-IN)
CN.D90-3F	Dosing valve		

Electrical systems - Harnesses and connectors

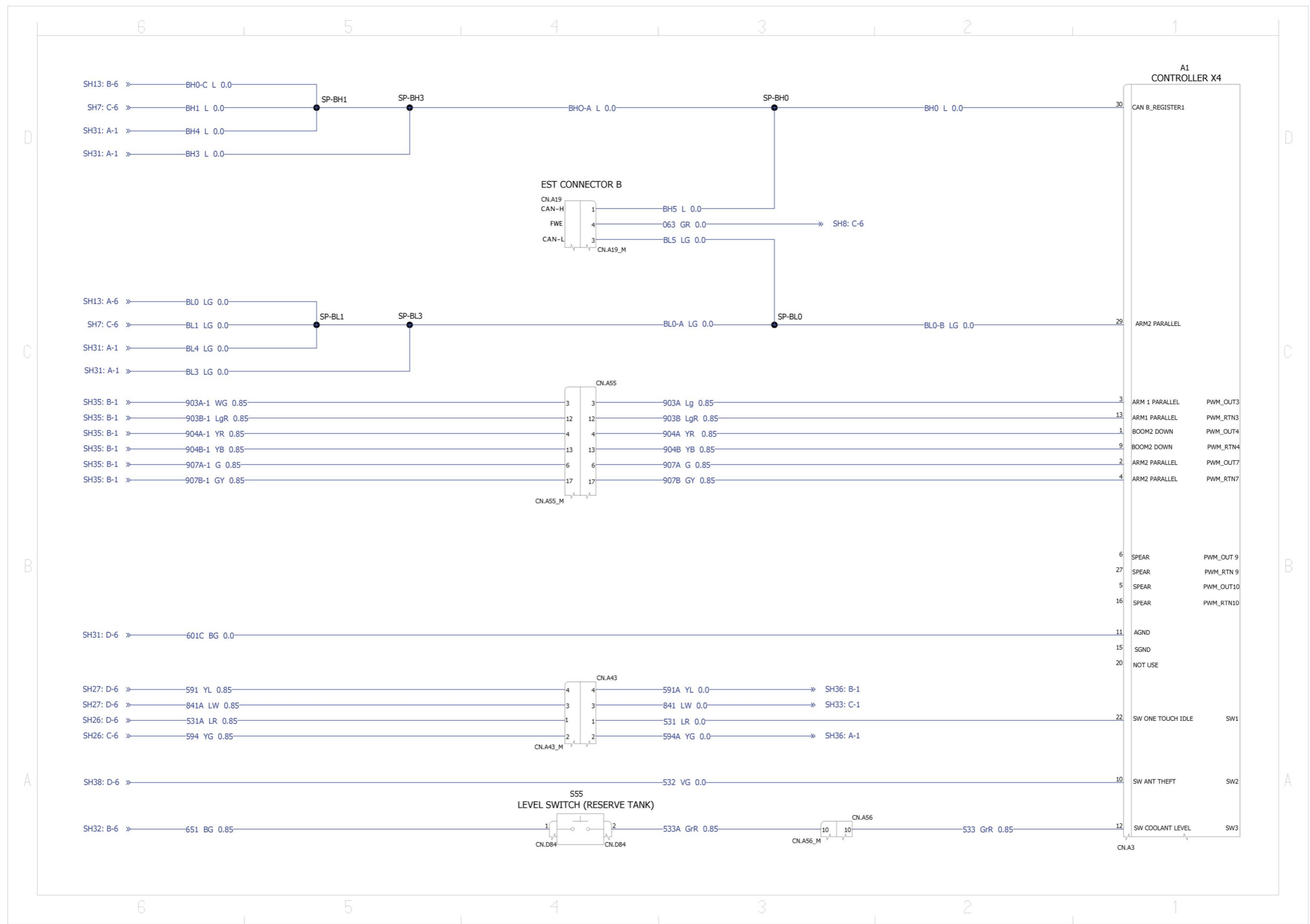

Harnesses and connectors - Electrical schematic sheet 26 - Knob-left

Type	Component	Connector / Link	Description
Switch	P22		Knob-left (4 switch)
Lever	P25		Knob proportional lever left
Lever	P26		Knob proportional lever right
Switch	S15		Horn
Switch	S69		Mute
Switch	S104		Proportional lever
Switch	S105		Switch proportional solenoid 2
Connector	CN.B7		Knob-left (4 switch)
Connector	CN.B8		Knob proportional lever left

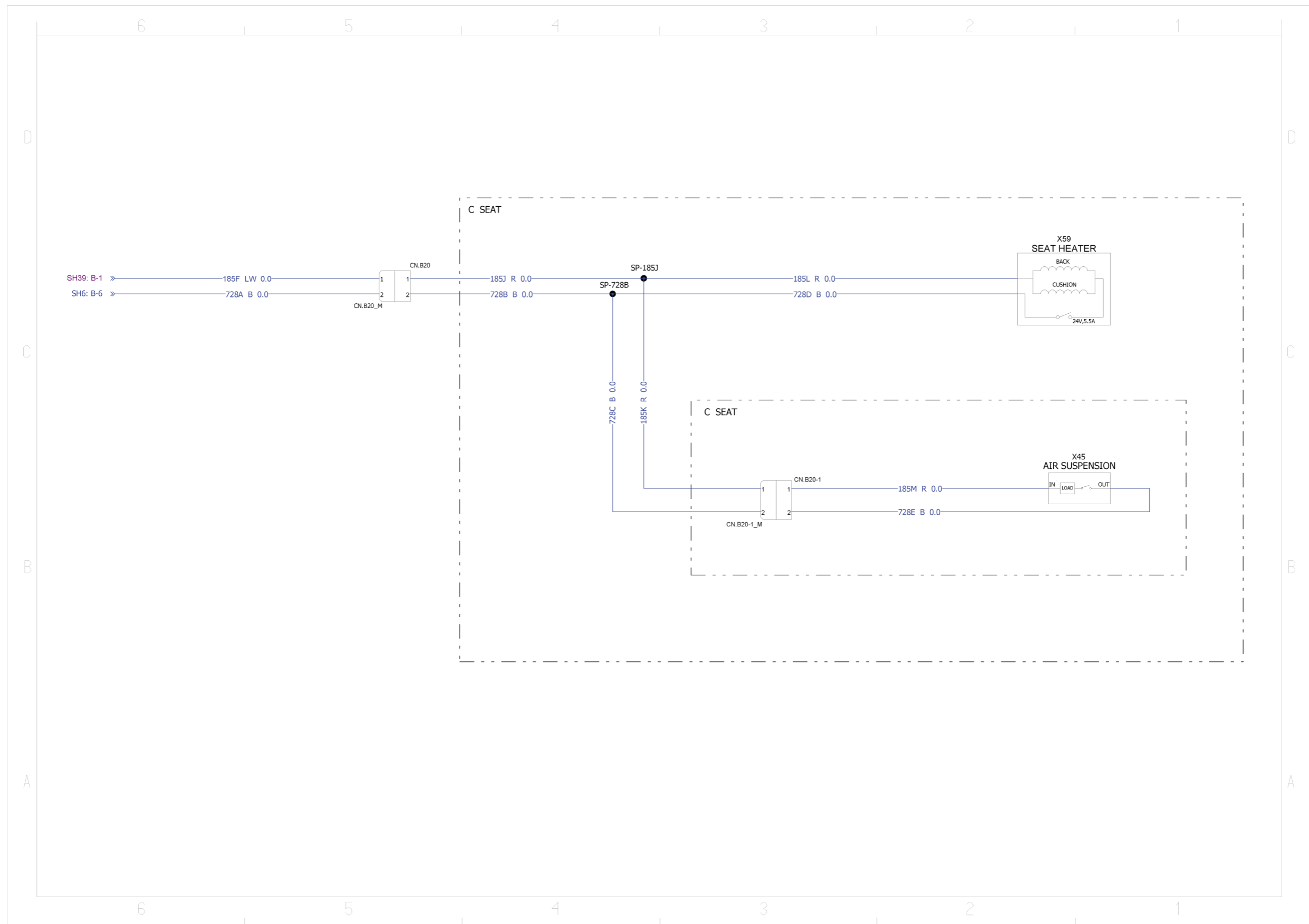

SMIL15CEX1623JA 1

Electrical systems - Harnesses and connectors

Pin	From	Wire	Description	Color-Size	Frame
E49	SP-318A-P-X	318		G-0.75	SHEET 14
E50	SP-327O-P-X	327		G-0.75	
E54	CN.D6-P-2	354		W-0.75	
E55	CN.D6-P-3	355		GR-0.75	
E59	SP-356-P-X	356		RG-0.75	
E61	SP-352A-P-X	352C		Y-0.75	
E63	SP-396A-P-X	396		RW-0.75	
E68	SP-325A-P-X	325		RW-0.75	SHEET 13
E69	SP-316A-P-X	316		R-0.75	SHEET 14
E71	SP-692A-P-X	692A		BL-0.85	SHEET 13
E73	SP-691A-P-X	691A		BW-0.85	
E74	SP-690A-P-X	690A		B-0.85	
E78	CN.D5 M-P-6	311		R-0.75	
E84	SP-394A-P-X	394A		RG-0.75	
E89	CN.D7-P-13	393		GR-0.75	
E90	CN.D7-P-12	392		B-0.75	
E91	CN.D6-P-7	388		WL-0.75	SHEET 14
E92	CN.D6-P-6	387		WB-0.75	
E93	CN.D6-P-5	386		WR-0.75	
E99	CN.D8-P-18	317A		L-0.75	
E105	SP-394A-P-X	394		RG-0.75	

CONNECTOR CN.G8: Option 1 (left) solenoid valve (Male)

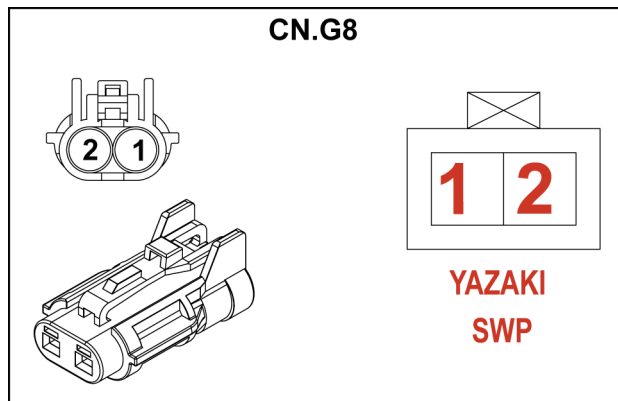

SMIL15CEX1092AA 87

Pin	From	Wire	Description	Color-Size	Frame
1	SP-351-P-X	230I		W-0.85	SHEET 23
2	SP-852A-P-X	852		OR-0.85	

CONNECTOR CN.D11: Alternator (Female)

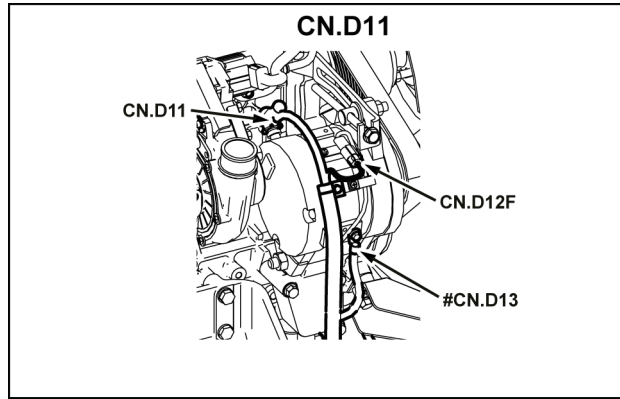

SMIL15CEX1451AA 48

Pin	From	Wire	Description	Color-Size	Frame
1	CN.D15-P-1	30		R-20.0	SHEET 01

CONNECTOR CN.A28: Lamp (cab) (Female)

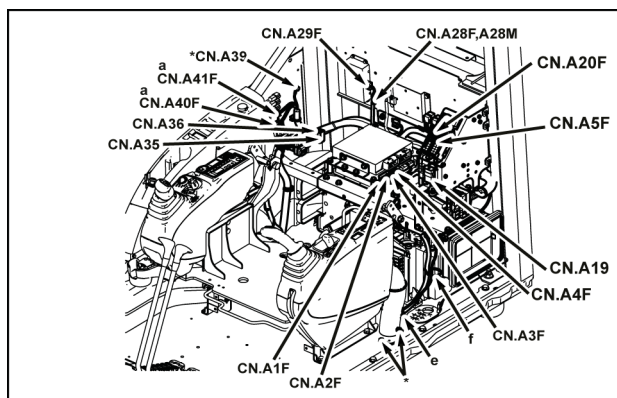

SML15CEX1567AA 11

Pin	From	Wire	Description	Color-Size	Frame
2	SP-876-P-X	875D		GR-1.25	SHEET 37

CONNECTOR CN.D206: Battery cut switch (Female)

Pin	From	Wire	Description	Color-Size	Frame
M10	P68-P-M8	799A		B-60.0	SHEET 01

CONNECTOR CN.D37: PN diode (Female)

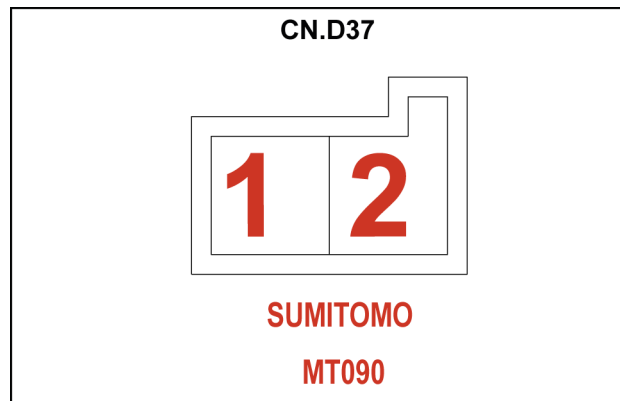

SMIL15CEX1951AA 33

Pin	From	Wire	Description	Color-Size	Frame
1	SP-250A-P-X	250A		YG-0.75	SHEET 22
2	SP-752A-P-X	752A		Br-0.75	

CONNECTOR CN.A54 (Male)

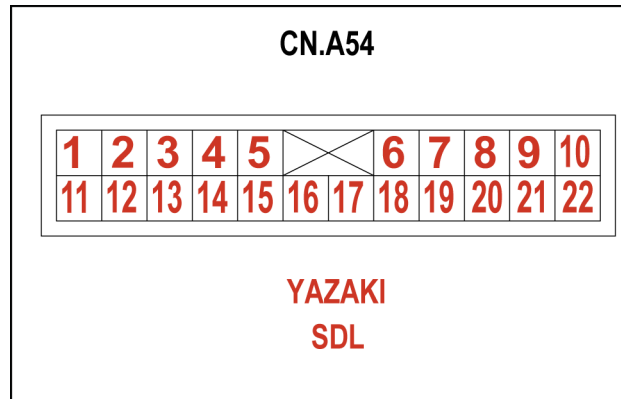

SMIL15CEX1048AA 21

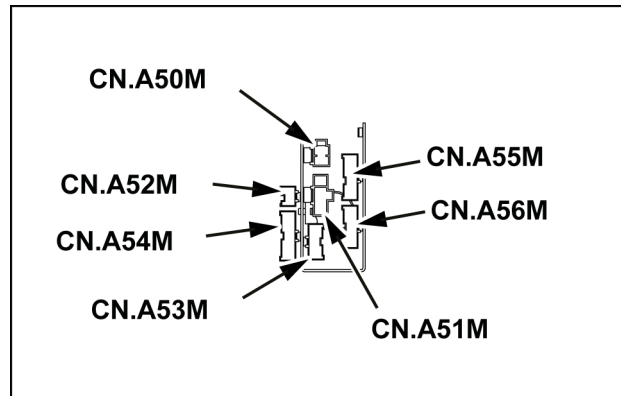

SMIL15CEX1047AA 22

Pin	From	Wire	Description	Color-Size	Frame
1	SP-435-P-X	435C		WL-0.85	
2	SP-445E-P-X	445C		BW-0.85	
3	CN.D83_M-P-2	401A		YG-0.85	
4	CN.D81-P-7	402A		BrW-0.85	
5	CN.D81-P-8	403A		BrR-0.85	
6	CN.D69-P-2	404A		LgR-0.85	
7	CN.D70-P-2	405A		LR-0.85	
8	CN.D71-P-2	406A		LW-0.85	
9	CN.D72-P-2	407A		YR-0.85	
10	CN.D73-P-2	408A		YG-0.85	
11	CN.D74-P-2	409A		GR-0.85	
12	CN.D75-A-P-2	410A		GW-0.85	
13	CN.D82_M-P-2	411A		OR-0.85	
14	CN.D82_M-P-3	412A		OL-0.85	
15	CN.D82_M-P-4	413A		OW-0.85	
16	CN.D76_M-P-2	414A		LgR-0.85	
17	CN.D83_M-P-3	415A		WL-0.85	
18	CN.D77_M-P-2	421A		Gr-0.85	
19	CN.D78-P-2	425A		Y-0.75	
20	CN.D80-P-2	426A		GL-0.85	
21	CN.D80-P-1	660		BG-0.85	
22	-				

CONNECTOR CN.D66-3: Arm2 parallel proportional solenoid valve (Female)

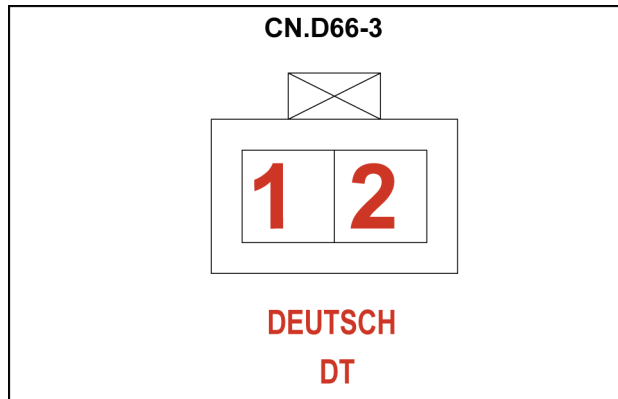

SMIL15CEX1970AA 22

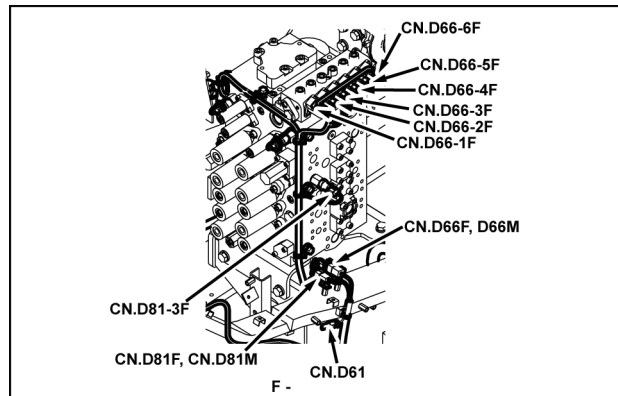

SMIL15CEX1969AA 23

Pin	From	Wire	Description	Color-Size	Frame
1	CN.D66_M-P-5	907A-2		G-0.85	SHEET 34
2	CN.D66_M-P-6	907B-2		GY-0.85	

CONNECTOR CN.D90-1: NOx sensor (SCR IN) (Female)

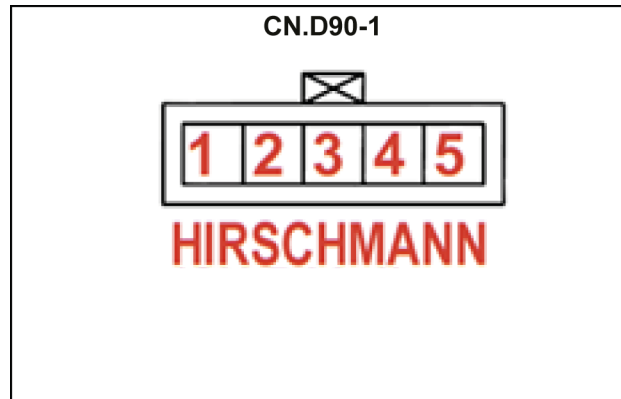

SMIL15CEX1538AA 6

Pin	From	Wire	Description	Color-Size	Frame
1	CN.D90 M-P-2	501R		G-0.75	SHEET 22
2	SP-789A-P-X	789		B-0.75	
3	SP-DL2-P-X	DL2		WG-0.75	
4	SP-DH2-P-X	DH2		W-0.75	
5	SP-789A-P-X	789A		B-0.75	

Target engine speed

The target engine speed is calculated from the degree of opening (position) of the throttle volume.

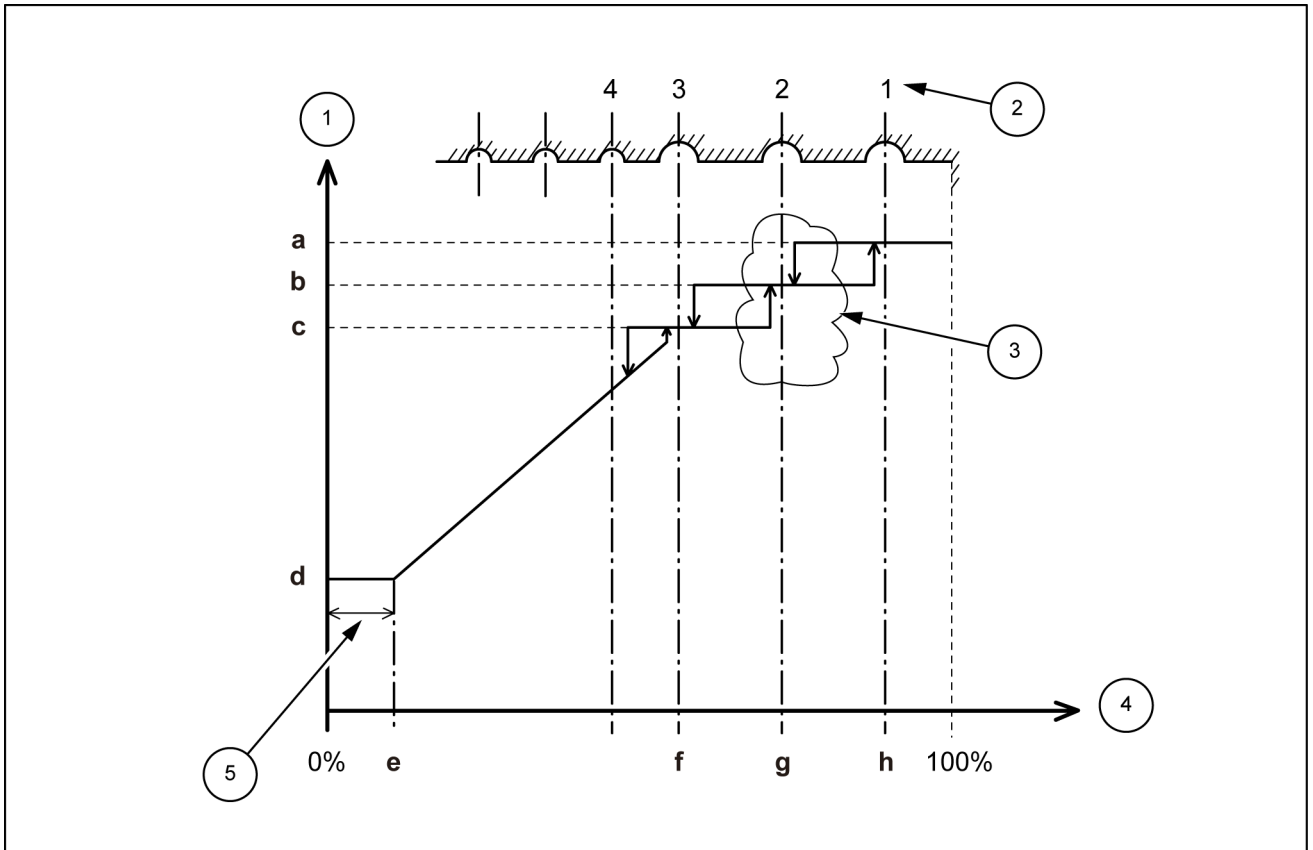

SMIL14CEX1029FB 3

- | | | |
|--|---------------|-------------------------------|
| 1. Engine speed [min-1] | Detent number | c. rpm-A |
| 2. Detent number | | d. rpm-Lo |
| 3. Hysteresis | | e. Position Lo (fixed at 10%) |
| 4. Throttle volume position [%] (position) | | f. Position A |
| 5. h play | | g. Position H |
| a. rpm-SP | | h. Position SP |
| b. rpm-H | | |

Control

Calculation of target speed:

1. Required throttle speed

Detent number	Degree of opening of volume	Required throttle speed (engine speed)	Variable name in Fig.
1		SP mode speed	rpm-SP
2		H mode speed	rpm-H
3		A mode speed	rpm-A
4 or above	10% or more	Calculated from degree of opening of volume (e-f in Fig.) and linear expression in Fig.	
4 or above	Less than 10%	Low idle speed	rpm-Lo

2. Target engine speed

- o Offset of speed:

Although the offset speed is usually zero, it dynamically varies with AES, BES, etc. Therefore, the output speed (target engine speed) should be obtained by subtracting the offset speed from the throttle speed.

Overheat switch

The overheat switch is installed to the water outlet pipe and turns ON if the engine coolant temperature exceeds **105 °C (221 °F)**.

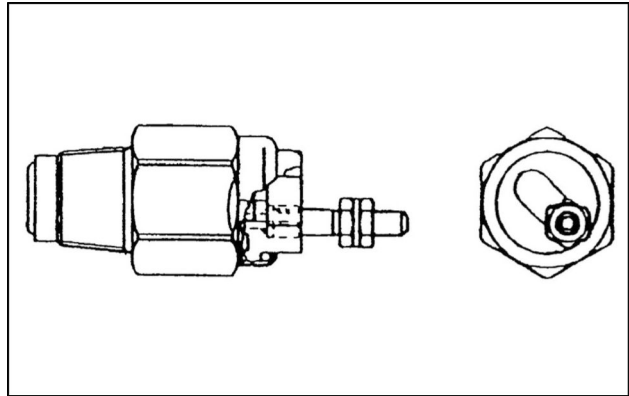

SMIL14CEX4001AA 10

CKP sensor

The CKP sensor is installed on the flywheel housing and generates a CKP signal when the protruding section on the flywheel passes by the sensor. The ECM determines the cylinder and specifies the crank angle using the CKP signal input from the CKP sensor, and uses the information for the fuel injection control and the calculation of the engine speed. While these controls are usually performed using the CKP signal, the CMP signal is used instead when the CKP sensor is faulty.

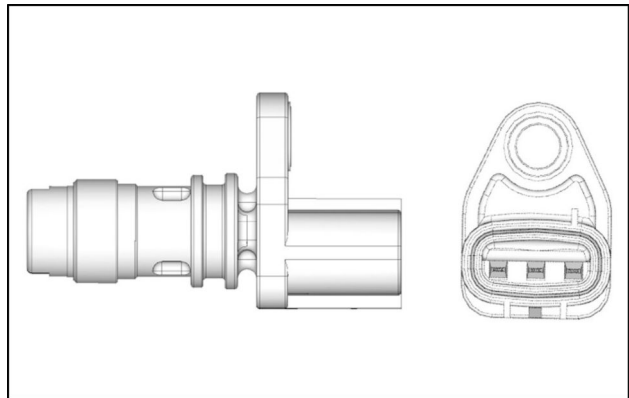

SMIL14CEX4002AA 11

CMP sensor

The CMP sensor is installed on the rear part of the cylinder head and generates a CMP signal when the cam section of the camshaft passes by the sensor. The ECM determines the cylinder and specifies the crank angle using the CMP signal input from the CMP sensor, and uses the information for the fuel injection control and the calculation of the engine speed. While these controls are usually performed using the CKP signal, the CMP signal is used instead when the CKP sensor is faulty.

1. Camshaft gear
2. Rotational direction
3. CMP sensor

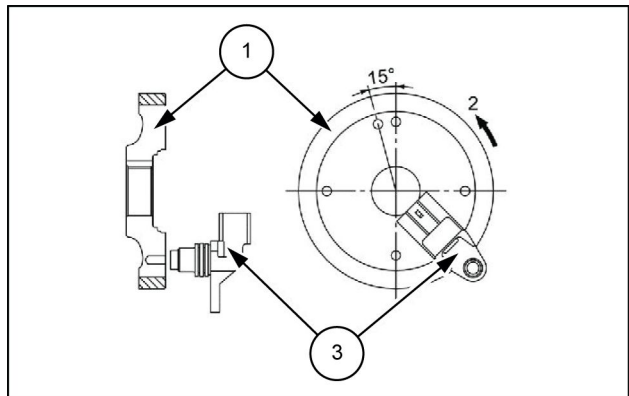

SMIL13CEX1753AB 12

Engine starting system - Dynamic description - Neutral start

Purpose

When the gate lock lever is in the unlocked (operation) state, the engine does not start. (No cranking)

It prevents incorrect operation even if you touch the operation lever when starting the engine.

Configuration

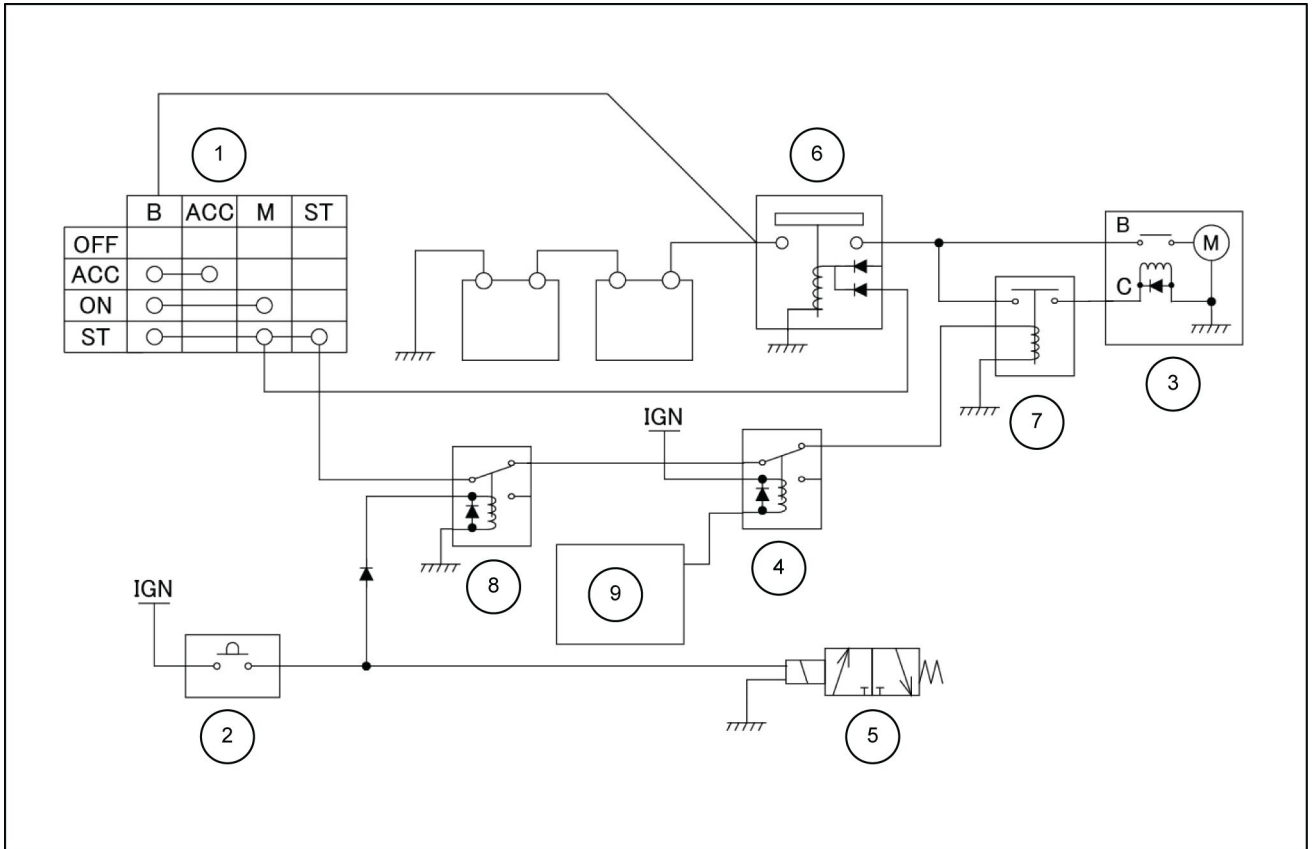

LPIL12CX00388FB 1

- | | |
|---------------------------|------------------|
| 1. Key switch | 6. Battery relay |
| 2. Gate lock limit switch | 7. Starter relay |
| 3. Starter motor | 8. Safety relay |
| 4. Starter cut relay | 9. ECM |
| 5. Gate lock solenoid | |

Operation explanation

1. Put the gate lock lever into the unlocked (operation) state.
2. The starter cut relay will be energized and the energization of the safety relay will be interrupted.
3. Engine cranking will be prohibited.
4. When the gate lock lever is put into the locked (non-operation) state, cranking will be permitted.

16. Inspect the suction air system.
17. Inspect the exhaust pipes for crushing, breakage, and exhaust leaks.
18. Repair or replace any parts in which problems are found.

Start circuit system inspection

Start circuit system inspection - Functions

The starter relay on the ECM is turned to ON when the ignition switch moves to the START position. When the starter relay is turned to ON, the starter operates to start the engine.

Start circuit system inspection - Inspection

Inspection performed when the starter does not operate.

1. Turn the emergency stop switch to OFF.
2. Check the DTC.

NOTE: If a DTC is set, inspect the applicable DTC.

3. Turn OFF the ignition switch.
4. Remove the starter cut relay.
5. Inspect the starter cut relay.
 - Check the continuity between the switch side terminals.

Standard value: **100 Ω** or less

6. If a problem is found, replace the relay.
7. Remove the starter relay.
8. Inspect the starter relay.
 - Connect the battery between the coil side terminals and check the continuity between the switch side terminals.

Standard value: **100 Ω** or less

9. If a problem is found, replace the relay.
10. Inspect the ignition switch start signal circuit.
 - No open circuits or high resistance should be found between the ignition switch and ECM.

Standard value: **100 Ω** or less

- No short circuits with the GND should be found between the ignition switch and ECM.

Standard value: **10 Ω** or more

11. If a problem is found, repair the circuit.

Battery connect and disconnect system - Static description

Purpose

A switch to enable safe and easy cut off of the electrical circuit for maintenance involving electrical system repair or welding repair of the main unit.

Location of mounting: Vicinity of battery

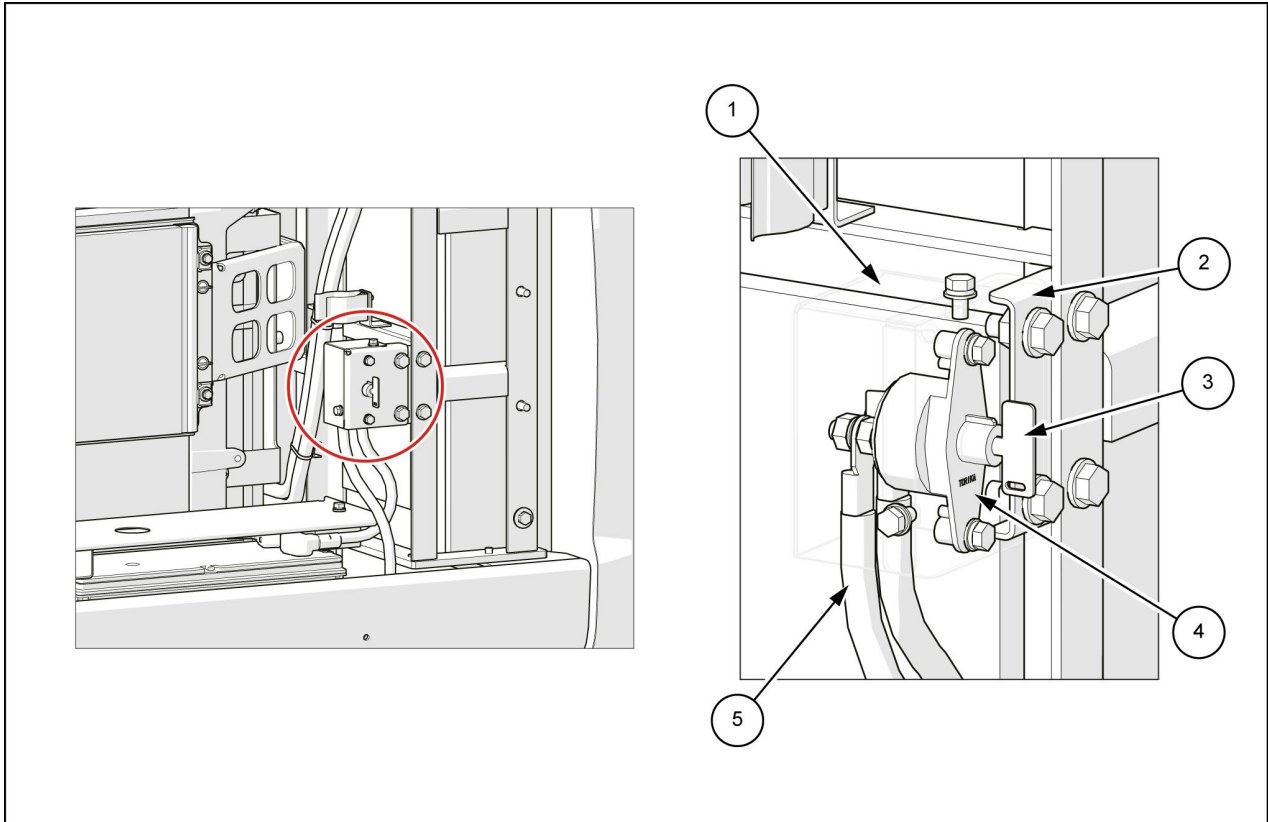

SMIL14CEX0912FB 1

- | | |
|-------------------|---------------------------------|
| 1. Cover | 4. Label battery cut-off switch |
| 2. Bracket | 5. Battery switch cable |
| 3. Battery switch | |

By-effect of turning OFF the battery cut-off switch

Setting of clock/radio	Reset
Model setting of controller	Log is maintained
Monitor information	Log is maintained
Error code	(Battery OFF within 30 s after key OFF) Not recorded
G navigation position information	(Battery ON within 60 s after key ON) No acquisition

Operation

1. The controller makes clogging judgment of the air filter based on signal (ON/OFF) of the air filter clogging switch and then sends the result to ECM and the monitor via CAN communication.
2. ECM restrains fuel injection quantity upon receiving the signal from the controller.
3. The monitor receives the signal from the controller to display a message and sounds alarm.

Operation condition

1. Start control at **10 s** after starting up the engine (wait for stabilized suction air).
2. It judges as a clogging of the air filter when the air filter clogging switch is ON to execute the following actions.
 - Message "AIR FILTER" is displayed on the monitor.
 - Alarm sounds for **5 s**.
 - Fuel injection quantity is restrained.
 - The diagnostic trouble code is recorded in the trouble log.
 - Continuing work by operator ignoring the warning may result in exemption from system warranty. The engine will not be forced to stop.

Stop condition

1. When the air filter clogging switch continues to be OFF for **3 s** or more, the system executes the following actions.
 - Message of the monitor is hidden.
 - Normal operation resumes from restraint of fuel injection quantity.

71	–
72	–
73	–
74	–
75	–
76	–
77	–
78	–
79	Urea fluid tank temperature sensor signal
80	–
81	–
82	–
83	–
84	–
85	Coolant control valve GND
86	Reverting valve power supply

B connector (53 pin)

Pin no	Connector
1	DCU GND
2	DCU GND
3	DCU GND
4	DCU GND
5	DCU GND
6	DCU power supply
7	DCU power supply
8	DCU power supply
9	DCU power supply
10	–
11	CAN1 High
12	CAN1 Low
13	–
14	CAN0 High
15	CAN0 Low
16	–
17	–
18	–
19	–
20	–
21	–
22	–
23	–
24	–
25	–
26	–
27	–
28	–
29	–
30	–
31	–
32	–
33	–
34	–
35	–
36	–
37	–

Diesel Exhaust Fluid (DEF)/AdBlue® supply module - Remove - Urea pump

1. Remove the 6 bolts (1) with a wrench [19 mm] to remove the cover (2).

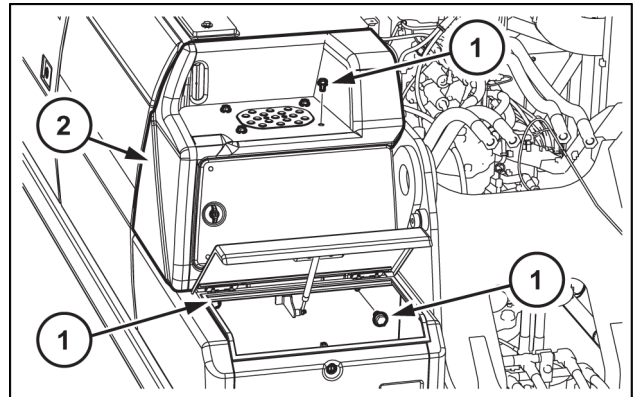

SMIL15CEX0640AB 1

2. Remove the 4 bolts (1) with a wrench [19 mm] to remove the step (2).

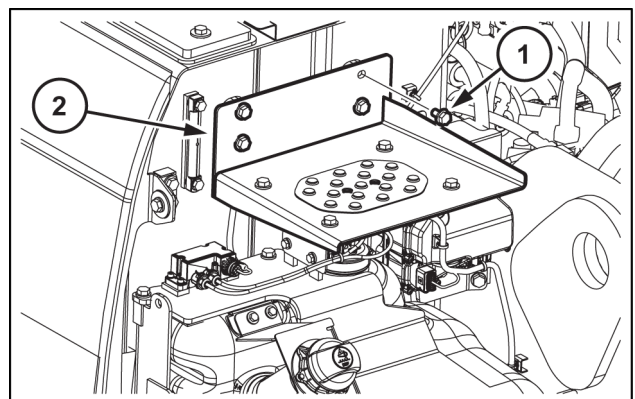

SMIL15CEX0641AB 2

3. Remove the 3 bolts (1) with a wrench [13 mm] to remove the cover (2).

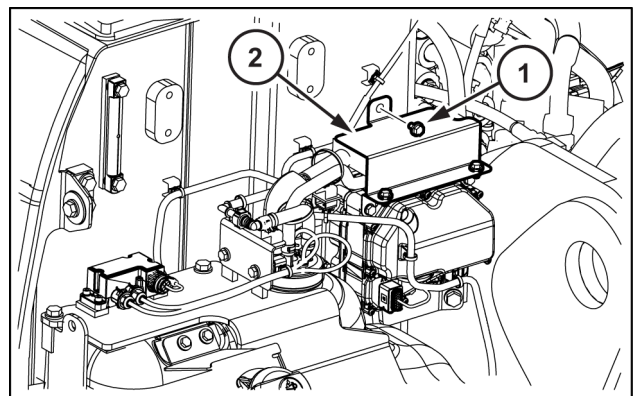

SMIL15CEX0642AB 3

- When **3 min** or more elapses without operation of upper, travel, swing, option 1, or option 2 in the state that engine speed is **1250 RPM** or less.

Instrument cluster - Electrical schema

Monitor

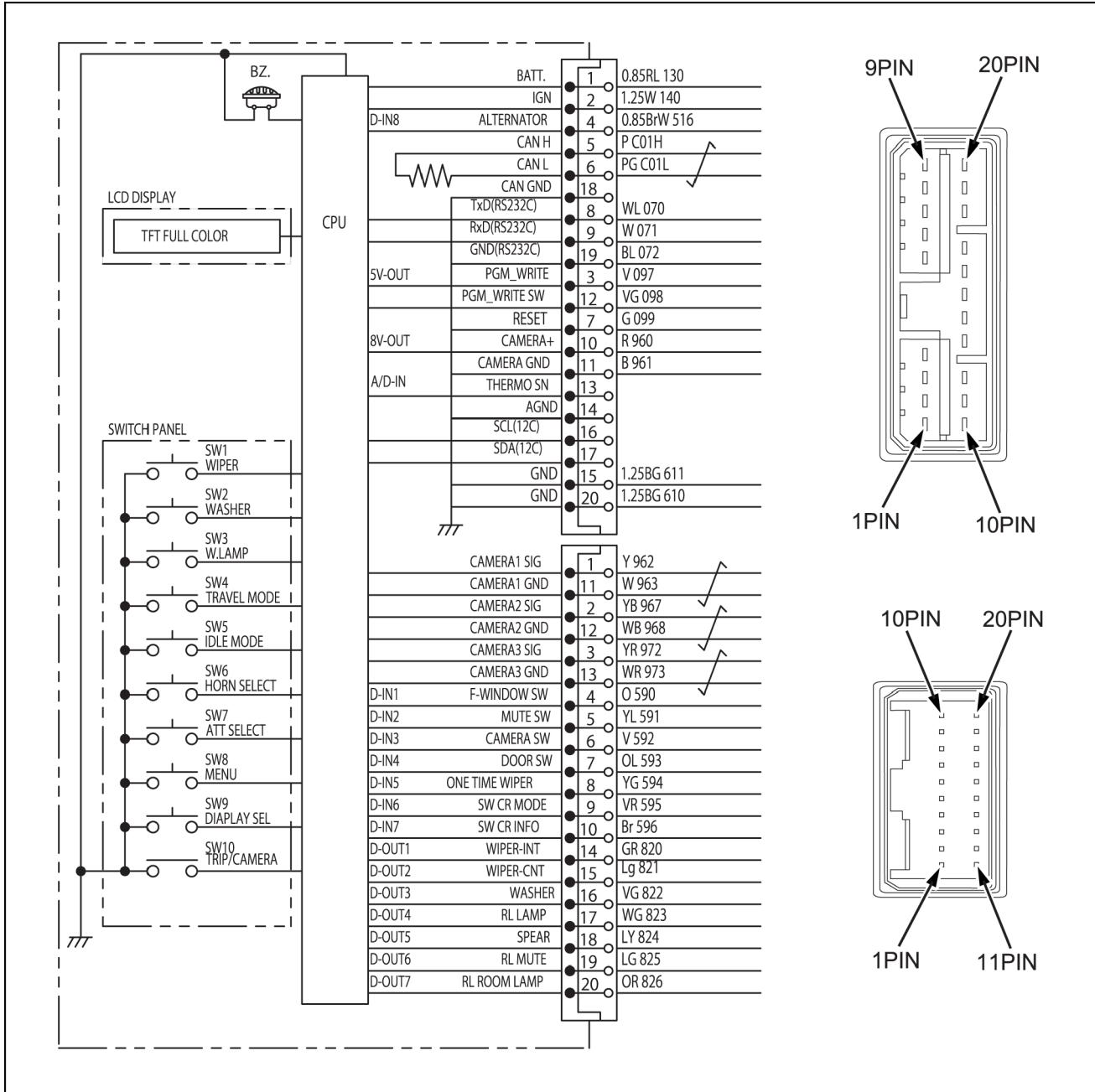

SMIL14CEX1218GA 1

3/11

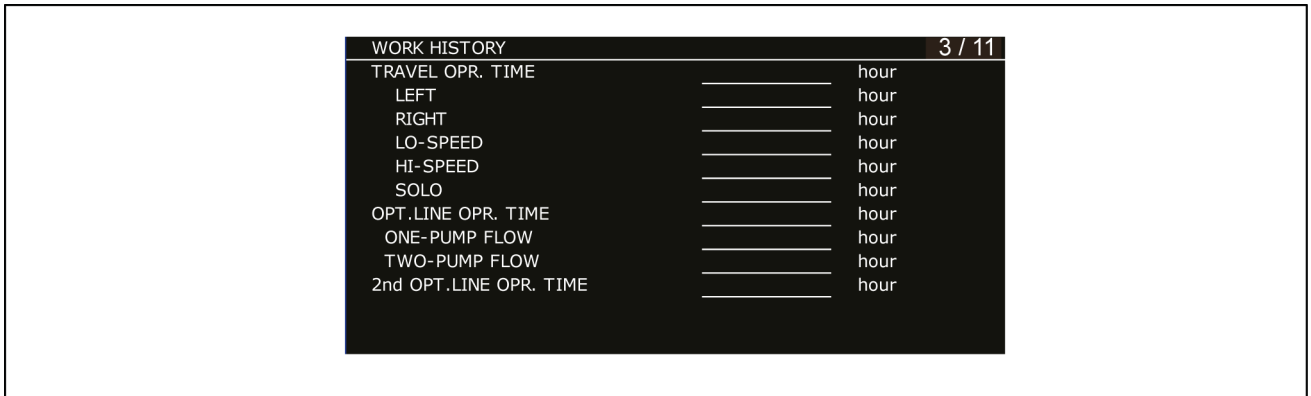

SMIL14CEX0945EA 32

Display	Explanation	Unit	Judgment condition	Judgment start condition
TRAVEL OPR. TIME	Travel operation time (both right and left)	hour	Travel operation judgment = ON	Engine in operation
LEFT	Left travel operation time	hour	Left travel operation judgment = ON	Engine in operation
RIGHT	Right travel operation time	hour	Right travel operation judgment = ON	Engine in operation
LO-SPEED	1st speed travel time	hour	(Travel operation judgment = ON) + (2nd speed travel SOL = OFF)	Engine in operation
HI-SPEED	2nd speed travel time	hour	(Travel operation judgment = ON) + (2nd speed travel SOL = ON)	Engine in operation
SOLO	Independent travel time	hour	(Travel judgment = ON) + (Upper judgment = OFF)	Engine in operation
OPT.LINE OPR. TIME	1st (both with and without 2 pumps flow) option operation time	hour	1st option operation judgment = ON	Engine in operation
ONE-PUMP FLOW	1st option operation (without 2 pumps flow) time	hour	(1st option operation judgment = ON) + (2 pumps flow SOL = OFF)	Engine in operation
TWO-PUMP FLOW	1st option operation (with 2 pumps flow) time	hour	(1st option operation judgment = ON) + (2 pumps flow SOL = ON)	Engine in operation
2nd OPT.LINE OPR. TIME	2nd option operation time	hour	2nd option operation judgment = ON	Engine in operation

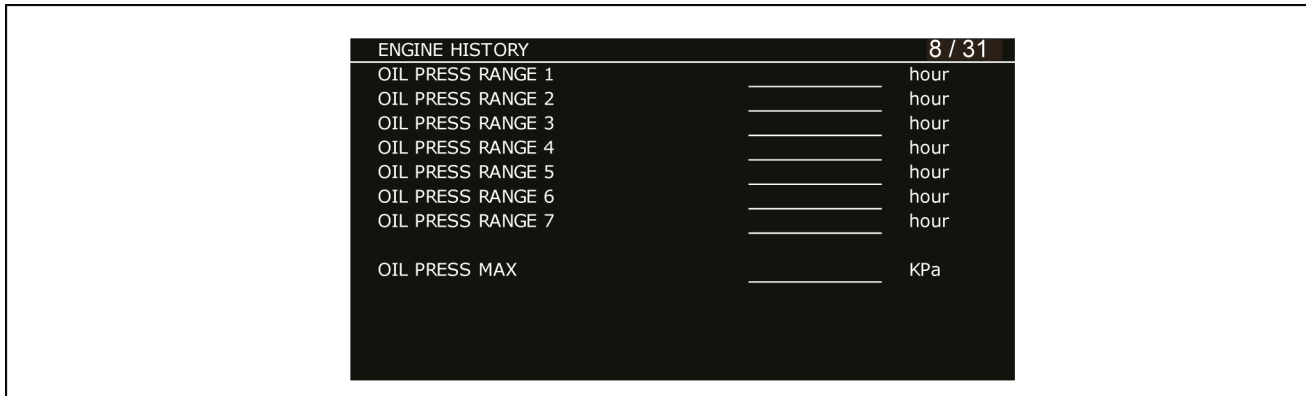

SMIL14CEX0980EA 67

Display	Explanation	Unit	Judgment condition	Judgment start condition
OIL PRESS RANGE 1	Oil pressure; time distribution	hour	Less than 0 kPa	In 10 s after the engine starts
OIL PRESS RANGE 2	Oil pressure; time distribution	hour	Less than 150 kPa	In 10 s after the engine starts
OIL PRESS RANGE 3	Oil pressure; time distribution	hour	Less than 300 kPa	In 10 s after the engine starts
OIL PRESS RANGE 4	Oil pressure; time distribution	hour	Less than 450 kPa	In 10 s after the engine starts
OIL PRESS RANGE 5	Oil pressure; time distribution	hour	Less than 600 kPa	In 10 s after the engine starts
OIL PRESS RANGE 6	Oil pressure; time distribution	hour	Less than 750 kPa	In 10 s after the engine starts
OIL PRESS RANGE 7	Oil pressure; time distribution	hour	750 kPa or more	In 10 s after the engine starts
OIL PRESS MAX	Maximum value of oil pressure	kPa (psi)	–	In 10 s after the engine starts

Intake throttle control test

Purpose

- To check the intake throttle operation.

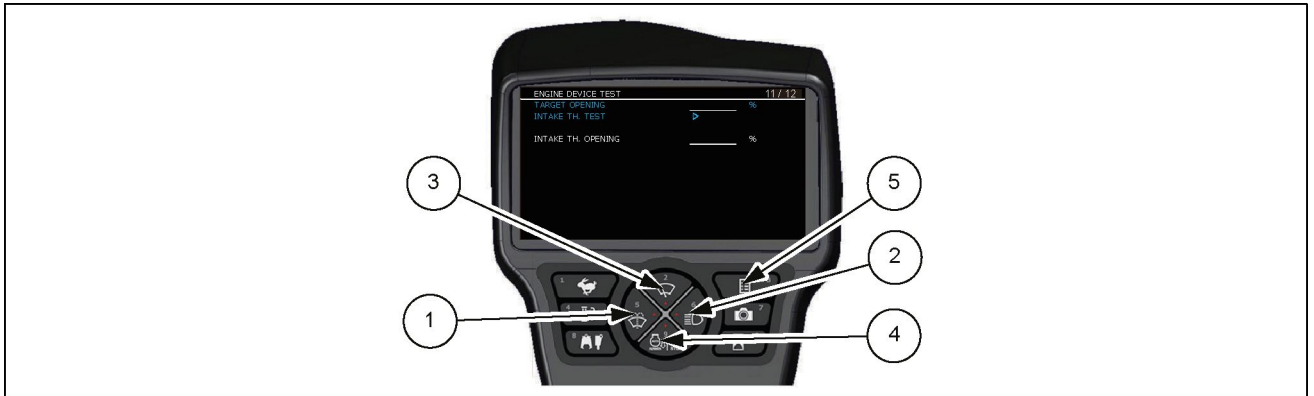

SMIL14CEX1108EB 101

Display	Explanation	Unit	Remarks
TARGET OPENING	Degree of opening of target intake throttle	%	Items selectable. The degree of opening of the VG turbo can be specified. Initial value: 50.0
INTAKE TH. TEST	Intake throttle test	–	The intake throttle is driven (for 10 s).
INTAKE TH. OPENING	Intake throttle opening (degree)	%	

Condition for the test

- The key is ON, or the engine is running [**700 RPM** or less].

Setting the target intake throttle valve (%)

- Select "TARGET OPENING" (target intake throttle) using SW **(3)** and **(4)**.
- Press SW **(1)** and **(2)** to set the target test position.
- Available set range: **0 - 100 %**
- After the setting is completed, press SW **(5)**.

Test execution

- Select "INTAKE TH. TEST" (intake throttle test) using SW **(3)** and **(4)**.
- Hold down SW **(2)** for **3 s**, then "▷" changes to "▶" and the test starts.
- The test will be continued for **10 s**.

Test finish

- After **10 s**, the engine automatically returns to the normal state.

Pump flow

Adjust proportional valves of the electronically-controlled pump.

The calibration setup is required when the electronically-controlled pump is replaced.

In this case, the message "INITIAL SETTING INCOMPLETE" does not appear.

1. If an adjustment of the electronically controlled pump is not finished, the (red) initial screen is displayed.

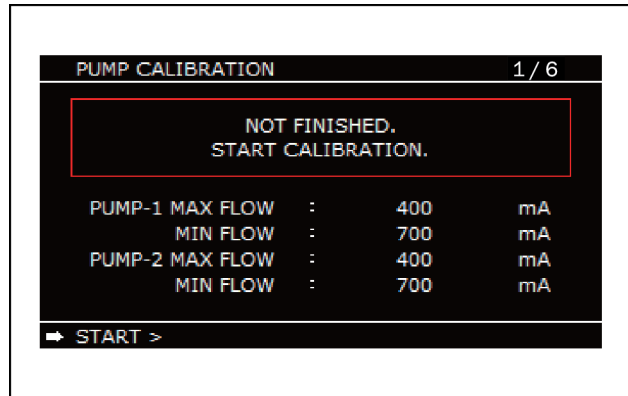

SMIL14CEX6798AA 17

2. When  is pressed, the system displays the engine start screen.

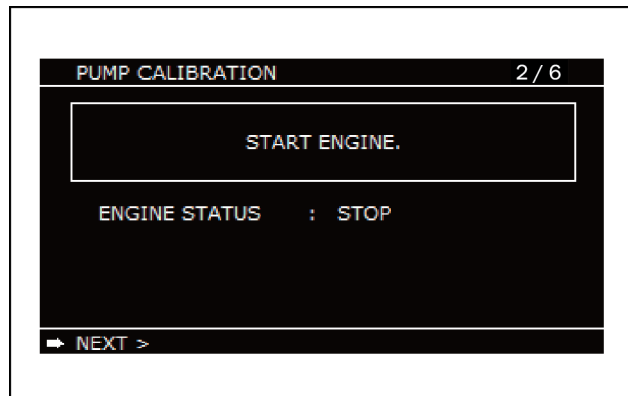

SMIL14CEX6799AA 18

3. When the engine is started and  is pressed, the system displays the SP mode screen.

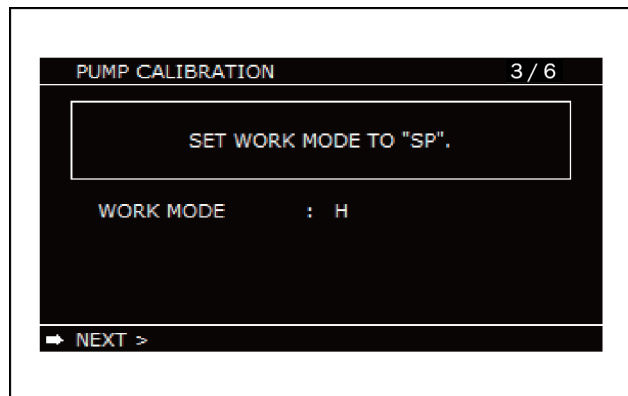

SMIL14CEX6800AA 19

4. When the work mode is turned to the SP mode and  is pressed, the system displays the oil temperature raise screen.

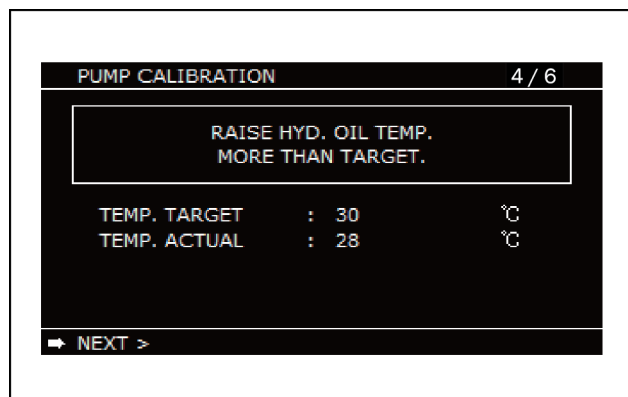

SMIL14CEX6801AA 20

The regulator is usually operated at pilot pressure to achieve the correct flow; however, since the pilot pressure will be interrupted when the control proportional valve is stuck, the regulator is operated at the main pressure to adjust the flow.

Regulator flow selection

The control is based on the electromagnetic proportional valve secondary pressure (normal control)

The lower flow, among the main-controller-computed horsepower flow and negative control flow, is selected as control flow, and the proportional valve secondary pressure is controlled by the selected flow.

Refresh/recirculate actuator

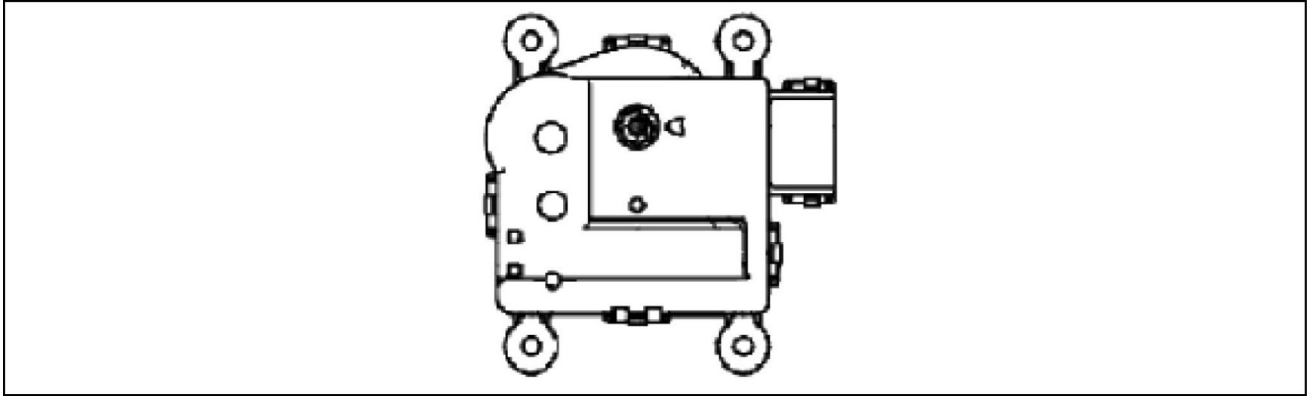

SMIL14CEX1972EA 6

NOTICE: The air conditioning system voltage specifications are **24 V**, but the motor actuator has **12 V** specifications.

The refresh/recirculate switch actuator is installed on the blower intake unit. It opens and closes the refresh/recirculate door via the link.

Built into the refresh/recirculate switch actuator is the potentiometer that switches linked with the actuator shaft.

When the refresh/recirculate door position is determined by the refresh/recirculate switch on the control panel, the control unit reads in the signal of the potentiometer in the actuator and determines whether the motor turns forward or reverse.

The position detection switch also rotates linked with the motor and stops the refresh/recirculate door at the set position.

Blow mode actuator

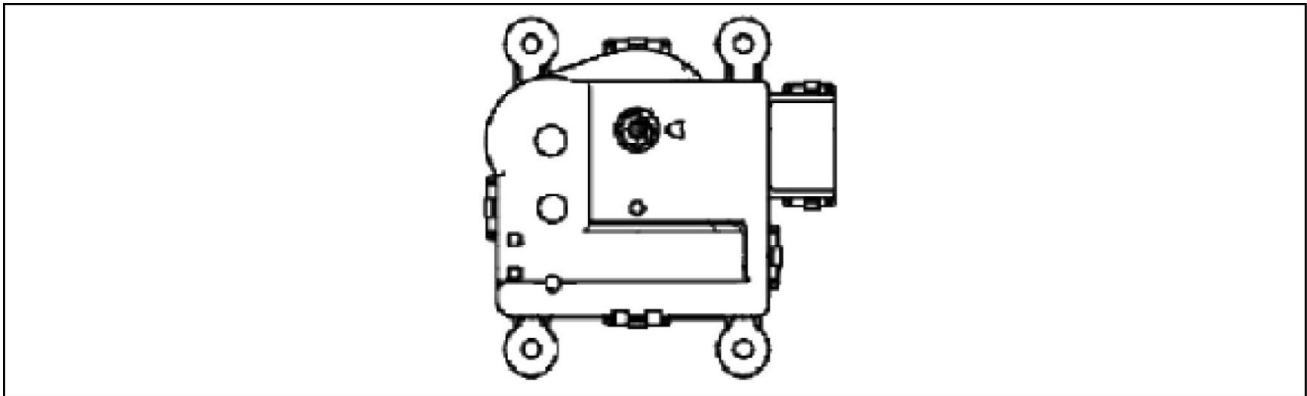

SMIL14CEX1973EA 7

NOTICE: The air conditioning system voltage specifications are **24 V**, but the motor actuator has **12 V** specifications.

The blow mode actuator is installed at the center of the air conditioner unit contained behind the link cover. It opens and closes the mode door via the link.

Built into the blow mode actuator is the potentiometer which switches linked with the actuator shaft.

When blow mode is determined by the temperature control switch, the control unit reads in the potentiometer position in the actuator and determines whether the motor turns forward or in reverse.

The contacts move linked with the motor. When the contacts move open or the control unit output signal goes OFF, the motor stops.



Electrical systems - 55

Camera - 530

**CX250D Crawler excavators LC version (TIER4 FINAL) - NA Market
CX250D Long Reach Crawler excavators LC Long Reach (TIER4 FINAL)
- NA Market**

1. Perform the OBD system check.
2. Turn OFF the starter switch.
3. Connect the DMM between the DLC diagnostic switch terminal and GND.
4. Turn ON the starter switch.
5. Confirm that the voltage displayed on the DMM exceeds the standard value.

Standard: **18 V**

6. Inspect the diagnostic switch circuit between the ECM and DLC using the DMM if it is under the standard value.
 - No open circuit or high resistance should be found.
Standard value: **100 Ω** or less
 - No short circuit with GND should be found.
Standard value: **100 Ω** or more
7. Repair if a problem is discovered.
8. Turn OFF the starter switch.
9. Confirm that there is continuity between the DLC body ground and GND.
10. Turn ON the starter switch.
11. Short the DTC.

NOTE: Short the No.4 terminal and No.12 terminal.

12. Check if the monitor is blinking.

NOTE: If it does not blink, inspect the monitor blinking circuit system.

13. Replace the ECM.
14. After replacing the ECM, perform EGR learning.
15. Turn ON the starter switch.
16. Short the body ground terminal and diagnostic switch terminal of the DLC.
17. Check if the monitor is blinking.
18. Perform the OBD system check.

1464-Main relay performance

Control Module : DCU

Solution:

1. **NOTE:** *If a relevant diagnostic trouble code is set after the following conditions occur, the DCU is normal, and the diagnostic trouble code should simply be cleared.
The battery enters a low voltage condition. If the battery enters a low voltage condition due to cranking or operation of the machine's electronic components, the DCU will temporarily turn OFF.
The battery or urea SCR fuse is removed before turning the DCU power supply OFF after turning OFF the ignition switch (during after-run control or within 3 minutes of turning OFF the ignition switch).*

Inspect the DCU harness GND connection terminal for intermittent conditions, improper tightening, or corrosion.

- A. If a problem is found, repair the mounting of the DCU harness GND connection terminal.
 - B. If there are no problems, proceed to Step 2
2. Turn OFF the ignition switch.

Disconnect the DCU harness connector **CN.D1-D2**.

Inspect the DCU harness connector **CN.D1-D2**.

NOTE:

- Make sure that there should be no intermittent conditions, poor connections, or corrosion.
- Make sure that there should be no water intrusion or adhering foreign material.

- A. If a problem is found, repair the connector **CN.D1-D2**.
 - B. If there are no problems, proceed to Step 3
3. Inspect the battery power supply circuit between the urea SCR fuse and the DCU for an open circuit or high resistance.
 - A. If a problem is found, repair the battery power supply circuit or connector.
 - B. If there are no problems, proceed to Step 4
 4. Inspect the DCU GND circuit for an open circuit or high resistance.
 - A. If a problem is found, repair the GND circuit or connector.
 - B. If there are no problems, proceed to Step 5
 5. Replace the DCU. (Refer to “**Dosing control unit - Remove (55.988)** and **Dosing control unit - Install (55.988)**”)
 6. Confirm resolution:

1. Clear the diagnostic trouble code using the trouble diagnosis scan tool.

NOTE:

- After clearing the DCU diagnostic trouble code, observe whether ECM diagnostic trouble code P20C9 is set.
- If diagnostic trouble code P20C9 is set, clear it.

2. Turn OFF the ignition switch until communication with the trouble diagnosis scan tool is discontinued.
3. Turn ON the ignition switch without starting the engine.
4. Observe the diagnostic trouble code information with the trouble diagnosis scan tool. A diagnostic trouble code should not be set.

NOTE: Repeat Step 2 and Step 3 several times, and check if a diagnostic trouble code is set.

5. Observe the diagnostic trouble code information with the trouble diagnosis scan tool. A diagnostic trouble code should not be set.

Harnesses and connectors - Electrical schematic sheet 21 (55.100) Harnesses and connectors - Electrical schematic sheet 15 (55.100)

7. Perform Reverting Valve under Actuator Test with the trouble diagnosis scan tool to check if the reverting valve is stuck.

Replace the urea fluid supply module. (Refer to “ **Diesel Exhaust Fluid (DEF)/AdBlue® supply module - Remove (55.988)** and **Diesel Exhaust Fluid (DEF)/AdBlue® supply module - Install (55.988)**”)

8. Confirm resolution:

1. Clear the diagnostic trouble code using the trouble diagnosis scan tool.

NOTE:

- *After clearing the DCU diagnostic trouble code, observe whether ECM diagnostic trouble code P20C9 is set.*
- *If diagnostic trouble code P20C9 is set, clear it.*

2. Turn OFF the ignition switch until communication with the trouble diagnosis scan tool is discontinued.

3. Turn ON the ignition switch without starting the engine.

4. Observe the diagnostic trouble code information with the trouble diagnosis scan tool. A diagnostic trouble code should not be set.

Harnesses and connectors - Electrical schematic sheet 15 (55.100)

Disconnect bucket close pilot pressure sensor **(2)** connector (3-pin) **CN.D75**.

Measure the resistance between the terminal 1 and terminal 3 of the bucket close pilot pressure sensor **(2)** connector (3-pin) **CN.D75** bucket-close pilot pressure sensor side.

A. If the resistance is not about **10 kΩ**, replace bucket close pilot pressure sensor **(2)**.

B. If the resistance is about **10 kΩ**, proceed to Step 7.

7. Inspect for continuity between the ground and terminal 1 of the bucket close pilot pressure sensor **(2)** connector (3-pin) **CN.D75** (harness side).

Inspect for continuity between the ground and terminal 2 of the bucket close pilot pressure sensor **(2)** connector (3-pin) **CN.D75** (harness side).

A. If there is continuity, find and replace the short circuit on the wire ID WL435h, WL435 and GW410.

B. If there is no continuity, proceed to Step 8.

8. Inspect for continuity between the ground and terminal 3 of the bucket close pilot pressure sensor **(2)** connector (3-pin) **CN.D75** (harness side).

A. If there is no continuity, find and repair/replace the open circuit on the wire ID BW445h and BW445.

B. If there is continuity, proceed to Step 9.

9. Turn the key switch ON.

Measure the voltage between the ground and terminal 1 of the bucket close pilot pressure sensor **(2)** connector (3-pin) **CN.D75** (harness side).

A. If the voltage is not about **5 V**, find and repair/replace the open circuit on the wire ID WL435h and WL435.

B. If the voltage is about **5 V**, proceed to Step 10.

10. Measure the voltage between the ground and terminal 2 of the bucket close pilot pressure sensor **(2)** connector (3-pin) **CN.D75** (harness side).

A. If the voltage is less than **0.25 V**, find and repair/replace the open circuit on the wire ID GW410.

B. If the voltage is more than or equal to **0.25 V**, replace the main controller **(1)**.

7. Inspect for continuity between the terminals 2 of the connector **CN.D65** harness side and 11 of the connector **CN.A2** harness side.
 - A. If there is continuity, replace the main controller **(1)**.
 - B. If there is no continuity, repair or replace the VG902b and BO902b harnesses.

7608-Camera abnormality

Control Module : MCM

Solution:

1. Use the below image for the fault code resolution process:

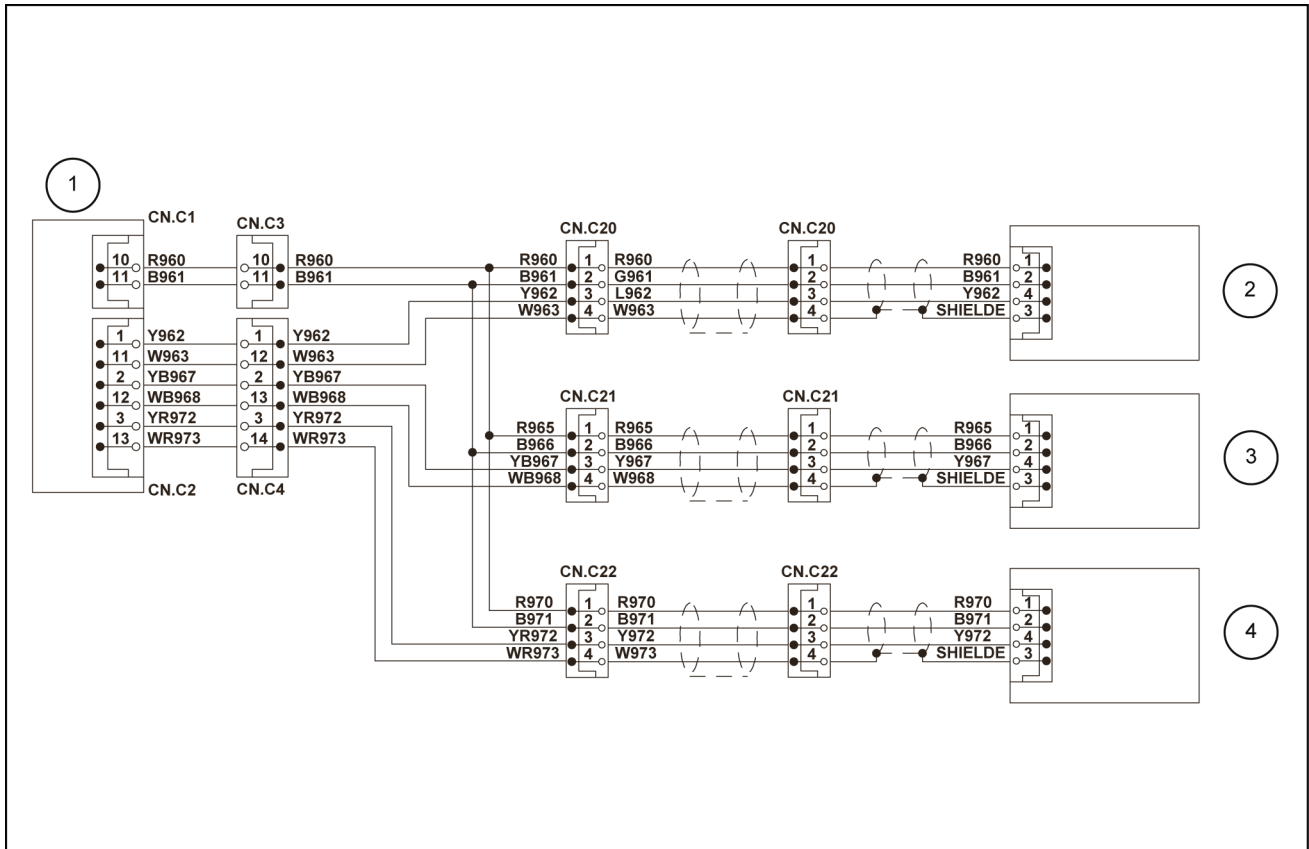

SMIL15CEX1896FB 1

1. Main controller
 2. Monitor
 3. Camera 1 (rear)
 4. Camera 2 (right)
 - a. CAN communication
2. Turn the key switch ON.
Inspect the connection status of each connector. Make sure that all the connectors are secured.
 - A. If diagnostic trouble code 7608 is displayed, proceed to Step 3.
 3. Turn the key switch OFF.
Disconnect the connectors **CN.C1**, **CN.C2**, **CN.C20**, **CN.C21** and **CN.C22**.
Inspect the continuity between the terminal 10 of the connector **CN.C1** harness side and terminal 1 of the connector **CN.C20** harness side and terminal 1 of the connector **CN.C21** harness side or terminal 1 of the **CN.C22** harness side.
 - A. If there is no continuity, repair or replace the open circuit R960, R965, or R970 harnesses.
 - B. If there is continuity, proceed to Step 4.
 4. Inspect the continuity between the terminal 11 of the connector **CN.C1** harness side and terminal 2 of the connector **CN.C20** harness side and terminal 2 of the connector **CN.C21** harness side or terminal 2 of the **CN.C22** harness side.

- B. If there are no problems, proceed to Step 7
7. Inspect for poor connections at the ECM harness connector **CN.D3**.
- A. If a problem is found, repair the harness connector **CN.D3**.
- B. If the harness connector **CN.D3** is normal, replace the ECM. (Refer to “ **Engine Control Unit (ECU) - Remove (55.015)** and **Engine Control Unit (ECU) - Install (55.015)**”)
8. Set the Injector ID Code, fuel delivery rate and engine number for the ECM.
9. Confirm resolution:
1. Clear the diagnostic trouble code using the trouble diagnosis scan tool.
 2. Turn OFF the ignition switch for at least **30 s**.
 3. Start the engine.
 4. Perform a test-run under the conditions for running the diagnostic trouble code.

NOTE:

- *Conditions for setting engine run time or coolant temperature vary depending on the diagnostic trouble codes.*
- *For the conditions for setting the diagnostic trouble code, refer to the applicable code listed in 15E diagnostic trouble code information.*

5. Use the trouble diagnosis scan tool to confirm that a diagnostic trouble code has not been detected.

Harnesses and connectors - Electrical schematic sheet 22 (55.100) Harnesses and connectors - Electrical schematic sheet 13 (55.100)

- B. If a problem is found, repair the harness connector **CN.E15**.
 - C. If the harness connector **CN.E15** is normal, inspect the CMP sensor. (Refer to “ **Engine timing sensors Camshaft sensor - Inspect (55.015)**”)
 - D. If a problem is found, replace the CMP sensor. (Refer to “ **Engine timing sensors Camshaft sensor - Remove (55.015)** and **Engine timing sensors Camshaft sensor - Install (55.015)**”)
 - E. If there are no problems, proceed to Step 7
7. Inspect the camshaft gear.
- Make sure that camshaft gear is not damaged.
 - Make sure that camshaft gear is installed correctly.
- A. If a problem is found, repair the camshaft gear.
 - B. If there are no problems, proceed to Step 8
8. Inspect the GND circuit between the ECM and the CMP sensor for an open circuit and high resistance.

NOTE:

- *The CMP sensor shares the GND circuit with other sensors.*
- *The diagnostic trouble code set on a sensor which shares this circuit may be detected.*

- A. If a problem is found, repair the GND circuit.
 - B. If there are no problems, proceed to Step 9
9. Inspect the ECM harness connector **CN.D4** for a poor connection.
- A. If a problem is found, repair the harness connector **CN.D4**.
 - B. If the harness connector **CN.D4** is normal, replace the ECM .(Refer to “ **Engine Control Unit (ECU) - Remove (55.015)** and **Engine Control Unit (ECU) - Install (55.015)**”)
10. Set the Injector ID Code, fuel delivery rate and engine No. for the ECM.
11. Confirm resolution:
- 1. Clear the diagnostic trouble code using the trouble diagnosis scan tool.
 - 2. Turn OFF the ignition switch for at least **30 s**.
 - 3. Start the engine.
 - 4. Perform a test-run under the conditions for running the diagnostic trouble code.

NOTE:

- *Conditions for setting engine run time or coolant temperature vary depending on the diagnostic trouble codes.*
- *For the conditions for setting the diagnostic trouble code, refer to the applicable code listed in 15E diagnostic trouble code information.*

- 5. Use the trouble diagnosis scan tool to confirm that a diagnostic trouble code has not been detected.

Harnesses and connectors - Electrical schematic sheet 19 (55.100) Harnesses and connectors - Electrical schematic sheet 14 (55.100)

P0687-ECM power relay control circuit high

Control Module : ECM

Solution:

1. Turn OFF the ignition switch.

Remove the main relay.

Turn ON the ignition switch.

Use the trouble diagnosis scan tool to see if diagnostic trouble code P0685 is detected.

- A. If the diagnostic trouble code P0685 is not detected, repair the short circuit to the battery power supply of the power supply circuit between the ECM and main relay.
 - B. If the diagnostic trouble code P0685 is detected, proceed to Step 2.
2. Turn OFF the ignition switch for at least **30 s**.

Replace the main relay with a glow relay or normal relay.

Turn ON the ignition switch.

Use the trouble diagnosis scan tool to check if diagnostic trouble code P0687 has been detected.

- A. If the diagnostic trouble code P0687 is not detected, replace the main relay.
3. Confirm resolution:
 1. Clear the diagnostic trouble code using the trouble diagnosis scan tool.
 2. Turn OFF the ignition switch for at least **30 s**.
 3. Turn ON the ignition switch.
 4. Use the trouble diagnosis scan tool to confirm that a diagnostic trouble code has not been detected.

4. Confirm that the trouble diagnosis scan tool does not show a value at or below **0.2 V** while depressing and then releasing the pedal.

5. Use the trouble diagnosis scan tool to confirm that a diagnostic trouble code has not been detected.

Harnesses and connectors - Electrical schematic sheet 38 (55.100) Harnesses and connectors - Electrical schematic sheet 11 (55.100)

Index

Electrical systems - 55

FAULT CODES - DTC

0002-CAN Bus off	11
0100-Lost communication with ECM	13
029D-Lost communication with NOx sensor 1	8
0607-Control module performance	15
060B-Internal control module A/D processing performance	16
062F-Control module EEPROM error	17
0641-Sensor reference voltage 1 circuit	19
0658-Actuator supply voltage circuit	21
0659-Actuator supply voltage circuit	23
1462-Urea fluid quality sensor timeout error	25
1464-Main relay performance	27
1468-DCU overtemperature	29
1491-Urea fluid overpressure	30
1493-DCU driver overtemperature	32
149C-Urea fluid pressure reduction malfunction	33
149D-Urea fluid tank overtemperature	35
203B-Urea Fluid Tank Level Sensor Stuck	37
203C-Urea fluid tank level sensor low voltage	39
203D-Urea fluid tank level sensor high voltage	41
2048-Urea fluid injector circuit low voltage	43
2049-Urea fluid injector circuit high voltage	45
204B-Urea fluid pressure sensor performance	47
204C-Urea fluid pressure sensor circuit low voltage	49
204D-Urea fluid pressure sensor circuit high voltage	51
205B-Urea fluid tank temperature sensor performance	53
205C-Urea fluid tank temperature sensor low voltage	54
205D-Urea fluid tank temperature sensor high voltage	56
206A-Urea fluid quality sensor circuit	58
206B-Urea sensor over temperature condition	59
206C-Urea fluid quality sensor circuit low voltage	61
206D-Urea fluid quality sensor circuit high voltage	63
207F-Urea fluid concentration too low	64
208A-Urea fluid pump control circuit	65
208B-Urea fluid pump performance	67

11. Bucket and arm installation section

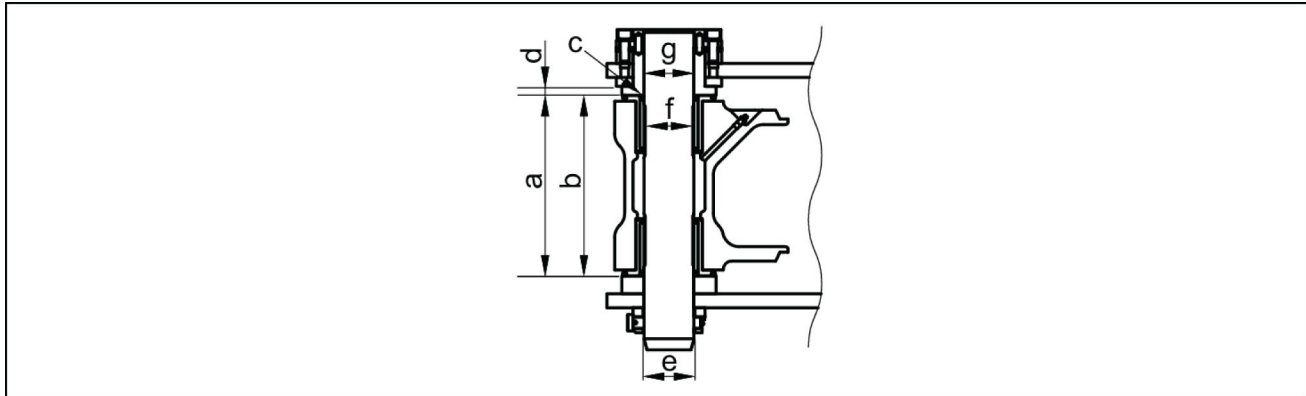

SMIL13CEX2719EA 12

Part name	Code	Standard value	Usage limits	Judgment	Solution
Bucket	a	254 mm (10.00 in)	260 mm (10.24 in)	Acceptable/ Unacceptable	Replacement
Arm	b	233 mm (9.17 in)	231 mm (9.09 in)	Acceptable/ Unacceptable	Replacement
Clearance	c	0.7 - 3.8 mm (0.03 - 0.15 in)	Shim adjustment	Acceptable/ Unacceptable	Adjustment with shims
Bushing (bucket)	d	16 mm (0.63 in)	8 mm (0.31 in)	Acceptable/ Unacceptable	Replacement
Pin	e	Ø65 mm (2.56 in)	Ø64 mm (2.52 in)	Acceptable/ Unacceptable	Replacement
Bushing (arm)	f	Ø65 mm (2.56 in)	Ø66.5 mm (2.62 in)	Acceptable/ Unacceptable	Replacement
Bushing (bucket)	g	Ø65 mm (2.56 in)	Ø66.5 mm (2.62 in)	Acceptable/ Unacceptable	Replacement



SERVICE MANUAL

Platform, cab, bodywork, and decals

**CX250D Crawler excavators LC version (TIER4 FINAL) - NA Market
CX250D Long Reach Crawler excavators LC Long Reach (TIER4 FINAL)
- NA Market**

CLICK HERE TO **DOWNLOAD** THE COMPLETE MANUAL

- Thank you very much for reading the preview of the manual.
- You can download the complete manual from: www.heydownloads.com by clicking the link below



- Please note: If there is no response to CLICKING the link, please download this PDF first and then click on it.

CLICK HERE TO **DOWNLOAD** THE COMPLETE MANUAL