

CX210D
CX210D Long Reach
LC Version
Tier 4B (final)
Crawler Excavator

SERVICE MANUAL

Part number 47961273

3rd edition English

January 2016

Replaces part number 47891797



CLICK HERE TO **DOWNLOAD** THE COMPLETE MANUAL

- Thank you very much for reading the preview of the manual.
- You can download the complete manual from: www.heydownloads.com by clicking the link below



- Please note: If there is no response to CLICKING the link, please download this PDF first and then click on it.

CLICK HERE TO **DOWNLOAD** THE COMPLETE MANUAL

General specification

CX210D Long Reach Crawler excavators LC Long Reach (TIER4 FINAL) - NA Market	NA
---	----

Engine

Type	Water-cooled, 4-cycle diesel, 4-cylinder in line, High pressure common rail system (electric control), Turbocharger with air cooled intercooler, SCR system	
Model	ISUZU AR-4HK1X	
Rated flywheel horse power		
	SAE J1349, ISO 9249	119.3 kW (162.2 Hp) at 1800 RPM
	ISO 14396	124 kW (169 Hp) at 1800 RPM
Piston displacement	5193 cm³ (317 in³)	
Maximum torque		
	SAE J1349, ISO 9249	620 N·m (457 lb ft) at 1600 RPM
	ISO 14396	636 N·m (469 lb ft) at 1600 RPM
Bore and stroke	115 - 125 mm (4.53 - 4.92 in)	
Voltage	24 V	
Alternator	50 A	
Starter	24 V 5.0 kW	

Hydraulic system

Main pumps	2 variable displacement axial piston pumps with regulating system	
	Max. oil flow	2 × 211 L (55.7 US gal) at 1800 RPM
	Working circuit pressure	Boom Up/Arm Out 34.3 MPa (4975 psi)
		with auto power up 37.3 MPa (5410 psi)
		Arm In 23.0 MPa (3336 psi)
		Boom Down 29.4 MPa (4264 psi)
		Bucket 25.0 MPa (3626 psi)
		Swing circuit 24.0 MPa (3481 psi)
	Travel circuit 34.3 MPa (4975 psi)	
Pilot pump	1 gear pump	
	Max. oil flow	18 L (4.8 US gal)
	Working circuit pressure	3.9 MPa (566 psi)
Control valves	With Boom/Arm holding valve	
	One 4-spool valve for Right track travel, Bucket, Boom and Arm acceleration	
	One 5-spool valve for Left track travel, Auxiliary, Swing, Boom acceleration and Arm	
Swing device		
	Motor	Fixed displacement axial piston motor
	Brake	Mechanical disc brake
	Final drive	Planetary gear reduction
	Turn table bearing	Ball bearing type with internal gear
	Maximum swing speed	11.5 RPM
	Swing torque	52200 N·m (38501 lb ft)
Cylinders		
	Boom	2 x Ø 120 mm (4.724 in) - Ø 85 mm (3.346 in) - 1255 mm (49.409 in)
	Arm	1 x Ø 145 mm (5.709 in) - Ø 105 mm (4.134 in) - 1627 mm (64.055 in)
	Bucket	1 x Ø 95 mm (3.740 in) - Ø 65 mm (2.559 in) - 881 mm (34.685 in)
Cooling system		
	Fan	Ø 650 mm (25.6 in) with 7-blades
	Radiator capacity	105.9 kW

Bucket weight

Heavy Duty buckets		
Capacity ISO 7451 (Heaped)	Width	Mass
0.42 m ³ (0.55 yd ³)	610 mm (24 in)	644 kg (1420 lb)
0.56 m ³ (0.73 yd ³)	760 mm (30 in)	739 kg (1630 lb)
0.69 m ³ (0.90 yd ³)	915 mm (36 in)	832 kg (1835 lb)
0.83 m ³ (1.08 yd ³)	1065 mm (42 in)	896 kg (1975 lb)
1.02 m ³ (1.33 yd ³)	1220 mm (48 in)	968 kg (2135 lb)
1.10 m ³ (1.44 yd ³)	1370 mm (54 in)	1050 kg (2315 lb)

Heavy Duty, High Capacity buckets		
Capacity ISO 7451 (Heaped)	Width	Mass
0.57 m ³ (0.75 yd ³)	610 mm (24 in)	680 kg (1500 lb)
0.72 m ³ (0.94 yd ³)	760 mm (30 in)	771 kg (1700 lb)
0.88 m ³ (1.15 yd ³)	915 mm (36 in)	873 kg (1925 lb)
1.05 m ³ (1.37 yd ³)	1065 mm (42 in)	957 kg (2110 lb)
1.22 m ³ (1.60 yd ³)	1220 mm (48 in)	1061 kg (2340 lb)

Severe Duty buckets		
Capacity ISO 7451 (Heaped)	Width	Mass
0.42 m ³ (0.55 yd ³)	610 mm (24 in)	742 kg (1635 lb)
0.56 m ³ (0.73 yd ³)	760 mm (30 in)	850 kg (1875 lb)
0.69 m ³ (0.90 yd ³)	915 mm (36 in)	957 kg (2110 lb)
0.83 m ³ (1.08 yd ³)	1065 mm (42 in)	1030 kg (2270 lb)
1.02 m ³ (1.33 yd ³)	1220 mm (48 in)	1114 kg (2455 lb)

Ditch cleaning buckets		
Capacity ISO 7451 (Heaped)	Width	Mass
0.78 m ³ (1.02 yd ³)	1525 mm (60 in)	454 kg (1000 lb)
		560 kg (1235 lb) (*)
0.93 m ³ (1.22 yd ³)	1830 mm (72 in)	515 kg (1135 lb)
		640 kg (1411 lb) (*)

(*) with bolt-on cutting edge

NOTE: Refer to the Operator's Manual for direct fit buckets application as function of the arm.

Engine - Identification

Engine number

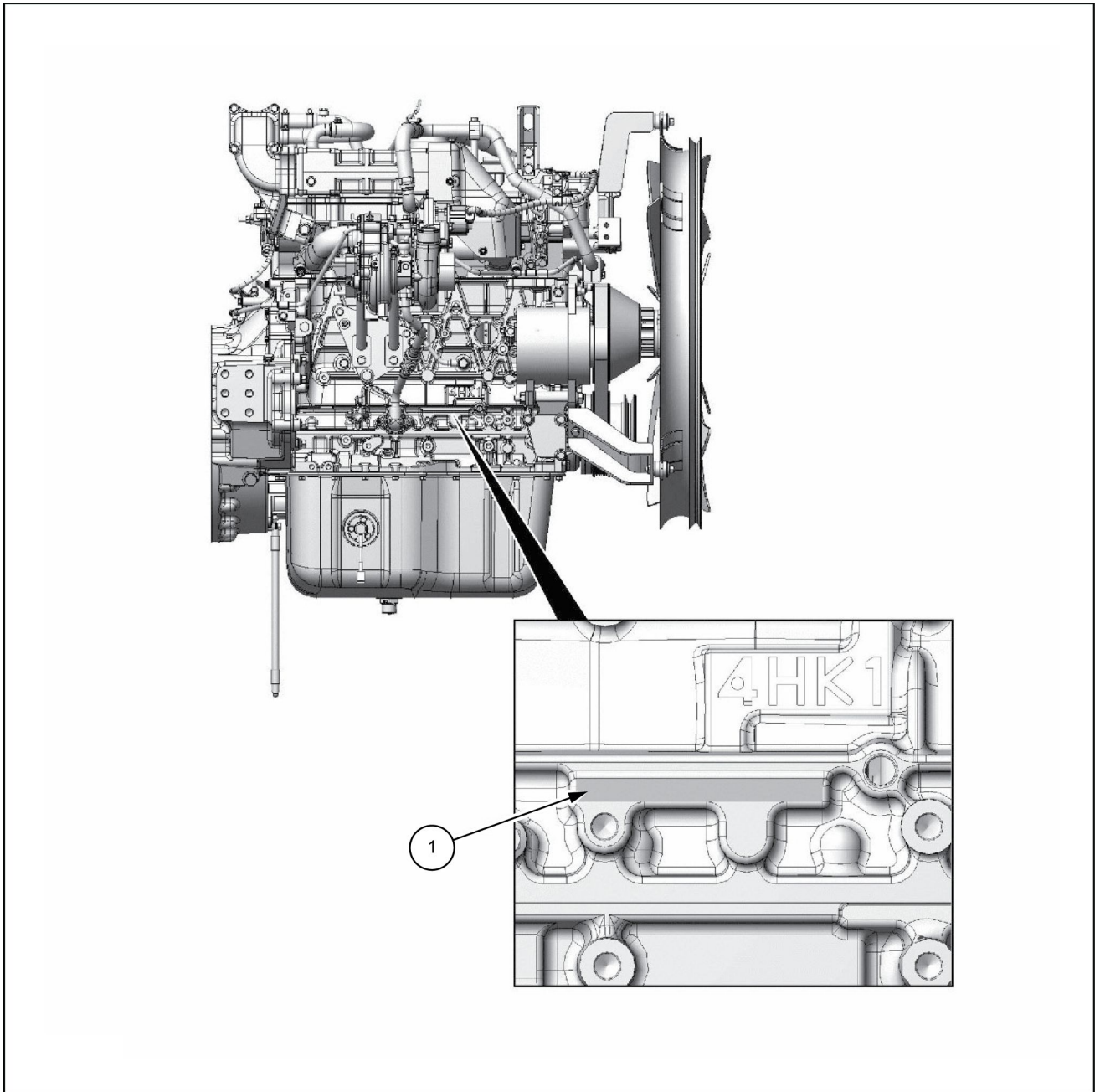

SML13CEX1711GB 1

1. Engine number stamping

Idle gear measurement

1. Align the dial gauge to the idle gear.

NOTE: Attach the dial gauge to the idle gear tooth to be measured.

2. Inspect the backlash.

NOTE: Gently move the gear right and left to read the inconsistency on the dial gauge.

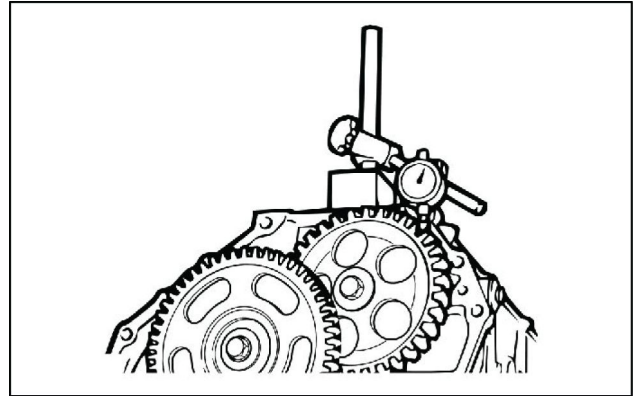

SMIL13CEX1612AA 54

3. Measure the idle gear backlash before removing the idle gear A.

Specified value: **0.10 - 0.17 mm (0.0039 - 0.0067 in)**

Limit: **0.30 mm (0.0118 in)**

4. Replace the idle gear if the measured value exceeds the limit value.
5. Measure the clearance using the feeler gauge.

NOTE: Measure the clearance between the idle gear and the thrust collar.

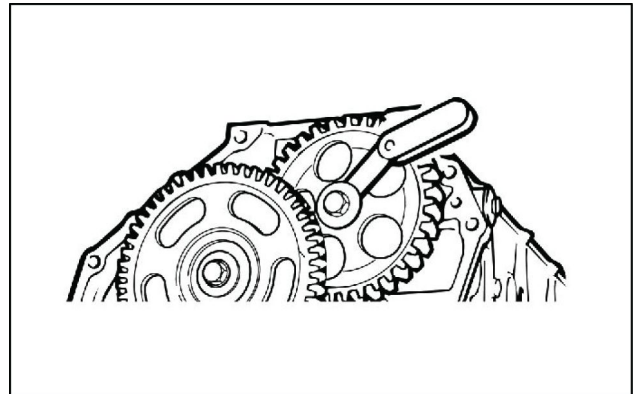

SMIL13CEX1613AA 55

6. Measure the play of the idle gear in the axis direction before removing the idle gear B.

Specified value: **0.080 - 0.155 mm (0.0031 - 0.0061 in)**

Limit: **0.20 mm (0.0079 in)**

7. Replace the idle gear if the measured value exceeds the limit value.

Idle gear A removal

1. Remove the idle gear A from the idle gear A shaft.

6. Install the injector harness to the cylinder head assembly.

NOTE: Tighten the bolts on the bracket and install the injector harness together with the bracket.

Tightening torque: **48 N·m (35 lb ft)**

1. Injector harness terminal
2. Injector harness bracket

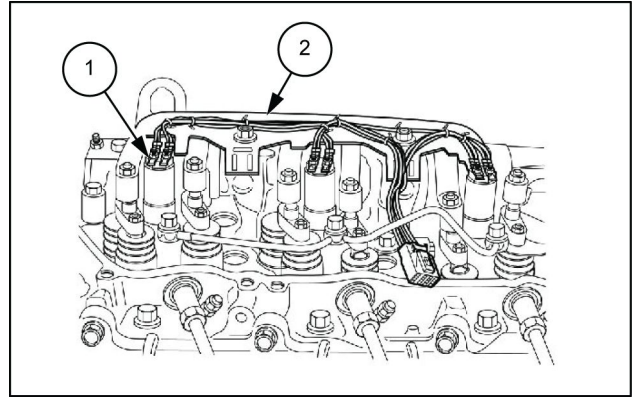

SMIL13CEX1699AB 76

7. Connect the injector harness to the injector.

Tightening torque: **2 N·m (1.48 lb ft)**

NOTE: Be careful not to damage the injector side stud bolts.

1. Lower cover
2. Connector

8. Install the connector to the lower cover.

Tightening torque: **2 N·m (1.48 lb ft)**

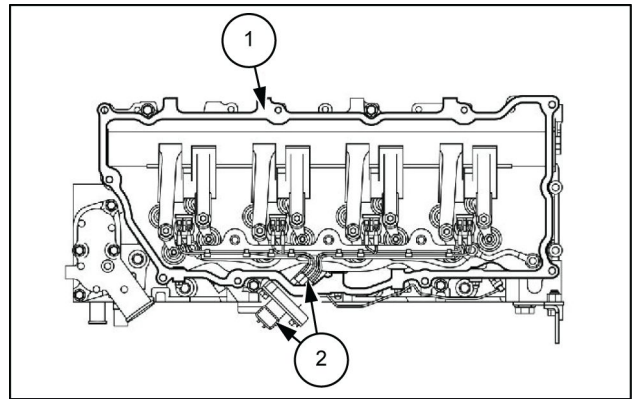

SMIL13CEX1700AB 77

Glow plug installation

1. Install the glow plug to the cylinder head assembly.

Tightening torque: **20 N·m (15 lb ft)**

NOTICE: Be careful not to exceed the specified torque when tightening.

2. Install the glow plug connector to the glow plug.

Tightening torque: **1 N·m (0.74 lb ft)**

NOTE: Confirm that the glow plug connector does not interfere with the surrounding parts.

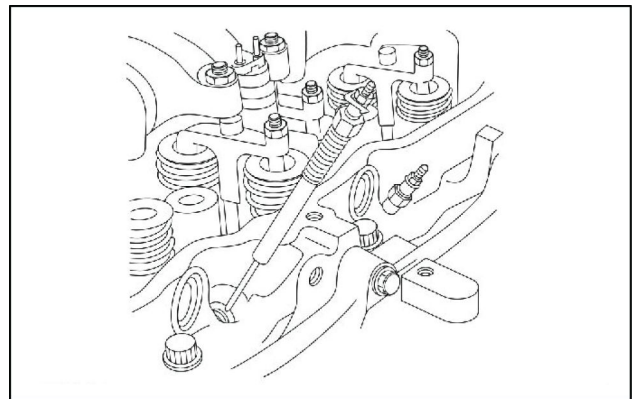

SMIL13CEX1801AB 78

Cylinder head cover installation

1. Align the head cover gasket (2) to the cylinder head cover (1).

2. Install the cylinder head cover (1) to the lower cover (3).

Tightening torque: **18 N·m (13 lb ft).**

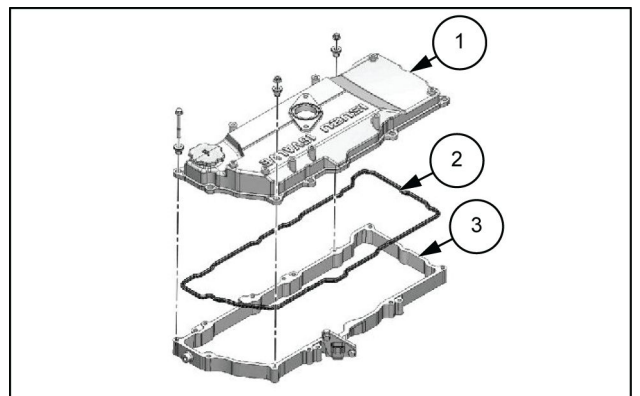

SMIL13CEX1803AB 79

Lower cover removal

1. Remove the connector (1) from the lower cover.

NOTICE: Do not pull the wire, or pry the connector with a screwdriver.

2. Disconnect the injector harness from the injector.

NOTICE: Be careful not to damage the injector side stud bolts.

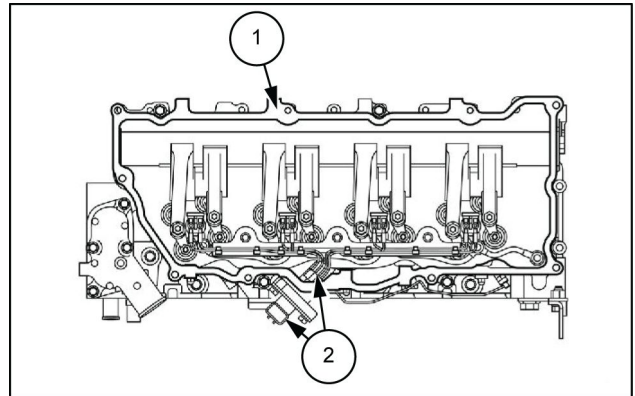

SMIL13CEX1148AB 3

3. Remove the injector harness from the cylinder head assembly.

NOTE: Remove the bracket tightening bolts and then remove the injector harness together with the bracket.

4. Remove the lower cover (2) from the cylinder head assembly.
5. Remove the gasket from the lower cover.
6. Remove the rubber plug from the cylinder head assembly.

Rocker arm shaft removal

1. Loosen the adjust screw using a wrench.

NOTE: Loosen all valve clearance adjustment screws.

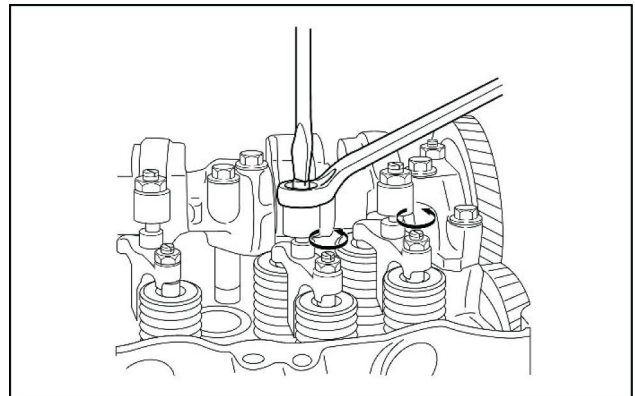

SMIL13CEX1153AA 4

2. Remove the rocker arm shaft from the cylinder head assembly.

NOTE: Evenly loosen the rocker arm shaft bracket and the rocker arm assembly bracket tightening bolts from both ends and remove them.

NOTICE: Be careful not to remove the bolt shown in the diagram.

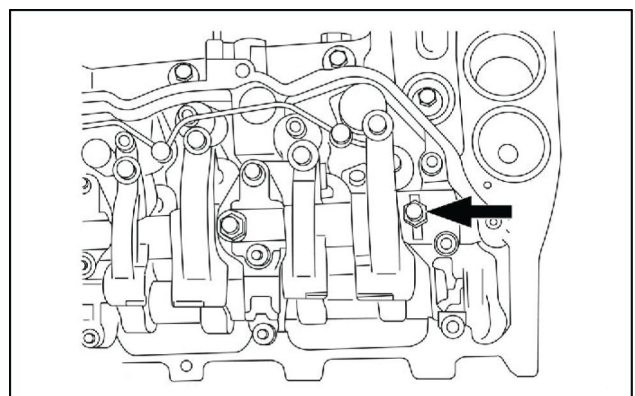

SMIL13CEX1154AA 5

4. Align No. 1 cylinder to the compression top dead center.

1. Front cover marking
2. 0° marking on the crankshaft damper

5. Install the O-ring to the fuel supply pump.

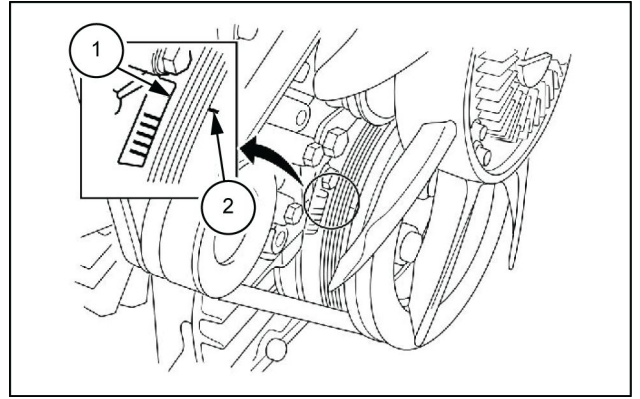

SMIL13CEX1668AB 20

6. Temporarily tighten the fuel supply pump to the cylinder block by means of the bolt (1).

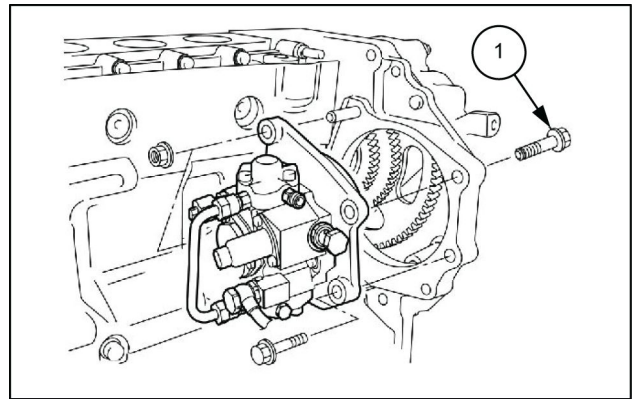

SMIL13CEX1669AB 21

7. Check alignment mark of the supply pump gear.

NOTE: Confirm that the alignment mark (2) can be seen through the plug hole (1) on the left side of the flywheel housing.

NOTE: If the alignment mark could not be confirmed, adjust the position of the supply pump gear.

8. Securely tighten the fuel supply pump to the cylinder block.

Tightening torque: **50 N·m (37 lb ft)** nut

Tightening torque: **76 N·m (56 lb ft)** bolt

9. Connect the harness connector to the fuel supply pump.

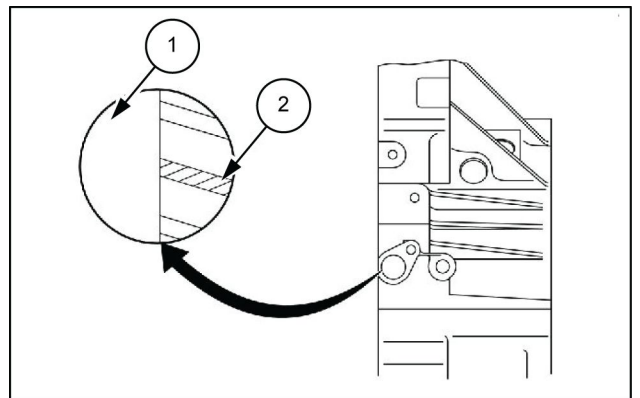

SMIL13CEX1670AB 22

Index

Engine - 10

Valve drive and gears - 106

Camshaft - Assemble	71
Camshaft - Disassemble	68
Camshaft - Inspect	69
Camshaft - Install	72
Camshaft - Remove	65
Idler gear - Inspect	33
Idler gear - Install	34
Idler gear - Remove	16
Rocker shaft - Assemble	8
Rocker shaft - Disassemble	5
Rocker shaft - Inspect	6
Rocker shaft - Install	10
Rocker shaft - Remove	3

- Temporarily tighten the inlet cover **(4)** to the cylinder head assembly.

NOTE: Do not forget to install the bolts indicated by the arrow in the diagram. Completely tighten the installation bolt and nut when installing the common rail assembly.

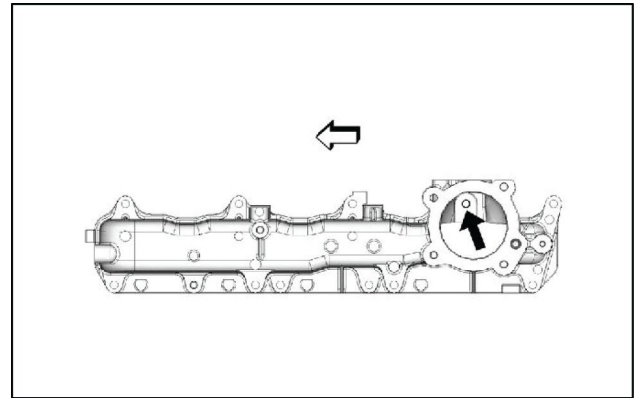

SMIL13CEX1403AA 29

- Install the case **(2)** with the gasket **(3)** to the inlet cover **(4)**.

Tightening torque: **22 N·m (16.23 lb ft)**

Install it together with the EGR pipe D **(1)**.

Engine hanger bracket installation

- Install the front engine hanger bracket **(2)** to the cylinder head assembly.

Tightening torque: **104 N·m (76.71 lb ft)** Front engine hanger bracket **(2)**

Tightening torque: **48 N·m (35.40 lb ft)** Front engine hanger **(1)**

- Install the rear engine hanger bracket **(4)** to the cylinder head assembly.

Tightening torque: **104 N·m (76.71 lb ft)** Rear engine hanger bracket **(4)**

Tightening torque: **48 N·m (35.40 lb ft)** Rear engine hanger **(3)**

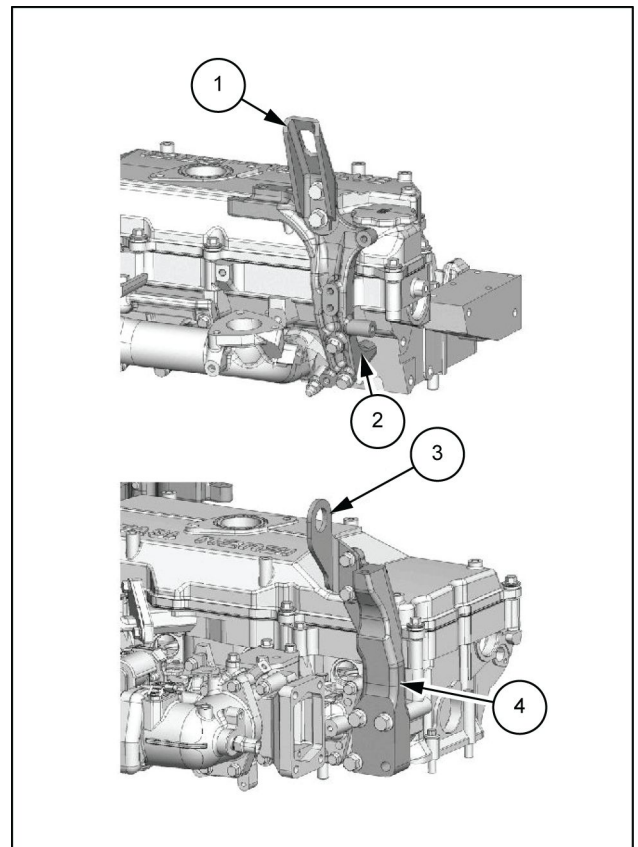

SMIL13CEX1405BB 30

Rocker arm shaft adjustment

1. Valve clearance adjustment

- Adjust the valve clearance while cool.
- Loosen all adjust screws before adjustment.

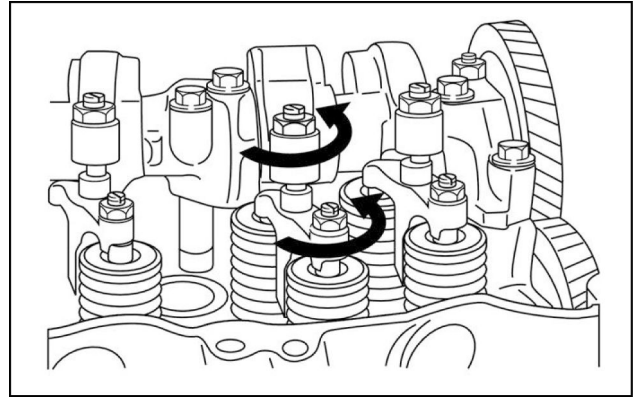

SMIL14CEX3082AA 12

2. Align No.1 cylinder to the compression top dead center.

1. Front cover marking
2. 0° marking on the crankshaft damper

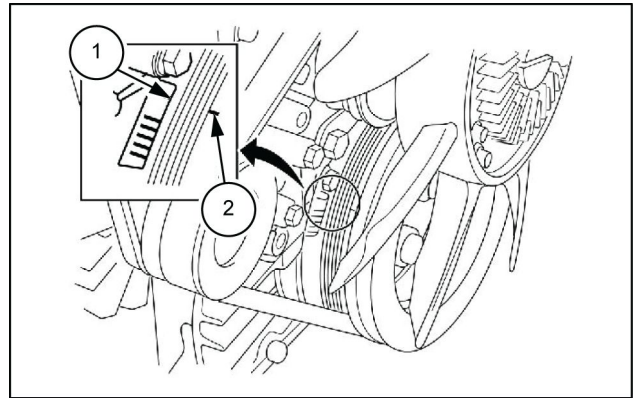

SMIL13CEX1690AB 13

3. Prepare the feeler gauge.

Thickness : **0.4 mm (0.0157 in)**

NOTE: Insert the thickness gauge between the rocker arm and bridge cap.

4. Turn the adjust screw.

NOTE: When the movement of the thickness gauge becomes stiff, secure the adjust screw nut of the rocker arm.

Tightening torque: **22 N·m (16 lb ft)**

5. Turn the adjust screw.

6. With the thickness gauge inserted, lightly tighten the adjust screw of the bridge.

7. Confirm that the leading end of the adjust screw and valve shaft end have made contact and the movement of the thickness gauge has become stiff.

8. Check if the valve shaft end on the opposite side is floating or touching at an angle.

9. If it is floating or touching at an angle, slightly loosen the bridge adjust screw and adjust the valve shaft ends on both sides to touch properly.

Clearance : Less than **0.1 mm (0.0039 in)** between valve and bridge

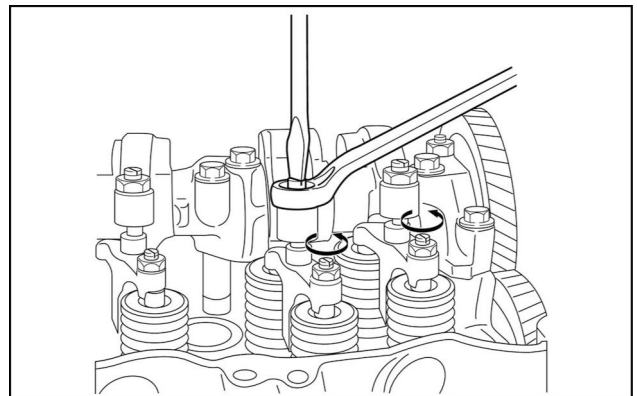

SMIL14CEX3083AA 14

Piston - Inspect

Piston ring inspection

1. Clean the inspection target section thoroughly before starting inspection.

NOTE: Clearance inspection of the piston ring joint

2. Press the piston ring using the piston.

NOTE: Press the piston ring into the bottom end of the cylinder block.

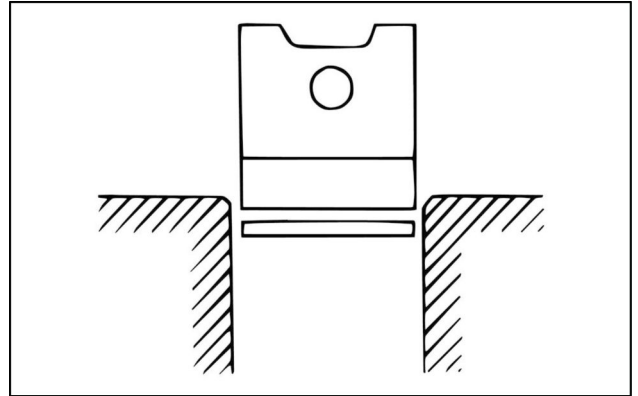

SMIL14CEX3369AA 1

3. Measure the clearance using the feeler gauge.

Piston ring joint		
Parts	Standard value	Limit value
Top ring	0.1800 - 0.2800 mm (0.0071 - 0.0110 in)	1.2 mm (0.0472 in)
Second ring	0.35 - 0.50 mm (0.0138 - 0.0197 in)	
Third ring	0.35 - 0.50 mm (0.0138 - 0.0197 in)	
Oil ring	0.15 - 0.35 mm (0.006 - 0.014 in)	

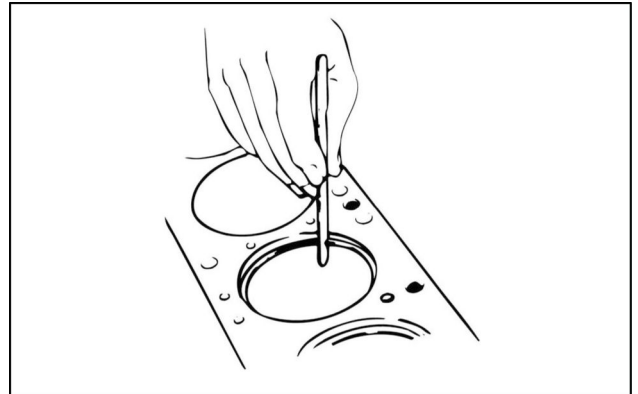

SMIL14CEX3370AA 2

4. Replace the piston ring if the measured value exceeds the limit value.

5. Measure the clearance using the feeler gauge:

NOTE: Measurement of the clearance between the piston ring groove and the piston ring.

Clearance between the piston ring groove and the piston ring		
Parts	Standard value	Limit value
Top ring	0.057 - 0.097 mm (0.0022 - 0.0038 in)	0.2 mm (0.0079 in)
Second ring	0.085 - 0.120 mm (0.0033 - 0.0047 in)	
Third ring	0.085 - 0.120 mm (0.0033 - 0.0047 in)	
Oil ring	0.020 - 0.060 mm (0.0008 - 0.0024 in)	

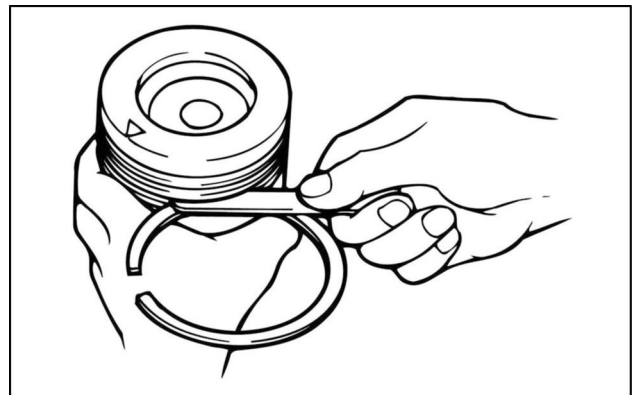

SMIL14CEX3371AA 3

6. Replace the piston and the piston ring if the measured value exceeds the limit value.

Index

Engine - 10

Connecting rods and pistons - 105

Piston - Assemble	27
Piston - Disassemble	18
Piston - Inspect	19
Piston - Install	29
Piston - Remove	4
Piston - Special tools	3

Flywheel removal

1. Remove the flywheel from the crankshaft.

NOTE: Gradually loosen the flywheel installation bolts in the order shown in the diagram.

NOTE: Fix the flywheel firmly so that it will not rotate.

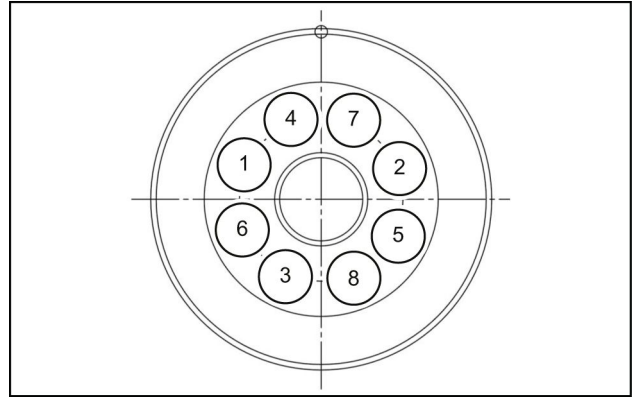

SMIL14CEX3132AB 49

Crankshaft rear oil seal removal

1. Remove the crankshaft rear oil seal (3) from the crankshaft using the special tool.

1. Felt
2. Slinger

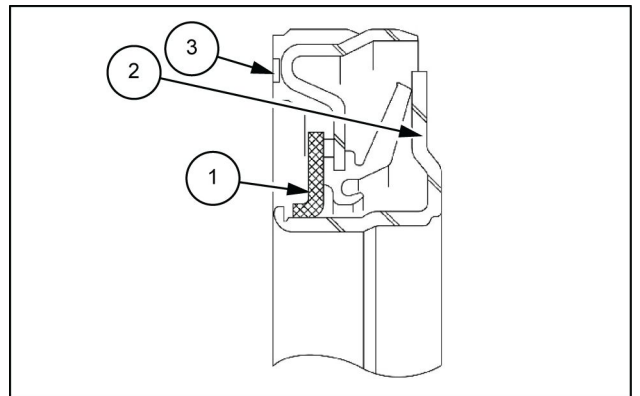

SMIL13CEX1469AB 50

Special tool: Slinger puller (Refer to **Crankshaft - Special tools (10.103)**)

NOTICE: Be careful not to damage the oil seal pressfitting surface.

NOTE: Remove the slinger and oil seal together. If the slinger of the remover is easy to come off, the outer circumference of the jig can be tightened using a clip band to improve the workability.

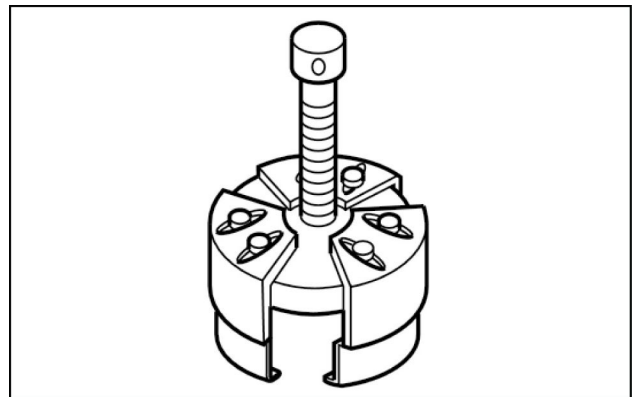

SMIL14CEX3125AA 51

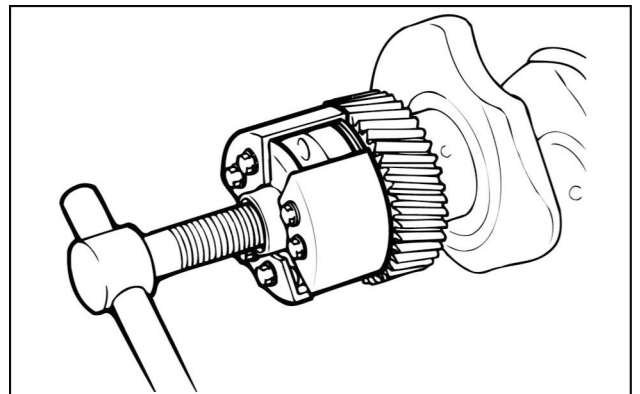

SMIL14CEX3133AA 52

EGR valve installation

1. Install the EGR valve (3) to the EGR pipe D (4).

Tightening torque: **24 N·m (18 lb ft)**

1. EGR cooler C
2. EGR pipe C

NOTE: Use new gaskets.

2. Connect the harness connector to the EGR valve (3).

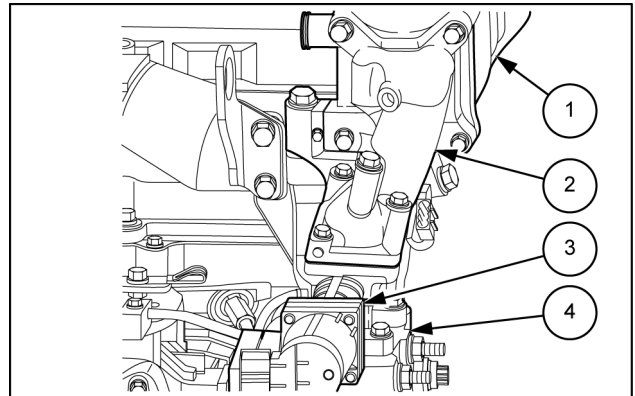

SMIL14CEX5656AB 82

EGR cooler assembly installation

1. Temporarily tighten the EGR pipe C (2) to the EGR valve (1).
2. Temporarily tighten the EGR cooler B (3) to the EGR pipe C (2).
3. Temporarily tighten the EGR pipe B (4) to the EGR cooler B (3).
4. Temporarily tighten the EGR cooler A (5) to the EGR pipe B (4).
6. EGR pipe D

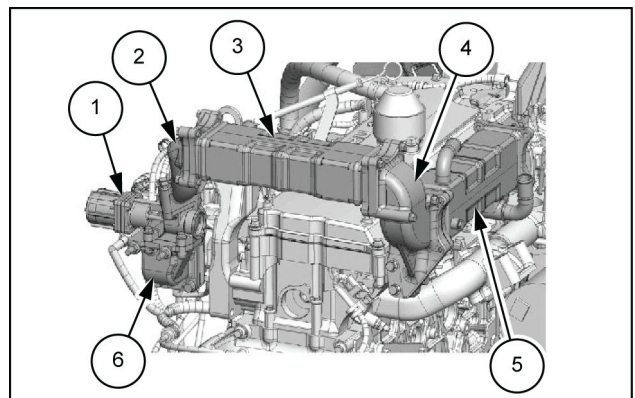

SMIL13CEX1812AB 83

5. Temporarily tighten the EGR pipe A (2) to the EGR cooler A (1) and the exhaust manifold (3).

NOTE: After temporarily tightening all the components, final tighten in the numerical order shown in the diagram.

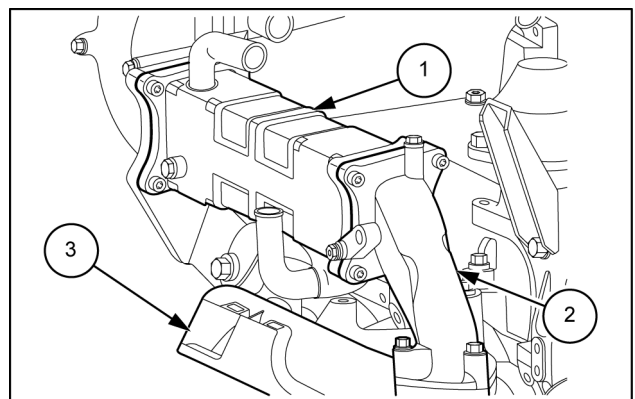

SMIL14CEX5657AB 84

Fuel filters - Remove

Filter assembly

1. Disconnect the harness connector from the fuel filter pressure sensor.
2. Remove the fuel feed hose from the fuel filter.

NOTE: To prevent the fuel leaking, attach a plug on the removed hose.

3. Remove the fuel return hose from the fuel filter.

NOTE: To prevent the fuel leaking, attach a plug on the removed hose.

4. Remove the fuel filter from the machine.

NOTE: Element replaceable specification

1. Priming pump
2. Air bleeding plug
3. Drain plug
4. Case
5. Fuel filter element

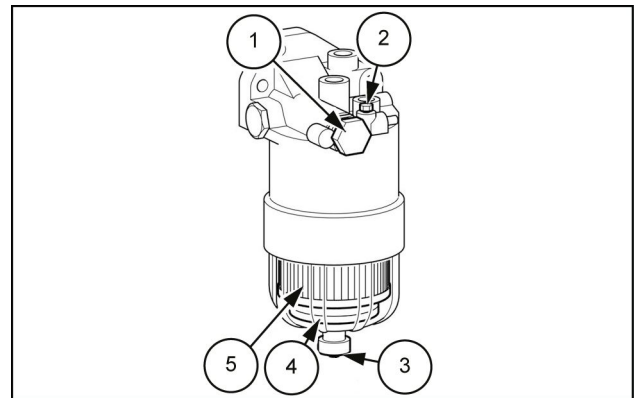

SML14CEX3106AB 1

NOTE: Cartridge-type specification

1. Air bleeding plug
2. Cartridge-type element

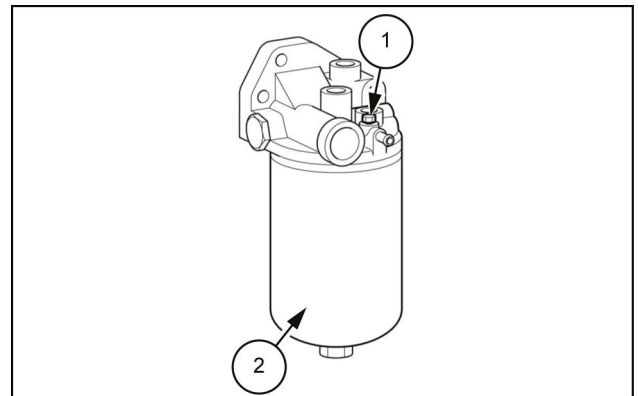

SML14CEX3107AB 2

1. Sliding hammer
2. Fuel injector remover
3. Injector

NOTE: Confirm that the sleeve is not pulled out together when pulling out the injector using a special tool.

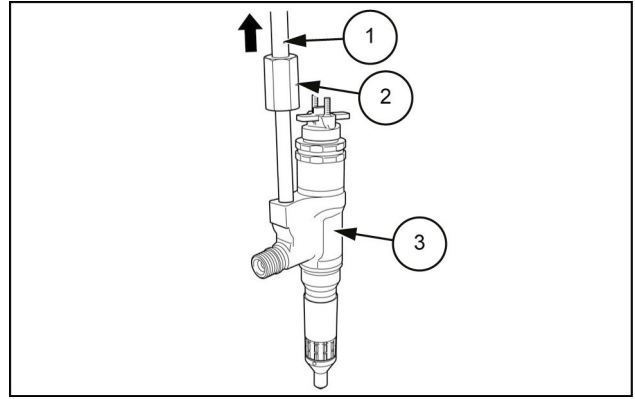

SMIL14CEX3007AB 11

3. Store each ID code plate on the injector head with the cylinder number tag attached to avoid a mix-up.

NOTICE: Be extremely careful not to damage the injector nozzle.

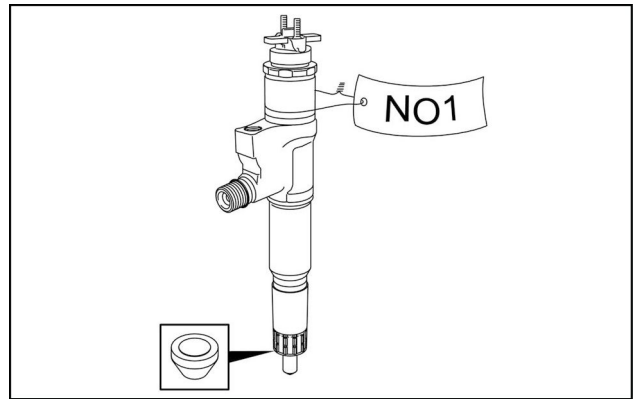

SMIL14CEX3008AA 12

Common rail assembly installation

1. Temporarily tighten the common rail bracket to the oil cooler assembly.

NOTE: The installation bolt and common rail assembly are tightened together.

2. Align the common rail assembly to the inlet cover.
3. Temporarily tighten the nut to the common rail assembly.

NOTE: The stud bolts of the inlet cover are tightened together.

4. Temporarily tighten the bolt to the common rail assembly.
5. Securely tighten the nut to the common rail assembly.

Tightening torque: **22 N·m (16 lb ft)**

NOTE: Refer to the tightening order in the diagram if the inlet cover is removed.

6. Securely tighten the bolt to the common rail assembly **(1)**.
Tightening torque: **19 N·m (14 lb ft)**
7. Connect the harness connector to the fuel pressure sensor **(2)**.
3. Common rail bracket

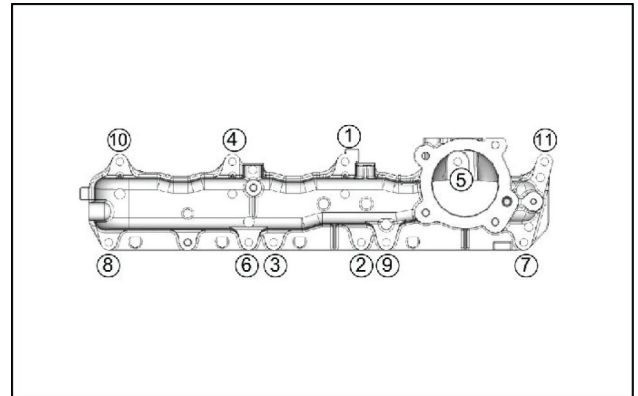

SML13CEX1693AA 3

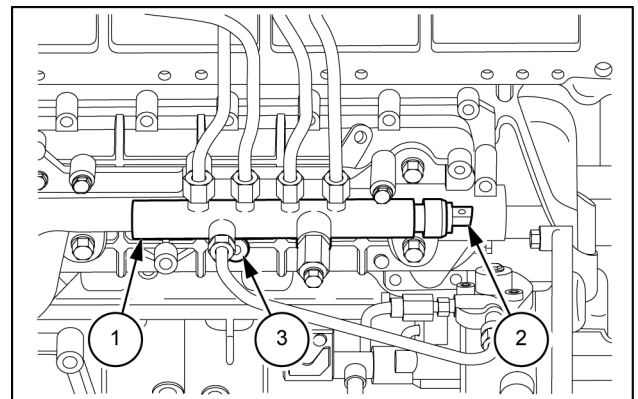

SML14CEX5651AB 4

Selective Catalytic Reduction (SCR) muffler and catalyst - Disassemble

Silicon controlled rectifier catalyst removal

1. Remove the silencer (5) from the SCR catalyst (3) and rear bracket (4).

NOTE: Remove the heat protector (6) and rear hanger.

2. Remove the SCR catalyst (3) from the front chamber (1) and front bracket (2).

NOTE: Remove the heat protector (6) and front hanger.

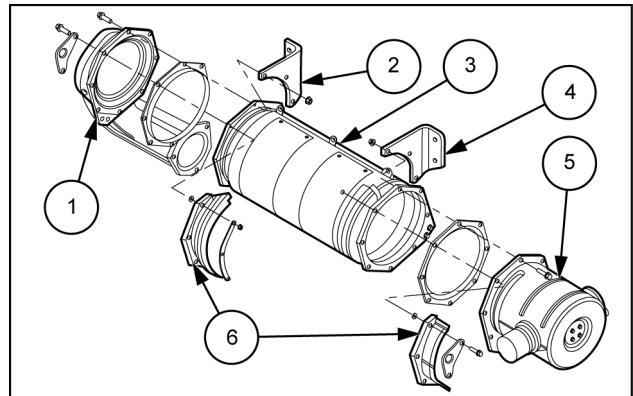

SMIL14CEX5699AB 1

Silicon controlled rectifier catalyst disassembly

1. Disconnect the front chamber from the mixing chamber.
2. Remove the mixing chamber from the oxidation catalyst assembly and bracket.

Engine cooling system - Component identification

The coolant system is the forced circulation system, and its main components are the water pump, thermostat and radiator.

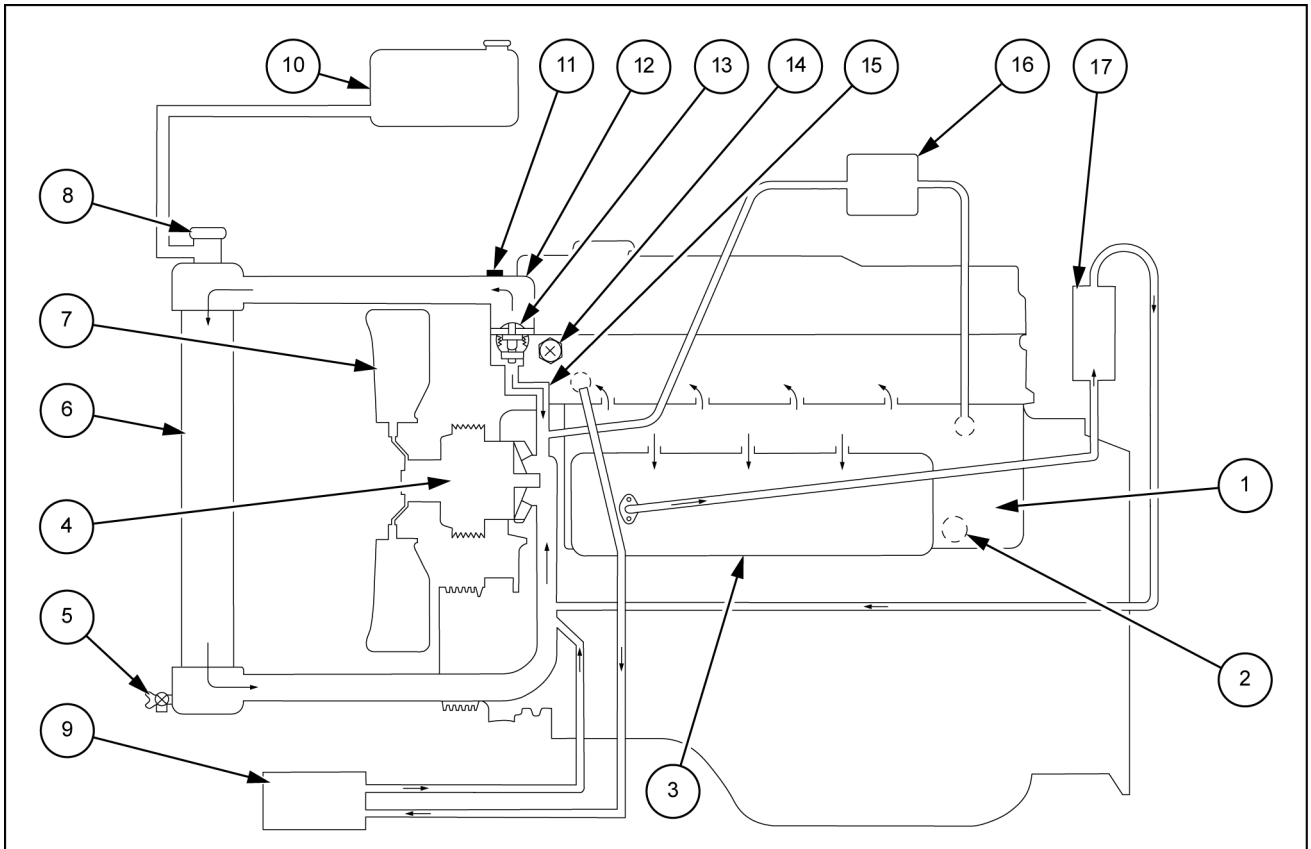

SMIL14CEX6875FB 1

- | | |
|-----------------|------------------------------|
| 1. Water jacket | 10. Radiator reserve tank |
| 2. Drain plug | 11. Air removal plug |
| 3. Oil cooler | 12. Water outlet pipe |
| 4. Water pump | 13. Thermostats, 2 units |
| 5. Drain cock | 14. Water temperature sensor |
| 6. Radiator | 15. Bypass route |
| 7. Cooling fan | 16. Turbocharger |
| 8. Radiator cap | 17. EGR cooler |
| 9. Heater core | |

Index

Engine - 10

Fan and drive - 414

Belt - Inspect	3
----------------------	---

Engine oil pump - Install

Oil pump assembly installation

1. Install the oil pump to the cylinder block.

NOTE: Use new gaskets.

Tightening torque: **31 N·m (22.9 lb ft)**.

Idle gear A installation

1. Align No. 1 cylinder to the compression top dead center.
2. Apply the engine oil to the idle gear A.
3. Install the idle gear A shaft to the idle gear A.
4. Align the idle gear A to alignment mark.

NOTE: Align the L mark on the crank gear with the O mark on the idle gear A.

5. Apply the engine oil to the bolt.

NOTE: Apply engine oil to the threaded portion and seat surface on the idle gear A installation bolt.

6. Install the idle gear A to the cylinder block.

Tightening torque: **133 N·m (98.10 lb ft)**

Contents

Hydraulic systems - 35

Hydraulic systems - 000

FUNCTIONAL DATA

Hydraulic systems	
Overview	4
Hydraulic systems	
Hydraulic schema - Travel circuit (*)	12
Hydraulic schema - Swing circuit (*)	23
Hydraulic schema - Boom circuit (*)	47
Hydraulic schema - Arm circuit (*)	67
Hydraulic schema - Bucket circuit (*)	91
Hydraulic schema - Negative control circuit (*)	103
Hydraulic schema - Other circuits (*)	107
Hydraulic schema - Option circuits (*)	127
Hydraulic schema - Travel circuit (*)	163
Hydraulic schema - Swing circuit (*)	175
Hydraulic schema - Boom circuit (*)	199
Hydraulic schema - Arm circuit (*)	219
Hydraulic schema - Bucket circuit (*)	241
Hydraulic schema - Negative control circuit (*)	253
Hydraulic schema - Other circuits (*)	257
Hydraulic schema - Option circuits (*)	277

SERVICE

Hydraulic systems	
Service instruction Table of standards (*)	313
Service instruction Table of standards (*)	316
Service instruction Measurement method	319
Pressure test	327
Pressure setting	343
Flow test	351
Bleed	357
Test	362

(*) See content for specific models

SWING PARKING CIRCUIT (BRAKE RELEASE)

When the engine is started and the swing lever is in neutral, the swing brake solenoid valve comes ON (**24 V** input), the pressure to the swing motor P port is cut, and the swing parking brake works.

When the lever operation raises the reading to higher than the specified pressure value at the pressure sensor in the swing pilot line, the output from the main computer to the swing brake solenoid valve goes OFF, the swing motor P port pressure rises, the swing parking brake is released, and swing becomes possible. As an example, this section explains the right swing operation.

By carrying out the right swing operation on the remote control valve, the pilot pressure oil is fed to the control valve pa3 port via the cushion valve and switches the swing spool to the right swing side.

At the same time, the main computer detects the swing pilot pressure sensor signal, judges that there is a swing operation, the electrical signal output from the main computer goes OFF, and switches the swing brake solenoid valve. The pilot pressure oil is fed to the swing motor P port from the swing brake solenoid valve C2 port to release the swing parking brake.

The discharge oil from hydraulic pump A1 enters the control valve P1 port and is fed from the parallel oil path to the swing spool.

Switching the spool lets the oil flow into the swing motor A port and the right swing operation is carried out. The pressure oil from the swing motor B port goes through the swing spool and returns to the hydraulic tank. When this is followed by an attachment operation, the pilot pressure is detected by respective pressure sensors and the swing parking brake continues to be released.

After the swing operation ends, if about **5 s.** pass with no upper operation, the swing brake solenoid valve output from the main computer comes ON and the swing parking brake works again.

After the swing ends, if this is followed by an upper operation, when about **1 s.** passes after the end of the upper operation, the swing parking brake works again.

For upper independent operation, the swing parking brake is also released. When about **1 s.** passes after the end of the upper operation, the swing parking brake works again.

Key switch	Swing pilot pressure sensor	Upper pilot pressure sensor	Swing brake solenoid valve	Swing motor mechanical brake
OFF	OFF	OFF	OFF	ON
ON	OFF	OFF	ON	ON
ON	Higher than specified pressure	OFF	OFF	OFF
ON	OFF	Higher than specified pressure	OFF	OFF
ON	Higher than specified pressure	Higher than specified pressure	OFF	OFF

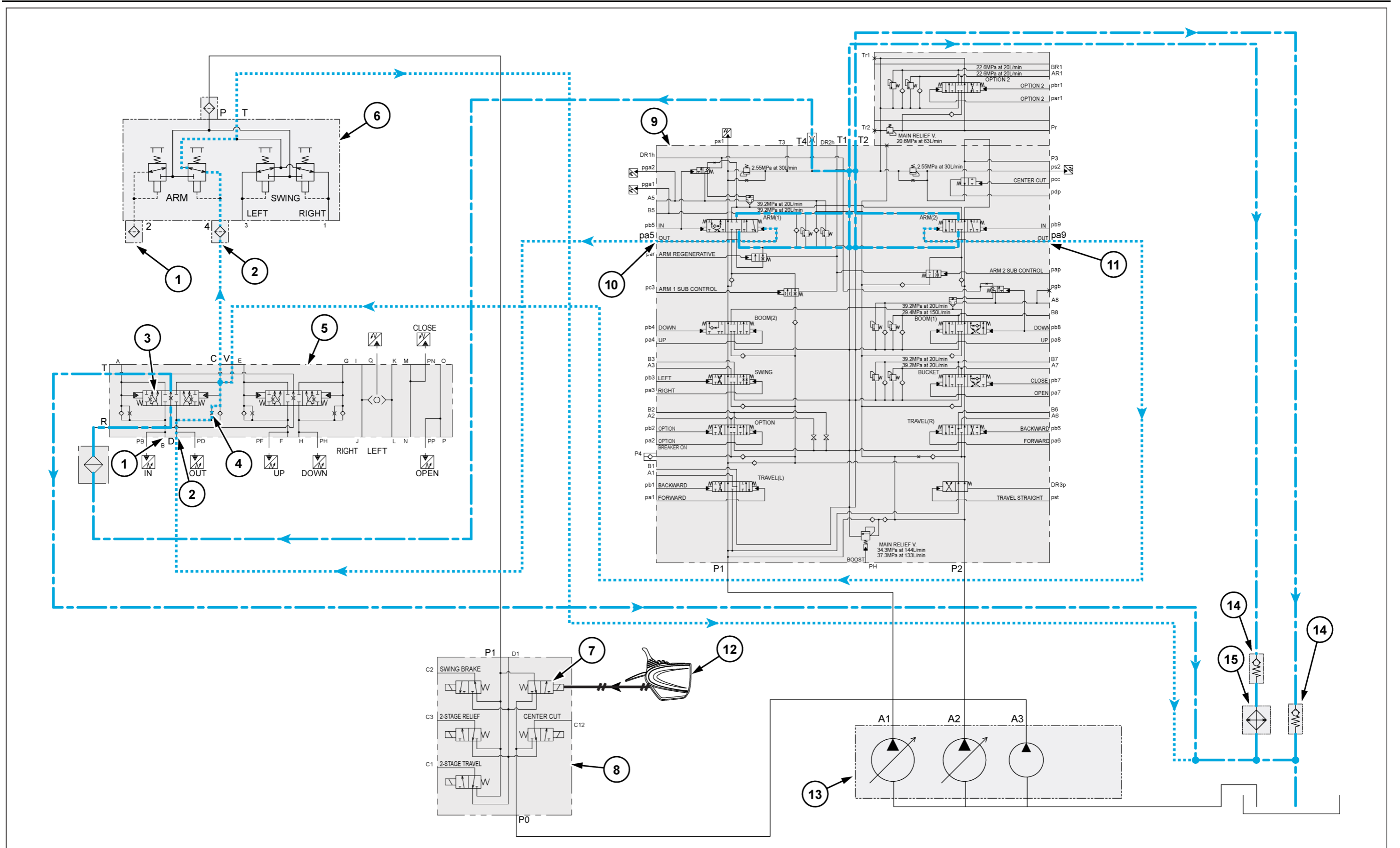

SM115CEX2889JB 2

SWING PARKING CIRCUIT (LEVER IN NEUTRAL)

When the key is switched ON, the swing brake solenoid valve is switched by the electrical signal from the main computer.

The swing motor P port oil goes from the 5 stack solenoid valve C2 port through the swing brake solenoid, and returns to the hydraulic tank to hold the swing parking brake.

Switching the boom spool lets the oil flow into the boom cylinder rod side and the boom-up operation is carried out.
Continuous arm operations (skeleton operation)
When judging the skeleton operation, the opening of the arm (1) parallel spool opens.

- The continuous arm open/close operations prevent hunting of the arm (1) parallel spool.

CUSHION CIRCUIT (WHEN ARM-OUT OPERATION STOPPED)

When the remote control valve arm-out operation is returned to neutral, the oil pushed out from the control valve pa5 and pa9 ports flows to the cushion valve D port through the cushion orifice and returns from the remote control valve to the hydraulic oil tank.

Through this orifice, the arm spool moves to the neutral position without returning sharply, so the cushioning is improved.

— Pressure line
- - Tank line
- - - Pilot pressure line

..... Pilot tank line
— Electric line

- | | |
|------------------------------|--|
| 1. Control valve | 9. Proportional switch |
| 2. Hydraulic fork | 10. Option pilot pressure sensor |
| 3. Monitor display | 11. Check valve |
| 4. Main computer | 12. Oil cooler |
| 5. Lever lock | 13. ATT select switch |
| 6. 5 stack solenoid valve | 14. P1 pressure sensor |
| 7. Console lever lock switch | 15. 2 stack reducing valve |
| 8. Hydraulic pump | 16. P1 flow control proportional valve |

Install the pressure gauge (2) to the adapter (1) and fix them.

Pressure gauge Port size: G1/4 for **60 MPa (8703 psi)**

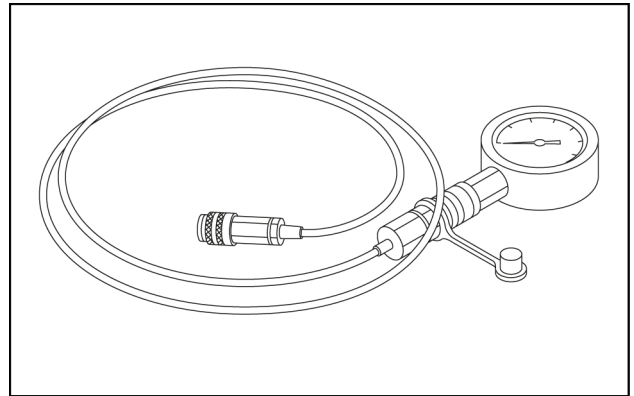

SMIL14CEX2084AA 18

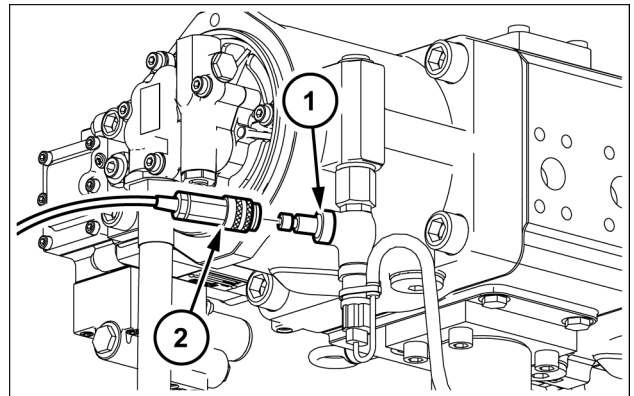

SMIL14CEX5081AB 19

A. Attachment pressure measurement

Example: Arm-out pressure measurement
Perform measurement according to the following operation.

Engine speed	1800 RPM
Work mode	SP mode
Lever operation	arm-out relief
Oil temperature	45 - 55 °C (113 - 131 °F)
Measuring port	1 pumps: P1 port 2 pump: P2 port
Set pressure	Pressure boost: 37.3 MPa (5410 psi) Standard: 34.3 MPa (5410 psi)

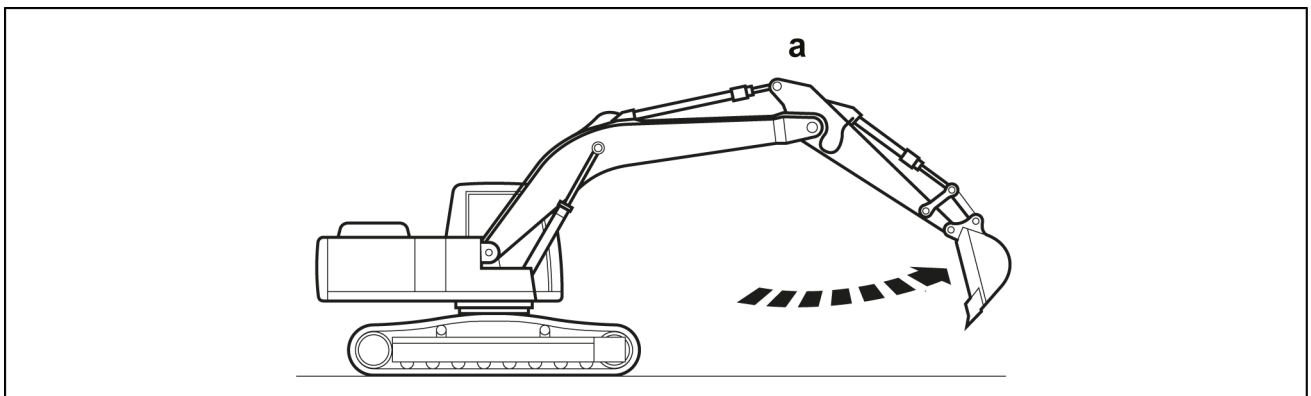

SMIL14CEX2086EA 20

a. Arm-out relief

10. Remove the 9 bolts (1) with a wrench [19 mm] to remove the cover (2) and the stay (3).

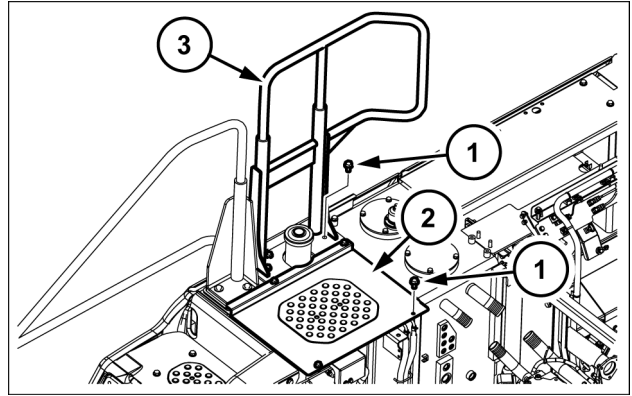

SMIL14CEX5104AB 8

11. Remove the side cover (1).

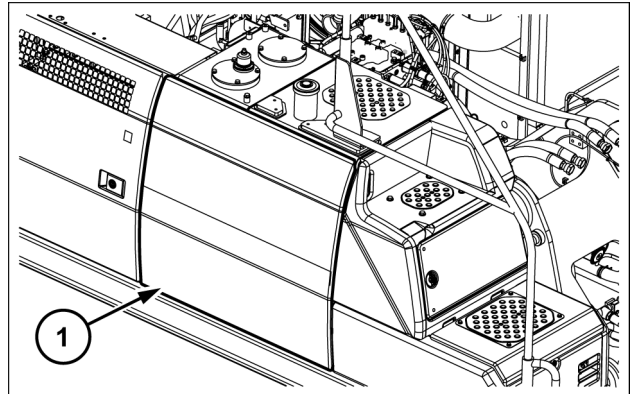

SMIL14CEX5105AB 9

12. Remove the 4 bolts (1) and the 4 spacers (2) at bottom of the hydraulic tank with a wrench [24 mm].
- Do not lose a shim which may be inserted between the reservoir and the frame in order to adjust height depending on system.
 - Also, note inserted section and quantity.
 - Bolt tightening torque: **232.4 - 276.0 N·m (171.4 - 203.6 lb ft)**

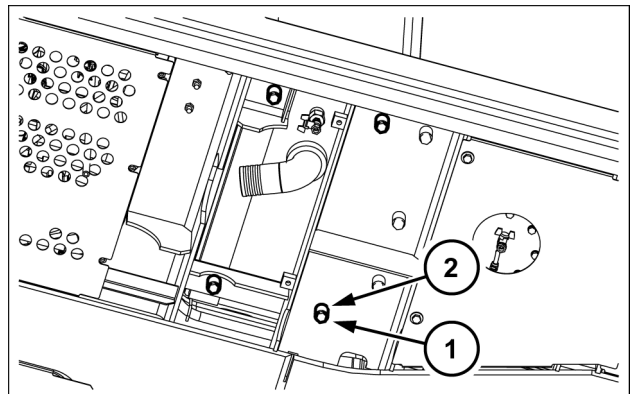

SMIL14CEX5106AB 10

13. Remove the bolt (1) and then attach the 2 eyebolts (M12) on top of the hydraulic tank.
- Tighten up the eyebolt all the way and then loosen it for a half turn.
 - Make sure not to interfere the level gauge with anything around while lifting.

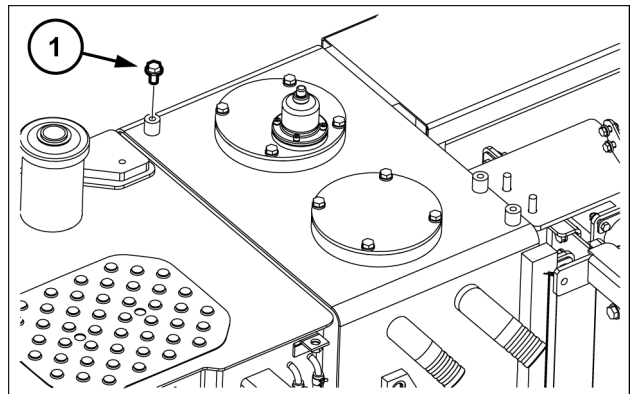

SMIL14CEX5107AB 11

8. Install the shoe plate **(211)** to the swash plate **(212)**. Then fit in the tilting pin **(531)** to the tilting bushing **(214)** of the servo piston **(532)** and properly attach the swash plate and the shoe plate to the swash plate support board **(251)** while tilting the support board as shown in the figure.

- Check that the swash plate moves smoothly with finger tips of both hands.
- Applying grease to the swash plate, the swash plate support board, and the sliding section improves workability of the drive shaft attachment.
- Be careful not to damage the shoe plate sliding surface.

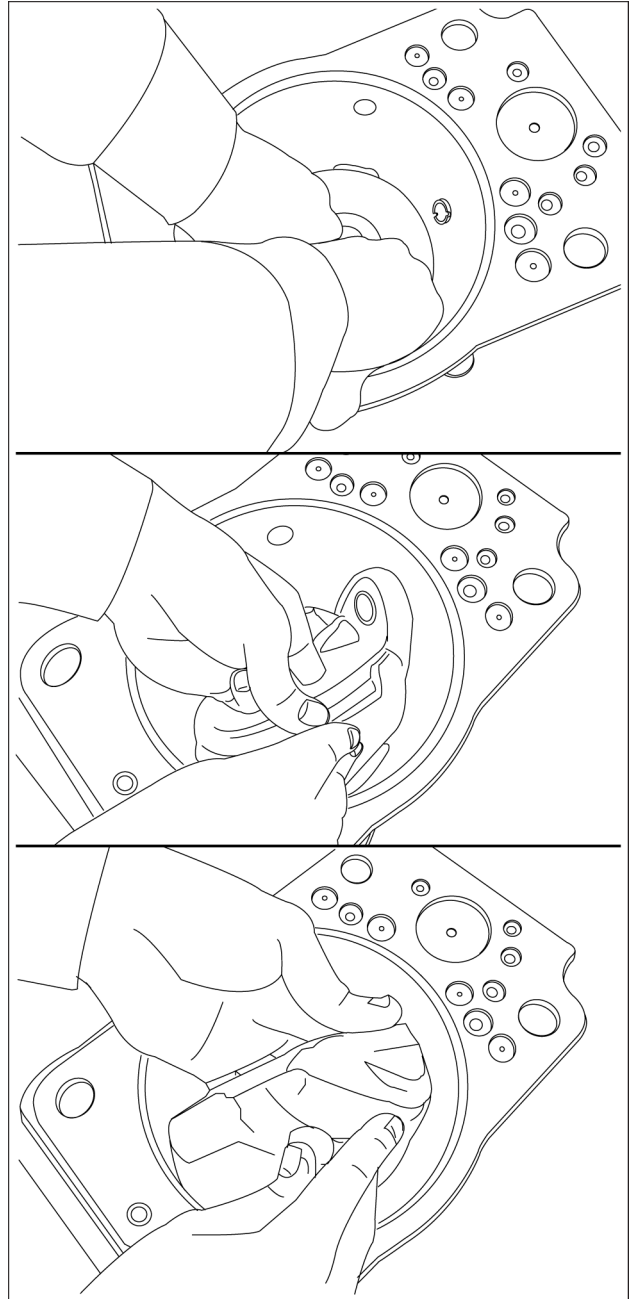

SMIL14CEX5132CA 3

9. Attach the drive shafts **(111)** and **(113)**, of which the cylinder roller bearing **(123)**, the bearing spacer **(127)**, and the stop ring **(824)** are set, to the pump casings **(271)** and **(272)**.

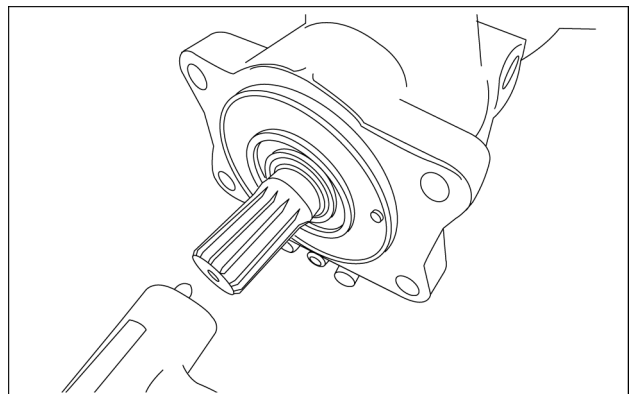

SMIL14CEX6424AA 4

Contents

Hydraulic systems - 35

Main control valve - 359

FUNCTIONAL DATA

Main control valve	
Overview	3
Dynamic description	6
Stacked control valves	
Component diagram	37

SERVICE

Main control valve	
Prepare	45
Remove	47
Install	55
Stacked control valves	
Disassemble	56
Cleaning	62
Inspect	63
Assemble	64
Main pressure control valve	
Disassemble	70
Assemble	73
Adjust	77
Install	79
Inspect	80

DIAGNOSTIC

Stacked control valves	
Troubleshooting	81
Main pressure control valve	
Troubleshooting	82

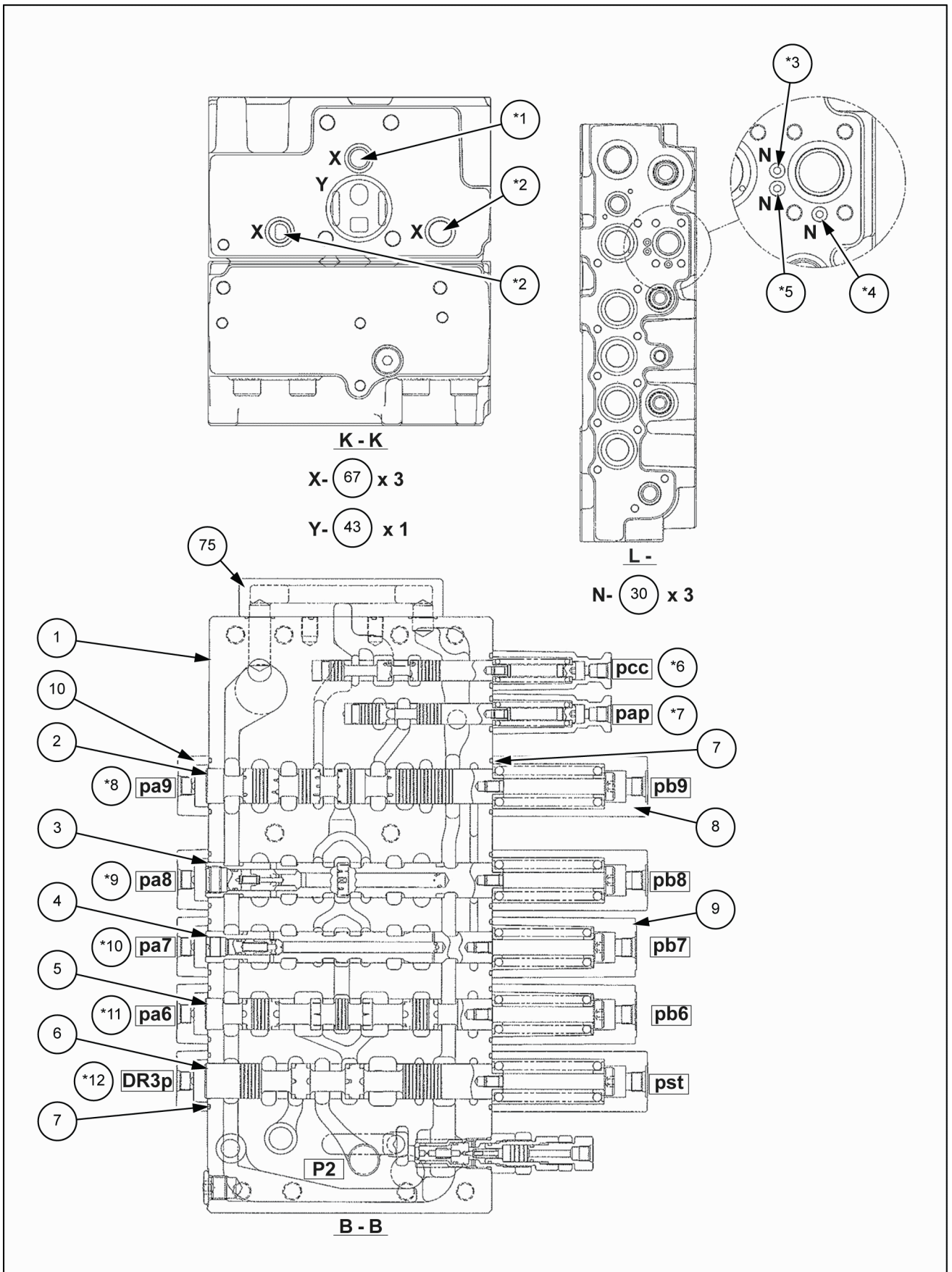

SMIL14CEX3645HB 3

- *1. Parallel
- *2. Reservoir
- *3. Drain

- *7. Arm 2 semi-parallel
- *8. Arm 2 in/out
- *9. Boom 1 down/up

Thoroughly clean the relief installation section of the valve housing, install the relief valve, and then tighten the plug **(1)**.

- Tightening torque: **59 - 69 N·m (43.52 - 50.89 lb ft)**

Adjust pressure referring to the paragraph for adjustment of the relief valve when the adjuster kit is disassembled.

Assemble	58
Install	60

DIAGNOSTIC

Hand control	
Troubleshooting	61

Hydraulic hand control - Install – Right side

1. Clean all the parts with a rag.

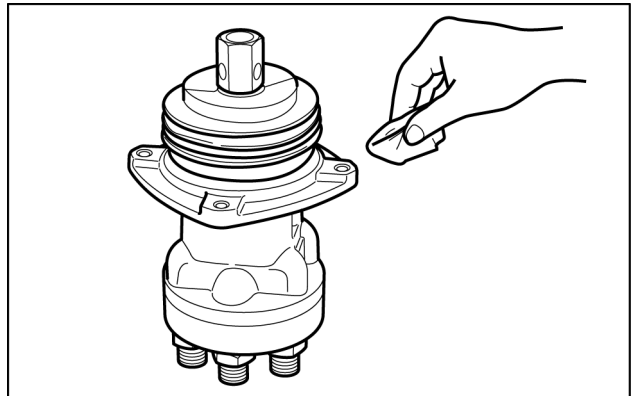

SMIL14CEX1408AA 1

2. Install the joystick remote control valve (1).

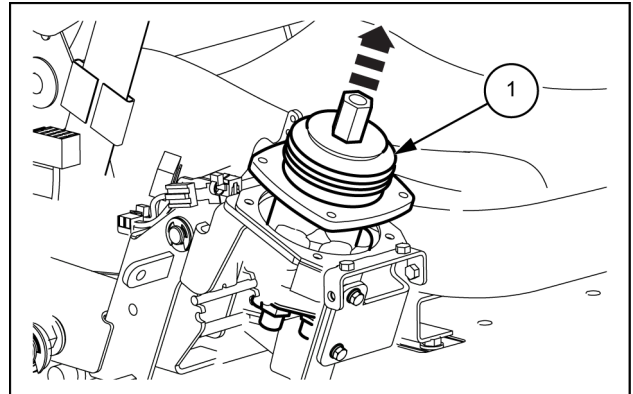

SMIL14CEX1425AB 2

3. Use a hexagon wrench [5 mm] install the 3 bolts (1) and 3 washers (2).

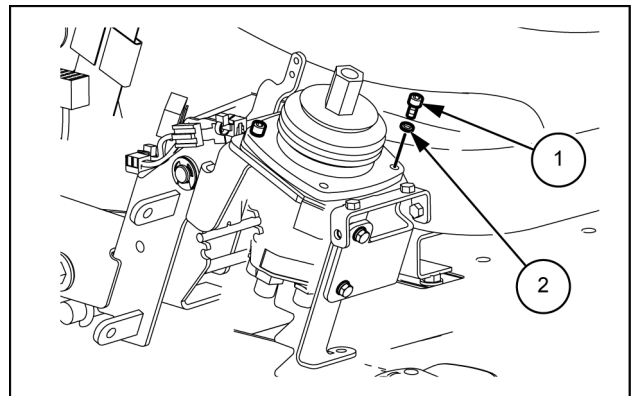

SMIL14CEX1424AB 3

4. Use a wrench [22 mm] to install the 6 hoses (1).

- P port
Hose adapter tightening torque: **25.4 - 31.4 N·m (18.734 - 23.159 lb ft)**
Hydraulic hose tightening torque: **44 - 54 N·m (32.45 - 39.83 lb ft)**
- T port, 1 - 4 ports
Hose adapter, hydraulic hose tightening torque: **41 - 54 N·m (30.24 - 39.83 lb ft)**

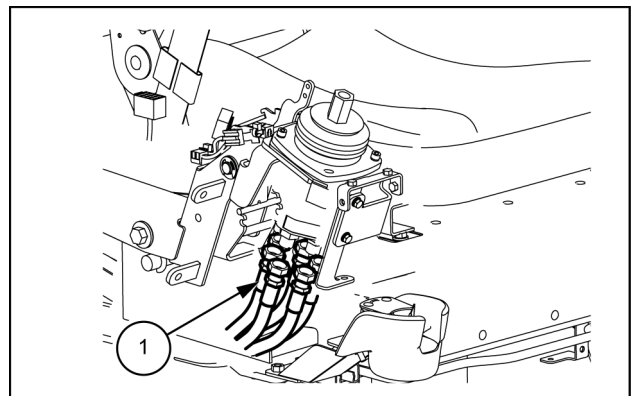

SMIL14CEX1423AB 4

9. Pull up the travel remote control valve **(1)** into the cab to remove the travel remote control valve.

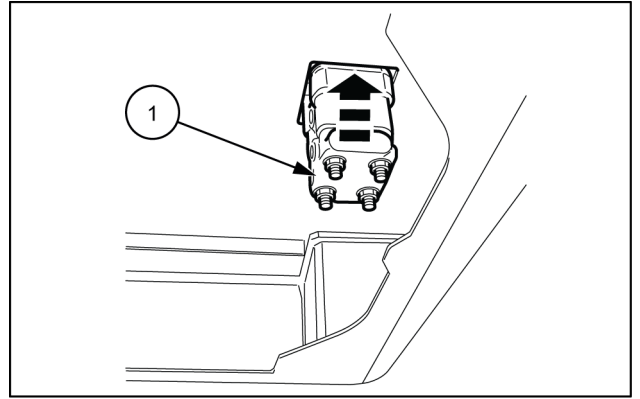

SMIL14CEX1534AB 9

Brake piston assembly (9)

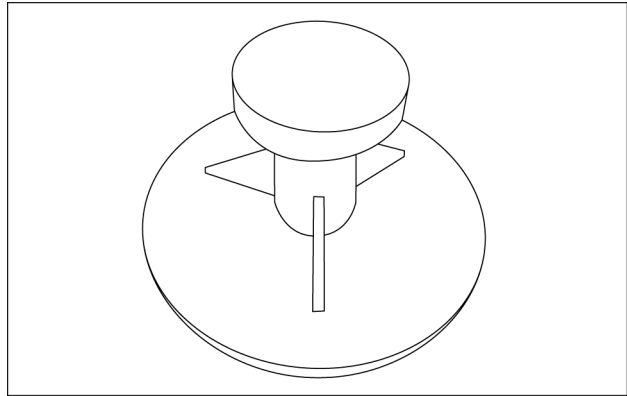

SMIL15CEX2060AA 12

Spring cylinder (23) assembly press

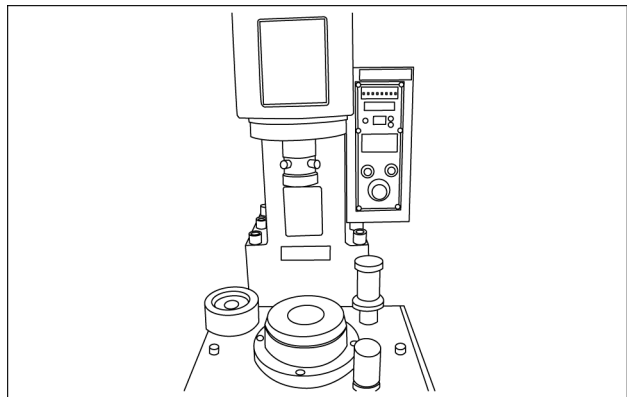

SMIL15CEX2061AA 13

12. Remove the piston assembly **(6)** and plate set **(5)** from the cylinder block assembly.

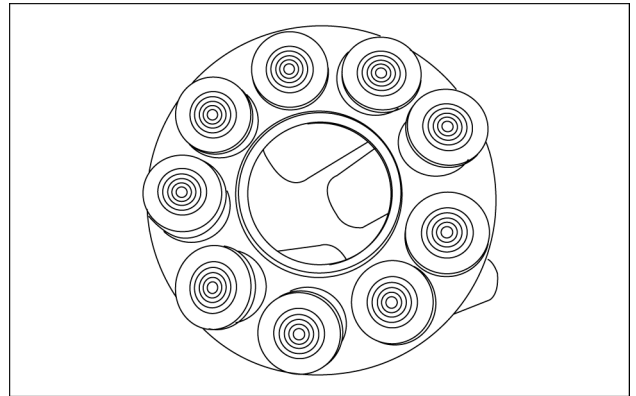

SMIL15CEX2078AA 17

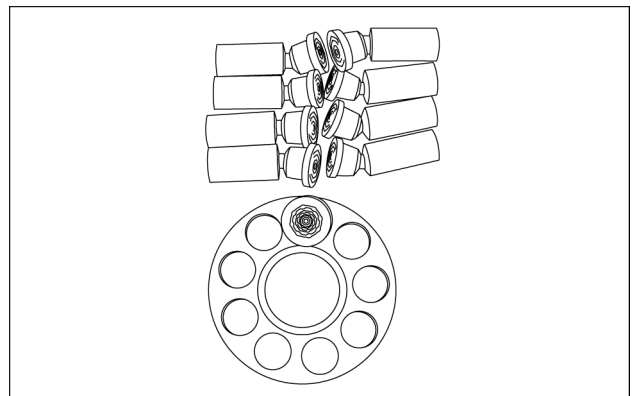

SMIL15CEX2079AA 18

13. Remove the ball guide **(28)**, spacer **(27)** and needle roller **(26)** from the cylinder block **(25)**.

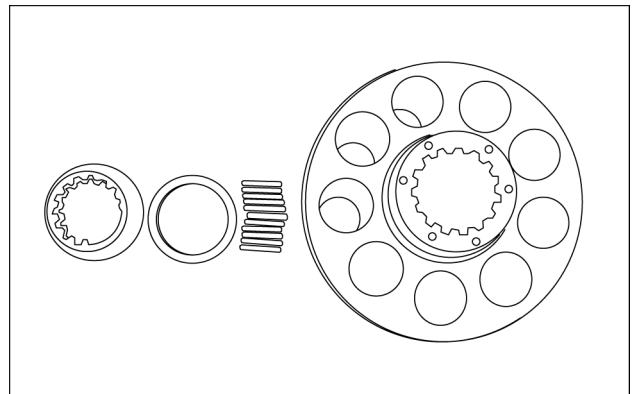

SMIL15CEX2080AA 19

14. Press the cylinder block **(26)** by spring cylinder **(23)** assembly JIG tool.

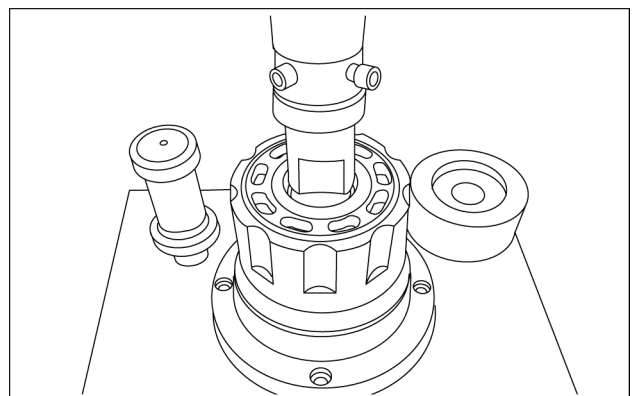

SMIL15CEX2081AA 20

Hydraulic systems - Hydraulic travel system

Code	Jig name	Code	Jig name
1	Pulley puller	5	Rod 1
2	Bearing press-fit jig 1	6	Angular bearing press-fit jig
3	Bearing press-fit jig 2	7	Shim thickness adjustment jig
4	Floating seal installation jig	8	Rod 2
a	Puller	ac	Ø 91 mm (3.583 in)
b	Guide shaft	ad	30 mm (1.181 in)
c	Hammer	ae	34 mm (1.339 in)
d	Stopper nuts [M8x1.25]	af	Ø 36 mm (1.417 in)
e	Guide A (flange and housing : material DURACON)	ag	Ø 73 mm (2.874 in)
f	Guide B (flange)	ah	4.9 - 5.1 mm (0.1929 - 0.2008 in)
g	Guide C (housing)	ai	24.9 - 25.1 mm (0.9803 - 0.9882 in)
h	Press-fit auxiliary jig (flange)	aj	11.2 - 11.5 mm (0.4409 - 0.4528 in)
i	M8 thread depth	ak	14 - 16 °
j	Surface knurling processing	al	11.5 mm (0.4528 in)
k	Including the assembly diagram	am	Ø 370 mm (14.567 in)
l	32 mm (1.260 in)	an	Ø 296 mm (11.654 in)
m	2 mm (0.079 in)	ao	Ø 328.9 - 329.1 mm (12.9488 - 12.9567 in)
n	20 mm (0.787 in)	ap	Ø 331.5 - 331.6 mm (13.0512 - 13.0551 in)
o	Ø 24 mm (0.945 in)	aq	Ø 331.3 - 331.4 mm (13.0433 - 13.0472 in)
p	Ø 33 mm (1.299 in)	ar	C 0.5 mm (0.0197 in)
q	C 1 mm (0.039 in)	as	Radius 0.5 mm (0.0197 in)
r	60 mm (2.362 in)	at	Ø 345.2 - 345.3 mm (13.5906 - 13.5945 in)
s	10 mm (0.394 in)	au	Ø 332.3 - 332.4 mm (13.0827 - 13.0866 in)
t	80 mm (3.150 in)	av	Ø 345.5 - 345.7 mm (13.6024 - 13.6102 in)
u	250 mm (9.843 in)	aw	Ø 337.0 - 337.1 mm (13.2677 - 13.2717 in)
v	Ø 9 mm (0.354 in)	ax	Ø 332.2 - 332.4 mm (13.0787 - 13.0866 in)
w	Ø 70 mm (2.756 in)	ay	Ø 344.5 - 344.6 mm (13.5630 - 13.5669 in)
x	Ø 80 mm (3.150 in)	az	Radius 0.1 - 0.2 mm (0.0039 - 0.0079 in)
y	25 mm (0.984 in)	ba	Radius 1 mm (0.039 in)
z	Ø 8 mm (0.315 in)	bb	Ø 280 mm (11.024 in)
aa	Ø 100 mm (3.937 in)	bc	Ø 294 mm (11.575 in)
ab	Ø 51 mm (2.008 in)		

Travel motor - Disassemble

Perform disassembly by observing all the precautions and following the procedure indicated below.

Removal of cap assembly

Secure the motor on top of the stable work platform, loosen the 8 hexagon socket head bolts (1-2-6-4), and remove the 2 cap assemblies (1-2-6).

Next, remove the springs (1-2-4) and spring seats (1-2-3).

NOTE: The cap assemblies are pushed out by the spring. For this reason, observe the following precautions when working.

- Loosen the hexagon socket head bolts evenly.
- Loosen the hexagon socket head bolts while pressing down the cap assemblies.

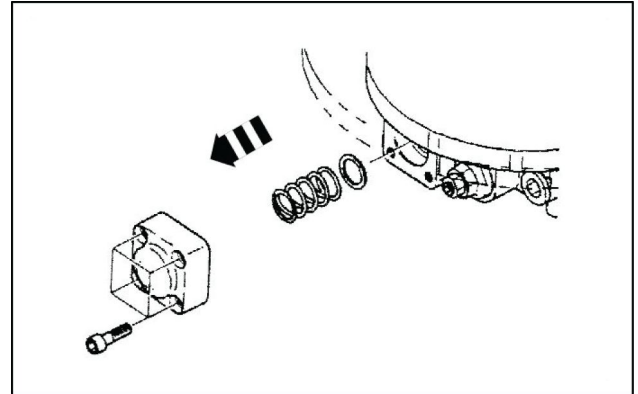

LPIL12CX01337AA 1

Removal of plunger assembly

Lightly press the end of the plunger assembly (1-2-2) to partially eject the plunger assembly from the base plate (1-2-1).

Next, hold the end of the plunger assembly by hand and remove the plunger assembly from the base plate while rotating it.

NOTICE: The plunger assembly and base plate are fit together with a very small gap. For this reason, observe the following precautions when working.

- Do not try to force out the plunger assembly if it becomes stuck when being removed. If it is forced out, this could scratch the inner diameter surface of the base plate hole or the outer diameter surface of the plunger assembly. If the plunger assembly becomes stuck, lightly hit the end surface of it with a plastic hammer to insert it once into the base plate. After this, check that the plunger assembly moves smoothly and remove it again while rotating it.
- Do not perform disassembly of the plunger assembly if it is not necessary. Disassembly can cause scratching on the outside diameter surface of the plunger assembly. When disassembly is necessary, contact our company.

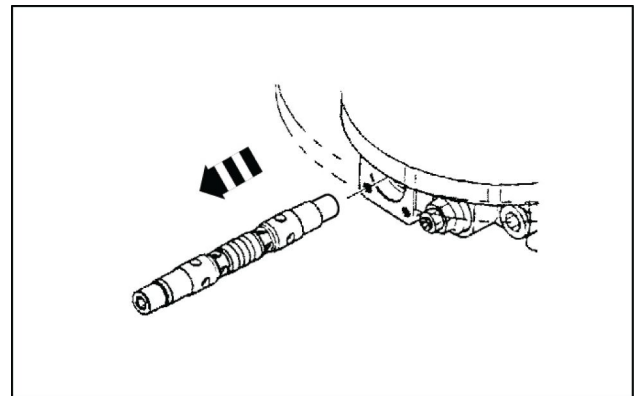

LPIL12CX01338AA 2

Removal of relief valve assembly

Loosen the plug (1-2-7-6) to remove the relief valve assemblies (1-2-7).

At this time, each poppet seat (1-2-7-3) remains in the base plate (1-2-1). The relief valve assemblies are at a set pressure. The motor driving force and braking force are both determined by this set pressure. For this reason, do not perform the following actions.

- Loosen the nut (1-2-7-16), and do not tamper with the set screw (1-2-7-15). If this part is tampered with, the set pressure of the relief valve will change and the machine will no longer display prescribed capabilities.
- Do not perform disassembly of the relief valve assemblies. The set pressure will change and the machine will no longer display prescribed capabilities.

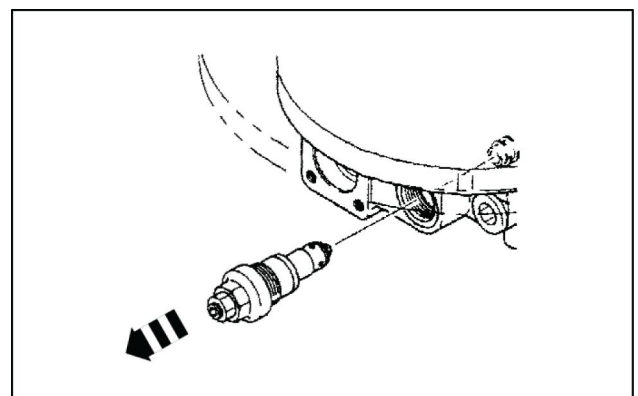

LPIL12CX01339AA 3

Travel motor - Install

1. Install the travel motor to the lower frame as shown in the figure.
 - Pay attention to installation angle.

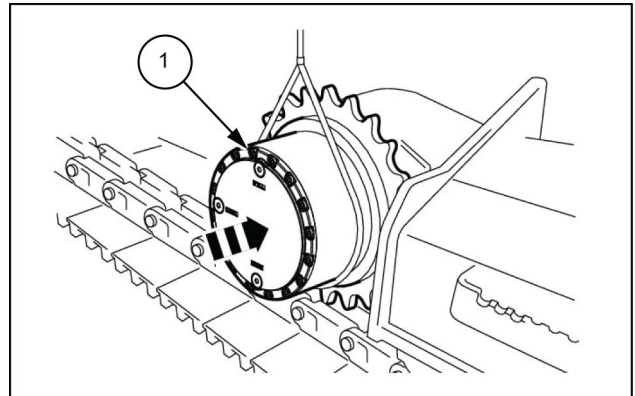

LPIL12CX01325AB 1

2. Apply **LOCTITE® 262™** to the thread area of all the 28 mounting bolts (**2**). Tighten them top to bottom alternately so as to apply even diagonal tightening force with specified torque with a wrench [**24 mm**]. Tightening torque **M16: 267 - 312 N·m (196.93 - 230.12 lb ft)**.

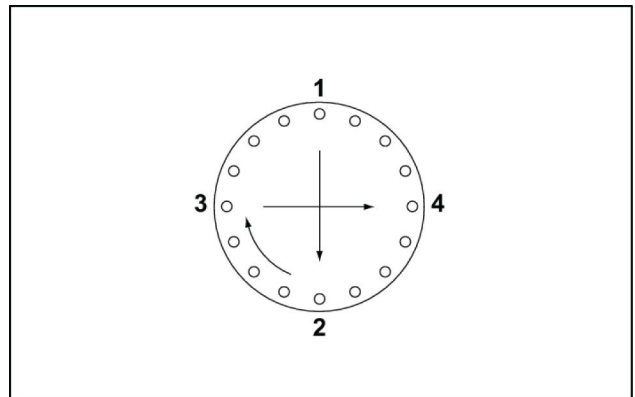

LPIL12CX01326AB 2

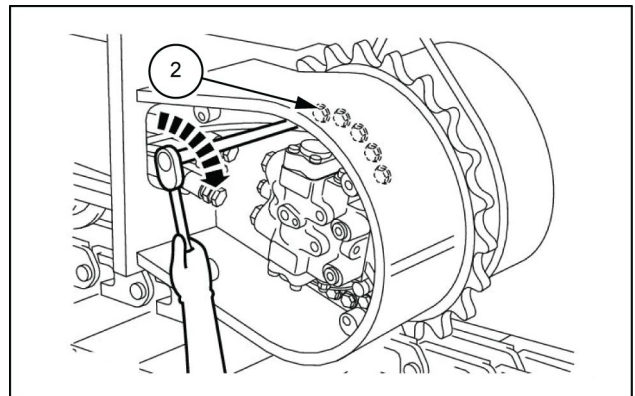

LPIL12CX01327AB 3

Prepare	55
Remove	56
Install	58

DIAGNOSTIC

Boom cylinder	
Troubleshooting	59

Pull out the piston rod

1. Check that the line caps are removed.
2. Put the oil pan at the retraction side (cylinder head side) port.
3. With the piston rod pulled out all the way, slowly pull out the cylinder head and remove it.
4. Pull out the piston rod together with the cylinder head and place them on crossties.

⚠ CAUTION:

When assembling and disassembling with the cylinder secured vertically, work paying particular attention to the following points.

In the work of removing the piston rod, the cylinder head may come out of the cylinder tube ahead of the piston due to friction with the packing, creating a condition in which there is space between the cylinder head and the piston.

If the work is done in that state, the cylinder head may suddenly slip out and injure the operator.

Always work with the cylinder head touching the piston.

- a. Beware of falling

⚠ CAUTION:

When assembling and disassembling with the cylinder secured horizontally, work paying particular attention to the following points.

In the work of removing the piston rod, there is a danger of the piston rod falling and damaging parts right after it is removed.

Work carefully while holding the rod horizontal and in contact with the crossties.

- a. Crosstie
b. Working in the horizontal state
c. Beware of falling

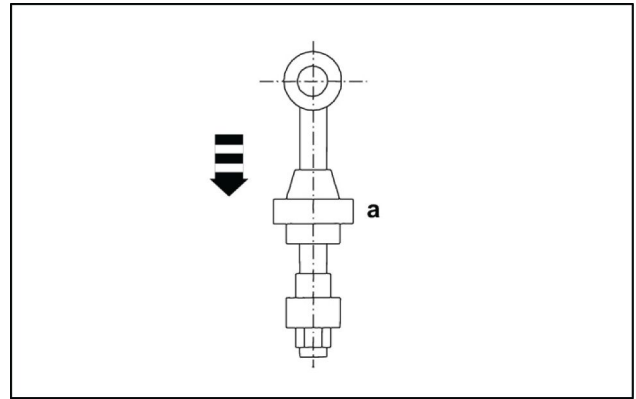

LPIL12CX02053AA 2

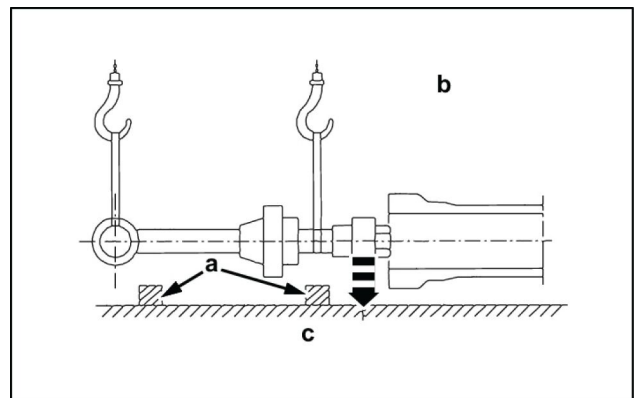

LPIL12CX02054AA 3

Fasten the piston rod

Use the rod head bolt width or pin hole to set up a rotation stopper.

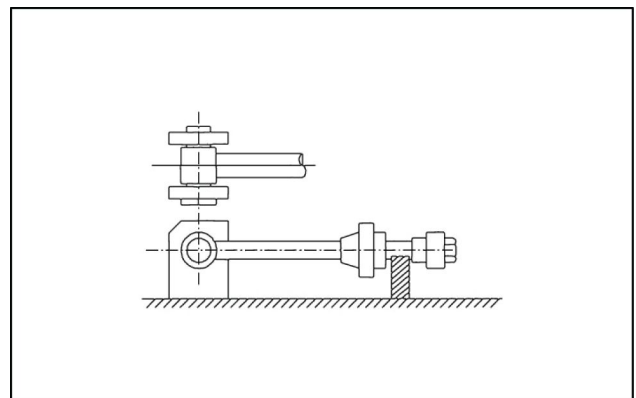

LPIL12CX02055AA 4

13. Push out the pin (1) with a hammer (2) and a striking rod (3).

- If it is hard to pull out the pin, load is applied to the pin.
- When pulling out the pin, be careful not to damage the attached dust seal.

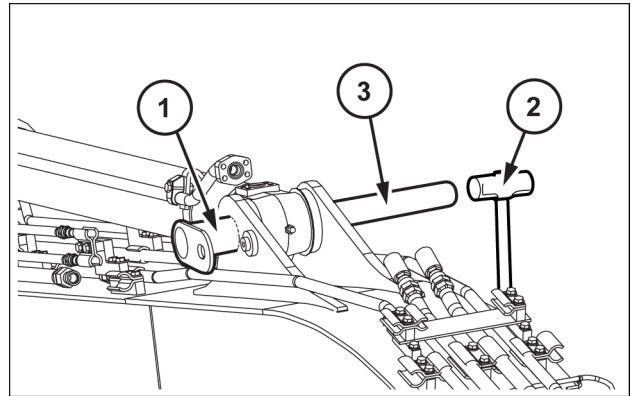

SMIL15CEX2910AB 13

14. Place the arm cylinder (1) on the crosstie.

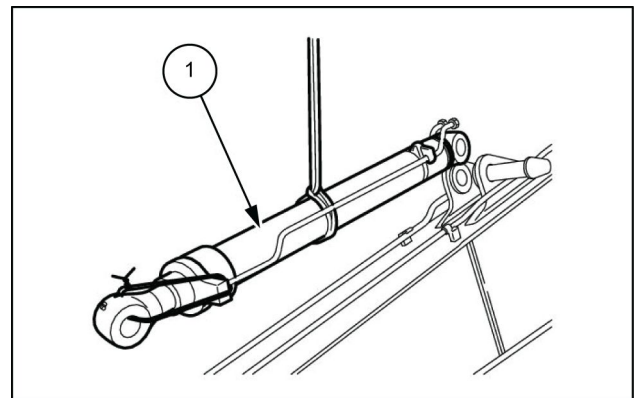

LPIL12CX01559AB 14

NOTE: To disassemble the cylinder, see **Boom cylinder - Disassemble (35.736)**.
To assemble the cylinder, see **Boom cylinder - Assemble (35.736)**.

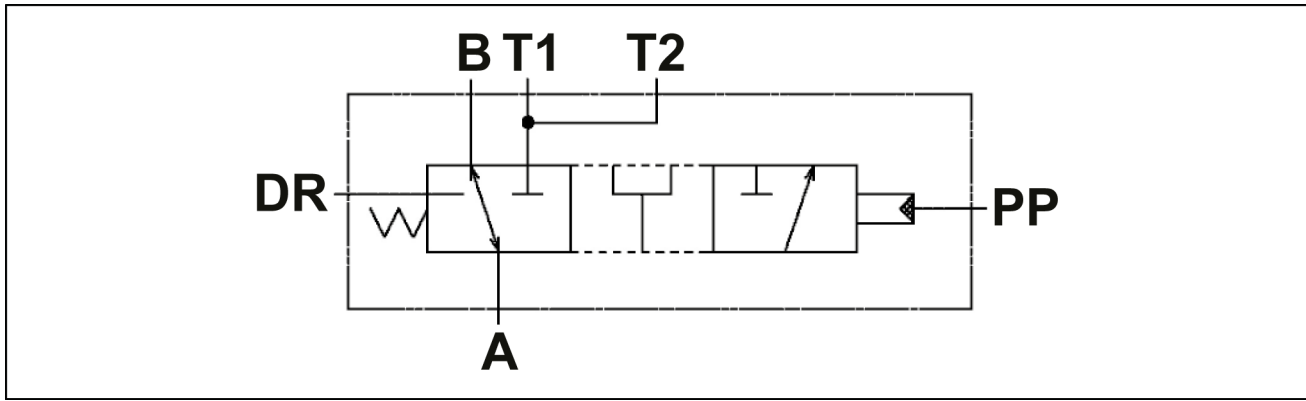

SML14CEX3867EA 2

Circuit diagram

- | | |
|---------------|------------------------------|
| 1. Cover | 7. Spring |
| 2. Name plate | 8. Hexagon socket head bolt |
| 3. Spool | 9. Hexagon socket head bolt |
| 4. Spring | 10. Hexagon socket head bolt |
| 5. Body | 11. Rivet screw |
| 6. Cover | 12. O-ring |

Track chain - Install

1. Raise the lower side frame by about **20 cm (7.9 in)**.
Lift the track shoe **(1)**, and align it with the sprocket **(2)**.
Be careful not to confuse front and rear of the track shoe.

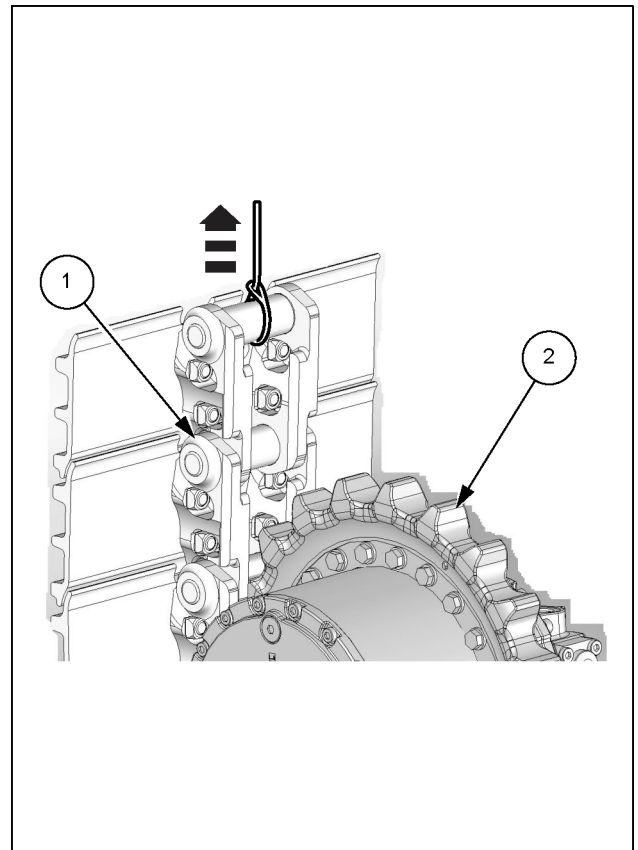

SMIL14CEX2128BB 1

2. Operate the travel lever slowly toward the forward position to send the track shoe toward the take-up roller as shown in the figure.
While passing the upper roller on the way, use a crow-bar etc. to raise the track shoe. After sending the shoes to the position A in the figure, lower the lower side frame.

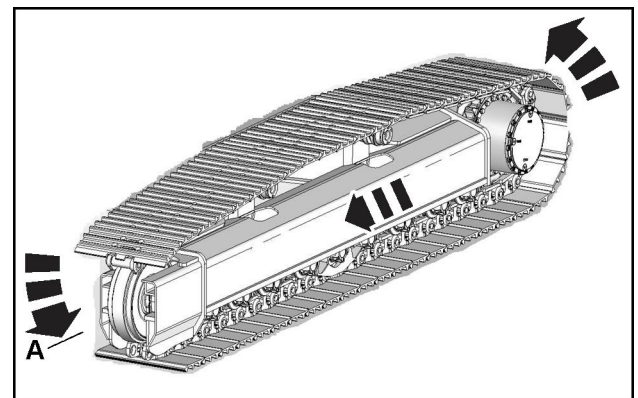

SMIL14CEX2129AA 2

3. Wrap the end of the track shoe **(1)** on the take-up roller **(2)**.
Place wood planks **(3)** to raise the lower link, and align the positions for the master pin.

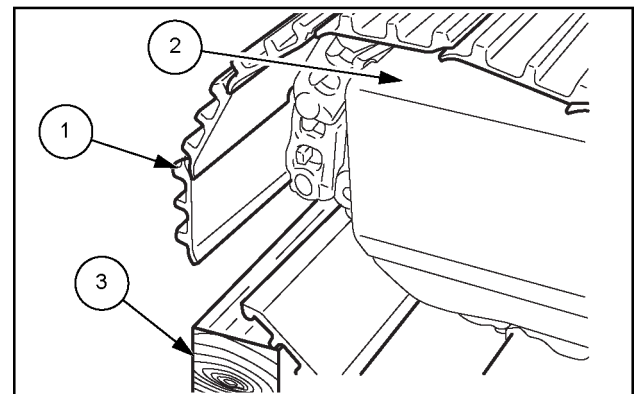

SMIL14CEX2130AB 3

CLICK HERE TO **DOWNLOAD** THE COMPLETE MANUAL

- Thank you very much for reading the preview of the manual.
- You can download the complete manual from: www.heydownloads.com by clicking the link below



- Please note: If there is no response to CLICKING the link, please download this PDF first and then click on it.

CLICK HERE TO **DOWNLOAD** THE COMPLETE MANUAL

11. Install the opposite side hub (1) on the roller (2) and fasten with the hub pin (3).

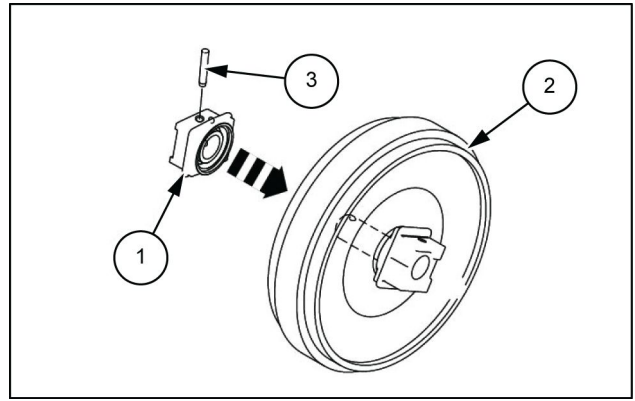

LPIL12CX01193AB 11

12. Inject compressed air [**0.2 MPa (29 psi)**] from the oil fill port and immerse in water to check that there are no leaks.

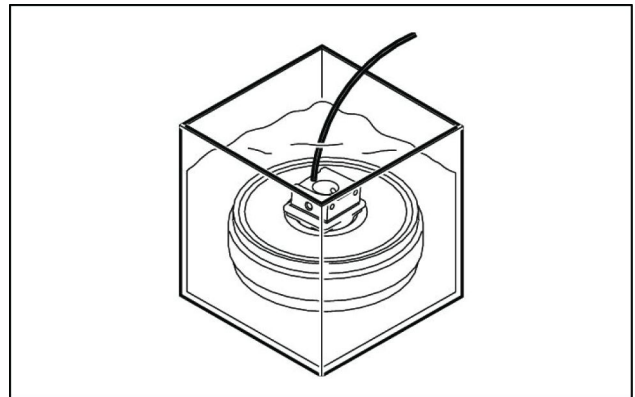

LPIL12CX01194AA 12

13. Fill engine oil (**150 cm³ (9.15 in³)**) into the roller main unit.
- The roller main unit can be very unstable, so be careful in securing it.

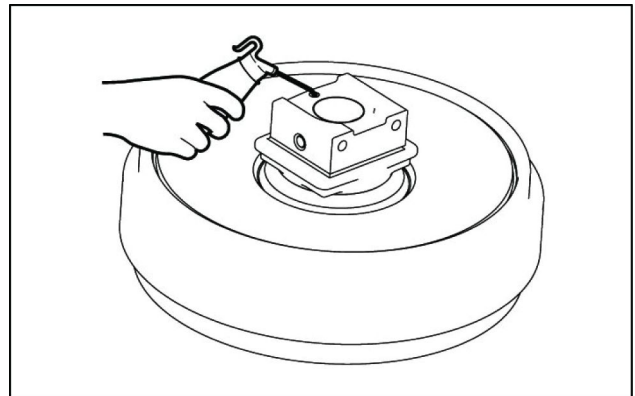

LPIL12CX01195AA 13

14. After filling the oil, use a hexagon wrench [**6 mm**] (2) to tighten the plug (1) with the nylon seal applied.
- To reuse a plug, wrap it with seal tape.

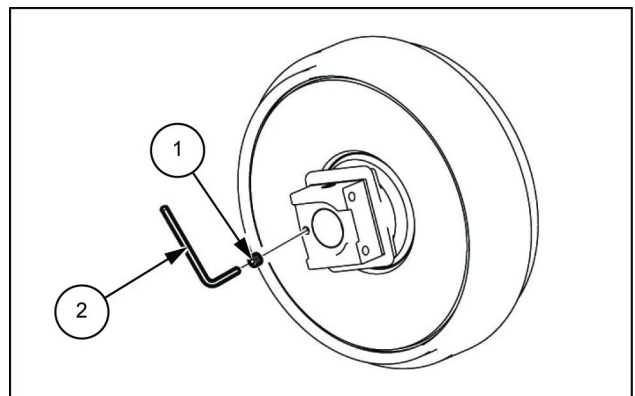

LPIL12CX01196AB 14

5. Insert the floating seal (3) into the roller (1) and bracket (2).
Use jig C (4) to press it into position.

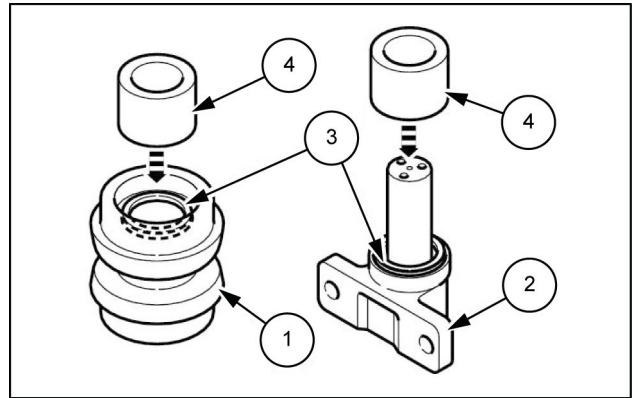

LPIL12CX01262AB 5

6. Use a special fiber cloth to wipe the surfaces of the floating seals so as to increase adhesion and prevent dust from entering.

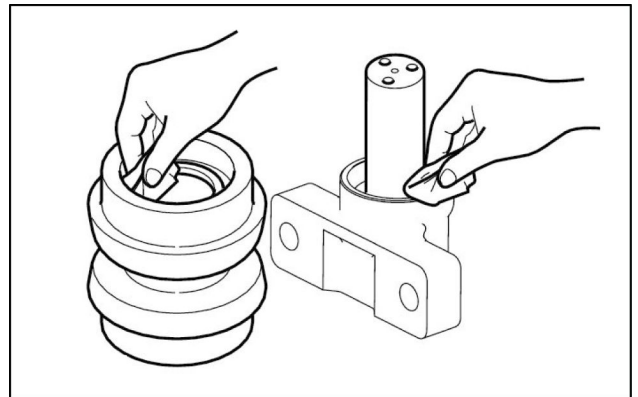

LPIL12CX01263AA 6

7. Apply hydraulic oil to the floating seal (1).

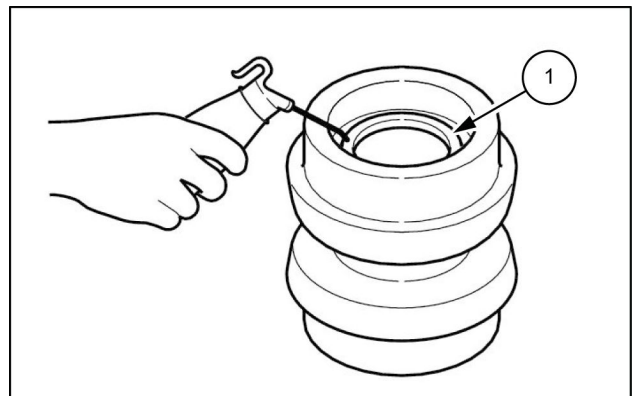

LPIL12CX01264AB 7

8. Attach the shaft (2) to the roller (1).

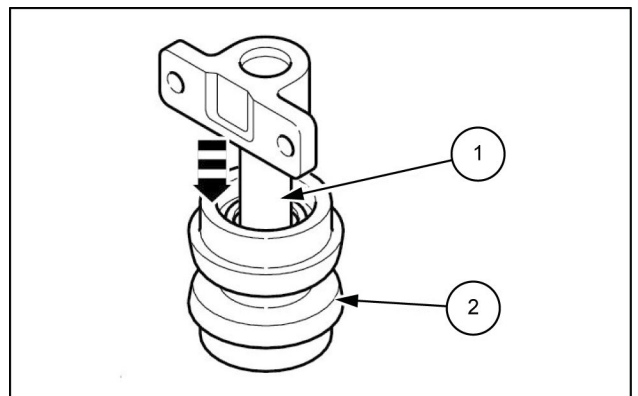

LPIL12CX01265AB 8

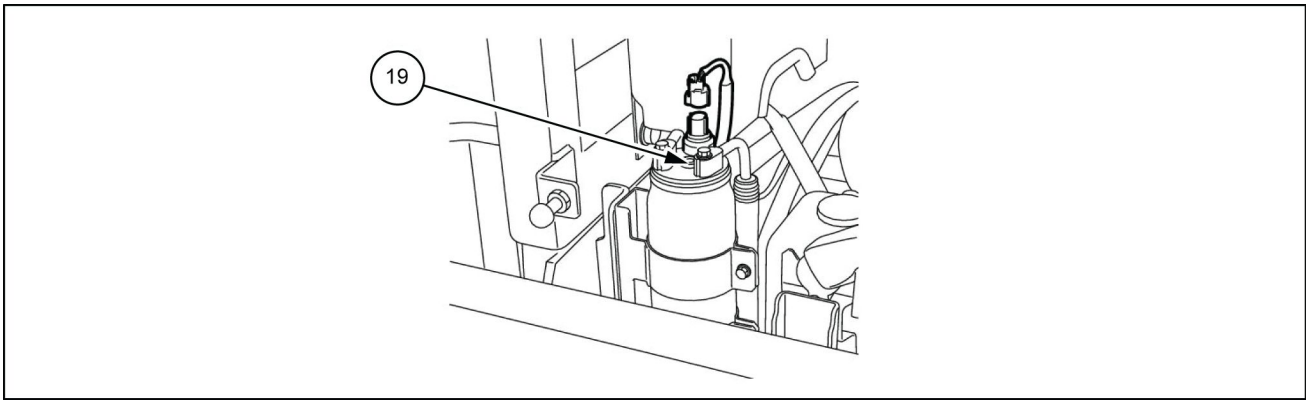

SMIL13CEX1105EB 6

Judgment of refrigerant volume seen from the sight glass of the receiver dryer

Adequate

You can see a few bubbles after A/C-ON and then it turns to clear and show thin milky color

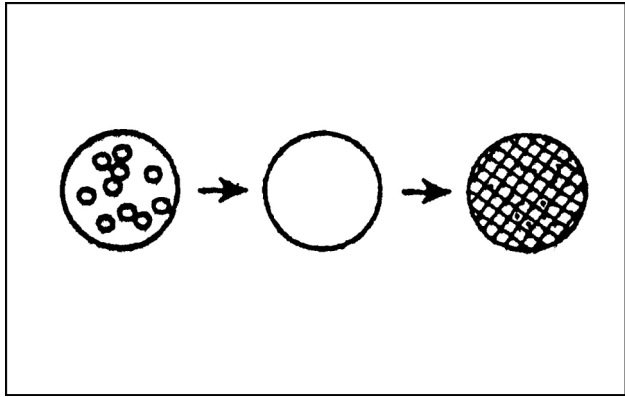

SMIL14CEX1840AA 7

Excessive filling

No bubble is seen after A/C-ON

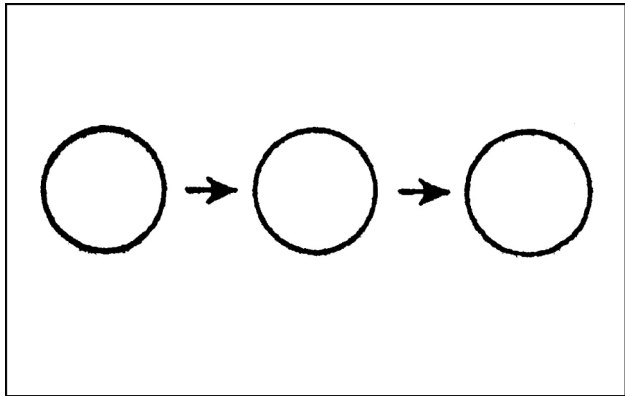

SMIL14CEX1841AA 8

Insufficient filling volume

Continuous bubbles are seen after A/C-ON

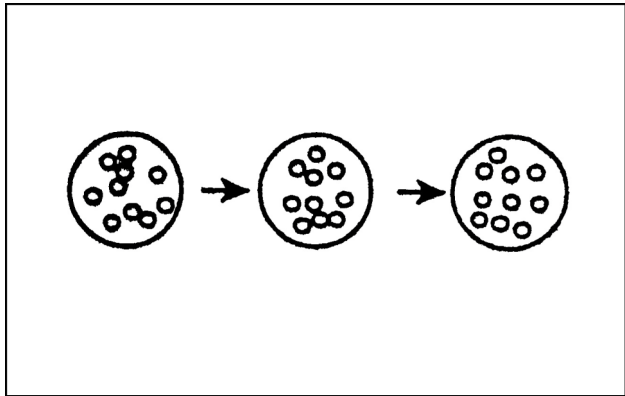

SMIL14CEX1842AA 9

Total gas filling volume: 950 - 1050 g (33.5 - 37.0 oz)

Pressure sensor

(P1) (P2)

(boom bottom)

(arm bottom)

(arm rod)

Specification: **50 MPa (7252.5 psi)**

Part No.: KHR10290

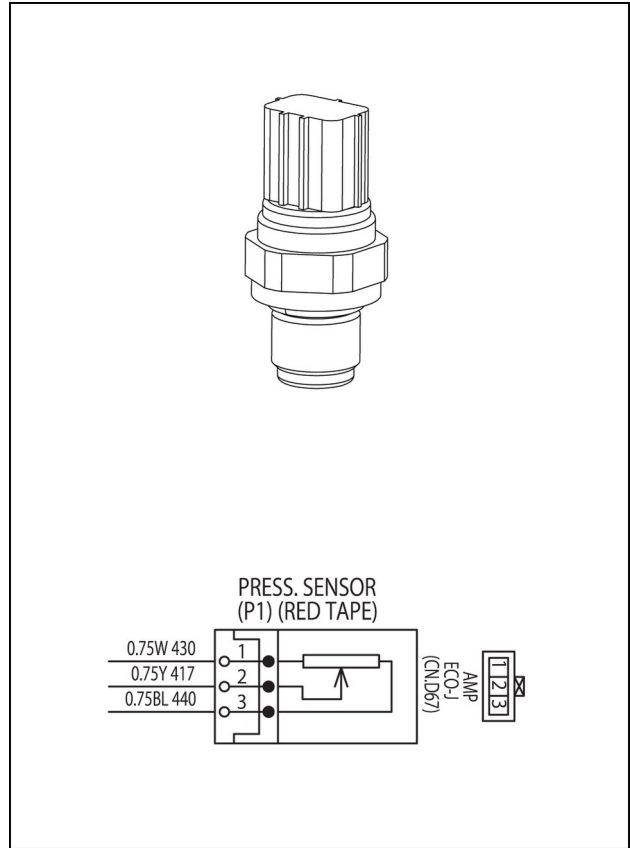

SMPH15CEX7124BA 29

Pressure sensor

(N1) (N2)

(swing)

(upper)

(travel)

(option)

Specification: **5 MPa (725.2 psi) 5 MPa**

Part No.: KHR26940

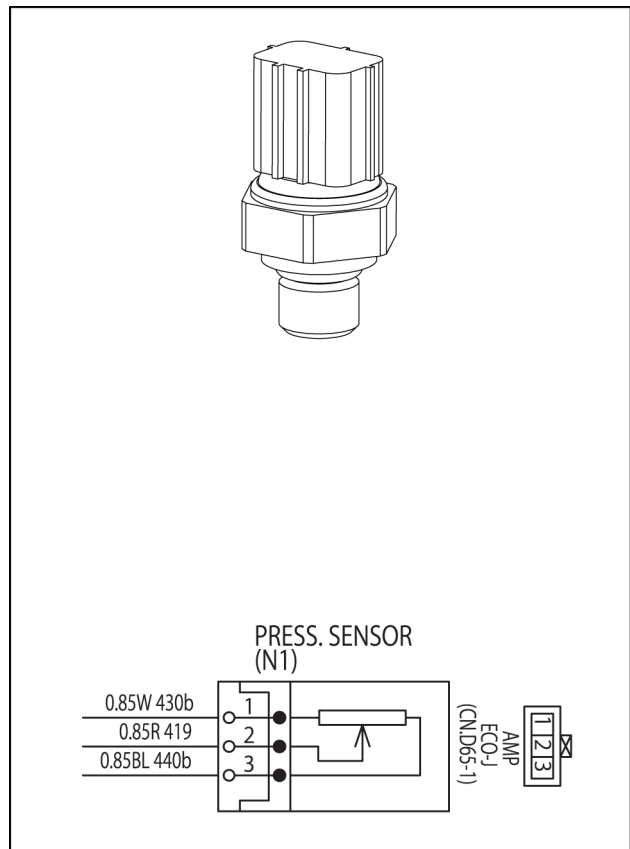

SMIL14CEX4123BA 30

Main unit right side layout diagram (pump chamber)

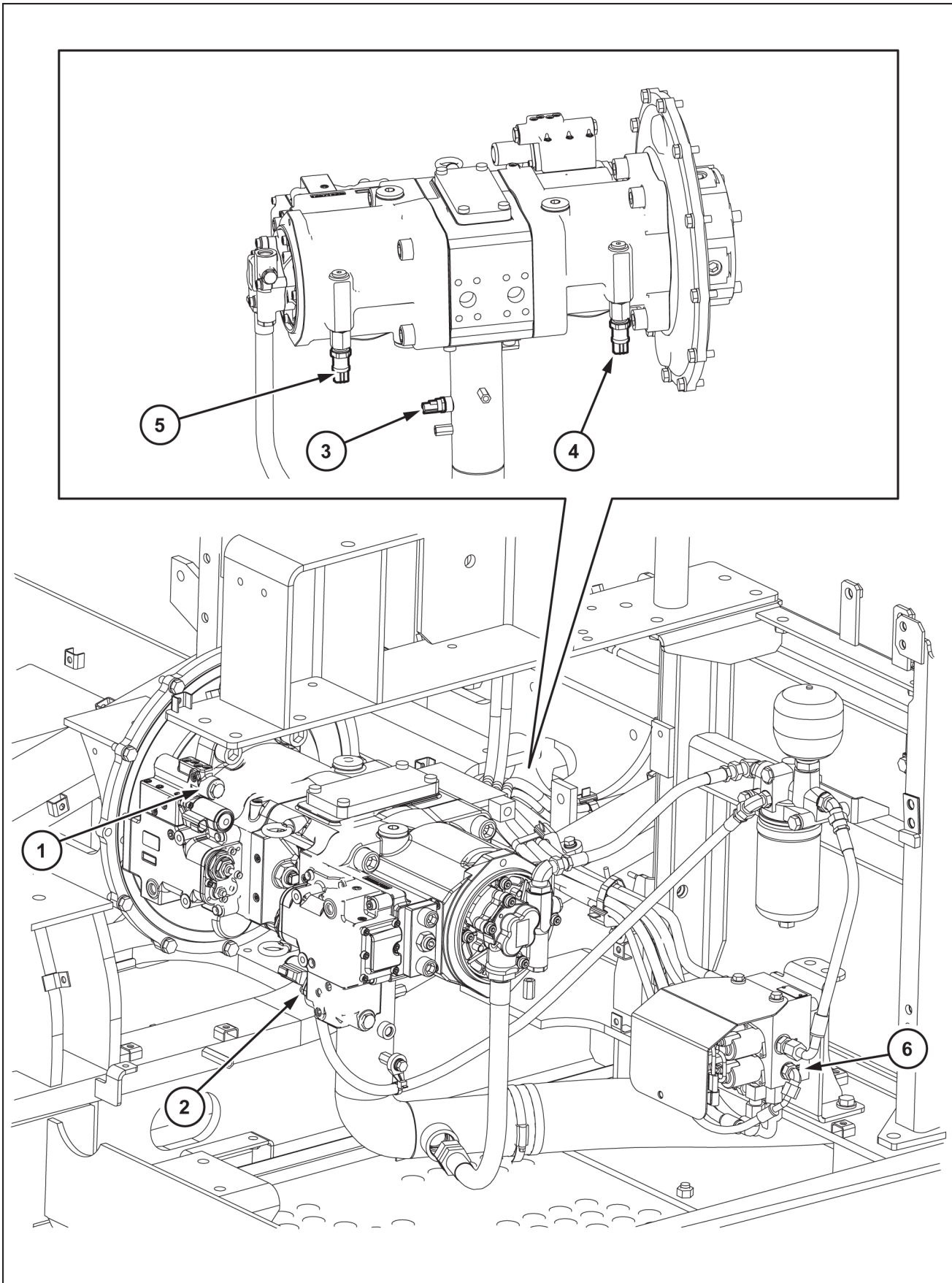

SMIL15CEX0610HB 5

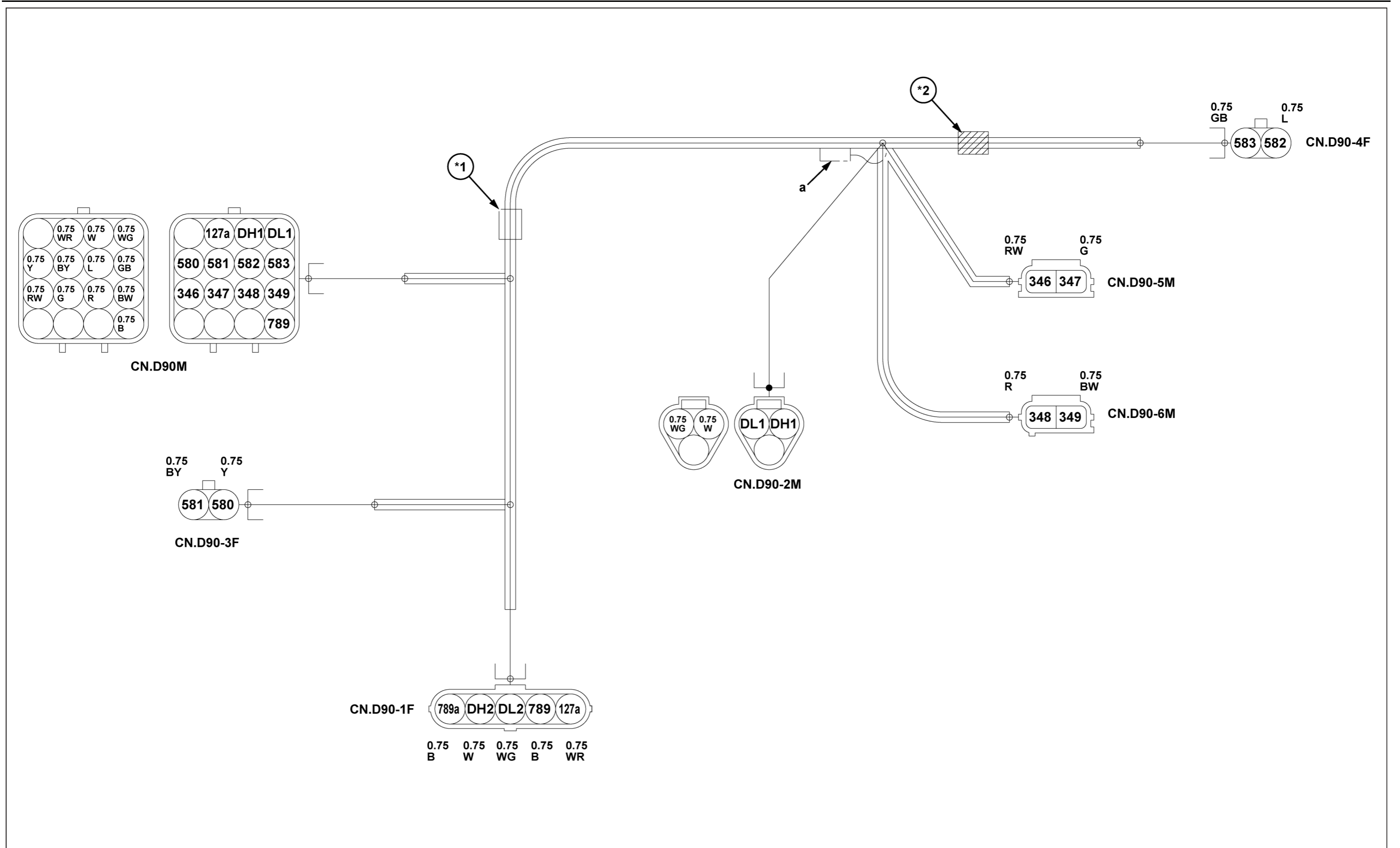

Camera intermediate harness [8000 mm (314.961 in)]

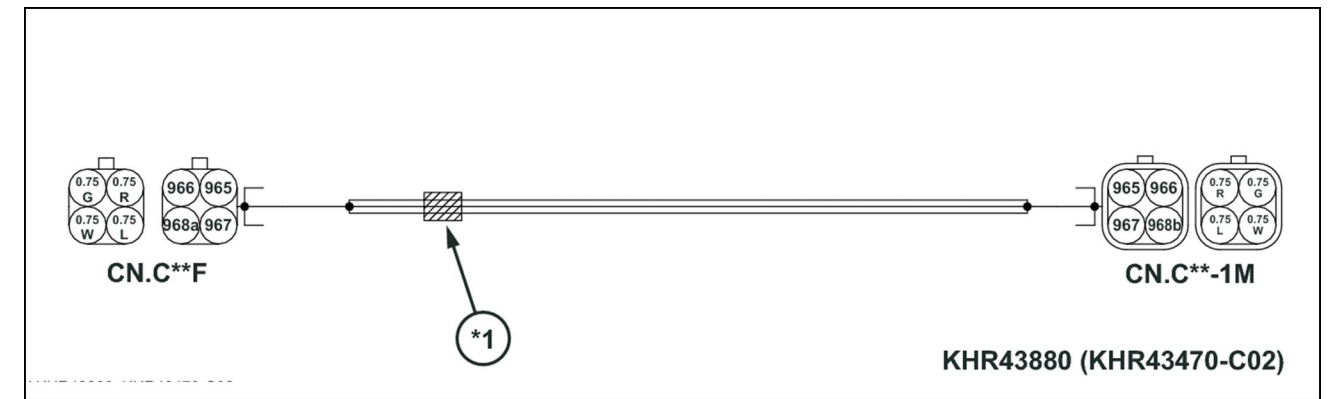

SMIL15CEX6341EB 16

*1. Plate

CN.C**F	Cab harness: CCD
CN.C**-1M	CCD harness

Camera intermediate harness [7000 mm (275.591 in)]

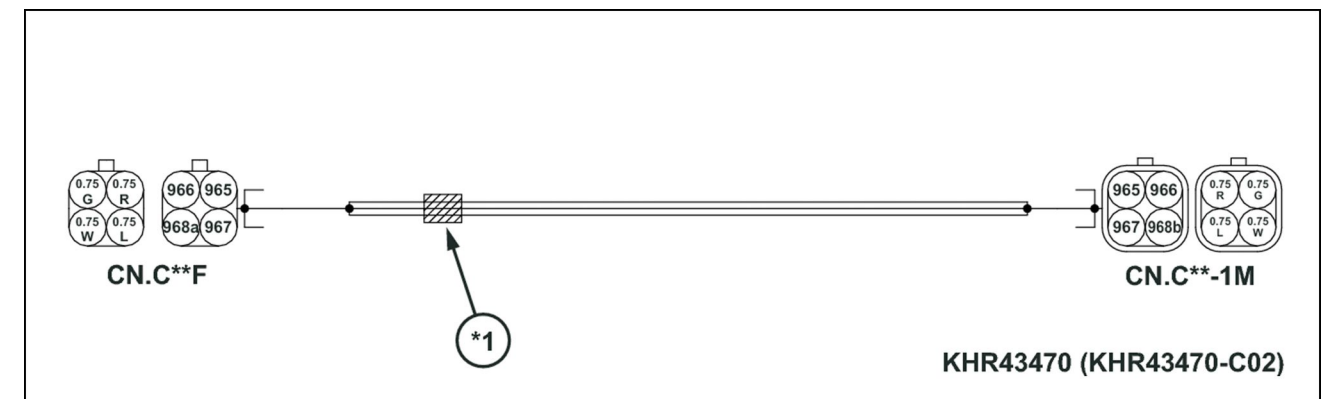

SMIL15CEX6342EB 17

*1. Plate

CN.C**F	Cab harness: CCD
CN.C**-1M	CCD harness

Electrical systems - Harnesses and connectors

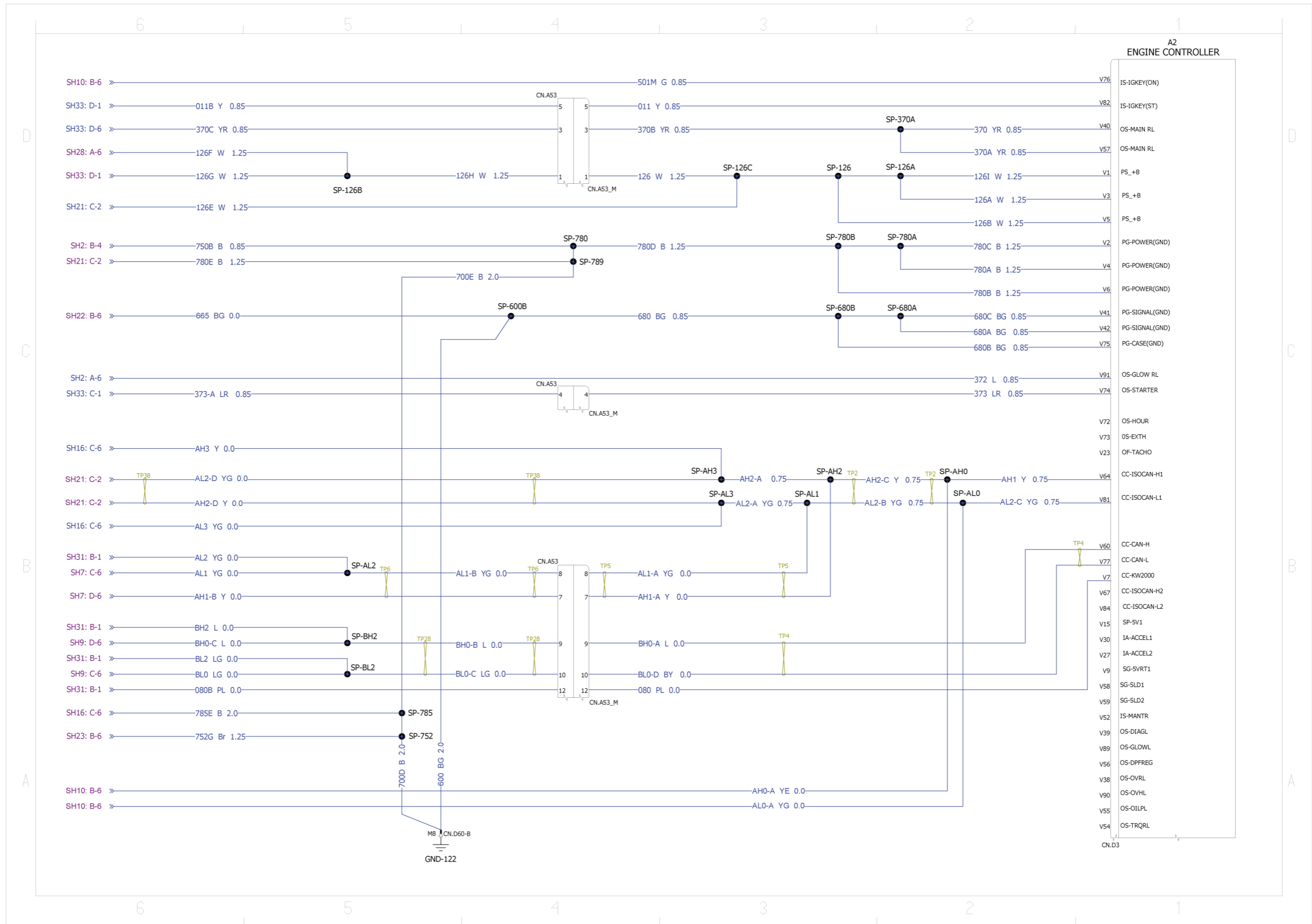

Wiring harnesses - Electrical schematic sheet 32 - Cab - inter connector

Type	Component	Connector/Link	Description
Connector	CN.A19	CN.A19	EST connector B
Connector	CN.A35	CN.A35	
Connector	CN.A36	CN.A36	-
Connector	CN.A51	CN.A51	-

CONNECTOR CN.B1: Key switch (Male)

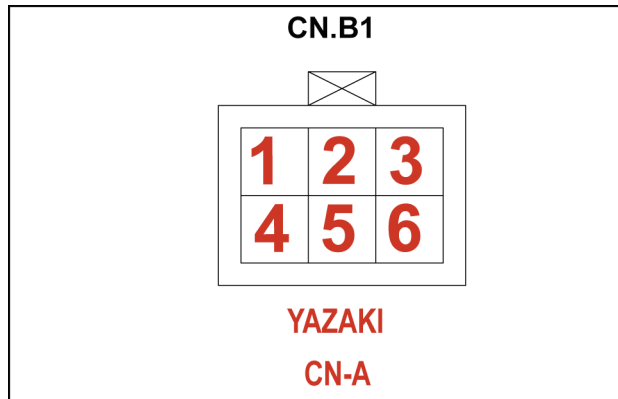

SMIL15CEX1416AA 19

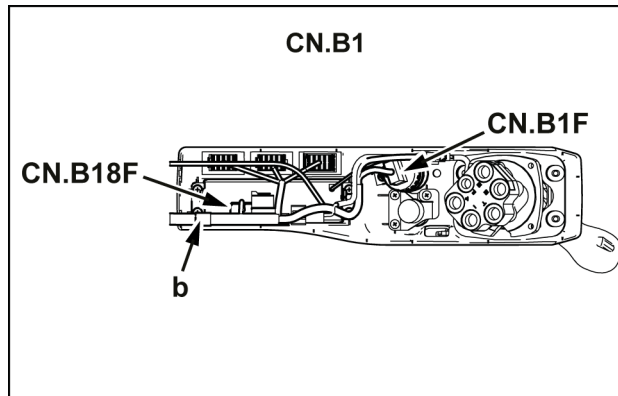

SMIL15CEX1904AA 20

Pin	From	Wire	Description	Color-Size	Frame
1	CN.A42_M-P-5	010A		BrR-0.85	Wiring harnesses - Electrical schematic sheet 39 (55.100)
3	CN.A42_M-P-2	290A		RB-0.85	
4	CN.A42_M-P-1	110A		R-0.85	
6	CN.A42_M-P-4	500A		LgR-0.85	

CONNECTOR CN.F1: Relay compressor (Male)

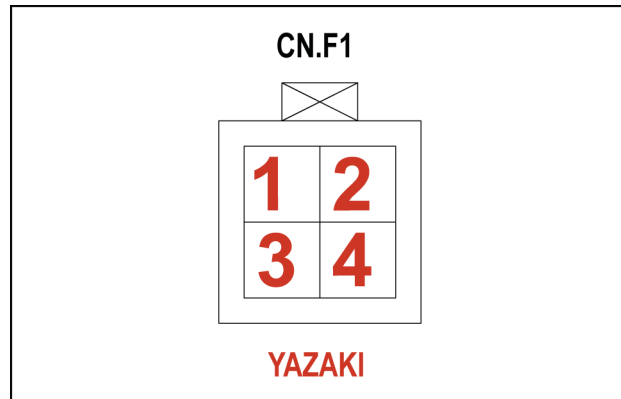

SMIL15CEX1914AA 68

Pin	From	Wire	Description	Color-Size	Frame
1	SP-180A-P-X	180D		LR-0.85	Wiring harnesses - Electrical schematic sheet 28 (55.100)
2	SP-180A-P-X	180A		LR-0.85	
3	CN.B16-P-4	943B		GW-0.85	
4	CN.B17-P1	942A		BrW	

CONNECTOR CN.B16: Air conditioner unit (Female)

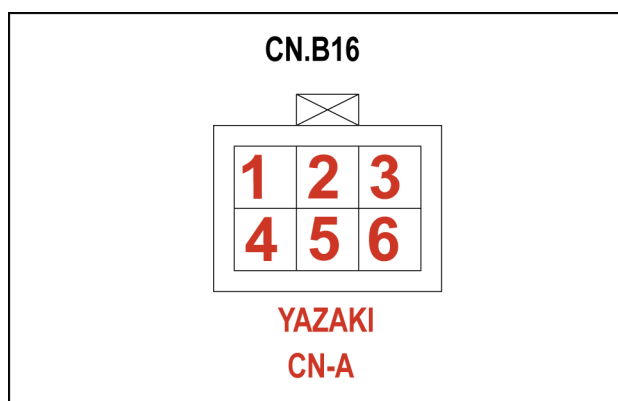

SMIL15CEX1080AA 29

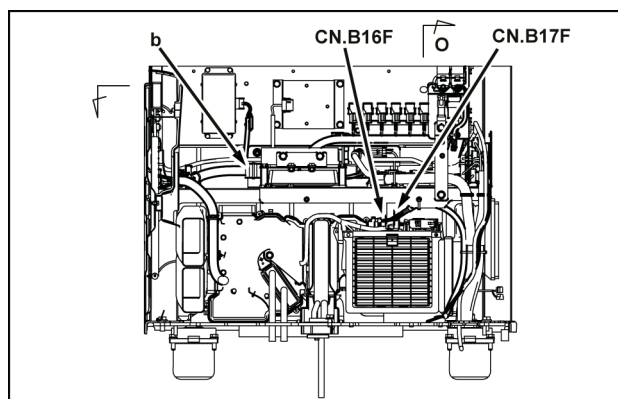

SMIL15CEX1079AA 30

Pin	From	Wire	Description	Color-Size	Frame
1	CN.F2-P-1	175B		WR-2.0	Wiring harnesses - Electrical schematic sheet 28 (55.100)
2	SP-180A-P-X	180C		LR-0.85	
3	CN.F2-P-X	170D		VR	
4	CN.F1-P-X	943B		GW-0.85	
6	CN.F4-P-1	732		B-2.0	

CONNECTOR CN.G11: Pressure sensor (pilot option-1) (Female)

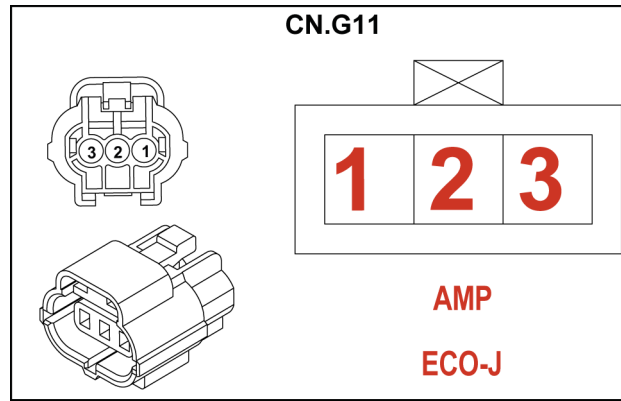

SMIL15CEX1577AA 66

Pin	From	Wire	Description	Color-Size	Frame
1	CN.D83-P-1	435-F		WB-0.85	Wiring harnesses - Electrical schematic sheet 24 (55.100)
2	CN.D83-P-3	415B		WL-0.85	
3	CN.D83-P-4	445-F		BW-0.85	

CONNECTOR CN.C24: Room lamp (Female)

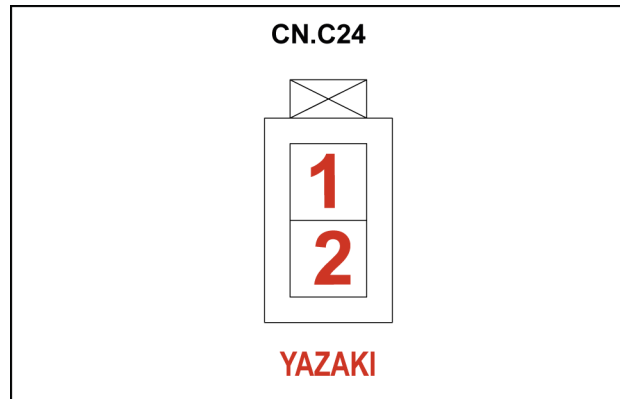

SMIL15CEX1942AA 30

Pin	From	Wire	Description	Color-Size	Frame
1	CN.C8-P-2	843		Y	Wiring harnesses - Electrical schematic sheet 38 (55.100)
2	CN.C8-P-1	888B		G	

CONNECTOR CN.A36: Joint connector B (Male)

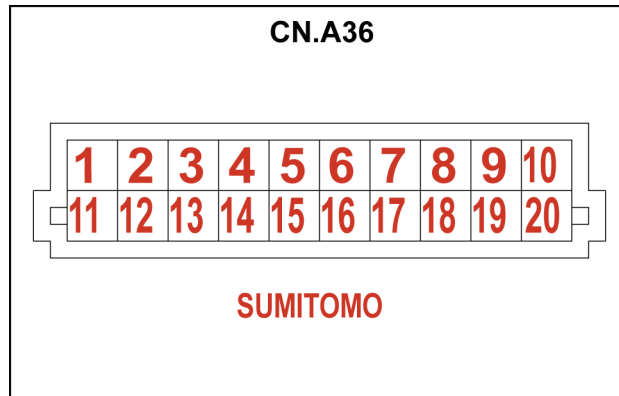

SMIL15CEX2024AA 9

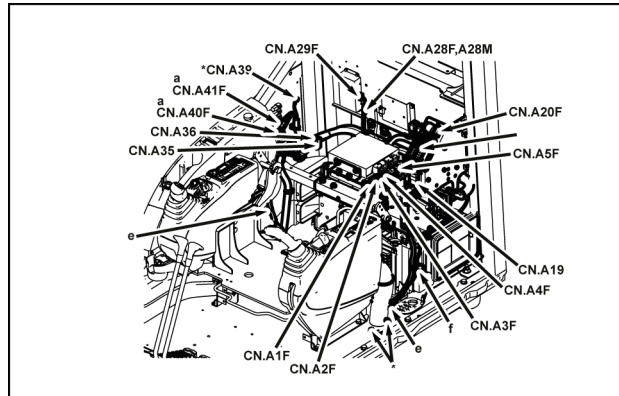

SMIL15CEX2023AA 10

Pin	From	Wire	Description	Color-Size	Frame
1	CN.A3-P-7	CL0		PG	Wiring harnesses - Electrical schematic sheet 32 (55.100)
2	CN.A4-P-31	CL1		PG	
3	CN.A40 M-P-5	CL2-		PG	
4	CN.A44-P11	CL3		PG	
5	CN.A27-P-8	CL4		PG	
7	CN.A20 M-P-9	CL6		PG	
11	SP-600A-P-X	600F		BG-1.25	
12	CN.A47M-P-1	605		BG	
13	CN.A40 M-P-14	610		BG-1.25	
14	CN.A42-P-10	620		BG-0.85	
15	CN.A21 M-P-1	630		BG	
16	CN.A19 M-P-2	631		BG	
17	SP-635-P-X	634		BG	
18	CN.A27-P-10	636		BG-1.25	
19	CN.A54-P-21	660A		BG-0.85	
20	SP-600A-P-X	600A		BG-1.25	

CONNECTOR CN.D42 : Fuel filter pressure sensor (Male)

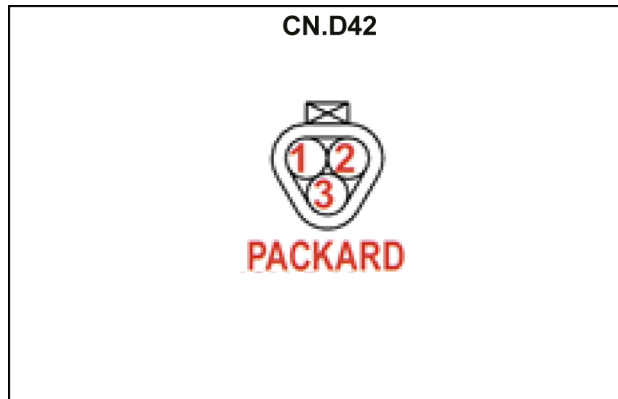

SMIL15CEX1539AA 31

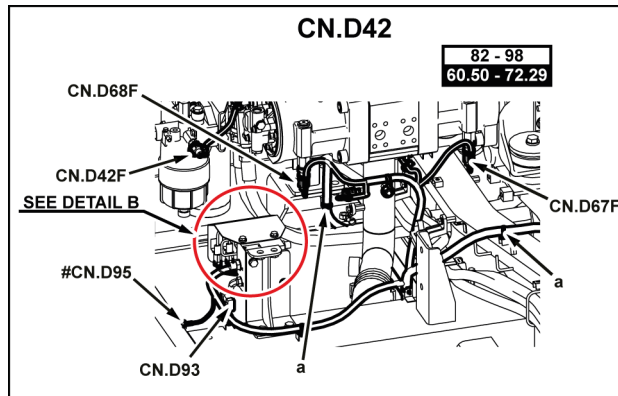

SMIL15CEX1955AA 32

Pin	From	Wire	Description	Color-Size	Frame
1	SP-349A-P-X	349A		BW-0.75	SHEET 20
2	CN.D3-P-V16	334		WB-0.75	
3	CN.D3-P-V17	335		GW-0.75	

CONNECTOR CN.D60-B: GND-122

Pin	From	Wire	Description	Color-Size	Frame
M8	SP-600B-P-X	600		BG-2.0	Wiring harnesses - Electrical schematic sheet 13 (55.100)
M8	SP-752-P-X	700D		B-2.0	

CONNECTOR CN.D81 (Male)

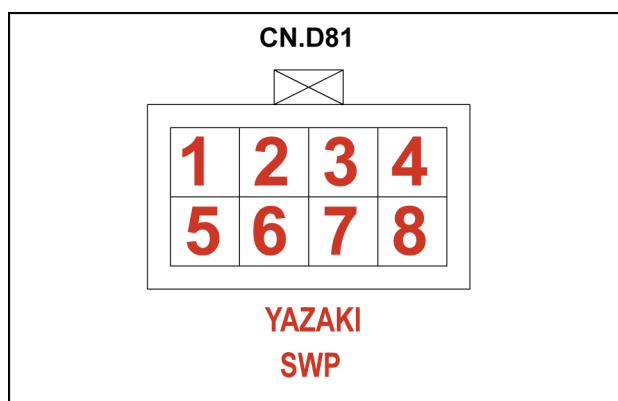

SMIL15CEX2002AA 5

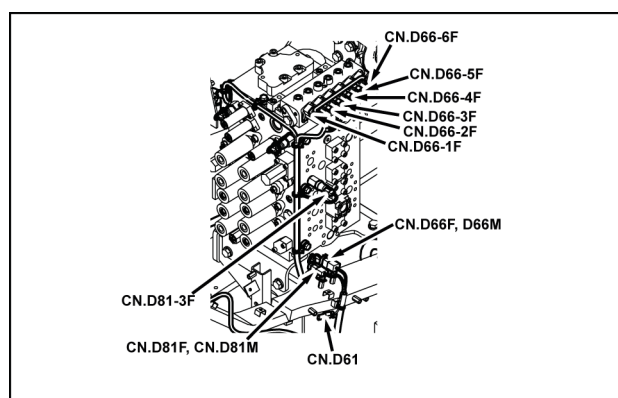

SMIL15CEX1059AA 6

Pin	From	Wire	Description	Color-Size	Frame
1	SP-430C-P-X	430B-2		W-0.85	Wiring harnesses - Electrical schematic sheet 12 (55.100)
2	SP-440C-P-X	440F		BL-0.85	
3	CN.D65-1-P-2	419B		R-0.85	
4	CN.D65-2-P-2	420B		G-0.85	
5	SP-435I-P-X	435E		WL-0.85	
6	SP-445O-P-X	445K		BW-0.85	
7	CN.D65-3-P-2	402B		BrW-0.85	
8	CN.D65-4-P-2	403B		BrR-0.85	

Cab engine controls - Dynamic description - One-touch idle

Purpose/overview

The system lowers speed to low idle speed when the one-touch idle switch is pressed, and resumes to original speed if it is pressed again.

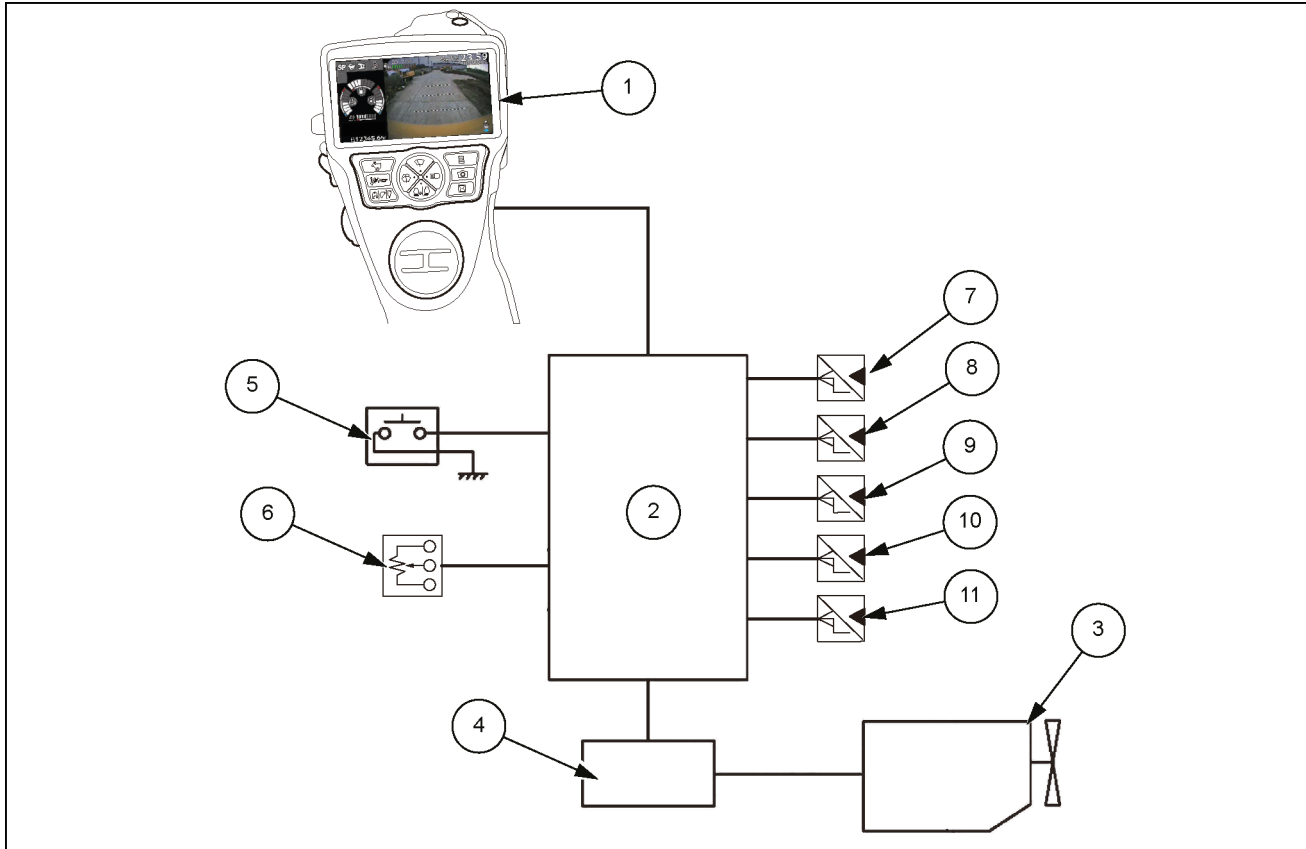

SMIL14CEX3433FB 1

- | | |
|--------------------------|-------------------------------|
| 1. Monitor | 7. Pressure sensor (option 1) |
| 2. Main controller | 8. Pressure sensor (option 2) |
| 3. Engine | 9. Pressure sensor (upper) |
| 4. ECM | 10. Pressure sensor (swing) |
| 5. One-touch idle switch | 11. Pressure sensor (travel) |
| 6. Throttle volume | |

Operation condition

The one-touch idle is activated with the following conditions.

- When the one-touch idle switch is pressed.
- The operation lever is not operated. (Either one of the following pressure sensors is OFF; upper, swing, travel, option 1, option 2)

Stop condition

The one-touch idle is released with the following conditions.

- When the one-touch idle switch is pressed during one-touch idle.
- When the operation lever is operated. (Either one of the following pressure sensors is ON; upper, swing, travel, option 1, option 2)
- When the throttle volume is operated.

Control during ignition switch OFF state

There are 2 types of controls provided when the ignition switch is turned OFF after the idling control switch is operated, and either one of them is performed depending on the specification. The engine speed adjusted by the idling control switch is recorded in the ECM, and the next time the vehicle is operated, the engine speed is set to the speed it was at when the ignition switch was turned OFF.

The engine speed adjusted by the idling control switch is not recorded in the ECM, and the next time the vehicle is operated, the engine speed is set to the default speed.

For verification and questions regarding the specifications, contact an Isuzu service representative.

Idle manual control

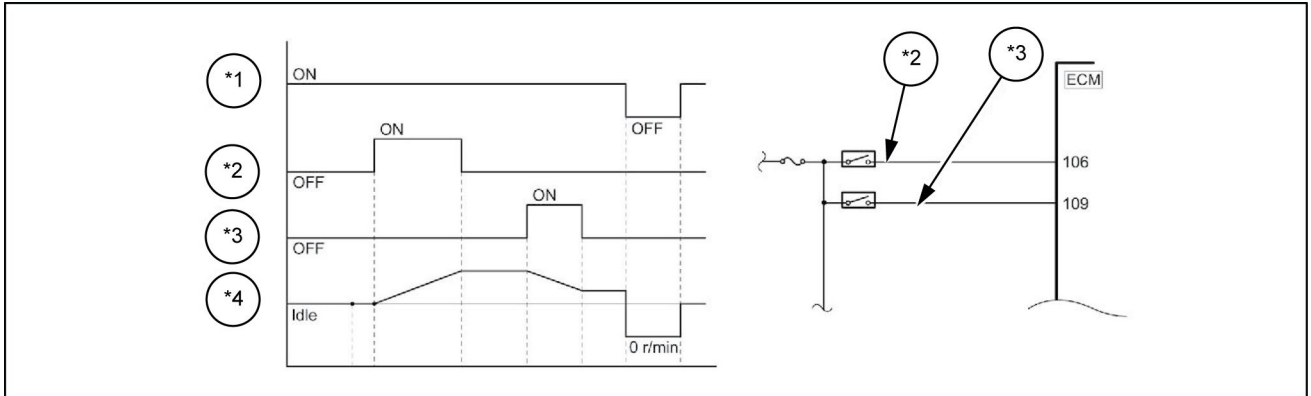

SMIL13CEX1735EB 30

- *1. Starter switch
- *2. Idle up switch
- *3. Idle down switch
- *4. Engine speed

Engine speed output to tachometer The ECM outputs the engine speed pulse to the tachometer as a tachometer output. The tachometer displays the engine speed based on the engine speed pulse sent from the ECM.

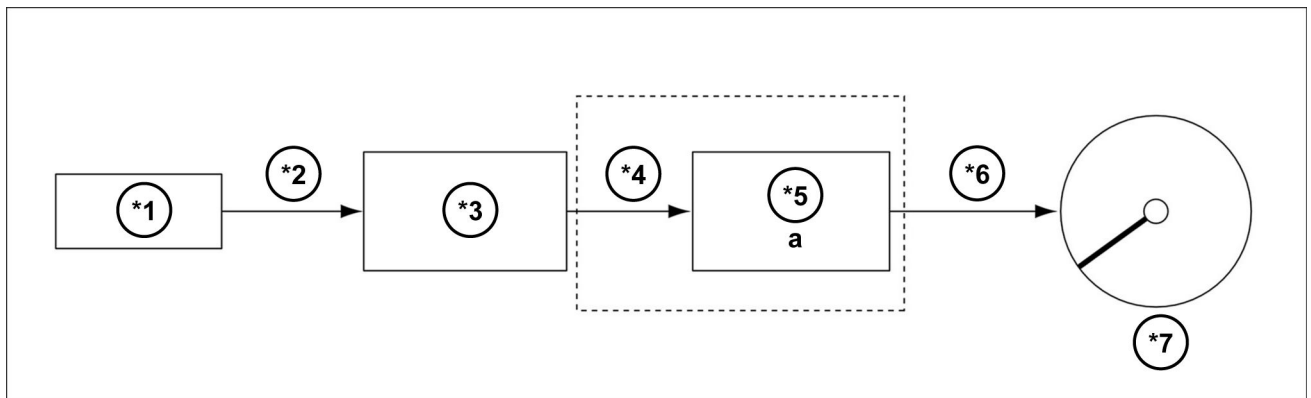

SMIL15CEX0345EB 31

- *1. CKP sensor
- *2. Engine speed
- *3. Engine Control Module (ECM)
- *4. CAN communication
- *5. Control unit on machine side
- *6. Tachometer output
- *7. Tachometer

Engine timing sensors Camshaft sensor - Remove

Battery ground cable disconnect

1. Disengage the battery ground cable from the battery.

CMP sensor removal

1. Disengage the harness connector from the CMP sensor.
2. Remove the CMP sensor from the cylinder head assembly.

 **CAUTION:** Be careful not to subject the sensor to shock.

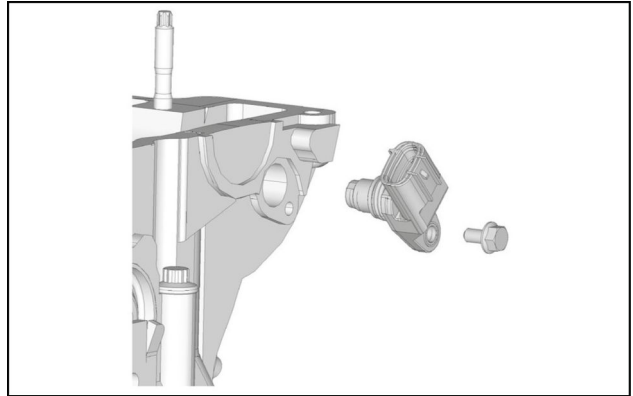

SMIL14CEX3024AA 1

The ECM and monitor are operating correctly.

Check DTCs.

Check the condition of the actual machine and find applicable symptoms. Confirm with the customer that the stipulated engine oil and fuel are being used.

Visual inspection

Some symptoms detection procedures require careful visual inspection.

This allows for problems to be repaired without performing further inspection, which saves valuable time.

The following items are included in this inspection.

Is bluish smoke continuously produced during engine running?

Is excessive blow-by gas being produced? Check for any oil mixed in with the coolant.

Check that pipes and hoses for oil are not broken or twisted and that they are correctly connected.

Thoroughly check for any leaking or clogging.

Check for oil leaks and damage and denting on pipes in the lubrication system.

Check the turbocharger and other suction air system parts abnormalities.

Diagnostic aid

Decline of oil, rise of oil, excessive blow by gas and other suction air system abnormalities.

Engine abnormality caused by oil combustion and excessive blow-by gas.

Also, perform functional diagnosis inspection, check operations and control in each area, and repair any abnormalities.

Engine output deficiency - symptoms

The engine output is lower than expected, output does not change even if the engine throttle switch (throttle lever) is raised, and responsiveness is poor.

Engine output deficiency - diagnosis

Preliminary inspection

Before using this section, perform a functional inspection and OBD system check to check all of the following items.

The ECM and monitor are operating correctly.

Check DTCs. The scan tool data is within the normal operation range.

Check the condition of the actual machine and find applicable symptoms.

Intake air pressure and temperature sensor - Remove

1. Disconnect the battery ground cable from the battery.
2. Remove the harness connector from the boost pressure sensor/boost temperature sensor **(5)**.
3. Remove the boost pressure sensor/ boost temperature sensor **(5)** from the inlet pipe.
 1. Intake manifold temperature sensor
 2. EGR gas temperature sensor 2
 3. EGR valve
 4. Harness clip
 5. Boost pressure sensor/boost temperature sensor

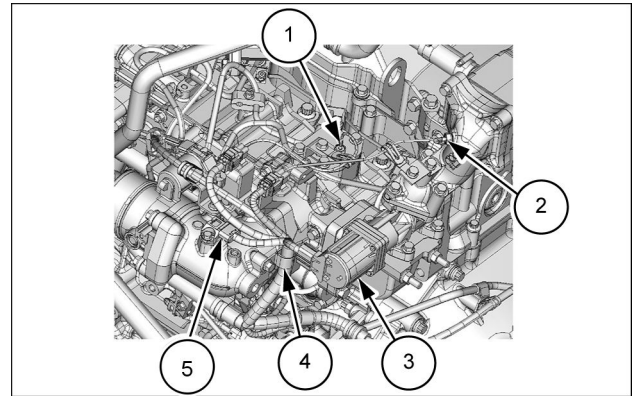

SMIL15CEX0365A 1

Electrical systems - Selective Catalytic Reduction (SCR) electrical system

13	–
14	–
15	–
16	–
17	Urea fluid pressure sensor signal
18	Urea fluid pressure sensor GND
19	Urea fluid pressure sensor power supply
20	–
21	–
22	–
23	–
24	Urea fluid pump motor PWM
25	–
26	Urea fluid pump motor GND
27	–
28	–
29	–
30	–
31	–
32	Dosing module (High)
33	EGT sensor signal
34	EGT sensor GND
35	–
36	–
37	–
38	–
39	–
40	–
41	–
42	–
43	–
44	–
45	–
46	Urea fluid pump motor power supply
47	–
48	–
49	–
50	–
51	–
52	–
53	–
54	–
55	–
56	–
57	–
58	Urea fluid tank level sensor, urea fluid tank temperature sensor GND
59	Urea fluid tank level sensor signal
60	–
61	–
62	–
63	–
64	–
65	Reverting valve control
66	–
67	–
68	–
69	–
70	–

4. Remove the connector **(1)** to remove the 2 clamps **(2)**.
Remove the 2 coolant hoses **(3)**.
Remove the 3 urea hoses **(4)**.
Remove the 3 bolts **(5)** with a wrench [**13 mm**] to remove the urea pump **(6)**.
- Attach caps and plugs at the hoses so as to prevent invasion of water, dust and dirt.
 - Apply marking at each location of the hoses so as to match connections at assembling.

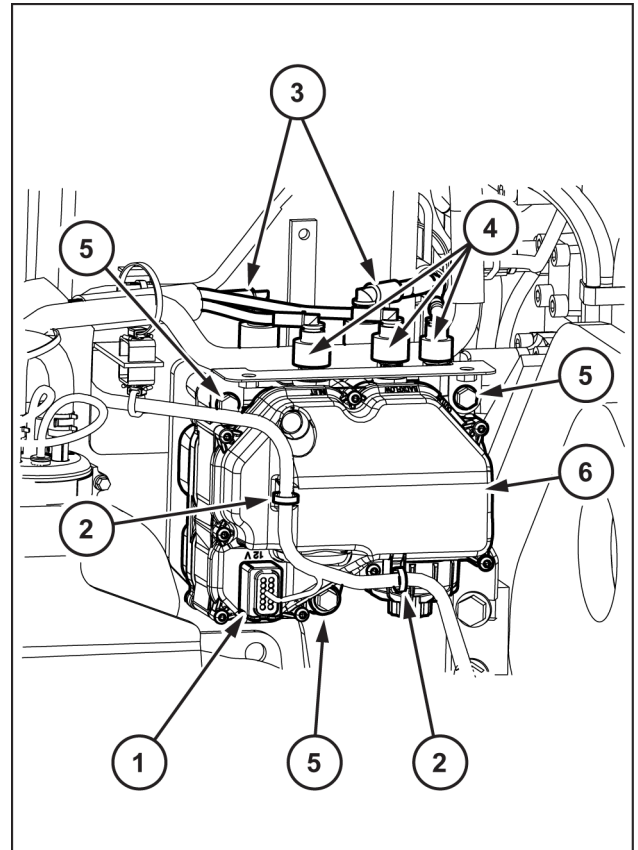

SMIL15CEX0643BB 4

Coolant high temperature sensor - Install

Overheat switch installation

1. Install the overheat switch (1) to the cylinder head assembly.

Tightening torque: **29 N·m (21.4 lb ft)**

NOTE: Apply **LOCTITE® 572™** to the threaded portion.

2. Connect the harness connector to the overheat switch (1).

(2) Water temperature sensor

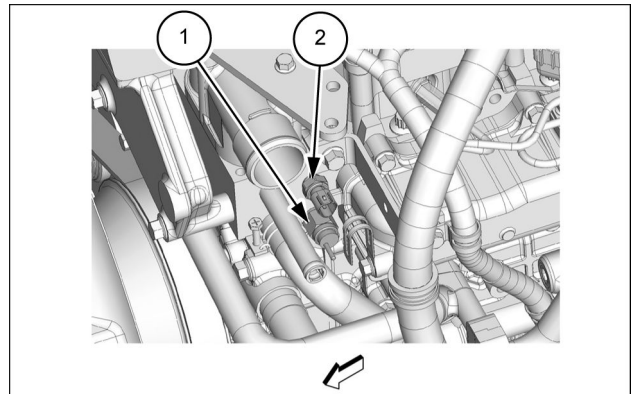



SMIL15CEX0366A 1

Instrument cluster - Overview - CHECK screen list

In CHECK mode, not only the system status (each current value, hydraulic pressure, temperature, etc.) but also the input/output state of sensors and switches can be checked.

1. Section

Refer to the attached sheet for the types of sections in the CHECK mode and their descriptions.

By pressing  and  on the monitor, MACHINE STATUS, HYDRAULIC HISTORY, etc. can be selected.

Detailed data for the selected item can be seen by pressing

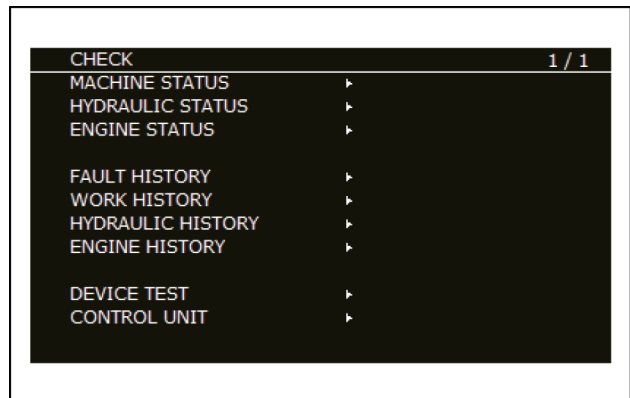

SMIL14CEX0914AB 1

MACHINE STATUS

1/9

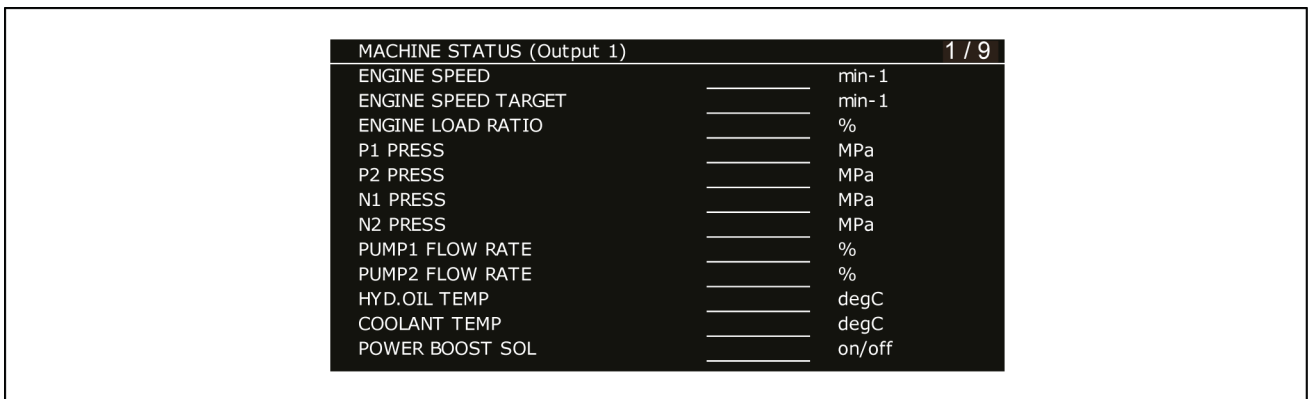

SMIL14CEX0915EB 2

Display	Explanation	Range
ENGINE SPEED	Actual engine speed	0 - 2500 RPM
ENGINE SPEED TARGET	target engine speed	500 - 2500 RPM
ENGINE LOAD RATIO	Engine torque (load ratio)	0 - 100 %
P1 PRESS	P1 pressure	0 - 50 MPa (0 - 7253 psi)
P2 PRESS	P2 pressure	0 - 50 MPa (0 - 7253 psi)
N1 PRESS	N1 pressure	0 - 5 MPa (0 - 725 psi)
N2 PRESS	N2 pressure	0 - 5 MPa (0 - 725 psi)
PUMP1 FLOW RATE	Pump 1 target flow rate	0 - 100 %
PUMP2FLOW RATE	Pump 2 target flow rate	0 - 100 %
HYD.OIL TEMP	Temperature sensor; hydraulic oil	-40 - 210 °C (-40 - 410 °F)
COOLANT TEMP	Coolant temperature	-40 - 210 °C (-40 - 410 °F)
POWER BOOST SOL	Pressure boost solenoid	ON/OFF

10/11

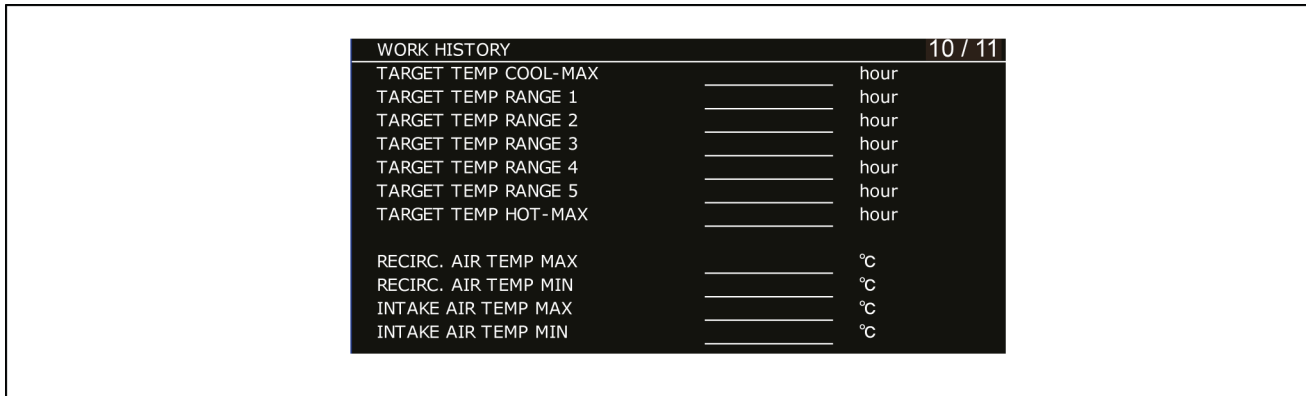

SMIL14CEX0952EA 39

Display	Explanation	Unit	Judgment condition	Judgment start condition
TARGET TEMP. COOL- MAX	AC set temperature; time distribution	hour	Set temperature < 18.5 °C (65.3 °F)	Key ON
TARGET TEMP. RANGE 1	AC set temperature; time distribution	hour	Set temperature < 22 °C (71.6 °F)	Key ON
TARGET TEMP. RANGE 2	AC set temperature; time distribution	hour	Set temperature < 24 °C (75.2 °F)	Key ON
TARGET TEMP. RANGE 3	AC set temperature; time distribution	hour	Set temperature < 26.5 °C (79.7 °F)	Key ON
TARGET TEMP. RANGE 4	AC set temperature; time distribution	hour	Set temperature < 28.5 °C (83.3 °F)	Key ON
TARGET TEMP. RANGE 5	AC set temperature; time distribution	hour	Set temperature < 32 °C (89.6 °F)	Key ON
TARGET TEMP. HOT-MAX	AC set temperature; time distribution	hour	Set temperature \geq 32 °C (89.6 °F)	Key ON
RECIRC.AIR TEMP MAX	Highest inside air temperature	C (°F)		Key ON
RECIRC.AIR TEMP MIN	Lowest inside air temperature	C (°F)		Key ON
INTAKE AIR TEMP MAX	Highest outside air temperature	C (°F)		Key ON
INTAKE AIR TEMP MIN	Lowest outside air temperature	C (°F)		Key ON

17/31

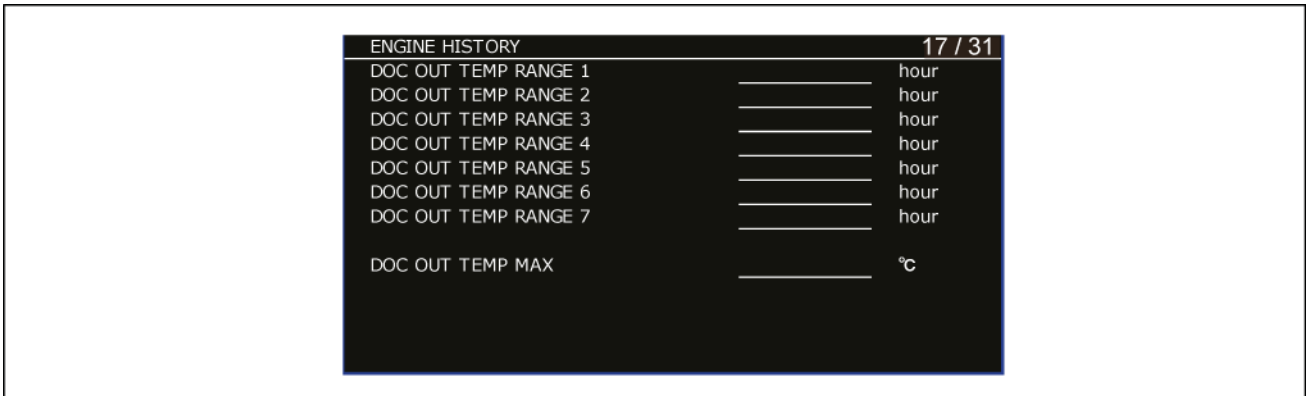

SMIL14CEX0989EA 76

Display	Explanation	Unit	Judgment condition	Judgment start condition
DOC OUT TEMP RANGE 1	DOC outlet temperature; time distribution	hour	Less than 200 °C	In 10 s after the engine starts
DOC OUT TEMP RANGE 2	DOC outlet temperature; time distribution	hour	Less than 300 °C	In 10 s after the engine starts
DOC OUT TEMP RANGE 3	DOC outlet temperature; time distribution	hour	Less than 400 °C	In 10 s after the engine starts
DOC OUT TEMP RANGE 4	DOC outlet temperature; time distribution	hour	Less than 500 °C	In 10 s after the engine starts
DOC OUT TEMP RANGE 5	DOC outlet temperature; time distribution	hour	Less than 600 °C	In 10 s after the engine starts
DOC OUT TEMP RANGE 6	DOC outlet temperature; time distribution	hour	Less than 700 °C	In 10 s after the engine starts
DOC OUT TEMP RANGE 7	DOC outlet temperature; time distribution	hour	700 °C or more	In 10 s after the engine starts
DOC OUT TEMP MAX	Maximum value of DOC outlet temperature	°C (°F)	–	In 10 s after the engine starts

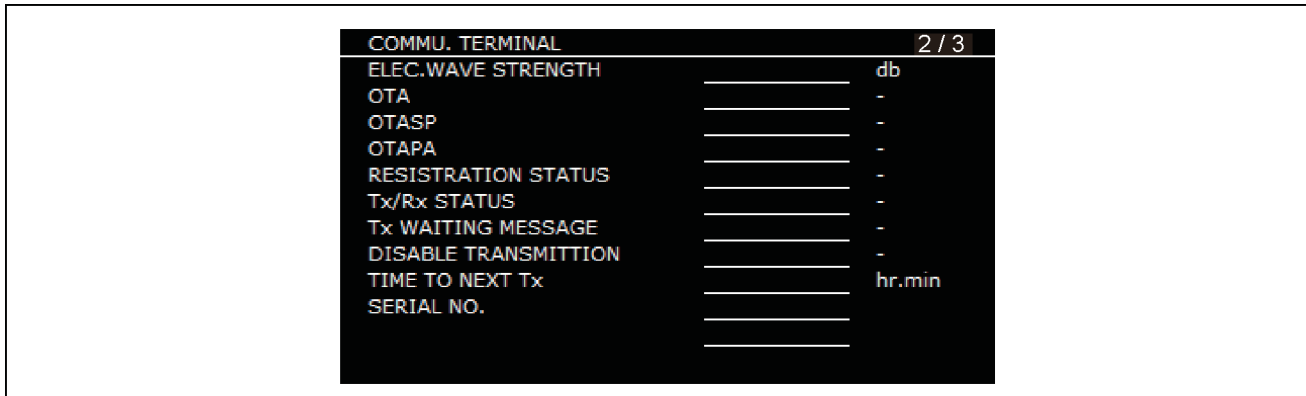

SMIL14CEX1121EA 114

Display	Explanation	Unit
ELEC.WAVE STRENGTH	Strength of electric wave	db
OTA	OTA status	-
OTASP	OTASP status	-
OTAPA	OTAPA status	-
RESISTRATION STATUS	Registration (initial setting communication) status	-
Tx/Rx STATUS	Transmitting/receiving status (Transmitting/receiving/idling)	-
Tx WAITING MESSAGE	Number of messages waiting to be transmitted	-
DISABLE TRANSMISSION	Setting to disable transmission	-
TIME TO NEXT Tx	Time to next transmission	hr.min
SERIAL NO.	Serial number of terminal	

Instrument cluster - Dynamic description - Monitor display dimming

Purpose/overview

Brightness of backlight is adjusted in accordance with the working light and solar radiation sensor.

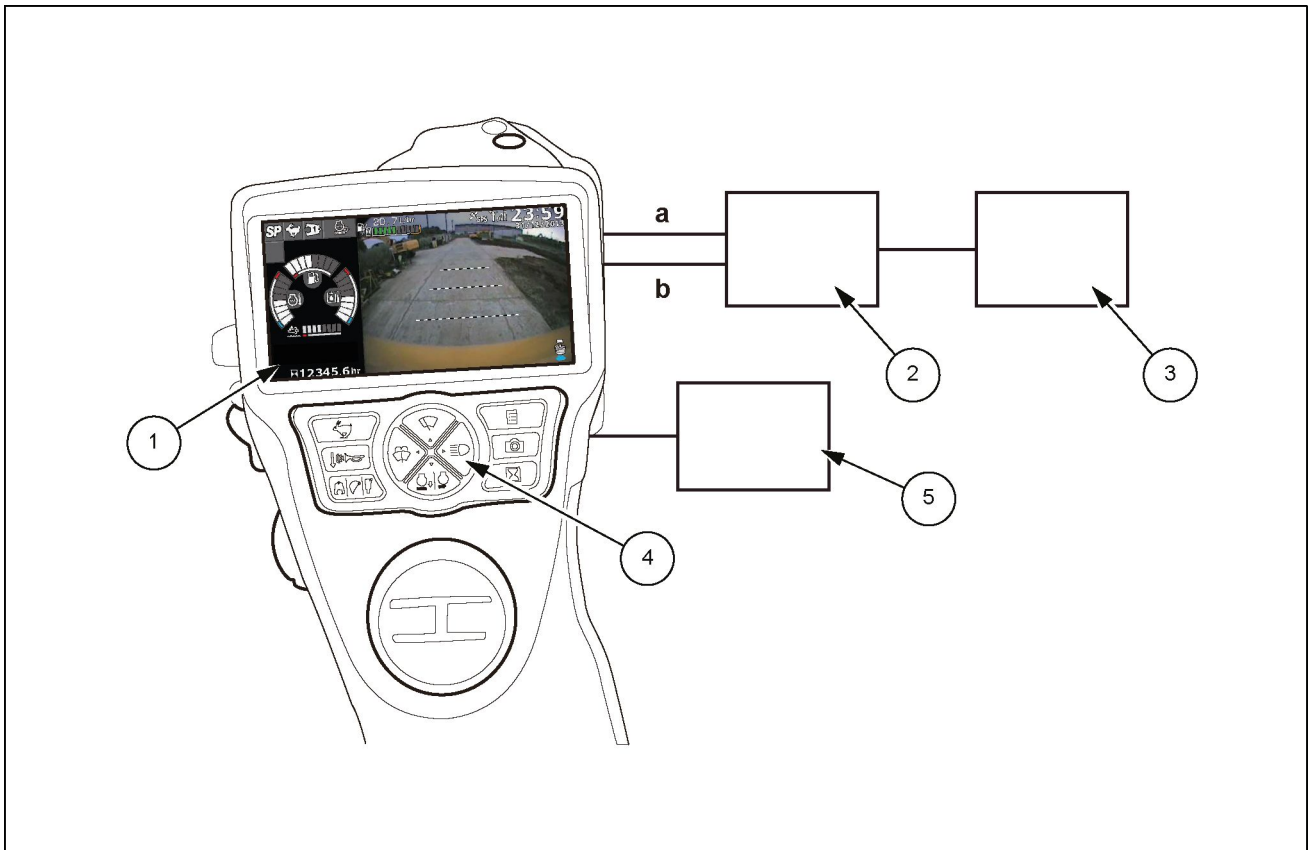

SMIL14CEX3418FB 1

- | | |
|---------------------------|---|
| 1. Monitor | 5. Working light relay |
| 2. Main controller | a. Dimming level automatic adjustment by solar radiation sensor |
| 3. Solar radiation sensor | b. Working light linked dimming by working light relay |
| 4. Working light switch | |

QUICK COUPLER

Purpose/overview

This is a device for one-touch replacement of the end attachment.

While the switch is pressed, a buzzer sounds and the coupler is unlocked. When the coupler switch is released, the coupler will be locked automatically.

Configuration

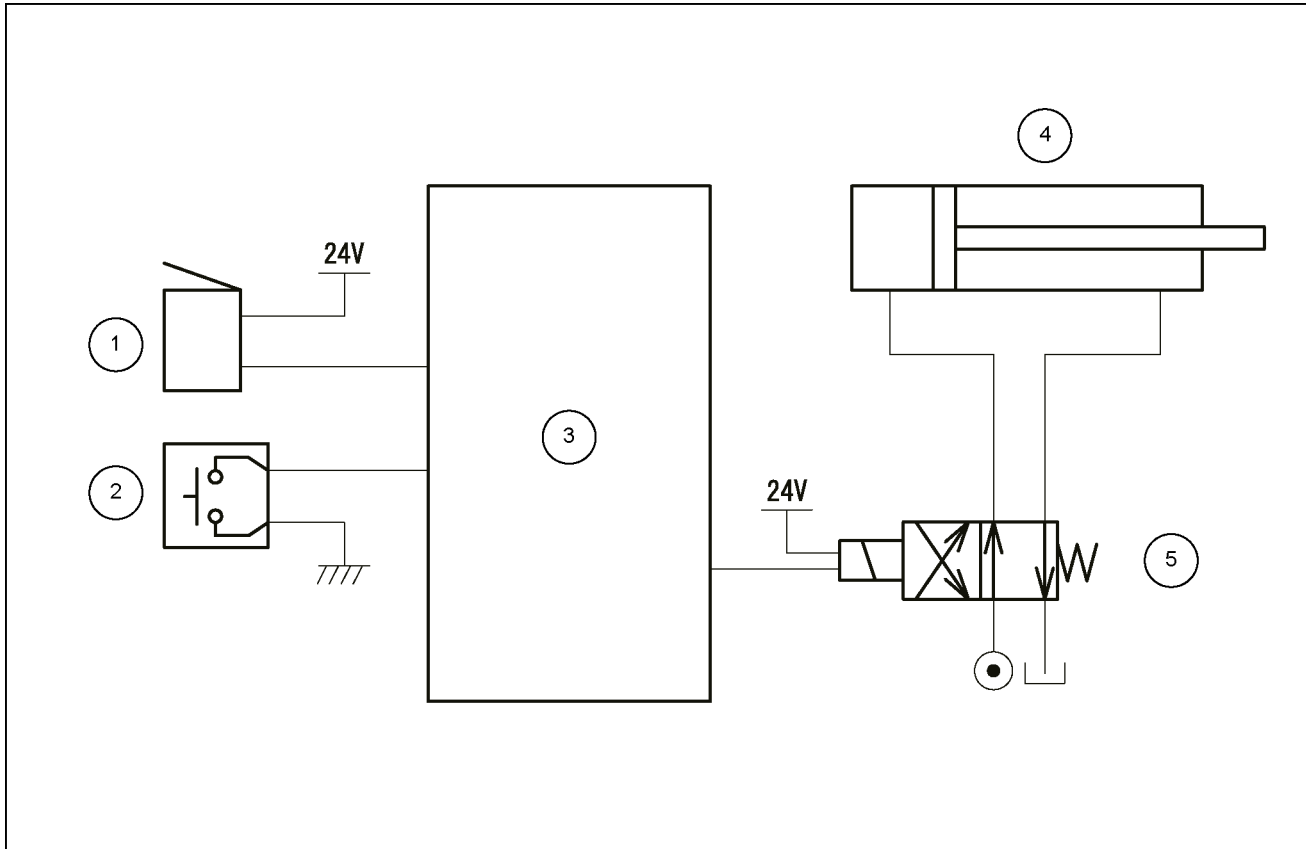

SMIL14CEX0903FB 8

- | | | | |
|----|----------------------|----|------------------------|
| 1. | Quick coupler buzzer | 4. | Coupler cylinder |
| 2. | Quick coupler switch | 5. | Coupler solenoid valve |
| 3. | Main controller | | |

Control

- When the solenoid valve is OFF, pilot pressure is supplied to the bottom side of the coupler cylinder to force the coupler into a locked state.
- When the solenoid valve is ON, pilot pressure is supplied to the rod side of the coupler cylinder to unlock the coupler.

Operation condition

- While the coupler switch is pressed, a buzzer sounds and the solenoid valve turns ON. Then, pilot pressure is supplied to unlock the coupler.
- Only when the coupler switch is set from OFF to ON, the solenoid valve and a buzzer will be activated. They will not be activated if the coupler switch has been ON since the key was turned ON.
- If a buzzer disconnection is detected, the coupler solenoid valve will not be activated (fixed at OFF) even when the coupler switch is pressed.

Air-conditioning system pressure switch - Static description

Dual pressure switch

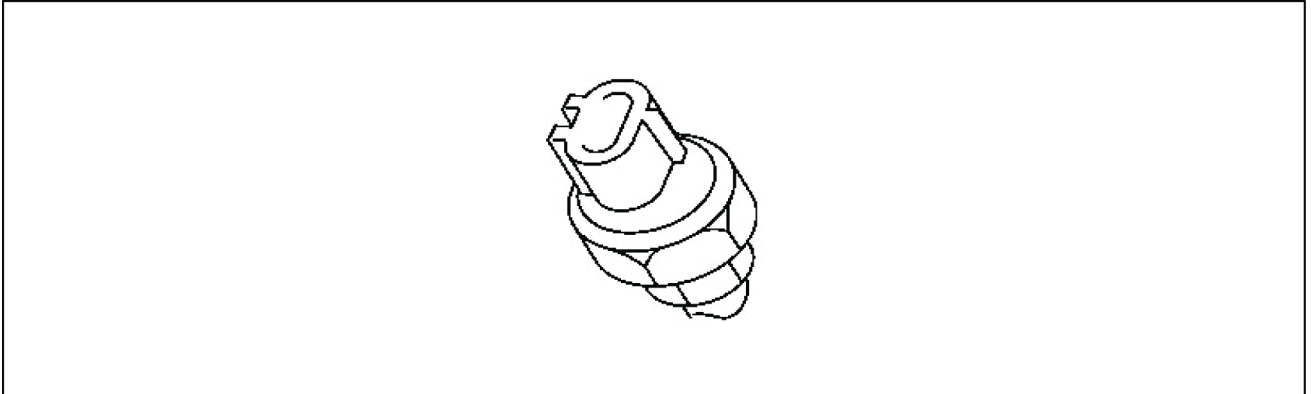

LPIL12CX02362EA 1

The dual pressure switch is installed on the receiver dryer. When there is pressure trouble in the coolant high-pressure side line (abnormally high pressure or abnormally low pressure), the dual pressure switch contacts open up to cut off the compressor power and protect the cooling cycle.

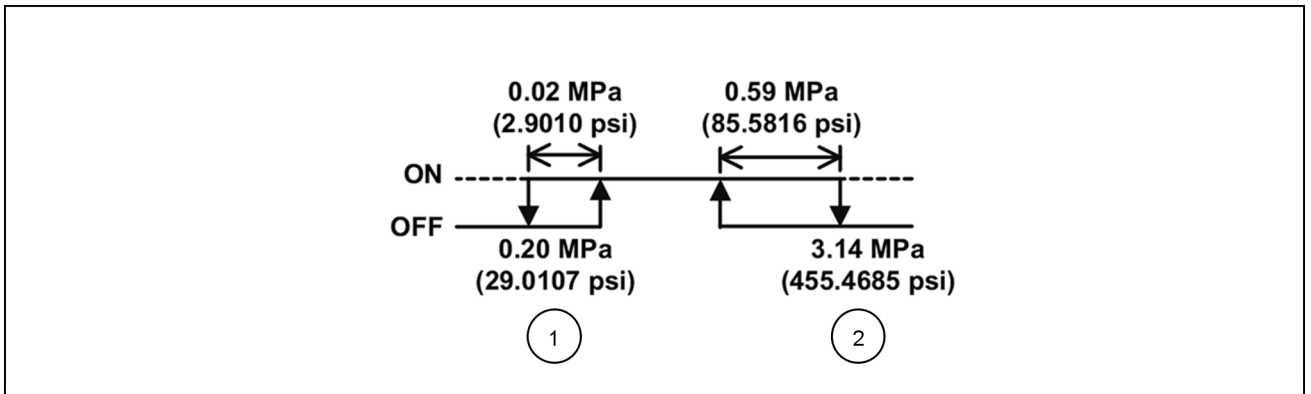

SMPH14CEX6783EB 2

Dual pressure switch specifications

1	Lower-pressure side
2	High-pressure side

Simple inspection method for dual pressure switch.

1. With the cooling cycle stopped, remove the connector from the switch and check for continuity between the switch side connector terminals using the tester. If there is continuity, the switch is normal. (When the outside air temperature is **0 °C (32 °F)** or higher)
2. Connect the gauge manifold high-pressure side hose to the high-pressure side charge port. With the cooling cycle operating, the condenser front surface is covered with a plate shaped object and the high pressure rises. If the compressor stops around **3.14 MPa (455.457 psi)**, the switch is normal.
3. With the refrigerant removed, check for continuity between the switch side connector terminals using the tester. If there is no continuity, the switch is normal.

Camera - Install - Field View Monitor (FVM) controller

1. To install, perform the reverse of the removal procedure.
If the FVM controller is replaced, set up the FVM.
Refer to **Camera - Configure (55.530)**.

Warning indicators, alarms, and instruments - Inspect

Monitor warning light lighting circuit system

Functions

The monitor is supplied with power supply voltage via the starter switch and shows an abnormality display due to a signal from the ECM.

The ECM makes the monitor show an abnormality display during a lamp check when the starter switch is ON and when the DTC is set.

It also blinks the monitor depending on the detected DTC when the body ground terminal and diagnostic switch terminal of the DLC are shorted.

A monitor circuit is incorporated inside the ECM and monitors operation of the light.

Inspection

Inspection if the monitor does not show an abnormality display when the starter switch is switched ON

1. Perform the OBD system check.
2. Inspect the monitor bulb.
3. Replace the valve if a problem is discovered.
4. Inspect the monitor circuit.
 - No open circuit or high resistance should be found between the fuse and monitor.
 - No open circuit or high resistance should be found between the monitor and ECM.
5. Repair the circuit if a problem is discovered.
6. Replace the ECM.
7. After replacing the ECM, perform EGR learning.

Monitor warning light blinking circuit system

Functions

The monitor is supplied with power supply voltage via the starter switch and shows an abnormality display due to a signal from the ECM.

The ECM makes the monitor show an abnormality display during a lamp check when the starter switch is ON and when the DTC is set.

It also blinks the monitor depending on the detected DTC when the body ground terminal and diagnostic switch terminal of the DLC are shorted.

A monitor circuit is incorporated inside the ECM and monitors operation of the warning light.

Inspection

Inspection if the monitor continues showing an abnormality display and does not flash when the diagnostic switch is switched ON

7065-Boom-up pilot pressure sensor signal abnormality

Control Module : MCM

Solution:

1. Use the below image for the fault code resolution process:

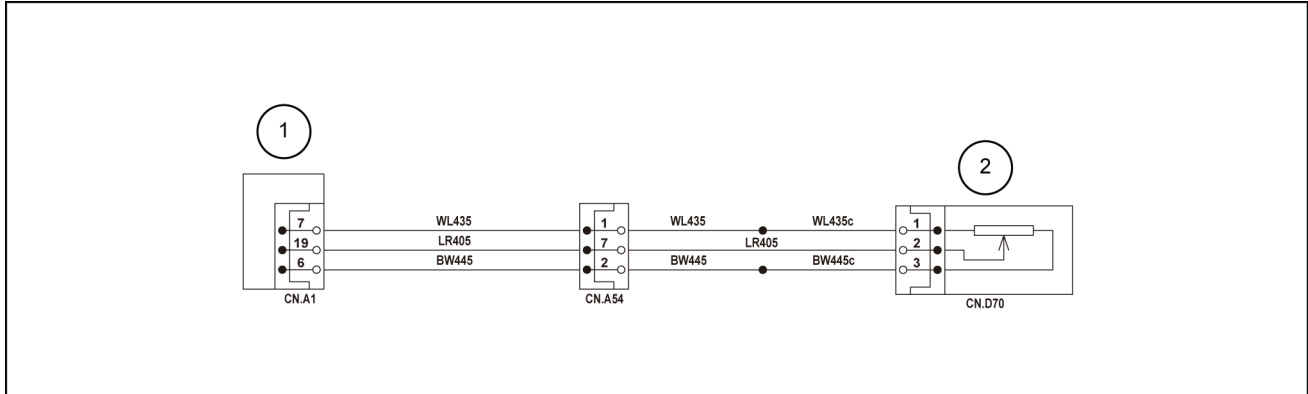

SMIL15CEX1879EB 1

1. Main controller
2. Pressure sensor (boom up pilot)

Turn the key switch ON.

Inspect the connection status of each connector. Make sure that all the connectors are secured.

A. If diagnostic trouble code 7065 is displayed, proceed to Step 2.

2. Check the boom up pilot pressure sensor (2) voltage on the service support screen.

A. If the voltage is more than or equal to **4.75 V**, proceed to Step 3.

B. If the voltage is less than or equal to **0.25 V**, proceed to Step 6.

3. Turn the key switch OFF and disconnect the boom up pilot pressure sensor (2) (3-pin) connector **CN.D70**.

Turn the key switch ON.

Measure the voltage between the ground and terminal 1 of the boom up pilot pressure sensor (2) (3-pin) **CN.D70** (harness side).

A. If the voltage is not about **5 V**, find and replace the short circuit on the wire ID WL435c and WL435.

B. If the voltage is about **5 V**, proceed to Step 4.

4. Measure the voltage between the ground and terminal 2 of the boom up pilot pressure sensor (2) (3-pin) **CN.D70** (harness side).

A. If the voltage is more than **4.75 V**, find and replace the short circuit on the wire ID LR405.

B. If the voltage is less than or equal to **4.75 V**, proceed to Step 5.

5. Measure the voltage between the ground and terminal 3 of the boom up pilot pressure sensor (2) (3-pin) **CN.D70** (harness side).

A. If the voltage is more than **0.25 V**, find and replace the short circuit on the wire ID BW445c and BW445.

B. If the voltage is less than or equal to **0.25 V**, replace the main controller (1).

6. Inspect the boom up pilot pressure sensor (2).

Turn the key switch OFF.

7265-Arm 1 Semi-Parallel Proportional Valve Abnormality

Control Module : MCM

Solution:

1. Use the below image for the fault code resolution process:

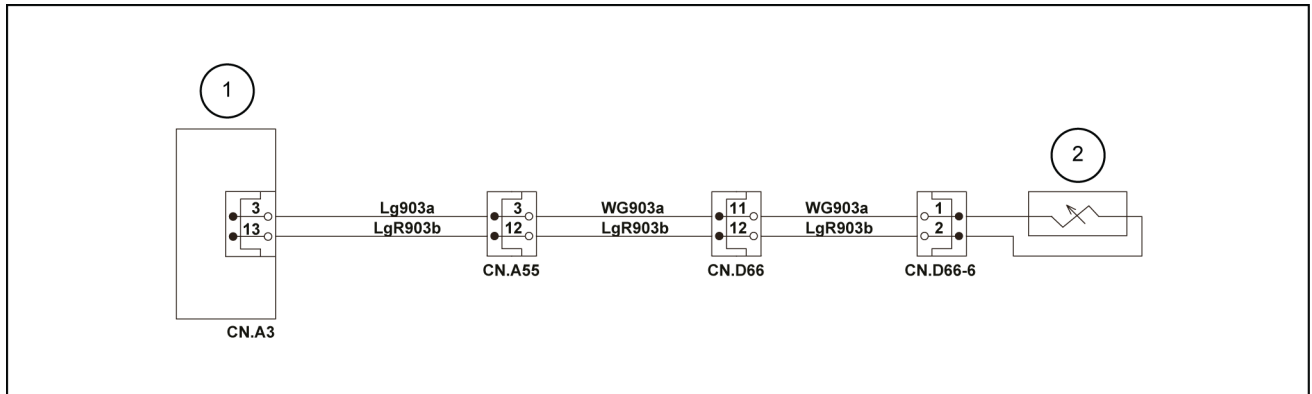

SML14CEX3621EB 1

1. Main controller
2. Proportional valve (arm 1 parallel)

Turn the key switch ON.

A. If diagnostic trouble code 7265 is displayed, proceed to Step 2.

2. Turn the key switch OFF.

Inspect the connectivity of each connector for poor insertion and wiring terminal disconnection.

Disconnect each connector, and check for any wiring terminal abnormality. If there is no abnormality, reconnect the connectors.

Turn the key switch ON.

A. If the diagnostic trouble code: 7265 is displayed, proceed to Step 3.

3. Reset the diagnostic trouble code at the service support screen.

A. If the diagnostic trouble code: 7265 is displayed, proceed to Step 4

B. If the diagnostic trouble code: 7265 is not displayed, proceed to Step 5

4. Turn the key switch OFF.

Inspect for continuity between the ground and terminal 1 of the connector **CN.D66-6** harness side.

A. If there is continuity, Replace or repair the WG903a and Lg903a harnesses.

B. If there is no continuity, Replace the main controller (1).

5. Turn the key switch OFF.

Remove the **CN.D66-6**.

Inspect for continuity between the terminals 1 and 2 of the connector **CN.D66-6** proportional valve side.

A. If there is continuity, proceed to Step 6.

B. If there is no continuity, replace the proportional valve (2).

6. Remove the **CN.A3**.

- B. If there is continuity, proceed to Step**5**.
- 5. Turn the key switch ON.
 - A. If diagnostic trouble code 7621 is not displayed, replace the air conditioner panel **(2)**.
 - B. If diagnostic trouble code 7621 is displayed, replace the main controller **(1)**.

P0182-Fuel temperature sensor, low input

Control Module : ECM

Solution:

1. Check and diagnose the below fault code before you proceed with the diagnostic code P0182.

Diagnostic trouble code P06A9

2. Turn OFF the ignition switch.

Disconnect the harness connector **CN.E9** from the fuel temperature sensor.

Observe the fuel temperature sensor display on the trouble diagnosis scan tool.

A. If the reading is more than or equal to the **4.5 V**, replace the fuel temperature sensor. (Refer to “**High pressure pump - Remove (10.218)** and **High pressure pump - Install (10.218)**”)

B. If the reading is less than **4.5 V**, proceed to Step 3.

NOTE: Do not replace the fuel temperature sensor separately. If a problem is found, replace the fuel supply pump

3. Inspect to see if there is a short circuit to the GND with the signal circuit between the ECM and fuel temperature sensor.

A. If a problem is found, repair the signal circuit.

B. If there are no problems, proceed to Step 4

4. Inspect the ECM harness connector **CN.D4** for a poor connection.

A. If a problem is found, repair the harness connector **CN.D4**.

B. If the harness connector **CN.D4** is normal, replace the ECM. (Refer to “**Engine Control Unit (ECU) - Remove (55.015)** and **Engine Control Unit (ECU) - Install (55.015)**”)

5. Set the Injector ID Code, fuel delivery rate and engine No. for the ECM.

6. Confirm resolution:

1. Clear the diagnostic trouble code using the trouble diagnosis scan tool.

2. Turn OFF the ignition switch for at least **30 s**.

3. Start the engine.

4. Perform a test-run under the conditions for running the diagnostic trouble code.

NOTE:

- Conditions for setting engine run time or coolant temperature vary depending on the diagnostic trouble codes.
- For the conditions for setting the diagnostic trouble code, refer to the applicable code listed in 15E diagnostic trouble code information.

5. Use the trouble diagnosis scan tool to confirm that a diagnostic trouble code has not been detected.

Wiring harnesses - Electrical schematic sheet 20 (55.100) Wiring harnesses - Electrical schematic sheet 15 (55.100)

P041D-EGR cooler outlet 1 temperature sensor circuit high

Control Module : ECM

Solution:

1. Check and diagnose the below fault codes before you proceed with the diagnostics code P041D.
Diagnostic trouble code P06A8
 2. Turn OFF the ignition switch.
Disconnect the harness connector **CN.E13** from EGR gas temperature sensor 2.
Turn ON the ignition switch.
Measure the voltage between the EGR gas temperature sensor 2 signal circuit and a known good GND.
 - A. If the reading is more than or equal to **5.5 V**, inspect the signal circuit between the ECM and EGR gas temperature sensor 2 for a short to the battery or a short to the ignition power supply.
 - B. If a problem is found, repair the signal circuit.
 - C. If there are no problems, proceed to Step 3
 3. Connect a fused jumper wire between the EGR gas temperature sensor 2 signal circuit and the GND circuit.
Observe the **5 V** adjustment display of EGR gas temperature sensor 2 on the trouble diagnosis scan tool.
 - A. If the reading is less than or equal to **0.1 V**, inspect the signal circuit between the ECM and the EGR gas temperature sensor for a short to the **5 V** power supply circuit.
 - B. If a problem is found, repair the signal circuit.
 - C. If there are no problems, proceed to Step 4
 4. Inspect for poor connections at the EGR gas temperature sensor 2 harness connector **CN.E13**.
 - A. If a problem is found, repair the harness connector **CN.E13**.
 - B. If the harness connector **CN.E13** is normal, replace EGR gas temperature sensor 2. (Refer to “**Exhaust Gas Recirculation (EGR) temperature sensors - Remove - Temperature sensor 2 (55.989)** and **Exhaust Gas Recirculation (EGR) temperature sensors - Install - Temperature sensor 2 (55.989)**”)
 - C. If there are no problems, proceed to Step 5
 5. Connect a fused jumper wire between the EGR gas temperature sensor 2 signal circuit and a known good GND.
Observe the **5 V** adjustment display of EGR gas temperature sensor 2 on the trouble diagnosis scan tool.
 - A. If the reading is less than or equal to **0.1 V**, inspect the EGR gas temperature sensor 2 GND circuit for an open circuit or high resistance.
 - B. If a problem is found, repair the GND circuit.
 - C. If there are no problems, proceed to Step 6
- NOTE:**
- EGR gas temperature sensor 2 shares the GND circuit with other sensors.
 - Diagnostic trouble codes on sensors that share this circuit may be set.
6. Inspect the EGR gas temperature sensor 2 signal circuit for an open circuit or high resistance.
 - A. If a problem is found, repair the signal circuit.
 - B. If there are no problems, proceed to Step 7

P0687-ECM power relay control circuit high

Control Module : ECM

Solution:

1. Turn OFF the ignition switch.

Remove the main relay.

Turn ON the ignition switch.

Use the trouble diagnosis scan tool to see if diagnostic trouble code P0685 is detected.

- A. If the diagnostic trouble code P0685 is not detected, repair the short circuit to the battery power supply of the power supply circuit between the ECM and main relay.
 - B. If the diagnostic trouble code P0685 is detected, proceed to Step 2.
2. Turn OFF the ignition switch for at least **30 s**.

Replace the main relay with a glow relay or normal relay.

Turn ON the ignition switch.

Use the trouble diagnosis scan tool to check if diagnostic trouble code P0687 has been detected.

- A. If the diagnostic trouble code P0687 is not detected, replace the main relay.
3. Confirm resolution:
 1. Clear the diagnostic trouble code using the trouble diagnosis scan tool.
 2. Turn OFF the ignition switch for at least **30 s**.
 3. Turn ON the ignition switch.
 4. Use the trouble diagnosis scan tool to confirm that a diagnostic trouble code has not been detected.

f. Measure 2 - 3 times at different temperatures and check whether the temperature difference is less than or equal to the **5 °C (41 °F)**.

A. If the temperature difference is more than or equal to **5 °C (9 °F)**, replace the urea fluid sensor.

5. Confirm resolution:

1. Clear the diagnostic trouble code using the trouble diagnosis scan tool.

NOTE:

- *After clearing the DCU diagnostic trouble code, observe whether ECM diagnostic trouble code P20C9 is set.*
- *If diagnostic trouble code P20C9 is set, clear it.*

2. Turn OFF the ignition switch until communication with the trouble diagnosis scan tool is discontinued.

3. Turn ON the ignition switch without starting the engine.

4. Observe the diagnostic trouble code information with the trouble diagnosis scan tool. A diagnostic trouble code should not be set.

Wiring harnesses - Electrical schematic sheet 21 (55.100)

P208A-Urea fluid pump control circuit

Control Module : DCU

Solution:

1. Turn OFF the ignition switch.

Disconnect the urea fluid supply module harness connector **CN.D38**.

Inspect the urea fluid supply module harness connector **CN.D38**.

NOTE:

- Make sure that there is no intermittent conditions, poor connections, or corrosion for any of the terminals.
- Make sure that there is no open circuit, high resistance, or short to any of the circuits.
- Make sure that there is no water intrusion or adhering foreign material.

A. If a problem is found, repair the connector **CN.D38**.

B. If there are no problems, proceed to Step 2

2. Turn OFF the ignition switch.

Disconnect the DCU harness connector **CN.D1-D2**.

Inspect the DCU harness connector **CN.D1-D2**.

NOTE:

- Make sure that there is no intermittent conditions, poor connections, or corrosion.
- Make sure that there is no water intrusion or adhering foreign material.

A. If a problem is found, repair the connector **CN.D1-D2**.

B. If there are no problems, proceed to Step 3

3. Inspect the urea fluid pump power supply circuit between the DCU and the urea fluid supply module harness connector for an open circuit or high resistance.

A. If a problem is found, repair the pump power supply circuit.

B. If there are no problems, proceed to Step 4

4. Inspect the GND circuit between the DCU and the urea fluid supply module harness connector **CN.D38** for an open circuit or high resistance

A. If a problem is found, repair the GND circuit.

B. If there are no problems, proceed to Step 4

5. Inspect the pump control circuit between the DCU and the urea fluid supply module harness connector **CN.D38** for an open circuit.

A. If a problem is found, repair the pump control circuit.

B. If there are no problems, replace the urea fluid supply module. (Refer to “ **Diesel Exhaust Fluid (DEF)/AdBlue® supply module - Remove (55.988)** and **Diesel Exhaust Fluid (DEF)/AdBlue® supply module - Install (55.988)**”)

6. Replace the DCU. (Refer to “ **Dosing control unit - Remove (55.988)** and **Dosing control unit - Install (55.988)**”)

7. Confirm resolution:

1. Clear the diagnostic trouble code using the trouble diagnosis scan tool.

NOTE:

- After clearing the DCU diagnostic trouble code, observe whether ECM diagnostic trouble code P20C9 is set.
- If diagnostic trouble code P20C9 is set, clear it.

P2122-Pedal position sensor 1 circuit low input

Control Module : ECM

Solution:

1. Check and diagnose the below fault codes before you proceed with the diagnostics code P2122.
Diagnostic trouble code P06A6
2. Turn OFF the ignition switch.
Disconnect the harness connector **CN.B2** from the accelerator position sensor.
Turn ON the ignition switch.
Measure the voltage between the **5 V** power supply circuit and GND of the accelerator position sensor.
 - A. If the reading is less than or equal to the **4.5 V**, inspect to see if there is an open circuit or high resistance with the **5 V** power supply circuit between the ECM and the accelerator position sensor.
 - B. If a problem is found, repair the **5 V** power supply circuit.
 - C. If there are no problems, proceed to Step 3
3. Connect the test cable with fuse between the **5 V** power supply circuit and sensor 1 signal circuit of the accelerator position sensor.
Observe the accelerator pedal sensor 1 display on the trouble diagnosis scan tool.
 - A. If the reading is more than or equal to the **4.5 V**, inspect to see if there is a poor connection with the accelerator position sensor harness connector **CN.B2**.
 - B. If a problem is found, repair the harness connector **CN.B2**.
 - C. If the harness connector **CN.B2** is normal, replace the accelerator position sensor.
 - D. If there are no problems, proceed to Step 4
4. If the reading is less than or equal to the **4.5 V**, inspect the sensor 1 signal circuit between the ECM and accelerator position sensor.
Make sure that there should be no open circuit or high resistance.
Make sure that there should be no short to GND.
 - A. If a problem is found, repair the sensor 1 signal circuit.
 - B. If there are no problems, proceed to Step 5
5. Inspect the ECM harness connector **CN.A1** for a poor connection.
 - A. If a problem is found, repair the harness connector **CN.A1**.
 - B. If the harness connector **CN.A1** is normal, replace the ECM. (Refer to “ **Engine Control Unit (ECU) - Remove (55.015)** and **Engine Control Unit (ECU) - Install (55.015)**”)
6. Set the Injector ID Code, fuel delivery rate and engine No. for the ECM.
7. Confirm resolution:
 1. Clear the diagnostic trouble code using the trouble diagnosis scan tool.
 2. Turn OFF the ignition switch for at least **30 s**.
 3. Start the engine and fully depress and release the accelerator pedal while observing the accelerator pedal sensor 1 display on the trouble diagnosis scan tool.

U0073-CAN-Bus Malfunction

Control Module : ECM

Solution:

1. Check and diagnose the below fault codes before you proceed with the diagnostics code U0073.
2. Turn OFF the ignition switch.

Measure the resistance between the terminals of the termination resistor harness connector **CN.D90-2**.

NOTE:

- Make a measurement from the back with the harness connector connected.
- Confirm that the parallel resistance of the **120 Ω** resistor in the termination resistor and that of the **120 Ω** resistor in the ECM are both **60 Ω**.

Disconnect the harness connector **CN.D90-2** from termination resistor if the resistance value is outside the **50 - 70 Ω**

Measure the resistance of the termination resistor.

- A. If the resistance value is outside the **110 - 130 Ω**, replace the termination resistor.
 - B. If there are no problems, proceed to Step 3
3. Connect the harness connector **CN.D90-2** to the termination resistor.

Disconnect the harness connector **CN.A4** from the control unit of the machine.

Measure the resistance between the terminals of the termination resistor harness connector.

NOTE: Make a measurement from the back with the harness connector connected.

- A. If the resistance value is within the **50 - 70 Ω**, replace the control unit of the machine.
 - B. If there are no problems, proceed to Step 4
4. Disconnect the harness connector **CN.D3** from the ECM.

Measure the resistance between the terminals of the termination resistor harness connector.

NOTE: Make a measurement from the back with the harness connector connected.

If the resistance value is within the range of **110 - 130 Ω**, replace the ECM. (Refer to “**Engine Control Unit (ECU) - Remove (55.015)** and **Engine Control Unit (ECU) - Install (55.015)**”)

Set the injector ID Code on the ECM.

Set the engine No. for the ECM.

Turn OFF the ignition switch.

Disconnect the harness connector **CN.A4** from the control unit of the machine or **CN.D3** ECM.

Inspect the CAN-Low circuit and the CAN-High circuit between each control unit.

- Make sure that there is no short to the battery or the ignition power supply.
- Make sure that there is no open circuit or high resistance.
- Make sure that there is no short to GND.

A. If the CAN circuit is normal, turn OFF the ignition switch.

B. If there are no problems, proceed to Step 5

11. Bucket and arm installation section

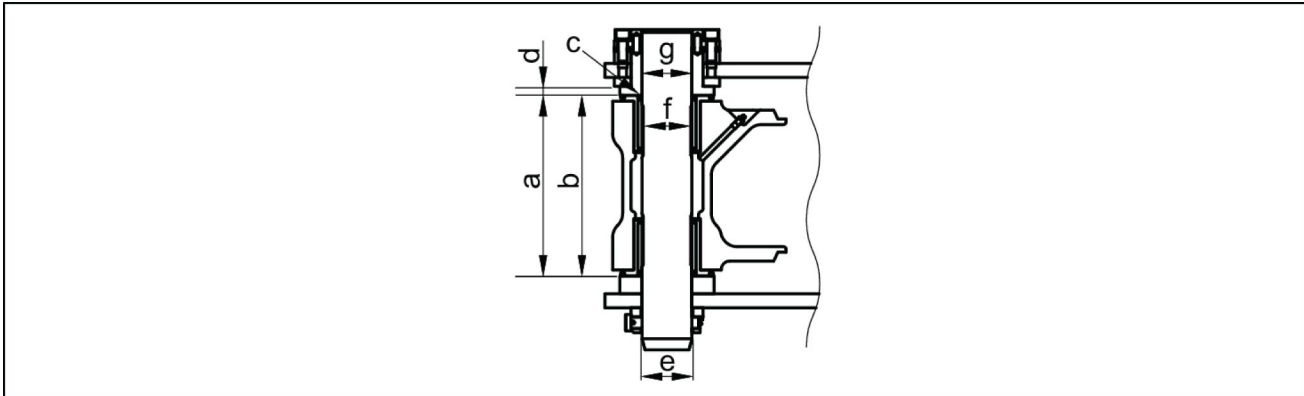

SMIL13CEX2719EA 12

Part name	Code	Standard value	Usage limits	Judgment	Solution
Bucket	a	307 mm (12.09 in)	313 mm (12.32 in)	Acceptable/ Unacceptable	Replacement
Arm	b	306 mm (12.05 in)	304 mm (11.97 in)	Acceptable/ Unacceptable	Replacement
Clearance	c	0.7 - 3.8 mm (0.03 - 0.15 in)	Shim adjustment	Acceptable/ Unacceptable	Adjustment with shims
Bushing (bucket)	d	16 mm (0.63 in)	8 mm (0.31 in)	Acceptable/ Unacceptable	Replacement
Pin	e	Ø 80 mm (3.15 in)	Ø 79 mm (3.11 in)	Acceptable/ Unacceptable	Replacement
Bushing (arm)	f	Ø 80 mm (3.15 in)	Ø 81.5 mm (3.21 in)	Acceptable/ Unacceptable	Replacement
Bushing (bucket)	g	Ø 80 mm (3.15 in)	Ø 81.5 mm (3.21 in)	Acceptable/ Unacceptable	Replacement

5. Bucket pin (connection between bucket and bucket link)

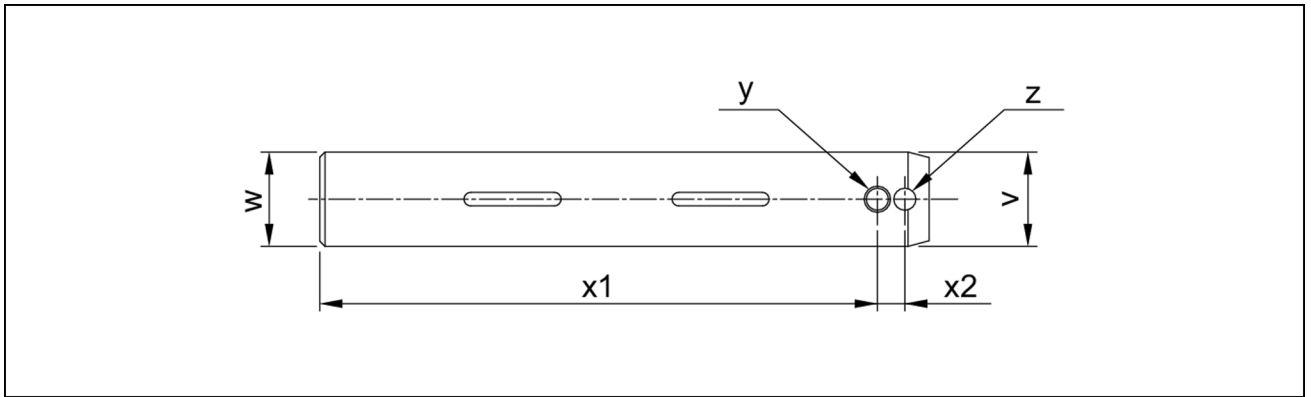

SMIL15CEX0336EB 5

Part	v	w	x1	x2	y	z
Dimension	65 mm (2.559 in)	65 mm (2.559 in)	373 mm (14.685 in)	22 mm (0.866 in)	Ø 17 mm (0.669 in)	Ø 13 mm (0.512 in)

CLICK HERE TO **DOWNLOAD** THE COMPLETE MANUAL

- Thank you very much for reading the preview of the manual.
- You can download the complete manual from: www.heydownloads.com by clicking the link below



- Please note: If there is no response to CLICKING the link, please download this PDF first and then click on it.

CLICK HERE TO **DOWNLOAD** THE COMPLETE MANUAL