

SERVICE MANUAL

Cursor[®] I3 Single Stage Turbocharger Tier 4B (final) and Stage IV Engine

See the following page for engine model numbers

CLICK HERE TO **DOWNLOAD** THE COMPLETE MANUAL

- Thank you very much for reading the preview of the manual.
- You can download the complete manual from: www.heydownloads.com by clicking the link below



- Please note: If there is no response to CLICKING the link, please download this PDF first and then click on it.

CLICK HERE TO **DOWNLOAD** THE COMPLETE MANUAL

Torque - Minimum tightening torques for normal assembly

METRIC NON-FLANGED HARDWARE

NOM. SIZE	CLASS 8.8 BOLT and CLASS 8 NUT		CLASS 10.9 BOLT and CLASS 10 NUT		LOCKNUT CL.8 W/CL8.8 BOLT	LOCKNUT CL.10 W/CL10.9 BOLT
	UNPLATED	PLATED W/ZnCr	UNPLATED	PLATED W/ZnCr		
M4	2.2 N·m (19 lb in)	2.9 N·m (26 lb in)	3.2 N·m (28 lb in)	4.2 N·m (37 lb in)	2 N·m (18 lb in)	2.9 N·m (26 lb in)
M5	4.5 N·m (40 lb in)	5.9 N·m (52 lb in)	6.4 N·m (57 lb in)	8.5 N·m (75 lb in)	4 N·m (36 lb in)	5.8 N·m (51 lb in)
M6	7.5 N·m (66 lb in)	10 N·m (89 lb in)	11 N·m (96 lb in)	15 N·m (128 lb in)	6.8 N·m (60 lb in)	10 N·m (89 lb in)
M8	18 N·m (163 lb in)	25 N·m (217 lb in)	26 N·m (234 lb in)	35 N·m (311 lb in)	17 N·m (151 lb in)	24 N·m (212 lb in)
M10	37 N·m (27 lb ft)	49 N·m (36 lb ft)	52 N·m (38 lb ft)	70 N·m (51 lb ft)	33 N·m (25 lb ft)	48 N·m (35 lb ft)
M12	64 N·m (47 lb ft)	85 N·m (63 lb ft)	91 N·m (67 lb ft)	121 N·m (90 lb ft)	58 N·m (43 lb ft)	83 N·m (61 lb ft)
M16	158 N·m (116 lb ft)	210 N·m (155 lb ft)	225 N·m (166 lb ft)	301 N·m (222 lb ft)	143 N·m (106 lb ft)	205 N·m (151 lb ft)
M20	319 N·m (235 lb ft)	425 N·m (313 lb ft)	440 N·m (325 lb ft)	587 N·m (433 lb ft)	290 N·m (214 lb ft)	400 N·m (295 lb ft)
M24	551 N·m (410 lb ft)	735 N·m (500 lb ft)	762 N·m (560 lb ft)	1016 N·m (750 lb ft)	501 N·m (370 lb ft)	693 N·m (510 lb ft)

NOTE: M4 through M8 hardware torque specifications are shown in pound-inches. M10 through M24 hardware torque specifications are shown in pound-feet.

Contents

Engine - 10

Engine and crankcase - 001

TECHNICAL DATA

Engine	
Service limits	3

SERVICE

Engine	
Service instruction - Finding Top Dead Center (TDC)	7
Crankcase	
Liner - Measure	9
Liner - Remove	13
Liner - Install	14
Liner - Measure Protrusion	15
Under block - Remove	16
Under block - Install	17

DIAGNOSTIC

Engine	
Troubleshooting	22

Engine - Troubleshooting

Problem	Possible Cause	Correction
Engine will not start	An engine no start is defined as an engine that will crank but will not start. The most likely causes of this failure are issues related to the battery, fuel system or low engine compression.	<ol style="list-style-type: none"> 1. Faulty battery, voltage too low. 2. Insufficient fuel level 3. Contaminated fuel (water or air) 4. Clogged fuel filter 5. Faulty fuel injectors 6. Faulty glow plugs (if equipped) 7. Faulty fuel lift pump (if equipped) 8. Faulty high pressure pump 9. Low engine compression 10. Engine timing incorrect
The engine starts then stalls	This symptom is usually caused by fuel leakage or a clogged fuel filter.	Visually inspect the fuel system for external leakage. If leakage is found, repair as necessary. Check fuel system pressure for adequate pressure. If fuel pressure is lower than expected, repair as necessary.
Engine will not crank	An engine no-crank condition is defined as an engine that will not crank. Possible failures include a dead or weak battery, an open battery disconnect switch (if equipped) or a starting system failure.	<ol style="list-style-type: none"> 1. Check battery voltage. Charge or replace the battery as necessary. 2. Verify the status of the battery disconnect switch (if equipped). The switch must be closed. 3. Check the starting system for possible failures. Check the starter relay and battery voltage at the starter. Perform a voltage drop test between the battery and the engine starter to check the starter wiring. Repair as necessary.
The engine is difficult to start	The cause of an engine hard start condition is similar to those of an engine no start condition. Failures can include inadequate fuel pressure, air supply, engine compression, faulty glow plugs or incorrect injection timing during start up.	<ol style="list-style-type: none"> 1. Faulty battery, voltage too low. 2. Insufficient fuel level 3. Contaminated fuel (water or air) 4. Clogged fuel filter 5. Faulty fuel injectors 6. Faulty glow plugs (if equipped) 7. Faulty fuel lift pump (if equipped) 8. Faulty high pressure pump 9. Restricted air induction system 10. Low engine compression 11. Engine timing incorrect
Engine has a slow cranking condition	A slow engine crank condition can be caused by a weak battery, worn starter internal engine resistance. Extremely cold operating temperatures can also be a factor in a slow engine crank condition.	<ol style="list-style-type: none"> 1. Load test the battery. Charge or replace the battery as necessary. 2. Perform a voltage drop test on the starting circuit. There should be a drop less than 0.5 V on both the positive and negative circuits. If the drop is greater than 0.5 V, repair as necessary. 3. Bench test the starter. If the starter operates slower than expected, replace the starter.

Cylinder head - Disassemble

Prior operation:

Cylinder head - Remove (10.101)

1. Install the tool **380000131 (9)** with bracket **(4)**.
2. Install the plate **380000112 (2)** then screw on the lever **(1)** for the tool **380000131** and compress the valve springs **(6)** until the keepers **(3)** are removed.
3. Loosen the lever **(1)** and remove the plate **(2)**.
4. Remove the upper plate **(5)**, the spring **(6)**, and the lower plate **(7)**. Repeat this operation for all cylinders.
5. Turn the cylinder head upside down and remove the valves **(8)**.

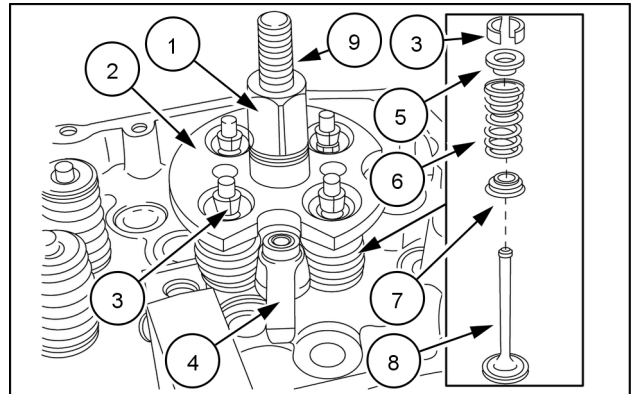

NHIL13ENG1244AA 1

Next operation:

Cylinder head - Assemble (10.101)

Contents

Engine - 10

Pan and covers - 102

SERVICE

Engine oil pan	
Remove	3
Install	4

Flywheel housing - Remove

Prior operation:

Engine flywheel - Remove (10.103)

1. Remove the screws (1) and pull off the flywheel housing (2).

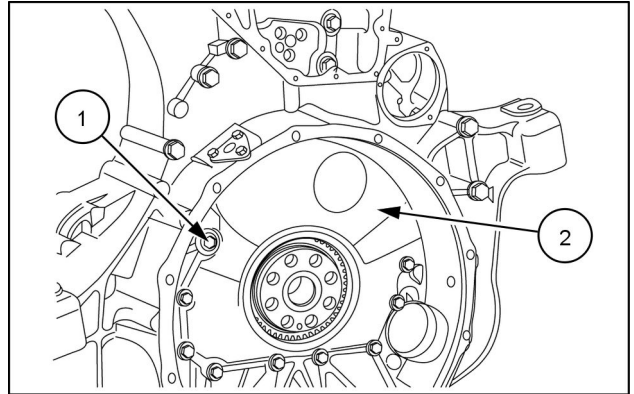

NHIL13ENG1173AA 1

Next operation:

Flywheel housing - Install (10.103)

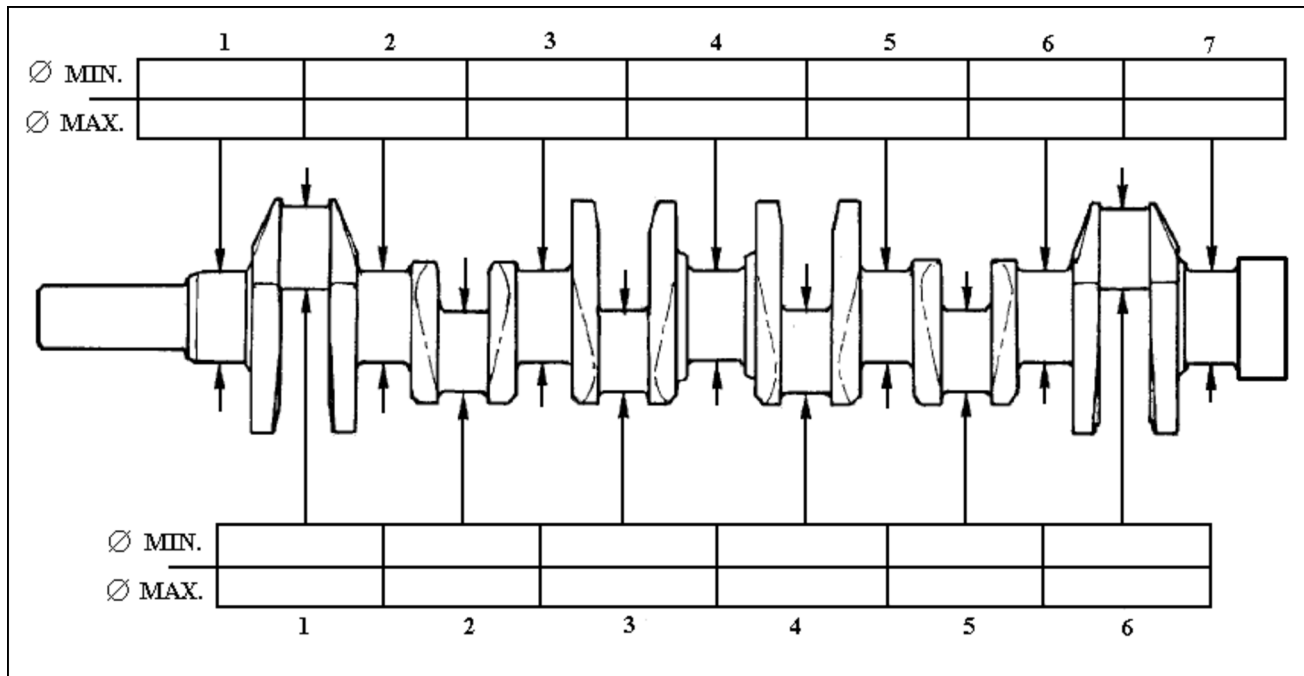

CRANKMEASURE5 7

Table for recording the measurements of the main journals and crankpins of the crankshaft.

Preliminary measurement of the main and big end bearing shell selection data

For the journals of the crankshaft, it is necessary to carry out the following operations

Main Journals:

- Determine the class of diameter of the seat in the crankcase.
- Determine the class of diameter of the main journal.
- Select the class of the bearing shells to mount.



Crankpins:

- Determine the class of diameter of the seat in the connection rod.
- Determine the class of diameter of the crankpin.
- Select the class of the bearing shell to mount.

Defining the class of diameter of the seats for bearing shells on the crankcase.

4. On the front of the crankcase, two sets of numbers are marked in the position shown in the figure below.
 - The first set of four digits is the coupling number of the crankcase with its base.
 - The following seven digits, taken individually, are the class of diameter of each of the seats.
 - Each of these digits may be (1), (2) or (3).

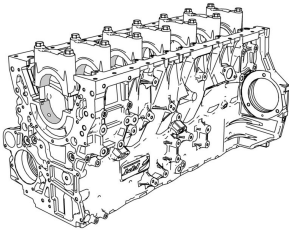
Bearing selection for an undersize crankshaft

<p>-0.127 mm (-0.005 in)</p>					
	Main journal diameter	Class	1	2	3
<p>92.843 - 92.853 mm (3.6552 - 3.6556 in)</p>	1	(U)	Green/Black	Green/Black	Yellow/Black*
		(L)	Green/Black	Yellow/Black*	Yellow/Black*
<p>92.853 - 92.863 mm (3.6556 - 3.6560 in)</p>	2	(U)	Red/Black	Green/Black	Green/Black
		(L)	Green/Black	Green/Black	Yellow/Black*
<p>92.863 - 92.872 mm (3.6560 - 3.6564 in)</p>	3	(U)	Red/Black	Red/Black	Green/Black
		(L)	Red/Black	Green/Black	Green/Black
<p>Red/Black = 3.031 - 3.041 mm (0.1193 - 0.1197 in) Green/Black = 3.041 - 3.051 mm (0.1197 - 0.1201 in) Yellow/Black* = 3.051 - 3.061 mm (0.1201 - 0.1205 in)</p>					
<p>* Production only. Substitute with Green/Black bearings if needed.</p>					

7. Verify the oil clearance is within the specifications below using plastic gauge. Refer to **Crankshaft Journal - Clearance (10.103)** for the proper procedure.
- Main journals: **0.050 - 0.090 mm (0.0020 - 0.0035 in)**
 - Crank pin journals: **0.040 - 0.080 mm (0.0016 - 0.0031 in)**

Contents

Engine - 10

Connecting rods and pistons - 105

FUNCTIONAL DATA

Connecting rod and piston	
Overview	3

SERVICE

Connecting rod and piston	
Remove	5
Disassemble	6
Connecting rod - Measure	7
Assemble	10
Install	11
Piston	
Measure	14
Pin - Measure	15
Ring - Measure	16

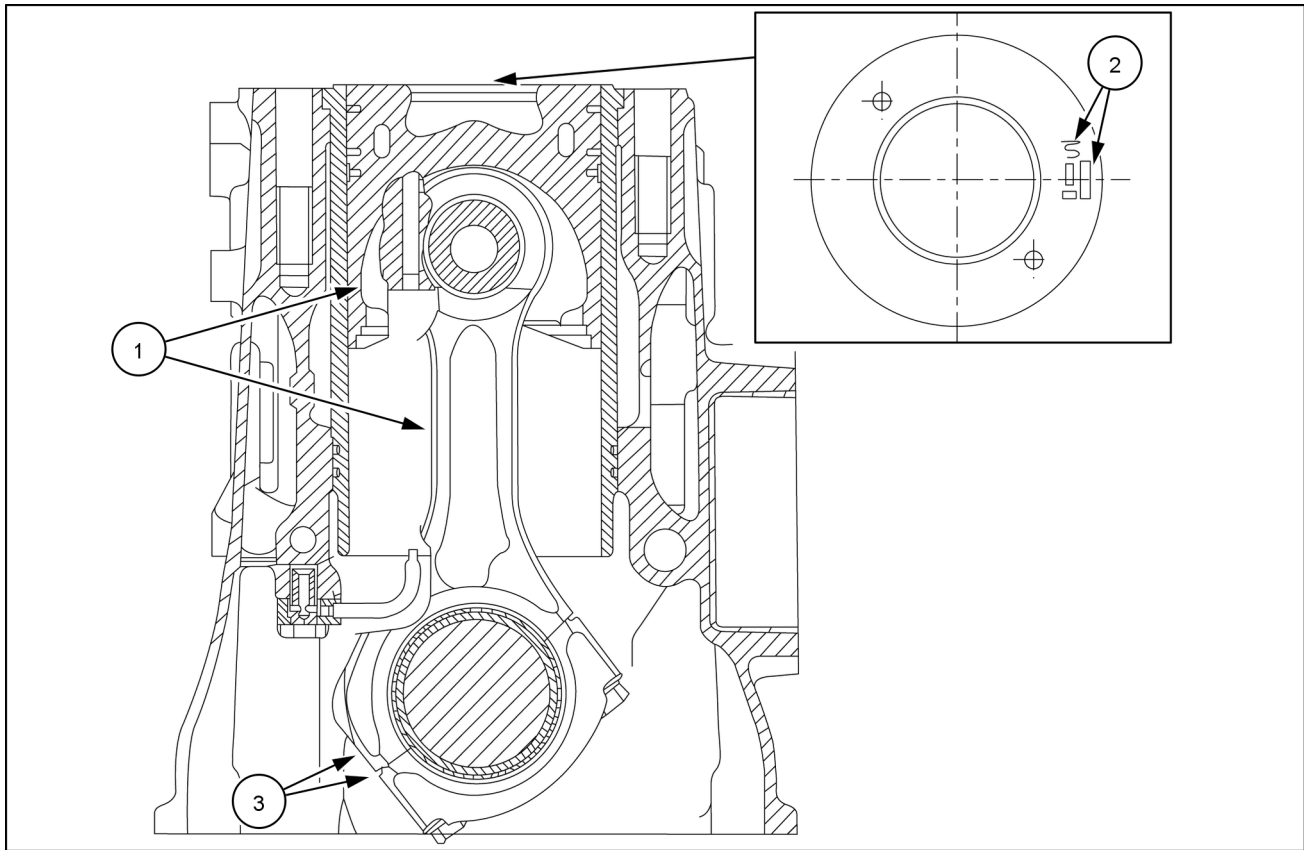

NHIL13ENG1318FA 3

(1) Connecting rod and piston assembly (2) Indication of assembly direction (3) Indication of cylinder number

3. The connecting rod cap screws may be reused providing the thread diameter (**d**) measured in zone (**L**) is at least **13.4 mm (0.528 in)**. Otherwise, replace the screw.
4. Lubricate the screws with engine oil before assembling.

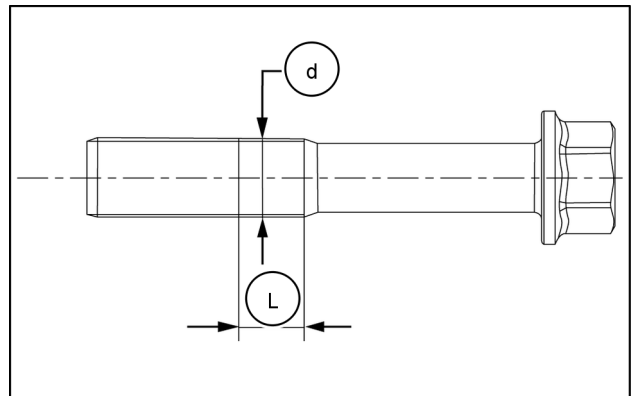

NHIL13ENG1152AA 4

5. Install the connecting rod caps (1) with the bearing halves.
6. Tighten the connecting rod cap screws (2) to **60 Nm (44 lb ft)** torque.
7. Using the tool **380001001 (3)**, tighten the screws an additional **60 °**.

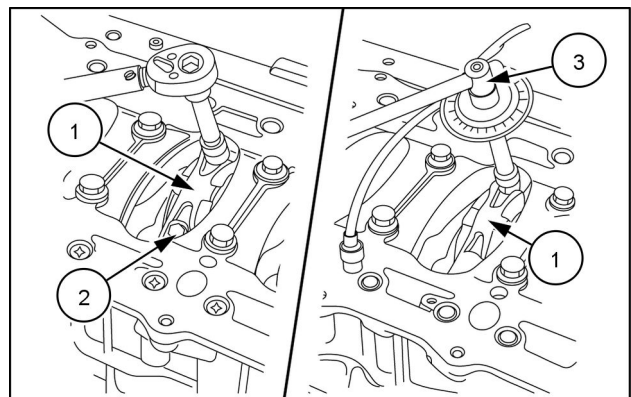

NHIL13ENG1158AA 5

Next operation:

Rocker arm - Install

Prior operation:

Rocker arm - Remove (10.106)

1. Set the cross-heads (1) on the valve stems.

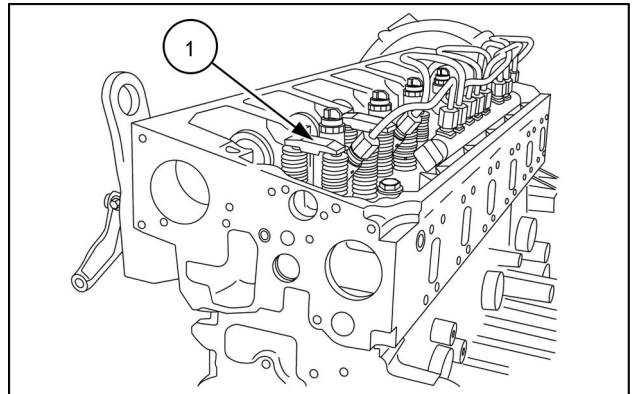

83116773 1

2. Loosen all adjusting screws on the rocker arms.
3. Apply the tool **380000148 (1)** to the rocker arm shaft and install the shaft on cylinder head.

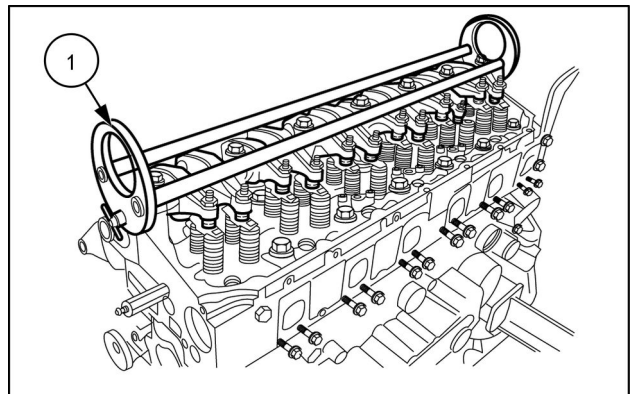

83116743 2

4. Torque the bolts to the specifications below and the sequence shown in the figure:

1. **25 N·m (18 lb ft)**
2. **60 N·m (44 lb ft)**
3. **80 N·m (59 lb ft)**
4. **60 °**

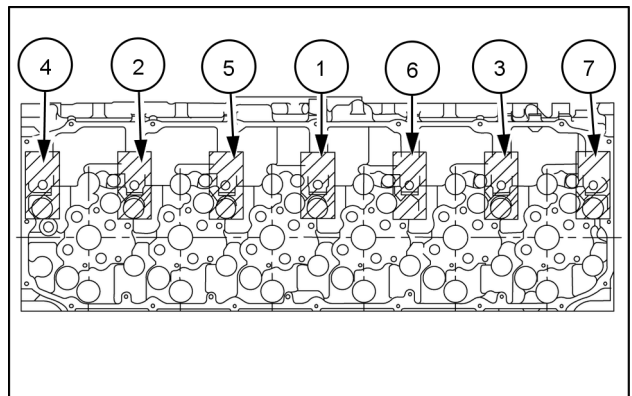

NHIL13ENG1224AA 3

Next operation:

Rocker arm - Adjust (10.106)

Common rail Relief valve - Overview

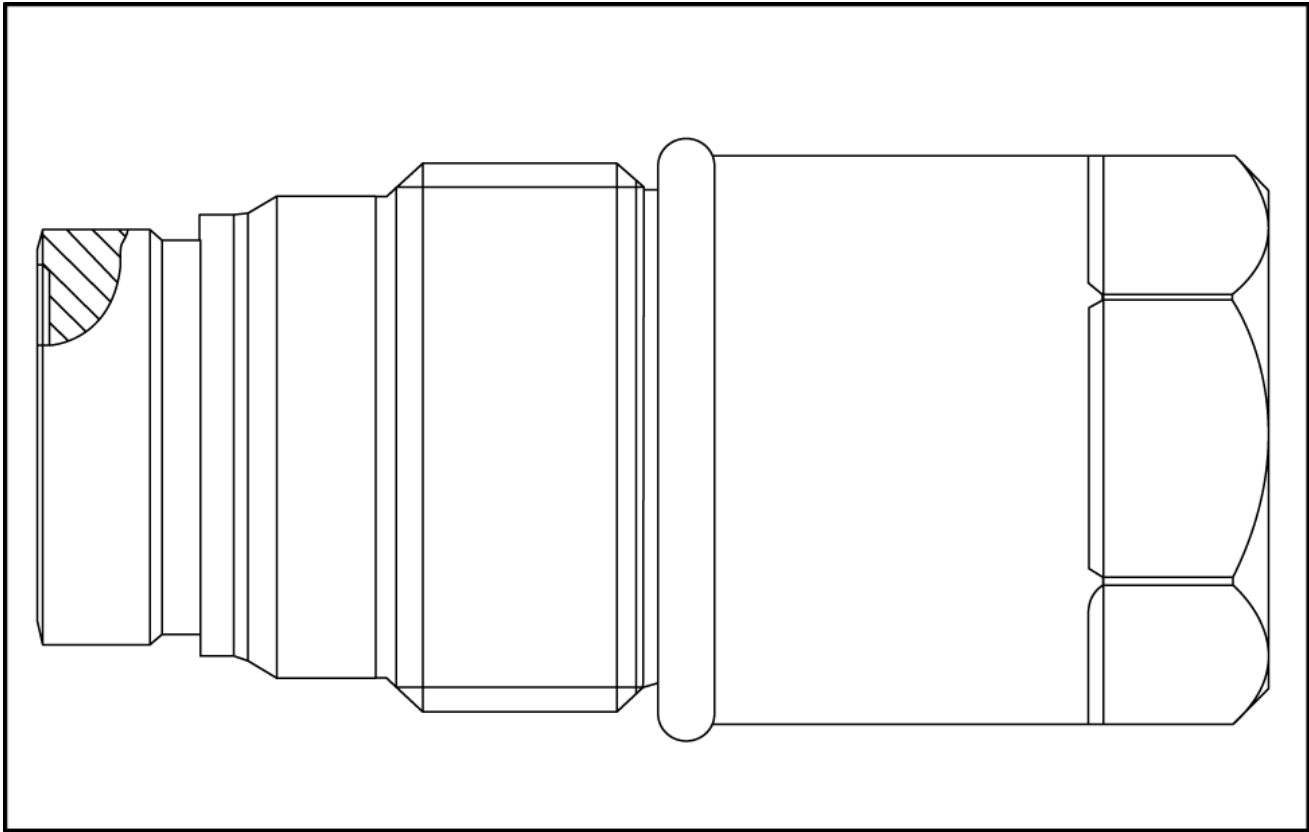

83115049 1

A mechanical device consisting of a housing, piston, spring and a shim. At a defined pressure, the limiting valve opens and the spring and piston regulate the pressure to maintain minimum engine power.

Operating characteristics	
Limiting valve opening pressure	2550 - 2750 bar (36975 - 39875 psi)
Maximum allowable rail pressure	2400 bar (34800 psi)
Maximum allowable fuel temperature in the return circuit	160 °C (320 °F)

CLICK HERE TO **DOWNLOAD** THE COMPLETE MANUAL

- Thank you very much for reading the preview of the manual.
- You can download the complete manual from: www.heydownloads.com by clicking the link below



- Please note: If there is no response to CLICKING the link, please download this PDF first and then click on it.

CLICK HERE TO **DOWNLOAD** THE COMPLETE MANUAL

Injection pump - Install

1. Determine if your engine has a full flywheel housing or a partial flywheel housing. When referencing timing marks on the flywheel throughout this procedure, it is important to note the following:
 - If your engine is equipped with a full flywheel housing, timing marks on the flywheel will be viewed through the inspection window on the bottom side of the engine.
 - If your engine is equipped with a partial flywheel housing, (open on the bottom), timing marks on the flywheel will be viewed through the mounting hole of the flywheel speed sensor.
2. Rotate the crankshaft, as viewed from the flywheel side, counter-clockwise until the hole on the edge of the flywheel with two notches or timing marks can be seen through the mounting hole as determined in Step 1.

NOTE: The two notches indicate the 54° mark.

3. Rotate the crankshaft counter-clockwise three holes from the 54° mark. This hole indicates that the engine is at 36° Before Top Dead Center (BTDC).

NOTE: Each hole represents 6° of crankshaft rotation.

4. Install tool **380000150** through the mounting hole for flywheel speed sensor until the tool is fully engaged with the hole in the flywheel.
5. Vertically position the alignment key (1) for the pump shaft.
6. Install the pump.
7. Torque the bolts (1) to **35 - 40 N·m (26 - 30 lb ft)**
8. Torque the bolts (2) to **35 - 40 N·m (26 - 30 lb ft)**.
9. Connect the low pressure fuel lines (3) and torque to **34 - 40 N·m (25 - 30 lb ft)**.
10. Connect the high pressure fuel lines (4) and torque to **60 N·m (44 lb ft)**.

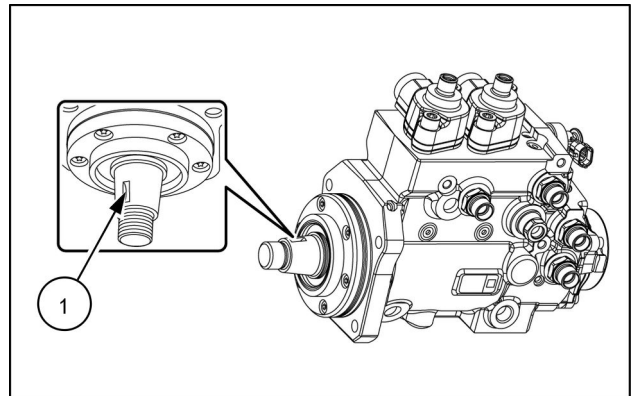

83116710 1

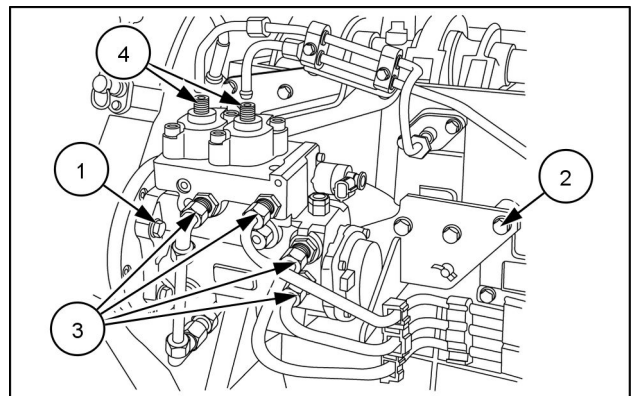

83116792 2

11. Install the gear (1) on the pump shaft.
12. Torque the nut (2) to **235 - 265 N·m (173 - 195 lb ft)**.
13. Install the blow-by cover (3)

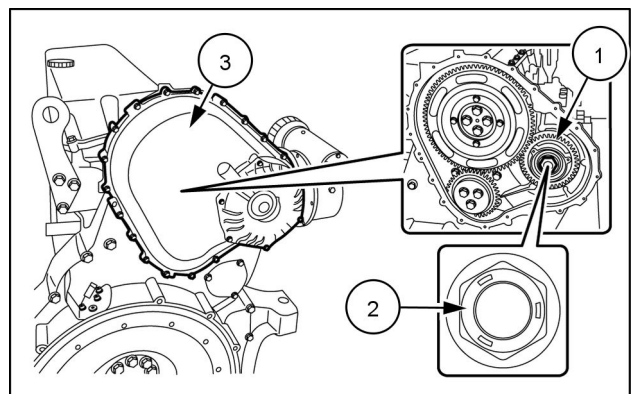

83116708 3

Turbocharger oil supply line - Remove

1. Remove the oil supply line (1) and the oil return line (2).

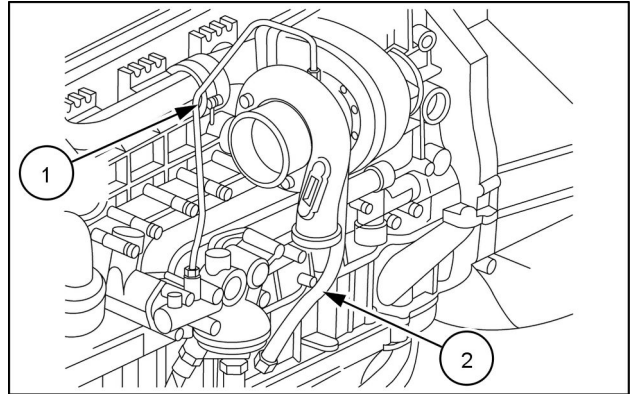

NHIL13ENG1200AA 1

Next operation:
Turbocharger oil supply line - Install (10.250)

Exhaust flap - Install

1. Position the exhaust flap and actuator onto the outlet side of the turbocharger.
2. Attach the exhaust flap to the turbocharger with a hose clamp **(1)**.
3. Tighten the hose clamp.

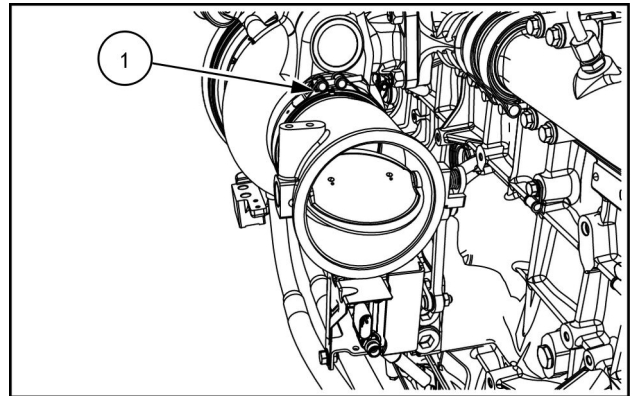

NHIL14ENG0493AA 1

4. Install the coolant lines **(1)** to the actuator.
5. Connect the electrical connector **(2)** to the actuator.

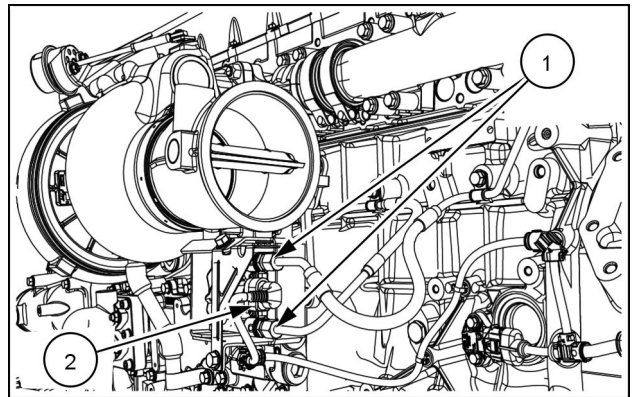

NHIL14ENG0492AA 2

Oil pressure valve - Install

Prior operation:

Oil pressure valve - Remove (10.304)

1. Mount the oil pressure adjuster valve **(1)**.

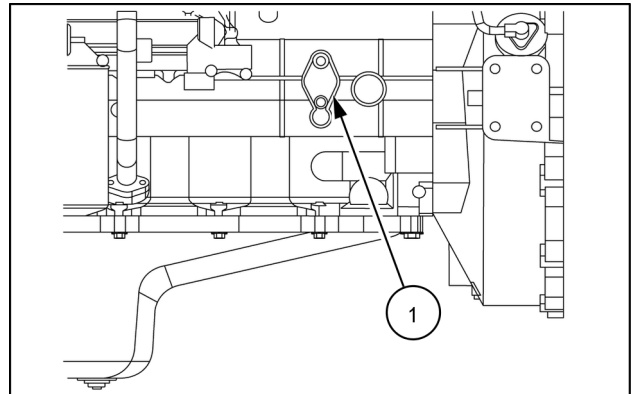

NHIL13ENG1203AA 1

Contents

Engine - 10

Engine cooling system - 400

FUNCTIONAL DATA

Engine cooling system	
Overview	3
Water pump	
Overview	4
Coolant thermostat	
Overview	5

SERVICE

Radiator to water pump hoses	
Remove	7
Install	8
Water pump	
Remove	9
Install	10
Coolant thermostat	
Remove	11
Install	12

Coolant thermostat - Install

Prior operation:

Coolant thermostat - Remove (10.400)

1. Install the thermostat and housing (1) using the appropriate tools.

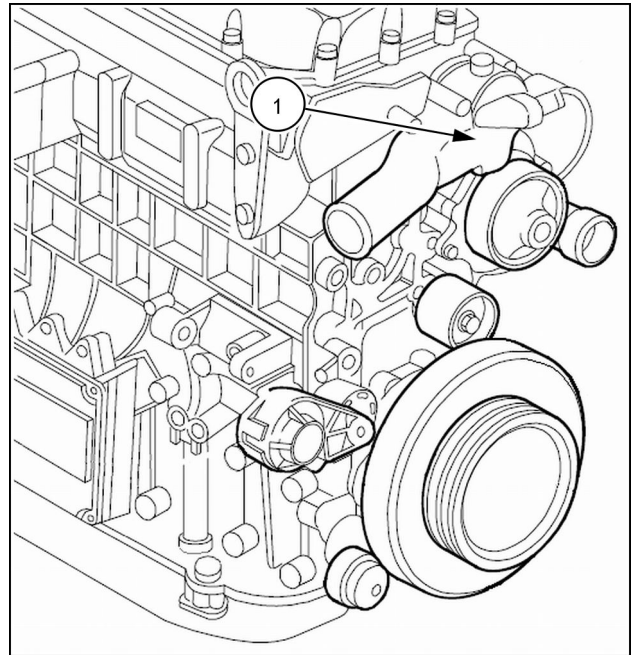

FRONTVIEW2 1

Index

Engine - 10

Fan and drive - 414

Belt - Install	4
Belt - Remove	3
Belt tensioner - Install	7
Belt tensioner - Remove	6
Idler pulley - Install	9
Idler pulley - Remove	8

Selective Catalytic Reduction (SCR) exhaust treatment - Dynamic description - Reduction of NO_x

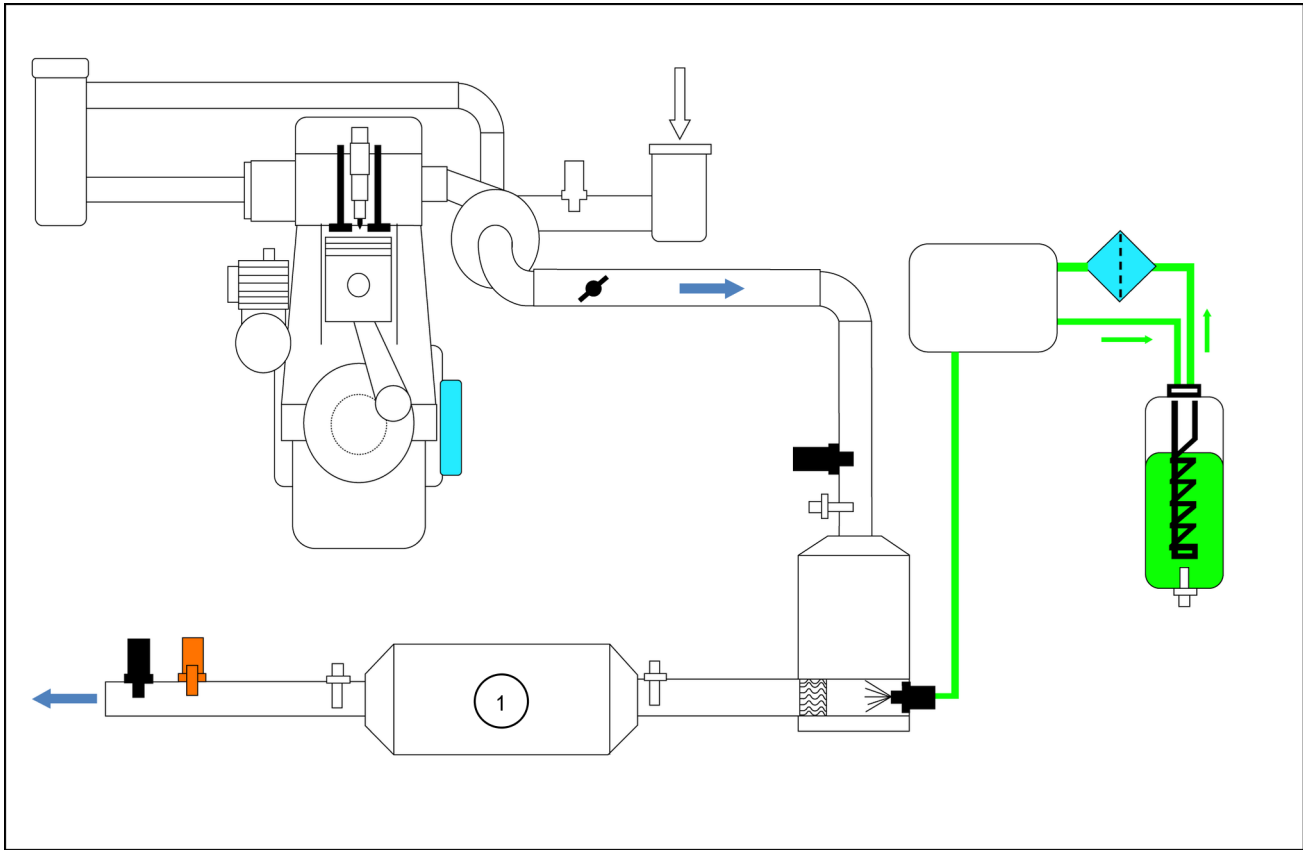

NHIL13ENG1393FA 1

The NO_x conversion depends on the amount of stored ammonia (NH₃).

When exhaust temperatures start to increase, less stored ammonia is necessary to maintain a proper NO_x efficiency level.

The amount of NH₃ which can be stored at an ammonia slip limit level of **10 ppm** increases, when temperatures start to decrease. The temperature difference is between **200.0 - 500.0 °C (392.0 - 932.0 °F)**.

NOTE: Ammonia slip refers to the amount of ammonia passing through the Selective Catalytic Reduction (SCR) (1) system un-reacted.

When the catalyst is heating up, stored NH₃ is either consumed by the SCR reactions, or it desorbs leading to an increased NH₃ slip. Desorb is the process of releasing "something" through pores.

In order to avoid NH₃ peaks, the maximum allowed storage of NH₃ has to be limited at low temperatures.

Diesel Exhaust Fluid (DEF)/AdBlue® tank - Overview

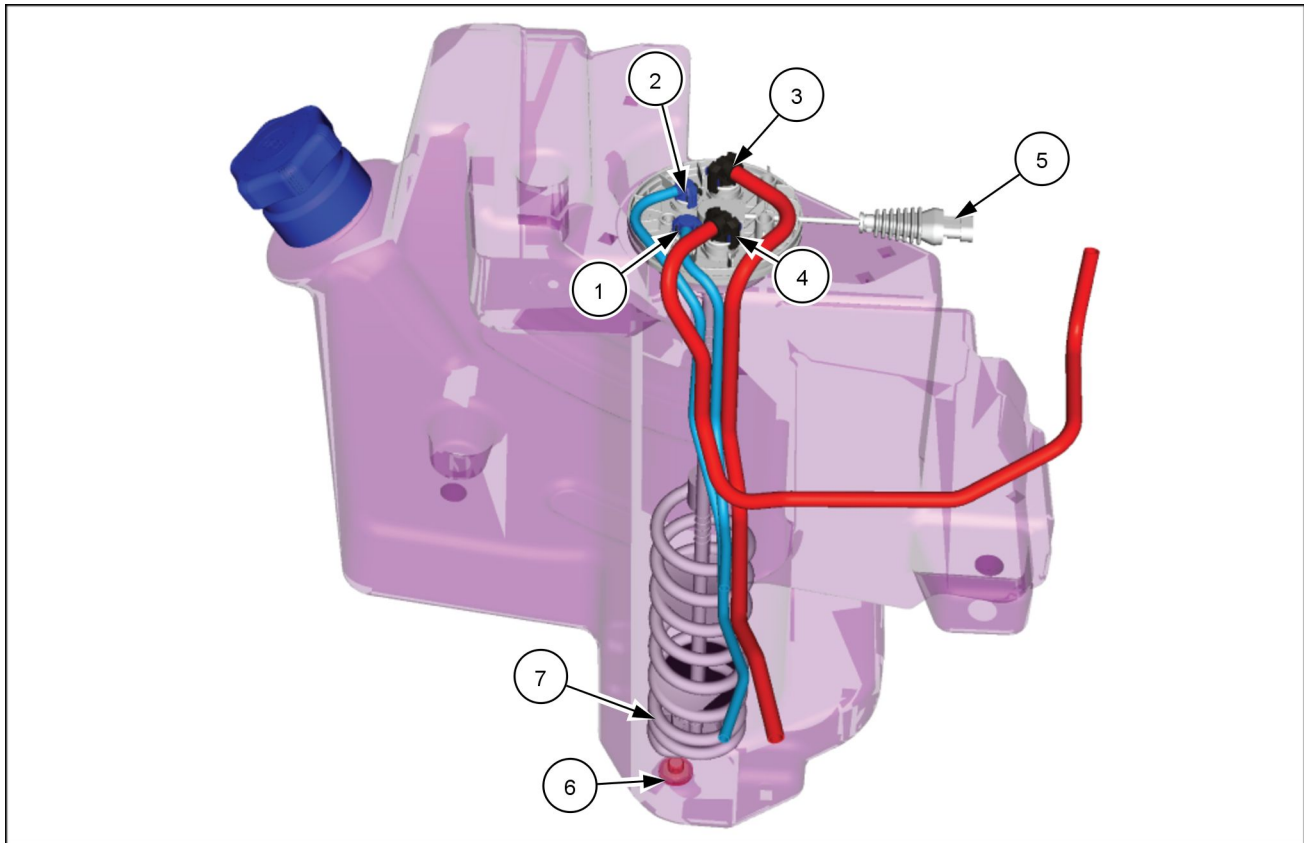

NHVM14ENG1270FA 1

- (1) Suction pipe hose assembly
- (2) Supply module return hose assembly
- (3) Coolant hose assembly supply module
- (4) Coolant control valve hose assembly
- (5) Level and temperature sensor
- (6) Quality sensor
- (7) Suction line, level and temperature sensor

Selective Catalytic Reduction (SCR) muffler and catalyst - Configure - Reset ECU data

NOTE: Active dosing faults require additional key cycles in order for the Engine Control Unit (ECU) to determine the fault has been repaired. Afterrun must be completed between each key cycle.

1. Connect the Electronic Service Tool (EST) and turn the key switch ON without starting the engine.
2. Click the “Configuration” icon (1).

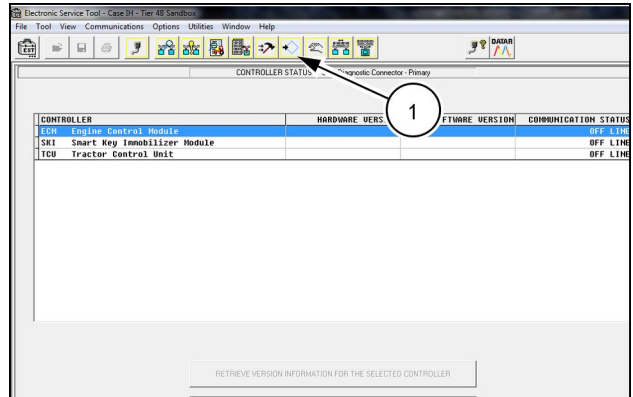

NHPH14ENG006AA 1

3. Select “Replacement of Catalyst – Reset ECU Data (1).
4. Click “CONFIGURE SELECTED ITEM” (2).

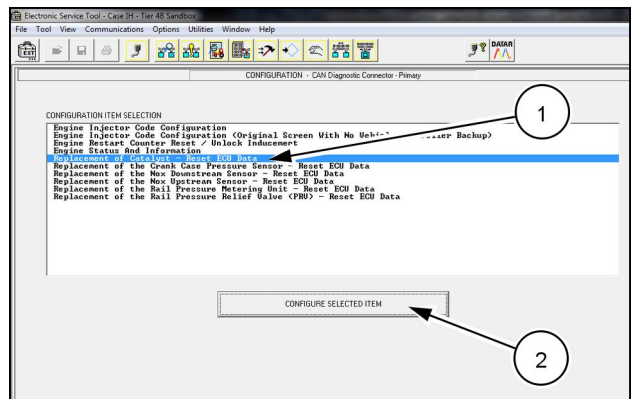

NHPH14ENG009AA 2

5. Click “RESET” (1).

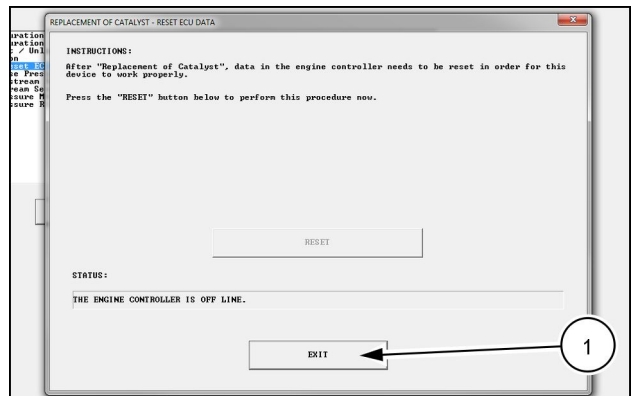

NHPH14ENG0010AA 3

Fuel pressure sensor - Overview

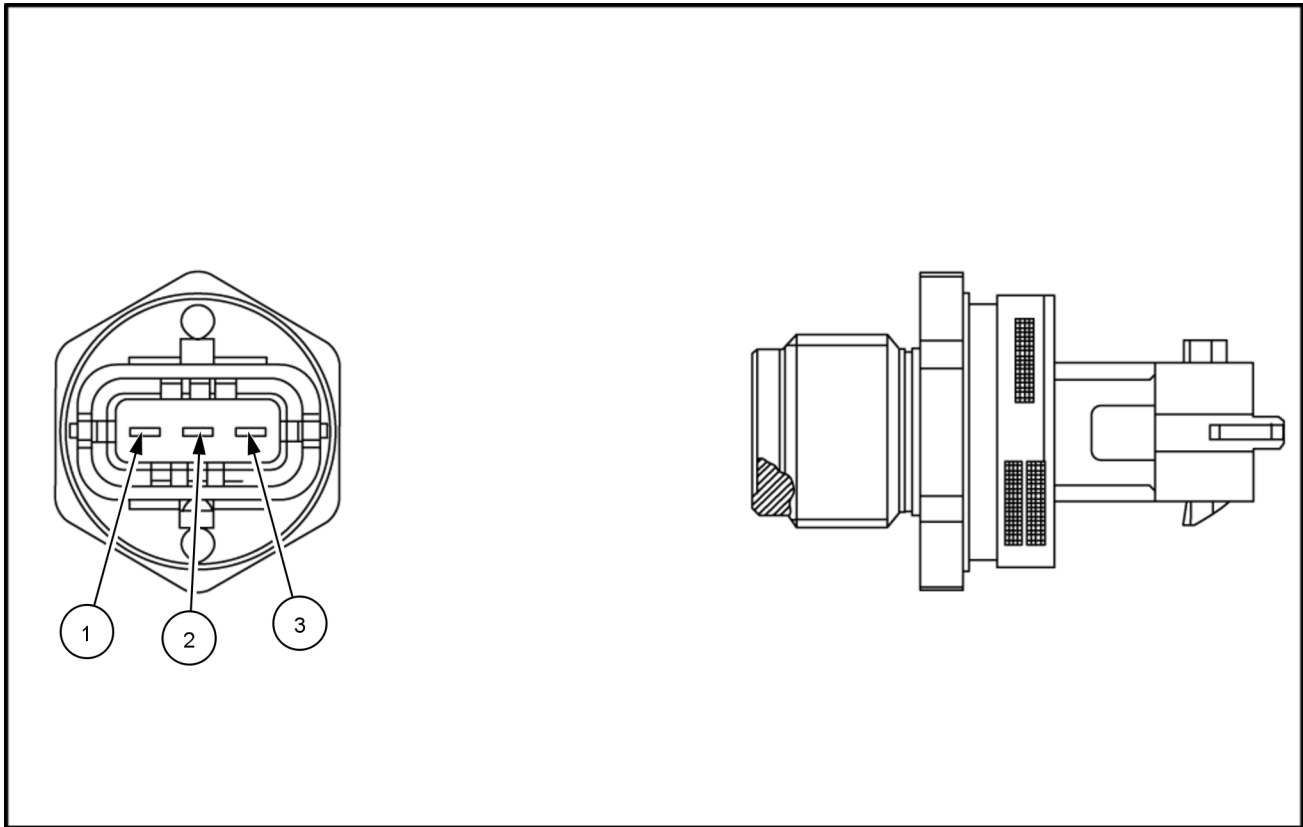

83115048 1

(1) Ground

(2) Signal

(3) Supply voltage

The high pressure sensor measures the fuel pressure in the high pressure common rail. The pressure measurement is based on the expansion of a steel diaphragm.

The pressure sensor generates an analogue output signal which is proportional to the supply voltage.

Operating characteristics	
Pressure range	0 - 2400 bar (0 - 34800 psi)
Supply voltage	5 V

Index

Electrical systems - 55

Engine oil system - 013

Engine oil pressure and temperature sensor - Overview	3
---	---

De-rating

In the event of engine overheating, the control module will decrease the power of the engine proportionally to the temperature reached by the coolant.

Injection lead electronic control

Injection lead, or the start of fuel delivery expressed in degrees, can differ from one injection to the next, even from one cylinder to another. It is calculated similarly to delivery according to engine load, accelerator position, engine RPM and air admitted.

Lead is corrected as required:

- During acceleration
- According to water temperature

and to obtain:

- Reduced emissions, noise abatement, and no overload
- Better vehicle acceleration

High injection lead is set at start, based on water temperature.

Delivery start feedback is given by the variance in impedance by the electro valve.

Engine start

The accelerator pedal position signal is ignored at start. Start delivery is set exclusively based on water temperature, via a specific map. The control module enables the accelerator pedal, when it detects flywheel acceleration and RPM above what the starter can turn.

Cold start

Pre-post heating is activated when even only one of the three water, air or engine oil temperature sensors record a temperature below **10 °C (50 °F)**. The preheat warning light goes on when the ignition key is turned on. The light stays on for a variable period of time according to temperature, while the intake air heater raises the intake temperature, then the light starts blinking, at which point the engine can be started.

The warning light switches off with the engine running, while heater continues being fed for a variable period of time to complete post-heating. The operation is cancelled to avoid useless discharging of the batteries if the engine is not started within 20 - 25 seconds with the warning light blinking. The preheat curve is also variable based on battery voltage.

Hot start

When the key is turned on, the warning light will go on for about 2 seconds for a short test then turn off when all the temperature sensors read values above **10 °C (50 °F)**. The engine can be started at this point.

Run Up

When the ignition key is turned on, the control unit transfers data stored from the engine stop to the main memory and diagnoses the system.

After Run

At each engine stop, with the ignition key off, the control unit still remains fed by the main relay for a few seconds to enable the microprocessor to transfer data from the main volatile memory to a nonvolatile, cancelable and re-writable (eprom) memory to make the information available for the next start.

This data essentially consists of:

- Miscellaneous settings, such as engine idling, etc.
- Settings of some components

Engine starter - Remove

1. Remove the starter (1) motor by removing the screws securing it to the flywheel housing.

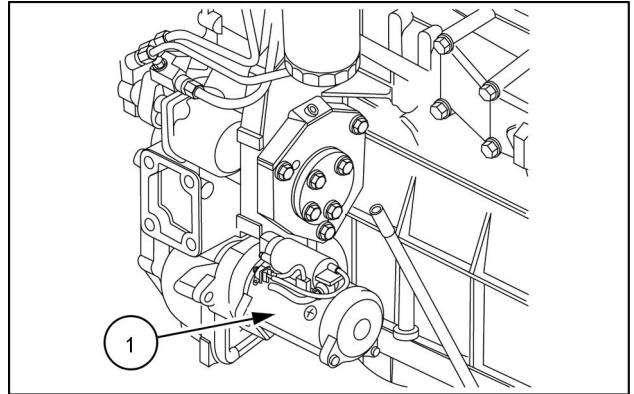

NHIL13ENG1228AA 1

Next operation:
Engine starter - Install (55.201)

Alternator - Remove

Prior operation:

Belt - Remove (10.414)

1. Remove the alternator (3) and it's supports (1) and (2).

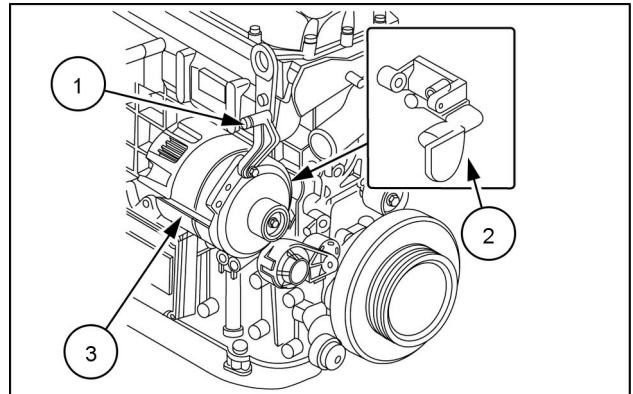

NHIL13ENG1128AA 1

Next operation:

Alternator - Install (55.301)

Diesel Exhaust Fluid (DEF)/AdBlue® tank level and temperature sensor - General specification

Working temperatures	-40 - 85 °C (-40 - 185 °F)
----------------------	----------------------------

Maximum ratings	
Voltage	48 V
Current	300 mA
Power	1.25 W
Negative Temperature Coefficient (NTC)	500 Ω

Temperature	Resistance
-40 °C (-40 °F)	23342 Ω
-30 °C (-22 °F)	13018 Ω
-20 °C (-4 °F)	7569 Ω
-10 °C (14 °F)	4569 Ω
0 °C (32 °F)	2854 Ω
10 °C (50 °F)	1838 Ω
20 °C (68 °F)	1217 Ω
25 °C (77 °F)	1000 Ω
30 °C (86 °F)	826.70 Ω
40 °C (104 °F)	574.60 Ω
50 °C (122 °F)	407.40 Ω
60 °C (140 °F)	293.70 Ω
70 °C (158 °F)	214.90 Ω
80 °C (176 °F)	159.30 Ω
90 °C (194 °F)	119.40 Ω
100 °C (212 °F)	90.46 Ω
110 °C (230 °F)	69.16 Ω
120 °C (248 °F)	53.32 Ω
130 °C (266 °F)	41.44 Ω
140 °C (284 °F)	32.43 Ω
150 °C (302 °F)	25.56 Ω

NOTE: The level sensor specifications vary depending on the size of the DEF/AdBlue® tank.

Nitrogen Oxides (NO_x) sensor - Dynamic description

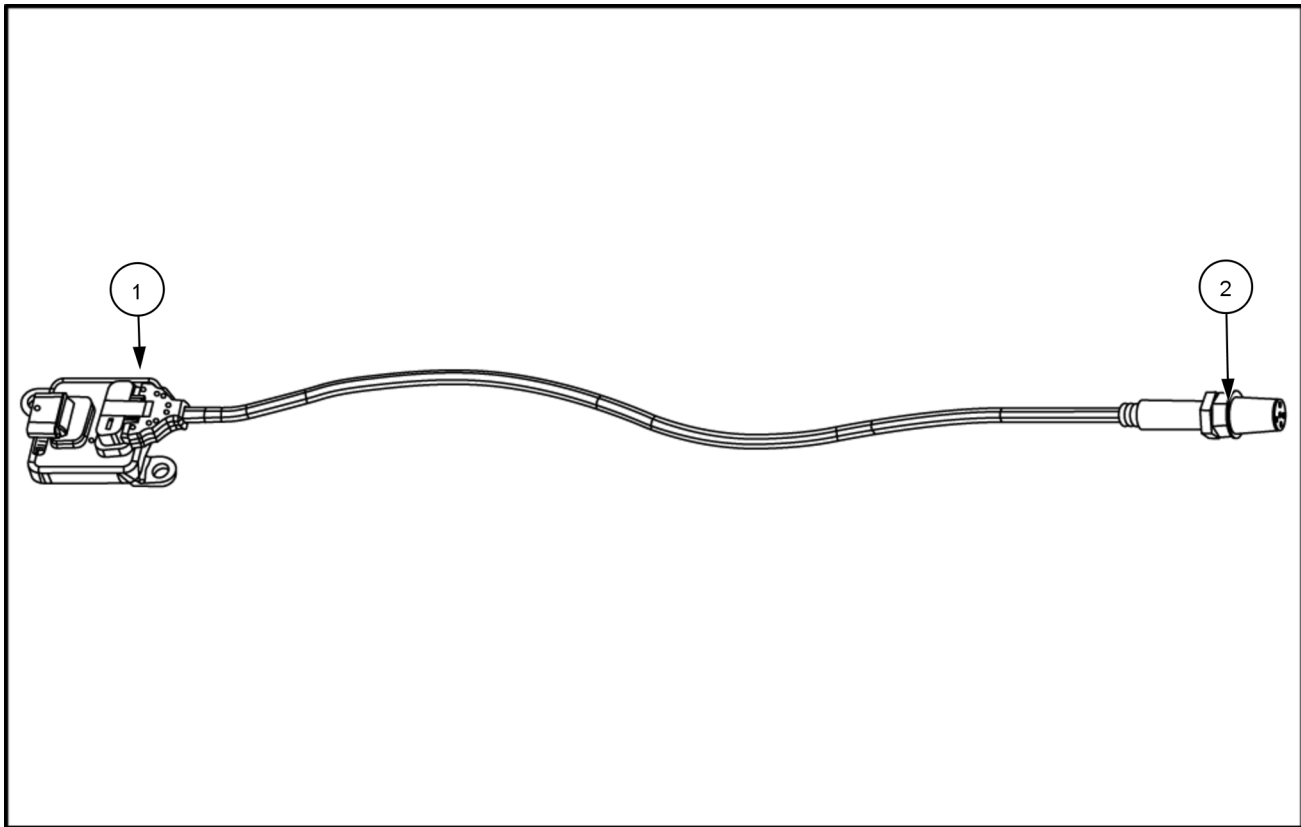

NHIL13ENG1382AA 1

The NO_x sensor consists of two components, the sensor **(2)** in the exhaust stream, and also the controller **(1)** which reports the data to the Engine Control Unit (ECU) via the engine Controller Area Network (CAN) data bus.

Once the Selective Catalytic Reduction (SCR) chamber is up to operating temperature **240.0 °C (464.0 °F)**, Diesel Exhaust Fluid (DEF)/AdBlue® can be injected into the system per engine calculations (open loop).

After approximately **6 - 15 min** (if catalyst and engine temperature is reached and maintained), the NO_x sensors will come online, and DEF/AdBlue® will be injected based on the sensors readings (closed loop).

The time delay (Dew point) is needed to ensure no moisture is on the sensing tips of the sensors which could damage them upon initial startup.

- The Upstream NO_x sensor will appear online before the Downstream due to its position.
- The NH₃ sensor will appear online immediately after the Downstream NO_x sensor appears.
- If viewing the “Dew Point” parameter of the sensors, it will read “not ready” until the moisture is wicked off the tip of the sensor. Then it will read “Ready”.
- When turning the key switch ON then OFF then ON, the dew point (warm up cycle) begins again. The NO_x sensors may return to a “Ready” status quicker than previously depending upon engine shut down time, engine coolant, and catalyst temperature.

Upstream NO_x sensor

The upstream NO_x sensor is located before the Diesel Oxidation Catalyst (DOC). This measures the level of pollutants coming directly from the engine. It also senses any raw, unburned fuel coming from the combustion chambers.

Downstream NO_x sensor

The downstream NO_x sensor is located directly after the Selective Catalytic Reduction (SCR). This sensor measures the pollutants making it through the Diesel Oxidation Catalyst (DOC) and SCR and out of the tailpipe. The data from this sensor is compared to that of the upstream sensor. If the data between the two sensors becomes more similar, the vehicle's computer may trigger a catalyst inefficiency code, which turns on a warning light.

CLICK HERE TO **DOWNLOAD** THE COMPLETE MANUAL

- Thank you very much for reading the preview of the manual.
- You can download the complete manual from: www.heydownloads.com by clicking the link below



- Please note: If there is no response to CLICKING the link, please download this PDF first and then click on it.

CLICK HERE TO **DOWNLOAD** THE COMPLETE MANUAL