

**686G, 686GXR and 688G SERIES 2
TELESCOPIC HANDLERS
Service Manual
7-16041**

Table of Contents

Description	Section No.	Form No.
General		
	Tab 1	
Section Index - General		7-16070
Standard Torque Specification	1001	8-71601
Fluids and Lubricants	1002	7-16080
Safety and General Information	1003	7-16090
Loctite Product Chart		8-98902
Engine		
	Tab 2	
Section Index- Engine		7-90140
Diesel Engine Specifications	2000	7-16100
Engine and Transmission Removal and Installation	2001	7-89691
Engine Troubleshooting	2002	7-89701
Fuel System		
	Tab 3	
Section Index- Fuel System		7-16110
Electrical		
	Tab 4	
Section Index - Electrical		7-16700
Electrical System General	4000	7-16710
Electrical Schematics and Troubleshooting	4001	7-16720
Electrical Gauges and Senders	4005	7-89741
Alternator	4007	7-49250
Steering		
	Tab 5	
Section Index - Steering		7-90170
How It Works	5000	7-89751
Steering Specifications	5001	7-89760
Steering Troubleshooting	5002	7-89771
Steering Pump and Steering Column	5003	7-89781
Steering Selector Valve	5004	7-89791
Steering Priority Valve	5005	7-89800

Reprinted

CLICK HERE TO **DOWNLOAD** THE COMPLETE MANUAL

- Thank you very much for reading the preview of the manual.
- You can download the complete manual from: www.heydownloads.com by clicking the link below



- Please note: If there is no response to CLICKING the link, please download this PDF first and then click on it.

CLICK HERE TO **DOWNLOAD** THE COMPLETE MANUAL

Section 1002

1002

FLUIDS AND LUBRICANTS

CASE CORPORATION
700 State Street
Racine, WI 53404 U.S.A.

CASE CANADA CORPORATION
450 Sherman Avenue
Hamilton, ON L8N 4C4 CANADA

Bur 7-16080

© 1999 Case Corporation
Printed in U.S.A.
November, 1999

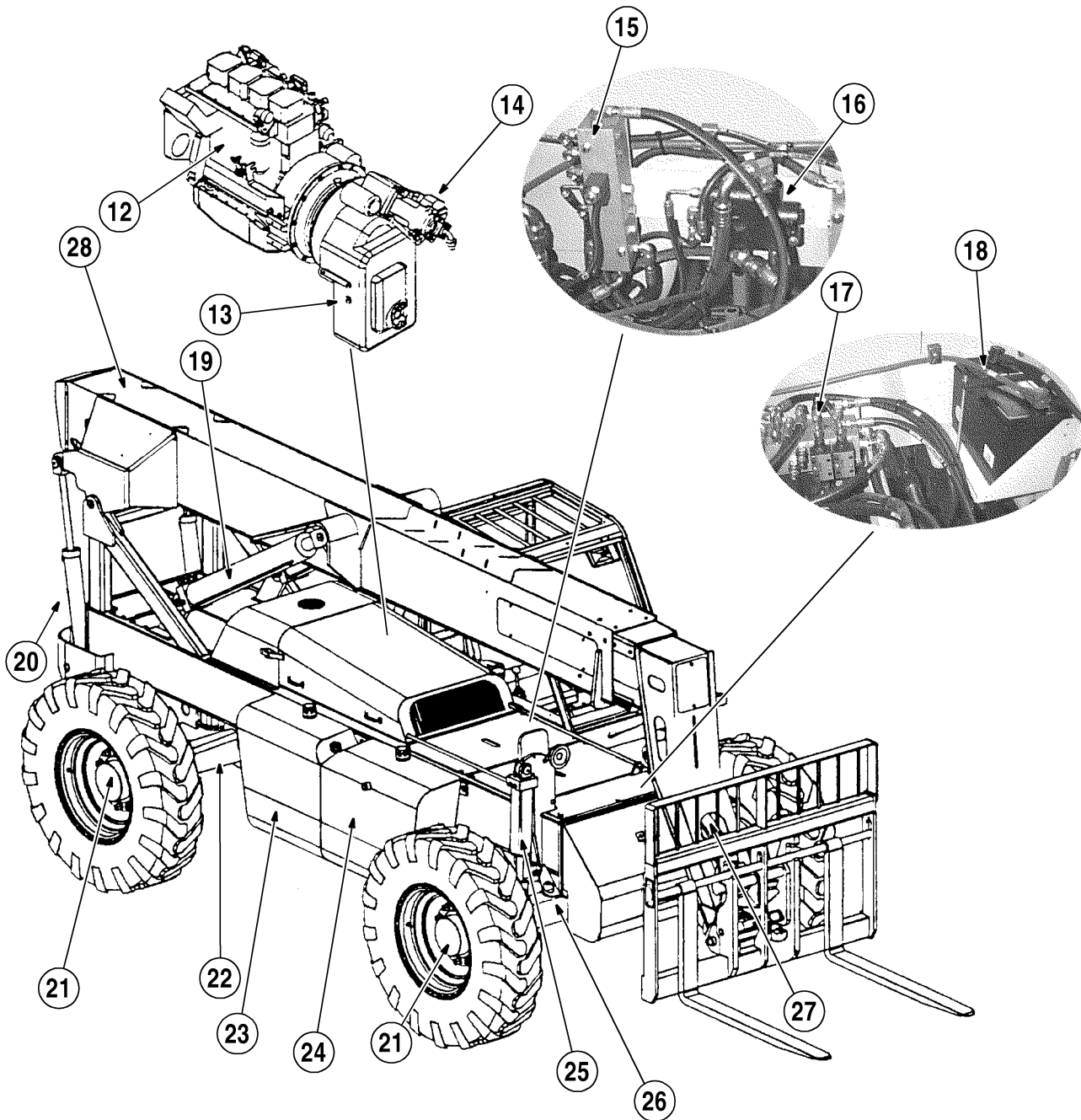

BS99A105

- | | |
|-------------------------------------|---|
| 12. ENGINE | 21. PLANETARY WHEEL END (BOTH SIDES) |
| 13. TRANSMISSION | 22. REAR AXLE |
| 14. HYDRAULIC PUMP | 23. FUEL TANK |
| 15. HYDRAULIC DRAIN MANIFOLD | 24. HYDRAULIC TANK |
| 16. PRIORITY VALVE | 25. FRAME LEVEL CYLINDER |
| 17. FRAME LEVEL/FORK TILT MANIFOLD | 26. FRONT AXLE |
| 18. BATTERY | 27. CARRIAGE TILT CYLINDER |
| 19. BOOM LIFT CYLINDER (BOTH SIDES) | 28. CROWD CYLINDER - LOCATED INSIDE BOOM ASSEMBLY |
| 20. TILT COMPENSATION CYLINDER | |

Major Components (Illustration 2 of 2)

Section

2001

ENGINE AND TRANSMISSION REMOVAL AND INSTALLATION

CASE CANADA CORPORATION
450 Sherman Avenue
Hamilton, ON L8N 4C4 CANADA

CASE CORPORATION
700 State Street
Racine, WI 53404 U.S.A.

Bur 7-89691

© 1999 Case Corporation
Printed in U.S.A.
November, 1999

TROUBLESHOOTING, ENGINE

<u>PROBLEM</u>	<u>POSSIBLE CAUSE</u>
Engine will not start and the starter does not rotate	Fuse is defective Batteries discharged Battery cable connections loose or disconnected In-line line fuse to starter fused Faulty starter relay Ignition switch defective Starter solenoid or starter defective
Engine will not start and the starter does rotate	Empty fuel tank Air in fuel system Clogged fuel filter Fuel solenoid at fuel pump defective Intake air system restricted Contaminated fuel
Engine difficult to start and has poor and irregular performance	Low battery power Batteries discharged Battery cable connections are loose or corroded causing the starter to turn too slowly Oil viscosity too high for cold (winter) conditions Fuel line blockage due to wax separation in winter Incorrect valve clearance Defective fuel injectors Defective turbocharger Air cleaner element restricted Loose or badly adjusted throttle cable
Engine making excessive fumes	Lugging engine Air in fuel system Engine oil level too high Air cleaner/filter plugged Low compression due to poor condition of the valves or incorrect valve clearance Injection pump timing incorrect Air leak between turbocharger and intake/exhaust manifold Multiple seal washers under injector nozzle Injector nozzle malfunction Faulty turbocharger Engine running too cold Injection pump overfueled

Continued on next page

ELECTRICAL SYSTEM SPECIFICATIONS

System Voltage 12 volts, Negative ground
Alternator 12 volt 65 amp, 62 amperes at 2800 rpm (hot)
Battery (Quantity).....1 group 31 (“maintenance-free”)
Cold Cranking Amperes..... 1000 amperes

GAUGES AND SENDERS

Gauges and senders cannot be repaired. Gauges and senders are replaced when they are defective. The most common cause of failure is a bad connection or defective wiring. There are no adjustments. This section describes replacement procedures. Before a gauge or sender is replaced, make the following checks:

1. Make sure that the other gauges and electrical circuits are operating correctly.
2. Make sure the battery is charged, correctly installed and the cable terminals are clean and tight.
3. Make sure the wires and connections to the unit are tight and in good condition.

Gauge Replacement

Gauges are mounted on the gauge mounting plate on the instrument panel mounting frame in the cab. Access to the back of the gauge mounting plate is required for gauge replacement.

1. Make sure KEY switch is in the OFF position.
2. Disconnect the battery ground cable from battery.
3. Remove locknuts, screws, and gauge assembly from the instrument panel mounting frame.
4. Identify and tag gauge wires to be removed, so that they can be connected again correctly.
5. Disconnect wires from gauge to be removed.
6. Remove nuts, lockwashers, mounting bracket, and gauge from the gauge mounting plate.
7. Install replacement meter in the gauge mounting panel. Make sure the gauge is in the correct orientation for the operator.
8. Install mounting bracket, lockwashers, and nuts. Secure gauge to gauge mounting plate.

CAUTION: Make sure that gauge wire connectors do not touch wire connectors for other gauges, mounting bracket, or bracket mounting nut. Install gauge wire connectors so that the wires are not in tension.

9. Connect wires to the gauge terminals.
10. Install gauge assembly, screws and locknuts to the instrument panel mounting frame.
11. Connect the battery ground cable to the battery.

Fuel Level Sender

The fuel level sender is fastened to the surface of the fuel tank with screws through the sender plate and gasket.



WARNING: Fuel vapors are explosive. DO NOT SMOKE. Make sure there is no open flame or sparks in the vicinity. Do not make sparks by using tools.

M657

1. Make sure the key switch is in the OFF position.
2. Disconnect the battery ground cable from the battery.
3. Disconnect the sender wire.
4. Remove the screws that fasten the sender plate to the tank.
5. Remove the sender.

NOTE: The float and float arm must have clearance so that they can move without interference from the side of the fuel tank.

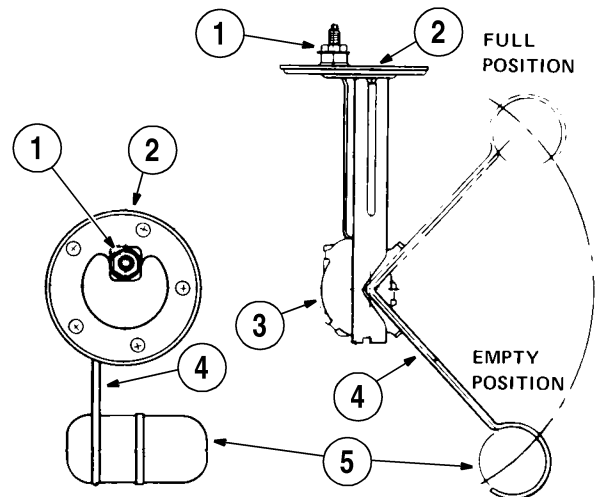

BS98M156

- | | |
|--------------------------|--------------|
| 1. ELECTRICAL CONNECTION | 4. FLOAT ARM |
| 2. PLATE | 5. FLOAT |
| 3. SENDER UNIT | |

Replacement Fuel Sender

INSPECTION AND TESTING OF ROTOR

STEP 26

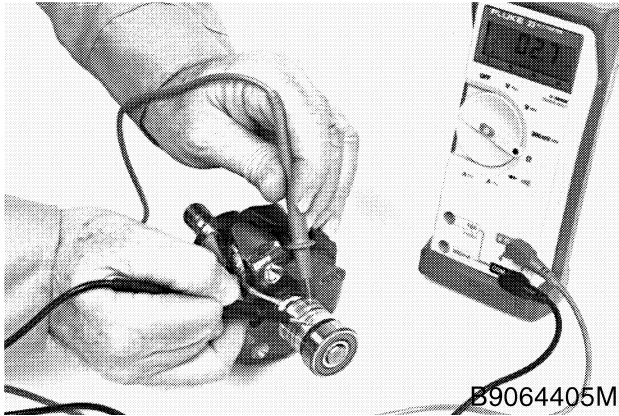

B9064405M

Touch the leads of the ohmmeter to the slip rings. The reading must be 2.52 to 3.08 ohms. If the reading is not as specified, a new rotor must be installed.

STEP 27

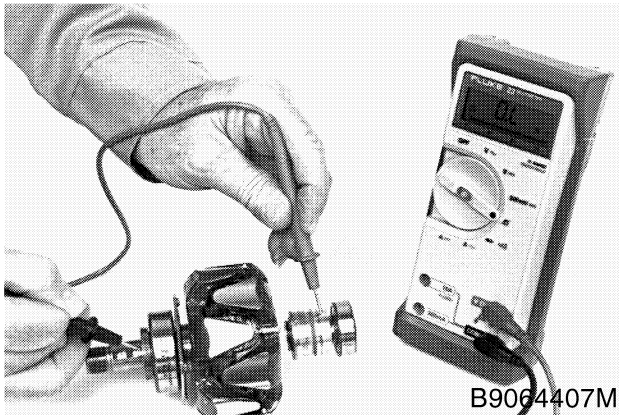

B9064407M

Touch the leads to each slip ring and the shaft. If a reading shows continuity, a new rotor must be installed.

STEP 28

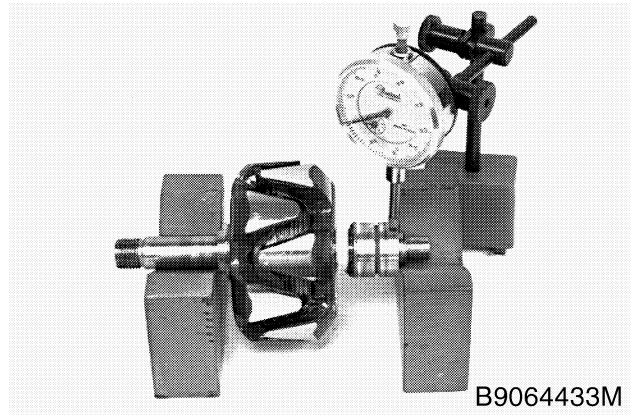

B9064433M

Use a dial indicator and measure the runout of each slip ring. If the runout is more than 0.002 inch (0.05 mm) a new rotor must be used or use a lathe to remove enough material until the runout is less than specified.

STEP 29

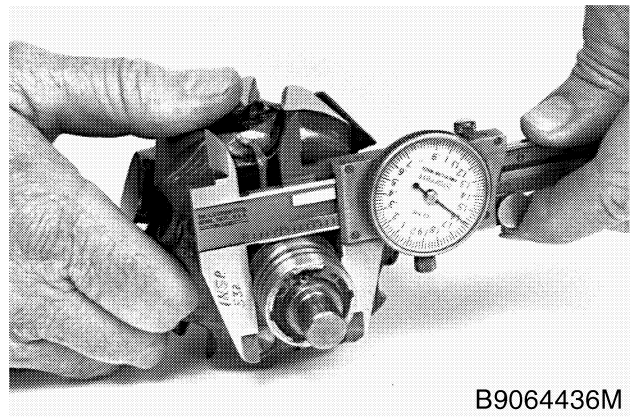

B9064436M

Measure the diameter of the slip ring. The diameter must not be less than 1.055 inch (26.8 mm).

STEP 53

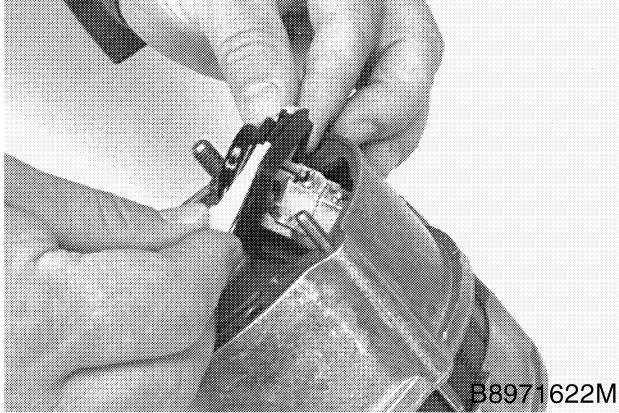

Install the voltage regulator and the brush holder. Be careful not to damage the brushes.

STEP 54

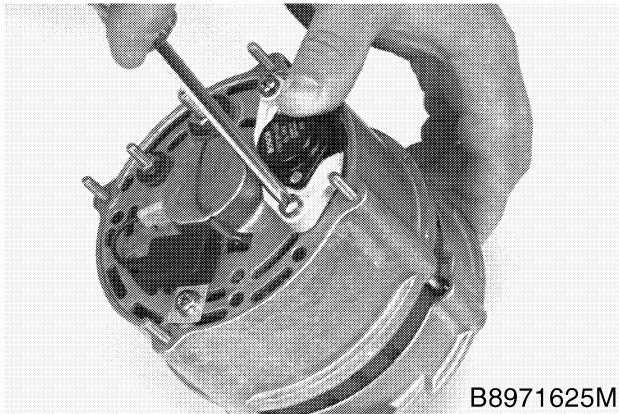

Install the screws and flat washers and tighten the screws.

STEP 55

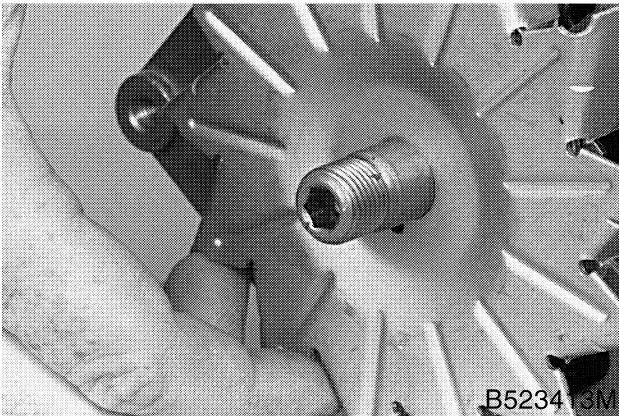

Install the fan.

STEP 56

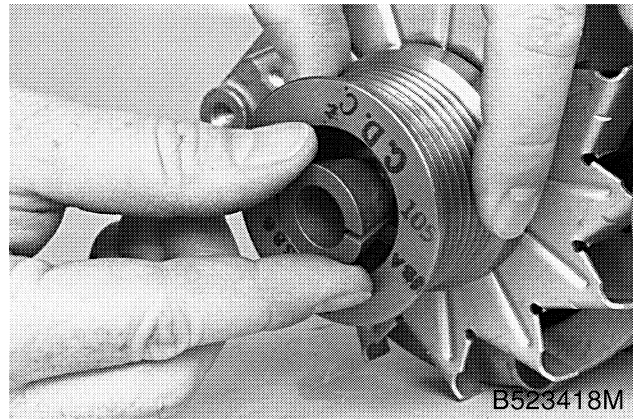

Install the pulley and the tapered bushing.

STEP 57

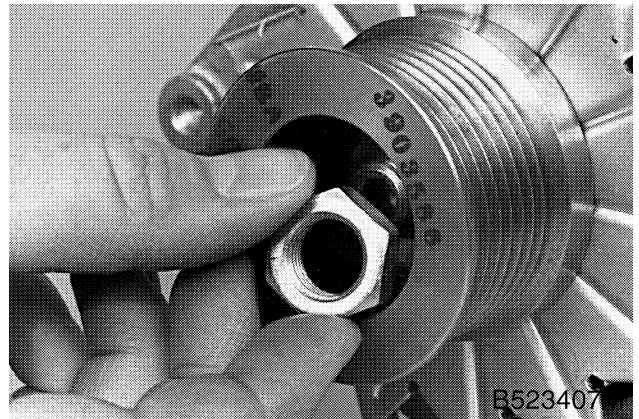

Install the lock washer and start the nut onto the shaft.

STEERING SYSTEM SPECIFICATIONS

STEERING CONTROL VALVE

Type	Hydrostatic, Open-center, Non-Load-reaction
Lubrication	Hydraulic Oil
Displacement	231.2 cm ³ (14.1 in ³) per revolution
Steering Relief Pressure	14986 kPa, 150 bar (2175 psi)
Control Spring Pressure	1598 kPa, 16 bar (232 psi)
Turns, Stop-to-Stop (in 4 wheel steering)	3.5 turns

TURNING RADIUS

Inside (686G)	180 cm (71.0 in)
Outside (686G)	414 cm (163 in)
Inside (686G XR)	196.8 cm (77.5 in)
Outside (686G XR)	429 cm (169 in)

HYDRAULIC STEERING PUMP

*Uses the main pump system

STEERING CYLINDER

Type	Double-acting
------------	---------------

WHEEL ANGLE (FULL TURN)

Inside Wheel	40°
Outside Wheel	28°
Toe-in, each wheel	0°xx

TIRES

Size	13.00 x 24 12 ply
Location	All
Tire Pressure Specification	448 kPa, 4.5 (65 psi)
Lug Nut Specification	619 Nm (442 pound-feet)

Section 5004

STEERING SELECTOR VALVE

5004

CASE CORPORATION
700 State Street
Racine, WI 53404 U.S.A.

CASE CANADA CORPORATION
3350 SOUTH SERVICE ROAD
BURLINGTON, ON L7N 3M6 CANADA

Bur 7-89790

© 1999 Case Corporation
Printed in U.S.A.
November, 1999

SECTION INDEX - POWER TRAIN

Section Title

Section Number

How It Works	6000
Removal and Installation of Power Train Components	6001
Transmission Specifications and Troubleshooting	6002
Drive Axle.....	6004

CASE CORPORATION
700 State Street
Racine, WI 53404 U.S.A.

CASE CANADA CORPORATION
3350 SOUTH SERVICE ROAD
BURLINGTON, ON L7N 3M6 CANADA

Bur 7-90180

© 1999 Case Corporation
Printed in U.S.A.
November, 1999



WARNING: Use acceptable lift/support equipment that is capable of handling the weight of the transmission.

M693

Transmission Installation

1. Attach transmission to acceptable lift/support equipment.
2. Move the transmission into position so that it can be attached to the engine.
3. Align the transmission with the two 100 mm (4 inch) long studs that were installed in the engine flywheel housing during the removal procedure. Slide the transmission onto the studs.
4. Insert a rod or screw driver 152 mm to 203 mm (6.0 inch to 8.0 inch) long through flywheel access hole and align with transmission drive plate holes. (See page 6001-3.)

NOTE: For steps 4-7 see *Transmission/Engine Assembly diagram on page 6001-4.*

5. Apply Loctite 242 to eight bolts (2) and install through the flywheel access hole on the engine to secure transmission drive plate to engine flywheel. Rotate engine by hand until holes are aligned to allow installation of bolts. Tighten to 122 Nm (90 ft-lb).
6. Place a washer (7) onto each bolt (8). Apply Loctite 242 to each bolt and install them through the transmission mounting flange and into the engine. Tighten the bolts to 61 Nm (45 ft-lb).

7. Remove the two 100 mm (4.0 inch) long studs. Apply Loctite 242 to the remaining two bolts (8) with washers (7). Install the bolts and tighten to 61 Nm (45 ft-lb).
8. Place a washer (5) on each bolt (4) and apply Loctite 271 to the bolts. Install the bolts through transmission mounting brackets (6) on each side of the transmission. Tighten the bolts to 150 Nm (111 ft-lb).
9. Install access cover. (See page 6001-3)
10. Reconnect front and rear drive shafts to the transmission.
11. Remove the lifting equipment and supports from the transmission and engine.
12. Connect the hydraulic hoses to hydraulic pump using tags installed.
13. Connect any electrical wiring that was disconnected during the removal procedure.
14. Fill the transmission with fresh transmission oil. Refer to the Operators manual for required type and quantity.
15. Start the engine and check for leaks and test the operation of the transmission. Repair as necessary.
16. Install deck plates and hood assembly.
17. Remove boom stop and stow it on the floor behind the operator's seat.

Refer to the Transmission Maintenance and Service manual which has been provided with your 686G, 686G XR, and 688G Series 2 Service Manual Kit for disassembly and assembly procedures.

AXLE SPECIFICATIONS

Axle Mounting Bolt torque756 Nm (540 pound-feet)

RATIOS

Gear Reduction, Total19:09:1

Pinion and Ring Gear3:18:1

Planetary Gears6:0:1

OIL

Type:SAE 80W/90W EP

REAR AXLE

Center Bowl (differential carrier)6.6 liters (7 U.S. quarts)

Planetary wheel ends0.9 liters (1 U.S. quart)

FRONT AXLE

Center Bowl (differential carrier)6.6 liters (7 U.S. quarts)

Planetary wheel ends0.9 liters (1 U.S. quart)

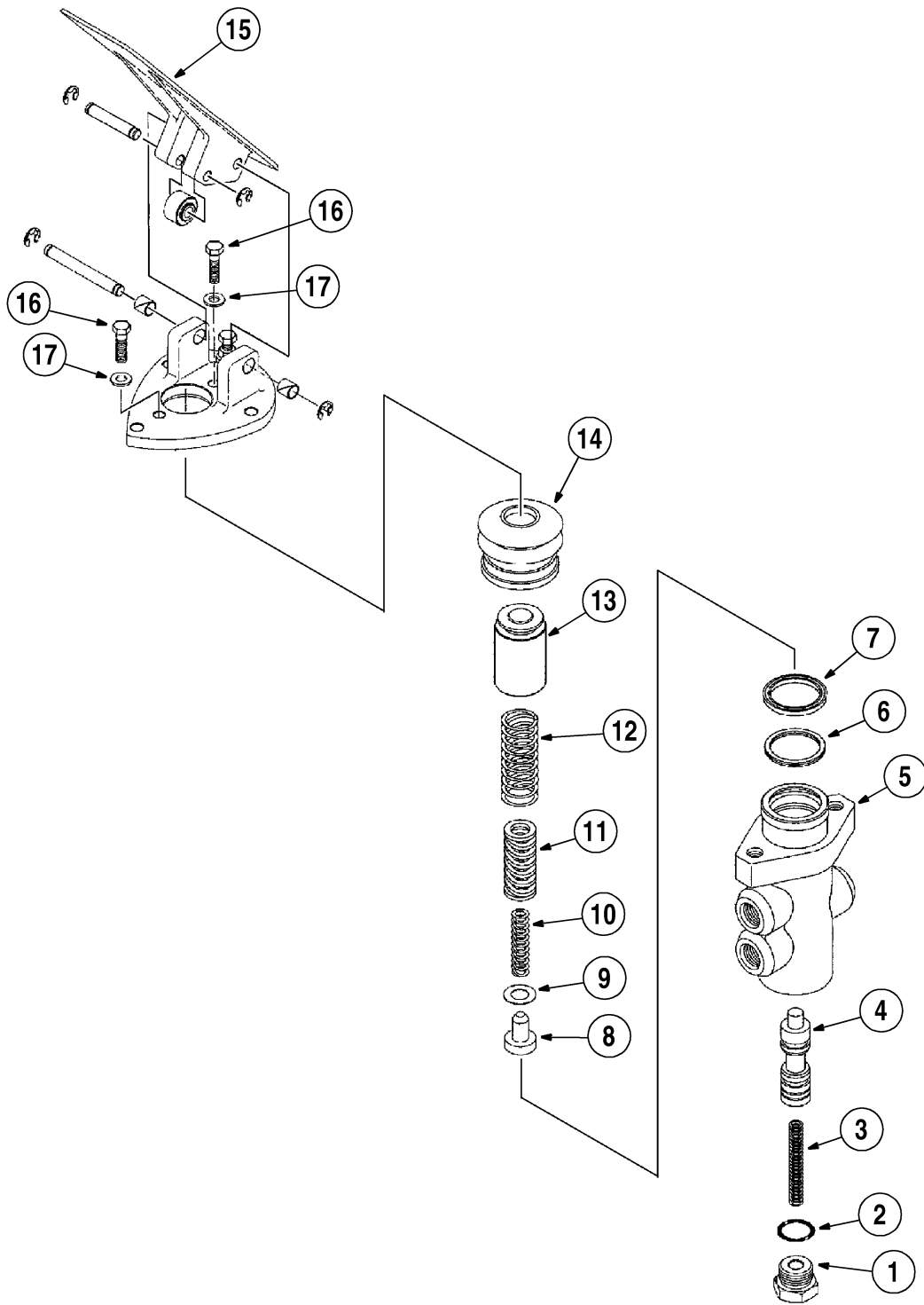

- 1. END PLUG
- 2. O-RING
- 3. SPRING
- 4. SPOOL
- 5. HOUSING
- 6. SEAL

- 7. CUP
- 8. RETAINER ASSEMBLY
- 9. SHIM
- 10. SPRING
- 11. SPRING
- 12. SPRING

- 13. PISTON
- 14. BOOT
- 15. BRAKE PEDAL
- 16. CAP SCREW
- 17. WASHER

BS98N082

Brake Pedal and Brake Valve

Section

7003

7003

BRAKE SYSTEM

REMOVAL AND INSTALLATION OF

COMPONENTS

CASE CORPORATION
700 State Street
Racine, WI 53404 U.S.A.

CASE CANADA CORPORATION
450 Sherman Avenue
Hamilton, ON L8N 4C4 CANADA

Bur 7-89891

© 1999 Case Corporation
Printed in U.S.A.
November, 1999

HYDRAULIC SYSTEM- HOW IT WORKS

Operation

The hydraulic system has one hydraulic pump and reservoir. As the engine turns the hydraulic pump, the vacuum at the pump inlet draws the hydraulic fluid into the pump. Piston action of the pump forces hydraulic fluid out of the pump under pressure to the manifold of the priority valve. Hydraulic oil flows through the priority valve waiting on one of the valve functions to be operated.

The hydraulic fluid continues from the priority valve to the brake circuits and the steering circuits. Without any valve functions being operated, steering not turned nor the brakes being pressed, the hydraulic pump destrokes to maintain an output at a control differential pressure of 550 psi. When the pump is on stroke, the hydraulic fluid returns to the hydraulic tank.

Hydraulic System Pressure



WARNING: Hydraulic oil under pressure can cause serious injury. Be sure system is relieved before disconnecting hydraulic fittings.

M650

The hydraulic system is pressurized when the engine is running. Pressure is relieved when the engine is turned off, however, there will be pressure remaining in the hydraulic cylinders. Before working on hydraulic cylinders, turn the engine off and relieve the pressure from the cylinders. Make sure the cylinders are supported prior to any repairs.

Hydraulic Pump

The Telescopic Handler uses a variable displacement pump with a load sensing and pressure compensating feature. The pump will deliver only enough fluid to satisfy load sense pressure difference of 550 psi. The pump will cut-off at 3045 psi maximum.

Frame Level And Fork Tilt Manifold

This manifold contains hydraulic, piloted valves, which control the frame level and fork tilt functions. Fluid is metered to cylinders in proportion to the hydraulic pilot signal supplied from the joystick. The manifold also contains counterbalance valves, which allow the auto-level feature to function. This manifold is the central collection point of the load sense signals.

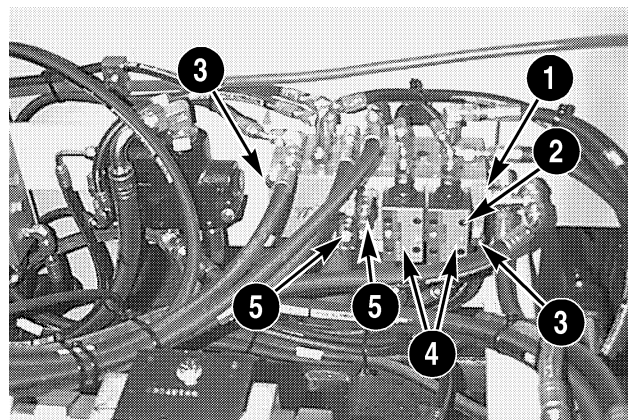

BP98N008

- | | |
|----------------------|------------------------|
| 1. MANIFOLD | 4. PROPORTIONAL VALVES |
| 2. CAP SCREWS | 5. CARTRIDGE VALVES |
| 3. MOUNTING HARDWARE | |

Manifold

TROUBLESHOOTING, HYDRAULIC PUMP

PROBLEM	POSSIBLE CAUSE
The pump makes too much noise	Air in the hydraulic system The bearings or gears are damaged Low oil level in hydraulic tank Wrong oil Supply hose twisted or has a restriction Relief valve is set wrong or is defective Breather or fill screen on hydraulic tank has a restriction Pump is loose or not installed correctly
Low hydraulic pressure	Relief valve is set wrong or is defective Flow regulator valve is defective Leak inside hydraulic cylinder Worn or damaged hydraulic pump Air in the hydraulic system Supply hose twisted or has a restriction Low oil level in hydraulic tank Wrong oil Breather or fill screen on hydraulic tank has a restriction Pump assembled wrong
Pump has leaks	Loose fittings or damaged seals Housing cap screws are loose Pump housing damaged Worn seals and pump shaft
Pump is too hot	Relief valve is set wrong or is damaged Flow regulator valve is defective Worn or damaged hydraulic pump Air in the hydraulic system Wrong oil Breather or fill screen on hydraulic tank has restriction Pump assembled wrong Restriction in hoses to pump
Hydraulic pump wears faster than normal	Dirt in hydraulic system Wrong hydraulic oil Relief valve is set wrong Cavitation from restriction in inlet hose Pump drive is not aligned correctly Pump is not installed correctly in its mount

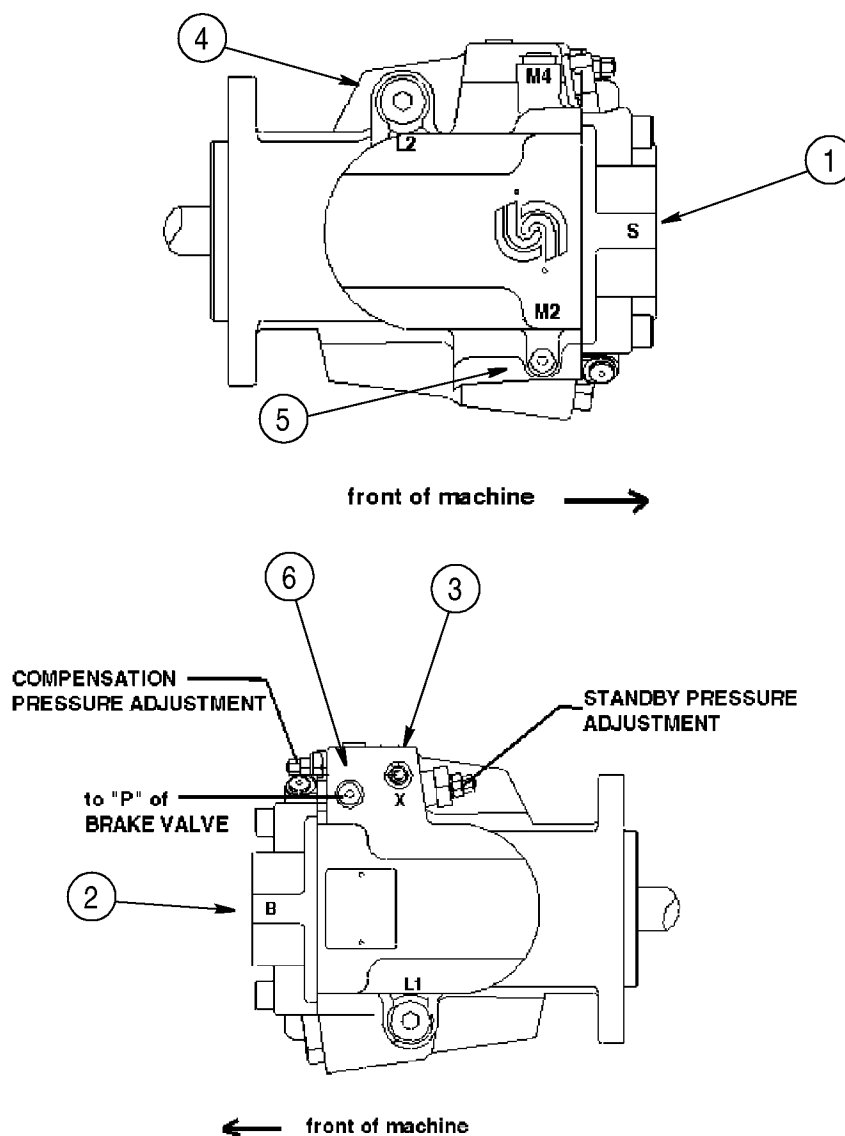

HYDRAULIC PUMP PORT LOCATIONS

BS03A219

- | | |
|---|---|
| 1. S - SUCTION LINE FROM THE HYDRAULIC TANK | 4. L2 - DRAIN LINE TO THE HYDRAULIC TANK |
| 2. B - TO P OF THE PRIORITY VALVE | 5. M2 - PARKING BRAKE SWITCH (PRESSURE TEST PORT) |
| 3. X - TO LS OF THE FRAME LEVEL/FORK TILT/AUXILIARY HYDRAULICS VALVE ASSEMBLY | 6. TO P OF BRAKE VALVE |

The Hydraulic Pump is located at the front of the machine, on top of the transmission. Access the Hydraulic Pump through the engine compartment by sliding the engine cover forward. The Hydraulic Pump is either at its standby pressure (550 psi) or compensation pressure (3045 psi) settings for all functions except for the steering function which is a load sense function.

TROUBLESHOOTING, HYDRAULIC SYSTEM

686GXR P.I.N. JFE0001848 AND AFTER - 688G P.I.N. JFE0003613 AND AFTER

<u>OVERVIEW</u>	
<p>1. The load sensing hydraulic pump is turned on or off (to its compensations pressure setting of 3045psi or, to its standby pressure of 550psi) by a load signal.</p> <p>2. Standby pressure is measured with ALL functions in neutral, and is the difference between pump outlet pressure and “LS Gauge” (frame level/fork tilt manifold) pressure.</p> <p>3. There is a load signal line from the manifold section of the frame level/fork tilt valve assembly (at the LS Pump” port) to the hydraulic pump.</p> <p>4. Every function load signal is prioritized and sorted in this manifold by a series of 3 shuttles.</p> <p>5. The signal line is either drained to tank (Ops) or blocked, which allows the signal pressure to increase to the compensated pressure setting of the pump (3045psi).</p> <p>6. The only exceptions are steering (2175psi) and the optional stabilizers which are true load sense circuits and allow the pump to seek intermediate pressure positions. If ANY other function is activated, the pump goes to its compensated setting of 3045psi.</p>	
<u>FAULT</u>	<u>ACTION & REMEDY</u>
<p>Telescopic handler hydraulic system appears weak. The telescopic handler cannot pick up a known rated load at load centers of 610 mm (24 inches).</p>	<p>ACTION 1: Check pressure at the hydraulic pump M2 port with a 0 to 5000psi gauge. Pressure should be 500 to 600psi at start up. Activate the hydraulic lift function and high pressure stand by should be 3045psi.</p> <p>REMEDY: Test the hydraulic system in accordance with the following procedures.</p>
<u>CHECKS AND ADJUSTMENTS</u>	<u>PROCEDURES</u>
<p>PORT DATA: M2 of the hydraulic pump. PP2 of the drain manifold. LS of the steering priority valve. CF of the steering priority valve. Pressure Reducing Valve of the main hydraulic manifold. BR1 port of the main hydraulic manifold.</p> <p>TOOLS REQUIRED: 3,000psi gauge. 5,000psi gauge. 13mm combination wrench. 6mm hex wrench. 7/32 hex wrench.</p>	<p>NOTE: These tests are to be performed with the F-N-R in neutral and the parking brake applied.</p>

688G SERIES 2 HYDRAULIC SCHEMATIC (OPTIONAL SINGLE JOYSTICK MODELS P.I.N. JFE0003613 AND AFTER)

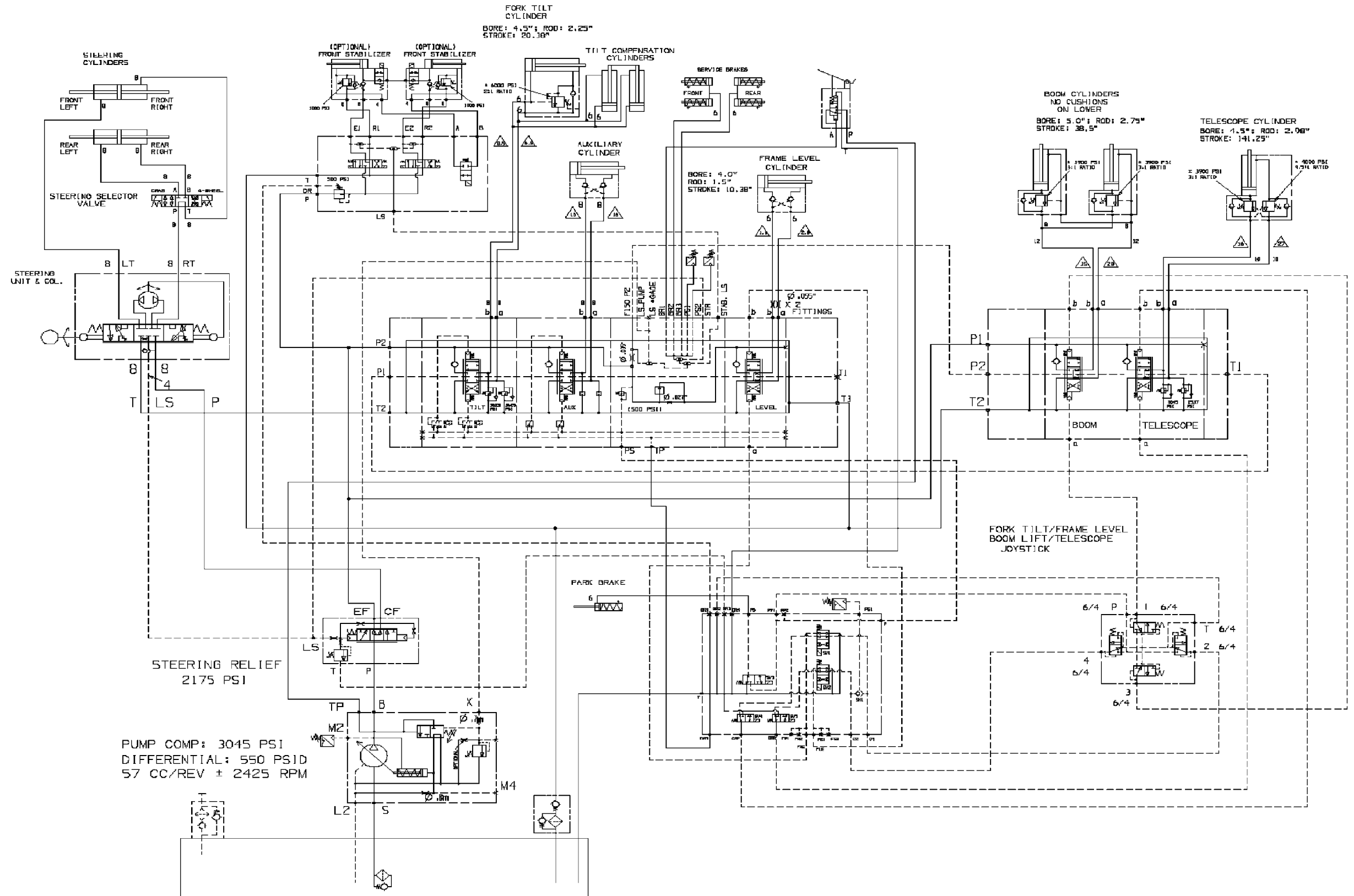

FRAME LEVEL AND FORK TILT MANIFOLD

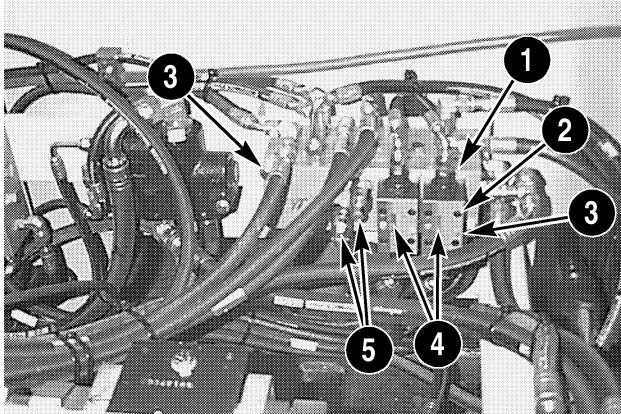

BP98N008

- | | |
|----------------------|------------------------------------|
| 1. MANIFOLD | 4. PROPORTIONAL VALVES |
| 2. CAP SCREWS | 5. COUNTERBALANCE CARTRIDGE VALVES |
| 3. MOUNTING HARDWARE | |

Manifold

Removal



WARNING: Hydraulic oil can be hot and can burn. Allow the machine to cool down prior to repairs.

M674

NOTE: Be sure to have a container, rags, and absorbent material available to capture hydraulic fluid. Dispose of used hydraulic fluid in accordance with established local procedures. Do not allow hydraulic fluid to enter soil.

1. Shut engine off and allow to cool prior to repairs. Remove deck plates to access the manifold.
2. Tag all hoses for reassembly. Disconnect the hoses from remaining adapters. Cap all hoses and adapters.
3. Remove mounting hardware which secures manifold (1) to the frame.

Disassembly

1. Unscrew and remove counterbalance cartridge valves (5).
2. Remove and discard O-rings.
3. Remove cap screws (2) securing proportional valves (4).
4. Remove proportional valves (4).
5. Remove and discard O-rings.

Assembly

1. Coat new O-rings with hydraulic oil position them on proportional valves (4).
2. Place proportional valves (4) on manifold (1). Make sure that O-rings do not move or fall off.
3. Secure proportional valve with cap screws (2). Tighten to 30 Nm (22 lb-ft).
4. Coat new O-rings with hydraulic oil and install them on counterbalance cartridge valves (5).
5. Screw counterbalance cartridge valves (5) into manifold (4). Tighten to 50 Nm (37 lb-ft).

Installation

1. Attach manifold (1) to frame with mounting hardware (3).
2. Attach hoses as noted in step 2 of the removal procedure.
3. Start engine to bring hydraulic pressure up and check for leaks.
4. Operate all hydraulic systems to ensure proper operation before operating machine.

HYDRAULIC CYLINDERS

This section applies to all cylinders on the 686G, 686G XR, and 688G Series 2 Telescopic Handlers. Remove/Install and Disassembly/Assembly tasks are similar for all cylinders. Differences will be noted in applicable task steps.

Removal

WARNING: Do not attempt to work on the hydraulic cylinders with the engine running. Shut off engine and allow system to cool before proceeding.



Do not attempt to remove hydraulic cylinders without providing adequate support to the boom and components. Boom may shift when hydraulic cylinders are disconnected.

M695

Refer to Section 9, Boom, for the procedure to remove and install the hydraulic cylinders.

HYDRAULIC CYLINDER REPAIR

Tear Down (General)

NOTE: Be sure to have a container, rags, and absorbent material available to capture hydraulic fluid. Dispose of used hydraulic fluid in accordance with established local procedures. Do not allow hydraulic fluid to enter soil.

1. Remove the cylinder and drain hydraulic fluid. Thoroughly clean all dirt or other foreign substance from openings, particularly at the head.

NOTE: If excessive wear due to side-loads or binding is a possibility, mark or note the piston and head relationship to the rod and tube. This condition will usually show up as a highly polished surface on the piston and head 90° to the pin rotation axis.

2. Remove the head retaining device. See specific procedures in Section 9, Boom, for the cylinder being repaired.
3. Extend the rod until the piston "bottoms-out" on the head. Gently tap the piston against the head to drive the rod assembly out. Place the rod assembly on a surface that will not damage the chrome. Remove the piston locknut and separate the piston from the rod. Slide the head off the rod from the piston end.
4. Remove and discard all old seals.

Inspection (General)

1. INSPECT ROD: There should be no scratches or pits deep enough to catch the fingernail. Pits that go to the base metal are unacceptable. Scratches that catch the fingernail but are not to the base metal, less than 0.5 inch long and primarily in the circumferential direction are acceptable provided they cannot cut the rod seal. Chrome should be present over the entire surface of the rod and the lack thereof is unacceptable. In the event that an unacceptable condition occurs, the entire cylinder must be replaced.
2. INSPECT HEAD: Visually inspect the inside bore for scratches or polishing. Deep scratches are unacceptable. Polishing indicates uneven loading and when this occurs, the bore should be checked for out-of-roundness. Out-of-roundness exceeding 0.007 inch is unacceptable. Check the condition of the dynamic seals. In particular, look for metallic particles embedded in the seal surface. It is normal to cut the static seal on the retaining ring groove upon disassembly. Remove the rod seal, static O-ring and backup and rod wiper. Damage to the seal grooves, particularly on the sealing surfaces, is unacceptable. In the event that an unacceptable condition occurs, the entire cylinder must be replaced.

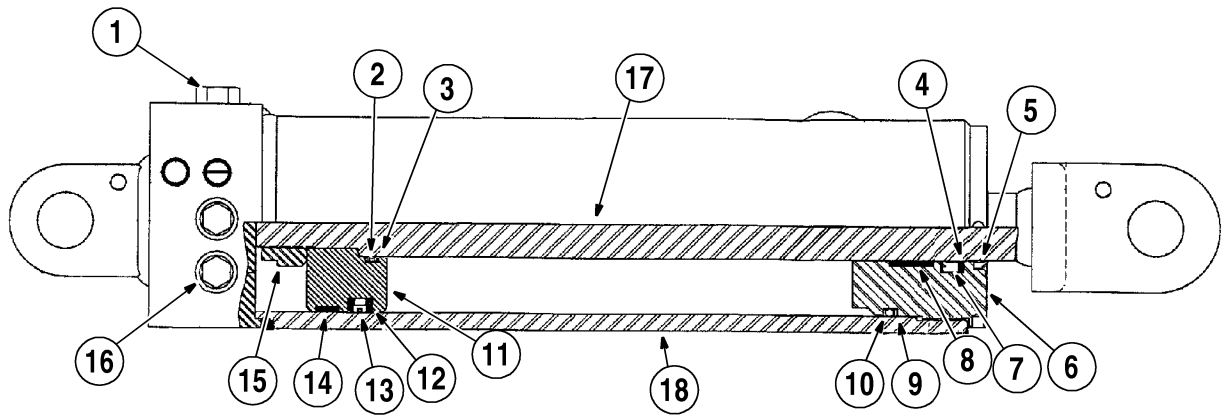

BS98N097

1. CHECK VALVE	7. SEAL	13. SEAL
2. O-RING	8. WEAR RING	14. WEAR RING
3. BACK-UP RING	9. BACK-UP RING	15. LOCKNUT
4. BACK-UP RING	10. O-RING	16. BLEEDER PLUG
5. WIPER	11. PISTON	17. ROD ASSEMBLY
6. HEAD	12. BACK-UP RING	18. TUBE ASSEMBLY

Frame Level Cylinder

Frame Level Cylinder Installation

NOTE: See photo on page 8006-11 for steps 1 and 2.

1. Position the cylinder into the frame weldment. Use a hammer and driver, install pivot pin (5).
2. Install locator pin (3) and secure with cap screw (4).

NOTE: See photo on page 8006-12 for steps 3 and 4.

3. Position top end of cylinder into upper weldment. Use a hammer and driver, install pivot pin (4).
4. Install locator pin (5) and secure with cap screw (6).
5. Reconnect hoses as noted in step 4 of the removal procedure.
6. Remove blocking from front axle and frame stop on each side of the frame.
7. Remove the boom block. Check hydraulic oil level and add hydraulic oil as necessary.
8. Start the engine and operate the frame leveling function. Check for leaks.

Frame Level Cylinder Check Valve Replacement



WARNING: Hydraulic cylinders support heavy loads. Removal of cylinders may cause weight shifts that can result in personal injury. The machine must be properly blocked on both the right and left side to prevent weight shift and tipping prior to removing the frame tilt cylinder.

M696

1. Park the machine on a level surface, block the boom, apply the park brake and stop the engine.
2. Place blocking between the front axle (6) and frame stops (1) on each side of the frame. (See photo on page 8006-11).

NOTE: Be sure to have a container, rags, and absorbent material available to capture hydraulic fluid. Dispose of used hydraulic fluid in accordance with established local procedures. Do not allow hydraulic fluid to enter soil.

3. Crack check valve (7) open to relieve pressure, then remove the check valve. (See photo on page 8006-12).
4. Coat seals on the new valve with hydraulic oil and install check valve in the cylinder. Tighten to 41 to 47 Nm (30 to 35 lb-ft).
5. Remove blocking from front axle, start the engine and operate the frame leveling function. Check for leaks.

MOUNTED EQUIPMENT

Frame Leveling Circuit



WARNING: NEVER actuate the frame leveling lever unless the boom is fully retracted and in the lowered position. The frame must be leveled before raising or extending the boom.

M699

The frame leveling circuit permits the operator to control the lateral angle of the frame so that the telescopic handler is level when the wheels are on a side slope. The shell of the frame leveling cylinder is fastened to the frame of the telescopic handler and the end of the cylinder rod is fastened to the front drive axle. The axle pivots on the axle mount in the center line of the telescopic handler. The frame leveling circuit controls the angle of the frame to the axle by extending or retracting the frame leveling cylinder. The dual check valve (pilot operated) for the frame leveling circuit prevents oil from leaving one end of the cylinder until there is pressure at the other end of the cylinder. This prevents cavitation and permits smooth control of the lateral angle of the telescopic handler frame. The motion control valve also prevents movement of the frame if one of the hoses breaks or if the control lever is moved when the engine is not running.

Boom Assembly

This section contains the description and repair procedures for the Boom Assembly. The removal and installation procedures for the hydraulic cylinders are included in this section. The procedures for disassembly and assembly of the hydraulic cylinders are located in the HYDRAULIC SYSTEMS, Section 8, of this manual. The overall view of the 686G, 686G XR, and 688G Series 2 Telescopic Handler is shown on page 9000-4.

The boom assembly consists of the outer boom section, intermediate boom section, inner boom section, and the crowd cylinder. The boom assembly pivots from the rear on two pins (8) near the rear of the outer boom. The boom assembly is raised and lowered by two boom lift cylinders (6) that are fastened between the boom and the frame of the machine. The boom is controlled by the joystick controller in the operators compartment. The boom components are accessed through the rear cover (7) and the side covers (5) on the outer boom.

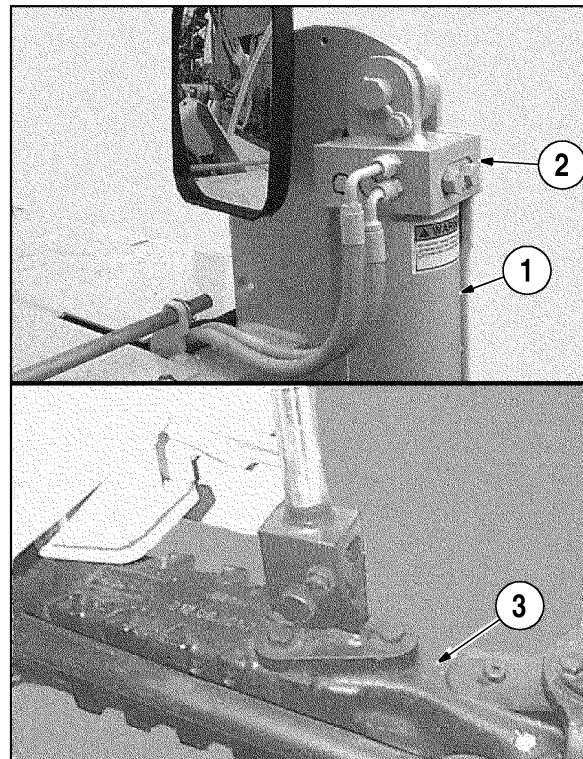
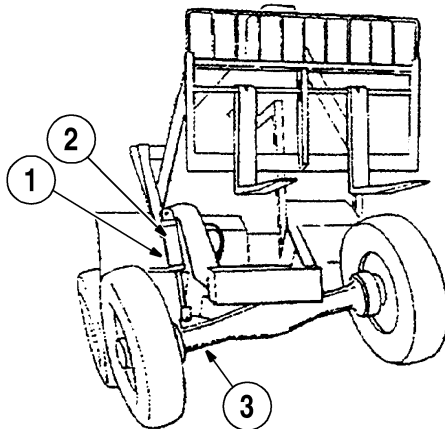

1. FRAME LEVELING CYLINDER

2. DUAL CHECK VALVE

3. DRIVE AXLE

BS99A044

BOOM COMPONENTS REMOVAL AND INSTALLATION

NOTE: The following procedure describes removal and disassembly of the boom components without removing the boom from the machine. The crowd cylinder can be removed from the boom while the boom is mounted to the machine. All of the wear pads can be replaced or adjusted without disassembly of the boom sections. The sheaves,

chains, and hoses can also be removed without disassembly of the boom. The removal and installation of the boom assembly as a unit on the 686G, 686G XR, and 688G is difficult due to its weight and size. Do not remove the boom assembly from the machine unless there is no other way to complete the repair.

CROWD CYLINDER

Removal

1. Start the engine and move the boom assembly to the horizontal position. Fully retract the crowd cylinder and stop the engine.

NOTE: Boom access covers are designed to protect personnel from serious injury and to prevent contamination of internal boom parts. Be sure the telescopic handler power is shutdown before removing covers and working inside of the boom. Never place fingers or hands in boom access holes while the handler is operating. Replace covers after maintenance or service work has been completed.

2. Remove side cover (5) (See page 9000-4) from the outer boom. Remove the cover (1) from the rear of the boom. Remove the three cap screws (2) that hold each cylinder mount block (1, See Cylinder Mount Block) to the intermediate boom through the two rectangular access holes in the outer boom.

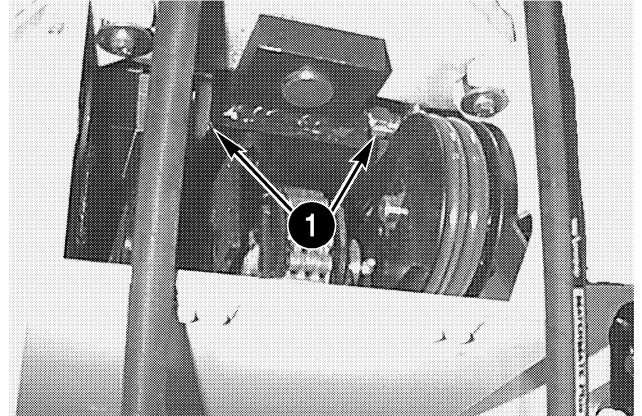

1. CYLINDER MOUNT BLOCK

BP98N015

Cylinder Mount Block

3. Start the engine and extend the boom approximately 1.3 m (4 feet). Stop the engine.

NOTE: Be sure to have a container, rags, and absorbent material available to capture hydraulic fluid. Dispose of used hydraulic fluid in accordance with established local procedures. Do not allow hydraulic fluid to enter soil.

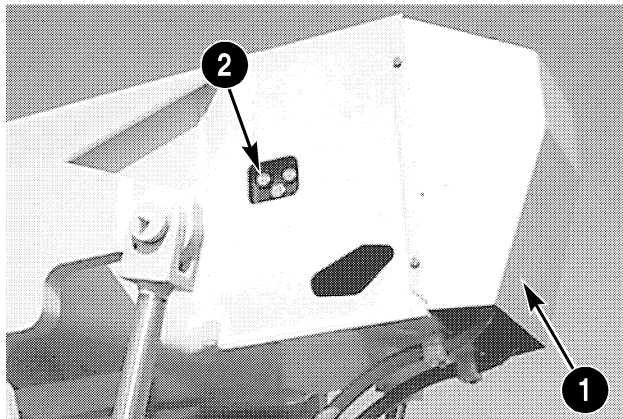

1. REAR COVER
2. CAP SCREWS

BP98N014

Outer Boom

EXTEND CHAIN TOOL

1. Select a 10 to 12 feet long rod 0.375 to 0.50 inch in diameter and weld a 0.25 inch pin to one end. The pin should be small enough to allow insertion into one end of the extend chain that has been disconnected from the chain anchor. Weld a "T" handle to the opposite end.
2. Drill a small hole through the pin to accommodate a cotter pin. This will hold the extend chain securely during installation.

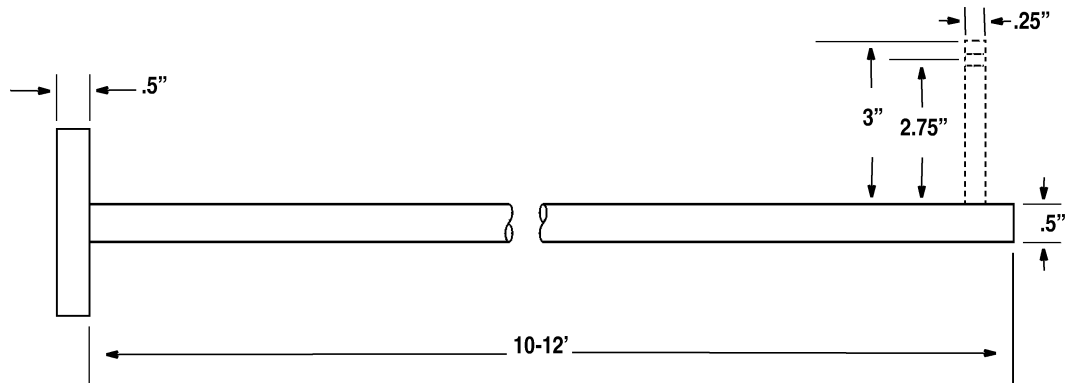

BS98N103

Extend Chain Tool

Extend Chain Installation

1. Attach the replacement chain to the extend chain tool and secure with a cotter pin.
2. Insert the replacement chain through front of inner boom section. Use a pry bar through side access hole to gently lift crowd cylinder so that the chain can be slid under crowd cylinder.
3. Make sure that chain lays flat and does not twist or kink.

NOTE: See diagram on page 9005-12 for steps 4-6.

4. Align the chain with the chain anchor (9). Remove and discard cotter pin from the chain tool and slide the chain off. Remove the tool from the boom and attach the extend chain (5) to chain anchor (9). Insert anchor pin (8) and install new cotter pin (7).
5. Allow enough slack to attach other end of extend chain (5) to chain anchor (6). Insert pin (4) and install new cotter pin (3) to secure extend chain (5) to chain anchor (6).

6. Remove and discard self-locking nut (1) and align chain anchor rod (2) with hole in mount bracket. Pull the extend rod through bracket and install a new self-locking nut (1). Tighten to 115 Nm (85 lbs-ft).
7. Start the engine. Extend and retract the boom to make sure that the chain is operating smoothly and there is no excess slack.
8. Install rear cover, side cover, and front cover.

Cleaning and Inspecting Chains

1. Clean the chain in solvent, then dry, using low pressure compressed air.
2. Place the chain in a pan of SAE 40 engine oil or chain and cable lubricant. Soak the chains in the oil for a minimum of 8 hours to ensure correct lubrication of the pins and links.
3. Dispose of used solvent and oil or lubricant in accordance with established local procedures.

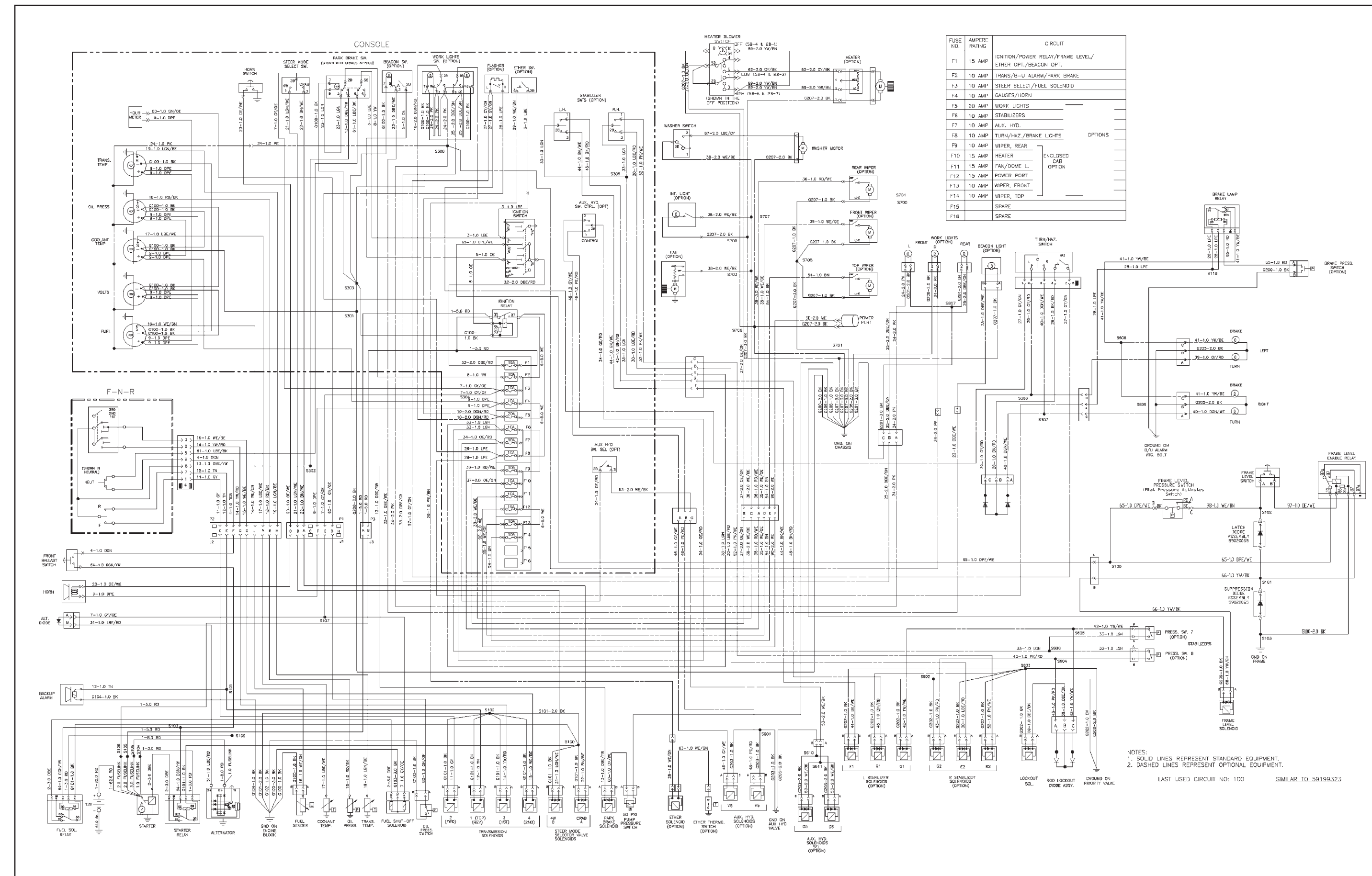

P.I.N. JFE0001848 and after, P.I.N. JFE0003613 and after
 ELECTRICAL SCHEMATIC

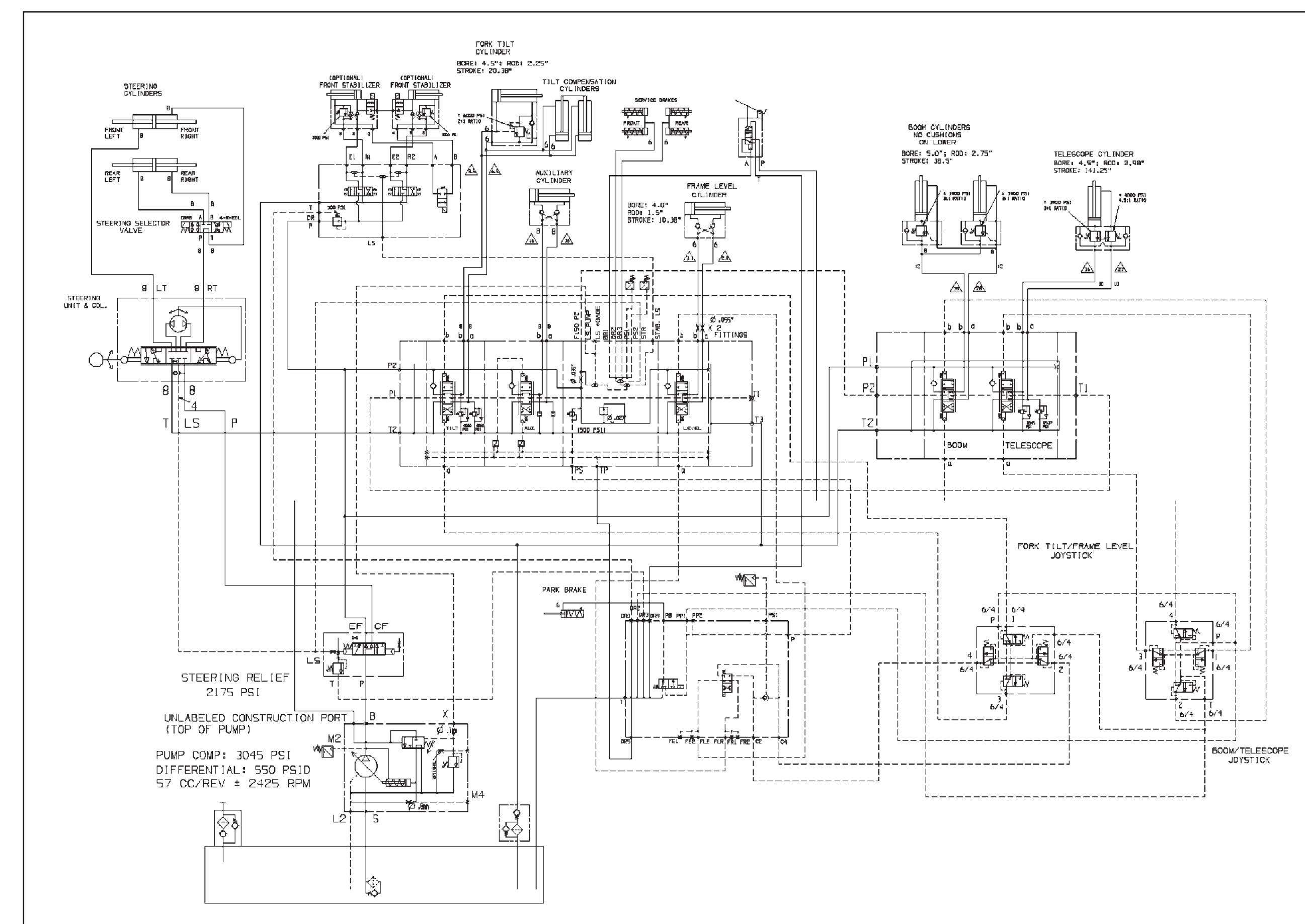
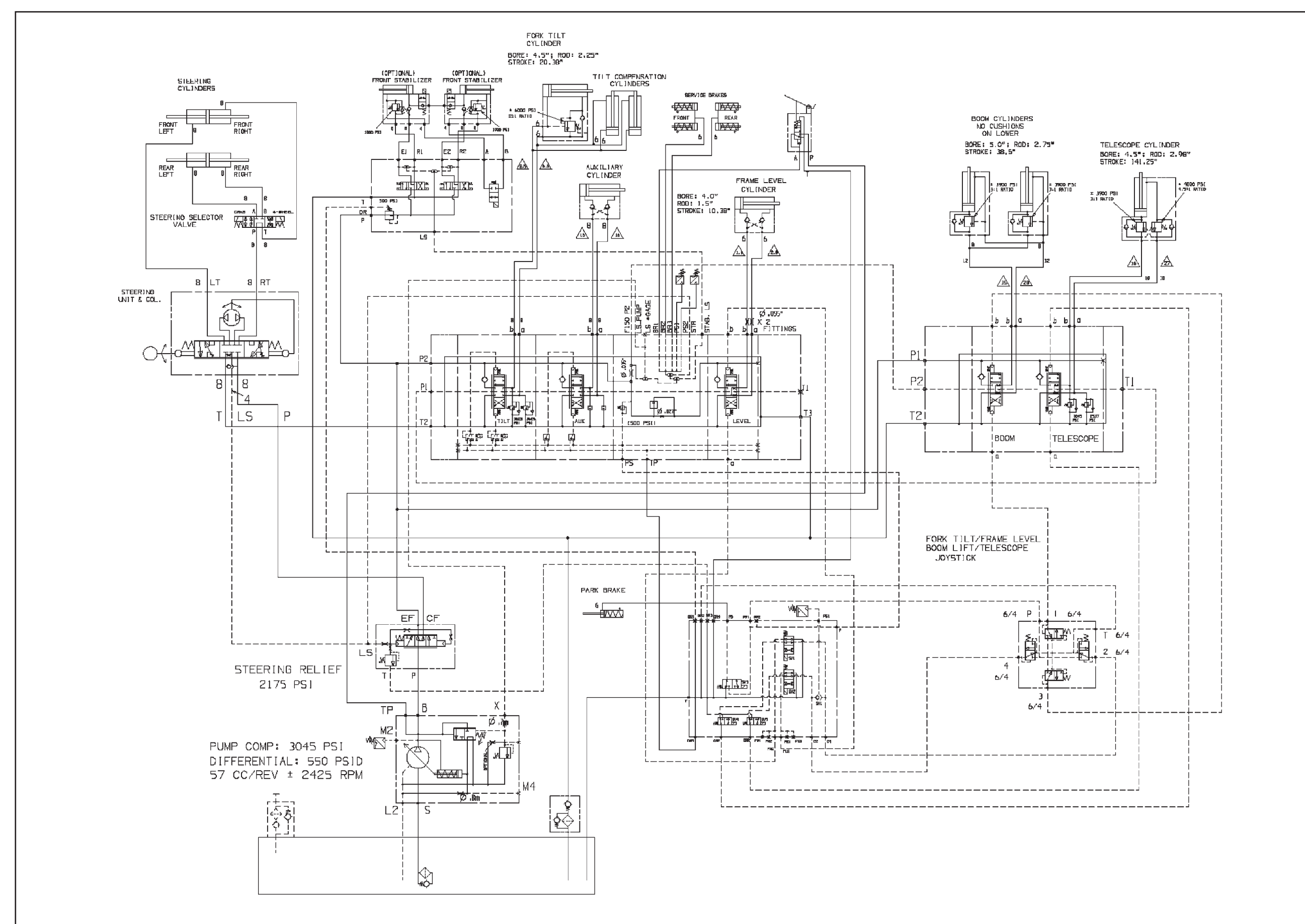

ELECTRICAL AND HYDRAULIC SCHEMATIC
686GXR and 688G Series 2 TELESCOPIC HANDLERS
 Additional copies of this Hydraulic and Electrical Schematic can be ordered through
 Technical Publications Distribution System. The Part Number is 6-49430



**CONVERSION TABLES - TABELLE DI CONVERSIONE - UMRECHNUNGSTABELLEN
TABLAS DE CONVERSION - TABLEAUX DE CONVERSION**

Units of pressure - Unità di pressione - Druckeinheiten
Unidad de presión - Unités de pression: 1 Atm \cong 1 bar \cong 10⁵ Pa \cong 14.4 Psi

Units of weight - Unità di peso - Gewichtseinheiten
Unidad de peso - Unités de poids

Units of torque - Unità di coppia - Drehmomenteinheiten
Unidad de par - Unités de couple

	N	daN	kN	kg	lbs
1N	1	0,1	0,001	0,102	0,225
1daN	10	1	0,01	1,02	2,25
1kN	1000	100	1	102	225
1kg	9,81	0,981	0,00981	1	2,205

	Nm	daNm	kNm	kgm	lb-in
1Nm	1	0,1	0,001	0,102	8,854
1daNm	10	1	0,01	1,02	88,54
1kNm	1000	100	1	102	8854
1kgm	9,81	0,981	0,00981	1	86,8
1lb-in	0,1129	0,01129	0,0001129	0,01152	1

**TIGHTENING TORQUES - COPPIE DI SERRAGGIO - ANZIEHDREHMOMENTE
PARES DE TORSION - COUPLES DE SERRAGE**

Unit - Unità di misura - Meßeinheiten - Unidad de medida - Unités de mesure: Nm

SIZE OF BOLT MISURA VITE SCHRAUBENMASS TAMAÑO TORNILLO MESURE VIS	TYPE OF BOLT - TIPO VITE - GEWINDE - TIPO DE TORNILLO - TYPE DE VIS						
	8.8		10.9		12.9		
	Normali + Loctite 242	Normali + Loctite 270	Normali + Loctite 242	Normali + Loctite 270	Normali + Loctite 242	Normali + Loctite 270	
COARSE PITCH - PASSO GROSSO - GROBER SCHRITT - PASO GRUESO - GROS PAS	M6 x 1	9,5-10,5	10,5-11,5	14,3-15,7	15,2-16,8	16,2-17,8	18,1-20,0
	M8 x 1,25	23,8-26,2	25,6-28,4	34,2-37,8	36,7-40,5	39,0-43,0	43,7-48,3
	M10 x 1,5	48-53	52-58	68-75	73-81	80-88	88-97
	M12 x 1,75	82-91	90-100	116-128	126-139	139-153	152-168
	M14 x 2	129-143	143-158	182-202	200-221	221-244	238-263
	M16 x 2	200-221	219-242	283-312	309-341	337-373	371-410
	M18 x 2,5	276-305	299-331	390-431	428-473	466-515	509-562
	M20 x 2,5	390-431	428-473	553-611	603-667	660-730	722-798
	M22 x 2,5	523-578	575-635	746-824	817-903	893-987	974-1076
	M24 x 3	675-746	732-809	950-1050	1040-1150	1140-1260	1240-1370
	M27 x 3	998-1103	1088-1202	1411-1559	1539-1701	1710-1890	1838-2032
	M30 x 3,5	1378-1523	1473-1628	1914-2115	2085-2305	2280-2520	2494-2757
	FINE PITCH - PASSO FINE - KLEINER SCHRITT PASO FINO - PAS FIN	M8 x 1	25,7-28,3	27,5-30,5	36,2-39,8	40,0-44,0	42,8-47,2
M10 x 1,25		49,4-54,6	55,2-61,0	71,5-78,5	78,0-86,0	86,0-94,0	93,0-103,0
M12 x 1,25		90-100	98-109	128-142	139-154	152-168	166-184
M12 x 1,5		86-95	94-104	120-132	133-147	143-158	159-175
M14 x 1,5		143-158	157-173	200-222	219-242	238-263	261-289
M16 x 1,5		214-236	233-257	302-334	333-368	361-399	394-436
M18 x 1,5		312-345	342-378	442-489	485-536	527-583	580-641
M20 x 1,5		437-483	475-525	613-677	674-745	736-814	808-893
M22 x 1,5		581-642	637-704	822-908	903-998	998-1103	1078-1191
M24 x 2		741-819	808-893	1045-1155	1140-1260	1235-1365	1363-1507
M27 x 2		1083-1197	1178-1302	1520-1680	1672-1848	1834-2027	2000-2210
M30 x 2		1511-1670	1648-1822	2138-2363	2332-2577	2565-2835	2788-3082



- ITA** Pulire accuratamente il pistone (9) e le sedi di scorrimento e tenuta.
Sostituire le guarnizioni OR (11) e (12) e gli anelli antiestrusione (13) e (14), rispettando il senso di montaggio.
ATTENZIONE! Controllare attentamente il posizionamento degli anelli antiestrusione (13) e (14).
- D** Kolben (9) sowie Gleit- und Dichtungssitze sorgfältig reinigen.
O-Ringe (11) und (12) sowie die Halteringe (13) und (14) auswechseln; dabei auf die Reihenfolge der Montage achten.
ACHTUNG! Position der Halteringe (13) und (14) sorgfältig kontrollieren.
- ESP** Limpiar minuciosamente el pistón (9) y los alojamientos de deslizamiento y estanqueidad.
Sustituir las juntas OR (11) y (12) y los anillos antiextrusión (13) y (14) teniendo en cuenta el sentido de montaje.
CUIDADO! Controlar atentamente el posicionamiento de los anillos antiextrusión (13) y (14).
- F** Nettoyer soigneusement le piston (9), les logements de coulissement et d'étanchéité.
Remplacer les garnitures OR (11) et (12), les anneaux anti-extrusion (13) et (14) en respectant le sens du montage.
ATTENTION! Contrôler soigneusement la position des anneaux anti-extrusion (13) et (14).
- ITA** Lubrificare le guarnizioni (11) e (12) e montare nel braccio (3) il pistone (9).
ATTENZIONE! Controllare che la sede del pistone imbocchi la spina di arresto (A) interna al braccio.
- D** Dichtungen (11) und (12) schmieren und Arm (3) und Kolben (9) montieren.
ACHTUNG! Der Kolben muß den Anhaltestift (A) im Inneren des Arms aufnehmen.
- ESP** Lubricar las juntas (11) y (12) y montar en el brazo (3) el pistón (9).
CUIDADO! Controlar que el alojamiento del pistón encaje en la clavija de tope (A) dentro del brazo.
- F** Lubrifier les garnitures (11) et (12), puis monter dans le bras (3) le piston (9).
ATTENTION! Contrôler que le logement du piston s'emboîte bien avec la broche d'arrêt (A) à l'intérieur du bras.
- ITA** Montare le viti a perno (10) controllando che siano tutte dello stesso colore. Bianco: gioco 1 mm
Giallo: gioco 0,75 mm
Azzurro: gioco 0,5 mm.
Spalmare la filettatura con Loctite 270.
Coppia di serraggio: 5÷7 Nm
- D** Die Stiftschrauben (10) einsetzen. Diese müssen alle gleichfarbig sein. Weiß: Spiel 1 mm
Gelb: Spiel 0,75 mm
Hellblau: Spiel 0,5 mm.
Das Gewinde mit Loctite 270 schmieren.
Anzugsmoment: 5÷7 Nm.
- ESP** Montar los pernos roscados (10) controlando que sean todos del mismo color. Blanco: juego 1 mm
Amarillo: juego 0,75 mm
Azul: juego 0,5 mm.
Pasar en la rosca Loctite 270.
Par de torsión: 5÷7 Nm.
- F** Monter les vis à tourillon (10) en contrôlant si elles sont toutes de ma même couleur. Blanc: jeu 1 mm
Jaune: jeu 0,75 mm
Bleu ciel: jeu 0,5 mm.
Enduire le filetage de Loctite 270.
Couple de serrage: 5÷7 Nm.
- ITA** Inserire a filo del pistone (9) le molle (15) per l'autoregolazione della corsa.
- D** Den Kolben (9) und die Federn (15) zur Selbstregelung des Hubs genau einsetzen.
- ESP** Introducir a ras del pistón (9) los muelles (15) para la autorregulación de la carrera.
- F** Introduire, au fil du bord du piston (9) les ressorts (15) pour l'autorégulation de la course.
- ITA** Aiutare l'inserimento del pistone (9) con leggeri colpi di mazzuolo in materiale plastico distribuiti lungo la circonferenza.
- D** Den Kolben (9) einsetzen; diesen dazu leicht mit einem Gummihammer entlang seiner Kreislinie schlagen.
- ESP** Facilitar la inserción del pistón (9) con ligeros golpes de martillo de material plástico distribuidos en toda la circunferencia.
- F** Accompagner l'introduction du piston (9) par de légers coups de maillet en matière plastique distribués tout le long de la circonférence.
- ITA** Montare le molle (8) di ritorno del pistone (9).
ATTENZIONE! Usare molta cautela per non deformare gli attacchi delle molle.
- D** Die Rückzugsfedern (8) des Kolbens (9) montieren.
ACHTUNG! Sehr vorsichtig vorgehen, um die Federn am Anschluß nicht zu verformen.
- ESP** Montar los muelles (8) de retorno del pistón (9).
CUIDADO! Tener mucho cuidado a fin de no deformar las uniones de los muelles.
- F** Monter les ressorts (8) de retour du piston (9).
ATTENTION! Faire très attention à ne pas déformer les raccords des ressorts.



- a**
- ITA** Serrare in sequenza con il metodo incrociato, le nuove viti (3) di ritegno dei perni snodo inferiore e superiore. Coppia di serraggio: 128÷142 Nm
 - D** Entgegengesetzt und abwechselnd die Schrauben (3) der unteren und oberen Gelenkstiften festschrauben. Anzugsmoment: 128÷142 Nm
 - ESP** Apretar en secuencia con el método cruzado, los tornillos (3) de retención de las rótulas inferior y superior.
Par de torsión: 128÷142 Nm
 - F** Serrer dans l'ordre, par le biais du mode croisé, les vis (3) de fixation des tourillons d'articulation inférieur et supérieur.
Couple de serrage: 128÷142 Nm

- b**
- ITA** Collegare il perno snodo (2) (Vedere «INSTALLAZIONE CILINDRO DI STERZATURA»).
Lubrificare gli snodi con Molikote e montare il coperchio parapolvere (1).
 - D** Den Gelenkstift (2) anschließen (Siehe «GELENKZYLINDER INSTALLIEREN»).
Gelenke mit Molikote schmieren und den Schutzdeckel (1) abschrauben.
 - ESP** Conectar la rótula (2) (Véase «INSTALACION CILINDRO DE DIRECCION»).
Lubricar las rótulas con Molikote y montar la tapa de protección del polvo (1).
 - F** Brancher le tourillon d'articulation (2) (Voir «INSTALLATION DU CYLINDRE DE BRAQUAGE»).
Lubrifier les articulations avec du Molikote, puis monter le couvercle anti-poussière (1).

CLICK HERE TO **DOWNLOAD** THE COMPLETE MANUAL

- Thank you very much for reading the preview of the manual.
- You can download the complete manual from: www.heydownloads.com by clicking the link below



- Please note: If there is no response to CLICKING the link, please download this PDF first and then click on it.

CLICK HERE TO **DOWNLOAD** THE COMPLETE MANUAL



- a**
- ITA** Scaldare in olio il cuscinetto a circa 100°C ed infilare sul doppio giunto cardanico (4) la bussola completa (13).
 - D** Lager in Öl auf ca. 100°C erhitzen und auf die Doppelgelenkwelle (4) die komplette Buchse (13) schieben.
 - ESP** Calentar en aceite el cojinete a unos 100°C e introducir en el semieje (4) el manguito completo (13).
 - F** Chauffer dans l'huile à environ 100°C le palier puis enfiler sur le joint de cardan double (4) la douille complète (13).

- b**
- ITA** Montare l'anello di ritegno (9) del gruppo bussola (13); posizionare anche la guarnizione OR (14).
 - D** Haltering (9) des Buchsenaggregats (13) montieren; O-Ring (14) ebenfalls montieren.
 - ESP** Montar el anillo de retención (9) del grupo del manguito (13); posicionar también la junta OR (14).
 - F** Monter l'anneau de retenue (9) du groupe douille (13); placer également la garniture OR (14).

- c**
- ITA** Infilare il doppio giunto cardanico e serrare i grani superiore ed inferiore (2).
Coppia di serraggio: Max. 15 Nm.
NOTA. Per il doppio giunto cardanico con bussola, centrare la punta dei grani di ritegno nella cava.
 - D** Doppelgelenkwelle einsetzen und obere und untere Stifte (2) festschrauben.
Anzugsmoment: Max. 15 Nm
BEMERKUNG. Bei der Doppelgelenkwelle mit Buchse, Stiftpitze genau zentrieren.
 - ESP** Introducir el semieje y apretar la espiga superior y la inferior (2).
Par de torsión: Máx. 15 Nm.
NOTA. Para el semieje con manguito, centrar la punta de las espigas de retención en la ranura.
 - F** Enfiler le joint de cardan double et serrer les grains supérieurs et inférieurs (2).
Couple de serrage: Max. 15 Nm.
NOTE. Pour le joint de cardan double à douille, centrer la pointe des grains de fixation dans le creux.

- d**
- ITA** Spalmare con Loctite 242 le porzioni sporgenti dei grani (2).
 - D** Mit Loctite 242 die herausragenden Stifte (2) schmieren.
 - ESP** Pasar Loctite 242 en las partes salientes de las espigas (2).
 - F** Enduire de Loctite 242 les parties saillantes des grains (2).

- e**
- ITA** Avvitare i dadi (3) di bloccaggio dei grani (2) e bloccarli con chiave dinamometrica.
Coppia di serraggio: 122 Nm
 - D** Muttern (3) zur Befestigung der Stifte (2) zuschrauben und mit einem Momentenschlüssel blockieren.
Anzugsmoment: 122 Nm
 - ESP** Atornillar las tuercas (3) de bloqueo de las espigas (2) y bloquearlas con llave dinamométrica.
Par de torsión: 122 Nm
 - F** Visser les écrous (3) de blocage des grains (2), puis bloquer à l'aide d'une clé dynamométrique.
Couple de serrage: 122 Nm



- a**
- ITA** Lubrificare la bronzina (18) e la sede della scatola snodo (3).
Utilizzando l'attrezzo T7 montare la bronzina (18).
- D** Das Bronzelager (18) und das Gelenkgehäuse (3) schmieren.
Mit einem Werkzeug T7 das Bronzelager (18) montieren.
- ESP** Lubricar la chumacera (18) y el alojamiento de la caja de la rótula (3).
Montar la chumacera (18) utilizando la herramienta T7.
- F** Lubrifier le coussinet (18) et le logement du boîtier articulation (3).
A l'aide de l'outil T7 monter le coussinet (18).

- c**
- ITA** Posizionare sotto la pressa la parte inferiore dell'attrezzo T9A e la ralla del cuscinetto esterno (8).
- D** Unter einer Presse den unteren Teil des Werkzeugs T9A und die Scheibe des äußeren Lagers (8) positionieren.
- ESP** Posicionar debajo de la prensa la parte inferior de la herramienta T9A y la rangua del cojinete exterior (8).
- F** Placer sous la presse la partie inférieure de l'outil T9A et la crapaudine du palier externe (8).

- e**
- ITA** Posizionare la parte superiore dell'attrezzo T9B e pressare a fondo le ralle nel mozzo portaruota (7).
- D** Das obere Teil des Werkzeugs T9B positionieren und die Scheiben in die Radhalternabe (7) fest eindrücken.
- ESP** Posicionar la parte superior de la herramienta T9B y presionar a fondo las ranguas en el cubo portarruedas (7).
- F** Placer la partie supérieure de l'outil T9B, puis presser à fond les crapaudines du moyeu porte-roue (7).

- b**
- ITA** Lubrificare la superficie esterna dell'anello di tenuta (17) e dell'anello centratore (16); montarli in sede utilizzando l'attrezzo T8.
- D** Die äußere Fläche des Kolbenringes (17) und des Zentrierringes (16) schmieren; die beiden Ringe mit einem Werkzeug T8 montieren.
- ESP** Lubricar la superficie exterior del segmento de compresión (17) y del anillo de centrado (16); montarlos en un alojamiento utilizando la herramienta T8.
- F** Lubrifier la surface externe de la bague d'étanchéité (17), et de l'anneau de centrage (16), puis monter ceux-ci dans leur logement à l'aide de l'outil T8.

- d**
- ITA** Lubrificare le sedi dei cuscinetti e posizionare sull'attrezzo T9A il mozzo portaruota (7); posizionare la ralla del cuscinetto interno (15).
NOTA. Controllare l'orientamento della ralla.
- D** Die Lagersitze schmieren und am Werkzeug T9A die Radhalternabe (7) positionieren; die Scheibe des inneren Lagers (15) positionieren.
BEMERKUNG. Die Position der Scheibe beachten.
- ESP** Lubricar los alojamientos de los cojinetes y posicionar en la herramienta T9A el cubo portarruedas (7); posicionar la rangua del cojinete interior (15).
NOTA. Controlar la orientación de la rangua.
- F** Lubrifier le logement des paliers et placer sur l'outil T9A le moyeu porte-roue (7); placer la crapaudine du palier interne (15).
NOTE. Contrôler les sens de la crapaudine.

- f**
- ITA** Montare il cuscinetto (15) nella ralla interna.
- D** Lager (15) in die innere Scheibe montieren.
- ESP** Montar el cojinete (15) en la rangua interior.
- F** Monter le palier (15) dans la crapaudine interne.



- a**
- ITA** Asportare le viti (8) di fissaggio del cilindro di sterzata (9).
- D** Die Befestigungsschrauben (8) des Lenkzylinders (9) abnehmen.
- ESP** Sacar los tornillos (8) que fijan el cilindro de dirección (9).
- F** Enlever les vis (8) de fixation du cylindre de braquage (9).

- b**
- ITA** Estrarre il cilindro (9) utilizzando un mazzuolo in materiale plastico.
NOTA. Per lo smontaggio del cilindro, vedere «SMONTAGGIO CILINDRO DI STERZATURA».
- D** Den Zylinder (9) mit einem Gummihammer heraus-schlagen.
BEMERKUNG. Um den Zylinder abzumontieren, siehe «LENKZYLINDER ABMONTIEREN».
- ESP** Extraer el cilindro (9) utilizando un martillo de material plástico.
NOTA. Para desmontar el cilindro, véase «DESMONTAJE CILINDRO DE DIRECCION».
- F** Extraire le cylindre (9) à l'aide d'un maillet en matière plastique.
NOTE. Pour démonter le cylindre, voir «DEMONTAGE DU CYLINDRE DE BRAQUAGE».

THIS PAGE IS INTENTIONALLY LEFT BLANK

- a**
- ITA** Rimuovere gli anelli elastici (16) dai perni (17) degli ingranaggi satelliti (18).
- D** Kolbenringe (16) von den Stiften (17) der Planetenräder (18) entfernen.
- ESP** Remover los anillos elásticos (16) de los dos pernos (17) de los engranajes satélites (18).
- F** Enlever les anneaux élastiques (16) des tourillons (17) des engrenages satellites (18).

- b**
- ITA** Inserire tra gli ingranaggi satelliti (18) l'attrezzo T14.
- D** Zwischen den Planetenrädern (18) das Werkzeug T14 einsetzen.
- ESP** Introducir entre los engranajes satélites (18) la herramienta T14.
- F** Introduire entre les engrenages satellites (18) l'outil T14.

- c**
- ITA** Operando con due cacciaspine, forzare l'attrezzo T14 tra gli ingranaggi satelliti (18).
ATTENZIONE! Controllare attentamente che l'attrezzo T14 rimanga allineato ai perni (17) quando è bloccato.
- D** Mit zwei Dübeln, das Werkzeug T14 zwischen den Planetenrädern (18) fest einsetzen.
ACHTUNG: Sorgfältig darauf achten, daß das blockierte Werkzeug T14 mit den Stiften (17) fluchtgerecht ist.
- ESP** Trabajando con dos extractores de clavijas, forzar la herramienta T14 entre los engranajes satélite (18).
CUIDADO! Controlar atentamente que la herramienta T14 quede alineada con los pernos (17) cuando está bloqueada.
- F** En oeuvrant avec deux chasse-goupilles, forcer l'outil T14 entre les engrenages satellites (18).
ATTENTION! Contrôler attentivement si l'outil T14 reste aligné aux tourillons (17) quand il est bloqué.

- d**
- ITA** Sistemare il corpo differenziale (15) sotto una pressa, posizionare la boccola T15 ed inserire lo spinotto T16A. Pressare lo spinotto T16A fino a fondo corsa.
- D** Das Differentialgehäuse (15) unter eine Presse legen und die Buchse T15 positionieren; Bolzen T16A einsetzen. Drücken, bis der Bolzen T16A.
- ESP** Colocar la caja del diferencial (15) debajo de una prensa; posicionar el casquillo T15 e introducir la cruceta T16A. Presionar la cruceta T16A.
- F** Ajuster le boîtier différentiel (15) sous la presse, placer la bague T15 et introduire le goujon T16A. Presser le goujon T16A.

- e**
- ITA** Asportare lo spinotto T16A e la bussola T15.
NOTA. In questa condizione, il perno (17) è contenuto nell'attrezzo T14.
- D** Bolzen T16A und die Buchse T15 abnehmen.
BEMERKUNG. In diesem Zustand, ist der Stift (17) im Werkzeug T14 enthalten.
- ESP** Sacar la cruceta T16A y el manguito T15.
NOTA. En esta condición el perno (17) se encuentra en la herramienta T14.
- F** Enlever le goujon T16A et la douille T15.
NOTE. Dans cette condition le tourillon (17) se trouve dans l'outil T14.

- f**
- ITA** Rimuovere l'attrezzo T14 e con esso il perno (17) del satellite.
- D** Das Werkzeug T14 und damit den Stift (17) des Planetenrades abnehmen.
- ESP** Remover la herramienta T14 y con ella el perno (17) del satélite.
- F** Enlever l'outil T14 et, avec ce dernier, le tourillon (17) du satellite.



ITA **NOTA.** Se le ghiera (1) vengono rimosse, spalmarle con Loctite 242.
Serrare le ghiera dal lato corona fino ad azzerare i giochi tra pignone e corona e bloccarla; ritornare indietro di circa 1/4÷1/2 giro.

D **BEMERKUNG.** Wenn die Nutmutter (1) ausgewechselt werden, diese mit Loctite 242 schmieren.
Nutmutter an der Kranzseite fest ziehen bis kein Spiel mehr zwischen Rad und Kranz übrig bleibt; danach um 1/4÷1/2 Umdrehung wieder aufschrauben.

ESP **NOTA.** Si se remueven las virolas (1) pasarles Loctite 242.
Apretar las virolas del lado corona hasta acerar los juegos entre el piñon y la corona y bloquearla, volver atrás de 1/4÷1/2 giro approx.

F **NOTE.** Si les anneaux (1) sont enlevés, les enduire avec du Loctite 242.
Serrer les anneaux de fixation du côté couronne jusqu'à mettre à zéro les jeux entre pignon et couronne et bloquer: revenir en arrière d'environ 1/4÷1/2 tour.

ITA Posizionare, attraverso il foro per il tappo superiore (10), un comparatore a tasto orientabile "A".
Posizionarlo sul centro di un dente della corona (12), precaricarlo di circa 1 mm ed azzerarlo.

D Durch das Loch des oberen Stopfens (10) eine schwenkbare Meßuhr "A" in der Mitte eine Kranzzahnes (12) anbringen. Die Meßuhr auf 1 mm vorladen und auf Null stellen.

ESP Posicionar, a través del orificio para el tapón superior (10), un comparador de tecla orientable "A".
Posicionarlo en el centro de un diente de la corona (12), precargarlo de aproximadamente 1 mm y ponerlo a cero.

F Placer, par le trou du bouchon supérieur (10), un comparateur à touche orientable "A".
Placer ce dernier au centre d'une dent de la couronne (12), précharger d'environ 1 mm, puis le mettre à zéro.

ITA Regolare il gioco tra pignone e corona allentando una ghiera (1) e serrando la ghiera opposta in egual misura.
Gioco normale: vedere tabella.

D Das Spiel zwischen Rad und Kranz einstellen; dazu eine Nutmutter (1) lockern und die entgegengesetzte Nutmutter auf dieselbe Weise zuschrauben.
Normales Spiel: siehe Tabelle.

ESP Regular el juego entre el piñón y la corona aflojando una virola (1) y apretando la virola opuesta en la misma medida.
Juego normal: véase la tabla.

F Régler le jeu entre pignon et couronne en desserrant un collier de serrage (1) puis en serrant le collier de serrage opposé avec la même mesure de jeu.
Jeu normal: voir tableau.

ITA Precaricare i cuscinetti tramite la ghiera lato opposto corona per incrementare la coppia di rotazione pignone fino a 140÷210 Ncm.

ATTENZIONE! Con cuscinetti usati, controllare la coppia di spunto; con cuscinetti nuovi, controllare la coppia di rotazione continua.

D Lager durch die Nutmutter an der dem Kranz entgegengesetzten Seite vorladen, um das Gegenmoment des Rades auf 140÷210 Ncm zu bringen.

ACHTUNG! Bei verbrauchten Lagern, das Anlaufdrehmoment kontrollieren; bei neuen Lagern, das kontinuierliche Drehmoment kontrollieren.

ESP Precargar los cojinetes a través de la virola lado opuesto corona para incrementar el par de rotación pinon hasta 140÷210 Ncm.

CUIDADO! Con cojinetes usados, controlar el par de inicio, con cojinetes nuevos, controlar el par de rotación continua.

F Précharger les paliers au moyen d'anneaux de fixation du côté opposé de la couronne pour augmenter le couple de rotation pignon jusqu'à 140÷210 Ncm.

ATTENTION! Avec les paliers usés, contrôler le couple de pointe; avec les paliers neufs, contrôler le couple de rotation continu.

ITA Muovere manualmente nei due sensi la corona (12) per controllare il gioco esistente tra pignone e corona.

D Den Kranz (12) von Hand in beide Richtungen bewegen und das Spiel zwischen Rad und Kranz prüfen.

ESP Mover manualmente en los dos sentidos la corona (12) para controlar el juego que hay entre el piñón y la corona.

F Déplacer la couronne (12) manuellement dans les deux sens pour contrôler le jeu existant entre pignon et couronne.

ITA Utilizzando un piano di riscontro, azzerare sull'anello di misura T24 (di spessore conosciuto pari a 30,2 mm) un comparatore centesimale "DG".
Precaricare il comparatore di circa 2 mm.

D Mit Hilfe eines Anslags am Meßring T24 (bekannte Stärke 30,2 mm) eine hundertteilige Meßuhr "DG" auf Null stellen.
Meßuhr auf 2 mm vorladen.

ESP Utilizando una superficie para la comparación, poner a cero en el anillo de medida T24 (del que se conoce el espesor igual a 30,2 mm) un comparador centesimal "DG".
Precargar el comparador en 2 mm aproximadamente.

F A l'aide d'un plan de comparaison, mettre à zéro sur l'anneau de mesurage T24 (d'une épaisseur connue égale à 30,2 mm), un comparateur centésimal "DG".
Précharger le comparateur d'environ 2 mm.

ITA Portare sotto il comparatore "DG" il cuscinetto interno (9) completo di ralla.
Determinare lo spessore totale "D" del cuscinetto controllando lo scostamento rispetto la misura dell'anello di misura.
ATTENZIONE! Premere la ralla in modo centrato ed eseguire più volte la misurazione ruotando la ralla.

D Unter die Meßuhr "DG" das innere Lager (9) samt Scheibe legen.
Gesamte Stärke "D" des Lagers messen und die Abweichung im Verhältnis zum Meßring kontrollieren.
ACHTUNG! Die Scheibe muß zentriert sein und den Meßvorgang mehrmals bei gedrehter Scheibe wiederholen.

ESP Poner debajo del comparador "DG" el cojinete interior (9) con la rangua.
Determinar el espesor total "D" del cojinete controlando la diferencia con respecto al tamaño del anillo de medida.
CUIDADO! Presionar la rangua de manera centrada y ejecutar varias veces la medida girando la rangua.

F Amener sous le comparateur "DG" le palier interne (9) équipé de crapaudine.
Définir l'épaisseur totale "D" du palier en contrôlant l'écart par rapport à celle mesurée par l'anneau de mesurage.
ATTENTION! Presser la crapaudine vers le centre, puis en effectuer plusieurs fois le mesurage en tournant la crapaudine.

ITA Inserire parzialmente nel corpo centrale (12) la ralla del cuscinetto esterno (13).

D Auf den zentralen Körper (12) die Scheibe des äußeren Lagers (13).

ESP Introducir parcialmente en el cuerpo central (12) la rangua el cojinete exterior (13).

F Introduire, partiellement dans le corps central (12), la crapaudine du palier externe (13).

ITA Montare il tirante T25C, l'anello di misura T24, ed infine l'attrezzo anteriore T25A di guida della ralla (13) del cuscinetto esterno.

D Die Spannstange T25C, den Meßring T24, und zuletzt das vordere Werkzeug T25A zur Führung der Scheibe (13) des äußeren Lagers montieren.

ESP Montar el tirante T25C, el anillo de medida T24, y por último la herramienta anterior T25A guía de la rangua (13) del cojinete exterior.

F Monter la tringle T25C, l'anneau de mesurage T24, et enfin l'outil antérieur T25A de guidage de la crapaudine (13) du palier externe.

ITA Collegare il tirante alla pressa e mandare in sede la ralla del cuscinetto esterno (13).
Scollegare la pressa e rimuovere il tirante.
NOTA. Prima di proseguire, assicurarsi dell'inserimento totale della ralla.

D Spannstange mit der Presse verbinden und die Scheibe in ihren Sitz im äußeren Lager (13) einsetzen.
Von der Presse abnehmen und Spannstange abnehmen.
BEMERKUNG. Sorgfältig kontrollieren, ob die Scheibe richtig eingesetzt worden ist.

ESP Conectar el tirante a la prensa y colocar en el alojamiento la rangua del cojinete exterior (13).
Sacar la prensa y remover el tirante.
NOTA. Antes de continuar, asegurarse de que la rangua está completamente insertada.

F Brancher la tringle à la presse, puis envoyer dans son logement la crapaudine du palier externe (13).
Débrancher la presse et enlever la tringle.
NOTE. Avant de continuer, s'assurer que la crapaudine est complètement insérée.

ITA Inserire l'attrezzo T26B completo di cuscinetto esterno (13) anello di misura T24 e ghiera di altezza calibrata T26C.
Serrare a fondo manualmente.

D Werkzeug T26B mit dem äußeren Lager (13), Meßring T24 und in der Höhe kalibrierte Nutmutter T26C einsetzen.
Von Hand festschrauben.

ESP Introducir la herramienta T26B con el cojinete exterior (13), el anillo de medida T24 y la virola de altura calibrada T26C.
Apretar a fondo manualmente.

F Introduire l'outil T26C équipé du palier externe (13), l'anneau de mesurage T24 et le collier de serrage de hauteur tarauté T26C.
Serrer à fond manuellement.



- a**
- ITA** Lubrificare la superficie esterna del nuovo anello di tenuta (6) e montarlo nel corpo centrale (12) utilizzando l'attrezzo T27.
 - D** Die äußere Fläche des neuen Ringes (6) schmieren und den zentralen Körper (12) mit Hilfe des Werkzeugs T27 montieren.
 - ESP** Lubricar la superficie exterior del nuevo segmento de compresión (6) y montarlo en el cuerpo central (12) utilizando la herramienta T27.
 - F** Lubrifier la surface externe de la bague d'étanchéité neuve (6), puis monter celle-ci dans le corps central (12) à l'aide de l'outil T27.

- b**
- ITA** Montare il supporto oscillante (5).
NOTA: Controllare attentamente l'orientamento.
 - D** Die schwenkbare Halterung (5) montieren.
BEMERKUNG: Richtung sorgfältig kontrollieren.
 - ESP** Montar el soporte oscilante (5).
NOTA: Controlar atentamente la orientación.
 - F** Monter le support oscillant (5).
NOTE: Contrôler attentivement le sens.

- c**
- ITA** Montare la flangia (2) completa della protezione (4) e mandarla in battuta.
Se necessario, per il calettamento della flangia (2), usare un mazzuolo in materiale plastico.
NOTA: Controllare che la protezione (4) sia ben forzata sulla flangia e che non sia deformata.
 - D** Flansch (2) samt Schutzteil (4) montieren und bis zum Anschlag bringen.
Wenn nötig, den Flansch (2) mit einem Gummihammer einschieben.
BEMERKUNG: Kontrollieren ob das Schutzteil (4) richtig auf dem Flansch sitzt und nicht verformt ist.
 - ESP** Montar la brida (2) con su protección (4) y llevarla hasta el tope.
Si fuera necesario, para ensamblar de la brida (2) usar un martillo de material plástico.
NOTA: Controlar que la protección (4) está bien forzada en la brida y que no está deformada.
 - F** Monter la flasque (2) équipée de protection (4), puis envoyer celle-ci en butée.
Si besoin, pour caler la flasque (2) utiliser un maillet en matière plastique.
NOTE: Veiller à ce que la protection (4) est bien forcée sur la flasque et qu'elle n'est pas déformée.

- d**
- ITA** Spalmare la porzione filettata del pignone (8) con Loctite 242.
Montare l'attrezzo T20A (oppure T20B) ed impegnarlo per evitare la rotazione. Montare l'anello OR (3) ed il dado (1); serrare con chiave dinamometrica.
Coppia di serraggio: 280÷310 Nm
 - D** Das Gewinde des Rads (8) mit Loctite 242 schmieren. Das Werkzeug T20A (T20B) montieren und blockieren, damit es nicht drehen kann.
O-Ring (3) und Mutter (1) montieren und mit einem Momentenschlüssel festschrauben.
Anzugsmoment: 280÷310 Nm
 - ESP** Pasar en la parte roscada del piñón (8) Loctite 242. Montar la herramienta T20A (o T20B) y bloquearla para evitar la rotación.
Montar el anillo OR (3) y la tuerca (1) y apretarlos con llave dinamométrica.
Par de torsión: 280÷310 Nm
 - F** Enduire la partie fileté du pignon (8) avec du Loctite 242. Monter et fixer l'outil T20A (ou T20B) pour éviter la rotation.
Monter le OR (3) et l'écrou (1), puis serrer à l'aide de la clé dynamométrique.
Couple de serrage: 280÷310 Nm

- e**
- ITA** Asportare i blocchi T23 montati per l'estrazione del pignone e rimontare i bracci.
Per i dettagli, vedere «CONTROLLO USURA E SOSTITUZIONE DISCHI FRENO».
 - D** Blöcke T23 abnehmen, die zum Herausnehmen des Rads montiert wurden und Arme wieder montieren.
Siehe «VERSCHLEISS KONTROLLIEREN UND BREMSSCHEIBEN AUSWECHSELN».
 - ESP** Sacar los bloques T23 montados para la extracción del piñón y volver a montar los brazos.
Para los detalles, véase «CONTROL DEL DESGASTE Y SUSTITUCION DE LOS DISCOS DEL FRENO».
 - F** Enlever les blocs T23 montés pour l'extraction des pignons, puis remonter les bras.
Pour de plus amples détails, voir «CONTROLE DE L'USURE ET SUBSTITUTION DES FREINS».



PROBLEM - PROBLEMA - PROBLEM - PROBLEMA - PROBLEME	CAUSE - CAUSE - URSACHE - CAUSAS - CAUSE	CORRECTION - RIMEDI - ABHILFE - REMEDIOS - REMEDE
Soft brake pedal <i>Pedale del freno non risponde</i> Leichtes Bremspedal <i>El pedal del freno no funciona</i> Pedale du frein ne repond pas	6. Air in brake circuit <i>6. Aria nel circuito frenante</i> 6. Luft in der Bremsanlage <i>6. Aire en el circuito frenante</i> 6. Air dans le circuit	Bleed brakes as described in the vehicle's service manual. <i>Spurgare il circuito frenante come da istruzioni di spurgo del manuale del veicolo.</i> Bremsen entlüften gemäß Anweisungen im Handbuch des Fahrzeuges. <i>Purgar el circuito frenante se acuerdo con las instrucciones de purga del manual del vehículo.</i> Purger le circuit de frein selon «instructions de purge» du manuel du véhicule.
Ineffective safety brake <i>Freno negativo inefficiente</i> Federspeicherbremse ohne Funktion. <i>Freno negativo ineficiente</i> Inefficacite du frein negatif	7. Incorrect adjustment <i>7. Registrazione incorretta</i> 7. Fehlerhafte Einstellung des Bremsscheibenspieles <i>7. Ajuste incorrecto</i> 7. Mauvais réglage	See correction N. 1. <i>Vedere rimedio N. 1.</i> Siehe Abhilfe N. 1. <i>Véase remedio N.1.</i> Voir remède N. 1.
	8. Brake disc worn out <i>8. Dischi freno usurati</i> 8. Bremslamellen verschlissen <i>8. Discos del freno gastados</i> 8. Usure disques frein	See correction N. 2. <i>Vedere rimedio N. 2.</i> Siehe Abhilfe N. 2. <i>Véase remedio N. 2.</i> Voir remède N. 2.
Overheating <i>Surriscaldamento</i> Überhitzung <i>Sobrecalentamiento</i> Surchauffe	9. Oil level wrong <i>9. Livello olio non corretto</i> 9. Niedriger Ölspiegel-Falscher Ölstand <i>9. Nivel de aceite no correcto</i> 9. Niveau d'huile pas incorrect	Drain, flush and refill oil to proper level. <i>Scaricare, eseguire un lavaggio e riempire d'olio fino a livello.</i> Öl ablassen, reinigen und richtigen Ölstand wieder herstellen. <i>Descargar, ejecutar un lavado y llenar con aceite hasta el nivel.</i> Vidanger, rincer et refaire le niveau d'huile.
	10. Too small of a brake gap <i>10. Poco gioco tra i dischi freno</i> 10. Zu wenig Spiel zwischen den Bremslamellen <i>10. Poco juego entre los discos del freno</i> 10. Peu de jeu entre les disques frein	Readjust brakes to the specifications in the vehicle's service manual. <i>Registare il freno come istruzioni da manuale del veicolo.</i> Spiel gemäß Anweisungen im Handbuch des Fahrzeuges herstellen. <i>Ajustar el freno de acuerdo con las instrucciones del manual del vehículo</i> Regler le frein selon les instructions du manuel du véhicule.
	11. Park brake dragging <i>11. Freno di parcheggio in trazione</i> 11. Feststellbremse zieht <i>11. Freno de estacionamiento en tracción</i> 11. Frein de parc mal réglé	Unlock the brake and adjust the correct gap. <i>Sbloccare il freno ripristinando il gioco corretto.</i> Bremsen lösen und richtiges Lamellenspiel einstellen. <i>Desbloquear el freno restableciendo el juego correcto.</i> Débloquer le frein et régler le jeu.



ITA **NOTA.** Lo smontaggio è uguale per i due bracci e può essere eseguito solo a leve (3) libere.
Scollegare dalla scatola snodo il tirante di sterzata.
Per i dettagli, vedere «RIMOZIONE CILINDRO DI STERZATURA».

D **BEMERKUNG.** Beide Arme werden auf dieselbe Weise abmontiert; dies kann jedoch nur erfolgen, wenn die Hebel (3) frei sind.
Spannstange vom Gelenkgehäuse abtrennen.
Weitere Einzelheiten im Paragraph «LENKZYLINDER ABMONTIEREN».

ESP **NOTA** El desmontaje es igual por los dos brazos y puede ser efectuado solo a palancas (3) libres.
Desconectar del carter de las rotulas el tirante de direccion.
Para los detalles, vease «REMOCION CILINDRO DE DIRECCION».

F **NOTE.** Le démontage est pareil pour les deux bras et ne peut être effectué que lorsque les leviers (3) sont libres.
Débrancher de la boîte articulation la tringle de braquage.
Pour tout détail, voir «DEPOSE CYLINDRE DE BRAQUAGE».

ITA Asportare la vite (1) di bloccaggio della rondella (2) di ritegno della leva (3).

D Die Schraube (1) zur Befestigung der Unterlegscheibe (2) des Hebels (3) abschrauben.

ESP Sacar el tornillo (1) de bloqueo de la arandela (2) de retencion palanca (3).

F Enlever la vis (1) de blocage de la rondelle (2) de fixation du levier (3).

ITA Rimuovere la rondella (2), la leva (3) e le guarnizioni OR (4).
Contrassegnare le posizioni delle leve (3) rispetto le leve di spinta (12) e (13).

D Unterlegscheibe (2), Hebel (3) und O-Ringe (4) abnehmen.
Die Positionen der Hebel (3) im Verhältnis zu den Druckhebeln (12) und (13) kennzeichnen.

ESP Remover la arandela (2), la palanca (3) y las guarniciones OR (4).
Senalar las posiciones de las palancas (3) respecto a las palancas de empuje (12)

F Enlever la rondelle (2), le levier (3) et les garnitures OR (4).
Marquer les positions des leviers (3) par rapport aux leviers (12) et (13).

ITA Asportare le viti (5) e rimuovere la boccola (6) completa di guarnizione OR (7).

D Schrauben (5) abschrauben und Buchse (6) samt O-Ring (7) abnehmen.

ESP Sacar los tornillos (5) y remover el casquillo (6) completo de guarniciones OR (7).

F Enlever les vis (5) et extraire la douille (6) équipée de garnitures OR (7).

ITA Agganciare il braccio completo (8) ad un mezzo di sollevamento e mettere il leggera tensione la fune.
Rimuovere il braccio completo; per i dettagli, vedere «CONTROLLO E SOSTITUZIONE DISCHI FRENI».

D Vollständigen Arm (8) mit einem Hebekarren anheben bis das Seil gespannt ist.
Vollständigen Arm abtrennen; weitere Einzelheiten im Paragraph «BREMSSCHEIBEN KONTROLLIEREN UND AUSWECHSELN».

ESP Enganchar el brazo completo (8) y un medio de levantamiento y poner en ligera tension el cable.
Remover el brazo completo; por los detalles, vease «CONTROL Y SUSTITUCION DISCOS FRENOS».

F Accrocher le bras complet (8) à un moyen de relevage et mettre la corde légèrement en tension.
Enlever le bras complet; pour tout détail, voir «CONTROLE ET SUBSTITUTION DES DISQUES FREINS».

ITA Rimuovere i dischi freni (9) ed il pistone completo (10).
Per i dettagli, vedere «CONTROLLO E SOSTITUZIONE DISCHI FRENI».

D Bremsscheiben (9) und den ganzen Kolben (10) abnehmen. Weitere Einzelheiten im Paragraph «BREMSSCHEIBEN KONTROLLIEREN UND AUSWECHSELN».

ESP Remover los discos frenos (9) y el piston completo (10).
Por los detalles, vease «CONTROL Y SUSTITUCION DISCOS FRENOS».

F Enlever les disques freins (9) et le piston complet (10).
Pour tout détail, voir «CONTROLE ET SUBSTITUTION DES DISQUES FREINS».



ITA Immettere lentamente il raccordo del corpo cilindro (9) per espellere il pistone (13).
ATTENZIONE! Trattene il pistone che può essere espulso velocemente ed essere danneggiato.

D Langsam das Anschlußstück des Zylinderkörpers (9) einsetzen, um den Kolben (13) auszustoßen.
ACHTUNG! Den Kolben halten, denn er könnte plötzlich herausspringen und beschädigt werden.

ESP Meter lentamente el empalme del cuerpo cilindro (9) para la expulsion del piston (13).
ATENCION! Tener el piston que puede ser expulso rapidamente y danarse.

F Introduire lentement le raccord du corps cylindre (9) et expulser le piston (13).
ATTENTION! Retenir le piston qui expulsé rapidement peut par conséquent s'endommager.

ITA Rimuovere dal pistone (13) le guarnizioni (14) e l'anello di guida (15).
NOTA. Annotare il senso di montaggio delle guarnizioni.

D Den Kolben (13), die Dichtungen (14) und den Führungsring (15) abnehmen.
BEMERKUNG. Montagerichtung der Dichtungen bemerken.

ESP Remover del piston (13) las guarniciones (14) y el anillo de guia (15).
NOTA. Anotar el sentido de desmontaje de las guarniciones.

F Enlever du piston (13) les garnitures (14) et la bague de guidage (15).
NOTE. Prendre note du sens de montage des garnitures.

ITA **SOLO SE NECESSARIO**
Rimuovere dalla sede molla (10) l'anello di guida (11).
ATTENZIONE! Se l'anello di guida (11) viene smontato, deve essere sostituito.

D **NUR WENN NOTWENDIG**
Aus dem Federsitz (10) den Führungsring (11) nehmen.

ACHTUNG! Falls der Führungsring (11) abmontiert wird, muß er ausgewechselt werden.

ESP **SOLO SI NECESARIO**
Remover de la sede muelle (10) el anillo de guia (11).
ATENCION! Si el anillo de guia (11) viene desmontado, debe de ser substituido.

F **SEUL SI BESOIN**
Enlever du siège ressort (10), la bague de guidage (11).
ATTENTION! Si la bague de guidage (11) est démontée, il faut la substituer.



- a**
- ITA** Rimuovere dal pistone (23) le guarnizioni (24) e l'anello di guida (25).
NOTA. Annotare il senso di montaggio delle guarnizioni.
- D** Den Kolben (23) und die Dichtungen (24) sowie den Führungsring (25) abnehmen.
BEMERKUNG. Montagerichtung der Dichtungen merken.
- ESP** Remover del pistón (23) las guarniciones (24) y el anillo de guía (25).
NOTA. Anotar el sentido de desmontaje de las guarniciones.
- F** Enlever le piston (23), les garnitures (24) et la bague de guidage (25).
NOTE. Noter le sens du montage des garnitures

- b**
- ITA** **SOLO SE NECESSARIO**
Rimuovere dalla sede molla (20) l'anello di guida (21).
ATTENZIONE! Se l'anello di guida (21) viene smontato, deve essere sostituito.
- D** **NUR WENN NÖTIG**
Vom Federsitz (20) den Führungsring (21) abnehmen.
ACHTUNG! Wird der Führungsring (21) abmontiert, muß er ausgewechselt werden.
- ESP** **SOLO SI FUERA NECESARIO**
Remover del alojamiento muelle (20) el anillo de guía (21).
ATENCIÓN! Si el anillo de guía (21) viene desmontado, debe de ser substituido.
- F** **SEULEMENT SI BESOIN**
Enlever du siège ressort (20) la bague de guidage (21).
ATTENTION! Une fois la bague de guidage (21) démontée, elle doit être substituée.



- a**
- ITA** Rimuovere l'anello di tenuta (12) e scartarlo.
NOTA. Annotare il senso di montaggio.
- D** Dichtung (12) abnehmen und nicht mehr verwenden.
BEMERKUNG. Montagerichtung bemerken.
- ESP** Remover la junta (12) y descartarla.
NOTA. Anotar el sentido de montaje.
- F** Enlever la garniture (12) puis l'éliminer.
NOTE. Prendre note du sens du montage.

- c**
- ITA** Rimuovere il supporto freno (14).
- D** Bremsenhalterung (14) abnehmen.
- ESP** Remover el soporte del freno (14).
- F** Enlever le support du frein (14).

- b**
- ITA** Rimuovere le viti (13) di fissaggio del supporto freno (14).
- D** Schrauben (13) zur Befestigung der Bremsenhalterung (14) abschrauben.
- ESP** Remover los tornillos (13) de fijación del soporte del freno (14).
- F** Enlever les vis (13) de fixation du support du frein (14).

- d**
- ITA** Rimuovere il distanziale (15).
NOTA. Se si deve intervenire sul gruppo pignone conico, vedere il paragrafo specifico dell'assale.
- D** Distanzstück (15) abnehmen.
BEMERKUNG. Falls Eingriffe am Kegelrad nötig sind, siehe entsprechender Abschnitt betreffend Achsen.
- ESP** Remover el separador (15).
NOTA. Si hay que intervenir en el grupo piñón cónico, véase el apartado específico del eje.
- F** Enlever l'entretoise (15).
NOTE. Si on doit intervenir sur le groupe pignon conique, voir le paragraphe concernant spécifiquement l'essieu.



ITA SOLO PER VERSIONE A 3 FUNZIONI
Rimuovere le molle (32) di ritorno del pistone (33).

D NUR FÜR AUSFÜHRUNG MIT 3 FUNKTIONEN
Rückzugsfeder (32) des Kolbens (33) abnehmen.

ESP SOLO POR VERSION A 3 FUNCIONES
Sacar los muelles (32) de vuelta del piston (33).

F SEULEMENT DANS LES VERSIONS A 3 FONCTIONS.
Enlever les ressorts (32) de retour du piston (33).

ITA SOLO PER VERSIONE A 3 FUNZIONI
Immettere lentamente aria compressa attraverso l'attacco del freno di servizio per estrarre il pistone (33).
ATTENZIONE! Trattenerne il pistone (33) che può essere espulso velocemente ed essere danneggiato.

D NUR FÜR AUSFÜHRUNG MIT 3 FUNKTIONEN
Langsam Druckluft durch den Anschluß der Hilfsbremse einlassen, um den Kolben (33) auszustoßen.

ACHTUNG! Den Kolben (33) halten, denn er könnte plötzlich herausgestoßen und beschädigt werden.

ESP SOLO POR VERSION A 3 FUNCIONES
Introducir lentamente aire comprimida através el ataque del freno de servicio para sacar el piston (33).
ATENCIÓN. Tener el piston (33) que puede ser expulsado rápidamente y ser danado.

F SEULEMENT DANS LES VERSIONS A 3 FONCTIONS.
Emettre lentement de l'air comprimé à travers le point de montage du frein de service pour en extraire le piston (33).
ATTENTION! Retenir le piston (33) qui expulsé rapidement peut être par conséquent endommagé.

ITA SOLO PER VERSIONE A 2 FUNZIONI
Asportare il distanziale (39).

D NUR FÜR AUSFÜHRUNG MIT 2 FUNKTIONEN
Distanzstück (39) abnehmen.

ESP SOLO POR VERSION A 3 FUNCIONES
Sacar el distancial (39).

F SEULEMENT DANS LES VERSIONS A 2 FONCTIONS.
Enlever l'entretoise (39).

ITA Rimuovere dal coperchio (8) l'anello di tenuta (38).
NOTA. Annotare il senso di montaggio dell'anello (38) e sostituirlo ad ogni smontaggio.

D Vom Deckel (8) den Dichtring (38) abnehmen.
BEMERKUNG. Montagerichtung des Ringes (38) bemerken und beim Abmontieren jedesmal auswechseln.

ESP Remover de la tapa (8) el segmento de compresión (38).
NOTA. Anotar el sentido de montaje del segmento (38) y substituirlo cada desmontaje.

F Enlever du couvercle (8) la bague d'étanchéité (38).
NOTE. Prendre note du sens de montage de la bague (38), la remplacer à chaque démontage.

ITA Rimuovere dal pistone (12) gli anelli di tenuta (13) e (15) e gli anelli antiestrusione (14) e (16).
NOTA. Gli anelli di tenuta (13), (15) ed antiestrusione (14), (16) devono essere sostituiti ad ogni smontaggio.

D Vom Kolben (12) Dichtringe (13) und (15) sowie die Halteringe (14) und (16) abnehmen.
BEMERKUNG. Die Dichtringe (13), (15) und Halteringe (14), (16) müssen bei jedem Abmontieren ausgewechselt werden.

ESP Sacar el piston (12) los segmentos de compresión (13) y (15) y los segmentos anti-extrusión (14) y (16).
NOTA. Los segmentos de compresión (13) y (15) y anti-extrusión (14), (16) deben de ser cambiados cada desmontaje.

F Enlever le piston (12) les bagues d'étanchéité (13) et (15) et les anneaux anti-extrusion (14), et (16).
NOTE. Les bagues d'étanchéité (13), (15) et anti-extrusion (14), (16) doivent être remplacées à chaque démontage.

ITA SOLO PER VERSIONE A 3 FUNZIONI
Rimuovere dal pistone (33) gli anelli di tenuta (34) e (36) e gli anelli antiestrusione (35) e (37).
NOTA. Gli anelli di tenuta (34), (36) ed antiestrusione (35), (37) devono essere sostituiti ad ogni smontaggio.

D NUR FÜR AUSFÜHRUNG MIT 3 FUNKTIONEN
Vom Kolben (33) die Dichtringe (34) und (36) sowie die Halteringe (35) und (37) abnehmen.
BEMERKUNG. Die Dichtringe (34), (36) und Halteringe (35), (37) jedesmal auswechseln, wenn sie abmontiert werden.

ESP SOLO POR VERSION DE 3 FUNCIONES
Remover del piston (33) los segmentos de compresión (34) y (36) y los segmentos anti-extrusión (35) y (37).
NOTA. Los segmentos de compresión (34), (36) y anti-extrusión (35), (37) deben de ser substituidos a cada desmontaje.

F SEULEMENT DANS LES VERSIONS A 3 FONCTIONS.
Enlever du piston (33) les bagues d'étanchéité (34) et (36) et les anneaux anti-extrusion (35) et (37).
NOTE. Les bagues d'étanchéité (34), (36) et anti-extrusion (35), (37) doivent être remplacées à chaque démontage.



ITA Spalmare il piano di appoggio del distanziale (23) con Loctite 510.
Montare sul pignone il gruppo dischi-mozzo-distanziale preparato nelle fasi precedenti e mandarlo in battuta.

D Die Auflagefläche des Distanzstückes (23) mit Loctite 510 schmieren.
Auf den Kolben das Aggregat Scheiben-Nabe-Distanzstück montieren, das zuvor vorbereitet wurden und bis zum Anschlag einsetzen.

ESP Pasar la superficie de apoyo del distancial (23) con Loctite 510.
Montar sobre el pinón el grupo discos-cubo-distancial preparado en la fase precedente y mandarlo a tope.

F Enduire le plan d'appui de l'entretoise (23) avec du Loctite 510.
Monter sur le pignon le groupe disques-moyeu-entretoise préparé lors des phases précédentes et l'envoyer en butée.

ITA Inserire le viti (17) ed avvitare a fondo in modo incrociato; serrarle con una coppia di 9,5÷10,5 Nm.
NOTA. Prima del serraggio finale, allineare le superfici esterne dei componenti.

D Schrauben (17) einsetzen und bis zum Anschlag im Kreuz mit einem Anzugsmoment von 9,5÷10,5 Nm fest schrauben.

BEMERKUNG. Bevor die Teile endgültig festgezogen werden, die äußeren Flächen ausrichten.

ESP Introducir los tornillos (17) y atomillarlos a tope de manera cruzada; apretarlos con un par de 9,5÷10,5 Nm.
NOTA. Antes de apretarlos definitivamente, alinear las superficies exteriores de los componentes.

F Introduire les vis (17) et visser à fond de façon croisée; serrer celles-ci à un couple de 9,5÷10,5 Nm.
NOTE. Avant le serrage final, aligner les surfaces externes des composants.

ITA **SOLO PER VERSIONE A 2 FUNZIONI**
Montare sul coperchio (8) l'anello di battuta (10) delle molle a tazza, rilevare la misura "B" e trascriverla.
Rilevare la misura "A" necessaria al calcolo dei rasamenti (9) con la formula: $S = A - (B + 18,4)$ ove: S = Spessori rasamenti - 18,4 mm = misura fissa delle molle a tazza.

D **NUR FÜR AUSFÜHRUNG MIT 2 FUNKTIONEN**
Auf den Deckel (8) den Anschlagring (10) der Tellerfedern montieren. Das Maß "B" messen und anmerken.
Das Maß "A" messen, das zur Rechnung der Scheiben (9) mit nachstehender Formel nötig ist: $S = A - (B + 18,4)$ wo: S = Scheibenstärke - 18,4 mm = feste Maß für Tellerfedern.

ESP **SOLO POR VERSION A 2 FUNCIONES**
Montar sobre la tapa (8) el segmento a tope (10) de los muelles a taza, relevar la medida "B" y registrarla.
Relevar la medida "A" necesaria al calculo de las raspaduras (9) con la formula: $S = A - (B + 18,4)$ donde: S = espesor raspaduras - 18,4 mm = medida fija de los muelles a taza.

F **SEULEMENT DANS LES VERSIONS A 2 FONCTIONS.**
Monter sur le couvercle (8) l'anneau de butée (10) des ressorts Belleville, relever la mesure "B" et enregistrer cette dernière. Relever la mesure "A" nécessaire pour calculer les rasages (9) avec la formule: $S = A - (B + 18,4)$ ou: S = Cales rasages - 18,4 mm = mesure fixe des ressorts Belleville.

ITA Lubrificare la guarnizione OR (24) e montare il cilindro (18) completo di pistone (12).

D O-Ring (24) schmieren und den Zylinder (18) samt Kolben (12) montieren.

ESP Lubrificar la guarnición OR (24) y montar el cilindro (18) completo de pistón (12).

F Lubrifier la garniture OR (24) et monter le cylindre (18) équipé du piston (12).

ITA **SOLO PER VERSIONE A 2 FUNZIONI**
Utilizzando un mazzuolo in materiale plastico, mandare a fondo corsa il pistone (12).

D **NUR FÜR AUSFÜHRUNG MIT 2 FUNKTIONEN**
Mit einem Gummihammer den Kolben (12) bis zum Anschlag schlagen.

ESP **SOLO POR VERSION A 2 FUNCIONES**
Utilizando un martillo en material plastico, mandar a final carrera el pistón (12).

F **SEULEMENT DANS LES VERSIONS A 2 FONCTIONS.**
A l'aide du maillet en matière plastique, envoyer le piston (12) en fin de course.

ITA Lubrificare leggermente gli spessori (9) calcolati e l'anello (10) di battuta delle molle a tazza.
Montare spessori ed anello sul coperchio (8).
NOTA. Posizionare lo spessore maggiore a ridosso del coperchio.

D Die Scheiben (9) und den Anschlagring (10) der Tellerfedern leicht schmieren.
Scheiben und Ring auf den Deckel (8) montieren.
BEMERKUNG. Die größere Scheibe sollte am Deckel anliegen.

ESP Lubrificar ligeramente los espesores (9) calculados y el segmento (10) a tope de los muelles a taza.
Montar el espesor mayor detras de la tapa.
NOTA. Colocar el espesor mayor detras de la tapa.

F Lubrifier légèrement les cales (9) calculées et l'anneau (10) de butée des ressorts Belleville.
Monter cales et anneau sur le couvercle (8).
NOTE. Placer la cale la plus grande au-dessus du couvercle.



- a**
- ITA** Rimuovere l'attrezzo **T14** ed asportare dal corpo differenziale (9) gli ultimi due ingranaggi satelliti (12), il 2° ingranaggio planetario (6) ed il relativo gruppo di frizione (7) completo.
- D** Das Werkzeug **T14** abnehmen und vom Differentialkörper (9) die letzten beiden Zahnräder des Planetengetriebes (12), das 2. Planetengetriebe und das entsprechende Kupplungsaggregat (7) abnehmen.
- ESP** Remover la herramienta **T14** y sacar del cuerpo diferencial (9) los últimos dos engranajes satelites (12), el 2° engranaje planetario (6) y el relativo grupo de frición (7) completo.
- F** Enlever l'outil **T14** puis extraire du corps différentiel (9) les deux derniers engrenages satellites (12), le 2° engrenage planétaire (6) et le groupe de friction relatif (7) complet.



ITA Rimuovere le viti (14) e rimuovere il coperchio intermedio (13).
NOTA. Sostenere il gruppo differenziale con una leva.

D Die Schrauben (14) abnehmen und den mittleren Deckel (13) entfernen.
BEMERKUNG. Das Differentialaggregat mit einem Hebel stützen.

ESP Remover los tornillos (14) y remover la tapa intermedia (13).
NOTA. Sostener el grupo diferencial con una palanca.

F Enlever les vis (14) puis enlever le couvercle intermédiaire (13).
NOTE. Soutenir le groupe différentiel à l'aide d'un levier.

ITA Scollegare dal pistone (6) la forcella (5) e, tenendola sollevata, rimuovere il gruppo differenziale (15).

D Vom Kolben (6) die Gabel (5) abtrennen. Die anheben und des Differentialaggregat (15) entfernen.

ESP Desconectar del pistón (6) la horquilla y, teniendola levantada, remover el grupo diferencial (15).

F Débrancher du piston (6) la fourchette (5) et en tenant cette dernière soulevée, enlever le groupe différentiel (15).

ITA Estrarre la forcella (5).

D Die Gabel (5) heraus nehmen.

ESP Extraer la horquilla (5).

F Extraire la fourchette (5).

ITA Rimuovere l'anello elastico (12) ed il pistone completo (6).

D Den Kolbenring (12) und den vollständigen Kolben (6) abnehmen.

ESP Remover el segmento elastico (12) y el pistón completo (6).

F Enlever l'anneau à ressort (12) et le piston complet (6).

ITA Asportare l'anello di guida (11) e la guarnizione OR (10).
NOTA. L'anello di guida (11) e la guarnizione (10) devono essere sostituiti ad ogni smontaggio.

D Den Führungsring (11) und den O-Ring (10) abnehmen.
BEMERKUNG. Der Führungsring (11) und die Dichtung (10) müssen jedesmal ausgewechselt werden, wenn sie abmontiert werden.

ESP Sacar el segmento de guía (11) y la guarnición OR (10).
NOTA. El segmento de guía (11) y la guarnición (10) deben de ser substituidos a cada desmontaje.

F Enlever la bague de guidage (11) et la garniture OR (10).
NOTE. La bague de guidage (11) et la garniture (10) doivent être substituées à chaque démontage.

ITA Rimuovere l'anello elastico (9) e scomporre il gruppo pistone (6) in tutti i suoi componenti (7), (8).

D Den Kolbenring (9) abnehmen und das Kolbenaggregat (6) auseinander nehmen, um die Teile (7) und (8) frei zu setzen.

ESP Remover el segmento elastico (9) y descomponer el grupo pistón (6) en todos sus componentes (7) y (8).

F Enlever l'anneau à ressort (9) et désassembler le groupe piston (6) de tous ses composants (7), (8).



- a**
- ITA** Rimuovere le viti (7), (8) di ritegno del coperchio (9) e le relative rondelle (10).
- D** Befestigungsschrauben (7) und (8) des Deckels (9) mit den Unterlegscheiben (10) abschrauben.
- ESP** Remover los tornillos (7), (8) de retencion de la tapa (9) y las relativas arandelas (10).
- F** Enlever les vis (7), (8) de fixation du couvercle (9) et ses relatives rondelles (10).

- c**
- ITA** Inserire due leve nelle cave predisposte ed allontanare il coperchio (9) dal corpo riduttore (11).
- D** Zwei Hebel in die Nuten stecken und den Deckel (9) vom Reduziererkörper (11) abheben.
- ESP** Introducir dos palancas en los orificios propuestas un empuje y alejar la tapa (9) del cuerpo reductor (11).
- F** introduire deux leviers dans les creux prédisposés et éloigner le couvercle (9) du corps réducteur (11).

- e**
- ITA** Asportare il coperchio (9) e rimuovere ogni traccia di sigillante.
- D** Deckel (9) abnehmen und Dichtungsmaße vollständig entfernen.
- ESP** Introducir la tapa (9) y remover cada mancha de cola.
- F** Enlever le couvercle (9) et nettoyer toute trace de colle.

- b**
- ITA** Inserire alternativamente nelle cave predisposte uno spintore e, con leggeri colpi di martello, separare il coperchio (9) dal corpo riduttore (11).
- D** Abwechselnd, in die Nuten einen Stößel stecken und diesen mit einem Hammer leicht schlagen, bis sich der Deckel (9) vom Reduziererkörper (11) löst.
- ESP** Introducir alternativamente en los orificios propuestas un empuje y, con ligeros golpes de martillo, separar la tapa (9) del cuerpo reductor (11).
- F** Introduire alternativement dans les creux prédisposés un poussoir et, à l'aide de légers coups de maillet, séparer le couvercle (9) du corps réducteur (11).

- d**
- ITA** Battere leggeri colpi con un mazzuolo per disimpegnare il coperchio (9) dall'ingranaggio superiore (12).
- D** Mit leichten Hammerschlägen, den Deckel (9) vom oberen Zahnrad (12) trennen.
- ESP** Golpear con ligeros golpes con un martillo para desconectar la tapa (9) del engranaje superior (12).
- F** Donner de légers coups de maillet pour dégager le couvercle (9) de l'engrenage supérieur (12).

- f**
- ITA** Asportare l'ingranaggio inferiore (13).
- D** Das untere Zahnrad (13) entfernen.
- ESP** Sacar el engranaje inferior (13).
- F** Enlever l'engrenage inférieur (13).



ITA Rimontare il gruppo differenziale (18) ed il coperchio intermedio (17).
ATTENZIONE! Se è stata sostituita la corona, ristabilire i giochi.
Per i dettagli, vedere «ASSEMBLAGGIO ED INSTALLAZIONE GRUPPO DIFFERENZIALE».

D Das Differentialaggregat (18) und den mittleren Deckel (17) wieder montieren.

ACHTUNG! Falls der Kranz ausgewechselt worden ist, Spiele wieder herstellen.
Weitere Einzelheiten im Paragraph «ZUSAMMENBAU UND INSTALLATION DES DIFFERENTIALAGGREGATS».

ESP Remontar el grupo diferencial (18) y la tapa intermedia (17).
CUIDADO! Si ha sido cambiada la corona, restabilizar los juegos.
Para los detalles, vease «ASEMBLAJE Y INSTALACION GRUPO DIFERENCIAL».

F Remonter le groupe différentiel (18) et le couvercle intermédiaire (17).

ATTENTION! Si la couronne a été substituée, rétablir les jeux.
Pour tout détail, voir «ASSEMBLAGE ET INSTALLATION GROUPE DIFFERENTIEL».

ITA Montare sul pignone (20) l'ingranaggio inferiore (13).

D Das untere Zahnrad (13) auf das Rad (20) montieren.

ESP Montar sobre el pinon (20) el engranaje inferior (13).

F Monter sur le pignon (20) l'engrenage inférieur (13).

ITA Spalmare la superficie di chiusura del corpo riduttore (11) con Loctite 510.
Lubrificare gli anelli di tenuta (6) e (15); montare il coperchio (9) assestandolo (se necessario) con leggeri colpi di un mazzuolo in materiale plastico.

D Die Schließfläche des Reduziererkörpers (11) mit Loctite 510 schmieren.
Kolbenringe (6) und (15) schmieren; Deckel (9) montieren und wenn nötig, mit einem Gummihammer leicht schlagen.

ESP Pasar la superficie de cierre del cuerpo reductor (11) con Loctite 510.
Lubrificar los segmentos de compresion (6) y (15); montar la tapa (9) arreglando (si necesario) con ligeros golpes de martillo en material plastico.

F Enduire la surface de fermeture du corps réducteur (11) avec du Loctite 510.

ITA Rimontare il braccio completo, controllando la planarità e bloccandolo con le modalità indicate nel paragrafo «ASSEMBLAGGIO DEI GRUPPI DI FRENATURA».
Collegare anche la barra di sterzata.

D Den gesamten Arm wieder montieren und Ebenheit laut Anweisungen des Paragraphs «ZUSAMMENBAU DER BREMSAGGREGATE» kontrollieren.
Lenkstange ebenfalls anschließen.

ESP Remontar el brazo completo, controlando la planaridad y bloqueando con las modalidades indicadas en el capítulo «ASEMBLAJE DE LOS GRUPOS DE FRENADURA».
Conectar también la barra de dirección.

F Remonter le bras complet, en contrôler l'uniformité et le bloquer suivant le mode indiqué au paragraphe «ASSEMBLAGE DES GROUPE DE FREINAGE».
Brancher également la barre de braquage.

ITA Inserire nel corpo riduttore (11) il gruppo ingranaggio superiore (12).

D Das obere Zahnradaggregat (12) in den Reduziererkörper (11) einsetzen.

ESP Introducir en el cuerpo reductor (11) el grupo engranaje superior (12).

F Introduire dans le corps réducteur (11) le groupe engrenage supérieur (12).

ITA Bloccare il coperchio (9) con le viti (7) e (8) e le relative rondelle (10) serrando con il metodo di serraggio incrociato.
Coppia di serraggio: 82÷91 Nm

D Deckel (9) mit den Schrauben (7) und (8) und den Unterlegscheiben (10) festschrauben; die Schrauben im Kreuz abwechselnd fest ziehen.
Anzugsmoment: 82÷91 Nm.

ESP Bloquear la tapa (9) con los tornillos (7) y (8) y las relativas arandelas (10) apretando con el metodo de torsion cruzado.
Par de torsion : 82÷91 Nm.

F Bloquer le couvercle (9) avec les vis (7) et (8) et leurs relatives rondelles (10) en serrant à l'aide du système de serrage croisé.
Couple de serrage: 82÷91 Nm.

TABLE OF CONTENTS

T12000 TRANSMISSION ASSEMBLY

HOW THE UNITS OPERATE

SECTIONAL VIEWS AND PARTS IDENTIFICATION

Transmission Case and Plate Group	Fig. A
Converter Group	Fig. B
Forward - Reverse and 1st - 2nd Clutch Group	Fig. C
High - 3rd and Output Shaft Group	Fig. D
3rd and Output Shaft Group with Disconnect	Fig. E
Control Valve Group—Dual Modulation	Fig. F
Control Valve Group—Single Modulation, Mechanical Inching	Fig. G
Assembly Instruction	Fig. H, I, J, K, L, M
DISASSEMBLY OF TRANSMISSION	1
REASSEMBLY OF TRANSMISSION	65
CLUTCH ENGAGEMENT (POWER FLOW) 4 AND 6 SPEED	90
CLUTCH ENGAGEMENT (POWER FLOW) 3 SPEED	91
DRIVE PLATE INSTALLATION	92
TRANSMISSION TO ENGINE INSTALLATION PROCEDURE	93
SPECIFICATIONS AND SERVICE DATA	94
SERVICING MACHINE AFTER TRANSMISSION OVERHAUL	95
EXTERNAL PLUMBING AND PRESSURE CHECK POINTS	96, 97
CLEANING AND INSPECTION	98
PARKING BRAKE SERVICE	99
TROUBLESHOOTING GUIDE	100
CONVERTER STALL PROCEDURE	101
ELECTRIC SOLENOID CONTROL WIRING DIAGRAM	102, 103

NOTE: Metric Dimensions Shown in Brackets [].

T12000
HIGH — 3RD AND OUTPUT SHAFT GROUP

ITEM	DESCRIPTION	QUANTITY	ITEM	DESCRIPTION	QUANTITY
1	Sleeve Locating Screw	1	40	End Plate Snap Ring	1
2	Oil Distributor Sleeve	1	41	Clutch Gear Thrust Washer	1
3	Piston Ring	2	42	Clutch Gear Thrust Washer Bearing	1
4	Bearing and Seal Assembly	1	43	Clutch Gear Thrust Washer	1
5	1st Drive Gear	1	44	Thrust Washer Retaining Snap Ring	1
6	Gear Hub Snap Ring	1	45	3rd Clutch Gear Bearing	1
7*	Gear Hub Snap Ring	1	46	3rd Gear and Shaft	1
8*	Clutch Gear Thrust Washer	1	47	Rear Bearing	1
9*	Clutch Gear Thrust Washer Bearing	1	48	Rear Bearing Retaining Snap Ring	1
10*	Clutch Gear Thrust Washer	1	49	Output Shaft Bearing Snap Ring	1
11*	Bearing	1	50	Output Shaft Bearing	1
12*	Bearing Spacer	1	51	Output Shaft Bearing Retaining Snap Ring	1
13*	Bearing	1	52	Plug—Capped End	1
14*	4th Clutch Gear	1	53	Oil Seal Sleeve “O” Ring	1
15*	Clutch Gear Thrust Washer	1	54	Output Shaft Bearing Snap Ring	1
16*	Clutch Gear Thrust Washer Bearing	1	55	Output Shaft and Brake Flange	1
17*	Clutch Gear Thrust Washer	1	56	Output Shaft Bearing Snap Ring	1
18*	End Plate Snap Ring	1	57	Output Shaft Sleeve “O” Ring	1
19*	End Plate	1	58	Output Shaft Oil Seal	1
20*	Inner Disc	6	59	Oil Seal Sleeve	1
21*	Outer Disc	6	60	Output Shaft Bearing	1
22*	Retainer Snap Ring	1	61	Output Shaft Bearing Snap Ring	1
23*	Snap Ring Retainer	1	62	Output Shaft Gear	1
24*	Disc Spring	5	63	Gear Retaining Ring	1
25*	Clutch Piston Wear Plate	1	64	Flange Retaining Ring	1
26*	Clutch Piston and Ball Seat Assembly	1	65	Output Shaft Bearing Snap Ring	1
27*	Clutch Piston Outer Seal	1	66	Output Shaft Bearing	1
28*	Clutch Piston Inner Seal	1	67	Oil Seal Sleeve	1
29	Clutch, Drum, Shaft, and Plug Assembly (4 and 6 Speed Clutch Drum Shown)	1	68	Output Shaft Oil Seal	1
30	Clutch Piston Inner Seal	1	69	Flange Plug	1
31	Clutch Piston Outer Seal	1	70	Output Flange	1
32	Clutch Piston and Ball Seat Assembly	1	71	Output Shaft Bearing Snap Ring	1
33	Clutch Piston Wear Plate	1	72	Oil Seal Sleeve “O” Ring	1
34	Disc Spring	5	73	Caliper Assembly Capscrew Locking Nut ..	2
35	Snap Ring Retainer	1	74	Caliper Brake Assembly	1
36	Retainer Snap Ring	1	75	Caliper Assembly Mounting Capscrew	2
37	Outer Disc	5	76	Brake Disc	1
38	Inner Disc	5	77	Brake Disc Capscrew Lockwasher	4
39	End Plate	1	78	Brake Disc Capscrew	4

* Used in 4 and 6 speed only.

See Figure E for 3rd and output shaft with disconnect.

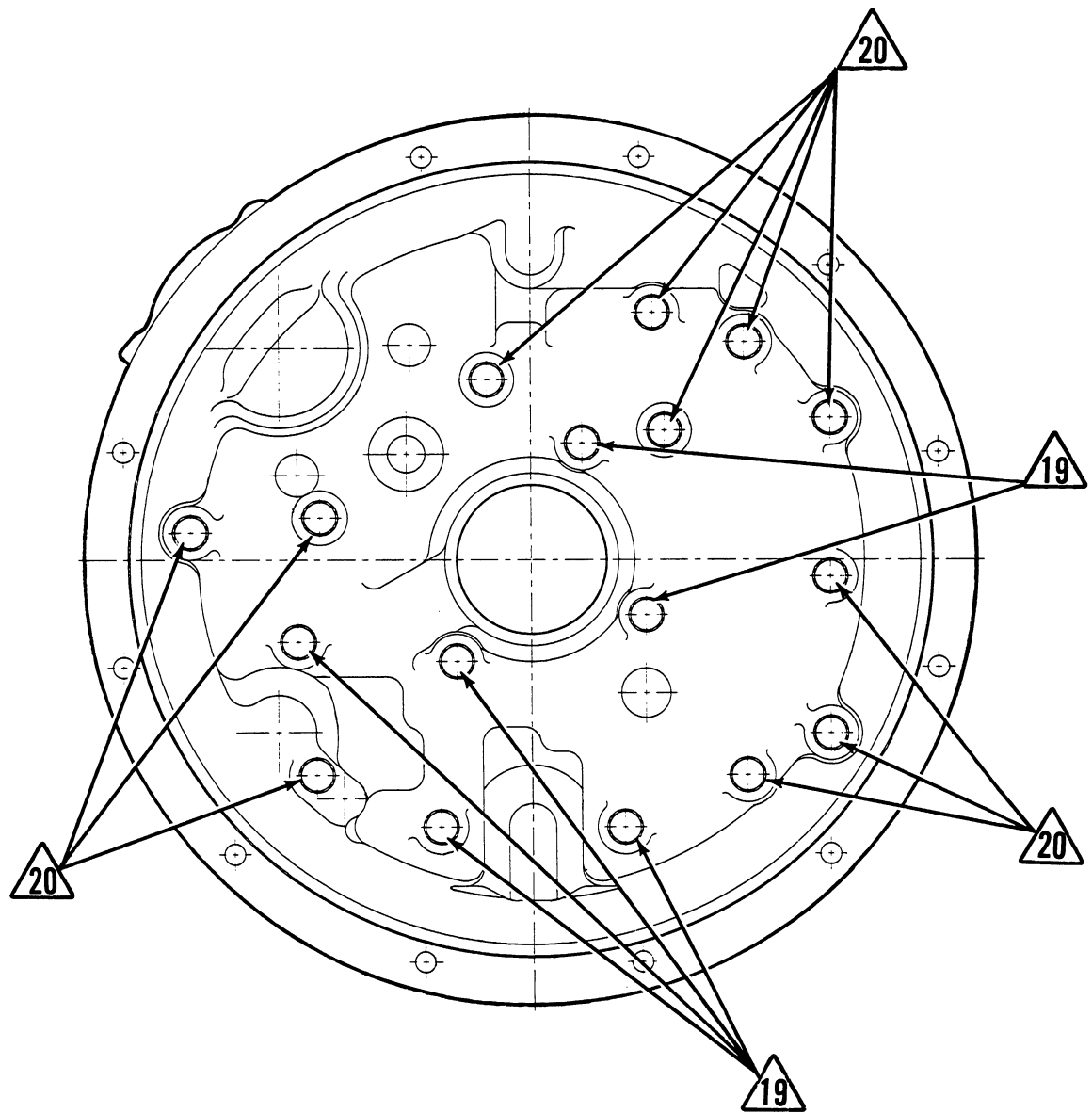

TORQUE SPECIFICATION FOR LUBRICATED OR PLATED SCREWS AND NUTS				
NOMINAL SIZE	GRADE 8.8 or 9.8		GRADE 10.9	
	COARSE THREAD		COARSE THREAD	
	lb·ft	[N·m]	lb·ft	[N·m]
M10	30-37	[40-50]	44-48	[60-65]
M12	50-55	[65-75]	74-81	[100-110]

PIPE PLUG TORQUE CHART				
THREAD NPTF	TORQUE			
	lb·ft	[N·m]		
1/16-27	5-7	[7-9]		
1/8-27	7-10	[9-14]		
1/4-18	15-20	[20-27]		
3/8-18	25-30	[34-41]		
1/2-14	30-35	[41-47]		
3/4-10	40-45	[54-61]		

PERMANENT PLUG METRIC				
THREAD SIZE	TORQUE			
	lb·ft	[N·m]		
M18 x 1.5 6H	25-30	[34-41]		
M26 x 1.5 6H	45-50	[61-68]		

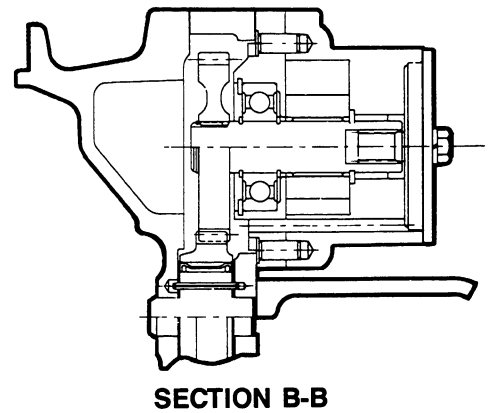

Figure K

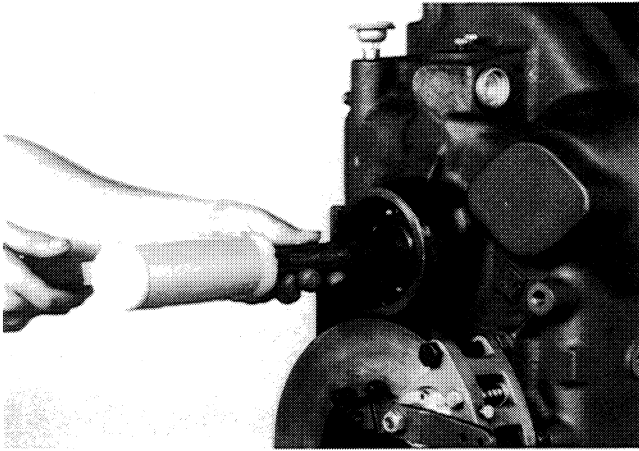

Figure 32
Tap 3rd clutch gear and hub from bearing.

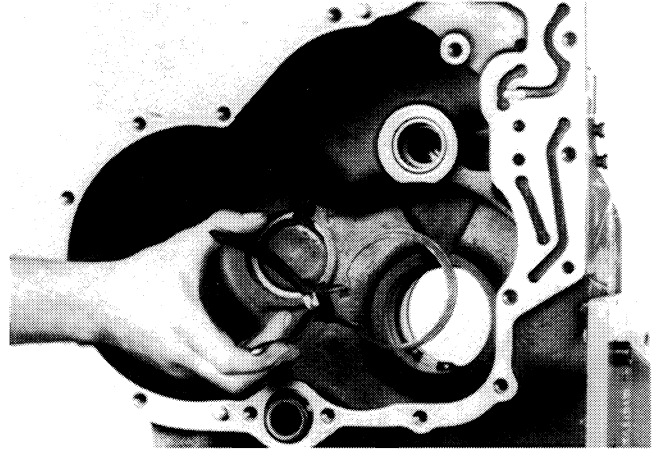

Figure 35
Remove inner bearing locating ring.

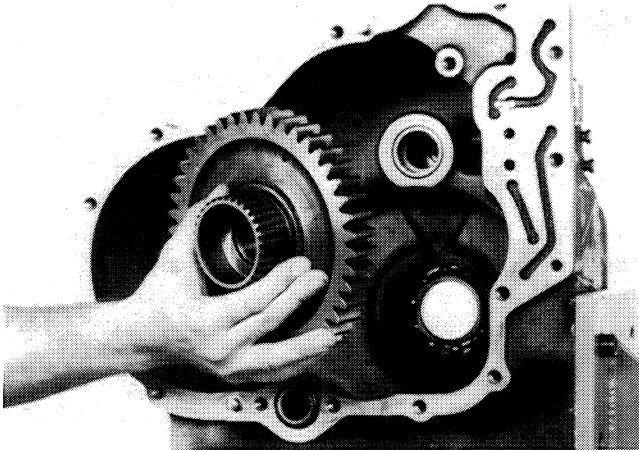

Figure 33
Remove gear and hub.

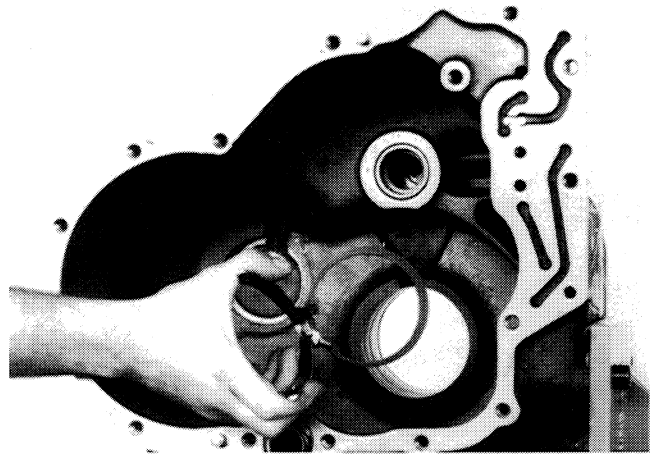

Figure 36
Remove outer bearing locating ring.

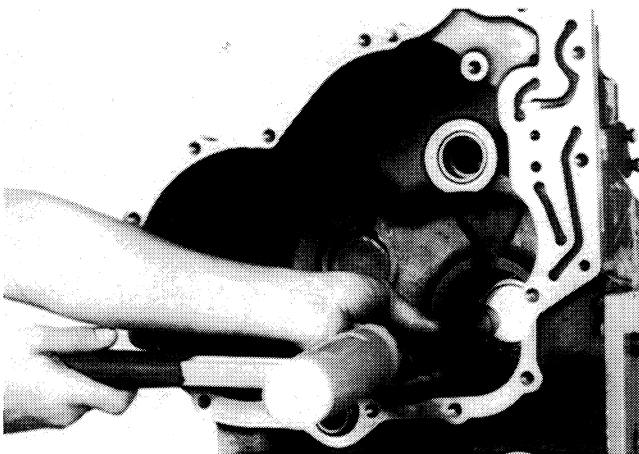

Figure 34
Tap 3rd clutch rear bearing from housing.

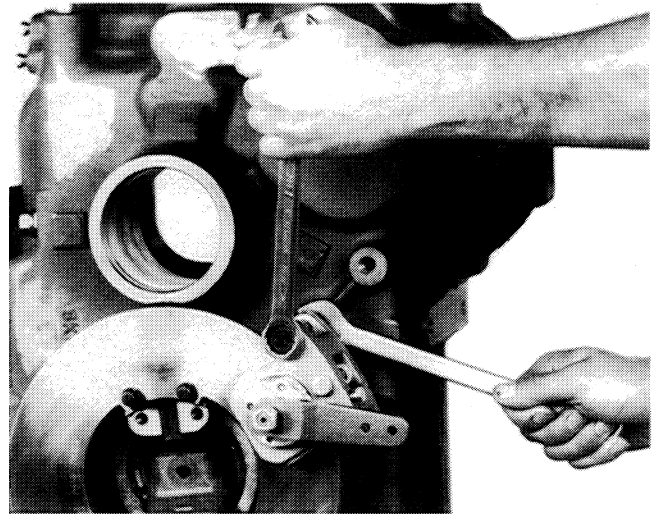

Figure 37
Remove brake disc assembly bolts from brake and housing. **NOTE:** Brake is an option and will not be on all units.

REASSEMBLY OF LOW (1ST) CLUTCH (See cleaning and inspection page)

Two bleed valves in clutch drum must be clean and free of any foreign material.

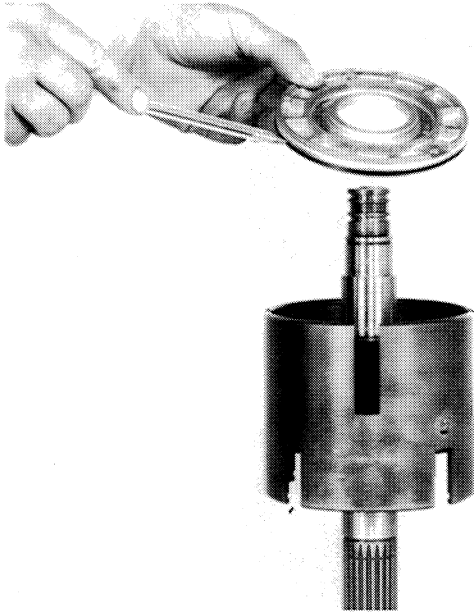

Figure 92

Install clutch piston outer seal ring.

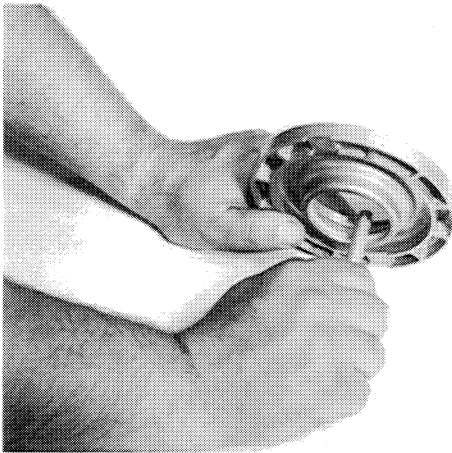

Figure 93

Install clutch piston inner seal ring. **NOTE:** Ring must be sized before installing in clutch drum. Sizing is best accomplished by rotating piston while holding a round object against the new seal ring as shown. Rotate piston until seal ring is flush with outer diameter of piston.

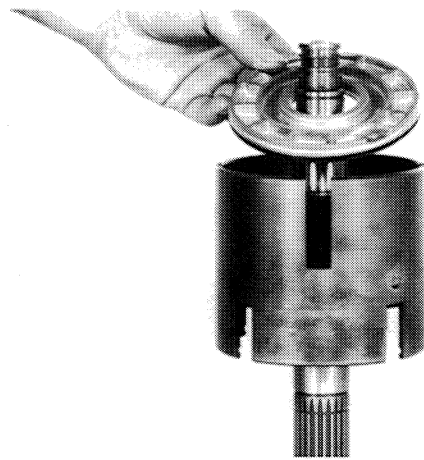

Figure 94

Position piston in low clutch drum as shown. Use caution as not to damage inner and outer piston sealing rings.

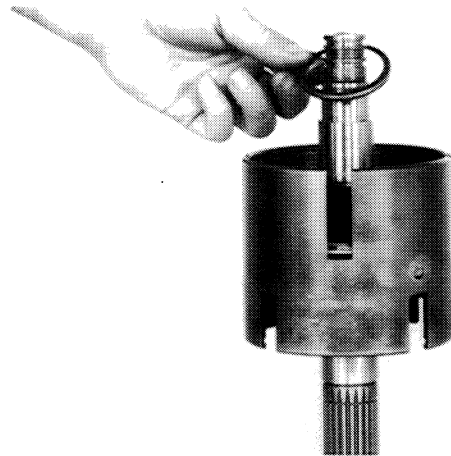

Figure 95

Position clutch piston wear plate on piston.

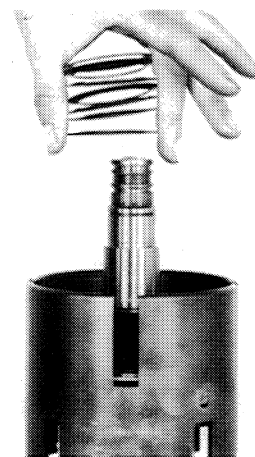

Figure 96

Install piston return disc springs. First spring with large diameter of bevel toward wear plate. Alternate seven (7) springs. **Note:** See page 104.

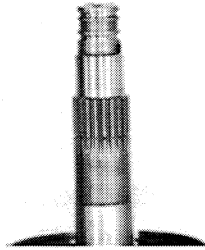
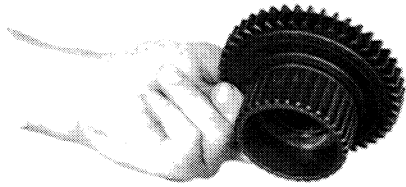

Figure 144

Remove clutch gear and disc hub.



Figure 147

Remove end plate retainer ring.

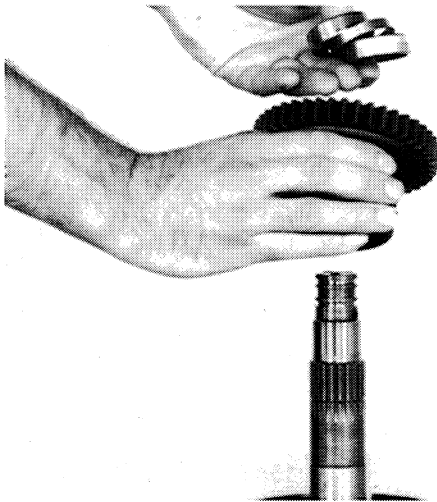

Figure 145

Remove bearings and spacer from clutch gear.

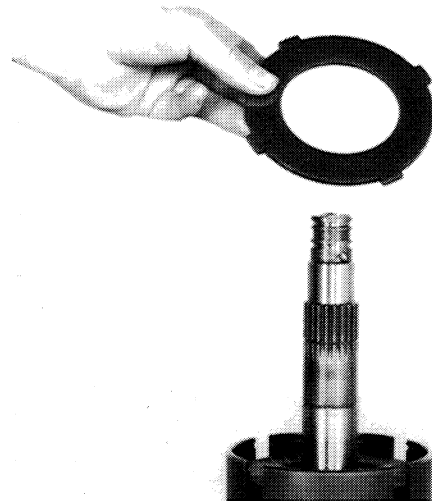

Figure 148

Remove end plate.



Figure 146

Remove outer thrust washer, thrust bearing, and inner thrust washer.

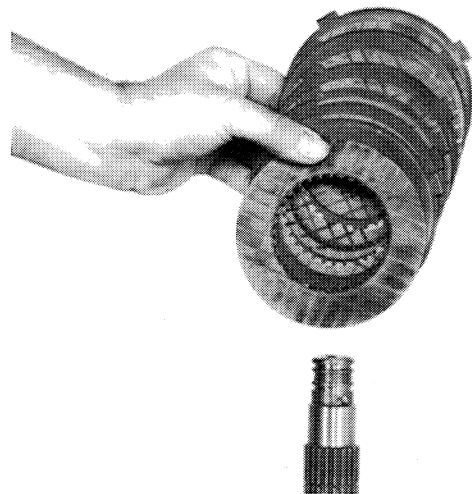

Figure 149

Remove clutch discs.

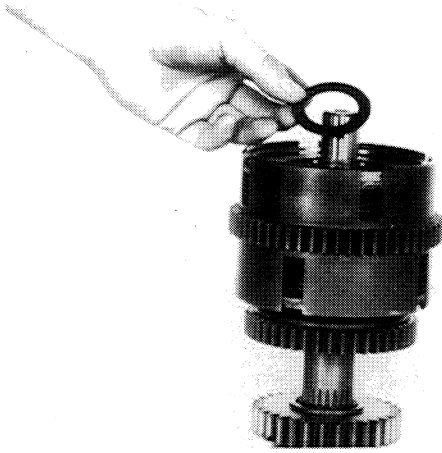

Figure 198

Position thrust bearing inner washer on clutch shaft.

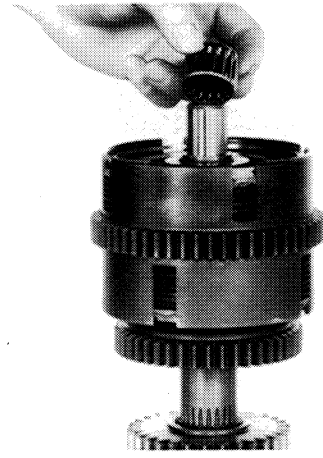

Figure 201

Install 3rd clutch pilot bearing on clutch shaft. A coat of high quality grease will hold pilot bearing in position.



Figure 199

Position thrust bearing on clutch shaft against inner thrust bearing washer.

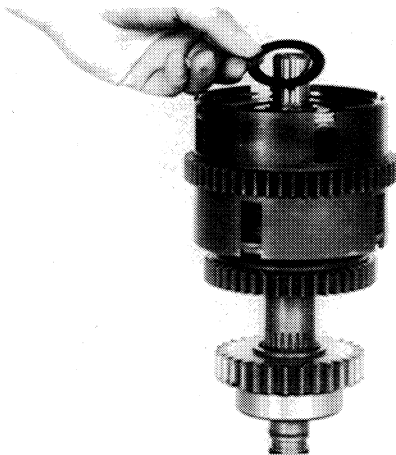

Figure 200

Install outer thrust bearing washer against thrust bearing. Install thrust washer retainer ring.

DISASSEMBLY AND REASSEMBLY OF FORWARD AND REVERSE CLUTCHES

NOTE: A 3 speed transmission will not have external gear teeth on the forward and reverse clutch drum.

REVERSE CLUTCH BEING DISASSEMBLED

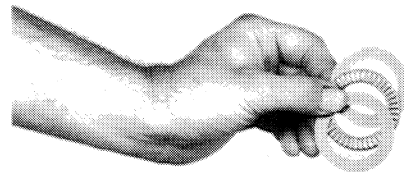

Figure 202

Remove outer thrust washer, thrust bearing, and inner thrust washer.

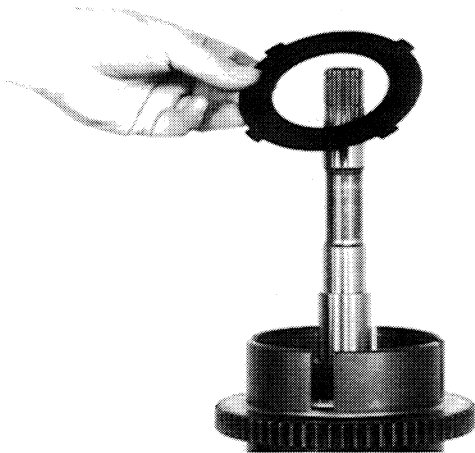

Figure 253

Install first steel (outer) clutch disc.

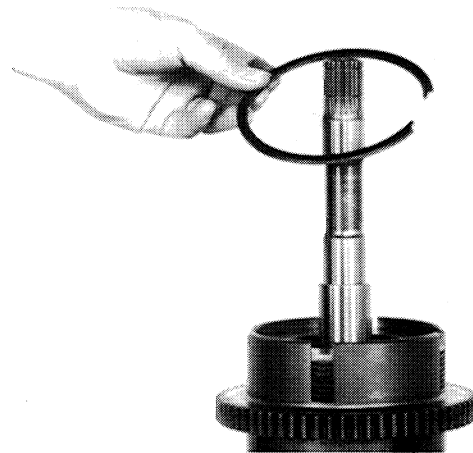

Figure 256

Install end plate retainer ring.

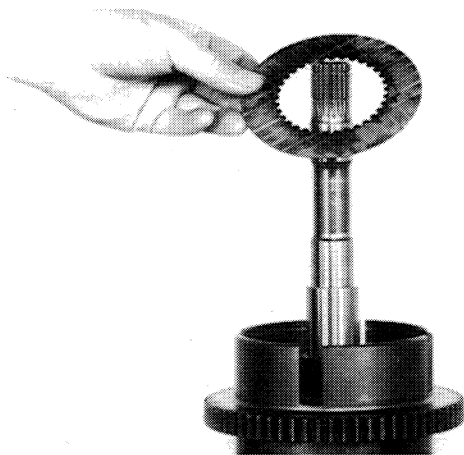

Figure 254

Install first friction (inner) clutch disc. Alternate steel and friction until six (6) steel and six (6) friction discs are in position.

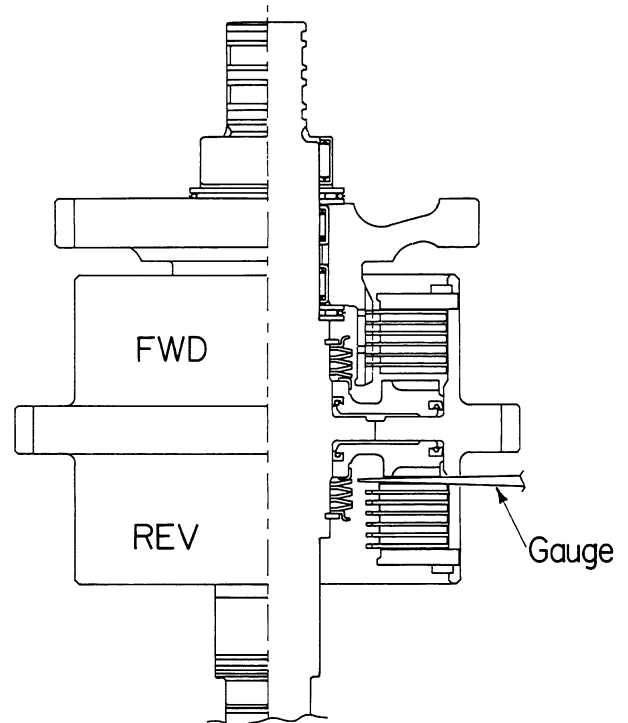

Figure 256a

NOTE: Reverse clutch pack must be checked for clutch disc clearance.

Stand the clutch assembly on end. The clutch disc on the bottom will fall to the end plate.

Measure the distance between the clutch piston and the first steel disc by inserting a feeler gauge or taper gauge through the slots in the clutch drum.

The required clearance is .048-.108 [1,22-2,74].

If the clearance is greater than .108 [2,74] add one steel disc under the end plate.



Figure 255

Install clutch disc end plate.

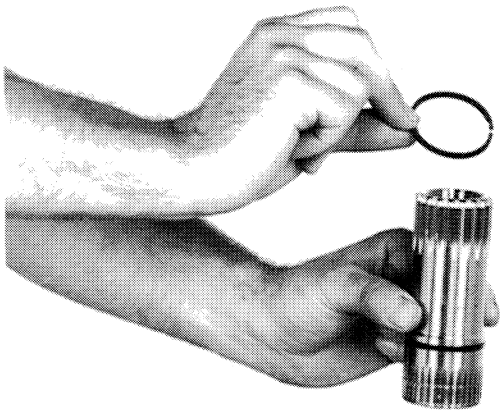

Figure 309

Install oil sealing ring on expander ring. **NOTE:** Expander spring gap to be 180 degrees from sealing ring hook joint.

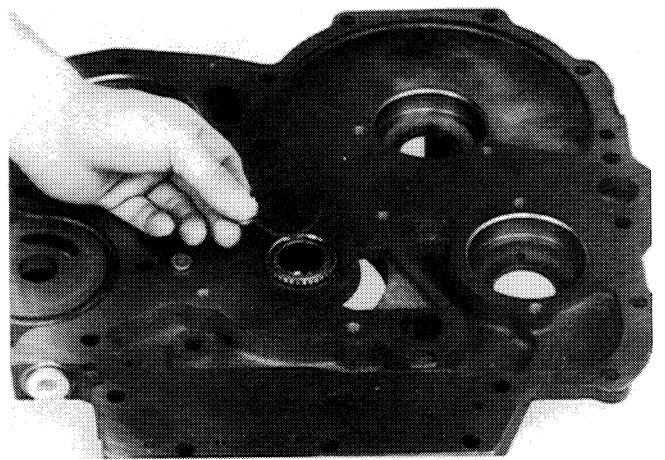

Figure 312

Install stator support locating ring.

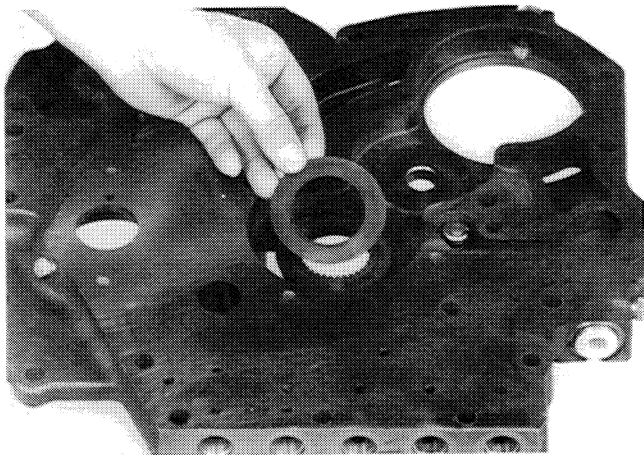

Figure 310

Position impeller hub gear washer on spacer plate.

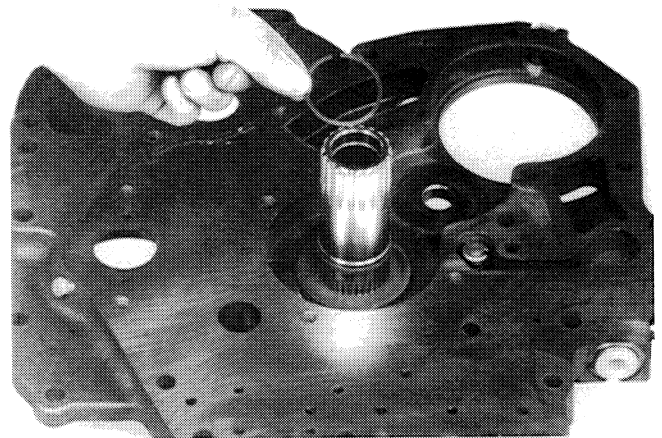

Figure 313

Push support back through spacer until locating ring shoulders in support bore. Turn spacer plate over and install support retaining ring.

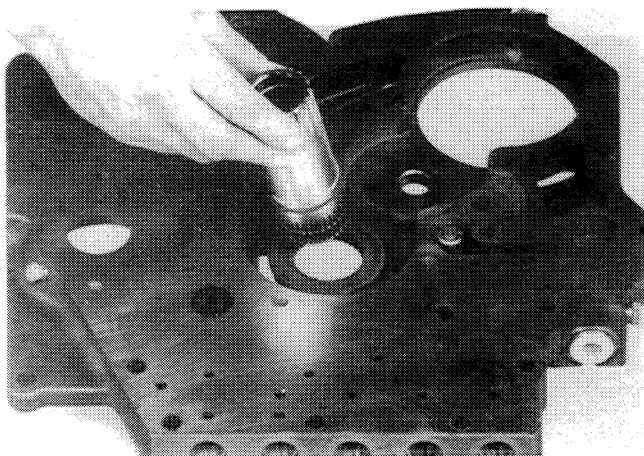

Figure 311

Install stator support through washer and spacer plate.

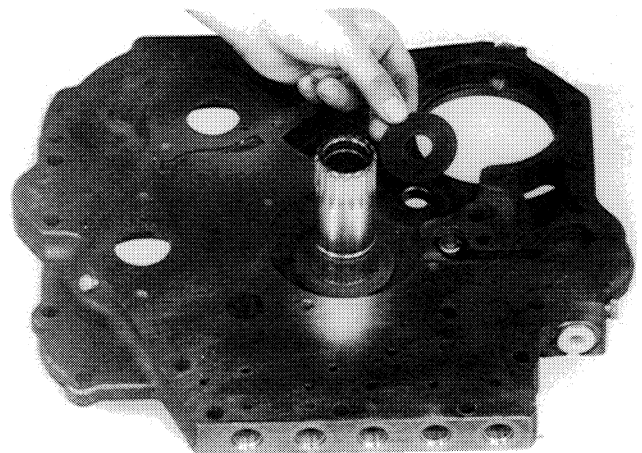

Figure 314

Position pump drive idler shaft washer on spacer plate.

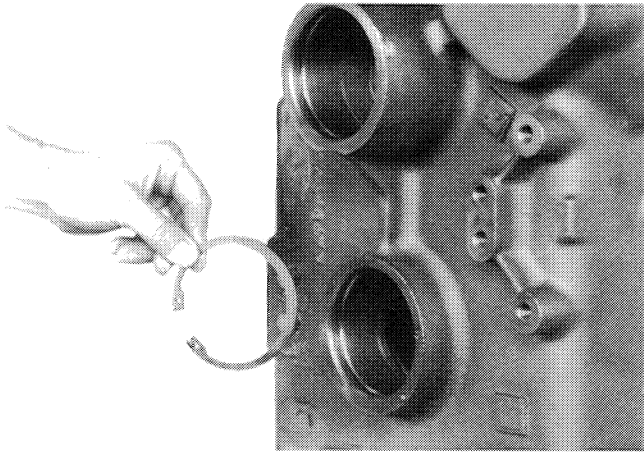

Figure 367

Install output shaft inner bearing locating ring in rear of transmission case.

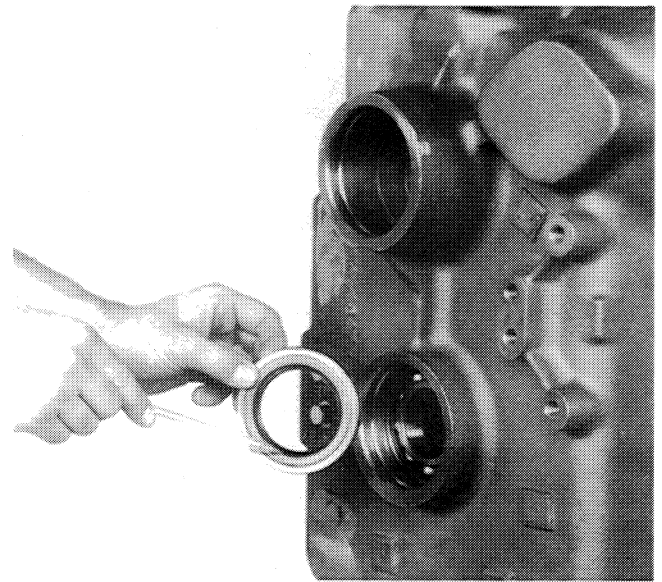

Figure 370

Apply a very light coat of Permatex #2 to the outer diameter of the output flange oil seal. Press oil seal in oil seal sleeve. Oil seal must be flush with one side of face of oil seal sleeve and lip of seal must be in.

Position oil seal sleeve in transmission case with recessed portion of oil seal toward output bearing. This leaves a space between oil seal and output bearing.

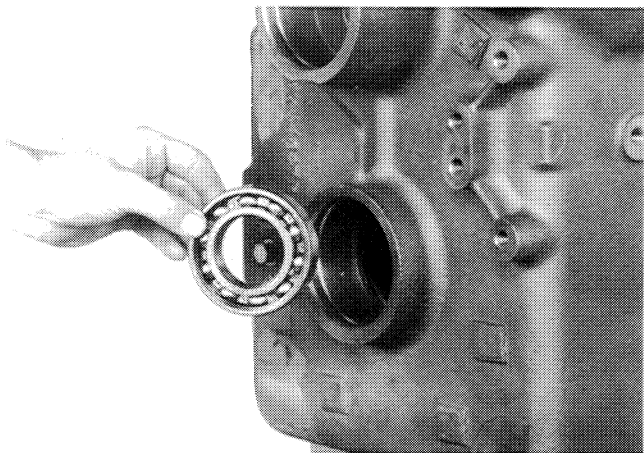

Figure 368

Install rear bearing in case against locating ring.

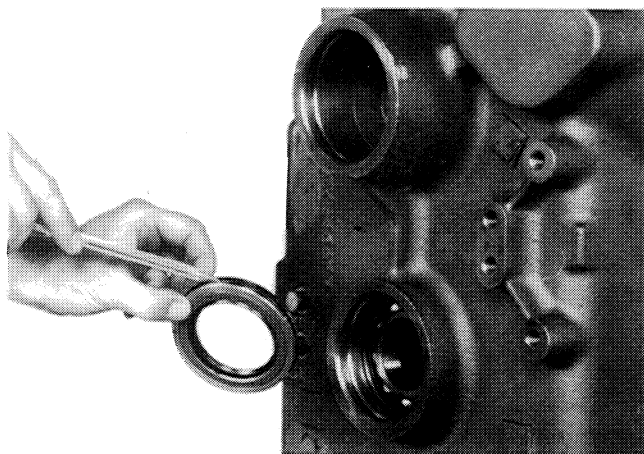

Figure 369

Install new "O" ring on rear oil seal sleeve.

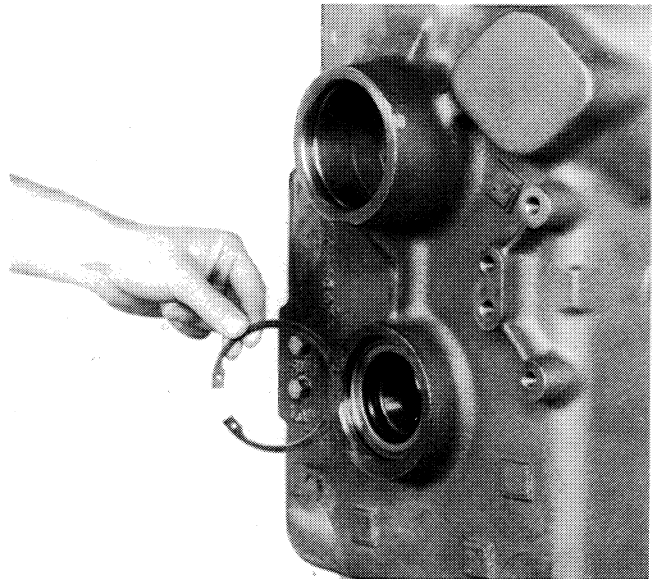

Figure 371

Install oil seal sleeve retainer ring.

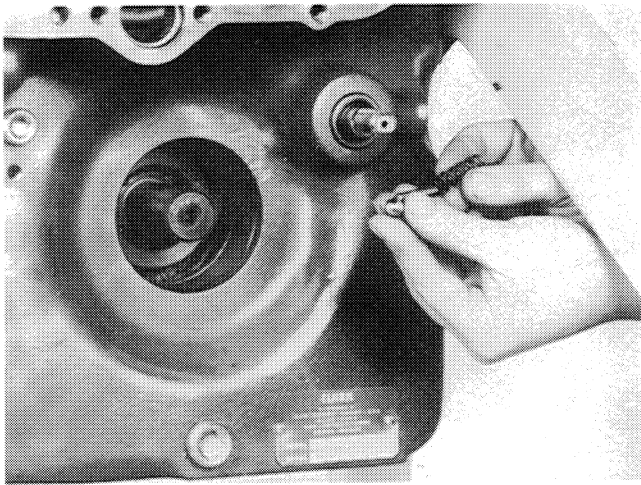

Figure 421
Remove detent spring, ball, and overshift stop pin.

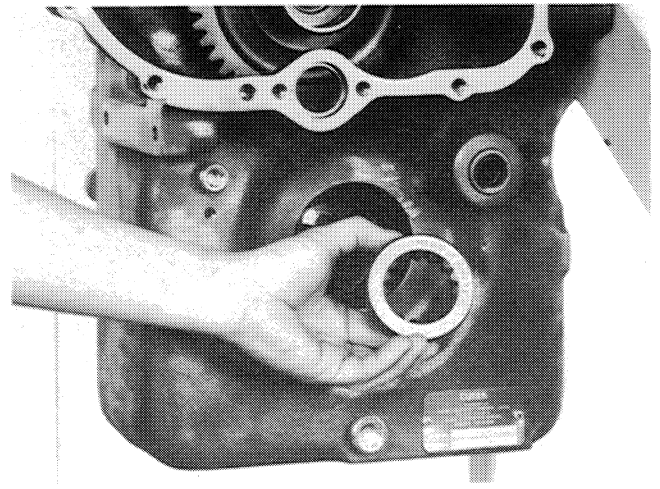

Figure 424
Remove disconnect shift hub.

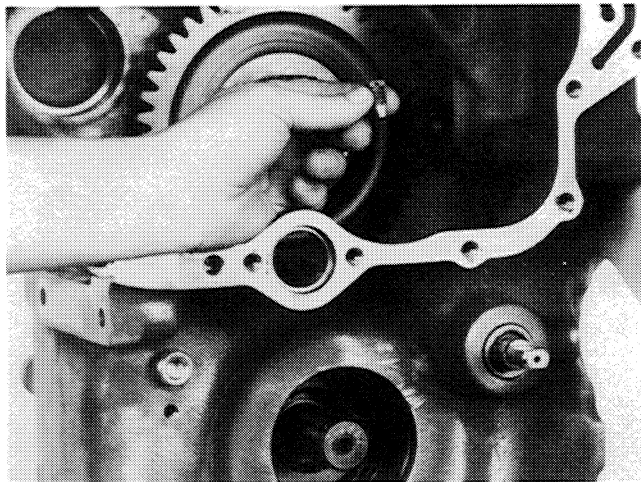

Figure 422
Remove shift fork to shift rail lock screw.

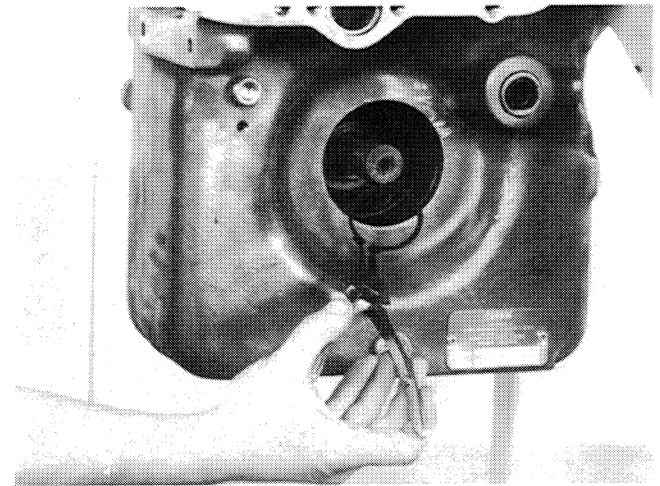

Figure 425
Remove output gear to shaft retainer ring.

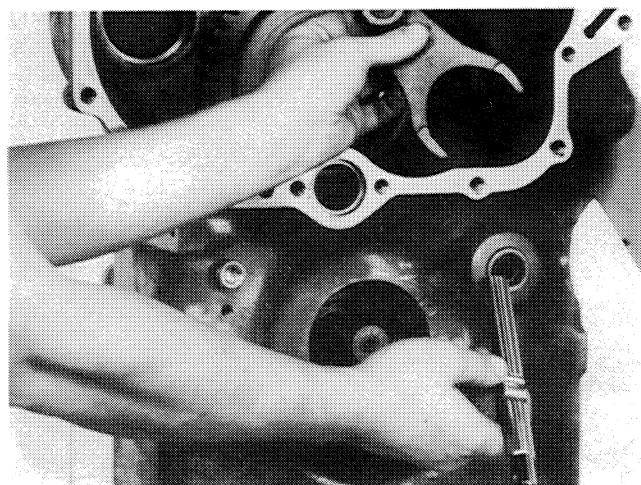

Figure 423
Remove disconnect shift fork and rail.

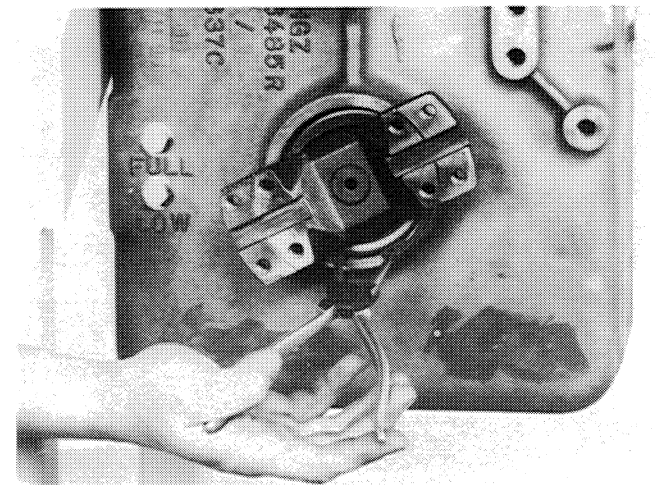

Figure 426
Remove rear output flange retainer ring from ring groove.

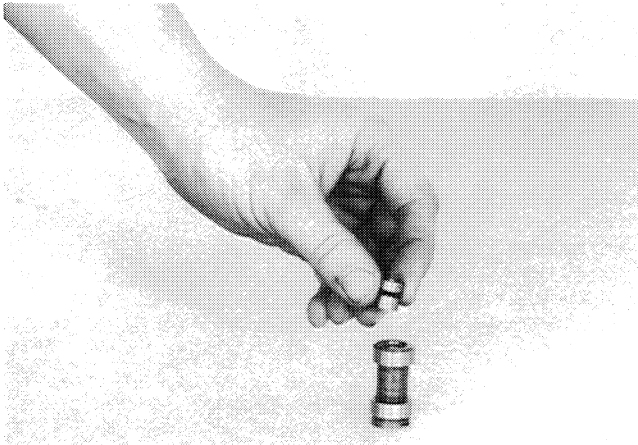

Figure 478

Position sleeve and ball assembly in regulator spool with check ball retainer pin up.



Figure 481

Install regulator spool stop, spring, and regulator spool and sleeve assembly in housing sleeve.

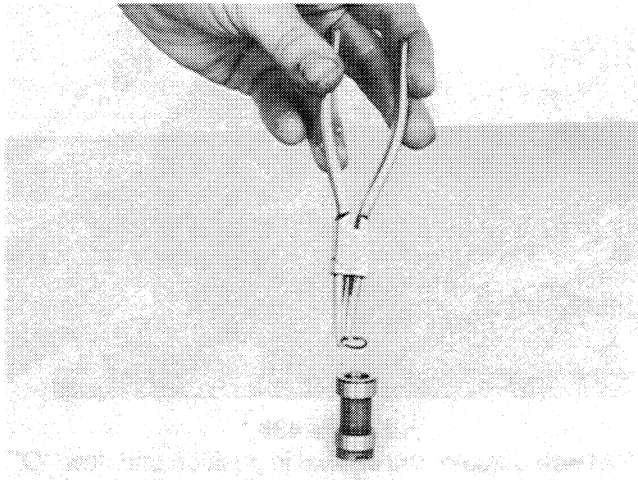

Figure 479

Install sleeve retainer ring.

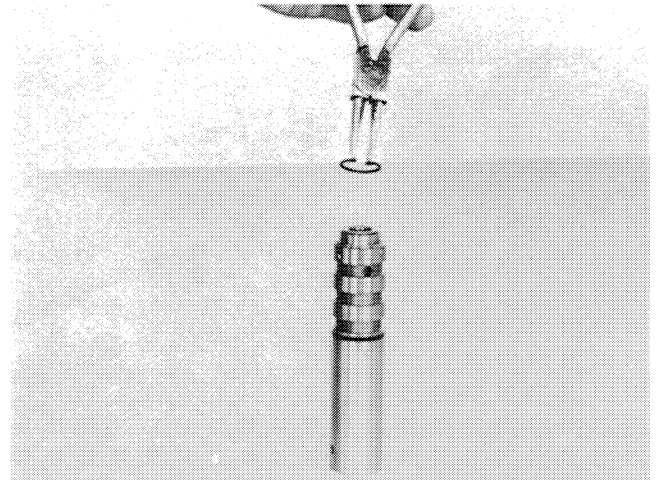

Figure 482

Compress regulator spool spring and install retainer ring.

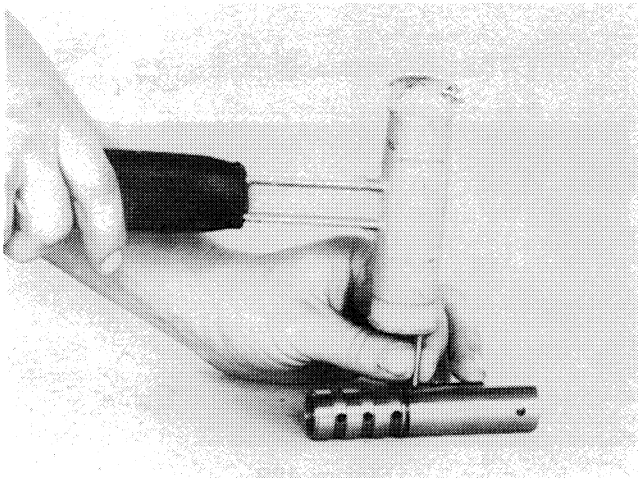

Figure 480

Install housing sleeve pin.

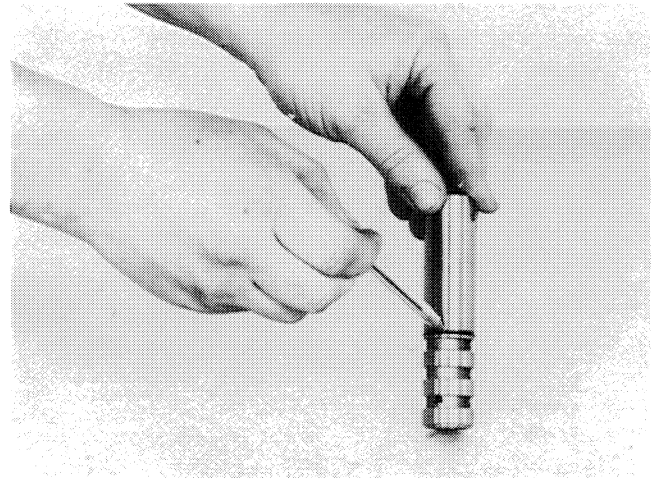

Figure 483

Position new "O" ring on modulation sleeve.

3, 4 & 6 Speed

PORT K (41)

CHECK PORT - CLUTCH
PRESSURE
3 SPEED: 1ST
4 SPEED: 1ST
6 SPEED: FWD 1ST, 2ND, REV 1ST.

PORT E (42)

CHECK PORT - CLUTCH
PRESSURE
3 SPEED: 2ND
4 SPEED: 2ND
6 SPEED: FWD 3RD, 4TH, REV 2ND.

PORT L

OIL FROM COOLER

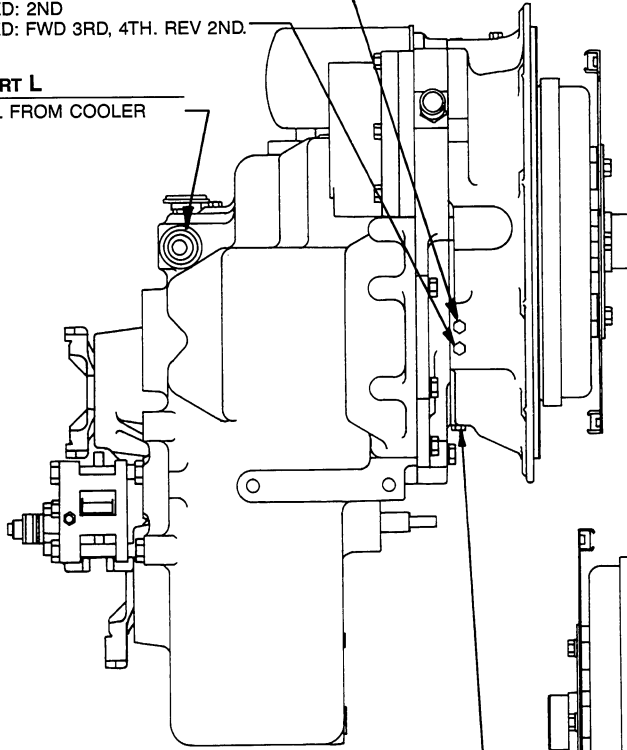

RIGHT SIDE VIEW

PORT F (43)

CHECK PORT - CLUTCH
PRESSURE
3 SPEED: 3RD
4 SPEED: 3RD
6 SPEED: FWD 5TH, 6TH, REV 3RD.

PORT G (44)

CHECK PORT - CLUTCH
PRESSURE
4 SPEED: FWD 4TH
6 SPEED: FWD HI

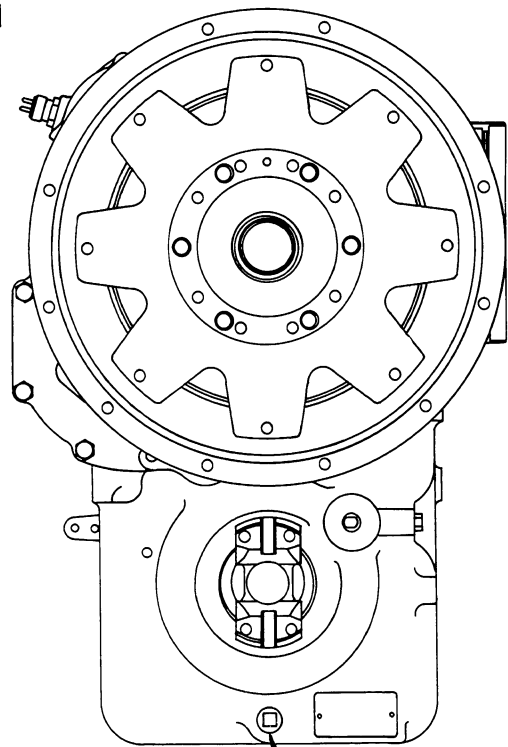

FRONT VIEW

PORT N

MAGNETIC DRAIN PLUG

PRESSURE CHECK PORT (31)
REGULATED CLUTCH PRESSURE

PORT M (45)

CHECK PORT - FORWARD
CLUTCH PRESSURE

PORT C (46)

CHECK PORT - REVERSE
CLUTCH PRESSURE

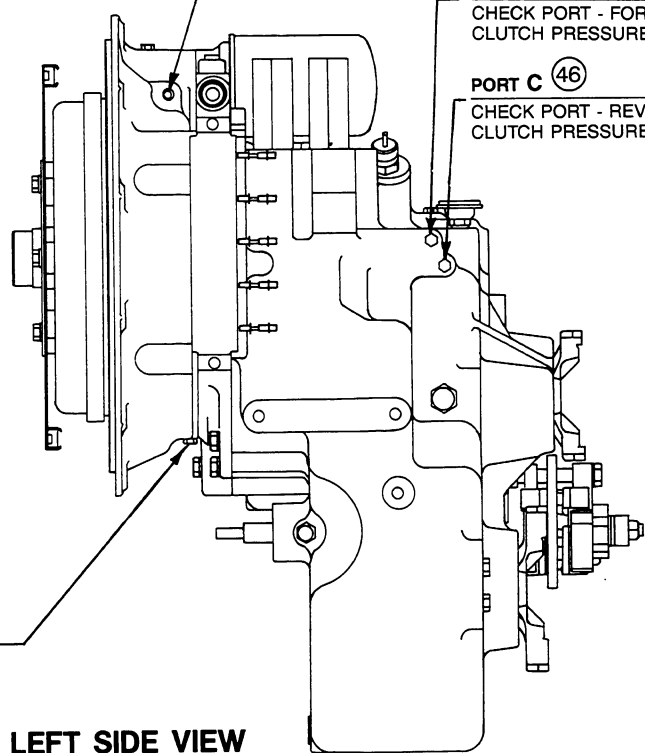

LEFT SIDE VIEW

See Pages 106 through 109 for Hydraulic Diagram.

CLICK HERE TO **DOWNLOAD** THE COMPLETE MANUAL

- Thank you very much for reading the preview of the manual.
- You can download the complete manual from: www.heydownloads.com by clicking the link below



- Please note: If there is no response to CLICKING the link, please download this PDF first and then click on it.

CLICK HERE TO **DOWNLOAD** THE COMPLETE MANUAL