



SERVICE MANUAL  
**WHEEL LOADER**  
**621E**  
**TIER 3**

84243974  
(Replaces 87634756)

Revised June 2009  
Issued September 2007

CLICK HERE TO **DOWNLOAD** THE COMPLETE MANUAL

- Thank you very much for reading the preview of the manual.
- You can download the complete manual from: [www.heydownloads.com](http://www.heydownloads.com) by clicking the link below





- Please note: If there is no response to **CLICKING** the link, please download this PDF first and then click on it.

CLICK HERE TO **DOWNLOAD** THE COMPLETE MANUAL

## TORQUE SPECIFICATIONS - DECIMAL HARDWARE

Use the torques in this chart when special torques are not given. These torques apply to fasteners with both UNC and UNF threads as received from suppliers dry, or when lubricated with engine oil. Not applicable if special graphities, Molydisulfide greases, or other extreme pressure lubricants are used.

Grade 5 Bolts, Nuts, and Studs		
		
Size	Pound-Inches	Newton metres
1/4 inch	108 to 132	12 to 15
5/16 inch	204 to 252	23 to 28
3/8 inch	420 to 504	48 to 57
Size	Pound-Feet	Newton metres
7/16 inch	54 to 64	73 to 87
1/2 inch	80 to 96	109 to 130
9/16 inch	110 to 132	149 to 179
5/8 inch	150 to 180	203 to 244
3/4 inch	270 to 324	366 to 439
7/8 inch	400 to 480	542 to 651
1.0 inch	580 to 696	787 to 944
1-1/8 inch	800 to 880	1085 to 1193
1-1/4 inch	1120 to 1240	1519 to 1681
1-3/8 inch	1460 to 1680	1980 to 2278
1-1/2 inch	1940 to 2200	2631 to 2983

Grade 8 Bolts, Nuts, and Studs		
		
Size	Pound-Inches	Newton metres
1/4 inch	144 to 180	16 to 20
5/16 inch	288 to 348	33 to 39
3/8 inch	540 to 648	61 to 73
Size	Pound-Feet	Newton metres
7/16 inch	70 to 84	95 to 114
1/2 inch	110 to 132	149 to 179
9/16 inch	160 to 192	217 to 260
5/8 inch	220 to 264	298 to 358
3/4 inch	380 to 456	515 to 618
7/8 inch	600 to 720	814 to 976
1.0 inch	900 to 1080	1220 to 1465
1-1/8 inch	1280 to 1440	1736 to 1953
1-1/4 inch	1820 to 2000	2468 to 2712
1-3/8 inch	2380 to 2720	3227 to 3688
1-1/2 inch	3160 to 3560	4285 to 4827

**NOTE:** Use thick nuts with Grade 8 bolts.

# MAINTENANCE POINTS

## Model 621E

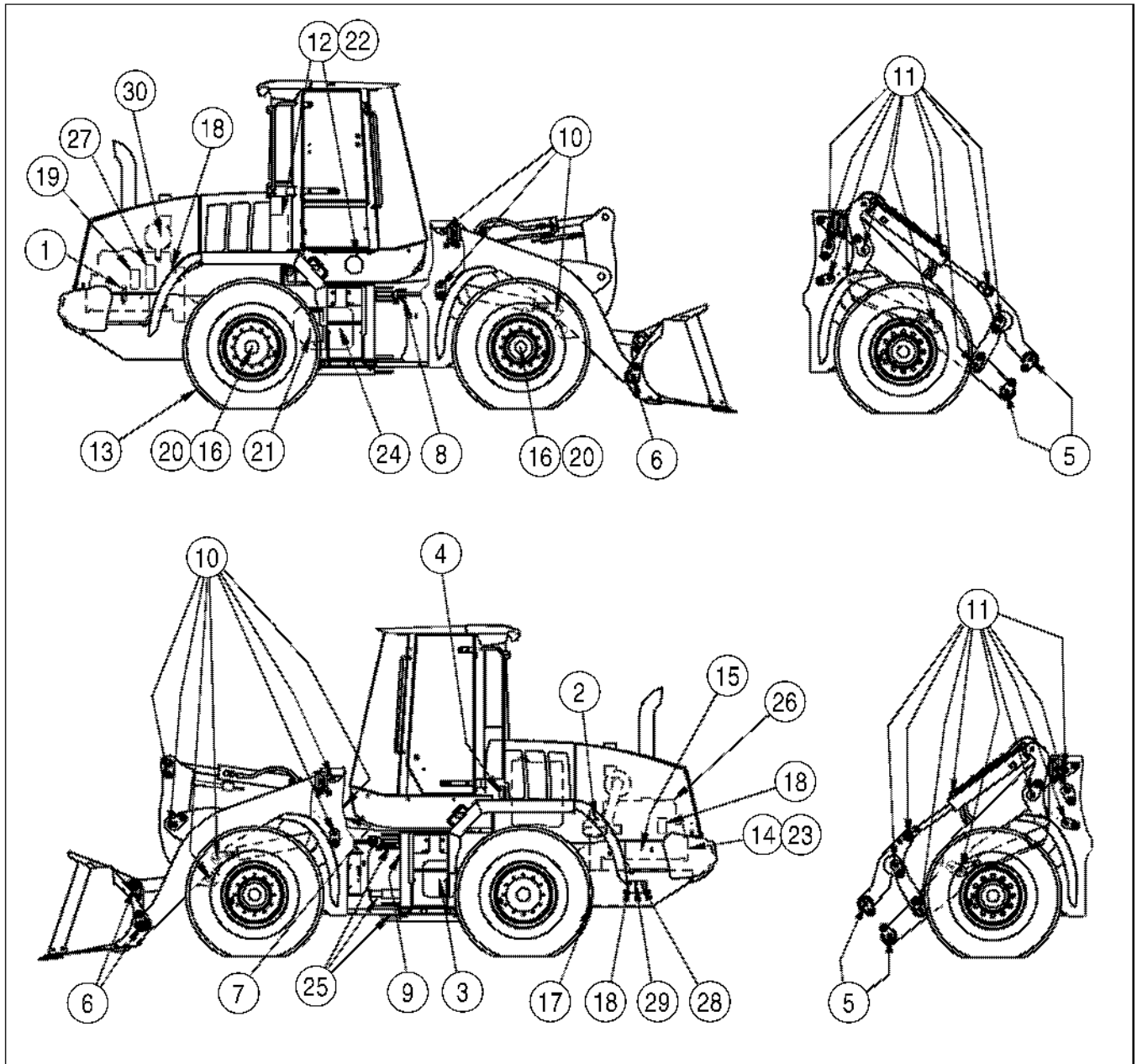

BS07D423

See your Operators manual for maintenance of safety related items and for detailed information of the service items on this chart. Operators and service manuals are available for this machine from your dealer.

If you operate the machine in severe conditions, lubricate and service the machine more frequently.

# ENGINE

## Removal

### STEP 1

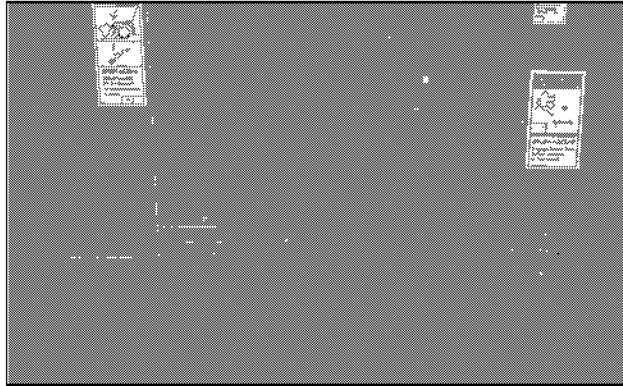

BD03A040

Park machine on a level surface and lower bucket to ground. Put articulation lock in LOCKED position.

### STEP 2

Stop engine. Actuate brake pedal several times to discharge brake accumulators. Put key switch in ON position and move loader control lever back and forth at least 30 times to release any pressure from hydraulic circuit. Put key switch in OFF position.

### STEP 3

Slowly loosen the filler cap for hydraulic reservoir to release air pressure in hydraulic reservoir.

### STEP 4

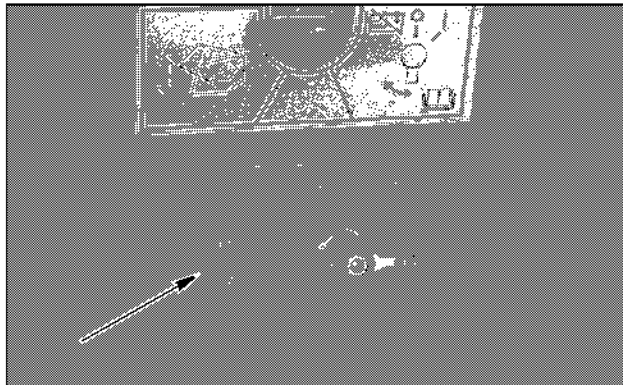

BD06F108

The master and hood raise switch are located in the right batter box. Raise the hood with the hood lift motor. Put master disconnect switch in OFF position. Remove both battery covers and disconnect batteries from the machine.

### STEP 5

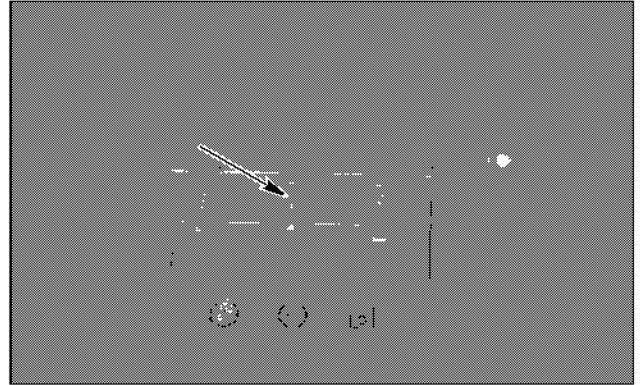

BD02N160

Put a 37 liter (10 gallon) container below radiator drain. Remove radiator cap. Remove cap and drain coolant into container. Install cap after coolant has drained. Install radiator cap.

### STEP 6

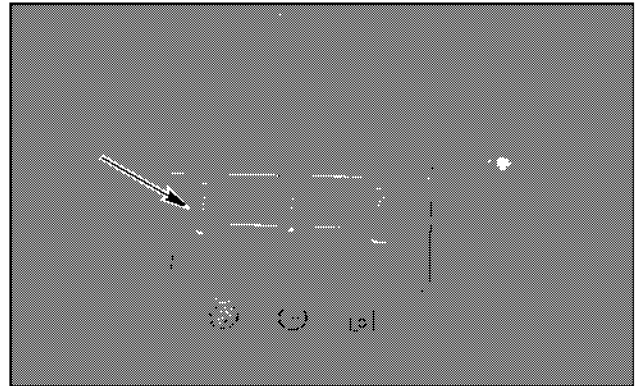

BD02N160

Put a 14.2 liter (15 U.S. quarts) container below engine oil drain. Remove cap and drain oil into container. Install cap after oil has drained.

**NOTE:** After draining oil disconnect drain hose from frame for removal with engine.

**STEP 60**

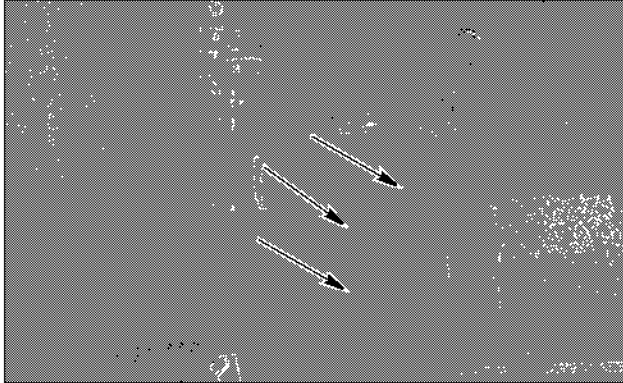

BD06F118

Connect the wiring to the alternator. Remove and discard tags.

**STEP 61**

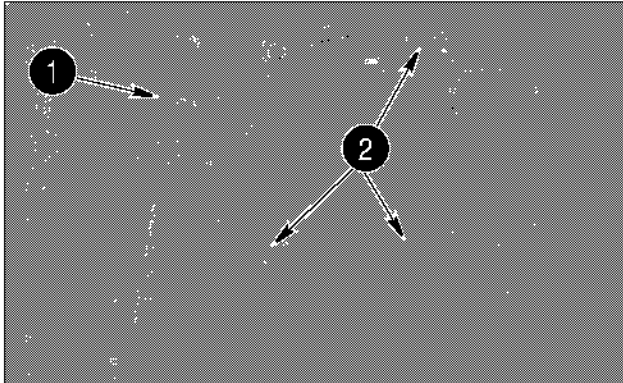

BD06F117

If loader is equipped with air conditioning, mount the compressor using the three mounting bolts (2), connect the engine wiring harness connectors to air compressor clutch connector (1). Remove and discard tags.

**STEP 62**

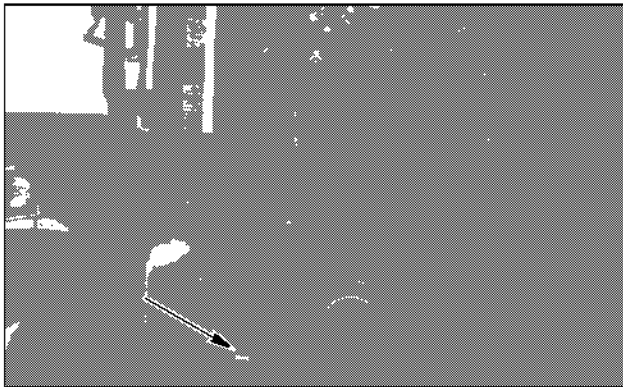

BD06F116

Install lower cooler hose to the engine and tighten the clamps to a torque of 10.1 to 11.3 Nm (90 to 100 lb-inch).

**STEP 63**

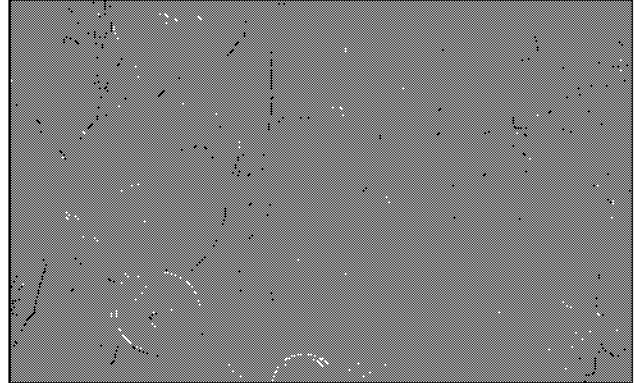

BD06F115

Install the drive belt.

**STEP 64**

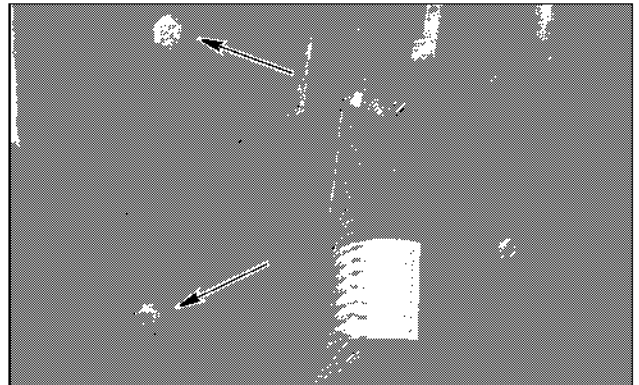

BD06F113

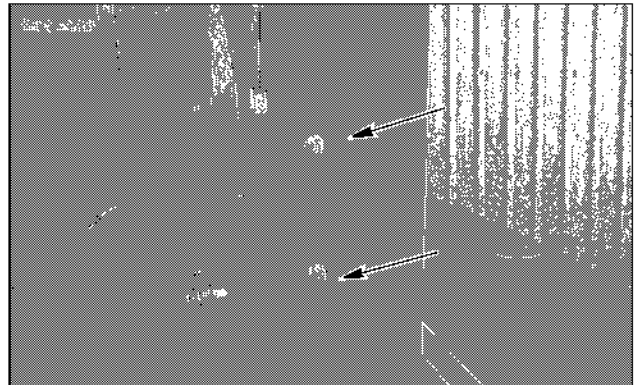

BD06F114

Install the cover mounting brackets to the machine frame. Install the belt cover, install the four mounting bolts for the belt cover.

# Section 2002

2002

## STALL TEST

## TROUBLESHOOTING AFTER COOLER

### STEP 1

Park machine on level ground, lower the bucket. Put transmission in neutral, apply the parking brake. Turn off engine.

### STEP 2

Raise hood. Install 'T' fitting in waste gate valve hose. Attach pressure gauge. Install another pressure gauge into the intake manifold port.

### STEP 3

Have assistant start engine and run at 2000 r/min (rpm). Record pressure readings for both gauges. If the pressure difference is greater than 60 mBar (0.87 psi), inspect cooler components for damaged or missing parts.

### STEP 4

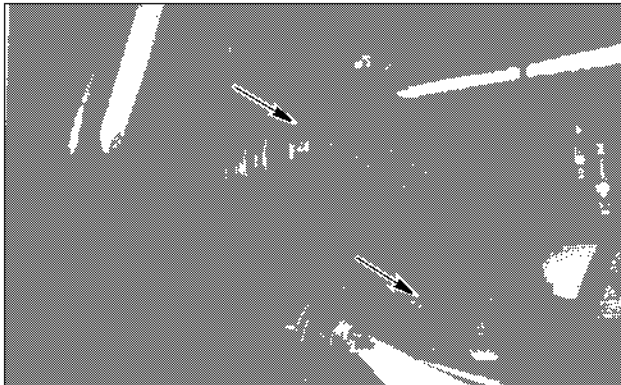

BD03A116

Inspect the turbocharger flex hose for leaks or holes and insure that the clamps are tight.

### STEP 5

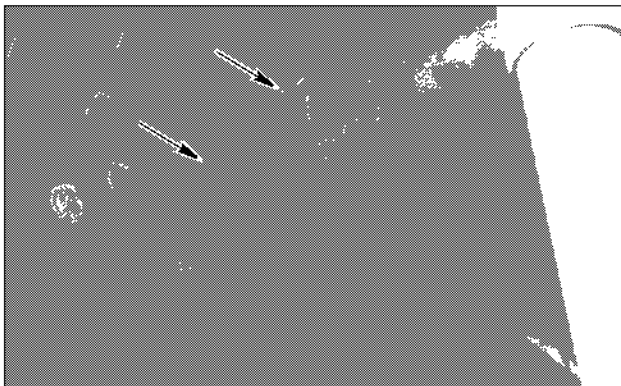

BD03A115

Inspect the after cooler inlet flex hose for leaks or holes and insure that the clamps are tight.

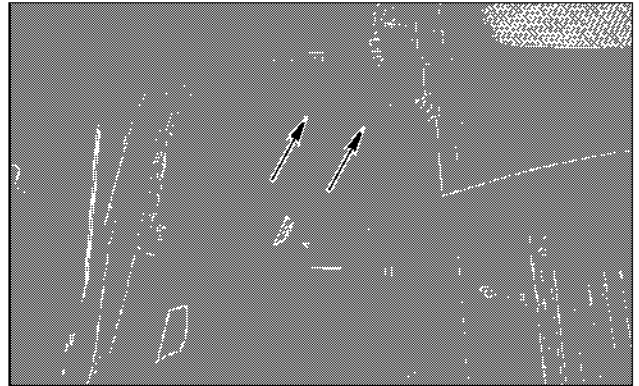

BD03A118

Inspect the after cooler outlet flex hose for leaks or holes and insure that the clamps are tight.

### STEP 6

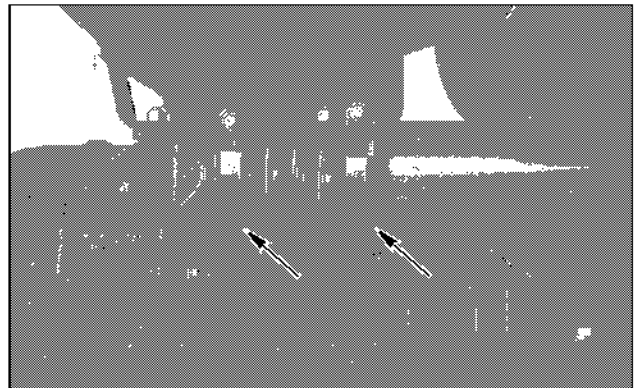

BD03A119

Inspect the intake manifold flex hose for leaks or holes and insure that the clamps are tight.

### STEP 7

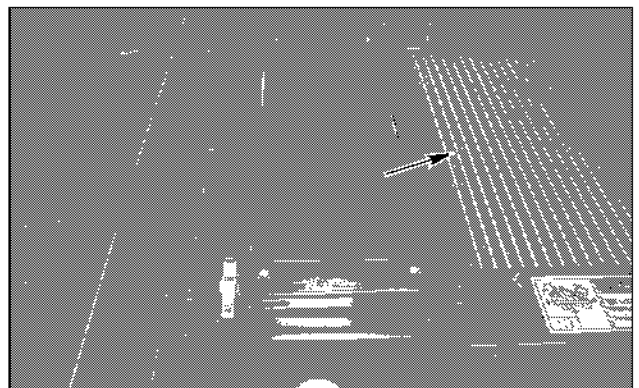

BD03A109

Visually inspect top of after cooler for damage or leaks

**NOTE:** *If the leak source has not been located, remove and test the after cooler.*

# Section 4001

## REMOVAL AND INSTALLATION OF STARTER AND ALTERNATOR

TRANSMISSION .....	62
Output Speed Sensor .....	63
Transmission Solenoid Valve and Temperature Sensors .....	63
Filter Maintenance Switch .....	63
Torque Converter Output Temperature Sender .....	63
Engine Speed Sensor .....	63
Intermediate Speed Sensor .....	63
Turbine Speed Sensor .....	63
Transmission Shifter .....	63
Transmission Electronic Control Module .....	63
Transmission Enable Switch .....	63
FNR Switch for Joystick Controls .....	63
Transmission Kick-down Switch (Located In Hydraulic Controller for Joystick Option; Next to Hydraulic Levers for Single Axis Controls) .....	63
FNR Switch for Single Axis Controls .....	63
Transmission Auto Switch .....	63
Brake Declutch Pressure Switch .....	63
Declutch Switch .....	63
Diagnostic Connector .....	63
WARNING BUZZER, INSTRUMENT CLUSTER 1, PARK BRAKE .....	64
Instrument Cluster Connector 1 .....	65
Warning Buzzer .....	66
Parking Brake Relay .....	66
Fuel Level Sender .....	67
Air Filter Restriction Switch .....	67
Parking Brake Solenoid .....	67
Radiator Coolant Temperature Sender .....	68
Brake Warning Pressure Switch .....	68
SWITCH PAD, INSTRUMENT CLUSTER 2, PARK BRAKE .....	69
Switch Pad .....	70
Instrument Cluster Connector 2 .....	71
Hydraulic Filter Restriction Switch .....	72
Hydraulic Oil Temperature Sender .....	72
Parking Brake Switch .....	73
Redundant Brake Pressure Switch 1 .....	73
Redundant Brake Pressure Switch 2 .....	73
Coolant Level Sender .....	74
BACK UP ALARM CONTROLS .....	75
Back-up Alarm Relay .....	76
Back-up Alarm Disable Switch .....	76
LIGHTS - 01 .....	77
Work Lamps Switch .....	78
Door Switch .....	78
Rotating Beacon (Option) .....	78
Dome Lamp .....	79
Beacon Switch (Option) .....	79
Left Hand Front Work Lamp .....	79
Right Hand Front Work Lamp .....	80
Left Hand Rear Work Lamp .....	80
Right Hand Rear Work Lamp .....	80
Lights Diodes .....	81
LIGHTS - 02 .....	82
Brake Lamp Pressure Switch .....	83
Brake Lamps Relay .....	83
Flasher Module .....	84
Hazard Switch .....	85

## Wire Identification Codes

Wire Identification Codes						
21C Bk - 1.0		Wire Size (mm <sup>2</sup> )				
Wire Color		Bk = Black	DU = Dark Blue	S = Gray	LG = Light Green	K = Pink
Wire Name		T = Tan	W = White	N = Brown	G = Green	U = Blue
		LU = Light Blue	Or = Orange	R = Red	P = Purple	Y = Yellow
Wire Identification			From Connector		To Connector	
Wire	Circuit	Color, Size, and Material	Connector	Cavity	Connector	Cavity
0 EA	Time Delay relay Control Grnd	Bk 0.8 GXL	GND-CAB-SPL2, Spl Back Light Ground	B	PRM-B2, PRM Signal	B
0 EB	Ignition Relay Control Ground	Bk 0.8 GXL	GND-CAB-SPL2, Spl Back Light Ground	C	PRM-A1, PRM Signal	B
0 EC	ACC Relay Control Ground	Bk 0.8 GXL	GND-CAB-SPL2, Spl Back Light Ground	D	PRM-D1, PRM Signal	B
0 ED	HVAC Grounds	Bk 3.0 SXL	HVAC2, HVAC2	2	GND-CAB4, Ground C	1
0 EE	DIODE Suppression Grounds	Bk 0.8 GXL	GND-CAB-SPL, Cab Grnd Spl	A	140M, DIODE Module	C
0 EF	Brake Lights Relay Ctrl Grnd	Bk 0.8 GXL	GND-CAB-SPL2, Spl Back Light Ground	M	ECC, Work Lights	B6
0 EG	Flasher Module Ground	Bk 0.8 GXL	FLSHR, Flasher Module	4	GND-CAB-SPL2, Spl Back Light Ground	L
0 EH	Flasher Module Ground	Bk 0.8 GXL	FLSHR, Flasher Module	3	GND-CAB-SPL2, Spl Back Light Ground	K
0 EJ	Power Converter Ground	Bk 1.0 GXL	CNV, 24V to 12V Pwr Convert	3	GND-CAB4, Ground C	1
0 EK	AUX Power Outlet 1 Grnd	Bk 1.0 GXL	PO1, Power Outlet	C	GND-CAB5, Ground C	1
0 EL	AUX Power Outlet 2 Grnd	Bk 1.0 GXL	PO2, Power Outlet	C	GND-CAB5, Ground C	1
0 EM	Radio Ground	Bk 0.8 GXL	CAB-RF, Cab to Roof Conn.	M	GND-CAB-SPL, Cab Grnd Spl	B
0 EN	Radio Ground	Bk 0.8 GXL	ROOF, Roof to Cab Conn.	M	RAD, Radio Power	8
0 EP	Horn Switch Ground	Bk 0.8 GXL	GND-CAB-SPL, Cab Grd Spl	C	SRHSTLK, RH Stalk Switch	31
0 EQ	Splice Pack GND-CAB-SPL2 Grnd	Bk 0.8 GXL	GND-CAB-SPL2, Spl Back Light Ground	H	GND-CAB6, Start, FFH, Water Sep Htr	1
0 ER	Power Converter Grnd	Bk 1.0 GXL	CNV, 24V to 12V Pwr Conv	6	GND-CAB4, Ground C	1
0 ES	Grid Heater Ground	Bk 19.0 SXL	GH-1, Grid Heater	1	GND-GH1, STRT, FFH, Water Sep Htr	1
0 GB	Starter Relay Control Ground	Bk 1.0 SXL	SRC-1, Relay	2	GND-ENG1, STRT, FFH, Water Sep Htr	1
0 HC	Trans Splice Grounds	Bk 1.0 SXL	SPL-TRN-GND, Spl Trans Ground	A	TRAN-E, Trans to Engine	2
0 HD	Speed Sensor Grounds	Bk 1.0 SXL	TRANS, Cab Transmission	11	SPL-H2, Ultrasonic	A
0 HE	Output Speed Sensor Grnd	Bk 1.0 SXL	TRANS, Cab Transmission	28	OSS, Out Speed Sensor	1
0 HF	Engine Speed Sensor Grnd	Bk 0.8 GXL Twist	ESS, Engine Speed Sensor	2	SPL-H2, Ultrasonic	A

## Wire Identification Codes

Wire Identification Codes						
21C Bk - 1.0		Wire Size (mm <sup>2</sup> )				
Wire Color		Bk = Black	DU = Dark Blue	S = Gray	LG = Light Green	K = Pink
Wire Name		T = Tan	W = White	N = Brown	G = Green	U = Blue
		LU = Light Blue	Or = Orange	R = Red	P = Purple	Y = Yellow
Wire Identification			From Connector		To Connector	
Wire	Circuit	Color, Size, and Material	Connector	Cavity	Connector	Cavity
21F B	EDC7 Digital Ground	W 0.8 TXL	SPL-EDC3, Ultrasonic	A	EDC7, Engine Controller	29
21F C	EDC7 Digital Ground	W 0.8 TXL	RTHP, Throttle Pedal	1	SPL-EDC3, Ultrasonic	A
21G	EDC7 Crank Control relay	W 0.8 GXL	CAB-E, Cab Engine	3	ECB, Elect Center B	AA10
21G A	EDC7 Crank Control relay	W 0.8 TXL	ENG, Engine Cab	3	EDC7, Engine Controller	37
21H	Crank control relay LSD	W 0.8 GXL	CAB-E, Cab Engine	4	ECB, Elect Center B	A9
21H A	Crank control relay LSD	W 0.8 TXL	ENG, Engine Cab	4	EDC7, Engine Controller	17
21K	Ign Sw Start Signal	W 0.8 GXL	S-KEY, Ignition Switch	2	SPL-CRK, Ultrasonic	A
21K A	Ign Sw Start Signal	W 0.8 TXL	SPL-CRK, Ultrasonic	A	AIC-2, Adv Instrument Cluster 2	17
21K B	Ign Sw Start Signal	W 0.8 GXL	SPL-CRK, Ultrasonic	A	ECB, Elect Center B	B3
24B	Throttle Signal	W 0.8 TXL	RTHP, Throttle Pedal	3	EDC7, Engine Controller	79
24B A	Throttle Signal	W 0.8 TXL	RTHP, Throttle Pedal	3	QSM11, Engine Controller	47
24L	Low Idle Sw	W 0.8 TXL	RTHP, Throttle Pedal	6	EDC7, Engine Controller	48
24R	Throttle Pos Sens Grnd	W 0.8 TXL	RTHP, Throttle Pedal	4	EDC7, Engine Controller	78
24R A	Throttle Pos Sens Grnd	W 0.8 TXL	RTHP, Throttle Pedal	4	QSM11, Engine Controller	49
24S	Throttle Supply	W 0.8 TXL	RTHP, Throttle Pedal	5	EDC7, Engine Controller	77
24S A	Throttle Supply	W 0.8 TXL	RTHP, Throttle Pedal	5	QSM11, Engine Controller	48
25A	Eng Speed Sig	W 0.8 GXL Twist	TRANS, Cab Transmission	7	ESS, Engine speed Sensor	1
25A A	Eng Speed Sig	LU 0.8 TXL	CAB-T, Cab Transmission	7	TECM, Trans	19
25B	Int Speed Sig	W 0.8 GXL Twist	TRANS, Cab Transmission	9	ISS, Int Speed Sensor	1
25B A	Int Speed Sig	LU 0.8 TXL	CAB-T, Cab Transmission	9	TECM, Trans	42
25C	Turbine Speed Sig	W 0.8 GXL Twist	TRANS, Cab Transmission	8	TSS, Turbine Speed Sensor	1
25C A	Turbine Speed Sig	LU 0.8 TXL	CAB-T, Cab Transmission	8	TECM, Trans	41
25D	Output Speed Sig	LU 1.0 SXL	TRANS, Cab Transmission	10	OSS, Output Speed Sensor	2
25D A	Output Speed Sig	LU 0.8 TXL	CAB-T, Cab Transmission	10	TECM, Trans	62
25F	Forward Signal	LU 0.8 TXL	TS1, Transmission Shifter	B	TECM, Trans	43
25G	Brake Declutch Switch	LU 1.0 SXL	FRONT, Cab Front Chassis	28	PBD, Declutch Pressure Switch	B
25G A	Brake Declutch Switch	LU 0.8 GXL	CAB-F, Cab Front Chassis	28	SPL-DC, Ultrasonic	A
25G B	Brake Declutch Switch	LU 0.8 GXL	SDC, Declutch Switch	1	SPL-DC, Ultrasonic	A
25G C	Brake Declutch Switch	LU 0.8 TXL	SPL-DC, Ultrasonic	A	TECM, Trans	66

## Wire Identification Codes

21C Bk - 1.0

 Wire Size (mm<sup>2</sup>) 0.8 mm 1.0 mm 2.0 mm 5.0 mm

Wire Color	Bk = Black	DU = Dark Blue	S = Gray	LG = Light Green	K = Pink
	T = Tan	W = White	N = Brown	G = Green	U = Blue
	LU = Light Blue	Or = Orange	R = Red	P = Purple	Y = Yellow

Wire Identification			From Connector		To Connector	
Wire	Circuit	Color, Size, and Material	Connector	Cavity	Connector	Cavity
55A C	RTT Float Sw Power	W 0.8 GXL	SFL, Return to Travel Switch	3	SPL-RTT, Ultrasonic	A
55B	RTT Float Switch Control	W 0.8 GXL	SFL, Return to Travel Switch	5	EM, RTD Height Control RTT	6
56 A	Fan Control PWM	W 1.0 SXL	ENG, Engine Cab	23	YFN, Fan PWM Solenoid	A
57 A	Pin Engage Sol Pwr	W 0.8 GXL	CAB-F, Cab Front Chassis	20	SPL-PINE, Ultrasonic	A
57 B	Pin Engage Sol Pwr	W 0.8 GXL	SPE, Pin Engage Switch	1	SPL-PINE, Ultrasonic	A
57 C	Pin Engage Sol Pwr	W 0.8 TXL	SPL-PINE, Ultrasonic	A	AIC-2, Adv Instrument Cluster 2	16
58C	Ride Control Switch Jumper	W 0.8 GXL	SRC, Ride Control Switch	5	SRC, Ride Control Switch	3
58H A	Ride Control Sw Pwr VPS2	W 0.8 TXL	TECM, Trans	8	ECD, Elect Center D	D7
58L	Ride Control Relay LSD	Bk 0.8 TXL	TECM, Trans	57	ECD, Elect Center D	B8
58S E	Ride Control Sol to Front Cab	W 1.0 SXL	FRONT, Cab Front Chassis	21	YRC, Ride Control Option	1
58T	Ride Control Relay Sw Pwr	W 0.8 GXL	SRC, Ride Control Switch	4	ECD, Elect Center D	B7
58 A	Ride Control Sol Pwr	W 1.0 SXL	202M, Rollback Jumper	A	202M, Rollback Jumper	B
58 B	Ride Control Sol Pwr	W 1.0 SXL	FRONT, Cab Front Chassis	21	PRBF, Rollback Pressure Switch	B
58 C	Ride Control Sol Pwr	W 0.8 GXL	CAB-F, Cab Front Chassis	21	SPL-D26, Ultrasonic	A
58 D	Ride Control Sol Pwr	W 0.8 GXL	140M, Diode Module	D	SPL-D26, Ultrasonic	A
58 E	Ride Control Sol Pwr	W 0.8 GXL	SPL-D26, Ultrasonic	A	ECD, Elect Center D	D8
58 F	Ride Control Sol Pwr	W 0.8 GXL	SRC, Ride Control Switch	6	SPL-D26, Ultrasonic	A
59D	Hood Relay Control Down	W 1.0 GXL	CAB-E, Cab Engine	37	ECC, Work Lights	D3
59D A	Hood Relay Control Down	W 1.0 SXL	ENG, Engine Cab	37	HD, Hood Switch	A
59U	Hood Relay Control Up	W 1.0 GXL	CAB-E, Cab Engine	39	ECC, Work Lights	D1
59U A	Hood Relay Control Up	W 1.0 SXL	ENG, Engine Cab	39	HD, Hood Switch	C
60D	Hood Down Relay Out	W 1.0 GXL	CAB-E, Cab Engine	36	ECC, Work Lights	B3
60D A	Hood Down Relay Out	W 1.0 SXL	ENG, Engine Cab	36	HDM, Hood Lift Motor	2
60U	Hood Up Relay Out	W 1.0 GXL	CAB-E, Cab Engine	38	ECC, Work Lights	B1
60U A	Hood Up Relay Out	W 1.0 SXL	ENG, Engine Cab	38	HDM, Hood Lift Motor	1
61A	Trinary Press Sw Input	W 1.0 SXL	ENG, Engine Cab	30	PR, Trinary Press Sw	A
61A B	Trinary Press Sw Input	W 0.8 GXL	CAB-E, Cab Engine	30	HVAC1, HVAC1	1
61C	AC Relay Out	Or 0.8 GXL	CAB-E, Cab Engine	2	ECD, Elect Center D	D10
61C A	AC Relay Out	Or 1.0 SXL	ENG, Engine Cab	2	ACT, AC Comp Clutch	1
61C B	AC Relay Out	Or 1.0 SXL	ENG, Engine Cab	2	ACT-9, AC Comp Clutch	1
61R	AC Relay Control	W 1.0 SXL	ENG, Engine Cab	29	PR, Trinary Press Sw	B

## 9 – Starter Motor

Located on left side of engine, open engine compartment to gain access.

Check Points	Correct Reading	Possible Cause of Bad Reading
Between housing of starter and ground	Continuity	Bad ground connection.

**NOTE:** Put the master disconnect switch in the ON position.

Starter B+ stud to ground	24 volts	Check circuit to batteries.
---------------------------	----------	-----------------------------

**NOTE:** Put the transmission in NEUTRAL. Have another person hold the ignition switch in the START position.

Terminal S to ground	24 volts	Bad starting relay (1). Also check wire 1-BB between starter and starting relay (1).
----------------------	----------	--

**NOTE:** If the readings are good, repair or replace the starter.

## 10 – Ignition Switch

Located on steering column.

Check Points	Correct Reading	Possible Cause of Bad Reading
--------------	-----------------	-------------------------------

**NOTE:** Put the master disconnect switch in the ON position.

Terminal for wire 1A to ground	24 volts	Check circuit 1A to ECC-F5 fuse.
--------------------------------	----------	----------------------------------

**NOTE:** Disconnect the connector from the ignition switch. Turn the switch to ON.

Between Bat and Ign	Continuity	Bad ignition switch.
---------------------	------------	----------------------

Between Bat and Accessory	Continuity	Bad ignition switch.
---------------------------	------------	----------------------

**NOTE:** Hold the ignition switch in the START position.

Between Bat and Starter	Continuity	Bad ignition switch.
-------------------------	------------	----------------------

Between Bat and Ign	Continuity	Bad ignition switch.
---------------------	------------	----------------------

**NOTE:** Put the switch in the Accessory position.

Between Bat and Accessory	Continuity	Bad ignition switch.
---------------------------	------------	----------------------

## 25 – Return-To-Travel/Float Switch

Located on right side console.

Check Points	Correct Reading	Possible Cause of Bad Reading
Terminal for wire 0-B2 to ground	Continuity	Bad ground circuit.
Terminal for wire 0-29 to ground	Continuity	Bad ground circuit.

**NOTE:** Disconnect the wiring harness connector from the return-to-travel/float switch. Put the return-to-travel/float switch in FLOAT position.

Between switch terminals 1 and 2	Continuity	Bad return-to-travel/float switch.
----------------------------------	------------	------------------------------------

**NOTE:** Put the return-to-travel/float switch in the TRAVEL position.

Between switch terminals 2 and 3	Continuity	Bad return-to-travel/float switch.
----------------------------------	------------	------------------------------------

**NOTE:** Put ignition switch in OFF position. Connect wiring harness connector to return-to-travel/float switch. Put ignition switch in ON position. Put driving lamp switch (95) in position 3.

Terminal for wire 49-K to ground	24 volts	Bad circuit 49-K. Also check driving lamp switch (95). If return-to-travel/float switch illumination LED is not ON with 24 volts at check point, replace return-to-travel/float switch.
----------------------------------	----------	---

## 26 – Height Control Switch

Located on right side console.

Check Points	Correct Reading	Possible Cause of Bad Reading
Terminals for wire 0-B3 to ground	Continuity	Bad ground circuit.

**NOTE:** Turn the master disconnect to the ON position, the ignition switch to the ON position and the pilot control switch to the ON position.

Terminal for wire 53P-D to ground.	24 volts	Bad pilot control relay (29), check fuse ECA-F5.
------------------------------------	----------	--

**NOTE:** Turn the height control switch to the ON position.

Terminal for wire 54A to ground.	24 volts	Bad height control switch.
----------------------------------	----------	----------------------------

---

**NOTE:** *If you have transmission shifting problems, see Section 6002 for complete troubleshooting information for Items 45 through 61.*

---

**45 – Output Speed Sensor**

**46 – Transmission Solenoid Valve and Temperature Sensors**

---

**47 – Filter Maintenance Switch**

---

**48 – Torque Converter Output Temperature Sender**

**49 – Engine Speed Sensor**

---

**50 – Intermediate Speed Sensor**

---

**51 – Turbine Speed Sensor**

**52 – Transmission Shifter**

---

**53 – Transmission Electronic Control Module**

---

**54 – Transmission Enable Switch**

**55 – FNR Switch for Joystick Controls**

---

**56 – Transmission Kick-down Switch (Located In Hydraulic Controller for Joystick Option; Next to Hydraulic Levers for Single Axis Controls)**

---

**57 – FNR Switch for Single Axis Controls**

---

**58 – Transmission Auto Switch**

**59 – Brake Declutch Pressure Switch**

---

**60 – Declutch Switch**

---

**61 – Diagnostic Connector**

## 74 – Parking Brake Switch

Located on steering column.

Check Points	Correct Reading	Possible Cause of Bad Reading
Terminal for wire 0-B29 to ground	Continuity	Bad ground circuit.
<b>NOTE:</b> Put the master disconnect switch and the ignition switch in the ON position.		
Terminal for wire 19A-L to ground	24 volts	Check fuse ECA-F1, also check circuit 19A.
<b>NOTE:</b> Apply parking brake switch.		
Terminal for wire 33U to ground	24 volts	Bad parking brake switch.
<b>NOTE:</b> Put the driving lamp switch (95) in position 3, 4, or 5.		
Terminal for wire 49-V to ground	24 volts	Bad driving lamp switch. Also check fuse ECC-F3 and circuits 41 and 19Z.
<b>NOTE:</b> If 24 volts between wire 49 and ground and parking brake switch is not illuminated, replace parking brake switch.		

## 75 – Redundant Brake Pressure Switch 1

Located on steel lines at accumulators.

Check Points	Correct Reading	Possible Cause of Bad Reading
<b>NOTE:</b> Redundant brake switch close at 62 bar (900 psi).		
Terminal for wires 0-HM to ground	Continuity	Bad ground circuit.
<b>NOTE:</b> Put the master disconnect switch and the ignition switch in the ON position.		
Terminal A for wire 33R-C to ground	Approximately 11.5 volts	Bad instrument cluster (62), also check circuit 33R.
<b>NOTE:</b> If the readings are good, replace the redundant brake pressure switch(es).		

## 76 – Redundant Brake Pressure Switch 2

Located on steel lines at accumulators.

Check Points	Correct Reading	Possible Cause of Bad Reading
<b>NOTE:</b> Redundant brake switches close at 62 bar (900 psi).		
Terminal for wires 0-HL to ground	Continuity	Bad ground circuit.
<b>NOTE:</b> Put the master disconnect switch and the ignition switch in the ON position.		
Terminal A for wires 33R-B to ground	Approximately 11.5 volts	Bad instrument cluster (62), also check circuit 33R.
<b>NOTE:</b> If the readings are good, replace the redundant brake pressure switch(es).		

## 90 – Brake Lamp Pressure Switch

Located on the foot brake valve.

Check Points	Correct Reading	Possible Cause of Bad Reading
<b>NOTE:</b> Put master disconnect switch in ON position.		
Terminal for wire 1-AA to ground	24 volts	Check fuse ECC-F4, also check wires 1-AA and 1-DR.
Terminal for wire 44 to ground	0 volt	Bad brake lamp pressure switch.
<b>NOTE:</b> Put ignition switch in ON position. Have another person press and hold down brake pedal.		
Terminal for wire 44 to ground	24 volts	Bad brake lamp pressure switch.

## 91 – Brake Lamps Relay

Located in the cab access panel for fuses and relays.

Check Points	Correct Reading	Possible Cause of Bad Reading
Terminal for wire 0-EF to ground	Continuity	Bad ground circuit.
<b>NOTE:</b> Put master disconnect switch in ON position.		
Terminal for wire 1-DW to ground	24 volts	Check fuse ECC-F4 and wires 1-DW and 1-DV.
Terminal for wire 44A to ground	0 volt	Bad brake lamp pressure switch (90).
Terminal for wire 44A-A to ground	0 volt	Bad brake lamps relay.
<b>NOTE:</b> Put ignition switch in ON position. Have another person press and hold down brake pedal.		
Terminal for wire 44A to ground	24 volts	Bad brake lamp pressure switch (90).
Terminal for wire 44A-A to ground	24 volts	Bad brake lamps relay.

## 100 – Right Hand Rear Combination Lamp (Europe Only)

Located on the right rear of the machine.

Check Points	Correct Reading	Possible Cause of Bad Reading
<b>NOTE:</b> <i>Disconnect wiring harness connector LRR-E from RH rear combination lamp connector.</i>		
Combination lamp connector pin 1 to pin 5	Continuity	Bad stop lamp bulb.
Combination lamp connector pin 2 to pin 5	Continuity	Bad turn lamp bulb.
Combination lamp connector pin 3 to pin 5	Continuity	Bad tail lamp bulb.
Combination lamp connector pin 4 to pin 5	Continuity	Bad reverse lamp bulb.
<b>NOTE:</b> <i>Connect wiring harness connector LRR-E to RH rear combination lamp connector.</i>		
Terminal for wire 0-BR to ground	Continuity	Bad ground circuit.
<b>NOTE:</b> <i>Put master disconnect switch and ignition switch in ON position. Have another person press and hold down the brake pedal.</i>		
Terminal for wire 44A-F to ground	24 volts	Check brake lamps relay (91). Also check circuit 44 to brake lamps relay (91).
<b>NOTE:</b> <i>Have assistant put transmission in reverse.</i>		
Terminal for wire 35A-K to ground	24 volts	Check backup alarm relay (78). Also check circuit 35A to backup alarm relay (78).
<b>NOTE:</b> <i>Have assistant put transmission in neutral. Put turn signal lever in RIGHT turn position.</i>		
Terminal for wire 45R-A to ground	Intermittent 24 volts	Check the turn signal switch (94) and flasher module (92). Also check circuit 45R to flasher module.
<b>NOTE:</b> <i>Put driving lamp switch (95) in position 2 or 3.</i>		
Terminal for wire 18G-A to ground	24 volts	Check fuse ECB-F8 and lamp switch (95). Also check circuit 18G.
<b>NOTE:</b> <i>If all readings are good, and lamps still do not turn ON replace the RH rear combination lamp.</i>		

## 113 – Wiper Diodes

Located in the cab access panel for fuses and relays, rear of compartment.

Check Points	Correct Reading	Possible Cause of Bad Reading
<b>NOTE:</b> <i>Disconnect wiring harness connector 140M from diode connector.</i>		
Multimeter positive on pin A to pin C	None	Bad diode.
Multimeter positive on pin B to pin C	None	Bad diode.
Multimeter positive on pin D to pin C	None	Bad diode.
Multimeter positive on pin E to pin C	None	Bad diode.
Multimeter positive on pin F to pin C	None	Bad diode.
Multimeter positive on pin C to pin A	Continuity	Bad diode.
Multimeter positive on pin C to pin B	Continuity	Bad diode.
Multimeter positive on pin C to pin D	Continuity	Bad diode.
Multimeter positive on pin C to pin E	Continuity	Bad diode.
Multimeter positive on pin C to pin F	Continuity	Bad diode.

## AIR SEAT - CIGAR LIGHTER - AIR CONDITIONING COMPRESSOR

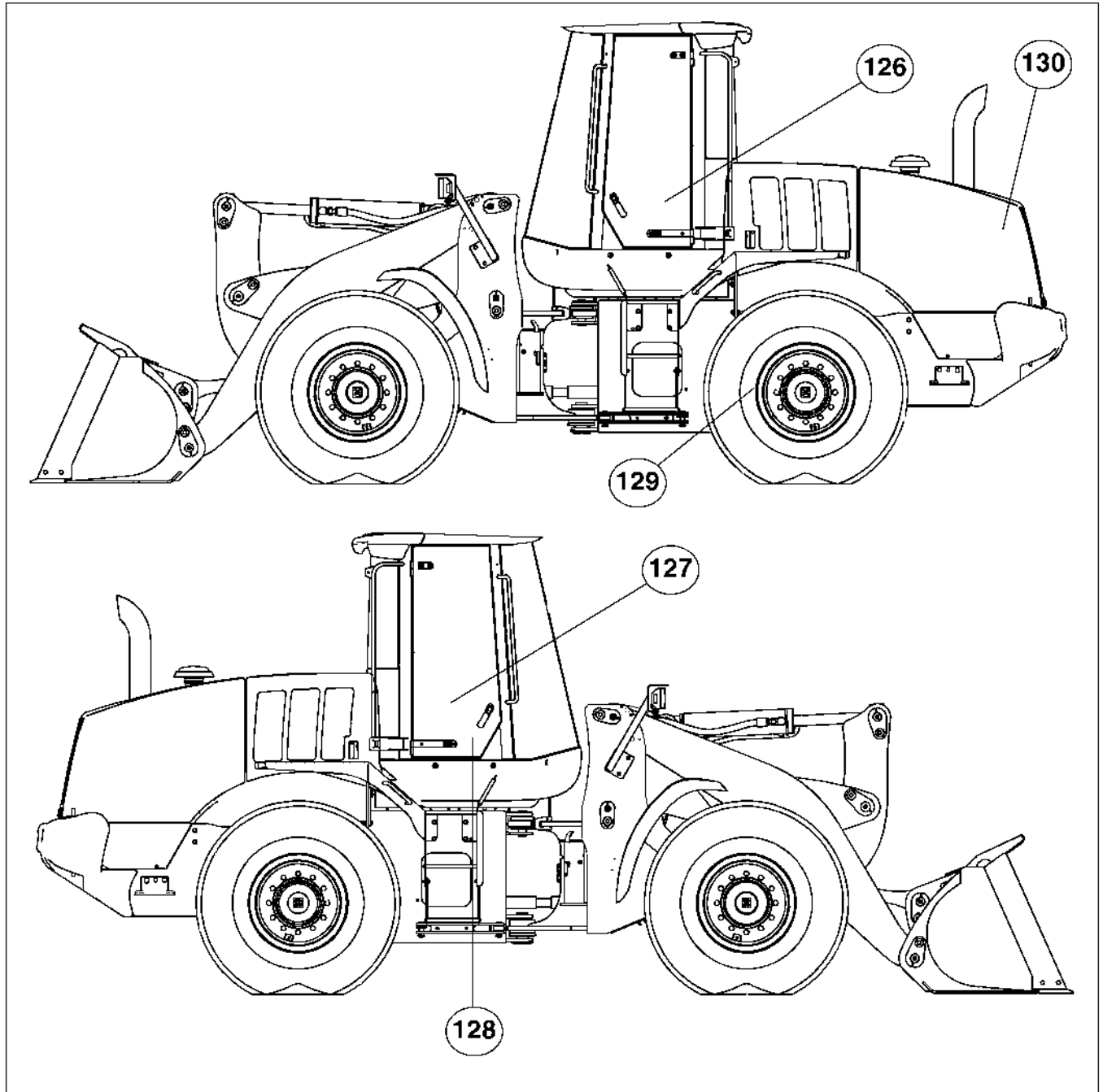

BS06H241 / BS06H242

126.AIR SEAT

127.CIGAR LIGHTER

128.AIR CONDITIONING CLUTCH REALY

129.HIGH/LOW SWITCH

130.AIR CONDITIONING COMPRESSOR CLUTCH

**NOTE:** The battery must be at full charge and all connections clean and tight before doing any testing of the electrical system. Use a Multimeter for the following tests.

---

## 145 – Hood Motor

---

Located in the left side of the engine compartment.

Check Points	Correct Reading	Possible Cause of Bad Reading
<b>NOTE:</b> Turn the master disconnect switch ON and disconnect connector HDM. Hold the hood switch (144) in the raise position.		
Terminal for wire 60U-A	24 volts	Bad hood up relay (142), bad hood switch (144), and check fuse ECC-F7.
<b>NOTE:</b> Hold the hood switch (144) in the lower position.		
Terminal for wire 60D-A	24 volts	Bad hood down relay (143), bad hood switch (144), and check fuse ECC-F7.
<b>NOTE:</b> If all readings are good replace the hood motor.		

---

**CONNECTOR DNS-RESISTOR**

**ART NOT AVAILABLE**

CAV	WIRE IDENT	CIRCUIT
1	DNS61	
2	DNS62	
3	DNS63	
4	DNS64	
5	Not used	

**CONNECTOR DNS-ELECT-WATER-VALVE-S**

**ART NOT AVAILABLE**

CAV	WIRE IDENT	CIRCUIT
1	DNS60	
2	Not used	
3	DNS56	
4	DNS57	
5	DNS58	
6	DNS59	

**CONNECTOR DNS-DRIVER**

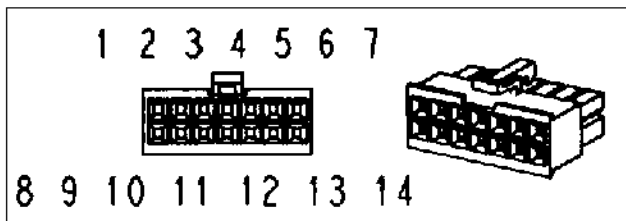

411311A1

CAV	WIRE IDENT	CIRCUIT
2	DNS50	
3	DNS52	
4	DNS49	
5	DNS48	
6	DNS55	
7	DNS57	
8	DNS58	
9	DNS59	
11	DNS51	
12	DNS53	
13	DNS54	
14	DNS56	

**CONNECTOR DNS-HVAC1-S**

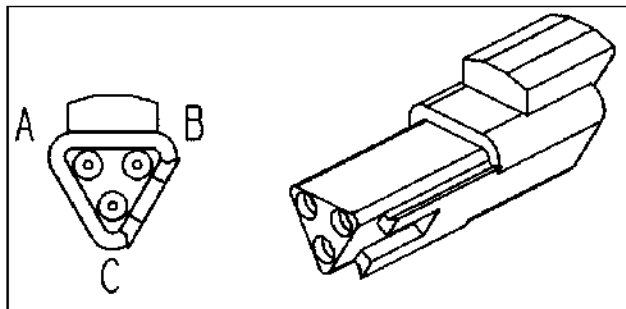

225294C1

CAV	WIRE IDENT	CIRCUIT
A	DNS67	
B	DNS76	
C	DNS69	

**CONNECTOR DNS-HVAC2-S**

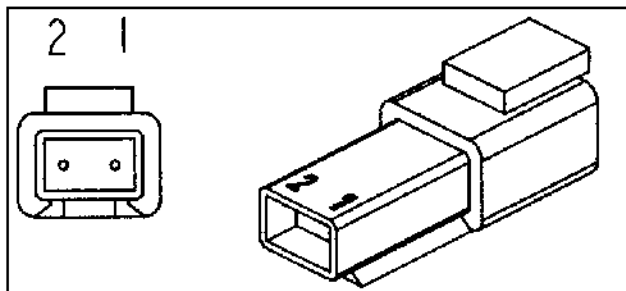

225315C1

CAV	WIRE IDENT	CIRCUIT
1	DNS74	
2	DNS75	

**CONNECTOR FWM - FRONT WIPER MOTOR**

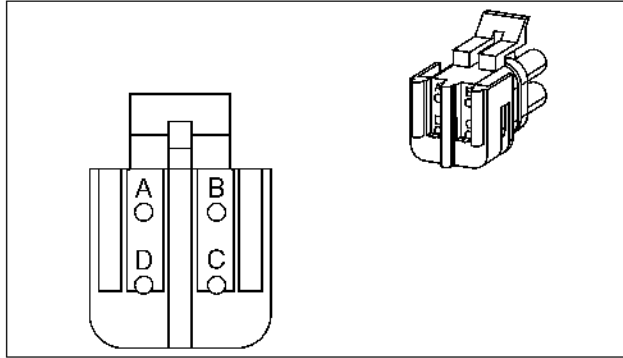

245715C1

CAV	WIRE IDENT	CIRCUIT
A	63H-A	Front Wiper High Speed Rly Out
B	63L-A	Front Wiper Low Speed Rly Out
C	19J-A	Front Wiper Motor Fused Power
D	63C	Front Wiper Park Control

**CONNECTOR FWW - FRONT WASHER**

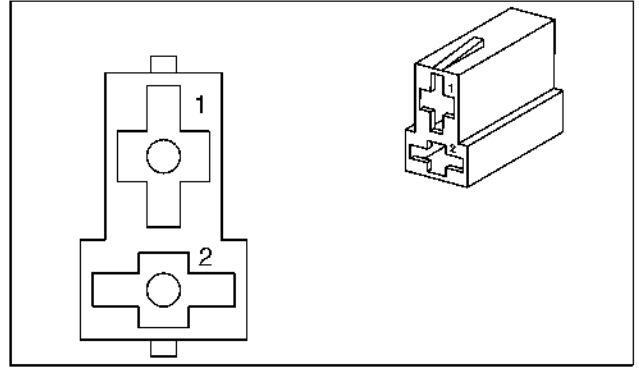

3227856R1

CAV	WIRE IDENT	CIRCUIT
1	63W-A	Front Washer Pump
2	0-B	Front Washer Ground

**CONNECTOR FWMG - FRONT WIPER MOTOR GROUND**

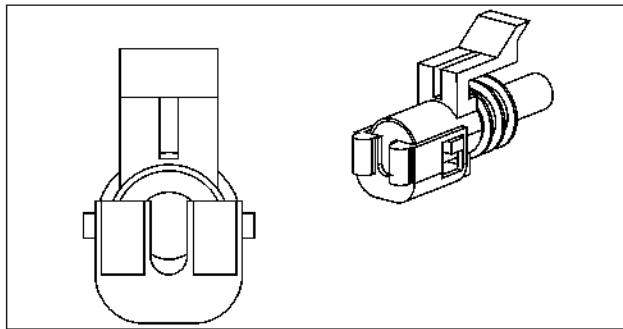

245480C1

CAV	WIRE IDENT	CIRCUIT
1	0-B8	Front Wiper Ground

**CONNECTOR GHC - GRID HEATER RELAY**

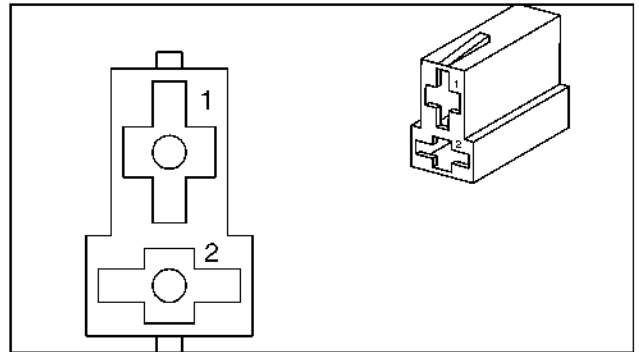

3227856R1

CAV	WIRE IDENT	CIRCUIT
1	28G	Grid Heater Source DR
2	0-BV	Grid Heater Control Ground

**CONNECTOR PRM-C2 - PRM SIGNAL**

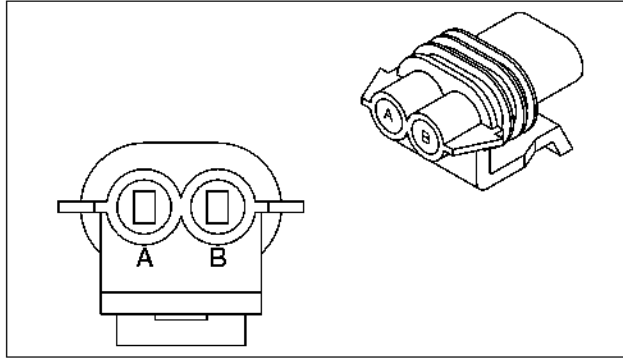

256340A1

CAV	WIRE IDENT	CIRCUIT
A	28E	Either Relay Signal
A	28F	Fuel Filter Heater Relay Control
B	0-BAM	Either Relay Signal Ground
B	0-BN	Filter Heater Control ground

**CONNECTOR PRM-D1 - PRM SIGNAL**

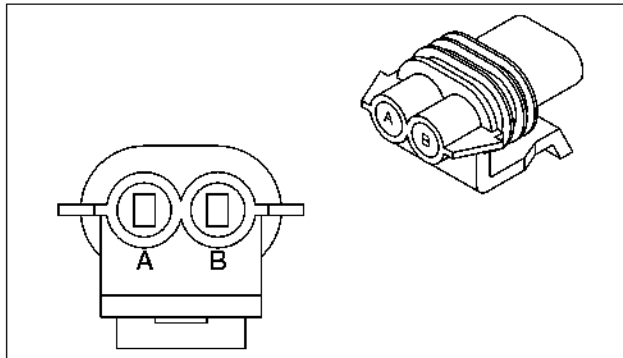

256340A1

CAV	WIRE IDENT	CIRCUIT
A	12ACC-B	ACC PRM Control Power
B	0-EC	ACC Relay Control Ground

**CONNECTOR PRM-E1 - PRM SIGNAL**

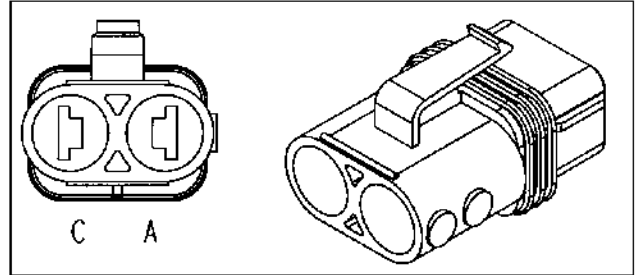

409084A1

CAV	WIRE IDENT	CIRCUIT
A		Not Used
C	19L	Power Converter FSD Power

**CONNECTOR PRM-E2 - PRM SIGNAL**

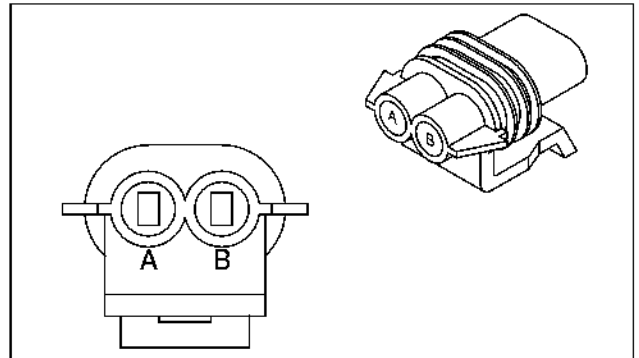

256340A1

CAV	WIRE IDENT	CIRCUIT
A	12ACC-C	Pwr Converter PRM Control Pwr
B	0-DL	Pwr Converter Relay Ctrl Gnd

**CONNECTOR PSS - SECONDARY STEERING PRESSURE SWITCH**

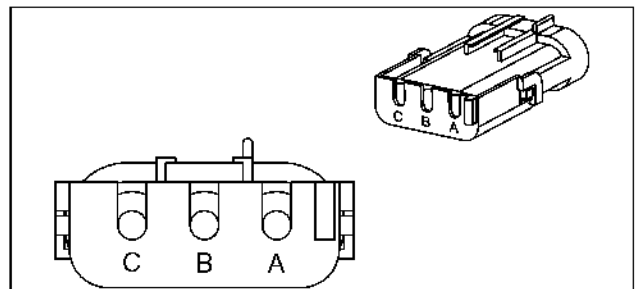

245485C1

CAV	WIRE IDENT	CIRCUIT
A	51P-A	Secondary Steer High Pressure
B	0-CC	Sec. Steer Press Switch Ground
C	35X-A	Secondary Steer Low Press Sig

**CONNECTOR SPL-BCK-LT-GD2 - SPLICE BACK LIGHT GROUND**

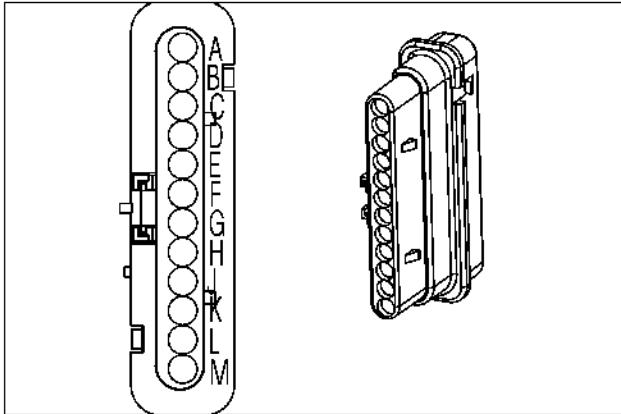

87324393

CAV	WIRE IDENT	CIRCUIT
A		Not Used
B	0-B2	Back Light Ground
C	0-B3	Back Light Ground
D	0-B4	Back Light Ground
E	0-B5	Back Light Ground
F	0-B6	CAB2 Ground
G	0-B26	Buzzer Switch Pad Ground
H		Not Used
J	0-B20	Back Light Ground
K	0-29	RTT/Float Ground
L	0-B11	Back Light Ground
M	0-B7	Back Light Ground

CAV	WIRE IDENT	CIRCUIT
D	0-BS	Fan Control Ground
E	0-B	Front Washer Ground
F	0-BL	Rear Washer Ground

**CONNECTOR SPL-HOOD-GND - HOOD GROUND 6 PACK**

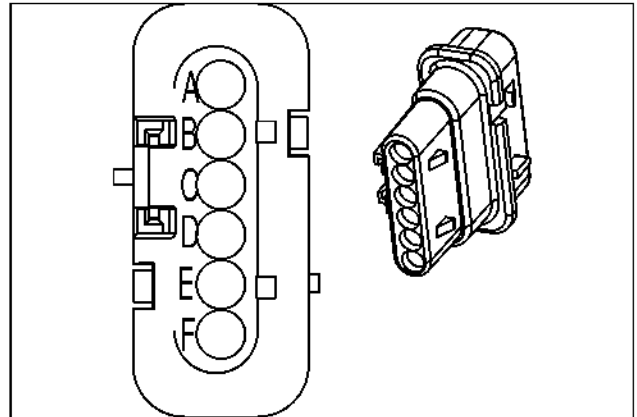

87324391

CAV	WIRE IDENT	CIRCUIT
A	0-B12	Hood Down Relay Ground
B	0-B16	Hood Down Control Ground
C	0-B22	Hood Up Relay Ground
D	0-B25	Hood Up Control Ground
E	0-B10	Hood Ground
F		Not Used

**CONNECTOR SPL-ENG-GND - GROUND SPLICE 6 PACK**

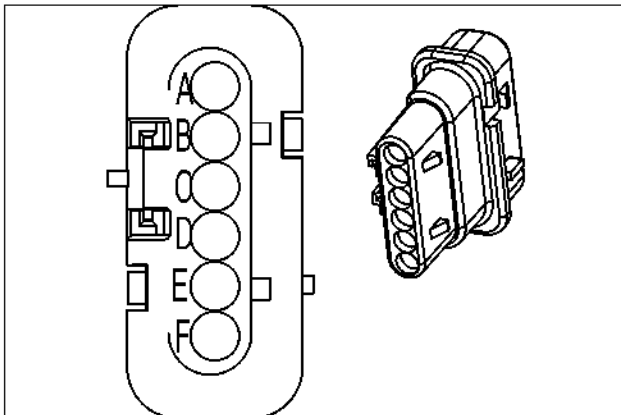

87324391

CAV	WIRE IDENT	CIRCUIT
A	0-BM	Engine Splice Grounds
B	0-BY	Air Filter Restriction Switch Gnd
C		Not Used

**CONNECTOR TRC - TRANSMISSION CONTROL**

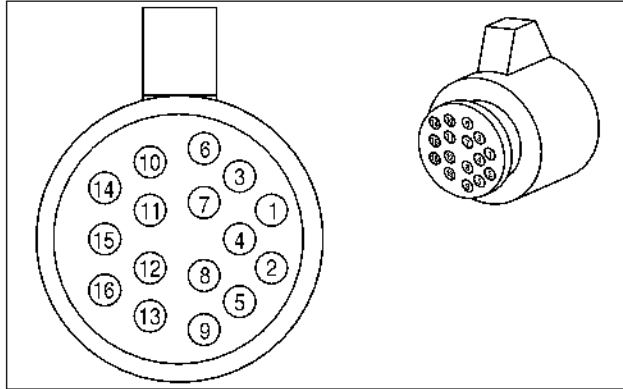

371566A1

CAV	WIRE IDENT	CIRCUIT
1	25K	Trans Solenoid Valve Y1
1	25L-9	Trans Solenoid Valve Y1
2	25K-9	Trans Solenoid Valve Y2
2	25L	Trans Solenoid Valve Y2
3	25M	Trans Solenoid Valve Y3
4	25N	Trans Solenoid Valve Y4
5	25P	Trans Solenoid Valve Y5
6	25J	Trans Solenoid Valve Y6
7	25S	Output Sw Power VPS1
8	36T	Valve Body Temp Signal
9	36R-C	Valve Body Temp Return
10		Not Used
11		Not Used
12		Not Used
13		Not Used
14		Not Used
15		Not Used
16		Not Used

**CONNECTOR TS1 - TRANSMISSION SHIFTER**

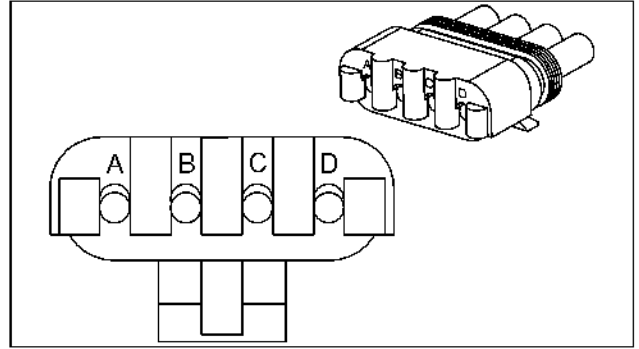

245486C1

CAV	WIRE IDENT	CIRCUIT
A	19A-H	Trans Shifter Fused Power
B	25F	Forward Signal
C	25R	Reverse Signal
D	25T-B	Neutral Signal

**CONNECTOR TS2 - TRANSMISSION SHIFTER**

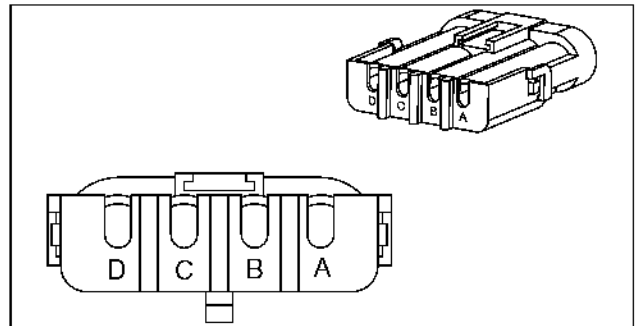

245487C1

CAV	WIRE IDENT	CIRCUIT
A		Not Used
B	25W	3rd and 4th Gear Signal
C	25Z	1st and 4th Gear Signal
D	25Y	Transmission Kick Down Signal

# Section 4003

4003

## BATTERIES

## INSTRUMENT CLUSTER

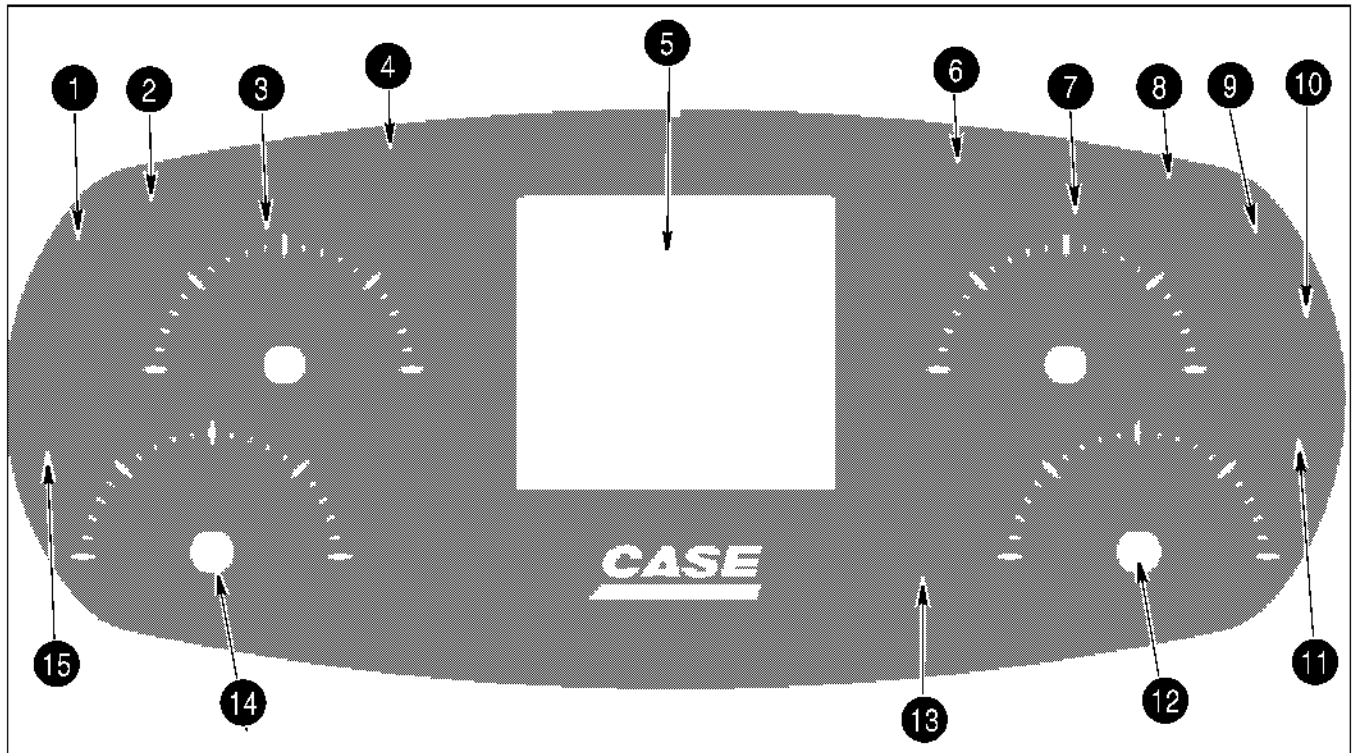

BD06H039

- |                                       |  |
|---------------------------------------|--|
| 1. LOW BRAKE PRESSURE INDICATOR       | 9. LACK OF AUX STEER PRESSURE (OPTIONAL) |
| 2. HIGH BEAM INDICATOR                | 10. PARKING BRAKE INDICATOR              |
| 3. TRANSMISSION OIL TEMPERATURE GAUGE | 11. RIGHT TURN INDICATOR                 |
| 4. CAUTION MASTER INDICATOR           | 12. FUEL LEVEL GAUGE                     |
| 5. MULTI FUNCTION LCD DISPLAY         | 13. FUEL LEVEL AT MINIMUM                |
| 6. STOP MASTER INDICATOR              | 14. ENGINE COOLANT TEMPERATURE GAUGE     |
| 7. HYDRAULIC OIL TEMPERATURE GAUGE    | 15. LEFT TURN INDICATOR                  |
| 8. WAIT TO START ENGINE PREHEAT       |  |

The instrument cluster monitors a number of functions and can be tailored to fit the operator's preferences. The instrument cluster not only monitors machine functions, it warns the operator when caution is needed due to a possible malfunction and when immediate action is needed due to a possible critical malfunction. When the machine is started, the instrument cluster will perform the following self-test:

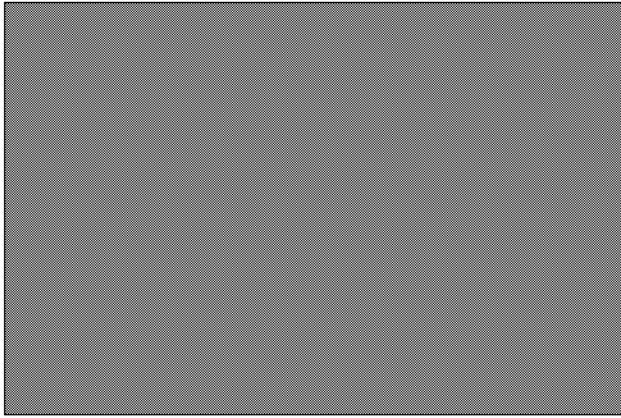

BD06F174

## Options Menu

Use the arrow keys to choose the options menu. Press the confirm key, and the options sub-menu will appear. The options menu will allow the operator to choose options for the fan, idle.

### Fan Auto

The fan can be set to run at automatic or the fan will run at maximum speed. Automatic is the more common or preferred setting. It will change speeds and reverse as conditions require depending on actual temperature of the coolant, turbocharger air, transmission oil, and hydraulic oil.

The operator can choose fan speed or reversing capabilities. Highlight the fan auto selection by using the arrow keys and then press confirm. When you have chosen the selection, lock the selection into memory by pressing the confirm key.

## Auto Idle

Idling can be changed from automatic to a fixed rate. The fixed idle rate is defined as Standard Idle at 900 RPM. Highlight the auto idle selection by using the arrow keys, then press confirm. When you have chosen the selection, lock the selection into memory by pressing the confirm key.

## Display Menu

The display menu can be used to change the background and brightness of the screen. Use the arrow keys to make your selection from the display menu and press the confirm key to lock the selection into memory. The screen display can be changed to suit working conditions for day and night separately.

## RPM

Engine speed in RPM will show on the display if the engine speed is running up to 550 RPM's, and will disappear if the engine speed is lower than 300 RPM.

## MPH/KPH

Vehicle speed will show on the display if it is up to 1.0 MPH / 1.5 KPH and will disappear if the vehicle speed is less than 0.6 MPH / 1.0 KPH.

CODE	DEFINITION	DESCRIPTION AND POSSIBLE STEPS FOR REPAIR
3141	Set point of fuel volume flow through metering unit is lower than calculated limit	High pressure system: Rail pressure sensor inaccurate, high pressure pump defective. Low pressure system: Metering unit reflux too low. Check for defects according to failure list.
3147	Oil temperature sensor signal above normal range	Check oil temperature sensor for accuracy and check oil system.
3154	Grid heater relay short-circuit to battery	Short circuit of wiring to external source or inside relay. Check wiring or replace relay
3155	Grid heater relay short-circuit to ground	Short circuit of wiring to ground or inside relay. Check wiring or replace relay
3156	Grid heater relay no load	Broken or disconnected wiring or defective relay. Check wiring or replace relay
3161	Fan actuator signal low	No information available at time of print.
3171	Fuel rail/system pressure - too low	High pressure side: Leakage in high pressure section, injection nozzle stuck in open position, worn high pressure pump, worn injector, leaking pressure relieve valve Low pressure side: Pressure before gear pump too low, gear pump output too low (fuel filter clogged, leakage in low pressure side).
3172	Fuel rail/system pressure - too high	Metering unit stuck in open position, zero-delivery throttle clogged, metering unit without power due to electrical error. Low pressure side: Pressure before gear pump too high (e.g. by pressure relieve valve), pressure after zero-delivery throttle too high.
3173	Fuel rail/system pressure - too low	See fault 3171
3174	Fuel rail/system pressure - too high	See fault 3172
3175	Fuel system leak detected – large leak	Leakage in the high pressure section, injection nozzle stuck in open position, worn high pressure pump, worn injector, leaking pressure relieve valve, injector reflux too high.
3176	Fuel delivery exceeded threshold for pressure in overrun mode	High pressure system: Leakage in the high pressure section, injection nozzle stuck in open position, worn or defective high pressure pump, worn injector, leaking pressure relieve valve. Low pressure system: 'Zero delivery' is not active in metering unit (excessive leakage in metering unit). Check for defects according to failure list.

**INSTRUMENT CLUSTER FAULT CODES**

CODE	DEFINITION	DESCRIPTION AND POSSIBLE STEPS FOR REPAIR
9128	CAN timed out during operation	If error is permanent or repeats often, check CAN wiring harness and connections on the CAN bus circuits.
9129	CAN timed out during operation	
9130	CAN timed out during operation	

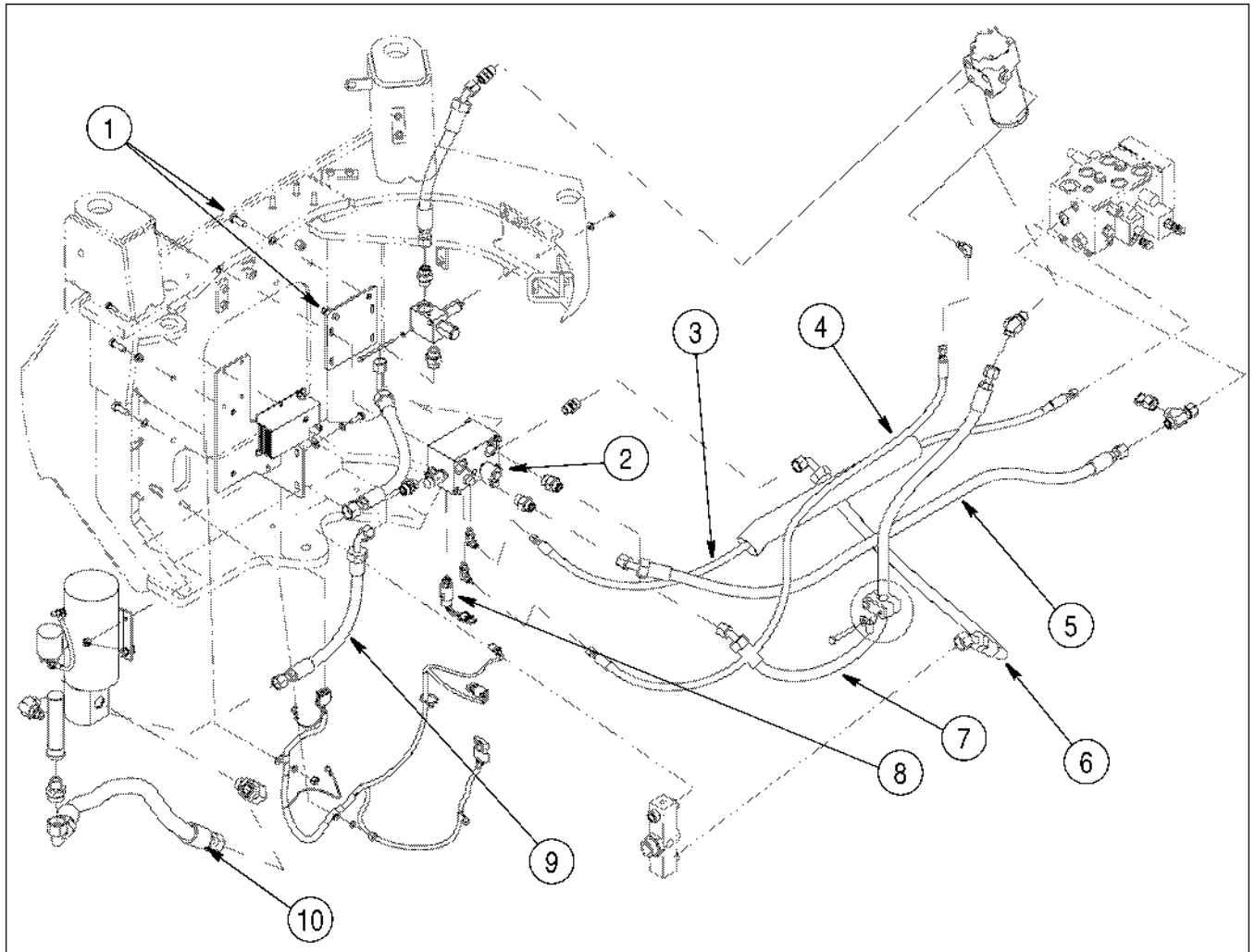

BS07D339

- |   |                           |
|---|---------------------------|
| 1. CAP SCREWS                                   | 6. TANK RETURN TUBE       |
| 2. STEERING SOLENOID                            | 7. STEERING PRESSURE HOSE |
| 3. STEERING LOAD SENSING HOSE TO PRIORITY VALVE | 8. PRESSURE SWITCH        |
| 4. STEERING LOAD SENSING HOSE TO STEERING VALVE | 9. PRESSURE HOSE          |
| 5. PRESSURE HOSE PUMP OUTPUT                    | 10. INLET HOSE TO PUMP    |

**AUXILIARY STEERING PRIORITY VALVE ILLUSTRATION**

## SPECIAL TOOLS

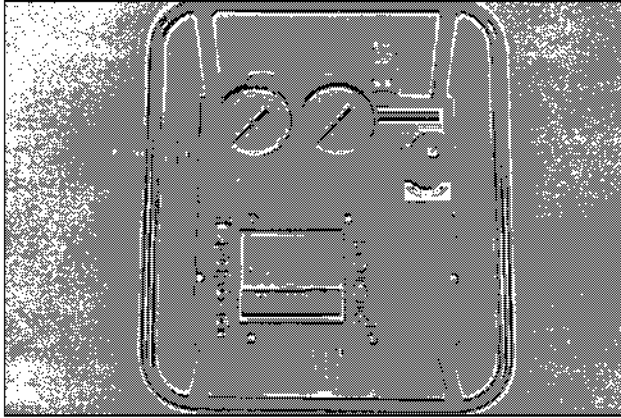

OEM1239 (CAS10280) FLOWMETER

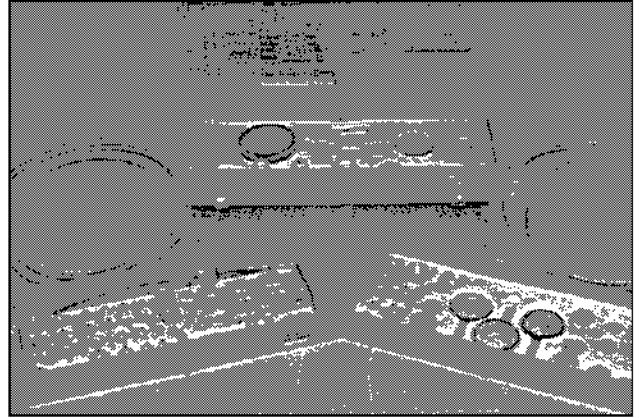

CAS1804 PRESSURE TEST FITTING KIT

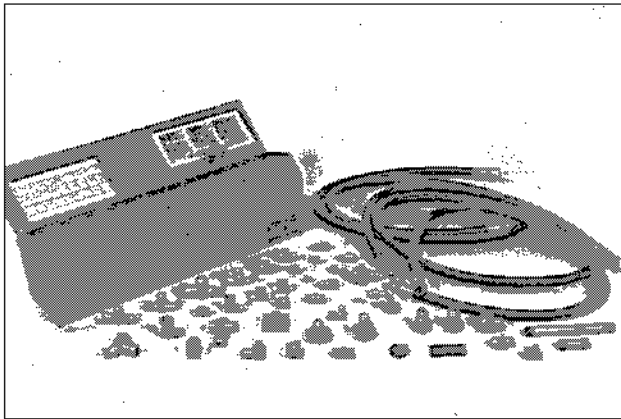

CAS1808 FLOWMETER FITTING KIT

## TROUBLESHOOTING THE STEERING SYSTEM

**NOTE:** *The steering hydraulic schematic is included in the hydraulic schematic. Refer to the rear pocket of this manual.*

1. Make sure the oil level in the hydraulic reservoir is correct. Visually inspect the steering system for leakage and damage.
2. Do the steering relief valve pressure test. Refer to page 7. If the pressure is above or below specifications, adjust the steering relief valve in the loader control valve.
3. Do the main hydraulic pump test. See Section 8002. If the main pump is bad, repair or replace the main hydraulic pump.
4. Test the steering cylinders for leakage, refer to instructions on page 10. If a steering cylinder is leaking, repair or replace the steering cylinder.

## SPECIFICATIONS

Torque for piston cap screw ..... 810 to 925 Nm (597.5 to 682 pound feet)  
 Torque for gland ..... 339 to 475 Nm (250 to 350 pound feet)

## STEERING CYLINDER

### Disassembly

1. Fasten tube (1) in a vise. Be careful not to damage the tube. See illustration on page 4.
2. Remove gland (6) from tube (1).
3. Pull piston rod (19) and piston (17) straight out of tube (1).
4. Fasten piston rod (19) yoke in vise and put a support below piston rod near piston (17). Put a shop cloth between support and piston rod to prevent damage to piston rod.
5. Loosen and remove bolt and washer (18) that mounts the piston (17) to the piston rod (19).
6. Remove piston (17) from piston rod (19).
7. Remove and discard seal (13), loader ring (15), wear ring (14), and cast iron ring (16) from piston (17).
8. Remove gland (6) from piston rod (19).
9. Remove and discard O-ring (8), backup ring (9), O-ring (7), rod wiper (5), rod seal (10), buffer seal (11), and bearing (12) from gland (6).

### Inspection

1. Clean all parts in cleaning solvent.
2. Check to be sure that piston rod (19) is straight. If piston rod is bent, install a new piston rod.
3. Inspect inside of tube (1) for deep grooves and other damage. If there is any damage to tube, a new tube must be used.
4. Remove small scratches on piston rod (19) or inside tube (1) with emery cloth of medium grit. Use emery cloth with a rotary motion.
5. Inspect bushing (3). If bushing requires replacement, remove grease fitting (4) and retaining rings (2) then press bushing from tube end.

9. Put the bearing retainer (7) in place on the upper pivot bearing (9), refer to Figure 1.
10. Install the bearing driver and plate, refer to Figure 4.
11. Tighten a nut on the screw until the bearing retainer (7) is tight against the upper pivot bearing (9).

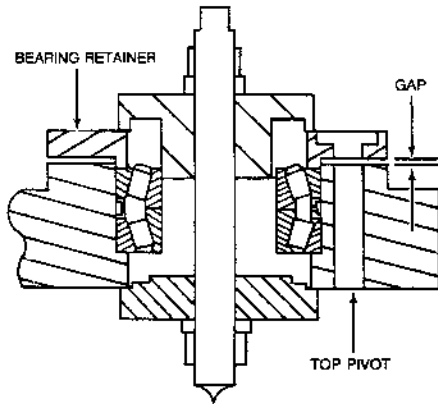

FIGURE 4.

B1425A88J

12. Measure the gap between the bearing retainer (7) and the top pivot. Make a record of the measurement. Subtract 0.0762 to 0.1016 mm (0.003 to 0.004 inch) from the measurement, refer to Figure 4. Select shims (8) equal to that value.
13. Remove the bearing driver, plate, and bearing retainer (7) from the top pivot.
14. Install the shims (8) and the bearing retainer (7).
15. Install the washers (2) and bolts (1). Tighten the bolts (1) to 124 Nm (92 pound-feet).
16. Install the seal (6) in the bearing retainer (7). The top of the seal (6) must be even with the top of the bearing retainer (7), refer to Figure 5.

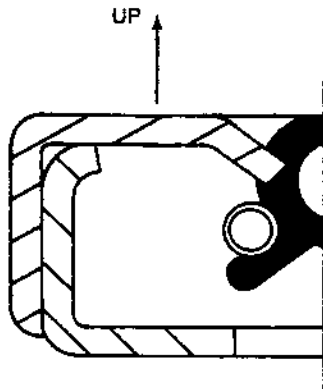

FIGURE 5.

B1426A88J

17. Fill the other seal (6) for the top pivot with grease. See Specifications in this section for the correct grease.
18. Use an acceptable driver to install the seal (6) in the bottom of the top pivot, refer to Figure 6.
19. The bottom of the seal (6) must be even with the bottom of the top pivot.

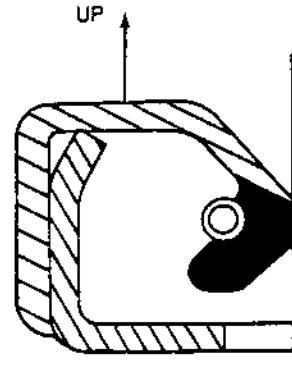

FIGURE 6.

B1430A88J

20. Apply grease to the upper pivot pin (4).
21. Install the upper pivot pin (4) in the top pivot.
22. Lubricate the top pivot until grease is forced out of the seal (6). See Specifications in this section.
23. Rotate the upper pivot pin (4) to check the bearing assembly. The upper pivot pin (4) must rotate smoothly, but not easily. Leave the upper pivot pin (4) in place to keep dirt out of the upper pivot bearing (9).
24. Lubricate the bore for the bottom pivot with grease. Install a bearing cup in the bottom pivot.
25. Install the bearing driver and plate, refer to Figure 7.

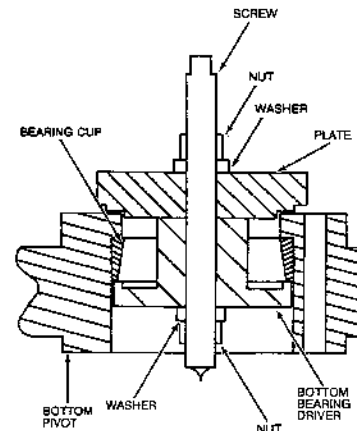

FIGURE 7.

B1427A88J

# Section 5009

## JOYSTICK STEERING SYSTEM (JSS) (optional)

## ELECTRICAL SYSTEM

### Removal

#### STEP 1

Park loader on firm, level surface and lower bucket to ground. Put transmission in NEUTRAL, apply parking brake, and shut down engine. Put the master disconnect switch in the OFF position.

#### STEP 2

Remove all dirt and grease from the steering system valves and adjacent area.

**NOTICE:** MARK and LABEL all the various parts (electric connections, hydraulic connections, etc.) prior to disassembly.

#### STEP 3

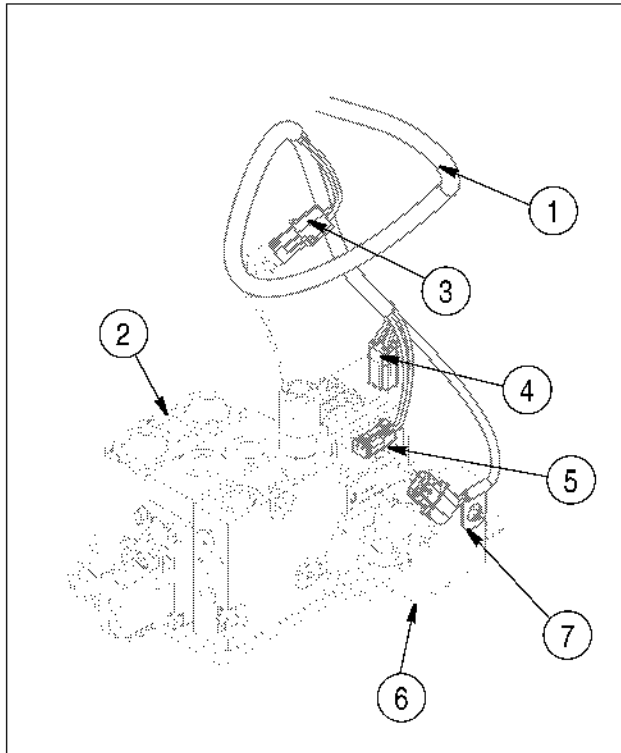

W130R0003

Disconnect the cable (1) from valve PVG32 (2). Disconnect connector (3) from the pilot pressure switch, connector (4) of the proportional valve, connector (5) from the solenoid valve. Remove cap screws (7) and washers from PVFC (6).

#### STEP 4

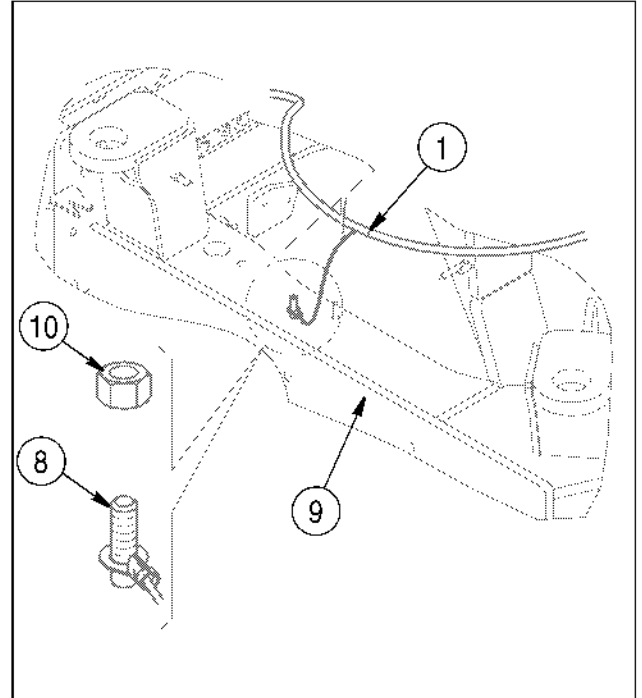

W190-4R072

Remove nut (10) from stud (8) to release the chassis grounding cable (1) from the rear chassis frame (9).

**STEP 5**

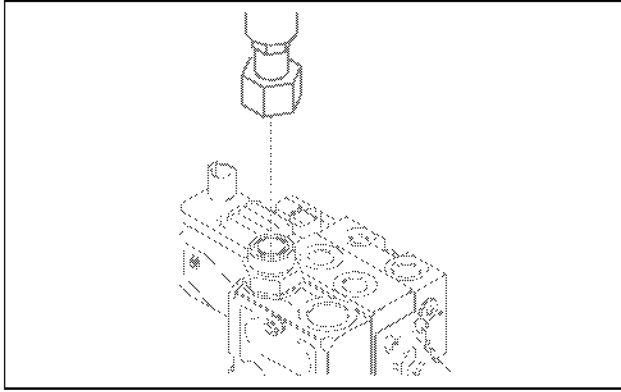

W130R0008

Tag and disconnect the flexible outlet hose.

**STEP 6**

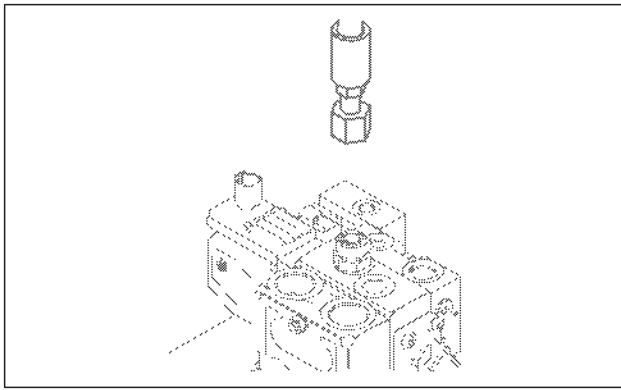

W130R0009

Tag and disconnect the steering cylinder supply hose.

**STEP 7**

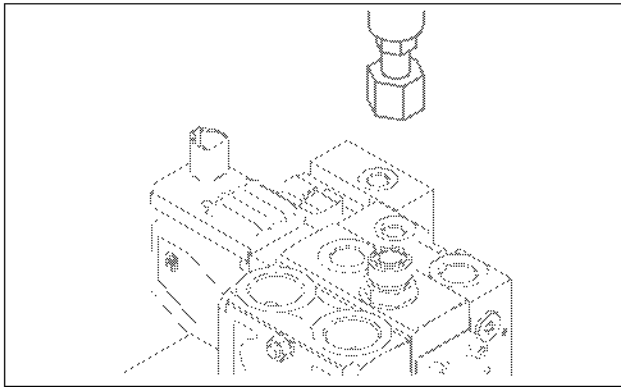

W130R0010

Tag and disconnect the supply hose of stem side steering cylinder line.

**STEP 8**

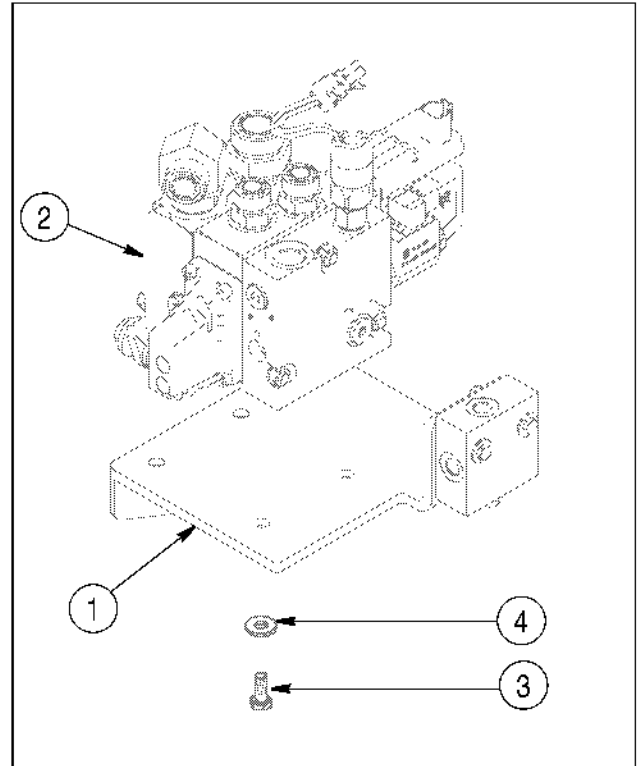

W130R0011

Remove the steering valve PVG32 (2) from the support (1) by removing four mounting screws (3) and washers (4).

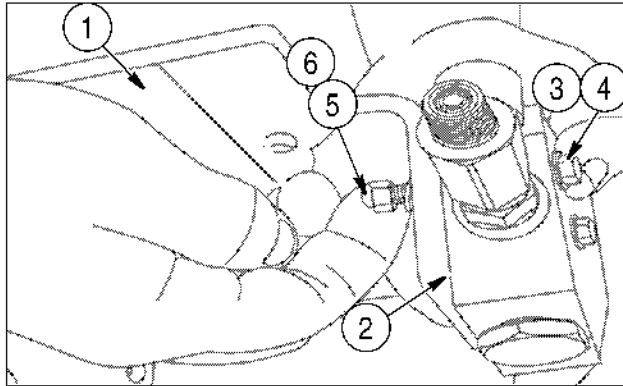
**STEP 28**

W190-4R028

Install the valve PVFC (2) on the support (1) with the two screws (3) and washers (4), the nuts (5) and washers (6).

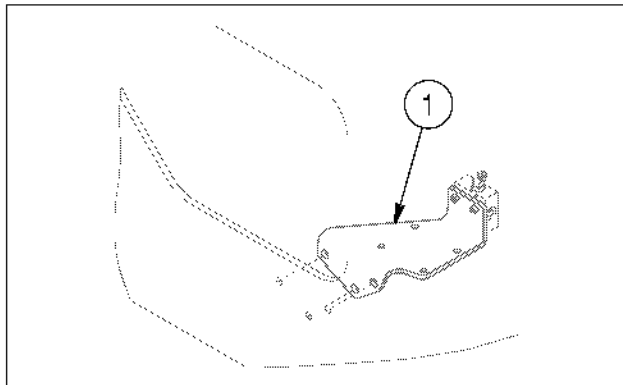
**STEP 29**

W130R0013

Position the support (1) of the steering valves on the right-hand side of the rear chassis frame

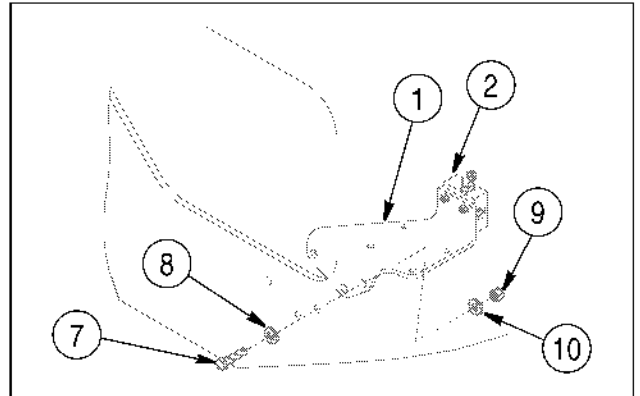
**STEP 30**

W130R0026

Install the valve support (1) on the side wall of the rear chassis frame with three screws (7) and washers (8). Tighten the screws to a torque of 110 Nm (81 pound feet).

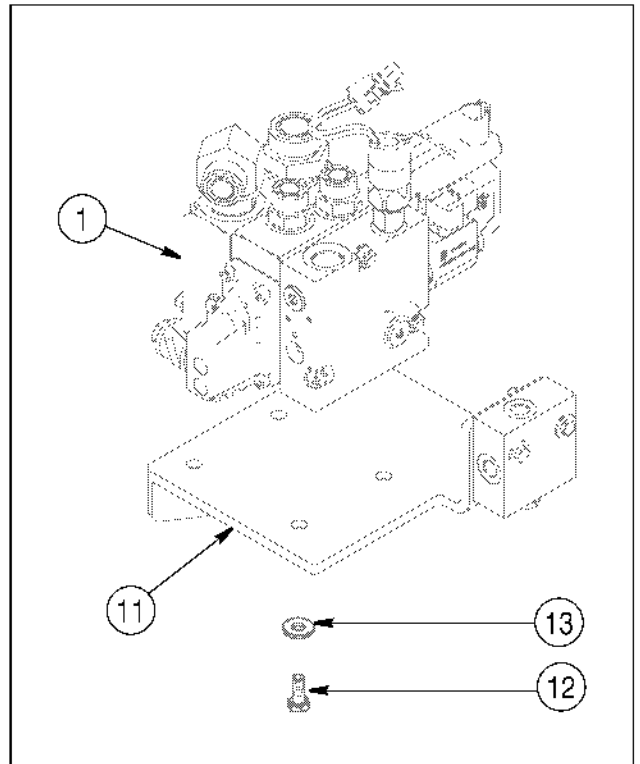
**STEP 31**

W130R0027

Install the valve PVG32 (1) on the support (11) using the four screws (12) and washers (13). Torque the screws to 30 Nm (22 pound feet).

## Installation

### STEP 24

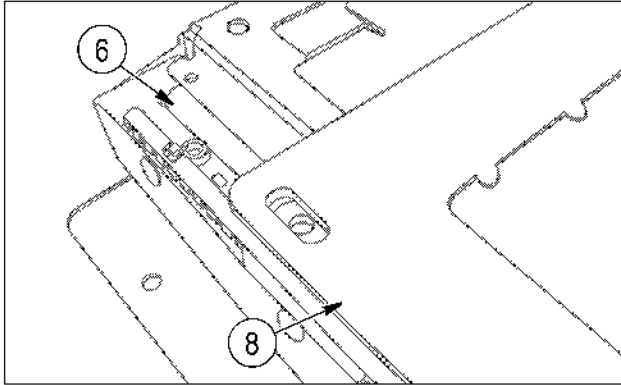

W190-4R054

Position the armrest support plate (8) on the seat runners (6).

### STEP 25

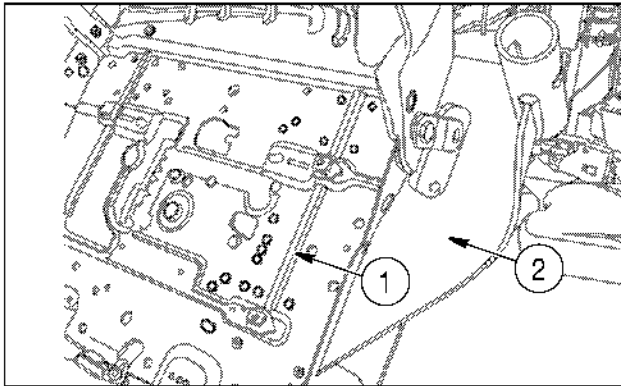

W190-4R055

Position the seat plate (1) on the seat support plate (2).

### STEP 26

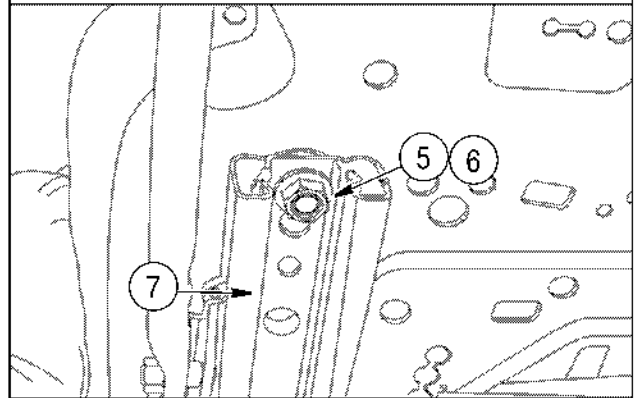
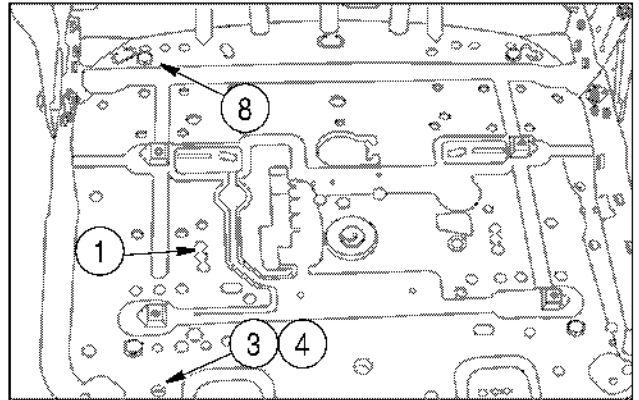

W190-4R056

Push the seat plate (1) forward. From the top, insert the two front capscrews (3) and washers (4). From the seat runners (7), install the nuts (5) and the washers (6). Tighten the nuts to a torque of 32 Nm (24 pound feet). Repeat the procedure for the two rear capscrews (8).

**STEP 6**

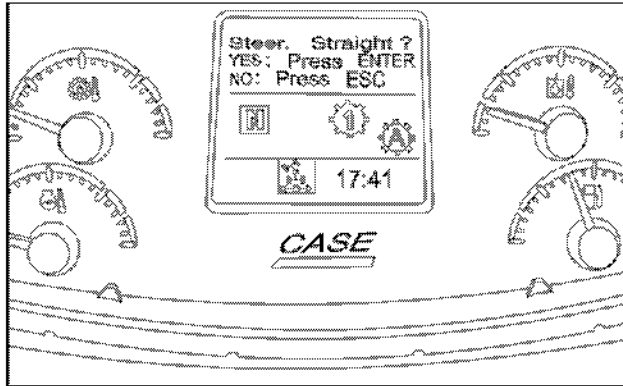

521E-4R007

The display will show a screen with the wording **"Steer. Straight?"** Press the enter button to confirm the operation.

**STEP 7**

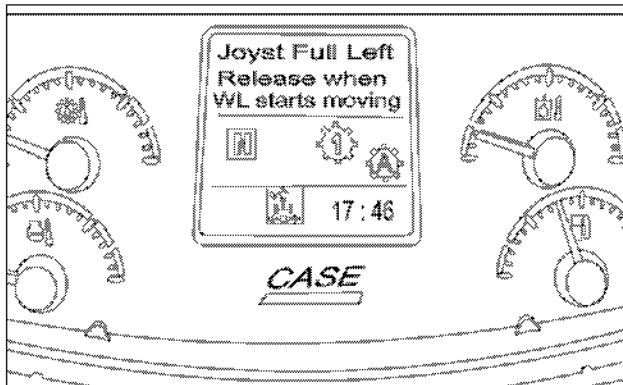

521E-4R008

The display will read **"Joyst Full Left" "Release when WL starts moving"**. Move the Joystick lever completely to the left. As soon as movement is noticed, release the lever.

**STEP 8**

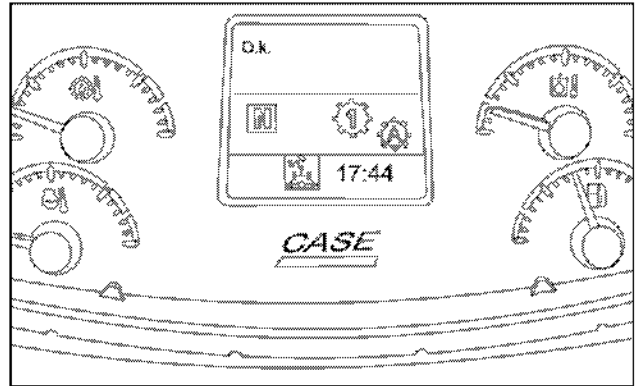

521E-4R009

After this operation, the display will read **"O. K."** The display will automatically read **"Joyst Full Left" "Release when WL starts moving"**. Move the joystick lever completely to the left. As soon as machine movement is noticed, release the lever.

**STEP 9**

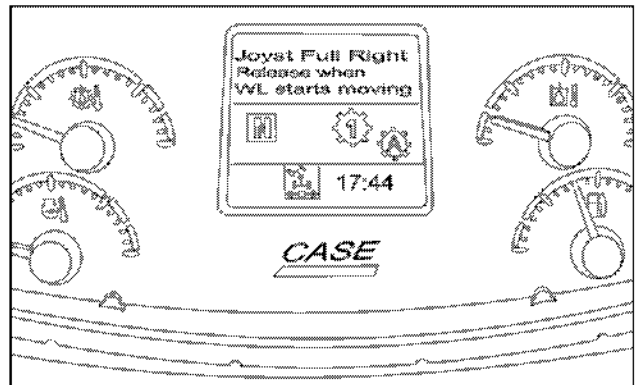

521E-4R010

The display will then automatically show the screen with the wording **"Joyst Full Right" "Release when WL starts moving"**. Move the Joystick lever completely to the right. As soon as machine movement is noticed, release the lever.

# Transmission Mounting

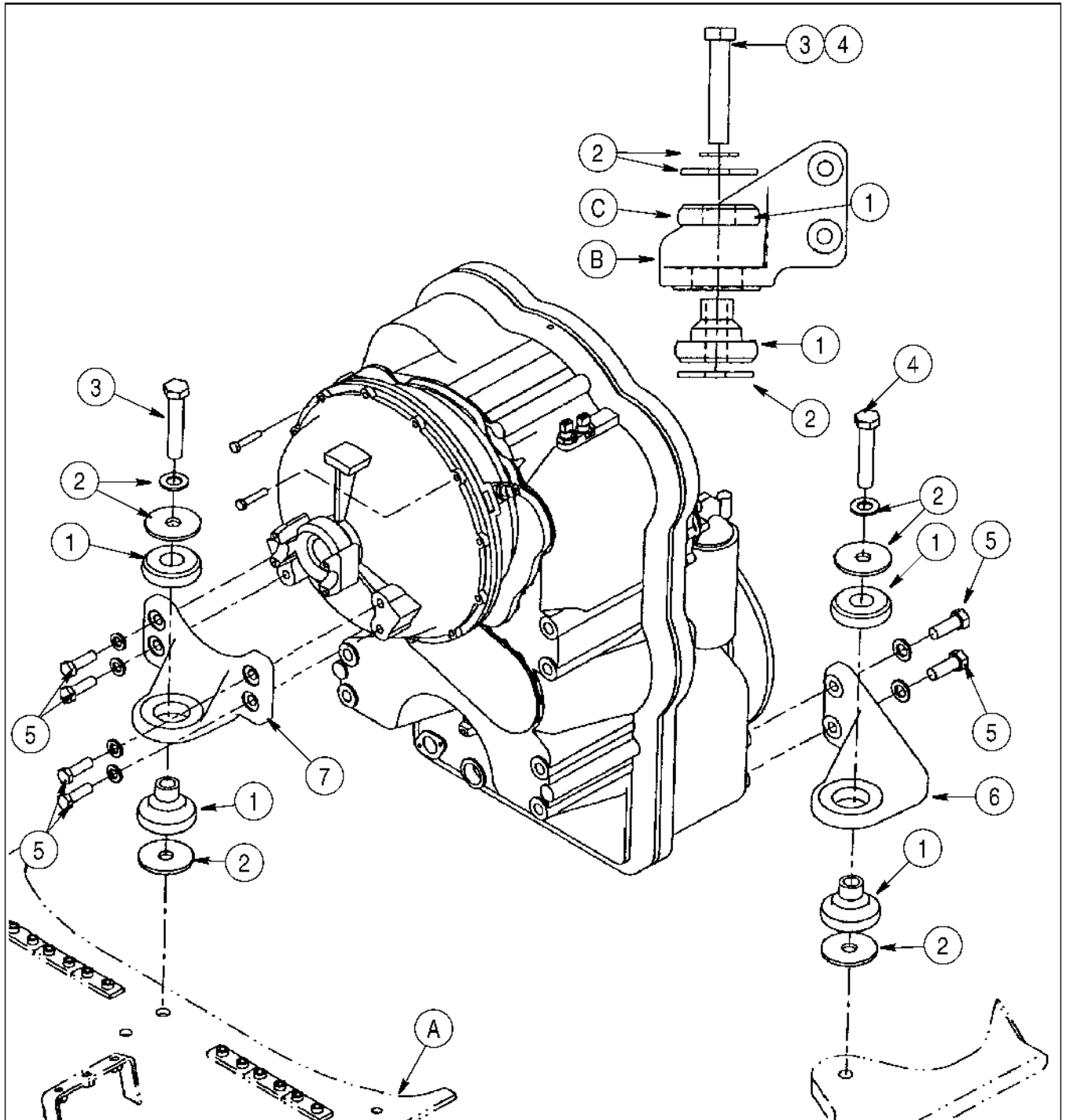

BS03B153

- |                  |                          |
|------------------|--------------------------|
| 1. ISOLATOR BOLT | 6. MOUNTING BRACKET      |
| 2. WASHER        | 7. TOP MOUNTING BRACKET  |
| 3. BOLT          | A. REAR CHASSIS TRUNNION |
| 4. BOLT          | B. BRACKET (6 OR 7)      |
| 5. BOLT          | C. SMALLER PIECE ON TOP  |

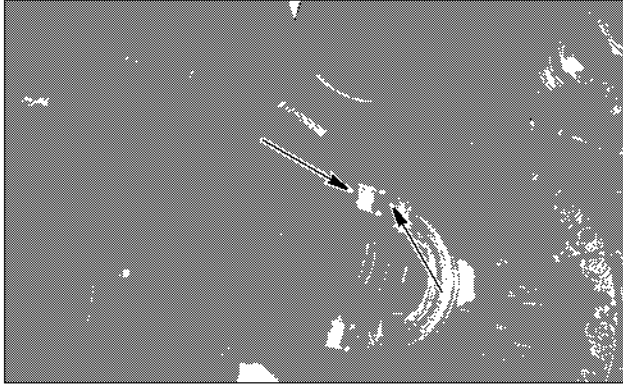
**STEP 21**

Secure drive shaft to front axle using two straps and four bolts. Tighten bolts to a torque of 75 to 81 Nm (50 to 60 pound feet).

**STEP 22**

If necessary, fill axle with gear lubricant specified in Section 1002.

**STEP 23**

Refer to Section 7002 and bleed brakes.

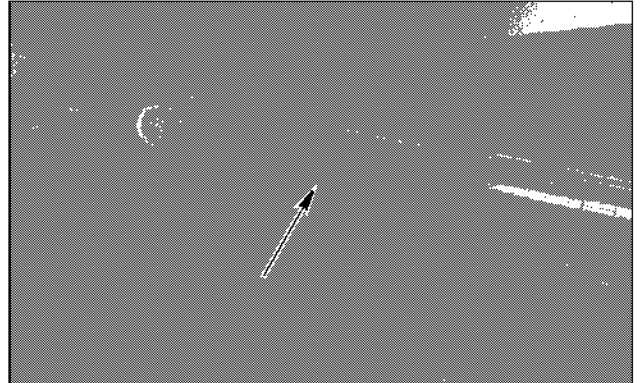
**STEP 24**

Start engine and raise bucket. Have assistant remove safety link. Lower bucket to ground and stop engine.

**STEP 25**

Put articulation lock in OPERATING position.

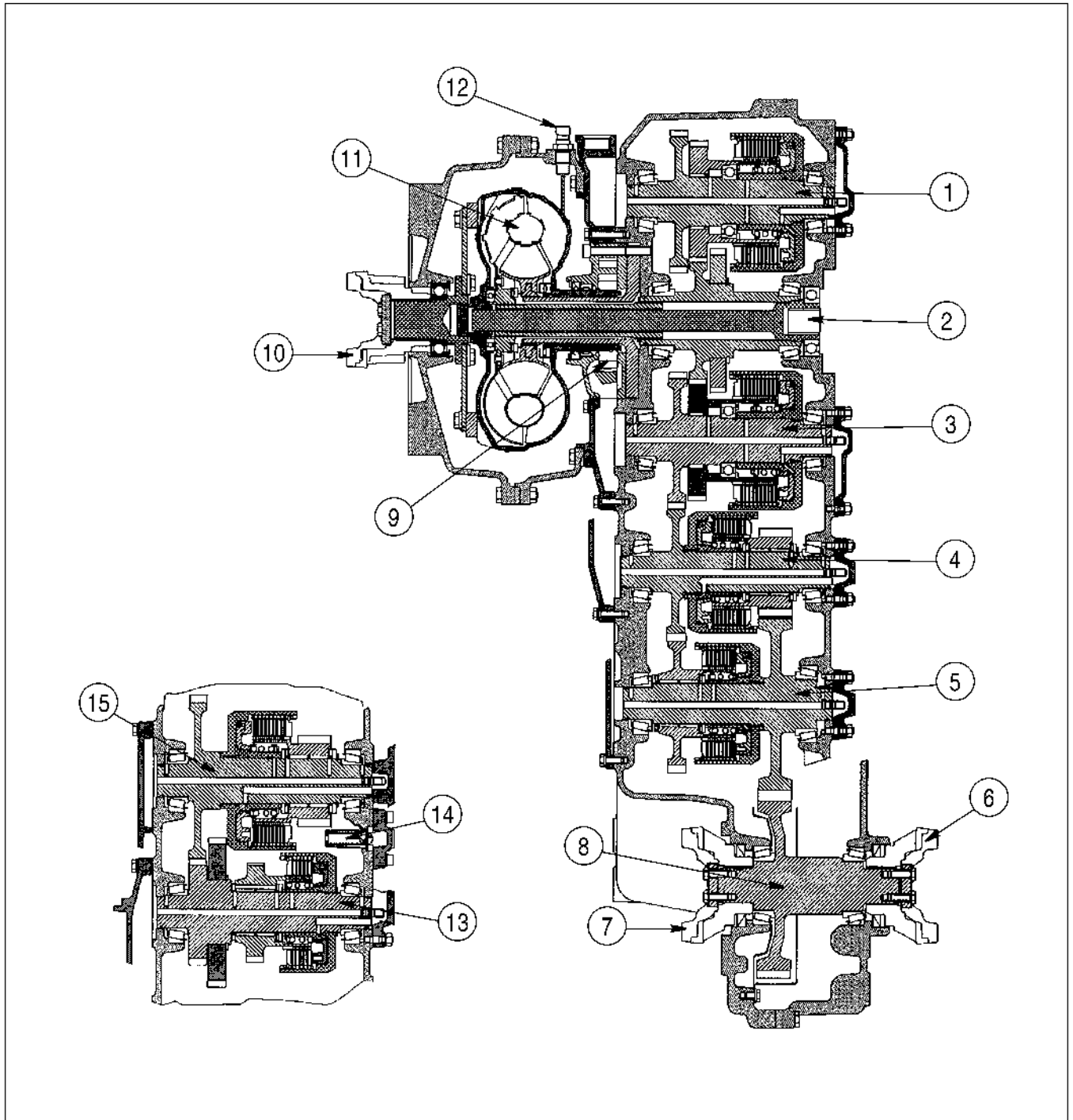

BS03A262

- |                                 |  |
|---------------------------------|--|
| 1. CLUTCH SHAFT KR              | 9. TRANSMISSION PUMP                       |
| 2. POWER TAKE OFF               | 10. INPUT FLANGE                           |
| 3. CLUTCH SHAFT KV              | 11. CONVERTER                              |
| 4. CLUTCH SHAFT K2              | 12. INDUCTIVE TRANSMITTER FOR ENGINE SPEED |
| 5. CLUTCH SHAFT K3              | 13. CLUTCH SHAFT K4                        |
| 6. OUTPUT FLANGE REAR           | 14. CONVERTER RELIEF VALVE                 |
| 7. OUTPUT FLANGE CONVERTER SIDE | 15. CLUTCH SHAFT K1                        |
| 8. OUTPUT SHAFT                 |  |

COMPONENT LOCATIONS TRANSMISSION LAYOUT

## CHART FOR RECORDING PRESSURE READINGS

Use this chart to record the pressure readings.

P.I.N. Number:								Date:		
TEST POINTS										
Shift Speed	P 65	V 53	R 55	1 56	2 57	3 58	4 60	5 51	6 52	LP
1st F										
2nd F										
3rd F										
4th F										
1st R										
2nd R										
3rd R										
Neut										

P= MAIN PRESSURE      1= FIRST GEAR CLUTCH      4= FOURTH GEAR CLUTCH      LP= LUBE PRESSURE  
 V= FORWARD CLUTCH      2= SECOND GEAR CLUTCH      5= CONVERTER IN  
 R= REVERSE CLUTCH      3= THIRD GEAR CLUTCH      6= CONVERTER OUT

## DISASSEMBLY

### STEP 1

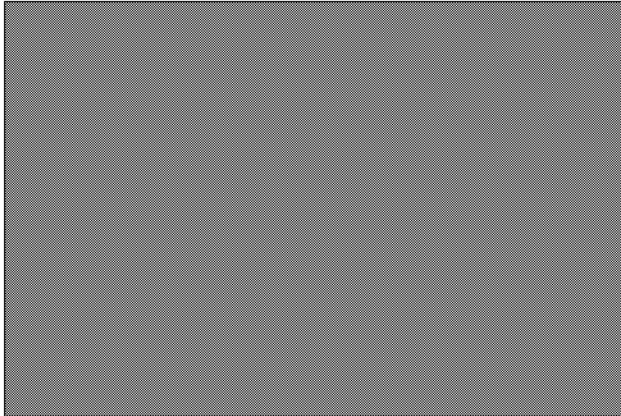

GD98M833

Fasten transmission on an assembly stand using CAS2801 transmission mounting brackets.

### STEP 2



GD98M835

Remove and discard oil filter.

### STEP 3



GD98M836

Remove hex head screws securing filter head. Remove filter head from transmission.

### STEP 4

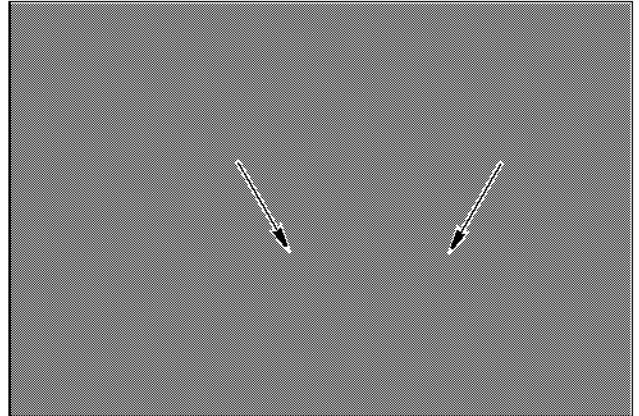

GD98M837

Remove two socket head screws and install CAS2885 transmission valve adjustment tool set. Remove remaining 21 socket head screws securing control valve. Loosen and remove hex rods (part of CAS2885) from studs then remove control valve.

### STEP 5



GD98M838

Remove both gaskets and the intermediate plate.

### STEP 6



GD98M839

Remove socket head screws and hex nuts. Remove duct plate. Remove flat gasket.

CLICK HERE TO **DOWNLOAD** THE COMPLETE MANUAL

- Thank you very much for reading the preview of the manual.
- You can download the complete manual from: [www.heydownloads.com](http://www.heydownloads.com) by clicking the link below



- Please note: If there is no response to **CLICKING** the link, please download this PDF first and then click on it.

CLICK HERE TO **DOWNLOAD** THE COMPLETE MANUAL

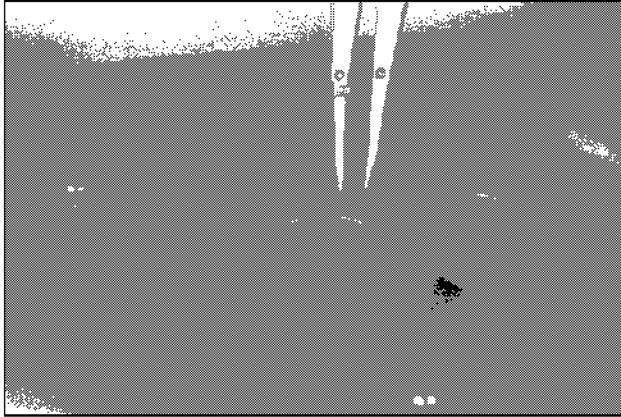
**STEP 62**

BK00D020

Remove the snap ring.

**STEP 63**

BK00D019

Remove the compression spring.

**NOTE:** The following two steps are for disassembly of the input shaft.

**NOTE:** A snap ring is used to lock turbine shaft in input shaft. Snap ring will be destroyed when turbine shaft is pressed from input shaft.

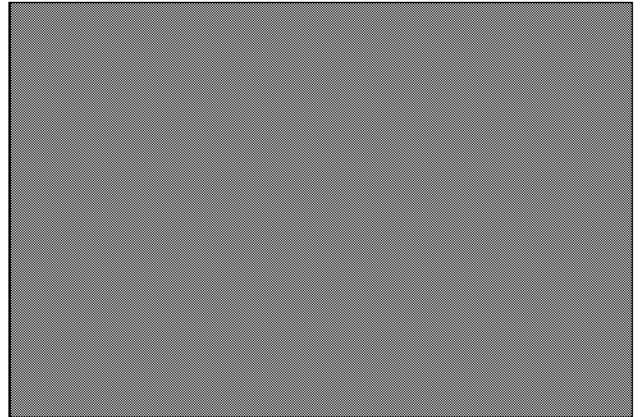
**STEP 64**

GD98M803

If turbine shaft is to be removed from input shaft, use proper size diameter sleeve or rod and press turbine shaft out of input shaft.

**STEP 65**

Remove bearings from input shaft using a bearing puller.

**NOTE:** The following steps are for assembly of clutch K4.

### STEP 114

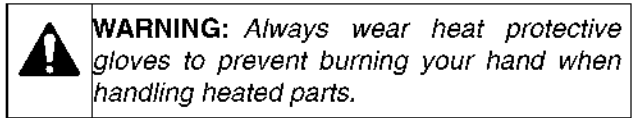

SM121A



GD98M647

Heat the gear to about 120° C (248° F) and install until seated in position.

### STEP 115

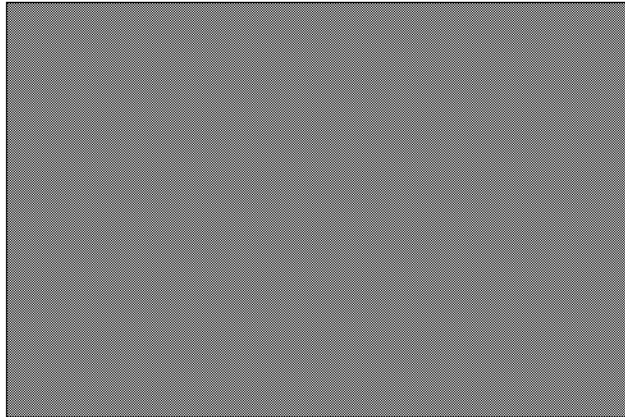

GD98M648

Install retaining ring to secure gear.

### STEP 116

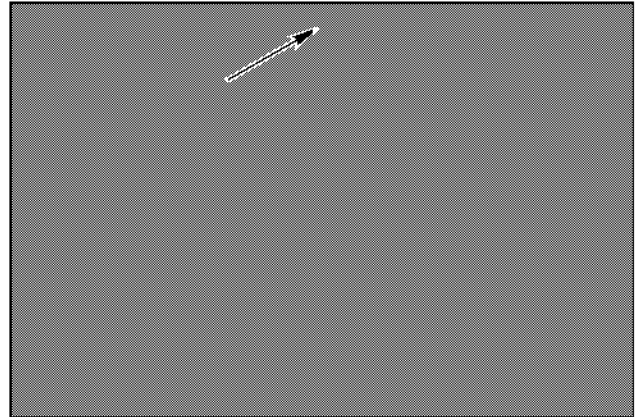

GD98M649

Apply Loctite 243 to the stud and install the stud. Tighten the stud to a torque of 17 Nm (150 pound inches).

### STEP 117

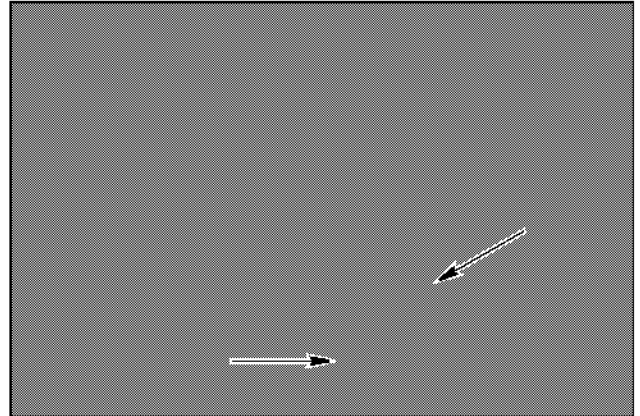

GD98M650

Check that drain hole is clear and free of foreign matter. Install both O-rings in recesses of the piston and apply oil.

### STEP 118



GD98M651

Install piston in clutch disc carrier. Be sure piston bottoms out.

**STEP 171**

GD98M709

Install the oil feed housing with the hex head screws and flat washers. Tighten the screws to a torque of 25 Nm (221 pound inches).

**STEP 172**

GD98M711

Position the gasket and cover. Secure the cover with the hex head screws. Tighten the screws to a torque of 23 Nm (204 pound inches).

**NOTE:** *The following steps are for the assembly of the engine connection and converter.*

**STEP 173**

GD98M712

Position converter housing. Secure with hex head screws. Tighten the screws to a torque of 68 Nm (50 pound feet).

**STEP 174**

GD98M713

Put input shaft in a vise as shown. Position diaphragm on input shaft and secure using 12 hex head screws. Tighten screws to a torque of 115 Nm (85 pound feet).

**STEP 175**

GD98M714

Position diaphragm and input shaft on converter. Apply Loctite 262 to threads of hex head screws. Install screws and tighten to a torque of 115 Nm (85 pound feet).

## WHEEL END AND BRAKE

### Disassembly

**NOTE:** Tools and axle shown in the following photographs may appear slightly different than the tools and axle you may have. The use of the tools and disassembly/assembly of axle is the same regardless of appearance.

#### STEP 1

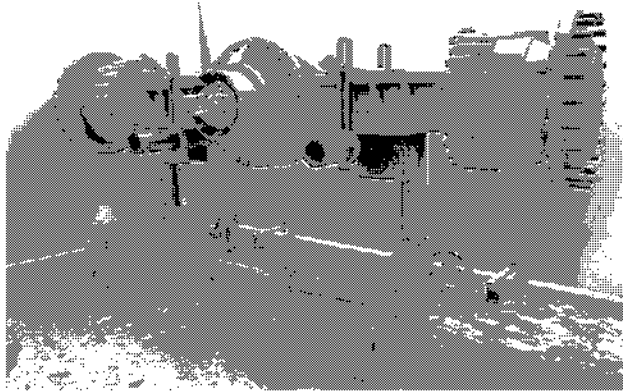

BD00M235

Fasten axle on a stand.

#### STEP 2



BD00M236

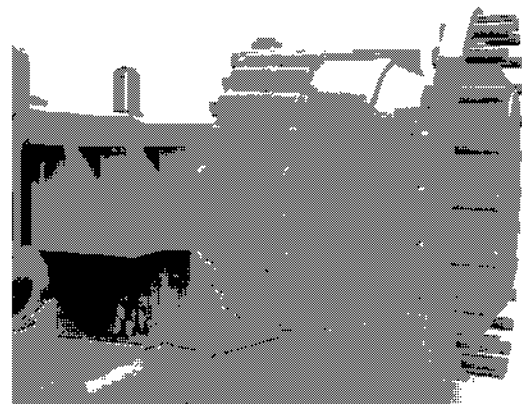

BD00M237

Remove drain plugs and drain oil from axle housing.

Bur 6-45240

#### STEP 3

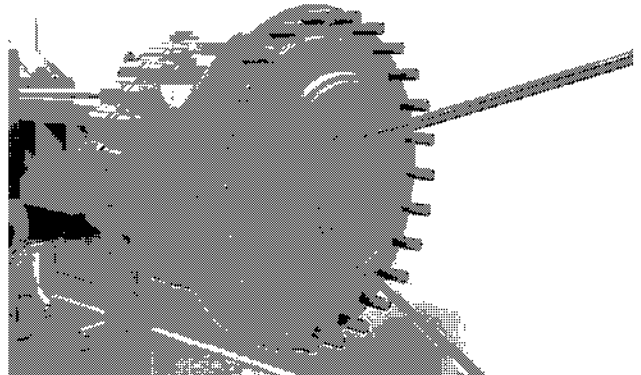

BD00M238

Using two pry bars, remove cover from output shaft. Remove and discard O-ring from cover.

#### STEP 4

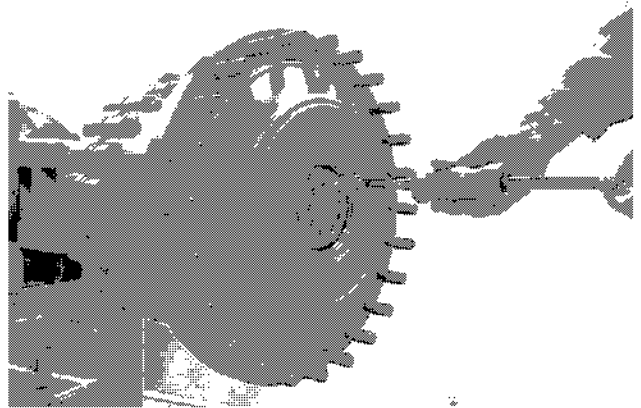

BD00M239

Remove pin from lock nut using OEM4252 slide hammer and CAS10846-3 adapter.

#### STEP 5

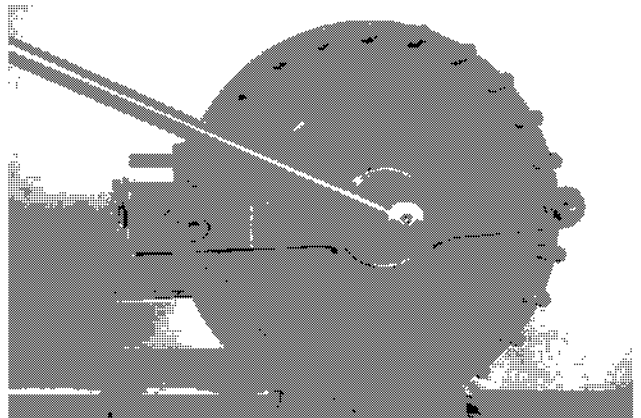

BD00M240

Remove lock nut using CAS2883 support bracket and CAS2876 socket and nuts.

**STEP 53**



BD00M284

Put the assembled pins into the support shim and install the snap ring.

**STEP 54**



BD00M285

Put the assembled support shim in the piston.

**STEP 55**

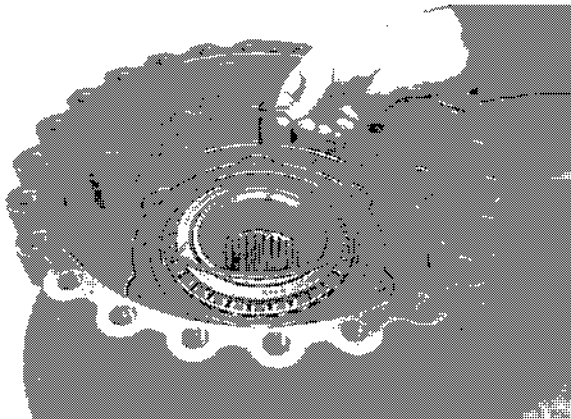

BD00M286

Install the snap ring to secure the support shim.

**STEP 56**

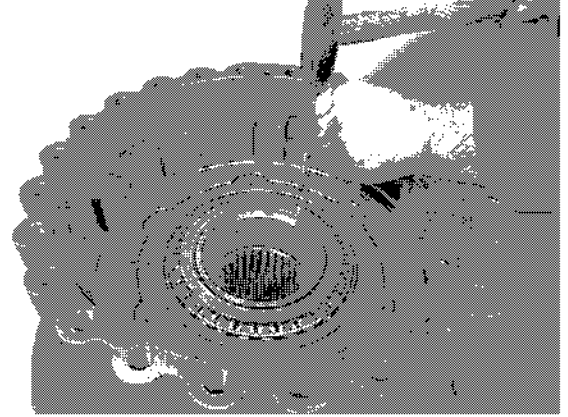

BD00M287

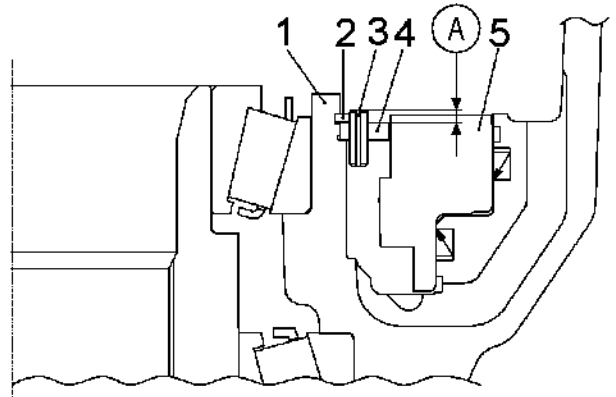

BS00M075

- |                  |                                      |
|------------------|--------------------------------------|
| 1. BRAKE HOUSING | 4. SUPPORT SHIM                      |
| 2. SNAP RING     | 5. PISTON                            |
| 3. PIN           | A. 4.5 TO 5.0 MM (0.18 TO 0.20 INCH) |

Install the three pins (3) in the support shim (4) to lock the snap ring (2). Dimension (A) between top of pins (3) and top of support shim (4) must be 4.5 to 5.0 mm (0.18 to 0.20 inch).

**STEP 57**

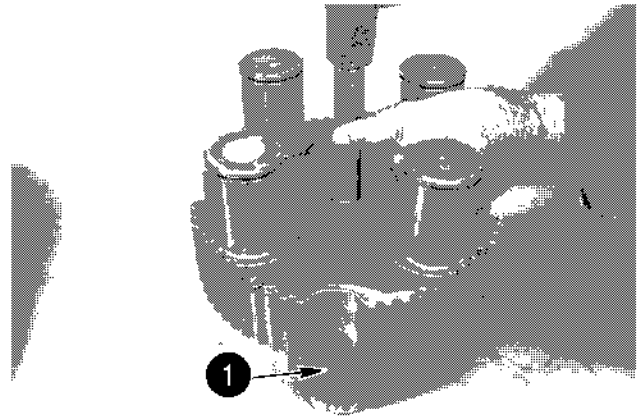

BD00M288

- 1. SPLINE

If removed, drive the stop bolt into the planetary carrier until contact. Then coat the spline with Loctite No. 767 antiseize lubricant.

## DIFFERENTIAL DISASSEMBLY

### STEP 98

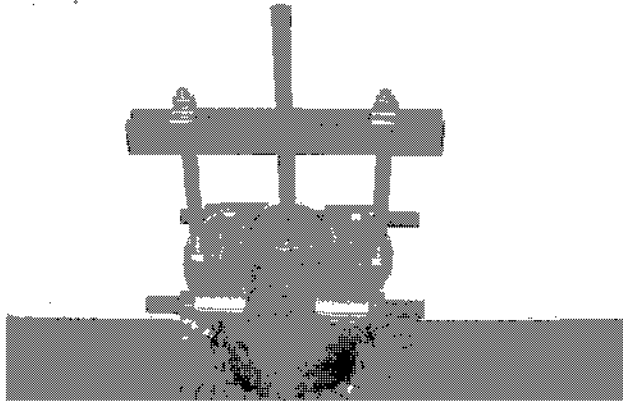

BD01F059

Remove the bearing from the differential housing using CAS2848 puller, OEM4175 pulling attachment, 1103 puller legs, and 8065 step plate.

### STEP 99

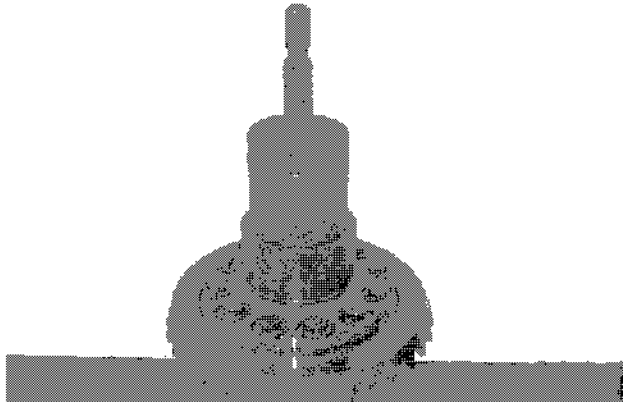

BD01F075

Remove the bearing from the housing cover using CAS2871 collet set, CAS2882 puller body, and 8067 step plate.

### STEP 100

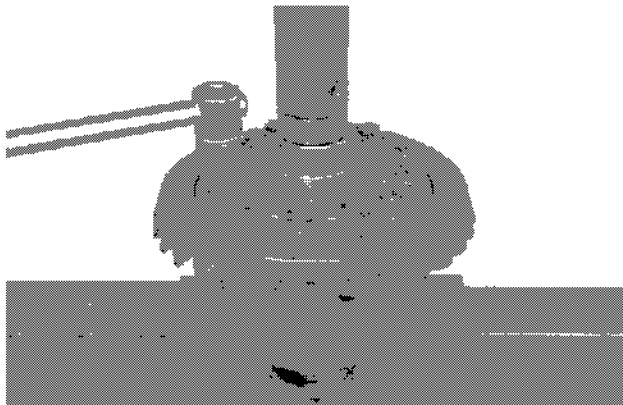

BD00M323

Place the differential in a press to prevent it from turning. Remove the bolts.

### STEP 101



BD00M324

Remove the housing cover from the differential housing.

### STEP 102

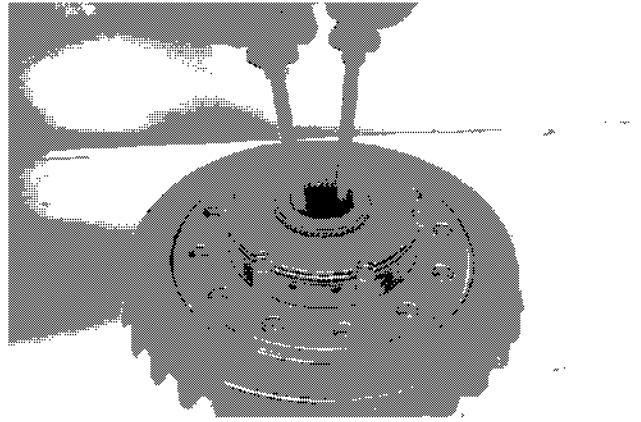

BD00M325

Remove all parts from the differential housing.

### STEP 103

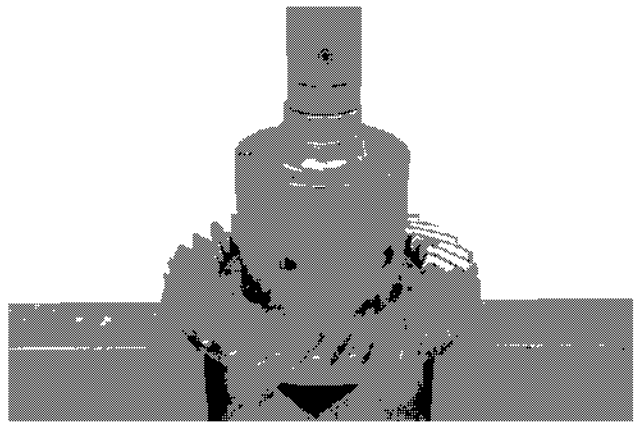

BD00M326

Press the ring gear from the differential housing.

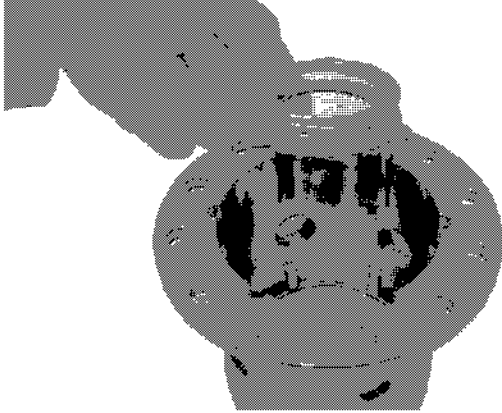
**STEP 148**

BD00M368

Install both thrust washers in the differential housing.

**STEP 149- LIMITED SLIP DIFFERENTIAL**

BD00M369

Starting with an outer clutch disc install alternately the outer and inner clutch discs. Thickness of disc pack must be the same on both sides.

**STEP 150- OPEN DIFFERENTIAL**

Install four outer clutch discs in differential housing. Thickness of disc pack must be the same on both sides.

**STEP 151**

BD00M370

Install the pressure ring in the differential housing.

Bur 6-45240

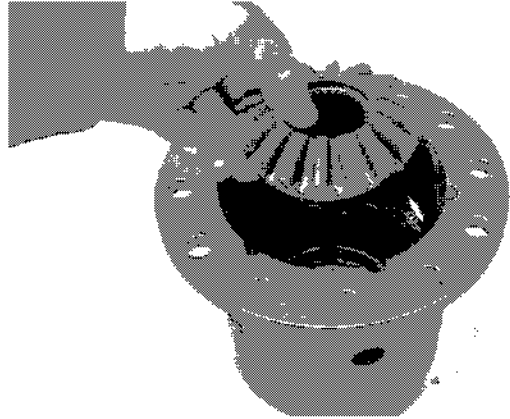
**STEP 152**

BD00M371

Install the axle bevel gear. Make sure axle bevel gear splines mate with splines of all inner clutch discs.

**STEP 153**

BD00M372

Assemble the differential spider and install into the differential housing.

**STEP 154**

BD00M373

Install the second axle bevel gear.

### Pinion Distance Must Be Decreased

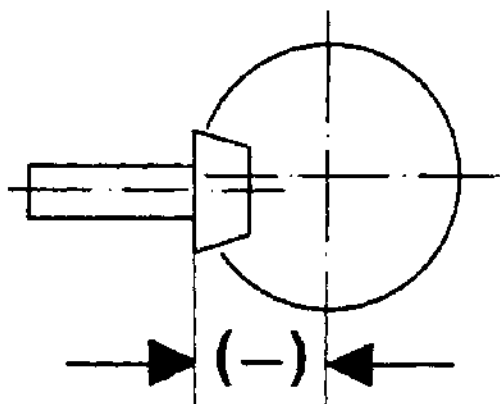

BS01D010



BS01D016

DRIVE SIDE (CONVEX)



BS01D015

COAST SIDE (CONCAVE)

**STEP 47**

**WARNING:** Always wear heat protective gloves to prevent burning your hand when handling heated parts.

SM121A

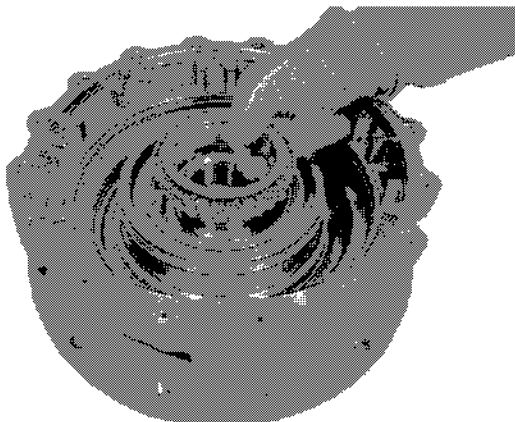

BD02D035

Heat the wheel end shaft inner bearing to 100° C (212° F) in a bearing oven. Wearing heat resistant gloves or mittens, install the bearing on the wheel end shaft until the bearing is against the bearing cup in the brake housing.

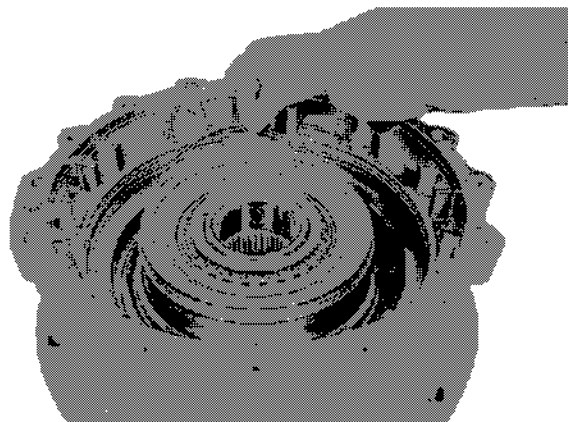
**STEP 48**

BD02D025

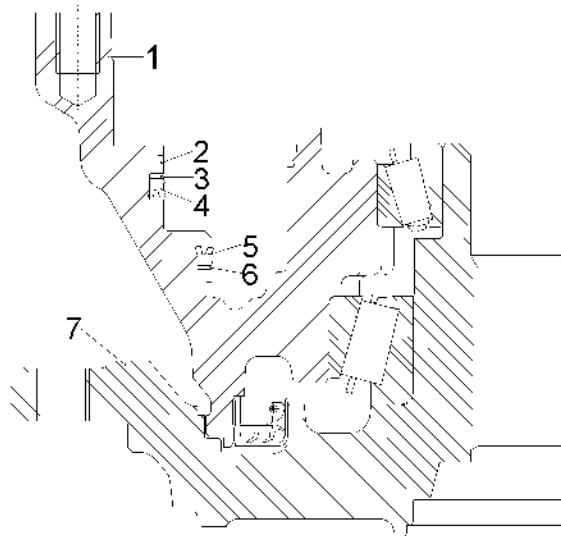

BS02D086

**GUIDE RING, SUPPORT RINGS AND U-RINGS LOCATION**

- |                  |                    |
|------------------|--------------------|
| 1. BRAKE HOUSING | 5. U-RING          |
| 2. GUIDE RING    | 6. SUPPORT RING    |
| 3. SUPPORT RING  | 7. WHEEL END SHAFT |
| 4. U-RING        |                    |

Install the support rings and U-rings in the grooves of the brake housing.

**STEP 87**

BD02D010

Pull the stub shaft out of the sun gear shaft. Be careful not to lose shim(s) that may be installed in sun gear shaft.

**STEP 88**

Do Steps 85 to 87 to remove the other wheel end.

**STEP 89**

BD02D055

Remove 15 bolts securing differential carrier.

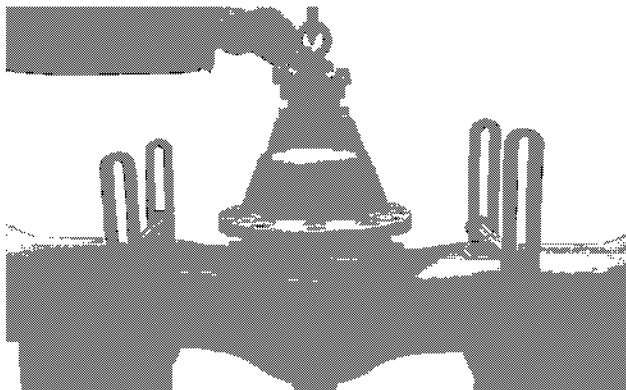
**STEP 90**

BD02D056

Connect lifting equipment to flange and remove the differential carrier from axle housing.

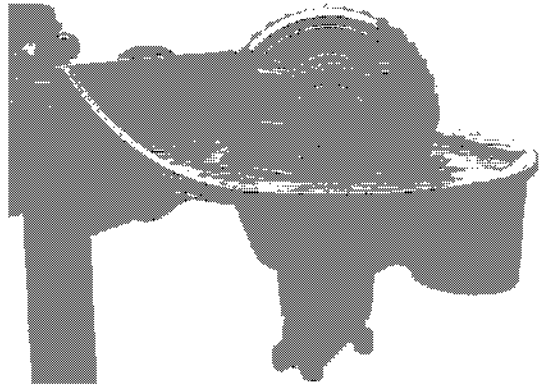
**STEP 91**

BD02D057

Mount differential carrier in OEM4135 engine stand using one CAS2847 holding bracket.

**STEP 92**

BD02D058

Drive out the roll pins from the bearing caps.

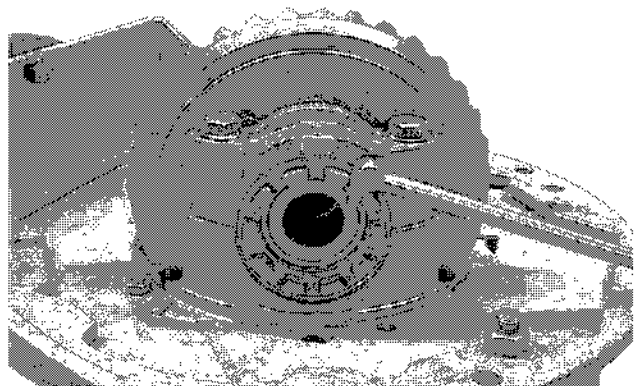
**STEP 93**

BD02F158

Remove both adjusting nuts.

## Drive Pinion Bearing Rolling Torque Adjustment

### STEP 138

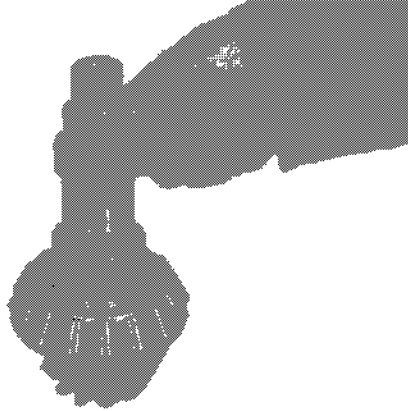

BD02D126

Install an 16.90 mm (0.665 inch) thick spacer on the pinion shaft.

### STEP 139

**⚠ WARNING:** *Always wear heat protective gloves to prevent burning your hand when handling heated parts.*

SM121A



BD02D127

Install the assembled pinion shaft in the differential carrier. Heat the pinion shaft outer bearing to 100° C (212° F) in a bearing oven. Wearing heat resistance gloves or mittens, install the bearing on the pinion shaft until contact.

### STEP 140



BD02D128

Using CAS(\*TBS) puller tube, press the dust shield on the input flange.

### STEP 141



BD02D129

Install the input flange on the pinion shaft.

### STEP 142



BD02D130

Put the washer in place on the pinion shaft.

\*TBS: To Be Supplied

## SPECIFICATIONS

Lubricant Capacity .....	22 liters (23.2 U.S. quarts)
Brake Wear Measurement.....	4.0 mm (0.16 inch)
Sun Gear Shaft End Play.....	0.5 to 2.00 mm (0.02 to 0.079 inch)
Drive Pinion Rolling Torque .....	1.1 to 2.3 Nm (9.75 to 20 pound inches)

## SPECIAL TORQUES

Bolts Securing Brake Housing to Axle Housing.....	390 Nm (288 pound feet)
Wheel End Retainer Bolts .....	500 Nm (369 pound feet)
Nut Securing Input Flange (Apply Loctite 262 to Threads).....	700 Nm (516 pound feet)
Bolts Securing Differential Housing to Axle Housing.....	390 Nm (288 pound feet)
Bolts Securing Differential Cover and Ring Gear .....	410 Nm (302 pound feet)
Nut for Securing Brake Tube to Axle Housing .....	100 Nm (74 pound feet)
Brake Tube to Axle Housing Fitting.....	100 Nm (74 pound feet)
Brake Tube Axle Housing Fitting.....	36 Nm (27 pound feet)
Oil Drain Plugs (Outputs).....	50 Nm (37 pound feet)
Oil Fill Plug/Dipstick.....	50 Nm (37 pound feet)
Brake Lining Check Plug .....	50 Nm (37 pound feet)
Brake Bleeder.....	6 Nm (4.4 pound feet)
Brake Return Spring Retainer Bolts .....	34 Nm (25 pound feet)

**STEP 32**

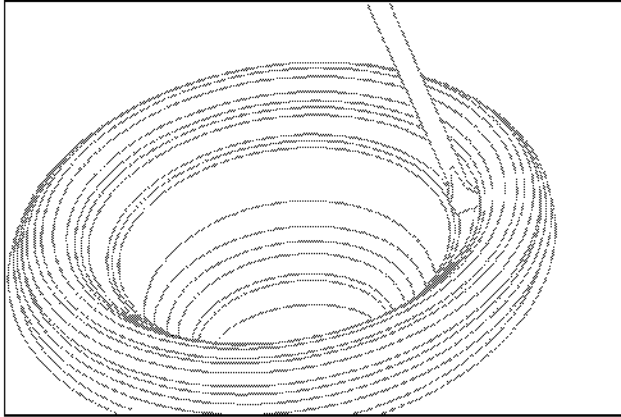

BD07N080-01

Remove and discard the face seal from brake housing.

**STEP 34**

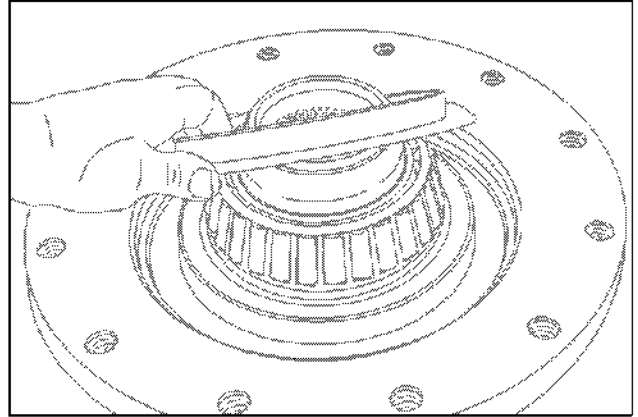

BD07N036-01

Remove the metal face seal ring and discard.

**STEP 33**

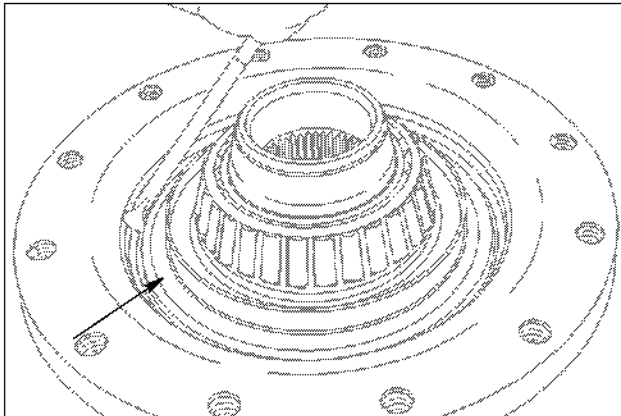

BD07N035-01

Inspect the metal face seal ring, if worn or damaged loosen from wheel end shaft using a pry bar.

**STEP 35**

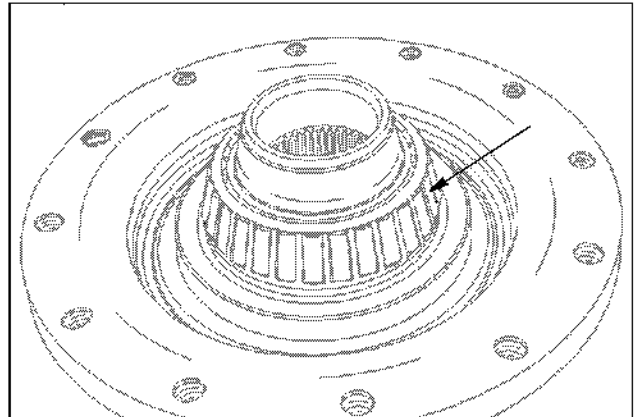

BD07N033-01

Inspect wheel end bearing, if bearing needs replaced cut bearing cage with a die-grinder and remove cage. Score the bearing surface with a die-grinder and break bearing from wheel end shaft using a hammer and chisel.

**STEP 77**

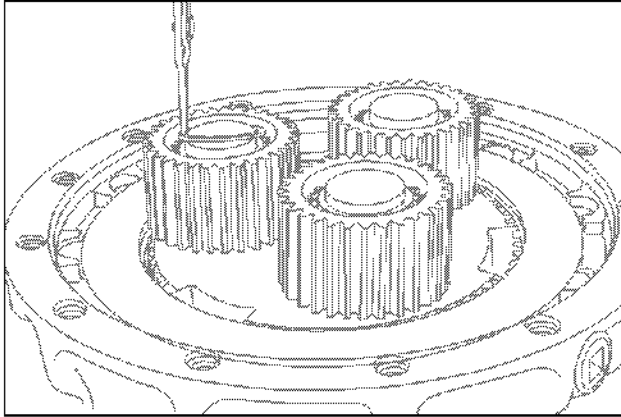

BD07N112-01

Install the three planetary gear retaining rings with snap ring pliers.

**Sun Gear Shaft End Play Adjustment**

**STEP 78**

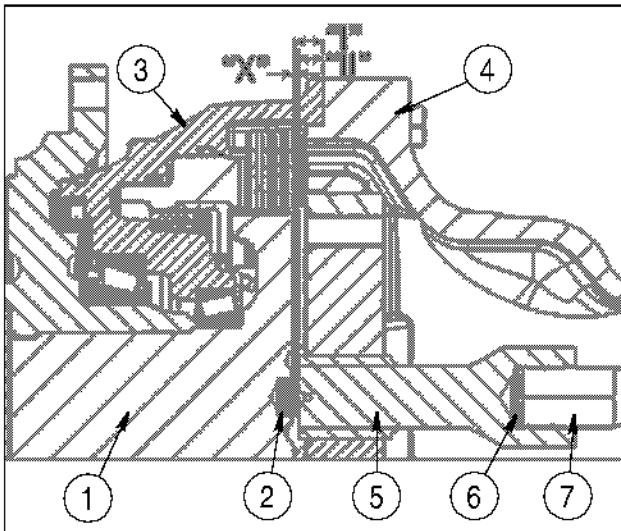

BS08B042

- |                      |                   |
|----------------------|-------------------|
| 1. PLANETARY CARRIER | 5. SUN GEAR SHAFT |
| 2. STOP PIN          | 6. SHIM(S)        |
| 3. BRAKE HOUSING     | 7. STUB SHAFT     |
| 4. AXLE HOUSING      |                   |

**STEP 79**

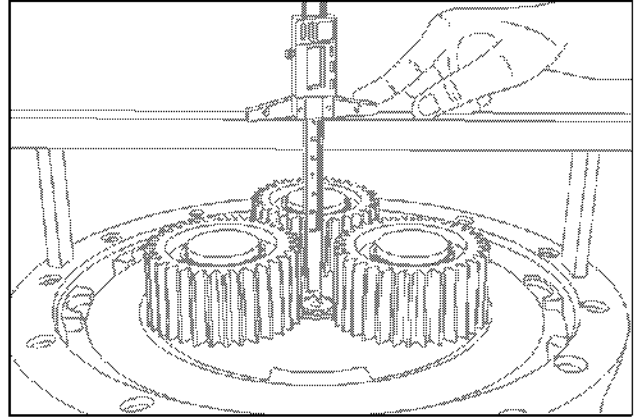

BD08B036-01

Take a measurement from the straight edge to the face of the brake housing, the difference between this measurement and the next measurement will be dimension A.

Measure from the stop pin to the face of the brake housing.

Example:

Dimension A ..... 21.25 mm (0.84 inch)

**STEP 80**

Install the stub shaft in the spline of the axle bevel gear. Make sure the stub shaft is installed all the way into the axle bevel gear.

**STEP 81**

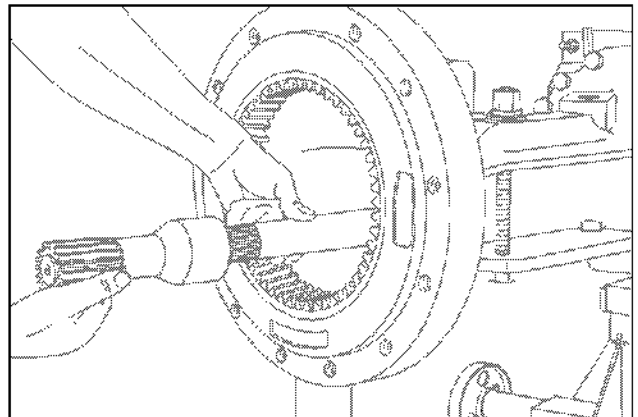

BD08B033-01

Install the sun gear on the stub shaft (without shim) until contact.

**STEP 124**

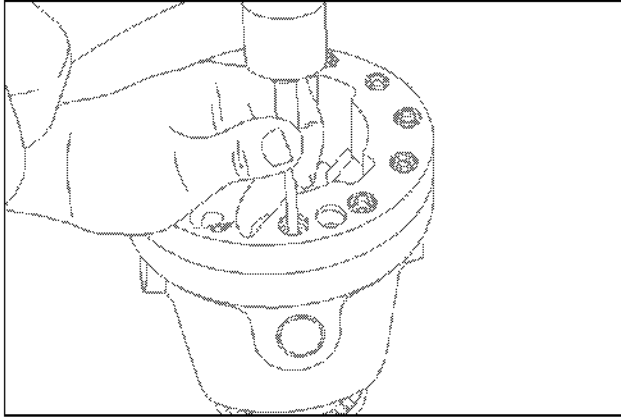

BD07N145-01

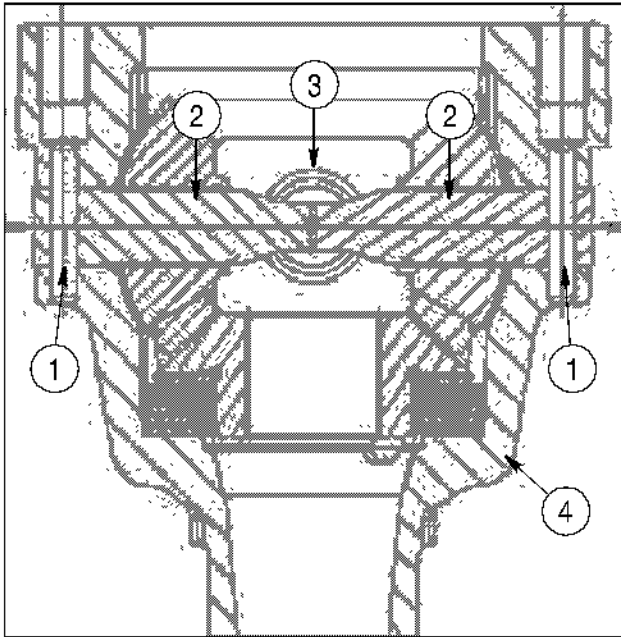

BS08B044

- 1. ROLL PIN SET
- 2. DIFFERENTIAL HALF SHAFT
- 3. DIFFERENTIAL SHAFT
- 4. DIFFERENTIAL HOUSING

Drive both roll pin sets (1) out of the differential housing (4) to remove the differential half shafts (2).

**STEP 125**

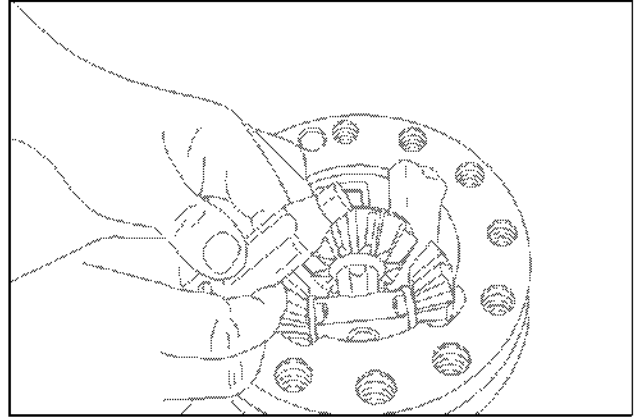

BD07N140-01

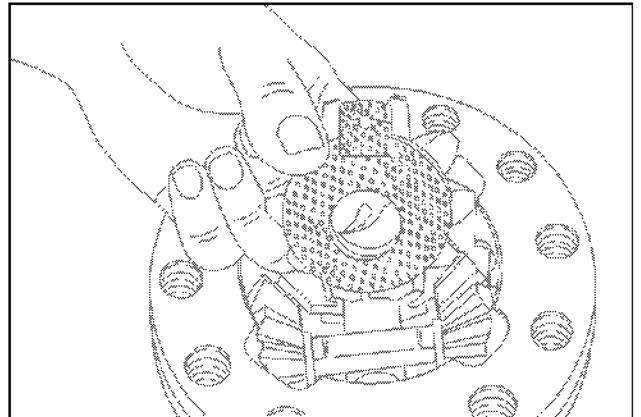

BD07N139-01

Remove the two differential half shafts, spider gears and thrust washers from the differential housing.

**STEP 126**

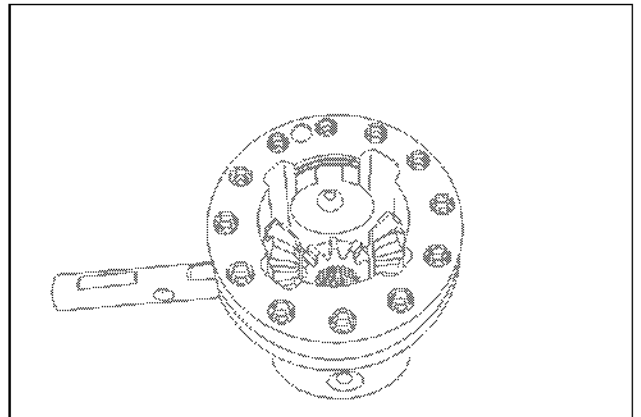

BD07N136-01

Remove the differential shaft from the differential housing.

**STEP 167**

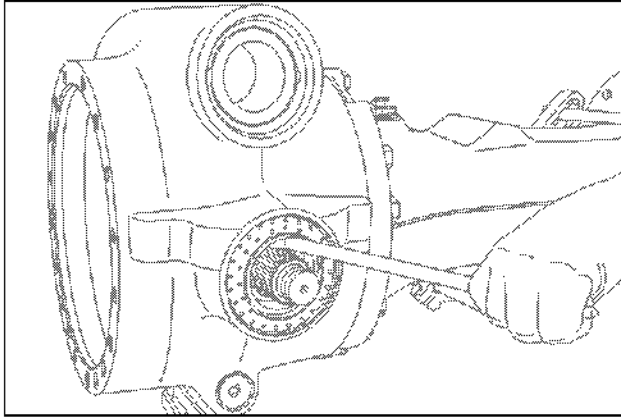

BD06G133-01

Remove the shaft seal from the axle drive housing.

**STEP 170**

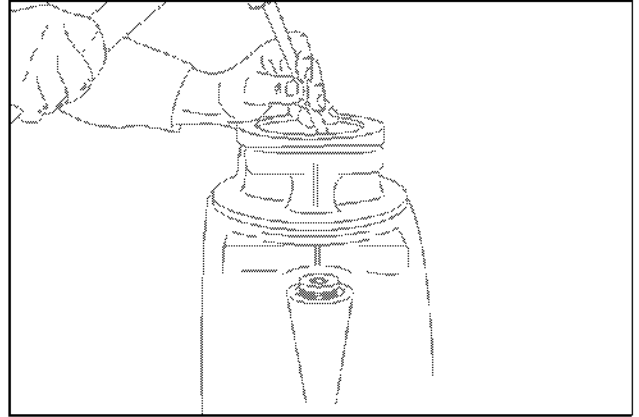

BD07N181-01

Drive inner bearing cup from the differential housing.

**STEP 168**

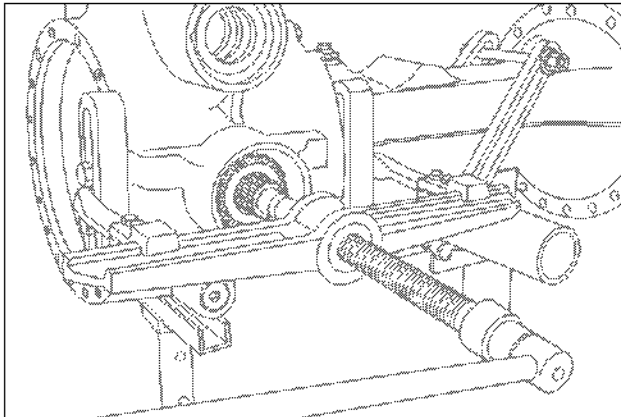

BD06G134-01

Press the input pinion out of the housing.

**STEP 171**

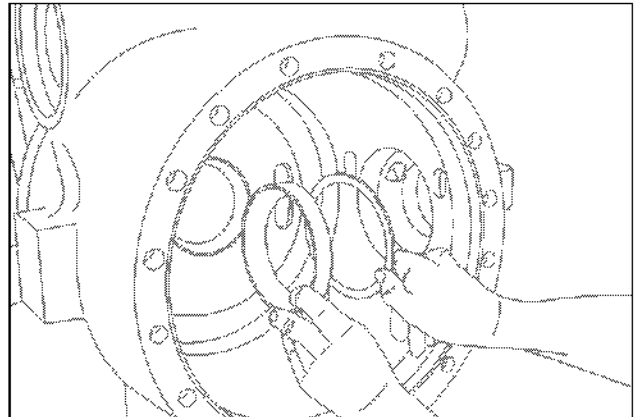

BD06G141-01

Remove inner bearing cup and shim from differential housing.

**NOTE:** Mark shim and bearing cup location to aid in assembly.

**STEP 169**

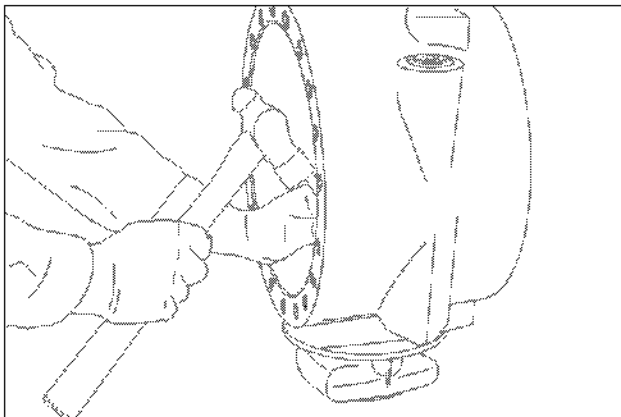

BD07N183-01

Drive outer bearing cup from the differential housing.

**STEP 172**

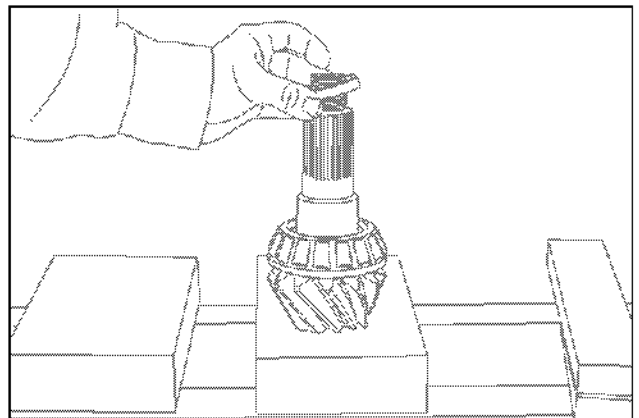

BD07N175-01

Remove the spacer ring from the drive pinion.

## Drive Pinion Bearing Rolling Torque Adjustment

### STEP 206

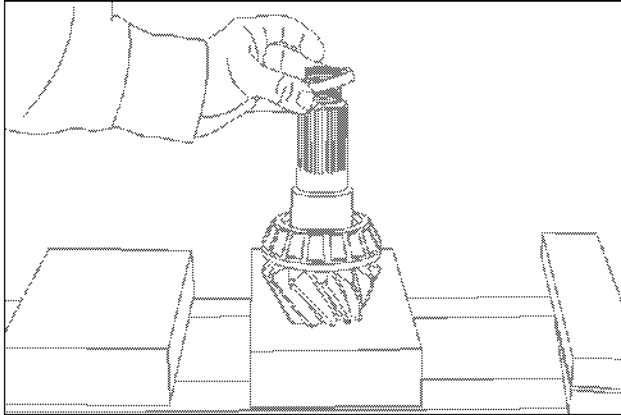

BD07N175-01

Install a 9.03 mm (0.35 inch) thick spacer on the pinion shaft.

### STEP 207

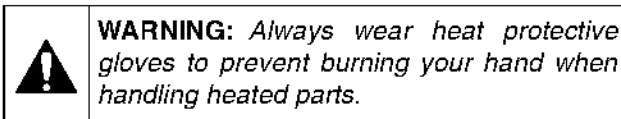

**WARNING:** Always wear heat protective gloves to prevent burning your hand when handling heated parts.

SM121A

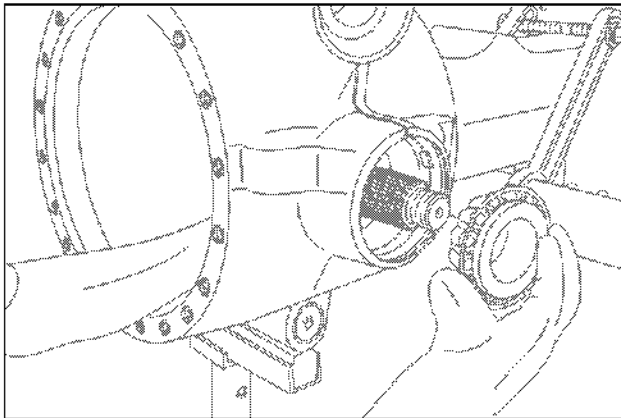

BD06G145-01

Heat the pinion shaft outer bearing to 120° C (248° F) in a bearing oven. Wearing heat resistance gloves or mittens, install the bearing on the pinion shaft until contact.

**NOTE:** Prior to mounting the input flange and tightening the nut, allow the bearing to cool to ambient temperature.

### STEP 208

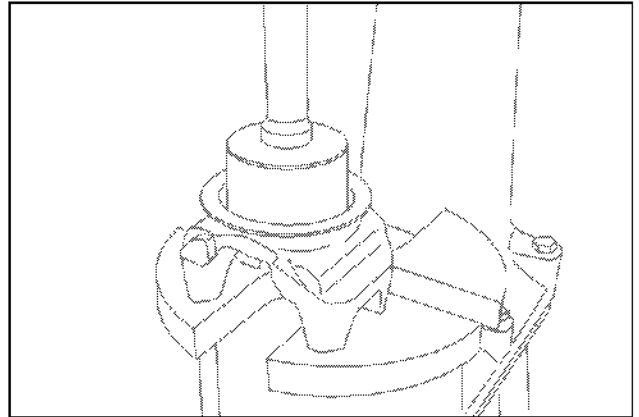

BD06G146-01

Press the dust shield on the input flange.

### STEP 209

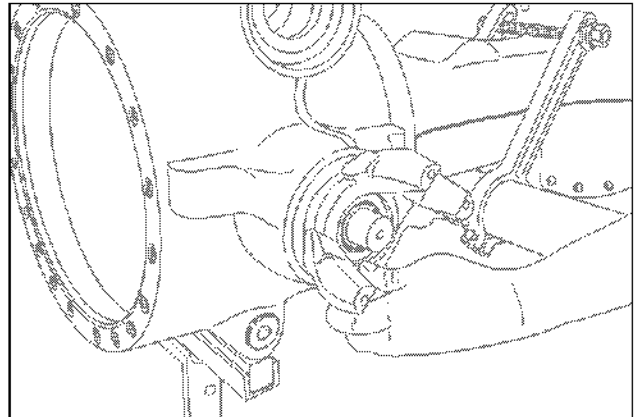

BD06G147-01

Install the input flange on the pinion shaft.

### STEP 210

Put the washer and nut in place on the pinion shaft.

## SPECIAL TORQUES

Coupler to Flywheel Bolts.....	53 to 62 Nm (39 to 46 pound feet)
Engine Drive Shaft to Coupler Bolts .....	53 to 62 Nm (39 to 46 pound feet)
Engine Drive Shaft to Transmission Bolts.....	75 to 81 Nm (55 to 60 pound feet)
Center, Rear and Front Drive Shaft Bolts .....	75 to 81 Nm (55 to 60 pound feet)
Carrier Bearing Bolts .....	99 to 128 Nm (73 to 94 pound feet)
Lock Nut for Yoke on Front Drive Shaft.....	339 to 375 Nm (250 to 275 pound feet)

## FRONT DRIVE SHAFT

### Removal

#### STEP 1

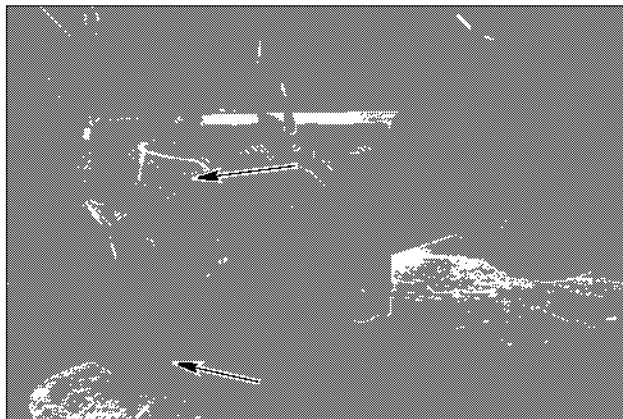

BD03A166

Loosen and remove the bolts and straps that fasten the center drive shaft to the yoke of the front drive shaft.

#### STEP 2

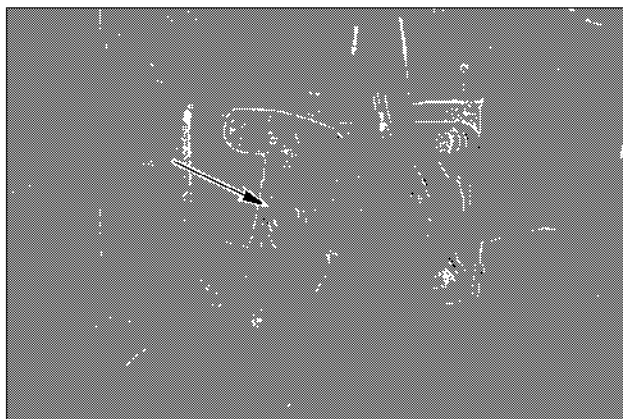

BD03A183

Remove the lock nut that fastens the yoke to the front drive shaft.

#### STEP 3

Make an alignment mark on the yoke and the end of the front drive shaft to make sure that the yoke is installed correctly.

#### STEP 4

Use an acceptable puller and remove the yoke from the end of the front drive shaft.

#### STEP 5

Loosen the set screws that secure the center bearing to the front drive shaft.

#### STEP 6

Remove any paint or rust from the rear of the front drive shaft and apply WD40 or similar oil to loosen any rust between the inner race and the front drive shaft.

#### STEP 7

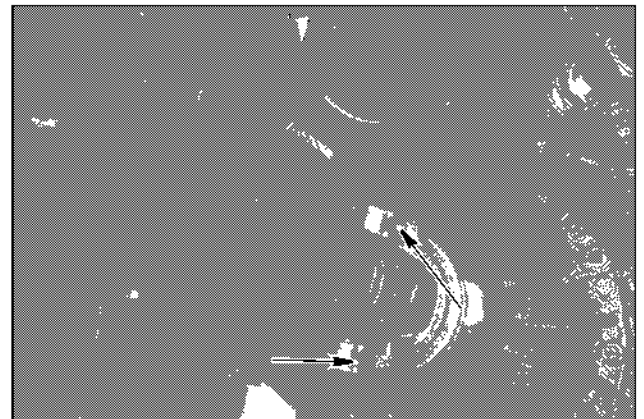

BD03A167

Loosen and remove the bolts and straps that fasten the front drive shaft to the front axle.

#### STEP 8

Use a prybar to disengage the front drive shaft from the front axle and remove the front drive shaft from the machine.

**NOTE:** *If necessary, use a brass hammer to drive the front drive shaft out of the center bearing.*

## WHEELS AND BOLTS

### General Information

The wheel bolts must be tightened after every 20 hours of operation until the wheel bolts stay tight:

- A. If the machine is new.
- B. If a wheel has been removed and installed.

### Torque Specification

Tighten the wheel bolts to 298 Nm (220 pound-feet) in the sequence shown in Figure 1. Then a final torque of 640 to 720 Nm (475 to 530 pound-feet) in the same sequence.

## TIRE PRESSURES

20.5 x 25 L2 .....	Front, 3.45 bar (50 psi), Rear, 2.75 bar (40 psi)
20.5 x 25 L3 .....	Front, 3.45 bar (50 psi), Rear, 2.75 bar (40 psi)
20.5R x 25 XTLA TL .....	Front, 3.45 bar (50 psi), Rear, 2.75 bar (40 psi)
20.5R x 25 XHA TL .....	Front, 3.45 bar (50 psi), Rear, 2.75 bar (40 psi)
20.5 x 25 GP2B .....	Front, 3.45 bar (50 psi), Rear, 2.75 bar (40 psi)
20.5 x 25 L3 .....	Front, 3.45 bar (50 psi), Rear, 2.75 bar (40 psi)
20.5 x 25 RT3B .....	Front, 3.45 bar (50 psi), Rear, 2.75 bar (40 psi)
20.5R x 25 VUT .....	Front, 3.45 bar (50 psi), Rear, 2.75 bar (40 psi)
20.5R x 25 VMT .....	Front, 3.45 bar (50 psi), Rear, 2.75 bar (40 psi)

# SECTION INDEX

## BRAKES

<b>Section Title</b>	<b>Section Number</b>
Removal and Installation of Brake Components .....	7001
Hydraulic Brake Troubleshooting .....	7002
Brake Pump .....	7003
Brake Accumulators .....	7004
Parking Brake .....	7008

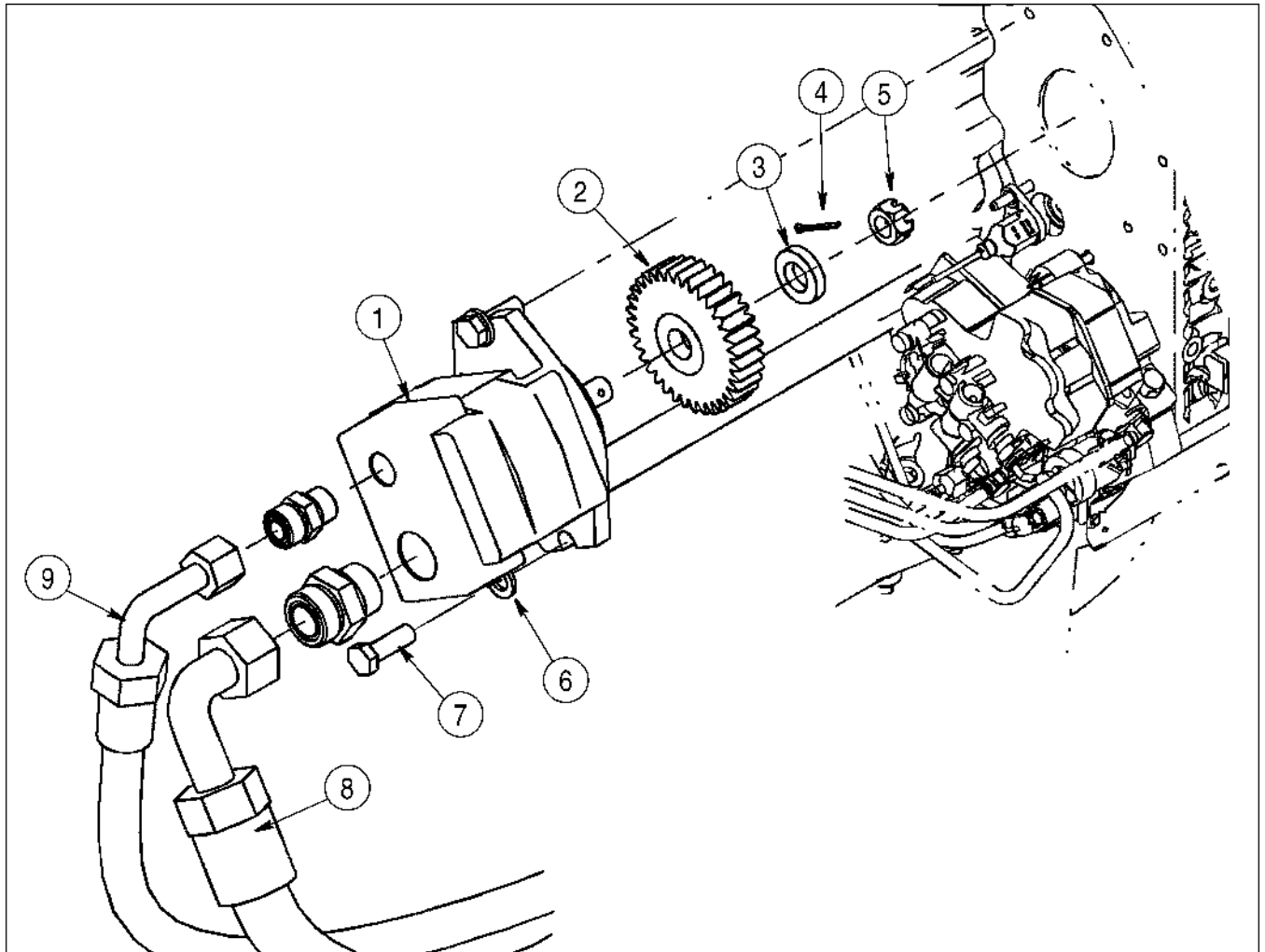

BC05M139

- |               |                |                       |
|---------------|----------------|-----------------------|
| 1. BRAKE PUMP | 4. COTTER PIN  | 7. MOUNTING BOLTS (2) |
| 2. DRIVE GEAR | 5. SLOTTED NUT | 8. SUCTION HOSE       |
| 3. WASHER     | 6. WASHERS (2) | 9. PRESSURE HOSE      |

**BRAKE PUMP ILLUSTRATION**

## BRAKE PUMP OUTPUT TEST

1. Connect the flowmeter to the brake pump as shown below.
2. Make sure the load control of the flowmeter is open. Start the engine. Run the engine at full throttle. Make sure the oil is at operating temperature.
3. Measure the flow at 0 bar (0 psi). Record the flow reading. Slowly close the load valve on the flowmeter and read the flow at 170 bar (2500 psi). Record the flow reading.
4. Divide the flow reading at 170 bar (2500 psi) by the reading at 0 bar (0 psi). Multiply the result by 100. This is the percent efficiency of the pump. If the efficiency of the pump is less than 85%, repair or replace the pump.

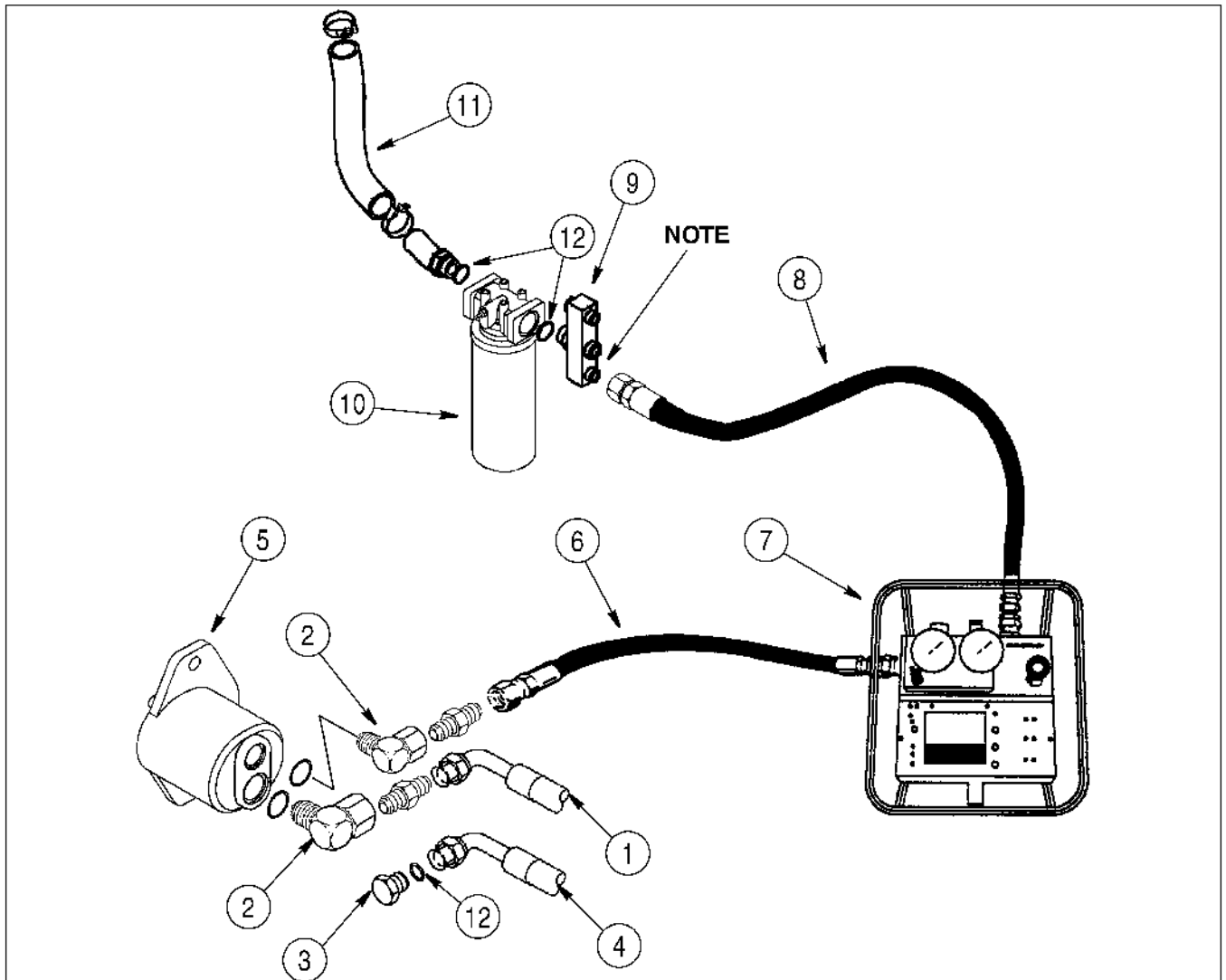

BS02M026

- |                             |                          |                              |
|-----------------------------|--------------------------|------------------------------|
| 1. FROM HYDRAULIC RESERVOIR | 5. BRAKE PUMP            | 9. FILTER INLET MANIFOLD     |
| 2. ELBOW                    | 6. FLOWMETER INLET HOSE  | 10. FILTER                   |
| 3. PLUG                     | 7. CAS10280 FLOWMETER    | 11. FILTER TO RESERVOIR HOSE |
| 4. TO ACCUMULATOR VALVE     | 8. FLOWMETER OUTLET HOSE | 12. O-RING                   |

**NOTE:** IF UNIT IS EQUIPPED WITH AUXILIARY STEERING A TEE FITTING WILL HAVE TO BE USED IN THIS LOCATION

### BRAKE PUMP OUTPUT TEST

## ACCUMULATOR SPECIAL TORQUES

Gas Charging Valve.....20Nm (15 pound-feet)

### SPECIAL TOOLS

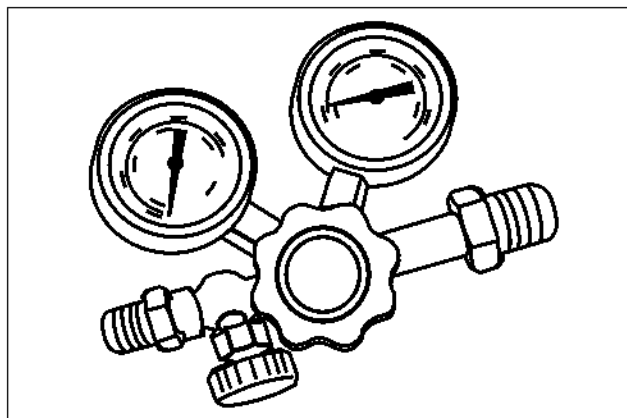

BS06M002

380001676 NITROGEN REGULATOR VALVE

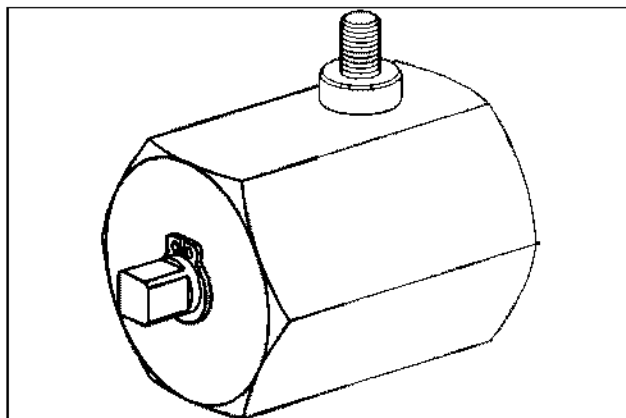

BC04A001

380001168 ACCUMULATOR VALVE ADAPTER

**NOTE:** Check your inventory of tools, if you have nitrogen charging kit CAS10899 use it in place of the above listed tools.

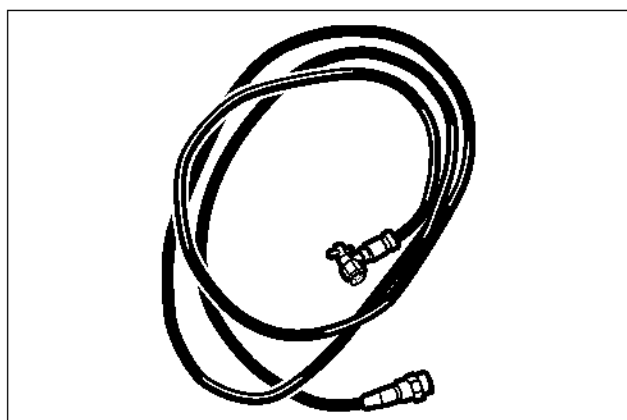

BS06M003

380001390 ACCUMULATOR CHARGING HOSE

## SECTION INDEX

### HYDRAULICS

<b>Section Title</b>	<b>Section Number</b>
How to Read Hydraulic Schematics . . . . .	8000
Removal and Installation of Hydraulic Components . . . . .	8001
Hydraulic Specifications, Troubleshooting, and Pressure Checks . . . . .	8002
Cleaning the Hydraulic System . . . . .	8003
Hydraulic Pump . . . . .	8004
Loader Control Valve . . . . .	8005
Cylinders . . . . .	8006
Coupler Solenoid Locking Valve . . . . .	8007
Ride Control Accumulator . . . . .	8013
Ride Control Valve . . . . .	8014

## Composite Symbols

### One - Way Valves

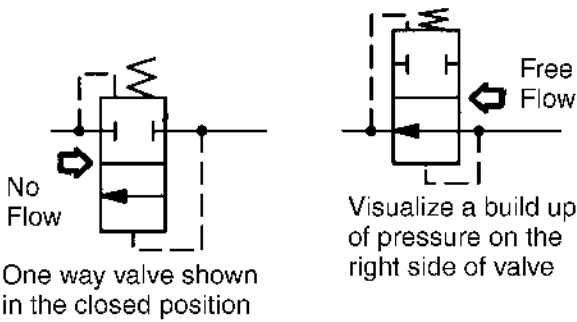

BS07B678

A more complex one way valve is shown. This directional control symbol uses a multiple envelope (square) system that has a separate square for each position. Remember all of the port connections are made to the envelope that shows the neutral condition of the valve. Within each envelope are arrows showing the flow paths when the valve is shifted to that position.

### Two - Position Valves

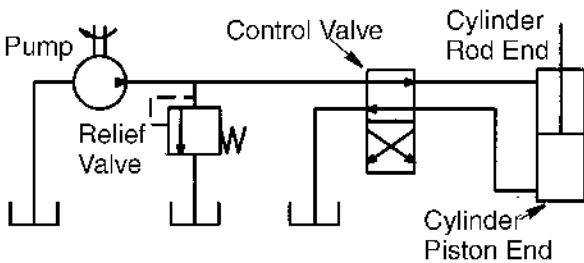

BS07B679

A simple control valve has two envelopes (representing the spool) if it is a two position valve. The envelopes show the flow conditions when they are in one position. The above schematic is showing that oil is being supplied to the rod end of the cylinder. If we visualize the directional control valve moved to the other position, it would be shown as below.

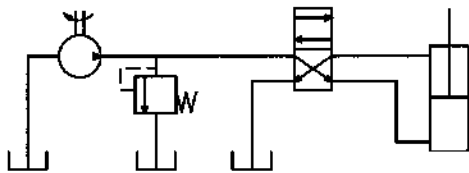

BS07B710

Pressurized oil is being supplied to the piston end of the cylinder and oil from the rod end of the cylinder is allowed to flow to the reservoir.

### Three - Position Valves

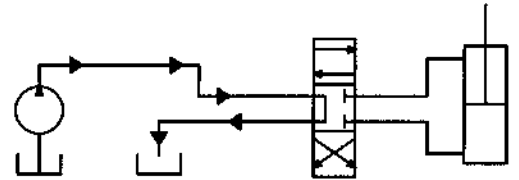

BS07B680

OPEN CENTER THREE POSITION VALVE

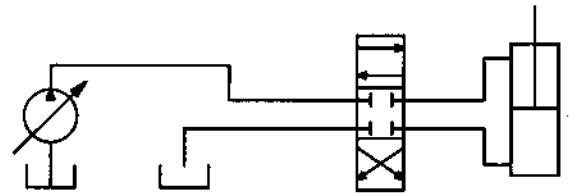

BS07B681

CLOSED CENTER THREE POSITION VALVE

Three position valves will have a centered (neutral) position. The centered position can be either open or closed to flow. The open center is usually used with a fixed displacement pump and the closed center is usually used with a variable displacement pump.



Presssure  
Switch

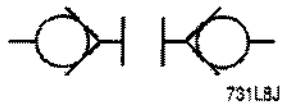

Quick Disconnects  
(Disconnected)

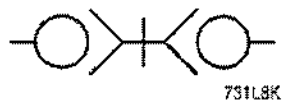

Quick Disconnects  
(Connected)

BS07B707

## REMOTE CONTROL VALVE

### Removal

#### STEP 27

Park the machine on a level surface and lower the bucket to the floor. Stop the engine and apply the parking brake.

**IMPORTANT:** *With the engine NOT running, pump the brake repeatedly to be sure the brake accumulators have no hydraulic pressure, put the ignition switch in the ON position then move the loader control valve back and forth several times to release any hydraulic pressure in the pilot control circuit, turn ignition switch OFF.*

#### STEP 28

Place the master disconnect switch in the OFF position.

#### STEP 29

Unlatch and open the right hand side access door.

#### STEP 30

Lift the access door up and remove the access door from the pins.

#### STEP 31

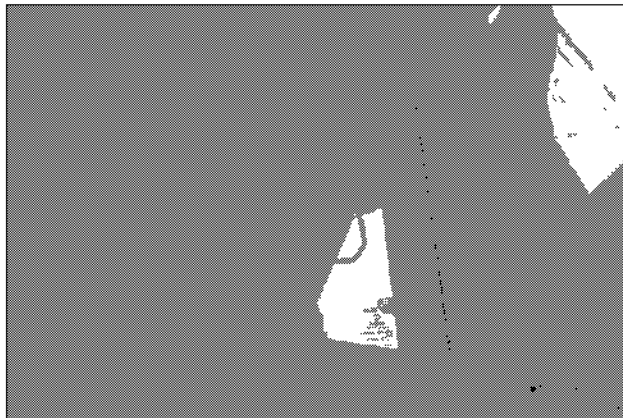

BD06F207

Unlatch and open the window on the right hand side.

#### STEP 32

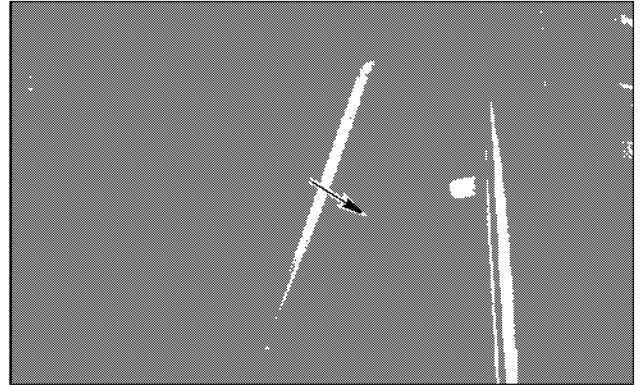

BD06F208

Open and remove the access panel.

#### STEP 33

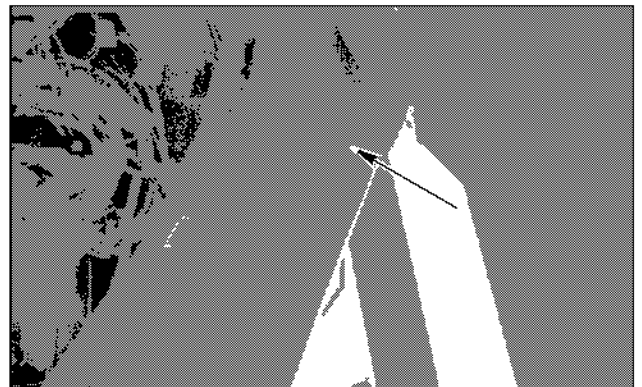

BD06F209

Remove the front access panel.

#### STEP 34

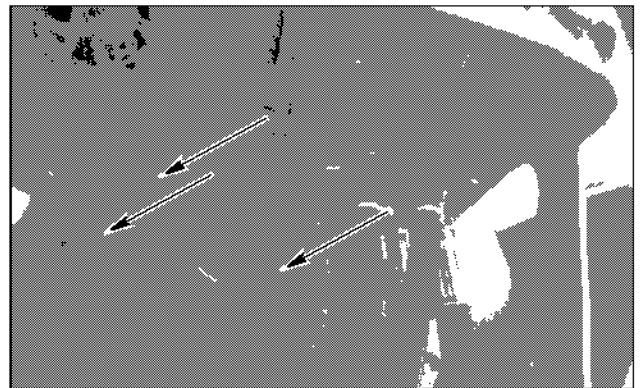

BD06F210

Disconnect the electrical connectors for the remote control valve.

#### STEP 35

Loosen the filler cap on the reservoir to release any air in the reservoir. Connect a vacuum pump to the hydraulic reservoir, turn on the pump.

## LIFT CYLINDERS

### Removal

#### STEP 76

Park the machine on a level surface and lower the bucket to the floor. Stop the engine and apply the parking brake.

**IMPORTANT:** *With the engine NOT running, pump the brake repeatedly to be sure the brake accumulators have no hydraulic pressure, put the ignition switch in the ON position then move the loader control valve back and forth several times to release any hydraulic pressure in the pilot control circuit, turn ignition switch OFF.*

#### STEP 77

Relieve the pressure in the ride control accumulator with the manual bleeder valve located at the rear of the front chassis.

#### STEP 78

Loosen the filler cap on the hydraulic reservoir to release any pressure.

#### STEP 79

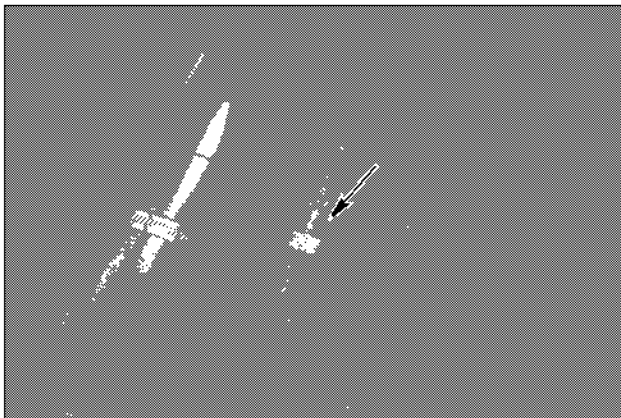

BD01D708

Tag and disconnect the hoses on each side of the lift cylinder. Install plugs in the hoses and caps on the fittings.

#### STEP 80

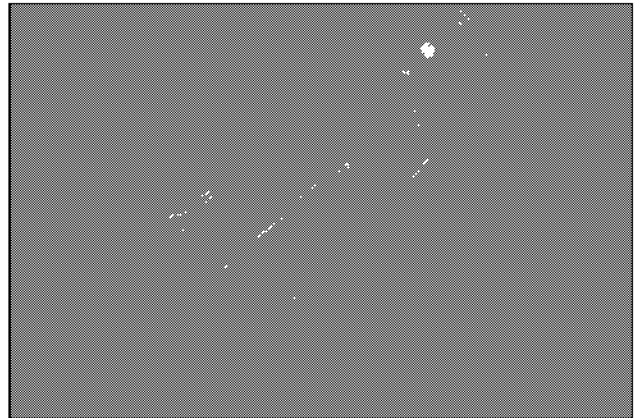

BD01D709

Loosen and remove the bolt, washer and spacer that hold the pivot pin for the yoke.

#### STEP 81

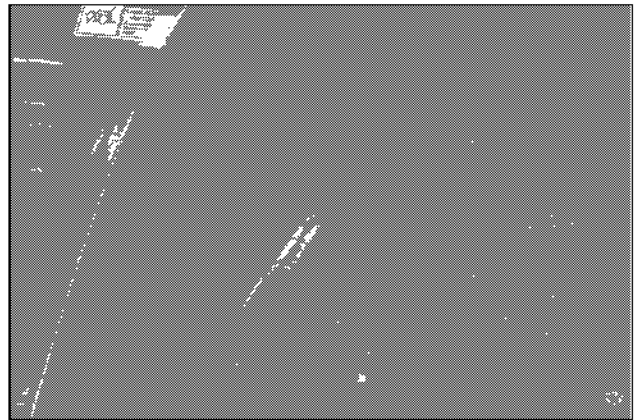

BD01D711

Use a proper lifting device and secure a strap around the lift cylinder.

#### STEP 82

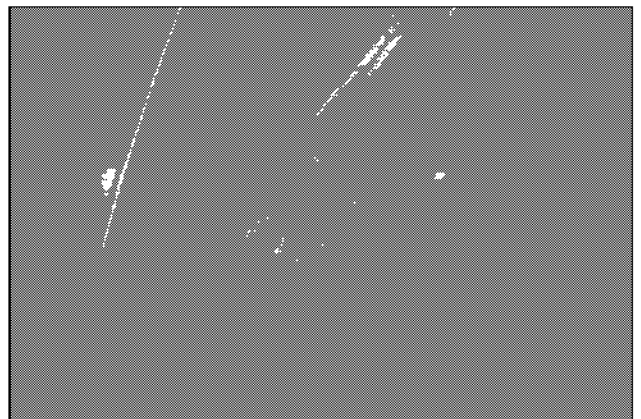

BD01D712

Remove the pivot pin from the yoke end of the lift cylinder.

## OIL COOLER

### Removal

#### STEP 147

Park the machine on a level surface and lower the bucket to the ground. Stop the engine and apply the parking brake.

#### STEP 148

Place the master disconnect switch in the OFF position.

#### STEP 149

Raise the engine hood and remove the shield on the right side of the machine between the tire and the oil cooler.

#### STEP 150

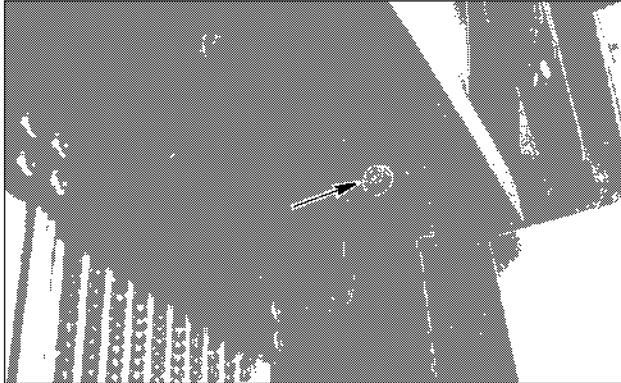

BD03A120

Have assistant hold side panel in raised position, remove two mounting screws, remove side panel.

#### STEP 151

Loosen the filler cap on the hydraulic reservoir to release the air pressure in the reservoir. Connect a vacuum pump to the hydraulic reservoir, turn on the pump.

#### STEP 154

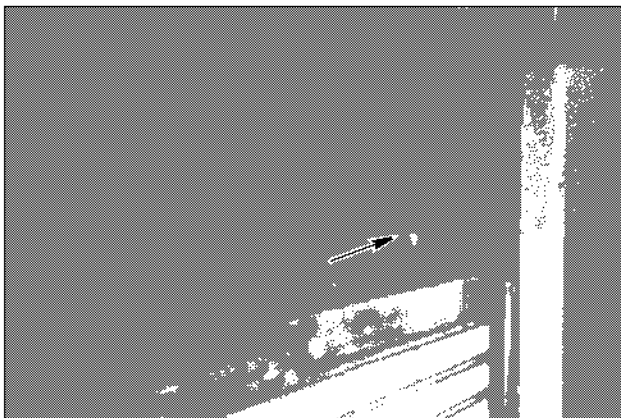

#### STEP 152

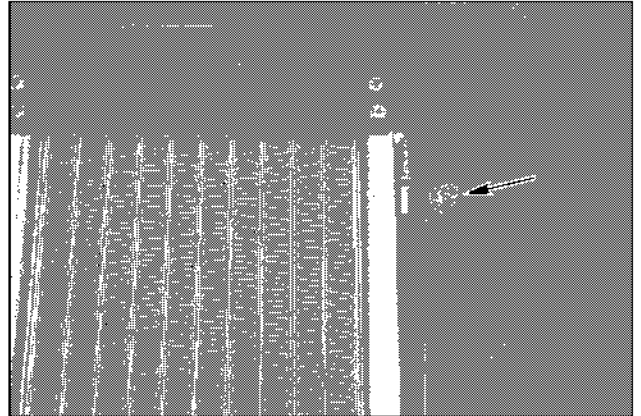

BD03A154

Disconnect the top hose and install a plug in the hose and a cap on the fitting.

#### STEP 153

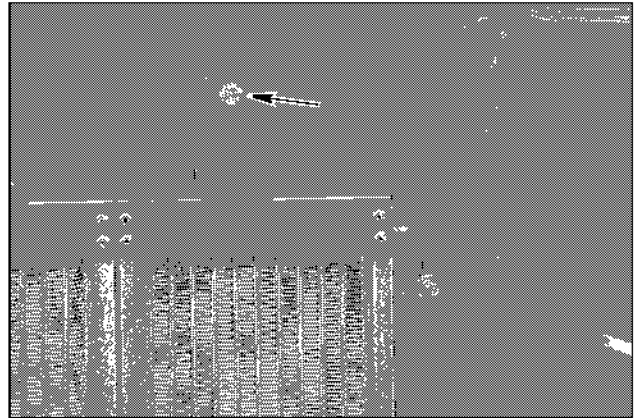

BD03A179

Loosen and remove the bolt and washer that fasten the oil cooler to the cooling frame.

BD03A217

Raise oil cooler and disconnect the hose from the bottom of the oil cooler. Install a plug in the hose and a cap on the fitting. Remove oil cooler from the machine.

# Section 8002

8002

## HYDRAULIC SPECIFICATIONS, TROUBLESHOOTING, AND PRESSURE CHECKS

**STEP 5**

Make sure that the temperature of the hydraulic oil is at least 52°C to 60°C (125°F to 140°F). The following is the procedure for heating the hydraulic oil.

- A. Apply the parking brake.
- B. Start the engine.
- C. To measure the oil temperature with the instrument cluster:
  - Press the up or down arrow key.
  - Stop at the info screen with the temperatures that need to be monitored are on.
- D. Run engine at full throttle.
- E. Hold the bucket control lever in the ROLLBACK position while raising and lowering the lift arms from ground level to full height.
- F. Continue this procedure until the temperature of the hydraulic oil is 54° to 57°C (129° to 134°F).

**STEP 6**

Start the engine and remove the safety link (refer to step 2) and lower the loader arms to the ground.

**STEP 7**

Operate the machine at full throttle. Tilt the bucket to a full rollback position and hold while observing the pressure gauge.

**STEP 8**

The pressure should read between 248 and 255 bar (3596 to 3700 psi).

**STEP 9**

If the pressure is not within the specifications, it will be necessary to adjust the main relief valve.

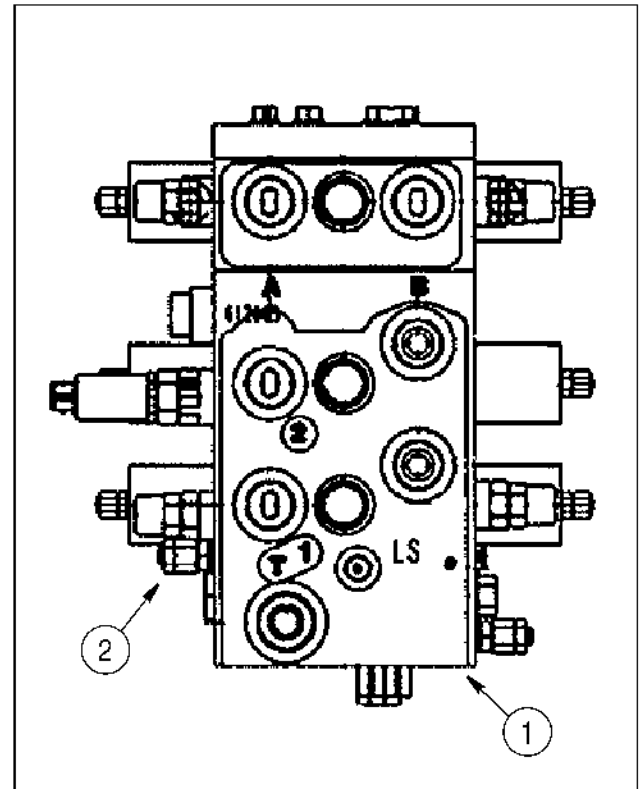
**Adjustment****STEP 10**

BS01A046

1. LOADER CONTROL VALVE
2. RELIEF VALVE ADJUSTMENT

With the engine running and the loader on the ground, loosen the jam nut and turn the adjustment screw (2) clockwise for higher pressure or counterclockwise for lower pressure.

**NOTE:** 1/4 turn of the adjusting screw changes the pressure setting approximately 35 bar (500 psi).

**STEP 11**

Repeat the Pressure Check Procedure.

**STEP 12**

If the pressure is not within the specifications, repeat steps 10 and 11 until pressure is within the required range.

**STEP 13**

Stop the engine before removing the pressure gauge.

## CLEANING THE HYDRAULIC SYSTEM

1. Prepare the portable filter on page 3 by doing the following steps:
  - A. Remove all the hydraulic oil from the inlet and outlet hoses for the portable filter.
  - B. Remove the filter element from the portable filter.
  - C. Remove all hydraulic oil from the portable filter.
  - D. Clean the inside of the housing for the filter element.
2. You must know whether the contamination is microscopic or visible. See types of contamination on page 4.
3. If the contamination is microscopic:
  - A. Check the maintenance schedule for the machine to learn if the hydraulic oil must be changed. If needed, change the hydraulic oil. See Section 1002 for specifications. Change the hydraulic filter.
  - B. Do steps 6 through 35.
4. If the contamination is visible:
  - A. Change the hydraulic oil and hydraulic filter. See Section 1002 for specifications.
  - B. Do steps 5 through 35.
5. Check the amount of contamination in the hydraulic system by doing the following steps:
  - A. Disassemble one cylinder in two different circuits. Check for damage to seals, scoring of the cylinder wall, etc. Repair the cylinders as necessary.
  - B. If, in your judgment, the damage to the cylinders was caused by sever contamination and is not the result of normal wear, it is necessary to remove, clean and repair valves, pump, lines, cylinders, hydraulic reservoir, etc. in the hydraulic system.
6. Remove the breather from the reservoir and connect the vacuum pump to the opening. Start the vacuum pump.
7. Loosen and remove the drain plug from the reservoir.
  8. Using the fitting kit shown on page 3, install the valve in the hole for the drain plug. Make sure that the valve is closed.
  9. Stop the vacuum pump.
  10. Connect the inlet hose for the portable filter to the valve that is installed in the hole for the drain plug.
  11. Disconnect the vacuum pump from the hydraulic reservoir air breather hose. Remove the filler cap.
  12. Install the outlet hose for the portable filter in the hydraulic reservoir filler neck.
  13. Open the valve that is installed in the hole for the drain plug.
  14. Move the switch for the portable filter to the ON position. Start and run the engine at 1500 rpm (r/min).
  15. Run the portable filter for 10 minutes.
  16. Continue to run the portable filter. Increase the engine speed to full throttle. Heat the oil to operating temperature by doing the following steps:
    - A. Hold the blade control lever in the TILT position for five seconds.
    - B. Return the blade control lever in the NEUTRAL position for five seconds.
    - C. Repeat steps A and B until the oil in the hydraulic system is at operating temperature.
  17. Continue to run the engine at full throttle. Continue to run the portable filter.
  18. Operate each hydraulic circuit to completely extend and retract the cylinders. Continue to operate each hydraulic circuit two times, one after the other for 45 minutes.
  19. Decrease the engine speed to low idle.
  20. Continue to run the portable filter for 10 minutes.
  21. Stop the portable filter.
  22. Stop the engine.
  23. Remove the hose from the hydraulic reservoir.

**STEP 6**

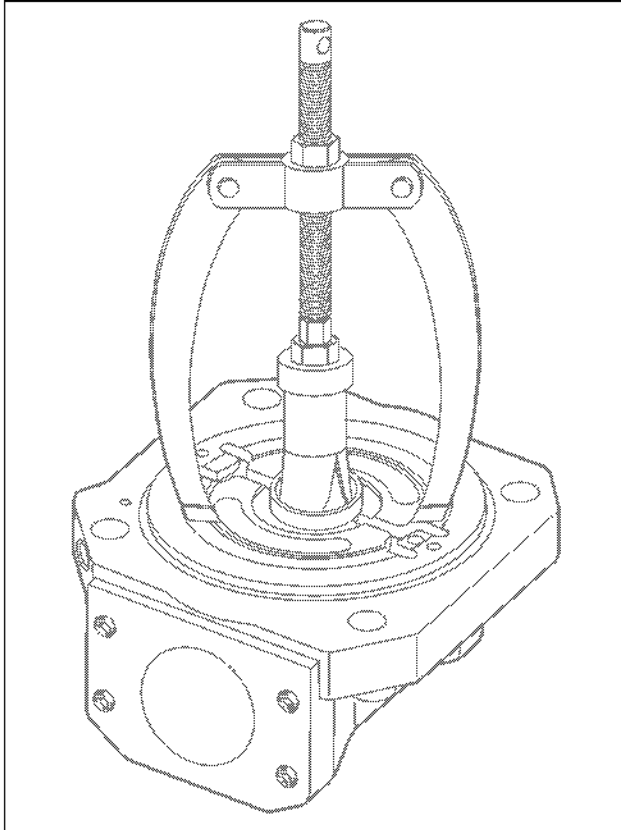

BC06F555-01

Use a suitable bearing race puller and pull the bearing race from the end cover.

**NOTE:** Do not damage the sealing surfaces.

**STEP 7**

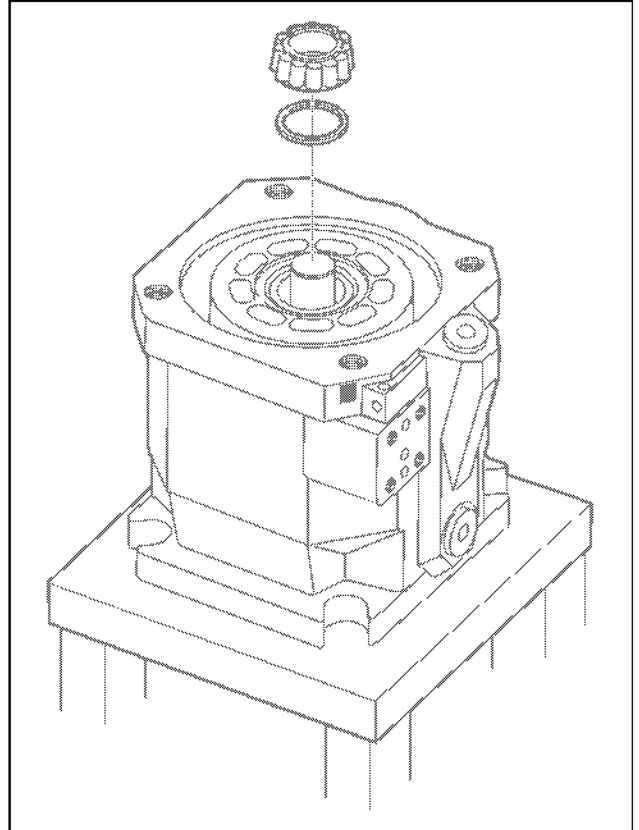

BC06F556-01

Remove the bearing and shim.

**STEP 8**

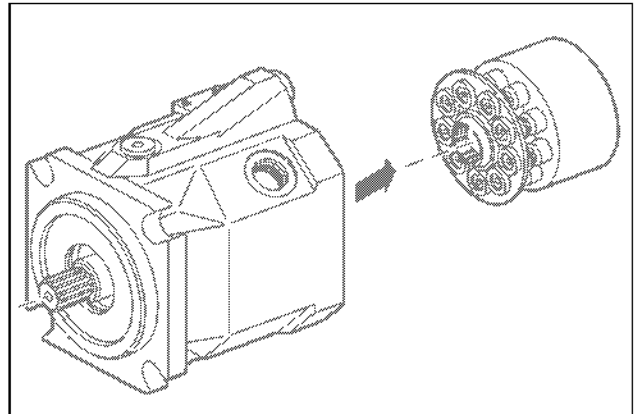

BC06F557-01

Remove the rotary group from the housing in a horizontal position.

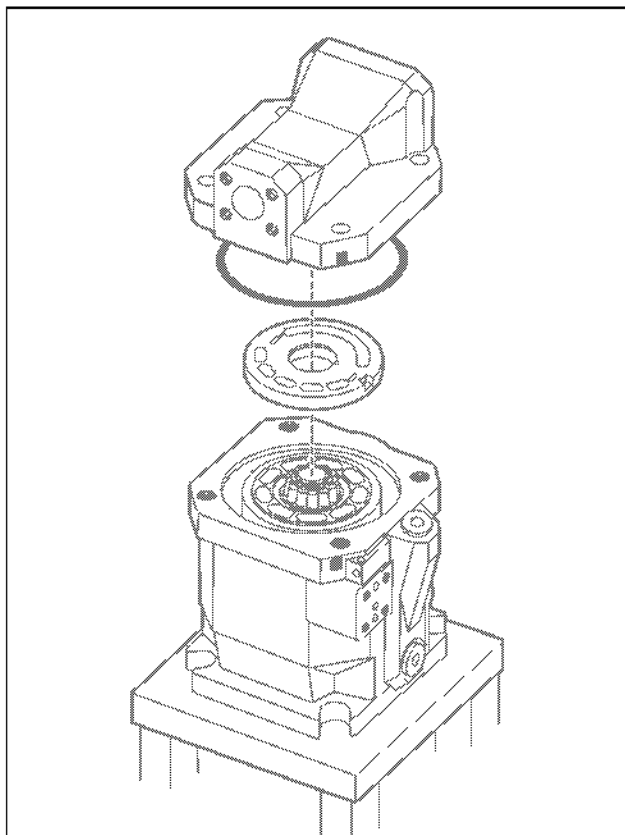
**STEP 41**

BC06F589-01

Install a new O-ring on the end cover, place the flow plate onto the rotating group with aligning notch up. Place the end cover onto the housing, make sure that the aligning pin in the end cover aligns with the slot in the flow plate.

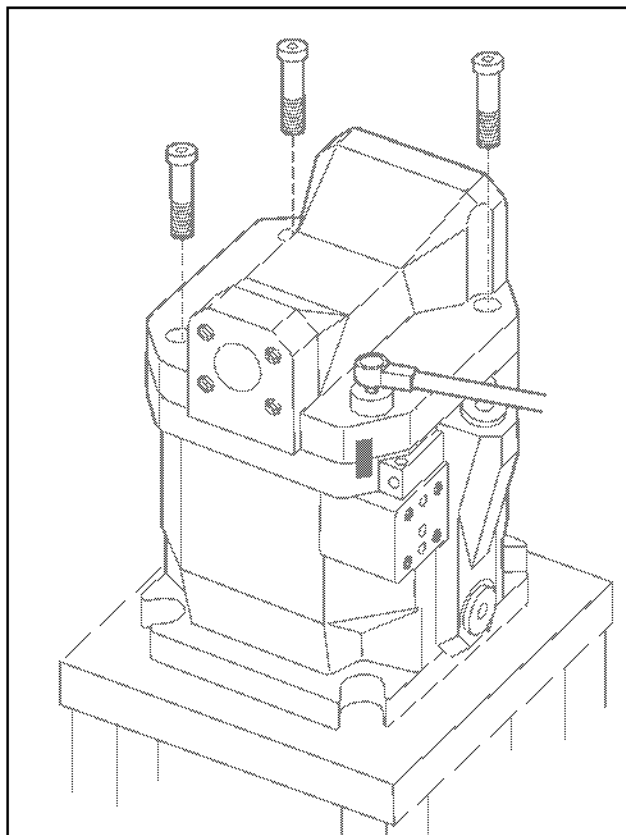
**STEP 42**

BC06F553-01

Install and tighten the four bolts to 165 Nm (121.5 pound-feet).

## LOADER CONTROL VALVE

### Disassembly

#### STEP 1

Remove valve from machine, see section 8001.

#### STEP 2

Remove bolts (14), covers (16), and springs (17).

#### STEP 3

Remove cap (24), spring (17), and plug (28).

#### STEP 4

Use wooden dowel or brass drift and push spools (20 and 26) from housing (1).

**IMPORTANT:** Do not force spools from housing, if spool binds work back and forth until spool comes out freely.

**NOTE:** Repeat steps 2 and 4 for 3 and 4 spool valve configuration.

#### STEP 5

Remove anticavitation valves (7 and 27).

**NOTE:** Repeat step 5 for 3 and 4 spool anticavitation valves (31).

#### STEP 6

Remove cone (13).

#### STEP 7

Remove pressure relief valve (8 and 12).

#### STEP 8

Remove flow limit valve (9).

#### STEP 9

Remove check valves (5).

#### STEP 10

Remove flow limiting valve (11).

#### STEP 11

Remove the pilot pressure reducing valve (6).

#### STEP 12

Remove bolts (3) and washers (4), remove plate (2) from housing (1).

**NOTE:** For 4 spool configuration remove nut (32) from stud (33), remove valves from housing (1).

#### STEP 13

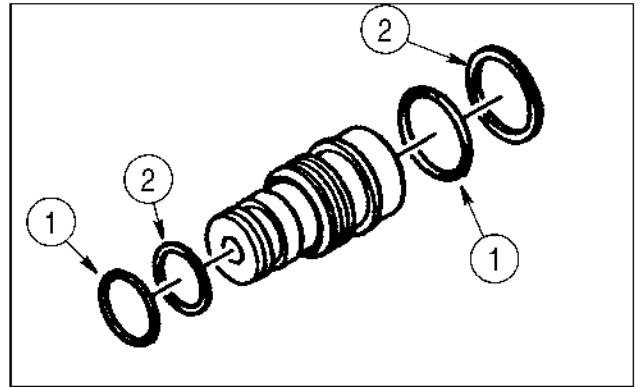

BS03C026

1. O-RINGS

2. THRUST RINGS

Remove and discard O-rings and thrust rings from flow limit valve (11).

#### STEP 14

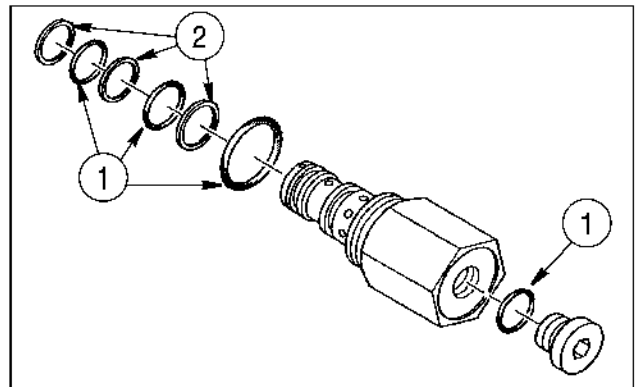

BS03C025

1. O-RINGS

2. THRUST RINGS

Remove and discard O-rings and thrust rings from pilot pressure reducing valve (9).

## SPECIFICATIONS

	Approximate weight
Lift Cylinder - XT and Z-Bar .....	75.7 kg (167 pounds)
Bucket Cylinder - Z-Bar Models .....	75.6 kg (167 pounds)
Bucket Cylinder - XT Models .....	73 kg (160 pounds)

## SPECIAL TORQUES

Screw in Gland Z-Bar Bucket Cylinder .....	135 to 542 Nm (100 to 400 pound-feet)
Screw in Gland XT Bucket Cylinder .....	135 to 542 Nm (100 to 400 pound-feet)
Screw in Gland for Lift Cylinders XT and Z-Bar Models .....	135 to 542 Nm (100 to 400 pound-feet)
Piston Bolt for Lift Cylinders XT and Z-Bar Models .....	1780 to 2180 Nm (1312 to 1607 pound-feet)
Piston Bolt for Z-Bar Bucket Cylinder .....	3310 to 3850 Nm (2440 to 2838 pound-feet)
Piston Bolt for XT Bucket Cylinder .....	1780 to 2180 Nm (1312 to 1607 pound-feet)
Lock Screw for all Cylinders .....	2.3 Nm (20 pound-inches)

## SPECIAL TOOLS

Torque Multiplier .....	CAS1039
-------------------------	---------

## REPLACING THE BUSHINGS FOR THE LIFT CYLINDERS

### Disassembly

1. Put the piston tube (4) in a press, refer to Figure 4.
2. Use an acceptable driver to press the wipers (1) and bushings (2) out of the piston tube (4).
3. Clean the bore for the bushings (2) in the tube (4).

### Assembly

1. Use an acceptable driver to press a new bushing (2) into the tube (4) until the bushing (2) is centered in the tube (4).
2. Use an acceptable driver to install the wipers (1) in the tube (4). The lips of the wipers (1) must be toward the outside of the bore.

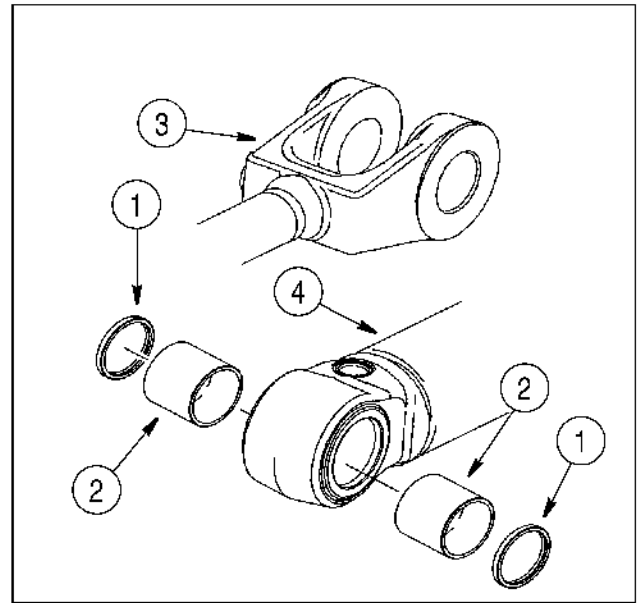

BS01C003

- |            |                    |
|------------|--------------------|
| 1. WIPER   | 3. PISTON ROD YOKE |
| 2. BUSHING | 4. TUBE            |

**FIGURE 4. BUSHING AND WIPER REMOVAL AND REPLACEMENT LIFT CYLINDERS**

## SPECIFICATIONS

Ride Control Accumulator Dry Nitrogen Pressure.....	See chart on page 6
Ride Control Accumulator Fluid Capacity.....	3.79 liters (231 cu. inch)
Ride Control Accumulator Maximum Operating Pressure.....	248.4 bar (3600 psi)

## ACCUMULATOR SPECIAL TORQUES

Accumulator Gas Charging Valve Cap.....	13.6 Nm (10 pound-feet)
Gas Charging Valve.....	88 to 102 Nm (65 to 75 pound-feet)
Cap screws for the protection bracket.....	54 to 61 Nm (480 to 540 pound-inches)
Gland.....	163 to 176 Nm (120 to 130 pound-feet)

## SPECIAL TOOLS

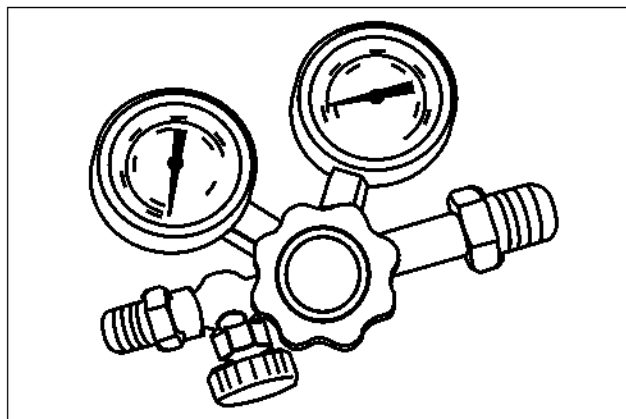

380001676 NITROGEN REGULATOR VALVE

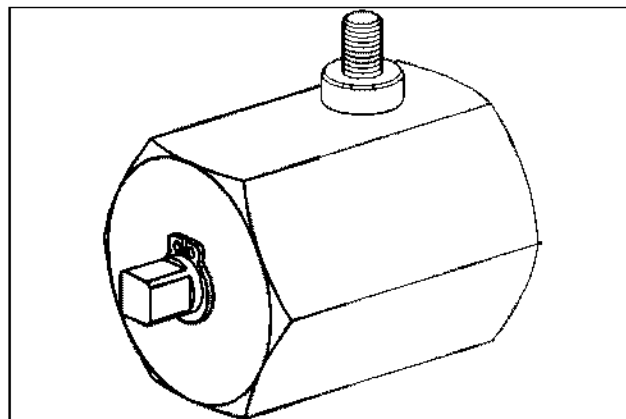

380001168 ACCUMULATOR VALVE ADAPTER

*Check your inventory of tools, if you have nitrogen charging kit CAS10899 use it in place of the above listed tools.*

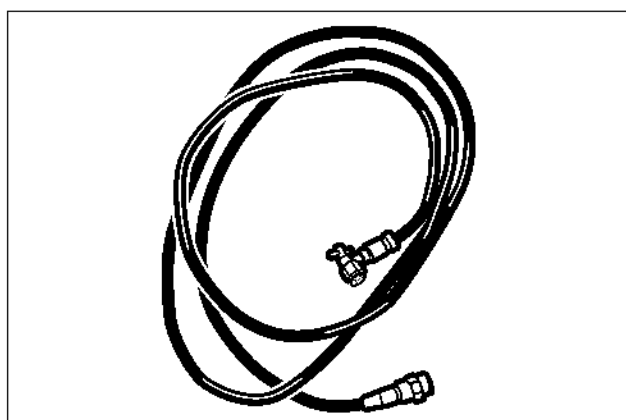

380001390 ACCUMULATOR CHARGING HOSE

# Section 9002

9002

## AIR CONDITIONING TROUBLESHOOTING AND SYSTEM CHECKS FOR SYSTEMS WITH HFC-134A REFRIGERANT

## Visual and Leak Check

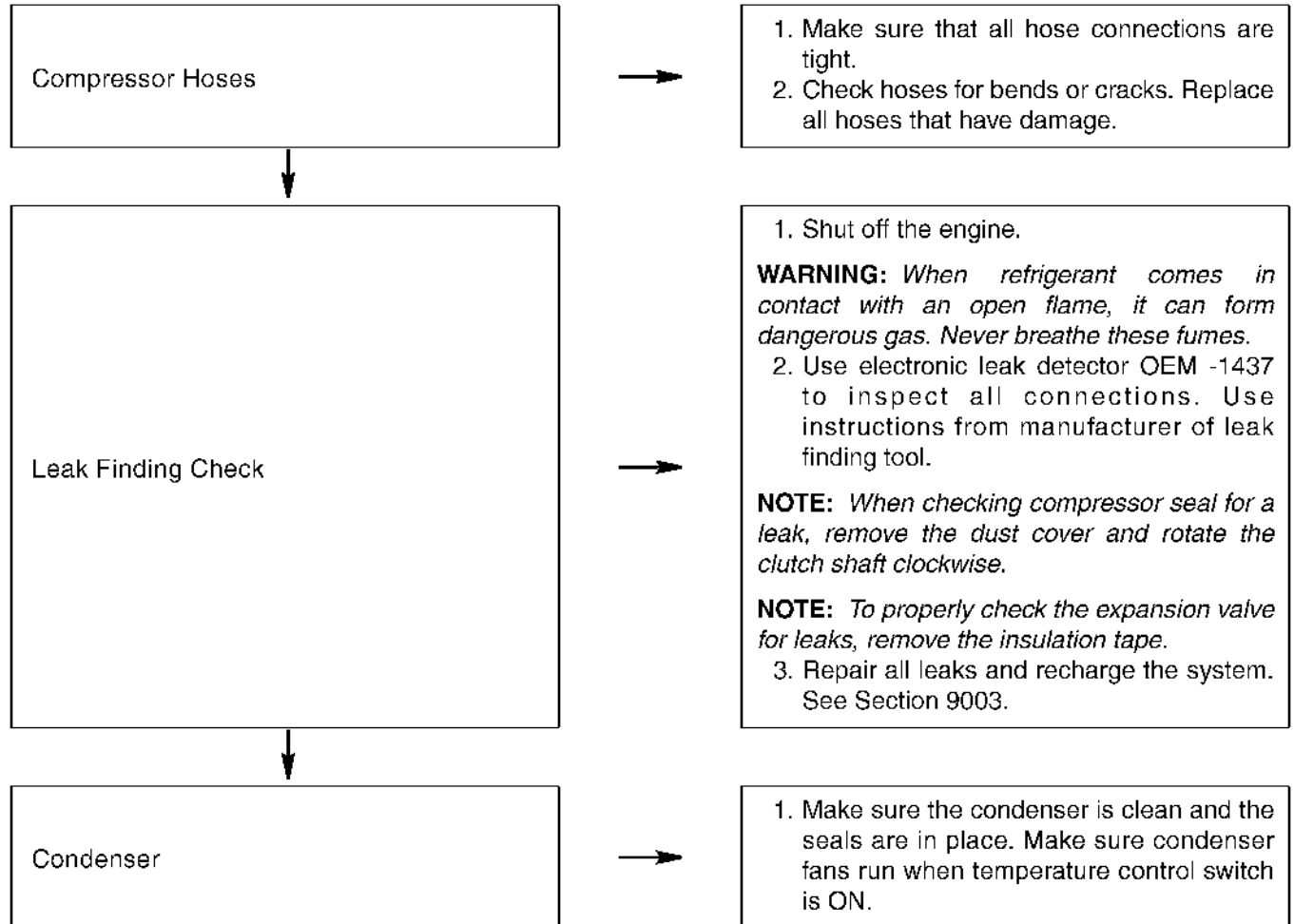

## Expansion Valve Not Operating - Indications:

- A. Discharge air from evaporator warm or cool - not cold.
- B. Condensation or frost on expansion valve outlet.
- C. Inlet end of expansion valve is warm.



1. Expansion valve outlet with condensation or frost is an indication of a restriction in the expansion valve. Replace expansion valve. See Section 9004.
2. Inlet end of expansion valve is warm (not hot), indicating expansion valve is not completely open. If the valve is stuck closed, there will be little or no flow of refrigerant through the valve. Replace expansion valve. See Section 9004.

## AIR CONDITIONER SYSTEM REFRIGERANT RECOVERY

Recovered refrigerant passes through an oil separator and a filter-drier before entering the refrigerant tank. The moisture indicator will turn green when dry refrigerant passes over it.

If possible, run the air conditioning system for ten minutes before starting the recovery process. Turn the system off before proceeding.

### STEP 1



BD03A213

Clean the external surfaces of the compressor and hoses. Remove the caps from the service ports on the suction and pressure hoses.

### STEP 2

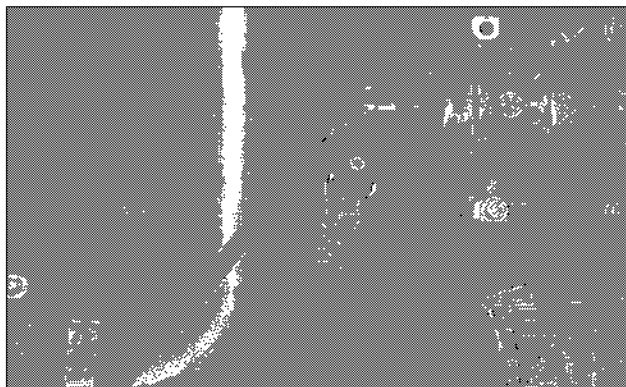

BD03B001

With the charging station manifold gauge valves in the closed position, connect the hoses from the test gauges to the service ports.

Connect the hose from the low pressure gauge to the port on the suction hose. Turn in valve depressor.

Connect the hose from the high pressure gauge to the port on the discharge hose. Turn in valve depressor.

### STEP 3

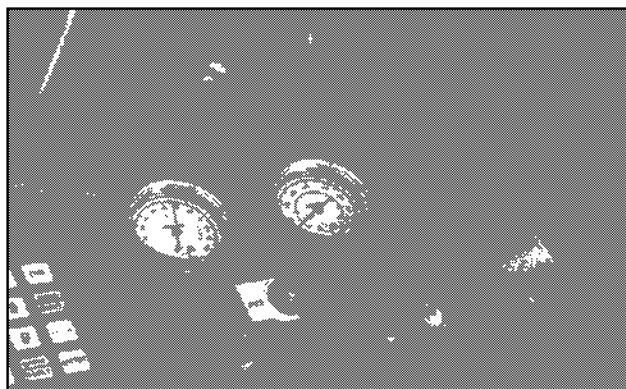

A22114

Open the high and low valves.

### STEP 4

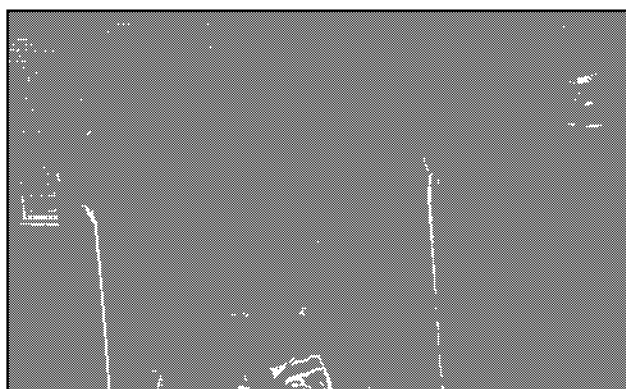

A22107

Make certain the refrigerant tank gas and liquid valves are open.

## COMPRESSOR

### Removal

#### STEP 1

Place the master disconnect switch in the OFF position.

#### STEP 2

Discharge the air conditioning system according to the instructions in Section 9003.

#### STEP 3

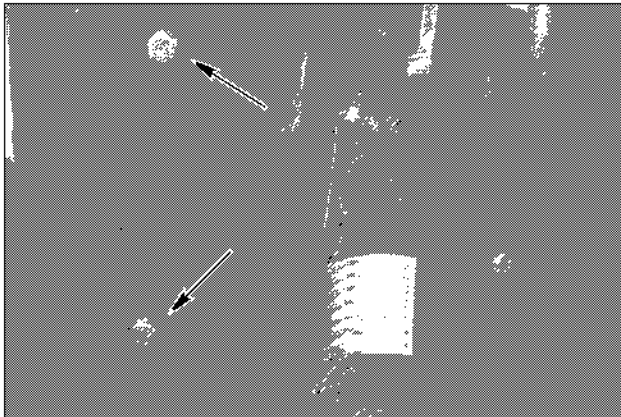

BD06F113

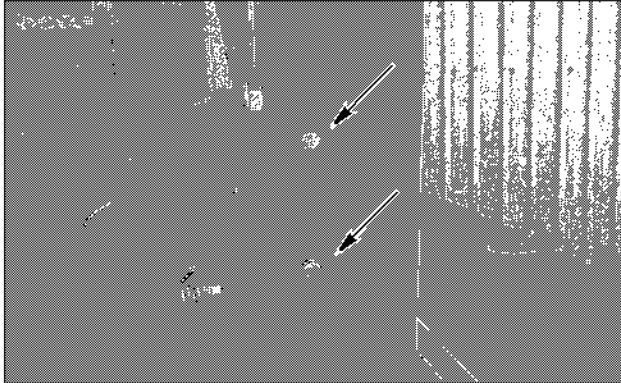

BD06F114

Loosen and remove the four bolts holding the protective shield. Remove the shield.

#### STEP 4

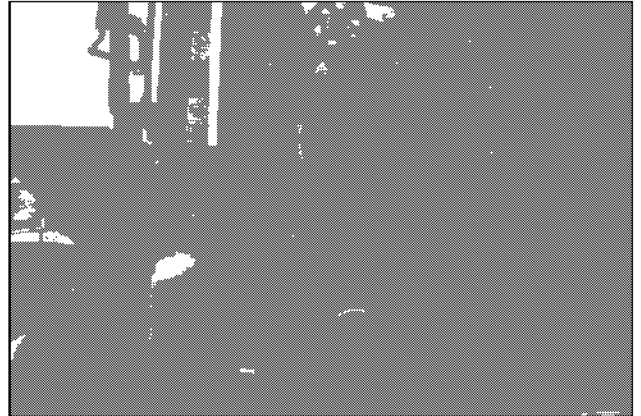

BD06F116

Remove the fan belt.

#### STEP 5

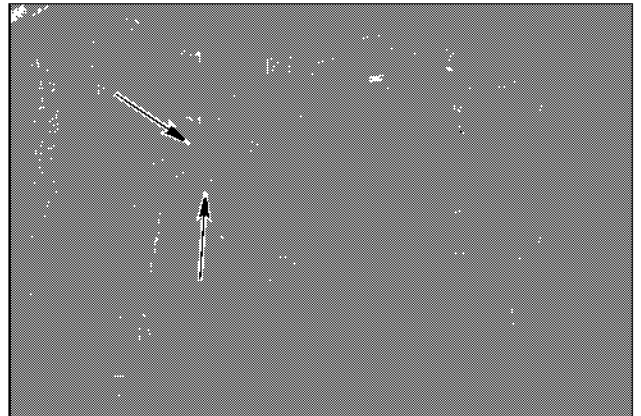

BD06F117

Disconnect the low pressure line from the suction port and the high pressure line from the discharge port on the compressor. Immediately install protective caps on the open ports and lines.

**STEP 59**



BD06G237

Connect the electrical connectors to the thermostat control.

**STEP 60**

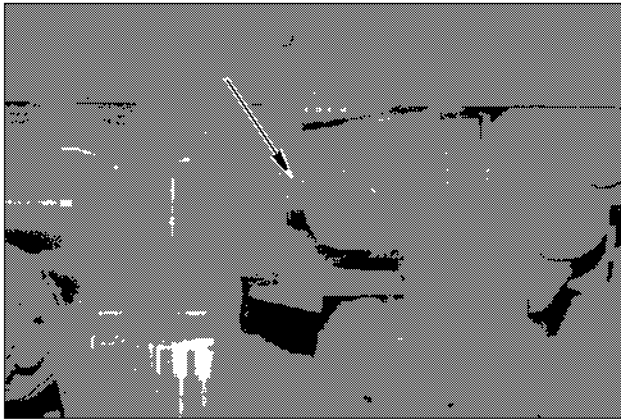

BD06G206

Install the thermostat probe coil and clamp to the evaporator core "cold" tube.

**STEP 61**



BD06G205

1. TRANSMISSION FILTER
2. AIR CONDITIONING HOSES
3. HEATER HOSES

Remove the plugs from the hoses and the caps from the fittings. Install new O-rings in the evaporator fittings, connect the heater and evaporator hoses. Remove and discard identification tags that were used during disassemble.

**STEP 62**

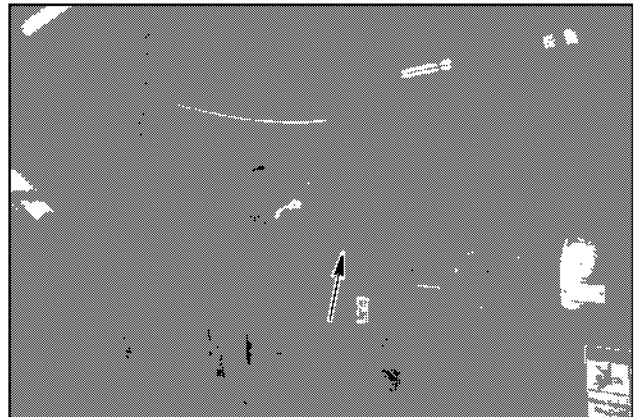

BD06G204

Install the right side cab skirt.

**STEP 63**

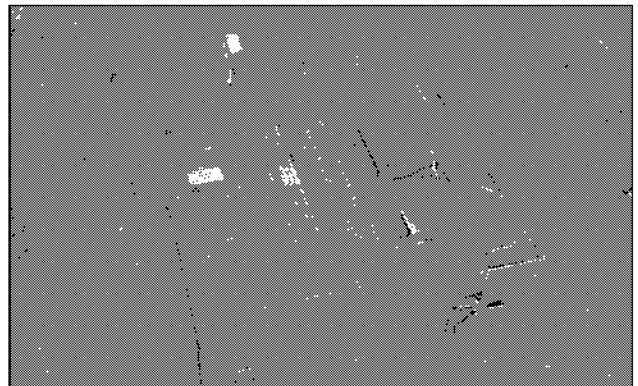

BD06G238

Install the upper PPE on the heater and air conditioning cores.

## SPECIFICATIONS

### Special Torques

Bolts for the Bucket Teeth.....1315 to 1480 Nm (970 to 1090 pound-feet)

## BUCKET TEETH

### Replacement of the Tooth Points

1. Use a hammer and punch to drive the retaining pin (2) for the tooth point (1) out of the tooth shank (3), refer to the illustration on this page.
2. Remove the tooth point (1).
3. Install a new tooth point (1) on the tooth shank (3).
4. Install the retaining pin (2) into the tooth point (1) and tooth shank (3). Make sure the shoulder on the retaining pin is toward the cutting edge. Use a hammer to hit the retaining pin (2) until the retaining pin (2) is even with the outside of the tooth shank (3).

### Replacement of the Bucket Teeth

1. Loosen and remove the nuts (4), hardened washers (5), and bolts (6) from the bucket teeth.

**NOTE:** *If wear of the bolt or nut makes removal difficult, the bolt or nut can be cut off.*

2. Remove the tooth.
3. Install the new tooth on the bucket cutting edge (7).
4. Use new nuts (4), hardened washers (5), and bolts (6) for the tooth being installed.
5. Tighten the nuts (4) to 1315 to 1480 Nm (970 to 1090 pound-feet).

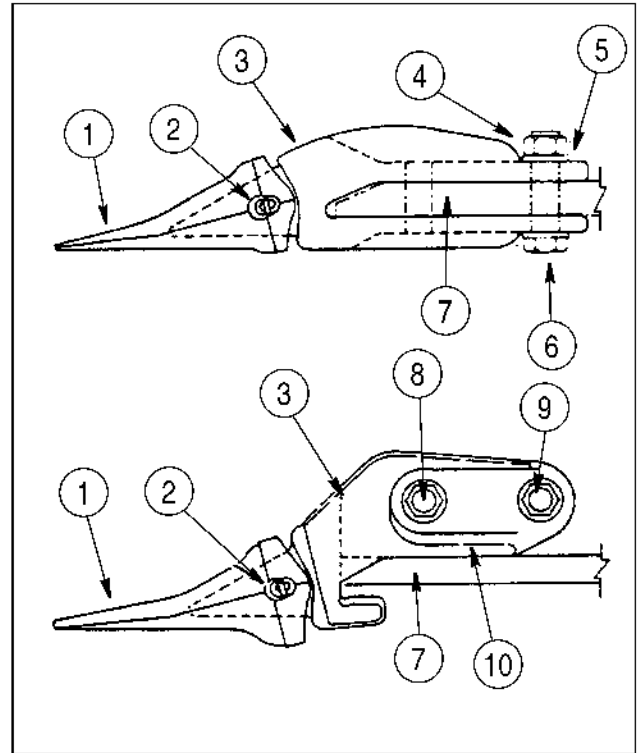

B0740A88J

- |                    |                  |
|--------------------|------------------|
| 1. TOOTH POINT     | 6. BOLT          |
| 2. RETAINING RING  | 7. CUTTING EDGE  |
| 3. TOOTH SHANK     | 8. PLOW BOLT     |
| 4. NUT             | 9. NUT           |
| 5. HARDENED WASHER | 10. CORNER TOOTH |

**BUCKET TEETH ILLUSTRATION**

### Replacement of the Bucket Corner Teeth

1. Loosen and remove the nuts (9) and bolts (8) from the bucket corner teeth (10).

**NOTE:** *If wear of the bolt or nut makes removal difficult, the bolt or nut can be cut off.*

2. Remove the corner tooth (10).
3. Install the new corner tooth (10) on the bucket cutting edge (7).
4. Use new nuts (9) and bolts (8) for the corner tooth being installed.
5. Tighten the nuts (9) to 1315 to 1480 Nm (970 to 1090 pound-feet).

## Install

1. Apply antiseize compound to the inner bores and outer bores of the front frame.
2. Move the machine into alignment with the loader frame (6), refer to the illustration on page 12.
3. Lower the loader frame (6) into alignment with the machine frame.
4. Apply antiseize compound to the pivot pins (3) and (13) that fasten the loader frame (6) to the machine frame.
5. Start the loader frame pivot pin (3), washer (4) and wiper (5).
6. Install the loader frame pivot pin (3) and anchor link pivot pin (13) on one side of the machine.
7. Repeat Steps 5 and 6 for the opposite side of the machine.
8. Install the bolt (1), washer (2) and spacer (14) that secure the pivot pins (3 and 13) to the machine on each side of the machine. Torque the bolt to 325 to 373 Nm (240 to 275 pound feet).
9. Disconnect the chain hoist from the loader frame (6).
10. If the machine is equipped with auxiliary hydraulics, clam hydraulics, or coupler hydraulics, remove the plugs from the tube fittings and the caps from the hoses and make the necessary connections.
11. Connect the hoses and tubing to the bucket cylinders.
12. Fasten the chain hoist to one of the lift cylinders (11 or 15).
13. Raise the piston rod yoke of the lift cylinder (11 or 15) so the piston rod yoke is aligned with the loader frame (6).
14. Install a driver in the piston rod yoke and the loader frame (6).
15. Repeat Steps 12, 13, and 14 for the other lift cylinder (11 or 15).
16. Disconnect the chain hoist from the lift cylinder (11 or 15).
17. Start the engine. Raise the loader frame (6) and roll the bucket all the way forward. Lower the bucket to the floor. Stop the engine.
18. Fasten the chain hoist to the cross member of the loader frame (6).
19. Start the engine and run the engine at low idle.
20. Have another person help you at this time. Move the lift control lever as required to align the piston rod yoke of one of the lift cylinders (11 or 15) with the loader frame (6).

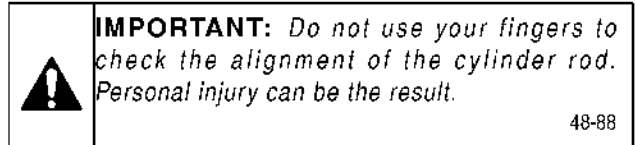

21. Remove the driver and install the pivot pin (7).
22. Install the bolt (9), washer (10), and spacer (8) that fasten the pivot pin (7). Torque the bolt to 325 to 373 Nm (240 to 275 pound feet).
23. Repeat Steps 20, 21, and 22 for the other lift cylinder (11 or 15). Stop the engine.
24. Lubricate the pivot pins with molydisulfide grease.
25. Disconnect the chain hoist from the cross member of the loader frame (6).
26. Start the engine and run the engine at low idle.
27. Slowly extend and retract the cylinders four times to remove air from the hydraulic circuit.
28. If equipped with auxiliary hydraulics, slowly extend and retract the clam cylinders four times to remove air from the auxiliary circuit.
29. Stop the engine, check the level of the oil in the reservoir, and check for oil leaks. Add oil to the reservoir as required.

## Installation

### STEP 26

Check rubber mounts (3 and 4) for deterioration, tears, deformation, or other damage; replace rubber mounts as necessary.

### STEP 27

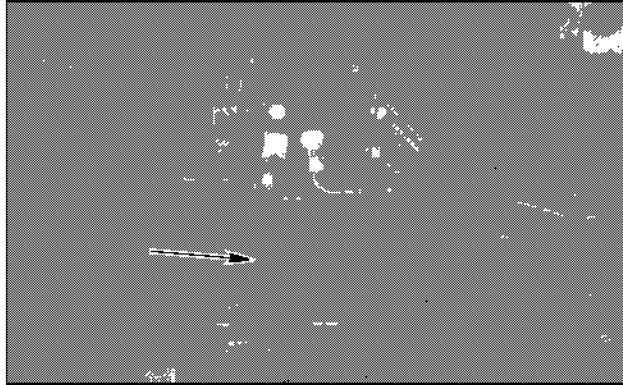

BD01D388

Position cab over rear chassis then put wood blocks under brake valve. Slowly lower cab onto rear chassis making sure that brake valve is positioned so that brake pedal enters into cab. Remove wood blocks as cab is lowered onto brake valve.

### STEP 28

Install washers, bolts, and nuts to secure cab to rear chassis. Tighten bolts to a torque of 773 to 854 Nm (570 to 630 pound feet)

### STEP 29

Disconnect lifting equipment from cab.

### STEP 30

Remove lifting eyes.

### STEP 31

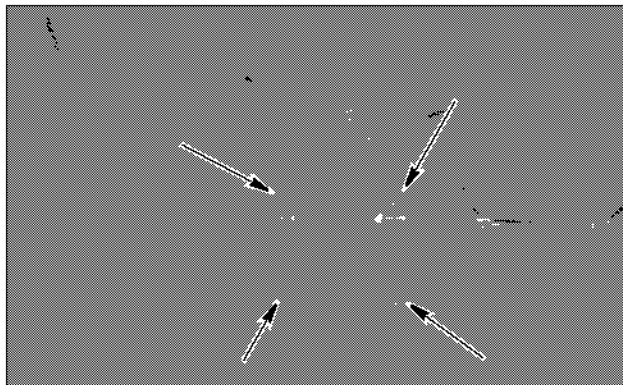

BD06G185

Align mounting holes in brake valve with associated holes in cab or canopy floor. Install hardware to secure brake valve to floor.

### STEP 32

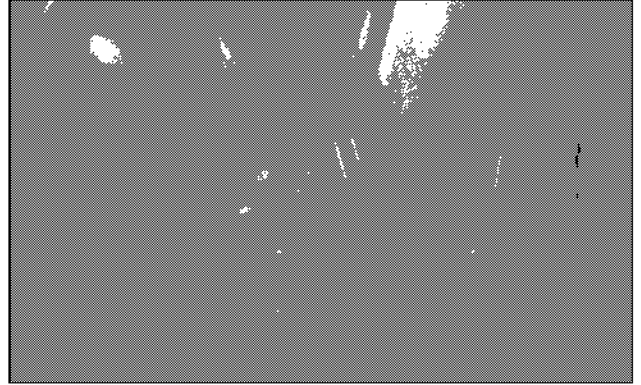

BD06G188

Position floor mat.

### STEP 33

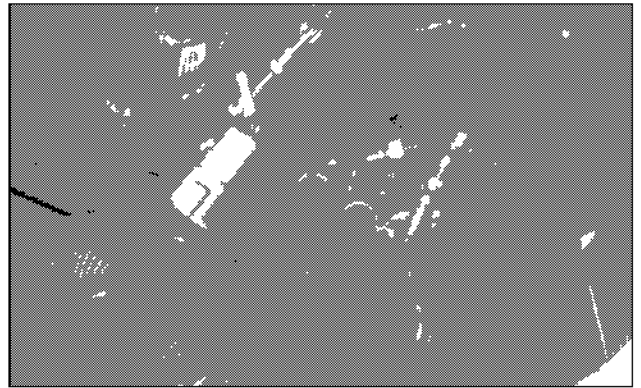

BD06G192

Remove plugs from hoses and caps from fittings. Connect hoses to steering control valve following tags installed during removal. Remove and discard tags.

### STEP 34

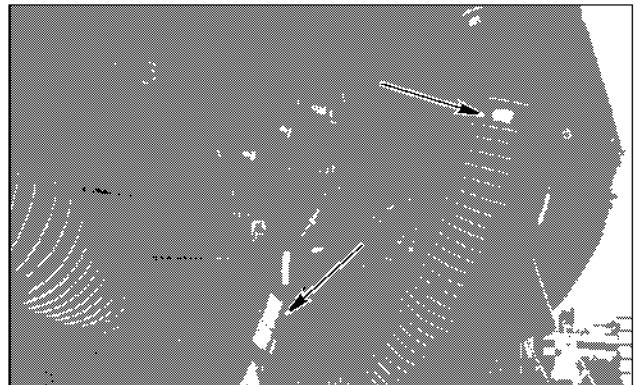

BD06G193

Connect throttle connector and mount air duct.

CLICK HERE TO **DOWNLOAD** THE COMPLETE MANUAL

- Thank you very much for reading the preview of the manual.
- You can download the complete manual from: [www.heydownloads.com](http://www.heydownloads.com) by clicking the link below



- Please note: If there is no response to **CLICKING** the link, please download this PDF first and then click on it.

CLICK HERE TO **DOWNLOAD** THE COMPLETE MANUAL