

**580N**  
**580SN WT**  
**580SN**  
**590SN**  
**Tier 4B (final)**

**Tractor Loader Backhoe**

*580N PIN NGC730186 and above; 580SN WT PIN NGC735098 and above;  
580SN PIN NGC732639 and above; 590SN PIN NGC736228 and above*

**SERVICE MANUAL**

**Part number 48038048**

1<sup>st</sup> edition English

October 2016



CLICK HERE TO **DOWNLOAD** THE COMPLETE MANUAL

- Thank you very much for reading the preview of the manual.
- You can download the complete manual from: [www.heydownloads.com](http://www.heydownloads.com) by clicking the link below



- Please note: If there is no response to CLICKING the link, please download this PDF first and then click on it.

CLICK HERE TO **DOWNLOAD** THE COMPLETE MANUAL

## INTRODUCTION

### 2. Disconnect the battery.

- A. Remove the battery cover bolt (1) hardware.
- B. Slide the battery cover (2) out and away from the machine.

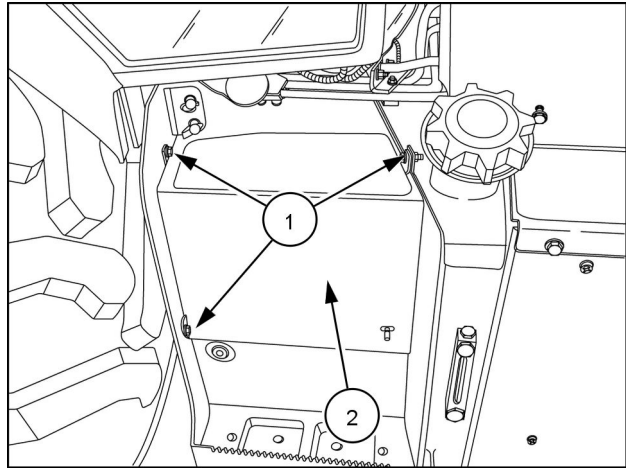

RAIL14TLB1056BA 3

- C. Disconnect the negative battery cable from the negative battery terminal.
- D. Disconnect the positive battery cable from the positive battery terminal.

**NOTE:** The procedure is the same for machines with only one battery.

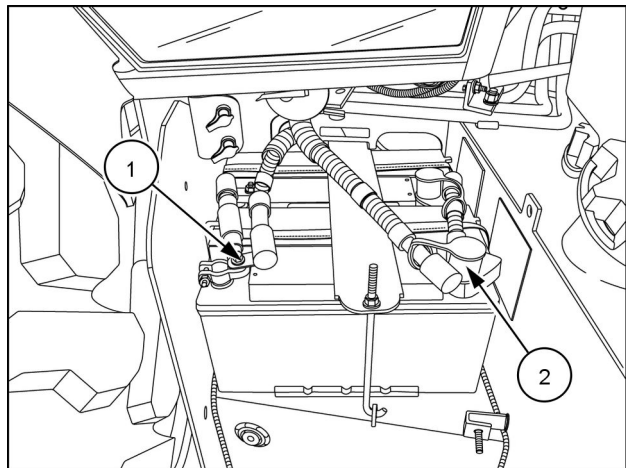

RAIL14TLB1057BA 4

### 3. Disconnect the alternator terminal wires.

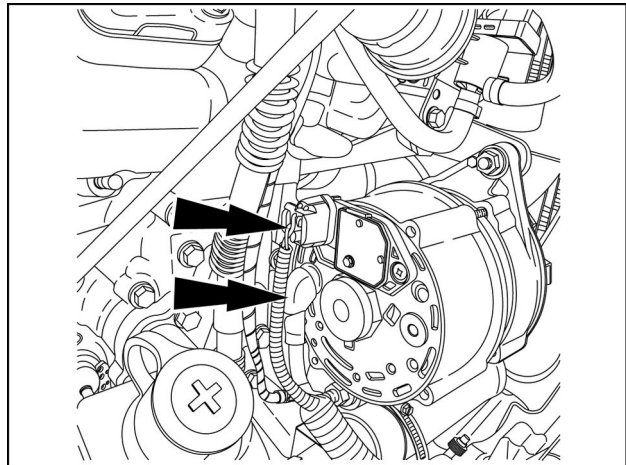

RAPH12FRK0163AA 5

## INTRODUCTION

---

---

### Powershift S-type

Four wheel drive

Total system **20.7 l (21.9 US qt)**

Refill (with or without filter change) **14.3 l (15.1 US qt)**

---

### Powershift H-type

Four wheel drive only

Total system **18.0 L (19.0 US qt)**

Refill (with or without filter change) **11.4 L (12.0 US qt)**

---

**NOTE:** The master brake cylinder receives fluid from the transmission.

---

**NOTE:** CASE AKCELA HY-TRAN® ULTRACTION is an acceptable alternative to CASE AKCELA NEXPLORE™ FLUID.

### Front drive axle - Four-Wheel drive (4WD)

Standard and SCWP specification: **TUTELA TRANSAXLE FLUID SAE 80W-140**

---

Capacity:

Differential **8.6 L (9.1 US qt)**

Each planetary hub **1.0 L (1.1 US qt)**

---

### Rear axle (differential and hubs)

Standard and SCWP specification: **TUTELA TRANSAXLE FLUID SAE 80W-140**

---

Capacity:

**18.6 L (14.4 US qt)**

---

| ID | RPM             | Results                                    |
|----|-----------------|--|
| 1  | 2330 - 2420 RPM | Torque converter or transmission problems. |
| 2  | 2330 - 2420 RPM |  |
| 3  | Below 1880 RPM  |  |
| 4  | Below 1890 RPM  |  |

## Engine - General specification

|   |  |                     |
|---|--|---------------------|
| 590SN FOUR-WHEEL DRIVE (4WD) TIER 4B (FINAL) [NGC736228 - ] |  |                     |
| 590SN TWO-WHEEL DRIVE (2WD) TIER 4B (FINAL) [NGC736228 - ]  |  |                     |
| Model   | Diesel, F5BFL413A*B008, Tier 4B (Final) emissions certified (base engine F5BFL413A*B007) |                     |
| Type  | Four cylinder, turbocharged  |                     |
| Firing order  | 1-3-4-2  |                     |
| Bore and stroke   | 99 mm x 110 mm ( 3.90 in x 4.33 in)  |                     |
| Displacement  | 3.4 l (207.5 in <sup>3</sup> )   |                     |
| Compression ratio   | 17 to 1  |                     |
| Fuel injection  | Direct HPCR  |                     |
| Horsepower - rated at 2200 RPM                              |  |                     |
|   | Gross  | 82 kW (111 Hp)      |
|   | Net with viscous fan   | 81 kW (110 Hp)      |
| Peak torque at 1400 RPM                                     |  |                     |
|   | Gross  | 460 N·m (339 lb ft) |
|   | Net with viscous fan   | 459 N·m (339 lb ft) |
|   | Maximum torque rise  | 29 % ± 5 RPM        |
| Engine speeds   |  |                     |
|   | Rated speed, full load   | 2200 RPM            |
|   | Low idle   | 900 - 1000 RPM      |
|   | High idle, no load   | 2330 - 2430 RPM     |
|   | Converter stall  | 1920 - 2060 RPM     |
|   | Backhoe stall  | 2330 - 2430 RPM     |
|   | Loader stall   | 2330 - 2430 RPM     |
|   | Combine stall  | 1905 - 2045 RPM     |

## Engine - Speeds Stall test check sheet

|   |  |  |
|---|--|--|
| 590SN FOUR-WHEEL DRIVE (4WD) TIER 4B (FINAL) [NGC736228 - ] |  |  |
| 590SN TWO-WHEEL DRIVE (2WD) TIER 4B (FINAL) [NGC736228 - ]  |  |  |

**NOTE:** The following specifications are for engines with more than 50 hours of operation.

**NOTE:** Engine RPM speed is based on the ISO 14396 Cetane number of at least 51 and density between 820 - 845 kg/m<sup>3</sup> (1382 - 1424 lb/yd<sup>3</sup>). Fuel inlet 36.0 - 40.0 °C (96.8 - 104.0 °F).

Results from stall test procedure (fill in values accordingly)

| ID | RPM test valve | Stall test component (specified value)  |
|----|----------------|---|
| 1  |                | Loader hydraulic stall speed ( 2330 - 2430 RPM)                                   |
| 2  |                | Backhoe hydraulic stall speed ( 2330 - 2430 RPM)                                  |
| 3  |                | Torque converter stall speed ( 1920 - 2060 RPM)                                   |
| 4  |                | Combined - loader hydraulic and torque converter - stall speed ( 1905 - 2045 RPM) |

Stall test reference chart

| ID | RPM             | Results   |
|----|-----------------|---|
| 1  | 2330 - 2430 RPM | All systems operating within normal specified RPM values. |
| 2  | 2330 - 2430 RPM |   |
| 3  | 1920 - 2060 RPM |   |
| 4  | 1905 - 2045 RPM |   |

# Contents

---

## Engine - 10

### Fuel filters - 206

#### SERVICE

|                             |   |
|-----------------------------|---|
| Fuel filters                |   |
| Replace .....               | 3 |
| Fuel-water separator filter |   |
| Replace .....               | 4 |

19. Remove the radiator wrapper.

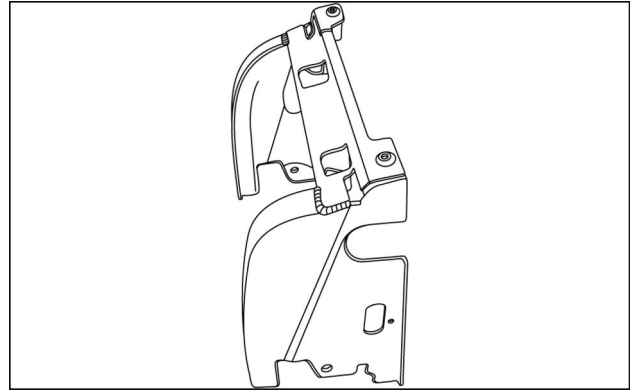

RCPH11TLB028AAM 21

20. Remove the hood strut mounts.

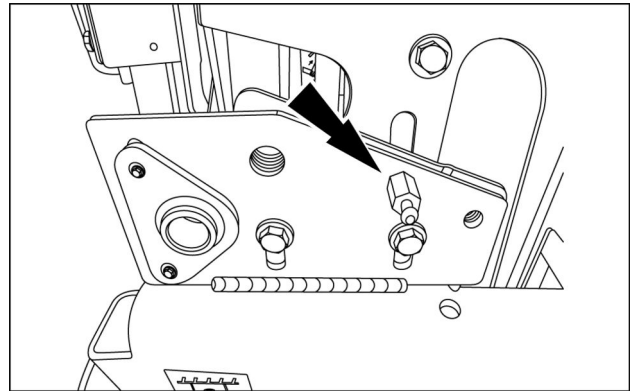

RCPH11TLB029AAM 22

21. Remove the hood hinge plates.

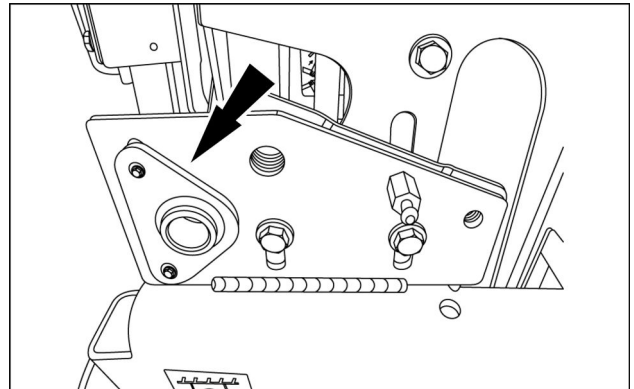

RCPH11TLB029AAM 23

22. Attach a suitable lifting device to the cooling package.

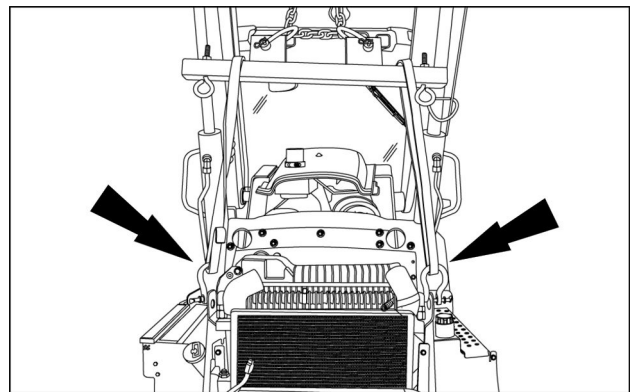

RCPH11TLB030AAM 24

## Selective Catalytic Reduction (SCR) exhaust treatment - Overview

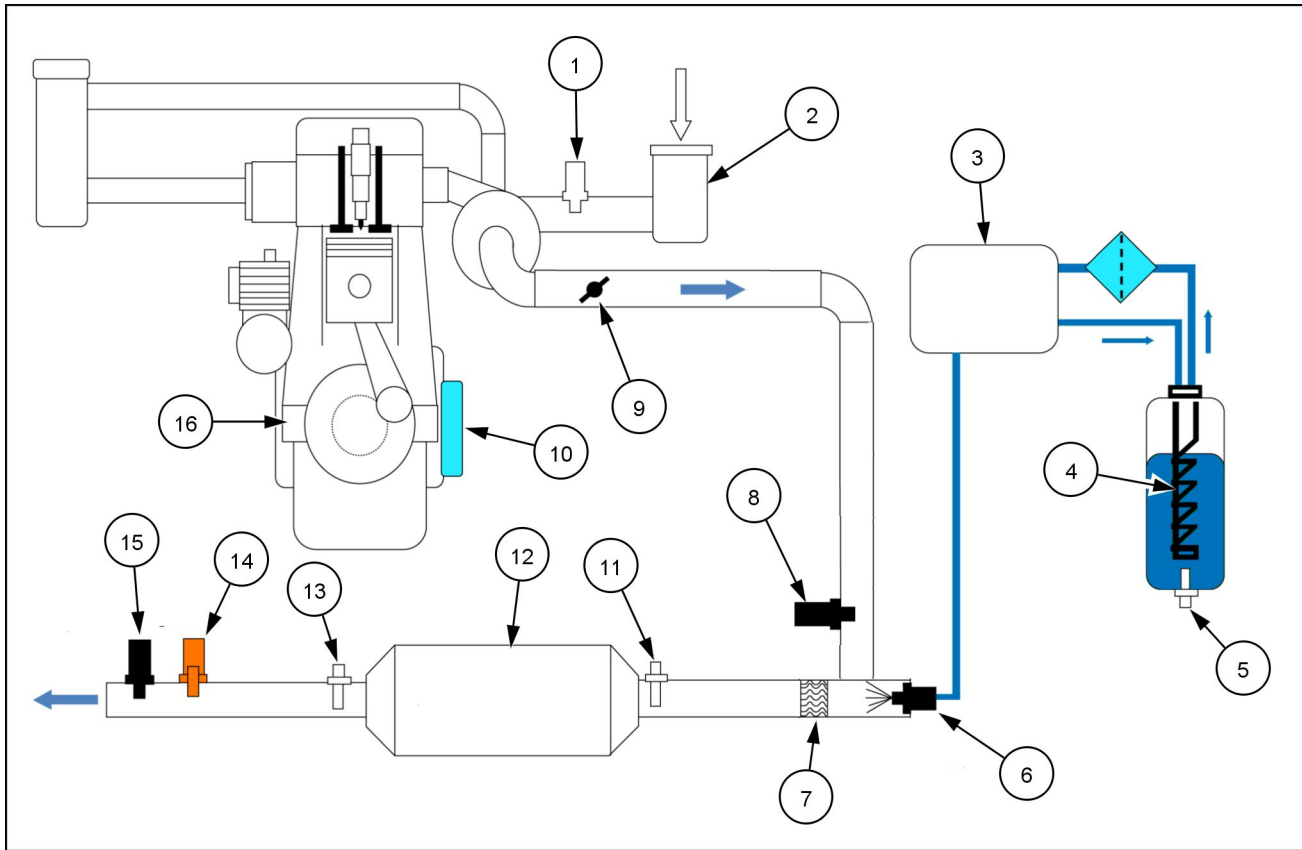

RAIL16TLB0545GA 1

- |  |   |
|--|---|
| (1) Intake air humidity and temperature sensor | (9) Exhaust flap                                  |
| (2) Air filter                                 | (10) Engine Control Unit (ECU)                    |
| (3) Supply module                              | (11) SCR upstream temperature sensor              |
| (4) DEF/AdBlue® level and temperature sensor   | (12) Selective Catalytic Reduction (SCR) catalyst |
| (5) DEF/AdBlue® quality sensor                 | (13) SCR downstream temperature sensor            |
| (6) Dosing module                              | (14) NH <sub>3</sub> sensor                       |
| (7) Mixer                                      | (15) Downstream NO <sub>x</sub> sensor            |
| (8) Upstream NO <sub>x</sub> sensor            | (16) Engine                                       |

The humidity in the intake to the engine (16) affects the emissions in the exhaust stream. The intake air humidity sensor (1) is located in the intake air piping to the engine between the air filter (2) and the intake manifold. The information from this sensor is sent directly to the Engine Control Unit (ECU) (10).

Engine exhaust system temperature is critical to the catalytic reactions that take place in the emissions control components. To quickly increase the catalyst temperature at initial start-up and light operating loads, there is an exhaust flap (9) located in the exhaust stream near the turbocharger. The maximum temperature of the exhaust flap is critical, therefore engine coolant is circulated through the core of this valve. Limiting NO<sub>x</sub> emissions in the exhaust stream is one of the major goals of the emission control system on these engines. The upstream NO<sub>x</sub> sensor (8) is located in the exhaust stream at the inlet to the dosing module (6). The NO<sub>x</sub> sensor transmits data to the ECU via the engine CAN data bus.

DEF/AdBlue® fluid freezes at **-11 °C (12 °F)**. A DEF/AdBlue® fluid level and temperature sensor (4) is installed in the tank and the instrument cluster displays those levels. The DEF/AdBlue® quality sensor (5) monitors the quality of the DEF/AdBlue® fluid.

To precisely control the quantity of DEF/AdBlue® fluid injected from the DEF/AdBlue® tank into the exhaust stream, a DEF/AdBlue® dosing module (6) is integrated in the downpipe. The dosing valve is Pulse Width Modulation (PWM) controlled by the ECU. The ECU determines the amount of DEF/AdBlue® fluid to inject based on inputs from sensors in the exhaust stream. Pressurized DEF/AdBlue® fluid is supplied to the dosing module from the supply module (3) at approximately **9 bar (130 psi)**.

## Power shuttle transmission - General specification

|  |                              |
|--|------------------------------|
| 580N FOUR-WHEEL DRIVE (4WD) TIER 4B (FINAL) [NGC730186 - ]     | Transmission - Power Shuttle |
| 580N TWO-WHEEL DRIVE (2WD) TIER 4B (FINAL) [NGC730186 - ]      | Transmission - Power Shuttle |
| 580SN FOUR-WHEEL DRIVE (4WD) TIER 4B (FINAL) [NGC732639 - ]    | Transmission - Power Shuttle |
| 580SN TWO-WHEEL DRIVE (2WD) TIER 4B (FINAL) [NGC732639 - ]     | Transmission - Power Shuttle |
| 580SN WT FOUR-WHEEL DRIVE (4WD) TIER 4B (FINAL) [NGC735098 - ] | Transmission - Power Shuttle |
| 590SN FOUR-WHEEL DRIVE (4WD) TIER 4B (FINAL) [NGC736228 - ]    | Transmission - Power Shuttle |
| 590SN TWO-WHEEL DRIVE (2WD) TIER 4B (FINAL) [NGC736228 - ]     | Transmission - Power Shuttle |

|                          |                                    |
|--------------------------|------------------------------------|
| Type of transmission oil | MS-1209, Hy-Tran™ Ultra            |
| Clutch disc clearance    | <b>2.3 - 4.3 mm (0.1 - 0.2 in)</b> |

| Capacity - Two wheel drive                    |                            |
|---|----------------------------|
| Total system                                  | <b>18.5 l (19.5 US qt)</b> |
| Refill capacity with or without filter change | <b>16 l (16.9 US qt)</b>   |

| Capacity - Four wheel drive                   |                            |
|---|----------------------------|
| Total system                                  | <b>21 l (22.2 US qt)</b>   |
| Refill capacity with or without filter change | <b>18.5 l (19.5 US qt)</b> |

### Specifications

**NOTE:** All specifications shown were taken from a sampling of new production machines with less than 20 hours. Your figures may differ slightly depending upon the temperature, instrument variables, engine hours, etc.

| Parameter  | Operating Pressure / Temperature                           |
|--|--|
| Output of pump supply  | <b>32 - 68 l/min (8.5 - 18.0 US gpm) at 900 - 2200 RPM</b> |
| Pump supply pressure (4WD)   | <b>1248 - 1551 kPa (181 - 225 psi) at 900 - 2200 RPM</b>   |
| Regulated clutch pressure  | <b>1103 - 1303 kPa (160 - 189 psi) at 900 - 2200 RPM</b>   |
| Torque pressure IN pressure  | <b>48 - 903 kPa (7 - 131 psi) at 900 - 2200 RPM</b>        |
| Torque converter OUT pressure  | <b>0 - 427 kPa (0 - 62 psi) at 900 - 2200 RPM</b>          |
| Lubrication pressure   | <b>40 - 303 kPa (6 - 44 psi) at 900 - 2200 RPM</b>         |
| Transmission oil operating temperature (normal)  | <b>78 - 82 °C (172 - 180 °F)</b>                           |
| Forward/Reverse clutch solenoids   | <b>4.7 ± 10% Ohm at 20 °C (68 °F)</b>                      |
| Four wheel drive solenoid  | <b>6.8 ± 10% Ohm at 20 °C (68 °F)</b>                      |
| Park brake solenoid  | <b>9.8 Ohm at 20 °C (68 °F)</b>                            |
| Differential lock solenoid valve pressure  |  |
| Without differential lock solenoid energized   | <b>0 bar (0 psi)</b>                                       |
| With differential lock solenoid energized (4WD)  | <b>12.5 - 15.5 bar (181.3 - 224.8 psi)</b>                 |
| With differential lock solenoid energized (2WD) and direction control lever in Forward or Reverse position | <b>11 - 13 bar (159.5 - 188.5 psi)</b>                     |
| Park brake check port  | <b>13.5 - 15.5 bar (195.8 - 224.8 psi)</b>                 |

**NOTICE:** Vehicle may move during park brake pressure check. Check park brake pressure from inside of the cab by removing the floor plate.

## Power shuttle transmission - Torque

|  |                              |
|--|------------------------------|
| 580N FOUR-WHEEL DRIVE (4WD) TIER 4B (FINAL) [NGC730186 - ]     | Transmission - Power Shuttle |
| 580N TWO-WHEEL DRIVE (2WD) TIER 4B (FINAL) [NGC730186 - ]      | Transmission - Power Shuttle |
| 580SN FOUR-WHEEL DRIVE (4WD) TIER 4B (FINAL) [NGC732639 - ]    | Transmission - Power Shuttle |
| 580SN TWO-WHEEL DRIVE (2WD) TIER 4B (FINAL) [NGC732639 - ]     | Transmission - Power Shuttle |
| 580SN WT FOUR-WHEEL DRIVE (4WD) TIER 4B (FINAL) [NGC735098 - ] | Transmission - Power Shuttle |
| 590SN FOUR-WHEEL DRIVE (4WD) TIER 4B (FINAL) [NGC736228 - ]    | Transmission - Power Shuttle |
| 590SN TWO-WHEEL DRIVE (2WD) TIER 4B (FINAL) [NGC736228 - ]     | Transmission - Power Shuttle |

|  |                                       |
|--|---------------------------------------|
| Pipe plug in end of four-wheel drive shaft           | <b>30 N·m (265.5 lb in)</b>           |
| Solenoid valve in four-wheel drive valve             | <b>22.0 N·m (194.7 lb in)</b>         |
| Nut for solenoid coils on transmission control valve | <b>7 - 10 N·m (62.0 - 88.5 lb in)</b> |
| Fittings for four-wheel drive clutch tube            | <b>30 N·m (265.5 lb in)</b>           |

## Power shuttle transmission - Test Checking converter in pressure

|  |                              |
|--|------------------------------|
| 580N FOUR-WHEEL DRIVE (4WD) TIER 4B (FINAL) [NGC730186 - ]     | Transmission - Power Shuttle |
| 580N TWO-WHEEL DRIVE (2WD) TIER 4B (FINAL) [NGC730186 - ]      | Transmission - Power Shuttle |
| 580SN FOUR-WHEEL DRIVE (4WD) TIER 4B (FINAL) [NGC732639 - ]    | Transmission - Power Shuttle |
| 580SN TWO-WHEEL DRIVE (2WD) TIER 4B (FINAL) [NGC732639 - ]     | Transmission - Power Shuttle |
| 580SN WT FOUR-WHEEL DRIVE (4WD) TIER 4B (FINAL) [NGC735098 - ] | Transmission - Power Shuttle |
| 590SN FOUR-WHEEL DRIVE (4WD) TIER 4B (FINAL) [NGC736228 - ]    | Transmission - Power Shuttle |
| 590SN TWO-WHEEL DRIVE (2WD) TIER 4B (FINAL) [NGC736228 - ]     | Transmission - Power Shuttle |

### CAS-1804 Pressure Fitting Kit

**NOTE:** See *Power shuttle transmission - Tool connection 2 Wheel drive port identification (21.112)* or *Power shuttle transmission - Tool connection 4 Wheel drive port identification (21.112)* for test port locations.

1. Engage the parking brake.
2. Start the engine. The oil should be at normal operating temperatures.
3. Connect a **14 bar (200 psi)** to test port 6 (**A**) for 2WD or 4WD machines.
4. Place transmission controls in neutral.
5. Monitor the gauge and record the values for low idle, see **Power shuttle transmission - Pressure test 2 Wheel drive, test one engine at idle, 900 to 1100 RPM (21.112)** or **Power shuttle transmission - Pressure test 4 Wheel drive, test one engine at idle, 900 to 1100 RPM (21.112)**.
6. Monitor the gauge and record the values for full throttle, see **Power shuttle transmission - Pressure test 2 Wheel drive, test two engine at 2200 RPM (21.112)** or **Power shuttle transmission - Pressure test 4 Wheel drive, test two engine at 2200 RPM (21.112)**.

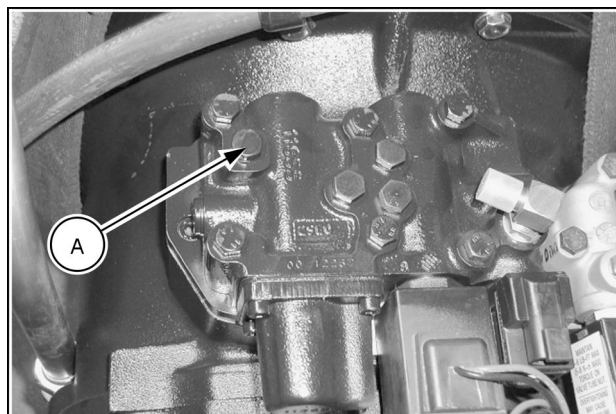

RCPH11TLB015BAL 1

## Transmission housing - Disassemble Shift rods and shift forks

|  |                              |
|--|------------------------------|
| 580N FOUR-WHEEL DRIVE (4WD) TIER 4B (FINAL) [NGC730186 - ]     | Transmission - Power Shuttle |
| 580N TWO-WHEEL DRIVE (2WD) TIER 4B (FINAL) [NGC730186 - ]      | Transmission - Power Shuttle |
| 580SN FOUR-WHEEL DRIVE (4WD) TIER 4B (FINAL) [NGC732639 - ]    | Transmission - Power Shuttle |
| 580SN TWO-WHEEL DRIVE (2WD) TIER 4B (FINAL) [NGC732639 - ]     | Transmission - Power Shuttle |
| 580SN WT FOUR-WHEEL DRIVE (4WD) TIER 4B (FINAL) [NGC735098 - ] | Transmission - Power Shuttle |
| 590SN FOUR-WHEEL DRIVE (4WD) TIER 4B (FINAL) [NGC736228 - ]    | Transmission - Power Shuttle |
| 590SN TWO-WHEEL DRIVE (2WD) TIER 4B (FINAL) [NGC736228 - ]     | Transmission - Power Shuttle |

1. If disassembly is required, remove the roll pins and separate the shift forks from the shift rods. Make sure that you remember how the parts are assembled and which parts go together. The forks are the only parts that are not interchangeable. Inspect all parts for burrs and excessive wear. Assembly is the reverse of disassembly.

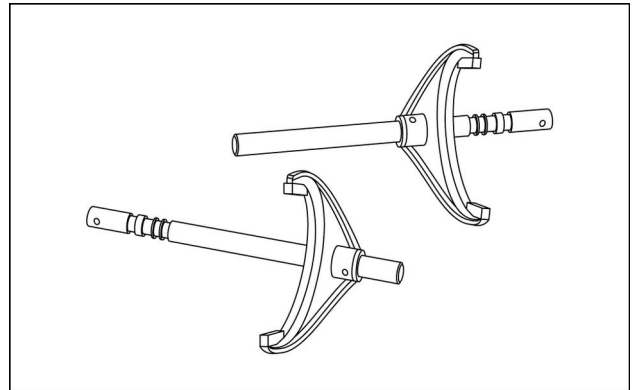

RCPH10TLB944AAL 1

### Next operation:

**Transmission housing - Assemble (21.112)**

## Powershift transmission - General specification S-type

|  |  |
|--|--|
| 580N FOUR-WHEEL DRIVE (4WD) TIER 4B (FINAL) [NGC730186 - ]     | Transmission - Powershift transmission |
| 580N TWO-WHEEL DRIVE (2WD) TIER 4B (FINAL) [NGC730186 - ]      | Transmission - Powershift transmission |
| 580SN FOUR-WHEEL DRIVE (4WD) TIER 4B (FINAL) [NGC732639 - ]    | Transmission - Powershift transmission |
| 580SN TWO-WHEEL DRIVE (2WD) TIER 4B (FINAL) [NGC732639 - ]     | Transmission - Powershift transmission |
| 580SN WT FOUR-WHEEL DRIVE (4WD) TIER 4B (FINAL) [NGC735098 - ] | Transmission - Powershift transmission |
| 590SN FOUR-WHEEL DRIVE (4WD) TIER 4B (FINAL) [NGC736228 - ]    | Transmission - Powershift transmission |
| 590SN TWO-WHEEL DRIVE (2WD) TIER 4B (FINAL) [NGC736228 - ]     | Transmission - Powershift transmission |

**NOTE:** All transmission pressures are to measured with an oil temperature of 80 °C (176 °F)

| Item                                   | Pressure Minimum/Maximum  |
|--|---|
| Control valve supply pressure          | <b>13 bar (189 psi) @ 900 RPM</b><br><b>17 bar (247 psi) @ 2400 RPM</b> |
| Forward or reverse clutch pressure     | <b>12 bar (174 psi) @ 900 RPM</b><br><b>16 bar (232 psi) @ 2400 RPM</b> |
| 1N2, 3N4, 1st, 2nd, 3rd, 4th, HDL, 4WD | <b>13 bar (189 psi) @ 900 RPM</b><br><b>17 bar (247 psi) @ 2400 RPM</b> |
| Torque converter inlet                 | <b>1.5 bar (22 psi) @ 900 RPM</b><br><b>10 bar (145 psi) @ 900 RPM</b>  |
| Brake booster port                     | <b>13 bar (189 psi) @ 900 RPM</b><br><b>17 bar (247 psi) @ 2400 RPM</b> |

## Powershift transmission - Special tools

|  |  |
|--|--|
| 580N FOUR-WHEEL DRIVE (4WD) TIER 4B (FINAL) [NGC730186 - ]     | Transmission - Powershift transmission |
| 580N TWO-WHEEL DRIVE (2WD) TIER 4B (FINAL) [NGC730186 - ]      | Transmission - Powershift transmission |
| 580SN FOUR-WHEEL DRIVE (4WD) TIER 4B (FINAL) [NGC732639 - ]    | Transmission - Powershift transmission |
| 580SN TWO-WHEEL DRIVE (2WD) TIER 4B (FINAL) [NGC732639 - ]     | Transmission - Powershift transmission |
| 580SN WT FOUR-WHEEL DRIVE (4WD) TIER 4B (FINAL) [NGC735098 - ] | Transmission - Powershift transmission |
| 590SN FOUR-WHEEL DRIVE (4WD) TIER 4B (FINAL) [NGC736228 - ]    | Transmission - Powershift transmission |
| 590SN TWO-WHEEL DRIVE (2WD) TIER 4B (FINAL) [NGC736228 - ]     | Transmission - Powershift transmission |

### CAS-1804 Pressure Fitting Kit



RCPH11TLB020BAL 1

Transmission - Powershift transmission

|    |                  |    |                  |
|----|------------------|----|------------------|
| 19 | Clutch piston    | 39 | Teflon seal ring |
| 20 | Teflon seal ring | 40 | Snap ring        |

60. Remove the snap ring.

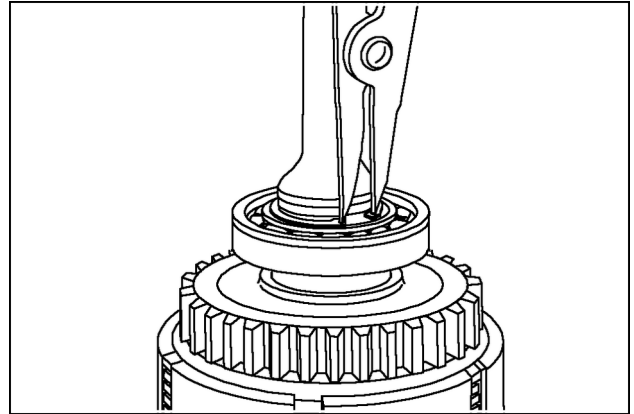

RCPH10TLB111AAL 59

61. Install a bearing puller under the gear as shown. Do not install the bearing puller between the gear and the bearing. Insert a shaft protector between the puller and the end of the input shaft.

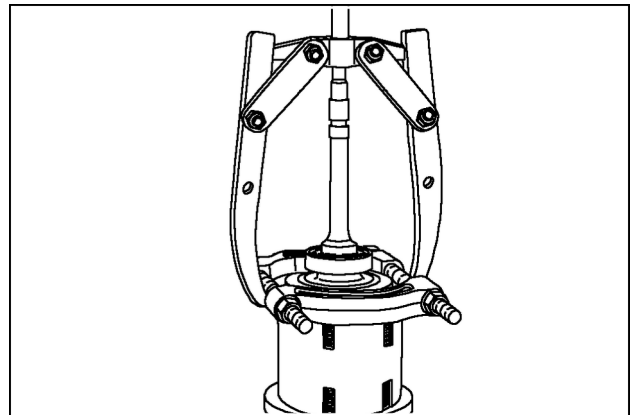

RCPH10TLB112AAL 60

62. Remove the bearing.

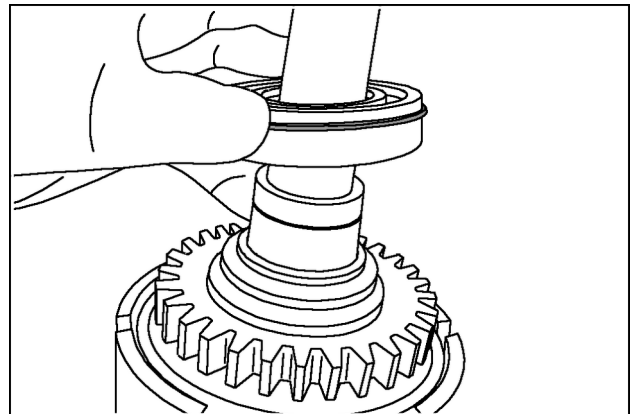

RCPH10TLB113AAL 61

63. Remove the spacer.

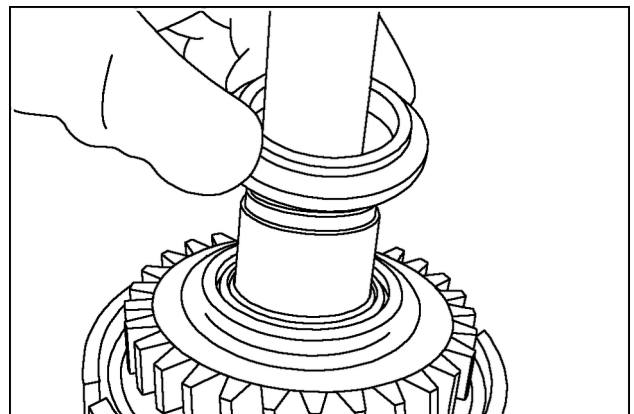

RCPH10TLB114AAL 62

16. Subtract **1.8 mm** from X. The result is the shim thickness required.  
 $(X - 1.8 \text{ mm}) = \text{the required shim thickness.}$

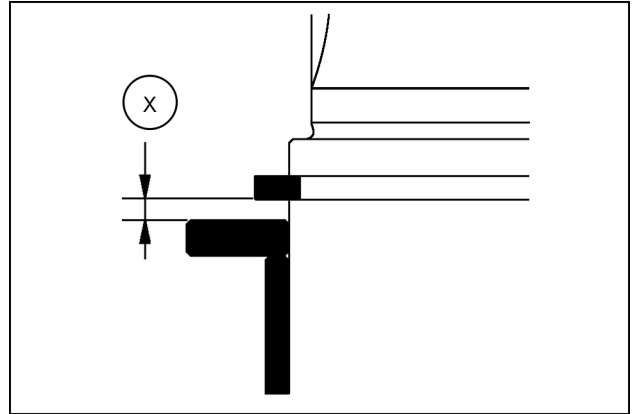

RCPH10TLB241AAL 16

17. Select the shim thickness value among the range of available shims.

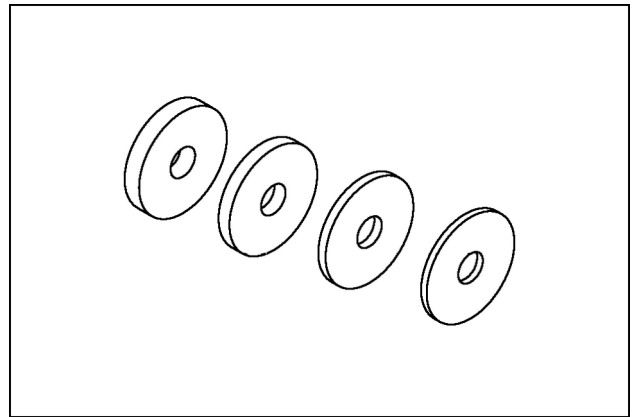

RCPH10TLB242AAL 17

**NOTE:** Verify that there is a stroke of **1.700 mm (0.067 in)** to **1.900 mm (0.075 in)** after shims are installed.

18. Remove the lock ring and washer from the shaft.

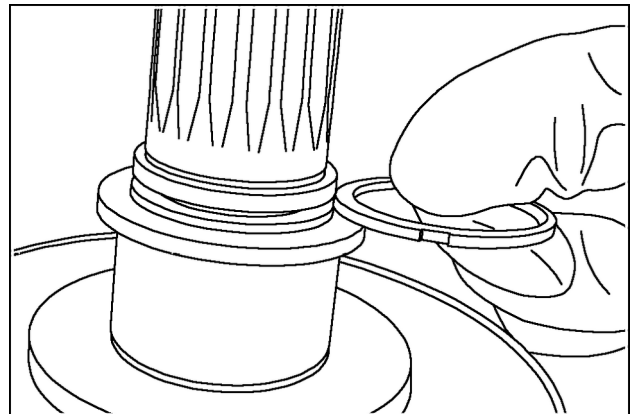

RCPH10TLB243AAL 18

19. Install the bellville washers, the washer must be installed with the outer rings touching and the inner rings have a gap.

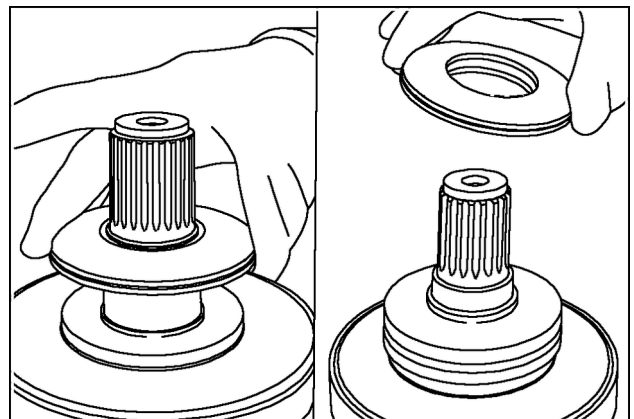

RCPH10TLB302AAL 19

166. Install the 380001928 pusher over the expander/protector and slide the sealing ring until it reaches the groove in the shaft. Remove the pusher and expander/protector from the shaft.

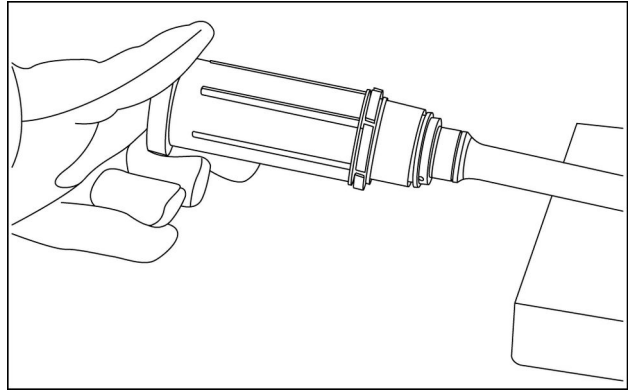

RCPH10TLB844AAL 164

167. Install the end of the 380001427 seal compressor with the deep chamfer onto the shaft and over the sealing ring. Use a back and forth twisting motion to allow the seal compressor to slip over the top of the sealing ring and seat the sealing ring into the groove. Be careful not to damage the sealing ring. After the sealing ring is seated in the groove, remove the seal compressor from the shaft.

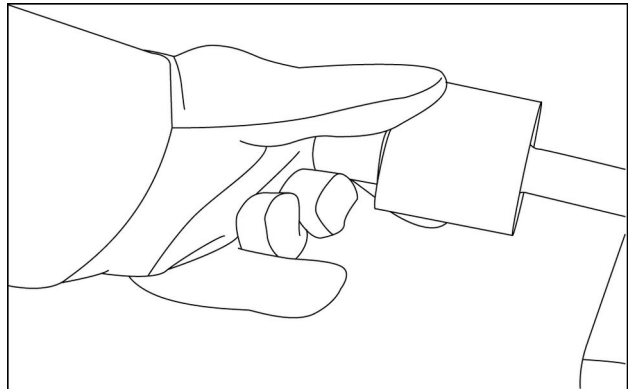

RCPH10TLB845AAL 165

168. Turn the seal compressor around and slide the end with the narrow chamfer over the shaft and over the sealing ring. Leave the seal compressor in place for **15 min** until the sealing ring has cooled and is properly sized and seated in the groove. After the sealing ring has cooled, remove the seal compressor from the shaft.

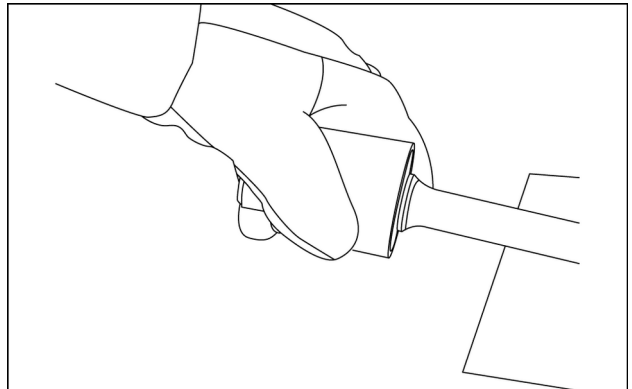

RCPH10TLB846AAL 166

169. Install the bearing and snap ring on the PTO shaft.

170. Put the PTO shaft into the transmission.

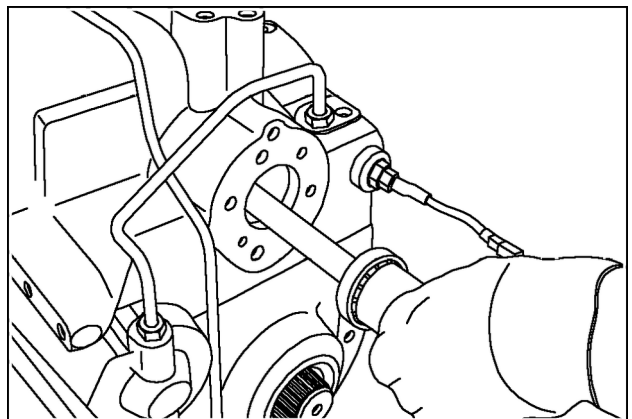

RCPH10TLB256AAL 167

## Powershift transmission - Testing Machine will not move, H-type and S-type

|  |  |
|--|--|
| 580N FOUR-WHEEL DRIVE (4WD) TIER 4B (FINAL) [NGC730186 - ]     | Transmission - Powershift transmission |
| 580N TWO-WHEEL DRIVE (2WD) TIER 4B (FINAL) [NGC730186 - ]      | Transmission - Powershift transmission |
| 580SN FOUR-WHEEL DRIVE (4WD) TIER 4B (FINAL) [NGC732639 - ]    | Transmission - Powershift transmission |
| 580SN TWO-WHEEL DRIVE (2WD) TIER 4B (FINAL) [NGC732639 - ]     | Transmission - Powershift transmission |
| 580SN WT FOUR-WHEEL DRIVE (4WD) TIER 4B (FINAL) [NGC735098 - ] | Transmission - Powershift transmission |
| 590SN FOUR-WHEEL DRIVE (4WD) TIER 4B (FINAL) [NGC736228 - ]    | Transmission - Powershift transmission |
| 590SN TWO-WHEEL DRIVE (2WD) TIER 4B (FINAL) [NGC736228 - ]     | Transmission - Powershift transmission |

| Test N°1                             |   |
|--------------------------------------|---|
| <b>Test Point</b>                    | <b>Check</b><br>Verify the transmission oil level. Refer to <b>Powershift transmission - General specification (21.113)</b> . Refer to the Operator's Manual for the proper transmission fluid level.             |
| <b>Expected Result</b>               | <b>Result</b><br>The oil level is correct. Go to the next step.   |
| <b>Other Result (Possible Cause)</b> | <b>Action</b><br>The transmission oil level is not correct. Check for leaks in the system. Fill the transmission oil to the proper level. Refer to the Operator's Manual for the proper transmission fluid level. |

| Test N°2                             |  |
|--------------------------------------|--|
| <b>Test Point</b>                    | <b>Check</b><br>Does the SAHR parking brake release?   |
| <b>Expected Result</b>               | <b>Result</b><br>Yes, the SAHR parking brake does release. Go to the next step.  |
| <b>Other Result (Possible Cause)</b> | <b>Action</b><br>No, the SAHR parking brake does not release. Check the transmission oil pressure and the electrical supply to the solenoid. Repair as required. |

| Test N°3                             |   |
|--------------------------------------|---|
| <b>Test Point</b>                    | <b>Check</b><br>Check for a broken universal joint or a broken drive shaft.                         |
| <b>Expected Result</b>               | <b>Result</b><br>The drive shaft and the universal joint are free from damage. Go to the next step. |
| <b>Other Result (Possible Cause)</b> | <b>Action</b><br>The drive shaft or the universal joint is damaged. Repair as required.             |

| Test N°4                             |  |
|--------------------------------------|--|
| <b>Test Point</b>                    | <b>Condition</b><br>Raise the rear wheels off the ground.<br><b>Check</b><br>Verify that the drive shaft turns when the transmission directional control lever (FNR) is moved into forward or reverse. |
| <b>Expected Result</b>               | <b>Result</b><br>The drive shaft turns when the transmission directional control lever (FNR) is moved into forward or reverse. Go to the next step.  |
| <b>Other Result (Possible Cause)</b> | <b>Action</b><br>The drive shaft does not turn. Check the electrical connections to the transmission. Verify that there is power to the clutch solenoids. Check fuse F-024.                            |

| Test N°5          |  |
|-------------------|--|
| <b>Test Point</b> | <b>Check</b><br>Check the transmission pressure and the pump flow. |

Transmission - Powershift transmission external controls

| <b>Gear</b> | <b>1N2</b>                            | <b>1st</b>                            | <b>2nd</b>                            | <b>3N4</b>                            | <b>3rd</b>                            | <b>4th</b>                            |
|-------------|---------------------------------------|---------------------------------------|---------------------------------------|---------------------------------------|---------------------------------------|---------------------------------------|
| Neutral     | 13 - 17 bar<br>(188.5 -<br>246.5 psi) | 0 bar (0.0 psi)                       | 13 - 17 bar<br>(188.5 -<br>246.5 psi) | 13 - 17 bar<br>(188.5 -<br>246.5 psi) | 0 bar (0.0 psi)                       | 13 - 17 bar<br>(188.5 -<br>246.5 psi) |
| 1st         | 13 - 17 bar<br>(188.5 -<br>246.5 psi) | 13 - 17 bar<br>(188.5 -<br>246.5 psi) | 0 bar (0.0 psi)                       | 13 - 17 bar<br>(188.5 -<br>246.5 psi) | 0 bar (0.0 psi)                       | 13 - 17 bar<br>(188.5 -<br>246.5 psi) |
| 2nd         | 0 bar (0.0 psi)                       | 0 bar (0.0 psi)                       | 13 - 17 bar<br>(188.5 -<br>246.5 psi) | 13 - 17 bar<br>(188.5 -<br>246.5 psi) | 0 bar (0.0 psi)                       | 13 - 17 bar<br>(188.5 -<br>246.5 psi) |
| 3rd         | 13 - 17 bar<br>(188.5 -<br>246.5 psi) | 0 bar (0.0 psi)                       | 13 - 17 bar<br>(188.5 -<br>246.5 psi) | 13 - 17 bar<br>(188.5 -<br>246.5 psi) | 13 - 17 bar<br>(188.5 -<br>246.5 psi) | 0 bar (0.0 psi)                       |
| 4th         | 13 - 17 bar<br>(188.5 -<br>246.5 psi) | 0 bar (0.0 psi)                       | 13 - 17 bar<br>(188.5 -<br>246.5 psi) | 0 bar (0.0 psi)                       | 0 bar (0.0 psi)                       | 13 - 17 bar<br>(188.5 -<br>246.5 psi) |

37. Tap lightly on the end plate to move the end plate down so that there is clearance between the snap ring and the end plate.

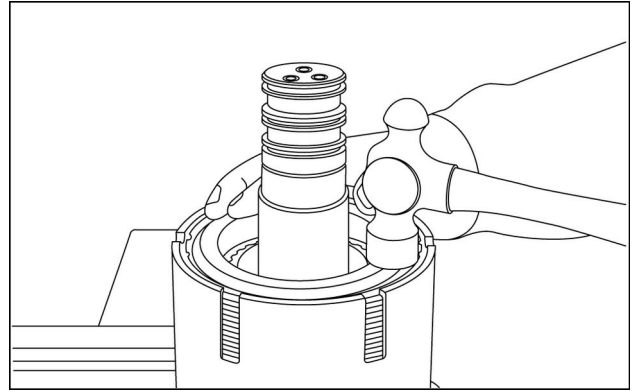

RCPH10TLB932AAL 35

38. Remove the snap ring.

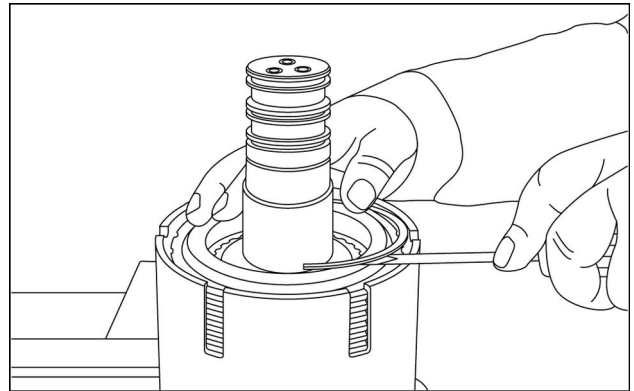

RCPH10TLB931AAL 36

39. Use pry bars to lift the end plate evenly. Remove the end plate.

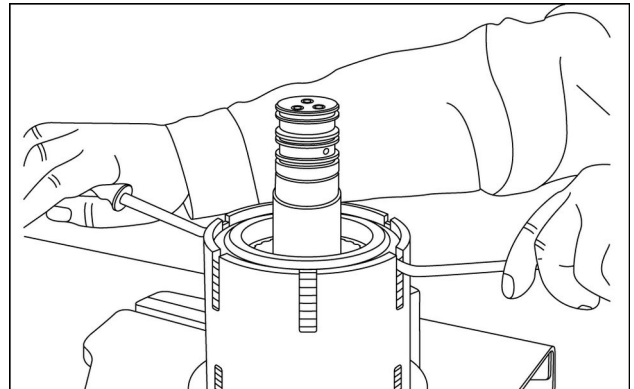

RCPH10TLB933AAL 37

40. Remove the roll pin.

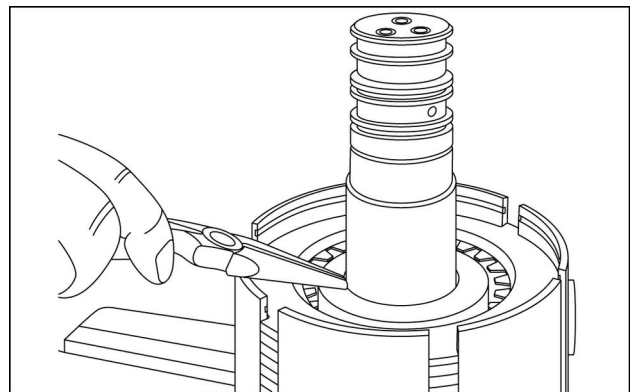

RCPH10TLB934AAL 38

## Transmission drive and driven shafts - Adjust Backlash adjustment

|  |                              |
|--|------------------------------|
| 580N FOUR-WHEEL DRIVE (4WD) TIER 4B (FINAL) [NGC730186 - ]     | Transmission - Power Shuttle |
| 580N TWO-WHEEL DRIVE (2WD) TIER 4B (FINAL) [NGC730186 - ]      | Transmission - Power Shuttle |
| 580SN FOUR-WHEEL DRIVE (4WD) TIER 4B (FINAL) [NGC732639 - ]    | Transmission - Power Shuttle |
| 580SN TWO-WHEEL DRIVE (2WD) TIER 4B (FINAL) [NGC732639 - ]     | Transmission - Power Shuttle |
| 580SN WT FOUR-WHEEL DRIVE (4WD) TIER 4B (FINAL) [NGC735098 - ] | Transmission - Power Shuttle |
| 590SN FOUR-WHEEL DRIVE (4WD) TIER 4B (FINAL) [NGC736228 - ]    | Transmission - Power Shuttle |
| 590SN TWO-WHEEL DRIVE (2WD) TIER 4B (FINAL) [NGC736228 - ]     | Transmission - Power Shuttle |

1. Install the thrust washer and snap ring.

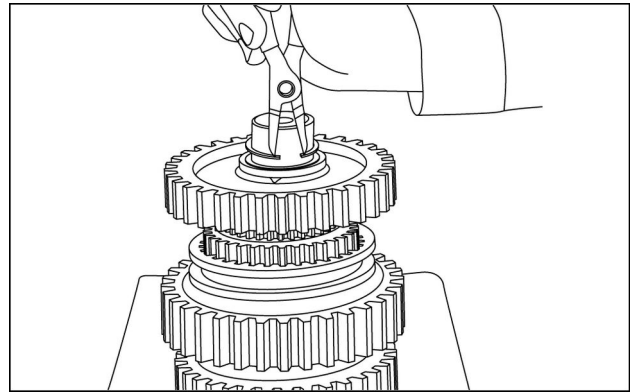

RCPH10TLB775AAL 1

2. Use a feeler gauge and measure the backlash between the gear and the thrust washer. Record this measurement (a). Subtract the recorded measurement (a) from **0.2000 - 0.4200 mm (0.0079 - 0.0165 in)**
  - (a) from **0.2000 - 0.4200 mm (0.0079 - 0.0165 in)**
  - (b). Select the shim(s) required (c). Example: Use **0.8300 mm (0.0327 in) ± 0.1100 mm (0.0043 in)** shim
  - (s).

a. **1.1400 mm (0.0449 in)**

b. **-0.3100 mm (-0.0122 in)**

c. **0.8300 mm (0.0327 in)**

3. Remove the snap ring and the thrust washer.

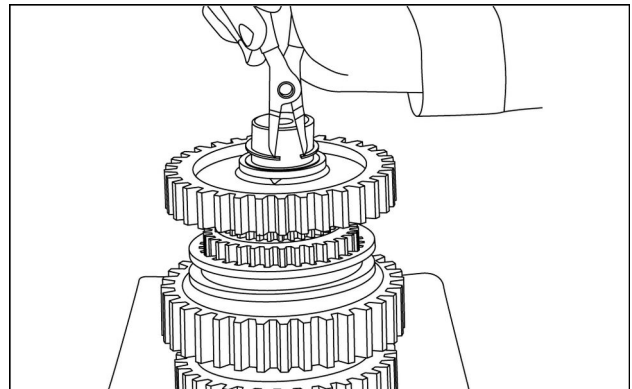

RCPH10TLB775AAL 2

Transmission - Powershift transmission internal components

|    |                     |    |                     |
|----|---------------------|----|---------------------|
| 1  | Bearing             | 21 | Split pin           |
| 2  | Bearing             | 22 | Split pin           |
| 3  | Teflon seal         | 23 | Teflon seal ring    |
| 4  | Snap ring           | 24 | O-ring              |
| 5  | Bearing             | 25 | Clutch piston       |
| 6  | Spacer              | 26 | Sleeve              |
| 7  | Needle cage         | 27 | Spring              |
| 8  | Gear                | 28 | Lock washer         |
| 9  | Retaining plate     | 29 | Snap ring           |
| 10 | Lock ring           | 30 | Clutch plates       |
| 11 | Thrust plate        | 31 | Clutch drive plates |
| 12 | Clutch drive plates | 32 | Thrust plate        |
| 13 | Clutch plates       | 33 | Lock ring           |
| 14 | Snap ring           | 34 | Retaining plate     |
| 15 | Lock washer         | 35 | Gear                |
| 16 | Spring              | 36 | Needle cage         |
| 17 | Sleeve              | 37 | Retaining plate     |
| 18 | Clutch piston       | 38 | Bearing             |
| 19 | Teflon seal ring    | 39 | Snap ring           |
| 20 | O-ring              | 40 | Teflon seal ring    |

## Shaft assemblies - Assemble S-type (SPS Power Synchro) - shafts A - D

|  |  |
|--|--|
| 580N FOUR-WHEEL DRIVE (4WD) TIER 4B (FINAL) [NGC730186 - ]     | Transmission - Powershift transmission |
| 580N TWO-WHEEL DRIVE (2WD) TIER 4B (FINAL) [NGC730186 - ]      | Transmission - Powershift transmission |
| 580SN FOUR-WHEEL DRIVE (4WD) TIER 4B (FINAL) [NGC732639 - ]    | Transmission - Powershift transmission |
| 580SN TWO-WHEEL DRIVE (2WD) TIER 4B (FINAL) [NGC732639 - ]     | Transmission - Powershift transmission |
| 580SN WT FOUR-WHEEL DRIVE (4WD) TIER 4B (FINAL) [NGC735098 - ] | Transmission - Powershift transmission |
| 590SN FOUR-WHEEL DRIVE (4WD) TIER 4B (FINAL) [NGC736228 - ]    | Transmission - Powershift transmission |
| 590SN TWO-WHEEL DRIVE (2WD) TIER 4B (FINAL) [NGC736228 - ]     | Transmission - Powershift transmission |

1. Assemble new teflon ring and relevant inner O-rings, respectively into the piston outer and inner seats.

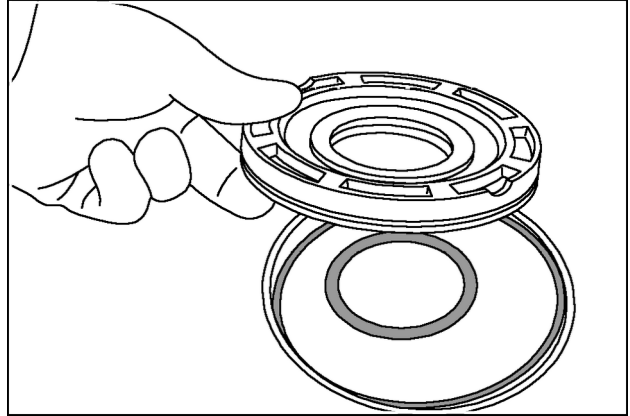

RCPH10TLB266AAL 1

2. Apply a thin film of transmission oil on the sealing rings just inserted.

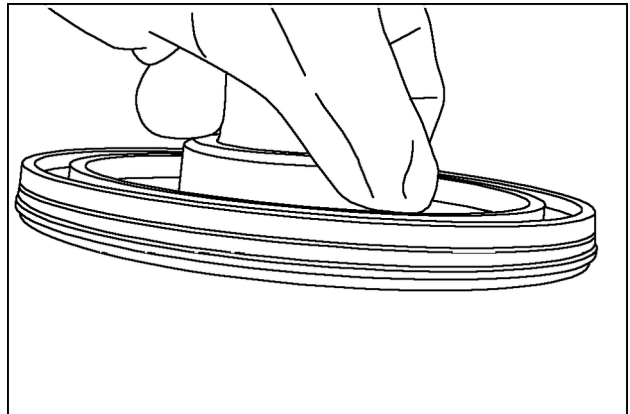

RCPH10TLB198AAL 2

3. Insert the clutch piston using tool 380001926 clutch pack piston installer.

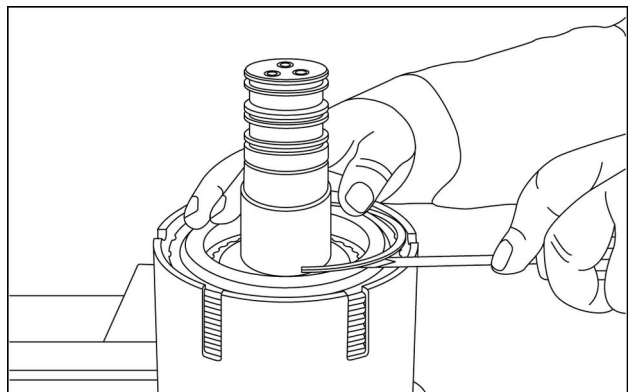

RCPH10TLB931AAL 3

4. Pay attention to the proper assembly

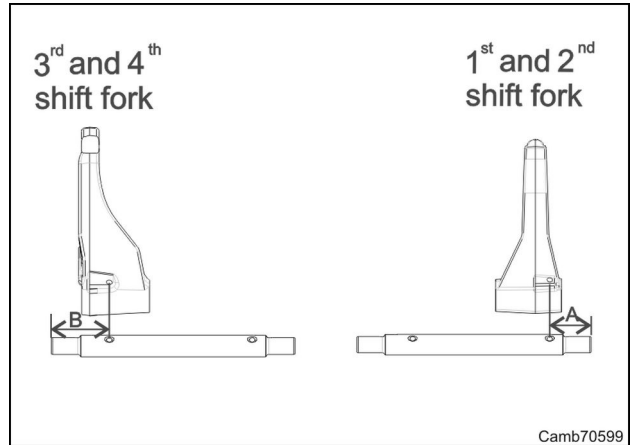

RCPH10TLB075ACL 4

5. Position the roll pin.

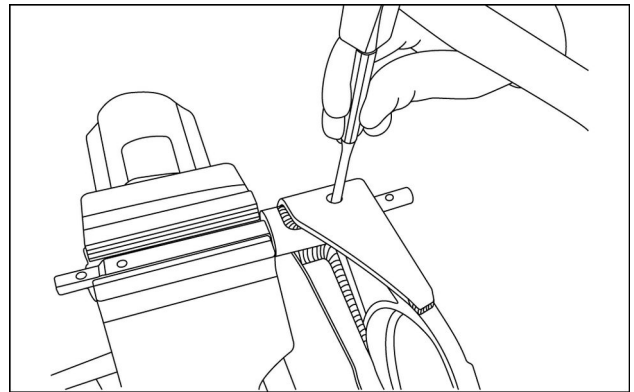

RCPH10TLB198ACL 5

6. 1st and 2nd gear shift fork. Assemble the spring pin to lock the fork to the shift rail.

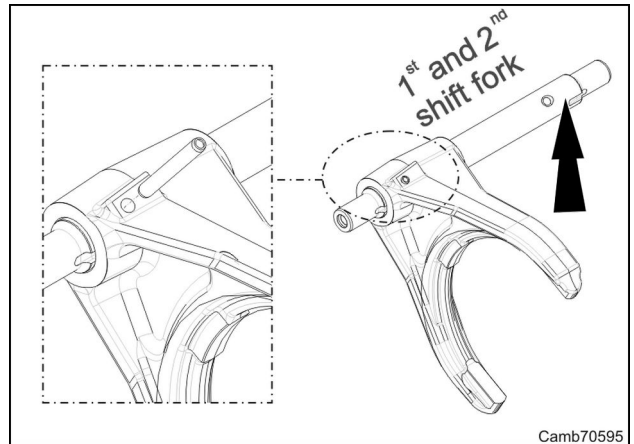

RCPH10TLB071ACL 6

7. 3rd and 4th gear shift fork. Assemble the spring pin to lock the fork to the shift rail.

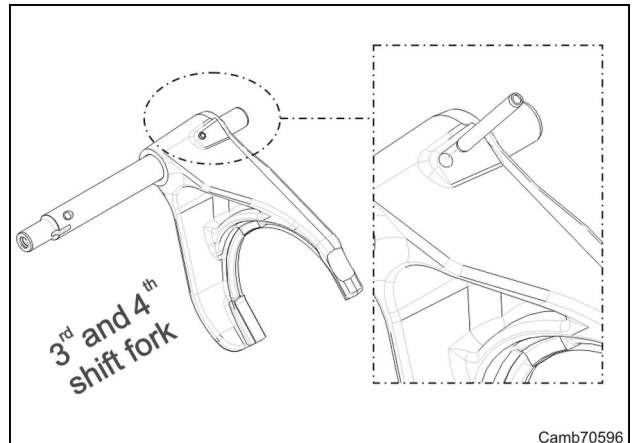

RCPH10TLB072ACL 7

# Index

---

## Transmission - 21

### Powershift transmission internal components - 155

|  |    |
|--|----|
| Clutch - Check S-type (SPS Power Synchro) - Speed gears switches - checking procedure (*) . . . .  | 97 |
| Clutch - Exploded view H-type (*) . . . . .  | 5  |
| Clutch - Measure S-type (SPS Power Synchro) - Speed gears shift rails adjustment - front engagement bushing shim measurement (*) . . . . . | 86 |
| Clutch - Measure S-type (SPS Power Synchro) - Speed gears shift rails adjustment - neutral position measurement (*) . . . . .              | 92 |
| Clutch - Measure S-type (SPS Power Synchro) - Speed gears shift rails adjustment - piston bolt shim measurement (*) . . . . .              | 90 |
| Clutch - Measure S-type (SPS Power Synchro) - Speed gears shift rails adjustment - rear engagement bushing shim measurement (*) . . . . .  | 82 |
| Shaft assemblies - Assemble S-type (SPS Power Synchro) - gear pistons (*) . . . . .  | 22 |
| Shaft assemblies - Assemble S-type (SPS Power Synchro) - rear cover - shafts (*) . . . . .   | 11 |
| Shaft assemblies - Assemble S-type (SPS Power Synchro) - shaft E (4WD) (*) . . . . .   | 72 |
| Shaft assemblies - Assemble S-type (SPS Power Synchro) - shafts A - D (*) . . . . .  | 42 |
| Shaft assemblies - Assemble S-type (SPS Power Synchro) - shafts B- C (*) . . . . .   | 60 |
| Shaft assemblies - Assemble S-type (SPS Power Synchro) - shift rails - forks (*) . . . . .   | 79 |
| Shaft assemblies - Disassemble S-type (SPS Power Synchro) - gear pistons (*) . . . . .   | 17 |
| Shaft assemblies - Disassemble S-type (SPS Power Synchro) - rear cover - shafts (*) . . . . .  | 7  |
| Shaft assemblies - Disassemble S-type (SPS Power Synchro) - shaft E (4WD) (*) . . . . .  | 70 |
| Shaft assemblies - Disassemble S-type (SPS Power Synchro) - shafts A - D (*) . . . . .   | 33 |
| Shaft assemblies - Disassemble S-type (SPS Power Synchro) - shafts B- C (*) . . . . .  | 52 |
| Shaft assemblies - Disassemble S-type (SPS Power Synchro) - shift rails - forks (*) . . . . .  | 77 |
| Shaft assemblies - Exploded view H-type - reverse shaft (*) . . . . .  | 3  |

(\*) See content for specific models

# Contents

---

## Front axle system - 25

### Front bevel gear set and differential - 102

#### FUNCTIONAL DATA

|                   |   |
|-------------------|---|
| Differential      |   |
| Exploded view (*) | 3 |

#### SERVICE

|                                       |    |
|---------------------------------------|----|
| Differential                          |    |
| Remove (*)                            | 6  |
| Disassemble (*)                       | 10 |
| Disassemble axle housing assembly (*) | 15 |
| Inspect (*)                           | 17 |
| Assemble (*)                          | 18 |
| Install                               | 20 |

(\*) See content for specific models

## Planetary drive and hub - Assemble

|  |  |
|--|--|
| 580N FOUR-WHEEL DRIVE (4WD) TIER 4B (FINAL) [NGC730186 - ]     |  |
| 580SN FOUR-WHEEL DRIVE (4WD) TIER 4B (FINAL) [NGC732639 - ]    |  |
| 580SN WT FOUR-WHEEL DRIVE (4WD) TIER 4B (FINAL) [NGC735098 - ] |  |
| 590SN FOUR-WHEEL DRIVE (4WD) TIER 4B (FINAL) [NGC736228 - ]    |  |

### Planetary Carrier

1. Install planetary gear over installation tool DMT100002

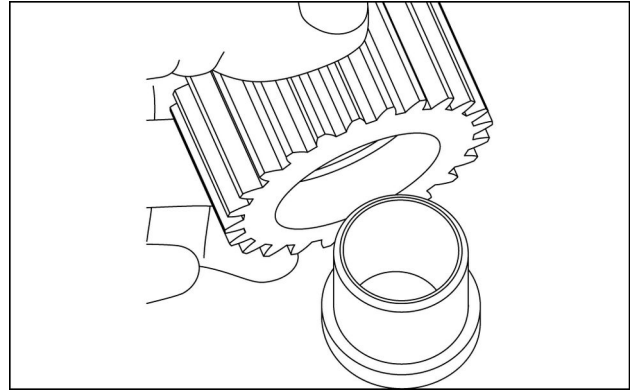

RCPH10TLB370ACL 1

2. Insert rollers between installation assembly tool and gear as shown. Apply petroleum jelly to help retain rollers.

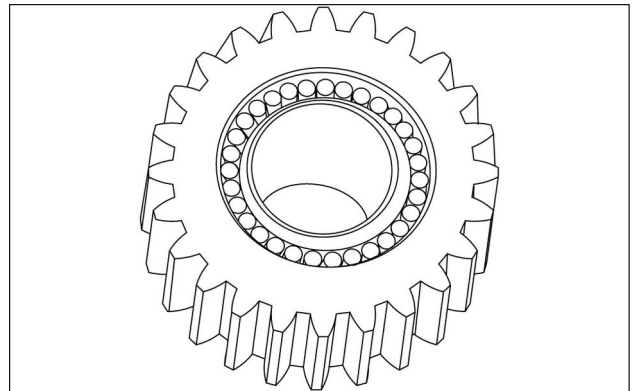

RCPH10TLB371ACL 2

3. Ensure all rollers are installed.

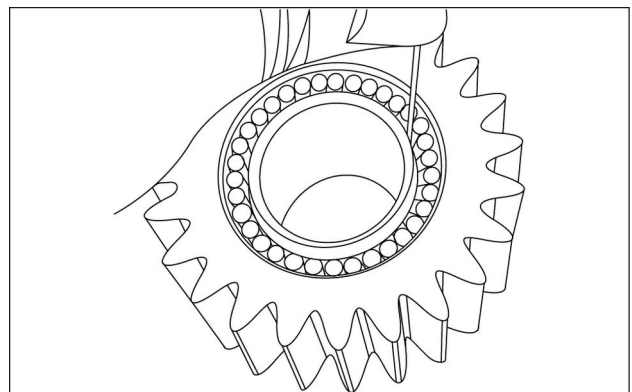

RCPH10TLB372ACL 3

# Index

---

## Front axle system - 25

### Non-powered front axle - 400

|  |    |
|--|----|
| Front axle - Assemble (*) .....              | 12 |
| Front axle - Assemble (*) .....              | 22 |
| Front axle - Disassemble (*) .....           | 8  |
| Front axle - Disassemble (*) .....           | 17 |
| Front axle - General specification (*) ..... | 3  |
| Front axle - Inspect (*) .....               | 11 |
| Front axle - Inspect (*) .....               | 21 |
| Front axle - Install (*) .....               | 27 |
| Front axle - Remove (*) .....                | 5  |
| Front axle - Special tools (*) .....         | 3  |
| Front axle - Special tools (*) .....         | 4  |
| Front axle - Torque (*) .....                | 3  |

(\*) See content for specific models

## Differential - Remove Carrier

|   |  |
|---|--|
| 580N FOUR-WHEEL DRIVE (4WD) TIER 4B (FINAL) [NGC730186 - ]  |  |
| 580N TWO-WHEEL DRIVE (2WD) TIER 4B (FINAL) [NGC730186 - ]   |  |
| 580SN FOUR-WHEEL DRIVE (4WD) TIER 4B (FINAL) [NGC732639 - ] |  |
| 580SN TWO-WHEEL DRIVE (2WD) TIER 4B (FINAL) [NGC732639 - ]  |  |

1. Remove the wheel hubs and brakes.
2. Remove the differential mounting bolts.

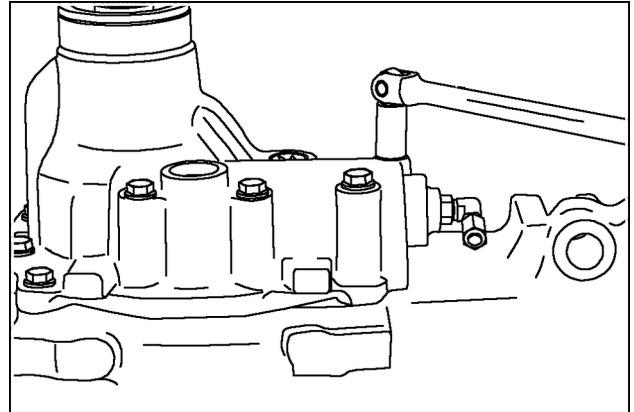

RCPH10TLB373AAL 1

3. Use pry bars in slots.

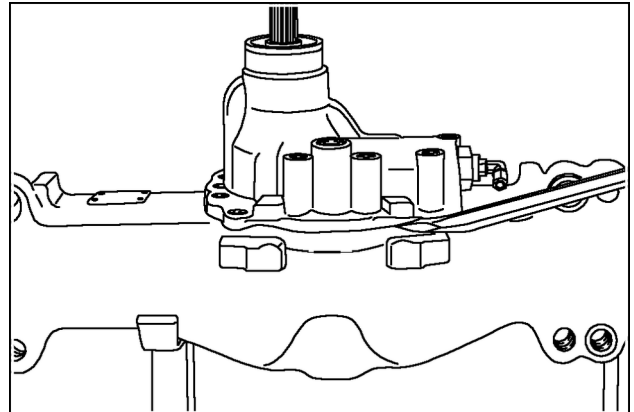

RCPH10TLB374AAL 2

4. Have an assistant hold the differential housing up away from the axle housing, attach a lifting eye to the bottom of the differential housing.

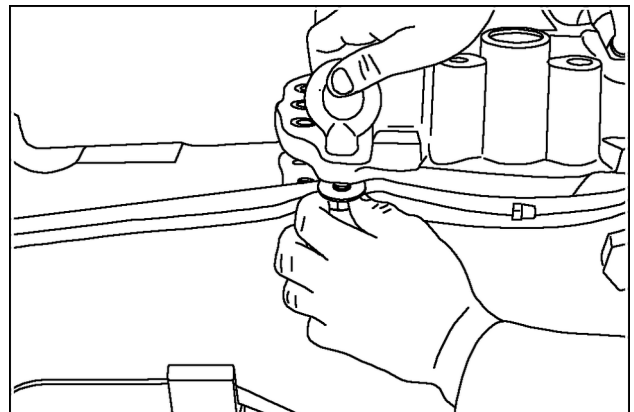

RCPH10TLB370AAL 3

---

## Differential - Check Checking the differential lock

|   |  |
|---|--|
| 580N FOUR-WHEEL DRIVE (4WD) TIER 4B (FINAL) [NGC730186 - ]  |  |
| 580N TWO-WHEEL DRIVE (2WD) TIER 4B (FINAL) [NGC730186 - ]   |  |
| 580SN FOUR-WHEEL DRIVE (4WD) TIER 4B (FINAL) [NGC732639 - ] |  |
| 580SN TWO-WHEEL DRIVE (2WD) TIER 4B (FINAL) [NGC732639 - ]  |  |

1. Connect a hand pump and gauge to the fitting on the differential lock. Have someone turn the wheel hub as slight pressure is applied to the hand pump. If the differential lock is working correctly the wheel hub will become hard to turn and the wheel hub on the opposite side of the axle will turn at the same time.

**NOTE:** Make sure the air is removed from the brake system when the axle is installed on the machine.

4. Lubricate the O-ring and the seal with clean oil. Install the cover on the center section.

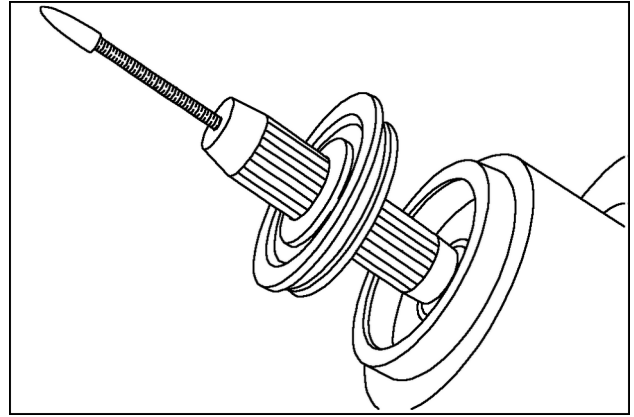

RCPH10TLB543AAL 4

5. Use a soft-face hammer to seat the seal.

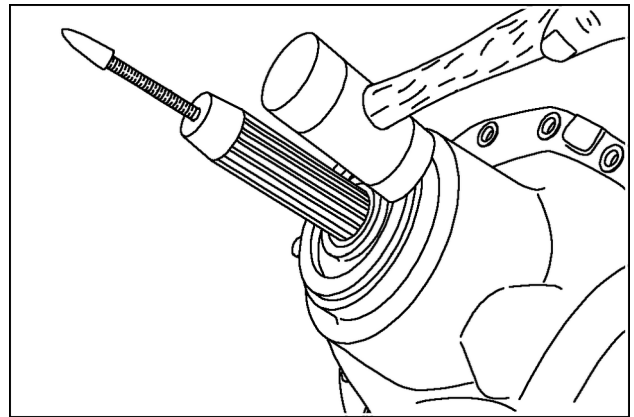

RCPH10TLB537AAL 5

6. Remove the CAS2369 from the pinion gear shaft.

**Next operation:**  
**Differential - Install Carrier (27.106)**

- Stand the hub up, mark the reaction plat that was against the axle housing. Remove the reaction and brake disks.

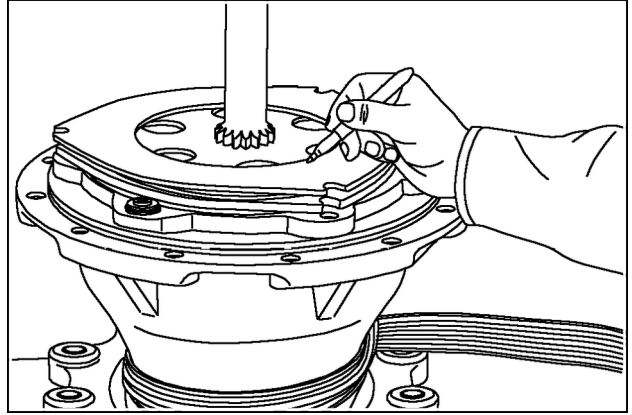

RCPH10TLB399AAL 11

**NOTE:** Keep brake surfaces in same relationship to each other if being reused.

- Remove the half shaft from the planetary gears.

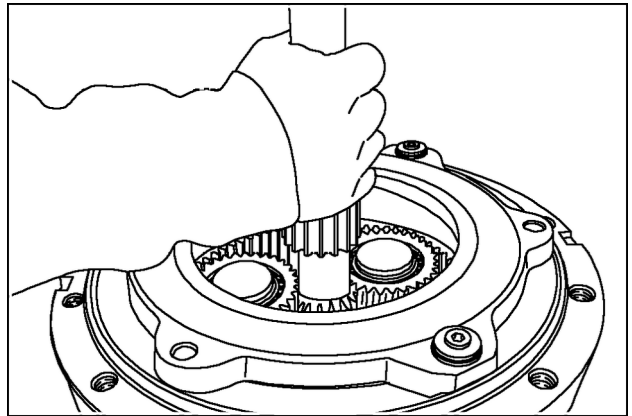

RCPH10TLB311AAL 12

- Left hand shaft is 807 mm (31.7 in) long and the right hand shaft is 701 mm (27.5 in) long.

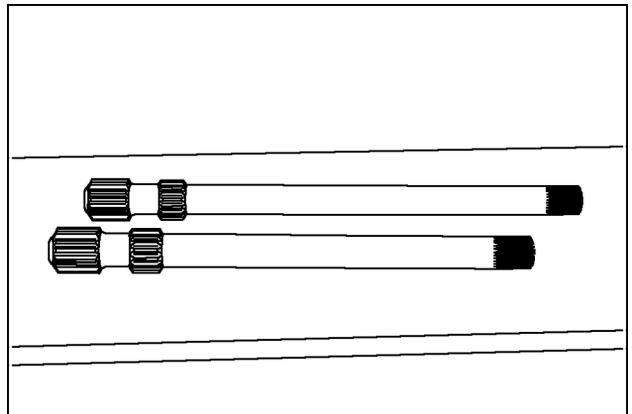

RCPH10TLB375AAL 13

- Loosen and remove the shouldered bolts, and spring washers from the brake self adjusters.

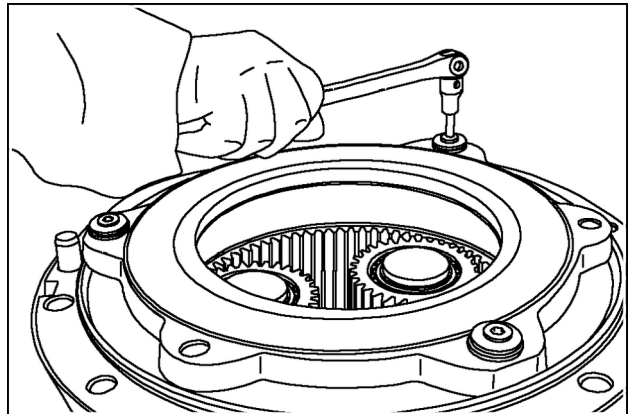

RCPH10TLB312AAL 14

4. Lubricate the piston seals with clean transmission fluid. Install the piston into the brake housing.

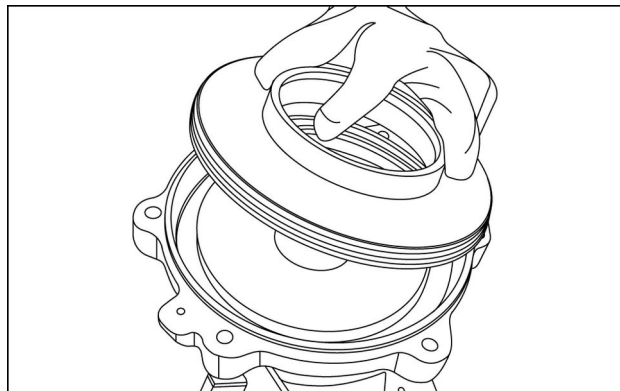

RCPH10TLB602AAL 4

5. Use CAS2379 and compress the bellville washers. Install the retaining ring.

**NOTICE:** Make sure the retainer is properly seated before removing spring compressor.

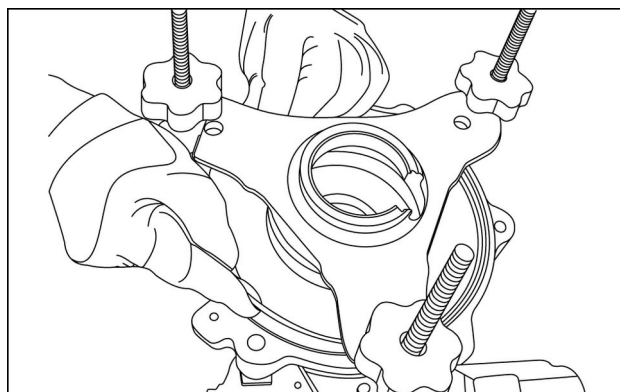

RCPH10TLB601AAL 5

6. Install new O-rings and a new backup ring in the retaining plate.

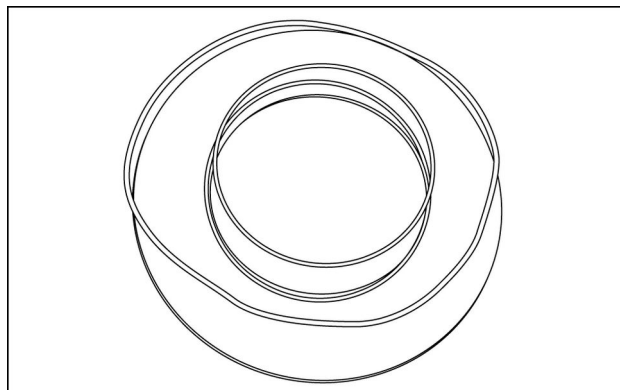

RCPH10TLB600AAL 6

7. Lubricate the O-rings on the retaining plate. Install the plate into the brake housing.

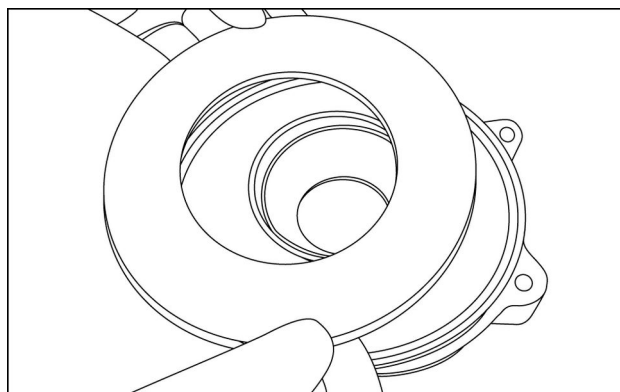

RCPH10TLB599AAL 7

8. Disconnect the supply hose and the return hose from the master cylinder. Place caps on the fittings. Plug the open hoses.

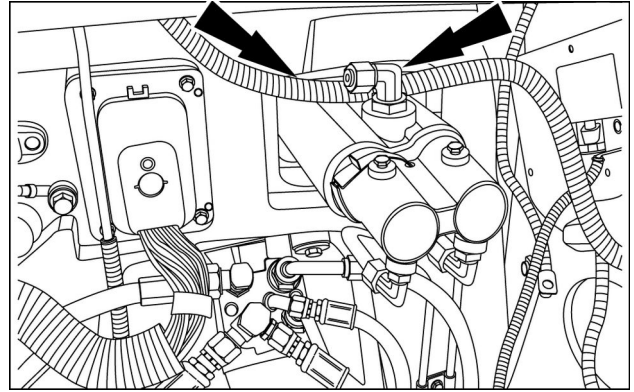

RCPH10TLB593AAL 4

**NOTE:** The supply hose and the fittings are located behind the return elbow.

9. Disconnect the tubes from the master cylinder. Put caps on the fittings. Plug the open tubes.

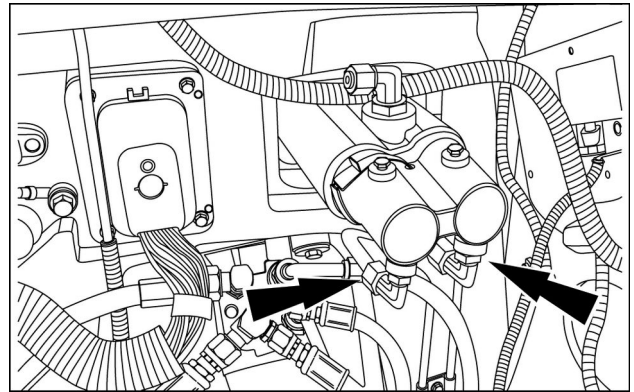

RCPH10TLB593AAL 5

10. Remove the cotter pins and the clevis pins. Loosen and remove the nuts that fasten the master cylinder to the frame.

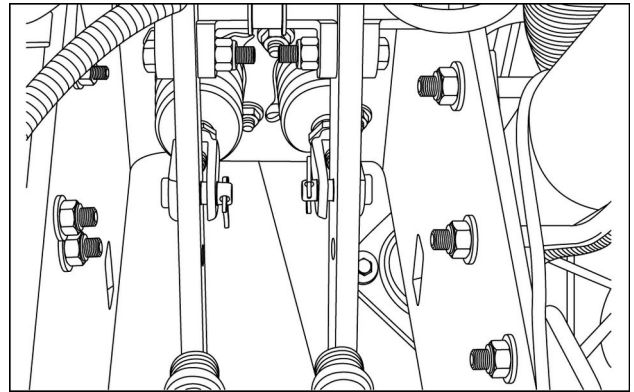

RCPH10TLB592AAL 6

11. Remove the master cylinder from the frame.

**Next operation:**  
**Brake master cylinder - Install (33.202)**

|                                     |                                 |
|-------------------------------------|---------------------------------|
| 20P. Bucket spool                   | 44. Oil cooler                  |
| 20S. Extendahoe spool               | 45. Hydraulic filter            |
| 20U. Bi-directional auxiliary spool | 46. Dual auxiliary return valve |
| 35. 5 Bar back pressure valve       | 48. PowerLift control valve     |

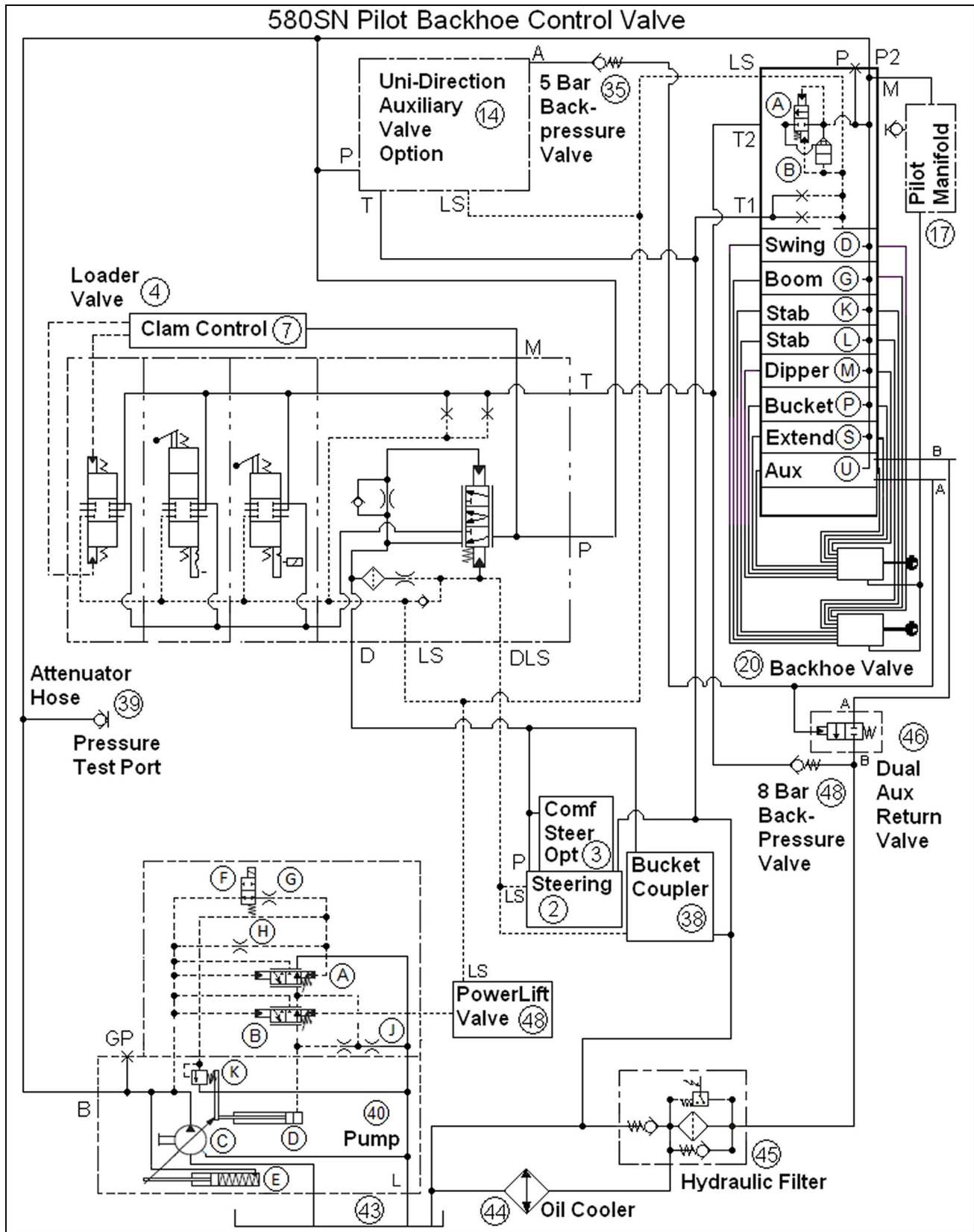

RAPH12TLB0120GA 11

**580SN pilot backhoe control valve**



### **Test 5H**

1. Lower the right stabilizer. Hold the right stabilizer in position.
2. Monitor the flowmeter. Record the flow results on the Flowmeter Check Sheet.

### **Test 5I**

1. Roll the backhoe bucket to the dump position. Hold the backhoe bucket in the dump position.
2. Monitor the flowmeter. Record the flow results on the Flowmeter Check Sheet.

### **Test 5J**

1. Roll the backhoe bucket to the dig position. Hold the backhoe bucket in the dig position.
2. Monitor the flowmeter. Record the flow results on the Flowmeter Check Sheet.

### **Test 5K**

1. Position the dipper in the full extended position. Hold the dipper in the full extended position.
2. Monitor the flowmeter. Record the flow results on the Flowmeter Check Sheet.

### **Test 5L**

1. Position the dipper in the full retract position. Hold the dipper in the full retract position.
2. Monitor the flowmeter. Record the flow results on the Flowmeter Check Sheet.

### **Test 5M**

1. Position the boom in the lower position. Hold the boom in the lower position.
2. Monitor the flowmeter. Record the flow results on the Flowmeter Check Sheet.

### **Test 5N**

1. Position the boom in the raised position. Hold the boom in the raised position.
2. Monitor the flowmeter. Record the flow results on the Flowmeter Check Sheet.

### **Test 5O**

1. If equipped with the bi-directional auxiliary hydraulics, set the selector switch to Bi-Aux. Unhook the quick disconnect couplers or cap the lines. Hold the button in the out position.
2. Monitor the flowmeter. Record the flow results on the Flowmeter Check Sheet.

## Hydraulic systems - Adjust Torque Control Adjustment, Pilot controls

|  |  |
|--|--|
| 580SN FOUR-WHEEL DRIVE (4WD) TIER 4B (FINAL) [NGC732639 - ]    |  |
| 580SN TWO-WHEEL DRIVE (2WD) TIER 4B (FINAL) [NGC732639 - ]     |  |
| 580SN WT FOUR-WHEEL DRIVE (4WD) TIER 4B (FINAL) [NGC735098 - ] |  |
| 590SN FOUR-WHEEL DRIVE (4WD) TIER 4B (FINAL) [NGC736228 - ]    |  |
| 590SN TWO-WHEEL DRIVE (2WD) TIER 4B (FINAL) [NGC736228 - ]     |  |

For this test the machine will see pressure of at least **221 bar (3200 psi)**. A **75 US gpm** flowmeter (CAS10280) will be used. If the flowmeter is equipped with pipe thread connections, these fittings will have to be removed and replaced with ORFS connections (p/n 87303844). A hose with a minimum **275 bar (4000 psi)** working pressure must be used. It is recommended that the hoses be made **2438.4 - 3657.6 mm (96.0 - 144.0 in)** long with #16 female ORFS (1 7/16-12) ends.

1. Remove the tee from the pressure outlet at the rear of the pump and install a plug ( 9847694) in the open end of the tee and tighten.
2. Attach one end of a test hose to the adapter fitting at the pressure outlet of the pump. Connect the other end of the hose to the inlet port of the test flowmeter.
3. Remove the #16 ORB internal hex plug from the rear face of the backhoe valve.
4. Install a long #16 ORB to #16 ORFS adapter fitting ( 87326799) in the open port of the backhoe valve.
5. Connect the end of the second test hose at the adapter fitting on the backhoe valve. The opposite end of the hose must be connected to the outlet of the service flowmeter.
6. Remove the plug from the pressure gauge port at the top rear of the pump.
7. Install a tee 84151565 in the gauge port at the top of the pump.
8. Remove the hose that connects the load sense compensator to the power lift valve. Cap the open connection at the power lift valve.
9. Connect a hose from the tee at the gauge port of the pump to the open port at the LS compensator. The hose needs to have #6 ORFS female ends and be rated to **275 bar (4000 psi)**.
10. Connect a diagnostic fitting 190119A1 at the available port on the gauge port tee.
11. Warm the machine to **50 °C (120 °F)**. To warm the machine, start the engine and set the throttle to **2000 RPM**. Adjust the load valve at the service flowmeter to **172 - 207 bar (2500 - 3000 psi)**. Allow the machine to run in this condition until the temperature is reached.
12. Stop the engine.
13. Connect a gauge capable of **35 bar (500 psi)** to the diagnostic fitting installed at the tee in the gauge port of the pump.

## Pump control valves - Cleaning Pilot machines only

|  |  |
|--|--|
| 580N FOUR-WHEEL DRIVE (4WD) TIER 4B (FINAL) [NGC730186 - ] |  |
| 580N TWO-WHEEL DRIVE (2WD) TIER 4B (FINAL) [NGC730186 - ]  |  |

1. Remove the valve from the machine, see **Remote control valve - Remove (35.204)**
2. Clean the valve.
3. Loosen the plug.

**NOTE:** During assembly torque to **90 - 110 N·m (66 - 81 lb ft)**.

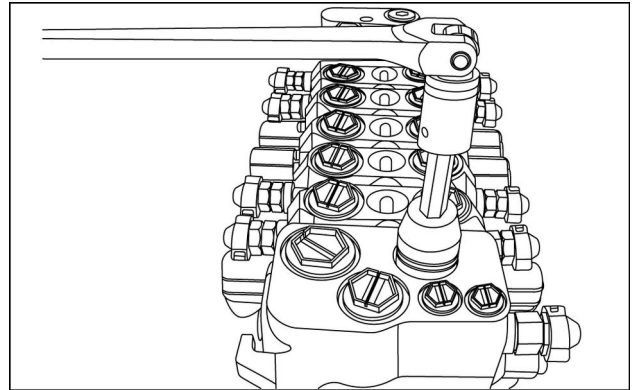

RCPH10TLB392ABL 1

4. Remove the plug.

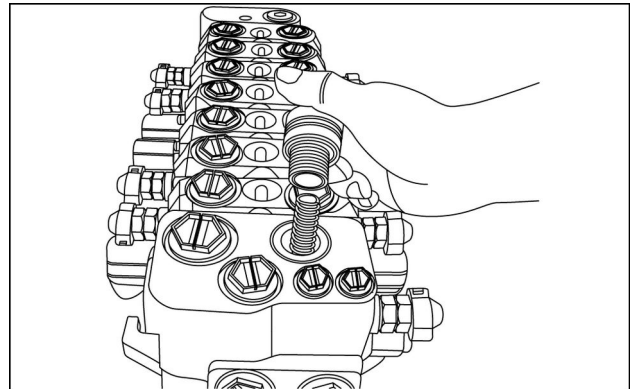

RCPH10TLB393ABL 2

5. Remove the springs.

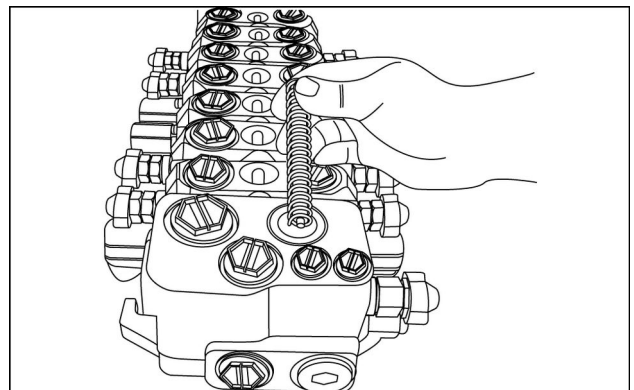

RCPH10TLB394ABL 3

9. Install the drive and the driven gear.

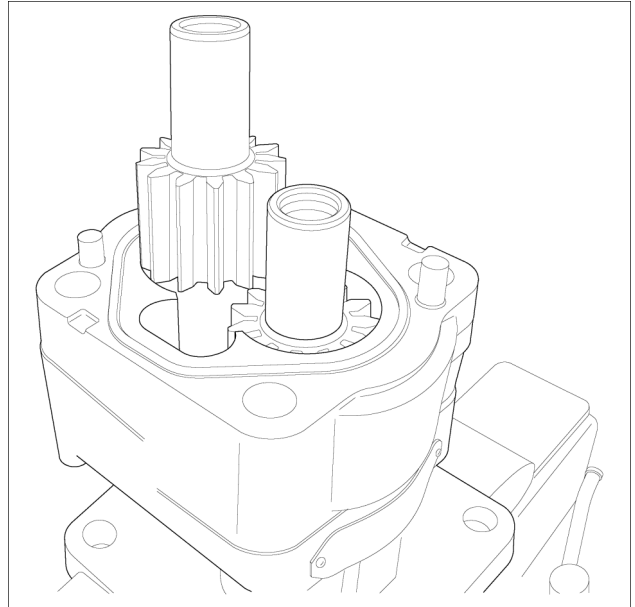

RCPH11TLB009BAL 8

10. Install the thrust plate so that the seal is up. The seal must be toward the outlet side of the hydraulic pump.

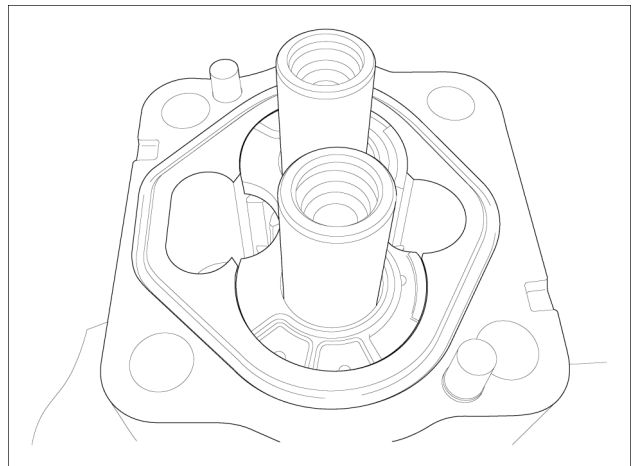

RCPH11TLB010BAL 9

11. Install the quad ring.

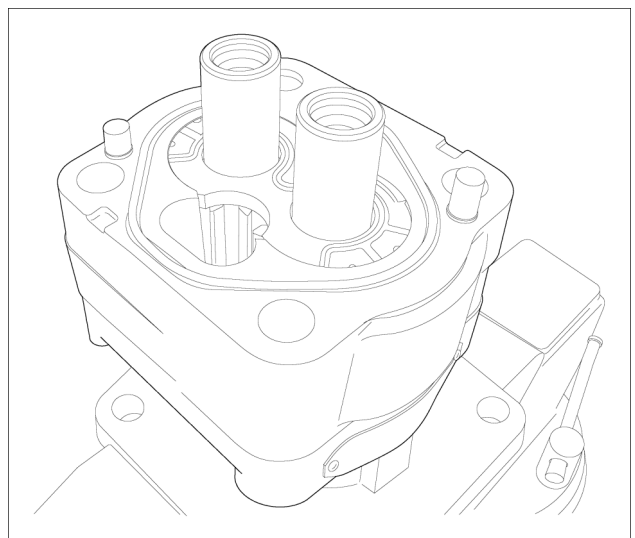

RCPH11TLB011BAL 10

7. There is one large and four small O-rings that seal the rear cover of the pump. Remove these and set aside.
8. Remove the rear bearing and spacer underneath from the pump shaft.
9. With a helper, remove the pump from the vise.
10. While holding the rotating group into the pump, tilt the pump and pour the oil from the pump case into a bucket or drain pan.
11. Set the pump on a workbench with the shaft horizontal and remove the rotating group from the pump. It is best to reach in past the cylinder and separate the piston shoes from the swash plate.
12. Remove the two screws holding the torque control variable relief onto the top of the pump. Remove the variable relief.
13. Remove the single screw holding the relief valve cam onto the swash plate. Note the orientation of the cam, then pull it free of the swash plate. The cam is pressed onto a pin, so a pair of pliers may be used to pull the cam loose.
14. Remove the swash plate and shaft from the pump.
15. Remove the swash plate trunnion bearings (1) from the pump housing.

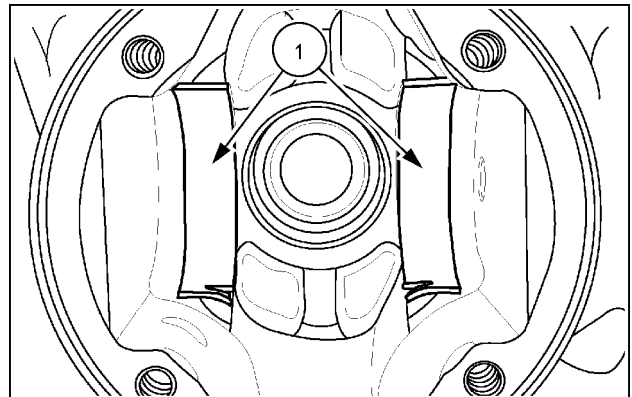

RCPH10CCH698BAO 5

16. Remove the seal from the pump housing.
17. Remove the shaft from the swash plate and rotation group.
18. Using a press, remove the tapered roller bearing cone.

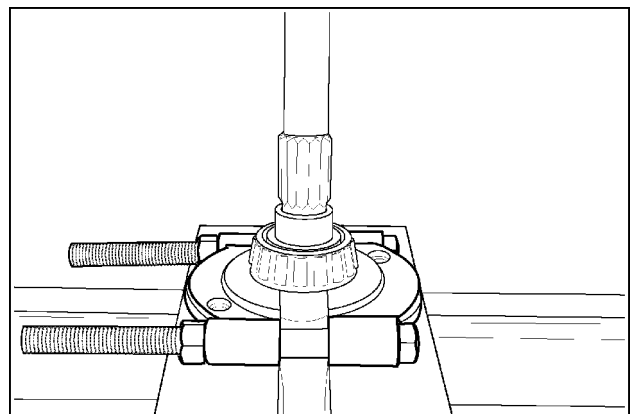

RCPH10CCH701BAO 6

19. Mark the pistons and retaining plate with their position in the cylinder. Remove the pistons and retaining plate.

## Remote control valve - Remove - Remote control valves

1. Park the machine on a level surface and lower the bucket to the floor. Stop the engine and apply the parking brake.

**NOTICE:** Turn on the ignition switch and the pilot control switch. Move the backhoe control lever back and forth several times to release any hydraulic pressure in the pilot control circuit.

2. Place the pilot control switch and the ignition switch in the OFF position.
3. Remove the wrist rest, pull the rubber boot up and remove the two mounting screws and the retaining plate.

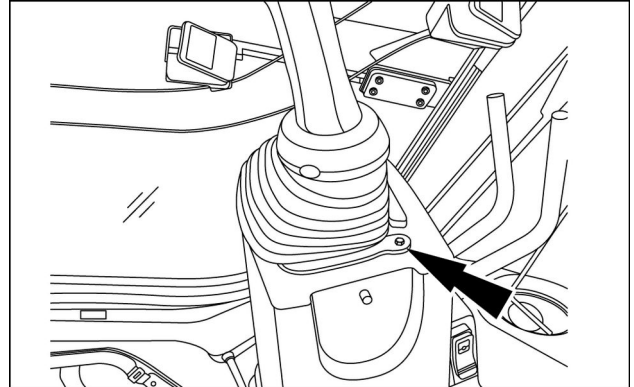

RCPH10TLB334ABL 1

4. On the right tower (facing rear of machine) remove the tilt levers.

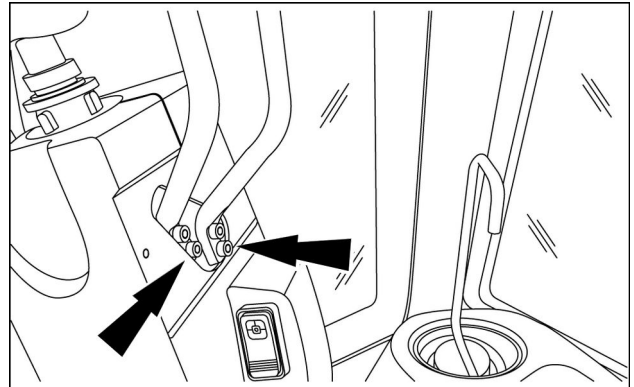

RCPH10TLB335ABL 2

5. Remove the tilt adjusting knob from rear of tower.

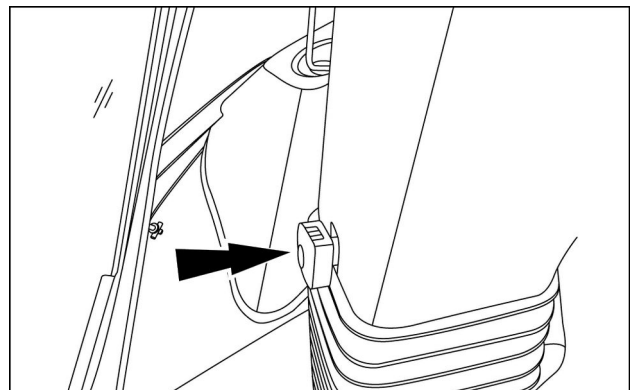

RCPH10TLB336ABL 3

6. Remove the rear floor mat (if equipped) and floor boards.

## Oil reservoir - Install

### Prior operation:

#### Oil reservoir - Remove (35.300)

1. Raise the oil reservoir into position using a floor jack and install the bolts at the front of the reservoir **(1)**. Torque the bolts to **271 - 407 N·m (200 - 300 lb ft)**.

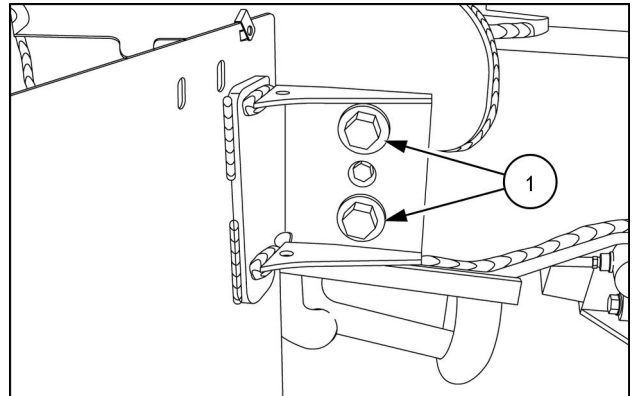

RAIL14TLB1329AA 1

2. Install the bolts **(1)** at the rear of the reservoir and torque the bolts to **271 - 407 N·m (200 - 300 lb ft)**.

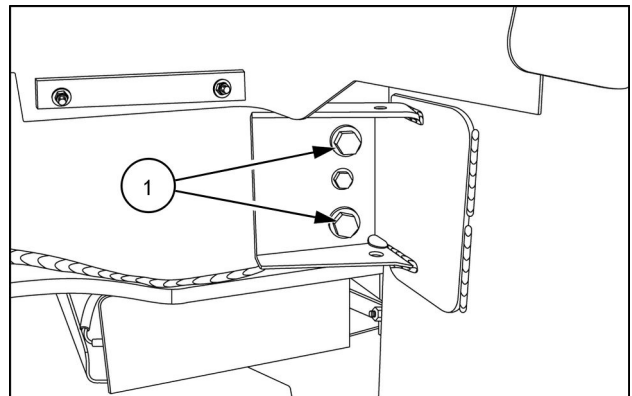

RAIL14TLB1328AA 2

3. Install the hose **(2)** and tighten the clamp **(1)**.

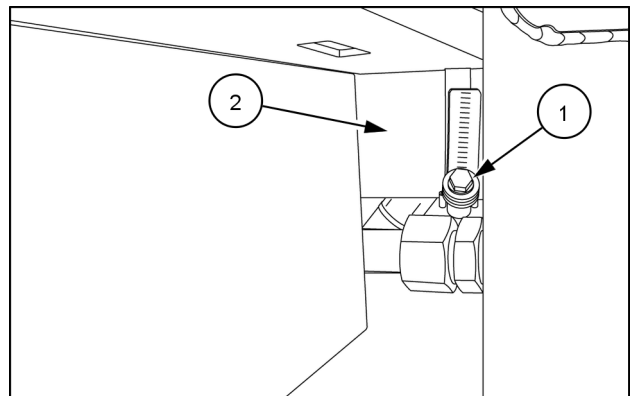

RAIL14TLB1330AA 3

4. Connect and tighten the tube **(1)**.

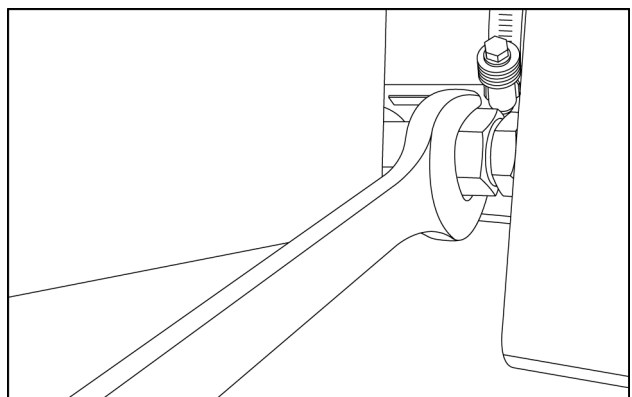

RAIL14TLB1331AA 4



9. Loosen the anti void plug.

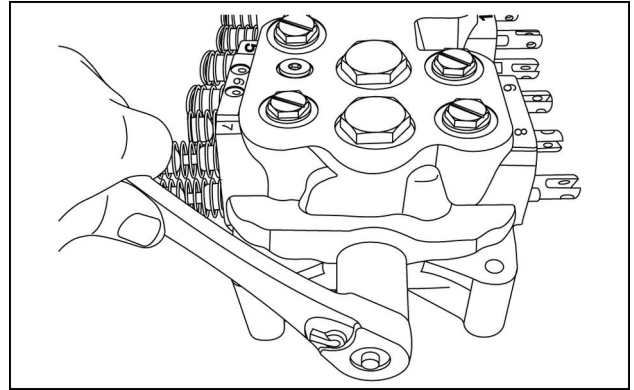

RCPH10TLB159ABL 8

10. Replace the O-rings and backup ring on the anti void valve and plug.

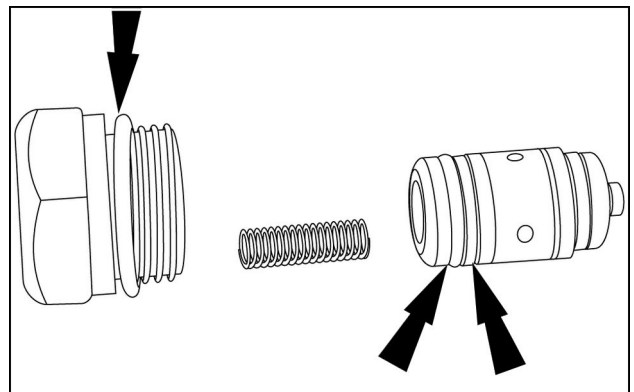

RCPH10TLB157ABL 9

11. Install and hand tighten the plug into the valve body making sure not to bind the valve.

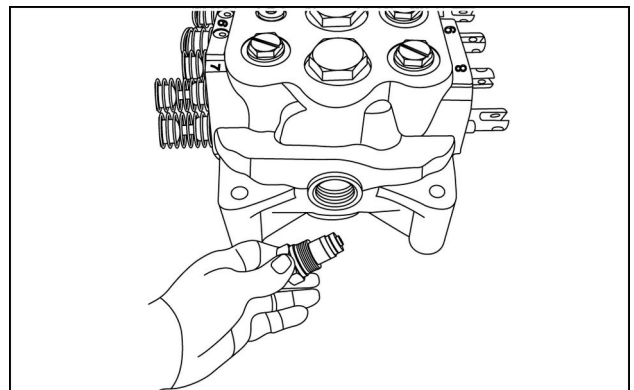

RCPH10TLB160ABL 10

12. Torque the anti void to **65 N·m +/- 6.7 (48 lb ft +/- 5)**

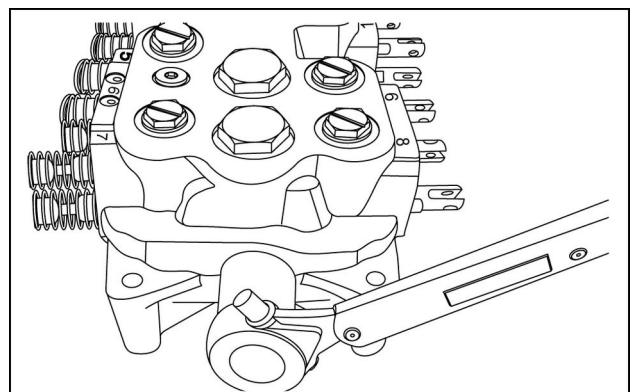

RCPH10TLB158ABL 11

---

## Quick coupling - Disassemble - Quick coupler cylinder

**NOTE:** Refer to *Quick coupling - Exploded view - Extendahoe (35.525)*

1. Remove the bucket from the backhoe.
2. Remove the retaining rings **(1)** from the sleeves **(11)** and **(23)**.
3. Extend the piston rods out.
4. Remove the groove pins **(2)** from the step pins **(3)**.
5. Remove the step pins **(3)**.

**NOTE:** Step pins can be difficult to remove, due to the fit of the step pin seal **(14)**.

6. Remove the snap ring **(2)** from the gland **(5)**. Then push the gland **(5)** slightly into the cylinder.
7. Remove the spacer **(3)**.
8. Remove the snap ring **(4)** from the tube **(1)**.
9. Install the plastic service ring into the snap ring groove in the tube **(1)**.

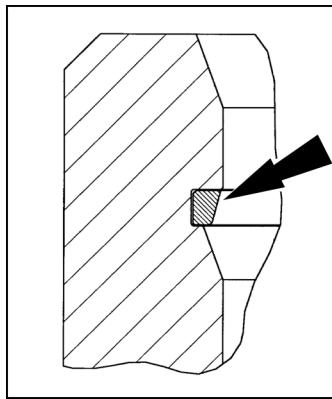

RCPH10TLB019AAL 1

10. Pull the rod assembly **(6)** out of the tube **(1)**.
11. Remove the plastic service ring from the tube **(1)**.
12. Remove the gland **(5)** from the rod **(6)**.
13. Fasten the rod **(6)** in a vise with soft jaws.
14. Remove the seal **(7)**, ring **(8)**, ring **(9)**, and O-ring **(10)** from the piston.
15. Remove the wiper seal **(11)**, bushing **(12)**, seal **(13)**, O-ring **(14)**, and backup ring **(15)** from the gland **(5)**.

**NOTE:** Repeat steps 6 through 15 for the other side.

**Next operation:**

**Quick coupling - Inspect (35.525)**

# Contents

---

## Hydraulic systems - 35

### Front loader bucket hydraulic system - 723

#### FUNCTIONAL DATA

|  |   |
|--|---|
| Loader bucket control cylinder             |   |
| Exploded view Typical cylinder .....       | 3 |
| Exploded view Typical cylinder .....       | 4 |
| Exploded view Quick coupler cylinder ..... | 6 |

#### SERVICE

|  |    |
|--|----|
| Loader bucket control cylinder           |    |
| Remove Loader lift cylinder .....        | 9  |
| Install Loader lift cylinder .....       | 12 |
| Remove Loader cylinder and link .....    | 15 |
| Install Loader cylinder and link .....   | 19 |
| Disassemble Quick coupler cylinder ..... | 22 |
| Inspect Quick coupler cylinder .....     | 23 |
| Assemble Quick coupler cylinder .....    | 24 |
| Assemble .....                           | 25 |
| Inspect .....                            | 29 |
| Disassemble .....                        | 31 |

## Control valve lever - Adjust Adjustment of the backhoe control levers

1. All control levers (1) must be in alignment and centered in the slots in the control tower (2). See the illustration below.
2. All control levers (1) must be within  $71 - 73^\circ$  from the floor plate as seen from the right side of the backhoe.

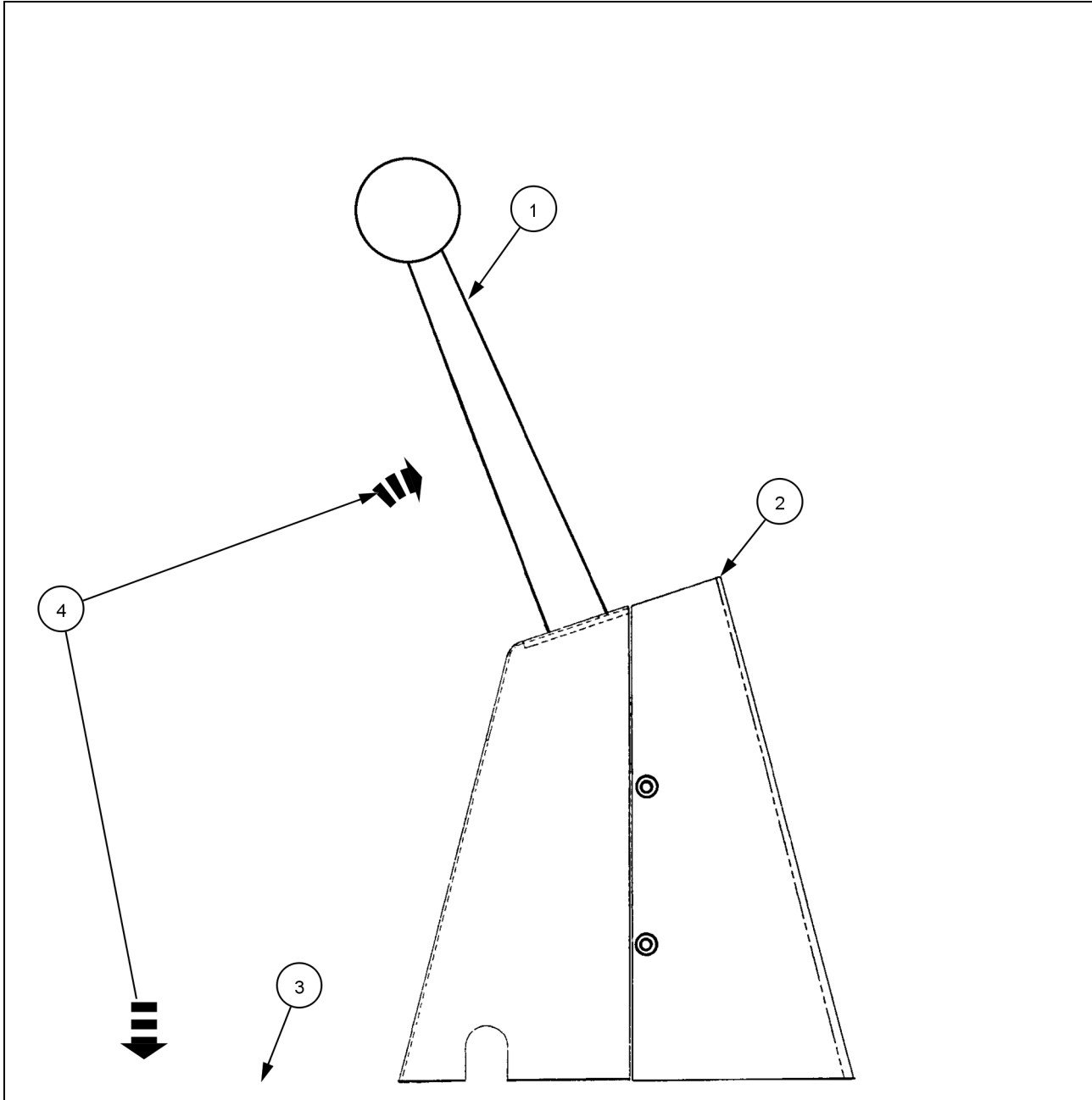

RCPH10TLB094GAL 1

(Right Side Shown)

- |                   |                    |
|-------------------|--------------------|
| 1. Control levers | 3. Floor plate     |
| 2. Control tower  | 4. $71 - 73^\circ$ |

# Index

---

## Hydraulic systems - 35

### Dipper hydraulic system - 737

|   |    |
|---|----|
| Dipper cylinder - Assemble .....          | 12 |
| Dipper cylinder - Disassemble .....       | 10 |
| Dipper cylinder - Exploded view .....     | 5  |
| Dipper cylinder - Install .....           | 14 |
| Dipper cylinder - Overhaul .....          | 11 |
| Dipper cylinder - Remove .....            | 7  |
| Dipper cylinder - Special tools .....     | 3  |
| Dipper cylinder - Torque (*) .....        | 3  |
| Dipper cylinder - Torque (*) .....        | 3  |
| Dipper relief valve - Pressure test ..... | 16 |
| Dipper relief valve - Replace .....       | 17 |

(\*) See content for specific models

## Telescopic arm cylinder - Exploded view

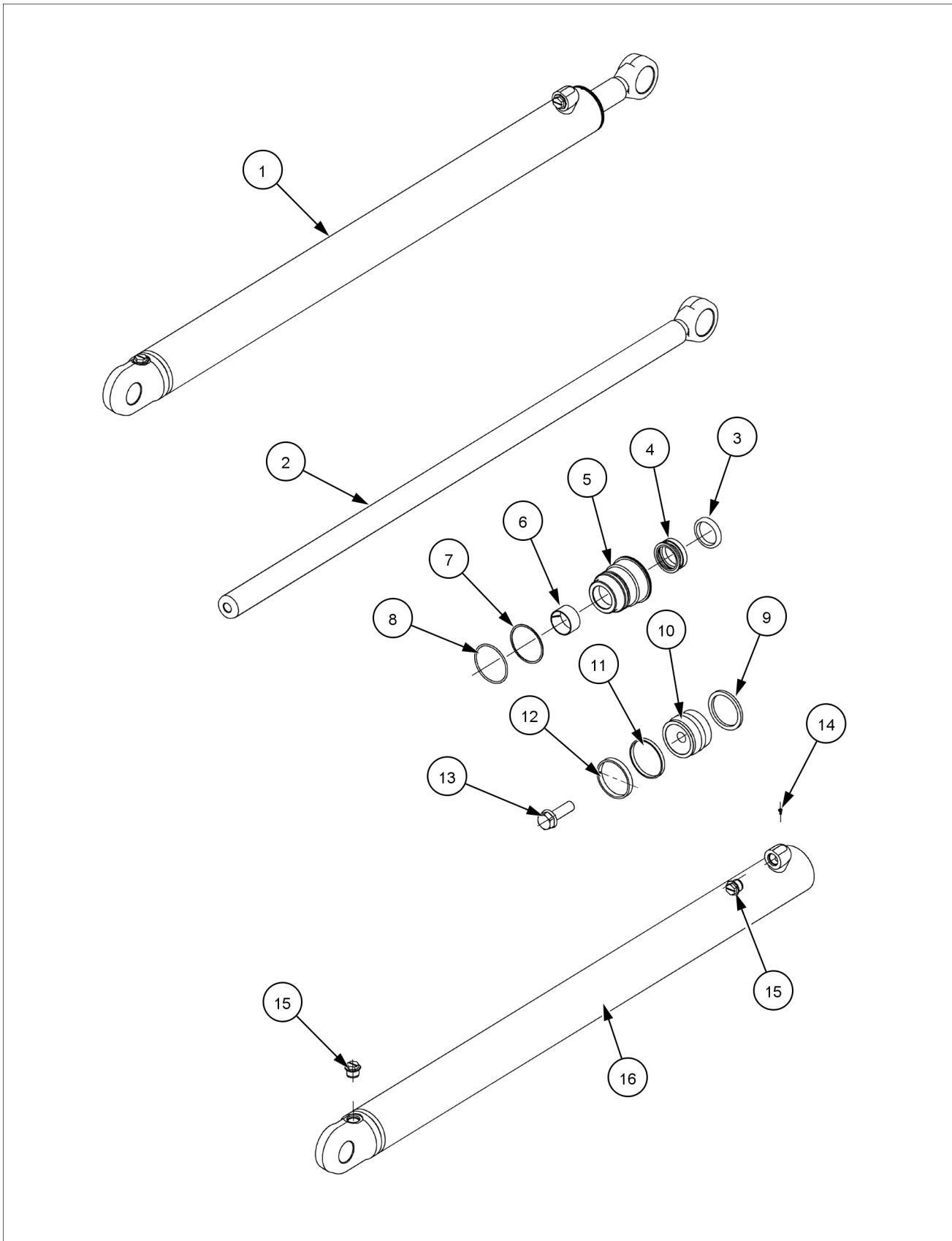

RCPH11TLB020HAN 1

|   |                                     |    |          |
|---|-------------------------------------|----|----------|
| 1 | Extendable dipper cylinder assembly | 9  | Loader   |
| 2 | Piston rod                          | 10 | Cylinder |

Steering - Steering control

|   |                                   |    |                                    |
|---|-----------------------------------|----|------------------------------------|
| 6 | Cover                             | 14 | Screw                              |
| 7 | Turn signal indicator connector   | 15 | Transmission shift lever connector |
| 8 | Upper steering wheel column cover |    |                                    |

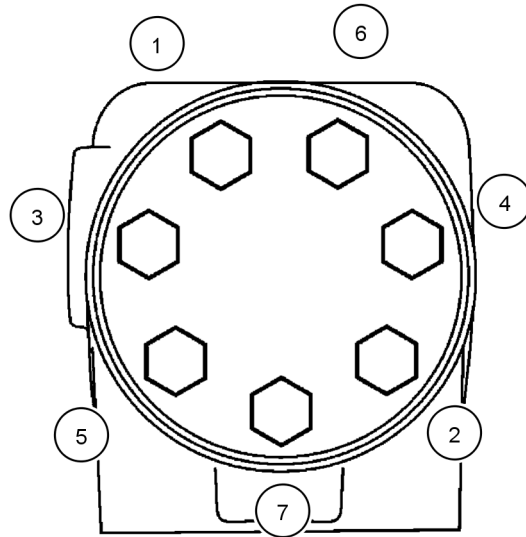

RCPH10TLB003BAM 25

28. Assembled unit should rotate smoothly.

CLICK HERE TO **DOWNLOAD** THE COMPLETE MANUAL

- Thank you very much for reading the preview of the manual.
- You can download the complete manual from: [www.heydownloads.com](http://www.heydownloads.com) by clicking the link below



- Please note: If there is no response to CLICKING the link, please download this PDF first and then click on it.

CLICK HERE TO **DOWNLOAD** THE COMPLETE MANUAL

# Index

---

## Wheels - 44

### Front wheels - 511

|  |   |
|--|---|
| Front wheels - Install .....   | 6 |
| Front wheels - Remove .....  | 5 |
| Front wheels - Service instruction - Tire pressure and condition ..... | 4 |
| Front wheels - Tire pressure .....                                     | 3 |
| Front wheels - Torque .....  | 3 |

## Air-conditioning compressor - Disassemble Clutch disassembly

1. See **Air-conditioning compressor - Disassemble (50.200)** in this service manual for compressor removal. Clean the external surfaces of the compressor before doing any work on the compressor.

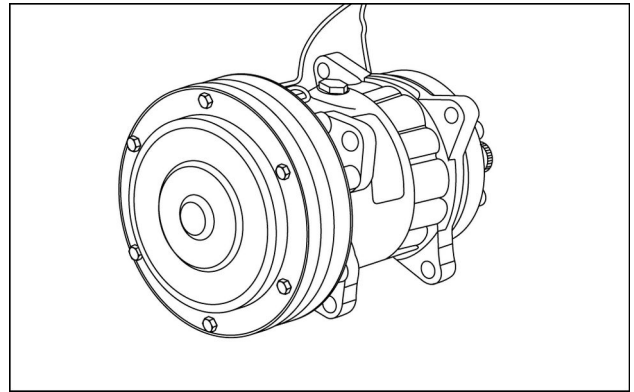

RCPH10TLB631AAL 1

2. Remove the mounting bolts for the clutch dust cover.

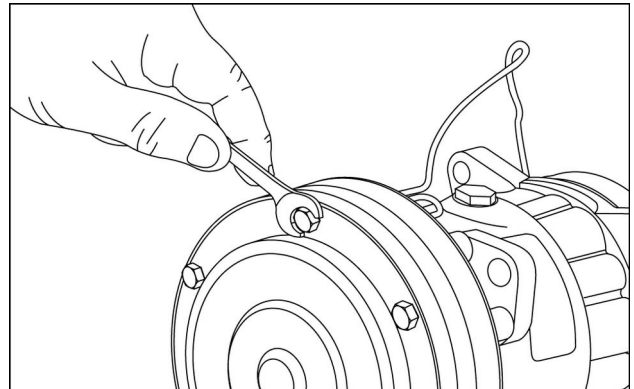

RCPH10TLB632AAL 2

3. Remove the clutch dust cover.

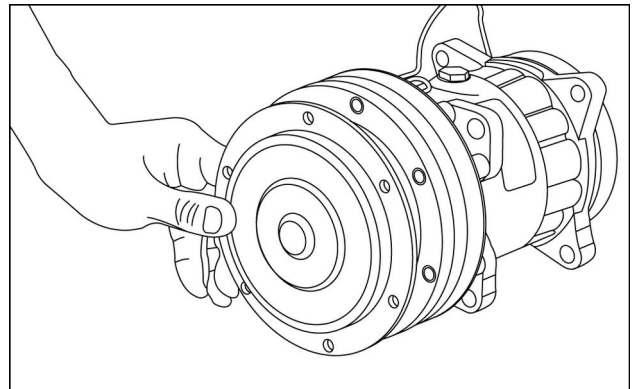

RCPH10TLB633AAL 3

4. Remove the retaining nut for the front plate. Use the special spanner wrench from the service tool set to keep the plate and shaft from turning.

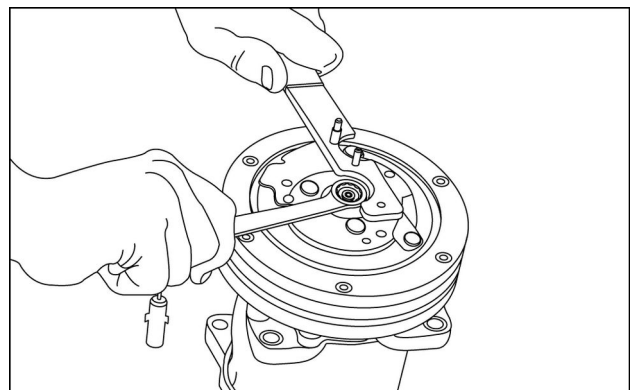

RCPH10TLB634AAL 4

## Wiring harnesses - Electrical schematic sheet 02 SH02 - POWER DISTRIBUTION/CHARGING SYSTEM

|  |                              |
|--|------------------------------|
| 580N FOUR-WHEEL DRIVE (4WD) TIER 4B (FINAL) [NGC730186 - ]     | Transmission - Power Shuttle |
| 580N TWO-WHEEL DRIVE (2WD) TIER 4B (FINAL) [NGC730186 - ]      | Transmission - Power Shuttle |
| 580SN FOUR-WHEEL DRIVE (4WD) TIER 4B (FINAL) [NGC732639 - ]    | Transmission - Power Shuttle |
| 580SN TWO-WHEEL DRIVE (2WD) TIER 4B (FINAL) [NGC732639 - ]     | Transmission - Power Shuttle |
| 580SN WT FOUR-WHEEL DRIVE (4WD) TIER 4B (FINAL) [NGC735098 - ] | Transmission - Power Shuttle |
| 590SN FOUR-WHEEL DRIVE (4WD) TIER 4B (FINAL) [NGC736228 - ]    | Transmission - Power Shuttle |
| 590SN TWO-WHEEL DRIVE (2WD) TIER 4B (FINAL) [NGC736228 - ]     | Transmission - Power Shuttle |

| Type           | Component      | Connector / Link | Description                     |
|----------------|----------------|------------------|---------------------------------|
| Fuse           | <b>F-033</b>   |                  | ALWAYS HOT FOR CUSTOMER OPTION  |
| Voltage source | <b>G-001</b>   |                  | BATTERY                         |
| Voltage source | <b>G-002</b>   | P7               | ALTERNATOR                      |
| Voltage source | <b>G-003</b>   |                  | BATTERY                         |
| Ground         | <b>GND-003</b> | GND-003          |                                 |
| Relay          | <b>K-001</b>   | <b>X-016</b>     | POWER RELAY 1                   |
| Relay          | <b>K-002</b>   | <b>X-017</b>     | POWER RELAY 2                   |
| Relay          | <b>K-003</b>   |                  | POWER RELAY 3                   |
| Relay          | <b>K-004</b>   |                  | POWER RELAY 4                   |
| Relay          | <b>K-031</b>   |                  | SHUTDOWN RELAY 1                |
| Switch         | <b>SW-018</b>  |                  | BATT DISCONNECT SWITCH - OPTION |
| Connector      | X-005          | <b>X-005</b>     | PWR OPT                         |
| Connector      | X-013          | <b>X-013</b>     |                                 |
| Connector      | X-016          | <b>X-016</b>     | PWR RLY 1                       |
| Connector      | X-017          | <b>X-017</b>     | PWR RLY 2                       |
| Connector      | X-019          | <b>X-019</b>     |                                 |
| Connector      | X-040          | <b>X-040</b>     | CONNECT TO X-150 (SIDE)         |
| Connector      | X-122          | <b>X-122</b>     | PWR TO SIDE (X-123)             |
| Connector      | X-123          | <b>X-123</b>     | TO CHASSIS (X-122)              |
| Connector      | X-147          | <b>X-147</b>     |                                 |
| Connector      | X-150          | <b>X-150</b>     | CONNECT TO X-040 (FRONT)        |
| Connector      | X-478          | <b>X-478</b>     | STARTER/BATT+ JUNCTION TERMINAL |
| Connector      | X-479B         | <b>X-479B</b>    |                                 |
| Connector      | X-480A         | <b>X-480A</b>    |                                 |
| Connector      | X-480B         | <b>X-480B</b>    |                                 |
| Connector      | X-481          | <b>X-481</b>     | ALT BATT+                       |
| Connector      | X-482A         | <b>X-482A</b>    |                                 |
| Connector      | X-482B         | <b>X-482B</b>    |                                 |
| Connector      | X-483A         | <b>X-483A</b>    |                                 |
| Connector      | X-483B         | <b>X-483B</b>    |                                 |
| Connector      | X-506B         | <b>X-506B</b>    |                                 |
| Connector      | X-507A         | <b>X-507A</b>    |                                 |
| Connector      | X-507B         | <b>X-507B</b>    |                                 |

## Wiring harnesses - Electrical schematic sheet 21 SH21 - COMFORT STEER/RIDE CONTROL

|  |                              |
|--|------------------------------|
| 580N FOUR-WHEEL DRIVE (4WD) TIER 4B (FINAL) [NGC730186 - ]     | Transmission - Power Shuttle |
| 580N TWO-WHEEL DRIVE (2WD) TIER 4B (FINAL) [NGC730186 - ]      | Transmission - Power Shuttle |
| 580SN FOUR-WHEEL DRIVE (4WD) TIER 4B (FINAL) [NGC732639 - ]    | Transmission - Power Shuttle |
| 580SN TWO-WHEEL DRIVE (2WD) TIER 4B (FINAL) [NGC732639 - ]     | Transmission - Power Shuttle |
| 580SN WT FOUR-WHEEL DRIVE (4WD) TIER 4B (FINAL) [NGC735098 - ] | Transmission - Power Shuttle |
| 590SN FOUR-WHEEL DRIVE (4WD) TIER 4B (FINAL) [NGC736228 - ]    | Transmission - Power Shuttle |
| 590SN TWO-WHEEL DRIVE (2WD) TIER 4B (FINAL) [NGC736228 - ]     | Transmission - Power Shuttle |

| Type      | Component     | Connector / Link | Description                          |
|-----------|---------------|------------------|--------------------------------------|
| Sensor    | <b>B-019</b>  | <b>X-600</b>     | PT SPEED SENSOR                      |
| Diode     | <b>D-001</b>  |                  | Diode                                |
| Fuse      | <b>F-001</b>  |                  | COMFORT STEER                        |
| Fuse      | <b>F-030</b>  |                  | COMFORT STEER                        |
| Relay     | <b>K-011</b>  |                  | COMFORT STEER BRAKE RELAY            |
| Relay     | <b>K-012</b>  |                  | AUTO RIDE CONTROL RELAY              |
| Switch    | <b>S-039</b>  | <b>X-024</b>     | RIDE CONTROL SWITCH                  |
| Switch    | <b>S-053</b>  | <b>X-142</b>     | COMFORT STEER SWITCH (FRONT CONSOLE) |
| Switch    | <b>S-054</b>  | <b>X-076</b>     | COMFORT STEER TRANSMISSION SWITCH    |
| Switch    | <b>SW-020</b> |                  |                                      |
| Switch    | <b>SW-040</b> | <b>X-511</b>     | RIDE CONTROL PRESSURE SWITCH         |
| Connector | X-001         | <b>X-001</b>     | INTERFACE TO SIDE HARNESS (X-051)    |
| Connector | X-012         | <b>X-012</b>     |                                      |
| Connector | X-013         | <b>X-013</b>     |                                      |
| Connector | X-014         | <b>X-014</b>     |                                      |
| Connector | X-024         | <b>X-024</b>     | RIDE CONTROL SW                      |
| Connector | X-028         | <b>X-028</b>     | CLUSTER                              |
| Connector | X-040         | <b>X-040</b>     | CONNECT TO X-150 (SIDE)              |
| Connector | X-051         | <b>X-051</b>     | CHASSIS (X-001)                      |
| Connector | X-052         | <b>X-052</b>     | RIDE CONTROL TANK SOL                |
| Connector | X-056         | <b>X-056</b>     | RIDE CONTROL ACCUM SOL               |
| Connector | X-058         | <b>X-058</b>     | COMFORT STEER                        |
| Connector | X-076         | <b>X-076</b>     | COMFORT STEER TRANS SW               |
| Connector | X-142         | <b>X-142</b>     | COMFORT STEER                        |
| Connector | X-150         | <b>X-150</b>     | CONNECT TO X-040 (FRONT)             |
| Connector | X-511         | <b>X-511</b>     | RIDE CONTROL PRESSURE SW             |
| Connector | X-600         | <b>X-600</b>     | PT SPEED SENS                        |
| Solenoid  | <b>Y-013</b>  | <b>X-056</b>     | RIDE CONTROL ACCUMULATOR SOLENOID    |
| Solenoid  | <b>Y-014</b>  | <b>X-052</b>     | RIDE CONTROL TANK SOLENOID           |
| Solenoid  | <b>Y-020</b>  | <b>X-058</b>     | COMFORT STEER SOLENOID               |

**Wiring harnesses - Electrical schematic sheet 08 SH08 - HYDRAULICS**

|  |  |
|--|--|
| 580N FOUR-WHEEL DRIVE (4WD) TIER 4B (FINAL) [NGC730186 - ]     | Transmission - Powershift transmission |
| 580N TWO-WHEEL DRIVE (2WD) TIER 4B (FINAL) [NGC730186 - ]      | Transmission - Powershift transmission |
| 580SN FOUR-WHEEL DRIVE (4WD) TIER 4B (FINAL) [NGC732639 - ]    | Transmission - Powershift transmission |
| 580SN TWO-WHEEL DRIVE (2WD) TIER 4B (FINAL) [NGC732639 - ]     | Transmission - Powershift transmission |
| 580SN WT FOUR-WHEEL DRIVE (4WD) TIER 4B (FINAL) [NGC735098 - ] | Transmission - Powershift transmission |
| 590SN FOUR-WHEEL DRIVE (4WD) TIER 4B (FINAL) [NGC736228 - ]    | Transmission - Powershift transmission |
| 590SN TWO-WHEEL DRIVE (2WD) TIER 4B (FINAL) [NGC736228 - ]     | Transmission - Powershift transmission |

| Type      | Component    | Connector / Link   | Description                           |
|-----------|--------------|--------------------|---------------------------------------|
| Fuse      | <b>F-028</b> |                    | BACKHOE COUPLERS                      |
| Switch    | <b>S-015</b> | <b>X-074 X-075</b> | RTD LIMIT SWITCH                      |
| Switch    | <b>S-016</b> | <b>X-034</b>       | B HOE QUICK COUPLER SWITCH A          |
| Switch    | <b>S-018</b> | <b>X-145</b>       | LOADER QUICK COUPLER SWITCH           |
| Connector | X-001        | <b>X-001</b>       | TO SIDE X-051                         |
| Connector | X-007        | <b>X-007</b>       | PWR OPT                               |
| Connector | X-012        | <b>X-012</b>       | GEP                                   |
| Connector | X-012B       | <b>X-012B</b>      |                                       |
| Connector | X-015        | <b>X-015</b>       | GEP                                   |
| Connector | X-015A       | <b>X-015A</b>      |                                       |
| Connector | X-034        | <b>X-034</b>       | BHOE QC SW                            |
| Connector | X-039        | <b>X-039</b>       | EH CLAM                               |
| Connector | X-040        | <b>X-040</b>       | CONNECT TO X-150 (SIDE)               |
| Connector | X-051        | <b>X-051</b>       | TO CHASSIS X-001                      |
| Connector | X-053        | <b>X-053</b>       | RTD SOL                               |
| Connector | X-059        | <b>X-059</b>       | BH QUICK CPLR SOL                     |
| Connector | X-060        | <b>X-060</b>       | LDR QUICK CPLR SOL                    |
| Connector | X-061        | <b>X-061</b>       | LOAD SENSE SOL                        |
| Connector | X-074        | <b>X-074</b>       | RTD LIMIT SW                          |
| Connector | X-075        | <b>X-075</b>       | RTD LIMIT SW                          |
| Connector | X-145        | <b>X-145</b>       | LOADER QC                             |
| Connector | X-150        | <b>X-150</b>       | TO FRONT (X-040)                      |
| Solenoid  | <b>Y-002</b> | <b>X-053</b>       | RETURN TO DIG SOLENOID                |
| Solenoid  | <b>Y-005</b> | <b>X-061</b>       | LOAD SENSE SOLENOID                   |
| Solenoid  | <b>Y-006</b> | <b>X-060</b>       | LOADER QUICK COUPLER RETRACT SOLENOID |
| Solenoid  | <b>Y-007</b> | <b>X-059</b>       | BHOE QUICK COUPLER RETRACT SOLENOID   |

## Wiring harnesses - Electrical schematic sheet 27 SH27 - PILOT CONTROLS INPUT

|  |  |
|--|--|
| 580N FOUR-WHEEL DRIVE (4WD) TIER 4B (FINAL) [NGC730186 - ]     | Transmission - Powershift transmission |
| 580N TWO-WHEEL DRIVE (2WD) TIER 4B (FINAL) [NGC730186 - ]      | Transmission - Powershift transmission |
| 580SN FOUR-WHEEL DRIVE (4WD) TIER 4B (FINAL) [NGC732639 - ]    | Transmission - Powershift transmission |
| 580SN TWO-WHEEL DRIVE (2WD) TIER 4B (FINAL) [NGC732639 - ]     | Transmission - Powershift transmission |
| 580SN WT FOUR-WHEEL DRIVE (4WD) TIER 4B (FINAL) [NGC735098 - ] | Transmission - Powershift transmission |
| 590SN FOUR-WHEEL DRIVE (4WD) TIER 4B (FINAL) [NGC736228 - ]    | Transmission - Powershift transmission |
| 590SN TWO-WHEEL DRIVE (2WD) TIER 4B (FINAL) [NGC736228 - ]     | Transmission - Powershift transmission |

| Type      | Component    | Connector / Link | Description                   |
|-----------|--------------|------------------|-------------------------------|
| Fuse      | <b>F-015</b> |                  | PILOT CONTROLS POWER          |
| Switch    | <b>S-029</b> | <b>X-409</b>     | RH STAB PRESSURE SWITCH       |
| Switch    | <b>S-035</b> | <b>X-426</b>     | L.H STAB PRESSURE SWITCH      |
| Switch    | <b>S-040</b> | <b>X-422</b>     | EHOE RETRACT PUSH BUTTON      |
| Switch    | <b>S-041</b> | <b>X-421</b>     | PILOT CONTROL HORN SWITCH     |
| Switch    | <b>S-052</b> |                  | EHOE EXTEND PUSH BUTTON       |
| Switch    | <b>S-053</b> |                  | BI-DIR AUX HYD REV B-PORT     |
| Switch    | <b>S-054</b> | <b>X-423</b>     | BI-DIR AUX HYD FWD A-PORT     |
| Switch    | <b>S-055</b> | <b>X-425</b>     | LH STAB SWITCH                |
| Switch    | <b>S-056</b> | <b>X-424</b>     | RH STAB SWITCH                |
| Switch    | <b>S-057</b> | <b>X-420</b>     | PILOT CONTROL ONE-TOUCH DECEL |
| Switch    | <b>S-058</b> | <b>X-418</b>     | PATTERN CHANGE SWITCH         |
| Switch    | <b>S-059</b> | <b>X-417</b>     | PILOT CONTROLS ON/OFF SWITCH  |
| Connector | X-001        | <b>X-001</b>     | TO SIDE X-051                 |
| Connector | X-012        | <b>X-012</b>     | GEP                           |
| Connector | X-012B       | <b>X-012B</b>    |                               |
| Connector | X-051        | <b>X-051</b>     | TO CHASSIS X-001              |
| Connector | X-054        | <b>X-054</b>     |                               |
| Connector | X-400        | <b>X-400</b>     |                               |
| Connector | X-409        | <b>X-409</b>     |                               |
| Connector | X-417        | <b>X-417</b>     |                               |
| Connector | X-418        | <b>X-418</b>     |                               |
| Connector | X-420        | <b>X-420</b>     |                               |
| Connector | X-421        | <b>X-421</b>     |                               |
| Connector | X-422        | <b>X-422</b>     |                               |
| Connector | X-423        | <b>X-423</b>     |                               |
| Connector | X-424        | <b>X-424</b>     |                               |
| Connector | X-425        | <b>X-425</b>     |                               |
| Connector | X-426        | <b>X-426</b>     |                               |
| Connector | X-455        | <b>X-455</b>     | CONNECTOR CONNECTS TO X-054   |

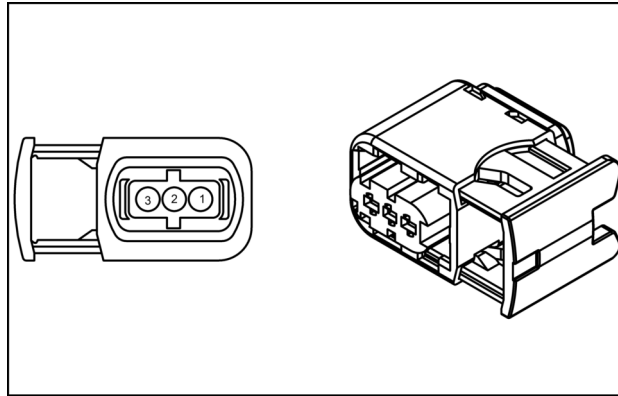

84146685 2

**Connector X-9113 - Glow plug control module**

Over 56kW (76hp) engines

| CONNECTOR X-9113 - Glow plug control module |             |                                |                            |
|---|-------------|--------------------------------|----------------------------|
| PIN NUMBER                                  | WIRE NUMBER | CIRCUIT REFERENCE              | ELECTRICAL SCHEMATIC FRAME |
| 1   | VE-9060     | Controlled supply, glow plug 3 | SHEET 02                   |
| 2   | VE-9058     | Controlled supply, glow plug 1 |                            |
| 3   | VE-9073     | Feedback signal                |                            |
| 4   | VE-9062     | Battery supply                 |                            |
| 5   | VE-9074     | Reference ground               |                            |
| 6   | VE-9061     | Controlled supply, glow plug 4 |                            |
| 7   | VE-9059     | Controlled supply, glow plug 2 |                            |
| 8   | VE-0972     | Control signal                 |                            |

Under 56kW (76hp) engines

| CONNECTOR X-9113 - Glow plug control module |             |                                |                            |
|---|-------------|--------------------------------|----------------------------|
| PIN NUMBER                                  | WIRE NUMBER | CIRCUIT REFERENCE              | ELECTRICAL SCHEMATIC FRAME |
| 1   | VE-9060     | Controlled supply, glow plug 3 | SHEET 02                   |
| 2   | VE-9058     | Controlled supply, glow plug 1 |                            |
| 3   | VE-9073     | Feedback signal                |                            |
| 4   | VE-9062     | Battery supply                 |                            |
| 5   | VE-9074     | Reference ground               |                            |
| 6   | VE-9061     | Controlled supply, glow plug 4 |                            |
| 7   | VE-9059     | Controlled supply, glow plug 2 |                            |
| 8   | VE-0971     | Control signal                 |                            |

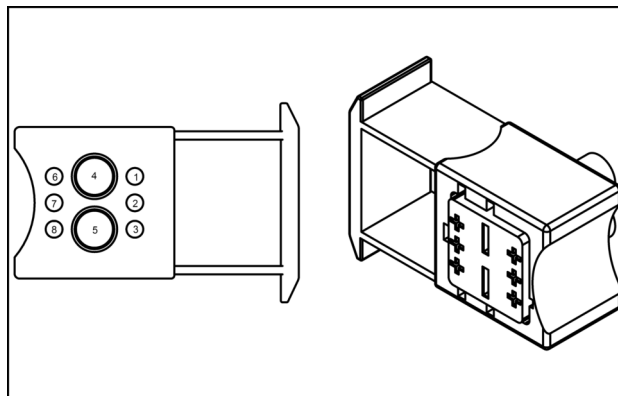

84356962 3



| Connector Number | Connector Name                          | Schematic Frame   |
|------------------|---|---|
| X-015            | Side Console Fuse                       | <p>Wiring harnesses - Electrical schematic sheet 02 Starting system (55.100)</p> <p>Wiring harnesses - Electrical schematic sheet 12 Instrument cluster (55.100)</p> <p>Wiring harnesses - Electrical schematic sheet 14 SAHR park brake (55.100)</p> <p>Wiring harnesses - Electrical schematic sheet 23 Trax SPS - PS controller (55.100)</p> <p>Wiring harnesses - Electrical schematic sheet 24 Hydraulic heavy lift (55.100)</p> <p>Wiring harnesses - Electrical schematic sheet 28 Diagnostic - CAN (55.100)</p> |
| X-018            | Side Console Fuse                       | <p>Wiring harnesses - Electrical schematic sheet 02 Starting system (55.100)</p> <p>Wiring harnesses - Electrical schematic sheet 14 SAHR park brake (55.100)</p> <p>Wiring harnesses - Electrical schematic sheet 20 Comfort steer / Ride control (55.100)</p>   |
| X-020            | Side harness to C-Post (X-500)          | Wiring harnesses - Electrical schematic sheet 17 Rear lights exterior (55.100)  |
| X-025            | Side Console Fuse                       | <p>Wiring harnesses - Electrical schematic sheet 02 Starting system (55.100)</p> <p>Wiring harnesses - Electrical schematic sheet 12 Instrument cluster (55.100)</p> <p>Wiring harnesses - Electrical schematic sheet 18 Options (55.100)</p>   |
| X-039            | EH Clam                                 | Wiring harnesses - Electrical schematic sheet 07 Hydraulics (55.100)  |
| X-043            | To Front brake switches connector X-044 | Wiring harnesses - Electrical schematic sheet 06 Powershift transmission inputs (55.100)  |
| X-101            | B-Post Harness Connector                | <p>Wiring harnesses - Electrical schematic sheet 10 Interior lighting (55.100)</p> <p>Wiring harnesses - Electrical schematic sheet 11 Wipers and washers (55.100)</p> <p>Wiring harnesses - Electrical schematic sheet 15 HVAC (55.100)</p> <p>Wiring harnesses - Electrical schematic sheet 17 Rear lights exterior (55.100)</p>  |
| X-102            | Speakers                                | Wiring harnesses - Electrical schematic sheet 16 Radio (55.100)   |
| X-103            | A/C Low Pressure Switch                 | Wiring harnesses - Electrical schematic sheet 15 HVAC (55.100)  |

## Wire connectors - Component diagram 06

|  |                              |
|--|------------------------------|
| 580N FOUR-WHEEL DRIVE (4WD) TIER 4B (FINAL) [NGC730186 - ]     | Transmission - Power Shuttle |
| 580N TWO-WHEEL DRIVE (2WD) TIER 4B (FINAL) [NGC730186 - ]      | Transmission - Power Shuttle |
| 580SN FOUR-WHEEL DRIVE (4WD) TIER 4B (FINAL) [NGC732639 - ]    | Transmission - Power Shuttle |
| 580SN TWO-WHEEL DRIVE (2WD) TIER 4B (FINAL) [NGC732639 - ]     | Transmission - Power Shuttle |
| 580SN WT FOUR-WHEEL DRIVE (4WD) TIER 4B (FINAL) [NGC735098 - ] | Transmission - Power Shuttle |
| 590SN FOUR-WHEEL DRIVE (4WD) TIER 4B (FINAL) [NGC736228 - ]    | Transmission - Power Shuttle |
| 590SN TWO-WHEEL DRIVE (2WD) TIER 4B (FINAL) [NGC736228 - ]     | Transmission - Power Shuttle |

### X-060 - LDR QUICK CPLR SOL [ Y-006] (87693821) (Receptacle)

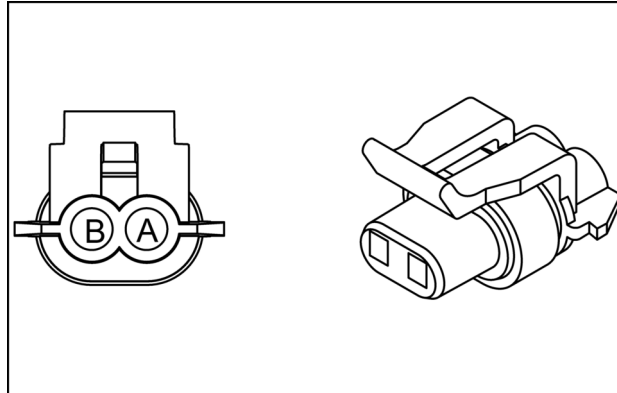

87693821 1

**87693821**

| Pin | From   | Wire | Description                                  | Color-Size | Frame    |
|-----|--|------|--|------------|----------|
| A   | X-001 pin 19 INTERFACE TO SIDE HARNESS (X-051) | 5023 | LOADER QUICK COUPLER RETRACT                 | WH - 0.5   | SHEET 08 |
| B   | SP-G07-P-X                                     | G024 | LOADER QUICK COUPLER RETRACT SOLENOID GROUND | BK - 0.5   |          |

### X-061 - LOAD SENSE SOL [ Y-005] (87691549) (Receptacle)

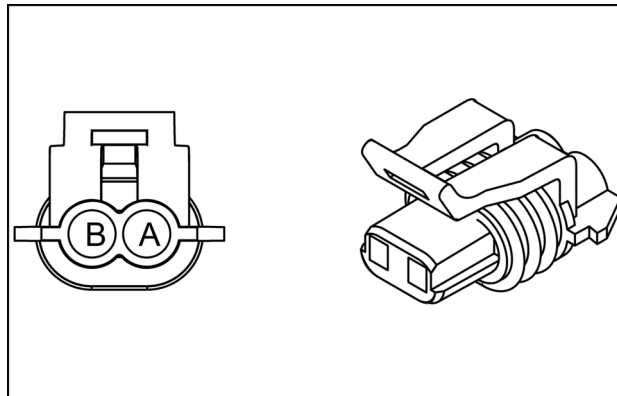

87691549 2

**87691549**

| Pin | From   | Wire | Description                              | Color-Size | Frame    |
|-----|--|------|--|------------|----------|
| A   | X-001 pin 28 INTERFACE TO SIDE HARNESS (X-051) | 5017 | QUICK COUPLER LOAD SENSE OUTPUT          | WH - 0.5   | SHEET 08 |
| B   | SP-G07-P-X                                     | G023 | QUICK COUPLER LOAD SENSE SOLENOID GROUND | BK - 0.5   |          |

**X-179 - [ E-034] (84120010) (Receptacle)**

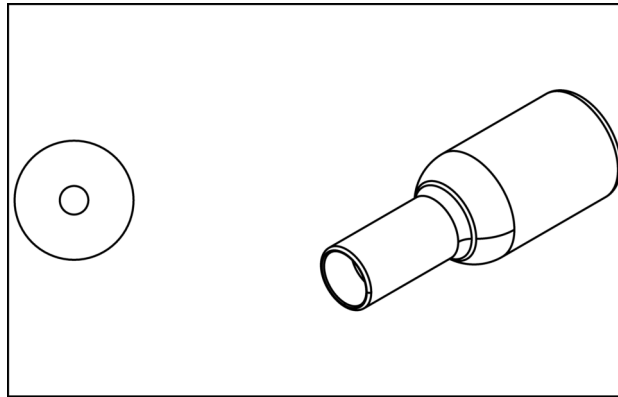

84120010 8

**84120010**

| Pin | From               | Wire | Description                       | Color-Size | Frame    |
|-----|--------------------|------|-----------------------------------|------------|----------|
| 1   | X-493 (Plug) pin 1 | G172 | FRONT RIGHT TURN<br>SIGNAL GROUND | BK - 0.5   | SHEET 25 |

| Pin | From                      | Wire | Description | Color-Size | Frame    |
|-----|---------------------------|------|-------------|------------|----------|
| 1   | X-461 (Receptacle) pin 28 | E280 | MAIN RELAY  | BL - 0.5   | SHEET 05 |
| 2   | SP-157-P-X                | 1015 | BAT+Â       | RD - 0.5   |          |
| 3   | SP-151-P-X                | E053 | BAT+        | RD - 6.0   |          |

**X-466 - [ F-038] (84177914) (Plug)**

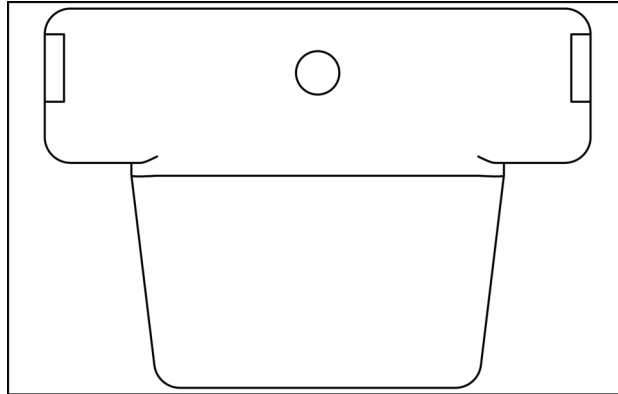

84177914 5  
**84177914**

| Pin | From       | Wire | Description | Color-Size | Frame    |
|-----|------------|------|-------------|------------|----------|
| 1   | SP-155-P-X | F2   | F2          | OR - 3.0   | SHEET 05 |
| 2   | SP-156-P-X | F1   | F1          | OR - 3.0   |          |

**X-469 - [ A-010] (84356962) (Receptacle)**

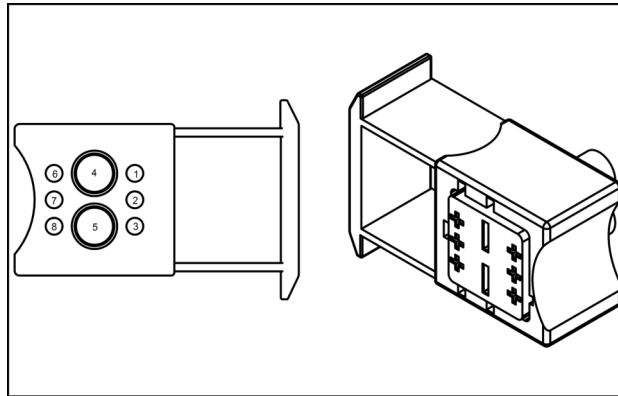

84356962 6  
**84356962**

| Pin | From                      | Wire | Description                   | Color-Size | Frame    |
|-----|---------------------------|------|-------------------------------|------------|----------|
| 1   | X-470 (Receptacle) pin 58 | 1580 | GLOW PLUG                     | WH - 2.0   | SHEET 05 |
| 2   | X-470 (Receptacle) pin 61 | 1610 | GLOW PLUG                     | WH - 2.0   |          |
| 3   | X-461 (Receptacle) pin 22 | E220 | GLOW PLUG FEEDBACK SIGNAL     | YE - 0.5   |          |
| 4   | SP-155-P-X                | 1040 | BAT+                          | RD - 6.0   |          |
| 5   | SP-203-P-X                | E411 | GLOW PLUG UNIT GND            | BK - 5.0   |          |
| 6   | X-470 (Receptacle) pin 57 | 1570 | GLOW PLUG                     | WH - 2.0   |          |
| 7   | X-470 (Receptacle) pin 60 | 1600 | GLOW PLUG                     | WH - 2.0   |          |
| 8   | X-461 (Receptacle) pin 26 | E520 | GLOW PLUG UNIT COMMAND SIGNAL | YE - 0.5   |          |

Electrical systems - Harnesses and connectors

| Pin | From  | Wire | Description                                    | Color-Size | Frame           |
|-----|---|------|--|------------|-----------------|
| 8   | <b>X-112 (Receptacle) pin 5</b><br>REAR LIGHTS SW     | AP58 | REAR LIGHTS KEY-ON                             | OR - 3.0   | <b>SHEET 18</b> |
| 9   | SP-033-P-X  | 42C8 | REAR WORK LIGHT                                | VT - 3.0   |                 |
| 10  | SP-G17-P-X  | G213 | REAR LIGHTS RELAY<br>COIL GROUND               | BK - 0.5   | <b>SHEET 04</b> |
| 12  | <b>X-184 (Plug) pin A</b> SEAT AIR<br>SUSPENSION      | 19N1 | AIR SUSPENSION SEAT<br>B+                      | RD - 1.0   | <b>SHEET 19</b> |
| 16  | SP-P001-P-X   | P016 | B+   | RD - 1.0   | <b>SHEET 02</b> |
| 17  | SP-038-P-X  | 5701 | COUPLERS/EH<br>CLAM/BOOM<br>LOCK/RADIO KEY-ON  | OR - 0.5   | <b>SHEET 08</b> |
| 18  | SP-AP02-P-X   | AP77 | WORK LIGHTS KEY ON<br>PWR                      | OR - 3.0   | <b>SHEET 18</b> |
| 19  | SP-099-P-X  | 41FB | FRONT DRIVING LIGHT                            | VT - 1.0   | <b>SHEET 10</b> |
| 20  | SP-P001-P-X   | P022 | B+   | RD - 0.5   | <b>SHEET 02</b> |
| 21  | SP-AP01-P-X   | AP06 | COUPLERS/EH CLAM/<br>BOOM LOCK/RADIO<br>KEY-ON | OR - 0.5   |                 |
| 22  | <b>X-012 (Receptacle) pin 2</b> GEP                   | AP59 | REAR WORK LIGHT                                | OR - 3.0   | <b>SHEET 18</b> |
| 23  | SP-032-P-X  | 41R7 | TAIL LIGHT                                     | VT - 1.0   |                 |
| 24  | <b>X-020 (Receptacle) pin C5</b><br>TO B-POST (X-101) | 9302 | RADIO B+                                       | RD - 0.5   | <b>SHEET 17</b> |
| 25  | SP-AP01-P-X   | AP02 | REAR WIPER/WASHER<br>KEY-ON                    | OR - 0.8   | <b>SHEET 02</b> |
| 26  | SP-012-P-X  | 3P02 | CRANK SIGNAL                                   | OR - 0.5   | <b>SHEET 03</b> |
| 27  | SP-AP01-P-X   | AP03 | 4WD/RIDE CONTROL<br>KEY-ON                     | OR - 0.5   | <b>SHEET 02</b> |
| 28  | SP-P001-P-X   | P029 | B+   | RD - 0.5   |                 |
| 29  | SP-006-P-X  | 63R1 | REAR WIPER/WASHER<br>KEY-ON                    | OR - 0.8   | <b>SHEET 12</b> |
| 30  | <b>X-498 (Receptacle) pin 2</b><br>TELEMATICS MODULE  | 3P03 | CRANK SIGNAL                                   | OR - 0.5   | <b>SHEET 34</b> |
| 31  | SP-042-P-X  | AP38 | 4WD/RIDE CONTROL<br>KEY-ON                     | OR - 0.5   | <b>SHEET 07</b> |
| 32  | SP-057-P-X  | 64A1 | HORN B+  | RD - 0.5   | <b>SHEET 20</b> |
| 33  | SP-AP01-P-X   | AP07 | COMFORT STEER<br>KEY-ON                        | OR - 0.5   | <b>SHEET 02</b> |
| 34  | <b>X-221 (Receptacle) pin 1</b><br>THERMOSTAT SW      | 8502 | A/C COMPRESSOR<br>SOLENOID POWER               | BR - 0.5   | <b>SHEET 16</b> |
| 35  | SP-AP01-P-X   | AP42 | PILOT CONTROLS<br>KEY-ON                       | OR - 0.8   | <b>SHEET 02</b> |
| 36  | SP-P001-P-X   | P015 | B+   | RD - 0.5   |                 |
| 37  | <b>X-150 pin 33</b> TO FRONT<br>(X-040)               | 0901 | COMFORT STEER<br>KEY-ON                        | OR - 0.5   | <b>SHEET 21</b> |
| 38  | <b>X-022 pin 1</b> BLOWER SW                          | 8501 | A/C COMPRESSOR<br>SOLENOID POWER               | BR - 3.0   | <b>SHEET 16</b> |
| 39  | <b>X-051 pin 25</b> TO CHASSIS<br>X-001               | AP43 | PILOT CONTROLS<br>KEY-ON                       | OR - 0.8   | <b>SHEET 27</b> |
| 40  | <b>X-020 (Receptacle) pin C7</b><br>TO B-POST (X-101) | 0491 | DOME LIGHT B+                                  | RD - 0.5   | <b>SHEET 11</b> |
| 41  | SP-AP01-P-X   | AP04 | HVAC KEY-ON                                    | OR - 3.0   | <b>SHEET 02</b> |
| 42  | SP-P001-P-X   | P014 | B+   | RD - 2.0   |                 |
| 43  | SP-AP02-P-X   | AP46 | SIDE LIGHTS KEY-ON                             | OR - 2.0   | <b>SHEET 18</b> |
| 44  | SP-040-P-X  | 8403 | CIGARETTE LIGHTER B+                           | RD - 3.0   | <b>SHEET 14</b> |
| 45  | <b>X-022 pin 2</b> BLOWER SW                          | AP08 | HVAC KEY-ON                                    | OR - 3.0   | <b>SHEET 16</b> |
| 46  | <b>X-018 (Plug) pin 14</b> GEP                        | P032 | B+   | RD - 2.0   | <b>SHEET 03</b> |
| 47  | <b>X-112 (Receptacle) pin 2</b><br>REAR LIGHTS SW     | AP47 | SIDE LIGHTS KEY-ON                             | OR - 2.0   | <b>SHEET 18</b> |
| 48  | SP-P001-P-X   | P017 | B+   | RD - 3.0   | <b>SHEET 02</b> |

## Wire connectors - Component diagram 12

|  |  |
|--|--|
| 580N FOUR-WHEEL DRIVE (4WD) TIER 4B (FINAL) [NGC730186 - ]     | Transmission - Powershift transmission |
| 580N TWO-WHEEL DRIVE (2WD) TIER 4B (FINAL) [NGC730186 - ]      | Transmission - Powershift transmission |
| 580SN FOUR-WHEEL DRIVE (4WD) TIER 4B (FINAL) [NGC732639 - ]    | Transmission - Powershift transmission |
| 580SN TWO-WHEEL DRIVE (2WD) TIER 4B (FINAL) [NGC732639 - ]     | Transmission - Powershift transmission |
| 580SN WT FOUR-WHEEL DRIVE (4WD) TIER 4B (FINAL) [NGC735098 - ] | Transmission - Powershift transmission |
| 590SN FOUR-WHEEL DRIVE (4WD) TIER 4B (FINAL) [NGC736228 - ]    | Transmission - Powershift transmission |
| 590SN TWO-WHEEL DRIVE (2WD) TIER 4B (FINAL) [NGC736228 - ]     | Transmission - Powershift transmission |

### X-121 - (Receptacle)

### X-122 - PWR TO SIDE (X-123) [ SH2: B-6] (47761027) (Plug)

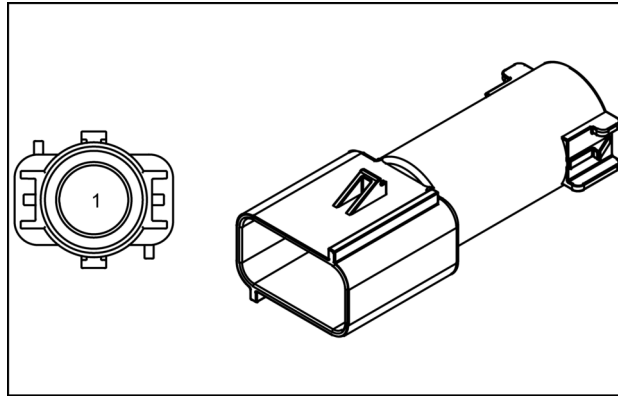

47761027 1  
**47761027**

### X-123 - TO CHASSIS (X-122) (84364890) (Receptacle)

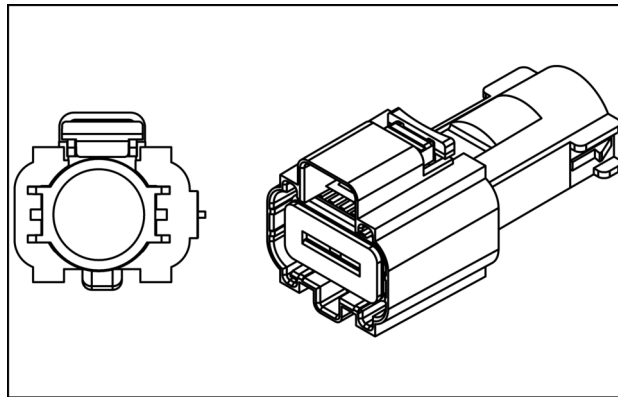

84364890 2  
**84364890**

| Pin | From                                  | Wire | Description | Color-Size | Frame           |
|-----|---------------------------------------|------|-------------|------------|-----------------|
| 1   | X-015 pin 36 GEP                      | P027 | B+          | RD - 3.0   | <b>SHEET 02</b> |
| 1   | SP-102-P-X                            | P009 | B+          | RD - 2.0   |                 |
| 1   | X-016 (Receptacle) pin 5<br>PWR RLY 1 | P005 | B+          | RD - 8.0   |                 |
| 1   | X-017 (Receptacle) pin 5<br>PWR RLY 2 | P008 | B+          | RD - 8.0   |                 |
| 1   | SP-AP04-P-X                           | P006 | B+          | RD - 2.0   |                 |
| 1   | SP-P001-P-X                           | P010 | B+          | RD - 8.0   |                 |

## Wire connectors - Component diagram 27

|  |  |
|--|--|
| 580N FOUR-WHEEL DRIVE (4WD) TIER 4B (FINAL) [NGC730186 - ]     | Transmission - Powershift transmission |
| 580N TWO-WHEEL DRIVE (2WD) TIER 4B (FINAL) [NGC730186 - ]      | Transmission - Powershift transmission |
| 580SN FOUR-WHEEL DRIVE (4WD) TIER 4B (FINAL) [NGC732639 - ]    | Transmission - Powershift transmission |
| 580SN TWO-WHEEL DRIVE (2WD) TIER 4B (FINAL) [NGC732639 - ]     | Transmission - Powershift transmission |
| 580SN WT FOUR-WHEEL DRIVE (4WD) TIER 4B (FINAL) [NGC735098 - ] | Transmission - Powershift transmission |
| 590SN FOUR-WHEEL DRIVE (4WD) TIER 4B (FINAL) [NGC736228 - ]    | Transmission - Powershift transmission |
| 590SN TWO-WHEEL DRIVE (2WD) TIER 4B (FINAL) [NGC736228 - ]     | Transmission - Powershift transmission |

### X-274 - HYD MODE SW [ S-046] (84159859) (Receptacle)

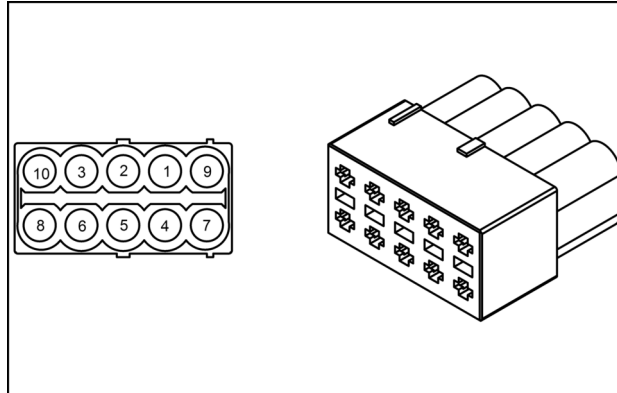

84159859 1

**84159859**

| Pin | From                             | Wire | Description                              | Color-Size | Frame           |
|-----|----------------------------------|------|--|------------|-----------------|
| 1   | X-051 pin 34 TO CHASSIS<br>X-001 | G150 | COMBO HYD. SWITCH<br>GROUND              | BK - 0.5   | <b>SHEET 26</b> |
| 2   | X-051 pin 14 TO CHASSIS<br>X-001 | 0729 | COMBO HYDRAULICS<br>SIGNAL               | BL - 0.5   |                 |
| 4   | X-051 pin 3 TO CHASSIS<br>X-001  | 0738 | HAMMER VALVE POWER                       | WH - 0.5   |                 |
| 5   | X-051 pin 15 TO CHASSIS<br>X-001 | 0737 | AUX FORWARD OF<br>HAMMER VALVE<br>OUTPUT | YE - 0.5   |                 |
| 6   | X-051 pin 12 TO CHASSIS<br>X-001 | 0732 | AUX FORWARD OUTPUT                       | WH - 0.5   |                 |

### X-275 - HEAVY LIFT SOL [ SH4: C-1] (84277193) (Receptacle)

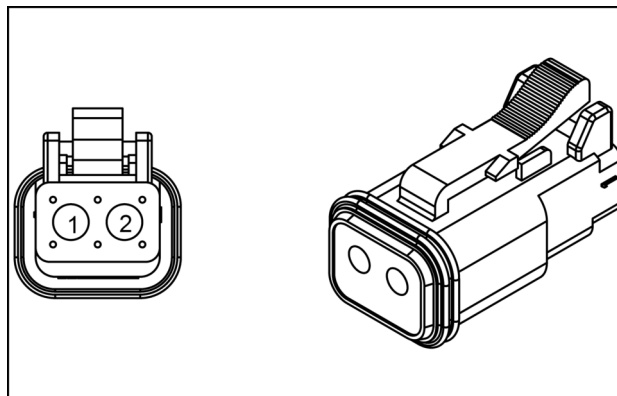

84277193 2

**84277193**

| Pin | From       | Wire | Description                   | Color-Size | Frame           |
|-----|------------|------|-------------------------------|------------|-----------------|
| 1   | SP-212-P-X | 0718 | HEAVY LIFT OUTPUT             | WH - 0.5   | <b>SHEET 25</b> |
| 2   | SP-G07-P-X | G110 | HEAVY LIFT SOLENOID<br>GROUND | BK - 0.5   | <b>SHEET 04</b> |

## Wire connectors - Component diagram 44

|  |  |
|--|--|
| 580N FOUR-WHEEL DRIVE (4WD) TIER 4B (FINAL) [NGC730186 - ]     | Transmission - Powershift transmission |
| 580N TWO-WHEEL DRIVE (2WD) TIER 4B (FINAL) [NGC730186 - ]      | Transmission - Powershift transmission |
| 580SN FOUR-WHEEL DRIVE (4WD) TIER 4B (FINAL) [NGC732639 - ]    | Transmission - Powershift transmission |
| 580SN TWO-WHEEL DRIVE (2WD) TIER 4B (FINAL) [NGC732639 - ]     | Transmission - Powershift transmission |
| 580SN WT FOUR-WHEEL DRIVE (4WD) TIER 4B (FINAL) [NGC735098 - ] | Transmission - Powershift transmission |
| 590SN FOUR-WHEEL DRIVE (4WD) TIER 4B (FINAL) [NGC736228 - ]    | Transmission - Powershift transmission |
| 590SN TWO-WHEEL DRIVE (2WD) TIER 4B (FINAL) [NGC736228 - ]     | Transmission - Powershift transmission |

### X-441 - HAMMER VALVE LH JOYSTICK SWITCH (87695584) (Plug)

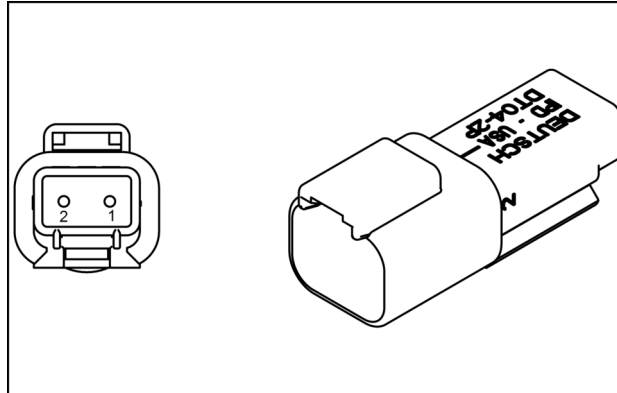

87695584 1

**87695584**

### X-442 - HAMMER VALVE OPTION HARNESS CONN (87698254) (Plug)

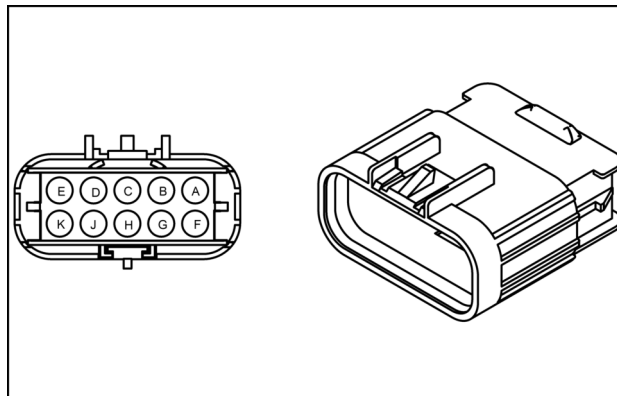

87698254 2

**87698254**

### X-443 - HAMMER VALVE OPTION HARNESS CON (87693431) (Plug)

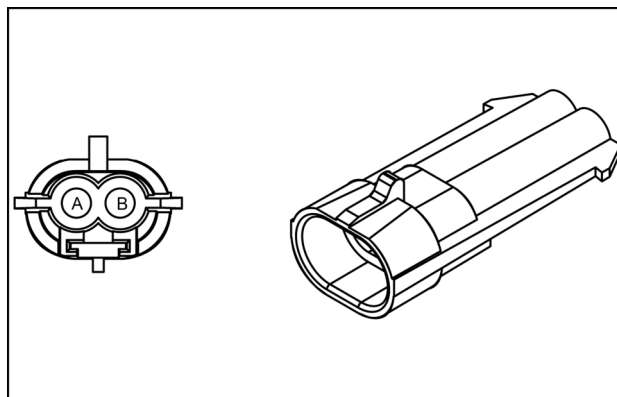

87693431 3

**87693431**

**X-535 - TELEMATICS BATT+ TO DISCONNECT S (47761013) (Plug)**

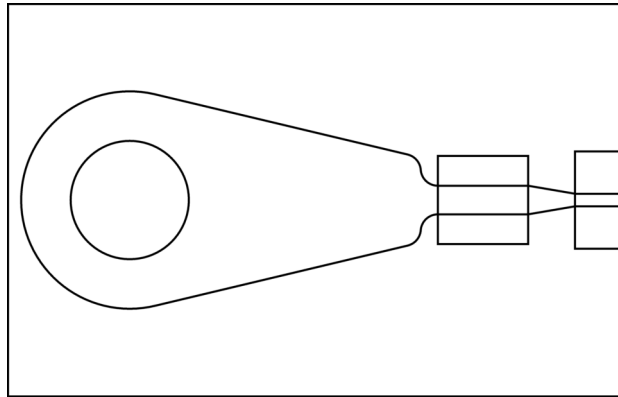

47761013 3  
**47761013**

| Pin | From       | Wire | Description   | Color-Size | Frame           |
|-----|------------|------|---------------|------------|-----------------|
| 1   | SP-218-P-X | 1024 | TELEMATICS B+ | RD - 8.0   | <b>SHEET 34</b> |

**X-536 - CCV HEATER RECEP [ A-021] (87695909) (Receptacle)**

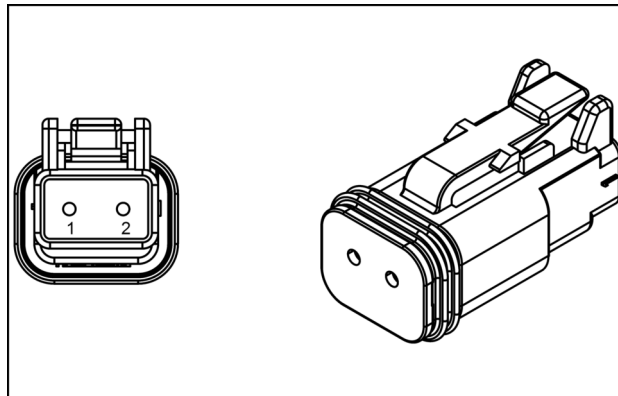

87695909 4  
**87695909**

| Pin | From                       | Wire | Description | Color-Size | Frame           |
|-----|----------------------------|------|-------------|------------|-----------------|
| 1   | <b>X-448 (Plug) pin 16</b> | E005 | B+          | RD - 1.0   | <b>SHEET 05</b> |
| 2   | SP-153-P-X                 | G345 | GND         | BK - 1.0   |                 |

## Electrical components - Resistor description

|  |                              |
|--|------------------------------|
| 580N FOUR-WHEEL DRIVE (4WD) TIER 4B (FINAL) [NGC730186 - ]     | Transmission - Power Shuttle |
| 580N TWO-WHEEL DRIVE (2WD) TIER 4B (FINAL) [NGC730186 - ]      | Transmission - Power Shuttle |
| 580SN FOUR-WHEEL DRIVE (4WD) TIER 4B (FINAL) [NGC732639 - ]    | Transmission - Power Shuttle |
| 580SN TWO-WHEEL DRIVE (2WD) TIER 4B (FINAL) [NGC732639 - ]     | Transmission - Power Shuttle |
| 580SN WT FOUR-WHEEL DRIVE (4WD) TIER 4B (FINAL) [NGC735098 - ] | Transmission - Power Shuttle |
| 590SN FOUR-WHEEL DRIVE (4WD) TIER 4B (FINAL) [NGC736228 - ]    | Transmission - Power Shuttle |
| 590SN TWO-WHEEL DRIVE (2WD) TIER 4B (FINAL) [NGC736228 - ]     | Transmission - Power Shuttle |

### **R-001 - BLOWER MOTOR RESISTANCE (Resistor)**

|                |                 |
|----------------|-----------------|
| Component Type | Resistor        |
| Wiring frames  | <b>SHEET 16</b> |

### **RES-001 - (Resistor)**

|                |                 |
|----------------|-----------------|
| Component Type | Resistor        |
| Wiring frames  | <b>SHEET 13</b> |

### **RES-003 - BLOWER RESISTOR (Resistor)**

|                |                 |
|----------------|-----------------|
| Component Type | Resistor        |
| Wiring frames  | <b>SHEET 16</b> |

### **RES-004 - BLOWER RESISTOR (Resistor)**

|                |                 |
|----------------|-----------------|
| Component Type | Resistor        |
| Wiring frames  | <b>SHEET 16</b> |

## Electrical components - Lamp description

|  |  |
|--|--|
| 580N FOUR-WHEEL DRIVE (4WD) TIER 4B (FINAL) [NGC730186 - ]     | Transmission - Powershift transmission |
| 580N TWO-WHEEL DRIVE (2WD) TIER 4B (FINAL) [NGC730186 - ]      | Transmission - Powershift transmission |
| 580SN FOUR-WHEEL DRIVE (4WD) TIER 4B (FINAL) [NGC732639 - ]    | Transmission - Powershift transmission |
| 580SN TWO-WHEEL DRIVE (2WD) TIER 4B (FINAL) [NGC732639 - ]     | Transmission - Powershift transmission |
| 580SN WT FOUR-WHEEL DRIVE (4WD) TIER 4B (FINAL) [NGC735098 - ] | Transmission - Powershift transmission |
| 590SN FOUR-WHEEL DRIVE (4WD) TIER 4B (FINAL) [NGC736228 - ]    | Transmission - Powershift transmission |
| 590SN TWO-WHEEL DRIVE (2WD) TIER 4B (FINAL) [NGC736228 - ]     | Transmission - Powershift transmission |

### **LMP-008 - Lamp (Lamp)**

|                |                 |
|----------------|-----------------|
| Component Type | Lamp            |
| Wiring frames  | <b>SHEET 19</b> |

### **LMP-025 - Lamp (Lamp)**

|                |                 |
|----------------|-----------------|
| Component Type | Lamp            |
| Wiring frames  | <b>SHEET 18</b> |

7. Remove the nut and washer (1).

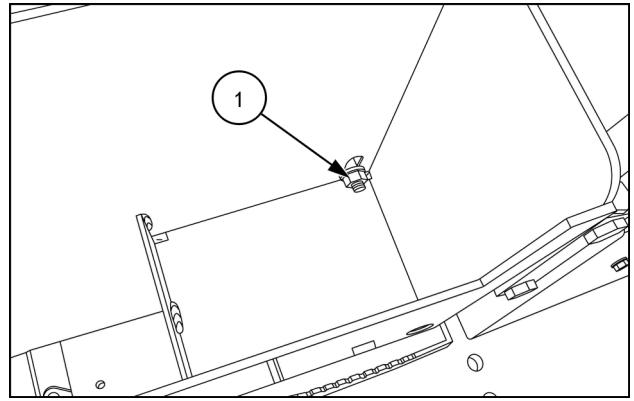

RAIL14TLB1294AA 4

8. Remove the two bolts and washers (1) from the bottom.

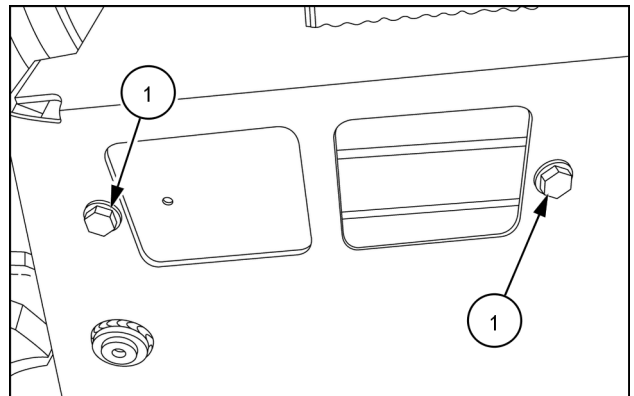

RAIL14TLB1296AA 5

9. Lean the storage box forward off of the stud.

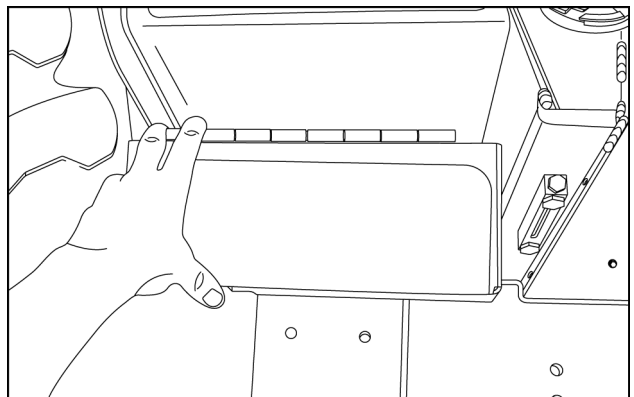

RAIL14TLB1297AA 6

10. Remove the storage box.

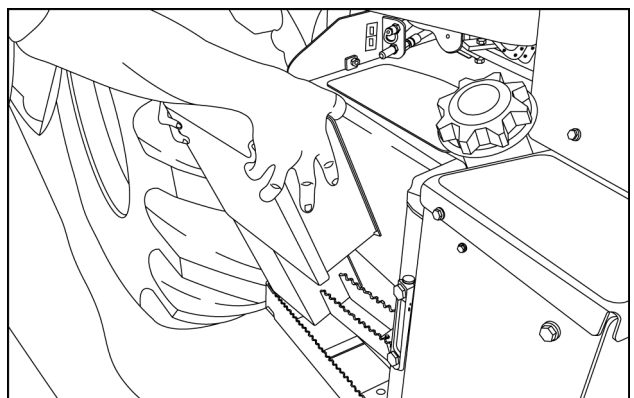

RAIL14TLB1298AA 7

|                                      |   |
|--------------------------------------|---|
| <b>Expected Result</b>               | <b>Result</b><br>The connections are secure. The connections are free of corrosion, abrasion, and damage.                             |
| <b>Other Result (Possible Cause)</b> | <b>Action</b><br>The connections are not secure or the connections show signs of corrosion, abrasion, and damage. Repair as required. |

|                                      |  |
|--------------------------------------|--|
| <b>Test N°2</b>                      |  |
| <b>Test Point</b>                    | <b>Condition</b><br>Turn the ignition switch OFF.<br><b>Check</b><br>Measure the resistance between the flasher relay connection X-010 pin 4 and chassis ground. |
| <b>Expected Result</b>               | <b>Result</b><br>The resistance should be less than <b>10 Ω</b> . Wiggle the harness during measurement to reveal an intermittent condition.                     |
| <b>Other Result (Possible Cause)</b> | <b>Action</b><br>The resistance is greater than <b>10 Ω</b> there is a problem in the ground circuit to the relay. Repair as required.                           |

|                                      |  |
|--------------------------------------|--|
| <b>Test N°3</b>                      |  |
| <b>Test Point</b>                    | <b>Condition</b><br>Turn the ignition switch OFF.<br><b>Check</b><br>Measure the resistance between the flasher relay connection X-010 pin 3 to the turn signal indicator connector X-138 pin 2. Measure the resistance between flasher relay connection X-010 pin 6 and the turn signal indicator X-138 pin 3. Wiggle the harness during measurement to reveal an intermittent condition. |
| <b>Expected Result</b>               | <b>Result</b><br>The resistance should be less than <b>10 Ω</b> .  |
| <b>Other Result (Possible Cause)</b> | <b>Action</b><br>The resistance is greater than <b>10 Ω</b> there is a problem in the wiring from the flasher relay to the turn signal indicator. Repair as required.  |

|                                      |  |
|--------------------------------------|--|
| <b>Test N°4</b>                      |  |
| <b>Test Point</b>                    | <b>Condition</b><br>Turn the ignition switch ON.<br><b>Check</b><br>Measure the voltage between the flasher relay connection X-010 pin 2 and chassis ground. |
| <b>Expected Result</b>               | <b>Result</b><br>The voltage should be approximately <b>12 V</b> .   |
| <b>Other Result (Possible Cause)</b> | <b>Action</b><br>The voltage is less than <b>10 V</b> there is a problem in the battery supply to the relay. Check fuse F-014. Repair as required.           |

|                                      |  |
|--------------------------------------|--|
| <b>Test N°5</b>                      |  |
| <b>Test Point</b>                    | <b>Condition</b><br>Turn the ignition switch ON. Fabricate a jumper wire approximately <b>20 cm (8 in)</b> .<br><b>Check</b><br>Use the jumper wire to short X-010 pin 2 to X-010 pin 1. |
| <b>Expected Result</b>               | <b>Result</b><br>The hazard lights should light while the jumper is in place.  |
| <b>Other Result (Possible Cause)</b> | <b>Action</b><br>The hazard lights did not light. Temporarily replace the flasher relay and retest.  |

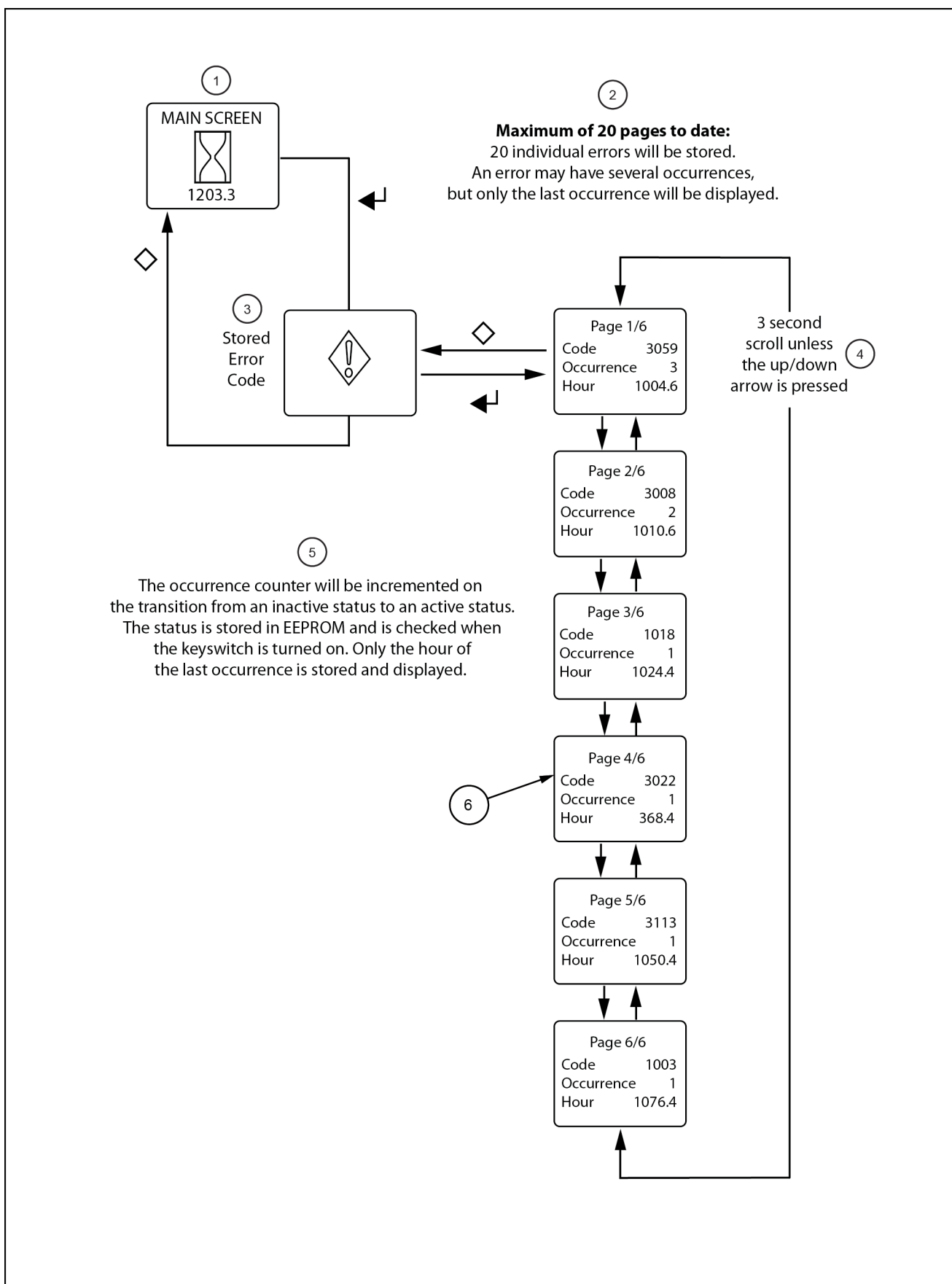

|   |     |
|---|-----|
| 17337-Hydrocarbon level 2 exceeded [ECU] .....  | 611 |
| 17345-CAN communication failure between vehicle controller and ECU controller - TSC1_PE message ..... | 612 |
| 17347-No load error for Low Voltage System .....  | 614 |
| 17348-Over temperature error on ECU powerstage for Glow plug Low Voltage System .....                 | 616 |
| 17349-Short circuit to battery error for Low Voltage System .....                                     | 618 |
| 17350-Short circuit to ground error for Low Voltage System .....                                      | 620 |
| 17359-Glow plug 1 control circuit shorted to ground .....   | 622 |
| 17360-Glow plug 3 control circuit shorted to ground .....   | 624 |
| 17361-Glow plug 4 control circuit shorted to ground .....   | 626 |
| 17362-Glow plug 2 control circuit shorted to ground .....   | 628 |
| 17377-MI1 injection quantity is low .....   | 630 |
| 17378-MI1 energizing time is low .....  | 631 |
| 17379-Measured injection closing time exceeds a limit .....   | 632 |
| 17380-Measured injection closing time exceeds a limit .....   | 633 |
| 17381-Measured injection closing time exceeds a limit .....   | 634 |
| 17382-Measured injection closing time exceeds a limit .....   | 635 |
| 17383-IMA type mismatch .....   | 636 |
| 17384-IMA type mismatch .....   | 637 |
| 17385-IMA type mismatch .....   | 638 |
| 17386-IMA type mismatch .....   | 639 |
| 17387-Chip error in the Injector CY33x power stage component .....                                    | 640 |
| 17403-Reporting Error if Relay is stuck at closed position .....                                      | 641 |
| 17404-Reporting Error if Relay is stuck at open position .....  | 643 |
| 17405-DFC used to evaluate filter clog .....  | 645 |
| 17409-Reporting the leakage in the system during no dosing .....                                      | 646 |
| 17410-Error in dosing valve plausibility at low voltage .....   | 647 |
| 17411-Defective pressure reduction .....  | 649 |
| 17412-High threshold for pressure sensor plausibility .....   | 650 |
| 17413-Low threshold for pressure sensor plausibility .....  | 651 |
| 17414-DEF/AdBlue Supply module supply voltage control relay circuit open .....                        | 652 |
| 17415-DEF/AdBlue Supply module supply voltage control relay short circuit .....                       | 654 |
| 17416-DEF/AdBlue Supply module supply voltage control relay short circuit to battery .....            | 656 |
| 17417-DEF/AdBlue Supply module supply voltage control relay short circuit to ground .....             | 658 |
| 17420-SRC high for Urea Pump Module Pressure Sensor .....   | 659 |
| 17421-SRC low for Urea Pump Module Pressure Sensor .....  | 660 |
| 17422-Timer error of ECU off time counter .....   | 661 |
| 17427-SRC high for air temperature sensor .....   | 662 |
| 17428-SRC low for air temperature sensor .....  | 664 |
| 17429-DFC is set if the cold start is detected .....  | 666 |
| 17442-Permanent governor deviation for valve .....  | 667 |
| 17443-Permanent governor deviation for valve .....  | 668 |
| 17444-Open load error for powerstage .....  | 669 |

## 1020-Transmission Oil Is Above Operating Temperature

### Context:

The transmission oil temperature is greater than **105 °C (221 °F)** for a period greater than **5 s**.

### Cause:

The transmission oil temperature is greater than **105 °C (221 °F)** for a period greater than **5 s**.

### Solution:

1. This is an information fault code only. The fault code is logged and indicates that the transmission oil temperature is approaching the fault code trigger point.
2. Verify proper transmission oil level.
3. Fault Code **1020 - Transmission Oil Is Above Operating Temperature** is a CAN data link message from the ECU to the instrument cluster. This fault code is displayed on the instrument cluster to warn the operator of a high transmission oil temperature warning.

**Wiring harnesses - Electrical schematic sheet 13 SH13 - INSTRUMENT CLUSTER (55.100.DP-C.20.E.13)**

**Wiring harnesses - Electrical schematic sheet 13 SH13 - INSTRUMENT CLUSTER (55.100.DP-C.20.E.13)**

## 1035-Hand throttle sensor signal above range

### Context:

The instrument cluster detects a throttle signal greater than **4.75 V** on the hand throttle signal line (connector X-29, pin 17). The instrument cluster will illuminate the warning lamp  and will sound the alarm for one second on the next system power up following the event.

### Cause:

The instrument cluster detects a throttle signal greater than **4.75 V** on the hand throttle signal line (connector X-29, pin 17).

### Possible failure modes:

1. Faulty wiring or connections from the instrument cluster to the throttle sensor.
2. A faulty throttle sensor.
3. A faulty instrument cluster.

### Solution:

1. Verify that the fault code is active.

Connect the Electronic Service Tool to the service tool connector.

To check for fault codes: Start and operate the machine.

A. The fault code is not recorded again. OK to return the machine to service.

B. Fault code 1035 is recorded again. Go to step 2.

2. Verify that the wiring and connectors are free of damage.

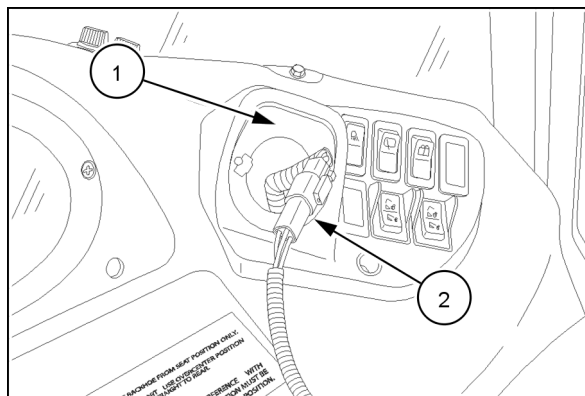

BD08E041-01 1

|   |                                |   |                         |
|---|--------------------------------|---|-------------------------|
| 1 | Location of the hand throttle. | 2 | Hand throttle connector |
|---|--------------------------------|---|-------------------------|

Inspect the instrument cluster and the hand throttle connections. All connections should be secure, tight, free of corrosion, abrasion, and damage.

Inspect the harness between the instrument cluster to the hand throttle. Verify that the harness is free of damage, corrosion, abrasion or incorrect attachment.

- B. The harness is damaged or the connectors are loose or damaged. Repair or replace the harness or the connectors as required. Return to step **1** to confirm elimination of the fault.
- C. One or both resistance measurements are less than **108  $\Omega$**  or greater than **132  $\Omega$** . Replace the control module that has the bad resistance value. Return to step **1** to confirm elimination of fault.

B. If you do not find damage and the display indicates only normal readings, then erase the fault code and continue operation.

**Wiring harnesses - Electrical schematic sheet 06 SH06 - ENGINE CONTROL (55.100.DP-C.20.E.06)**

**Wiring harnesses - Electrical schematic sheet 06 SH06 - ENGINE CONTROL (55.100.DP-C.20.E.06)**

- A. If you find damage or the display indicates other than normal display readings, then repair the damage discovered during the inspection or locate and repair the other than normal display condition and verify that the error has been resolved.
- B. If you do not find damage and the display indicates only normal readings, then erase the fault code and continue operation.

**Wiring harnesses - Electrical schematic sheet 05 SH05 - ENGINE CONTROL (55.100.DP-C.20.E.05)**

**Wiring harnesses - Electrical schematic sheet 06 SH06 - ENGINE CONTROL (55.100.DP-C.20.E.06)**

**Wiring harnesses - Electrical schematic sheet 05 SH05 - ENGINE CONTROL (55.100.DP-C.20.E.05)**

**Wiring harnesses - Electrical schematic sheet 06 SH06 - ENGINE CONTROL (55.100.DP-C.20.E.06)**

## 3208-Open load error of injector in cylinder 2

### Context:

The Engine Control Unit (ECU) monitors the fuel injector number 2 circuit. If the ECU determines that there is an open circuit condition in the fuel injector number 2 circuit, this fault will occur.

### Cause:

The ECU has detected an open circuit in the fuel injector number 2 circuit.

### Possible failure modes:

1. An internal failure within fuel injector number 2.
2. An open circuit in the wiring for fuel injector number 2.
3. A faulty ECU.

### Solution:

1. Verify fault is present and active.

Use the Electronic Service Tool (EST) to check the status of this fault.

A. If the fault is present and active, continue with step 2.

B. If the fault is no longer present or in an inactive state, the fault may be intermittent and not currently active. Continue with step 5.

2. Check fuel injector number 2 for an internal failure.

Disconnect fuel injector number 2.

Use a multimeter to perform the following resistance check on the fuel injector pins :

| From                         | To                           | Value  |
|------------------------------|------------------------------|--|
| Fuel injector number 2 pin 1 | Fuel injector number 2 pin 1 | There should be approximately <b>0.3 - 0.5 Ω</b> . |

A. If the resistance is significantly greater than the specified range, the fuel injector has failed. Replace the fuel injector number 2 and retest.

B. If the specified range is measured, leave fuel injector number 2 disconnected and continue to step 3.

3. Check the fuel injector number 2 injector harness wiring for an open circuit.

Disconnect connector **X-471 X-471** from the engine interface connector.

Use a multimeter to perform the following continuity check on the engine harness side :

| From   | To                                     | Value                       |
|--|--|-----------------------------|
| <b>X-471 (Receptacle) pin H X-471 (Receptacle) pin H</b> | Fuel injector number 2 connector pin 1 | There should be continuity. |
| <b>X-471 (Receptacle) pin G X-471 (Receptacle) pin G</b> | Fuel injector number 2 connector pin 2 | There should be continuity. |

A. If there is no continuity, there is an open circuit in the fuel injector number 2 injector harness wiring. Locate and repair the broken conductor. Repair or replace the harness as required.

B. If there is continuity, leave fuel injector number 2 disconnected. Leave connector **X-471 X-471** disconnected and continue to step 4.

4. Check the fuel injector number 2 vehicle harness wiring for an open circuit.

Disconnect the vehicle harness from the ECU at connector **X-462 X-462**.

B. If the voltage is not present for one or more of the checks, then locate and restore supply power to the ECU. Repair or replace the harness as required.

4. Check the ECU ground connections.

Use a multimeter to check for continuity on the vehicle harness side :

| From   | To             | Value                       |
|--|----------------|-----------------------------|
| <b>X-461 (Receptacle) pin 2 X-461 (Receptacle) pin 2</b> | Chassis ground | There should be continuity. |
| <b>X-461 (Receptacle) pin 4 X-461 (Receptacle) pin 4</b> | Chassis ground | There should be continuity. |
| <b>X-461 (Receptacle) pin 6 X-461 (Receptacle) pin 6</b> | Chassis ground | There should be continuity. |

A. If there is continuity on all of the checks, then leave connector **X-461 X-461** disconnected and continue with step 5.

B. If there is no continuity for one or more of the checks, then locate and restore the faulty ground connection to the ECU. Repair or replace the harness as required.

5. Determine the condition of the ECU CAN circuit.

With the key switch in the OFF position, use a multimeter to measure the resistance of the CAN connection on the vehicle harness side :

| From   | To   | Value                           |
|--|--|---------------------------------|
| <b>X-461 (Receptacle) pin 24 X-461 (Receptacle) pin 24</b> | <b>X-461 (Receptacle) pin 25 X-461 (Receptacle) pin 25</b> | There should be <b>120 Ω</b> .  |
| <b>X-461 (Receptacle) pin 24 X-461 (Receptacle) pin 24</b> | Chassis ground   | There should not be continuity. |
| <b>X-461 (Receptacle) pin 25 X-461 (Receptacle) pin 25</b> | Chassis ground   | There should not be continuity. |

Use a multimeter to measure the resistance of the CAN termination resistor, internal to the ECU :

| From   | To   | Value                          |
|--|--|--------------------------------|
| <b>X-461 (Receptacle) pin 24 X-461 (Receptacle) pin 24</b> | <b>X-461 (Receptacle) pin 25 X-461 (Receptacle) pin 25</b> | There should be <b>120 Ω</b> . |

A. If the measured resistances are correct and neither conductor is grounded, then check the ECU for the appropriate software and re-flash, if necessary.

B. If the measured resistances are not correct or one or both of the conductors is grounded, then restore the termination resistance to the CAN circuit or replace the ECU.

6. Visually inspect the relevant harnesses and connectors for damage, bent or dislocated pins, corroded terminals, or broken wires. Verify that the connectors are fully installed. Flex the harnesses involved to reveal intermittent breaks or shorts in the wiring concerned. Operate the machine while you monitor the display.

A. If you find damage or the display indicates other than normal display readings, then repair the damage discovered during the inspection or locate and repair the other than normal display condition and verify that the error has been resolved.

B. If you do not find damage and the display indicates only normal readings, then erase the fault code and continue operation.

**Wiring harnesses - Electrical schematic sheet 05 SH05 - ENGINE CONTROL (55.100.DP-C.20.E.05)**

**Wiring harnesses - Electrical schematic sheet 29 SH29 - CAN BUS/DIAGNOSTIC (55.100.DP-C.20.E.29)**

**Wiring harnesses - Electrical schematic sheet 13 SH13 - INSTRUMENT CLUSTER (55.100.DP-C.20.E.13)**

**Wiring harnesses - Electrical schematic sheet 34 SH34 - TELEMATICS (55.100.DP-C.20.E.34)**

**Wiring harnesses - Electrical schematic sheet 05 SH05 - ENGINE CONTROL (55.100.DP-C.20.E.05)**

**Wiring harnesses - Electrical schematic sheet 26 SH26 - CAN BUS/DIAGNOSTIC (55.100.DP-C.20.E.26)**

**Wiring harnesses - Electrical schematic sheet 13 SH13 - INSTRUMENT CLUSTER (55.100.DP-C.20.E.13)**

**Wiring harnesses - Electrical schematic sheet 27 SH27 - TELEMATICS (55.100.DP-C.20.E.27)**

---

## 3526-Downstream NOx sensor internal failure (Short Circuit Error)

**NOTE:** Because this fault causes inducement, it is necessary to perform the SCR Fault Repair Verification Test once the fault has been resolved. Refer to the engine service manual **Selective Catalytic Reduction (SCR) exhaust treatment - Service instruction - SCR fault repair verification test (10.500)** if necessary.

**NOTE:** Because this fault causes inducement, it is necessary to perform the Engine Restart Counter Reset / Unlock Inducement configuration with the Electronic Service Tool (EST) before you return the machine to service. Refer to the engine service manual **Selective Catalytic Reduction (SCR) exhaust treatment - Configure - Engine restart counter reset (10.500)**, if necessary.

### Context:

For information regarding the functional operation of the smart Selective Catalytic Reduction (SCR) downstream NO<sub>x</sub> sensor, refer to the engine service manual **Nitrogen Oxide (NOx) sensor - Dynamic description (55.988)**. The SCR downstream NO<sub>x</sub> sensor has internal monitoring for an open wire or a short circuit and sends an error status in case of a detected failure. This fault code is the result of a short circuit error in the sensor NO<sub>x</sub> and/or oxygen level circuit.

### Cause:

The SCR downstream NO<sub>x</sub> sensor has reported, via the CAN bus to the ECU, that a short circuit exists in the NO<sub>x</sub> and/or oxygen level circuit.

### Possible failure modes:

1. A faulty SCR downstream NO<sub>x</sub> sensor.
2. A faulty ECU.

### Solution:

1. Verify that the fault is present and active.

Use the Electronic Service Tool (EST) to check the status of this fault.

A. If the fault is present and active, then continue with step 2.

B. If the fault is no longer present or in an inactive state, then the fault may be intermittent and not currently active. Continue with step 3.

2. As there is no method for field testing or re-flashing the sensor controller, replace the SCR downstream NO<sub>x</sub> sensor.

Then use the EST, refer to the engine service manual **Nitrogen Oxide (NOx) sensor - Configure - Reset ECU data (Downstream sensor) (55.988)**, if necessary, to perform the Replacement of Nox Downstream Sensor - Reset ECU Data configuration.

Then use the EST, refer to the engine service manual **Selective Catalytic Reduction (SCR) exhaust treatment - Configure - Engine restart counter reset (10.500)**, if necessary, to perform the Engine Restart Counter Reset / Unlock Inducement configuration.

Then perform the SCR Fault Verification Test, refer to the engine service manual **Selective Catalytic Reduction (SCR) exhaust treatment - Service instruction - SCR fault repair verification test (10.500)**, if necessary.

Then check to see that this fault is resolved.

A. If this fault is resolved, then return the machine to service.

B. If this fault is not resolved, then check the ECU for the appropriate software and re-flash, if necessary.

3. Visually inspect the relevant harnesses and connectors for damage, bent or dislocated pins, corroded terminals, or broken wires. Verify that the connectors are fully installed. Flex the harnesses involved to reveal intermittent breaks or shorts in the wiring concerned. Operate the machine while you monitor the display.

A. If you find damage or the display indicates other than normal display readings, then repair the damage discovered during the inspection or locate and repair the other than normal display condition and verify that the error has been resolved.

## **3756-ECU internal failure - Post injection quality**

### **Context:**

Engine performance is assisted by the addition of pilot injections, main injections and three post injections. The Engine Control Unit (ECU) monitors the start angle and efficiency of post Injection 2. If the ECU determines that the post Injection 2 is not within a plausible value, a calibration error has occurred and this fault will occur.

### **Solution:**

1. Check the ECU for the appropriate software and re-flash, if necessary.
  - A. If the fault has been resolved, return the machine to service.
  - B. If the fault has not been resolved, escalate an ASIST concern.

## 3961-CAN communication failure - External torque/speed checksum and counter

### Context:

The Engine Control Unit (ECU) is capable of connecting to and communicating on two separate Controller Area Networks (CAN). Proper configuration and monitoring of the two twisted pair configured networks is also a function of the ECU. The ECU monitors the throttle speed control function via CAN. If an error is detected during this monitoring, this fault will occur.

### Cause:

ECU has sensed an error during throttle speed control monitoring.

### Possible failure modes:

1. A vehicle system related CAN fault code.
2. A problem with the battery supply to the ECU.
3. A problem with the ground connection to the ECU.
4. An open circuit or a short circuit in the CAN circuit wiring.
5. A faulty ECU.

### Solution:

1. Verify that the fault is present and in an active state.

Use the Electronic Service Tool (EST) to check the status of this fault.

A. If the fault is present and active, then continue with step 2.

B. If the fault is no longer present or is in an inactive state, then the fault may be intermittent and not currently active. Continue with step 6.

2. Check for other vehicle CAN faults.

Use the EST to determine if vehicle CAN faults exist.

A. If other vehicle CAN faults exist, resolve the vehicle CAN faults, then check to see that this fault is also resolved.

B. If other vehicle CAN faults do not exist, then continue with step 3.

3. Check the ECU supply voltage.

Disconnect the vehicle harness from the ECU at connector **X-461 X-461**.

To energize the main relay, place a jumper wire between the vehicle harness side of connector **X-461 (Receptacle) pin 28 X-461 (Receptacle) pin 28** and chassis ground.

Use a multimeter to check for voltage on the vehicle harness side :

| From   | To             | Value                           |
|--|----------------|---------------------------------|
| <b>X-461 (Receptacle) pin 1 X-461 (Receptacle) pin 1</b> | Chassis ground | There should be <b>12.0 V</b> . |
| <b>X-461 (Receptacle) pin 3 X-461 (Receptacle) pin 3</b> | Chassis ground | There should be <b>12.0 V</b> . |
| <b>X-461 (Receptacle) pin 5 X-461 (Receptacle) pin 5</b> | Chassis ground | There should be <b>12.0 V</b> . |

A. If the voltage is present on all of the checks, then leave connector **X-461 X-461** disconnected and continue with step 4.

B. If the voltage is not present for one or more of the checks, then there is a problem with the battery supply to the ECU. Locate and restore supply power to the ECU. Repair or replace the harness as required.

## 4016-First and third shift modulation solenoid input (pin 13) feedback circuit is reading current without command

|  |  |
|--|--|
| 580N FOUR-WHEEL DRIVE (4WD) TIER 4B (FINAL) [NGC730186 - ]     | Transmission - Powershift transmission |
| 580N TWO-WHEEL DRIVE (2WD) TIER 4B (FINAL) [NGC730186 - ]      | Transmission - Powershift transmission |
| 580SN FOUR-WHEEL DRIVE (4WD) TIER 4B (FINAL) [NGC732639 - ]    | Transmission - Powershift transmission |
| 580SN TWO-WHEEL DRIVE (2WD) TIER 4B (FINAL) [NGC732639 - ]     | Transmission - Powershift transmission |
| 580SN WT FOUR-WHEEL DRIVE (4WD) TIER 4B (FINAL) [NGC735098 - ] | Transmission - Powershift transmission |
| 590SN FOUR-WHEEL DRIVE (4WD) TIER 4B (FINAL) [NGC736228 - ]    | Transmission - Powershift transmission |
| 590SN TWO-WHEEL DRIVE (2WD) TIER 4B (FINAL) [NGC736228 - ]     | Transmission - Powershift transmission |

### Context:

The first and third shift modulation solenoid input (pin 13) feedback circuit is reading too much current with command. The machine will shift into neutral while this fault is active.

### Cause:

The first and third shift modulation solenoid input (pin 13) feedback circuit is reading too much current with command.

### Possible failure modes:

1. Faulty wiring or connectors.
2. A short circuit in the 1/3 solenoid.
3. The 1/3 solenoid return wire, (X-300 pin 13) is shorted to another voltage source.
4. Faulty Trax control module.

### Solution:

1. Verify that the fault code is active.

Connect the Electronic Service Tool to the service tool connector.

To check for fault codes: Start and operate the machine.

A. Fault code **4016 - First and third shift modulation solenoid input (pin 13) feedback circuit is reading current without command** is not recorded again. Go to step 5.

B. Fault code **4016 - First and third shift modulation solenoid input (pin 13) feedback circuit is reading current without command** is recorded again. Go to step 2.

2. Verify that the wiring and connectors are free of damage.

Inspect the Trax control module connector **X-300** and the 1/3 solenoid connections. All connections should be secure and tight and free of corrosion, abrasion, and damage.

Inspect the harness from the Trax control module to the 1/3 solenoid. Verify that the harness is free of damage, corrosion, abrasion, and incorrect attachment.

A. The connectors are secure and the harness is free of damage. Go to step 3.

B. The connectors or the harness is damaged. Repair or replace the harness or the connectors as required. Return to step 1 to confirm elimination of fault.

3. Measure the voltage on the solenoid return wire.

Turn the ignition switch OFF.

Disconnect the Trax control module connector **X-300** and the 1/3 solenoid connector **X-382**.

Turn the ignition switch ON.

Measure the voltage from **X-300 (Receptacle) pin 13** to chassis ground. The voltage should be less than **0.5 V**. Wiggle the harness during measurement to reveal an intermittent condition.

## 4034-Shifter Lever malfunction: transmission in forward receives neutral and forward together

|  |  |
|--|--|
| 580N FOUR-WHEEL DRIVE (4WD) TIER 4B (FINAL) [NGC730186 - ]     | Transmission - Powershift transmission |
| 580N TWO-WHEEL DRIVE (2WD) TIER 4B (FINAL) [NGC730186 - ]      | Transmission - Powershift transmission |
| 580SN FOUR-WHEEL DRIVE (4WD) TIER 4B (FINAL) [NGC732639 - ]    | Transmission - Powershift transmission |
| 580SN TWO-WHEEL DRIVE (2WD) TIER 4B (FINAL) [NGC732639 - ]     | Transmission - Powershift transmission |
| 580SN WT FOUR-WHEEL DRIVE (4WD) TIER 4B (FINAL) [NGC735098 - ] | Transmission - Powershift transmission |
| 590SN FOUR-WHEEL DRIVE (4WD) TIER 4B (FINAL) [NGC736228 - ]    | Transmission - Powershift transmission |
| 590SN TWO-WHEEL DRIVE (2WD) TIER 4B (FINAL) [NGC736228 - ]     | Transmission - Powershift transmission |

### Context:

There is a malfunction in the shift lever. The transmission is in the forward position and receives a forward signal and a neutral signal together. This fault has occurred for a period greater than **5 s**.

### Cause:

There is a malfunction in the shift lever. The transmission is in the forward position and receives a forward signal and a neutral signal together. This fault has occurred for a period greater than **5 s**. The Trax control module will log the fault code and keep the transmission in the neutral position while the fault is active.

### Possible failure modes:

1. Faulty wiring or connectors from the FNR shift lever to the Trax control module.
2. A faulty FNR shift lever.
3. A faulty Trax control module.

### Solution:

1. Verify that the fault code is active.

Connect the Electronic Service Tool to the service tool connector.

To check for fault codes: Start and operate the machine.

A. The fault code is not recorded again. OK to return the machine to service.

B. Fault code 4034 is recorded again. Go to step **2**.

2. Verify that the wiring and the connectors are free of damage.

Inspect the Trax control module connector X-300 and the FNR shift lever connections. All connections should be secure and free of corrosion, abrasion, and damage.

Inspect the harness from the Trax control module to the FNR shift lever. Verify that the harness is free of damage, corrosion, abrasion, and incorrect attachment.

A. The connectors are secure and the harness is free of damage. Go to step **3**.

B. The connectors or the harness has damage. Repair or replace the harness or the connectors as required. Return to step **1** to confirm elimination of fault.

3. Measure the voltage at the FNR shift lever.

Use backprobes or a breakout harness (as shown below) to measure the voltage at the FNR switch.

**Wiring harnesses - Electrical schematic sheet 24 SH24 - TRAX SPS/PS CONTROLLER (55.100.DP-C.20.E.24)**

## 4210-3RD/4TH gear shift rail position reporting forth gear at startup

|  |  |
|--|--|
| 580N FOUR-WHEEL DRIVE (4WD) TIER 4B (FINAL) [NGC730186 - ]     | Transmission - Powershift transmission |
| 580N TWO-WHEEL DRIVE (2WD) TIER 4B (FINAL) [NGC730186 - ]      | Transmission - Powershift transmission |
| 580SN FOUR-WHEEL DRIVE (4WD) TIER 4B (FINAL) [NGC732639 - ]    | Transmission - Powershift transmission |
| 580SN TWO-WHEEL DRIVE (2WD) TIER 4B (FINAL) [NGC732639 - ]     | Transmission - Powershift transmission |
| 580SN WT FOUR-WHEEL DRIVE (4WD) TIER 4B (FINAL) [NGC735098 - ] | Transmission - Powershift transmission |
| 590SN FOUR-WHEEL DRIVE (4WD) TIER 4B (FINAL) [NGC736228 - ]    | Transmission - Powershift transmission |
| 590SN TWO-WHEEL DRIVE (2WD) TIER 4B (FINAL) [NGC736228 - ]     | Transmission - Powershift transmission |

### Context:

The shift rails should be in neutral when the unit first starts, all of the gear position switches should be closed. This fault code indicate that the Trax control module monitored the transmission was in gear at startup, when it should be in the neutral position.

### Cause:

The Trax control module monitored the transmission was in gear at startup, when it should be in the neutral position.

### Possible failure modes:

1. Verify that the gear position switch giving the fault is open. If the switch reads closed, then check for a harness/resistor network issue.
2. If the switches and harness are functioning correctly, then the shift rail is out of position at start-up.

### Solution:

1. Verify that the fault code is active.

Connect the Electronic Service Tool to the service tool connector.

To check for fault codes: Start and operate the machine.

- A. Fault code **4210 - 3RD/4TH gear shift rail position reporting forth gear at startup** is not recorded again. Go to step **4**.
  - B. Fault code **4210 - 3RD/4TH gear shift rail position reporting forth gear at startup** is recorded again. Go to step **2**.
2. Verify that the wiring and the connectors are free of damage.

Inspect the Trax control module connector **X-300** and the gear switch connections. All connections should be secure, tight, free of corrosion, abrasion, and damage.

Inspect the harness from the Trax control module to the gear switches. Verify that the harness is free of damage, corrosion, abrasion, and incorrect attachment.

- A. The connectors are secure and the harness is free of damage. Go to step **3**.
  - B. The connectors or the harness has damage. Repair or replace the harness or the connectors as required. Return to step **1** to confirm the elimination of the fault.
3. Refer to:
    - Powershift transmission external controls - Overview S-type transmission (21.135)**
    - Powershift transmission external controls - Service instruction Shift rail position testing - S-type transmission (21.135)**
    - Powershift transmission external controls - Service instruction Shift rail position physical measurement - S-type transmission (21.135).**
  4. Visually inspect the relevant harnesses and connectors for damage, bent or dislocated pins, corroded terminals, or broken wires.

Verify that the connectors are fully installed.

Flex the harnesses involved to reveal an intermittent break or a short circuit in the wiring.

## 9011-A/D fault foot throttle, internal error

**Context:**

An internal problem within the instrument cluster.

**Cause:**

An internal problem within the instrument cluster.

**Possible failure modes:**

1. A faulty instrument cluster.

**Solution:**

1. Verify that the fault code is active.

Connect the Electronic Service Tool to the service tool connector.

To check for fault codes: Start and operate the machine.

A. The fault is not recorded again. OK to return the machine to service.

B. Fault code **9011 - A/D fault foot throttle, internal error** is recorded again. Go to step 2.

2. Replace the instrument cluster.

A. Return to step 1 to confirm the elimination of the fault.

## 17349-Short circuit to battery error for Low Voltage System

### Context:

The Engine Control Unit (ECU) requests operation of the glow plug control module via a Pulse Width Modulated (PWM) control circuit and monitors the status of possible electrical defects via a diagnostic feedback signal from the glow plug control module. If the ECU is notified of a short to a voltage source condition in one or more of the glow plug circuits, this fault will occur. For information regarding the functional operation of the glow plug control module, refer to the engine service manual **Glow plug system Glow plug control module - Overview - Glow plug control module (55.202)**.

### Cause:

The glow plug control module has communicated to the ECU, via a diagnostic connection, that a short circuit to a voltage source condition exists in one or more of the glow plug circuits.

### Possible failure modes:

1. Faulty glow plug control circuit wiring, shorted to a voltage source.
2. Faulty ECU, software.

### Solution:

1. Verify that the fault is present and active.

Use the Electronic Service Tool (EST) to check the status of this fault.

- A. If the fault is present and active, continue with step **2**.
- B. If the fault is no longer present or is in an inactive state, then the fault may be intermittent and not currently active. Continue with step **5**.

2. Check each of the glow plug circuits for a short circuit to another voltage source.

Disconnect the vehicle harness from the glow plug control module at connector **X-469 X-469**.

Disconnect the engine harness from each of the glow plugs.

With the key switch in the ON position, use a multimeter to check for voltage on the engine harness side :

| From                        | To             | Result                      |
|-----------------------------|----------------|-----------------------------|
| Glow plug 1 connector pin 1 | Chassis ground | There should be no voltage. |
| Glow plug 2 connector pin 1 | Chassis ground | There should be no voltage. |
| Glow plug 3 connector pin 1 | Chassis ground | There should be no voltage. |
| Glow plug 4 connector pin 1 | Chassis ground | There should be no voltage. |

- A. If there is voltage measured on any of the checks, then leave all of the connectors disconnected and continue with step **3**.

- B. If there is no voltage measured on any of the checks, then continue with step **4**.

3. Locate the short circuit to another voltage source.

Disconnect the vehicle harness from the engine interface connector **X-470 X-470**.

With the key switch in the ON position, use a multimeter to check for voltage on the vehicle harness side :

| From   | To             | Result                      |
|--|----------------|-----------------------------|
| <b>X-470 (Receptacle) pin 61 X-470 (Receptacle) pin 61</b> | Chassis ground | There should be no voltage. |
| <b>X-470 (Receptacle) pin 60 X-470 (Receptacle) pin 60</b> | Chassis ground | There should be no voltage. |
| <b>X-470 (Receptacle) pin 58 X-470 (Receptacle) pin 58</b> | Chassis ground | There should be no voltage. |

## 17416-DEF/AdBlue Supply module supply voltage control relay short circuit to battery

### Context:

The Engine Control Unit (ECU) controls the Selective Catalytic Reduction (SCR) relay with a low side driver control circuit. If the ECU detects a short circuit to battery in the low side driver circuit, then this fault will occur.

### Cause:

The ECU has detected a short circuit to battery condition in the SCR low side driver control circuit.

### Possible failure modes:

1. An internal failure in the SCR relay.
2. A short circuit in the SCR relay wiring.
3. A faulty ECU.

### Solution:

1. Verify that the fault is present and active.

Use the Electronic Service Tool (EST) to check the status of this fault.

A. If the fault is present and active, then continue with step 2.

B. If the fault is no longer present or is in an inactive state, then the fault may be intermittent and not currently active. Continue with step 4.

2. Check the SCR relay coil for an internal failure.

Remove the SCR relay.

Use a multimeter to measure the relay coil resistance on the SCR relay pins :

| From             | To               | Value   |
|------------------|------------------|---|
| SCR relay pin 85 | SCR relay pin 86 | There should be approximately <b>70 - 130 Ω</b> . |

A. If there is approximately **70 - 130 Ω**, then leave the SCR relay disconnected and continue to step 3.

B. If there is not approximately **70 - 130 Ω**, then the relay has failed. Replace the SCR relay and retest.

3. Check the SCR relay vehicle harness wiring for a short circuit to battery.

Disconnect the vehicle harness from the ECU at connector **X-462 X-462**.

With the key in the ON position, use a multimeter to check for voltage on the vehicle harness side :

| From                       | To             | Value                       |
|----------------------------|----------------|-----------------------------|
| SCR relay connector pin 85 | Chassis ground | There should be no voltage. |

With the key in the OFF position, use a multimeter to check for continuity on the vehicle harness side :

| From   | To  | Value                          |
|--|---|--------------------------------|
| <b>X-462 (Receptacle) pin 20 X-462 (Receptacle) pin 20</b> | To all other pins in connector <b>X-462 X-462</b> | There should be no continuity. |

A. If there is voltage or continuity to another pin, then there is a short circuit in the wiring in the vehicle harness. Locate and repair the damaged conductors. Repair or replace the harness as required.

B. If there is no voltage or continuity, then check the ECU for the appropriate software and re-flash, if necessary.

4. Visually inspect the relevant harnesses and connectors for damage, bent or dislocated pins, corroded terminals, or broken wires. Verify that the connectors are fully installed. Flex the harnesses involved to reveal intermittent breaks or shorts in the wiring concerned. Operate the machine while you monitor the display.
  - A. If you find damage or the display indicates other than normal display readings, then repair the damage discovered during the inspection or locate and repair the other than normal display condition and verify that the error has been resolved.
  - B. If you do not find damage and the display indicates only normal readings, then erase the fault code and continue operation.

**Wiring harnesses - Electrical schematic sheet 31 SH31 - ADDITIONAL ECU CIRCUITS (55.100.DP-C.20.E.31)**

**Wiring harnesses - Electrical schematic sheet 33 SH33 - PRE-START (55.100.DP-C.20.E.33)**

**Wiring harnesses - Electrical schematic sheet 31 SH31 - ADDITIONAL ECU CIRCUITS (55.100.DP-C.20.E.31)**

**Wiring harnesses - Electrical schematic sheet 33 SH33 - PRE-START (55.100.DP-C.20.E.33)**

## **17504-Signal fault of the temperature sensor located in the Urea Quality sensor (reported via CAN Frame ComRx\_CRI1)**

### **Context:**

For information regarding the functional operation of the DEF/AdBlue® urea quality sensor, refer to the engine service manual **Diesel Exhaust Fluid (DEF)/AdBlue® quality sensor - Overview (55.988)**. The DEF/AdBlue® urea quality sensor has internal monitoring for operating conditions and reports status along with sensed data to the Engine Control Unit (ECU). If an internal sensor system error is detected, this fault will occur.

### **Cause:**

The DEF/AdBlue® urea quality sensor has reported to the ECU that it has an internal sensor system error.

### **Possible failure modes:**

1. Faulty DEF/AdBlue® urea quality sensor hardware or firmware.
2. Faulty ECU, software.

### **Solution:**

1. As there is no method for field testing, replace the DEF/AdBlue® urea quality sensor.

Then check to see that the fault is resolved.

- A. If the fault is resolved, return the machine to service.
- B. If the fault is not resolved, check the ECU for the appropriate software and re-flash, if necessary.

- A. If you find damage or the display indicates other than normal display readings, then repair the damage discovered during the inspection or locate and repair the other than normal display condition and verify that the error has been resolved.
- B. If you do not find damage and the display indicates only normal readings, then erase the fault code and continue operation.

## 19105-DEF/AdBlue tank heater ECU driver over temperature failure

### Context:

The Engine Control Unit (ECU) monitors the DEF/Adblue® tank heating valve circuit. If the ECU detects a short circuit another voltage source in the DEF/Adblue® tank heating valve control circuit, then this fault will occur.

### Cause:

The ECU has detected a short circuit to another voltage source in the DEF/Adblue® tank heating valve circuit.

### Possible failure modes:

1. A faulty DEF/Adblue® tank heating valve.
2. The DEF/Adblue® tank heating valve low side driver control circuit wiring is shorted to another voltage source.
3. A faulty ECU.

### Solution:

1. Verify that the fault is present and active.

Use the Electronic Service Tool (EST) to check the status of this fault.

A. If the fault is present and active, then continue with step 2.

B. If the fault is no longer present or in an inactive state, then the fault may be intermittent and not currently active. Continue with step 5.

2. Check the DEF/Adblue® tank heating valve for an internal failure.

Disconnect the DEF/Adblue® tank heating valve at connector **X-611 X-611**

Use a multimeter to perform the following resistance check on the DEF/Adblue® tank heating valve pins :

| From                     | To                       | Value                                      |
|--------------------------|--------------------------|--|
| <b>X-611 X-611</b> pin 1 | <b>X-611 X-611</b> pin 3 | There should be between <b>11 - 16 Ω</b> . |

A. If the value is within the specified range, then leave connector **X-611 X-611** disconnected and continue to step 3.

B. If the value is not within the specified range, then the DEF/Adblue® tank heating valve has failed internally. Replace the DEF/Adblue® tank heating valve and retest.

3. Check the DEF/Adblue® tank heating valve for a short to key battery power condition.

With the key in the ON position, use a multimeter to perform the following voltage check :

| From                     | To             | Value                       |
|--------------------------|----------------|-----------------------------|
| <b>X-611 X-611</b> pin 3 | Chassis ground | There should be no voltage. |

A. If there is voltage, then there is a short circuit to switched battery power in the DEF/Adblue® tank heating valve wiring. Locate and repair the shorted conductors. Repair or replace the harness as required.

B. If there is no voltage, then continue to step 4.

4. Check the DEF/Adblue® tank heating valve for a short circuit to another voltage source.

Disconnect connector the ECU connector **X-462 X-462**.

With the key in the OFF position, use a multimeter to perform the following continuity check :

| From   | To                                       | Value                          |
|--|--|--------------------------------|
| <b>X-462 (Receptacle) pin 7 X-462 (Receptacle) pin 7</b> | All pins in connector <b>X-462 X-462</b> | There should be no continuity. |

---

## 19356-Downstream NO<sub>x</sub> sensor signal and NH<sub>3</sub> sensor signal plausibility check failure

### Context:

For information regarding the functional operation of the NH<sub>3</sub> sensor and the NH<sub>3</sub> control unit, refer to the engine service manual **Ammonia (NH<sub>3</sub>) sensor - Dynamic description (55.988)**. The NH<sub>3</sub> control unit is required to report information at regular intervals to the Engine Control Unit (ECU) via Controller Area Network (CAN). The NH<sub>3</sub> sensor senses both NH<sub>3</sub> and NO<sub>x</sub>. If the NO<sub>x</sub> signal is smaller than the NH<sub>3</sub> signal, this fault will occur.

### Cause:

The NH<sub>3</sub> control unit has reported via CAN to the ECU that the NO<sub>x</sub> and/or NH<sub>3</sub> signal is not plausible.

### Possible failure modes:

1. A faulty NH<sub>3</sub> sensor.
2. The NH<sub>3</sub> sensor signal has drifted.
3. A faulty NH<sub>3</sub> control unit.
4. A faulty ECU.

### Solution:

1. Verify that the fault is present and active.

Use the Electronic Service Tool (EST) to check the status of this fault.

A. If the fault is present and active, then continue with step 2.

B. If the fault is no longer present or in an inactive state, then the fault may be intermittent and not currently active. Continue with step 4.

2. As there is no method for field testing the temperature sensing portion of the sensor, replace the NH<sub>3</sub> sensor.

Then check to see that the fault is resolved.

A. If the fault is resolved, return the machine to service.

B. If the fault is not resolved, continue with step 3.

3. As there is no method of field testing or re-flashing the NH<sub>3</sub> control unit, replace the NH<sub>3</sub> control unit.

Then check to see that the fault is resolved.

A. If the fault is resolved, return the machine to service.

B. If the fault is not resolved, check the ECU for the appropriate software and re-flash, if necessary.

4. Visually inspect the relevant harnesses and connectors for damage, bent or dislocated pins, corroded terminals, or broken wires. Verify that the connectors are fully installed. Flex the harnesses involved to reveal intermittent breaks or shorts in the wiring concerned. Operate the machine while you monitor the display.

A. If you find damage or the display indicates other than normal display readings, then repair the damage discovered during the inspection or locate and repair the other than normal display condition and verify that the error has been resolved.

B. If you do not find damage and the display indicates only normal readings, then erase the fault code and continue operation.

## 19859-SRC low for turbine upstream temperature sensor

### Context:

The Engine Control Unit (ECU) monitors the exhaust manifold temperature sensor. If the ECU detects a voltage less than **0.45 V** in the exhaust manifold temperature sensor signal circuit, then this fault will occur. The sensor value will be frozen at the last valid value for a preliminary failure or jump to a fixed replacement value of **350 °C (662 °F)** if the failure is validated.

### Cause:

The ECU has detected a voltage less than **0.45 V** in the exhaust manifold temperature sensor signal circuit. For more information regarding the technical specifications of the exhaust manifold temperature sensor, refer to the engine service manual **Exhaust manifold temperature sensor - Technical Data (55.014)**.

### Possible failure modes:

1. A short circuit to ground in the exhaust manifold temperature sensor wiring.
2. An external failure in the exhaust manifold temperature sensor.
3. A faulty ECU.

### Solution:

1. Verify that the fault is present and active.

Use the Electronic Service Tool (EST) to check the status of this fault.

A. If the fault is present and active, then continue with step 2.

B. If the fault is no longer present or in an inactive state, then the fault may be intermittent and not currently active. Continue with step 5.

2. Check the exhaust manifold temperature sensor for an internal failure.

Disconnect the engine harness from the exhaust manifold temperature sensor.

Use a multimeter to measure the resistance on the exhaust manifold temperature sensor pins :

| From                                      | To  | Value  |
|---|---|--|
| Exhaust manifold temperature sensor pin 1 | Exhaust manifold temperature sensor pin 2 | There should be between <b>170.2 - 849.7 Ω</b> . |

A. If there is between **170.2 - 849.7 Ω**, then leave the exhaust manifold temperature sensor disconnected. Continue to step 3.

B. If there is not between **170.2 - 849.7 Ω**, then the exhaust manifold temperature sensor has failed. Replace the exhaust manifold temperature sensor and retest.

3. Check the exhaust manifold temperature sensor engine harness wiring.

Disconnect the vehicle harness from the engine interface connector **X-470 X-470**.

With the key in the OFF position, use a multimeter to perform the following continuity check on the engine harness side :

| From   | To   | Value                          |
|--|--|--------------------------------|
| <b>X-470 (Receptacle) pin 26 X-470 (Receptacle) pin 26</b> | <b>X-470 (Receptacle) pin 25 X-470 (Receptacle) pin 25</b> | There should be no continuity. |
| <b>X-470 (Receptacle) pin 26 X-470 (Receptacle) pin 26</b> | All pins in connector <b>X-470 X-470</b>                   | There should be no continuity. |

A. If there is continuity , there is a short circuit in the exhaust manifold temperature sensor signal circuit in the engine harness wiring. Locate and repair the shorted conductor. Repair or replace the harness as required.

4. Remove the caps from the hydraulic lines. Reconnect the hydraulic lines.

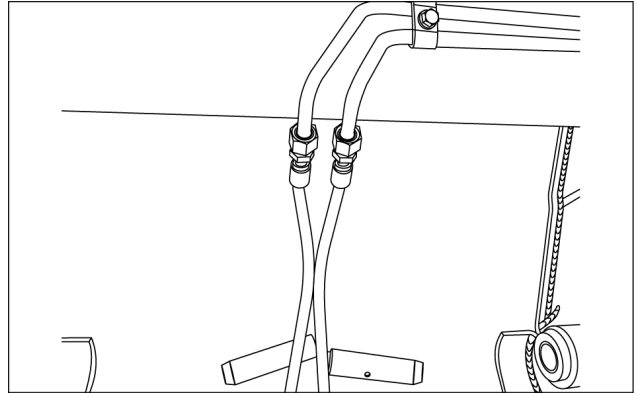

RCPH11TLB151AAM 6

## **Bucket - Replace Tooth point**

1. Use a hammer and a punch to remove the flex pin from the tooth point.
2. Install a new tooth point and drive a new flex pin into the tooth point. Install the flex pin so that the shoulders are toward the cutting edge.

## Dipper - Exploded view Dipper and bucket

580SN FOUR-WHEEL DRIVE (4WD) TIER 4B (FINAL) [NGC732639 - ]

580SN TWO-WHEEL DRIVE (2WD) TIER 4B (FINAL) [NGC732639 - ]

580SN WT FOUR-WHEEL DRIVE (4WD) TIER 4B (FINAL) [NGC735098 - ]

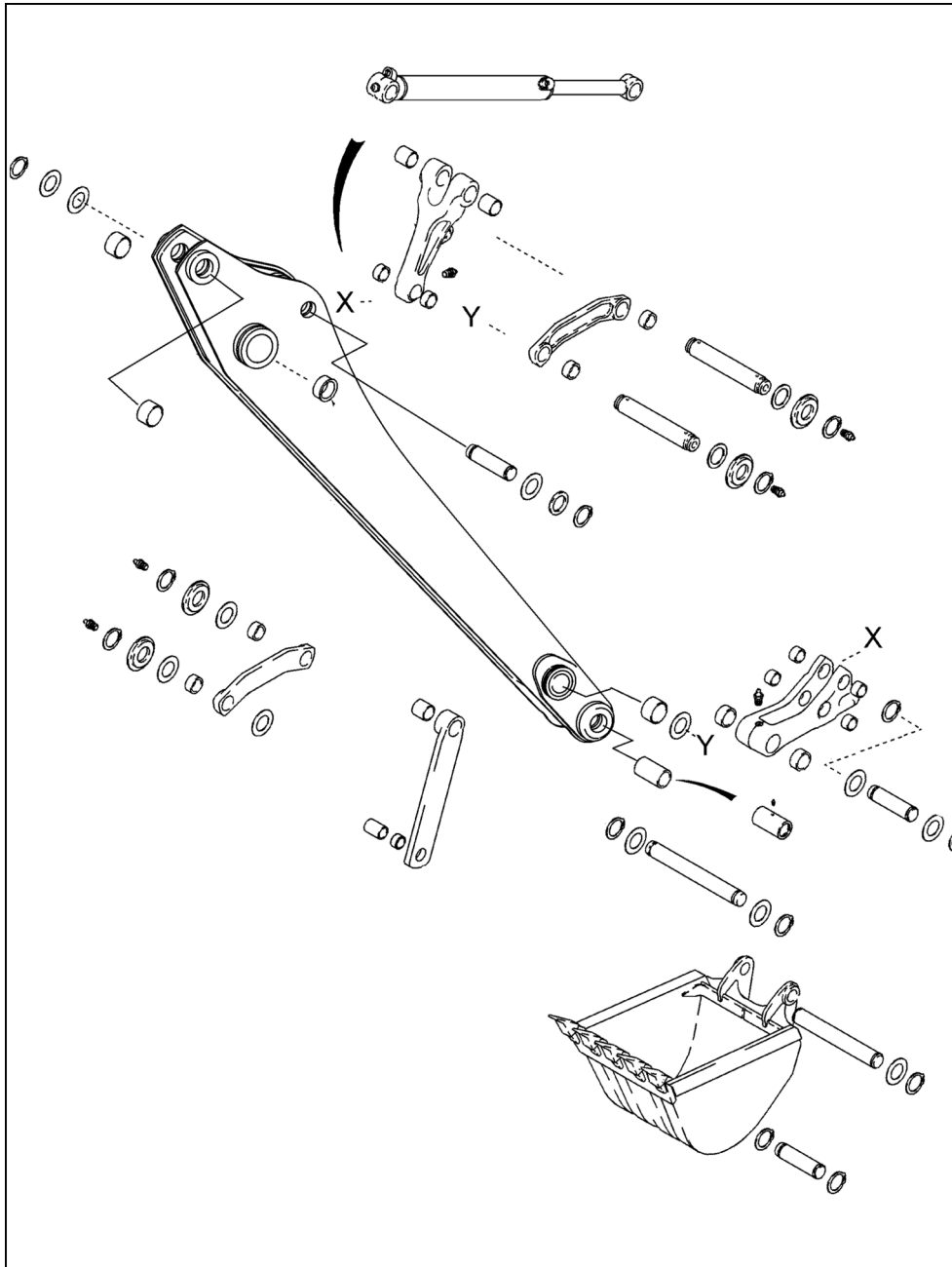

RCPH10TLB118GAL 1

# Contents

---

## Platform, cab, bodywork, and decals - 90

### Pneumatically-adjusted operator seat - 124

#### FUNCTIONAL DATA

|                                      |   |
|--------------------------------------|---|
| Pneumatically-adjusted operator seat |   |
| Exploded view .....                  | 3 |
| Seat pneumatic lift system           |   |
| Exploded view .....                  | 5 |

#### SERVICE

|  |    |
|--|----|
| Pneumatically-adjusted operator seat         |    |
| Replace Pivot safety switch .....            | 7  |
| Disassemble Pedestal seat .....              | 9  |
| Inspect Pedestal seat .....                  | 14 |
| Assemble Pedestal seat .....                 | 16 |
| Disassemble Mechanical suspension seat ..... | 21 |
| Inspect Mechanical suspension seat .....     | 34 |
| Assemble Mechanical suspension seat .....    | 37 |
| Disassemble Air suspension seat .....        | 50 |
| Inspect Air suspension seat .....            | 67 |
| Assemble Air suspension seat .....           | 68 |

CLICK HERE TO **DOWNLOAD** THE COMPLETE MANUAL

- Thank you very much for reading the preview of the manual.
- You can download the complete manual from: [www.heydownloads.com](http://www.heydownloads.com) by clicking the link below



- Please note: If there is no response to CLICKING the link, please download this PDF first and then click on it.

CLICK HERE TO **DOWNLOAD** THE COMPLETE MANUAL