

# 521D Loader Service Manual 6-40745 Table of Contents

Description	Section No.	Form No.
<b>General</b>		
	<b>Tab 1</b>	
Section Index - General		6-42730
Standard Torque Specifications	1001	8-71603
Fluids and Lubricants	1002	6-40762
Metric Conversion Chart	1003	7-52950
Loctite Product Chart		8-98902
<b>Engines</b>		
	<b>Tab 2</b>	
Section Index - Engines		6-42281
Engine and Radiator Removal and Installation	2000	6-42290
Engine and Radiator Removal and Installation P.I.N. JEE0135501 and Above	2000	6-48920
Stall Tests	2002	6-40771
For Engine Repair, See the Engine Service Manual		6-74500
<b>Fuel System</b>		
	<b>Tab 3</b>	
Section Index - Fuel System		6-42300
For Fuel System Repair, See the Engine Service Manual		6-74500
<b>Electrical</b>		
	<b>Tab 4</b>	
Section Index - Electrical		6-42311
Removal and Installation of Starter and Alternator	4001	6-42321
Electrical Specifications and Troubleshooting	4002	6-40782
Electrical Specifications and Troubleshooting P.I.N. JEE0135501 and Above	4002	6-48930
Batteries	4003	6-42330
Information and Diagnostic Center	4005	6-42352
Alternator - 65 Ampere	4007	7-12260
Alternator - 45 Ampere	4008	6-42360

CLICK HERE TO **DOWNLOAD** THE COMPLETE MANUAL

- Thank you very much for reading the preview of the manual.
- You can download the complete manual from: [www.heydownloads.com](http://www.heydownloads.com) by clicking the link below



- Please note: If there is no response to CLICKING the link, please download this PDF first and then click on it.

CLICK HERE TO **DOWNLOAD** THE COMPLETE MANUAL

## TORQUE SPECIFICATIONS - STEEL HYDRAULIC FITTINGS

Nom. SAE Dash Size	Tube OD	Thread Size	Pound-Inches	Newton metres	Thread Size	Pound-Inches	Newton metres
<b>O-ring Face Seal End</b>					<b>O-ring Boss End Fitting or Lock Nut</b>		
-4	1/4 inch 6.4 mm	9/16-18	120 to 144	14 to 16	7/16-20	204 to 240	23 to 27
-6	3/8 inch 9.5 mm	11/16-16	216 to 240	24 to 27	9/16-18	300 to 360	34 to 41
-8	1/2 inch 12.7 mm	13/16-16	384 to 480	43 to 54	3/4-16	540 to 600	61 to 68
					Thread Size	Pound-Feet	Newton metres
-10	5/8 inch 15.9 mm	1-14	552 to 672	62 to 76	7/8-14	60 to 65	81 to 88
Nom. SAE Dash Size	Tube OD	Thread Size	Pound-Feet	Newton metres	1-1/16-12	85 to 90	115 to 122
					1-3/16-12	95 to 100	129 to 136
-12	3/4 inch 19.0 mm	1-3/16-12	65 to 80	90 to 110	1-5/16-12	115 to 125	156 to 169
-14	7/8 inch 22.2 mm	1-3/16-12	65 to 80	90 to 110	1-5/8-12	150 to 160	203 to 217
-16	1.0 inch 25.4 mm	1-7/16-12	92 to 105	125 to 140	1-7/8-12	190 to 200	258 to 271
-20	1-1/4 inch 31.8 mm	1-11/16-12	125 to 140	170 to 190			
-24	1-1/2 inch 38.1 mm	2-12	150 to 180	200 to 254			

## TABLE OF CONTENTS

CONVERSION FACTORS .....	3
Metric to U.S. ....	3
U.S. to Metric .....	4

### STEP 8

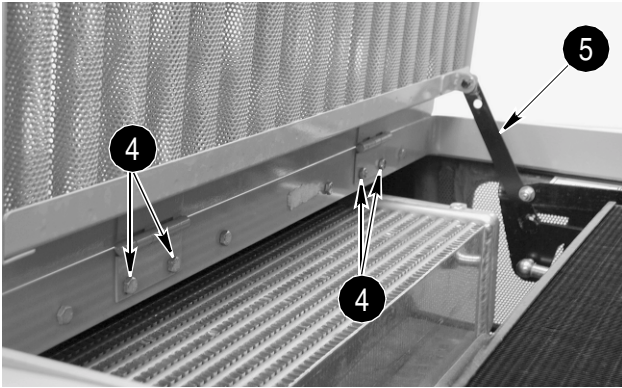

BD01D144

Remove four bolts (4) securing hinges of screen to hood. Disconnect prop bar (5) from screen and remove screen.

### STEP 9

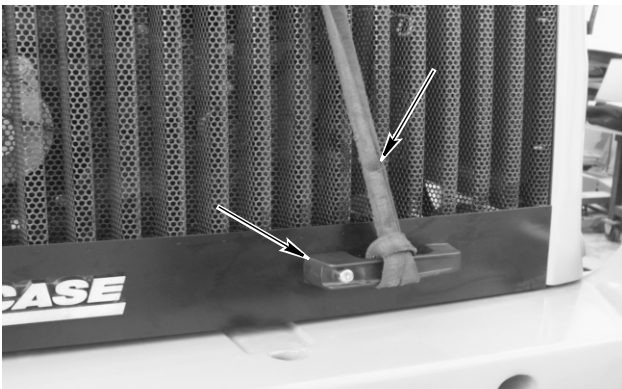

BD01D255

Connect a lifting strap to the hood handle and connect lifting equipment to strap. Depress handle latch and let hood raise.

### STEP 10



BD01D256

Take up all slack in strap connected to hood handle.

### STEP 11

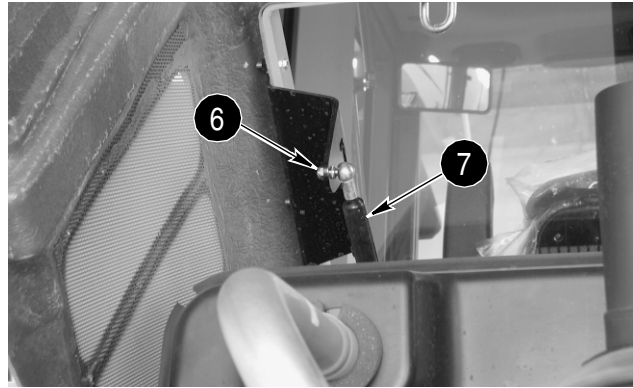

BD01D145

Remove lock nut (6) securing LH spring (7) to hood. Repeat to remove lock nut securing RH spring to hood. Disconnect springs from hood; it may be necessary to raise hood to disconnect springs from hood.

### STEP 12



BD01D258

At front RH side of hood, identify, tag, and disconnect hood wiring harness connector from rear chassis wiring harness connector.

### STEP 13

Lower hood.

### STEP 63

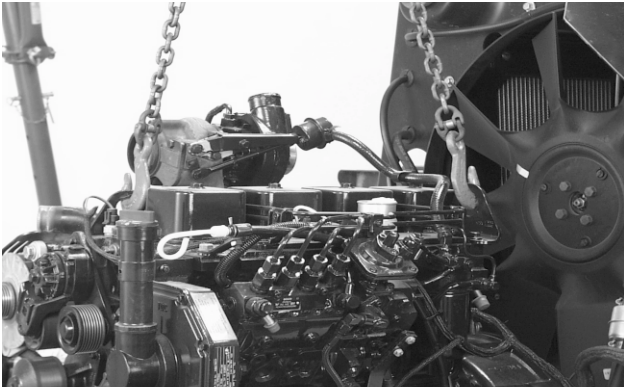

BD01D220

Connect lifting equipment to engine lifting brackets. Take up all slack in lifting equipment.

### STEP 64



BD01D206

At front of engine, remove nut, bolt, and two washers securing both sides of engine to rear chassis.

### STEP 65

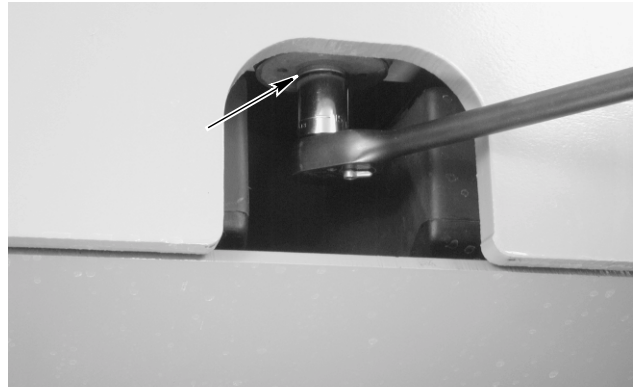

BD01D181

At rear of rear chassis, between fuel tank mounting plate and rear chassis, remove bolt and washer securing rear of engine to rear chassis.

### STEP 66

Slowly raise engine from rear chassis. Be sure all harness connections and hoses have been disconnected and out of the way. Remove engine from machine.

### STEP 113

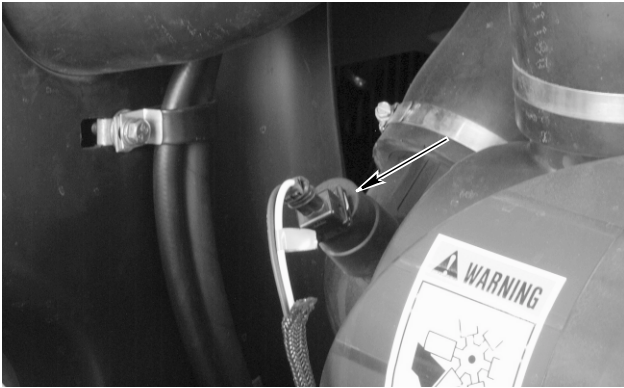

BD01D150

Connect engine wiring harness connector to air filter restriction switch following tag installed during removal. Remove and discard tag.

### STEP 114

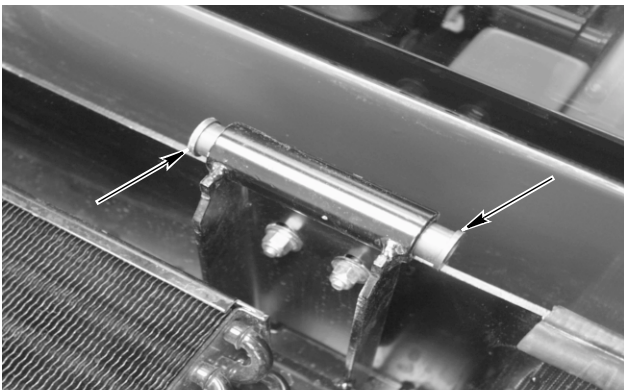

BD01D242

If removed, install bushings at hood pivot points on top of cooling frame.

### STEP 115



BD01D254

Raise and move hood into position above loader. Slowly and carefully lower hood into position while guiding hood pivot points into position with pivot points on top of cooling frame.

### STEP 116

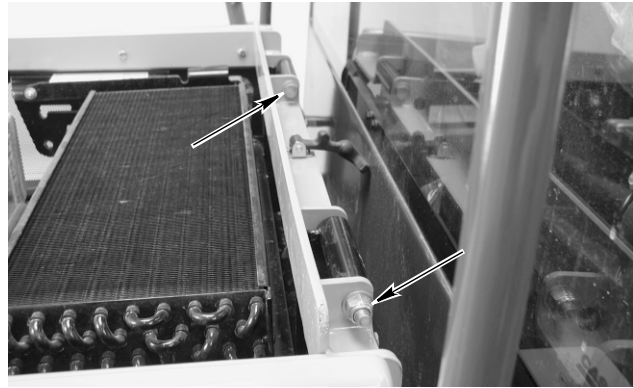

BD01D147

Install two bolts, four washers, and two nuts to secure hood. Tighten bolts to a torque of 36 to 44 Nm (26.5 to 32.5 lb-ft).

### STEP 117



BD01D254

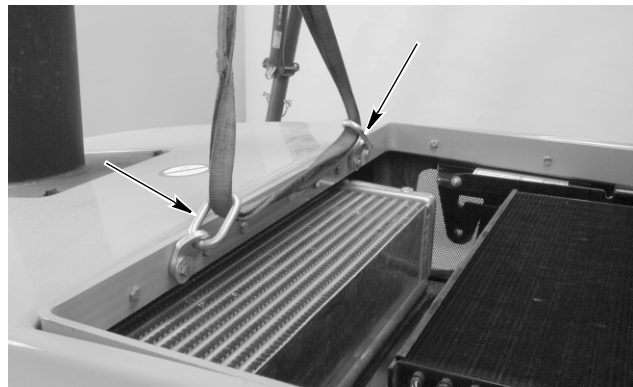

BD01D149

Lower lifting equipment until strap connected to two lifting eyes can be removed. Remove the two lifting eyes from hood.

## TABLE OF CONTENTS

ENGINE .....	3
Removal .....	3
Installation .....	17
RADIATOR .....	31
Removal .....	31
Installation .....	33

## SPECIFICATIONS

Cooling System Capacity .....	34.1 Liters (9 Gallons)
Engine Oil	
Capacity with Filter Change .....	10.5 Liters (11 Quarts)
Type of Oil .....	Case No. 1 Engine Oil (SAE 15W-40)
Hydraulic Reservoir	
Refill Capacity with Filter Change .....	68.5 Liters (18 Gallons)
Type of Oil .....	MS-1209 Hy-Tran Ultra®

## SPECIAL TORQUES

Engine Mounting Bolts .....	244 to 298 Nm (180 to 220 lb-ft)
Engine Drive Shaft Mounting Bolts .....	53 to 62 Nm (39 to 46 lb-ft)
Radiator Hose Clamps .....	10.1 to 11.3 Nm (90 to 100 lb-inch)
Counterweight Mounting Bolts .....	955 to 1075 Nm (704 to 793 lb-ft)
Charge Air Tube Hose Clamps .....	10.1 to 11.3 Nm (90 to 100 lb-inch)
Muffler Front Mounting Bracket to Engine Mounting Bolts .....	118 to 133 Nm (87 to 98 lb-ft)
Muffler Rear Mounting Bracket to Engine Mounting Bolts .....	68 to 77 Nm (50 to 56.5 lb-ft)
Muffler Mounting Brackets to Muffler Mounting Bolts .....	39 to 44 Nm (29 to 32 lb-ft)
Turbocharger Elbow Clamp at Muffler .....	20 to 25 Nm (15 to 18 lb-ft)
Turbocharger Elbow Clamp at Turbocharger .....	4.8 to 5.2 Nm (42.5 to 46 lb-inch)
Air Cleaner Hose Clamps at Turbocharger .....	10.1 to 11.3 Nm (90 to 100 lb-inch)
Air Cleaner Inlet and Outlet Hose Clamps .....	3.6 to 4.5 Nm (32.9 to 39.6 lb-inch)
Hood Mounting Bolts at Cooling Frame Pivot Points .....	36 to 44 Nm (26.5 to 32.5 lb-ft)
Screen Hinge Mounting Bolts .....	27 to 33 Nm (19.8 to 24.4 lb-ft)
Coupler to Flywheel Mounting Bolts .....	53 to 62 Nm (39 to 46 lb-ft)
Air Conditioning Compressor Mounting Bracket Mounting Bolts	
M8 Bolt .....	34 to 44 Nm (25 to 32.5 lb-ft)
M10 Bolt .....	67 to 87 Nm (49.4 to 64 lb-ft)

**STEP 60**

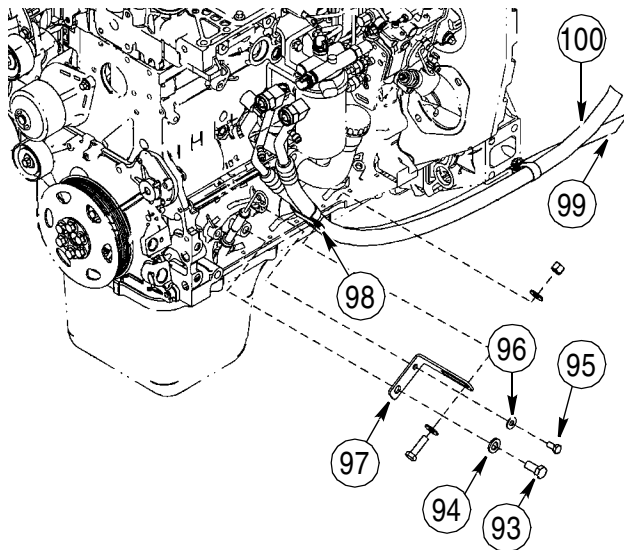

BS02J066

- |            |             |
|------------|-------------|
| 93. BOLT   | 97. BRACKET |
| 94. WASHER | 98. CLAMP   |
| 95. BOLT   | 99. HOSE    |
| 96. WASHER | 100. HOSE   |

Remove two bolts (93 and 95) and washers (94 and 96) securing bracket (97). Let bracket (97) with clamp (98) and hoses (99 and 100) hang down from air conditioning compressor.

**STEP 61**

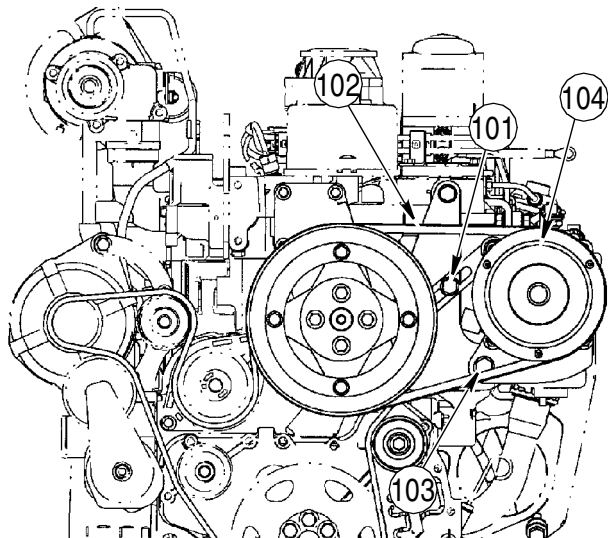

BS02J067

- |                 |                    |
|-----------------|--------------------|
| 101. BOLT       | 103. BOLT          |
| 102. DRIVE BELT | 104. AC COMPRESSOR |

Loosen bolts (101 and 103). Move air conditioning compressor (104) to put slack in drive belt (102) then remove drive belt. Remove bolt (101), washers, spacer, and nut.

**STEP 62**

Install battery covers on RH side. Support air conditioning compressor (104) and remove bolt (103), three washers, and nut securing compressor. Remove compressor and place on RH battery cover.

**STEP 63**

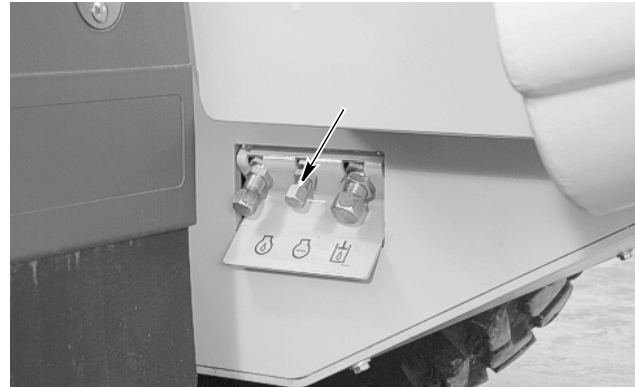

BD00M031

Put a 37.8 liter (10 gallon) container below radiator drain. Remove cap and drain coolant into container. Install cap after coolant has drained.

**STEP 64**

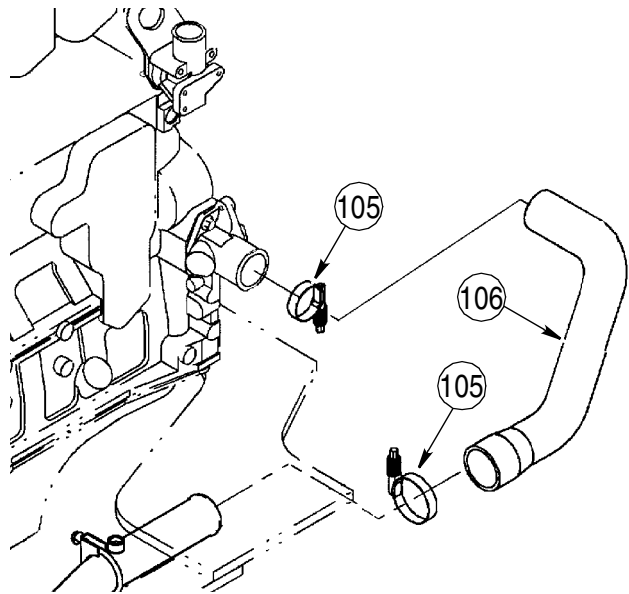

BS02J069

- |            |
|------------|
| 105. CLAMP |
| 106. HOSE  |

Loosen two clamps (105). Disconnect and remove bottom hose (106).

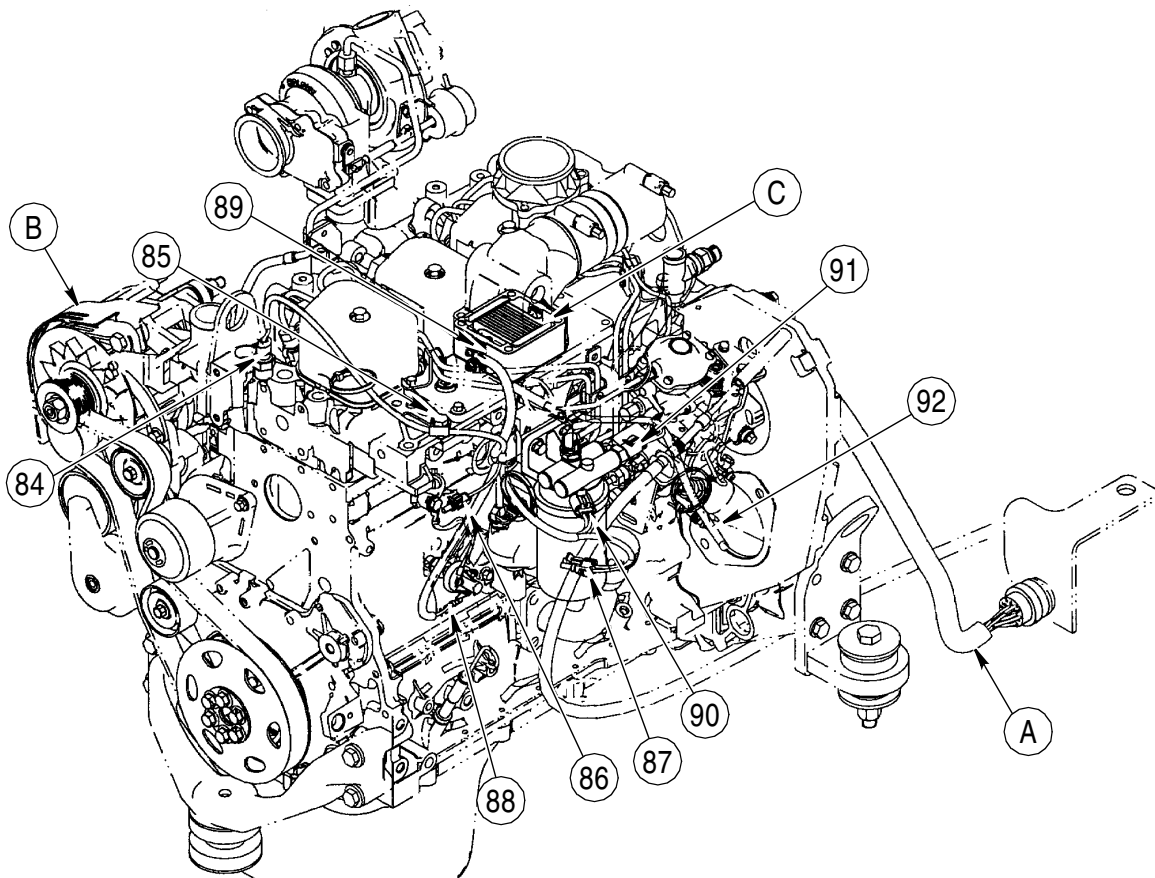

BS02J060

- |               |               |               |                   |
|---------------|---------------|---------------|-------------------|
| 84. CONNECTOR | 87. CONNECTOR | 90. CONNECTOR | A. ENGINE HARNESS |
| 85. BOLT      | 88. WIRE      | 91. CONNECTOR | B. ALTERNATOR     |
| 86. CONNECTOR | 89. WIRE      | 92. WIRE      | C. GRID HEATER    |

**STEP 110**

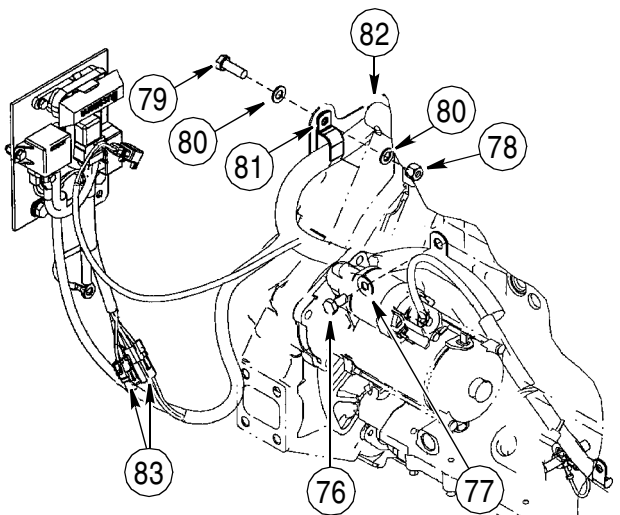

BS02J058

- |            |                            |
|------------|----------------------------|
| 76. BOLT   | 80. WASHER                 |
| 77. WASHER | 81. CLAMP                  |
| 78. NUT    | 82. FLYWHEEL HOUSING COVER |
| 79. BOLT   | 83. CONNECTOR              |

Connect four connectors (83) following tags installed during removal. Remove and discard tags.

**STEP 111**

Position clamp (81) holding engine harness and rear chassis harness on flywheel housing cover (82). Bottom harness is engine harness; top harness is rear chassis harness. Install nut (78) and bolt (79) and two washers (80) to secure clamp. Repeat this step to install remaining clamp (81) on other side of flywheel housing cover (82).

**STEP 112**

Route engine harness and rear chassis harness to rear of engine.

**STEP 113**

Position clamps of engine and rear chassis harnesses on engine block. Top harness is rear chassis harness; bottom harness is engine harness. Install bolt (76) and washer (77) to secure clamps.

### STEP 170

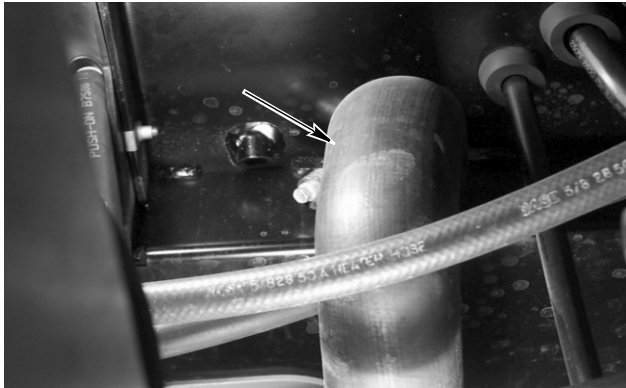

BD01D229

Loosen two clamps securing radiator bottom hose. Remove bottom hose.

### STEP 171

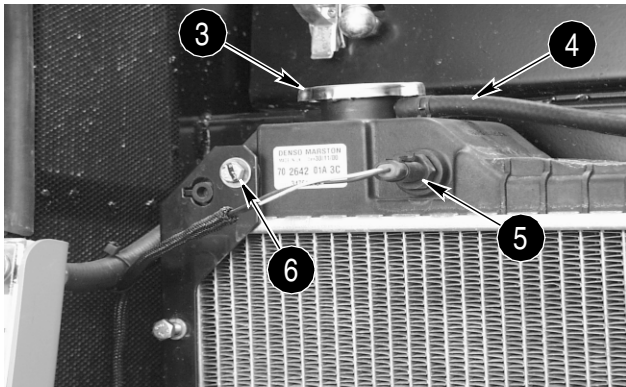

BD01D223

- 3. RADIATOR CAP
- 4. OVERFLOW HOSE
- 5. COOLANT LEVEL SENDER
- 6. SCREW

Remove radiator cap (3) and disconnect overflow hose (4) from radiator. Install radiator cap. Disconnect connector from coolant level sender (5). Remove screw (6) and install lifting eye.

### STEP 172

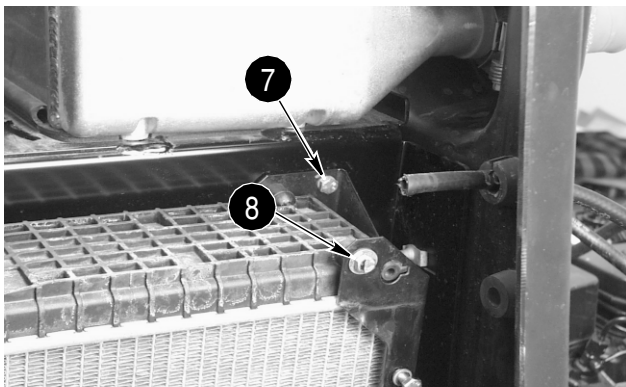

BD01D226

- 7. BOLTS
- 8. SCREW

Remove two bolts (7) and lock washers on sides of radiator. Remove screw (8) and install lifting eye.

### STEP 173



BD01D227

Connect lifting equipment to lifting eyes. Take up all slack in lifting equipment.

### STEP 174

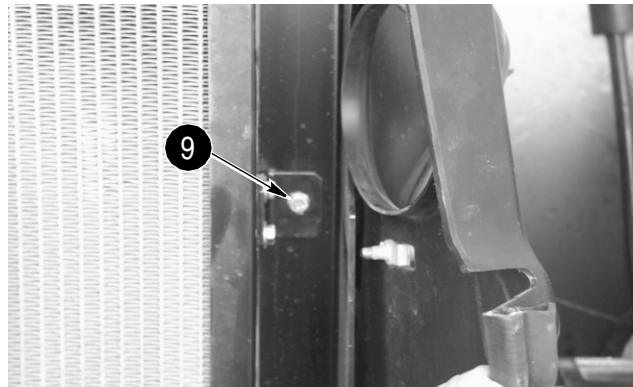

BD01D225

- 9. BOLT

Remove four bolts (9) and lock washers securing radiator to cooling frame. Carefully and slowly raise radiator from cooling frame and remove from loader.

# Section 4001

## REMOVAL AND INSTALLATION OF STARTER AND ALTERNATOR

CASE CORPORATION  
700 State Street  
Racine, WI 53404 U.S.A.

CASE CANADA CORPORATION  
3350 South Service Road  
Burlington, ON L7N 3M6 CANADA

Bur 6-42321

Copyright © 2003 Case Corporation  
Printed in U.S.A.  
August, 2001 (Revised February, 2003)

# Section 4002

4002

## ELECTRICAL SPECIFICATIONS AND TROUBLESHOOTING

**CASE CORPORATION**  
700 State Street  
Racine, WI 53404 U.S.A.

**CASE CANADA CORPORATION**  
3350 South Service Road  
Burlington, ON L7N 3M6 CANADA

Bur 6-40782

Copyright © 2002 Case Corporation  
Printed in U.S.A.  
March, 2001 (Revised June, 2002)

Wire Identification Codes

21C Bk - 1.0

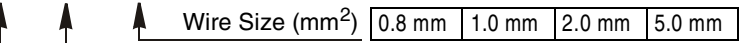

Wire Color		Bk = Black	DU = Dark Blue	S = Gray	LG = Light Green	K = Pink
Wire Name		T = Tan	W = White	N = Brown	G = Green	U = Blue
		LU = Light Blue	Or = Orange	R = Red	P = Purple	Y = Yellow

Wire Identification			From Connector		To Connector	
Wire	Circuit	Color, Size, and Material	Connector	Cavity	Connector	Cavity
0_DAU	Analog Ground	Bk-0.8-SXL	22F Cab Transmission	30	13F Cab-Pedestal	8
0_DAV	Diag TECM Grnd	Bk-0.8-SXL	108F Diagnostic Connector	3	221F Ground Cab	1
0_DAW	Ground	Bk-1.0-SXL	42F Beacon Sw	7	118F Back-up Alarm Dis Sw	7
0_DAX	Beacon Wiper Diode Grnd	Bk-0.8-SXL	206F Cab Floor Weld Stud	1	140M Diode Module	C
0_DAY	Switch Grnd	Bk-1.0-SXL	210F Fan Reverser Sw	7	SPL_D13 Ground	1
0_DB	Can Pilot Sol Grnd	Bk-0.8-SXL	89M Pilot Pres Sol	B	219F Ground Cab	1
0_DC	Relay Grnd	Bk-0.8-SXL	52F Ether Start Relay	85	49F Accessory Relay	85
0_DD	Ride Cntrl Relay Sink	Bk-0.8-SXL	19F TECM	57	50F Ride Control Relay	85
0_DE	Relay Grnd	Bk-0.8-SXL	48F Ignition Relay #2	85	47F Ignition Relay #1	85
0_DF	Relay Grnd	Bk-0.8-SXL	49F Accessory Relay	85	48F Ignition Relay #2	85
0_DG	Relay Grnd	Bk-0.8-SXL	52F Ether Start Relay	85	58F Volt Meter Relay	85
0_DH	Relay Grnd	Bk-0.8-SXL	58F Volt Meter Relay	85	54F Neutral Start Relay	85
0_DJ	Relay Grnd	Bk-0.8-SXL	54F Neutral Start Relay	85	222F Ground Cab	1
0_DK	AC Brk Lt Time Del Horn Grnd	Bk-0.8-SXL	203F Relay AC	85	204F Relay Brake Lights	85
0_DL	Signal Ground	Bk-0.8-SXL	22F Cab-Transmission	23	13F Cab-Pedestal	39
0_DM	Speed Sensor Grounds	Bk-0.8-SXL	19F TECM	3	22F Cab Transmission	11
0_DN	Out Speed Sensor Grnd	Bk-0.8-SXL	19F TECM	4	22F Cab Transmission	28
0_DP	Diag TECM Grnd	Bk-0.8-SXL	19F TECM	1	221F Ground Cab	1
0_DQ	Diag TECM Grnd	Bk-0.8-SXL	19F TECM	2	221F Ground Cab	1
0_DR	Dome Court Work Lt Grnd	Bk-1.0-SXL	24M Cab Roof	E	223F Ground Cab	1
0_DS	Dome Court Work Lt Grnd	Bk-1.0-SXL	24M Cab Roof	G	223F Ground Cab	1
0_DT	Dome Court Work Lt Grnd	Bk-1.0-SXL	23F Cab Roof	B	223F Ground Cab	1
0_DU	Beacon Wiper Diode Grnd	Bk-1.0-SXL	23F Cab Roof	C	206F Cab Floor Weld Stud	1
0_DV	Beacon Wiper Diode Grnd	Bk-0.8-SXL	206F Cab Floor Weld Stud	1	13F Cab-Pedestal	61
0_DW	Ground	Bk-0.8-SXL	45F Rear Wiper Sw	7	118F Back-up Alarm Dis Sw	7
0_DX	Horn Ground	Bk-0.8-SXL	13F Cab-Pedestal	41	220F Ground Cab	1
0_DY	Blwr Wiper Seat Grnd	Bk-1.0-SXL	28M Seat Comp Motor	B	218F Ground Cab	1
0_DZ	Blwr Wiper Seat Grnd	Bk-2.0-SXL	29M Blower Motor	4	218F Ground Cab	1
0_E	Fuel Redundant Br Cool Grnd	Bk-1.0-SXL	160 Engine Grounds	1	171 Fuel Sender Grnd	1
0_F	Frt Rear Wash Hot Grnd	Bk-1.0-SXL	162 Engine Ground	1	3 Rear Washer	2

Wire Identification Codes																					
<div style="display: flex; align-items: center; justify-content: space-between;"> <div style="text-align: left;"> <p><b>21C Bk - 1.0</b></p> <p>↑      ↑      ↑</p> <p>Wire Name      Wire Color      Wire Size (mm<sup>2</sup>)</p> </div> <div style="border: 1px solid black; padding: 2px;"> <table style="border-collapse: collapse;"> <tr> <td style="padding: 2px 10px;">0.8 mm</td> <td style="padding: 2px 10px;">1.0 mm</td> <td style="padding: 2px 10px;">2.0 mm</td> <td style="padding: 2px 10px;">5.0 mm</td> </tr> </table> </div> </div>							0.8 mm	1.0 mm	2.0 mm	5.0 mm											
0.8 mm	1.0 mm	2.0 mm	5.0 mm																		
<table border="1" style="width: 100%; border-collapse: collapse;"> <tr> <td style="width: 25%;">Bk = Black</td> <td style="width: 25%;">DU = Dark Blue</td> <td style="width: 25%;">S = Gray</td> <td style="width: 25%;">LG = Light Green</td> <td style="width: 25%;">K = Pink</td> </tr> <tr> <td>T = Tan</td> <td>W = White</td> <td>N = Brown</td> <td>G = Green</td> <td>U = Blue</td> </tr> <tr> <td>LU = Light Blue</td> <td>Or = Orange</td> <td>R = Red</td> <td>P = Purple</td> <td>Y = Yellow</td> </tr> </table>							Bk = Black	DU = Dark Blue	S = Gray	LG = Light Green	K = Pink	T = Tan	W = White	N = Brown	G = Green	U = Blue	LU = Light Blue	Or = Orange	R = Red	P = Purple	Y = Yellow
Bk = Black	DU = Dark Blue	S = Gray	LG = Light Green	K = Pink																	
T = Tan	W = White	N = Brown	G = Green	U = Blue																	
LU = Light Blue	Or = Orange	R = Red	P = Purple	Y = Yellow																	
Wire Identification			From Connector		To Connector																
Wire	Circuit	Color, Size, and Material	Connector	Cavity	Connector	Cavity															
25S	Output Sw Power VPS1	LU-0.8-TXL	22M Cab-Transmission	22	102 Trans Control	7															
25S_A	Output Sw Power VPS1	LU-0.8-SXL	22F Cab-Transmission	22	SPL_D12 Common Power	1															
25S_B	Output Sw Power VPS1	LU-0.8-SXL	19F TECM	12	SPL_D12 Common Power	1															
25S_C	Output Sw Power VPS1	LU-0.8-SXL	19F TECM	13	SPL_D12 Common Power	1															
25T_A	Neutral Signal	LU-0.8-SXL	92 Ether Switch	1	70 Transmission Shifter	D															
25T_B	Neutral Signal	LU-0.8-SXL	13M Pedestal-Cab	46	92 Ether Switch	1															
25T_C	Neutral Signal	LU-0.8-SXL	13F Cab-Pedestal	46	SPL_D18 Neutral Signal	1															
25T_D	Neutral Signal	LU-0.8-SXL	19F TECM	67	SPL_D18 Neutral Signal	1															
25T_E	Neutral Signal	LU-0.8-SXL	54F Neutral Start Relay	86	SPL_D18 Neutral Signal	1															
25W	3rd And 4th Gear Signal	LU-0.8-SXL	13M Pedestal-Cab	48	183 Transmission Shifter	B															
25W_A	3rd And 4th Gear Signal	LU-0.8-SXL	19F TECM	65	13F Cab-Pedestal	48															
25Y	Trans Kickdown Signal	LU-0.8-SXL	13M Pedestal-Cab	50	183 Transmission Shifter	D															
25Y_A	Trans Kickdown Signal	LU-0.8-SXL	13F Cab-Pedestal	50	SPL_D11 Trans Kick Down Signal	1															
25Y_B	Trans Kickdown Sig	LU-0.8-SXL	19F TECM	22	SPL_D11 Trans Kick Down Signal	1															
25Y_C	Trans Kickdown Signal	LU-0.8-SXL	20M Trans Kick-Down	2	SPL_D11 Trans Kick Down Signal	1															
25Z	1st And 4th Gear Signal	LU-0.8-SXL	13M Pedestal-Cab	49	183 Transmission Shifter	C															
25Z_A	1st And 4th Gear Signal	LU-0.8-SXL	19F TECM	63	13F Cab-Pedestal	49															
26E	Trans Enable Signal	LU-0.8-SXL	19F TECM	31	199F Trans Enable Sw	3															
26F_A	FNR Forward Signal	LU-0.8-SXL	198 FNR Switch	6	197M FNR-Main Cab	2															
26F_B	FNR Forward Signal	LU-0.8-SXL	19F TECM	20	197F Main Cab FNR	2															
26J	FNR Switch Jumper	LU-0.8-SXL	198 FNR Switch	2	198 FNR Switch	4															
26N_A	FNR Neutral Signal	LU-0.8-SXL	198 FNR Switch	3	197M FNR-Main Cab	3															
26N_B	FNR Neutral Signal	LU-0.8-SXL	19F TECM	44	197F Main Cab FNR	3															
26R_A	FNR Reverse Signal	LU-0.8-SXL	198 FNR Switch	1	197M FNR-Main Cab	4															
26R_B	FNR Reverse Signal	LU-0.8-SXL	19F TECM	30	197F Main Cab FNR	4															
28C	Ether Start Control	W-0.8-SXL	13M Pedestal-Cab	52	182 Ether Switch	1															
28C_A	Ether Start Control	W-0.8-SXL	52F Ether Start Relay	86	13F Cab-Pedestal	52															
28P	Ether Sol	W-1.0-SXL	103 Ether Sol Opt	A	21M Rear-Cab	1															
28P_A	Ether Sol	W-0.8-SXL	52F Ether Start Relay	87	21F Cab-Rear	1															
28T	Ether Start Temp Sw	W-1.0-SXL	97 Ether Temp Sw	A	65M Eng-Rear (Ether Start)	1															



# TROUBLESHOOTING IGNITION RELAY, ACCESSORY RELAY, VOLTMETER RELAY, AND TIME DELAY MODULE

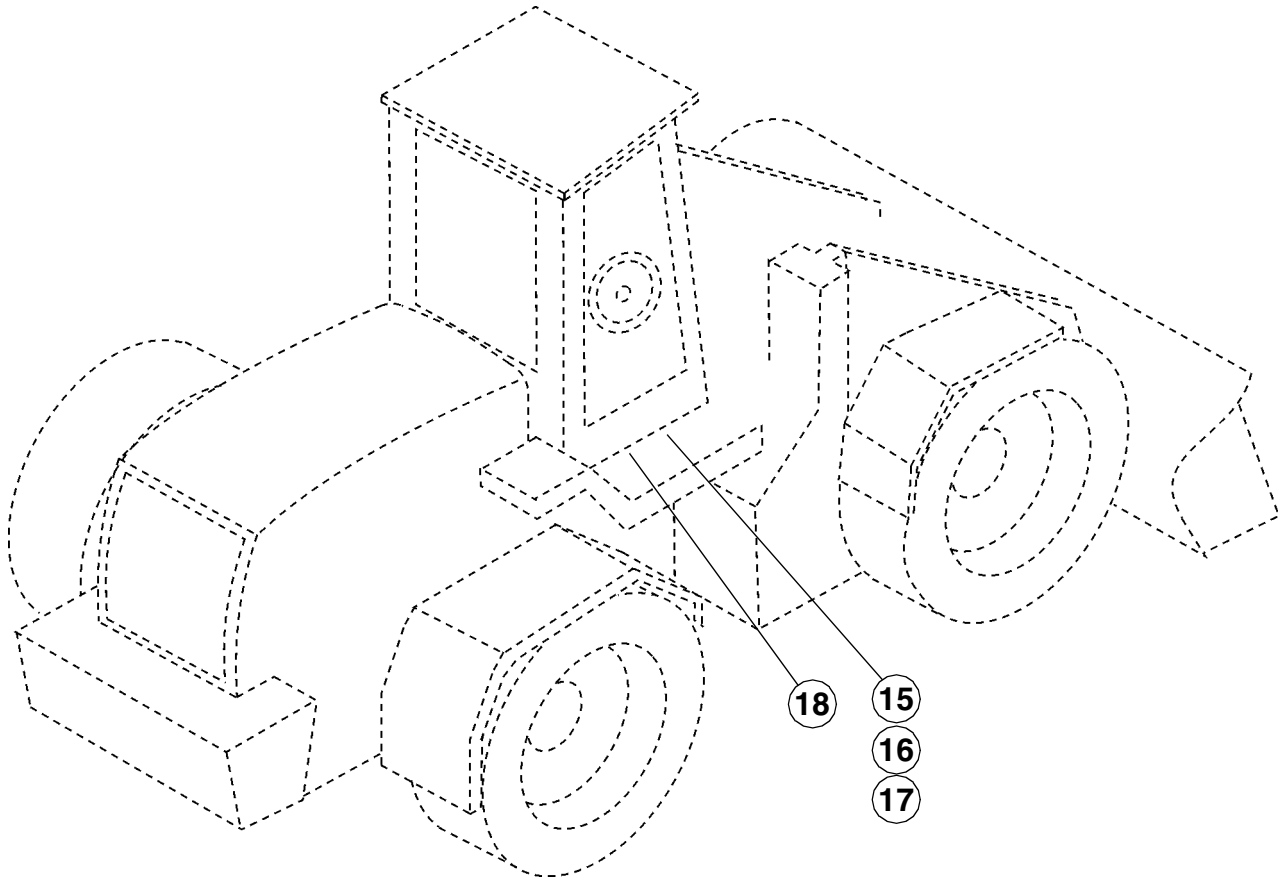

- 15. IGNITION RELAY NO. 2
- 17. VOLTMETER RELAY NO. 12
- 16. ACCESSORY RELAY NO. 3
- 18. TIME DELAY MODULE

BC00N140

<b>15 – Ignition Relay No. 2</b>		
Check Points	Reading	Possible Cause of Bad Reading
Terminal for wire 0 to ground	Continuity	Bad ground circuit.
<b>NOTE:</b> Put the master disconnect switch in the ON position. Turn the ignition switch to the ON position.		
Terminal for wire 1_T to ground	24 volts	Check circuit 1 to B+ stud.
Terminal for wire 13K to ground	24 volts	Check circuit 13K and ignition switch.
Terminal for wire 13R to ground	24 volts	Bad ignition relay No. 2 (15).

<b>47 – Instrument Cluster (Continued)</b>		
<b>NOTE:</b> Put the blower switch in any position other than OFF and thermostat switch fully clockwise.		
Connector terminal 10 to ground	24 volts	Check fuse G, blower switch, thermostat switch, and A/C low pressure switch. Also check circuits 61R, 61A, and 61T.
<b>NOTE:</b> Put the five position rotary lamp switch in position four or five.		
Connector terminal 12 to ground	24 volts	Check lamp switch and fuse A'. Also check circuits 18A and 42R.
<b>NOTE:</b> Put the rotating beacon switch in the ON position.		
Connector terminal 13 to ground	24 volts	Check rotating beacon switch and fuse X. Also check circuit 46.
<b>NOTE:</b> Put the five position rotary lamp switch in position four or five. Put the high/low beam switch in HIGH BEAM position.		
Connector terminal 15 to ground	24 volts	Check high/low beam switch, high/low beam relay, five position rotary lamp switch, and fuse C'. Also check circuits 18C and 64D and wires 41H and 41J_A.
<b>NOTE:</b> Put the turn signal switch in the LEFT TURN position.		
Connector terminal 16 to ground	24 volts on and off every 1-2 seconds	Check fuse B, turn signal switch, and flasher module. Also check wire 19B, circuit 45A to flasher module, and circuit 45L from flasher module to instrument cluster.
<b>NOTE:</b> Put the turn signal switch in the RIGHT TURN position.		
Connector terminal 17 to ground	24 volts on and off every 1-2 seconds	Check fuse B, turn signal switch, and flasher module. Also check wire 19B, circuit 45B to flasher module, and circuit 45R from flasher module to instrument cluster.
<b>NOTE:</b> Put the program/reset switch in the PROGRAM position.		
Connector terminal 24 to ground	24 volts	Bad program/reset switch. Also check wire 37P and wire 1A_B to ignition switch.
<b>NOTE:</b> Press and hold the program/reset switch in the RESET position.		
Connector terminal 25 to ground	24 volts	Bad program/reset switch. Also check wire 37R_B and wire 1A_B to ignition switch.
<b>NOTE:</b> Press and hold up/down count switch in UP position.		
Connector terminal 26 to ground	24 volts	Fuse S, or up/down count switch, or time delay module bad. Also check wires 37U and wire 13D from time delay module to fuse S, and circuit 19S.
<b>NOTE:</b> Press and hold up/down count switch in DOWN position.		
Connector terminal 27 to ground	24 volts	Fuse S, or up/down count switch, or time delay module bad. Also check wire 37D and wire 13D from time delay module to fuse S, and circuit 19S.

## TROUBLESHOOTING SECONDARY STEERING COMPONENTS AND RIDE CONTROL

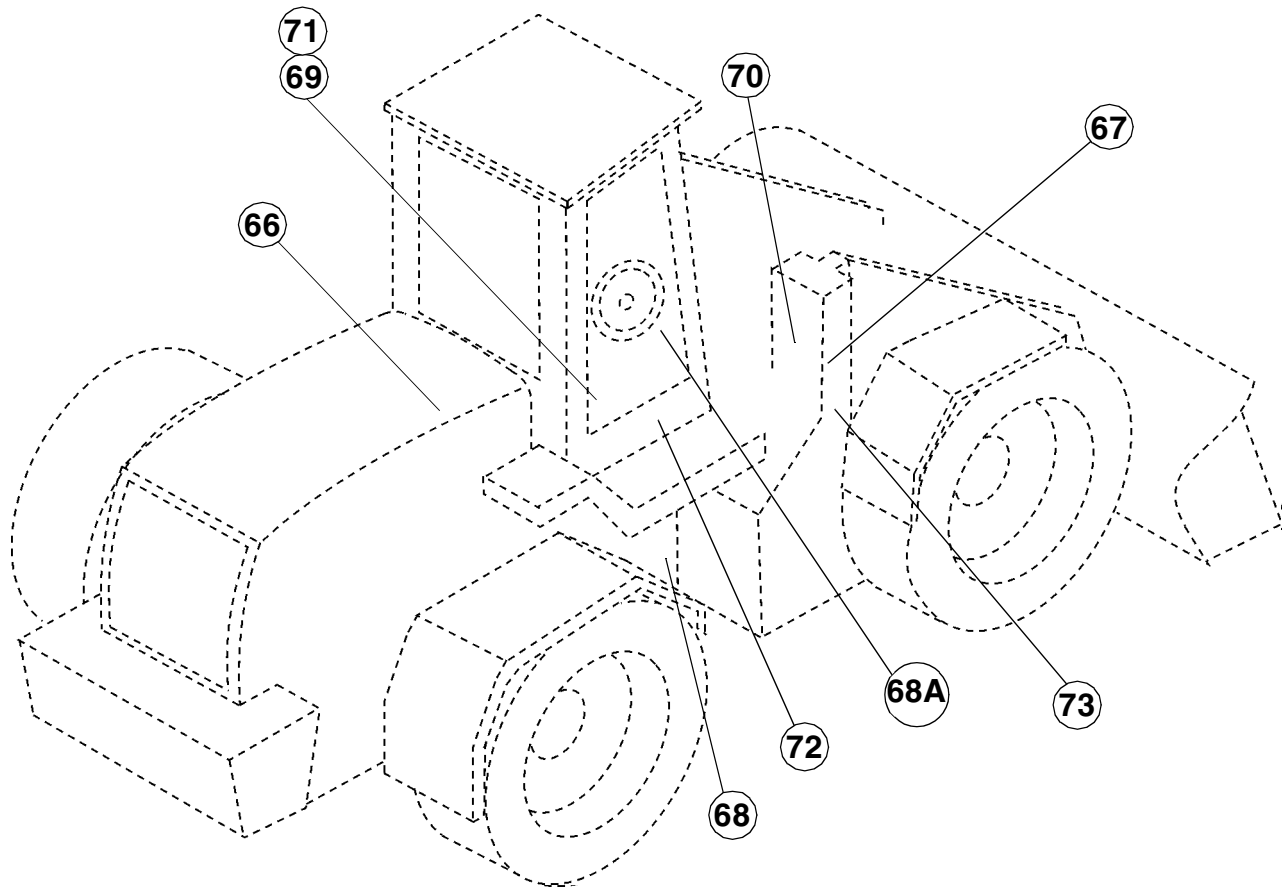

- 66. SECONDARY STEERING MODULE (OPTION)
- 67. SECONDARY STEERING PRESSURE SWITCH (OPTION)
- 68. SECONDARY STEERING MOTOR (OPTION)
- 68A. SECONDARY STEERING SOLENOID (OPTION)
- 69. PIN ENGAGE SWITCH (OPTION)

- 70. PIN ENGAGE SOLENOID (OPTION)
- 71. RIDE CONTROL SWITCH
- 72. RIDE CONTROL RELAY NO. 4
- 73. RIDE CONTROL SOLENOID

BC00N140

<b>81 – Horn</b>		
<b>Check Points</b>	<b>Reading</b>	<b>Possible Cause of Bad Reading</b>
Terminal for wire 0_AD to ground	Continuity	Bad ground circuit.
<b>NOTE:</b> <i>Disconnect the wire 64 from the horn (81). Have an assistant push and hold the horn switch.</i>		
Terminal for wire 64 to ground.	24 volts	Check the horn relay (80). Also check wires 64 and 64_A.
<b>NOTE:</b> <i>If the readings are good replace the horn (81).</i>		

<b>82 – Seat Compressor and Switch (Option)</b>		
<b>Check Points</b>	<b>Reading</b>	<b>Possible Cause of Bad Reading</b>
Terminal for wire 0_DY to ground	Continuity	Bad ground circuit.
<b>NOTE:</b> <i>Put the master disconnect switch and the ignition switch in the ON position.</i>		
Terminal for wire 19N_A at seat switch	24 volts	Check fuse N and accessory relay (16). Also check wire 19N_A and circuit 12P.
<b>NOTE:</b> <i>Put the seat compressor (82) switch in the ON position.</i>		
Terminal for wire from seat switch at compressor	24 volts	Bad seat switch, also check circuit from seat switch to compressor.
<b>NOTE:</b> <i>If the readings are good replace the seat compressor.</i>		

<b>83 – Blower Switch</b>		
<b>Check Points</b>	<b>Reading</b>	<b>Possible Cause of Bad Reading</b>
<b>NOTE:</b> <i>Put the master disconnect switch and the ignition switch in the ON position.</i>		
Terminal for wire 19G to ground	24 volts	Check fuse G and ignition relay No. 2 (15). Also check circuits 19G and 13R.
<b>NOTE:</b> <i>Turn the blower switch to LOW.</i>		
Terminal for wire 62L to ground	24 volts	Bad blower switch (83).
Terminal for wire 61T to ground	24 volts	Bad blower switch (83).
<b>NOTE:</b> <i>Turn the blower switch to MEDIUM.</i>		
Terminal for wire 62M to ground	24 volts	Bad blower switch (83).
Terminal for wire 61T to ground	24 volts	Bad blower switch (83).
<b>NOTE:</b> <i>Turn the blower switch to HIGH.</i>		
Terminal for wire 62H to ground	24 volts	Bad blower switch (83).
Terminal for wire 61T to ground	24 volts	Bad blower switch (83).

## TROUBLESHOOTING EXTERNAL LIGHTS AND SIGNALS, ROTARY LAMP SWITCH, AND CAB LIGHTS

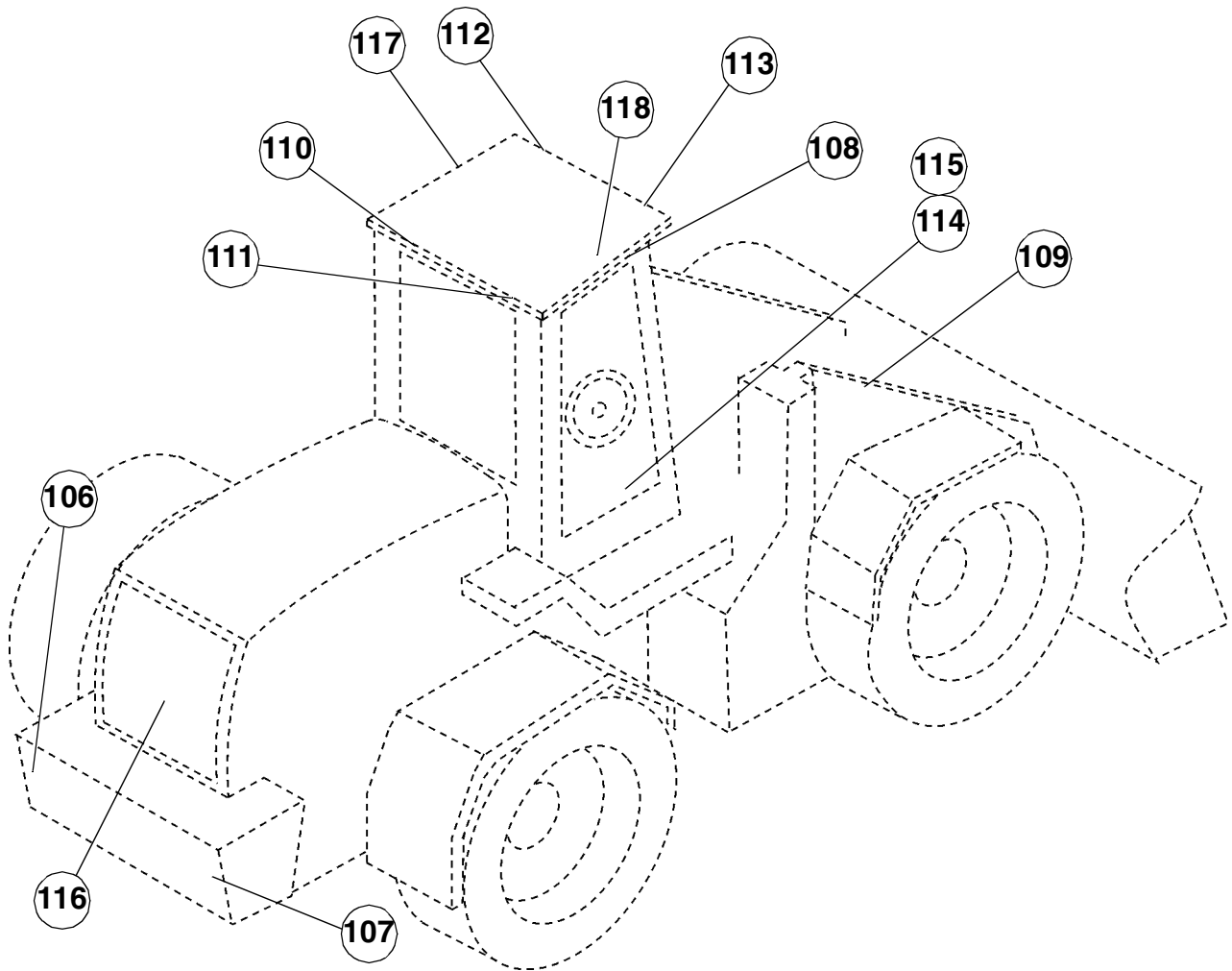

106. LH REAR COMBINATION LAMP  
 107. RH REAR COMBINATION LAMP  
 108. LH FRONT COMBINATION LAMP  
 109. RH FRONT COMBINATION LAMP  
 110. LH REAR WORK LAMP  
 111. RH REAR WORK LAMP  
 112. LH FRONT WORK LAMP

113. RH FRONT WORK LAMP  
 114. FIVE POSITION ROTARY LAMP SWITCH  
 115. HIGH/LOW BEAM RELAY NO. 13  
 116. LICENSE PLATE LAMP  
 117. DOME LAMP  
 118. COURTESY LAMP

BC00N140

**CONNECTOR 8 - RH FRONT COMBINATION LAMP TO FRONT CHASSIS HARNESS**

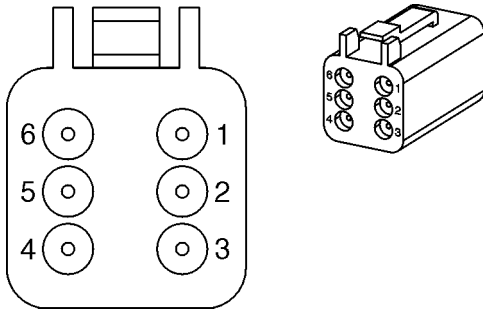

225351C1

CAV	WIRE IDENT	CIRCUIT
1	0_AG Bk-1.0	Lights Ground RH
2	18E Or-1.0	Low Beam RH
3	18C Or-1.0	High Beam RH
4	18G Or-1.0	Position RH
5	45R N-1.0	Right Turn Signal
6		None

**CONNECTOR 12F - RTD HARNESS FOR XT CHASSIS TO FRONT CHASSIS HARNESS**

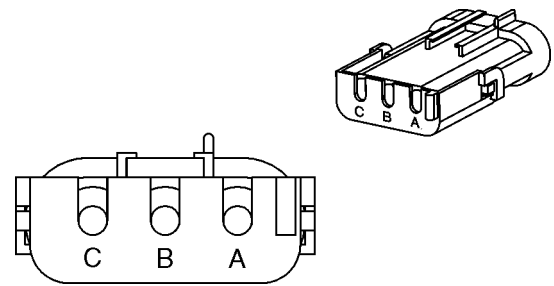

245485C1

CAV	WIRE IDENT	CIRCUIT
A	53B W-1.0	RTD Signal
B	0_AF Bk-1.0	RTD Ground
C	56_B W-1.0	RTD Power

**CONNECTOR 12M - RTD HARNESS FOR XT CHASSIS TO FRONT CHASSIS HARNESS**

**CONNECTOR 10 - HEIGHT CONTROL/RTT PROXIMITY SWITCH TO FRONT CHASSIS HARNESS**

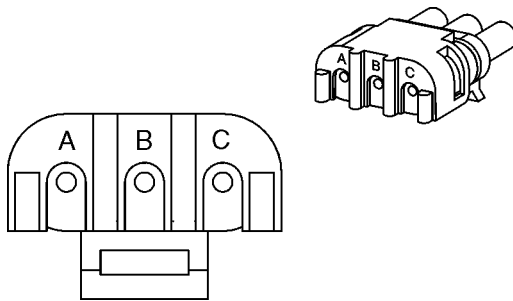

245484C1

CAV	WIRE IDENT	CIRCUIT
A	54B W-1.0	Height/RTT Signal
B	0_AA Bk-1.0	Height/RTT Ground
C	56_A W-1.0	Height/RTT Power

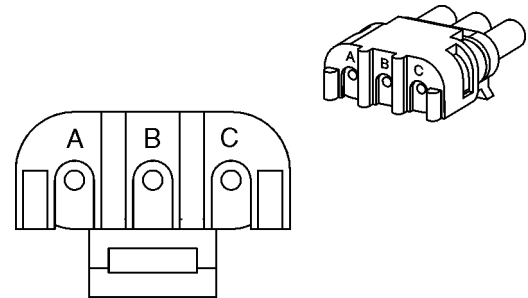

245484C1

CAV	WIRE IDENT	CIRCUIT
A	53B_A W-1.0	RTD Signal
B	0_AM Bk-1.0	RTD Ground
C	56_D W-1.0	RTD Power

**CONNECTOR 25F - FIVE POSITION ROTARY LAMP SWITCH TO CAB MAIN HARNESS**

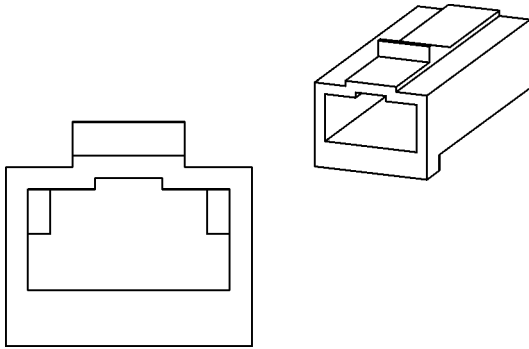

631801C1

CAV	WIRE IDENT	CIRCUIT
A	41J_B K-2.0	Driving Light Signal

**CONNECTOR 27M - AC LOW PRESSURE SWITCH TO CAB MAIN HARNESS**

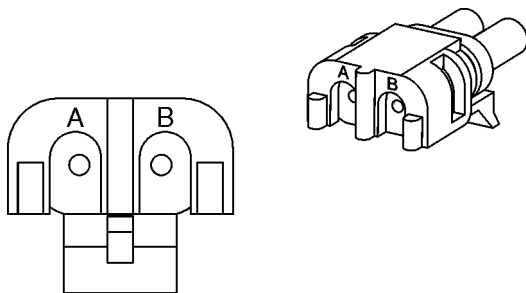

245482C1

CAV	WIRE IDENT	CIRCUIT
A	61R_E Or-0.8	AC Low Pressure Switch
B	61A_E Or-0.8	AC Low Pressure Switch

**CONNECTOR 28M - SEAT COMPRESSOR MOTOR TO CAB MAIN HARNESS**

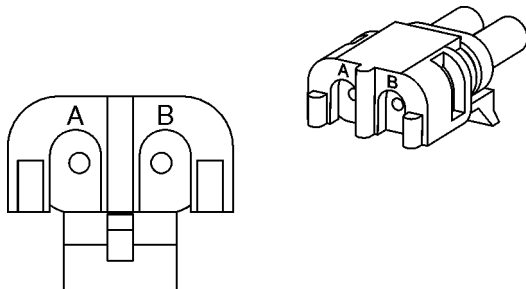

245482C1

CAV	WIRE IDENT	CIRCUIT
A	19N_A Or-1.0	Access Seat Fused Pwr (3 Way)
B	0_DY Bk-1.0	Blower Wpr Seat Ground

**CONNECTOR 29M - BLOWER MOTOR TO CAB MAIN HARNESS**

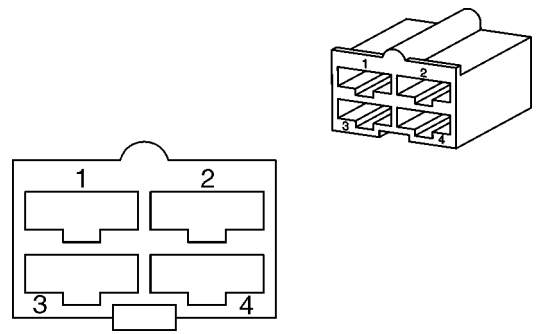

255058C1

CAV	WIRE IDENT	CIRCUIT
1	62L Or-1.0	Blower Low Speed
2	62M Or-2.0	Blower Medium Speed
3	62H Or-2.0	Blower High Speed
4	0_DZ Bk-2.0	Blwr Wpr Seat Ground

**CONNECTOR 30F - BLOWER SWITCH TO CAB MAIN HARNESS**

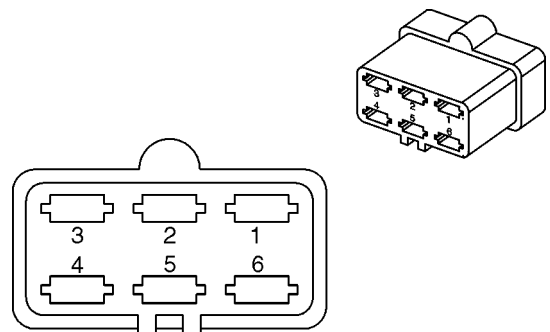

449797C1

CAV	WIRE IDENT	CIRCUIT
1		None
2	19G Or-2.0	Blower Switch Fused Power
3	62H Or-2.0	Blower High Speed
4	62M Or-2.0	Blower Medium Speed
5	62L Or-1.0	Blower Low Speed
6	61T Or-1.0	AC Thermostat Power

**CONNECTOR 65M - ETHER START  
TEMPERATURE SWITCH TO ETHER START  
SOLENOID**

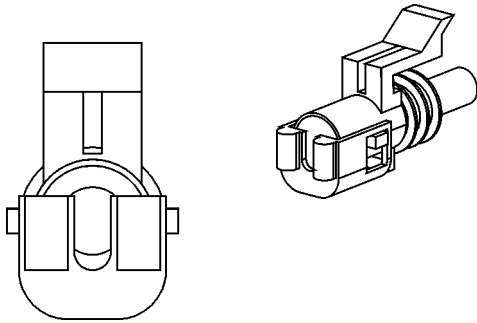

245480C1

CAV	WIRE IDENT	CIRCUIT
1	28T W-1.0	Ether Start Temp Switch

**CONNECTOR 68 - TURN SIGNAL SWITCH TO  
PEDESTAL HARNESS**

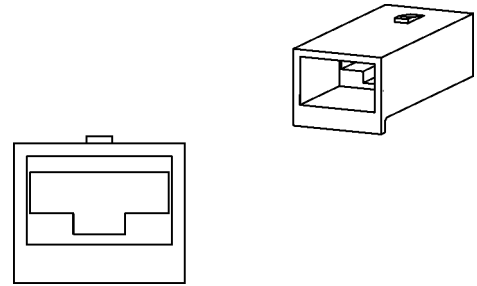

1964527C1

CAV	WIRE IDENT	CIRCUIT
1	45B N-0.8	Right Turn Switch Power

**CONNECTOR 66 - TURN SIGNAL SWITCH TO  
PEDESTAL HARNESS**

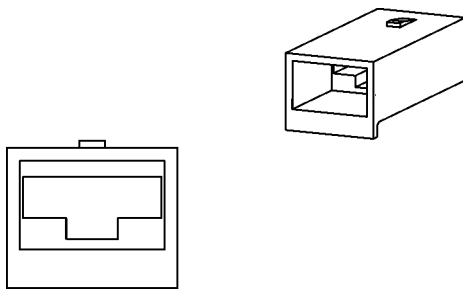

1964527C1

CAV	WIRE IDENT	CIRCUIT
1	45A N-0.8	Left Turn Switch Power

**CONNECTOR 69 - IGNITION SWITCH TO  
PEDESTAL HARNESS**

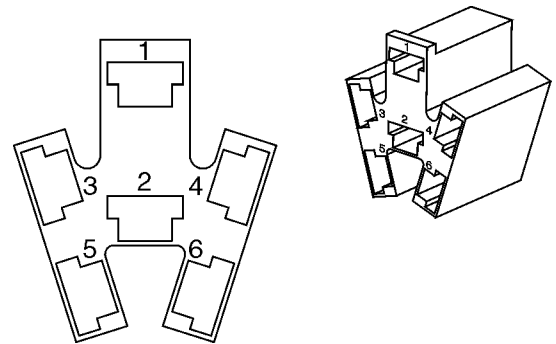

225253C1

CAV	WIRE IDENT	CIRCUIT
1	1A_A R-0.8 1A_B R-0.8	Ign Prog Reset Sw Power
2	21K W-0.8	Ign Switch Start Signal
3	13K Or-0.8	Ignition Switch Power
4	12K_C Or-0.8	Ign Switch Acc Power
5		None
6		None

**CONNECTOR 67 - TURN SIGNAL SWITCH TO  
PEDESTAL HARNESS**

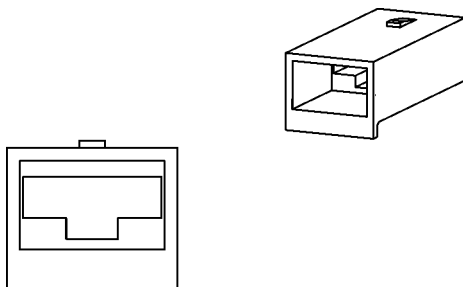

1964527C1

CAV	WIRE IDENT	CIRCUIT
1	19B Or-0.8	Turn Signal Power

**CONNECTOR 103 - ETHER START SOLENOID TO REAR CHASSIS HARNESS**

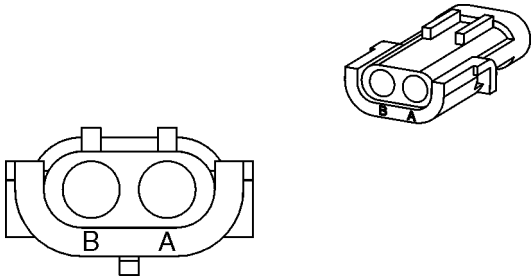

245483C1

CAV	WIRE IDENT	CIRCUIT
A	28P W-1.0	Ether Solenoid
B	28T_A W-1.0	Ether Start Temp Switch

**CONNECTOR 104 - COOLANT LEVEL SENDER TO REAR CHASSIS HARNESS**

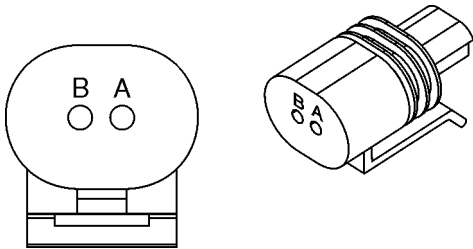

194788A1

CAV	WIRE IDENT	CIRCUIT
A	31D Y-1.0	Coolant Level Signal
B	0_V Bk-1.0	Fuel Rdndnt Brake Cool Ground

**CONNECTOR 107M - PIN ENGAGE SOLENOID TO FRONT CHASSIS HARNESS**

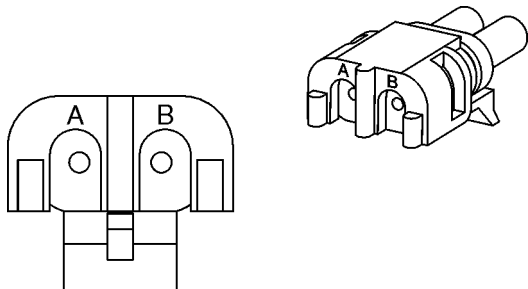

245482C1

CAV	WIRE IDENT	CIRCUIT
A	57 W-1.0	Pin Engage Solenoid Power
B	0_AB Bk-1.0	Pin Engage Ground

**CONNECTOR 108F - DIAGNOSTIC CONNECTOR TO CAB MAIN HARNESS**

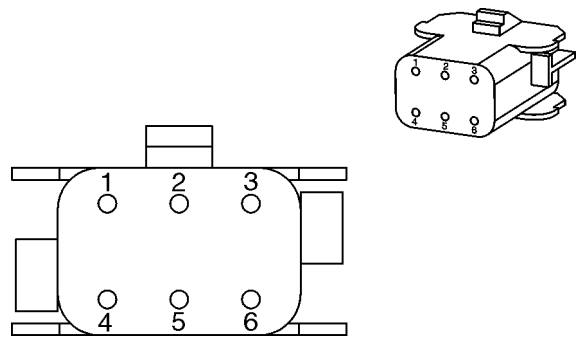

291663A1

CAV	WIRE IDENT	CIRCUIT
1	19A_L Or-0.8	Cab Switched Power
2	37D_A P-0.8	Diagnostic Signal
3	0_DAV Bk-0.8	Diagnostic TECM Ground
4	37E P-0.8	Diagnostic Signal
5		None
6		None

**CONNECTOR 109M - RADIO POWER CONVERTER TO RADIO HARNESS**

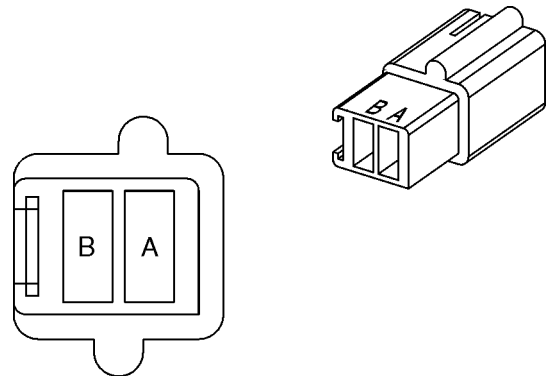

291730A1

CAV	WIRE IDENT	CIRCUIT
A	19L_A Or-1.0	Radio Power
B	0_PD Bk-1.0	Radio Ground

**CONNECTOR 210F - FAN REVERSER SWITCH TO CAB MAIN HARNESS**

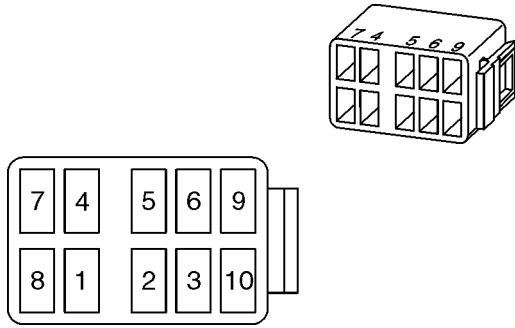

382391A1

CAV	WIRE IDENT	CIRCUIT
1		None
2	19P_B Or-1.0	Fan Rev Pin Engage Fused Pwr
3	52_A W-0.8	Fan Reverse Solenoid
4		None
5		None
6		None
7	0_DAF Bk-1.0 0_DAY Bk-1.0	Switch Ground
8	49_H S-0.8 49_U S-0.8	Pilot Light
9		None
10		None

**CONNECTOR 216F - ALTERNATOR RESISTOR TO CAB MAIN HARNESS**

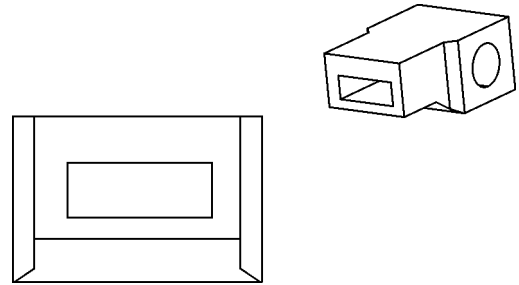

199436A1

CAV	WIRE IDENT	CIRCUIT
1	19R_E Or-0.8	Cab Switched Power

**CONNECTOR 217F - ENGINE SHUTDOWN JUMPER**

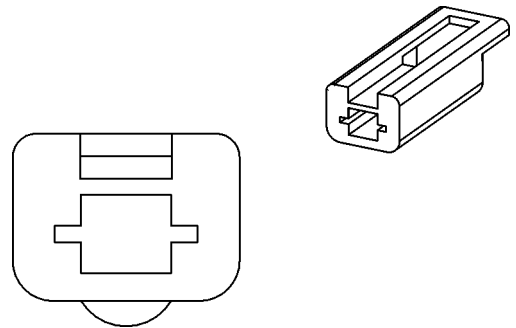

739070C1

CAV	WIRE IDENT	CIRCUIT
A	13K_D Or-0.8	Ignition Switch Power

**CONNECTOR 215F - ALTERNATOR RESISTOR TO CAB MAIN HARNESS**

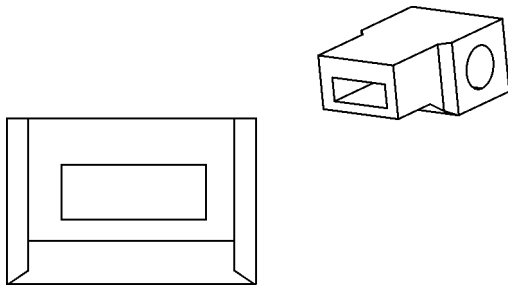

199436A1

CAV	WIRE IDENT	CIRCUIT
1	14_B LG-0.8	Alternator D+

**CONNECTOR 217M - ENGINE SHUTDOWN JUMPER**

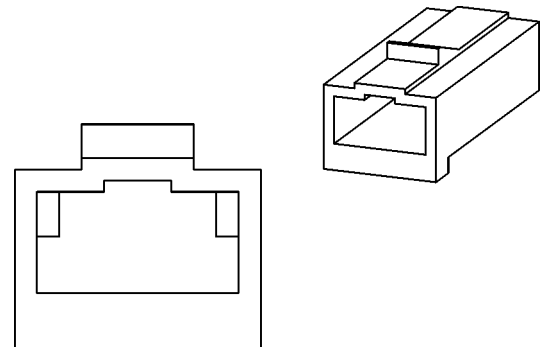

631801C1

CAV	WIRE IDENT	CIRCUIT
A	13C_B Or-0.8	Fuel Solenoid Power

# Section 4002

4002

## ELECTRICAL SPECIFICATIONS AND TROUBLESHOOTING

P.I.N. JEE0135501 AND ABOVE

CASE CORPORATION  
700 State Street  
Racine, WI 53404 U.S.A.

CASE CANADA CORPORATION  
3350 South Service Road  
Burlington, ON L7N 3M6 CANADA

Bur 6-48930

Copyright © 2003 Case Corporation  
Printed in U.S.A.  
February, 2003

Wire Identification Codes

21C Bk - 1.0

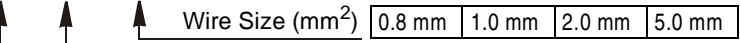

Wire Color		Bk = Black	DU = Dark Blue	S = Gray	LG = Light Green	K = Pink
Wire Name		T = Tan	W = White	N = Brown	G = Green	U = Blue
		LU = Light Blue	Or = Orange	R = Red	P = Purple	Y = Yellow

Wire Identification			From Connector		To Connector	
Wire	Circuit	Color, Size, and Material	Connector	Cavity	Connector	Cavity
0_DAT	Brk Lt Time Del Horn Grnd	Bk-0.8-SXL	220F Ground Cab	1	SPL_D14 Module Grnds	1
0_DAU	Analog Ground	Bk-0.8-SXL	22F Cab Transmission	30	13F Cab-Pedestal	8
0_DAV	Diag TECM Grnd	Bk-0.8-SXL	108F Diagnostic Connector	3	221F Ground Cab	1
0_DAW	Ground	Bk-1.0-SXL	42F Beacon Sw	7	118F Back-up Alarm Dis Sw	7
0_DAX	Beacon Wiper Diode Grnd	Bk-0.8-SXL	206F Cab Floor Weld Stud	1	140M Diode Module	C
0_DAY	Switch Grnd	Bk-1.0-SXL	210F Fan Reverser Sw	7	SPL_D13 Ground	1
0_DB	Can Pilot Sol Grnd	Bk-0.8-SXL	89M Pilot Pres Sol	B	219F Ground Cab	1
0-DBA	Grid Heater Lamp Grnd	Bk-0.8-SXL	13F Cab Pedestal	11	219F Ground Cab	1
0-DBB	Ground	Bk-0.8-SXL	201 Grid Htr Controller	8	202 Radio Ground	1
0_DC	Ac Brk Lt Time Delay Horn Grnd	Bk-0.8-SXL	204F Relay Brake Lamps	85	49F Accessory Relay	85
0_DD	Ride Cntrl Relay Sink	Bk-0.8-SXL	19F TECM	57	50F Ride Control Relay	85
0_DE	Relay Grnd	Bk-0.8-SXL	48F Ignition Relay #2	85	47F Ignition Relay #1	85
0_DF	Relay Grnd	Bk-0.8-SXL	49F Accessory Relay	85	48F Ignition Relay #2	85
0_DG	Ac Brk Lt Time Delay Horn Grnd	Bk-0.8-SXL	204F Relay Brake Lamps	85	58F Volt Meter Relay	85
0_DH	Relay Grnd	Bk-0.8-SXL	58F Volt Meter Relay	85	54F Neutral Start Relay	85
0_DJ	Relay Grnd	Bk-0.8-SXL	54F Neutral Start Relay	85	222F Ground Cab	1
0_DL	Signal Ground	Bk-0.8-SXL	22F Cab-Transmission	23	13F Cab-Pedestal	39
0_DM	Speed Sensor Grounds	Bk-0.8-SXL	19F TECM	3	22F Cab Transmission	11
0_DN	Out Speed Sensor Grnd	Bk-0.8-SXL	19F TECM	4	22F Cab Transmission	28
0_DP	Diag TECM Grnd	Bk-0.8-SXL	19F TECM	1	221F Ground Cab	1
0_DQ	Diag TECM Grnd	Bk-0.8-SXL	19F TECM	2	221F Ground Cab	1
0_DR	Dome Court Work Lt Grnd	Bk-1.0-SXL	24M Cab Roof	E	223F Ground Cab	1
0_DS	Dome Court Work Lt Grnd	Bk-1.0-SXL	24M Cab Roof	G	223F Ground Cab	1
0_DT	Dome Court Work Lt Grnd	Bk-1.0-SXL	23F Cab Roof	B	223F Ground Cab	1
0_DU	Beacon Wiper Diode Grnd	Bk-1.0-SXL	23F Cab Roof	C	206F Cab Floor Weld Stud	1
0_DV	Beacon Wiper Diode Grnd	Bk-0.8-SXL	206F Cab Floor Weld Stud	1	13F Cab-Pedestal	61
0_DW	Ground	Bk-0.8-SXL	45F Rear Wiper Sw	7	118F Back-up Alarm Dis Sw	7
0_DX	Horn Ground	Bk-0.8-SXL	13F Cab-Pedestal	41	220F Ground Cab	1
0_DY	Blwr Wiper Seat Grnd	Bk-1.0-SXL	28M Seat Comp Motor	B	218F Ground Cab	1
0_DZ	Blwr Wiper Seat Grnd	Bk-2.0-SXL	29M Blower Motor	4	218F Ground Cab	1
0_E	Fuel Redundant Br Cool Grnd	Bk-1.0-SXL	160 Engine Grounds	1	171 Fuel Sender Grnd	1

Wire Identification Codes

21C Bk - 1.0

Wire Size (mm<sup>2</sup>) 0.8 mm 1.0 mm 2.0 mm 5.0 mm

Wire Color	Bk = Black	DU = Dark Blue	S = Gray	LG = Light Green	K = Pink
	T = Tan	W = White	N = Brown	G = Green	U = Blue
	LU = Light Blue	Or = Orange	R = Red	P = Purple	Y = Yellow

Wire Identification			From Connector		To Connector	
Wire	Circuit	Color, Size, and Material	Connector	Cavity	Connector	Cavity
25R	Reverse Signal	LU-0.8-SXL	13M Pedestal-Cab	45	70 Transmission Shifter	C
25R_A	Reverse Signal	LU-0.8-SXL	19F TECM	64	13F Cab-Pedestal	45
25S	Output Sw Power VPS1	LU-0.8-TXL	22M Cab-Transmission	22	102 Trans Control	7
25S_A	Output Sw Power VPS1	LU-0.8-SXL	22F Cab-Transmission	22	SPL_D12 Common Power	1
25S_B	Output Sw Power VPS1	LU-0.8-SXL	19F TECM	12	SPL_D12 Common Power	1
25S_C	Output Sw Power VPS1	LU-0.8-SXL	19F TECM	13	SPL_D12 Common Power	1
25T_A	Neutral Signal	LU-0.8-SXL	92 Ether Switch	1	70 Transmission Shifter	D
25T_B	Neutral Signal	LU-0.8-SXL	13M Pedestal-Cab	46	92 Ether Switch	1
25T_C	Neutral Signal	LU-0.8-SXL	13F Cab-Pedestal	46	SPL_D18 Neutral Signal	1
25T_D	Neutral Signal	LU-0.8-SXL	19F TECM	67	SPL_D18 Neutral Signal	1
25T_E	Neutral Signal	LU-0.8-SXL	54F Neutral Start Relay	86	SPL_D18 Neutral Signal	1
25W	3rd And 4th Gear Signal	LU-0.8-SXL	13M Pedestal-Cab	48	183 Transmission Shifter	B
25W_A	3rd And 4th Gear Signal	LU-0.8-SXL	19F TECM	65	13F Cab-Pedestal	48
25Y	Trans Kickdown Signal	LU-0.8-SXL	13M Pedestal-Cab	50	183 Transmission Shifter	D
25Y_A	Trans Kickdown Signal	LU-0.8-SXL	13F Cab-Pedestal	50	SPL_D11 Trans Kick Down Signal	1
25Y_B	Trans Kickdown Sig	LU-0.8-SXL	19F TECM	22	SPL_D11 Trans Kick Down Signal	1
25Y_C	Trans Kickdown Signal	LU-0.8-SXL	20M Trans Kick-Down	2	SPL_D11 Trans Kick Down Signal	1
25Z	1st And 4th Gear Signal	LU-0.8-SXL	13M Pedestal-Cab	49	183 Transmission Shifter	C
25Z_A	1st And 4th Gear Signal	LU-0.8-SXL	19F TECM	63	13F Cab-Pedestal	49
26E	Trans Enable Signal	LU-0.8-SXL	19F TECM	31	199F Trans Enable Sw	3
26F_A	FNR Forward Signal	LU-0.8-SXL	198 FNR Switch	6	197M FNR-Main Cab	2
26F_B	FNR Forward Signal	LU-0.8-SXL	19F TECM	20	197F Main Cab FNR	2
26J	FNR Switch Jumper	LU-0.8-SXL	198 FNR Switch	2	198 FNR Switch	4
26N_A	FNR Neutral Signal	LU-0.8-SXL	198 FNR Switch	3	197M FNR-Main Cab	3
26N_B	FNR Neutral Signal	LU-0.8-SXL	19F TECM	44	197F Main Cab FNR	3
26R_A	FNR Reverse Signal	LU-0.8-SXL	198 FNR Switch	1	197M FNR-Main Cab	4
26R_B	FNR Reverse Signal	LU-0.8-SXL	19F TECM	30	197F Main Cab FNR	4
28C	Ether Start Control	W-0.8-SXL	13M Pedestal Cab	52	182 Ether Switch	1
28GC	Grid Heater Signal	W-0.8-SXL	SPL_D26 B+ Power	1	201 Grid Heater Controller	6
28GC_A	Grid Heater Signal	W-0.8-SXL	SPL_D26 B+ Power	1	21F Cab Rear	20
28GC_B	Grid Heater Signal	W-1.0-SXL	276F Relay Rear	A	21M Rear Cab	20

## UNDERSTANDING THE TROUBLESHOOTING TABLES

<b>1 – Alternator</b> <span style="border: 1px solid black; border-radius: 50%; padding: 2px 5px;">1</span>		
Check Points <span style="border: 1px solid black; border-radius: 50%; padding: 2px 5px;">2</span>	Reading <span style="border: 1px solid black; border-radius: 50%; padding: 2px 5px;">3</span>	Possible Cause of Bad Reading <span style="border: 1px solid black; border-radius: 50%; padding: 2px 5px;">4</span>
Check the 10 ampere fuse at location 3 and 4C in the fuse block.	Good	Bad fuse.
Terminal for wire 1A to ground	12 volts	Check wire 1A between the starter terminal (21) and the alternator (1).
<b>NOTE:</b> <i>If the readings are good, see Section 4004 and check the starter.</i>		

6
5

1. This title is the number and component name on the Electrical Schematic.
2. This column shows the location of the check point.
3. This column shows the indication of the check.
4. This column shows the possible cause of a bad test indication.
5. The numbers in the parentheses show the number of the component on the Electrical Schematic.
6. This statement assumes that all other problems are solved at this point in the test.

## LOCATING COMPONENTS ON THE SCHEMATIC POSTERS

**NOTE:** For the System Electrical Schematic refer to the Schematic Posters located at the rear of this manual.

Components can be located on the Electrical Schematic posters (rear pocket) by item number using the key at the bottom of the posters. Use the following index to find the sheet a component is located on.

COMPONENT	COMPONENT NUMBER	SCHEMATIC SHEET
12 Volt Radio (Option)	95	6
Accessory Relay No. 3	16	1
Air Conditioning High Pressure Switch	87	5
Air Conditioning Low Pressure Switch	86	5
Air Filter Restriction Switch	44	3
Alternator	4	1
Back-up Alarm	37	2
Back-up Alarm Disable Switch	36	2
Back-up Alarm Relay No. 7	35	2
Batteries	1	1
Beacon Switch	99	4
Blower Motor	85	5
Blower Motor Speed Resistors with Thermal Fuse	84	5

<b>12 – Neutral Start Relay No. 8</b>		
<b>Check Points</b>	<b>Reading</b>	<b>Possible Cause of Bad Reading</b>
Terminal for wire 0_DJ to ground	Continuity	Bad ground circuit.
<b>NOTE:</b> Put master disconnect switch and ignition switch in ON position. Make sure transmission is in NEUTRAL.		
Terminal for wire 25T_E to ground	24 volts	Check circuit 25T.
<b>NOTE:</b> Have another person hold the ignition switch in the START position.		
Terminal for wire 21K_A to ground	24 volts	Check circuit 21K_A and ignition switch.
Terminal for wire 21C_E to ground	24 volts	Bad neutral start relay (12).

<b>13 – Ignition Switch</b>		
<b>Check Points</b>	<b>Reading</b>	<b>Possible Cause of Bad Reading</b>
<b>NOTE:</b> Put the master disconnect switch in the ON position.		
Terminal for wire 1A to ground	24 volts	Check circuit 1A to 12.5 ampere circuit breaker A.
<b>NOTE:</b> Disconnect the connector from the ignition switch (13). Turn the switch to ON.		
Between Bat and Ign	Continuity	Bad ignition switch (13).
Between Bat and Acc	Continuity	Bad ignition switch (13).
<b>NOTE:</b> Hold the ignition switch (13) in the START position.		
Between Bat and Starter	Continuity	Bad ignition switch (13).
Between Bat and Ign	Continuity	Bad ignition switch (13).
<b>NOTE:</b> Put the switch in the Acc position.		
Between Bat and Acc	Continuity	Bad ignition switch (13).

<b>14 – Ignition Relay No. 1</b>		
<b>Check Points</b>	<b>Reading</b>	<b>Possible Cause of Bad Reading</b>
Terminal for wire 0_DE to ground	Continuity	Bad ground circuit.
<b>NOTE:</b> Put the master disconnect switch in the ON position. Turn the ignition switch to the ON position.		
Terminal for wire 1_S to ground	24 volts	Check circuit 1 to B+ stud.
Terminal for wire 13K_A to ground	24 volts	Check circuit 13K and ignition switch.
Terminal for wire 13P to ground	24 volts	Bad ignition relay No. 1 (14)

<b>47 – Instrument Cluster</b>		
<b>Check Points</b>	<b>Reading</b>	<b>Possible Cause of Bad Reading</b>
<b>NOTE:</b> <i>Disconnect the connector from the instrument cluster.</i>		
Connector terminal 3 to ground	Continuity	Bad brake warning pressure switch (38). Also check circuit 33P and ground circuit at brake warning pressure switch.
Connector terminal 4 to ground	Continuity	Bad coolant level sender (39). Also check circuit 31D and ground circuit at coolant level sender.
Connector terminal 5 to ground	Continuity	Bad secondary steering pressure switch (67). Also check circuit 35X and ground circuit at pressure switch.
Connector terminal 6 to ground	Open Circuit	Bad air filter restriction switch (44). Also check circuit 31F.
Connector terminal 7 to ground	Open Circuit	Bad hydraulic filter restriction switch. Also check circuit 31H.
Connector terminal 8 to ground	Continuity	Bad ground circuit. Check wires 0_KP, 0_DAV, 0_HC, and 0_BG.
Connector terminal 18 to ground	130 to 9500 ohms	Bad engine coolant temperature sender (43). Also check circuit 36C and ground circuit at sender.
Connector terminal 19 to ground	33 to 240 ohms	Bad fuel level sender (40). Also check circuit 36F and ground circuit at sender.
Connector terminal 20 to ground	130 to 9500 ohms	Bad hydraulic oil temperature sender (41). Also check circuit 36H and ground circuit at sender.
Connector terminal 21 to connector terminal 33	Continuity	Bad wire 50T.
Connector terminal 22 to ground	237 to 243 ohms	Bad engine oil pressure switch (50). Also check circuit 36P and ground circuit.
Connector terminal 28 to ground	Open Circuit	Bad redundant brake switche(s) (57). Also check circuit 33R.
Connector terminal 31 to terminals 26 and 27 on the transmission electronic control module (26)	Continuity	Bad circuit 50L.
Connector terminal 32 to terminal 25 on the transmission electronic control module (26)	Continuity	Bad circuit 50H.
Connector terminal 35 to ground	Continuity	Check LH and RH stop lamps and circuit 44. Also check ground circuit at lamps.
Connector terminal 37 to ground	Continuity	Bad ground circuit.
Connector terminal 38 to ground	Continuity	Bad ground circuit.
Connector terminal 39 to ground	Continuity	Bad ground circuit.
<b>NOTE:</b> <i>Put the master disconnect switch and the ignition switch in the ON position.</i>		
Connector terminal 1 to ground	24 volts	Bad fuse V. Also check circuit 19V.
Connector terminal 2 to ground	24 volts	Bad fuse S. Also check circuit 19S.
<b>NOTE:</b> <i>Put the parking brake switch in the ON position.</i>		
Connector terminal 9 to ground	24 volts	Bad parking brake switch. Also check fuse A and circuit 19A.

**63 – Height Control/Return-To-Travel Proximity Switch**

Check Points	Reading	Possible Cause of Bad Reading
<b>NOTE:</b> Disconnect the connector from the height control/return-to-travel proximity switch (63). Put the master disconnect switch and the ignition switch in the ON position. Put the pilot control switch (48) in the OFF position and the detent switch (59) in the ON position.		
Terminal B for wire 0_AA to ground	Continuity	Bad ground circuit.
Terminal A for wire 54B to ground	24 volts	Bad bucket control valve detent electromagnets (60) or detent switch (59). Also check circuit 54B.
Terminal C for wire 56_A to ground	24 volts	Bad detent switch (59). Also check circuit 56.
<b>NOTE:</b> If the readings are good, replace the height control/return-to-travel proximity switch (63).		

**64 – Float Pressure Switch**

Check Points	Reading	Possible Cause of Bad Reading
<b>NOTE:</b> Disconnect the wiring harness connector 178M from the float pressure switch.		
Between terminals of float pressure switch	Open Circuit	Bad float pressure switch.
<b>NOTE:</b> Start and run engine at idle speed. Put return-to-travel/float switch in FLOAT position. Put loader control lever in FLOAT position.		
Between terminals of float pressure switch	Continuity	Bad float pressure switch.
<b>NOTE:</b> Shut down engine. Put ignition switch in ON position. Put pilot control switch in OFF position (switch LED OFF).		
Wiring harness connector 178M, pin A and ground	24 volts	Bad pilot control relay. Also check wires 53P_C and 53P_D.

**65 – Float Solenoid**

Check Points	Reading	Possible Cause of Bad Reading
<b>NOTE:</b> Disconnect the wiring harness connector 179F from the float solenoid.		
Between terminals of float solenoid	37 to 43 ohms	Bad float solenoid.
Wiring harness connector 179F pin 2 to ground	Continuity	Bad ground circuit.
<b>NOTE:</b> Start and run engine at idle speed. Put return-to-travel/float switch in FLOAT position. Put loader control lever in FLOAT position.		
Wiring harness connector 179F pin 1 to ground	24 volts	Bad float pressure switch. Also check wires 53S_A and 53S_B.

# TROUBLESHOOTING HORN, BLOWER, AND AIR CONDITIONING

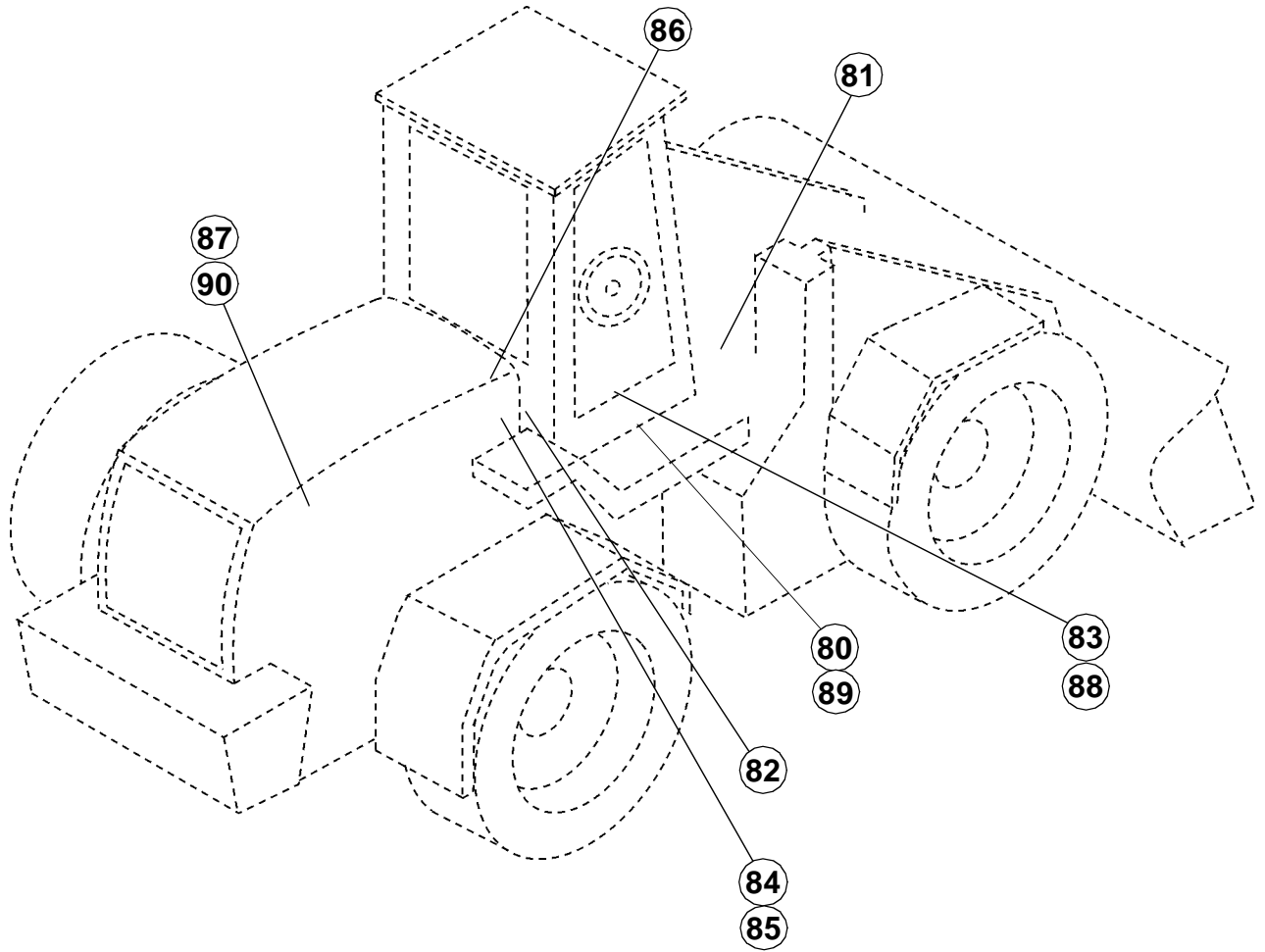

- 80. HORN RELAY NO. 5
- 81. HORN
- 82. SEAT COMPRESSOR
- 83. BLOWER SWITCH
- 84. SPEED RESISTOR
- 85. BLOWER MOTOR
- 86. A/C LOW PRESSURE SWITCH (IN CAB)
- 87. A/C HIGH PRESSURE SWITCH (IN REAR CHASSIS)
- 88. THERMOSTAT SWITCH
- 89. COMPRESSOR CLUTCH LOCKOUT RELAY NO. 14
- 90. COMPRESSOR CLUTCH

BC00N140

## 80 – Horn Relay No. 5

Check Points	Reading	Possible Cause of Bad Reading
Terminal for wire 19U_B to ground	24 volts	Check fuse U, also check wire 19U_B.
Terminal for wire 19U_C to ground	24 volts	Check wire 19U_C.
Terminal for wire 64C_A to ground	24 volts	Bad horn relay (80).
<b>NOTE:</b> Have another person push and hold the horn switch.		
Terminal for wire 64C_A to ground	0 volt	Bad horn switch.
Terminal for wire 64_A to ground	24 volts	Bad horn relay (80).

<b>105 – Flasher Module</b>		
<b>Check Points</b>	<b>Reading</b>	<b>Possible Cause of Bad Reading</b>
<b>NOTE:</b> <i>Wiring harness connectors 64F and 64M must be connected for North American Machines for opposite side steady on operation and disconnected for European machines for opposite side off operation.</i>		
Terminal for wire 0_DAN to ground	Continuity	Bad ground circuit.
Terminal for wire 0_DAQ to ground	Continuity	Bad ground circuit.
Terminal for wire 45N_A to terminal for wire 45N_B (North American machines only)	Continuity	Bad 45N circuit.
<b>NOTE:</b> <i>Put master disconnect switch in ON position.</i>		
Terminal for wire 1B_B to ground	24 volts	Check flasher circuit breaker B. Also check wires 1B_B and 1B_F.
<b>NOTE:</b> <i>Put ignition switch in the ON position. Put the hazard switch (103) ON.</i>		
Terminal for wire 45H_A to ground	24 volts	Bad hazard switch (103). Also check wires 45H_A and 45H.
Terminal for wire 45L_D to ground	Intermittent 24 volts	Bad flasher module (105).
Terminal for wire 45R_E to ground	Intermittent 24 volts	Bad flasher module (105).
<b>NOTE:</b> <i>Put hazard switch (103) in OFF position. Put turn signal switch (104) in RIGHT turn position.</i>		
Terminal for wire 45B_A to ground	24 volts	Bad turn signal switch (104) or fuse B. Also check wires 45B_A and 45B.
Terminal for wire 45R_E to ground	Intermittent 24 volts	Bad flasher module (105).
<b>NOTE:</b> <i>Put turn signal switch (104) in LEFT turn position.</i>		
Terminal for wire 45A_A to ground	24 volts	Bad turn signal switch (104) or fuse B. Also check wires 45A_A and 45A.
Terminal for wire 45L_D to ground	Intermittent 24 volts	Bad flasher module (105).

**CONNECTOR 2 - FRONT WASHER PUMP MOTOR TO REAR CHASSIS HARNESS**

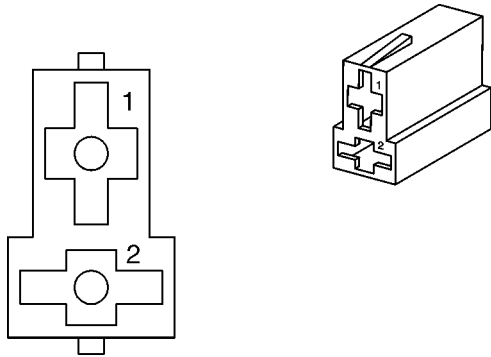

3227856R1

CAV	WIRE IDENT	CIRCUIT
1	63W Or-1.0	Front Washer Pump
2	0_G Bk-1.0	Front Rear Washer Hot Ground

**CONNECTOR 5F - RIDE CONTROL SOLENOID TO FRONT CHASSIS HARNESS**

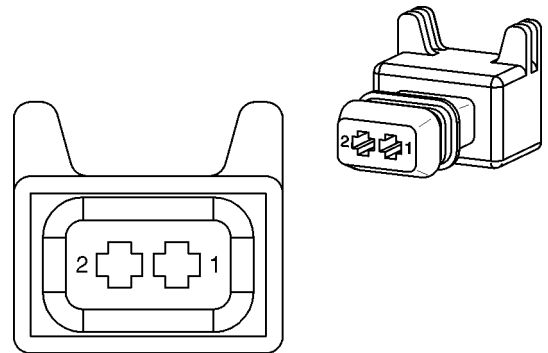

291718A1

CAV	WIRE IDENT	CIRCUIT
1	58_C W-1.0	Ride Control Solenoid Power
2	0_AC Bk-1.0	Ride Control Ground

**CONNECTOR 3 - REAR WASHER PUMP MOTOR TO REAR CHASSIS HARNESS**

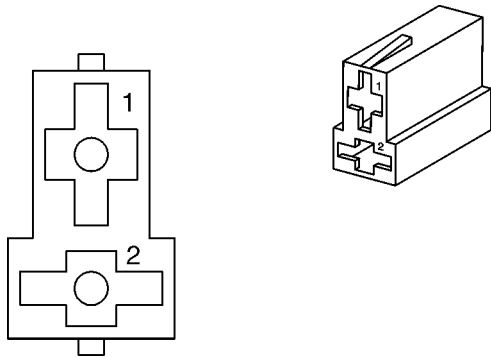

3227856R1

CAV	WIRE IDENT	CIRCUIT
1	68W Or-1.0	Rear Washer Pump
2	0_F Bk-1.0	Front Rear Washer Hot Ground

**CONNECTOR 6 - LH FRONT COMBINATION LAMP TO FRONT CHASSIS HARNESS**

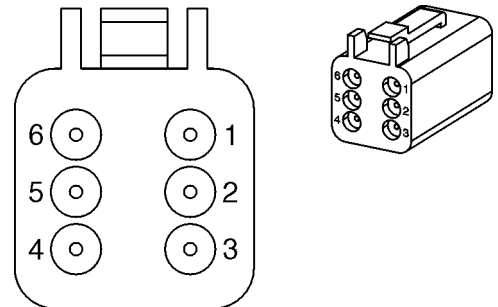

225351C1

CAV	WIRE IDENT	CIRCUIT
1	0_AL Bk-1.0	Lights Ground LH
2	18D Or-1.0	Low Beam LH
3	18B Or-1.0	High Beam LH
4	18F Or-1.0	Position LH
5	45L N-1.0	Left Turn Signal
6		None

**CONNECTOR 4 - BRAKE DECLUTCH PRESSURE SWITCH TO REAR CHASSIS HARNESS**

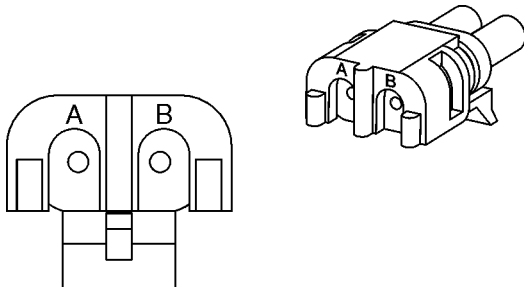

245482C1

CAV	WIRE IDENT	CIRCUIT
A	19A_A Or-1.0	Declutch Switch
B	25G LU-1.0	Declutch Switch

**CONNECTOR 23F - CAB MAIN HARNESS TO CAB ROOF HARNESS**

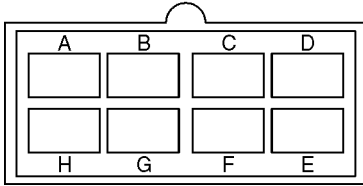
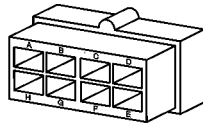

3195530R1

CAV	WIRE IDENT	CIRCUIT
A	68C_A Or-1.0	Rear Wiper Park
B	0_DT Bk-1.0	Dome Court Work Light Ground
C	0_DU Bk-1.0	Beacon Wiper Diode Ground
D	19U_A Or-1.0	Dome Light Horn Fused Power
E	46_A K-0.8 46_C K-1.0	Beacon Switched Power
F	19K_B Or-1.0	Rear Wiper Wash Fused Power
G	68L_A Or-1.0	Rear Wiper Low Speed
H	42R_B DU-0.8	Rear Work Light Power

**CONNECTOR 24F - CAB ROOF HARNESS TO CAB MAIN HARNESS**

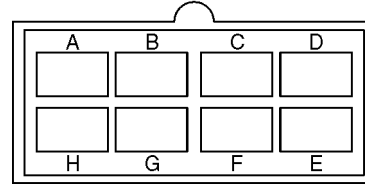
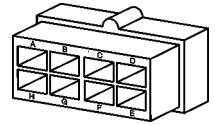

3195530R1

CAV	WIRE IDENT	CIRCUIT
A		None
B		None
C		None
D		None
E	0_MN Bk-0.8	Dome Courtesy Light Ground
F	49_V S-0.8	Courtesy Pilot Light
G	0_MK Bk-1.0	Front Work Light Ground
H	42C_D DU-1.0	Front Work Lights Power

**CONNECTOR 23M - CAB ROOF HARNESS TO CAB MAIN HARNESS**

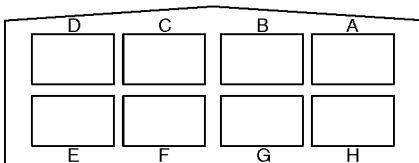
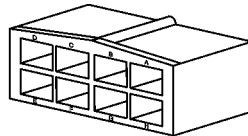

245430C1

CAV	WIRE IDENT	CIRCUIT
A	68C_B Or-1.0	Rear Wiper Park
B	0_MG Bk-1.0	Rear Work Light Ground
C	0_MD Bk-1.0	Beacon Rear Wiper Ground
D	19U_D Or-1.0	Dome Light Fused Power
E	46_D K-1.0	Beacon Switched Power
F	19K_E Or-1.0	Rear Wiper Wash Fused Power
G	68L_C Or-1.0	Rear Wiper Low Speed
H	42R_F DU-1.0	Rear Work Light Power

**CONNECTOR 24M - CAB MAIN HARNESS TO CAB ROOF HARNESS**

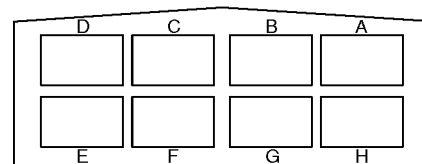
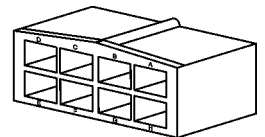

245430C1

CAV	WIRE IDENT	CIRCUIT
A		None
B		None
C		None
D		None
E	0_DR Bk-1.0	Dome Court Work Light Ground
F	49_S S-1.0	Courtesy Pilot Light
G	0_DS Bk-1.0	Dome Court Work Light Ground
H	42C_A DU-1.0	Front Flood Lights

**CONNECTOR 63M - TIME DELAY MODULE TO CAB MAIN HARNESS**

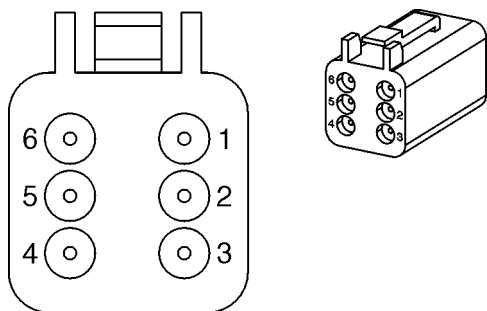

225351C1

CAV	WIRE IDENT	CIRCUIT
1	13D Or-1.0	Delay Power (2 Way)
2	1A_E R-0.8	Time Delay Power
3	0_DAS Bk 0.8	Time Delay Module Ground
4	37R_C P-0.8	Reset Signal
5	13K_F Or-0.8	Ignition Switch Power
6		None

**CONNECTOR 64F - FLASHER MODULE TO CAB MAIN HARNESS**

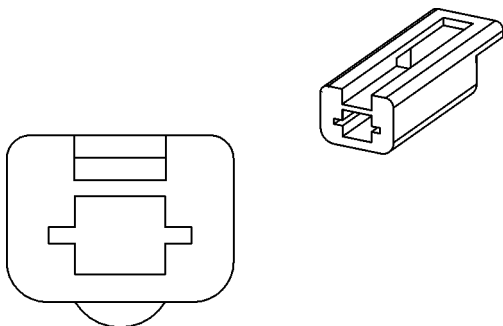

739070C1

CAV	WIRE IDENT	CIRCUIT
1	45N_A N-0.8	Flasher Opp Side Control

**CONNECTOR 64M - FLASHER MODULE TO CAB MAIN HARNESS**

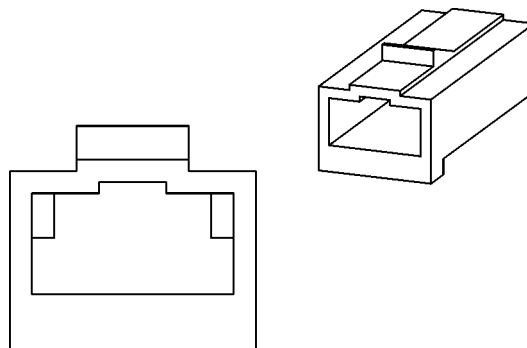

631801C1

CAV	WIRE IDENT	CIRCUIT
1	45N_B N-0.8	Flasher Opp Side Control

**CONNECTOR 66 - TURN SIGNAL SWITCH TO PEDESTAL HARNESS**

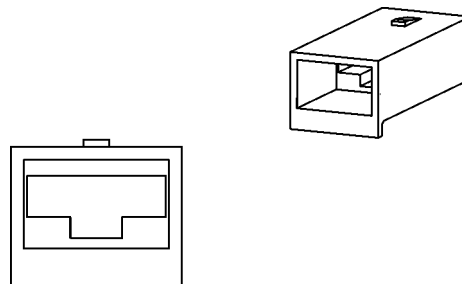

1964527C1

CAV	WIRE IDENT	CIRCUIT
1	45A N-0.8	Left Turn Switch Power

**CONNECTOR 67 - TURN SIGNAL SWITCH TO PEDESTAL HARNESS**

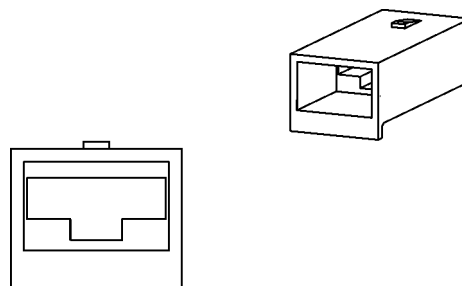

1964527C1

CAV	WIRE IDENT	CIRCUIT
1	19B Or-0.8	Turn Signal Power

**CONNECTOR 104 - COOLANT LEVEL SENDER TO REAR CHASSIS HARNESS**

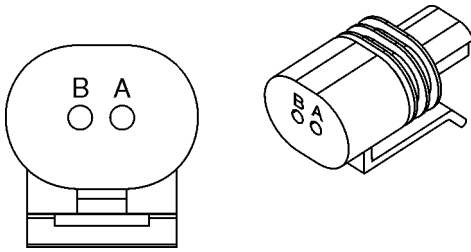

194788A1

CAV	WIRE IDENT	CIRCUIT
A	31D Y-1.0	Coolant Level Signal
B	0_V Bk-1.0	Fuel Rndnt Brake Cool Ground

**CONNECTOR 107M - PIN ENGAGE SOLENOID TO FRONT CHASSIS HARNESS**

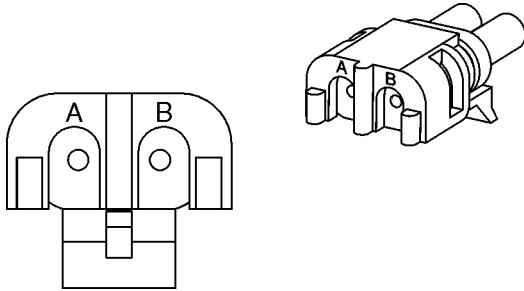

245482C1

CAV	WIRE IDENT	CIRCUIT
A	57 W-1.0	Pin Engage Solenoid Power
B	0_AB Bk-1.0	Pin Engage Ground

**CONNECTOR 108F - DIAGNOSTIC CONNECTOR TO CAB MAIN HARNESS**

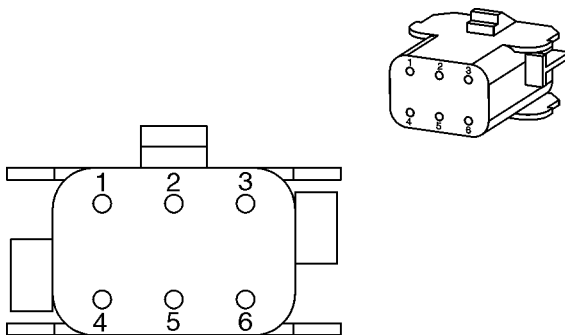

291663A1

CAV	WIRE IDENT	CIRCUIT
1	19A_L Or-0.8	Cab Switched Power
2	37D_A P-0.8	Diagnostic Signal
3	0_DAV Bk-0.8	Diagnostic TECM Ground

CAV	WIRE IDENT	CIRCUIT
4	37E P-0.8	Diagnostic Signal
5		None
6		None

**CONNECTOR 109M - RADIO POWER CONVERTER TO RADIO HARNESS**

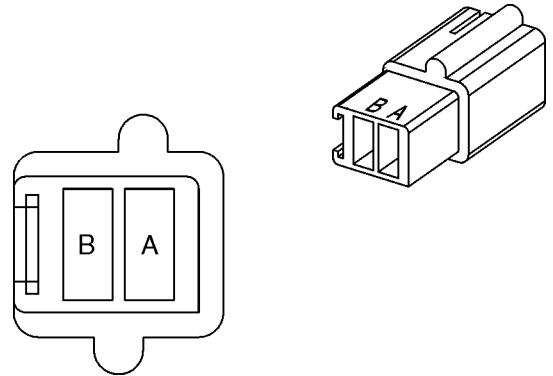

291730A1

CAV	WIRE IDENT	CIRCUIT
A	19L_A Or-1.0	Radio Power
B	0_PD Bk-1.0	Radio Ground

**CONNECTOR 110F - RADIO POWER CONVERTER TO RADIO HARNESS**

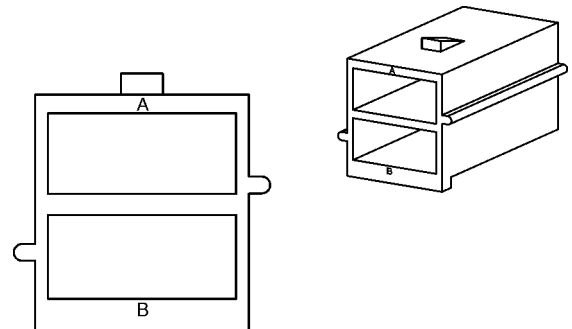

245426C1

CAV	WIRE IDENT	CIRCUIT
A	65C Or-0.8	Radio Power
B	0_PC Bk-0.8	Radio Ground

**CONNECTOR 210F - FAN REVERSER SWITCH TO CAB MAIN HARNESS**

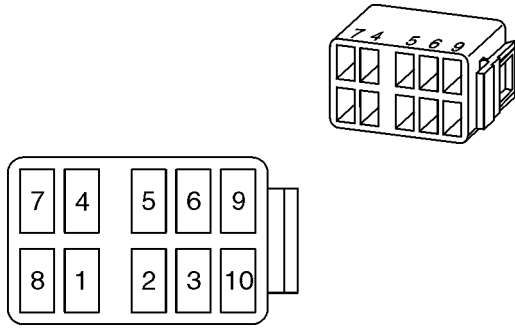

382391A1

CAV	WIRE IDENT	CIRCUIT
1		None
2	19P_B Or-1.0	Fan Rev Pin Engage Fused Pwr
3	52_A W-0.8	Fan Reverse Solenoid
4		None
5		None
6		None
7	0_DAF Bk-1.0 0_DAY Bk-1.0	Switch Ground
8	49_H S-0.8 49_U S-0.8	Pilot Light
9		None
10		None

**CONNECTOR 216F - ALTERNATOR RESISTOR TO CAB MAIN HARNESS**

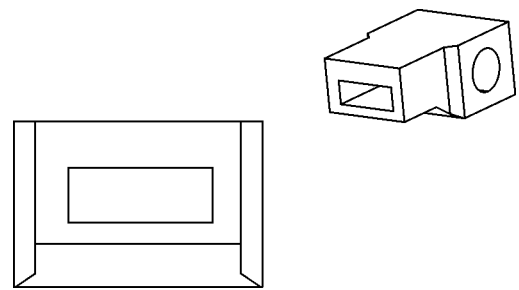

199436A1

CAV	WIRE IDENT	CIRCUIT
1	19R_E Or-0.8	Cab Switched Power

**CONNECTOR 217F - ENGINE SHUTDOWN JUMPER**

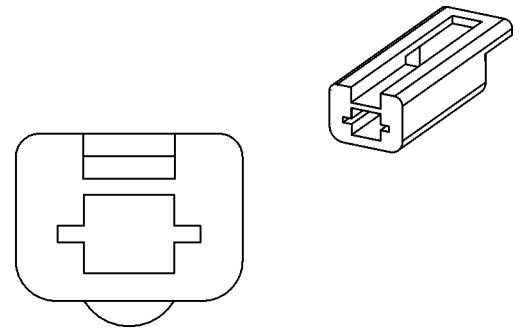

739070C1

CAV	WIRE IDENT	CIRCUIT
A	13K_D Or-0.8	Ignition Switch Power

**CONNECTOR 215F - ALTERNATOR RESISTOR TO CAB MAIN HARNESS**

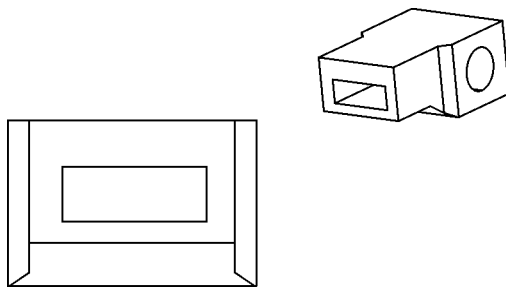

199436A1

CAV	WIRE IDENT	CIRCUIT
1	14_B LG-0.8 14_C LG-0.8	Alternator D+

**CONNECTOR 217M - ENGINE SHUTDOWN JUMPER**

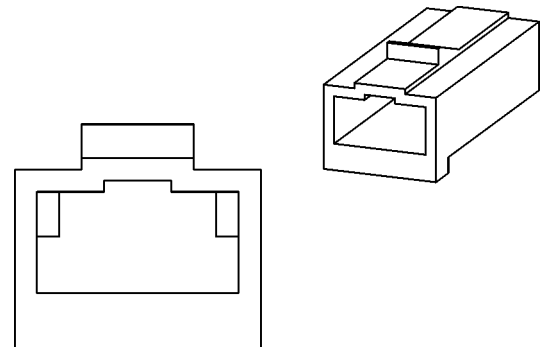

631801C1

CAV	WIRE IDENT	CIRCUIT
A	13C_B Or-0.8	Fuel Solenoid Power

Brake Lamp Pressure .....	79
Brake Warning Pressure .....	48
Declutch .....	45
Declutch Brake .....	45
Detent.....	59
Engine Oil Pressure .....	55
Fan Reversing .....	56
Filter Maintenance.....	45
Five Position Rotary Lamp .....	88
Float Pressure .....	61
FNR.....	45
Front Wiper and Washer .....	69
Fuel Filter Heater .....	39
Hazard.....	80
Hi/Low Beam.....	80
Horn .....	80
Hydraulic Filter Restriction .....	49
Ignition.....	41
Master Disconnect .....	37
Parking Brake.....	50
Pilot Control Switch .....	53
Pin Engage.....	65
Program Reset .....	50
Proximity, Height Control/Return-To-Travel .....	61
Proximity, Return-To-Dig.....	60
Rear Wiper and Washer.....	70
Redundant Brake Pressure .....	57
Return-To-Travel/Float.....	60
Ride Control .....	66
Seat Compressor .....	72
Secondary Steering Pressure .....	63
Transmission Auto .....	45
Transmission Enable.....	45
Transmission Kick-down .....	45
Turn Signal.....	80
Up/down Count .....	53

## T

Temperature Sensor	
Grid Heater.....	40
Thermal Fuse	
Blower Motor .....	73
Thermostat .....	74
Thermostat Switch.....	74
Time Delay Module.....	43
Torque Converter Output Temperature Sender .....	45
Transmission Auto Switch .....	45
Transmission Electronic Control Module .....	45
Transmission Enable Switch .....	45
Transmission Kick-down Switch .....	45
Transmission Shifter .....	45
Transmission Solenoid Valve and Temperature	
Sensors .....	45
Turbine Speed Sensor.....	45
Turn Signal Switch.....	80

## U

Understanding the Troubleshooting Tables .....	31
Up/down Count Switch .....	53

## V

Voltmeter Relay No. 12 .....	43
------------------------------	----

## W

Wiper	
Front Motor.....	68
Front Switch .....	69
Front Washer Pump Motor.....	69
Front Washer Switch.....	69
Rear Motor .....	70
Rear Switch.....	70
Rear Washer Pump Motor .....	70
Rear Washer Switch .....	70

# Section 4005

**INFORMATION AND DIAGNOSTIC CENTER**

**4005**

## SETTINGS, DIAGNOSTICS, AND FAULT CODES

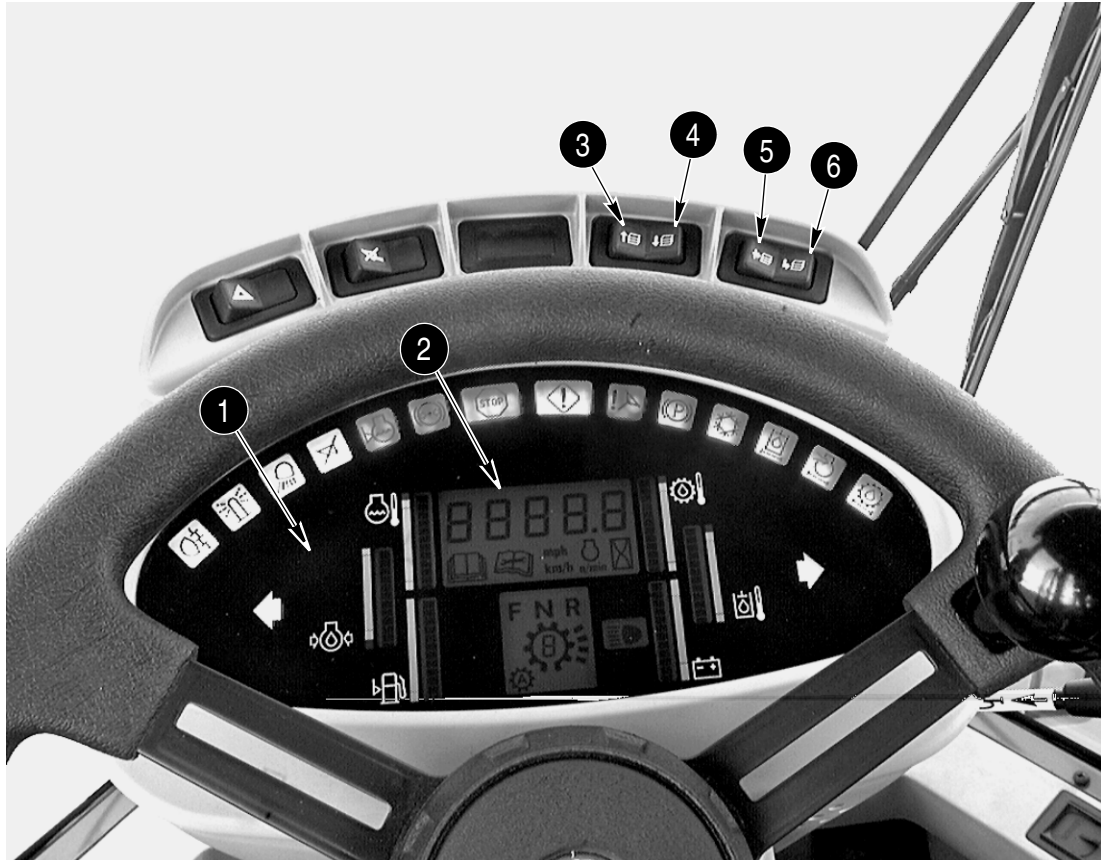

- |                       |               |            |
|-----------------------|---------------|------------|
| 1. INFORMATION CENTER | 3. UP COUNT   | 5. PROGRAM |
| 2. DISPLAY CENTER     | 4. DOWN COUNT | 6. RESET   |

RD98K316

**FIGURE 3. INFORMATION CENTER**

### Programming the Information Center

**NOTE:** The machine must be OFF prior to programming the information center.

Two switches are used during the programming of the information center: the up/down count switch and the program/reset switch. These switches are located on the right hand side of the information center, refer to Figure 3.

For an up count press the left side of the up/down count switch. For a down count press the right side of the up/down count switch. The center position is OFF or NEUTRAL.

For programming press the left side of the program/reset switch. For resetting press the right side of the program/reset switch. The center position is OFF or NEUTRAL.

To program the information center do the following steps:

1. Turn the machine OFF.
2. Turn the key to the RUN position.
3. Press the program/reset switch to program.
4. Press the up/down count switch to up count program location 010.
5. Center the program/reset switch to OFF.
6. Note the gauge display setting that is displayed, 01, 02, 03, 04, or 05. If the desired setting has already been selected go to step 7.
7. Press the up/down count switch to up count to choose one of the following gauge display settings:

## Display Location Numbers (048 and 049) Reserved for Future Use

### Minimum Gear Selection

Do the following procedures to program the transmission for the lowest gear possible in the automatic mode.

**NOTE:** *The 1st or 2nd gear can be selected. The gear that is selected will be the gear that the transmission is in when the machine begins to move. The factory minimum gear setting is 1.*

1. Press the program/reset switch to program.
2. Press the up/down count switch to up count until the display reads 050.
3. Place the program/reset switch in the OFF (center) position.
4. Read the number (1 or 2) shown on the Information Center. If this is the desired gear selection, press the program/reset switch to either program or reset.
5. If you want the other minimum gear selection, press the up/down count switch to up count.
6. Press the program/reset switch momentarily (0.25 seconds) to reset.

### Maximum Gear Selection

Do the following procedures to program the transmission for the highest gear possible in the automatic mode.

**NOTE:** *The 2nd, 3rd, or 4th gear can be selected. The gear that is selected will be the highest attainable gear that the transmission will be able to reach. The factory maximum gear setting is 4.*

1. Press the program/reset switch to program.
2. Press the up/down count switch to up count until the display reads 051.
3. Place the program/reset switch in the OFF (center) position.
4. Read the number (2, 3, or 4) shown on the Information Center. If this is the desired gear selection, press the program/reset switch to either program or reset.
5. If you want a different maximum gear selection, press the up/down count switch to up count until the desired number is displayed.
6. Press the program/reset switch momentarily (0.25 seconds) to reset.

## Gear Range Read Only

Do the following procedures to read the gear range.

1. Press the program/reset switch to program.
2. Press the up/down count switch to up count until the display reads 052. The operational indicator will flash intermittently.
3. Place the program/reset switch in the OFF (center) position.
4. The Information Center will read 1 or 2 (gears).
5. Press the program/reset switch to program.
6. Press the up/down count switch to up count until the display reads 053. The operational indicator will flash intermittently.
7. Place the program/reset switch in the OFF (center) position.
8. The Information Center will read 2,3, or 4 (gears).

## Display Location Number 054 Reserved for Future Use

### Reset Diagnostic Stack for Locations 071 through 090

Do the following procedure to remove all diagnostic codes from field number locations 071 through 090.

1. Press the program/reset switch to program.
2. Press the up/down count switch to up count until the display reads 055. The service indicator will flash intermittently.
3. Place the program/reset switch in the OFF (center) position.
4. Press the up/down count switch to up count until the display reads 21.
5. Press the program/reset switch to reset. If there are diagnostic codes in field number locations 071 through 090 they will be removed, unless the condition still exists.

## FAULT CODES

CODE	DEFINITION	POSSIBLE STEPS FOR REPAIR
12110	Engine coolant temperature is 110° C (230° F) or greater	Troubleshoot electrical circuits.
12900	Engine coolant short circuit measuring less than 50 ohms to the engine coolant temperature sensor.	
12901	Engine coolant open circuit measuring greater than 10,000 ohms to the engine coolant temperature sensor with hydraulic oil temperature at 40° C (104° F) or more.	
13000	Low engine coolant level - This code will not be generated if the engine coolant temperature is below 20° C (68° F).	<ol style="list-style-type: none"> <li>1. A critical stop function warning has occurred.</li> <li>2. Red stop indicator comes on and continuous buzzer sounds.</li> <li>3. Stop machine and perform required service on the critical area.</li> </ol>
21070	Engine oil pressure is measured below 70 kPa (10 psi)	
21900	Engine oil pressure short circuit measuring less than 16 ohms to the engine oil pressure sensor.	<p>Troubleshoot electrical circuits.</p> <p><b>NOTE:</b> <i>Fault code 21900 is possible during cold engine start-up. After machine warm up, verify proper operation.</i></p>
21901	Engine oil pressure open circuit measuring more than 270 ohms to the engine oil pressure sensor.	
33900	Fuel level short circuit measuring less than 16 ohms to the fuel level sender.	Troubleshoot electrical circuits.
33901	Fuel level open circuit measuring more than 270 ohms to the fuel level sender.	
34000	Fuel solenoid output short circuit.	
35000	High air filter restriction.	<ol style="list-style-type: none"> <li>1. A caution level warning has occurred.</li> <li>2. Yellow caution indicator comes on and buzzer sounds for 3 seconds.</li> <li>3. Perform required service on the cautioned area.</li> </ol>
42125	Transmission temperature measured above 125° C (257° F)	<ol style="list-style-type: none"> <li>1. A critical stop function warning has occurred.</li> <li>2. Red stop indicator comes on and continuous buzzer sounds.</li> <li>3. Stop machine and perform required service on the critical area.</li> </ol>
45000	High transmission filter restriction when the transmission oil is above 20° C (68° F).	<ol style="list-style-type: none"> <li>1. A caution level warning has occurred.</li> <li>2. Yellow caution indicator comes on and buzzer sounds for 3 seconds.</li> <li>3. Perform required service on the cautioned area.</li> </ol>
46017	Gear range fault error	<ol style="list-style-type: none"> <li>1. Check the cables from TCU to shift lever.</li> <li>2. Check signal combinations of shift lever positions for gear range.</li> </ol>
46018	Logical error at direction select signal	<ol style="list-style-type: none"> <li>1. Check the cables from TCU to shift lever.</li> <li>2. Check signal combinations of shift lever positions F-N-R.</li> </ol>

# INDEX

**A**

- Actual Gear Check ..... 18
- Air Conditioning
  - Indicator ..... 7
  - Switch Check ..... 17
- Air Filter
  - Indicator ..... 7
  - Restriction Switch Check ..... 16
- Alarm Check ..... 15
- Automatic Scrolling Gauge Displays ..... 12

**B**

- Beacon
  - Indicator ..... 6
  - Status ..... 19
- Brake
  - Park, Indicator ..... 7
  - Park, Information Center Output Check ..... 16
  - Park, Testing ..... 12
  - Pressure ..... 15
  - Pressure Indicator ..... 6

**C**

- Calibration
  - Speedometer ..... 24
  - Transmission Clutch ..... 13
- Caution and Warning Master Indicator Lights ..... 19
- Caution Master Indicator (Yellow) ..... 6
- Check
  - Actual Gear ..... 18
  - Air Conditioning Switch ..... 17
  - Alarm ..... 15
  - Coolant Level ..... 15
  - Fog Lights ..... 17
  - Park Brake Switch ..... 20
  - Requested Gear ..... 17
  - Switch, Pilot Lockout ..... 20
  - Switch, Redundant Brake Pressure ..... 20
  - Switch, Service Brake Foot ..... 20
  - Work Lights ..... 16
- Clutch
  - Calibration, Transmission ..... 13
- Control
  - Pilot ..... 6
- Coolant
  - Engine Temperature ..... 8
  - Indicator, Low ..... 6
- Coolant Level Check ..... 15
- Critical Warning Displays ..... 3

**D**

- Diagnostic Indicator Status ..... 19
- Display Center
  - Lighting, Setting ..... 15

- Display Location
  - 047 ..... 20
  - 048 and 049 ..... 21
  - 054 ..... 21
  - 056 through 060 ..... 22
  - 071 through 090 ..... 21
  - 097 ..... 23
  - 100 through 199 ..... 23
  - 104 through 113 ..... 24
  - 117 through 120 ..... 24
  - 121 through 129 ..... 24
  - 131 through 139 ..... 25
  - 140 through 170 ..... 25
  - 191 through 196 ..... 26
  - 197 ..... 26
  - 198 ..... 26
  - 199 ..... 26
- Displays
  - Gauge, Automatic Scrolling ..... 12
  - Gauge, Manual Scrolling ..... 12
  - Individual Function ..... 12
- Drive Line Shift Status ..... 18
- Duty Cycle
  - LCD ..... 23
  - LED ..... 23

**E**

- Engine
  - Coolant Temperature ..... 8, 10
  - Oil Pressure ..... 10
  - Oil Pressure Gauge ..... 8
- Entry Code
  - Test Mode Locations 100 to 199 ..... 23

**F**

- Fault Code Status ..... 22
- Filter
  - Indicator, Air Filter ..... 7
  - Indicator, Hydraulic Oil ..... 7
  - Indicator, Transmission Oil ..... 7
  - Restriction Switch, Air ..... 16
  - Restriction Switch, Hydraulic ..... 16
  - Restriction Switch, Transmission ..... 17
- Fog Lights Check ..... 17
- Fuel
  - Gauge ..... 8
  - Level ..... 10

**G**

- Gauge
  - Engine Oil Pressure ..... 8
  - Fuel Level ..... 8
  - Hydraulic Oil Temperature ..... 7
  - Transmission Oil Temperature ..... 7
  - Voltmeter ..... 8

14. Check the rotor shaft for damage. Make sure that the coils are not loose on the shaft. Check the slip rings for too much wear or deep grooves. The slip rings can be cleaned by using fine 400 grit sand paper.
15. Connect one of the test leads from an ohmmeter to the rotor shaft (ground). Connect the other test lead to one of the slip rings. There must not be any electrical connection between the slip ring and the rotor shaft. The ohmmeter reading must not be low or zero ohms. If the ohmmeter reading is low or zero ohms, replace the rotor assembly. Repeat this test on the other slip ring.
16. Connect an ohmmeter between the two slip rings. The reading on the ohmmeter must be 8 to 9 ohms. If the reading on the ohmmeter is high, there is a break in the rotor coil and the rotor assembly will have to be replaced.
17. Remove the rear bearing (25) from the rotor (24) using a bearing puller.
18. Remove the front bearing (27) and spacer (23) by using a bearing puller and hydraulic press.
19. Remove the bearing retaining plate (28).
20. Check the capacitor (18) for continuity between the mounting tab and the lead. If there is continuity, the capacitor (18) is bad. Check the capacitor (18) by connecting an ohmmeter between the mounting tab and lead. The ohmmeter will initially show movement and then return to indicating no continuity as the capacitor (18) is charged. Discharge the capacitor (18) by grounding the lead to the tab before installation.
21. Check for continuity between each brush (14) and the brush terminal. If there is no continuity, replace the brushes (14).
22. Measure the length of the brush (14) projecting from the brush holder and voltage regulator (12). Replace the brushes if the length is 7 mm (0.27 inch) or less.
23. Use a soldering iron to disconnect the brush lead. Remove the brush (14) and the spring (13) from the brush holder and voltage regulator (12).
24. Install a new brush (14) and spring (13) in the brush holder and voltage regulator (12). Solder lead to terminal using rosin-cored solder. Clamp rubber tube in terminal next to the solder point. Test for easy movement of brushes after installation. Brushes will project 14 mm (0.55 inch) from holder.
25. Remove the nuts (29), washers (30), nuts (31), washers (32) and fiber washers (33) from the rectifier bridge terminals.
26. Remove the insulator (35) from the B+ terminal (40).
27. Remove the rectifier screws (36) that hold the rectifier bridge (37) to the rear housing (21). Remove the rectifier bridge (37) from the rear housing (21).
28. Remove the insulator (35) from the B+ terminal (40).
29. Remove the insulator (38) from the D+ terminal (39).
30. Unsolder the stator coil (44) at the connections to the rectifier bridge (37). Remove the stator coil (44).

**NOTE:** *Bend phase lead-out wires as little as possible.*

31. Test the positive diodes in the rectifier bridge (37). Connect the negative lead of the ohmmeter to the output B+ terminal (40). Connect the positive lead of the ohmmeter to one of the leads for the positive diodes. The positive diodes are the seven diodes closest to the B+ terminal (40).
32. Reverse the ohmmeter leads. Read the ohmmeter. There must be a high reading and a low reading. If the readings are the same, replace the rectifier bridge (37). Repeat this step for the other six diodes.

**NOTE:** *D+ terminal (39) must be installed on a new rectifier bridge (37).*

33. Check the negative diodes in the rectifier bridge (37). Connect the negative lead of the ohmmeter to the surface of the diode plate that is not painted. Connect the positive lead of the ohmmeter to one of the leads for the negative diodes. The negative diodes are the seven diodes on the side of the rectifier bridge (37) opposite the B+ terminal (40).

**NOTE:** *When soldering leads to the terminals, the solder must not flow into copper leads.*

## Inspection of the Brushes

### STEP 21

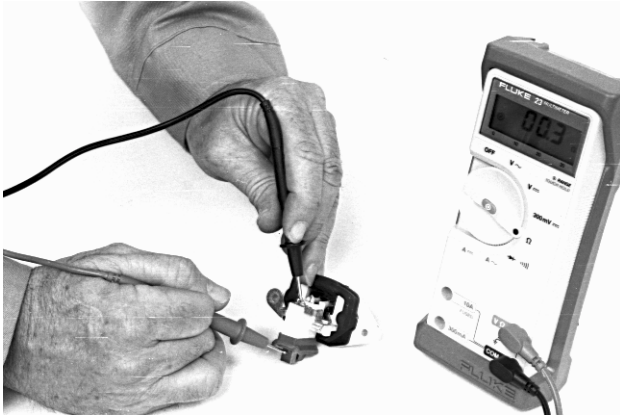

B9064411M

Use an ohmmeter and check the continuity from each terminal and brush. If the reading is not zero, replace the brush or voltage regulator and brush holder.

### STEP 22

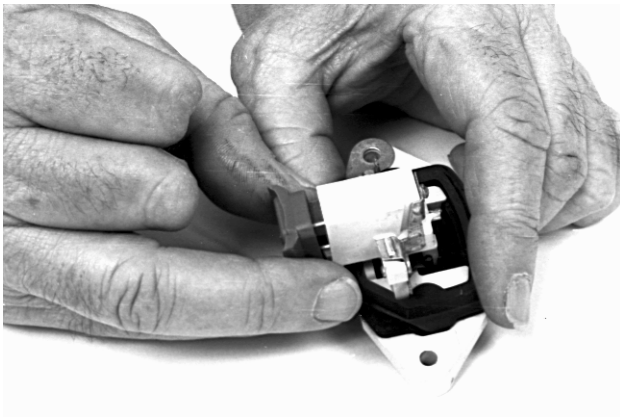

B9064414M

Remove the shield.

### STEP 23

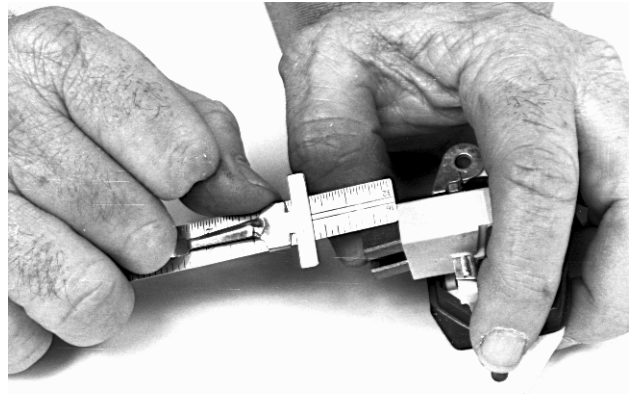

B9064418M

Measure the length of each brush. If one brush is less than 7 mm (0.27 inch) long replace both brushes or the voltage regulator and brush holder.

### STEP 24

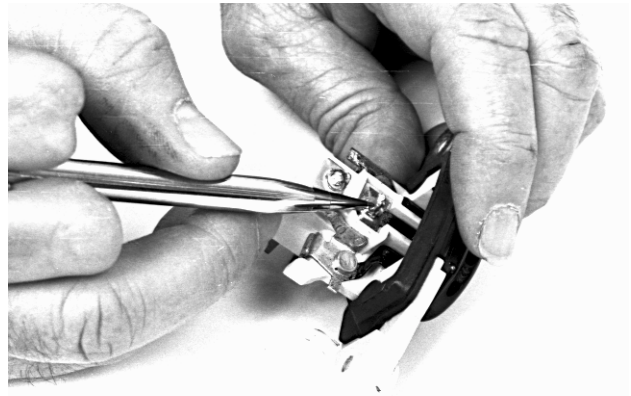

B9064421M

To replace the brushes, use a soldering iron to remove the original brushes. Install the springs and new brushes and use rosin core solder to solder the leads to the terminals. Before soldering the terminal shown, open the sleeve for the brush lead and then crimp the sleeve.

### STEP 25



B9064414M

Install the shield.

**NOTES**

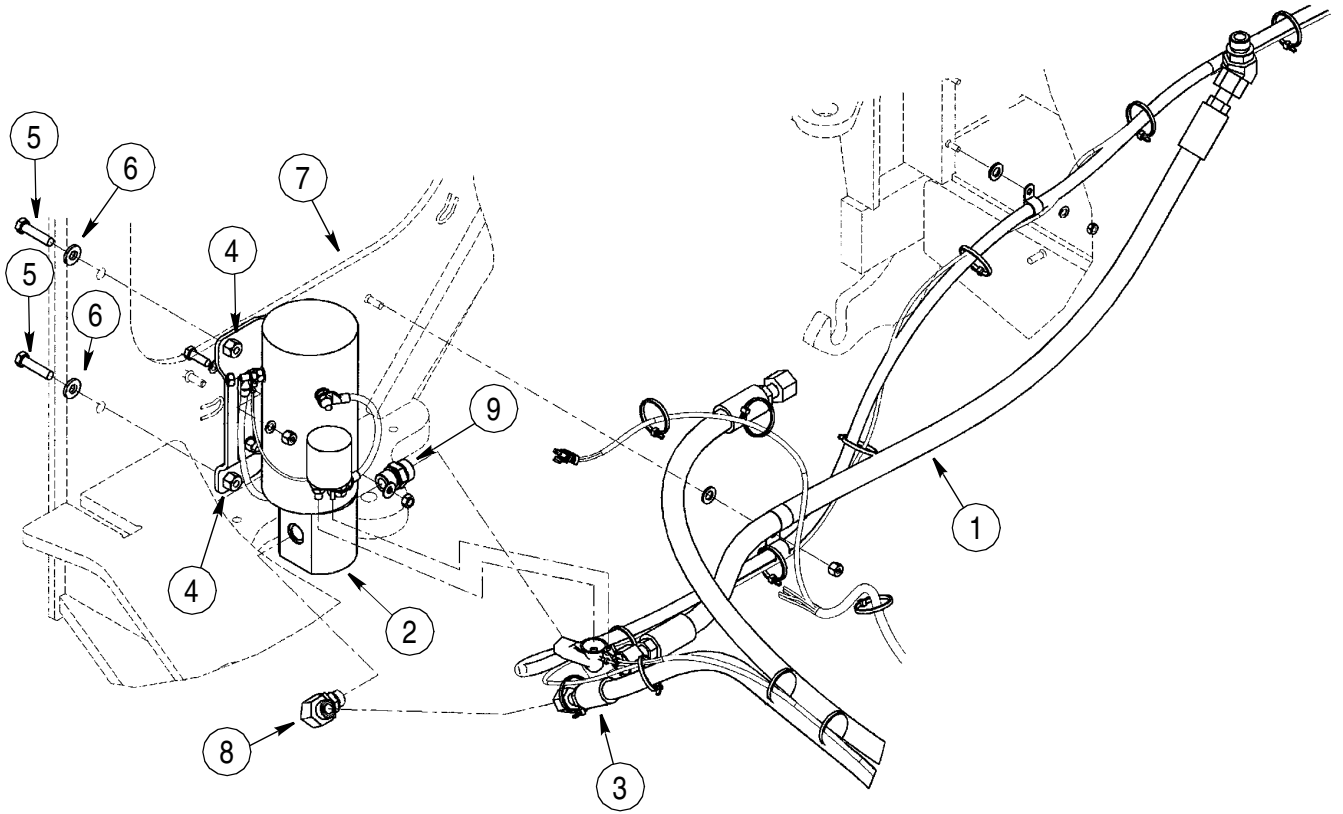

- |                                      |           |                 |
|--------------------------------------|-----------|-----------------|
| 1. HOSE                              | 4. NUT    | 7. REAR CHASSIS |
| 2. AUXILIARY STEERING PUMP AND MOTOR | 5. BOLT   | 8. ELBOW        |
| 3. HOSE                              | 6. WASHER | 9. FITTING      |

**AUXILIARY STEERING PUMP AND MOTOR ILLUSTRATION**

BS01C106

## STEERING RELIEF VALVE

**NOTE:** The pump differential pressure must be properly adjusted before doing this test. Refer to Section 8002 Testing and Adjusting the Pump Differential Pressure.

### Pressure Setting Test

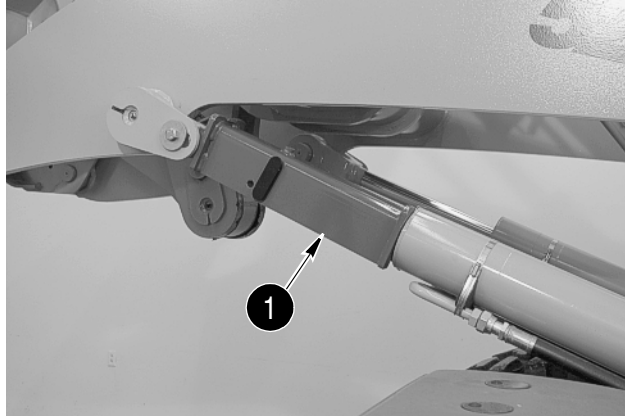

BD00M048

1. SAFETY LINK

1. Install the safety link (1) and lower the loader arms slowly, until the safety link is supporting the loader arms.



BD00M041

1. COVER PLATE

2. Remove the cover plate (1) to gain access to the loader control valve.

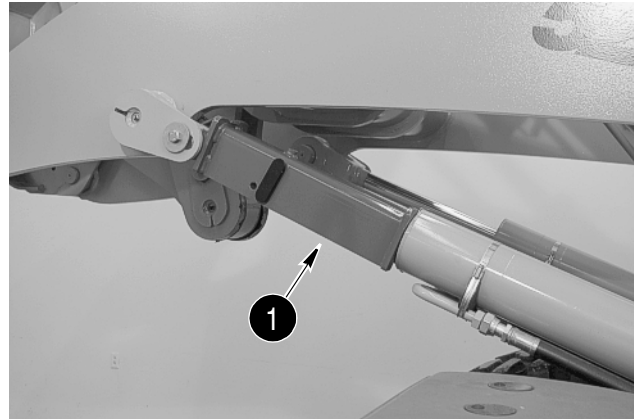

BD00M048

1. SAFETY LINK

3. Remove the safety link (1) and lower the loader arms to the ground.
4. Stop the engine.

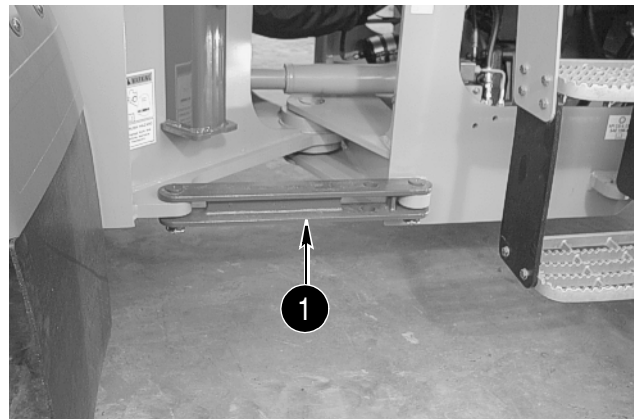

BD00M030

1. ARTICULATION LOCK

5. Install articulation lock (1).

**IMPORTANT:** When performing the following pressure check and adjustment, the articulation lock must be installed. Use caution when working in or near the articulation area.

CLICK HERE TO **DOWNLOAD** THE COMPLETE MANUAL

- Thank you very much for reading the preview of the manual.
- You can download the complete manual from: [www.heydownloads.com](http://www.heydownloads.com) by clicking the link below



- Please note: If there is no response to CLICKING the link, please download this PDF first and then click on it.

CLICK HERE TO **DOWNLOAD** THE COMPLETE MANUAL

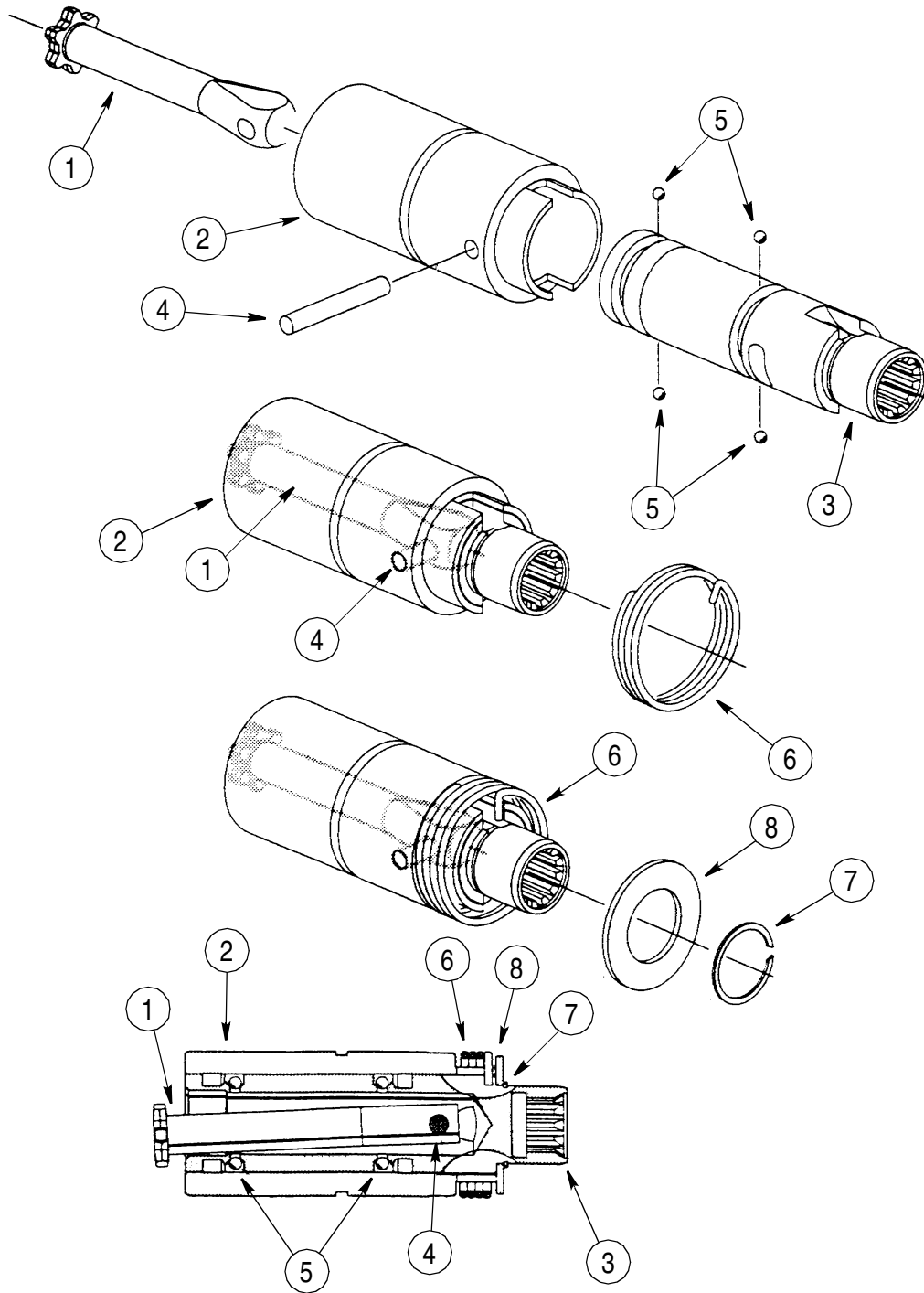

- |                |                     |
|----------------|---------------------|
| 1. DRIVE SHAFT | 5. BALL CHECK       |
| 2. SLEEVE      | 6. CENTERING SPRING |
| 3. SPOOL       | 7. RETAINING RING   |
| 4. PIN         | 8. BEARING RACE     |

**FIGURE 5. SPOOL AND SLEEVE ASSEMBLY**

GS98K505

## Assembly

1. Install the seal (4) in the gland (3). The seal (4) must be installed so that the lips of the seal (4) are toward the small end of the gland (3). The seal (4) can be difficult to install. Use tools that will not damage the seal (4). Refer to the illustration on page 4.
  2. Install the seal (5) in the gland (3).
  3. Install the guide (8) in the gland (3).
  4. Install the wiper (9) in the gland (3).
  5. Install the O-ring (6) on the gland (3). The O-ring (6) must be toward the small end of the gland (3).
  6. Install the backup ring (7) on the gland (3). The backup ring (7) must be toward the large end of the gland (3). If the backup ring (7) is not flat on both sides, the side that is not flat must be toward the O-ring (6).
  7. Fasten the yoke on the piston rod (10) in the vise.
  8. Lubricate the piston rod (10) and the bore in the gland (3) with clean hydraulic oil.
- NOTE:** *If a new gland (3) is being installed, write the part number of the cylinder on the gland (3).*
9. Push the gland (3) onto the piston rod (10). If necessary, use a soft hammer to drive the gland (3) onto the piston rod (10).
  10. Put the support below and near the end of the piston rod (10). Put a cloth between the support and the piston rod (10) to prevent damage to the piston rod (10).
  11. Install a new wear ring (14) on the piston (11).
  12. Install a new backup ring (13) on the piston (11).
  13. Install a new seal (12) over the backup ring (13).
  14. Clean the threads on the end of the piston rod (10) and the threads of the bolt (15) using Loctite cleaning solvent. Allow to dry. Apply Loctite 242 to the piston rod threads 1/4 inch from the open end of the piston rod so that there is 1/2 inch of Loctite 242 on the piston rod threads. **DO NOT** apply Loctite to the first 1/4 inch of the piston rod threads.
  15. Install the bolt (15) and hardened washer (16) in the piston (11).
  16. Install the piston (11) on the piston rod (10) and start the bolt (15) into the piston rod (10).
  17. Tighten the bolt (15) according to torque specifications listed on page 2.
  18. Fasten the tube (1) in the vise. Be careful not to damage the tube (1).
  19. Apply petroleum jelly to the O-ring (6) and backup ring (7) on the gland (3) and to the sealing surface in the tube (1).
  20. Lubricate the piston (11) and the inside of the tube (1) with clean hydraulic oil.
  21. Push the piston (11) straight into the tube (1). Be careful not to damage the wear ring (14) and seal (12) on the piston (11).
  22. When the piston (11) is in the smooth part of the tube (1), start the gland (3) into the tube (1).
  23. Tighten the gland (3) to 339 to 475 Nm (250 to 350 pound-feet).

43. Apply grease to the lower pivot pin (10). See Specifications in this section.
44. Install the lower pivot pin (10) in the bottom pivot.
45. Hold the bottom spacer (14) in place and lubricate the bottom pivot until grease is forced out of the seal (6).
46. Rotate the lower pivot pin (10) to check the bearing assembly. The lower pivot pin (10) must rotate smoothly, but not easily.
47. Remove the lower pivot pin (10) and the upper pivot pin (4).
48. Remove the bottom spacer (14).

## **CONNECTING THE FRONT FRAME TO THE REAR FRAME**

1. Release the parking brake.
2. Move the rear frame into alignment with the front frame.
3. Move the steering cylinders as required to move the rear frame into alignment with the front frame.
4. Apply the parking brake.
5. Apply grease to the upper pivot pin (4), refer to Figure 1.
6. Install the upper pivot pin (4), spacer (3), washer (2) and bolt (1). Be careful not to damage the seal (6).
7. Tighten the bolt (1) to 220 to 250 Nm (162 to 184 pound-feet).
8. Apply grease to the lower pivot pin (10).
9. Install the lower pivot pin (10) in the frames. Be careful not to damage the seal (6).
10. Use the ram and hand pump to install the bottom spacer (14). See Special Tools in this section.
11. Install the lower pin plate (15), three inner bolts (1), and washers (2) that fasten the lower pin plate (15) to the lower pivot pin (10).
12. Tighten the bolts (1) to 69 Nm (51 pound-feet).
13. Measure the gap between the lower pin plate (15) and the bottom pivot. Make a record of the measurement. Subtract 0.0762 to 0.1016 mm (0.003 to 0.004 inch) from the measurement. Select shims equal to that value.
14. Loosen the bolts (1) that fasten the lower pin plate (15) to the lower pivot pin (10).
15. Start the six outer bolts (1) into the lower pin plate (15) and the bottom pivot.
16. Install the shims (8).
17. Tighten the six outer bolts (1) to 128 to 136 Nm (94 to 100 pound-feet).
18. Tighten the three inner bolts (1) to 124 Nm (92 pound-feet).
19. Remove the jacks from the rear frame.
20. Remove the blocks from the rear axle.
21. Remove the stands from the front frame.
22. Put the drive shaft in position on the front yoke.
23. Install new Ferry head screws that fasten the drive shaft to the front yoke.
24. Tighten the Ferry head screws to 61 to 81 Nm (45 to 60 pound-feet).
25. Put the steering cylinder rod eye in position in the frame. Install the washer between the steering cylinder rod eye and the rear frame.
26. Align the hole in the pivot pin with the holes in the steering cylinder rod eye, and install the pivot pin.
27. Install the bolt and self-locking nut that hold the pivot pin.
28. Repeat steps 25, 26 and 27 for the other steering cylinder.
29. Start the vacuum pump.
30. Connect the return hose.
31. Connect the supply hose.
32. Put the bracket for the hoses in position on the rear frame. Install the bolts, flat washers, and self-locking nuts that fasten the bracket to the rear frame.
33. Put the bracket for the hoses in position on the front frame.
34. Install the bolts, flat washers, and self-locking nuts that fasten the bracket to the front frame.
35. Connect the hoses for the steering cylinders.
36. Connect the brake hose for the front brakes at the front bracket.
37. Stop the vacuum pump.
38. Connect the front wiring harness to the rear wiring harness.

## TABLE OF CONTENTS

SPECIAL TORQUES .....	2
TRANSMISSION .....	3
Removal .....	3
Transmission Mounting .....	10
Installation .....	11
FRONT AXLE .....	18
Removal .....	18
Front Axle Mounting .....	20
Installation .....	21
REAR AXLE .....	23
Removal .....	23
Rear Axle Mounting .....	25
Installation .....	26

## SPECIAL TORQUES

RH and LH Mounting Brackets to Transmission Mounting Bolts .....	481 to 590 Nm (355 to 435 lb-ft)
Top Mounting Bracket to Transmission Mounting Bolts .....	251 to 319 Nm (185 to 235 lb-ft)
Transmission Mounting Brackets to Chassis Mounting Bolts .....	.890 to 1000 Nm (655 to 735 lb-ft)
Engine Drive Shaft to Transmission Mounting Bolts .....	34 to 41 Nm (25 to 30 lb-ft)
Fuel Supply Hose Clamp .....	3.4 Nm (30 lb-inch)
Fuel Return Hose Clamp .....	3.4 Nm (30 lb-inch)
Transmission Fill Tube Mounting Bolts .....	.17 to 33 Nm (12 to 24 lb-ft)
Rear Drive Shaft to Transmission Mounting Bolts .....	.61 to 81 Nm (45 to 60 lb-ft)
Center Drive Shaft to Transmission Mounting Bolts .....	.61 to 81 Nm (45 to 60 lb-ft)
Front Axle Mounting Bolts	
P.I.N. JEE0135500 and Below .....	.845 to 950 Nm (625 to 700 lb-ft)
P.I.N. JEE0135501 and Above .....	.955 to 1075 Nm (705 to 790 lb-ft)
Wheel Bolts	
Preliminary Torque .....	.298 Nm (220 lb-ft)
Final Torque .....	.640 to 720 Nm (475 to 530 lb-ft)
Center Bearing Mounting Bolts .....	.99 to 128 Nm (73 to 94 lb-ft)
Front Drive Shaft Mounting Bolts .....	.61 to 81 Nm (45 to 60 lb-ft)
Pivot Pin Caps Mounting Bolts .....	.251 to 280 Nm (185 to 205 lb-ft)
Rear Drive Shaft to Rear Axle Mounting Bolts .....	.61 to 81 Nm (45 to 60 lb-ft)

**STEP 40**

**NOTE:** In this step, new straps (73) and bolts (72) must be installed whenever these parts are removed. Bolts have a nylon patch to maintain torque which requires new bolts.

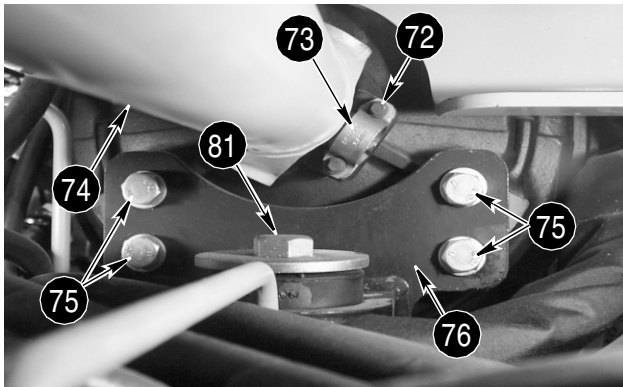

BD01D342

Using 3/4 inch drive socket, extensions, and impact wrench, install four washers and bolts (75) to secure top mounting bracket (76) to transmission. Then tighten bolts (75) to a torque of 251 to 319 Nm (185 to 235 lb-ft). If bracket (76) had been removed, tighten bolt (81) to a torque of 890 to 1000 Nm (655 to 735 lb-ft). Connect engine drive shaft (74) to transmission. Install two new straps (73) and four new bolts (72). Tighten bolts (72) to a torque of 34 to 41 Nm (25 to 30 lb-ft).

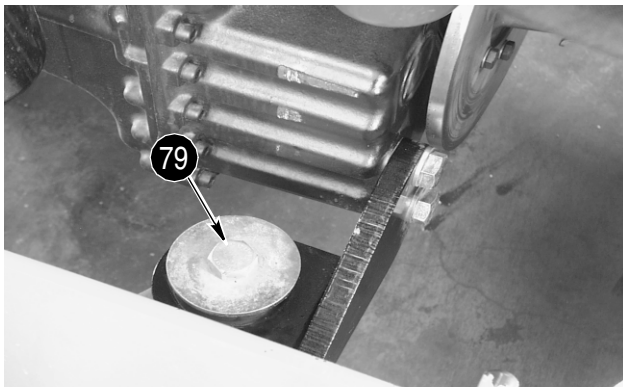
**STEP 41**

BD01D337

Tighten bolts (79) securing RH and LH mounting brackets to a torque of 890 to 1000 Nm (655 to 735 lb-ft).

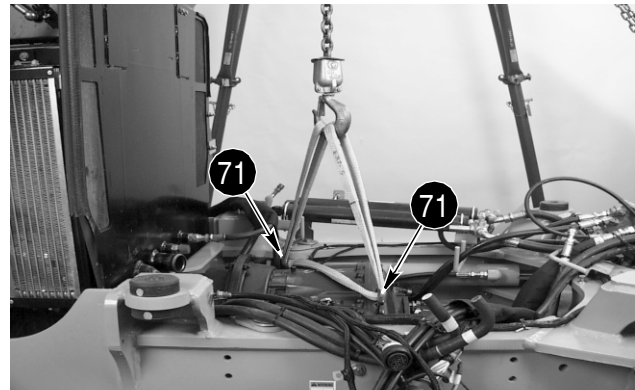
**STEP 42**

BD01D343

Disconnect lifting equipment from transmission lifting eyes (71).

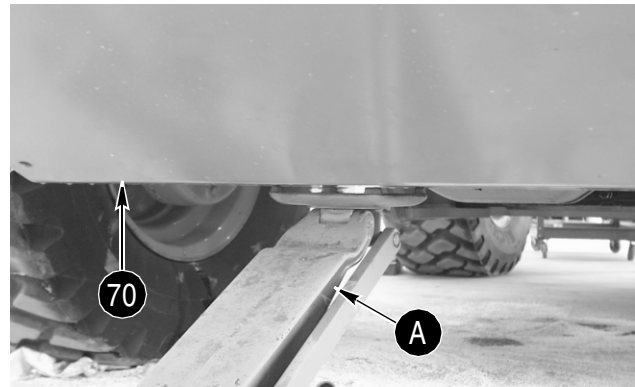
**STEP 43**

BD01D332

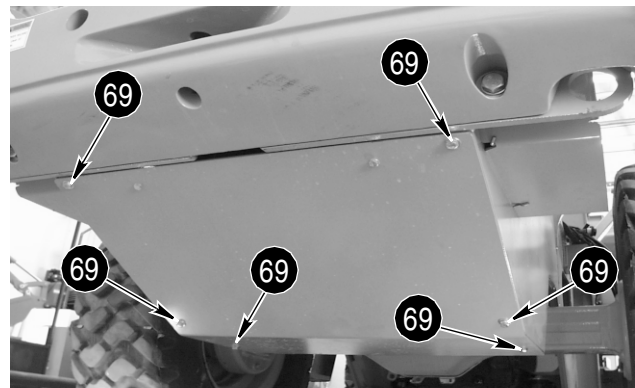

BD01D327

Put fuel tank and plate (70) on hydraulic jack (A) and, with an assistant, move into position beneath loader. Make sure vent hose (67, Step 45) with breather installed is routed up into engine compartment when fuel tank is raised. Raise fuel tank and plate, align mounting holes, and secure using six washers and bolts (69). Lower and remove hydraulic jack (A) from under fuel tank plate.

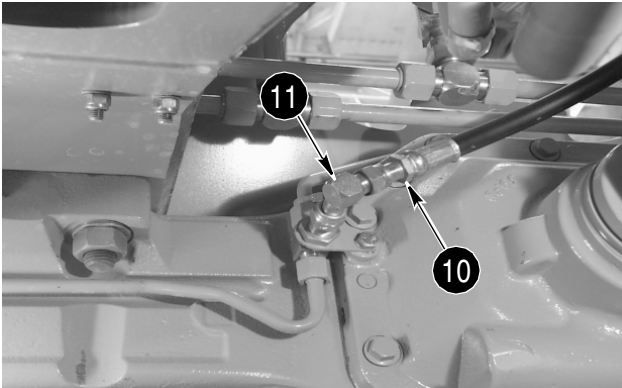
**STEP 90**

BD01D371

Install a new O-ring face seal in fitting (11). Connect brake hose (10) to fitting.

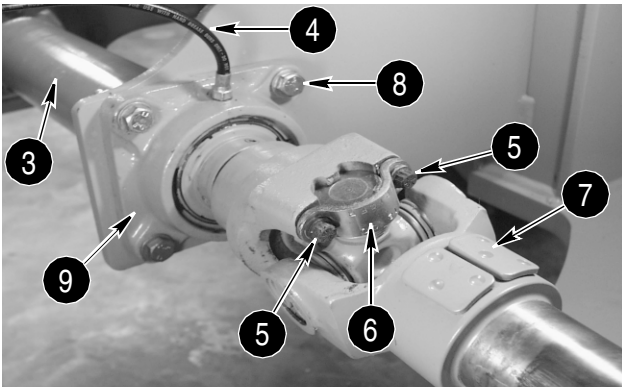
**STEP 91**

BD01D368

Position and support center bearing (9) and front drive shaft (3) and install eight washers and four bolts (8) and nuts. Tighten bolts (8) to a torque of 99 to 128 Nm (73 to 94 lb-ft). Install two straps (6) and four bolts (5). Tighten bolts (5) to a torque of 61 to 81 Nm (45 to 60 lb-ft). Secure lubrication hose (4) to machine using clamp; secure opposite end of hose using nut.

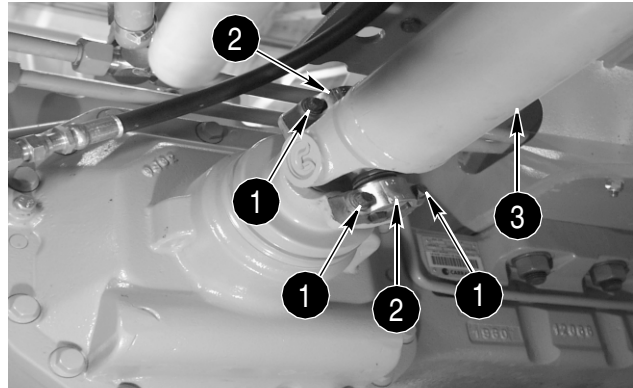
**STEP 92**

BD01D370

Secure drive shaft (3) to front axle using two straps (2) and four bolts (1). Tighten bolts (1) to a torque of 61 to 81 Nm (45 to 60 lb-ft).

**STEP 93**

If necessary, fill axle with gear lubricant specified in Section 1002.

**STEP 94**

Refer to Section 7002 and bleed brakes.

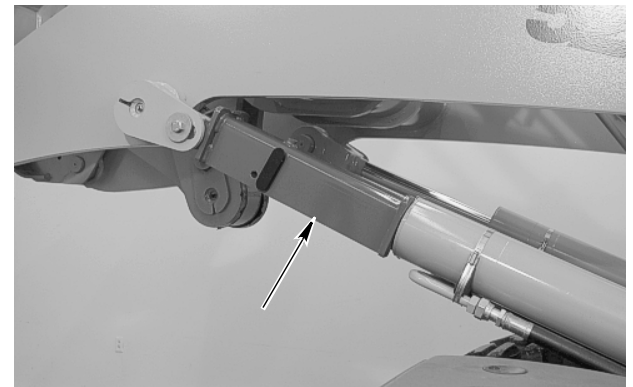
**STEP 95**

BD00M048

Start engine and raise bucket. Have assistant remove safety link. Lower bucket to ground and stop engine.

**STEP 96**

Put articulation lock in OPERATING position.

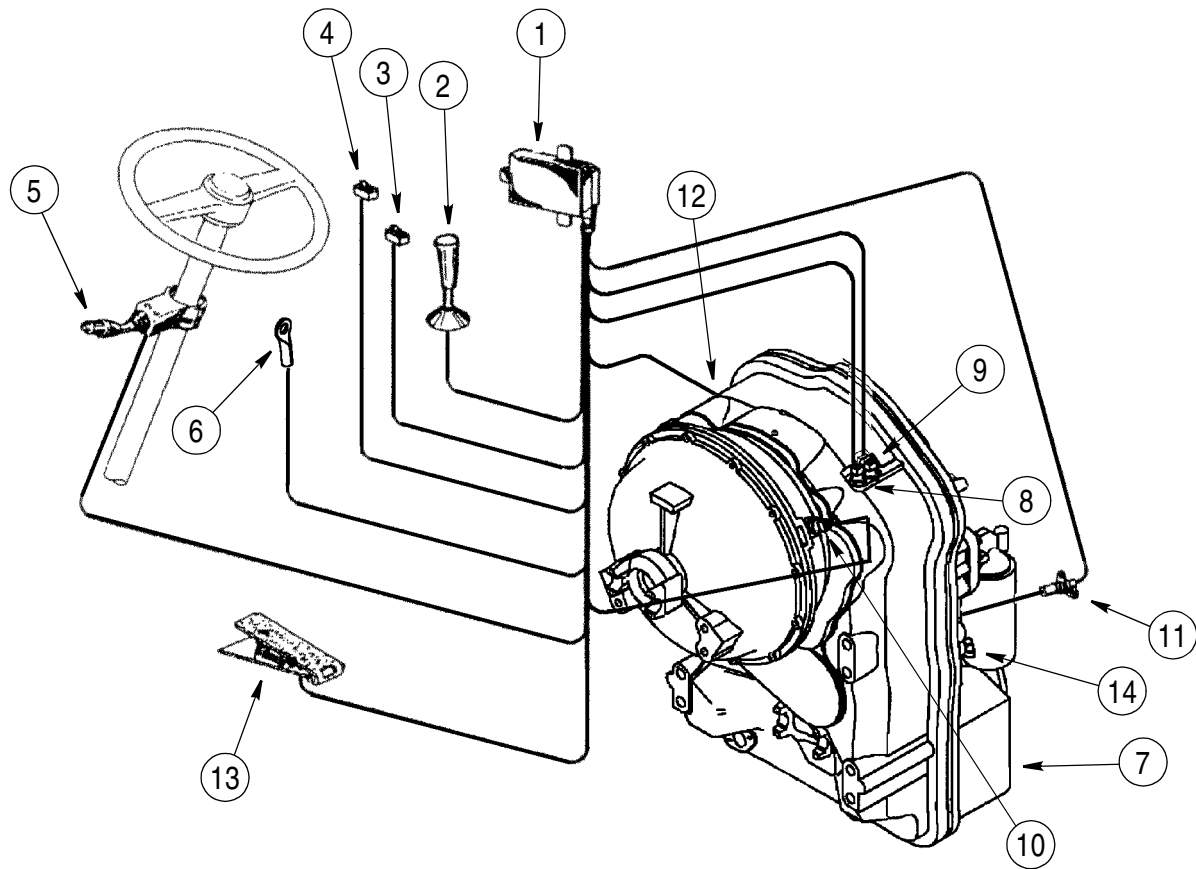

- |  |  |
|--|--|
| 1. TRANSMISSION ELECTRONIC CONTROL MODULE  | 8. INDUCTIVE TRANSMITTER - INTERMEDIATE SPEED SENSOR |
| 2. DOWNSHIFT BUTTON                        | 9. INDUCTIVE TRANSMITTER - TURBINE SPEED SENSOR      |
| 3. DECLUTCH ROCKER SWITCH                  | 10. INDUCTIVE TRANSMITTER - ENGINE SPEED SENSOR      |
| 4. MANUAL/AUTOMATIC ROCKER SWITCH          | 11. HALL SENSOR - OUTPUT SPEED SENSOR                |
| 5. SHIFTER                                 | 12. TRANSMISSION CONTROL VALVE CABLE                 |
| 6. SUPPLY SYSTEM CONNECTIONS B+ AND RETURN | 13. DECLUTCH LIMIT SWITCH                            |
| 7. TRANSMISSION                            | 14. PLUG   |

BS01A190

**FIGURE 1. COMPONENT LOCATIONS SYSTEMS**

## TRANSMISSION PRESSURE TEST POINTS DIAGRAM

No.	IDENTIFICATION/LOCATION	CONNECTION	DESIGNATION ON VALVE BLOCK
<b>Measuring Points for Pressure Oil and Temperature</b>			
51	Before the Converter - Opening Pressure 8 bar (116 psi)	M10x1	H
52	Behind the Converter - Opening Pressure 2.5 bar (36 psi)	M14x1.5	
53	Clutch Forward 16+2 bar (232 + 29 psi)	KV M10x1	B
55	Clutch Reverse 16+2 bar (232 + 29 psi)	KR M10x1	E
56	Clutch 16+2 bar (232 + 29 psi)	K1 M10x1	D
57	Clutch 16+2 bar (232 + 29 psi)	K2 M10x1	A
58	Clutch 16+2 bar (232 + 29 psi)	K3 M10x1	C
60	Clutch 16+2 bar (232 + 29 psi)	K4 M10x1	F
63	Behind the Converter Temperature 100° C, Short Time 120° C	M14x1/5	
65	System Pressure 16+2 bar (232 + 29 psi)	M10x1	K
<b>Measuring Points for Delivery Rates</b>			
15	Connection to the Heat Exchanger	1 5/16" - 12 UNF-2B	
16	Connection from the Heat Exchanger	1 5/16" - 12 UNF-2B	
<b>Inductive Transmitter and Speed Sensor</b>			
21	Inductive Transmitter n Turbine	M18x1.5	
34	Speed Sensor n Output and Speedometer		
47	Inductive Transmitter n Central Gear Train	M18x1.5	
48	Inductive Transmitter n Engine	M18x1.5	
<b>Connections</b>			
49	Plug Connection on the Hydraulic Control Unit		
68	System Pressure	M16x1.5	G
69	Pilot Pressure	M16x1.5	J

**NOTE:** See Figure 10 for Measuring Point, Transmitter, Sensor and Connection locations.

## SPECIAL TORQUES (CONTINUED)

Duct plate	
Screws .....	25 Nm (221 lb-in)
Screw plug .....	30 Nm (265 lb-in)
Hydraulic control unit .....	9.5 Nm (84 lb-in)
Filter	
Filter head screws .....	25 Nm (221 lb-in)
Oil distribution cover screws .....	25 Nm (221 lb-in)
Speed sensor and inductive transmitter	
Speed sensor screw .....	23 Nm (204 lb-in)
Inductive transmitter .....	30 Nm (265 lb-in)
Cover plate .....	23 Nm (204 lb-in)
Screw plug .....	140 Nm (103 lb-ft)

## SPECIFICATIONS

Clutch KV and KR plate clearance .....	2.5 to 2.7 mm (0.098 to 0.106 in)
Clutch K1, K2,K3 plate clearance .....	2.1 to 2.3 mm (0.083 to 0.090 in)
Clutch K4 Plate Clearance .....	1.2 to 1.4 mm (0.047 to 0.055 in)

**NOTE:** *The J I Case Company reserves the right to make improvements in design or changes in specifications at any time without incurring any obligation to install them on units previously sold.*

**STEP 57**

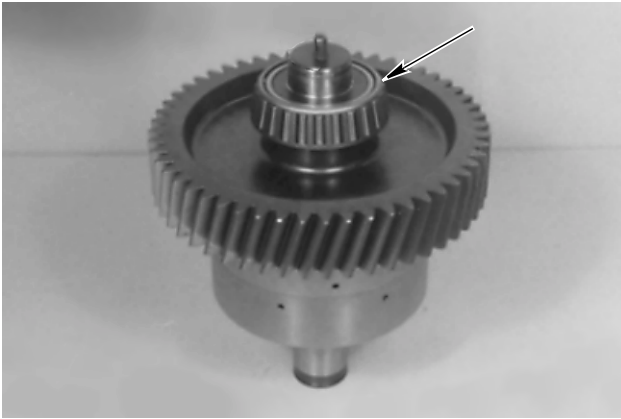

BS00G001

Remove the sealing ring. Remove bearing using bearing puller. Tap assembly until piston drops out of the clutch pack carrier. Then, remove and discard O-rings from piston.

**STEP 58**



BK00D022

Remove the clutch disc carrier from the shaft.

**NOTE:** *The following steps are for the disassembly of the clutch K4.*

**STEP 59**

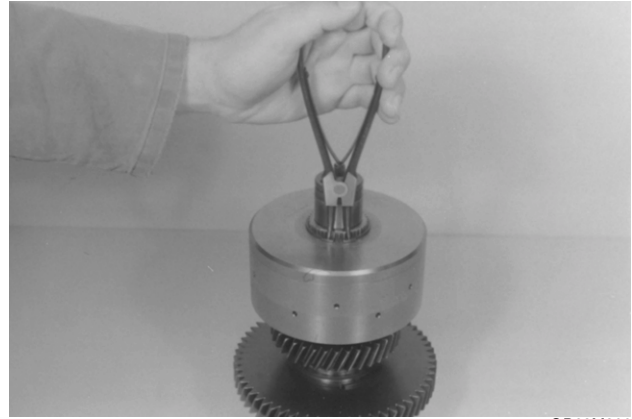

GD98M800

Remove and discard two sealing rings. Pull two bearings from shaft using bearing puller. Remove the snap ring and separate the clutch disc carrier from the shaft.

**STEP 60**

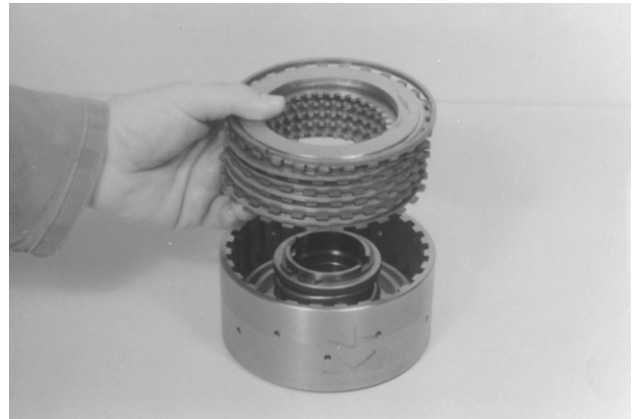

GD98M801

Remove the snap ring and remove the clutch disc pack.

**STEP 61**

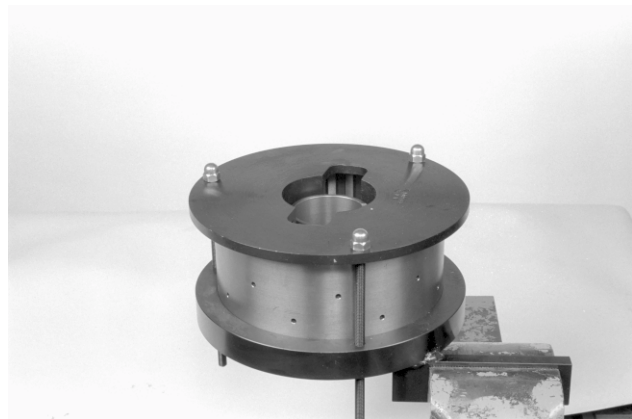

BK00D018

Preload compression spring using CAS2799 clutch pack holder and spring compressor tool.

**STEP 108**

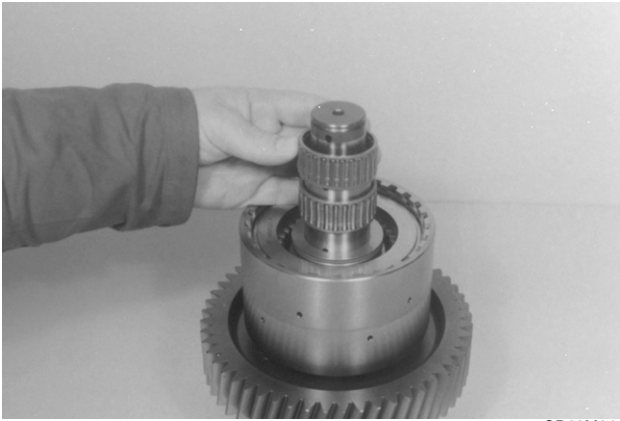

GD98M641

Install both needle bearings.

**STEP 109**

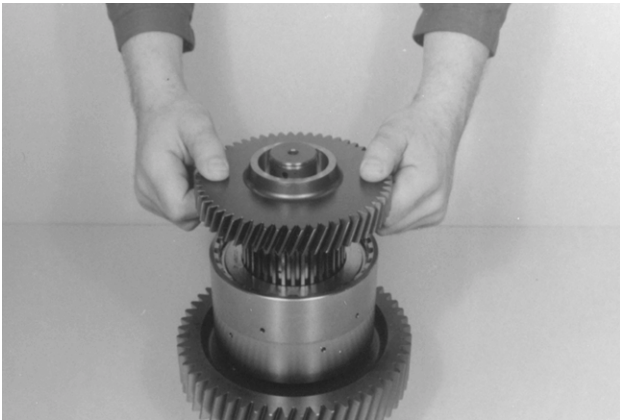

GD98M642

Install idler gear until all inner discs are engaged.

**STEP 110**

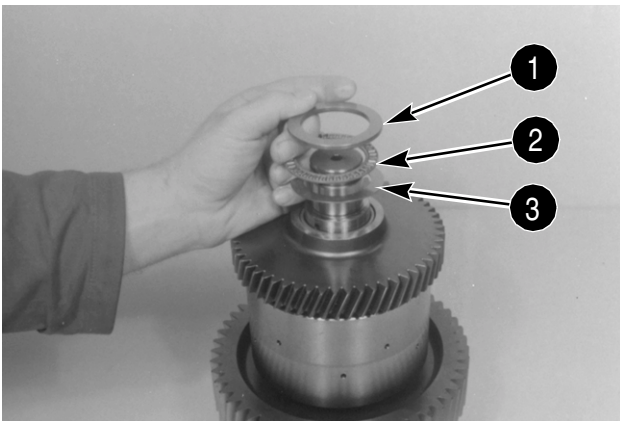

GD98M643

Install the thrust washer (3), thrust bearing (2), and thrust washer (1). Install the thrust washer (1) with the chamfer facing the thrust bearing.

**NOTE:** *Ensure the thrust washer (1) is overlapping with the chaff collar to accommodate all the inner discs.*

**STEP 111**



BK00D024

Heat bearing.

**STEP 112**

 **WARNING:** *Always wear heat protective gloves to prevent burning your hand when handling heated parts.*

SM121A



BK00D025

Place heated bearing on the shaft.

**STEP 113**

Check operation of the clutch using compressed air.

**STEP 165**

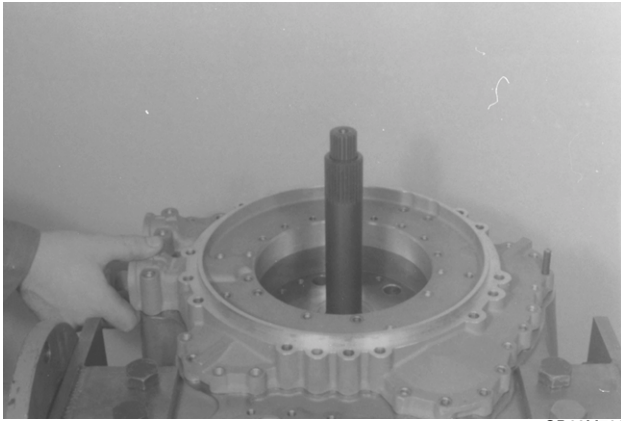

GD98M703

Install the oil feed housing with washers and hex head screws. Screw the hex head screws in only until contact is obtained, do not tighten.

**STEP 166**

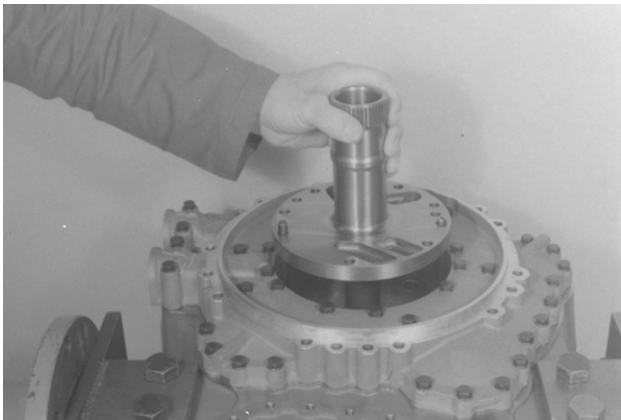

GD98M704

Install the two alignment screws and install the stator shaft.

**STEP 167**

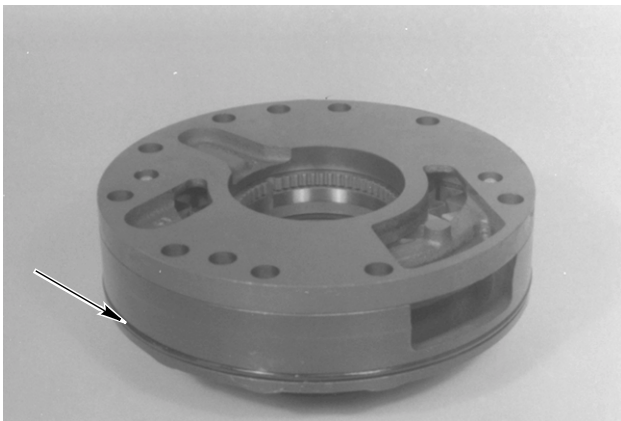

GD98M705

Apply oil and install the O-ring.

**STEP 168**

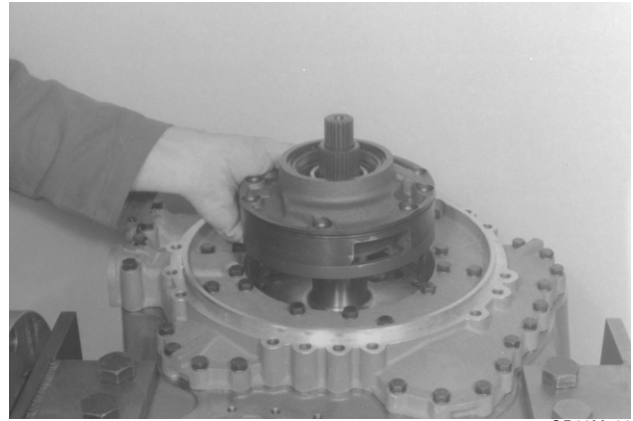

GD98M706

Install transmission pump.

**STEP 169**

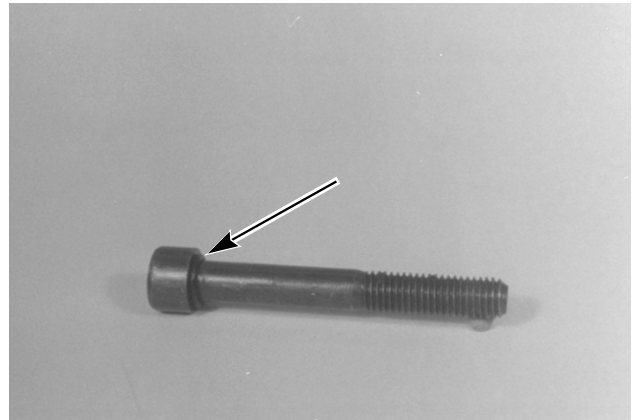

GD98M707

Apply grease to new O-rings. Install the O-rings on the socket head screws.

**STEP 170**

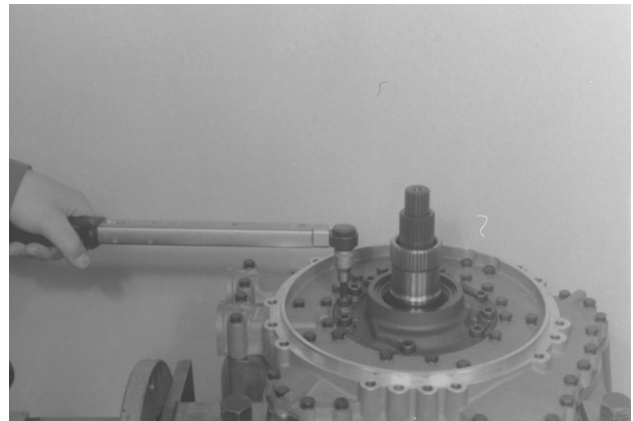

GD98M708

Secure the transmission pump with the socket head screws. Tighten screws to a torque of 46 Nm (407 lb-in).

**STEP 11**

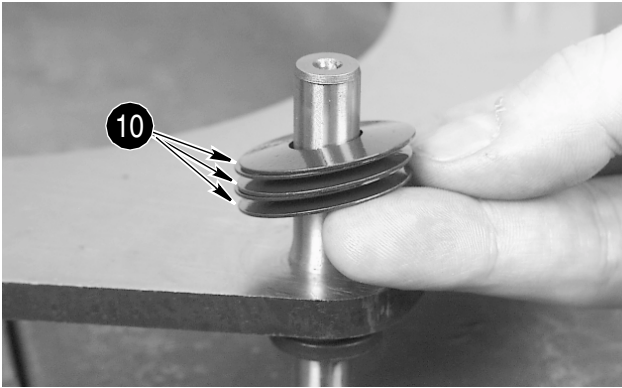

BD01D622

10. BELLEVILLE SPRING

Remove five Belleville springs (10) from each of the four pins. Remove two gripping rings from each pin then remove four pins from separator plate.

**Wheel End**

**STEP 12**



BD01D518

11. O-RING

Remove and discard O-ring (11).

**STEP 13**

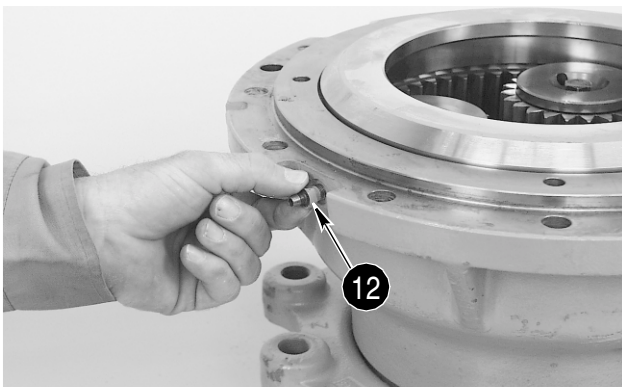

BD01D519

12. BLEEDER VALVE

Remove bleeder valve (12).

**STEP 14**

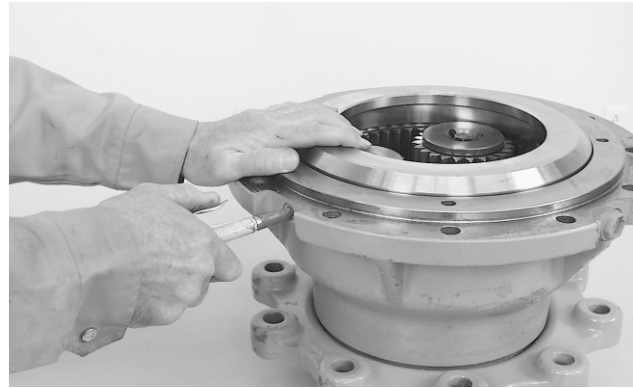

BD01D520

**WEAR EYE PROTECTION WHEN USING COMPRESSED AIR.** Apply compressed air to port from which bleeder valve (12) was removed to free brake piston and carrier.

**STEP 15**

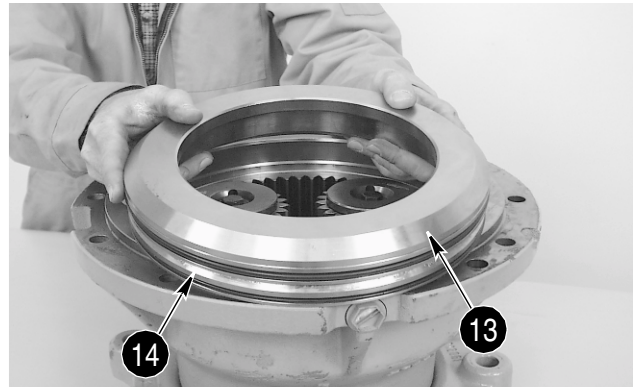

BD01D522

13. BRAKE PISTON 14. BRAKE CARRIER

Remove brake piston (13) and brake carrier (14).

**STEP 16**



BD01D523

15. O-RING  
16. O-RING

Remove brake piston (13) from brake carrier (14). Remove and discard two O-rings (15 and 16).

**STEP 66**

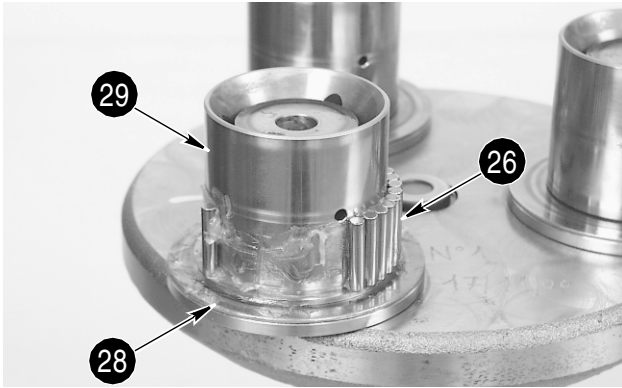

BD01D649

26. NEEDLE BEARINGS    28. WASHER    29. SLEEVE  
Install washer (28). Apply petroleum jelly to bottom portion of sleeve (29). Install 39 needle bearings (26) on periphery of sleeve.

**STEP 67**



BD01D650

27. WASHER  
Install washer (27).

**STEP 68**

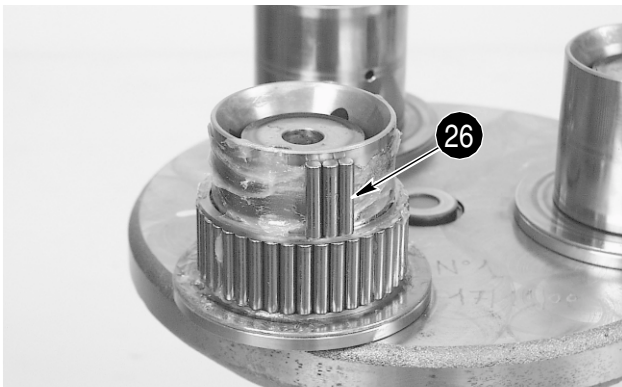

BD01D652

26. NEEDLE BEARING  
Apply petroleum jelly to upper portion of sleeve (29). Install 39 needle bearings (26) on periphery of sleeve.

**STEP 69**



BD01D653

24. WASHER  
Install washer (24).

**STEP 70**

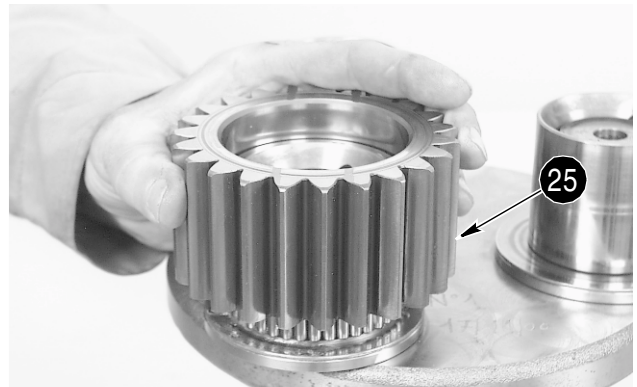

BD01D654

25. GEAR  
Install gear (25). Do Steps 66 through 70 to install the remaining washers, roller bearings, and gears.

**STEP 71**

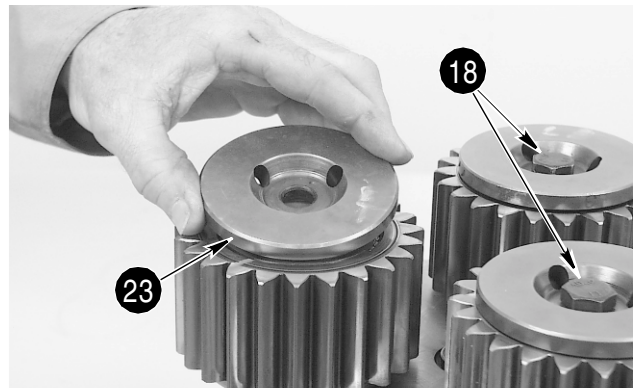

BD01D631

18. RETAINER    23. BOLT  
Install retainers (23). Apply Loctite 270 to threads of three bolts (18) and install bolts.

**STEP 120**

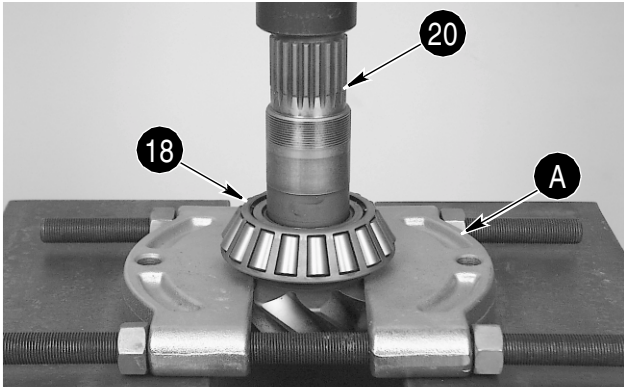

BD01D564

18. INNER BEARING    20. PINION SHAFT    A. COLLAR  
 Put pinion shaft (20) and inner bearing (18) in hydraulic press. Install collar (A). Put a support under pinion shaft to prevent it from falling on floor. Press pinion shaft from bearing.

**STEP 121**

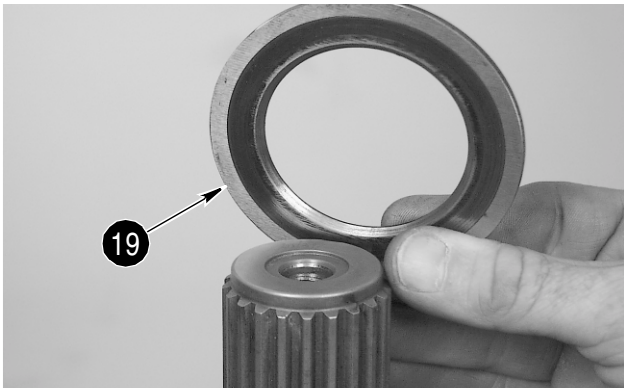

BD01D565

19. SHIM

Remove shim (19) from pinion shaft.

**STEP 122**

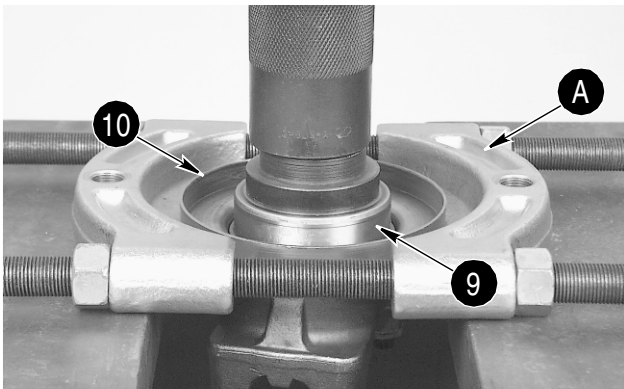

BD01D673

9. AXLE FLANGE    A. COLLAR  
 10. COVER

To remove axle flange (9) from cover (10), install collar (A) as shown and press flange from cover.

**STEP 123**

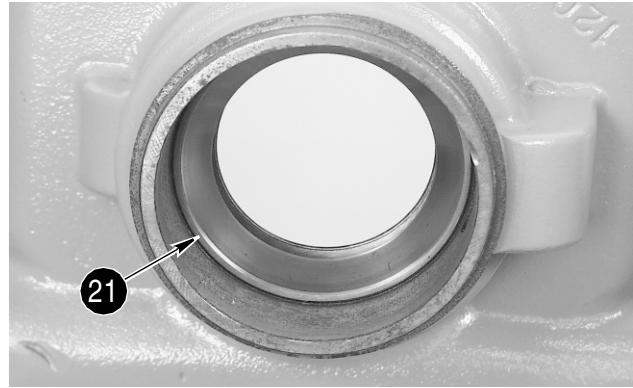

BD01D567

21. OUTER BEARING CUP

If outer bearing cup (21) requires replacement, use a slide hammer and suitable puller to remove.

**STEP 124**



BD01D568

22. INNER BEARING CUP

If inner bearing cup (22) requires replacement, use a slide hammer and suitable puller to remove.

**STEP 170**

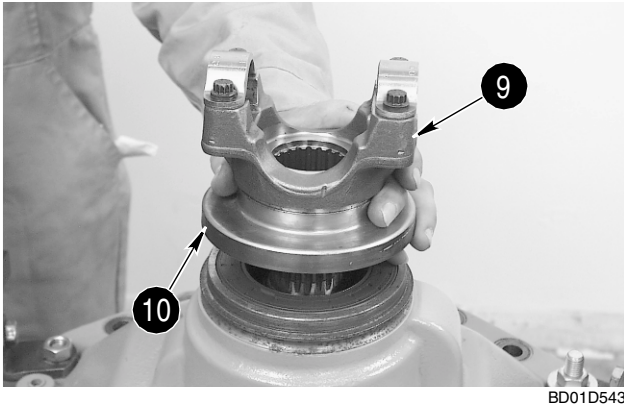

9. AXLE FLANGE 10. COVER

Install cover (10) and axle flange (9).

**STEP 171**

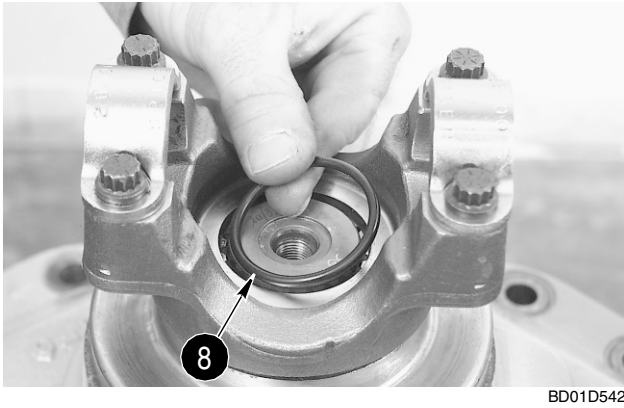

8. O-RING

Install new O-ring (8).

**STEP 172**

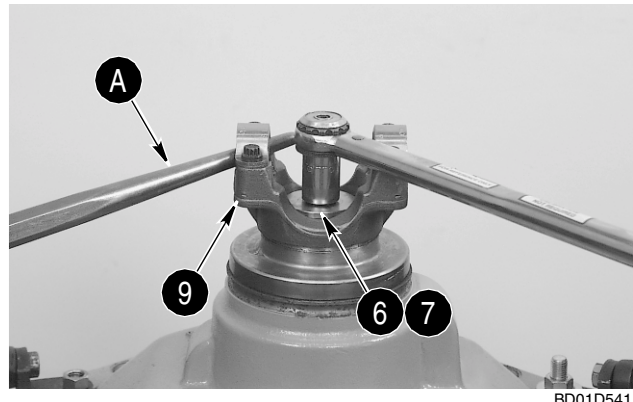

6. BOLT 9. AXLE FLANGE  
7. WASHER A. PRYBAR

Reposition differential carrier. Apply Loctite 270 to threads of bolt (6). Install washer (7) and bolt. Using prybar (A) to prevent axle flange from turning, tighten bolt to a torque of 139 Nm (102.5 lb-ft).

**Installation**

- 1. BOLT
- 2. DIFFERENTIAL CARRIER
- 3. LOCKING PIN

**FRONT AXLE**

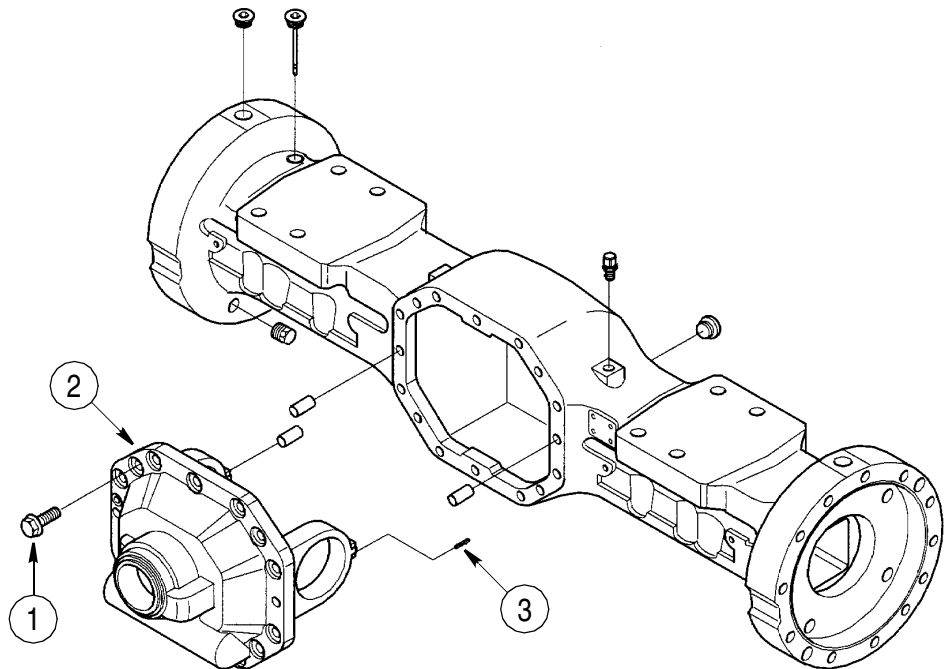

BS01M168

# Assembly - Open Differential

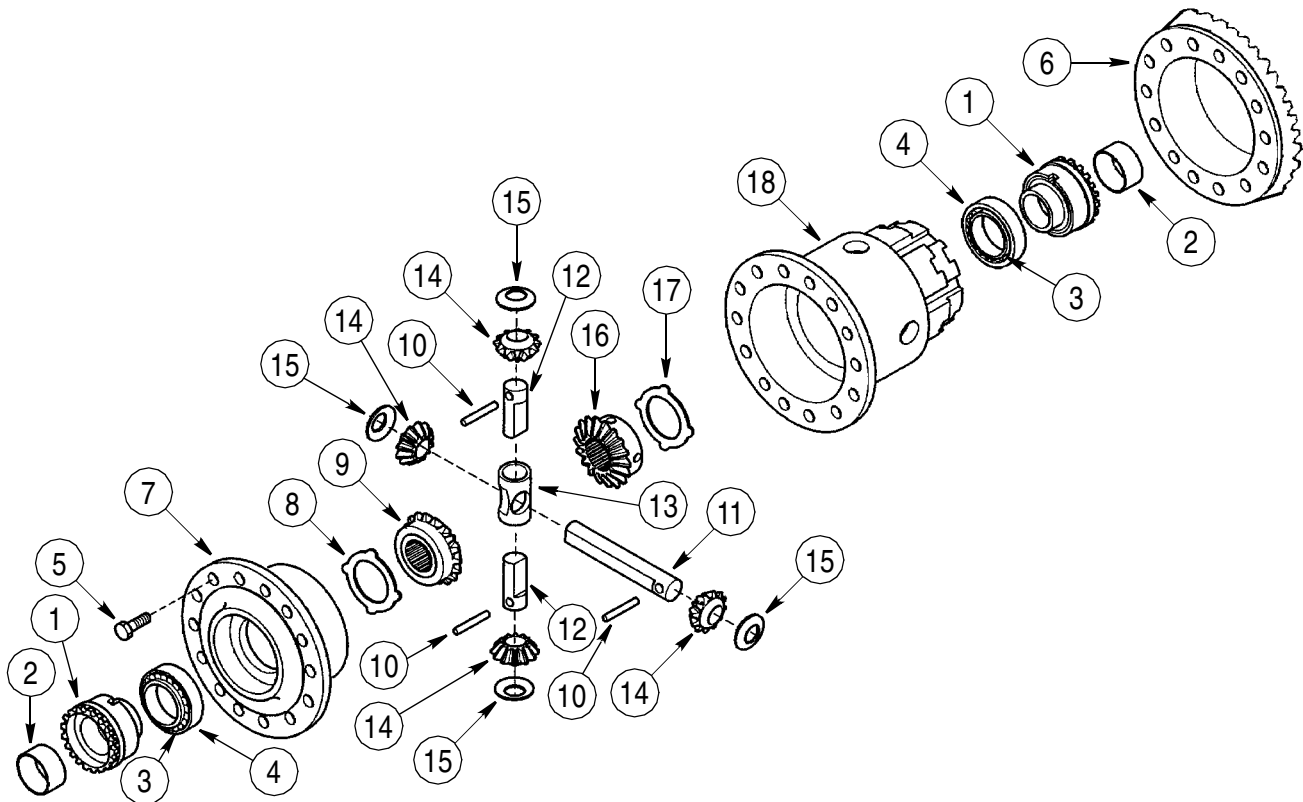

BS01M177

- |                |                  |                     |                   |
|----------------|------------------|---------------------|-------------------|
| 1. CARRIER     | 6. RING GEAR     | 11. LONG SHAFT      | 16. SIDE GEAR     |
| 2. BUSHING     | 7. HOUSING COVER | 12. SHORT SHAFT     | 17. COUNTER PLATE |
| 3. BEARING     | 8. COUNTER PLATE | 13. SHAFT RETAINER' | 18. HOUSING       |
| 4. BEARING CUP | 9. SIDE GEAR     | 14. PINION GEAR     |                   |
| 5. BOLT        | 10. PIN          | 15. THRUST WASHER   |                   |

## STEP 217

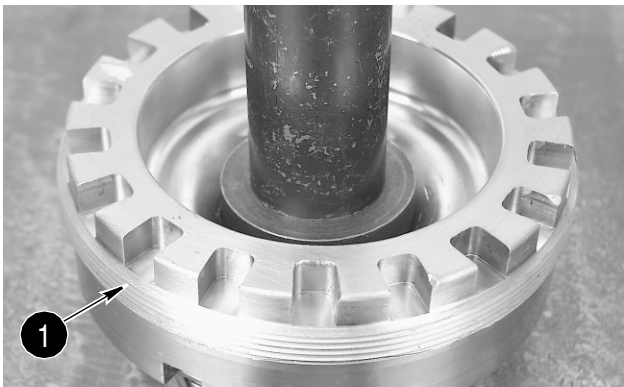

BD01D610

1. CARRIER

If bushing (2) was removed for replacement, press new bushing into carrier (1) using proper size pusher and sleeve. Press bushing into carrier until it stops moving.

## STEP 218

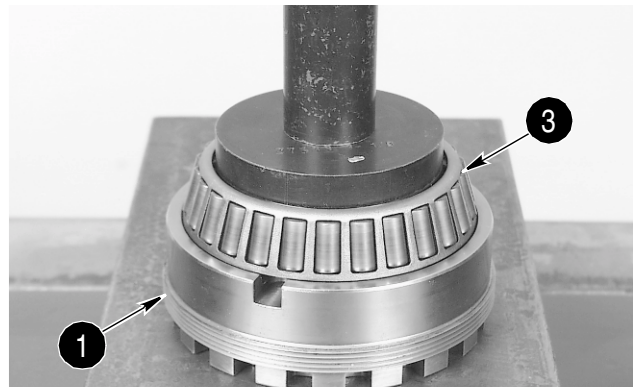

BD01D609

1. CARRIER 3. BEARING

If bearing (3) was removed for replacement, press new bearing onto carrier (1) until bearing is flush against shoulder.

## TABLE OF CONTENTS

SPECIFICATIONS .....	3
SPECIAL TORQUES .....	3
SPECIAL TOOLS .....	3
GEAR TOOTH CONTACT PATTERNS .....	4
LUBRICATION .....	6
WEAR MEASUREMENT ON MULTI-DISC BRAKE .....	6
WHEEL END AND BRAKE .....	7
Disassembly .....	7
Cleaning and Inspection .....	13
Assembly .....	13
BRAKE HYDRAULICS LEAKAGE TEST .....	23
High Pressure Test .....	23
Low Pressure Test .....	23
DIFFERENTIAL CARRIER DISASSEMBLY .....	24
DIFFERENTIAL DISASSEMBLY .....	27
DRIVE PINION DISASSEMBLY .....	28
REAR AXLE PIVOT PIN BUSHINGS .....	29
BRAKE TUBES REMOVAL .....	30
BRAKE TUBES INSTALLATION .....	31
DIFFERENTIAL CARRIER ASSEMBLY .....	33
Determine Shim Thickness for Correct Tooth Contact Pattern .....	33
Install Drive Pinion .....	34
Drive Pinion Bearing Rolling Torque Adjustment .....	35
DIFFERENTIAL ASSEMBLY .....	37
Open Differential Assembly .....	37
Limited Slip Differential Assembly .....	38
Adjust Backlash and Bearing Preload .....	41

**STEP 29**



BD02D026

Using the CAS2850 brake housing puller bridge and 8073 step plate, pull the brake housing from the wheel end shaft and remove the inner bearing.

**STEP 30**



BD02D027

Use acceptable lifting equipment and lift the brake housing from the wheel end shaft.

**STEP 31**



BD02D028

If replacement of bearing cups is necessary, drive both bearing cups out of the brake housing.

**STEP 32**



BD02D029

Remove the face seal from the brake housing.

**STEP 33**

Using a puller, remove the outer bearing from the wheel end shaft.

**STEP 34**



BD02D030

Remove and discard the face seal metal ring from the wheel end shaft.

**STEP 78**



1. O-RING

BD00M303

Install a new O-ring on the wheel end cover.

**STEP 79**

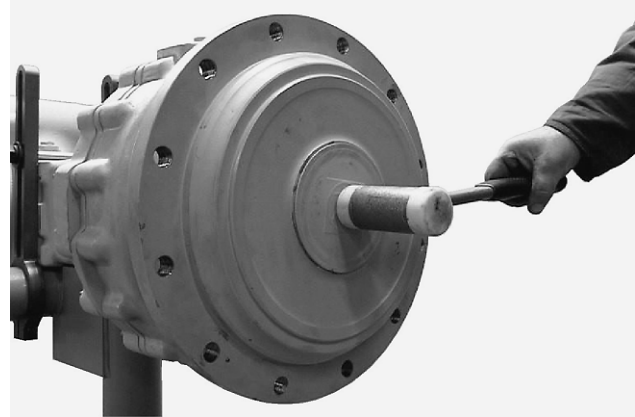

BD02D153

Install the cover into the wheel end.

**STEP 124**

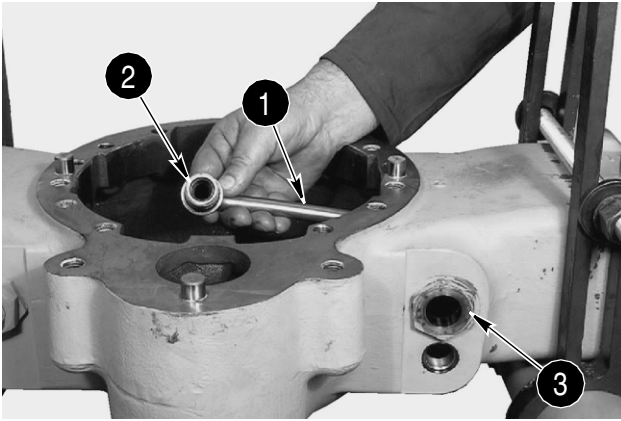

BD02D118

- 1. BRAKE TUBE
- 2. FITTING
- 3. CONNECTOR

Install the brake tube (1) in the axle housing, inserting the fitting (2) through the connector (3).

**STEP 125**

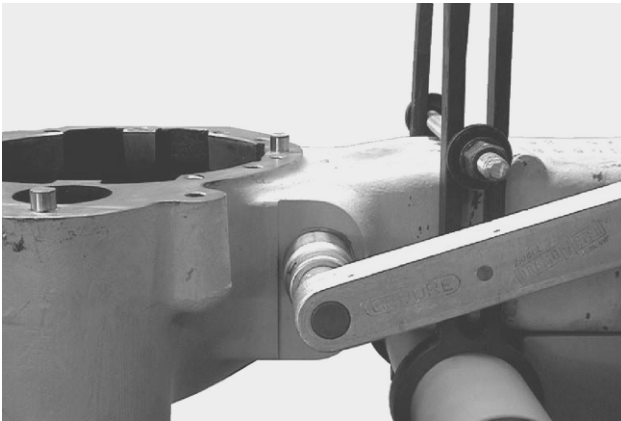

BD02D119

Install the nut to secure the brake tube fitting. Tighten the nut to a torque of 140 Nm (103 lb-ft).

**STEP 126**

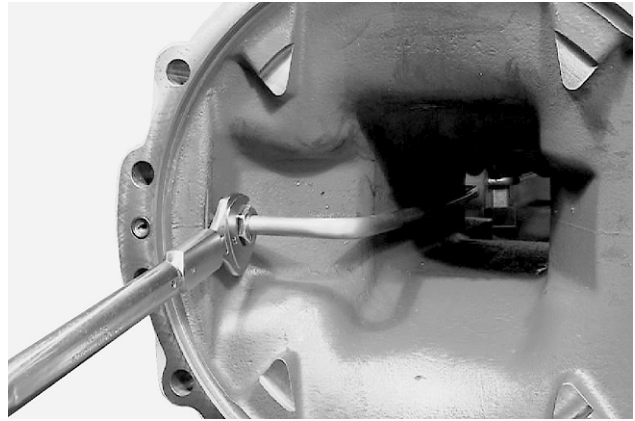

BD02D120

Connect fitting on opposite end of brake tube to fitting installed in wheel end. Tighten brake tube fitting to a torque of 80 Nm (60 lb-ft).

**NOTE:** Do Steps 119 to 126 on other wheel end.

**STEP 127**

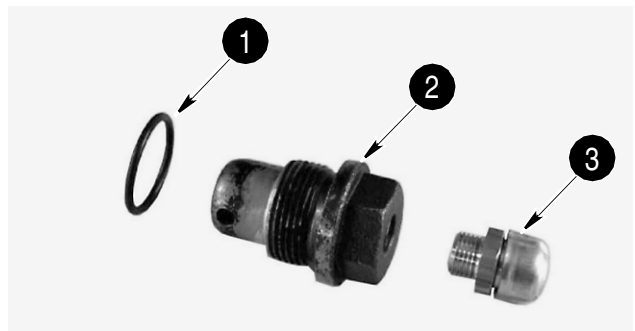

BD00M347

- 1. O-RING
- 2. PLUG
- 3. BREATHER

Remove and discard O-ring (1) from plug (2) and install a new O-ring. Install breather (3) in plug.

**STEP 128**



BD02D121

Install the plug in axle housing. Tighten plug to a torque of 140 Nm (103 lb-ft)

### STEP 177

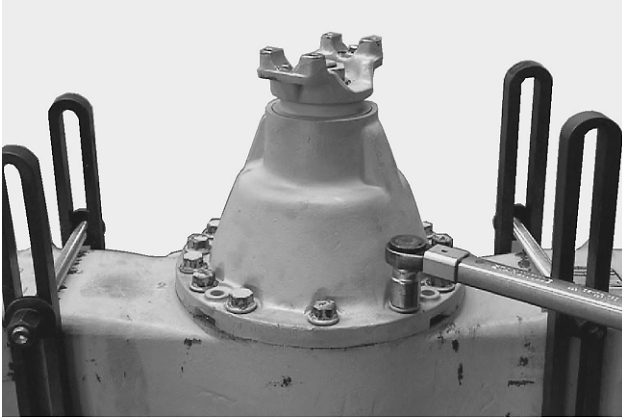

BD02D151

Using new bolts, secure the differential carrier to the axle housing. Tighten bolts to a torque of 390 Nm (288 lb-ft).

### STEP 178



BD02D050

Install the stub shaft into the spline of the differential bevel gear.

### STEP 179

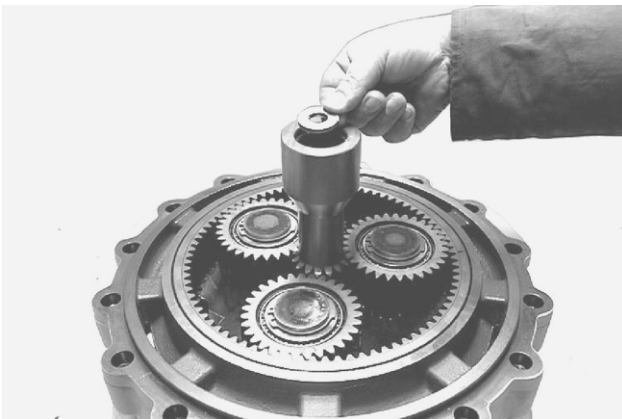

BD02D011

Install the thrust washer removed at disassembly. Use grease to keep it in the sun gear.

### STEP 180

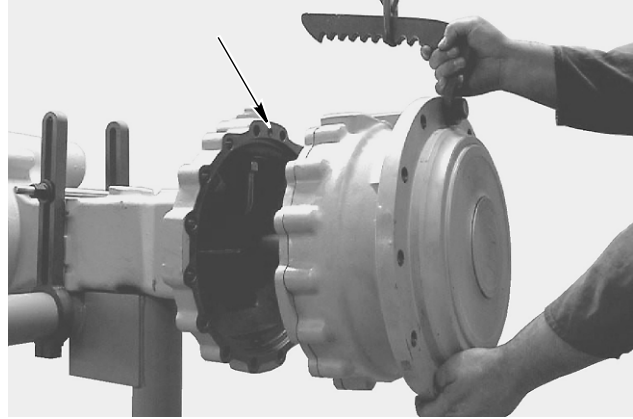

BD02D054

Apply grease to a new O-ring and install O-ring in brake port. Position the wheel end on the axle housing.

### STEP 181

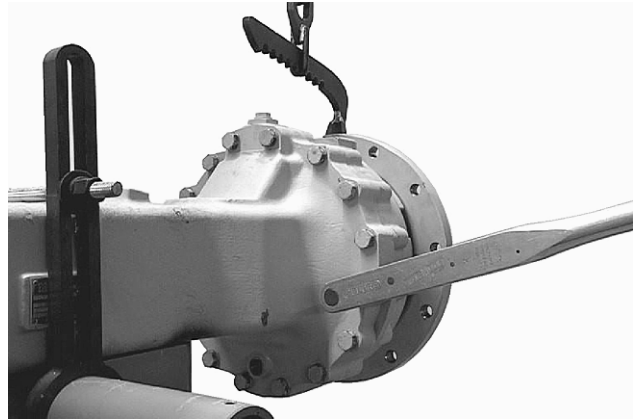

BD02D154

Install the washers and bolts on the wheel end. Tighten the bolts to a torque of 390 Nm (288 lb-ft)

**NOTE:** Repeat Steps 178 through 181 for the other wheel end.

**NOTE:** Refer to Section 1002 of this service manual for proper lubricant.

## ENGINE DRIVE SHAFT

### Removal

**NOTE:** It may be necessary to remove the fuel tank to gain access to the bolts and straps that fasten the engine drive shaft to the transmission. Step 47 to Step 54 show how to remove the fuel tank.

#### STEP 47

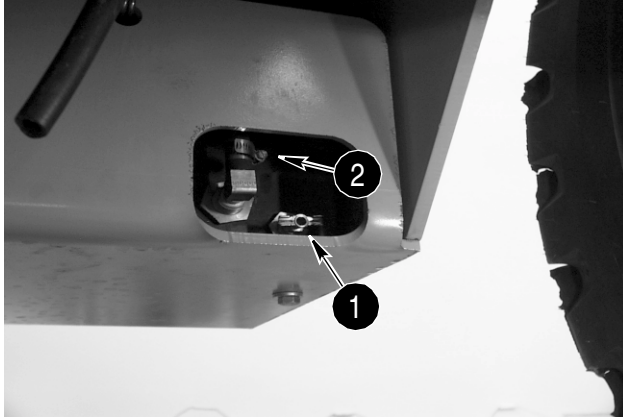

BD01D325

1. DRAIN VALVE      2. HOSE

Connect a drain hose to the drain valve (1) on the fuel tank and drain the tank.

#### STEP 48

Loosen the hose clamp and disconnect the return hose (2) from the fuel tank. Plug the hose and cap the fitting. Put an identification tag on the hose for reference during installation. Refer to the above photo.

#### STEP 49

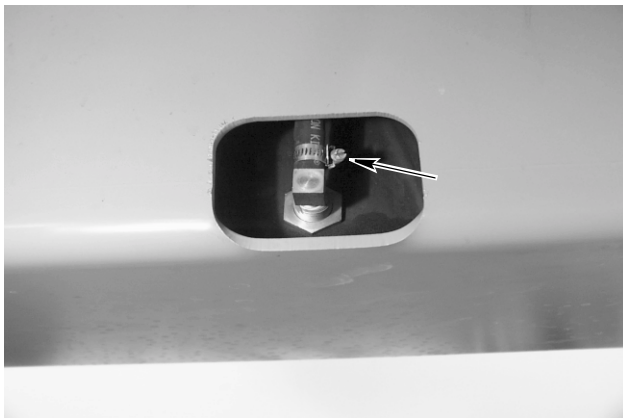

BD01D326

Loosen the hose clamp and disconnect the fuel supply hose from the fuel tank. Plug the hose and cap the fitting. Put an identification tag on the hose for reference during installation.

#### STEP 50



BD01D330

Tag and disconnect the two wires from the fuel level indicator.

#### STEP 51



BD01D328

Loosen and remove the bolt and nut that fasten the breather to the machine.

#### STEP 52



BD01D332

Place a jack under the center of the fuel tank plate.

## TABLE OF CONTENTS

SPECIAL TOOLS ..... 2  
 SPECIAL TORQUES ..... 2  
 DISASSEMBLY ..... 3  
 INSPECTION ..... 7  
 ASSEMBLY ..... 9

### SPECIAL TOOLS

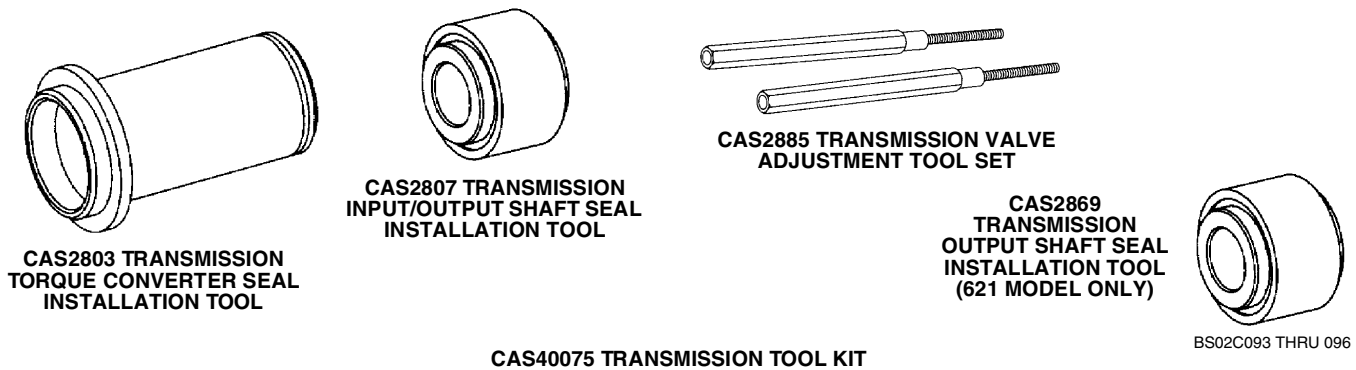

### SPECIAL TORQUES

Screws Securing End Housings to Valve Housing ..... 5.5 Nm (48 lb-in)  
 Screws Securing Pressure Regulator Locating Plates ..... 5.5 Nm (48 lb-in)  
 Screws Securing Covers to End Housings ..... 5.5 Nm (48 lb-in)  
 Valve Housing Plugs ..... 6 Nm (53 lb-in)  
 Screws Securing Distribution Plate to Valve Housing ..... 9.5 Nm (84 lb-in)

### STEP 43

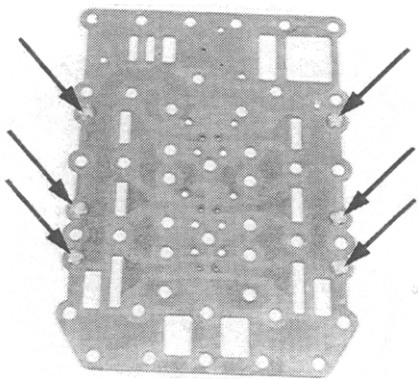

BS02C129

Install six filter screens (6) flush in bores of valve plate (4). Screens must be facing upward toward distribution plate (2). Make sure marks made in Step 1 are aligned.

### STEP 44

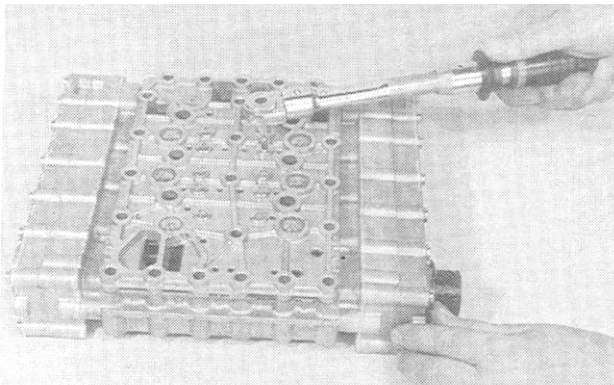

BS02C130

Install housing gasket (3) then distribution plate (2). Make sure marks made in Step 1 are aligned. Install 18 screws (1) and tighten evenly to a torque of 9.5 Nm (84 lb-in).

### STEP 45

Refer to Section 6003 and install transmission control valve.

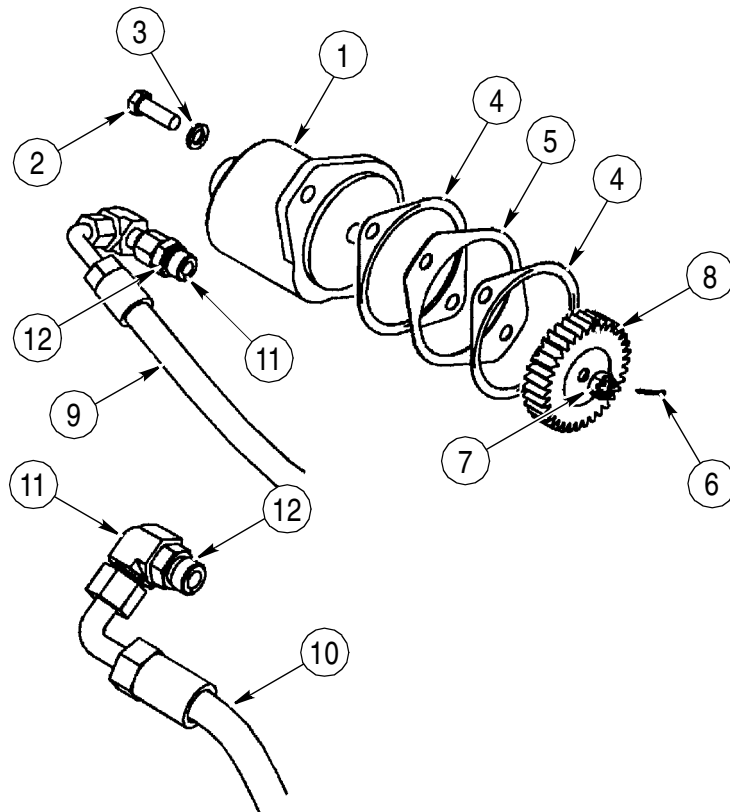

- |               |                  |
|---------------|------------------|
| 1. BRAKE PUMP | 7. NUT           |
| 2. BOLT       | 8. GEAR          |
| 3. WASHER     | 9. PRESSURE HOSE |
| 4. GASKET     | 10. SUCTION HOSE |
| 5. SPACER     | 11. ELBOW        |
| 6. COTTER PIN | 12. O-RING       |

**BRAKE PUMP ILLUSTRATION - P.I.N. JEE0135501 AND ABOVE**

BS02K143

## CHECKING THE BRAKE SYSTEM

1. Check the level of the hydraulic fluid in the reservoir, add as needed.

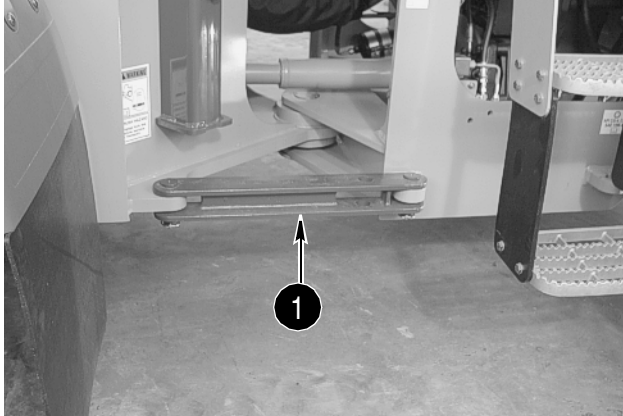

BD00M030

1. ARTICULATION LOCK

2. Install the articulation lock (1) before doing this test.
  3. Remove the left side cab skirt to gain access to the brake accumulators (5 and 6). Refer to the illustration below or on page 10.
  4. Pump the brake pedal (8) until there is no hydraulic pressure in the brake system (approximately 20 pumps).
  5. Connect two 207 bar (3000 psi) pressure gauges to the test ports (3 and 4).
  6. Start the engine and let idle until both the front and rear accumulators (5 and 6) are fully charged. The accumulators are fully charged at 190 to 196 bar (2755 to 2842 psi).
  7. Stop the engine.
  8. Push the brake pedal (8) down slowly, allowing for full piston actuation.
- NOTE:** Depress the brake pedal at the rate of three strokes per minute.
9. Continue pressing the brake pedal (8) down. The low brake pressure light should activate when the pressure reaches 110 to 124 bar (1600 to 1800 psi). After the low brake pressure light activates, press the brake pedal eight more times.
  10. Record the readings on the pressure gauges. The pressure gauges should read at or above 52 to 58 bar (750 to 850 psi).
  11. If the pressures are at or above 52 to 58 bar (750 to 850 psi), the test is complete.
  12. If the pressures are not within the required specifications, then the brake system must be bled.
  13. After bleeding the brake system, perform the brake system check again.

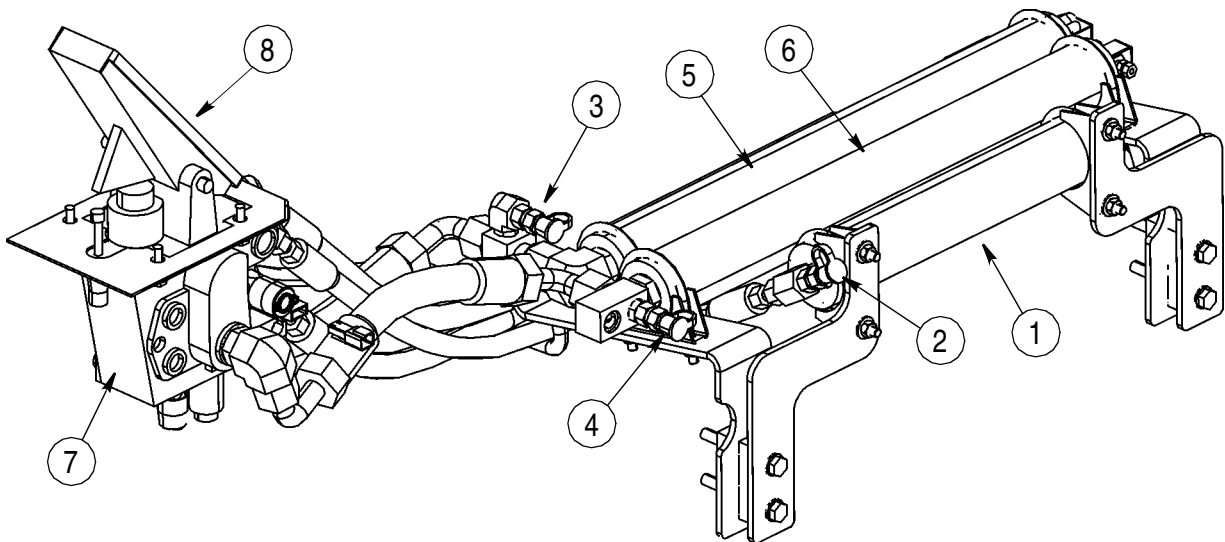

BC01B050

- |  |   |
|--|---|
| 1. PARKING BRAKE ACCUMULATOR           | 5. FRONT BRAKE ACCUMULATOR              |
| 2. PARKING BRAKE ACCUMULATOR TEST PORT | 6. REAR BRAKE ACCUMULATOR               |
| 3. FRONT BRAKE ACCUMULATOR TEST PORT   | 7. BRAKE AND ACCUMULATOR CHARGING VALVE |
| 4. REAR BRAKE ACCUMULATOR TEST PORT    | 8. BRAKE PEDAL                          |

### BRAKE SYSTEM COMPONENTS - P.I.N. JEE0135500 AND BELOW

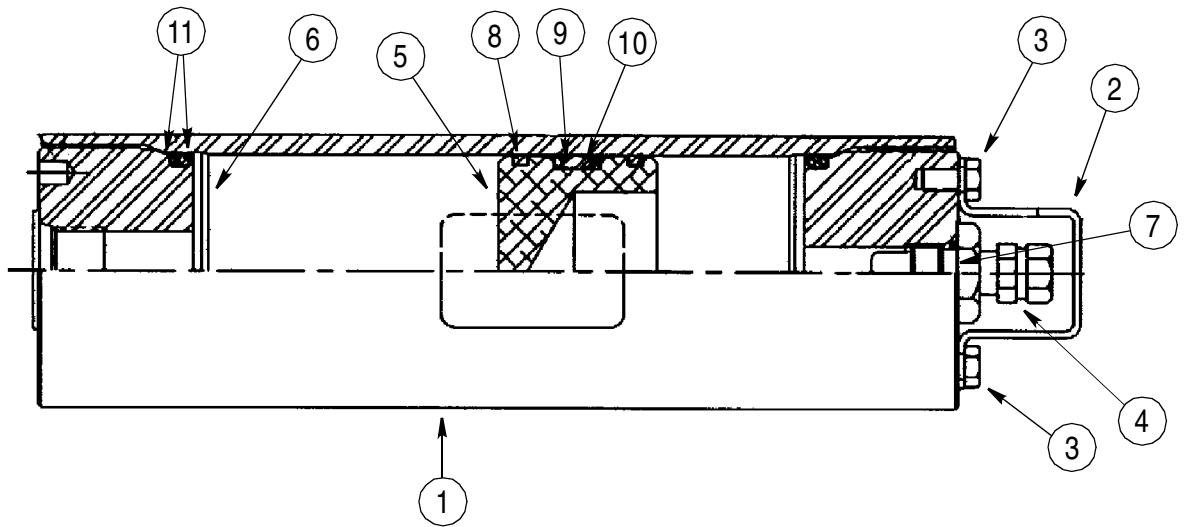

- |          |                   |                |               |
|----------|-------------------|----------------|---------------|
| 1. BODY  | 4. PRESSURE VALVE | 7. O-RING      | 10. O-RING    |
| 2. GUARD | 5. PISTON         | 8. WEAR RING   | 11. SEALS (2) |
| 3. SCREW | 6. GLAND          | 9. BACKUP RING |               |

BS01B224

**PARKING BRAKE ACCUMULATOR - P.I.N. JEE0135500 AND BELOW**

# SECTION INDEX

## HYDRAULICS

<b>Section Title</b>	<b>Section Number</b>
Removal and Installation of Hydraulic Components . . . . .	8001
Hydraulic Specifications, Troubleshooting, and Pressure Checks . . . . .	8002
Cleaning the Hydraulic System . . . . .	8003
Loader Control Valve . . . . .	8005
Cylinders . . . . .	8006
Coupler Solenoid Locking Valve . . . . .	8007
Pilot Pressure Accumulator and Ride Control Accumulator . . . . .	8013
Ride Control Valve . . . . .	8014

### STEP 40



BD01D720

Loosen and remove the two screws and washers holding the hydraulic control tower cover. Remove the cover.

### STEP 41

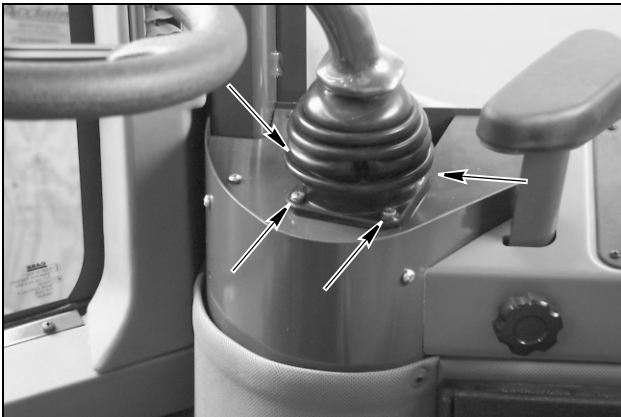

BD01D722

Loosen and remove the four screws that fasten the remote control valve to the hydraulic control tower.

### STEP 42

Remove the remote control valve from the hydraulic control tower.

## Installation

### STEP 43

Install new O-rings on the adapters for the remote control valve.

### STEP 44

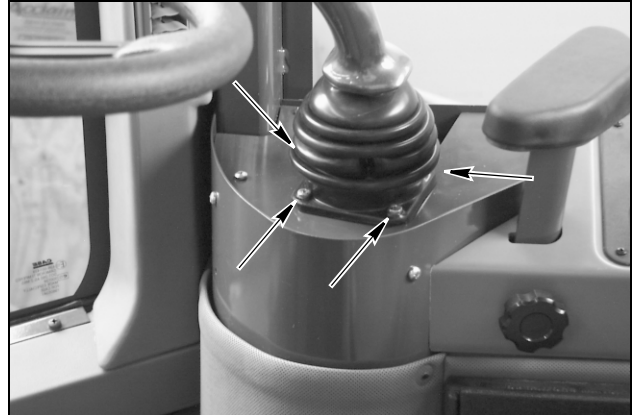

BD01D722

Install the remote control valve and screws in the hydraulic control tower and tighten the screws.

### STEP 45

Connect the electrical connectors for the remote control valve.

### STEP 46



BD01D720

Install the cover over the remote control valve and install the two screws and washers.

### STEP 47

Remove the plugs from the hoses and the caps from the fittings and connect the hydraulic hoses to the fittings according to the identification tags. (Refer to illustrations on pages 12 through 14 as necessary.)

### STEP 48

Fill the hydraulic reservoir. See Section 1002 for the correct hydraulic oil.

### STEP 88



Loosen and remove the bolt, washer and spacer that hold the pivot pin at the closed end of the lift cylinder.

### STEP 89



Remove the pivot pin from the closed end of the lift cylinder.

### STEP 90

Remove the lift cylinder from the machine

## Installation

### STEP 91

Apply antiseize compound to the bores in the front frame and the yoke on the piston rod.

### STEP 92



Use a proper lifting device and position the lift cylinder on the machine.

### STEP 93



Align the closed end of the lift cylinder with the front frame and install the pivot pin.

**STEP 159**

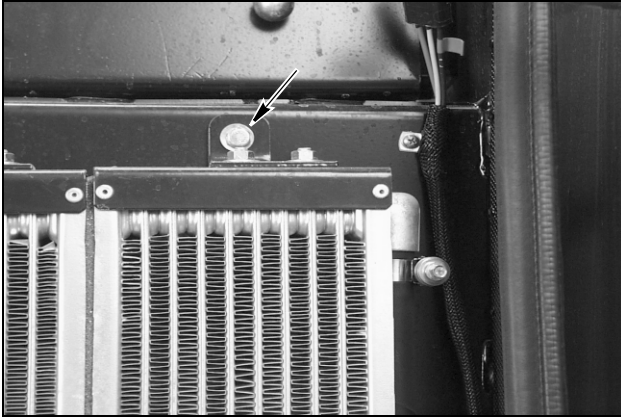

BD01D234

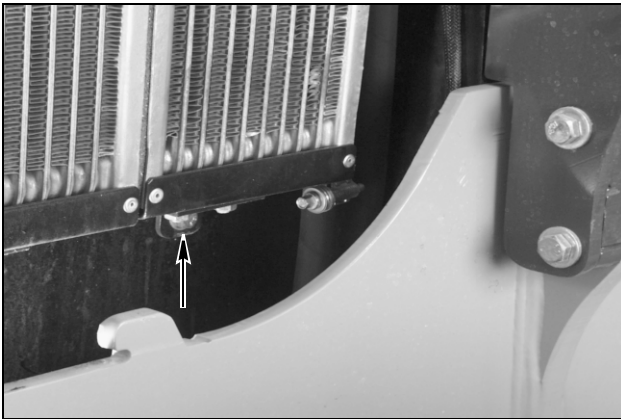

BD01D231

Loosen and remove the bolts and washers that fasten the oil cooler to the cooling frame.

**STEP 160**

Remove the oil cooler from the machine.

**Installation**

**STEP 161**

Place the oil cooler in position in the cooling frame.

**STEP 162**

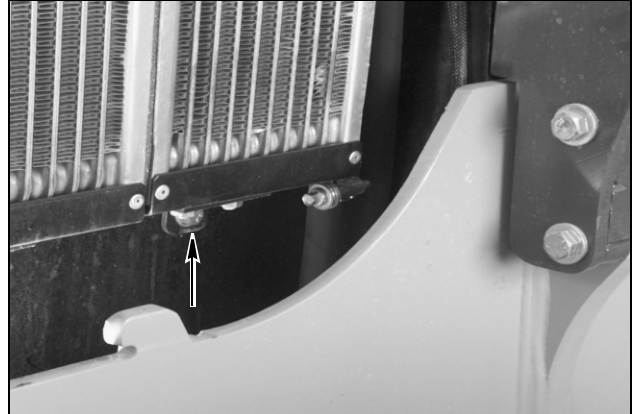

BD01D231

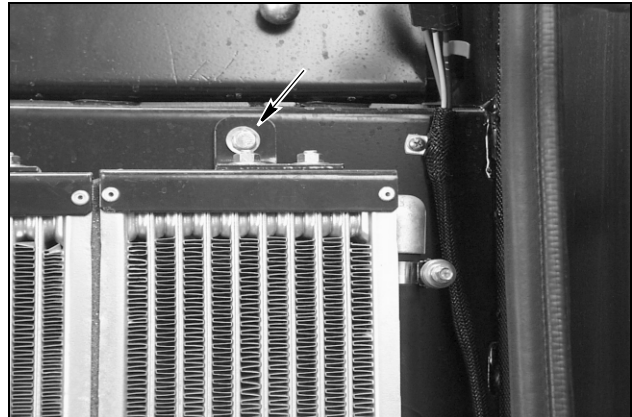

BD01D234

Install the bolts and washers that fasten the oil cooler to the cooling frame

**STEP 163**



BD01D231

Connect the hose to the bottom of the oil cooler.

**STEP 230**

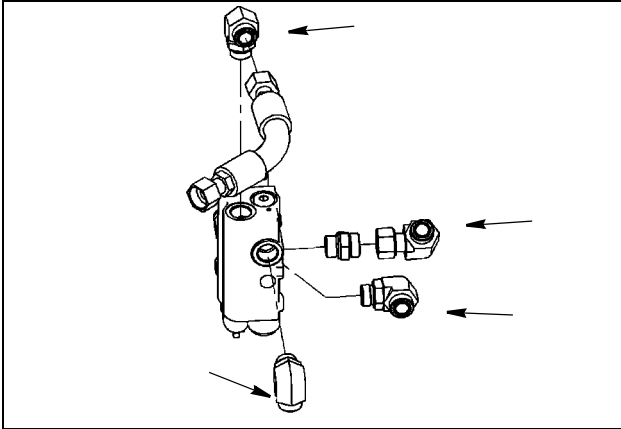

BC05B017

Connect the hoses to the ride control valve.

**STEP 231**

Connect the electrical connector to the ride control valve.

**STEP 232**

Turn off the vacuum pump and disconnect from the hydraulic reservoir.

**STEP 233**

Place the master disconnect switch in the ON position.

**STEP 234**

Start and run the engine at low idle for two minutes.

**STEP 235**

Stop the engine and check for hydraulic oil leakage at the ride control valve.

**STEP 236**



BD00M041

Install the access cover.

**STEP 237**

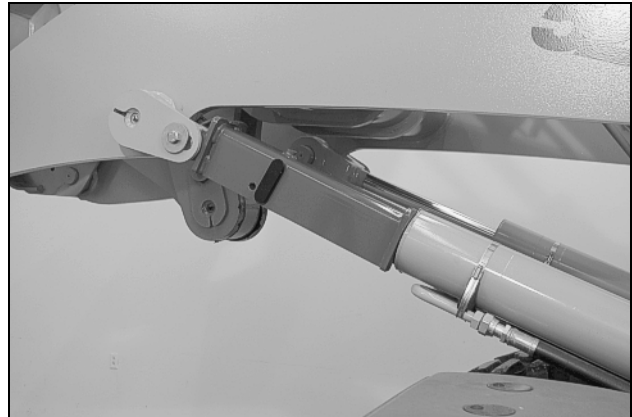

BD00M048

Raise the loader arms and remove the safety link.

**STEP 238**

Check the level of the hydraulic oil in the reservoir and add as required. Tighten the filler cap on the hydraulic reservoir.

**STEP 239**

Refer to Section 8002 and perform the Ride Control Test Procedure.

**STEP 7**

Subtract the reading of the test port (1) from the reading of the test port (2).

**STEP 8**

The difference between the two readings should be  $22 \pm 1/-0$  bar ( $320 \pm 15/-0$  psi).

**STEP 9**

If this reading is more or less than that specified, it will be necessary to adjust the pump.

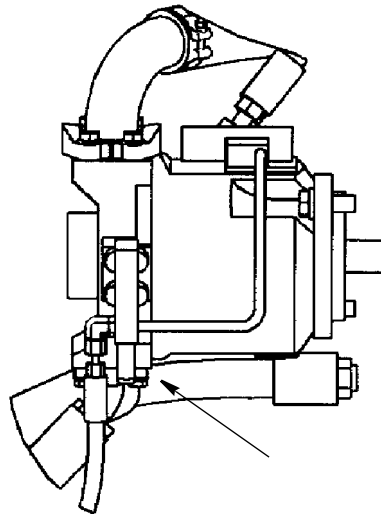
**Adjusting the Main Hydraulic Pump****STEP 10**

BS01B022

Turn the pump adjusting screw closest to the pump as illustrated. Turn the screw clockwise to increase the differential pressure. Turning the screw counterclockwise will decrease the differential pressure.

**NOTE:** One turn of the adjustment screw will change the pressure approximately 16 bar (230 psi).

**TESTING THE HYDRAULIC PUMP PERFORMANCE AND TORQUE LIMITER****STEP 1**

Make sure that the temperature of the hydraulic oil is at least 52°C to 60°C (125°F to 140°F). The following is the procedure for heating the hydraulic oil.

- A. Start the engine and run at high idle.
- B. Lower the loader bucket to the ground.
- C. Hold the lift control lever in the "FLOAT" position.
- D. Roll the bucket back against the stops and hold.

View the oil temperature by pressing the program switch, then press the up count switch to function 008. Return the program switch to the center (OFF) position.

**STEP 2**

Connect the flowmeter (5) by installing a tee fitting (1) between the pump and the loader control valve (2). Refer to illustration on page 9.

**STEP 3**

Make sure that the flowmeter valve is in the closed position. Raise the lift arms to the stops and secure the lift control lever in the "RAISE" position.

**STEP 4**

Operate the engine at 2000 rpm and open the flowmeter valve until the pump pressure is 500 psi. The flow at this point should be 36.5 to 37.5 gpm.

**STEP 5**

Close the flowmeter valve slowly and read the flow at 2000 psi @ 2000 rpm. The flow should read 35.5 to 36.5 gpm.

**STEP 6**

Continue slowly closing the flowmeter valve, monitoring the flow with the engine speed at 2000 rpm. At a point between 2200 and 2400 psi, the flow should noticeably start decreasing. This is the torque limit setting of the pump. Record this pressure.

## TABLE OF CONTENTS

PORTABLE FILTER .....	3
GENERAL INFORMATION .....	4
TYPES OF CONTAMINATION .....	4
CLEANING THE HYDRAULIC SYSTEM .....	5
FLUSHING WATER FROM THE HYDRAULIC SYSTEM .....	7

**NOTE:** The Case Corporation reserves the right to make improvements in design or changes in specifications at any time without incurring any obligation to install them on units previously sold.

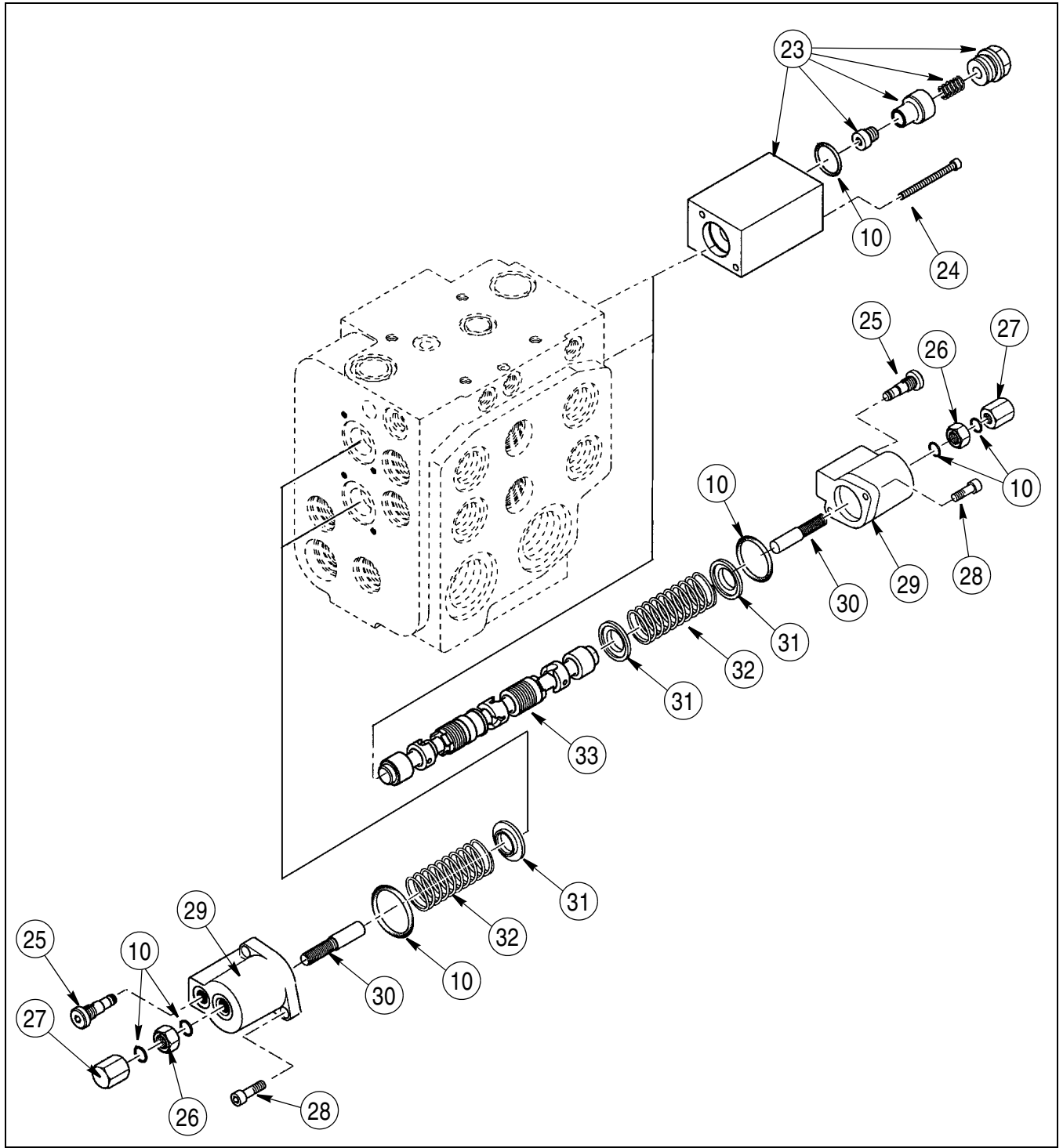

BS03C034

- |                            |                   |                     |
|----------------------------|-------------------|---------------------|
| 23. COVER (COMPONENTS NSS) | 27. CAP NUT       | 31. SPRING RETAINER |
| 24. BOLT                   | 28. BOLT          | 32. SPRING          |
| 25. PISTON                 | 29. COVER         | 33. SPOOL           |
| 26. JAM NUT                | 30. ADJUSTING ROD |                     |

**2 SPOOL VALVE SPOOL CONFIGURATION**

**STEP 2**

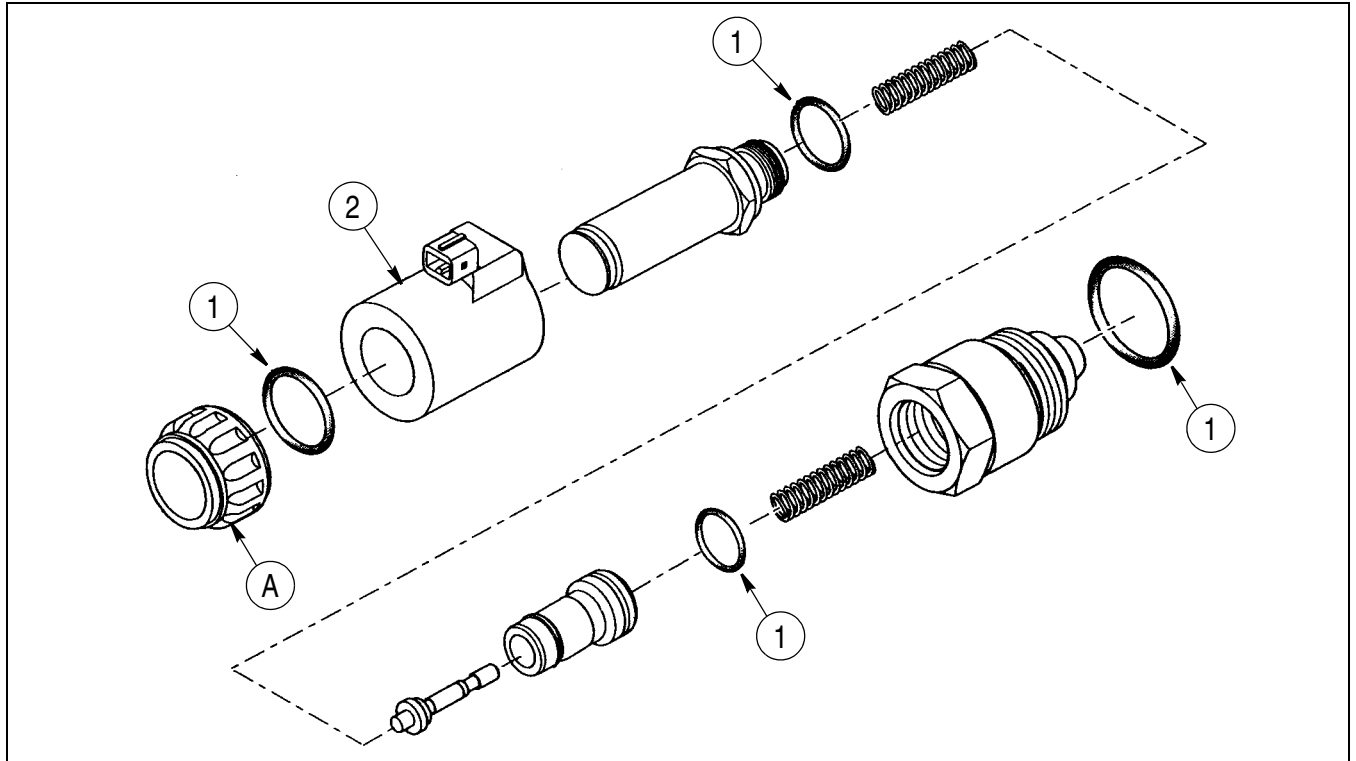

BS03C031

1. O-RINGS                      2. COIL

Install new O-rings and thrust rings on anticavitation valve (18). Hand tighten coil nut (A).

**STEP 3**

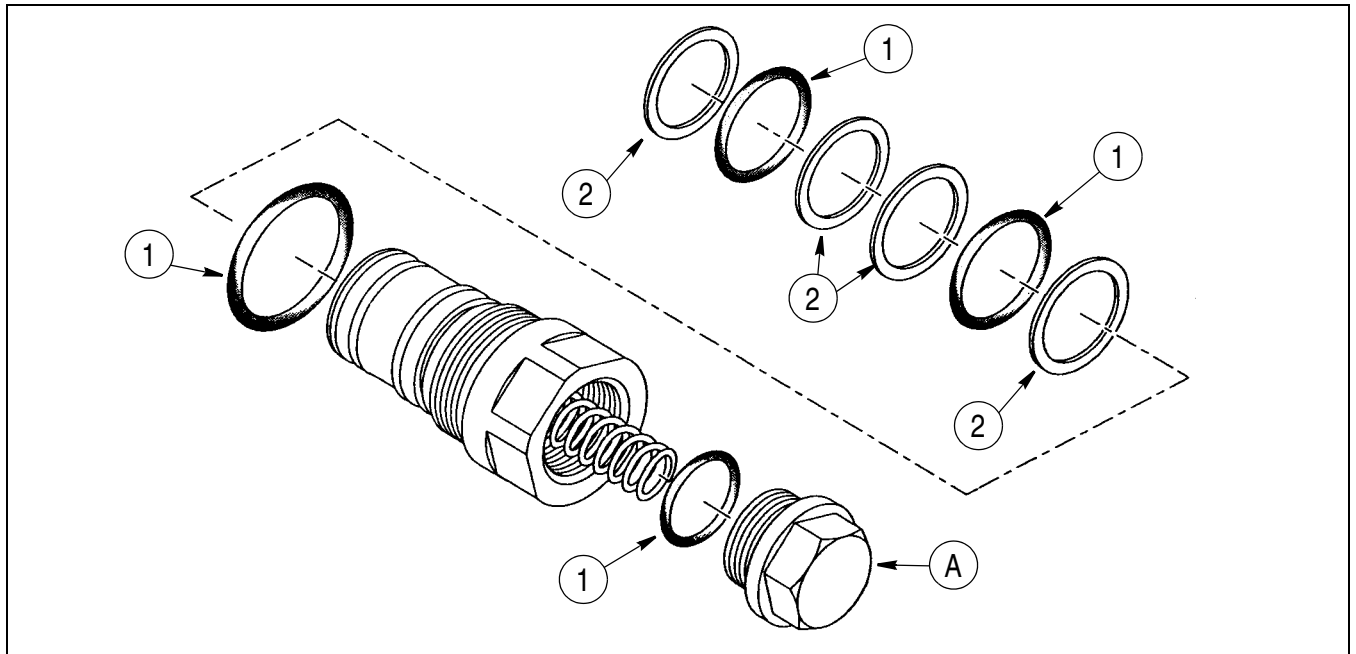

BS03C030

1. O-RINGS                      2. THRUST RINGS

Install new O-rings and thrust rings on anticavitation and pressure relief valves (19). Torque cap (A) to 100 Nm (73.7 lb-ft).

## BUCKET CYLINDERS Z-BAR MODELS

### Disassembly

1. Clean the outside of the cylinder. If the hoses were removed with the cylinder, remove the hoses from the cylinder.
2. Fasten the tube (1) in an acceptable repair stand or other holding equipment, refer to Figure 2. Do not damage the tube (1).
3. Loosen and remove the locking screw (12) from the gland (4) and tube (1).
4. Use a spanner wrench to loosen and remove the gland (4) out of the tube (1).
5. Pull the piston rod (12) straight out of the tube (1) to prevent damage to the tube (1).
6. Fasten the piston rod eye or yoke in a vise and put a support under the piston rod (12) near the piston (17). Put a shop cloth between the support and the piston rod (12) to prevent damage to the piston rod (12).
7. Use a torque multiplier, CAS-1039 to loosen and remove the bolt (15) that fastens the piston (17) to the piston rod (12).
8. Remove the piston (17) from the piston rod (12).
9. Remove the gland (4) from the piston rod (12).
10. Remove the seal (18), backup ring (19) and wear ring (20) from the piston (17).
11. Remove the O-ring (11), backup ring (10), wiper (5), seal (6), seal (7) and bushing (8) from the gland (4).

### Inspection

1. Discard the parts that were removed from the piston and the gland.
2. Clean all parts in cleaning solvent. Use only lint free cloths for cleaning and drying.
3. Check to be sure that the piston rod is straight. If the piston rod is not straight, replace it with a new piston rod.
4. Illuminate the inside of the tube for deep grooves and other damage. If there is any damage to the tube, replace it with a new tube.
5. Remove any small scratches on the piston rod or inside the tube with emery cloth of medium grit. Use the emery cloth with a rotary motion.
6. Inspect the bushings in the piston rod eye or yoke and the tube. Replace as required.
7. Inspect the gland for rust and clean and remove rust as necessary.
8. Inspect the gland end of the tube for sharp edges that will cut the gland O-ring and remove as necessary.
9. Inspect the piston for damage and wear. If the piston is damaged or worn, replace it with a new piston.

## COUPLER SOLENOID LOCKING VALVE

### Disassembly

#### STEP 1

Clean exterior of valve.

#### STEP 2

Remove nut (1) and solenoid (2) from valve cartridge (3).

#### STEP 3

Remove valve cartridge (3) from valve housing (7).

#### STEP 4

Remove and discard all O-rings (4 and 5) and back-up rings (6).

### Cleaning and Inspection

#### STEP 5

Immerse valve cartridge (3) and valve housing (7) in cleaning solvent and agitate cleaning solvent. **WEAR EYE PROTECTION WHEN USING COMPRESSED AIR.** Use compressed air to remove foreign matter from interior of valve cartridge and housing and to ensure that all passage ways and bores are clear.

#### STEP 6

Check valve cartridge for (3) for cracks, breaks, chipping, or other damage. Replace if any of these conditions are seen.

#### STEP 7

Check bores in valve housing (7) for deep scratches, gouges, and other damage. Replace valve if any of these conditions are seen.

#### STEP 8

Connect an ohmmeter across terminals of solenoid (2) connector. Replace solenoid (2) and valve cartridge (3) if ohmmeter indicates short or open circuit.

### Assembly

#### STEP 9

Install new O-rings (4 and 5) and back-up rings (6) as shown.

#### STEP 10

Lubricate O-rings (4 and 5) using clean oil then install valve cartridge (3) in valve housing (7).

#### STEP 11

Install solenoid (2) on valve cartridge (3).

#### STEP 12

Install nut (1) to secure solenoid (2).

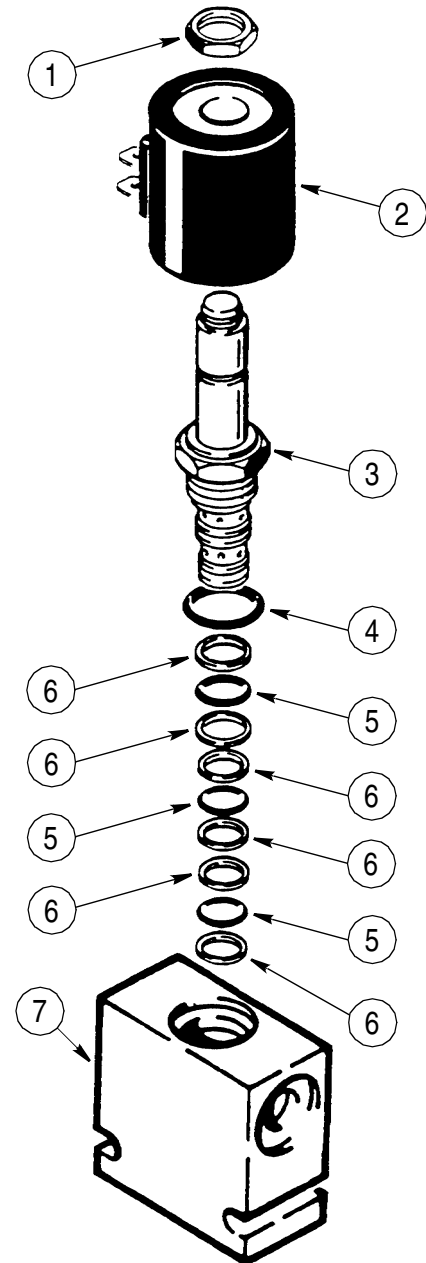

- |                    |                  |
|--------------------|------------------|
| 1. NUT             | 5. O-RING        |
| 2. SOLENOID        | 6. BACKUP RING   |
| 3. VALVE CARTRIDGE | 7. VALVE HOUSING |
| 4. O-RING          |                  |

GS98J818

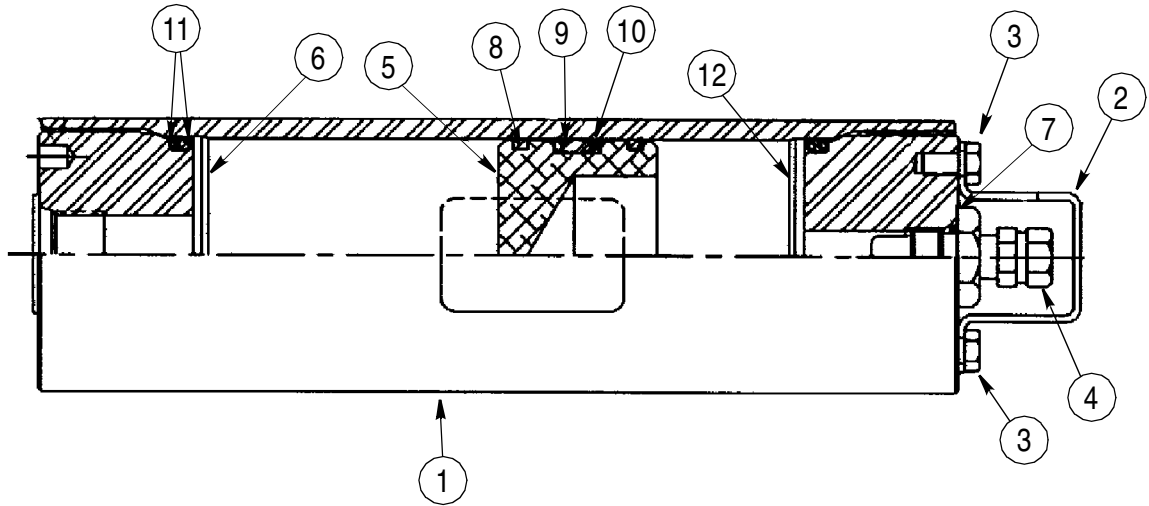

- |                   |              |                |
|-------------------|--------------|----------------|
| 1. BODY           | 5. PISTON    | 9. BACKUP RING |
| 2. GUARD          | 6. GLAND     | 10. O-RING     |
| 3. SCREW          | 7. O-RING    | 11. SEALS (2)  |
| 4. PRESSURE VALVE | 8. WEAR RING | 12. CAP        |
- PILOT PRESSURE ACCUMULATOR ILLUSTRATION - P.I.N. JEE0135500 AND BELOW**

BS01B224

**STEP 13**

Place the directional valve (8) into position on the logic cover (7). Secure the directional valve (8) with four mounting screws (9) and tighten screws.

**NOTE:** *Make sure R-rings remain in place and oil ports are properly aligned.*

**STEP 14**

Install new O-rings on the locking screws (3, 4, and 5), install and tighten locking screws.

**STEP 15**

Install the ride control valve in the machine, see section 8001.

**STEP 16**

Test the ride control system, see section 8002.

## PARKING BRAKE

### Checking the Parking Brake

1. Park the machine on a level surface.
2. The transmission must be in manual shift mode and the gear select must be in 3rd gear.

**NOTE:** *The Transmission Control Module will disconnect the transmission if any other gear is used.*

3. Press the program switch.
4. Press the up count switch until the display reads 011.
5. Press the program switch back to the center position.
6. Press the up count switch once.
7. Make sure the transmission selector is in 3rd neutral and the parking brake switch is on and in manual mode.
8. Shift the transmission selector into 3rd gear **FORWARD** and slowly increase engine rpm.
9. The parking brake should hold the machine at full throttle.
10. If the machine begins to move, decrease the engine speed and stop the engine. See Adjusting the Parking Brake in this section.
11. Press the reset switch to exit the test mode.

### Adjusting the Parking Brake

1. Park the machine on a level surface.
2. Start the engine and run at low idle with the service brakes engaged and the bucket resting on the ground throughout this procedure.
3. Release the parking brake.

**NOTE:** *Hydraulic pressure will not be applied to the parking brake until the parking brake rocker switch is turned off, the service brakes are applied, and the transmission is put into gear.*

- A. Set the parking brake rocker switch to the off position.
  - B. With the service brakes applied, put the machine into gear.
  - C. The parking brake light on the cluster will turn off at this time.
  - D. Put the transmission back into neutral before proceeding.
4. Remove the end cap (1), refer to the illustration on this page.

5. Release the lock nut (2) and turn the adjusting screw (3) clockwise until the two brake pads (4) make contact with the brake disc (5).
6. Turn the adjusting screw (3) counter clockwise and set the clearance, this should be 1/2 of one turn, refer to the table below.

Type	Adjusting Screw	Clearance (mm)		Revolutions
		Min.	Rated Clearance	
Small	M16 (size 8)	0.5	1/4	
		1.0	1/2	
		1.5	3/4	
Large	M20 (size 10)	1.0	2/5	
		2.0	4/5	
		3.0	1 1/5	

7. Hold the adjusting screw (3) in position with a allen head wrench and lock with the lock nut (2).
8. Install the end cap (1).
9. Perform the Checking the Parking Brake procedure again.
10. If the parking brake is still out of adjustment, see section 7008 and replace the brake shoes on the parking brake.

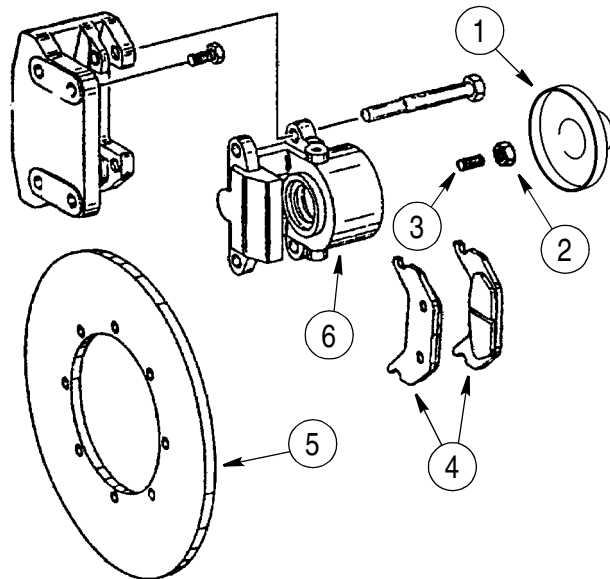

BS00N110

- |                    |                  |
|--------------------|------------------|
| 1. END CAP         | 4. BRAKE PADS    |
| 2. LOCK NUT        | 5. BRAKE DISC    |
| 3. ADJUSTING SCREW | 6. PARKING BRAKE |

### PARKING BRAKE

## SYSTEM CHECKS

### Mechanical Compressor Check

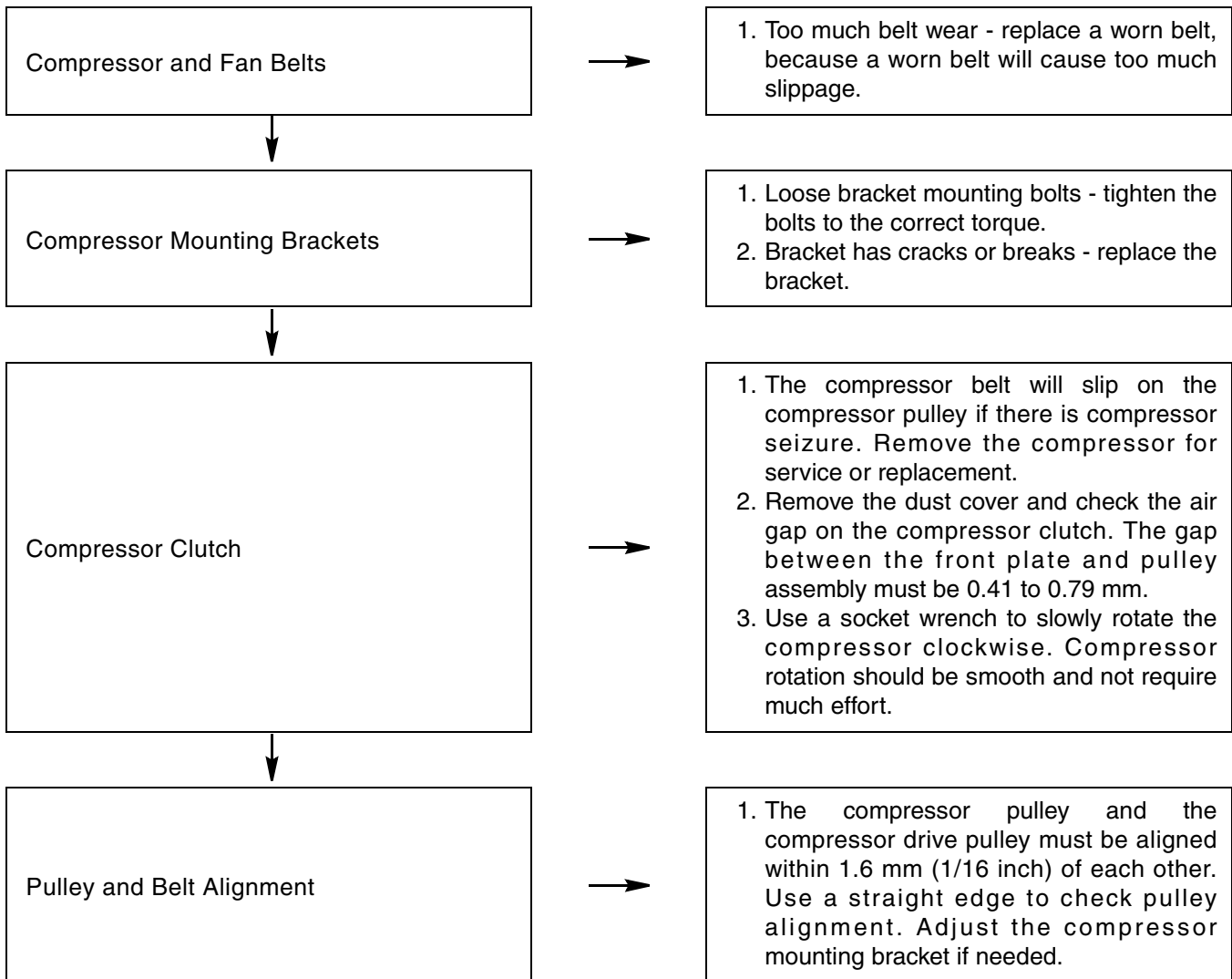

### Expansion Valve Malfunctioning - Indications:

- A. Discharge air from heater/evaporator warm.
- B. Much condensation on suction hose at compressor.
- C. Much condensation on evaporator outlet.



See Section 9004 and replace the expansion valve.

### Refrigerant Contamination:

Refrigerant Contamination



1. See table below and check stable saturation pressures at given temperature to determine if contamination exists.
    - A. Measure pressure from gauge on reclamation unit.
    - B. Measure temperature from refrigerant in reclamation tank. If refrigerant has been in reclamation unit for some time, use ambient temperature. The numbers in the table represent the boiling point for HFC-134a.
    - C. Pressure readings below range given in chart indicate contaminated refrigerant.
- IMPORTANT:** Do not use contaminated refrigerant or mix with uncontaminated refrigerant. Dispose of in accordance with all applicable laws and local procedure.

### HFC-134a Stable Saturation Pressure/ Temperature Chart

Temperature °F (°C)	Pressure PSIG (Bar)
50 (10)	45 (3.1)
55 (13)	51 (3.5)
60 (16)	57 (3.9)
65 (18)	64 (4.4)
70 (21)	71 (4.9)
75 (24)	78 (5.4)
80 (27)	88 (6.1)
85 (29)	95 (6.6)
90 (32)	104 (7.2)
95 (35)	114 (7.9)
100 (38)	124 (8.6)
102 (39)	129 (8.9)
104 (40)	133 (9.2)
106 (41)	138 (9.5)
108 (42)	142 (9.8)
110 (43)	147 (10.1)
112 (44)	152 (10.5)
114 (46)	157 (10.8)
116 (47)	162 (11.2)
118 (48)	167 (11.5)
120 (49)	172 (11.9)

## TABLE OF CONTENTS

SPECIFICATIONS .....	3
SPECIAL TOOLS .....	3
SAFETY PROCEDURES .....	4
AIR CONDITIONER SYSTEM REFRIGERANT RECOVERY .....	5
AIR CONDITIONER SYSTEM EVACUATION AND RECHARGING .....	7
PRESSURE - TEMPERATURE CHART .....	10

## TABLE OF CONTENTS

SAFETY PROCEDURES .....	3
SPECIAL TOOLS .....	4
COMPRESSOR REMOVAL .....	5
P.I.N. JEE0135500 and Below .....	5
P.I.N. JEE0135501 and Above .....	6
COMPRESSOR INSTALLATION .....	7
P.I.N. JEE0135500 and Below .....	7
P.I.N. JEE0135501 and Above .....	8
EXPANSION VALVE AND EVAPORATOR/HEATER CORE .....	10
Removal .....	10
Installation .....	12
CONTROL VALVE .....	15
Removal .....	15
Installation .....	15
CONDENSER .....	16
Removal .....	16
CONDENSER .....	17
Installation .....	17

### STEP 45

Remove the expansion valve from the evaporator/heater core.

### STEP 46

Remove and discard the O-rings from the openings in the expansion valve.

### STEP 47



BD01D265

Remove the hose clamps and the hoses from the evaporator/heater core.

### STEP 48

Remove the evaporator/heater core from the machine.

## Installation

### STEP 49

Install the evaporator/heater core in position in the machine.

### STEP 50



BD01D265

Connect the hoses and hose clamps to the evaporator/heater core.

### STEP 51

Lubricate new O-rings for the expansion valve with clean refrigerant oil.

### STEP 52

Install the new O-rings in the openings of the expansion valve.

### STEP 53

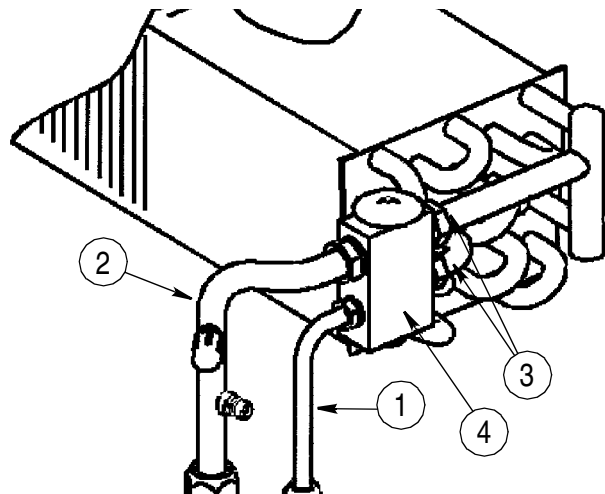

BS01D183

- |                 |                    |
|-----------------|--------------------|
| 1. LIQUID TUBE  | 3. FITTINGS        |
| 2. SUCTION TUBE | 4. EXPANSION VALVE |

Connect the fittings (3) of the evaporator/heater core to the expansion valve (4).

Connect the liquid (1) and the suction tube (2) to the expansion valve (4).

## RETURN TO DIG ADJUSTMENT (Z-BAR MODELS)

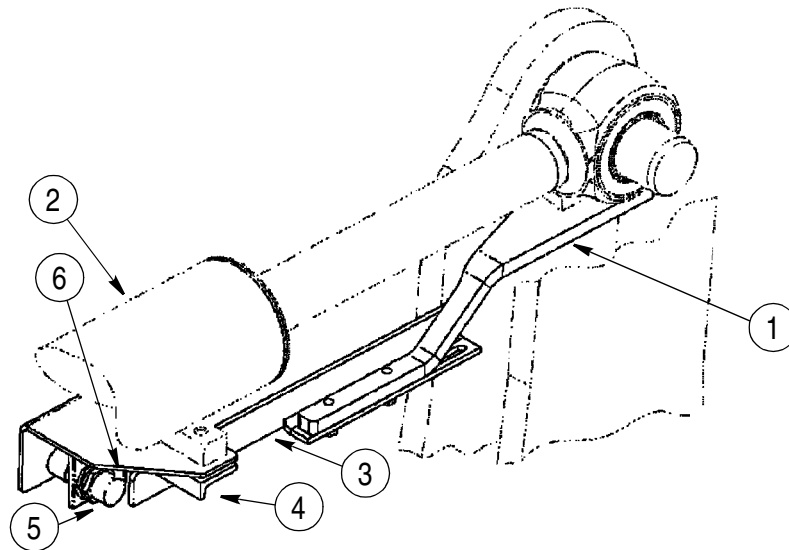

- |                            |                                      |                           |
|----------------------------|--------------------------------------|---------------------------|
| 1. TARGET MOUNTING BRACKET | 3. TARGET BAR                        | 5. PROXIMITY SWITCH       |
| 2. BUCKET CYLINDER         | 4. PROXIMITY SWITCH MOUNTING BRACKET | 6. PROXIMITY SWITCH GUARD |

BS01C083

### RETURN TO DIG ADJUSTMENT ILLUSTRATION Z-BAR MODELS

**IMPORTANT:** Before adjusting the return-to-dig, make sure that the target bar on the bucket linkage is not damaged. Slowly roll back and dump the bucket and make sure that the target bar stays the same distance from the switch. The switch mounting bracket protects the switch. Make sure the target bar cannot touch the switch when the bucket is dumped.

1. Park the machine on a level surface. Raise the lift arms until they are approximately horizontal and dump the bucket. Lower the bucket until the bucket edge is on the ground.
2. Apply the parking brake and stop the engine.
3. Loosen the bolts holding the target mounting bracket (1) to the tilt cylinder eye. Align the target mounting bracket (1) parallel to the tilt cylinder (2). Tighten the bolts, refer to the illustration on this page.
4. Loosen the bolts holding the proximity switch mounting bracket (4) to the tilt cylinder (2). Position the proximity switch (5) parallel to the target bar (3) and tighten the bolts.
5. Adjust the proximity switch (5) out towards the target bar (3), until an air gap of 3.5 to 5.0 mm (1/8 to 3/16 inch) is obtained. Torque the jam nut to 6 to 7.5 Nm (4.5 to 5.5 pound-feet).
6. Start the engine, position the bucket to the correct digging angle and stop the engine.
7. Loosen the bolts holding the target bar (3) to the target mounting bracket (1). Slide the target bar (3) towards the proximity switch (5) until the face of the proximity switch (5) is completely covered.
8. Align the target bar (3) parallel to the tilt cylinder (2) and tighten the bolts.
9. Turn the ignition switch to the ON position. Do NOT start the engine.
10. Place the bucket control lever in the ROLLBACK position.
11. Loosen the bolts holding the target bar (3) to the target mounting bracket (1).
12. Slide the target bar (3) slowly away from the proximity switch (5), until the control lever returns to the center position. Tighten the bolts holding the target bar (3).
13. Check to make sure that the 3.5 to 5.0 mm (1/8 to 3/16 inch) gap is still maintained.
14. Start the engine.
15. Place the detent switch in the ON position and place the return to travel/float detent switch to the TRAVEL position.
16. Raise the lift arms approximately horizontal, and put the bucket in the fully dumped position.
17. Place the loader control lever in the ROLLBACK position, and verify that the electromagnet holds it in that position until the end of the target bar (3) passes in front of the proximity switch (5).
18. Lower the lift arms and verify that the bucket is at the correct digging angle.

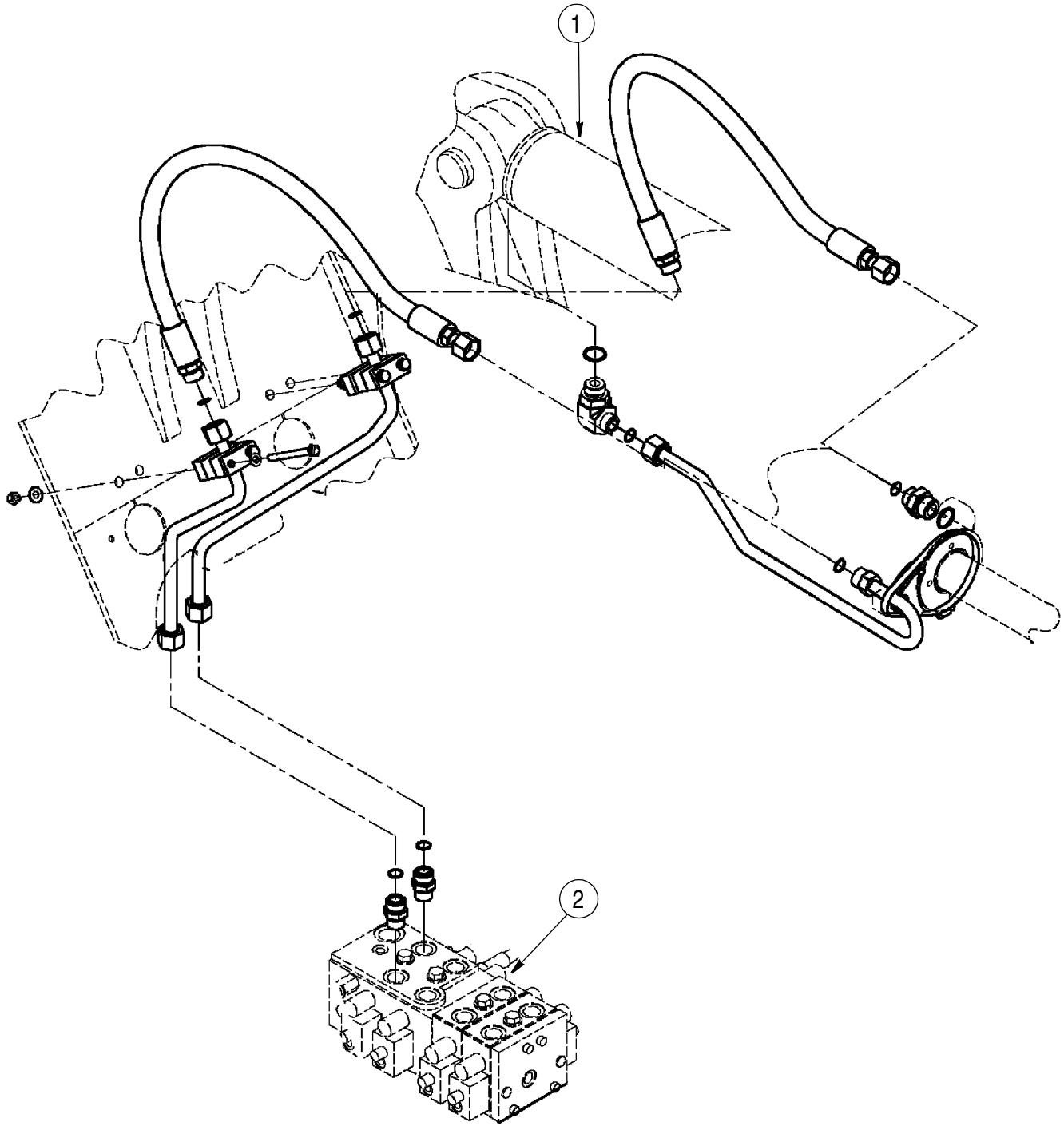

1. BUCKET CYLINDER

2. CONTROL VALVE

**BUCKET CYLINDER HYDRAULIC CIRCUIT - Z-BAR MODEL**

BS01C089

**STEP 25**

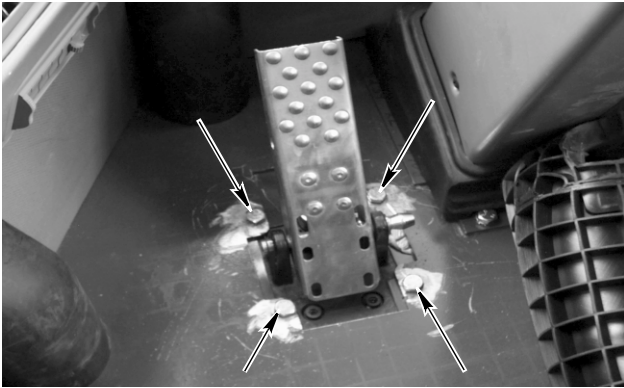

BD01D287

Remove hardware securing brake valve to cab floor. Let brake valve hang down from cab.

**STEP 26**

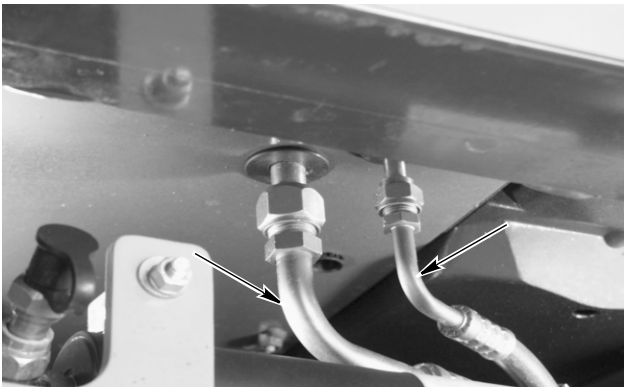

BD01D284

If machine has a ROPS cab and is equipped with air conditioning, refer to Section 9002 and discharge air conditioning system. At left rear bottom of cab, disconnect two hoses from air conditioning evaporator tubes. Remove and discard O-rings from evaporator tubes. Plug tubes and cap hoses to prevent entry of foreign matter.

**STEP 27**

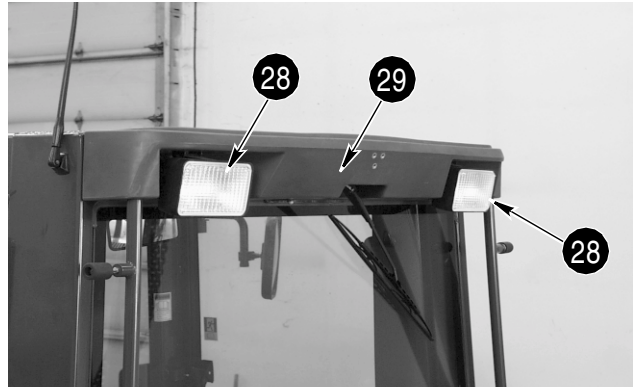

BD01D291

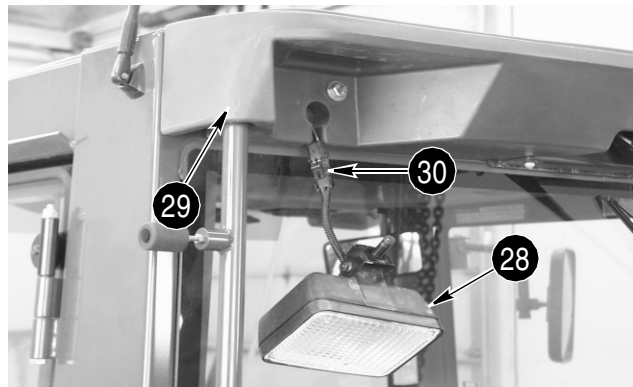

BD01D282

At top rear of cab, remove hardware securing LH flood light (28) to pod (29). Disconnect flood light connector (30) from wiring harness connector and remove flood light. Repeat this step to remove RH flood light.

**STEP 28**

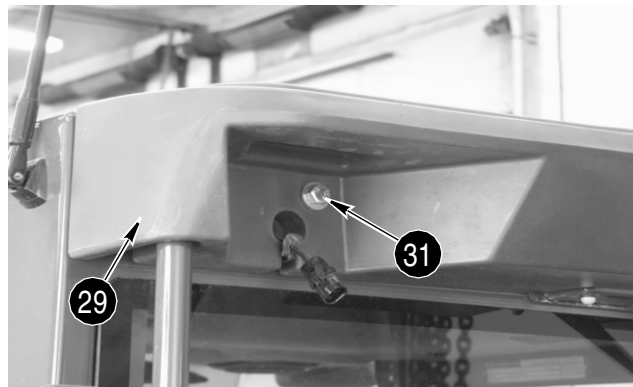

BD01D293

Remove two bolts (31) and washers. Remove pod (29) from cab.

CLICK HERE TO **DOWNLOAD** THE COMPLETE MANUAL

- Thank you very much for reading the preview of the manual.
- You can download the complete manual from: [www.heydownloads.com](http://www.heydownloads.com) by clicking the link below



- Please note: If there is no response to CLICKING the link, please download this PDF first and then click on it.

CLICK HERE TO **DOWNLOAD** THE COMPLETE MANUAL