

## 480D and 480LL TABLE OF CONTENTS

DIVISION/SECTION	SECTION NO.	FORM NO.
<b>1 GENERAL</b>		
Safety Rules, Service Manual Introduction, and Torque Specifications .....	1001	9-69260
Maintenance and Lubrication .....	1002	9-69260
General Engine Specifications .....	1010	8-23060
Detailed Engine Specifications .....	1027	9-78675
<b>2 ENGINES</b>		
Engine Diagnosis .....	2001	9-78875
Engine Tune-Up .....	2002	9-78825
Engine Stall Tests .....	2003	9-69260
Engine Removal and Installation .....	2004	9-69260
Engine Accessories .....	2005	9-69260
Cylinder Head, Valve Train and Camshaft .....	2015	9-78836
Cylinder Block, Sleeves, Pistons and Rods .....	2025	9-78855
Crankshaft, Bearings, Flywheel and Oil Seals .....	2035	9-78866
Oil Pump .....	2045	9-78885
Cooling System .....	2055	9-78816
Engine Lubrication .....	2555	9-78985
<b>3 FUEL SYSTEM</b>		
Fuel Filters .....	3010	8-22771
Fuel Injection Pump .....	3012	9-78795
Fuel Injectors .....	3013	9-78807
Fuel Lines, Fuel Tank, and Engine Controls .....	3052	9-69260
<b>4 ELECTRICAL</b>		
Electrical System Troubleshooting .....	4002	9-69260
Wiring Diagrams .....	4003	9-69260
Batteries .....	4005	9-69260
Starter .....	4006	9-69260
Alternator .....	4007	9-69260
Instrument Cluster and Instrument Panel .....	4009	9-69270
<b>5 STEERING</b>		
Steering System Troubleshooting .....	5002	9-69260
Steering Pump .....	5005	9-69270
Steering Control Valve and Steering Column .....	5007	9-69260
Steering Cylinders .....	5010	9-69260
Front Axle .....	5021	9-69270
<b>6 POWER TRAIN</b>		
Power Shuttle Troubleshooting .....	6202	9-69260
Power Shuttle and Torque Converter .....	6210	9-69260
Power Shuttle Controls .....	6211	9-69260
Transaxle Removal and Installation .....	6212	9-69260
Transaxle and Differential Lock .....	6214	9-79237
Driveshaft .....	6222	9-69270
Wheels and Tires .....	6229	9-69260

CLICK HERE TO **DOWNLOAD** THE COMPLETE MANUAL

- Thank you very much for reading the preview of the manual.
- You can download the complete manual from: [www.heydownloads.com](http://www.heydownloads.com) by clicking the link below



- Please note: If there is no response to CLICKING the link, please download this PDF first and then click on it.

CLICK HERE TO **DOWNLOAD** THE COMPLETE MANUAL

## FLUIDS AND LUBRICANTS

COMPONENT	CAPACITY		SPECIFICATIONS
	U.S.	Metric	
Fuel tank	23.5 gallons	89 litres	See Operators Manual
Engine crankcase			
Without filter change	6 quarts	5.7 litres	Case HDM Oil
With filter change	7 quarts	6.6 litres	API Classification CD Above 32° F (0° C) ..... SAE 30 10 - 50° F (-12° - 10° C) ..... SAE 20W20 Below 32° F (0° C) ..... SAE 10W
Hydraulic reservoir	11 gallons	41 litres	Case TCH Fluid Alternate oil:  Engine oil SC, service class C Above 32° F (0° C) ..... SAE 20 Below 32° F (0° C) ..... SAE 10W <b>NOTE:</b> Do not mix engine oil and TCH Fluid.
Power shuttle transmission	8 quarts	7.6 litres	Case TCH Fluid
Transaxle	20 quarts	18.9 litres	Case FDL Final Drive Lube Alternate oil:  Gear Lubricant (API-GL-4) Above 0° F (-18° C) ..... SAE 90 Below 0° F (-18° C) ..... SAE 80
Engine cooling system			
With heater	18 quarts	17 litres	Mix an ethylene glycol coolant with water for the lowest outside temperature that is expected. The mixture must be at least 50%50.
Without heater	14 quarts	13.2 litres	
Battery	As required		Add drinking water or distilled water.
Grease fittings	As required		No. 2 Molydisulfide grease
Wheel bearings	As required		Wheel bearing grease
Brake master cylinder (See Note)	As required		Case TCH Fluid Alternate oil:  Automatic transmission fluid (ATF) such as Dexron II.
Parking brake cable	As required		Lubriplate 105 grease.

**NOTE:** DO NOT use brake fluid in the brake system of this machine. Use the oil shown under Specifications only. Brake fluid will cause damage to the brake system.

**Exhaust Valve**

	U.S. Value	Metric Value
Tappet clearance (COLD and HOT) .....	.014"	.356mm
Face angle .....	44°	44°
Face run-out (max.) .....	.002"	.051mm
O.D. of head .....	1.398 to 1.408"	35.509 to 35.763mm
O.D. of stem .....	.3399 to .3409"	8.634 to 8.659mm
Minimum Serviceable Limit .....	.3389"	8.608mm
Length .....	6.340 to 6.364"	161.036 to 161.646mm
Insert seat angle .....	45°	45°
Seat contact width .....	.0608 to .0962"	1.544 to 2.443mm
Seat run-out (max.) .....	.002"	.051mm
Insert height .....	.2475 to .2525"	6.286 to 6.413mm
O.D. of insert .....	1.4495 to 1.4505"	36.817 to 36.843mm
I.D. of insert .....	1.245 to 1.255"	31.623 to 31.877mm

**Intake Valve Guides**

Length .....	3.250"	82.550mm
O.D. ....	.6565 to .6575"	16.675 to 16.701mm
I.D. (installed and reamed) .....	.3429 to .3439"	8.710 to 8.735mm
Maximum Serviceable Limit .....	.3449"	8.761mm
Protrusion above cylinder head .....	.875"	22.225mm
Valve stem clearance in guide .....	.001 to .003"	.025 to .076mm
Maximum Serviceable Limit .....	.004"	.102mm

**Exhaust Valve Guides**

Length .....	3.125"	79.375mm
O.D. ....	.6565 to .6575"	16.675 to 16.701mm
I.D. (installed and reamed) .....	.3429 to .3439"	8.710 to 8.735mm
Maximum Serviceable Limit .....	.3449"	8.761mm
Protrusion above cylinder head .....	.875"	22.225mm
Valve stem clearance in guide .....	.002 to .004"	.051 to .102mm
Maximum Serviceable Limit .....	.005"	.127mm

**Valve Spring**

Free length .....	2.375"	60.325mm
Total coils .....	8.25	
Wire diameter .....	.162"	4.115mm
I.D. ....	.958 to .978"	24.333 to 24.841mm
Compressed to 1.521" (38.63mm) (valve open) .....	110 to 118 lbs.	49.90 to 53.52 kg
Compressed to 1.875" (47.63mm) (valve closed) .....	53 to 59 lbs.	24.04 to 26.76 kg

# ENGINE MISFIRES

## Low and High RPM

### 1. Wrong Fuel or Contaminated Fuel

Wrong fuel (low centane) or contaminated fuel (water and dirt) can cause the engine not to run or to have pre-combustion, causing serious damage to the engine. Drain fuel tank and re-fill with correct fuel.

### 2. Valve Push Rods Bent

Bent push rods will affect valve operation and not allow cylinders to get a full charge of fuel and air, or not exhaust properly. This can usually be distinguished by excessive valve tappet noise. Remove cylinder cover and check for bent push rods.

### 3. Fuel Injection Nozzles Malfunctioning

Low cracking pressure, improper spray pattern or plugged orifice will affect proper combustion in engine cylinders. Isolate faulty injector nozzle and remove.

### 4. Fuel Injection Nozzle Not Seated in Head

A fuel injection nozzle that is not seated in the cylinder head will let compression leak by and the cylinder does not produce enough heat to fire the injected diesel fuel. A damaged nozzle gasket or seals, loose nozzle, or broken stud can cause the nozzle not to be seated correctly.

### 5. Cylinder Head Gasket Blown

A blown cylinder head gasket will cause one or two cylinders to lose power and cause an engine to miss. Compression leaking into the water system can also cause the cooling system pressure to rise and blow engine coolant out the radiator overflow. Take a compression test to help determine a defective head gasket, or remove radiator cap, run engine and check for gas bubbles rising in coolant at radiator opening.

### 6. Low Compression

Low compression on several cylinders, makes the engine hard to start and rough running, also does not generate enough heat to properly fire on all cylinders. Make a compression test on the engine.

### 7. Fuel Injection Line Cracked

A cracked, chaffed or damaged fuel injector line will allow fuel to escape externally and inject fuel into the cylinder. This will cause an engine miss and low horsepower. Leaking fuel from a damaged injector line can easily be seen.

### 8. Injection Pump Malfunction.

A malfunctioning injection pump will usually under-fuel the engine. A common cause is a sheared key on the injection pump drive, preventing fuel to be delivered to injectors. Adjust or replace the injection pump or parts as required.

### 9. Injection Pump Timing Incorrect

A fuel injection pump timed at wrong degrees, wrong stroke, or marks moved on pulley, will inject fuel into the cylinders at the wrong time, causing rough running, pre-combustion, low horsepower and other damage to the engine. Check for proper pump timing.

### 10. Intake Manifold Gasket Damaged

A damaged intake manifold gasket can reduce the manifold pressure and cause an insufficient air-fuel mixture in the cylinders and result in low power.

### 11. Cylinder Head or Sleeve Cracked

A cracked head or sleeve will usually let engine coolant into the engine. This will cause an engine miss or pressure rise in the cooling system depending on how bad the leak is. Low coolant level, oil level, engine missing, and blowing water out the exhaust are evidence that coolant is getting into the engine combustion chambers.

# LOW ENGINE OIL PRESSURE

## Internal Problems

### 1. Engine Low On Oil

An engine low on oil could lose lubrication to internal parts and start scoring pistons, sleeves and damage engine bearings. Proper oil level is required to help dissipate some of the engine heat. Check engine oil level every eight hours of operation. Low engine oil can also give low oil pressure readings.

### 2. Oil Pump Relief Malfunction

Low engine oil pressure readings can be caused by a malfunctioning oil pump relief valve. A broken spring, a piece of metal under valve seat or abrasives could cause relief valve to score and hang up. Remove engine oil pan and oil pump assembly. Inspect pump relief valve and repair as necessary.

### 3. Engine Oil Too Light

Using engine oil that is too light will aggravate all oil consumption areas because of additional oil flow and leakage of the lighter oil. Light engine oil will give lower than normal oil pressure readings. Check for proper weight oil and change oil if required.

### 4. Oil Pump Suction Assembly Off Pump

It is possible for the oil pump suction assembly to come off the engine oil pump from improper installation, defective threads or jam nuts or worn cotter pin holding on the suction screen. With the pick up screen off, the pump would have little or no oil pressure. Remove oil pan and inspect oil pump suction assembly.

### 5. Engine Oil Pump Worn

The engine oil pump can be worn from long service, contaminates in the oil, improper installation or no backlash in pump drive gear. Remove engine oil pan and inspect oil pump.

### 6. Engine Main Bearings Worn

A worn main bearing will have a thudding sound and increased engine vibration. Both symptoms will increase as engine speed increases.

By grounding out (cracking injector line) the problem cylinder, the thudding sound will stop or decrease but the vibration will remain. Remove engine oil pan and check main bearing clearance with plasti-gauge. Also, low oil pressure can be the result of worn main bearings and excessive oil clearance.

### 7. Connecting Rod Bearings Worn

Worn rod bearings cause more than normal throw off of lubricating oil to cylinder pistons and liners. This excess oil is sometimes more than worn piston oil rings can control. The oil then passes the rings and on into the combustion chamber. Remove the engine oil pan and check rod bearings for wear using plasti-gauge. A worn rod bearing can cause the engine to knock and low oil pressure.

### 8. Rocker Arm Shafts Indexed Wrong

Incorrect rocker arms or rocker arm shafts indexed wrong can lead to excessive oil in the rocker arm compartment. This oil aggravates oil consumption especially past valve guides. Remove valve cover and check oil flow from rocker arm assemblies.

### 9. Rocker Arm Assembly Worn

Worn rocker arm assemblies allow larger than normal amounts of lubricating oil into the valve compartment. The extra quantity of oil increases oil consumption past the valve guides. Run the engine with valve cover removed and check for excessive oil or oil flow from the rocker arms.

### 10. Oil Pump Suction Screen Plugged

The oil pump suction screen can become plugged with sludge, metal filings and other contaminants in the oil. Many times the oil pressure will be normal when engine is first started. The longer the unit runs, the more contaminants are collected on the pick-up screen shutting off the supply of suction oil. Remove engine oil pan and inspect oil pump screen.

I  
ENGINE TUNE-UP CONTINUED

CHECKING COMPRESSION  
See Steps 31 thru 38

INSTALLING FUEL INJECTOR NOZZLES  
See Step 39

CLEANING FUEL LINE SCREEN AND FUEL FILTERS  
See Step 40

RETIMING FUEL INJECTION PUMP  
See Steps 41 thru 49

INSTALLING VALVE COVER  
See Steps 50 thru 53

ADJUSTING GOVERNED SPEED  
See Step 54

# Section 2003

## ENGINE STALL TESTS

Written In *Clear  
And  
Simple  
English*

- 32. If a vacuum pump is available, connect the vacuum pump to the hydraulic reservoir. Start and run the vacuum pump to keep the oil in the hydraulic reservoir while the hoses are disconnected from the hydraulic pump.
- 33. If a vacuum pump is not available, see Section 8002 and drain the oil from the hydraulic reservoir.
- 34. Disconnect the hose from the fitting in the outlet side of the hydraulic pump.

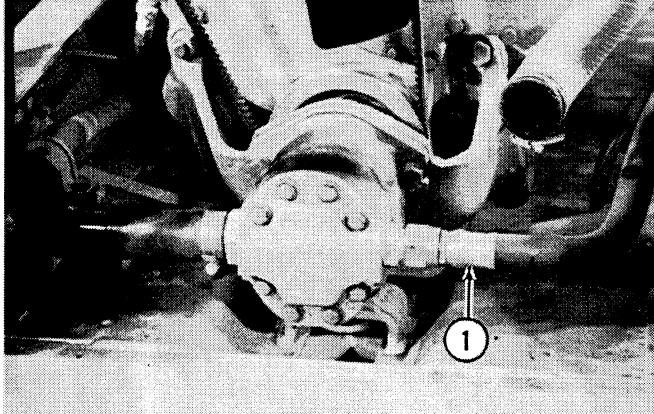

1. Hose

Figure 33

- 35. Install a cap on the fitting and a plug in the hose to keep dirt out of the hydraulic system.

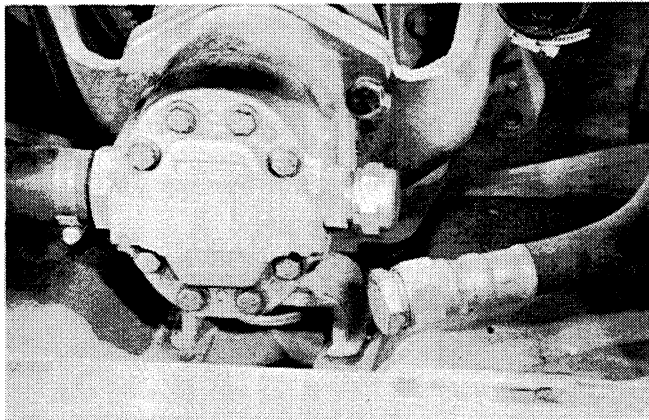

Figure 34

- 36. Loosen the clamps on the hose at the inlet side of the hydraulic pump.



Figure 35

- 37. Pull the hose from the fitting in the inlet side of the hydraulic pump.

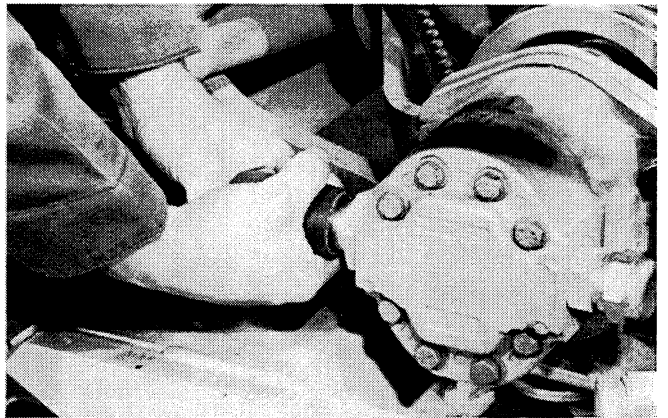

Figure 36

- 38. Put caps on the fitting and on the tube to keep dirt out of the hydraulic system.

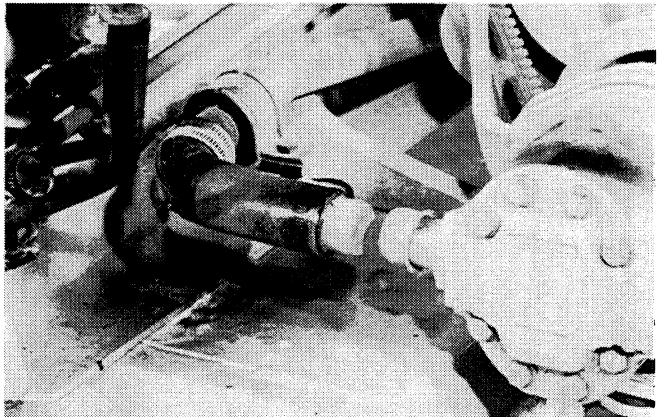
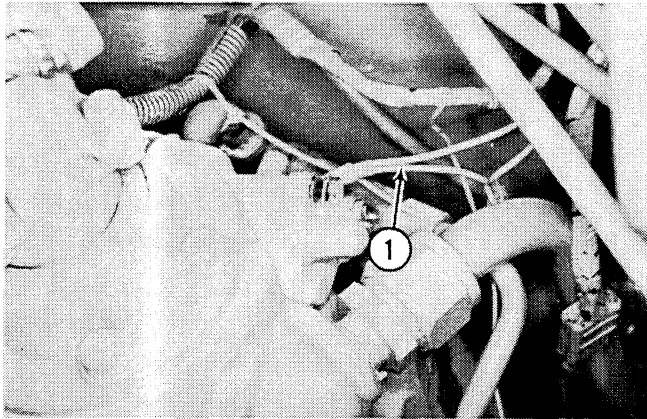

Figure 37

13. Connect the ground wires to the power shuttle.



1. Ground Wires  
Figure 98

14. Connect the wire to the oil temperature gauge sender.

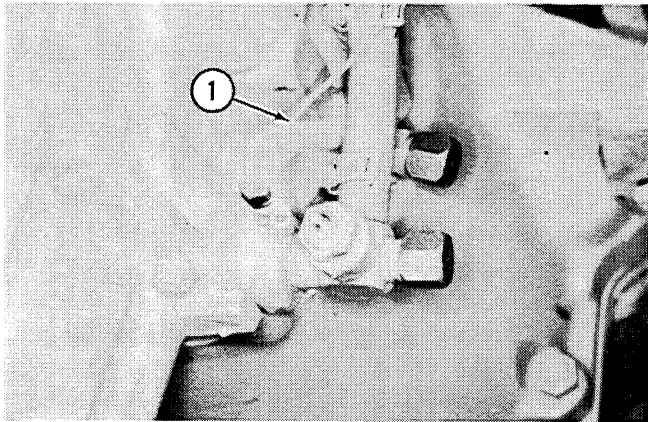

1. Wire  
Figure 99

15. Connect the harness plug to the neutral start switch.

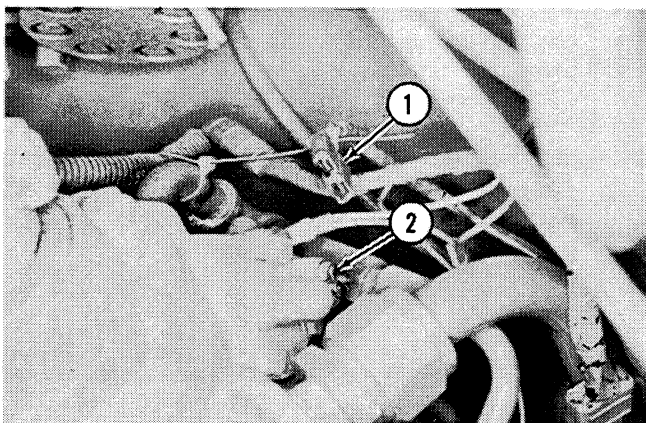

1. Harness Plug  
2. Neutral Start Switch  
Figure 100

16. Connect the engine harness to the main harness.

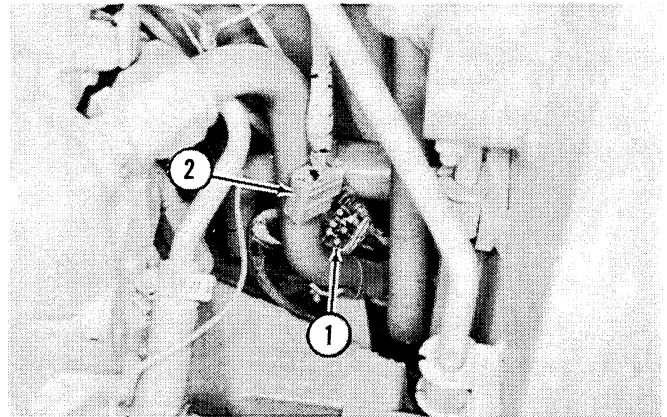

1. Engine Harness  
2. Main Harness  
Figure 101

17. Connect the hoses to the fittings in the power shuttle.

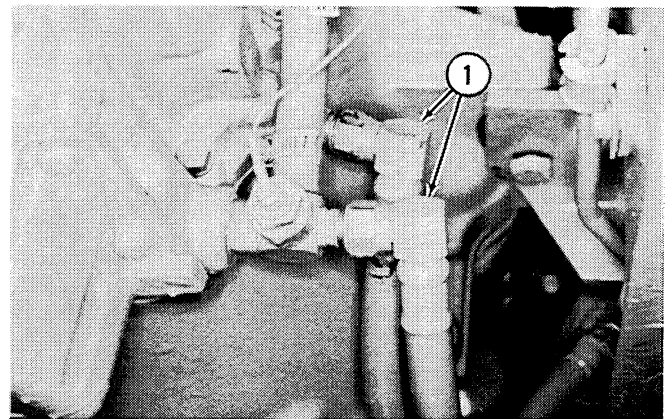

1. Hoses  
Figure 102

18. Install the drain plug in the power shuttle.

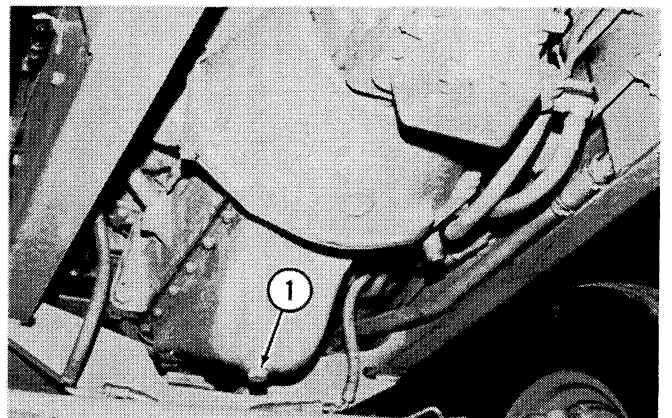

1. Drain Plug  
Figure 103

8. Loosen and remove the cap screws and lock washers that fasten the starter to the engine.

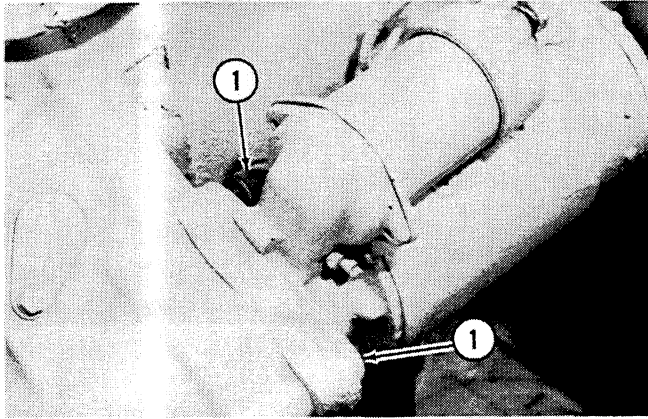

1. Cap Screw

Figure 168

9. Remove the starter from the engine.

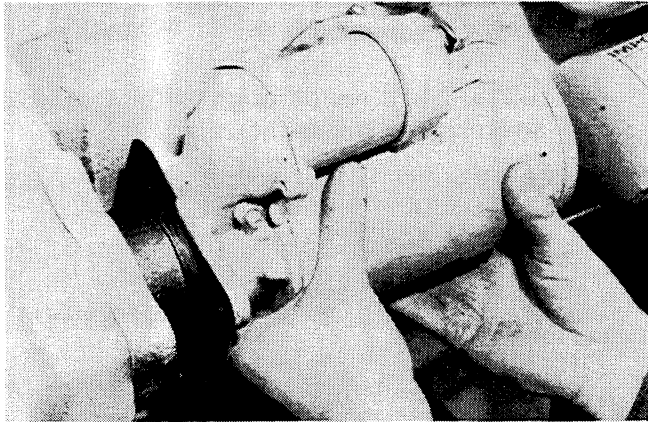

Figure 169

10. Loosen and remove the hardware that fastens the torque converter housing to the engine.

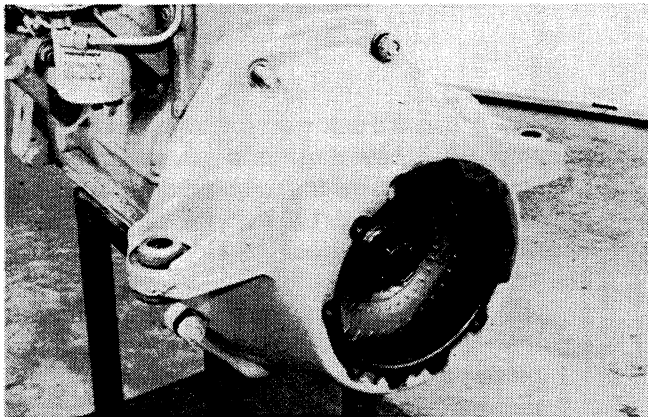

Figure 170

11. Remove the torque converter housing from the engine.

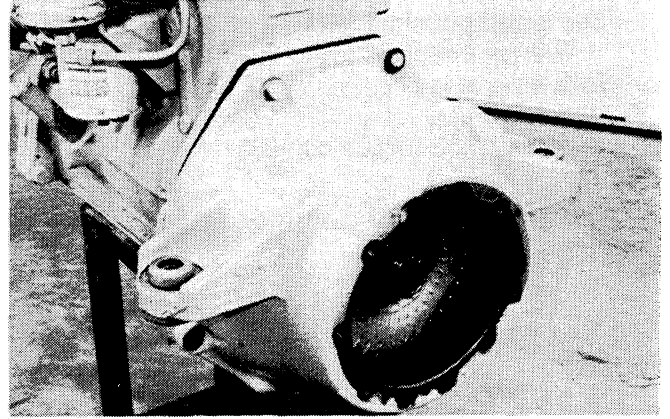
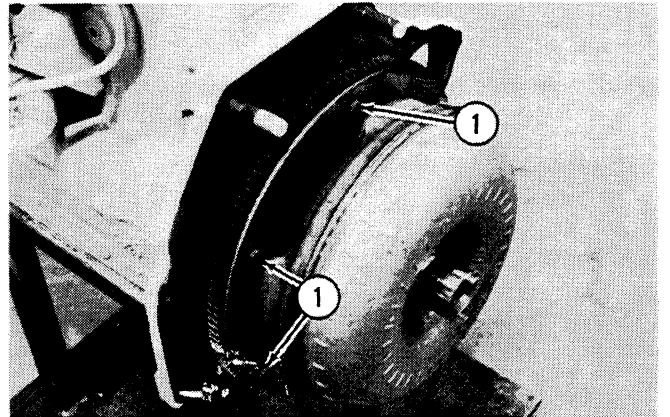

Figure 171

12. Loosen and remove the cap screws and flat washers that fasten the flex plate for the torque converter to the flywheel.



1. Cap Screws

Figure 172

13. Remove the torque converter and flex plate from the flywheel.

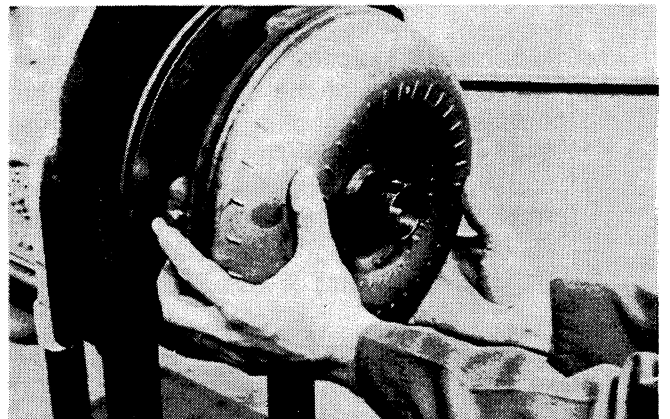

Figure 173

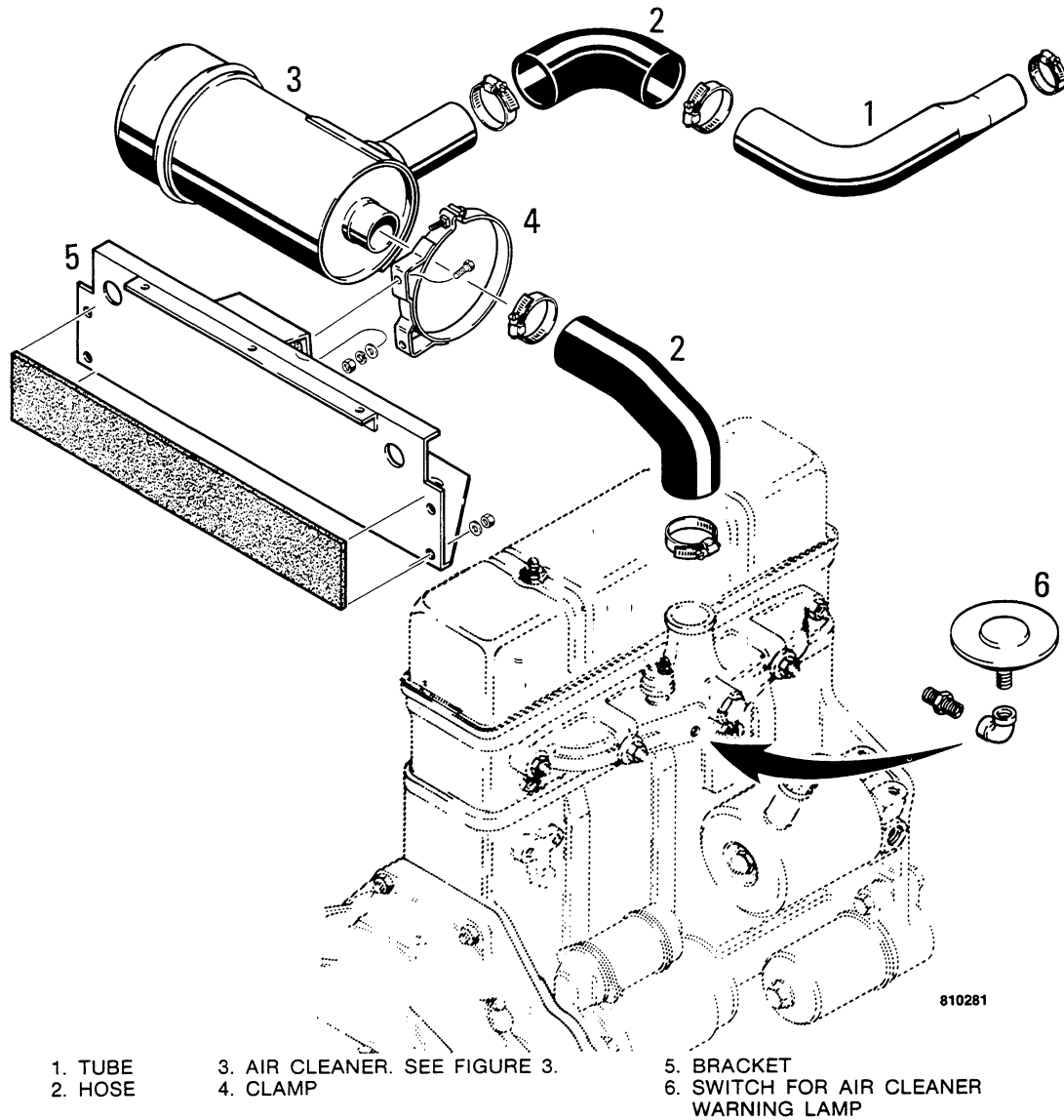

Figure 2 - Air Cleaner Installation With Noise Control

12. Install the grille.

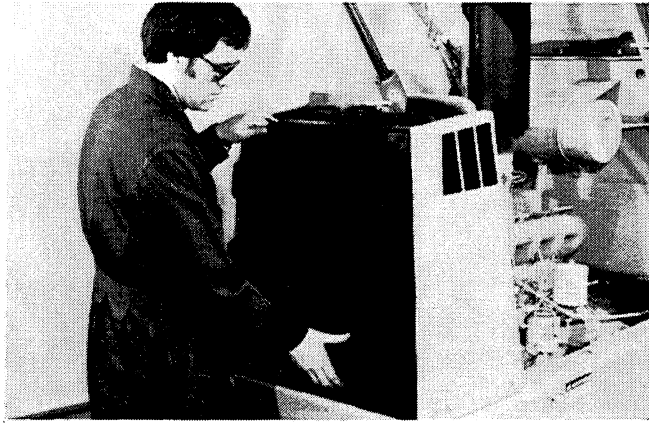

Figure 42

13. Install the bolts and flat washers to fasten the grille in place.

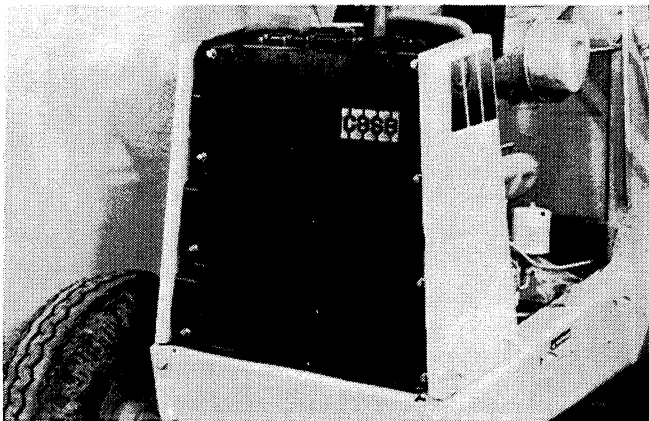

Figure 43

14. Install the hood.



Figure 44

15. Make sure the rear of the hood is in position under the instrument panel plate and lower the hood onto the shroud.

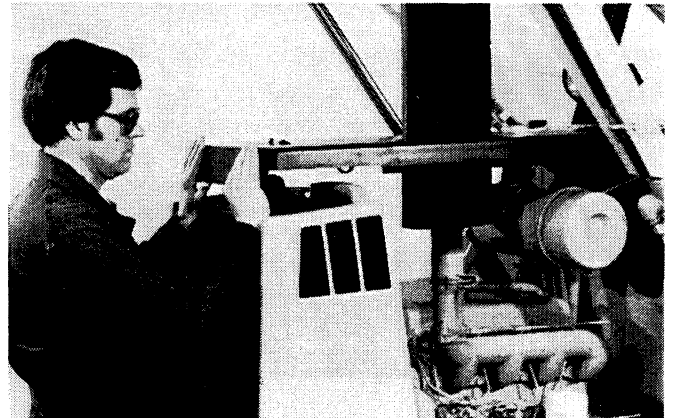
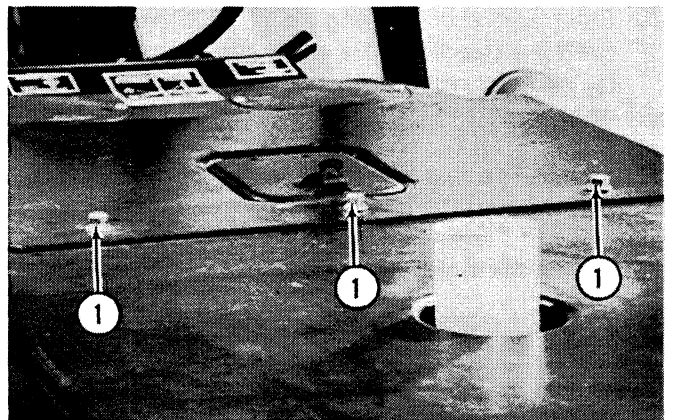

Figure 45

16. Tighten the cap screws in the instrument panel plate to fasten the rear of the hood in place.



1. Cap Screws

Figure 46

17. Install the cap on the air cleaner.

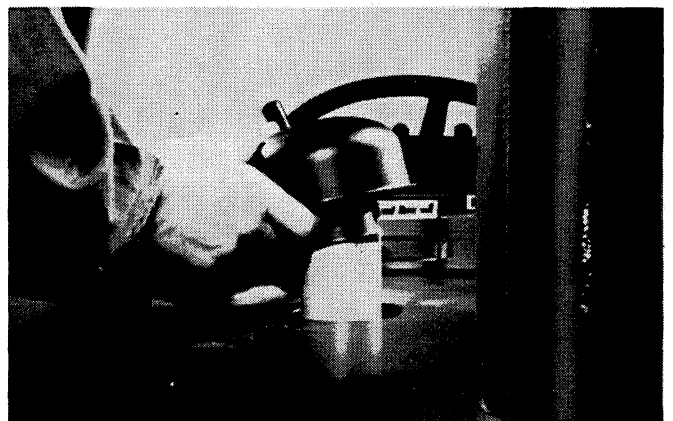
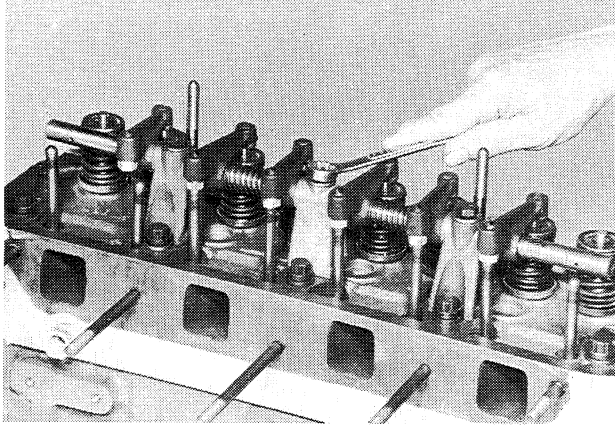

Figure 47

**STEP 17**



Remove remaining three rocker arm assembly bracket bolts.

**STEP 20**

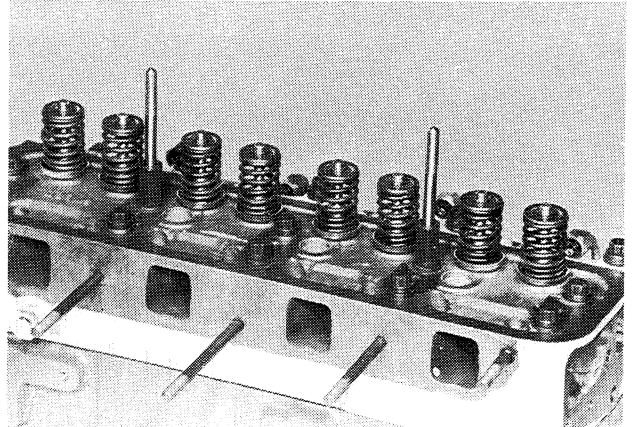

Rocker arm assembly and push rods removed.

**STEP 18**

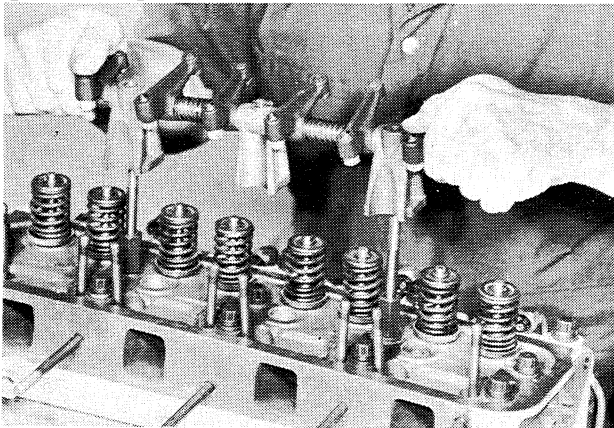

Remove remaining rocker arm assembly. *NOTE:* Tie the assembly together to prevent parts from falling apart.

**STEP 21**

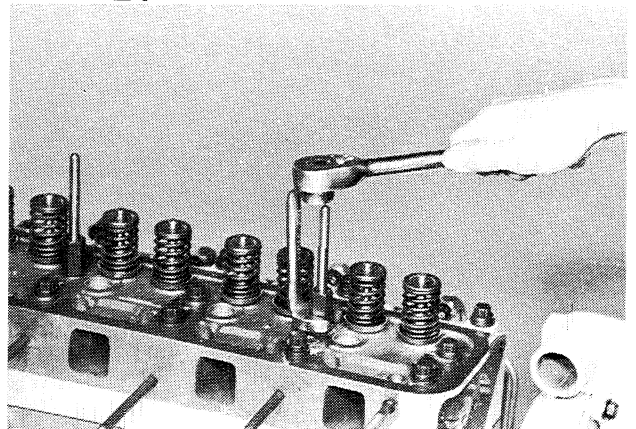

Loosen valve cover stud and nut assemblies using M20419 cylinder head wrench.

**STEP 19**

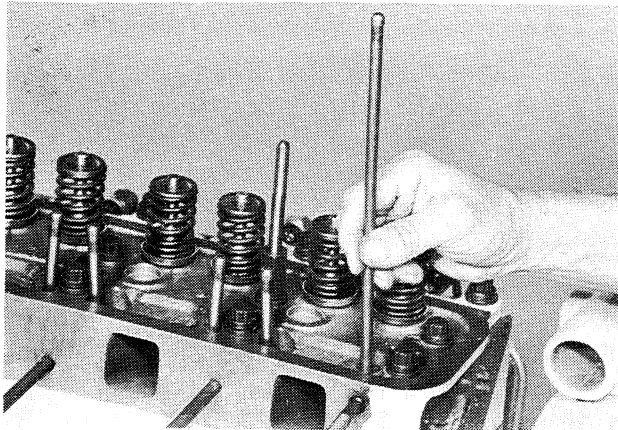

Remove push rods.

**STEP 22**

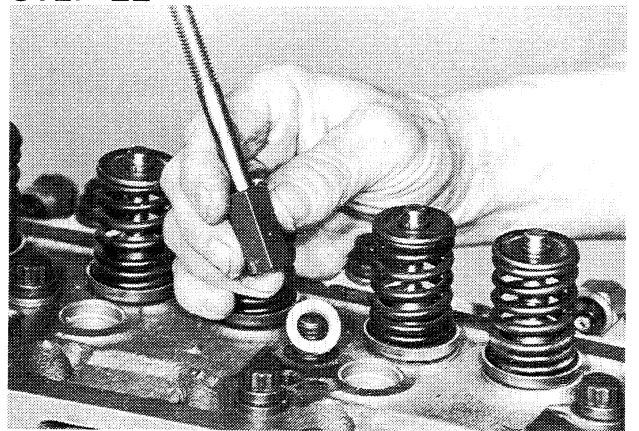

Remove valve cover mounting stud and nut assemblies and washers.

# Diagnosis of Various Bluing Patterns

## 15° INTAKE OR EXHAUST VALVES

**SEAT CONTACT AREA ON VALVE TOO LOW**

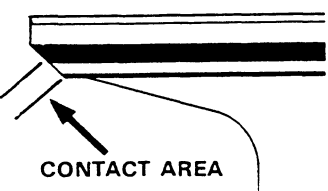

CONTACT AREA

If valve contact area on seat looks like this (previously ground seat).

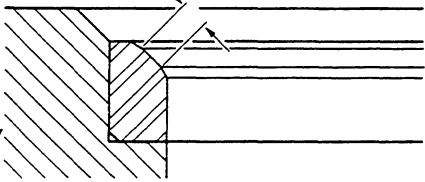

Use a 45° stone to raise and widen contact area

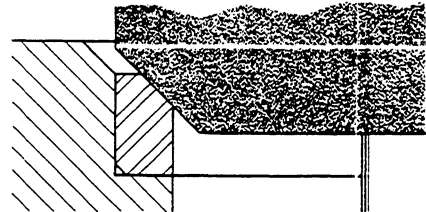

If valve contact area on seat looks like this.

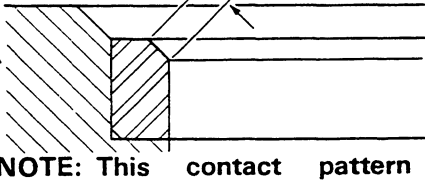

**NOTE:** This contact pattern will also be found on intake valves without replaceable seats.

Use a 45° stone to raise contact area.

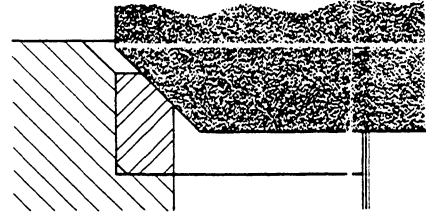

Use a 60° narrowing stone to narrow lower contact area increased by 45° stone.

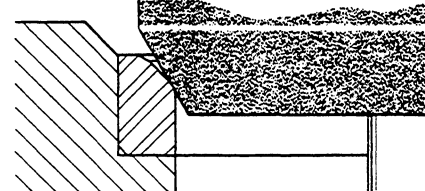

Use a 60° narrowing stone to raise and narrow lower contact area.

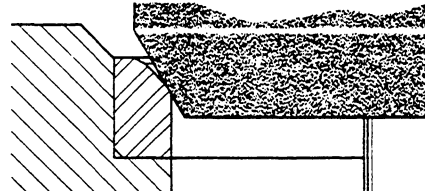

Check that valve head has not receded more than .005" below cylinder head surface.

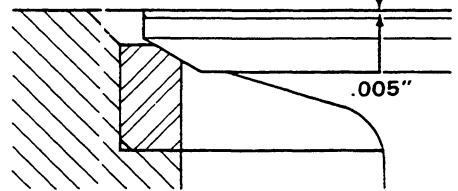

Check that valve head has not receded more than .005" below cylinder head surface.

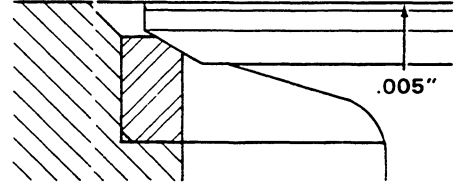

If valve head recedes or protrudes more than .005", refer to Steps 65 and 66.

---



**SEAT CONTACT AREA ON VALVE TOO HIGH**

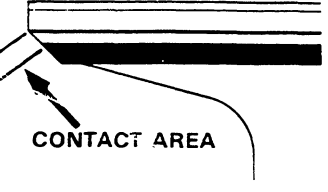

CONTACT AREA

If valve contact area on seat looks like this (previously ground seat).

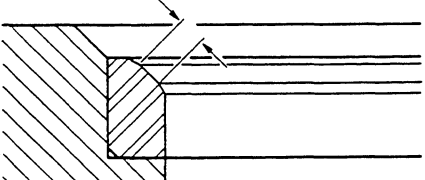

Use a 45° stone to lower and widen contact area

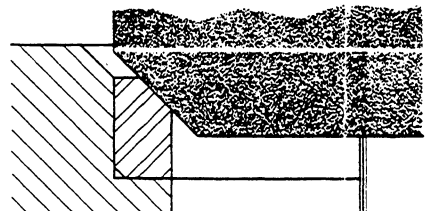

If valve contact area on seat looks like this.

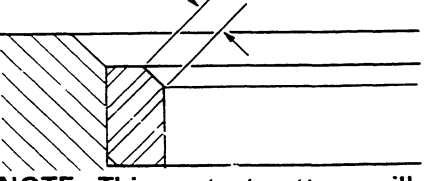

**NOTE:** This contact pattern will also be found on intake valves without replaceable seats.

The valve and valve seat must be replaced since additional grinding will not alter the lower contact point.

Use a 30° narrowing stone to narrow upper contact area increased by 45° stone

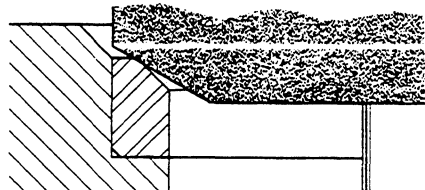

Check that valve head has not receded more than .005" below cylinder head surface.

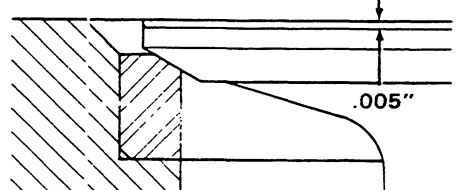

If valve head recedes or protrudes more than .005", refer to Steps 65 and 66.

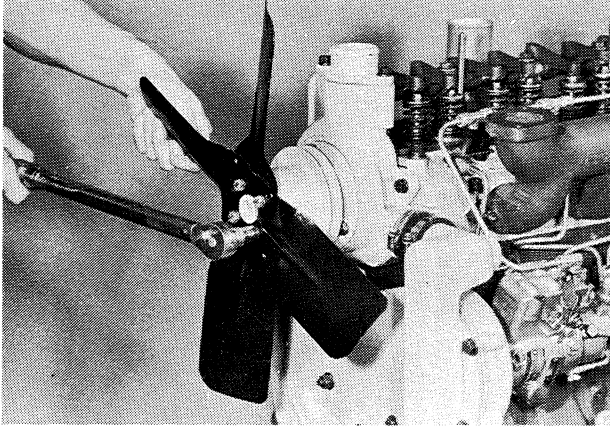
**STEP 105**

Install water pump, pulley, spacer (if equipped) and fan. Refer to Section 2055 for installation.

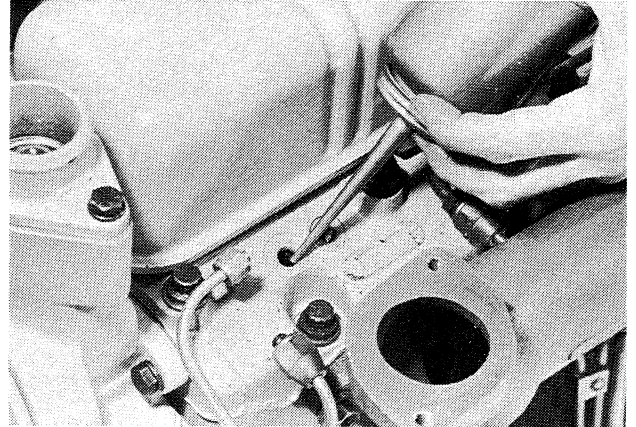
**STEP 106**

Install the fuel injectors. Refer to section 3013 for injector installation. *NOTE:* Squirt a few drops of HDM #30 oil in each cylinder head injector hole to provide lubricant for carbon dam at lower end of injector.

## Locating Top Dead Center

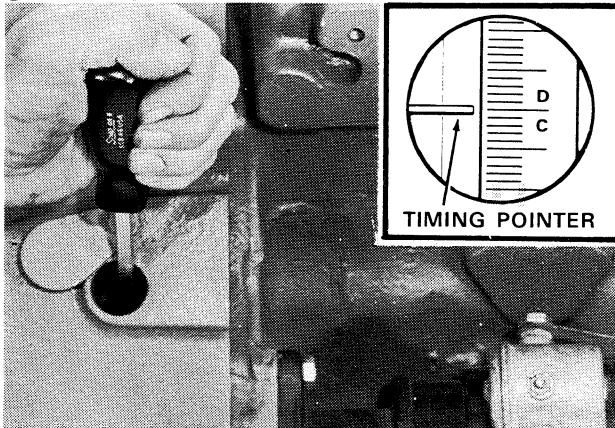
**STEP 107**

Crank the engine by inserting a screwdriver into the timing hole in the flywheel housing or torque tube and by engaging the ring gear teeth with the screwdriver, align the timing pointer with the TDC timing mark on the flywheel.

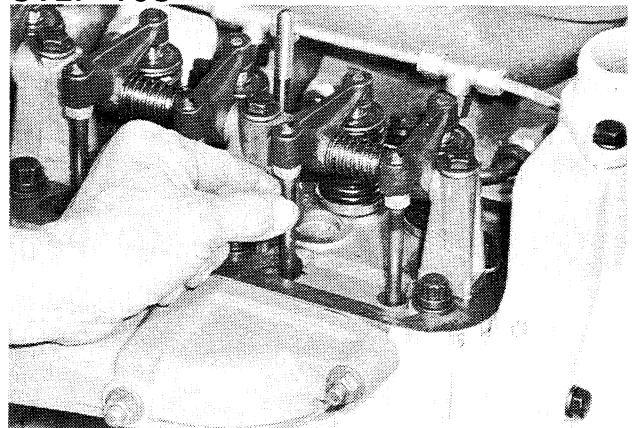
**STEP 108**

Check push rods on the number one cylinder for looseness. If push rods are loose, the number one cylinder is at TDC on the compression stroke. If push rods are tight, crank engine one complete revolution and align timing pointer with TDC mark on the flywheel.

## Front, Intermediate And Center Camshaft Bushing Replacement

### STEP 158

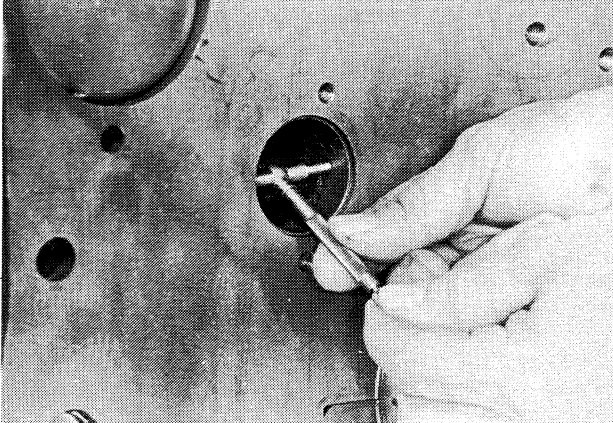

Using a bore gauge, measure the camshaft bushings. The bushing must be measured in two places. Take the second measurement 90° from the first measurement. *NOTE:* If bushing I.D. is greater than 1.755", replace the bushing.

### STEP 160

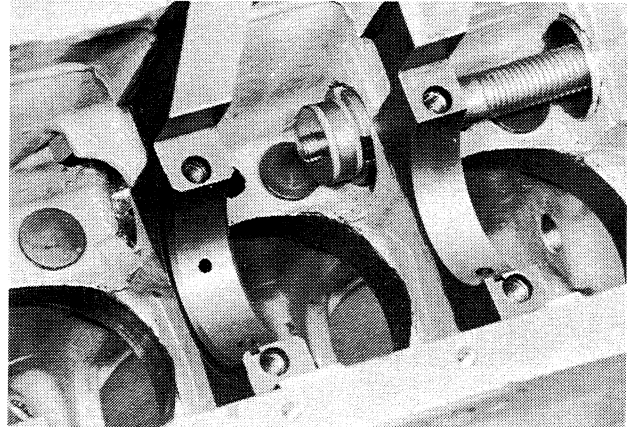

Puller installed in bushing to be removed.

### STEP 159

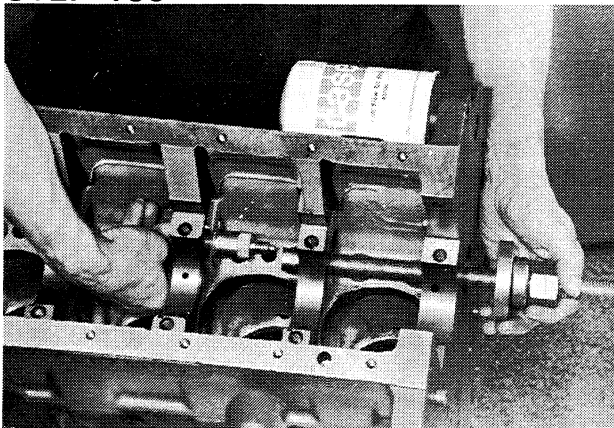

Insert bushing puller A41103 into the engine block to remove camshaft bushings. *NOTE:* The crankshaft, cylinder sleeves and pistons have been removed for photographic purposes only. These parts need not be removed when servicing camshaft.

**STEP 209**

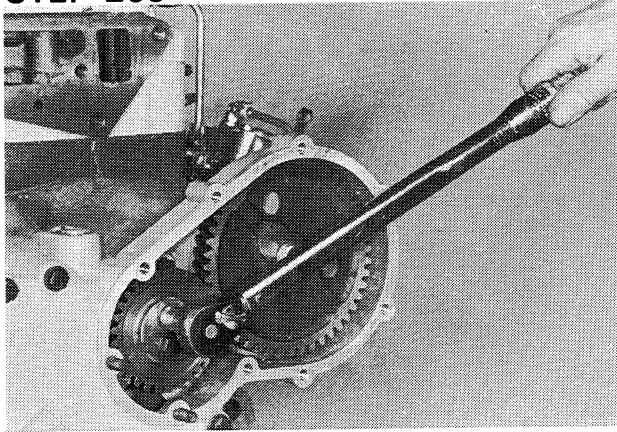

Torque idler gear retaining bolts 35 to 42 ft. lbs.

**STEP 211**

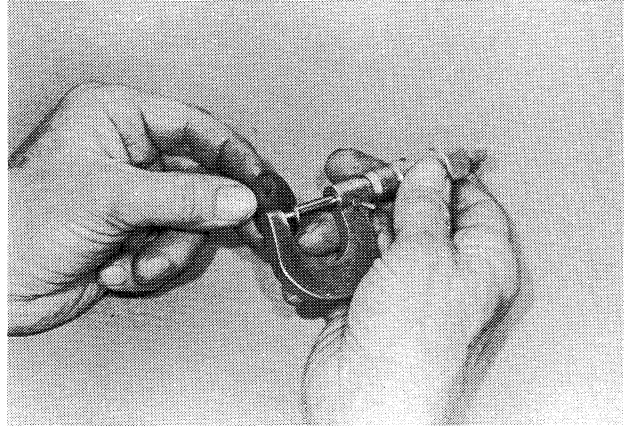

Remove mounting bolts and by measuring the thickness of the shims with a micrometer, add or deduct shims to obtain correct clearance.

**STEP 210**

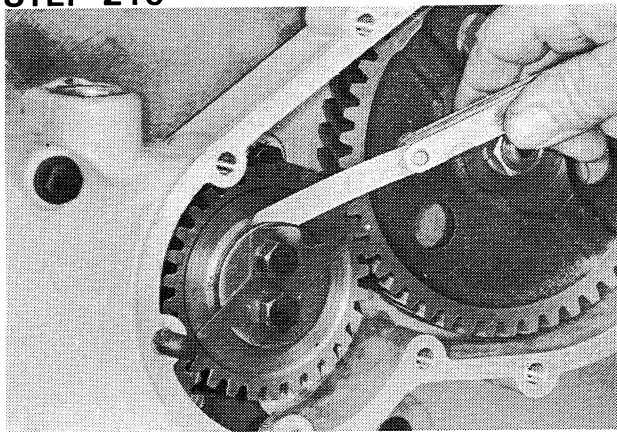

With a feeler gauge check the running clearance between thrust washer and idler gear. The running clearance should be .003".

**STEP 212**

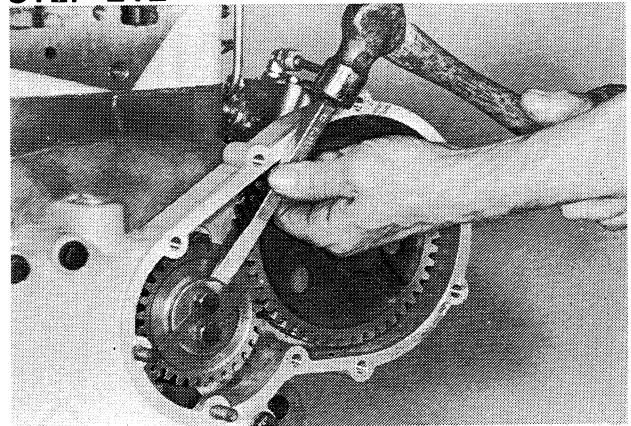

Reinstall mounting bolts in idler gear, torque 35 to 42 ft. lbs. Then bend lock plate over retaining bolts.

**STEP 213**

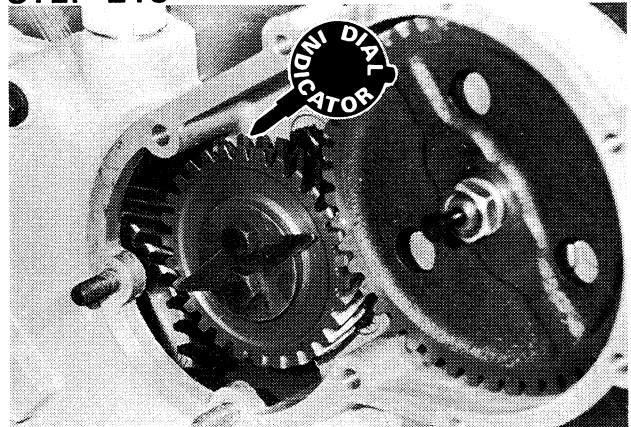

Take a screwdriver and hold cam gear so it can't move. Install a dial indicator to check back lash. Backlash must not exceed .006". If backlash exceeds .006", replace the gears.

## Cylinder Sleeve Inspection

### STEP 15

Inspect the cylinder sleeves for the following conditions.

#### NORMAL WEAR

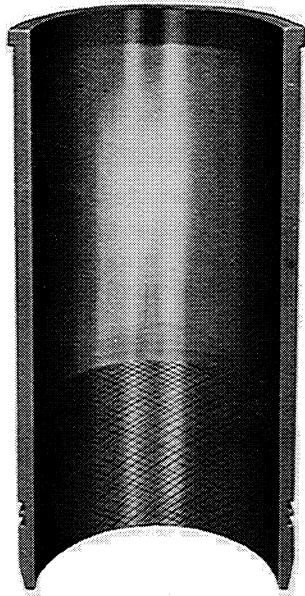

A smooth, shiny surface between the upper and lower limits of the ring travel indicates normal wear. There will always be slight wear present due to combustion pressure forcing the top ring outward against the cylinder sleeve.

Normal wear indicates satisfactory sleeve conditions and the sleeve need not be replaced.

### STEP 15 (CONT)

#### WORN OUT SLEEVE

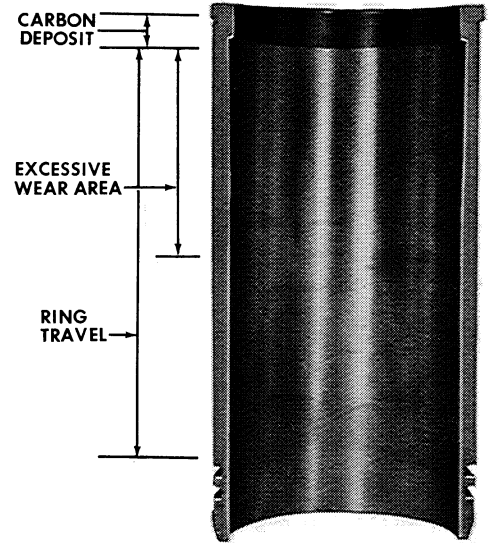

A smooth, shiny surface the complete length of the cylinder sleeve indicates a worn out sleeve due to normal wear and it should be replaced.

#### SCUFFED CYLINDER WALLS

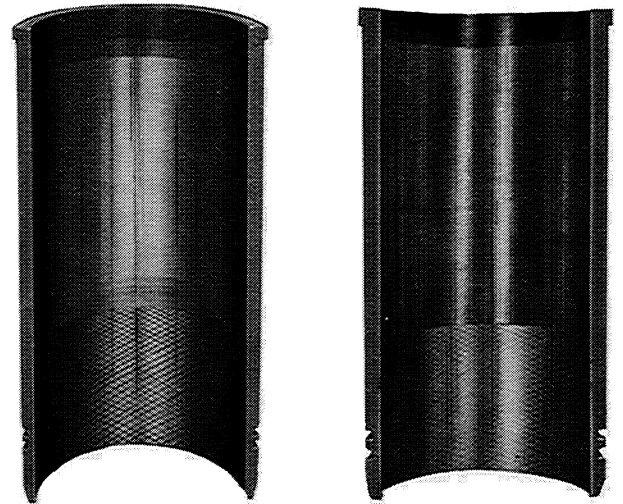

Heavy vertical lines fringed by a discolored band caused by metal transferring from one spot to another indicates scuffed cylinder walls. The vertical scuff marks are caused by metal coming in contact with the piston. The scuffing may be in one particular area or it may occur the entire length of the piston travel.

If this condition exists, replace the cylinder sleeve.

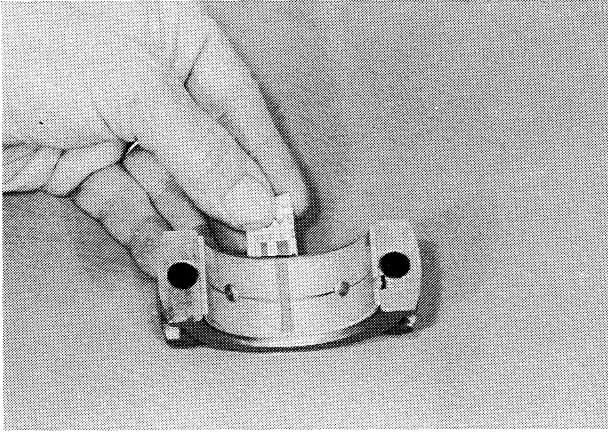
**STEP 61**

Remove bearing cap from connecting rod. The flattened plasti gauge will be found on either the rod bearing cap or crankshaft. Compare the flattened gauge material at its widest point with the scale that is furnished. The number within the graduation indicates the clearance in thousandths of an inch. The clearance must be .0010" to .0040". If clearance exceeds the specified limit, undersize bearing liners must be installed to provide the proper clearance. Refer to Detailed Specifications Section.

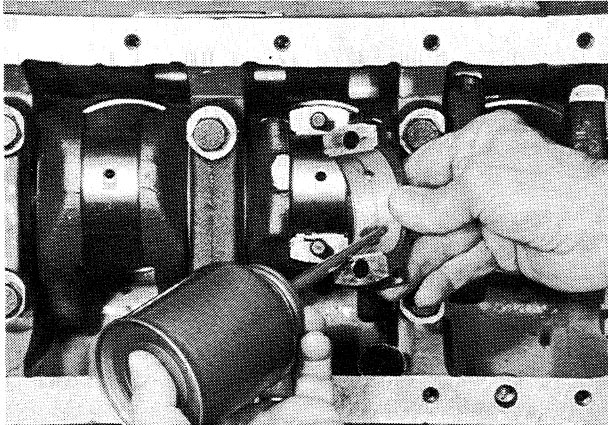
**STEP 62**

Lubricate connecting rod bearing cap liners and rod journals with HDM No. 30 oil.

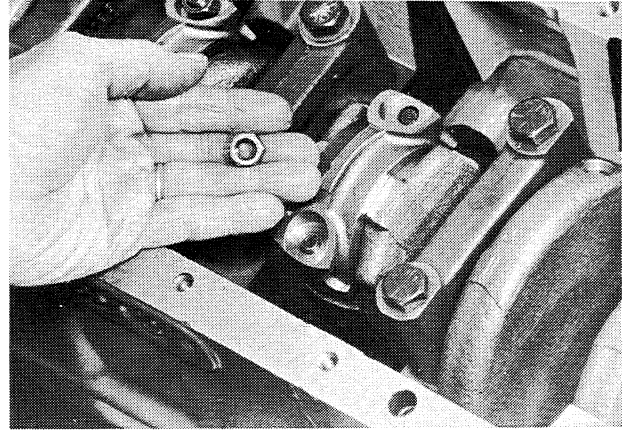
**STEP 63**

Reinstall connecting rod bearing caps and mounting nuts. Be sure numbered sides of cap and rod are together.

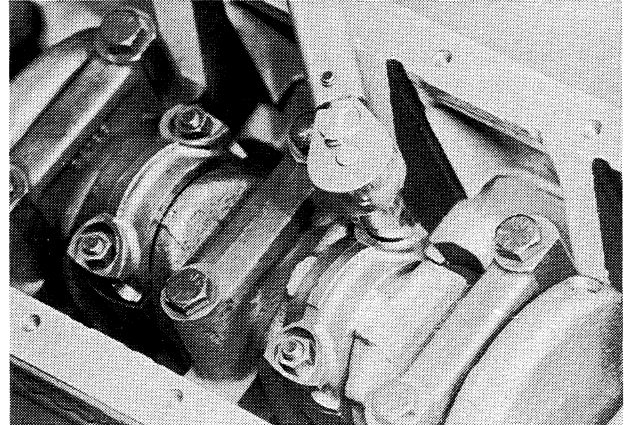
**STEP 64**

Torque connecting rod bearing cap mounting nuts 45 to 50 ft. lbs.

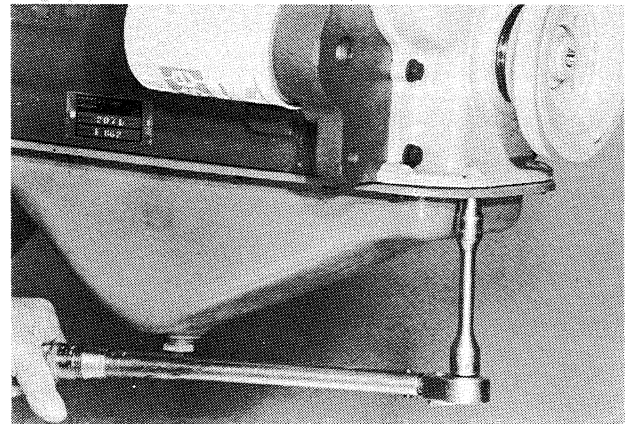
**STEP 65**

Install oil pan and gasket. Torque stamped steel oil pan mounting bolts 10 to 12 ft. lbs.

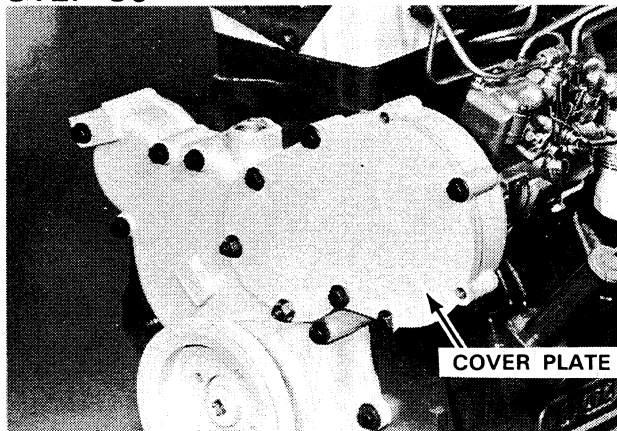
**STEP 36**

Remove cover plate from timing gear cover.

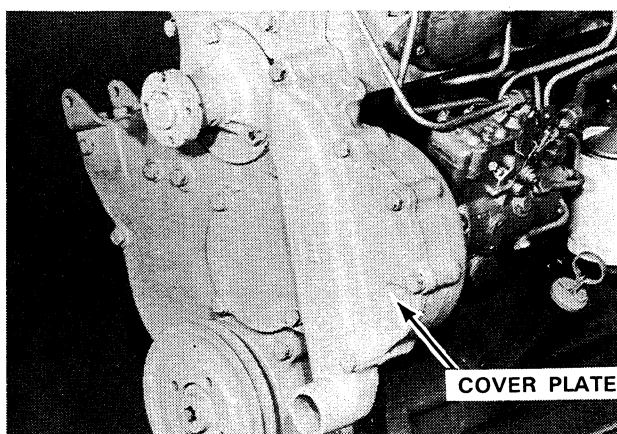

*If equipped,* remove timing gear cover plate with integral water tube.

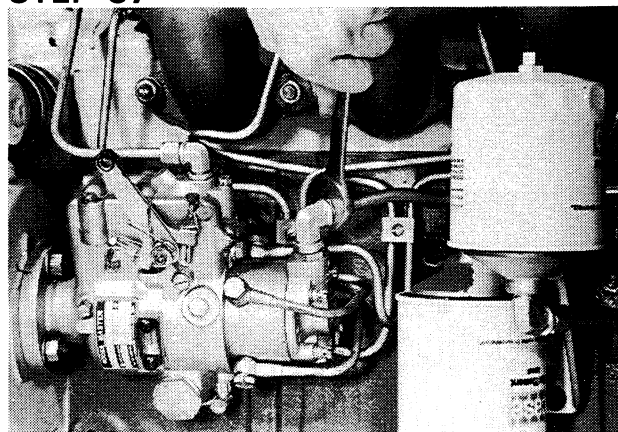
**STEP 37**

Disconnect the inlet fitting, leakoff line, throttle control and governor control from fuel injection pump. Disconnect the high pressure lines from the fuel injectors.

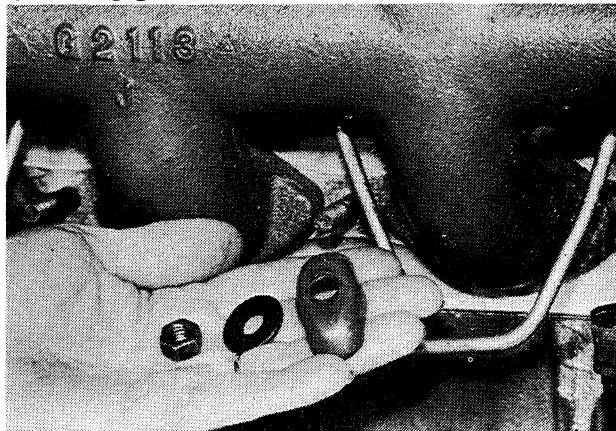
**STEP 38**

Remove the manifold stud nuts, washers and retaining clamps.

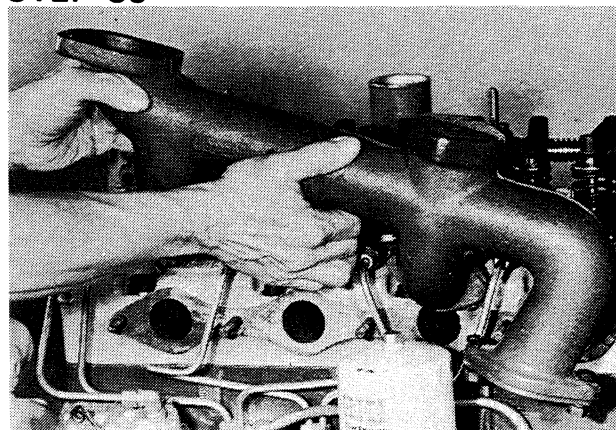
**STEP 39**

Remove the front of the manifold off of the front stud. Swing manifold upward and remove the manifold from the rear stud.

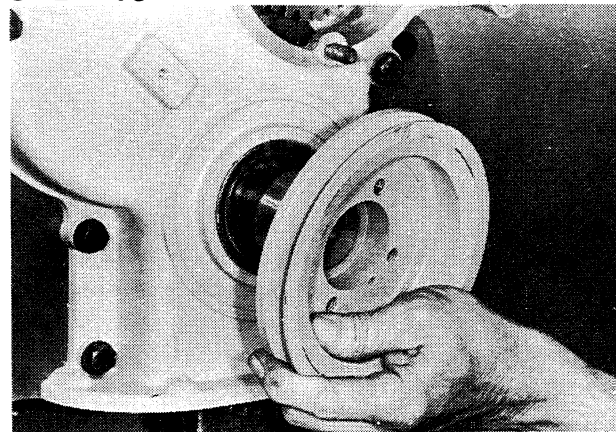
**STEP 40**

Remove crankshaft pulley.

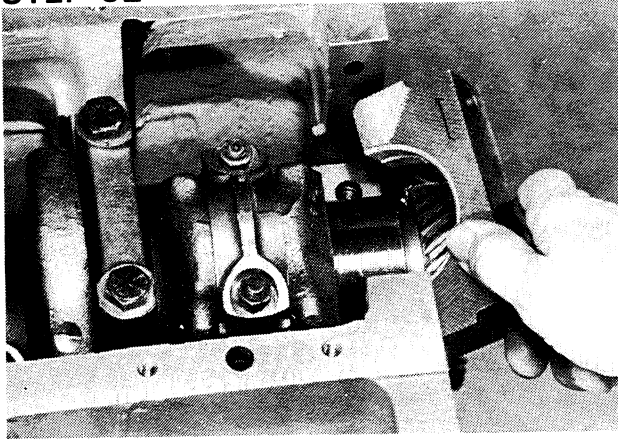
**STEP 92**

Install front main bearing cap in engine block.

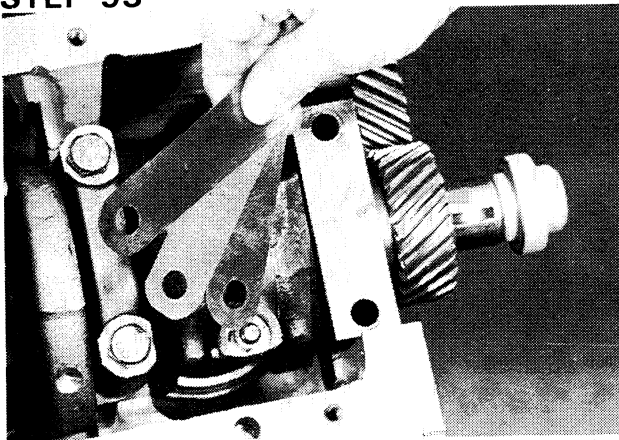
**STEP 93**

Install enough number of shims on the front main bearing cap to maintain backlash between pump gear and crankshaft gear when mounting bolts are torqued, or damage to the oil pump may result.

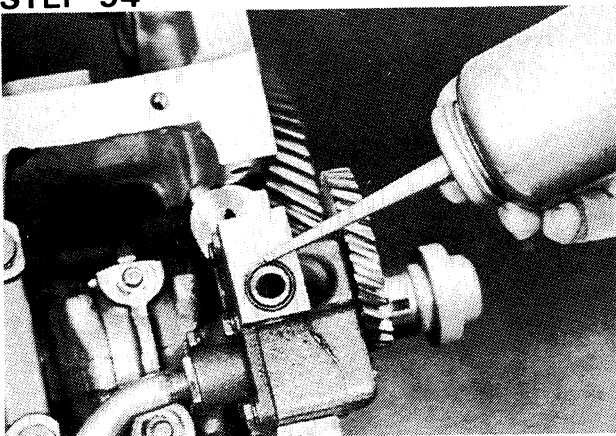
**STEP 94**

Install new "O" ring seal, in oil pump and lubricate with clean HDM No. 30 oil.

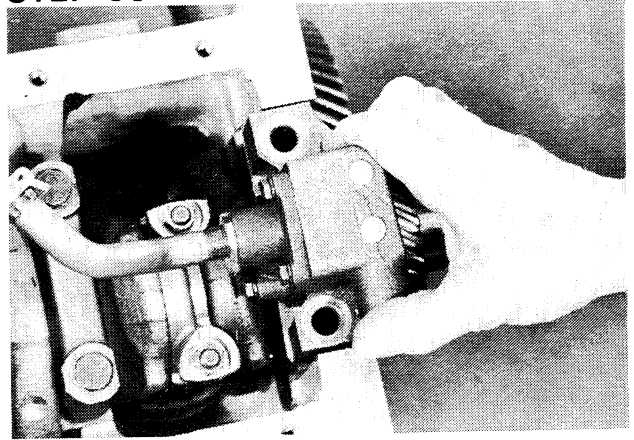
**STEP 95**

Install oil pump in engine block. **IMPORTANT:** Care must be taken not to cut "O" ring when installing pump to engine.

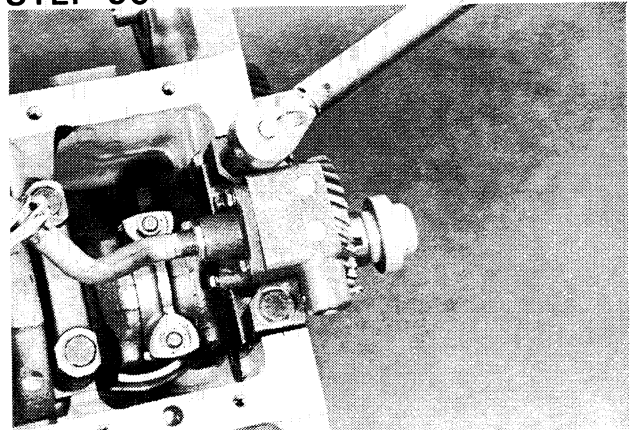
**STEP 96**

Torque the oil pump mounting bolts 90 to 100 ft. lbs. **IMPORTANT:** A repeated check for backlash between the pump gear and crankshaft gear should be taken when bolts are torqued, or damage to the oil pump may result.

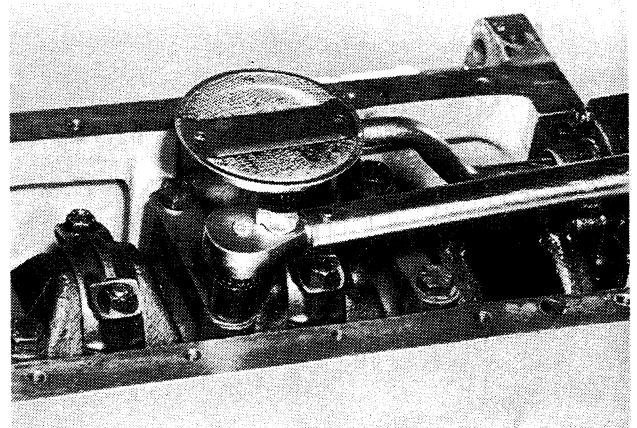

*If equipped,* torque the suction tube bracket mounting bolts 90 to 100 ft. lbs.

# OIL PUMP

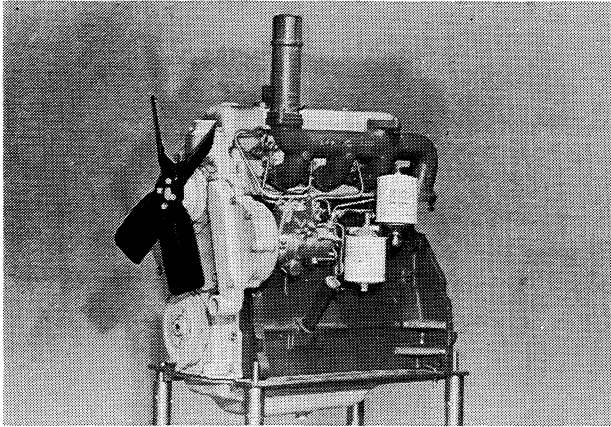

188 DIESEL ENGINE

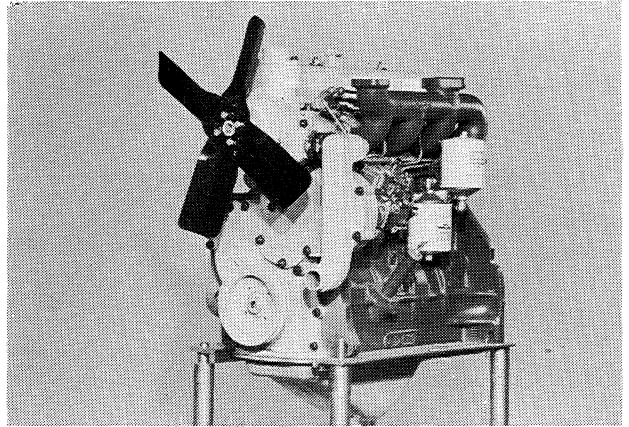

207 DIESEL ENGINE

## Oil Pump Removal

### STEP 1

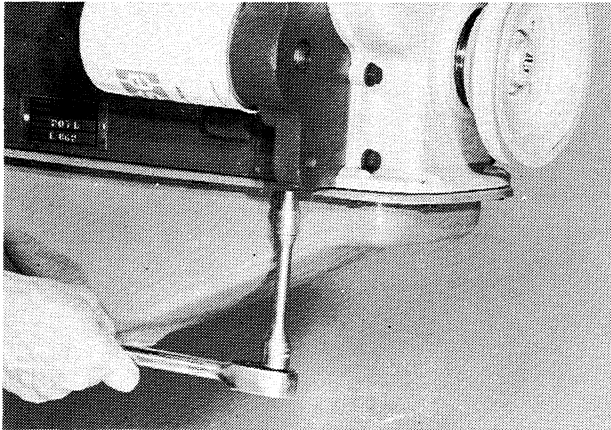

Remove oil pan drain plug and drain oil from engine. Remove oil pan mounting bolts.

### STEP 2

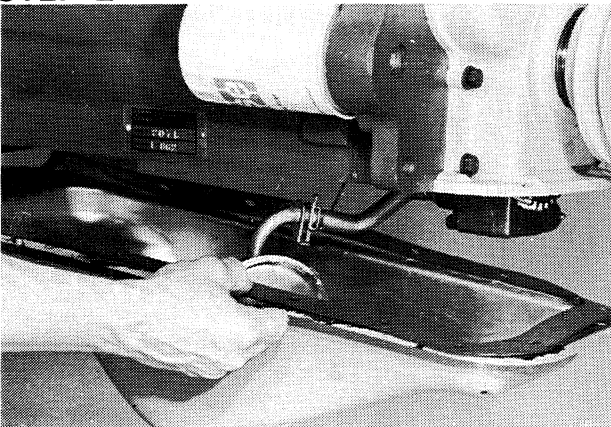

Remove oil pan and gasket from engine.

### STEP 3

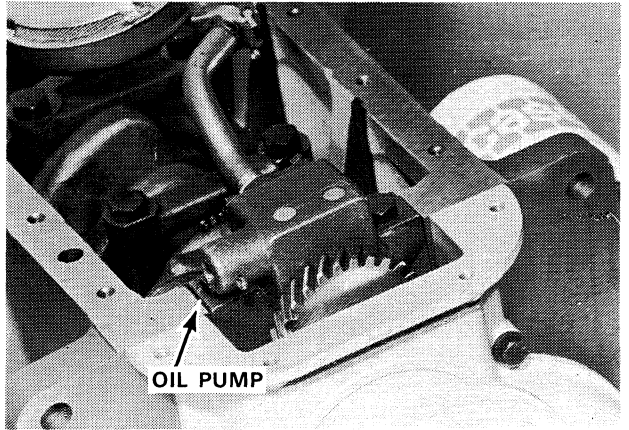

OIL PUMP

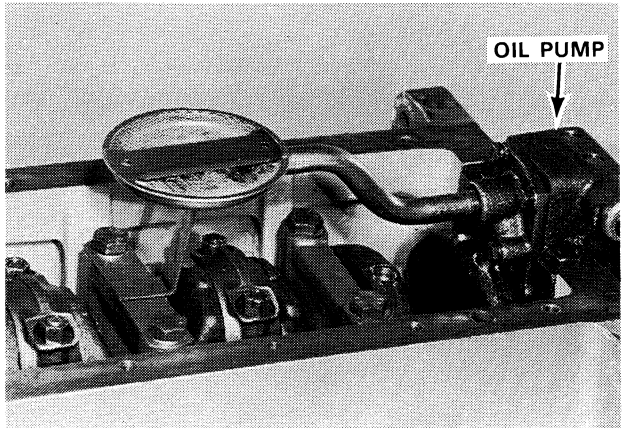

OIL PUMP

Oil pan removed from engine.

# **Section 2055**

**COOLING SYSTEM**

**188 and 207 Diesel Engines**

**Thermostat and Water Pump**

## ENGINE OIL PUMP FLOW

### STEP 3

As the oil pressure builds up within the engine oil galleries, the pressure is sensed at the pump. This pressure is then exerted on the back side of the pressure regulator sleeve. As pressure builds up to 50 to 75 PSI, the regulator sleeve is moved, opening an internal passage to the inlet side of the pump cavity.

Should the oil pressure drop below 50 to 75 PSI, the regulator spring moves the sleeve back, closing off the passage to the inlet side the pump cavity.

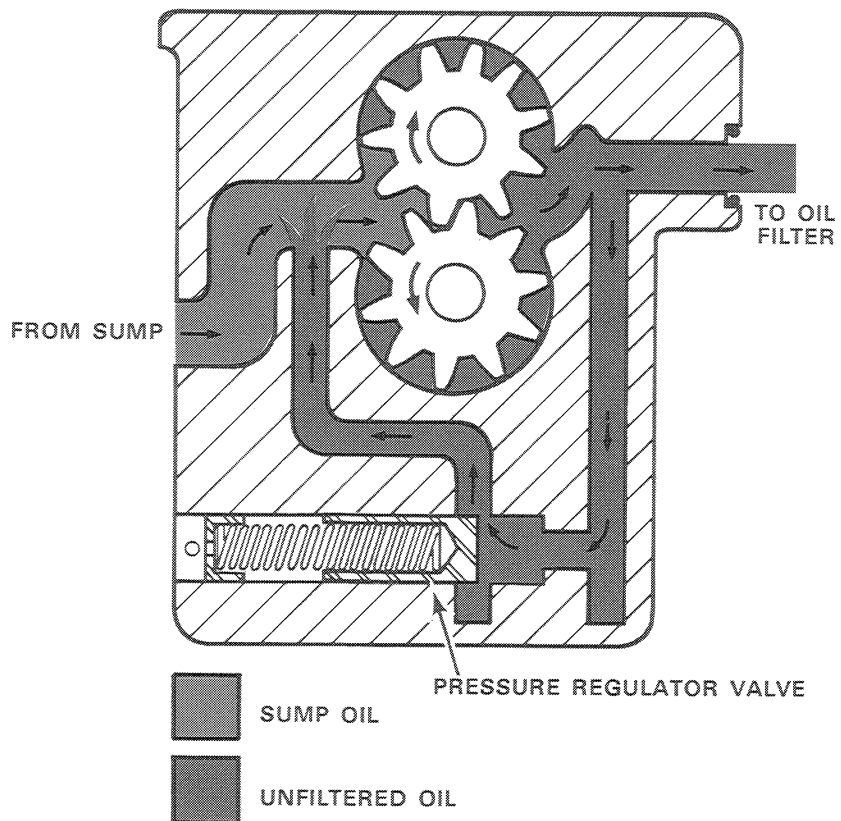

**STEP 9**

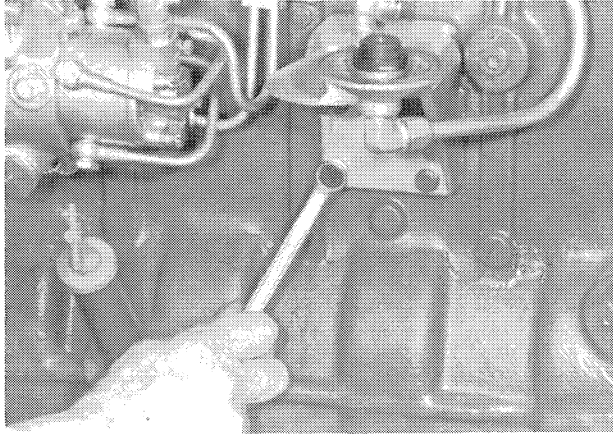

Remove filter head mounting bolts.

**STEP 12**

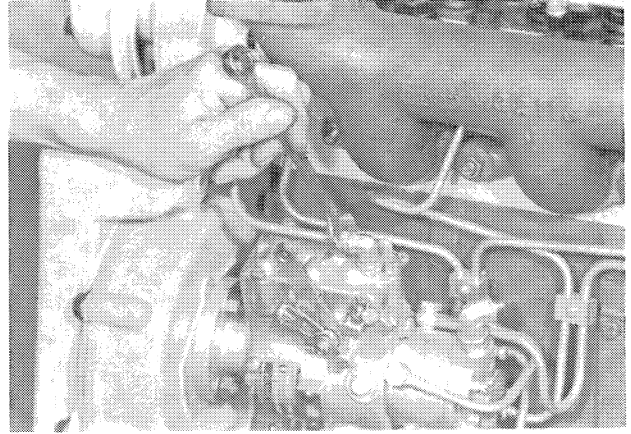

Disconnect leakoff return line from pump.

**STEP 10**

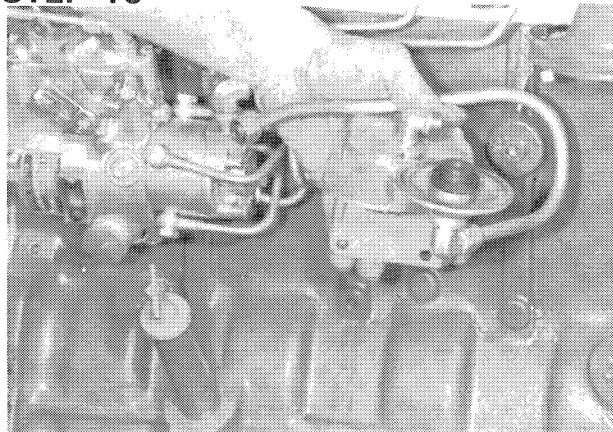

Remove filter head from engine block.

**STEP 13**

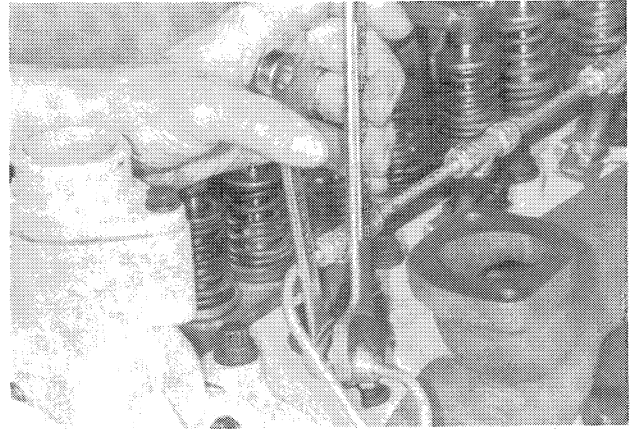

Disconnect high pressure lines from fuel injectors using the one hand-two wrench method.

**STEP 11**

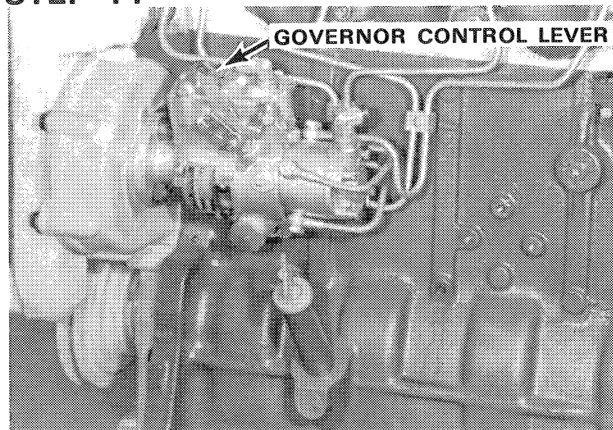

Disconnect the throttle rod from the governor control lever and the fuel shutoff cable from the shutoff lever.

**STEP 69**

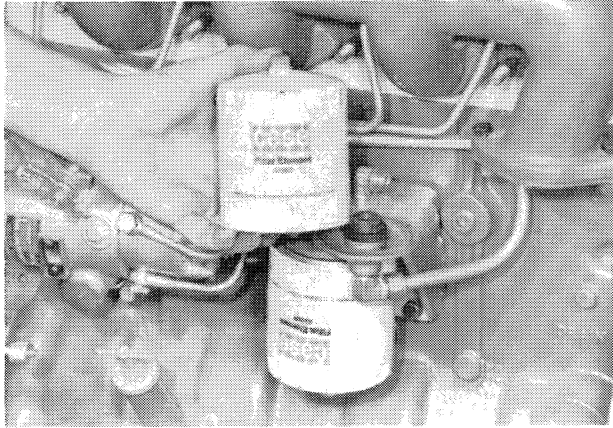

Install primary and final fuel filters on filter head. Refer to Section 3010.

**STEP 72**

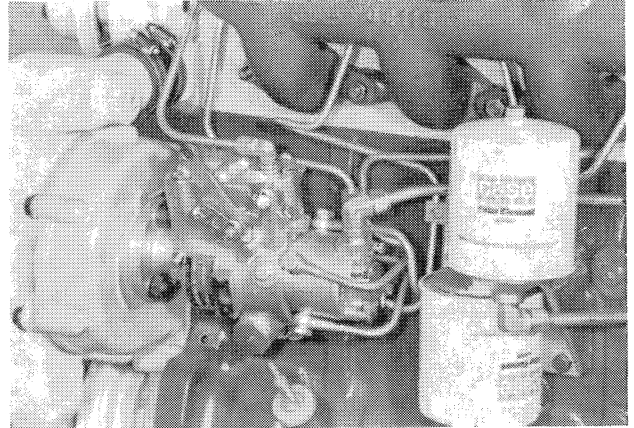

Fuel pump installed.

**STEP 70**

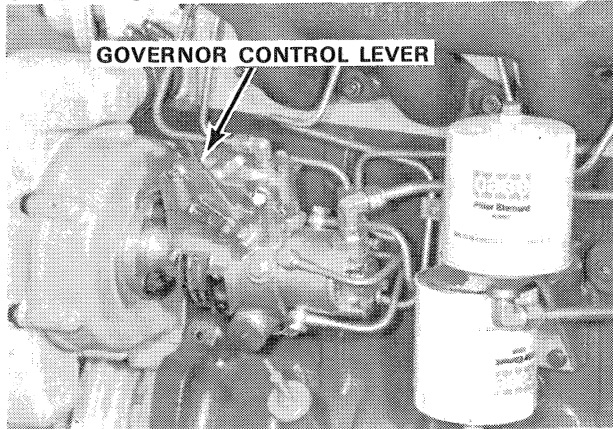

Connect the throttle rod to the governor control lever and the fuel shutoff cable to the shut-off lever.

**STEP 73**

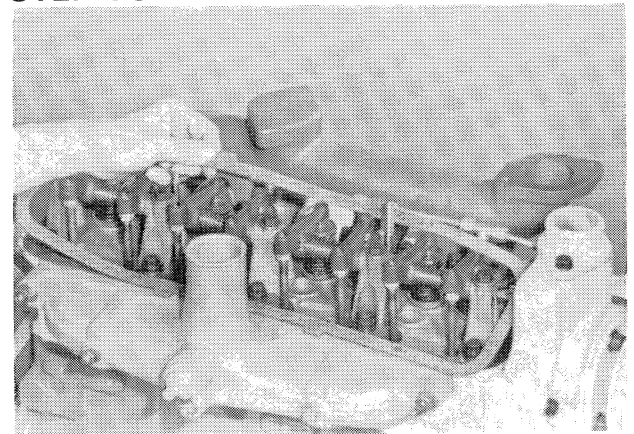

Install valve cover gasket.

**STEP 71**

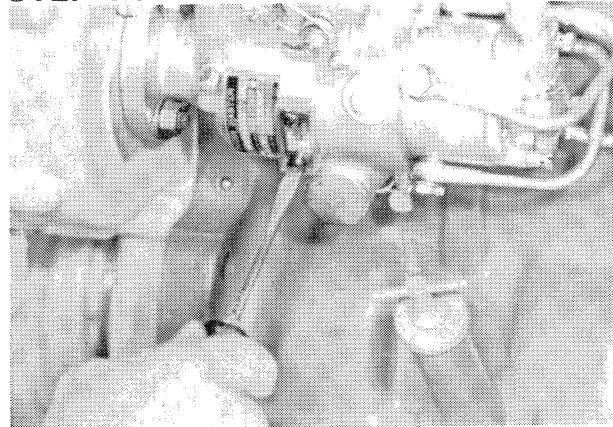

Install timing window cover on injection pump. Refer to Page 21 and check pump gear to idler gear backlash.

**STEP 74**

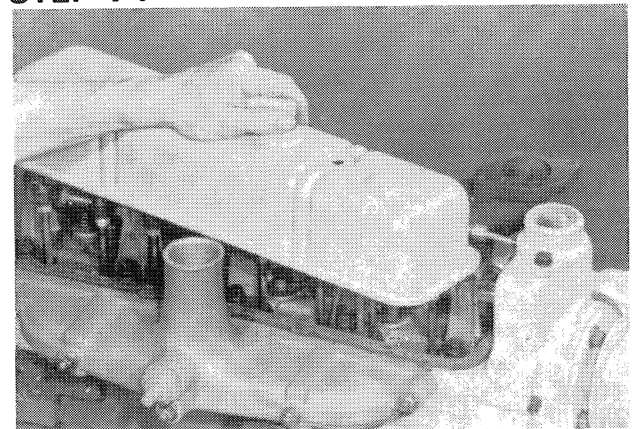

Install valve cover.

## SPECIAL TOOLS

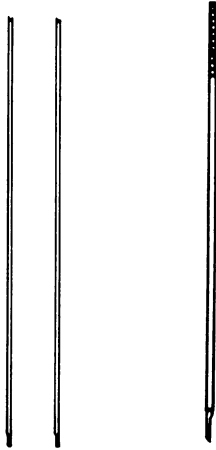

SAC HOLE  
DRILLS  
SET OF 5  
.010"  
66-0151

TIP SEAT  
SCRAPER  
66-0149

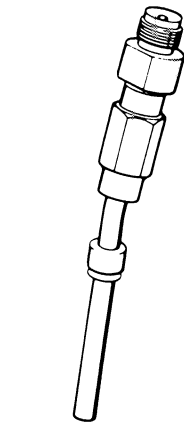

COMPRESSION  
GAUGE ADAPTER  
70-314 (D558)



TORQUE  
WRENCH  
ADAPTER  
66-0146



VALVE  
RETRACTOR  
66-0148



ORIFICE  
CLEANING WIRES  
66-0036



SEAL TOOL  
CASE PART  
A42449

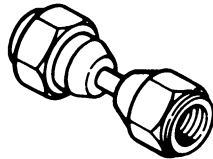

TEST PUMP ADAPTER  
65-878 (N49)



LAPPING  
COMPOUND  
66-0145

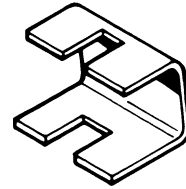

INJECTOR  
HOLDING TOOL  
66-0147



MAGNIFYING GLASS  
66-0135

### TOOLS IN CASE KIT NO. M20520

The individual parts can be ordered from the Bacharach Inst. Co.  
200 N. Braddock Ave., Pittsburgh, Pa. 15208.

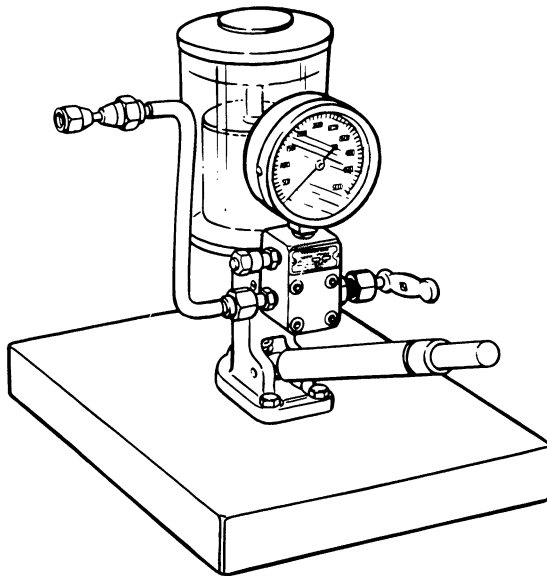

TEST STAND  
CASE PART NO. M20322  
BACHARACH PART NO. 65-934D



NOZZLE PULLING TOOL  
CASE PART NO. A43278



BORE CLEANING TOOL  
CASE PART NO. A43277

**NOTE:** Injector Tool Kit, Case Part No. M20520, Bacharach Part No. 60-0010. This kit is used in conjunction with the Case Diesel Tool Kits, Case Part No. M20247 (CD-800) and Case Part No. M20246 (CD-350).

## TESTING INJECTORS (Continued)

### Spray Pattern

Close the pressure gauge. Operate the tester at 60 strokes per minute and observe the spray pattern. Fuel should be finely atomized and not a solid irregular spray pattern.

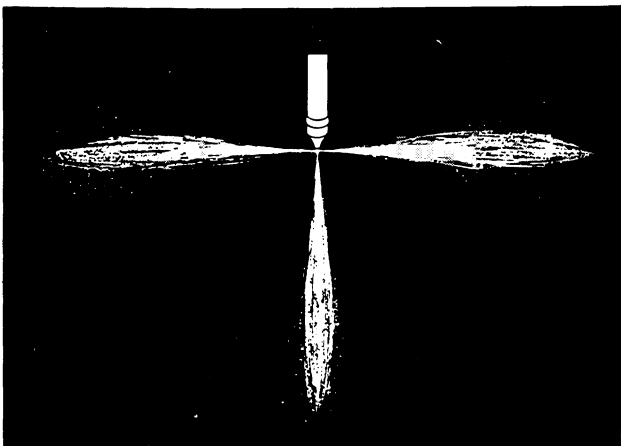

Fine Atomized Spray Pattern

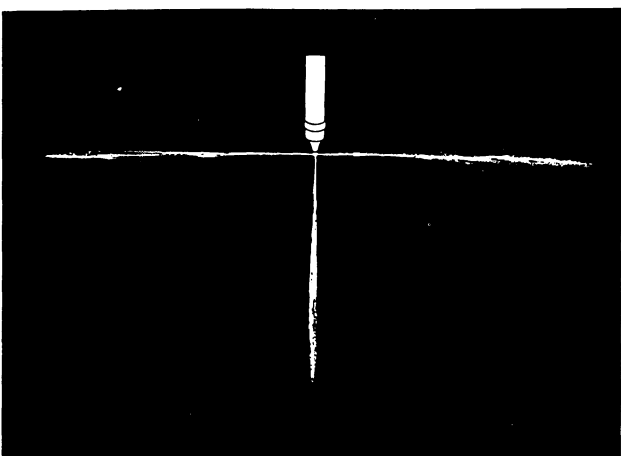

Solid Type Irregular Spray Pattern

The injector will chatter when the tester is operated rapidly. Although this chatter may not occur in operation of the injector in the engine, it is an indication of valve freedom and will improve atomization. Chatter is generally an indication of good seat width and interference angle conditions.

**If the injector produces a solid type irregular spray pattern, proceed as follows:**

1. Check for eroded, clogged or chipped orifices. See Page 18.
2. Disassemble and clean injector, See Pages 16 through 21.
3. Lap the valve to guide area. See Pages 18 and 19.
4. Check for pitted or eroded valve or seat, valve interference angle worn, bent valve and distorted body. These conditions would require replacement of the complete injector assembly.

### Injector Leak-Off

Loosen connector nuts and reposition injector tip slightly above a horizontal plane. Tighten connector nuts and raise pressure to 1500 PSI. Observe leakage from the return end of the injector. After one drop falls, leak-off should be 3 to 10 drops in 30 seconds with No. 2 diesel fuel at room temperature (65°-75°F.).

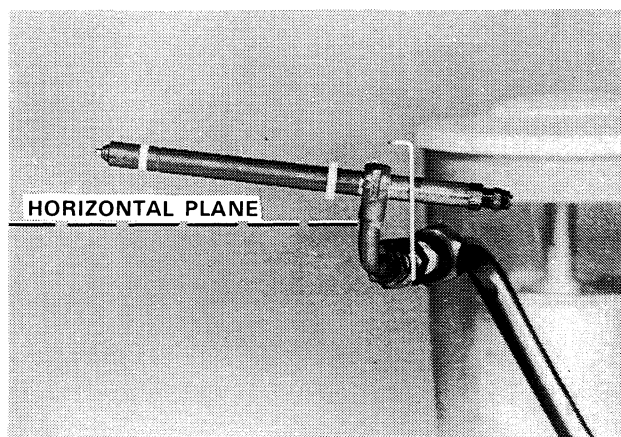

If the leak-off does not meet this specification, proceed as follows:

1. If excessive leak-off is noted, injector must be replaced.
2. If low leak-off is noted, disassemble and clean injector. See Pages 16 through 18.
3. Lap the valve to guide area to increase the nozzle leak-off. See Pages 18 and 19.

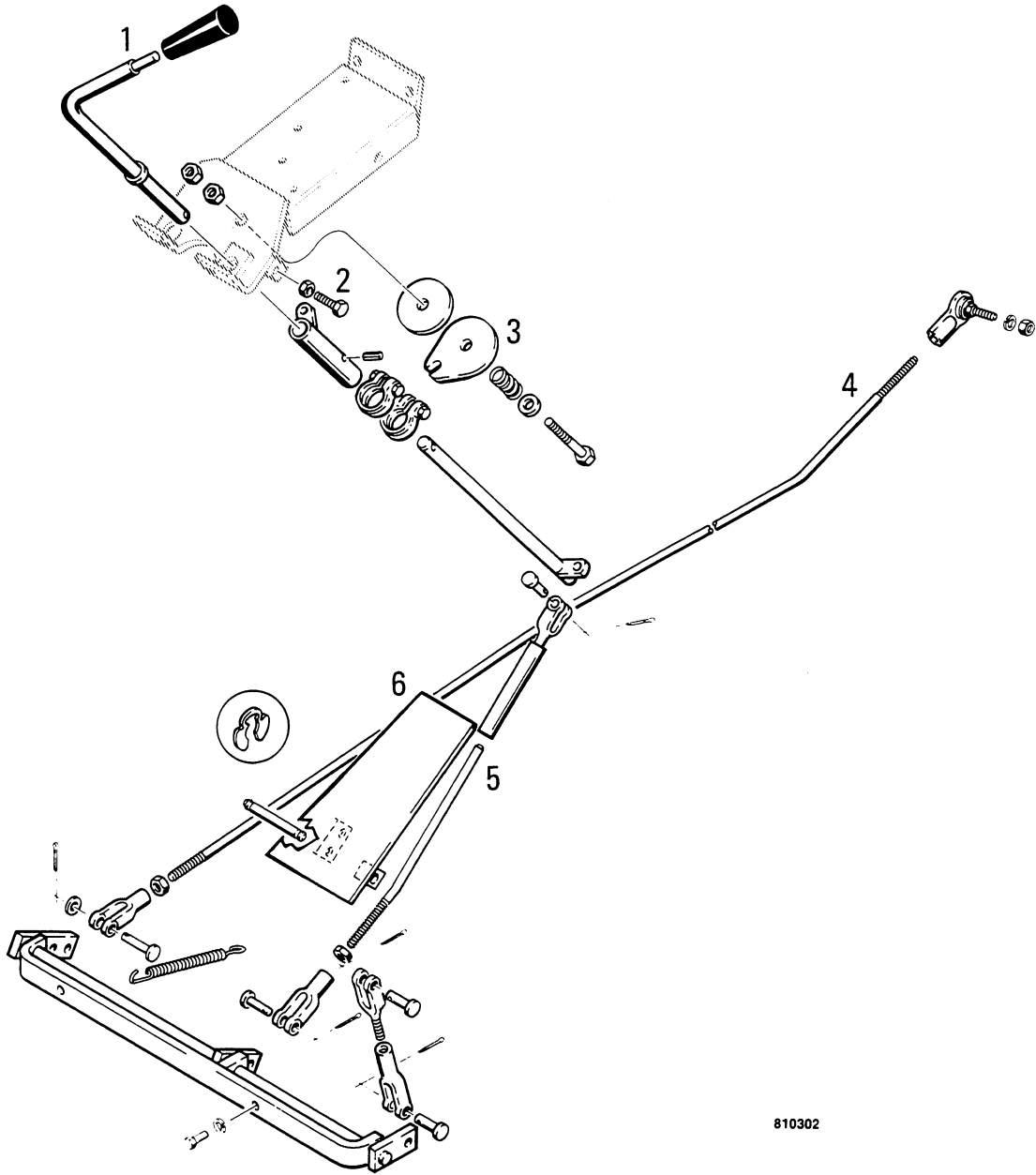

810302

1. HAND THROTTLE  
2. STOP BOLT

3. FRICTION DISC ASSEMBLY  
4. THROTTLE ROD

5. HAND THROTTLE ROD  
6. ACCELERATOR

Figure 1

- Select the voltmeter range that will measure 16 volts.

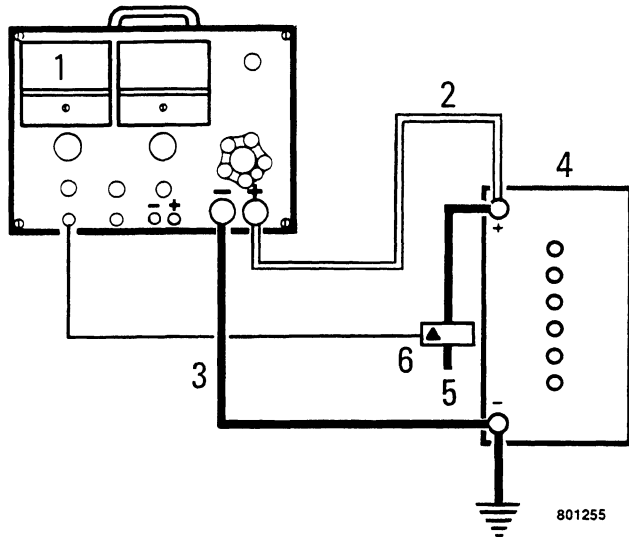

- AMMETER
- POSITIVE LOAD LEAD
- NEGATIVE LOAD LEAD
- 12 VOLT BATTERY
- CONNECTED TO STARTER
- AMMETER CLAMP

Figure 3

- Connect the positive load lead to the connection for the positive battery cable at the battery.
- Connect the negative load lead to the connection for the negative battery cable at the battery.
- Fasten the ammeter clamp around the positive battery cable. Be sure the point of the arrow on the ammeter clamp is toward the battery.
- Start the engine. Run the engine at approximately 1200 rpm (r/min).
- Adjust the load control to get maximum ammeter indication. Make a record of the ammeter indication.
 

**NOTE:** Do not apply a load to the battery for more than 15 seconds at one time. After 15 seconds, put the load control in the Off position for at least 60 seconds before applying the load again.
- Put the load control in the Off position.

- Stop the engine.
- The ammeter indication in step 9 must be 32 to 42 amperes.
  - If the ammeter indication was correct, the alternator and voltage regulator are good.
  - If the ammeter indication was less than 32 amperes, go to step 13.
- Start the engine. Run the engine at approximately 1200 rpm (r/min).
- Put a screwdriver in the test hole in the rear housing as shown in Figure 4. There is a tab approximately 5/8 inch (16 mm) behind the test hole. Hold the screwdriver in contact with the tab and the housing.

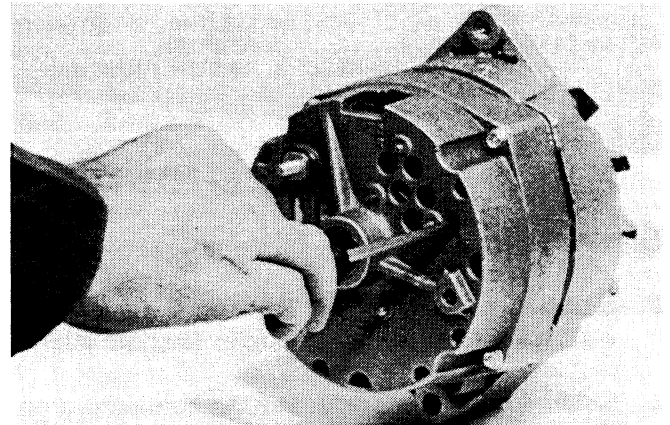
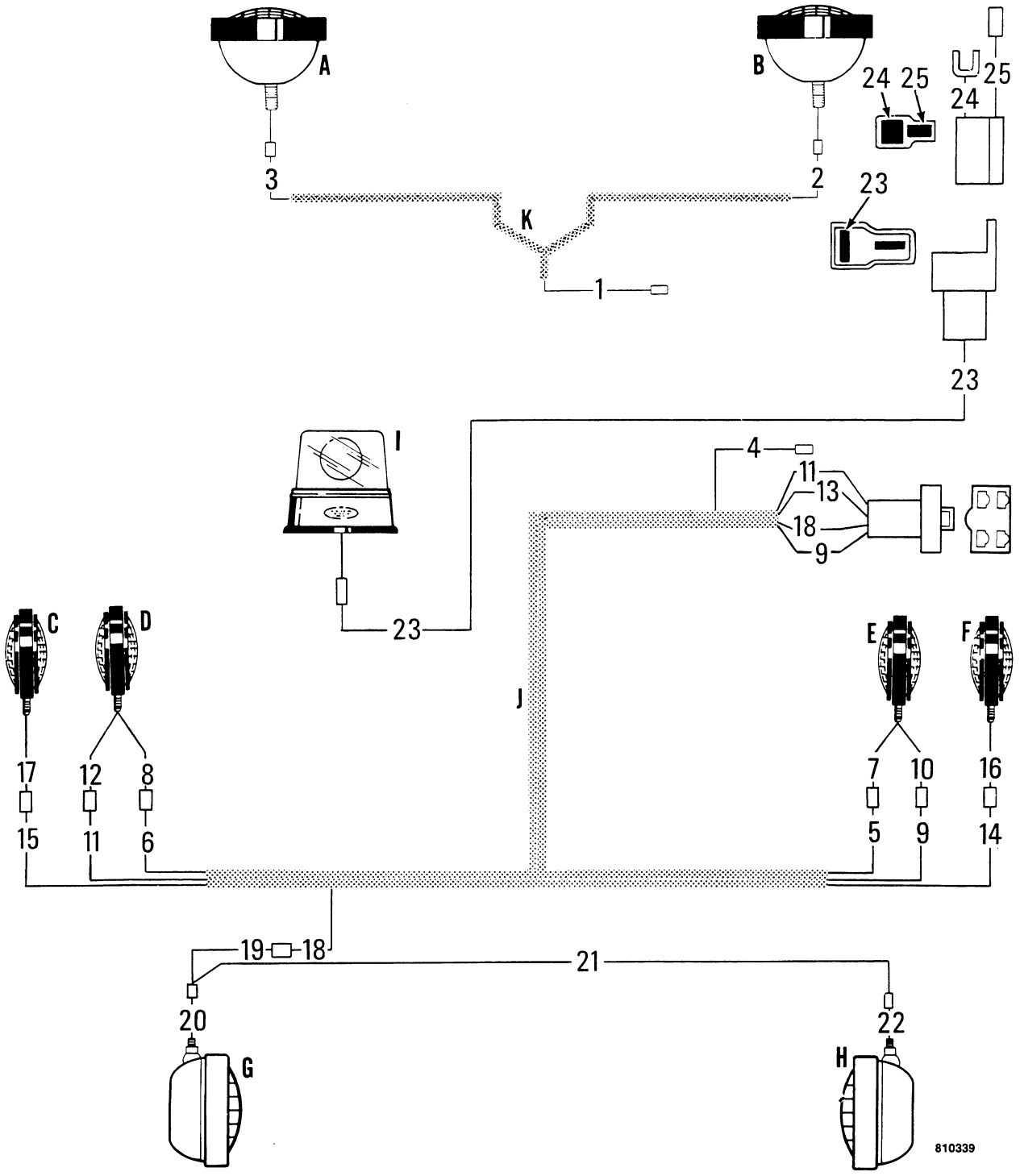

Figure 4

- Adjust the load control on the tester to get maximum ammeter indication. Make a record of the ammeter indication. Put the load control in the Off position.
- Stop the engine.
- If the ammeter indication in step 15 is between 32 and 42 amperes, the voltage regulator must be replaced. It is important to do the rotor tests in Section 4007 to be sure the rotor is not damaged.
- If the ammeter indication in step 15 is less than 32 amperes, the alternator must be disassembled and the component parts checked using the instructions in Section 4007.



810339

Figure 3 - Canopy with Turn Signal Lamps

## BATTERY TESTS

### Visual Checks

Check for cracks or other damage in the battery case, the battery cover, and the battery posts. If you find damage, discard the battery.

Check the electrolyte level according to the instructions under Electrolyte Level in this section. If you add water, remove the nonspill caps, then charge the battery for 15 minutes at 15 - 25 amperes to mix the water with the electrolyte. The water and electrolyte must be completely mixed before additional testing is done.

Check for electrolyte and foreign material on the top of the battery. If you find any electrolyte or foreign material on the top of the battery, clean the battery according to the instructions under Procedure to Clean the Battery in this section. Electrolyte and foreign material on the battery can cause battery test results which are not accurate.

### Specific Gravity Check

#### Procedure

Use a hydrometer to check the specific gravity (weight) of the electrolyte. The specific gravity shows the approximate level of charge of the battery.

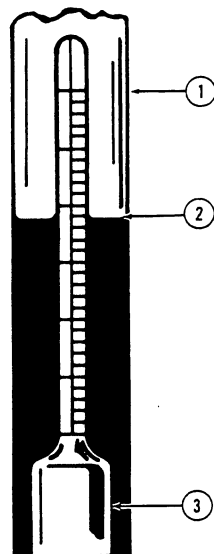

1. HOLD HYDROMETER VERTICAL
2. READ AT EYE LEVEL
3. FLOAT MUST BE FREE

Figure 1 - Checking Specific Gravity

Hydrometers are made to show the correct specific gravity when the temperature of the electrolyte is 80° F (26.7° C). When you check the specific gravity, you must know the temperature of the electrolyte. If your hydrometer does not have a thermometer, get a thermometer to check the temperature of the electrolyte.

1. Use the hydrometer to remove electrolyte from one cell. Make a record of the specific gravity shown by the hydrometer.
2. Check the temperature of the electrolyte. See Figure 2 and adjust the specific gravity reading as follows:
  - a. Fahrenheit: Add .004 for each 10° F above 80° F. Subtract .004 for each 10° F below 80° F.
  - b. Celsius: Add .007 for each 10° C above (26.7° C). Subtract .007 for each 10° C below (26.7° C).
3. Repeat step 1 and step 2 for the other cells.

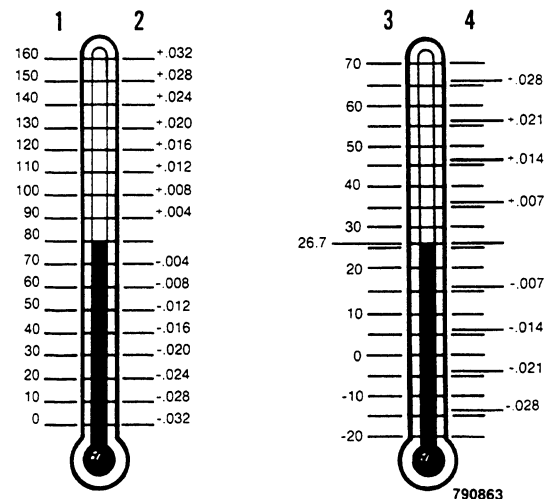

1. TEMPERATURE IN ° F
2. GRAVITY POINTS TO ADD OR SUBTRACT FROM HYDROMETER READING FOR EVERY 10° F ABOVE OR BELOW 80° F.
3. TEMPERATURE IN ° C
4. GRAVITY POINTS TO ADD OR SUBTRACT FROM HYDROMETER READING FOR EVERY 10° C ABOVE OR BELOW 26.7° C

Figure 2

9. Pull the field frame from the drive housing and the armature.

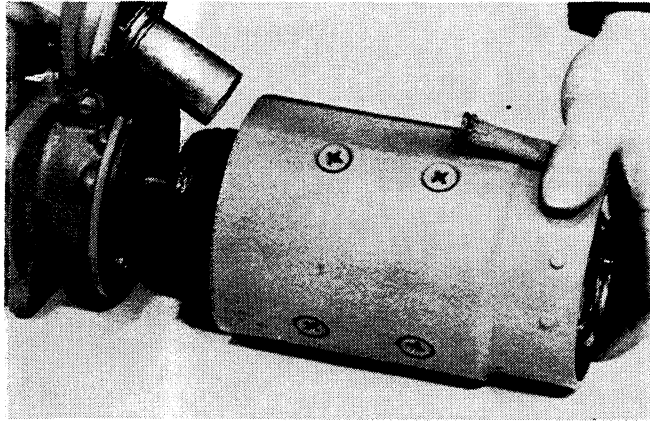
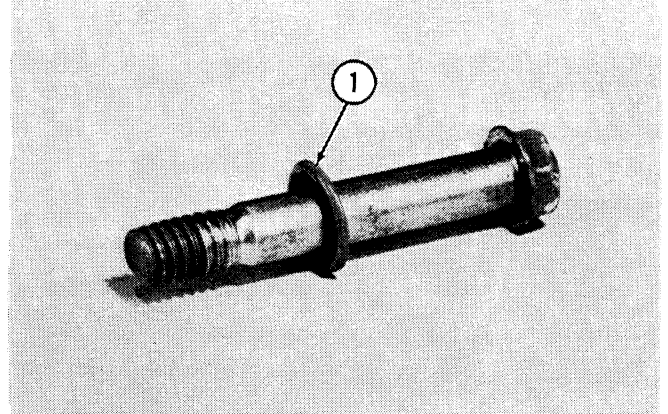

Figure 11

12. Remove the seal from the pivot bolt.



1. Seal

Figure 14

10. Remove the nut and lock washer from the pivot bolt for the shift lever.

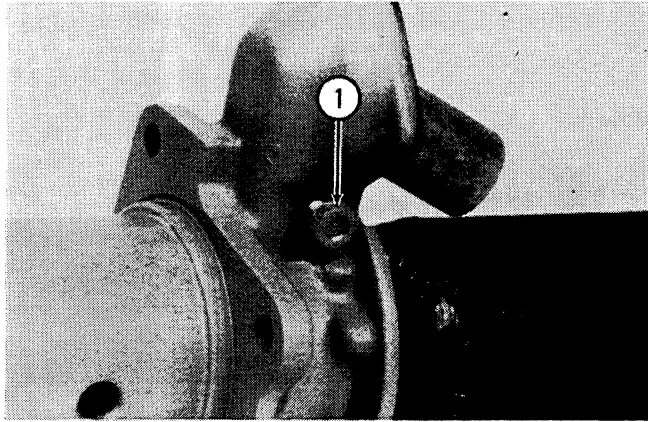

1. Nut and Lock Washer  
Figure 12

13. Remove the two cap screws and lock washers which fasten the center bearing plate to the drive housing.

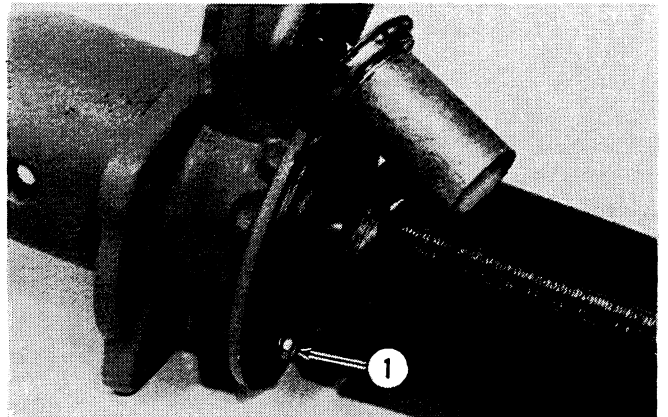

1. Cap Screw

Figure 15

11. Remove the pivot bolt and the seal from the drive housing.

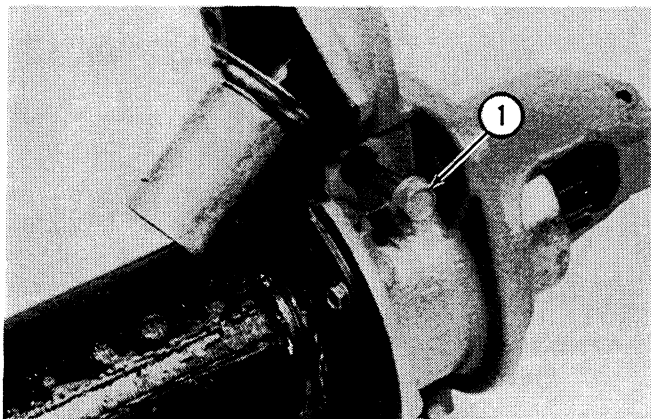

1. Pivot Bolt and Seal  
Figure 13

14. Pull the drive housing from the armature shaft.

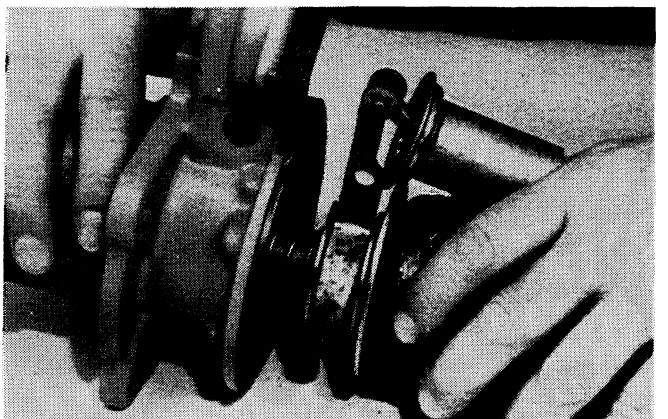
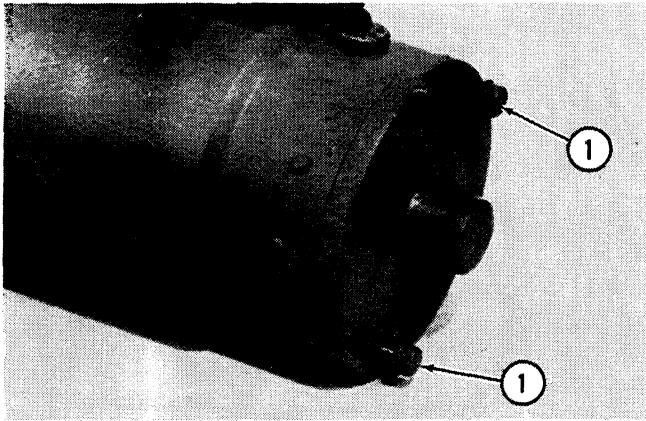

Figure 16

18. Install the two cap screws which fasten the end cap and the field frame to the drive housing.



1. Cap Screw

Figure 72

19. Install the gasket on the drive housing.

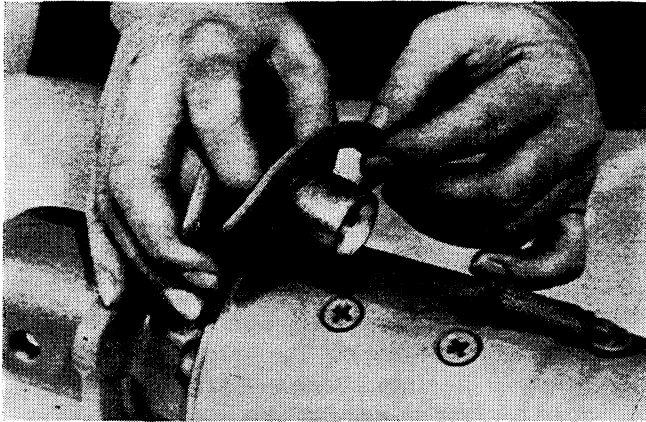

Figure 73

20. Install the spring on the plunger.

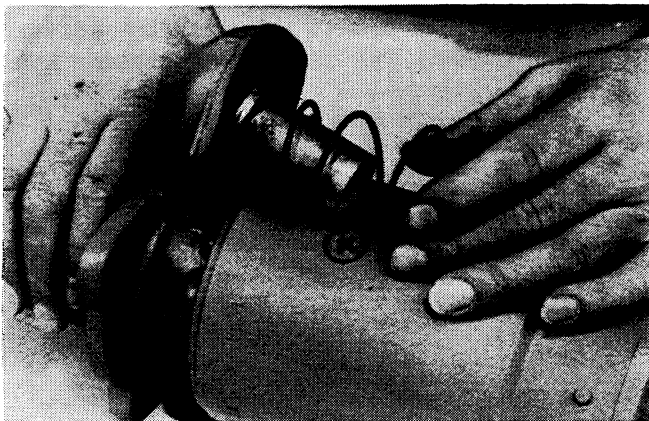

Figure 74

21. Push the starter solenoid onto the spring and plunger. Then turn the starter solenoid to engage the flange on the starter solenoid with the groove between the field frame and the drive housing.

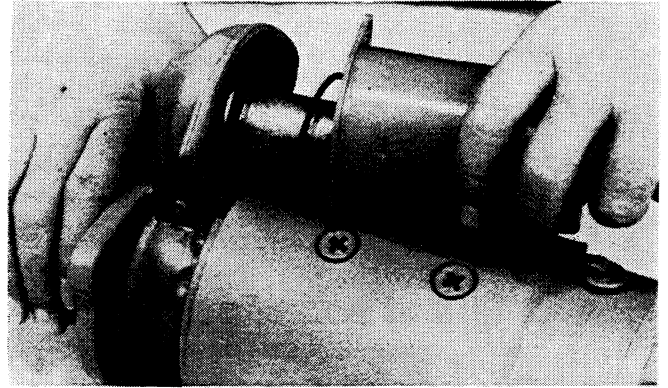
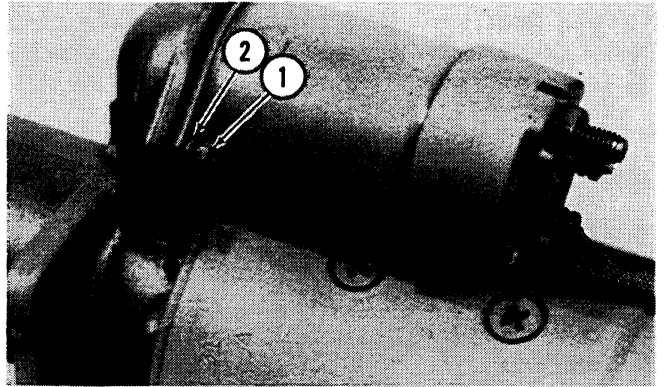

Figure 75

22. Install the two cap screws and lock washers which fasten the starter solenoid to the drive housing.



1. Cap Screw  
2. Lock Washer

Figure 76

23. Install the cap screw which fastens the field coil connector to the motor terminal on the starter solenoid.

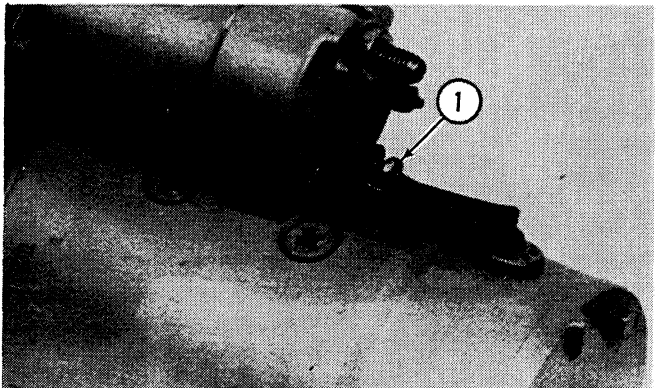

1. Cap Screw

Figure 77

## SPECIFICATIONS

### Original equipment alternator

Case part number ..... L102693

Delco-Remy part number ..... 1103125

### Service replacement alternator

Case part number ..... A47623

Delco-Remy part number ..... 1103133

Rated output of alternator ..... 42 amperes at 13 volts

Voltage regulator ..... Internal part of alternator, solid state construction, not adjustable

### Torque specifications

Pulley nut ..... 40 - 45 pound-feet (54 - 61 N m)

BAT terminal nut ..... 25 - 40 pound-inches (3 - 4 N m)

## GENERAL INFORMATION

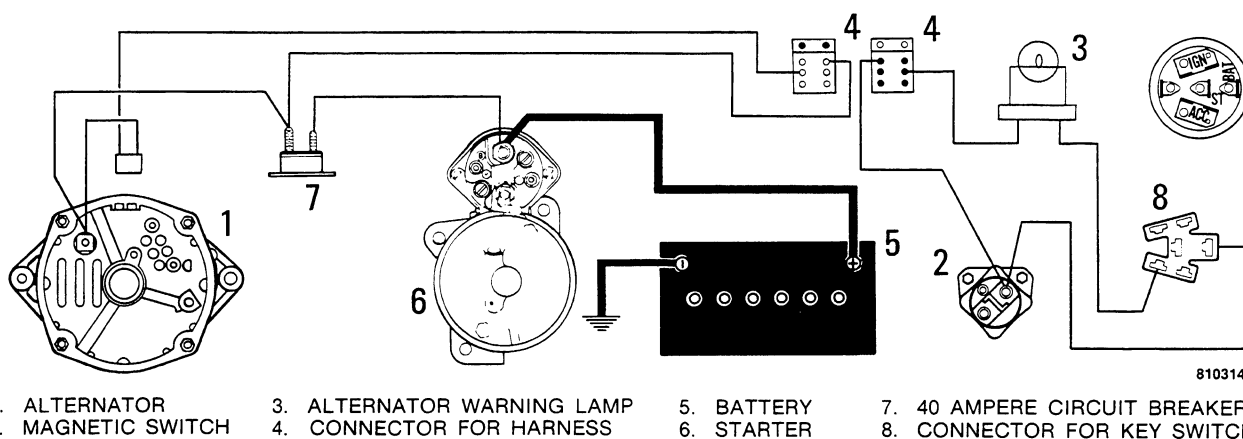

1. ALTERNATOR  
2. MAGNETIC SWITCH

3. ALTERNATOR WARNING LAMP  
4. CONNECTOR FOR HARNESS

5. BATTERY  
6. STARTER

7. 40 AMPERE CIRCUIT BREAKER  
8. CONNECTOR FOR KEY SWITCH

Figure 1 - Charging Circuit

The charging circuit includes the battery, alternator with an internal voltage regulator, key switch, 30 ampere fuse, ammeter, and the wiring to connect these parts. The charging circuit is shown in Figure 1.

The components of the alternator are the front housing, rotor, stator, rectifier bridge, diode trio, voltage regulator, condenser, brush holder, and rear housing.

When the rotor is turned inside the stator, an alternating current is generated in the stator coils. This alternating current is changed to direct current by the positive rectifier diodes and the negative rectifier diodes in the rectifier bridge. The positive rectifier diodes and the negative rectifier diodes are connected to the stator coils. The direct current leaves the alternator at the BAT terminal.

All rectifier diodes have a high resistance to current flow in one direction and a low resistance to current flow in the opposite direction. Each negative rectifier diode and positive rectifier diode is connected to the stator to let the current flow in the low resistance direction. The high resistance of the opposite direction prevents current flow from the battery to the alternator.

The rotor (field) is an electric magnet. A starting current must be sent to the field before the alternator will start charging. The current to cause the alternator to start charging comes from the battery through the 30 ampere fuse, the key switch, and the voltage regulator. When the voltage from the alternator is higher than the battery voltage, the current for the field comes from the BAT terminal of the alternator through the voltage regulator.

The output of the alternator is controlled by the amount of current that is sent to the field. A part of the voltage regulator works like a switch to adjust the current flow to the field. The voltage regulator constantly compares output voltage and battery voltage and adjusts the current flow to the field according to this comparison.

The condenser connected to the rectifier bridge prevents damage to the charging circuit from surges of high voltage that can cause damage to the diode trio, the negative rectifier diodes, or the positive rectifier diodes. If a new diode trio or rectifier is installed, it is recommended that a new condenser be installed also.

6. Install and tighten the cap screw that fastens the condenser to the rear housing. Install and tighten the cap screw that fastens the condenser lead to the rectifier bridge.

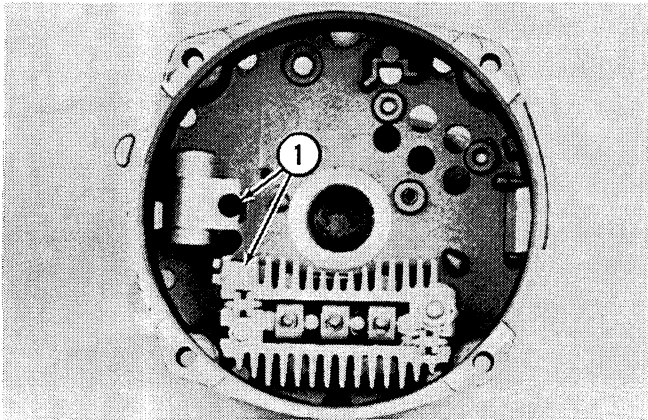

1. Cap Screw

Figure 47

9. If a new brush holder is being installed, put the connector in the slot in the brush holder. Then use a screwdriver to bend the tab on the connector away from the connector to hold the connector in position.

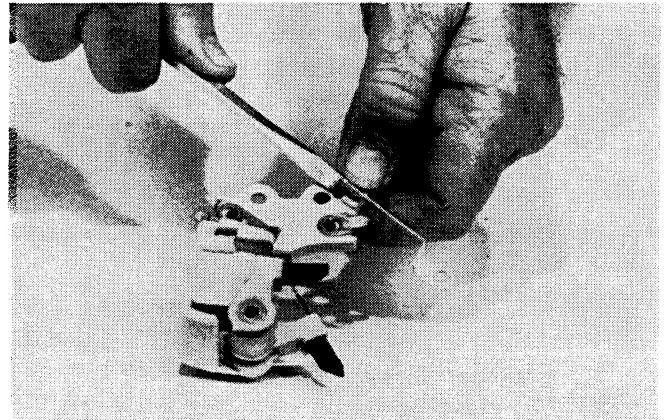
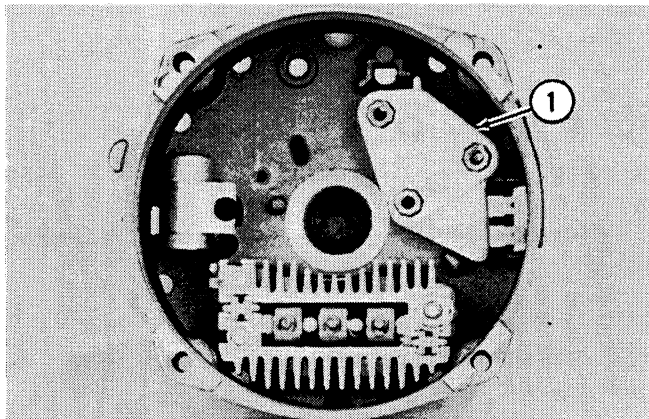

Figure 50

7. Put the voltage regulator in the rear housing.



1. Voltage Regulator

Figure 48

10. Put the brush holder in the rear housing and on the voltage regulator as shown in Figure 51.

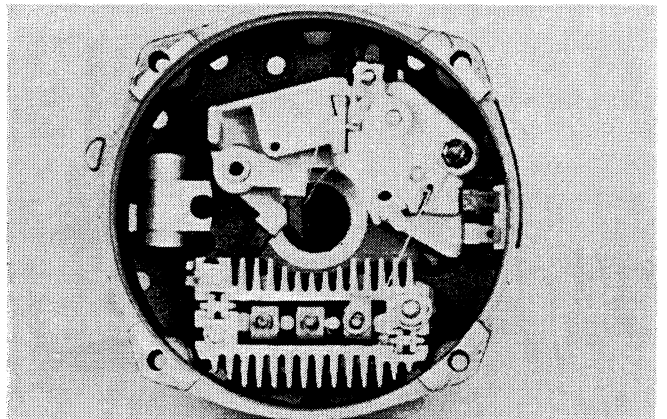

1. Brush Holder

Figure 51

8. Install but do not tighten the cap screw that fastens the voltage regulator to the rear housing.

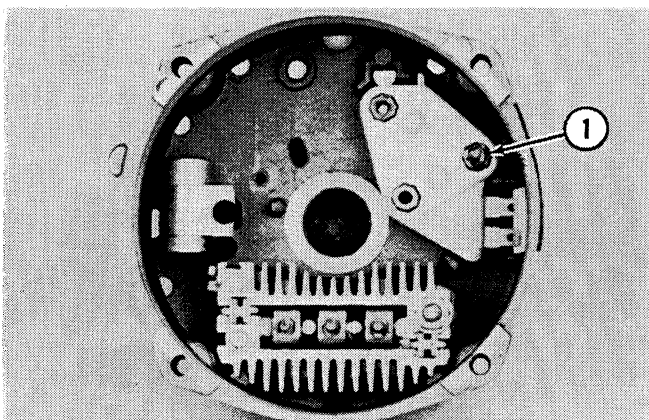

1. Cap Screw

Figure 49

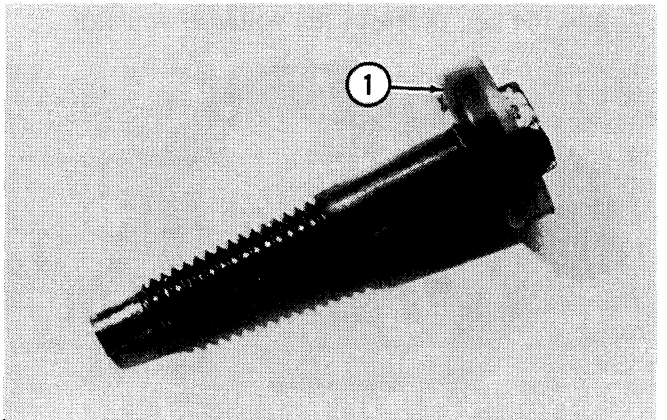

1. Insulator

Figure 52

11. Check the condition of the insulator on each insulator screw. If an insulator is damaged in any way, use a new insulator screw.

## CHECKING THE OPERATION OF A GAUGE

### Water Temperature, Oil Temperature, and Fuel Level

1. If a gauge does not work correctly, do the following steps:
  - a. Find the sender for the gauge that does not work correctly.
  - b. Disconnect the wire from the sender.
  - c. Turn the key switch to the On position.
  - d. Hold the end of the wire against the frame of the machine or against the engine to make a ground connection. Make sure that the end of the wire makes a good ground connection.
  - e. Look at the gauge. The needle in the gauge must move all the way to the top of the gauge while the wire for the gauge is making a ground connection.
  - f. If the needle did not move, the problem is in the wire for the gauge or in the gauge. If the needle did move, install a new sender.
  - g. Turn the key switch to the Off position.
  - h. Check the wire for the gauge with an ohmmeter. Connect one of the ohmmeter leads to the end of the wire that was connected to the sender. Connect the other ohmmeter lead to the terminal in the connector for the instrument cluster. See Figure 5, Section 4003 to locate the correct terminal in the connector.
  - i. If the wire is good, install a new gauge.
2. If the gauge works part of the time, do the following steps:
  - a. Check for loose connections at the sender and gauge. Also check for corrosion at the connections.

- b. Check to see if the wire for the gauge is making a ground connection to the frame or to the engine part of the time.
- c. If you cannot find the cause of the problem, install a new sender. If the new sender does not correct the problem, install a new gauge.

### Volts

1. If the volt gauge does not work correctly, do the following steps:
  - a. Connect the leads of a voltmeter to the posts of the battery.
  - b. Start and run the engine at 1500 rpm (r/min).
  - c. Look at the voltmeter. Read the indication of the voltmeter.
  - d. Look at the volts gauge. See Figure 5. Compare the indication of the volts gauge with the indication of the voltmeter.
  - e. If the indications of the volts gauge and the voltmeter are not approximately the same, install a new volts gauge.

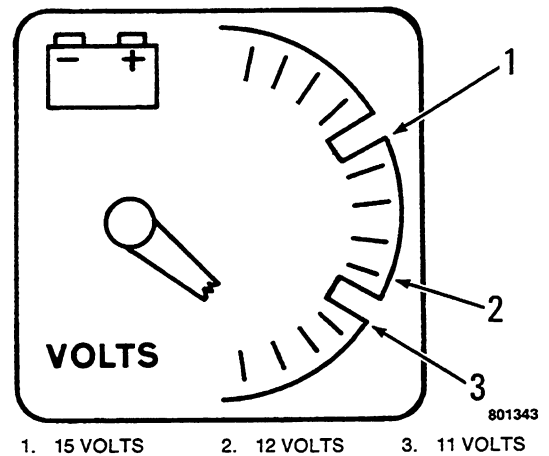

Figure 5

## REMOVAL

1. Remove the dirt from the hose connections at the steering pump.
2. Disconnect the hose from the top fitting in the steering pump.
3. Fasten an identification tag on the hose just disconnected so that the hoses will be connected correctly during installation.
4. Disconnect the hose from the bottom fitting.
5. The cap screws that hold the steering pump in place are installed from the front through the timing gear cover.
6. Loosen the cap screws that hold the steering pump in place and remove the steering pump from the engine.
7. If the gasket stayed on the engine, remove the gasket from the engine.

## INSTALLATION

1. Put a new gasket on the body of the steering pump.
2. Hold the steering pump in place and start the cap screws into the body.
3. Tighten the cap screws to 25 - 35 pound-feet (34 - 47 N m).
4. Connect the hose without the identification tag to the bottom fitting in the steering pump.
5. Connect the other hose to the top fitting in the steering pump.
6. Fill the reservoir on the steering pump with 1 U.S. quart (0.9 litre) of Case TCH Fluid.
7. Start the engine and run the engine at low idle.
8. Turn the steering wheel all the way to the right and left several times to remove air in the steering system.
9. Stop the engine. Check for oil leaks. Also check the level of the oil in the reservoir and add oil as needed.

31. Install the spring.

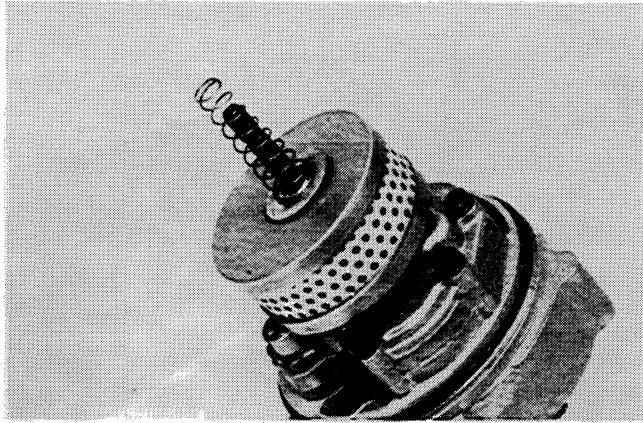

Figure 63

32. Install the nut and tighten the nut with your fingers.

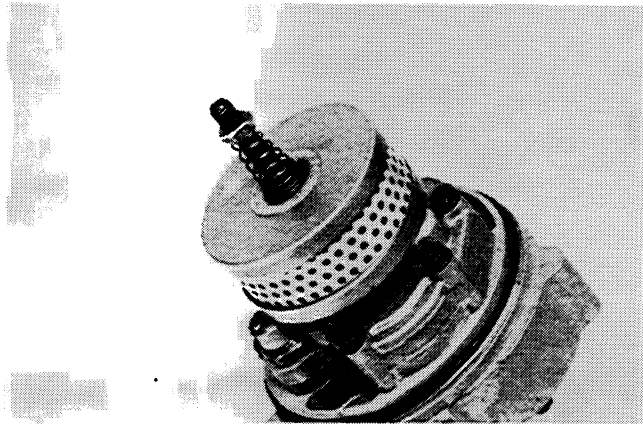
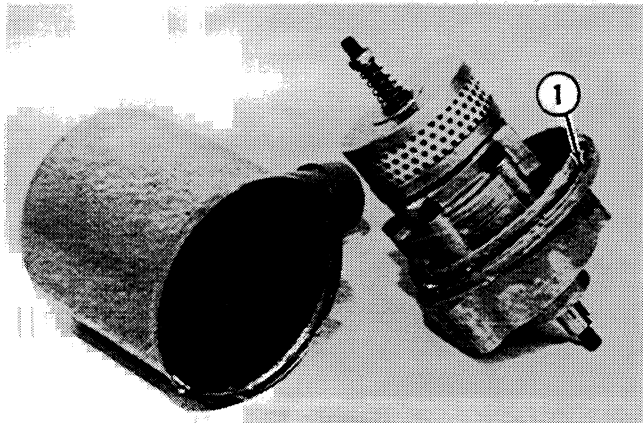

Figure 64

33. Lubricate the O-ring and the bore of the reservoir with petroleum jelly.



1. O-ring

Figure 65

34. Install the reservoir. Be sure the alignment marks on the reservoir and body are aligned.

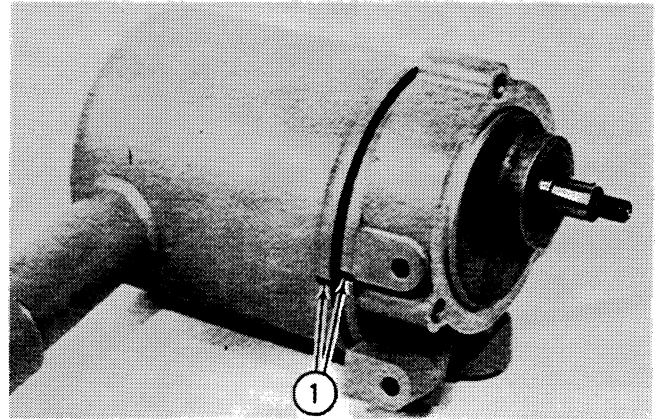

1. Alignment Mark

Figure 66

35. Install the sealing washer.

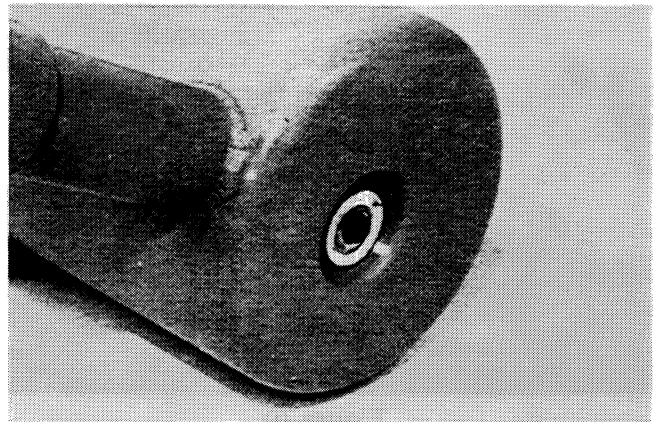

Figure 67

36. Install the dome nut. Tighten the dome nut to 25 pound-feet (34 N m).

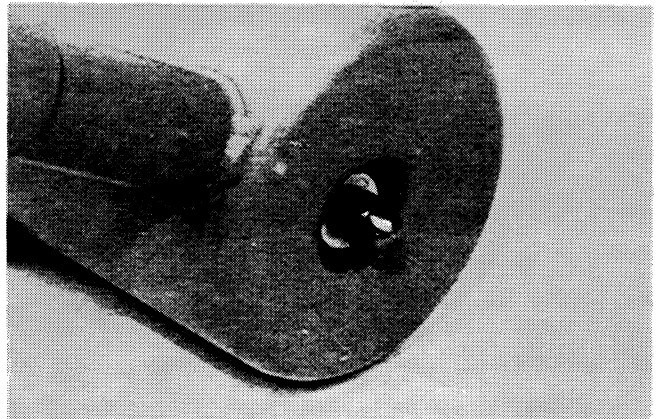

Figure 68

## STEERING CONTROL VALVE

### Removal

1. Park the machine on a level surface and engage the parking brake.
2. If equipped, put the loader bucket flat on the floor and the backhoe in the transport position.
3. Loosen and remove the cap screws that fasten the front floor plate to the frame.
4. Raise the front floor plate and disconnect the wiring from the clutch cutout switch. Put the front floor plate out of the way.
5. Remove the dirt from the steering control valve and the area around the steering control valve.
6. Remove the cap from the center of the steering wheel. The cap is held by the fit of an O-ring.
7. Loosen and remove the nut that holds the steering wheel in place.
8. Use an acceptable puller and remove the steering wheel.
9. Loosen the two cap screws that hold the clamp for the steering column in place.
10. Loosen the nut on the bolt in the clamp at the bottom of the steering column.
11. Pull the tube up until you can see the coupling at the bottom of the shaft.
12. Remove the retaining ring at the bottom of the coupling.
13. Use a hammer and punch to remove the pin from the coupling.
14. Disconnect the tubes from the steering control valve.
15. Loosen the Ferry head screws that hold the steering control valve in place.
16. Hold the steering control valve and remove the Ferry head screws.
17. Remove the steering control valve.
18. Put a plug in each tube that was disconnected.
2. Hold the steering control valve in place and install the Ferry head screws. If a new Ferry head screw is needed, the replacement must be the same as specified in the parts catalog to prevent damage to the steering control valve.
3. Tighten the Ferry head screws that hold the steering control valve in place.
4. Connect the tubes to the steering control valve.
5. Lower the shaft in the steering column onto the input shaft in the steering control valve.
6. Align the hole in the coupling with the hole in the input shaft.
7. Install the pin that fastens the coupling to the input shaft.
8. Put the retaining ring in the groove in the coupling.
9. Lower the steering column onto the steering control valve.
10. Hold the clamp in place at the bottom of the tube and tighten the nut on the bolt in the clamp to 15-20 pound-feet (20 - 27 N m).
11. Tighten the cap screws for the clamp that holds the steering column in place.
12. Install the steering wheel.
13. Install the nut that holds the steering wheel in place. Do not tighten the nut now.
14. Start the engine and run the engine at low idle.
15. Turn the steering wheel all the way to the right and left several times to remove any air in the steering system.
16. Check the oil level in the reservoir on the steering pump and add oil as required.

**NOTE:** If you are installing a steering control valve that has been rebuilt, go to step 17. Go to step 18 if the steering control valve has not been rebuilt or is new.

### Installation

1. Remove the plugs from the tubes.
  - a. Run the engine at low idle.
  - b. Use a pound-inch torque wrench and turn the steering wheel to the right.

25. Remove the drive link. Then install the drive link so that the slot in the drive link will engage the pin in the torsion bar.

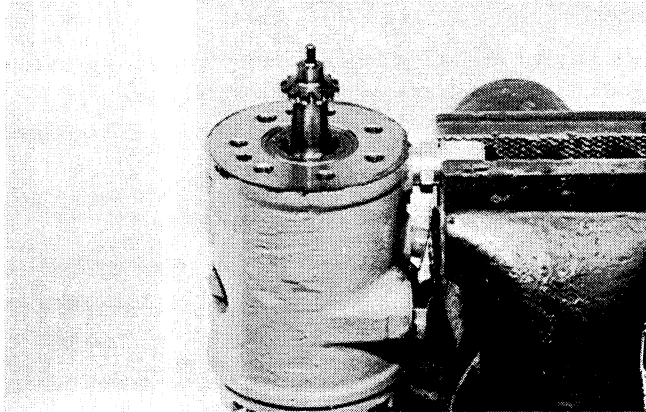

Figure 52

26. Use a straightedge and feeler gauge as shown in Figure 53 to measure the distance from the end of the body to the end of the spool. The distance must be .0025 inch (0.063 mm) or less.

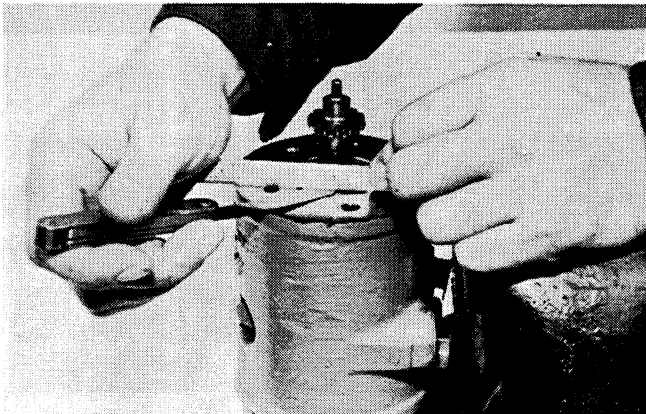
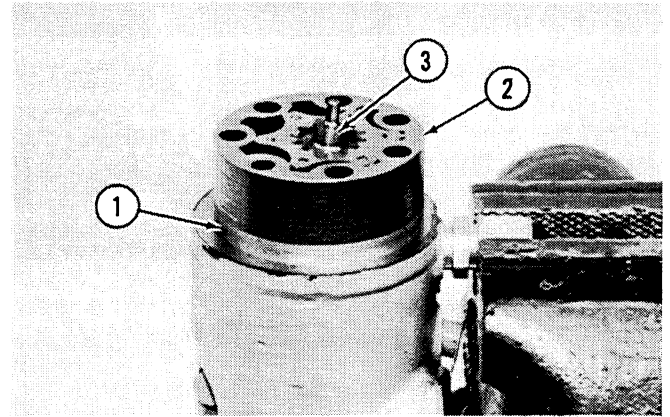

Figure 53

27. If the distance between the end of the body and the end of the spool is not .0025 inch (0.063 mm) or less, remove the cover from the input shaft. Remove or add shims under the cover as necessary to put the spool in the correct position in relation to the body.
28. Repeat steps 18 through 27 until the spool is in the correct position.

29. Put the spacer on the bench with the flat side up. Carefully put the rotor and stator as an assembly on the spacer. Install the spacer, rotor, and stator as an assembly to prevent the rotor from falling out of the stator. Turn the spacer, rotor, and stator as necessary to align the splines in the rotor with the splines on the drive link.



1. Spacer
2. Rotor and Stator
3. Drive Link

Figure 54

30. Put the manifold in position on the rotor and stator as shown in Figure 55. Turn the spacer, stator, and manifold as necessary to put the holes for the cap screws in alignment with the holes in the body.

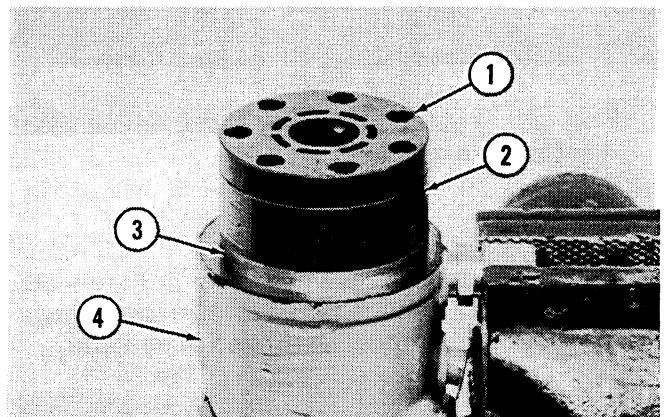

1. Manifold
2. Stator
3. Spacer
4. Body

Figure 55

# Section 5021

## FRONT AXLE

Written In *Clear  
And  
Simple  
English*

5. Remove the cotter pin that holds the nut in place.

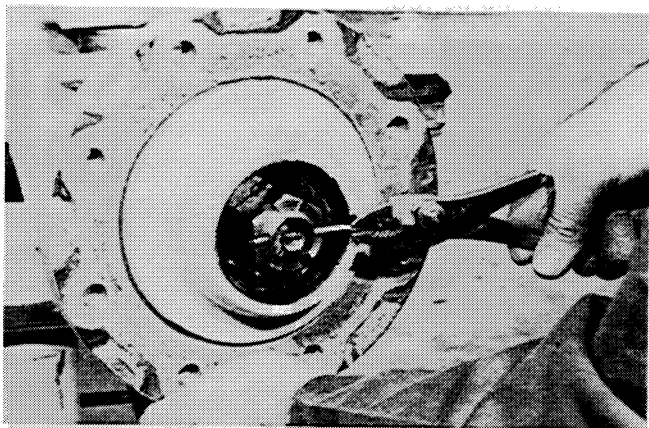

Figure 49

8. Remove the flat washer and wheel bearing.

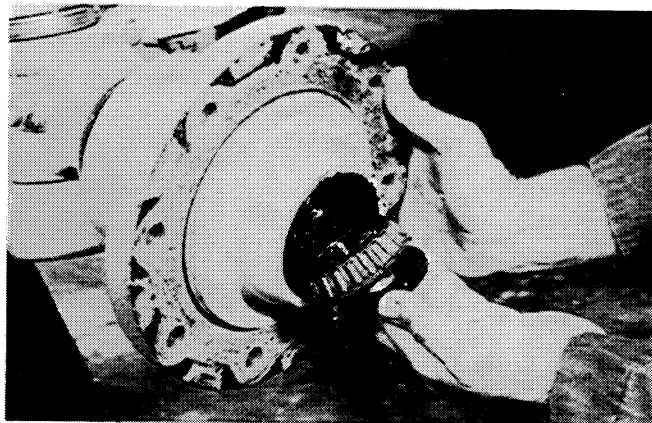

Figure 52

6. Remove the nut.

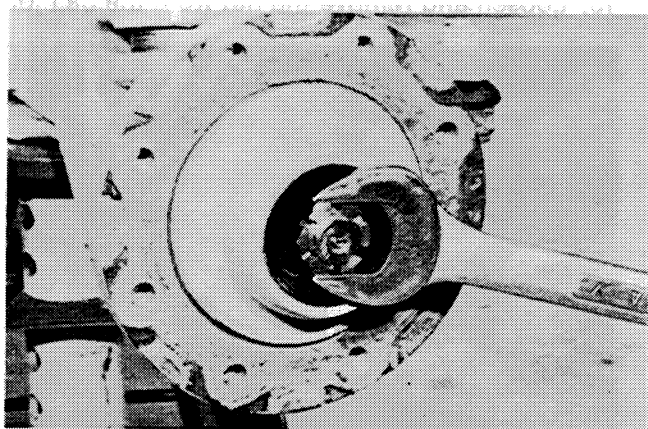

Figure 50

9. Remove the hub.

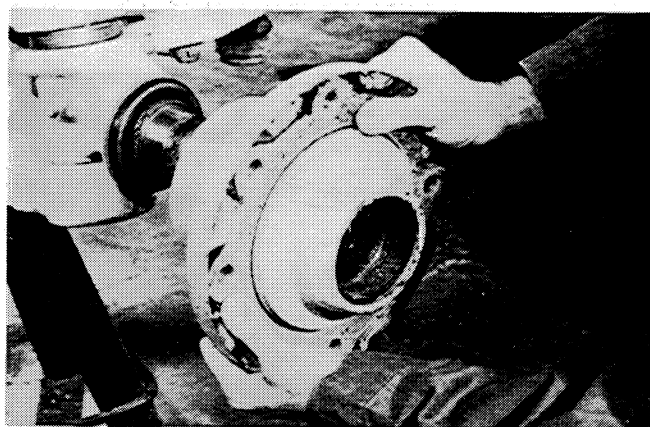

Figure 53

7. Hit the hub with a soft hammer to remove the outer wheel bearing from the spindle.

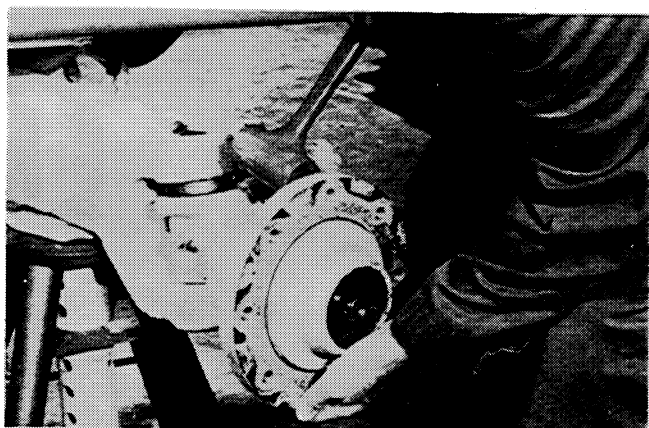
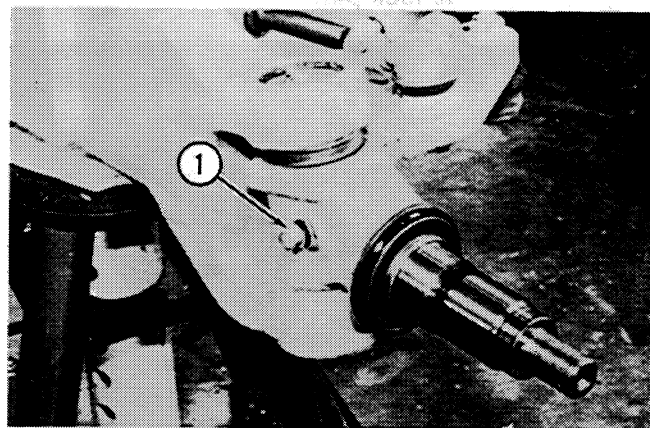

Figure 51

10. Loosen the nut on the lock pin until the nut is even with the end of the lock pin.



1. Nut

Figure 54

7. Remove the snap ring at the bottom of the king-pin.

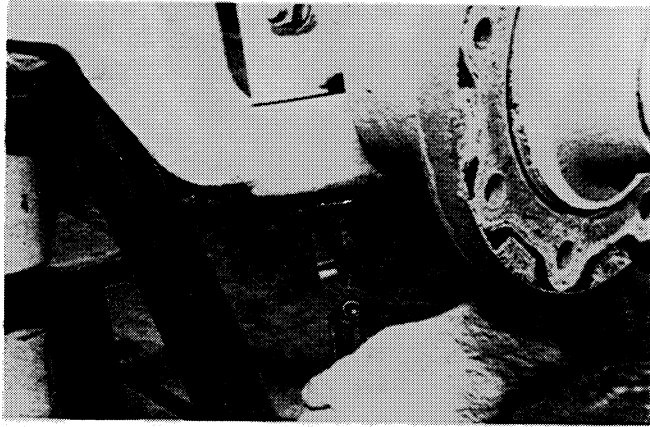

Figure 121

10. Loosen the nut on the lock pin until the nut is even with the end of the lock pin.

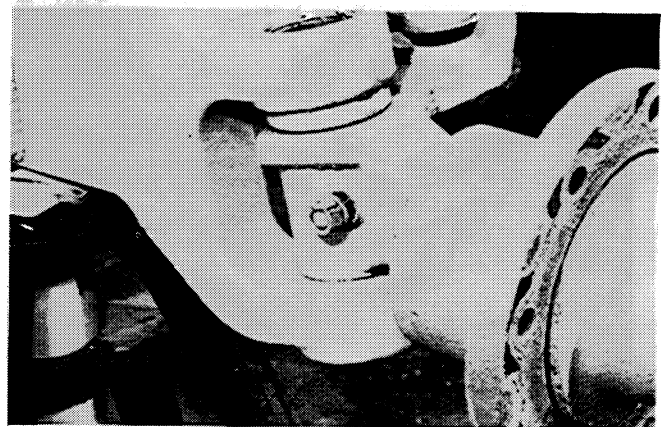

Figure 124

8. Remove the spacer.

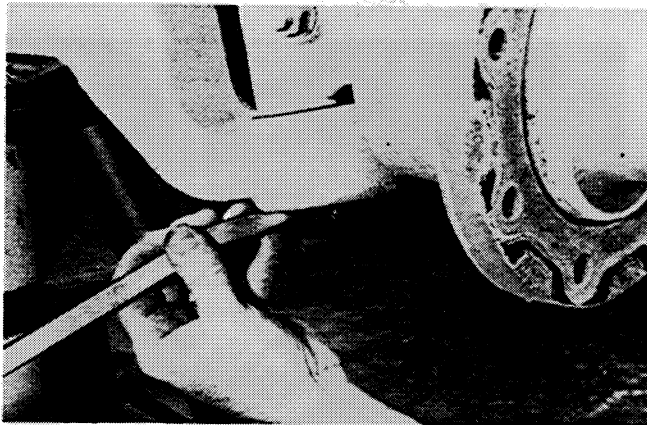

Figure 122

11. Hit the lock pin with a hammer to loosen the lock pin.

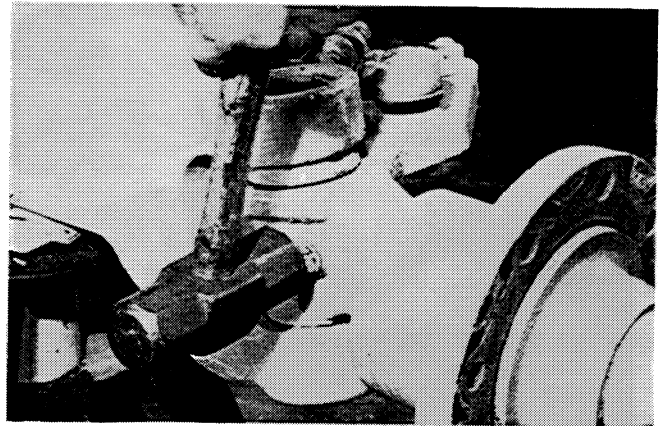

Figure 125

9. Remove the O-ring.

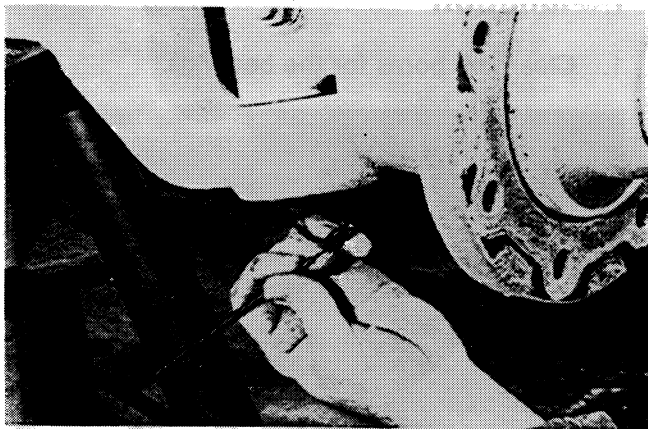

Figure 123

12. Remove the nut and lock washer from the lock pin.

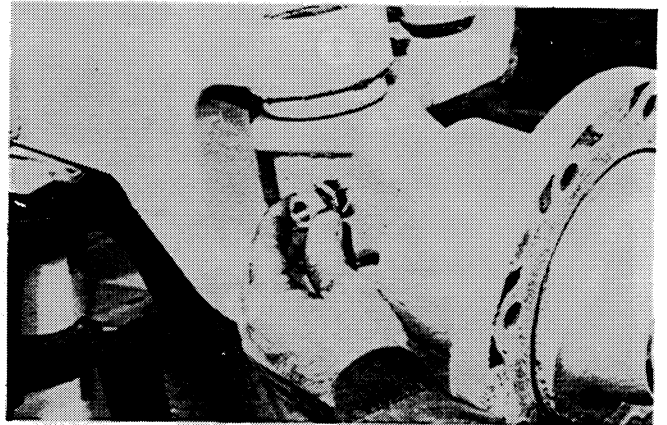

Figure 126

## SPECIFICATIONS

Oil temperature for the tests .....	Needle in the gauge for Oil Temp must be in the center of the green area on the gauge
Charging pump pressure	
Engine at low idle .....	65 psi (448 kPa) minimum in neutral
Engine at 2000 rpm (r/min) .....	130 psi (896 kPa) minimum in neutral
Cooling system pressure	
Engine at 2000 rpm (r/min) .....	25 psi (172 kPa) or less
Type of oil .....	Case TCH Fluid
Alternate oil .....	Type C-3 transmission and hydraulic fluid. Type C-2 transmission and hydraulic fluid, such as Tenneco Hytrans fluid. Automatic transmission fluid Type A, such as Dexron.
Oil capacity (approximate)	
Power shuttle .....	2-1/4 U.S. quarts (2.1 litres)
Torque converter .....	5-1/2 U.S. quarts (5.2 litres)
Total system .....	9 U.S. quarts (8.5 litres)

## MAINTENANCE AND SERVICE

### Oil Level Check

Check the level of the oil in the power shuttle every 10 hours of operation or each day, whichever occurs first.

1. Park the machine on a level surface.
2. Apply the parking brake.
3. Put the transmission control lever in fourth gear.
4. Put the power shuttle control lever in the Forward position.
5. Run the engine at full throttle. If the machine moves, see Section 7106 and adjust the parking brake.
6. Run the engine at full throttle for 40 seconds. Then put the power shuttle control lever in neutral.
7. Continue to run the engine at full throttle for 10 seconds.
8. Decrease the engine speed to low idle.
9. Repeat steps 4 through 8 until the needle in the gauge for Oil Temp is in the center of the green area on the gauge.
10. Run the engine at low idle with the power shuttle control lever in neutral for approximately 10 seconds.
11. Continue to run the engine at low idle. See Figure 1. Check the level of the oil in the power shuttle.

12. The level of the oil in the power shuttle must be between the add and the full marks on the dipstick.
13. Add oil as necessary.

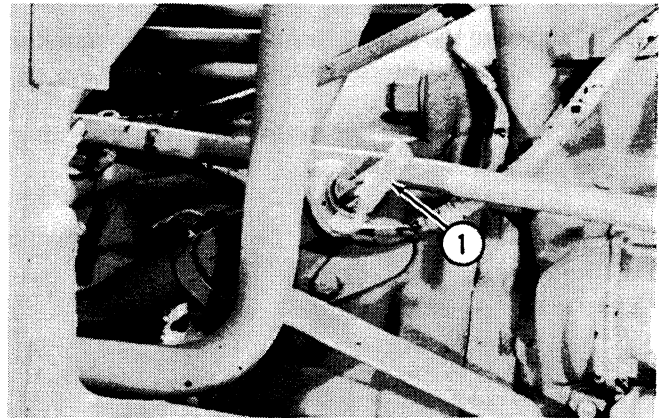

1. Dipstick

Figure 1

### Oil Change

Change the oil in the power shuttle and clean the suction screen every 1000 hours of operation or every year, whichever occurs first.

1. Do steps 1 through 9 under Oil Level Check.
2. Stop the engine.
3. The oil must be drained from the torque converter and from the oil pan on the power shuttle. There is a rubber plug on the bottom of the torque converter housing.

11. Decrease the engine speed to low idle.
12. Put the power shuttle control lever in the Forward position. Increase the engine speed to full throttle.
13. Write the pressure gauge indication on line 8 of the check sheet.
14. Decrease the engine speed to low idle.
15. Put the power shuttle control lever in the Reverse position. Increase the engine speed to full throttle.
16. Write the pressure gauge indication on line 9 of the check sheet.
17. Decrease the engine speed to low idle. Put the power shuttle control lever in neutral. Stop the engine.

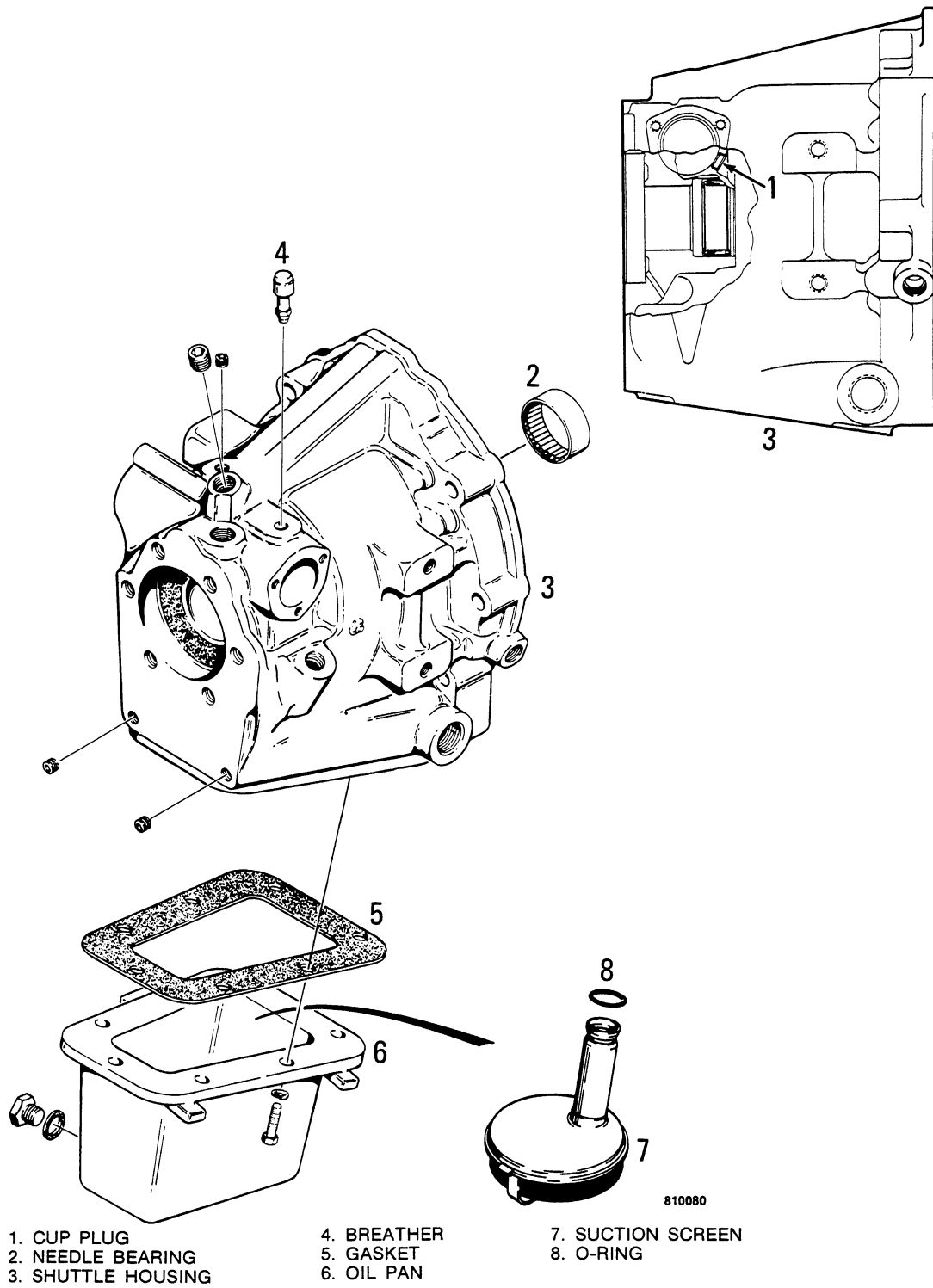

Figure 5 - Shuttle Housing and Oil Pan

- e. Install the four cap screws through the reinforcement ring and flex plate into the torque converter. Tighten the cap screws to 38 - 42 pound-feet (52 - 57 N m).

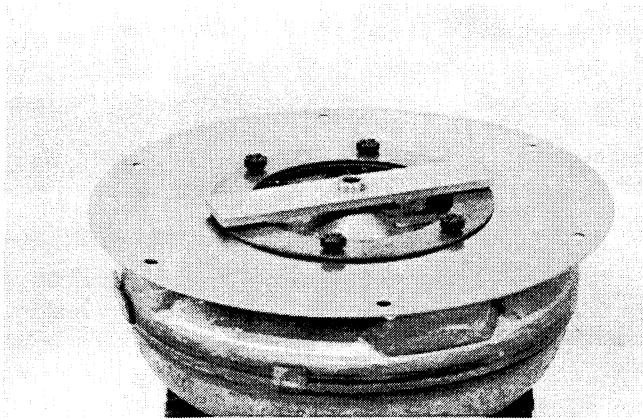

Figure 38

- f. Remove the tool. Install the other two cap screws. Tighten the cap screws to 38 - 42 pound-feet (52 - 57 N m).

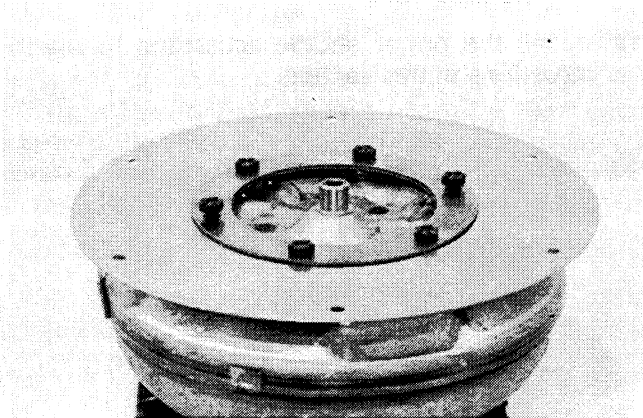

Figure 39

3. Put the torque converter and the flex plate in position against the flywheel.

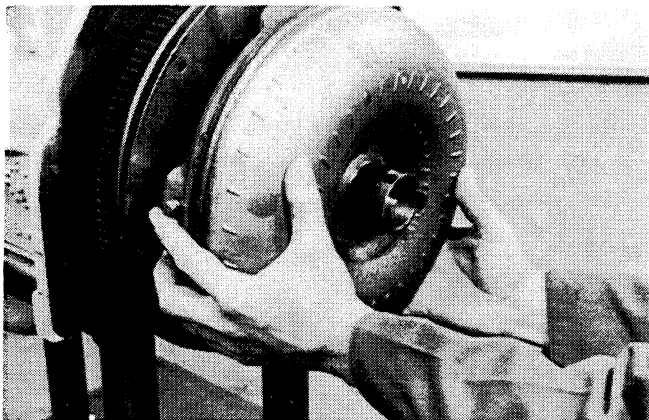
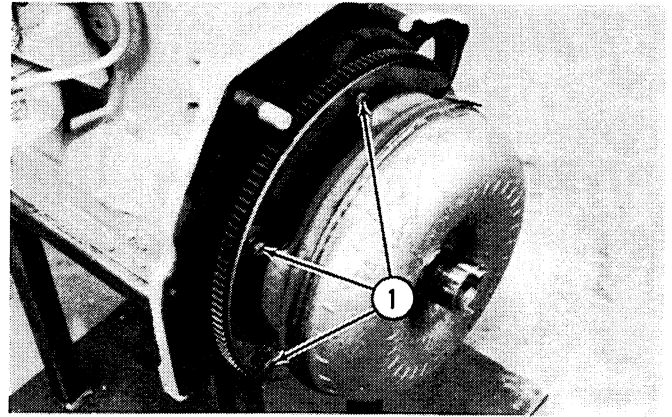

Figure 40

4. Install the cap screws and flat washers to fasten the flex plate to the flywheel.



1. Cap Screws

Figure 41

5. Use a dial indicator to check the position of the torque converter. Use a wrench on one of the cap screws for the hydraulic pump coupling to turn the crankshaft of the engine. Look at the dial indicator as the torque converter turns. The torque converter must be centered on the flywheel to within .004 inch (0.1 mm) so that the full indicated movement on the dial indicator is .008 inch (0.2 mm) or less.

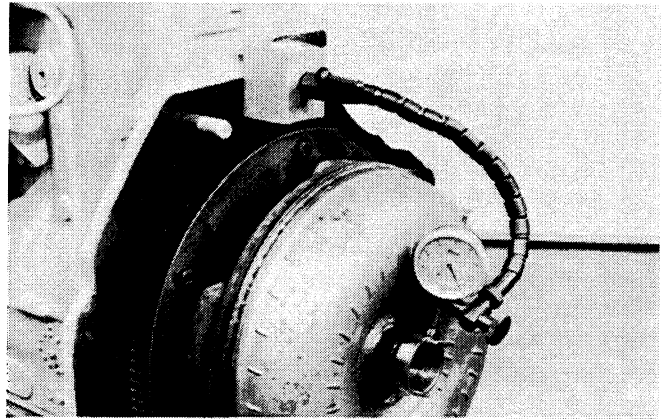

Figure 42

6. After the torque converter is centered on the flywheel, tighten the cap screws to 13 - 15 pound-feet (18 - 20 N m).
7. If the engine is in the tractor and you are installing a new torque converter housing, install the two rubber mounts in the torque converter housing. See Figure 43.

5. If the bushing in the cover is worn or damaged, put the cover in the press.

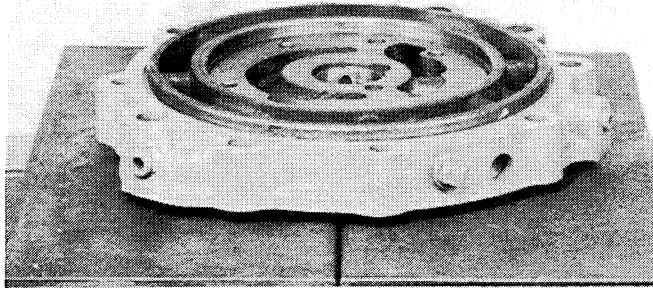

Figure 103

6. Press the bushing from the cover.

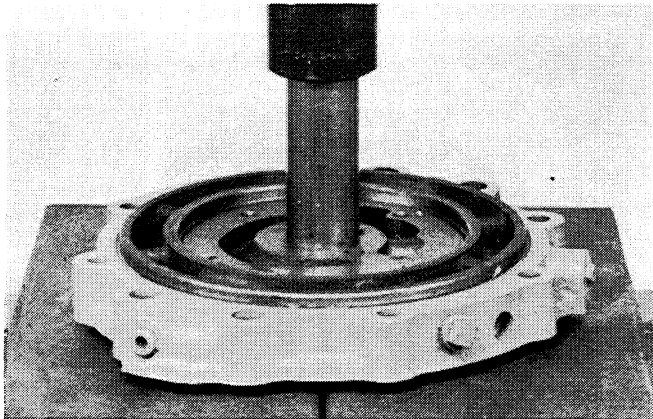
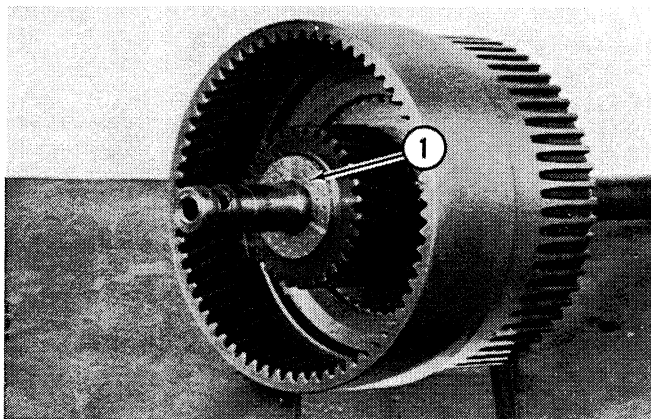

Figure 104

### Forward Clutch

1. Remove the thrust washer from the forward clutch.



1. Thrust Washer  
Figure 105

2. Put the forward clutch in the press.

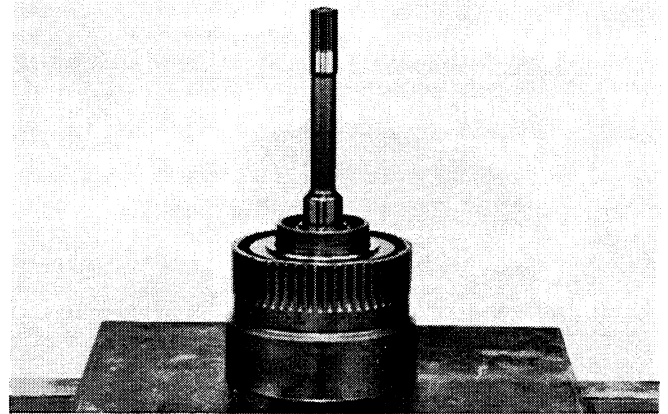
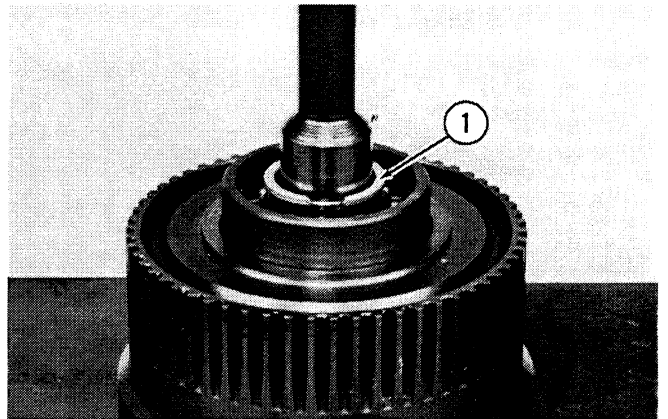

Figure 106

3. Remove the snap ring from the groove in the input shaft.



1. Snap Ring  
Figure 107

4. Press the input shaft from the forward clutch. Do not let the input shaft fall.

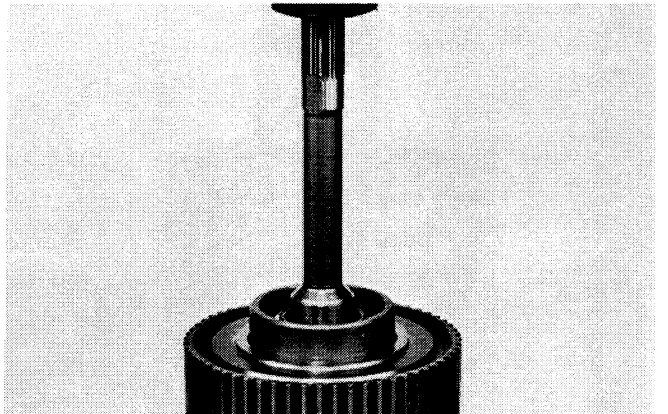

Figure 108

3. Install a new O-ring in the cylinder.

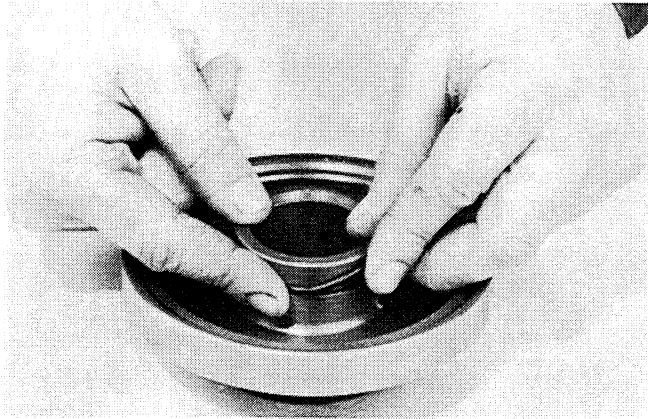

Figure 169

4. Put clean oil on the quad ring and the O-ring. Push the piston into the cylinder.

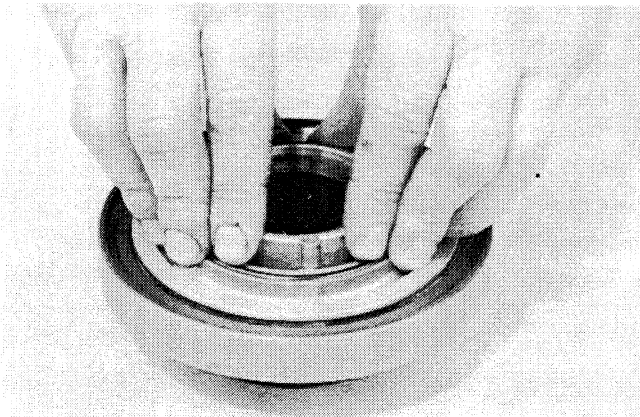
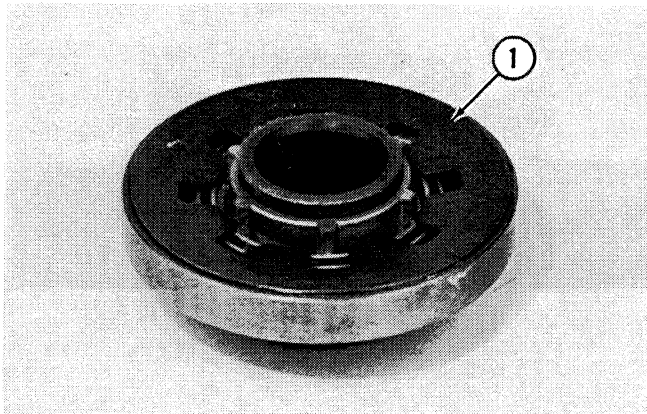

Figure 170

5. Put petroleum jelly on the clutch spring. Install the clutch spring in the cylinder on top of the piston as shown in Figure 171. The petroleum jelly will keep the clutch spring in position when the cylinder and piston assembly is installed in the ring gear.



1. Clutch Spring  
Figure 171

6. Install the Woodruff key in the input shaft.

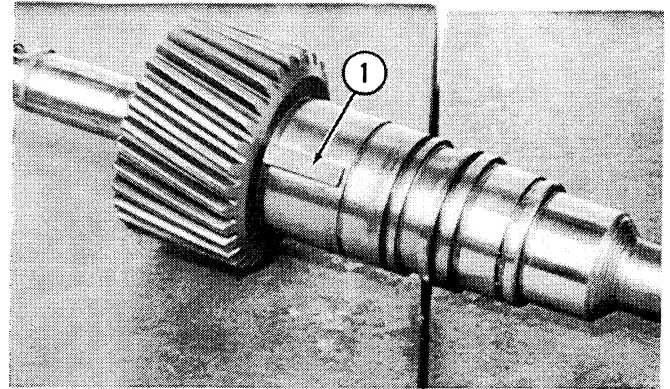

1. Woodruff Key  
Figure 172

7. Put the clutch hub in the press as shown in Figure 173.

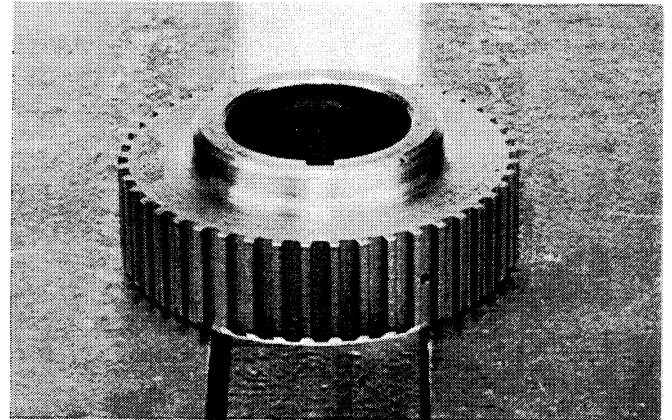

Figure 173

8. Put the input shaft in the clutch hub so that the Woodruff key is in alignment with the keyway in the clutch hub.

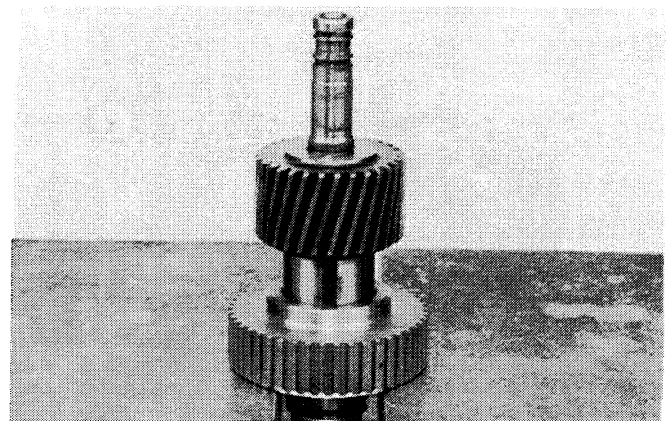

Figure 174

CLICK HERE TO **DOWNLOAD** THE COMPLETE MANUAL

- Thank you very much for reading the preview of the manual.
- You can download the complete manual from: [www.heydownloads.com](http://www.heydownloads.com) by clicking the link below



- Please note: If there is no response to CLICKING the link, please download this PDF first and then click on it.

CLICK HERE TO **DOWNLOAD** THE COMPLETE MANUAL

26. Put form-in-place gasket material on the housing.

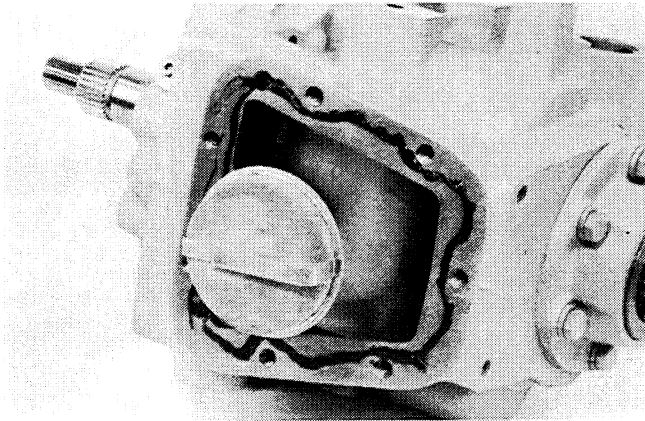

Figure 231

29. Put petroleum jelly on the detent cam. Put the detent cam in position on the end of the control valve.

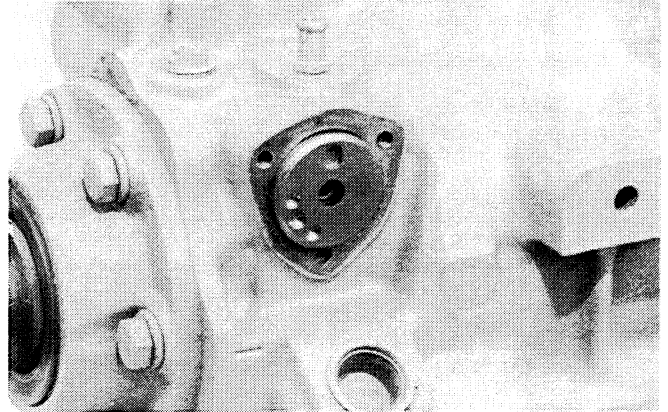

Figure 234

27. Install the oil pan. Tighten the cap screws.

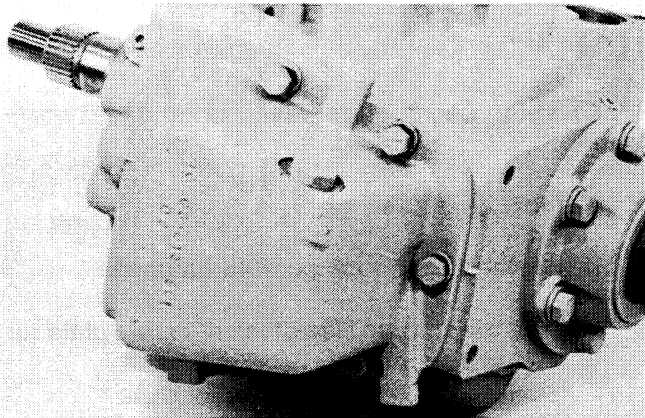

Figure 232

30. Put petroleum jelly on the detent ball. Put the detent ball in one of the recessed areas in the detent cam. Put the detent spring in the valve cover and install the valve cover with a new gasket. Make sure that the detent spring is in position on the detent ball.

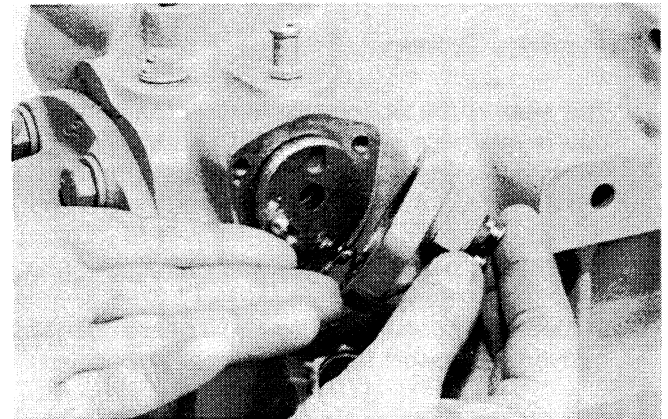

Figure 235

28. Put clean oil on the control valve. Install the control valve in the housing.

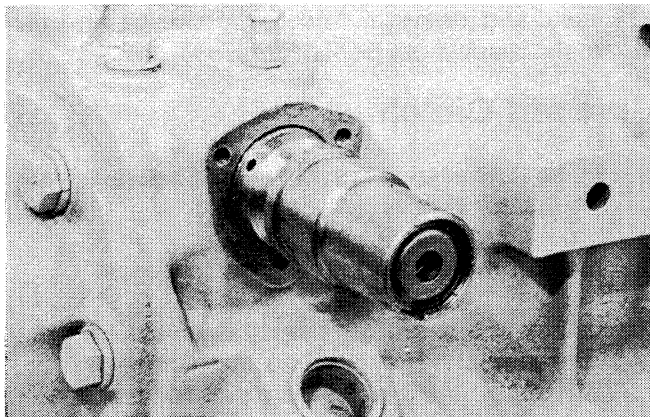

Figure 233

31. Install the cap screws and lock washers to fasten the valve cover to the housing.

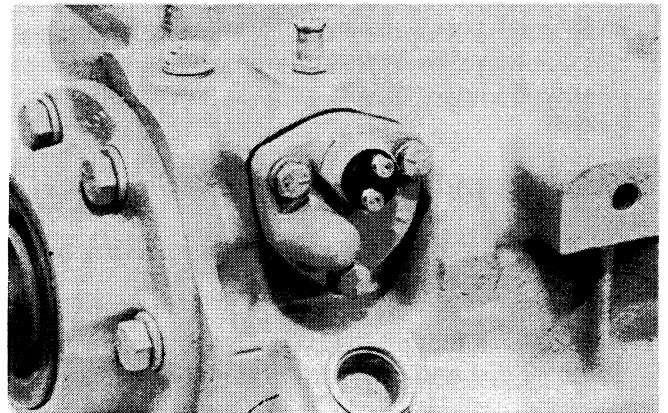

Figure 236

## OIL LEVEL CHECK

Check the level of the oil in the transaxle after every 100 hours of operation.

1. Park the machine on a level surface.
2. Stop the engine.
3. The dipstick for the transaxle is located below the floor plate.
4. Remove the plug from the floor plate.

5. Check the level of the oil on the dipstick.

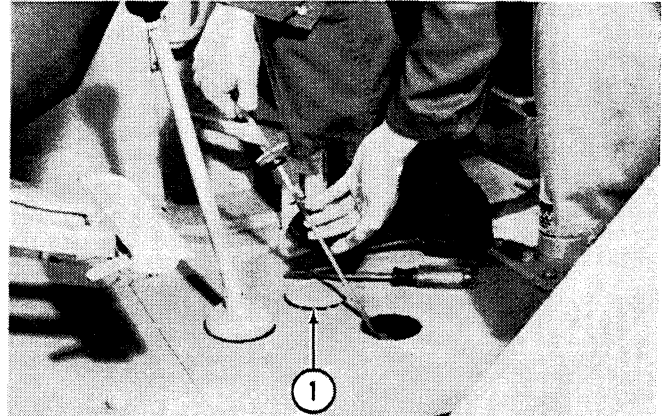

1. Plug

Figure 1

6. The level of the oil must be between the Add and the Full marks on the dipstick.
7. If the level of the oil is not correct, see Section 1002 and add the correct oil.

## OIL CHANGE

Change the oil in the transaxle after every 1000 hours of operation.

1. Park the machine on a level surface.
2. Stop the engine and apply the parking brake.
3. The transaxle holds approximately 20 U.S. quarts (18.9 litres) of oil.
4. Put a container below the drain plug in the bottom of the transaxle.

5. Remove the drain plug and drain the oil into the container.
6. After all the oil has drained from the transaxle, install the drain plug.
7. See Section 1002. Fill the transaxle with approximately 20 U.S. quarts (18.9 litres) of the correct oil.
8. Check the level of the oil in the transaxle. Add oil as necessary.

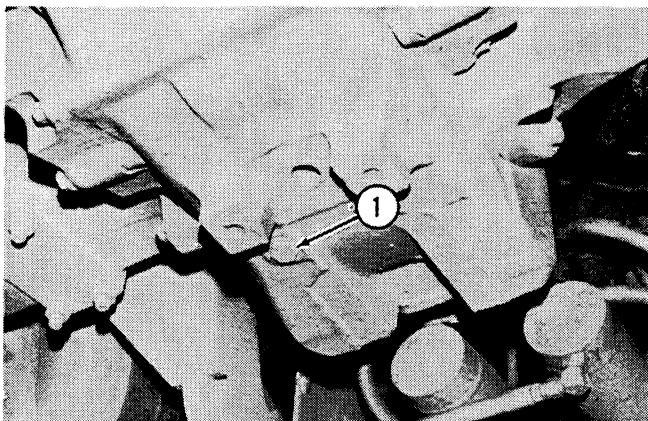

1. Drain Plug

Figure 2

## GENERAL INFORMATION



**THIS SAFETY ALERT SYMBOL INDICATES IMPORTANT SAFETY MESSAGES IN THIS MANUAL. WHEN YOU SEE THIS SYMBOL, CAREFULLY READ THE MESSAGE THAT FOLLOWS AND BE ALERT TO THE POSSIBILITY OF PERSONAL INJURY OR DEATH.**

**CLEANING** - Steam clean the complete exterior of the transmission case before any service work is performed. All metallic parts, except bearings, should be cleaned in mineral spirits or by steam cleaning. Do not use caustic soda solution for steam cleaning. All parts should be dried and lightly oiled after cleaning. Oil passages can be cleaned with compressed air. Bearings should be cleaned in mineral spirits and lightly oiled.

**INSPECTION** - Inspection of all parts should be made when disassembly is required. Any part that shows excessive wear or damage must be replaced. Small nicks or grooves can be removed in most cases with a hone or crocus cloth. Thorough visual inspection for indications of wear, stress, pitting and the replacement of such parts as necessary will eliminate costly and avoidable unit failure.

**GEARS** - Inspect all gears for wear and damage. Gears which are worn, ridged or scored must be replaced. *NOTE:* If it is necessary to replace either the bevel gear (differential ring gear) or pinion shaft, the bevel gear and pinion shaft must be replaced as a matched set.

**SHAFTS** - Inspect all shafts for worn, pitted or broken splines. Also, check for damaged bearing and oil seal surfaces on shafts.

**OIL SEALS, "O" RINGS AND GASKETS** - When installing any parts, always install new gaskets, oil seals and "O" rings. Lubricate rubbing surface of all lip type seals with a lubricant before installation.

**BEARINGS** - Check bearings for free smooth action. If bearings have a loose fit or rough action, replace the bearing. Always replace cup and cone as a set, never just one part of a bearing. Wash bearings with a good solvent and let air dry. **DO NOT SPIN DRY.**

To facilitate assembly in many areas, bearings may be heated. This will expand the bearing inner race, eliminating the need of a hydraulic press when installing bearings over shafts.



**CAUTION** *Always wear asbestos gloves to prevent burning your hands when handling heated parts.*

**NEEDLE BEARINGS** - Always remove any burrs in bore or edge of bore before pressing in needle bearings. Lubricate inside and outside diameter of bearings with a lubricant before pressing into place.

When pressing needle bearings into place, always use a bearing arbor. Place bearing on arbor with stamped end (end with numbers) against stepped shoulder of pressing arbor.

## Countershaft Removal

### STEP 51

Before disassembling the countershaft assembly, the clearance between 2nd and 3rd gear hubs must be measured and recorded for use when the countershaft is reassembled. **NOTE:** Any new part/s that are installed must have their hub thickness measured and compared against the hub thickness of replaced part/s. This will determine spacer thickness required to maintain necessary clearance between gears during assembly.

### STEP 52

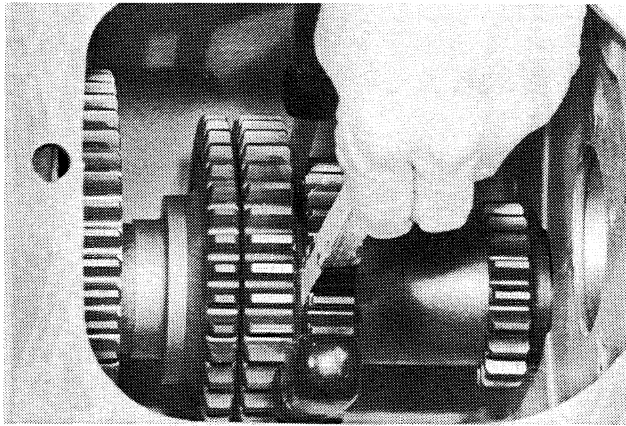

To measure clearance, do not merely tilt the gears on the shaft splines, use two screwdrivers to spread gears apart and check clearance with a feeler gauge.

### STEP 53

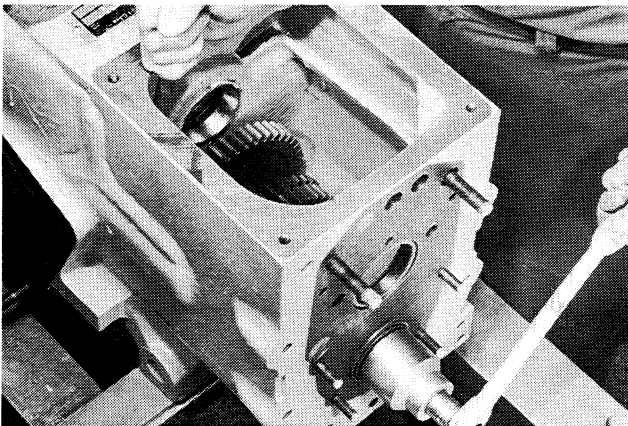

Lock up countershaft gears with a prybar to prevent rotation and loosen the shaft adjusting nut.

### STEP 54

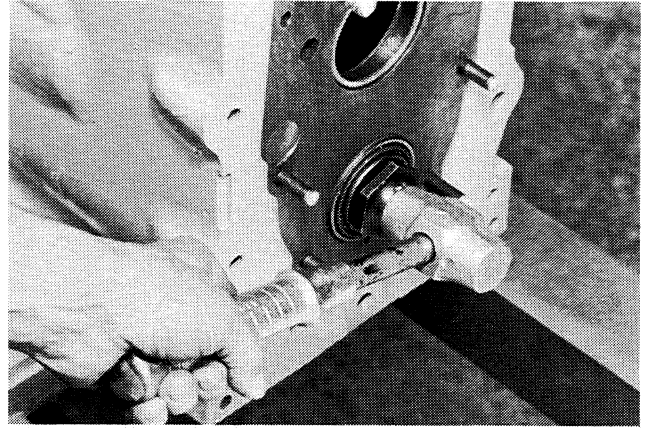

With a soft headed hammer, drive pinion shaft into case.

### STEP 55

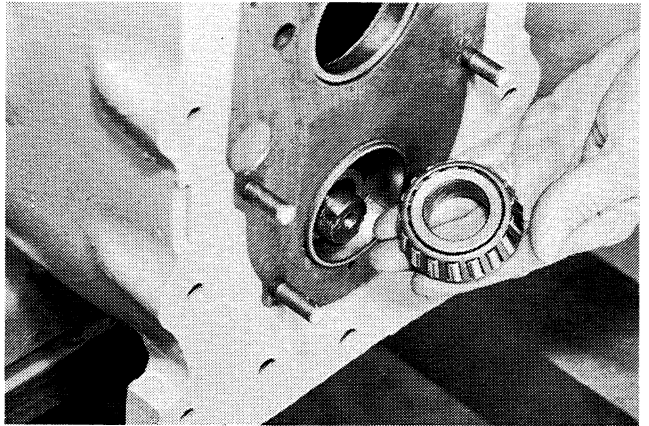

Remove adjusting nut and front bearing cone.

### STEP 56

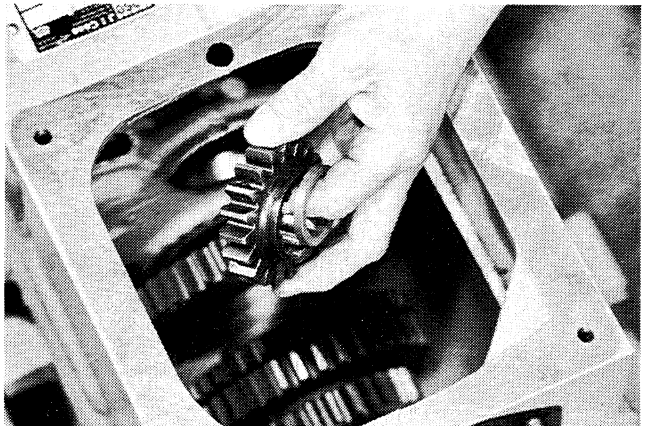

Pull shaft rearward into case, removing gears.

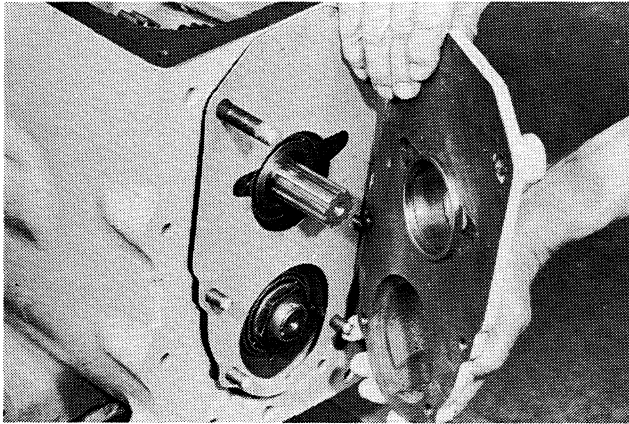
**STEP 109**

Install front cover on housing.

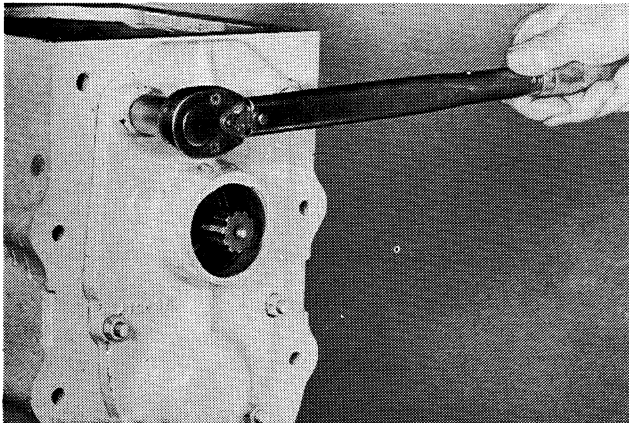
**STEP 110**

Torque front cover 1/2" mounting nuts 80 to 96 ft. lbs. and 3/8" mounting nuts 35 to 42 ft. lbs.

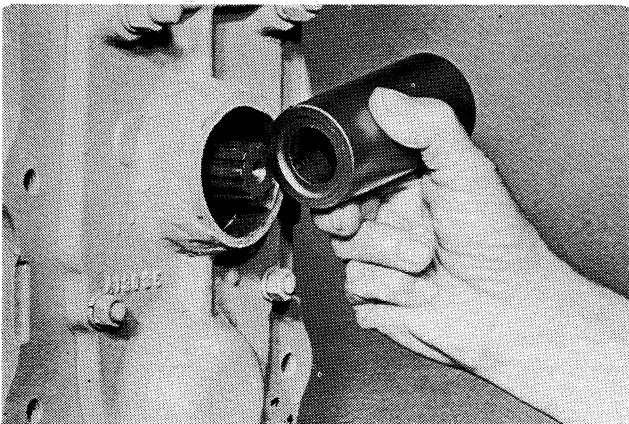
**STEP 111**

Place main front bearing driver A146285 on mainshaft.

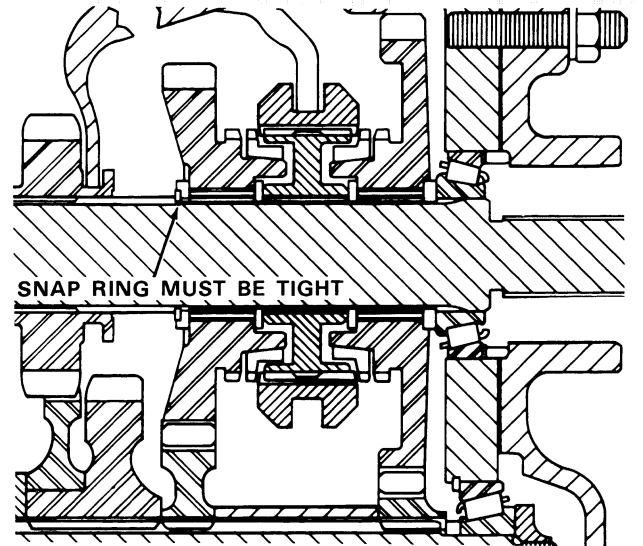
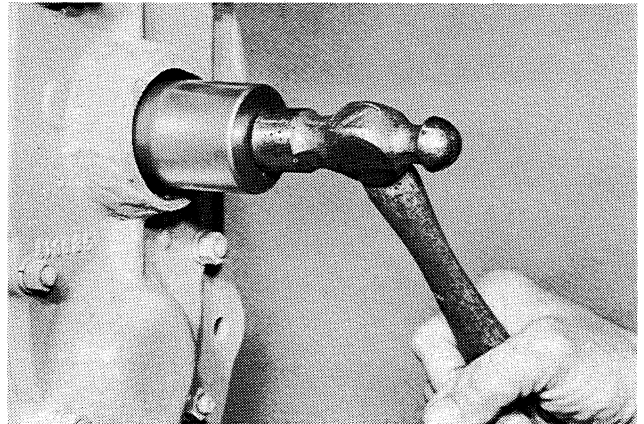
**STEP 112**

Place a wedge between 4th gear and housing. Seat front bearing cone, removing all end play between gears. *NOTE:* End play will be removed when captive snap ring is tight.

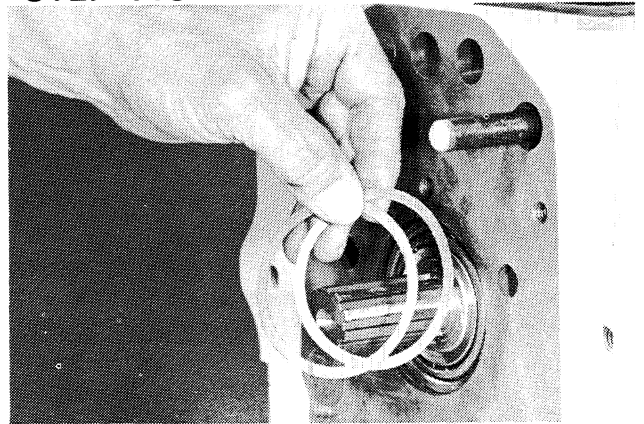
**STEP 113**

Remove the front cover and re-install the old shim pack, retained from Step 37 during disassembly, minus some shims to assure an end play reading.

**STEP 157**

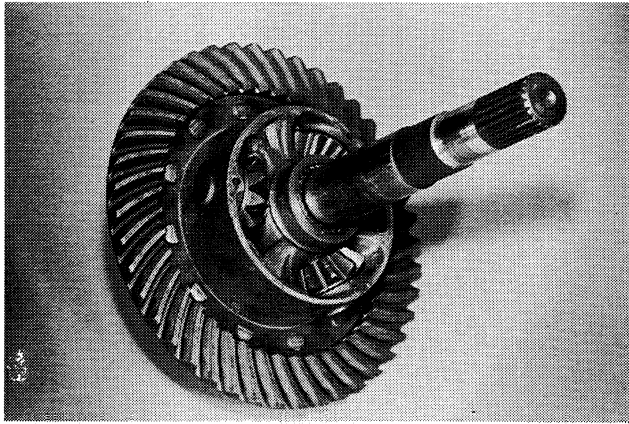

**480C Loader/Backhoe center wheel, ring gear, cross shaft and pinions assembled.**

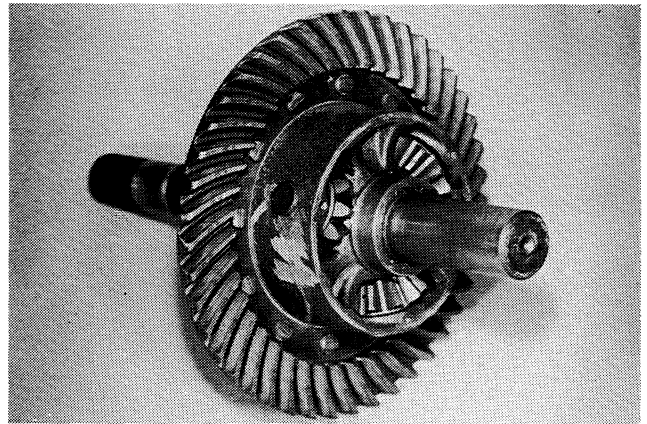

**580C Forklift center wheel, ring gear, cross shaft and pinions assembled.**

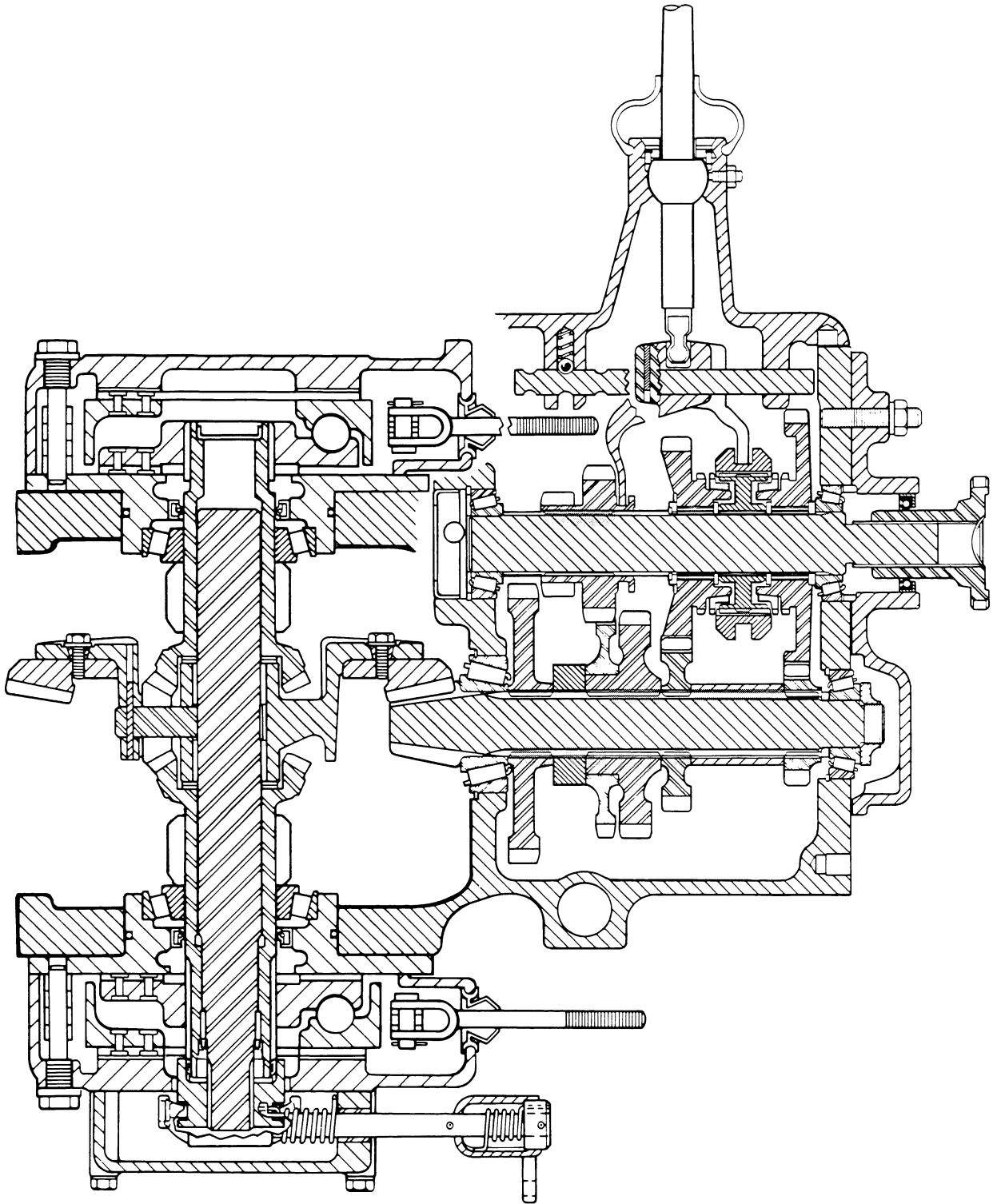

# Section 6222

## DRIVE SHAFT

Written in *Clear  
And  
Simple  
English*

# Section 6229

## WHEELS AND TIRES

Written in *Clear  
And  
Simple  
English*

## PARKING BRAKE ADJUSTMENT

The parking brake adjustment is done with the parking brake lever in the disengaged position. Make sure that the machine is parked on a level surface. Turn the knob on the parking brake lever clockwise several turns to increase the tension. Turn the knob counterclockwise to decrease the tension. Pull park-

ing brake lever into the engaged position and check to make sure that the parking brake will prevent the machine from moving in third gear at 1500 rpm (r/min). Repeat the procedure as necessary until the parking brake works correctly.

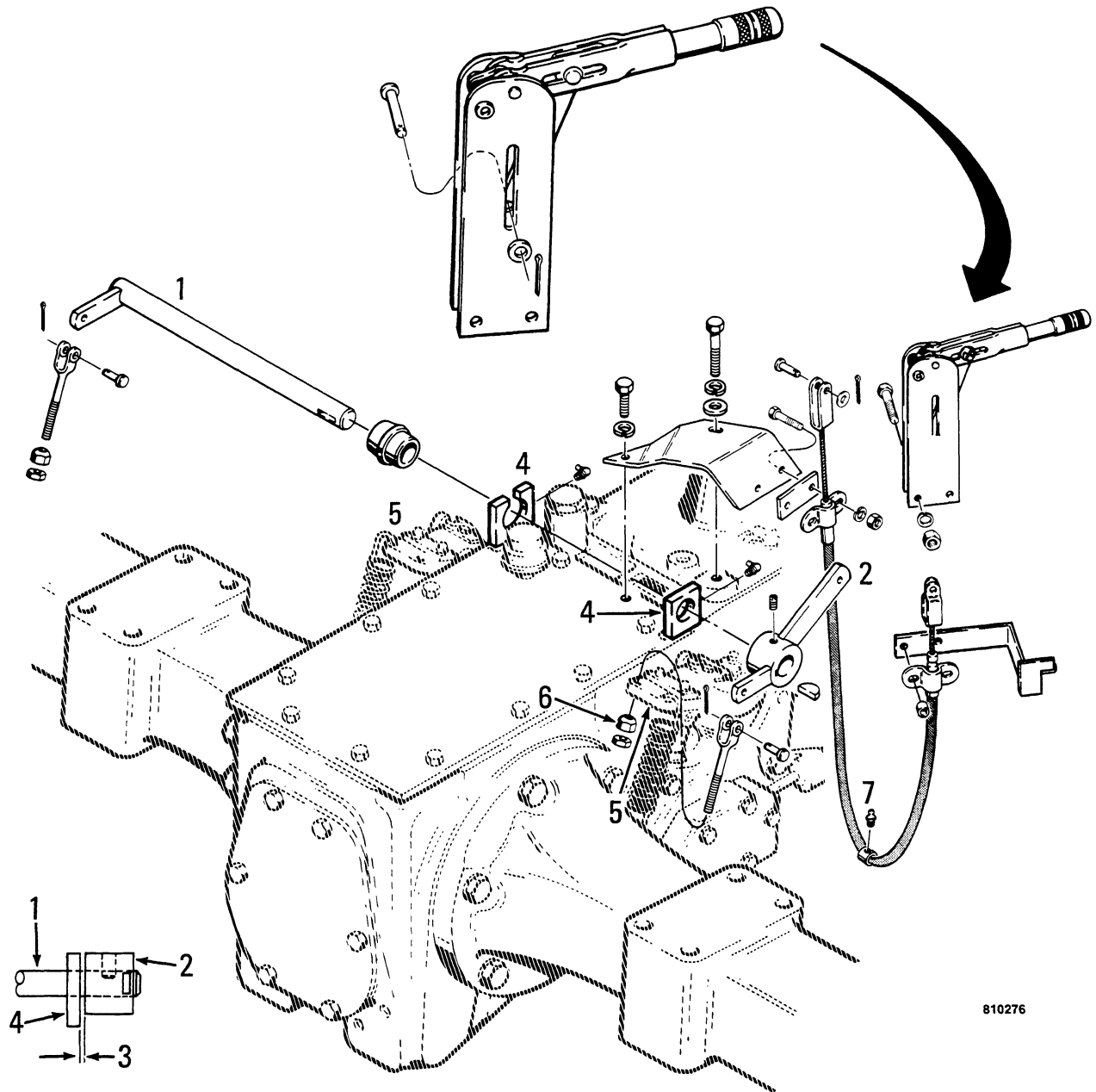

1. SHAFT
2. BRAKE ARM
3. 1/16 TO 1/8 INCH  
(1.5 TO 3 mm)  
CLEARANCE
4. BRACKET
5. BRAKE LEVER

6. ROUND HEAD NUT. WITH PARKING BRAKE HANDLE IN DISENGAGED POSITION, TIGHTEN THE ROUND HEAD NUT UNTIL THE ROUND HEAD NUT TOUCHES THE BRAKE LEVER. LOOSEN ONE TURN. TIGHTEN THE LOCK NUT. THE ROUND HEAD NUT MUST NOT BE IN CONTACT WITH THE BRAKE LEVER
7. GREASE FITTING. USE LUBRIPLATE 105.

810276

Figure 36 - Parking Brake Control Installation

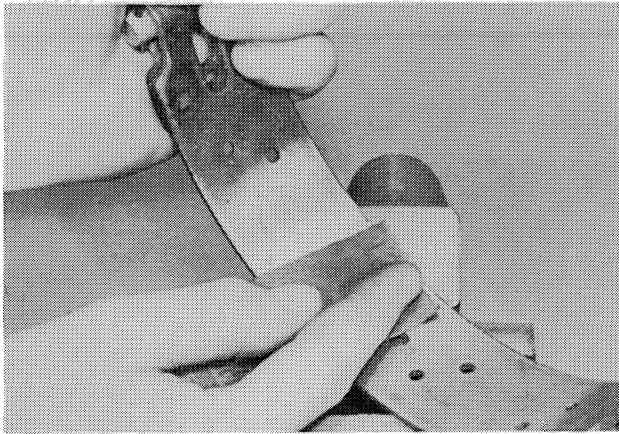
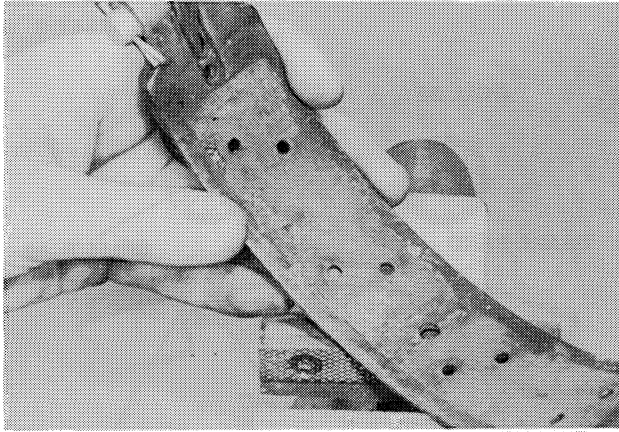
**STEP 23**

Remove rust and scale from brake band. Burrs or nicks must be filed smooth. Check the band for flat spots where cleaning has been done. Flat spots in the area where lining is installed will cause a mismatch of band and brake lining arc. The brake band will have to be replaced.

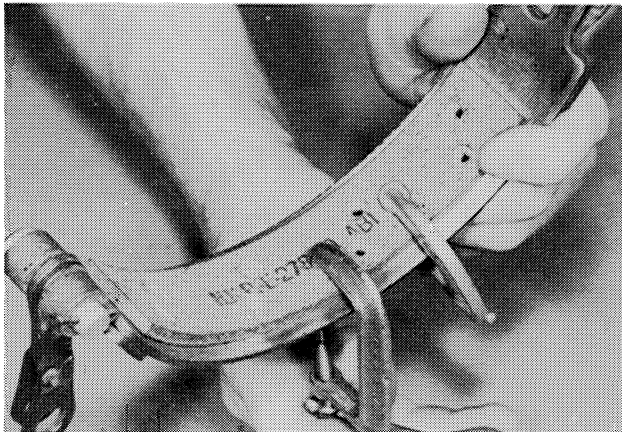
**STEP 24**

Place new lining on brake band and line up rivet holes exact. Clamp the lining tight to the band, placing the clamps close to the rivet holes. Never shim the brake linings. This will cause brake noise because of cracked and loose brake linings and early brake failure.

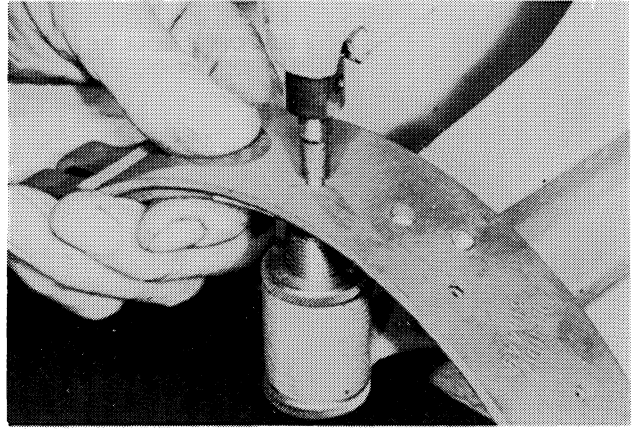
**STEP 25**

Put the brake band and lining on CAS 10520 Brake Rivet Tool. You must set each rivet.

**IMPORTANT:** You must use the correct punch and mandrel for the size rivet to be installed.

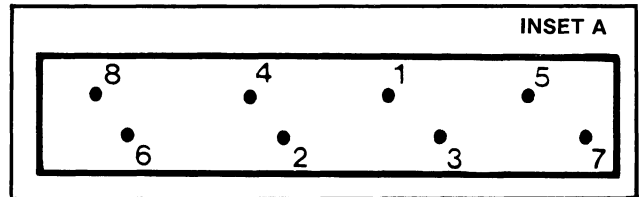

Install the rivets from the lining side, use the pattern shown in inset A.

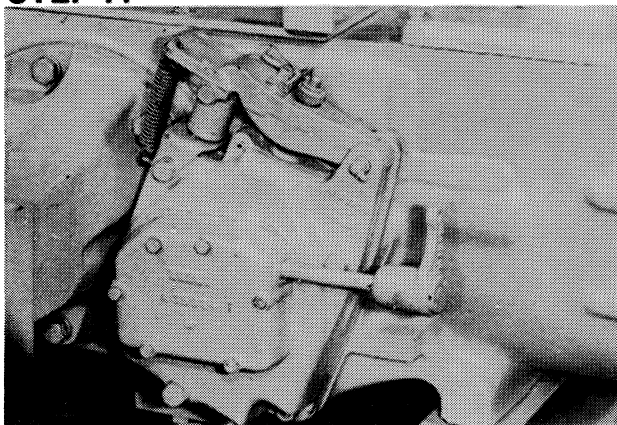
**STEP 77**

**Brake housing installed on transaxle case. Attach linkage and lines to brake cylinder. Refer to Section 7106 for bleeding hydraulic brake cylinder.**

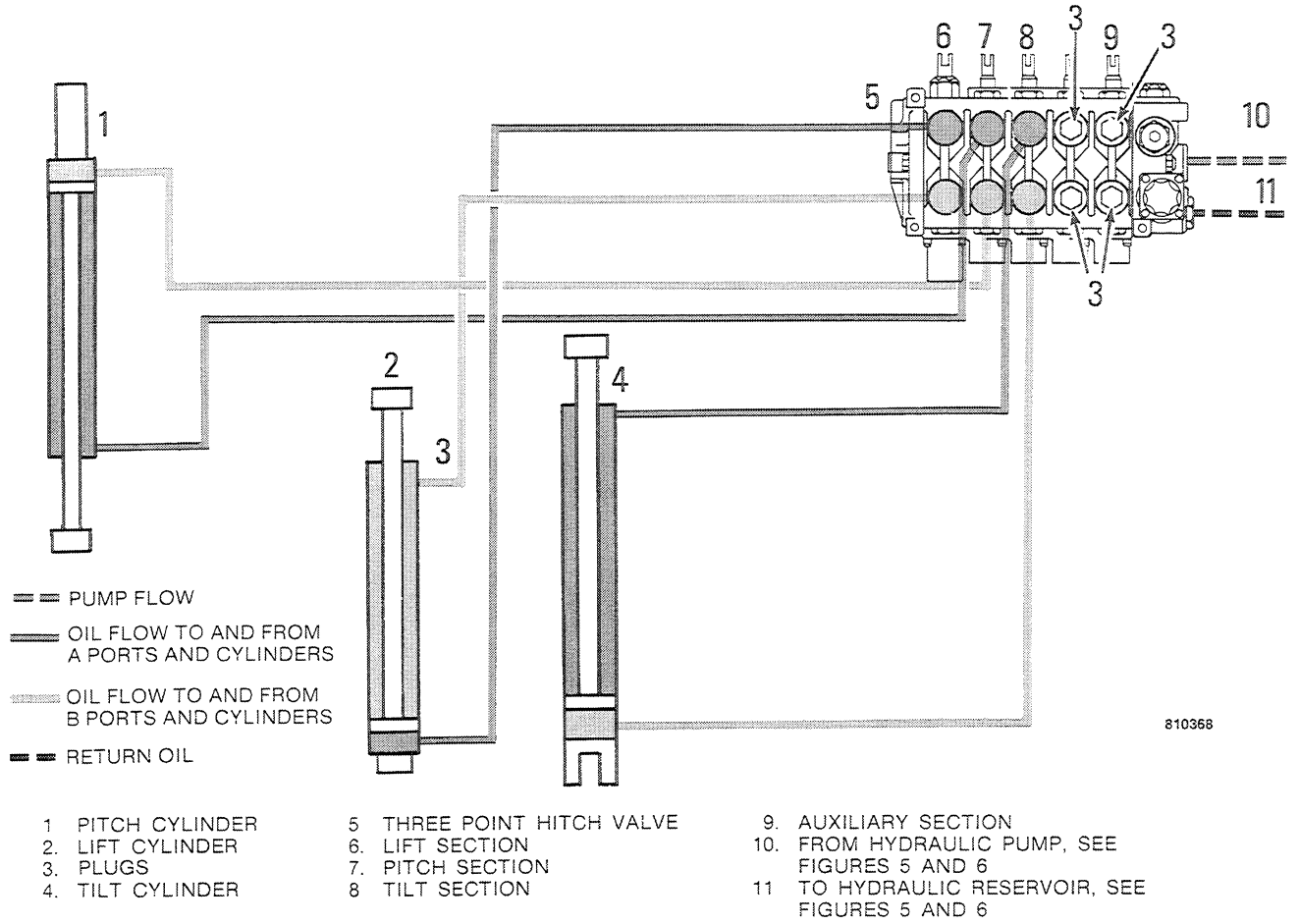

810368

Figure 10 - Three Point Hitch used on Loader/Landscaper Machines

## Bad Performance in All Circuits

CHECK	INSTRUCTIONS
1. Maintenance.	1. Check the pivot points for wear and damage. Make sure that all pivot points are lubricated and move freely. Check the breather for the hydraulic reservoir.
2. Attachments.	2. Check field installed attachments that can be causing poor performance in the hydraulic system.
3. Oil level.	3. Check the level of the oil in the hydraulic reservoir.
4. Drive coupling for the hydraulic pump.	4. Check to make sure that the drive coupling is not broken or damaged.
5. Neutral pressure.	5. See page 8002-33 and measure the neutral pressure in the hydraulic circuit.
6. Check the pressure setting of the main relief valve.	6. See page 8002-27.
7. Check the engine stall speeds.	7. See Section 2003 and do the stall checks to see if the engine is operating correctly.
8. Check the hydraulic system with a flowmeter.	8. See the instructions starting on page 8002-38 and do the flowmeter tests.

## Bad Performance in the Backhoe Circuits or Three Point Hitch Circuits: Loader Circuits Work Correctly

CHECK	INSTRUCTIONS
1. Neutral pressure.	1. See page 8002-33 and measure the neutral pressure in the hydraulic circuit.
2. O-ring on the power beyond fitting in the loader control valve.	2. Remove the power beyond fitting from the loader control valve and check the O-rings on the power beyond fitting.
3. Check the hydraulic system with a flowmeter.	3. See page 8002-38 and do the flowmeter tests to find the cause of the problem.

6. Heat the oil in the hydraulic system to operating temperature by doing the following steps:
  - a. Start and run the engine at full throttle.
  - b. Move the lift control for the three point hitch into the Raise position.
  - c. Hold the lift control in the Raise position for 15 seconds.
  - d. Put the lift control in neutral for 30 seconds.
  - e. Repeat steps 6a through 6d until the hydraulic oil is at operating temperature.
7. Make sure that all control levers are in neutral.
8. Continue to run the engine at full throttle. Look at the pressure gauge. The pressure indication must be less than 200 psi (1379 kPa).
9. If the pressure indication is more than 200 psi (1379 kPa), there is a problem in the hydraulic circuit.
10. Find the cause of the problem by doing the following steps:
  - a. Move each control lever for the three point hitch a short distance in both directions. If the neutral pressure decreases, the spool is not adjusted correctly, or the centering spring for the spool is damaged.
  - b. Disconnect the quick disconnect couplings. Check the quick disconnect couplings for dirt and damage.
  - c. Replace the hydraulic filter and check to make sure that the hydraulic filter head is installed correctly. The point of the arrow on the hydraulic filter head must be toward the left side of the machine.
  - d. Check the neutral pressure again. Make sure that the hydraulic oil is at operating temperature.
  - e. If the neutral pressure is still more than 200 psi (1379 kPa), remove the return lines and check for dirt or other restrictions.

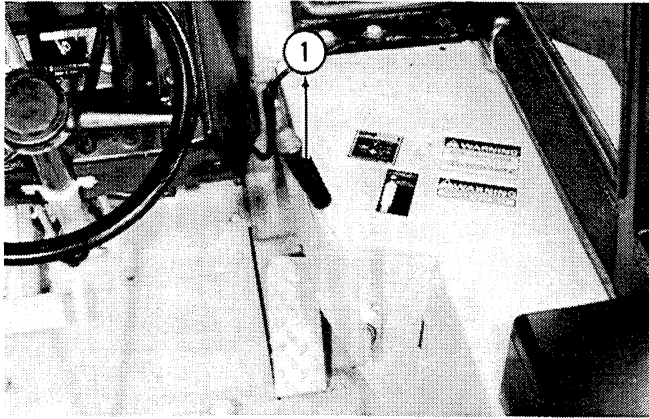

1. Lower  
Figure 81 - Single Lever Control

25. Hold the loader control lever in the Lower position and adjust the pressure valve until the pressure gauge indicates 1800 psi (12 410 kPa). Keep the engine running at 2000 rpm (r/min). Read the flow gauge.

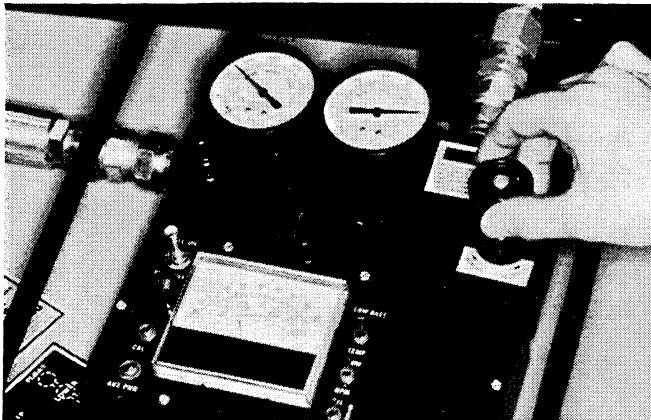

Figure 82

26. Write the flow gauge indication on the check sheet.

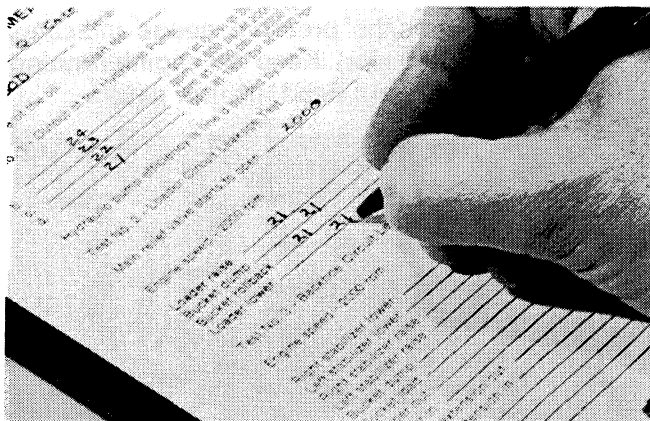

Figure 83

27. Open the pressure valve completely.



Figure 84

28. Decrease the engine speed to low idle. Stop the engine.

### Understanding the Results of the Test

1. If the flow indication for each circuit was within 1 gpm (4 L/min) of the flow indication at 1800 psi (12 410 kPa) in Test No. 1, the circuit is good.
2. If the flow indication for all circuits was more than 1 gpm (4 L/min) less than the flow indication at 1800 psi (12 410 kPa) in Test No. 1, the main relief valve is probably the cause. Repair or replace the main relief valve as necessary.
3. If the flow indication for a circuit was lower than the flow indication at 1800 psi (12 410 kPa) in Test No. 1, there is leakage in that circuit. See Bad Performance in a Single Circuit, starting on page 8002-17, and find the cause of the problem.

47. Write the flow gauge indication on the check sheet.

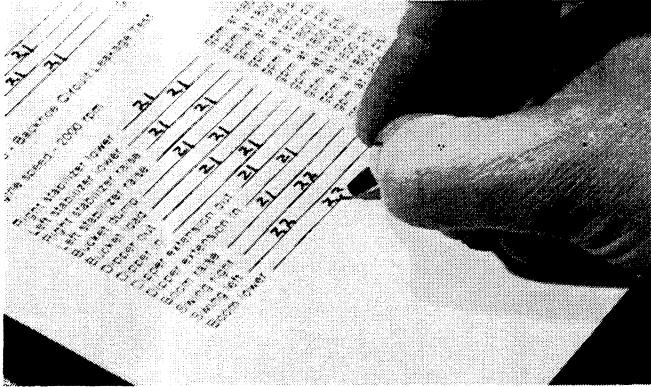

Figure 128

48. Open the pressure valve completely.

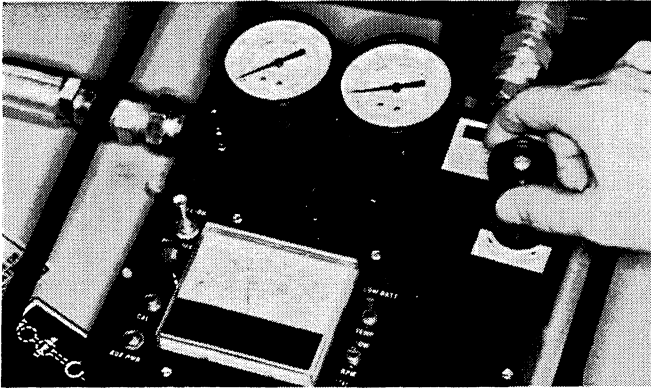

Figure 129

49. Decrease the engine speed to low idle. Stop the engine.

## Understanding the Results of the Test

1. If the flow indication for each circuit was within 1 gpm (4 L/min) of the flow indication in Test No. 1 at the same pressure, the circuit is good.
2. If the flow indications for all circuits were low, the O-ring on the power beyond fitting is probably damaged. Remove the power beyond fitting from the loader control valve and replace the O-ring.
3. If the flow indications were low for all circuits except the stabilizers and the boom down circuit, the O-ring on the load check valve for the boom down circuit is probably damaged. Remove the load check plug and check the O-ring.
4. If the flow indication for a circuit was more than 1 gpm (4 L/min) less than the flow indication at the same pressure in Test No. 1, there is leakage in that circuit. Probable causes of leakage include the following:
  - a. Secondary relief valve.
  - b. Spools in the control valve.
  - c. Cylinder packing.
  - d. O-rings on the load check valves.
5. If the flow indication for a swing circuit or for a boom down circuit was low, see Bad Performance in a Single Circuit starting on page 8002-17.
6. If the flow indication for a stabilizer circuit was low, the leakage can be normal. Because of the design of the stabilizer control valve, there can be leakage by the spools in the valve. To learn whether or not the leakage is normal, do the following steps:
  - a. Look at the check sheet and find the bucket circuit that had the highest flow indication.
  - b. Move the bucket control lever to actuate that bucket circuit.
  - c. Repeat steps 2 through 17 in Test No. 3 while you hold the bucket control lever in position.
  - d. If the stabilizer circuit is still bad, the leakage is not normal. See Bad Performance in a Single Circuit, starting on page 8002-17, and find the cause of the leakage.
  - e. If the stabilizer circuit is good while you held the bucket control lever in position, the leakage is normal and the stabilizer circuit is good.
7. If the flow indication for the bucket, dipper, dipper extension, or the boom raise circuit was low, check the circuit again at 1200 psi (8274 kPa).
  - a. If the flow indication is within 1 gpm (4 L/min) of the flow indication at 1200 psi (8274 kPa) in Test No. 1, the pressure setting of the secondary relief valve is probably too low. See page 8002-36 and check the pressure setting of the secondary relief valve.
  - b. If the flow indication is more than 1 gpm (4 L/min) less than the flow indication at 1200 psi (8274 kPa) in Test No. 1, the secondary relief valve is probably good. See Bad Performance in a Single Circuit and check the other probable causes of leakage.

# Section 8005

## HYDRAULIC PUMP

Written In *Clear  
And  
Simple  
English*

13. Put the thrust plate on the gear shafts. Put the bronze side of the thrust plate next to the gears.

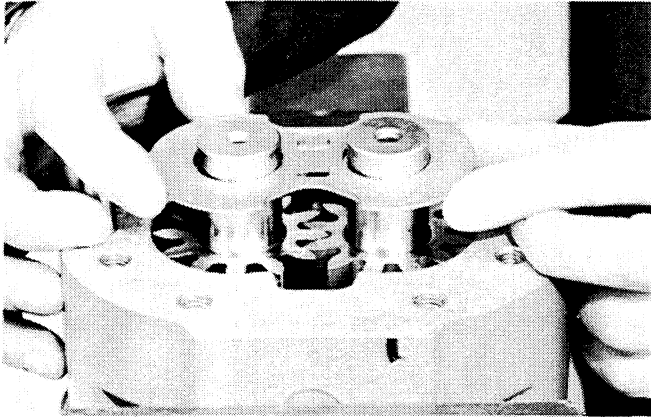

Figure 34

14. Put the port end cover in position on the drive end cover.

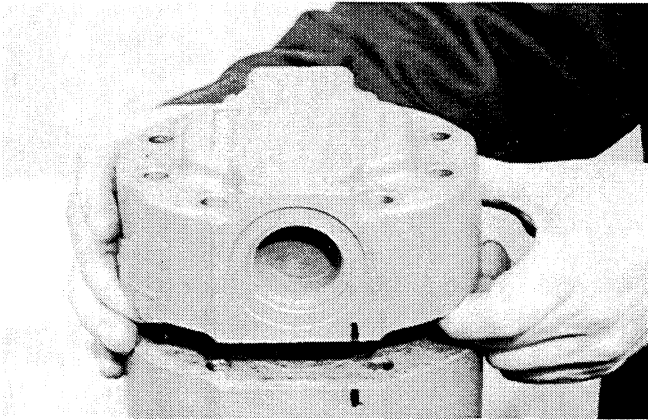

Figure 35

15. Install the washers and cap screws.

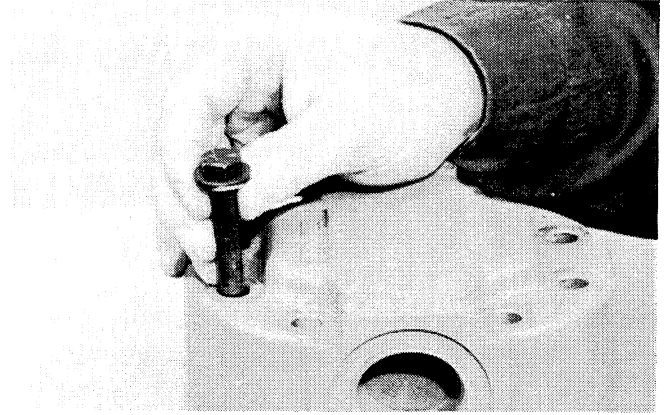

Figure 36

16. Torque the cap screws to 28 - 32 pound-feet (38 - 43 N m).

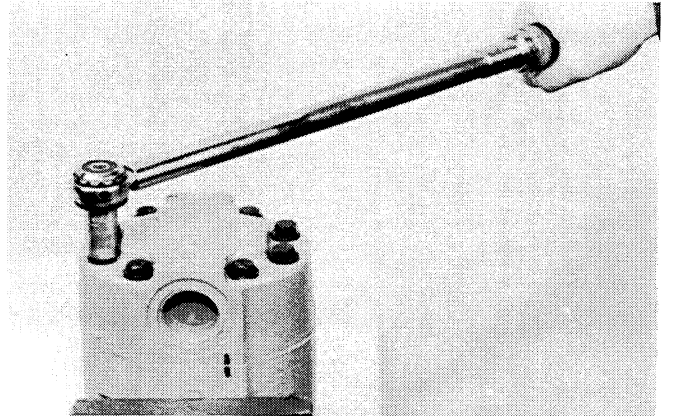
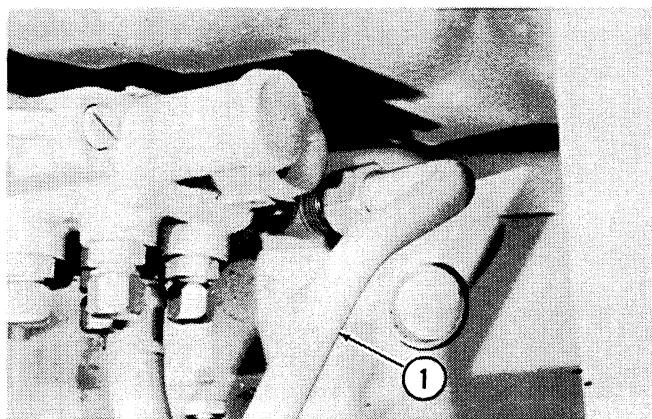

Figure 37

17. Use an acceptable tool and turn the shaft six revolutions. The pump shaft must almost be free enough to turn by hand. Resistance must be approximately equal through the complete rotation. If the resistance is not equal, disassemble the pump to find the cause.

13. Tighten the tube to the fitting in the loader control valve.



1. Tube

Figure 46

14. Tighten the other end of the tube to the fitting.

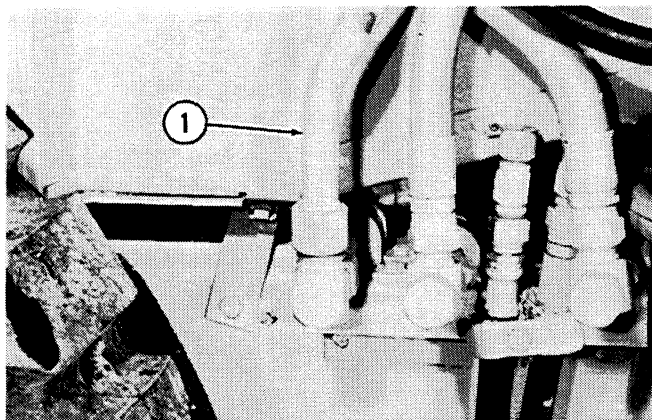

1. Tube

Figure 47

15. Remove the cap from the fitting. Remove the plug from the hose.

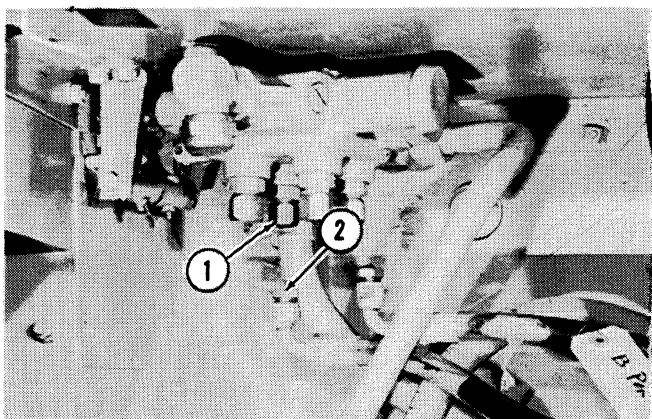

1. Cap  
2. Plug

Figure 48

16. Connect the hose to the fitting.

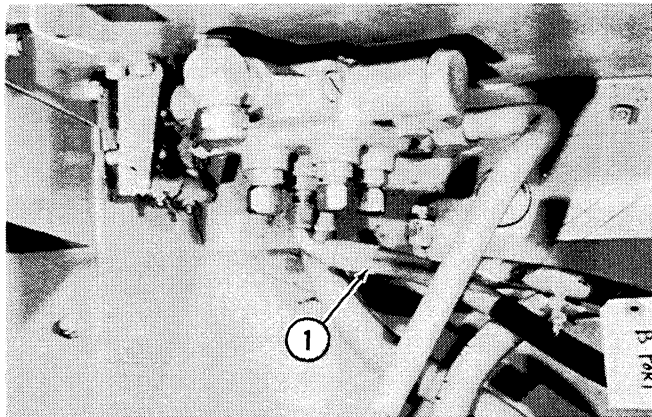

1. Hose

Figure 49

17. Remove the cap from the fitting. Remove the plug from the hose.

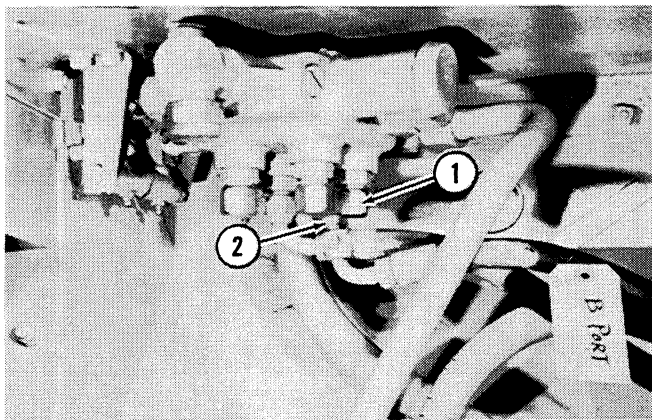

1. Cap  
2. Plug

Figure 50

18. Connect the hose to the fitting.

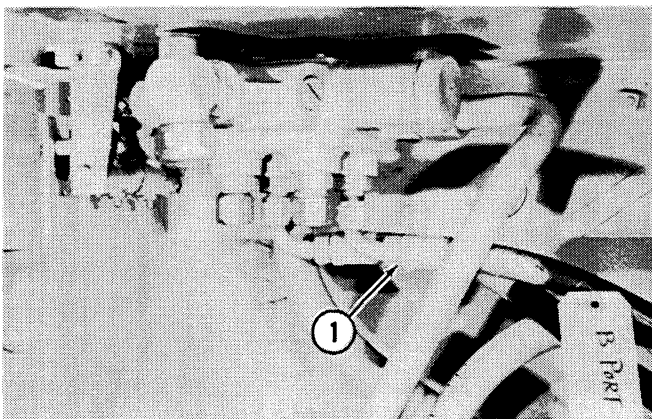

1. Hose

Figure 51

## Bucket Spool

### Disassembly

1. Put the loader control valve on a clean bench. Make sure that the outside of the loader control valve is clean.

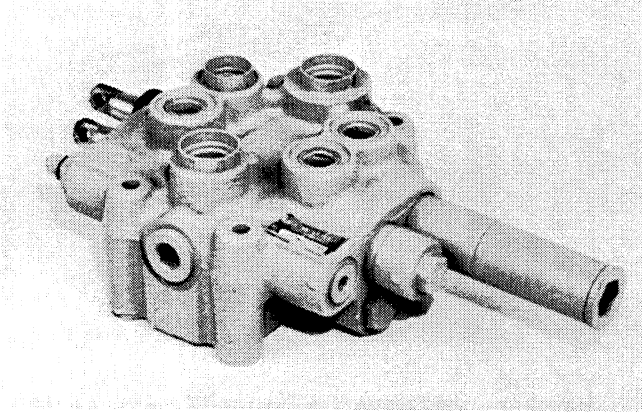

Figure 75

2. Put numbers on the body to make sure that the parts can be installed correctly.

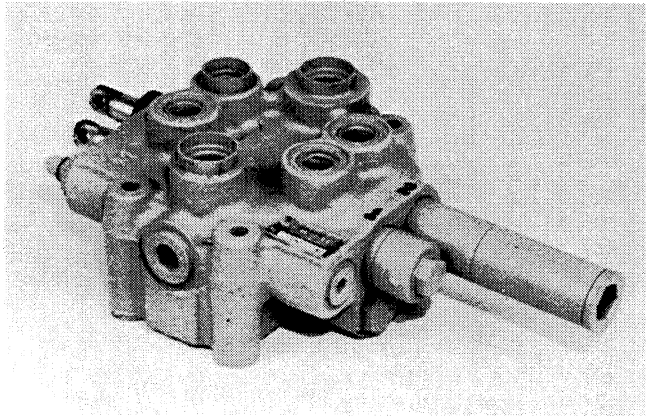

Figure 76

3. Loosen and remove the spring cap.

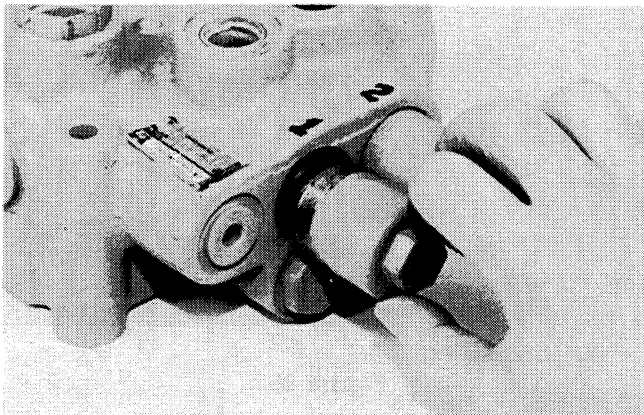
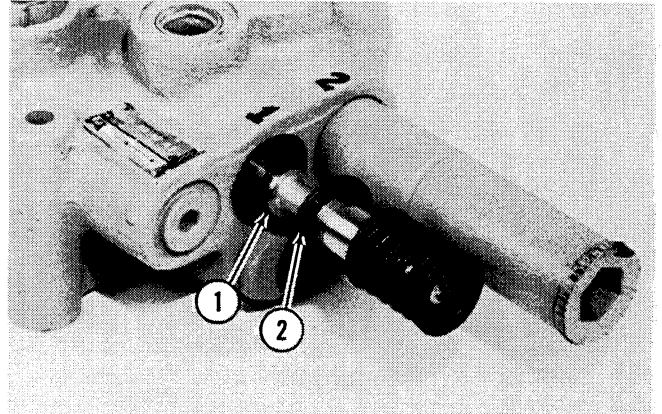

Figure 77

4. Pull the spool from the body. Make sure that the washer and O-ring are also removed from the body.



1. O-ring
2. Washer

Figure 78

5. Use the tool shown in Figure 66 to loosen the gland.

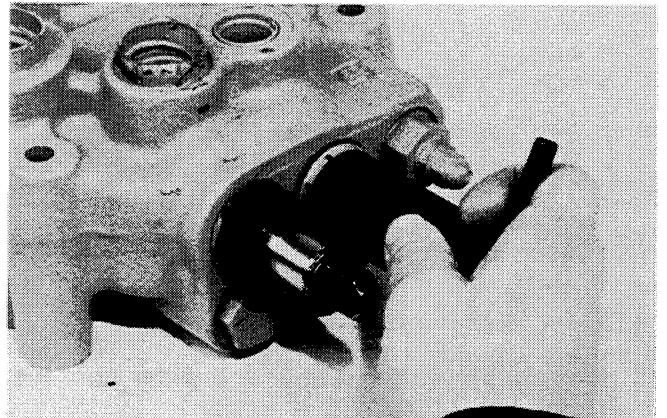

Figure 79

6. Remove the gland.



Figure 80

11. Hit the retainer with a hammer until the retainer is even with the end of the gland.

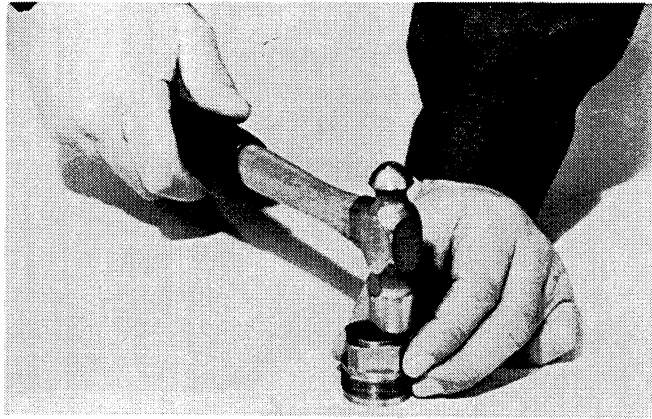
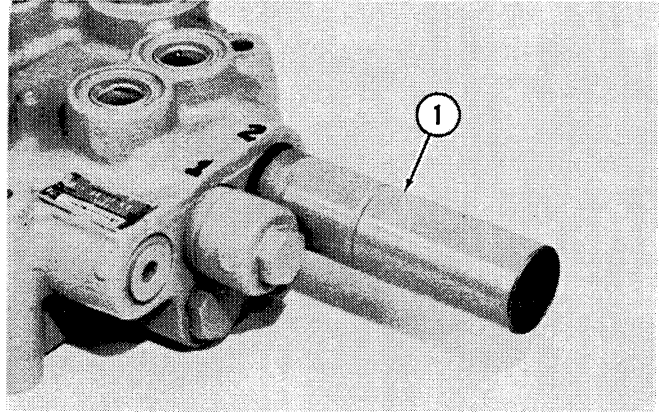

Figure 139

14. Install the detent housing.



1. Detent Housing  
Figure 142

12. Install a new O-ring on the inner retainer. Put clean oil on the spool and O-ring. Install the spool into the body.

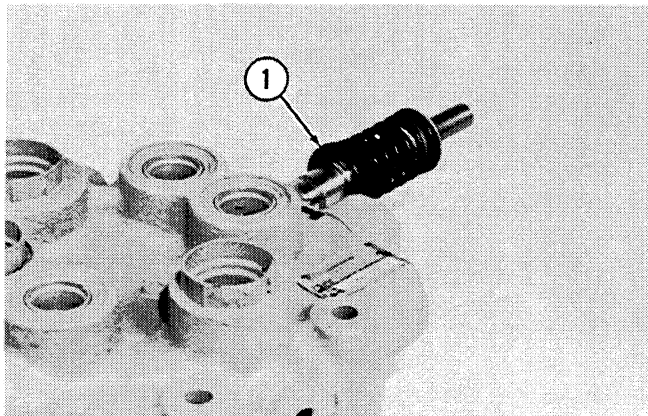

1. O-ring  
Figure 140

15. Put the loader control valve in the vise with soft jaws.

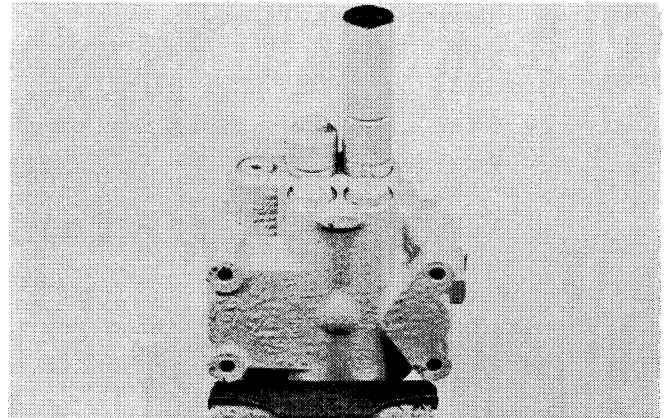

Figure 143

13. Push the spool into the body.

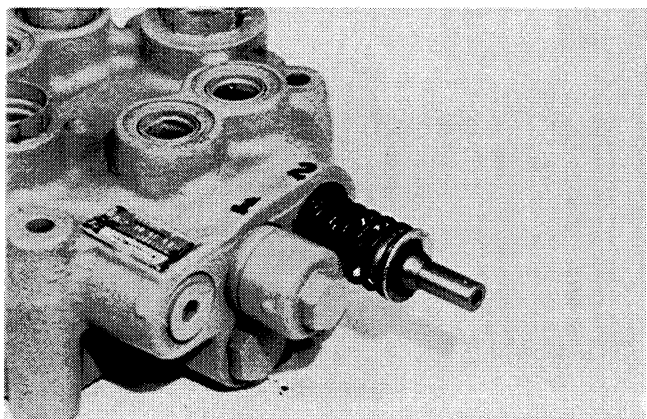

Figure 141

16. Install the washer.

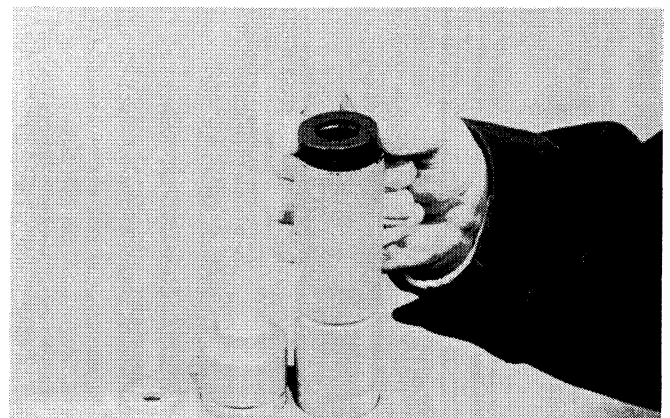
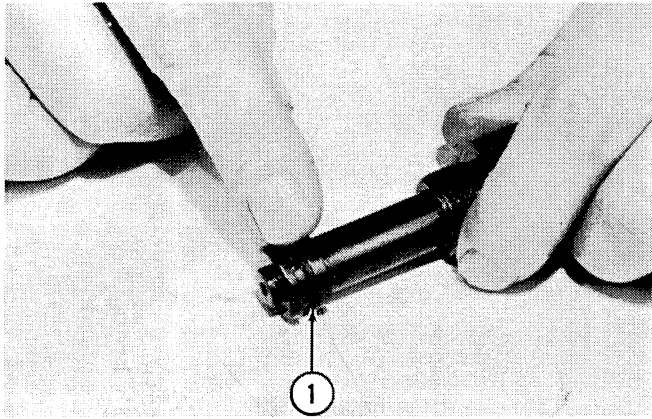
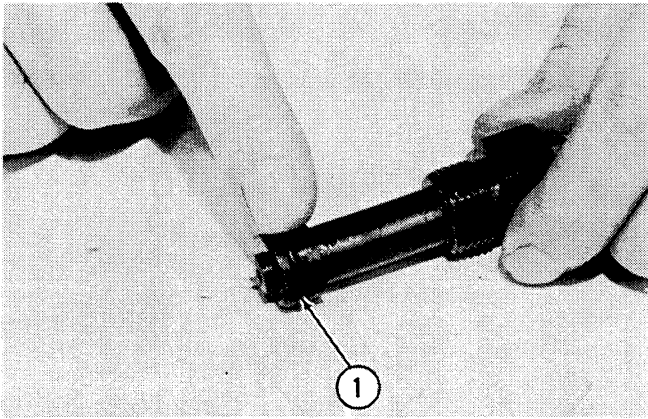

Figure 144

28. Install new O-rings and backup rings on the body.



1. Backup Ring  
Figure 197



1. O-ring  
Figure 198

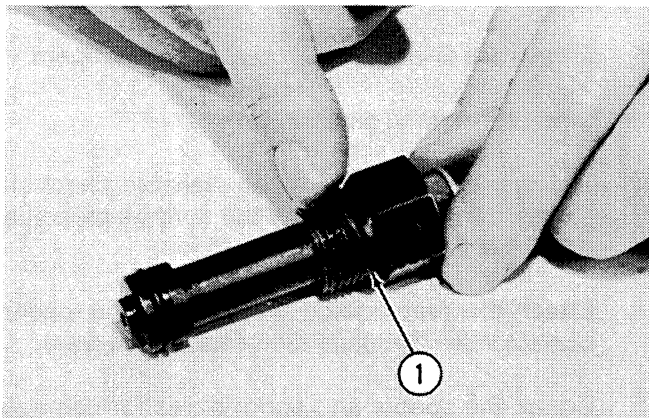

1. O-ring  
Figure 199

29. Put clean oil on the poppet. Install the poppet into the body.

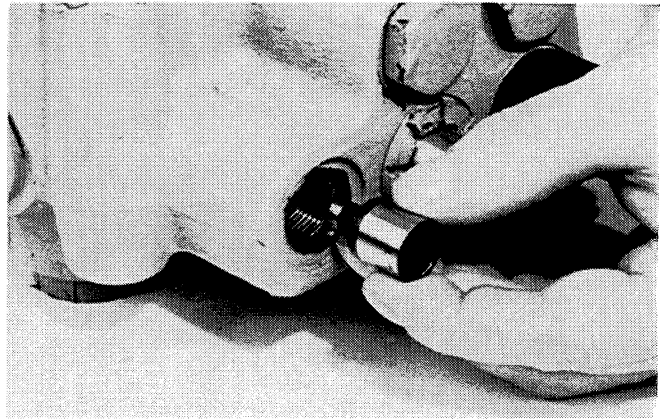

Figure 200

30. Install the spring into the poppet.

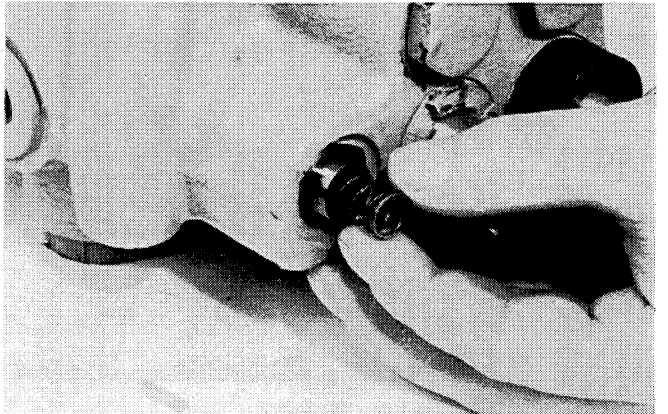

Figure 201

31. Put clean oil on the O-rings and backup rings. Install the body assembly.

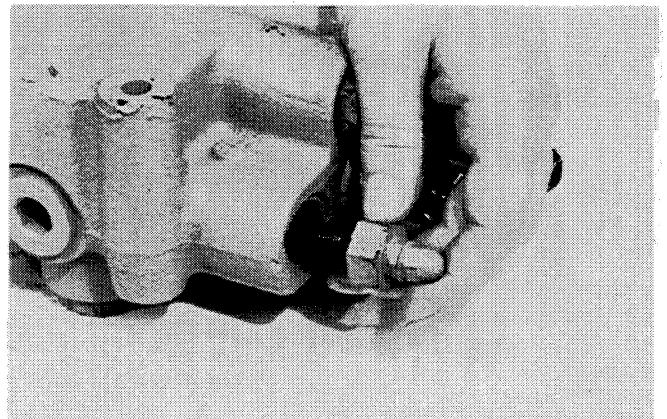

Figure 202

11. Install the stop disc.

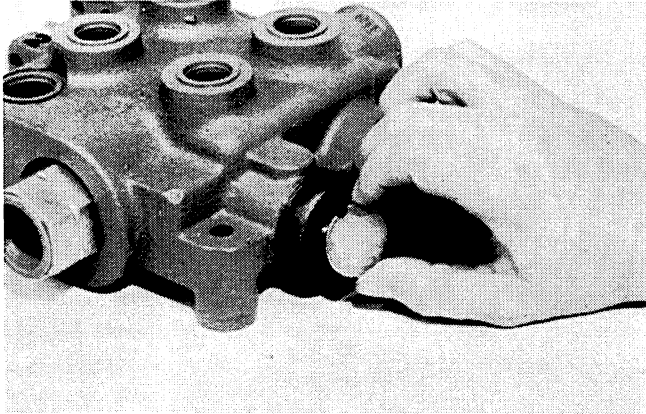

Figure 237

12. Install the snap ring.

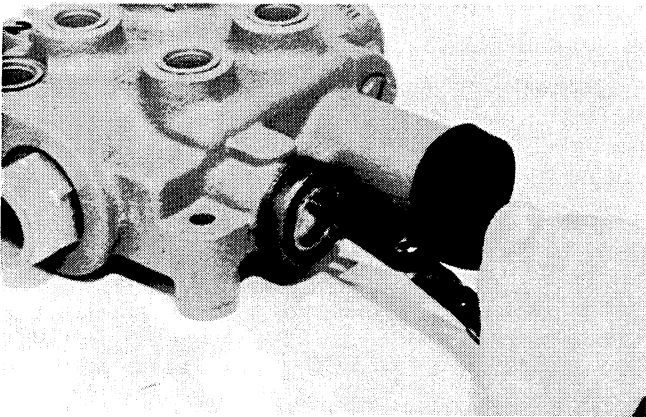

Figure 238

13. Install the rubber cap.

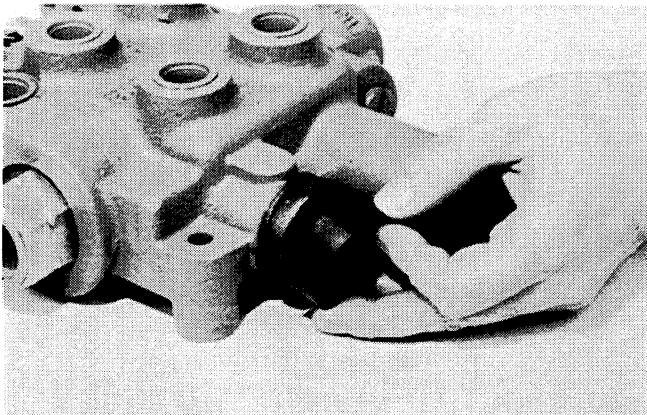

Figure 239

## Lift Spool

### Disassembly

1. Put the loader control valve on a clean bench. Make sure that the outside of the loader control valve is clean.

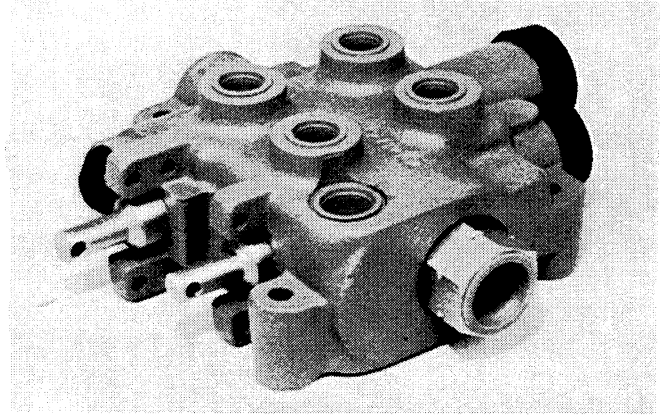

Figure 240

2. Put numbers on the body of the loader control valve so that the parts can be installed correctly.

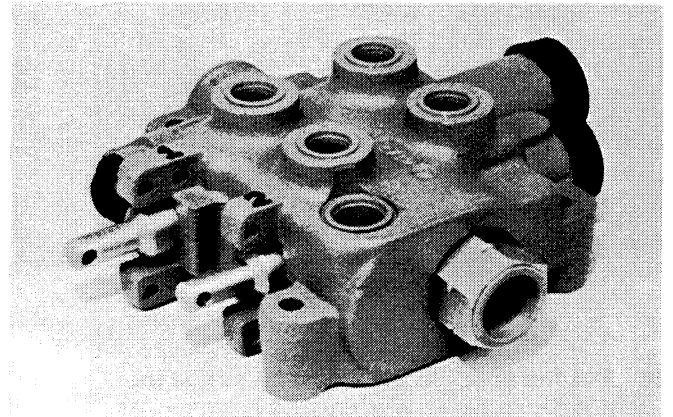

Figure 241

3. Remove the rubber cap from the body.

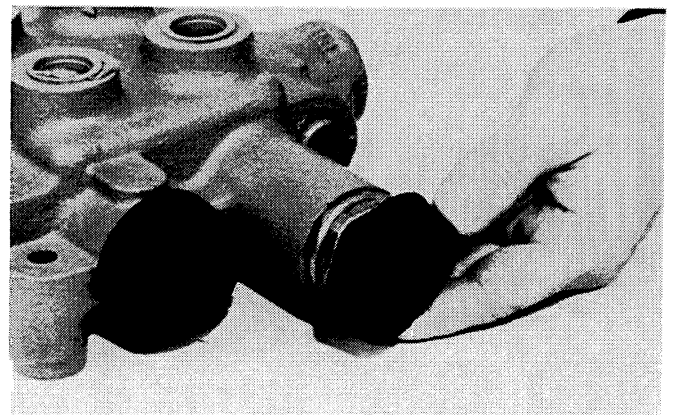

Figure 242

# Section

# 8008

## PUMP PROTECTION VALVE AND QUICK DISCONNECT COUPLINGS

Written In *Clear  
And  
Simple  
English*

17. Install a seal washer on the top of the lock nut.

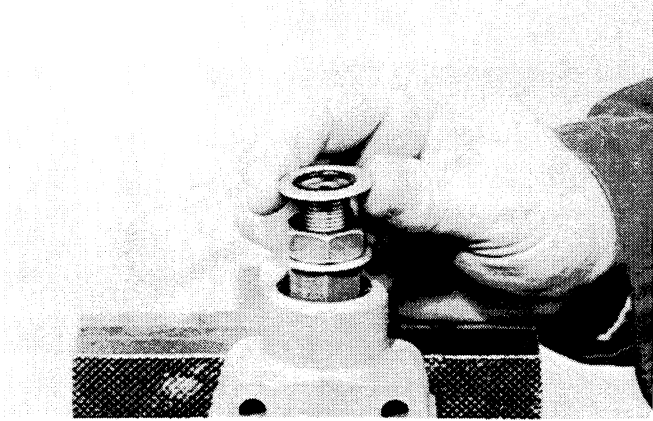

Figure 47

18. Install and tighten the dome nut.

## SPECIFICATIONS

### Torque

Tie bolts and nuts .....	29 - 35 pound-feet (39 - 47 N m)
Hex head screws .....	11 - 13 pound-feet (15 - 18 N m)
Relief valves and plugs .....	18 - 22 pound-feet (24 - 30 N m)
Screws (spring caps and brackets) .....	4.5 - 5.5 pound-feet (6 - 7 N m)
Set screw for knob .....	15 - 25 pound-inches (2 - 3 N m)

## GENERAL INFORMATION

The three point hitch control valve can have 1, 4, or 5 spools in addition to an inlet/outlet section and end section.

1 spool (lift) .....	480D mechanical hitch
4 spool (lift, pitch, tilt, implement) .....	480D hydraulic hitch
5 spool (lift, pitch, tilt, 2 implement) .....	480LL hydraulic hitch

### Passages in the Control Valve

The three point hitch control valve has an open center passage and a parallel passage. The open center passage starts at the first spool section and is connected to the return passages in the end cover. The parallel passage starts at the inlet/outlet section and ends at the end cover. Oil from the pump flows through both passages.

The parallel passage lets more than one cylinder be actuated at one time. The cylinder that is working against the smallest resistance will move first.

The open center passage lets hydraulic fluid return to the hydraulic reservoir when all the spool sections are in neutral.

Return hydraulic fluid flows to the outlet port through the return passages at the top and bottom of the valve sections.

### Valves

An adjustable flow control valve, 3 - 8 gpm (11.4 - 30.3 L/min), is located in the inlet/outlet section. The flow control valve allows the adjustment of hydraulic fluid to the three point hitch control valve. This adjustment of hydraulic fluid will control the speed of the three point hitch cylinders.

An adjustable flow control valve, 3 - 8 gpm (11.4 - 30.3 L/min), is located in the inlet/outlet section. The flow control valve allows the adjustment of hydraulic fluid to the three point hitch control valve. This adjustment of hydraulic fluid will control the speed of the three point hitch cylinders.

A secondary relief valve is connected between the A port and the return passage in the lift section. The secondary relief valve gives protection to the lift circuit when the cylinder is moved with the valve spool in neutral.

Load check valves between the parallel passage and the A port and B port prevent the reverse flow of hydraulic fluid between the cylinders and the three point hitch control valve when a spool is moved into a power position.

## SEPARATING THE CONTROL VALVE SECTIONS

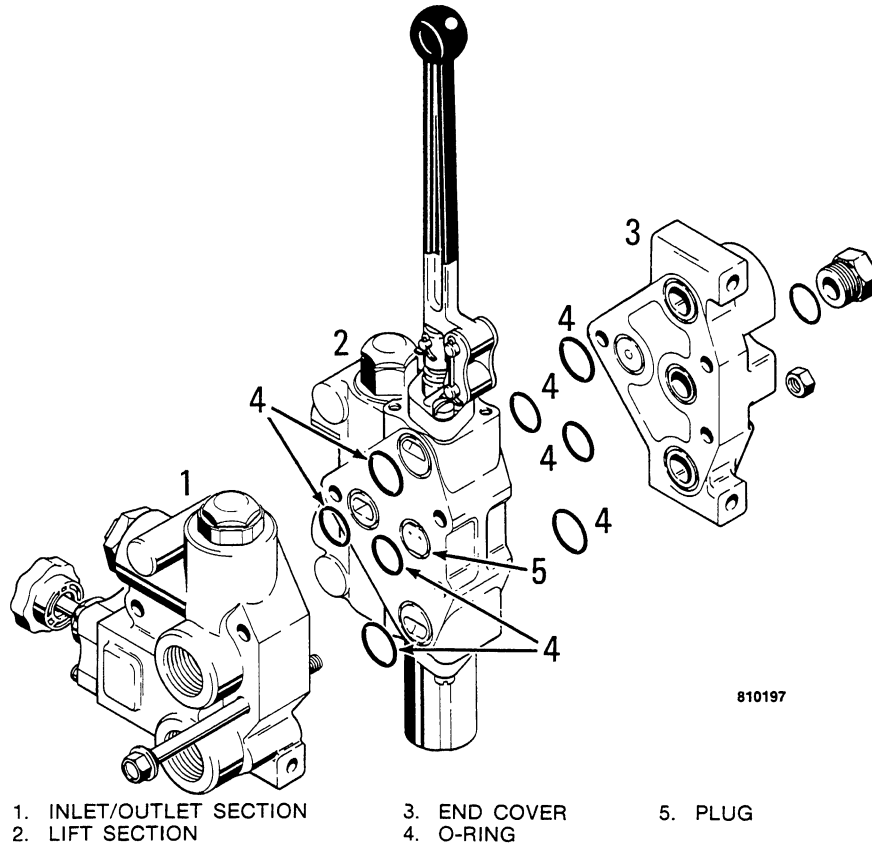

Figure 10 - Three Point Hitch Control Valve with One Spool

### Three Point Hitch Control Valve with One Spool

#### Disassembly

1. Clean the control valve and put the control valve on the bench.

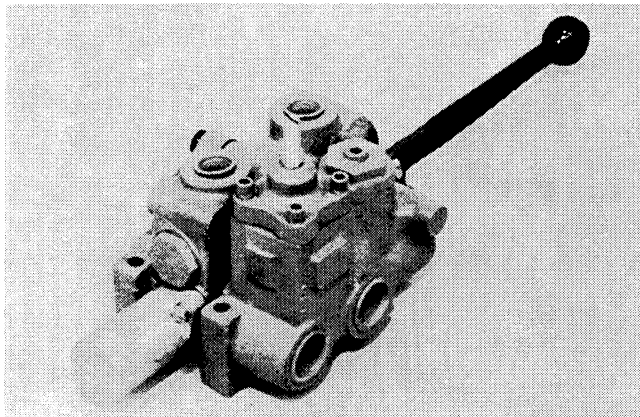

Figure 11

2. Write numbers on each section of the control valve.
3. Loosen and remove the nuts from the bolts that hold the sections together.

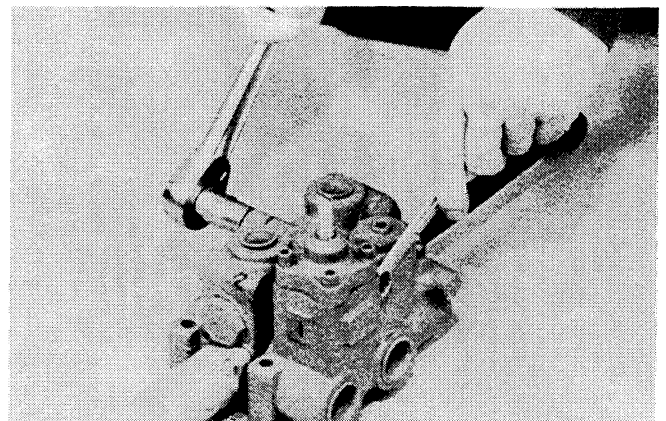

Figure 12

7. Install the other auxiliary section.

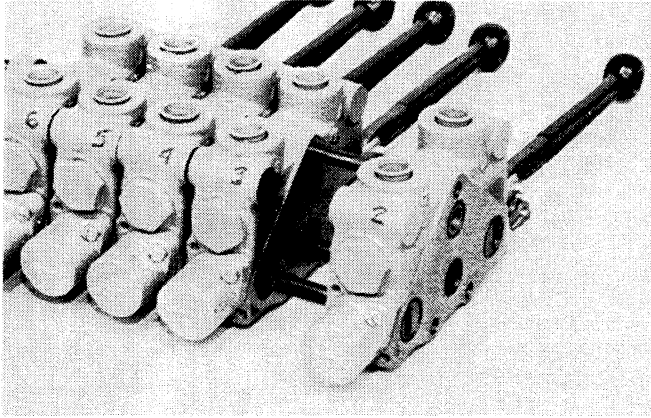

Figure 69

9. Install the inlet/outlet section.

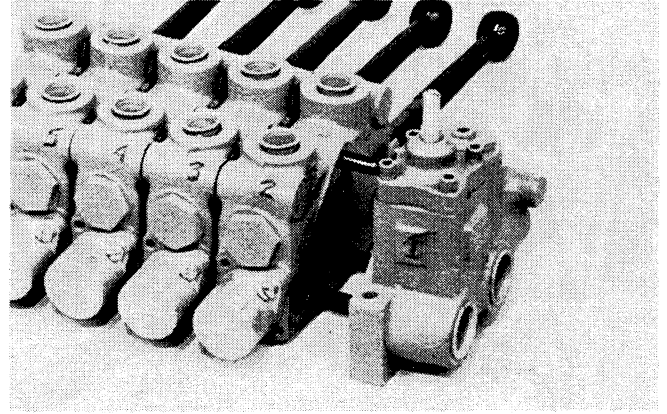

Figure 71

8. Install the plug in the open center passage of the auxiliary section.

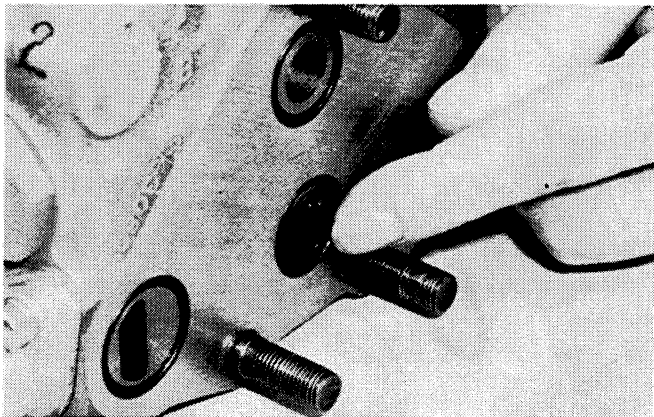

Figure 70

10. Install and tighten the nuts. Torque the nuts to 29 - 35 pound-feet (39 - 47 N m).

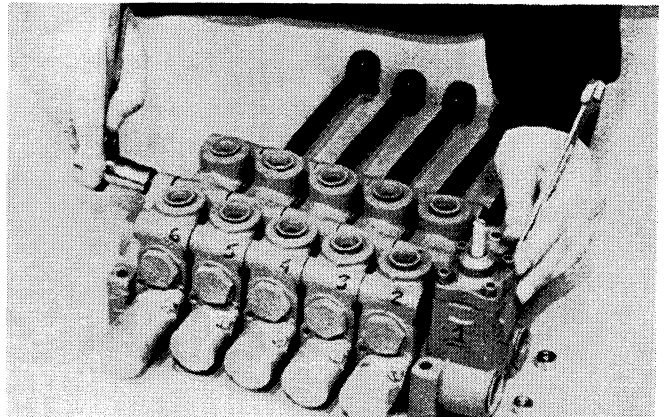
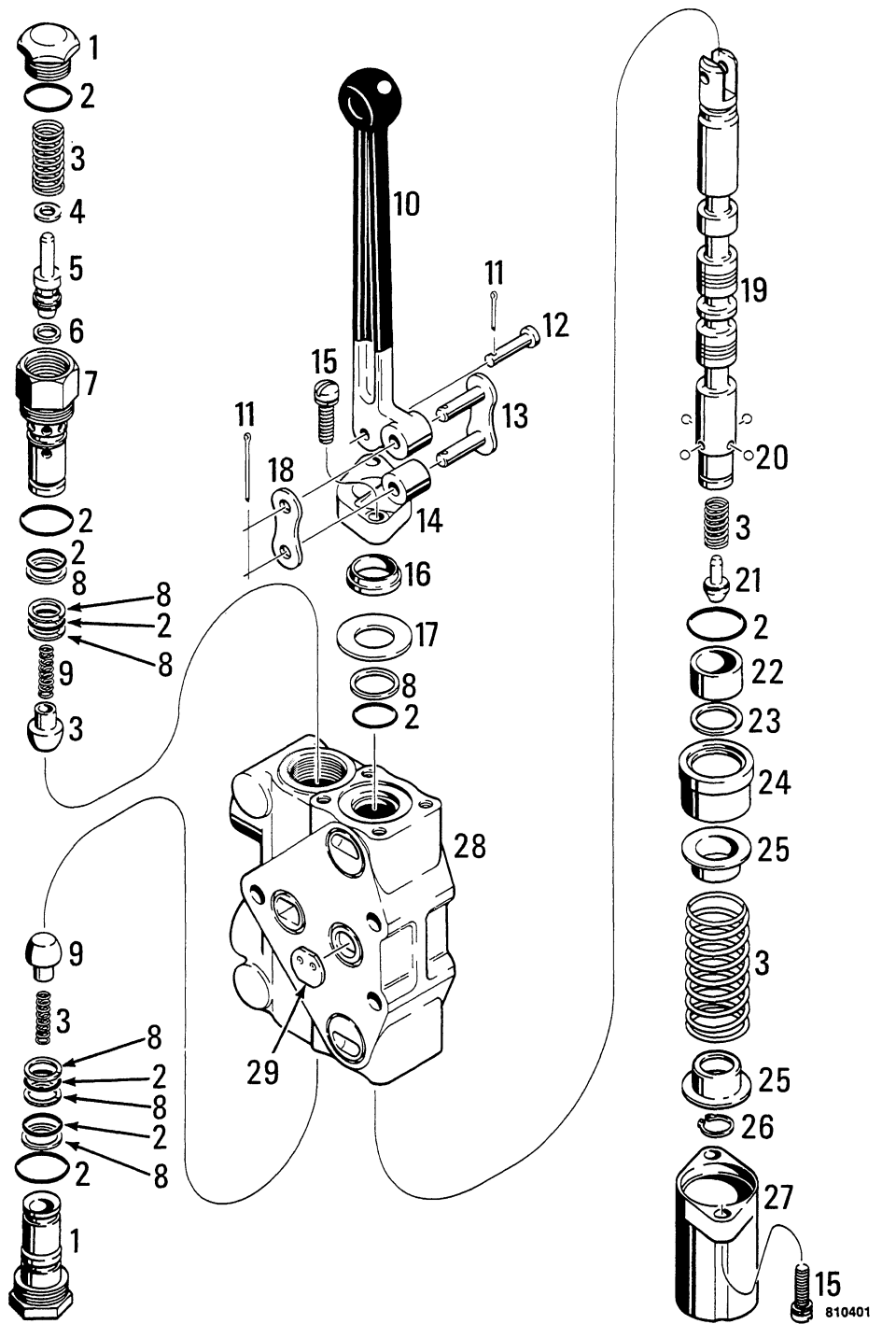

Figure 72



- |                |                   |                   |                                 |
|----------------|-------------------|-------------------|---------------------------------|
| 1. PLUG        | 9. POPPET         | 17. WASHER        | 25. SPRING SEAT                 |
| 2. O-RING      | 10. CONTROL LEVER | 18. RETAINER      | 26. SNAP RING                   |
| 3. SPRING      | 11. COTTER PIN    | 19. SPOOL         | 27. SPRING CAP                  |
| 4. SHIM(S)     | 12. PIN           | 20. STEEL BALL    | 28. HOUSING                     |
| 5. PLUNGER     | 13. LINK          | 21. PLUNGER       | 29. PLUG (ONE SPOOL VALVE ONLY) |
| 6. SEAL        | 14. BRACKET       | 22. SPOOL SLEEVE  |                                 |
| 7. BODY        | 15. SCREW         | 23. QUAD RING     |                                 |
| 8. BACKUP RING | 16. WIPER         | 24. DETENT SLEEVE |                                 |

Figure 131 - Lift Section

21. Install the spring.

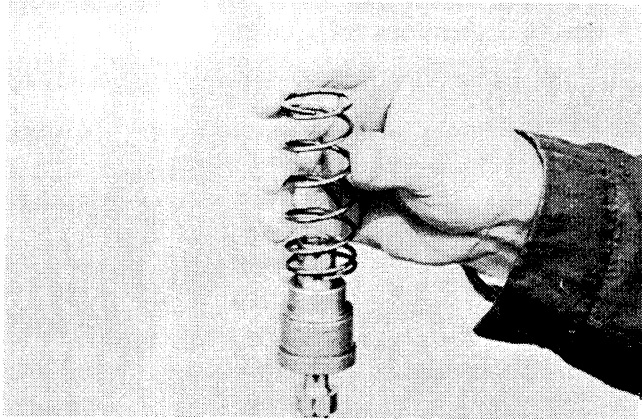

Figure 198

22. Install the spring seat.

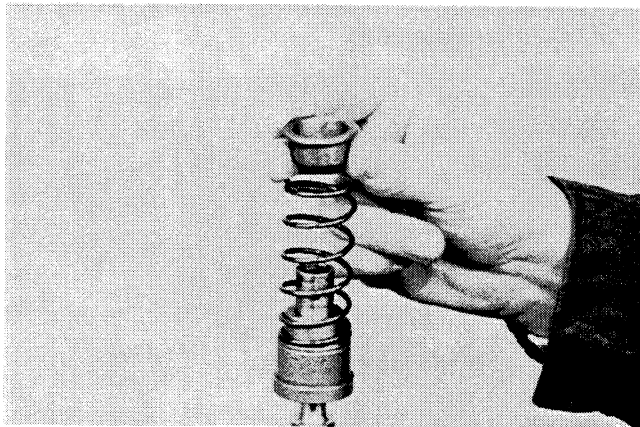

Figure 199

23. Install the top plate of the spring compressor tool and the nuts. Tighten the nuts to compress the spring until the snap ring can be installed on the spool.

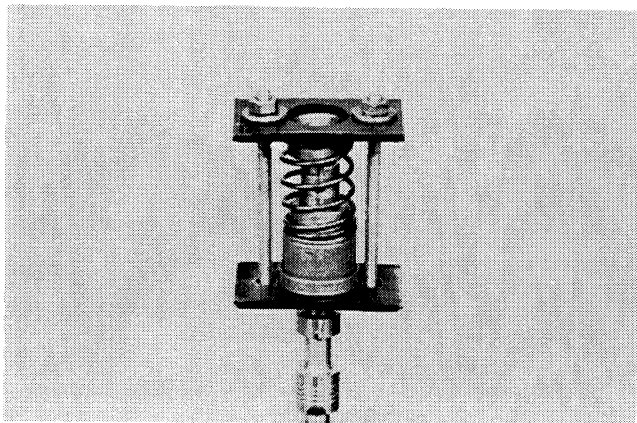

Figure 200

24. Install the snap ring.

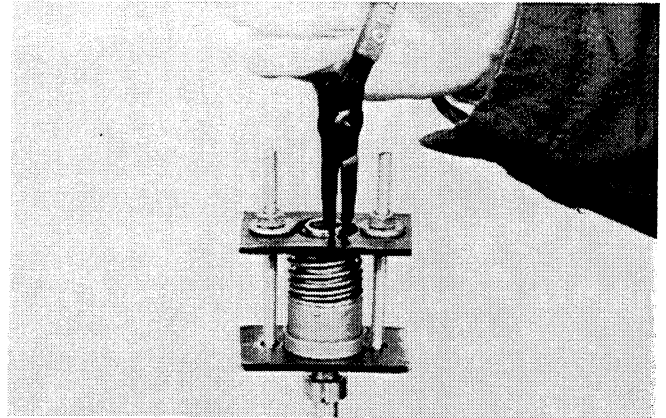
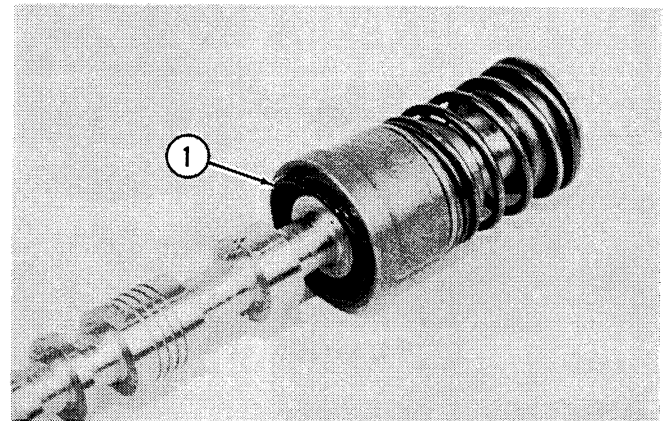

Figure 201

25. Remove the spool from the vise. Remove the spring compressor tool from the spool.

26. Install the O-ring in the groove in the detent sleeve.



1. O-ring

Figure 202

27. Install the spool sleeve on the spool.

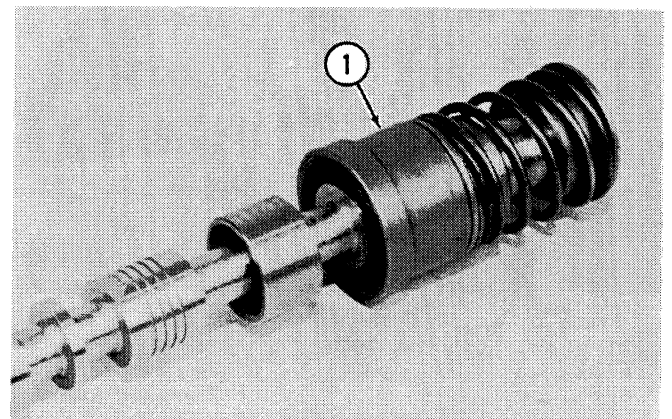

1. Spool Sleeve

Figure 203

6. Install the collar in the spring seat.

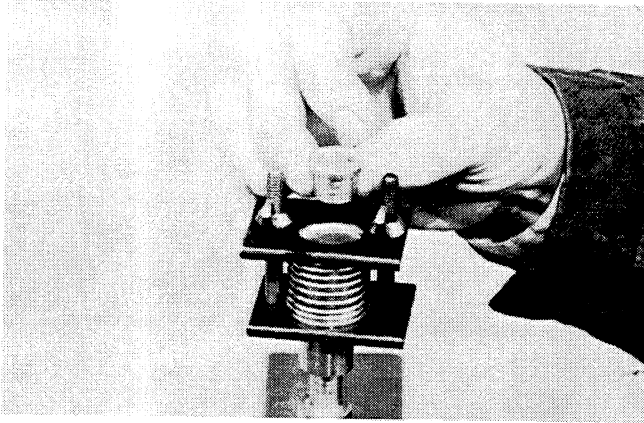
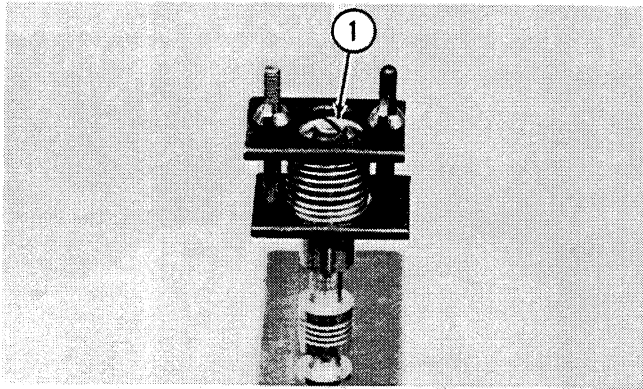

Figure 260

7. Install the lockwasher and screw.



1. Screw

Figure 261

8. Loosen the nuts on the spring compressor tool and remove the spring compressor tool from the spool. Remove the spool from the vise.

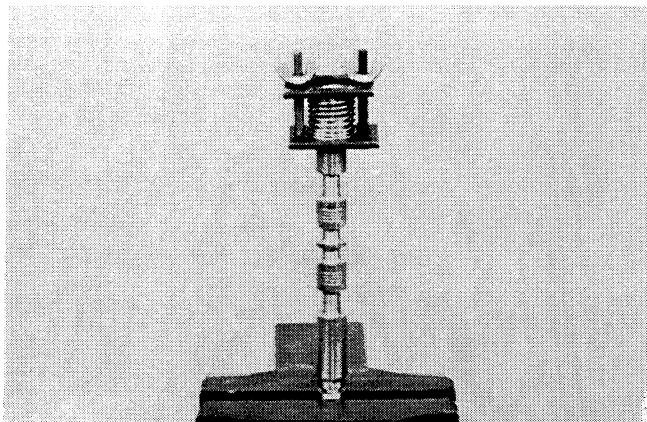
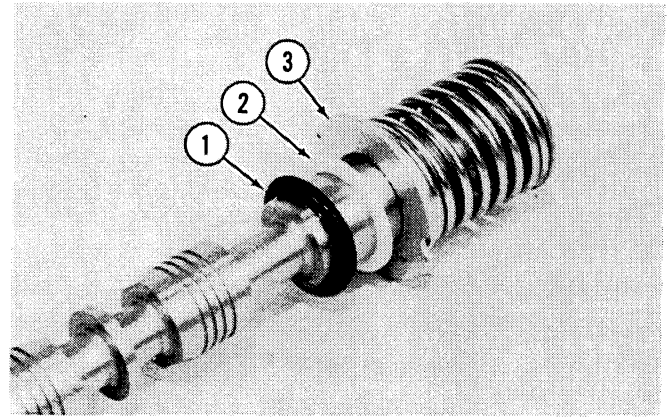

Figure 262

9. Install the washer, a new backup ring, and a new O-ring on the spool.



- 1. O-ring
- 2. Backup Ring
- 3. Washer

Figure 263

10. Put the section in the vise with the holes for the spring cap at the top.

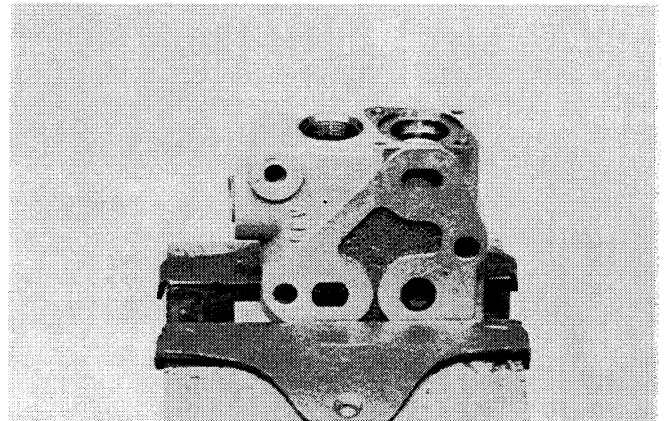

Figure 264

11. Install the poppet in the housing.

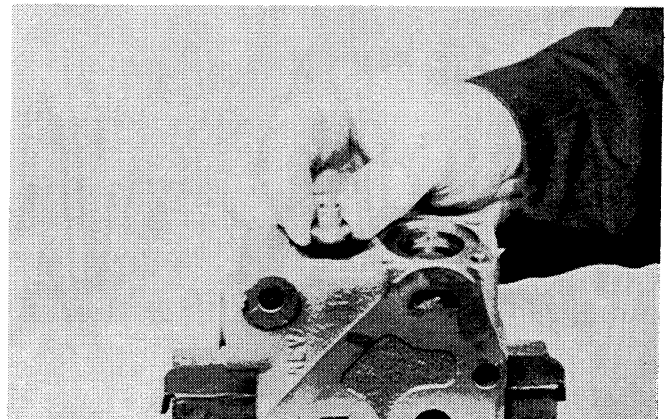

Figure 265

5. Disconnect the hoses for the extension cylinder at the tubes on the boom. Put identification tags on the hoses and tubes. Install caps and plugs on all hoses and fittings to prevent dirt entering the hydraulic system.
6. Remove one of the snap rings from the pivot pin at the closed end of the extension cylinder.
7. Remove the pivot pin.
8. Carefully remove the extension cylinder out of the dipper.

## Dipper Cylinder

1. Park the machine on a level surface.
2. Put the dipper in a position that will permit easy removal of the dipper cylinder.
3. Put supports under the dipper to keep the dipper in position when the hoses are disconnected from the dipper cylinder.
4. Apply the parking brake. Stop the engine.
5. Move the dipper control lever in both directions to remove pressure in the dipper hydraulic circuit.
6. Remove all dirt and grease from the hoses, tubes, and fittings.
7. Fasten a chain hoist to the dipper cylinder. Use the chain hoist to hold the weight of the dipper cylinder during removal of the pivot pins.
8. Remove one of the snap rings and washer from the pivot pin at the rod end of the dipper cylinder.
9. Remove the pivot pin. There are flat washers between the dipper and dipper cylinder rod eye. Be sure the flat washers are installed in the same location during assembly of the dipper cylinder to the dipper.
10. Remove the snap ring from the pivot pin at the closed end of the dipper cylinder.
11. Remove the pivot pin only as far as necessary to remove the dipper cylinder. There are flat washers between the dipper cylinder and the boom latch. Be sure the flat washers are installed in the same location during assembly of the dipper cylinder to the boom.
12. Carefully remove the dipper cylinder from the boom.

## Backhoe Bucket Cylinder

1. Park the machine on a level surface.
2. Extend the boom and dipper with the bucket in the dump position.
3. Put supports under the dipper to keep the dipper and bucket in position after the hoses are disconnected from the bucket cylinder.
4. Apply the parking brake. Stop the engine.
5. Move the bucket control lever in both directions to remove pressure in the bucket hydraulic circuit.
6. Remove all dirt and grease from the hoses, tubes, and fittings.
7. Disconnect the hoses for the bucket cylinder at the tubes on the dipper. Install caps and plugs on all hoses and fittings to prevent dirt entering the hydraulic system.
8. Fasten a chain hoist to the bucket cylinder. Use the chain hoist to hold the weight of the bucket cylinder during removal of the pivot pins.
9. Remove a snap ring and washer from the pivot pin at the rod end of the bucket cylinder.
10. Remove the pivot pin.
11. Remove a snap ring and washer from the pivot pin at the closed end of the bucket cylinder.
12. Remove the pivot pin.
13. Remove the bucket cylinder from the dipper.

## Stabilizer Cylinder

1. Park the machine on a level surface.
2. Lower the stabilizer to the floor.
3. Apply the parking brake. Stop the engine.
4. Move the stabilizer control lever in both directions to remove pressure in the stabilizer circuit.
5. Remove the dirt and grease from the hoses, tubes, and fittings.
6. Disconnect the hoses from the tubes at the closed end of the stabilizer cylinder.
7. Remove one of the snap rings from the pivot pin at the rod end of the stabilizer cylinder.

## BACKHOE SWING CYLINDER

### Disassembly

1. Put the cylinder in a vise. Tighten the vise carefully to prevent damage to the tube.
2. If equipped, remove the self-tapping screw from the gland and tube at the rod end of the cylinder.
3. Use the tool shown in Figure 1 to loosen the gland.

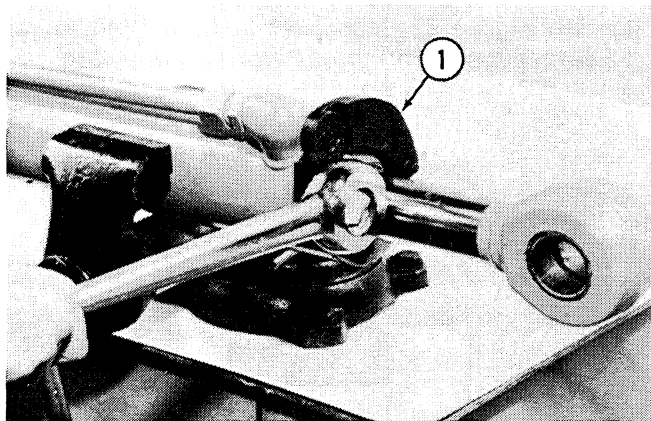

1. Gland Wrench  
Figure 19

4. Remove the gland from the cylinder.
5. Pull the rod straight out of the tube to prevent damage to the tube.
6. Remove the tube from the vise.
7. Put the rod eye in the vise and a support under the rod. Put the support stand close to the piston. Use a shop cloth between the support stand and rod to prevent damage to the rod.

8. Remove the cap screw and hardened washer that hold the piston on the rod. The torque of the cap screw is 475 - 525 pound-feet (644 - 712 N m). A torque multiplier can be used to loosen the cap screw.

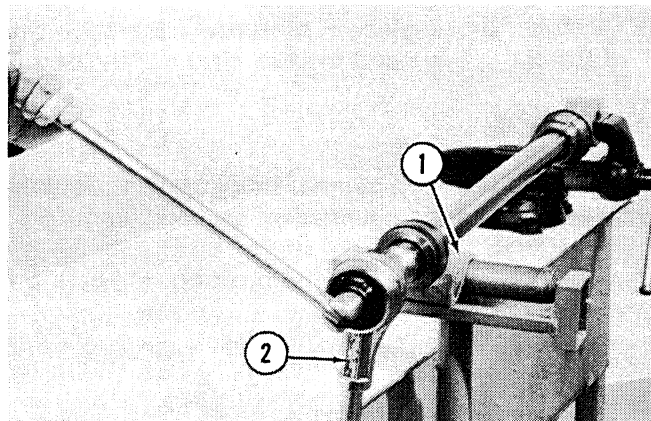

1. Shop Cloth  
2. Torque Multiplier  
Figure 20

9. Remove the pin, spring, and steel ball from the end of the rod.
10. Remove the piston from the rod.
11. Remove the wear rings, seal, and backup ring from the piston.
12. Use a soft hammer to remove the gland from the rod.
13. Remove the wiper, seals, bushing, O-ring, and backup ring from the gland.

**NOTE:** Remove the nylon plug only if the gland has been removed from the tube five times.

### Inspection

1. Discard the wear rings, backup ring, and seal from the piston.
2. Discard the wiper, seals, bushing, and O-ring from the gland.
3. Clean all parts in cleaning solvent. All parts must be dry before assembly.
4. Put light into the tube. Inspect the inside of the tube for deep grooves or other damage. If there is damage to the tube, the tube must be replaced.

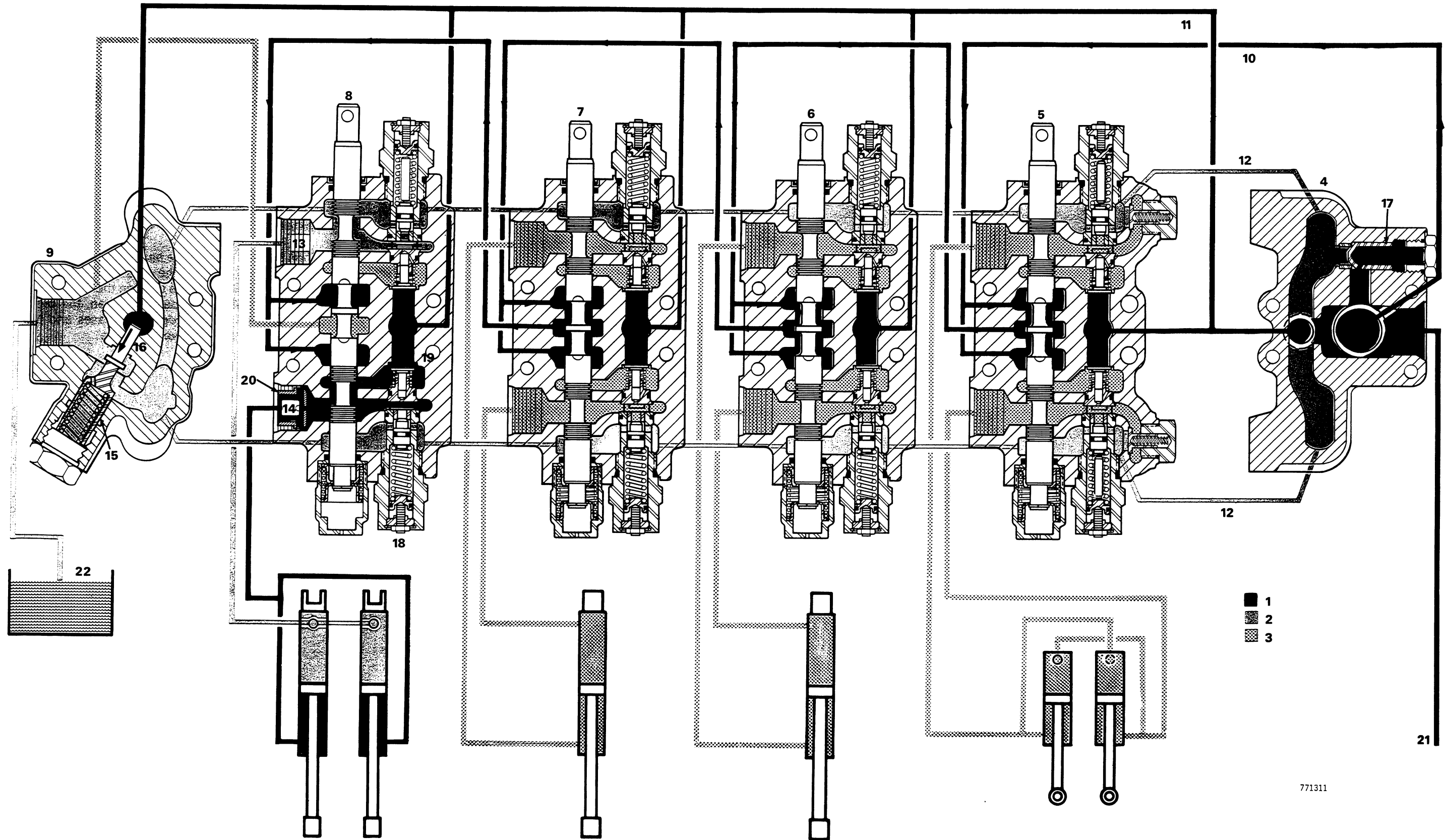

1. PUMP FLOW  
2. RETURN OIL  
3. STATIC OIL

4. INLET  
5. SWING  
6. BUCKET  
7. DIPPER

8. BOOM  
9. OUTLET  
10. OPEN CENTER PASSAGE (INTERNAL)  
11. PARALLEL PASSAGE (INTERNAL)

12. RETURN PASSAGE  
13. A PORT  
14. B PORT  
15. REGENERATION SPOOL

16. REGENERATION PISTON  
17. REGENERATION CHECK VALVE  
18. SECONDARY RELIEF VALVE  
19. LOAD CHECK VALVE

20. BOOM DOWN RESTRICTOR  
21. FROM THE HYDRAULIC PUMP THROUGH THE  
LOADER OR DOZER CONTROL VALVE AND  
STABILIZER CONTROL VALVE  
22. HYDRAULIC OIL RESERVOIR

Figure 5 - Boom Spool Actuated

10. Install the swing section.

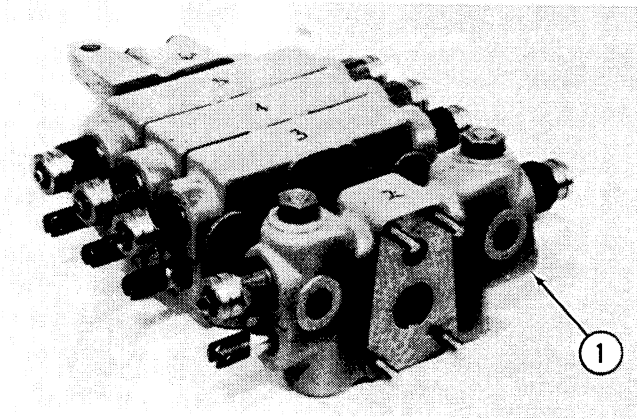

1. Swing Section  
Figure 24

13. Install the nuts on the studs, Figure 26. Tighten the nuts evenly to 20 - 30 pound-feet (27 - 41 N m).

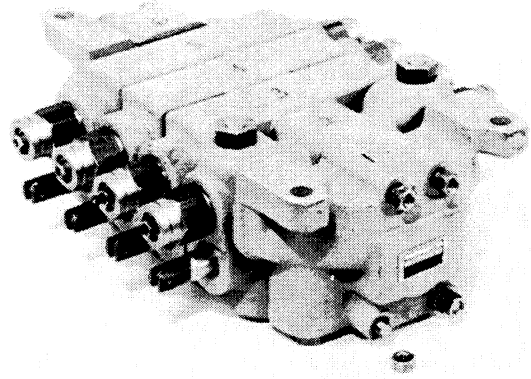
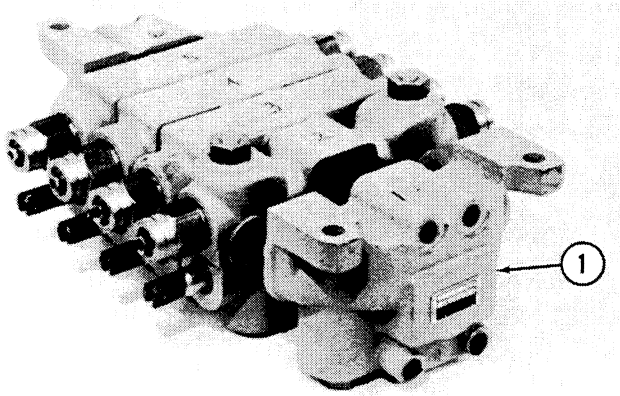

Figure 26

11. Put the shims on the studs. Push the shims against the swing section.

12. Install the inlet section.



1. Inlet Section  
Figure 25

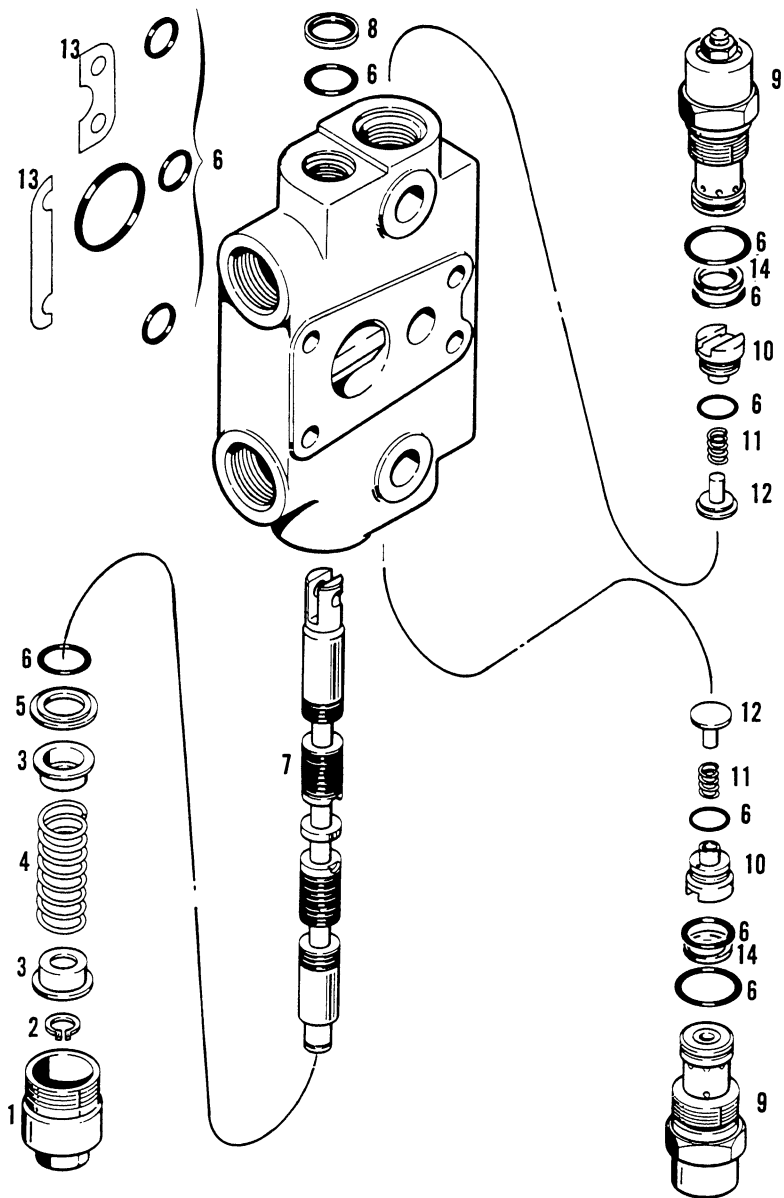

751597A

- |                     |                           |                       |
|---------------------|---------------------------|-----------------------|
| 1. SPRING CAP       | 6. O-RING                 | 11. SPRING            |
| 2. SNAP RING        | 7. SPOOL                  | 12. LOAD CHECK POPPET |
| 3. SPRING GUIDE     | 8. WIPER                  | 13. SHIM              |
| 4. CENTERING SPRING | 9. SECONDARY RELIEF VALVE | 14. BACKUP RING       |
| 5. RETAINER         | 10. PLUG                  |                       |

Figure 76 - Dipper, Bucket, and Boom Section

## SPECIFICATIONS

### Ports and Spools

Spool movement, neutral to pressure .....	5/16 inch (7.9 mm) in and out
Spool moved in .....	pressure at A port
Spool moved out .....	pressure at B port
Inlet and power beyond port .....	1-1/16-12 straight thread
Outlet, A ports and B ports .....	7/8-14 straight thread

### Springs

	Free Length	Compressed length
Centering .....	.9375 inch (23.81 mm)	.6875 inch at 26.1-31.9 pounds (17.46 mm at 11.8-14.4 kg)
Check valve .....	1.083 mm 27.51 mm)	.75 inch at .4-.6 pounds (19.0 mm at .18-.27 kg)

### Special Torques

Spring cap .....	35-40 pound-feet (47-54 N m)
Plug .....	35-40 pound-feet (47-54 N m)

## SPECIAL TOOLS

See Figure 1 and make two plates to compress the centering springs when a centering spring is removed or installed.

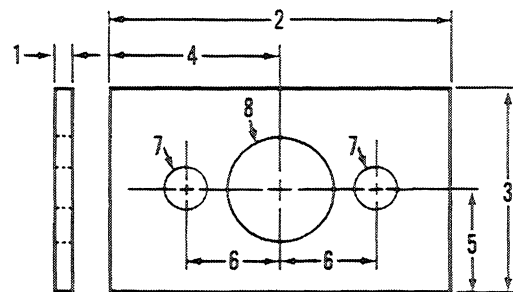

- |                           |                         |
|---------------------------|-------------------------|
| 1. 1/8 INCH (3.2 mm)      | 7. 5/16 INCH (7.9 mm)   |
| 2. 2-1/2 INCHES (63.5 mm) | 8. 13/16 INCH (20.6 mm) |
| 3. 1-1/2 INCHES (38.1 mm) | TOP PLATE               |
| 4. 1-1/4 INCHES (31.8 mm) | 11/16 INCH (17.5 mm)    |
| 5. 3/4 INCH (19 mm)       | BOTTOM PLATE            |
| 6. 11/16 INCH (17.5 mm)   | 751567                  |

Figure 1

# Section 8121

## BOOM LOCK SYSTEM

Written In *Clear  
And  
Simple  
English*

# Section 9010

## LOADER

Written In *Clear  
And  
Simple  
English*

11. Loosen and remove the cap and plug from the other hose and tube.

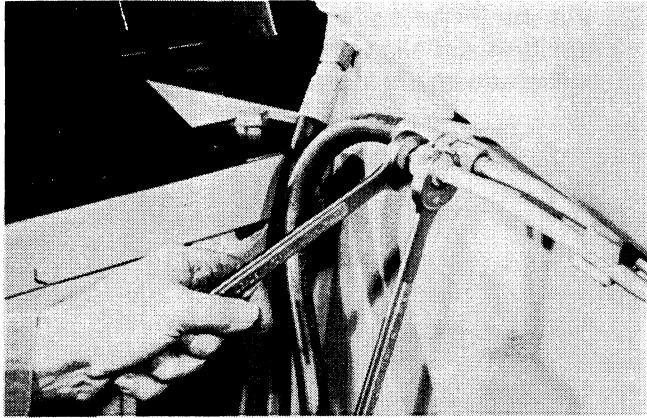

Figure 41

12. Connect the other hose to the tube.

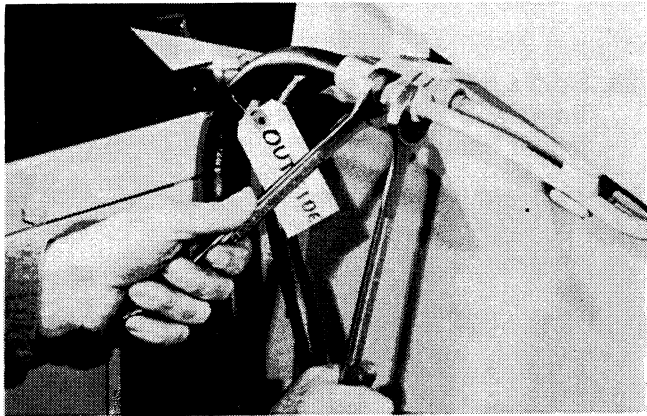

Figure 42

13. Put the lift or loader control lever in the Float position and align the piston rod eye of the right lift cylinder.

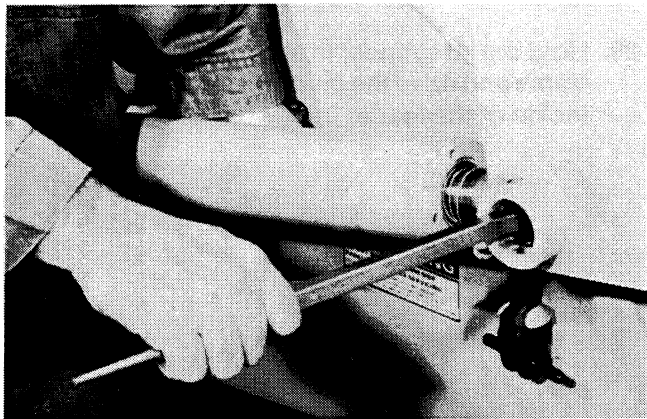

Figure 43

14. Start the pivot pin into the loader frame. If the machine is equipped with antirollback mechanism, hold the front bellcrank in alignment with the loader frame and start the pivot pin into the loader frame.

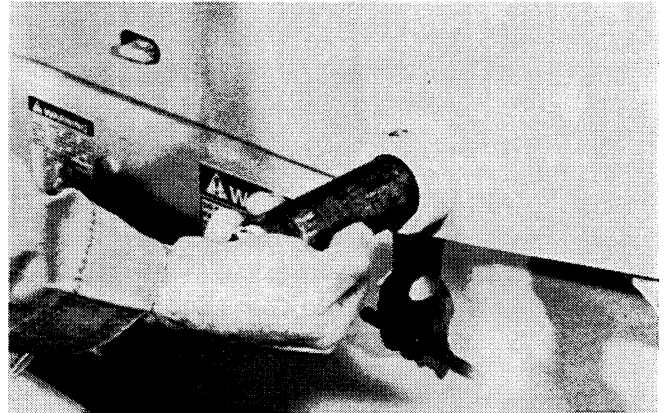

Figure 44

15. Hold the lift cylinder in place and drive the pivot pin all the way into the loader frame. Be sure that the bolt holes in the pivot pin and loader frame are aligned.

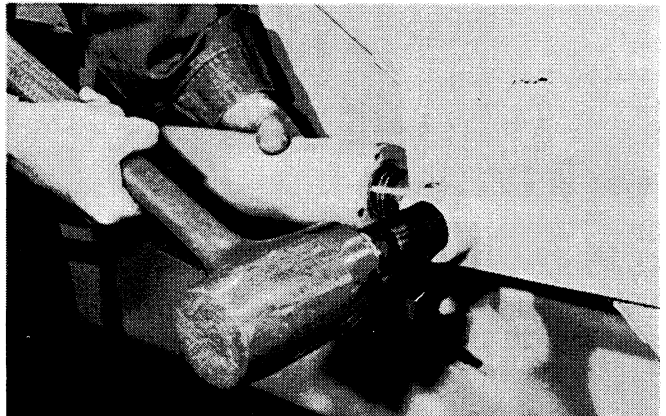

Figure 45

16. Install the bolt that holds the pivot pin in place.

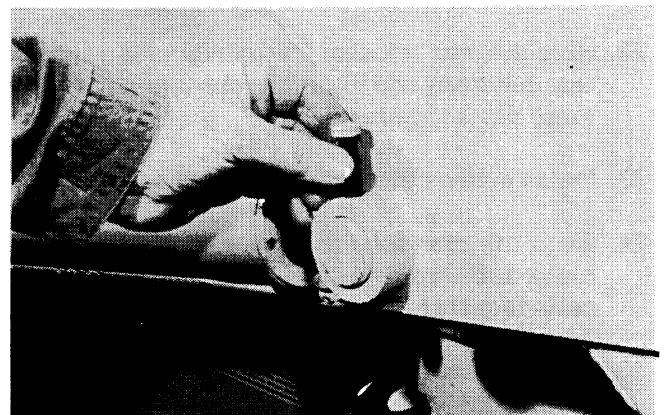
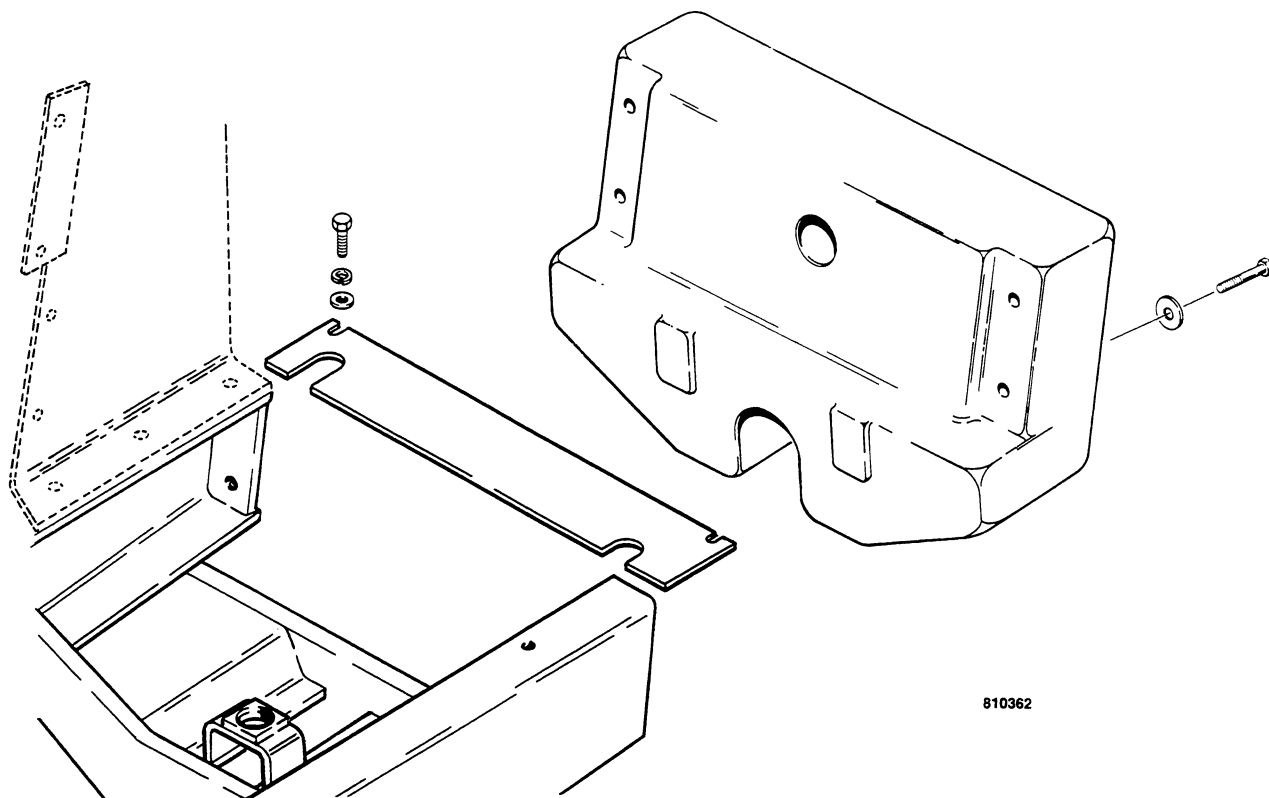
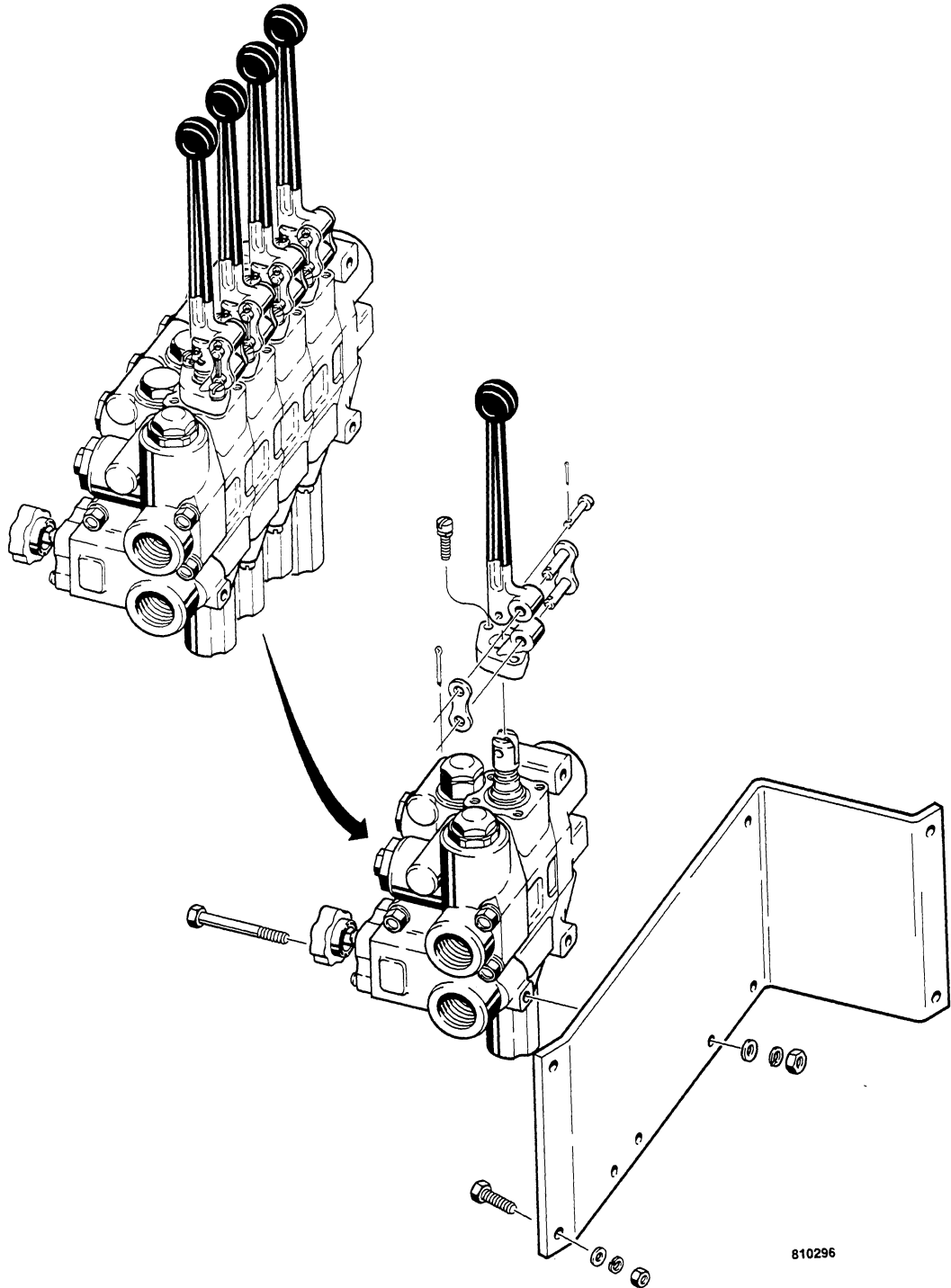

Figure 46



**NOTE:** THE WEIGHT OF THE FRONT COUNTERWEIGHT IS APPROXIMATELY 700 POUNDS (317 kg). USE ACCEPTABLE LIFTING EQUIPMENT TO REMOVE AND INSTALL THE FRONT COUNTERWEIGHT.

Figure 68 - Front Counterweight



810296

Figure 8 - Control Levers

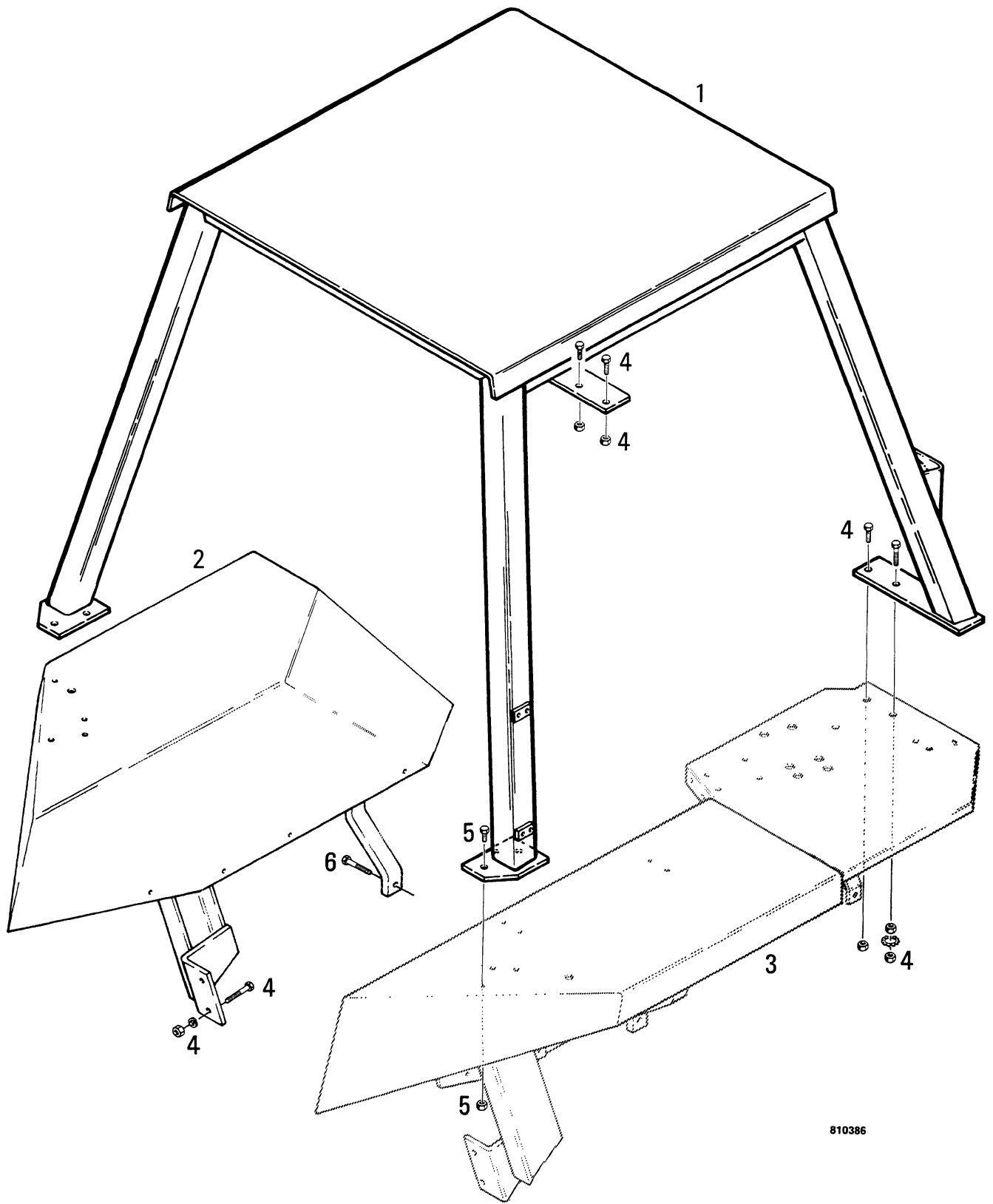

1. ROPS CANOPY  
2. LEFT FENDER

3. RIGHT FENDER  
4. TIGHTEN TO 200 - 240 POUND-FEET  
(271 - 325 N m) GRADE 8 HARDWARE

5. TIGHTEN TO 100 - 120 POUND-FEET  
(136 - 162 N m) GRADE 8 HARDWARE  
6. TIGHTEN TO 65 - 85 POUND-FEET  
(88 - 115 N m)

Figure 32 - ROPS Canopy for 480D

## BACKHOE REMOVAL

1. Park the machine on level surface and lower the loader bucket to the floor.
2. Put the operators seat in position to operate the backhoe.
3. Put the backhoe in the position shown in Figure 1.

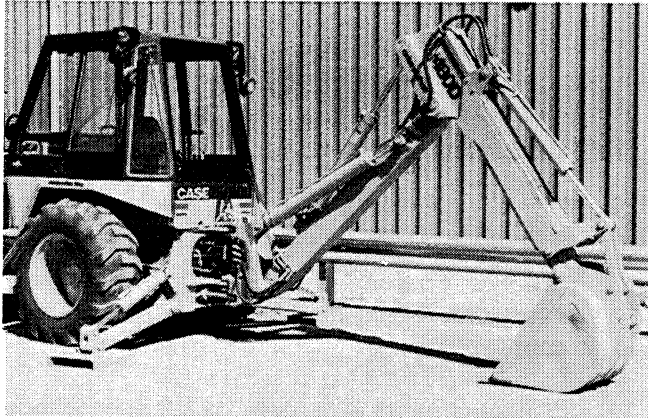
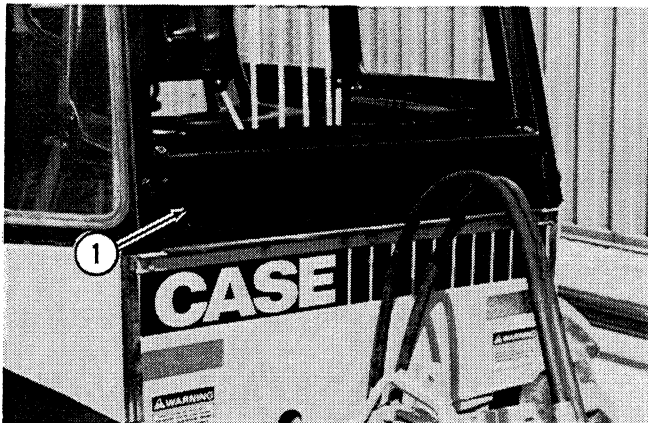

Figure 1

4. Stop the engine.
5. If the machine has a ROPS canopy, go to step 7.
6. If the machine has a ROPS cab:
  - a. Disconnect the wiring from the rear windshield wiper.
  - b. Raise the rear window.
  - c. Removal the panel at the bottom of the rear window opening.



1. Panel

Figure 2

7. Loosen and remove the four wing nuts that fasten the mounting frame to the machine.

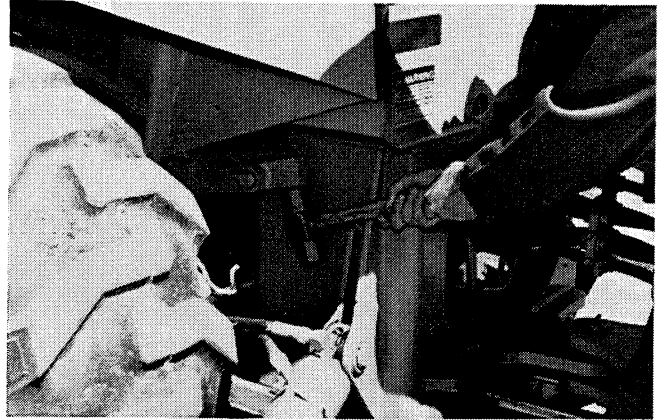

Figure 3

8. Use the boom and stabilizers as required to remove the weight of the backhoe from the bolts that hold the mounting frame in place. Then remove the four bolts.
9. Move the machine forward far enough so that the mounting frame can be lowered to the floor and the hoses disconnected.

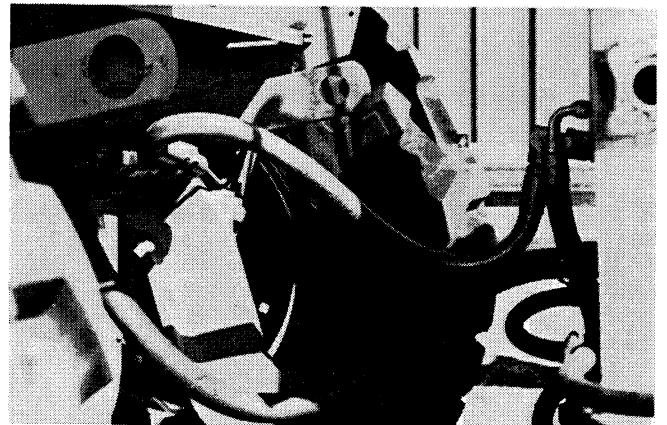

Figure 4

- d. Remove the panel that is between the fenders.

57. Operate the hydraulic ram to push the pivot pin out of the swing tower.

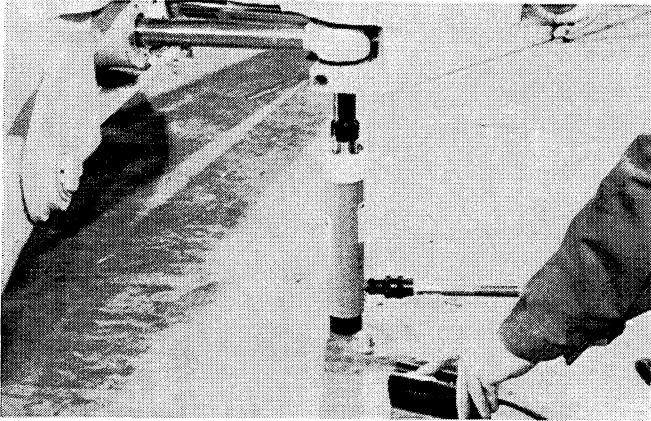

Figure 63

58. If the pivot stops moving, hit the swing tower with a hammer to loosen the pivot pin. Use the hydraulic ram and hammer as required until the pivot pin is free of the swing tower.

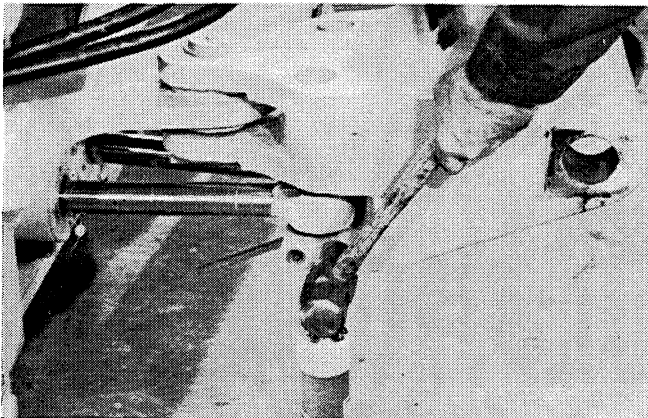

Figure 64

59. Remove the pivot pin.

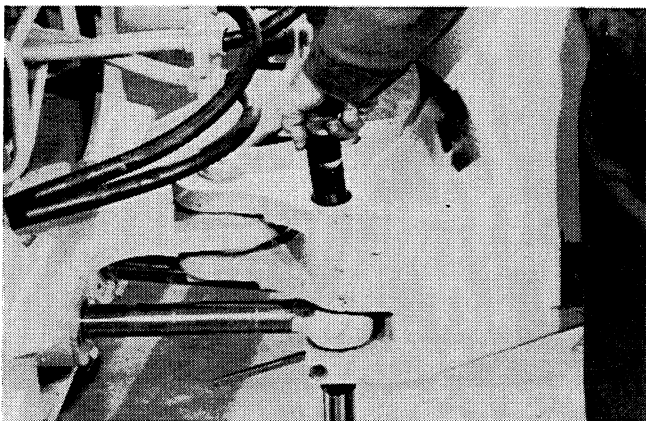

Figure 65

60. Turn the piston rod eyes of the swing cylinders as shown in Figure 66 so that the bottom pivot pin can be removed.

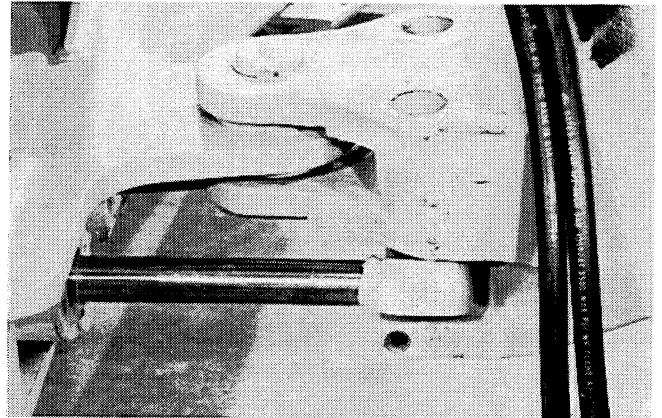

Figure 66

61. Remove the snap ring from the bottom pivot pin.

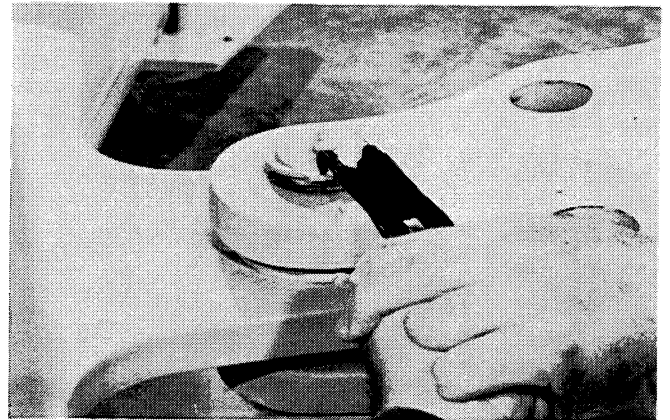

Figure 67

62. Loosen and remove the grease fitting from the bottom pivot pin.

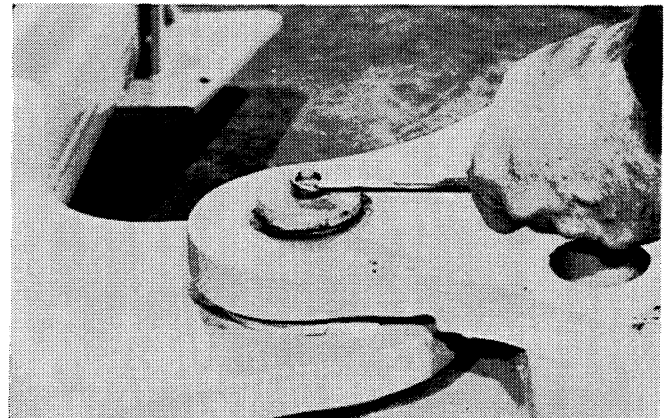

Figure 68

60. Connect the hose to the elbow. Be sure the hose does not turn when the connection is tightened.

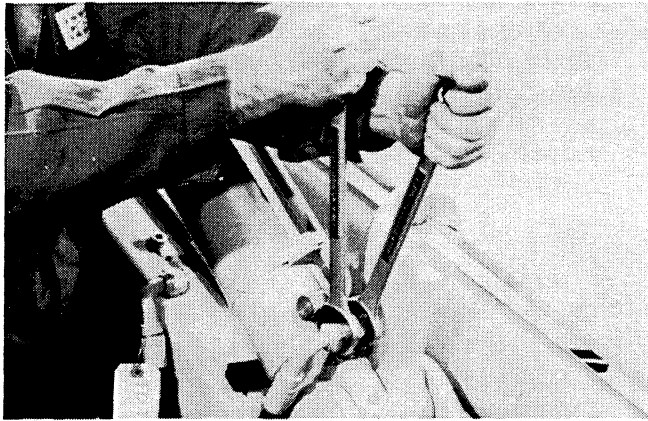

Figure 134

63. Lubricate the bottom and top pivot pins for the swing tower.

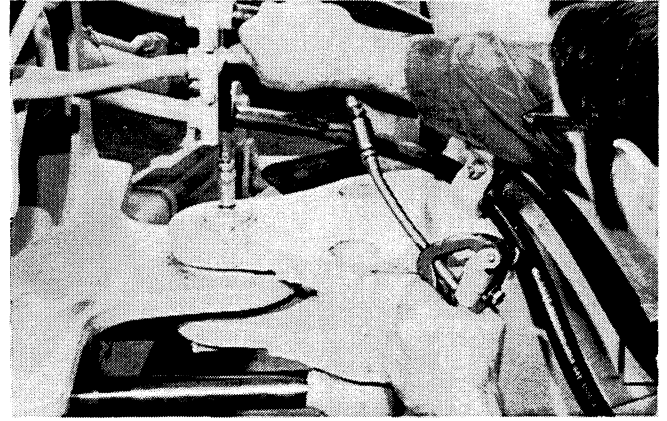

Figure 137

61. Loosen and remove the cap from the tube on the dipper cylinder and the plug from the hose with the identification tag.

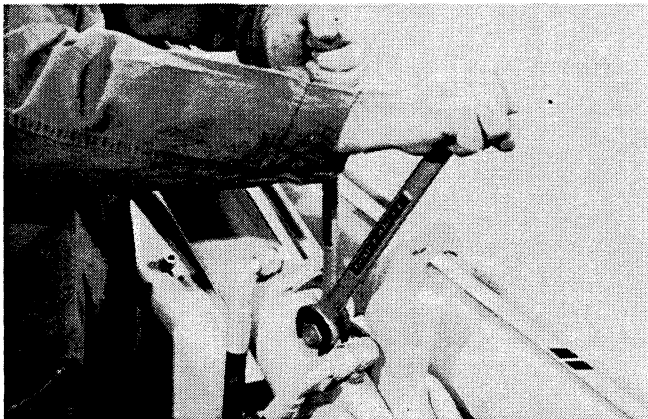

Figure 135

64. Lubricate the piston rod eyes for the swing cylinders.

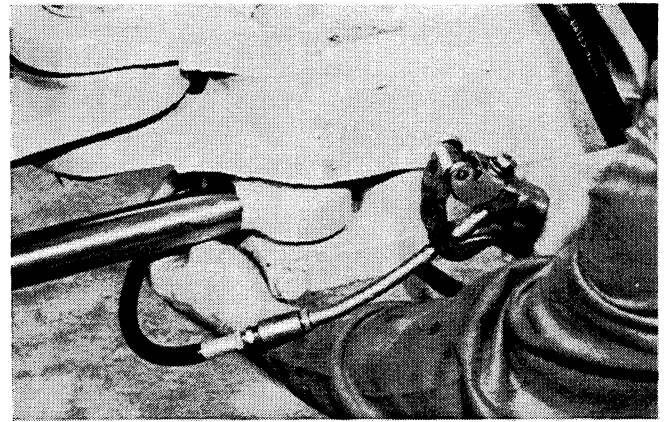

Figure 138

62. Connect the hose to the tube. Be sure the hose does not turn when the connection is tightened.

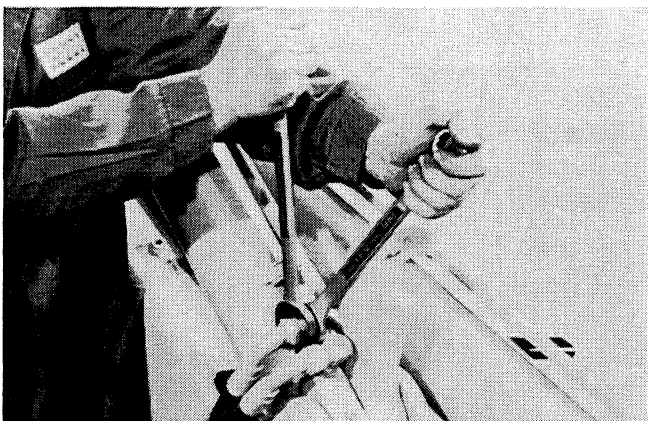

Figure 136

65. Lubricate the pivot pin for the boom cylinder.

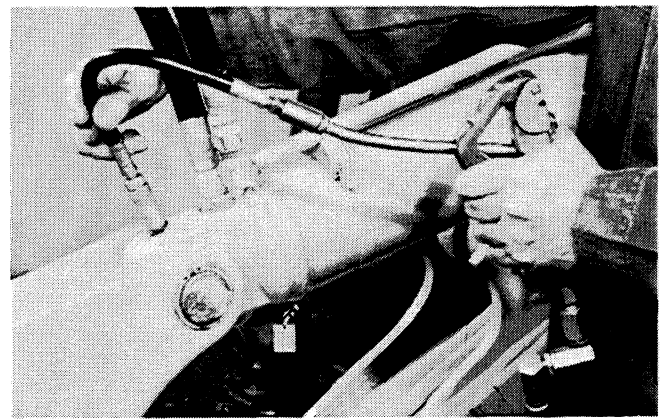

Figure 139

9. Drive the pivot pin into the dipper extension.

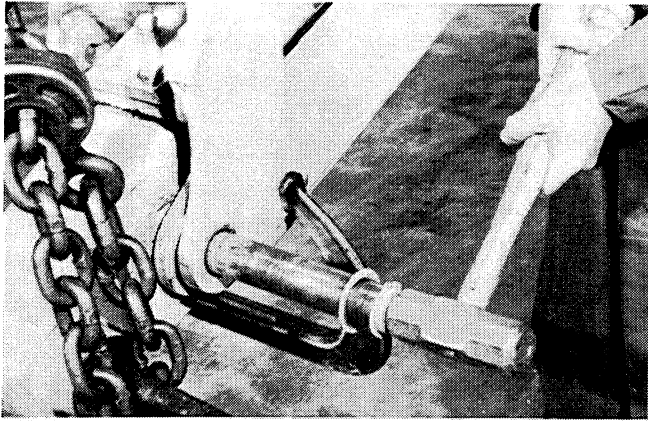

Figure 171

12. Hold the guide link in alignment with the pivot pin and drive the pivot pin all the way into the dipper extension.

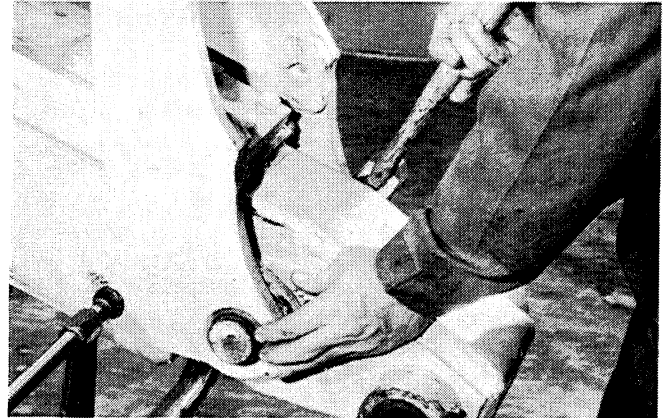

Figure 174

10. Remove the lifting sling.

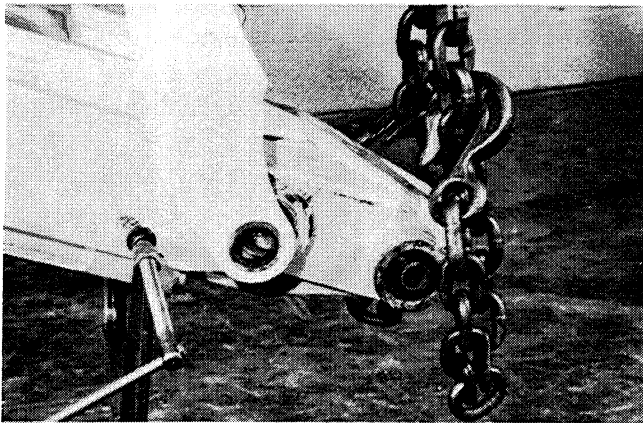

Figure 172

13. Remove the C-clamp and spacers.

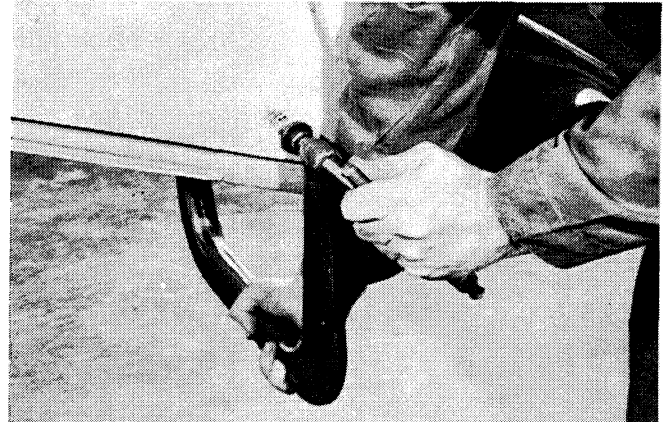

Figure 175

11. If used, put a flat washer in place between the guide link and sliding collar. Use grease to hold the flat washer in place.

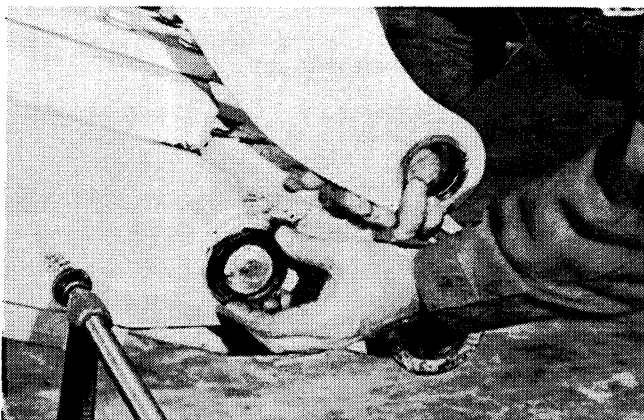

Figure 173

14. Put the flat washer on the pivot pin.

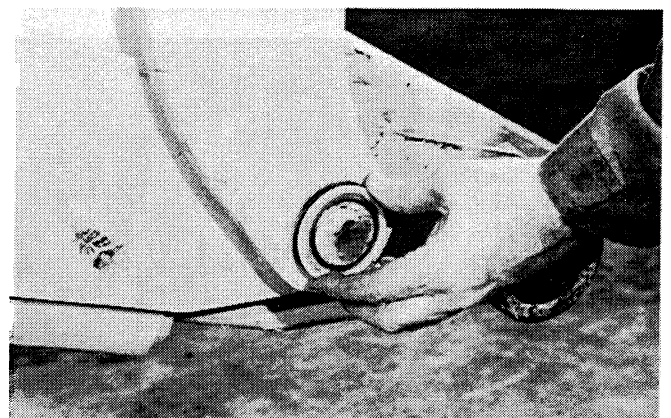
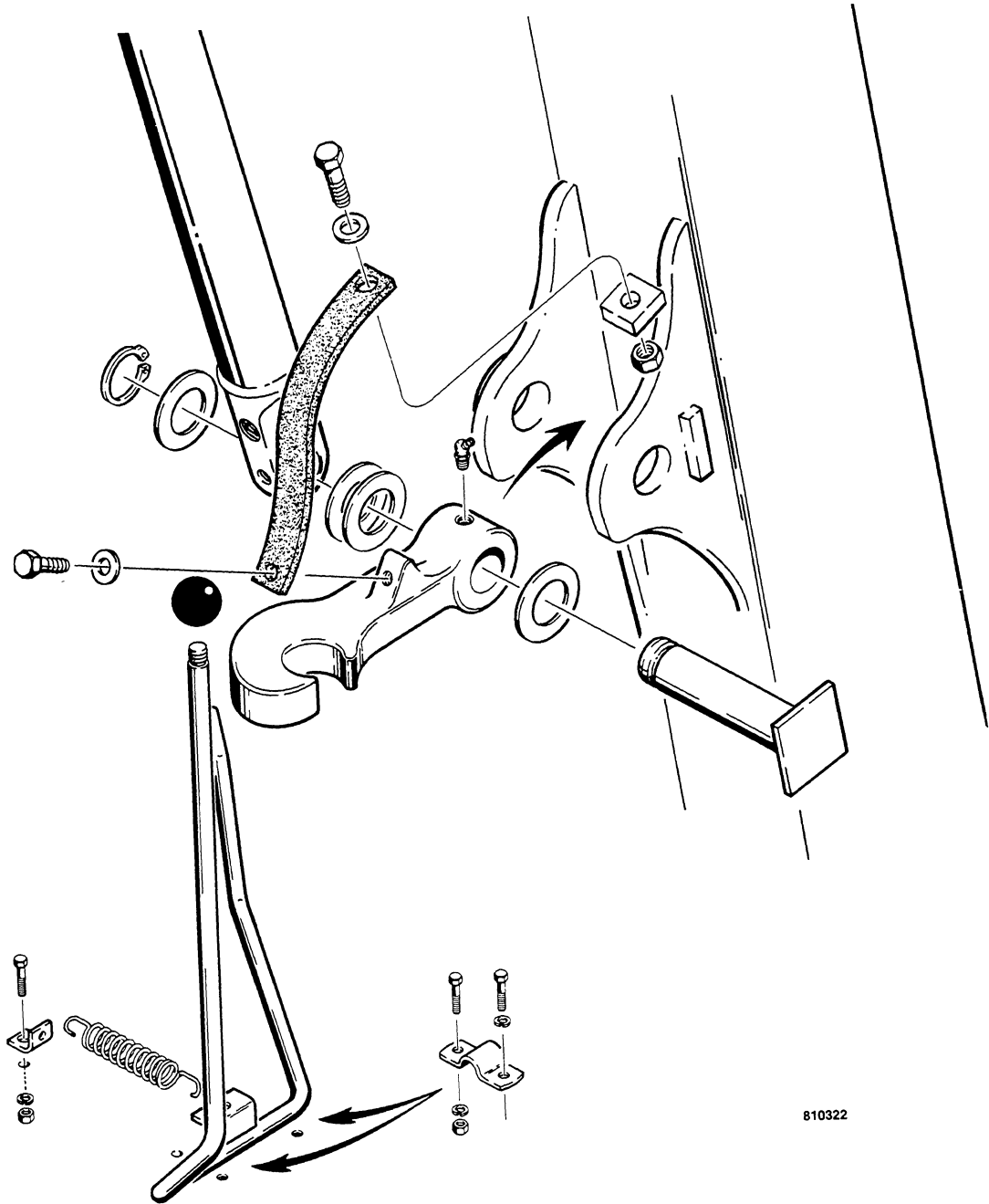
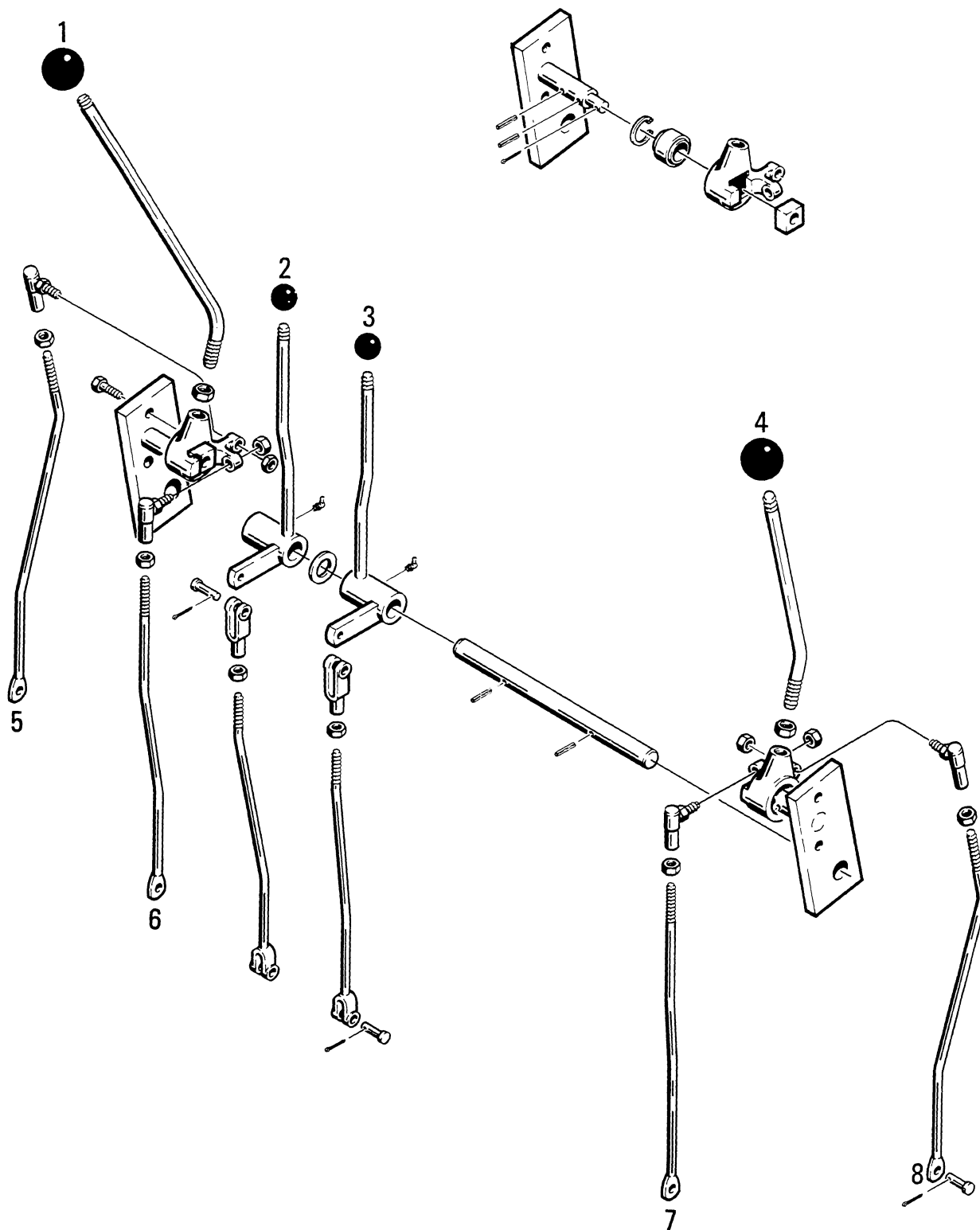

Figure 176



810322

Figure 202 - Transport Lock Mechanism



1. BOOM AND SWING  
2. LEFT STABILIZER

3. RIGHT STABILIZER  
4. BUCKET AND DIPPER

5. BOOM  
6. SWING

7. BUCKET  
8. DIPPER

810334

Figure 214 - Backhoe Controls With Hand Swing

CLICK HERE TO **DOWNLOAD** THE COMPLETE MANUAL

- Thank you very much for reading the preview of the manual.
- You can download the complete manual from: [www.heydownloads.com](http://www.heydownloads.com) by clicking the link below



- Please note: If there is no response to CLICKING the link, please download this PDF first and then click on it.

CLICK HERE TO **DOWNLOAD** THE COMPLETE MANUAL