

CASE

PROFESSIONAL PARTNER

SERVICE MANUAL
SKID STEER
COMPACT TRACK LOADER

410
420
420CT

87364090 NA
Replaces 6-78950 NA

Revised 03-2006
Issued 02-2005

CLICK HERE TO **DOWNLOAD** THE COMPLETE MANUAL

- Thank you very much for reading the preview of the manual.
- You can download the complete manual from: www.heydownloads.com by clicking the link below



- Please note: If there is no response to CLICKING the link, please download this PDF first and then click on it.

CLICK HERE TO **DOWNLOAD** THE COMPLETE MANUAL

Section 1001

FLUIDS AND LUBRICANTS

TORQUE SPECIFICATIONS - STEEL HYDRAULIC FITTINGS

37 Degree Flare Fitting				
Nom. SAE Dash Size	Tube OD/Hose ID	Thread Size	Newton metres	Pound-Inches
-2		5/16 - 24	8 to 9	72 to 84
-3		3/8 - 24	11 to 12	96 to 108
-4	6.4 mm (1/4 inch)	7/16 - 20	14 to 16	120 to 144
-5	7.9 mm (5/16 inch)	1/2 - 20	18 to 21	156 to 192
-6	9.5 mm (3/8 inch)	9/16 - 18	27 to 33	240 to 300
-8	12.7 mm (1/2 inch)	3/4 - 16	46 to 56	408 to 504
-10	15.9 mm (5/8 inch)	7/8 - 14	77 to 85	684 to 756
				Pound-Feet
-12	19.0 mm (3/4 inch)	1-1/16 - 12	107 to 119	79 to 88
-14	22.2 mm (7/8 inch)	1-3/16 - 12	127 to 140	94 to 103
-16	25.4 mm (1.0 inch)	1-5/16 - 12	131 to 156	97 to 117
-20	31.8 mm (1-1/4 inch)	1-5/8 - 12	197 to 223	145 to 165
-24	38.1 mm (1-1/2 inch)	1-7/8 - 12	312 to 338	230 to 250

Straight Threads with O-ring				
Nom. SAE Dash Size	Tube OD/Hose ID	Thread Size	Newton metres	Pound-Inches
-2		5/16 - 24	8 to 9	72 to 84
-3		3/8 - 24	11 to 12	96 to 108
-4	6.4 mm (1/4 inch)	7/16-20	20 to 25	180 to 228
-5	7.9 mm (5/16 inch)	1/2-20	27 to 33	240 to 300
-6	9.5 mm (3/8 inch)	9/16-18	43 to 54	384 to 480
-8	12.7 mm (1/2 inch)	3/4-16	73 to 90	648 to 804
				Pound-Feet
-10	15.9 mm (5/8 inch)	7/8-14	100 to 124	74 to 92
-12	19.0 mm (3/4 inch)	1-1/16-12	138 to 173	102 to 128
-14	22.2 mm (7/8 inch)	1-3/16-12	173 to 216	128 to 160
-16	25.4 mm (1.0 inch)	1-5/16-12	203 to 253	150 to 187
-20	31.8 mm (1-1/4 inch)	1-5/8-12	308 to 357	227 to 264
-24	38.1 mm (1-1/2 inch)	1-7/8-12	492 to 542	363 to 400

SECTION INDEX

ENGINE

Section Title	Section Number
Engine and Radiator Removal and Installation	2000
For Engine Repair, see the Engine Service Manual	

STEP 8



1. CYLINDER PIVOT BOLT

BD05A029

Remove the nut from cylinder pivot bolt (1) on the hood end of the cylinder.

STEP 9

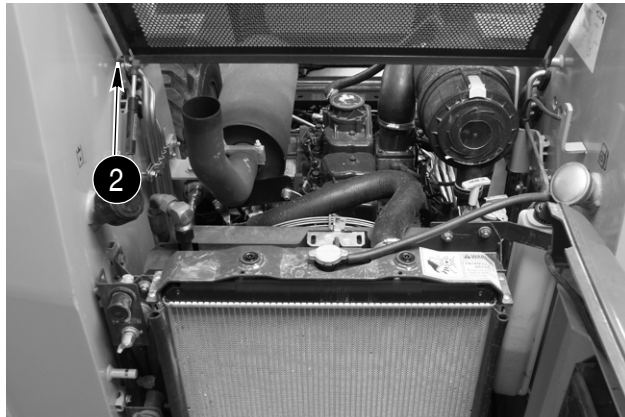

BD05A066

Remove the plastic clip (2) from the hood pivot shaft. Slide the hood to the left and remove the hood from the hood pivot shaft on both sides of the machine. Remove the hood from the machine.

STEP 10

Push the hood to the right hand side of the machine and remove the left hand side of the hood from the pivot pin. Remove the hood from the machine.

STEP 11



1. AIR RESTRICTION INDICATOR SWITCH

BD05B050

Disconnect the electrical connector for the air restriction indicator switch (1).

STEP 12

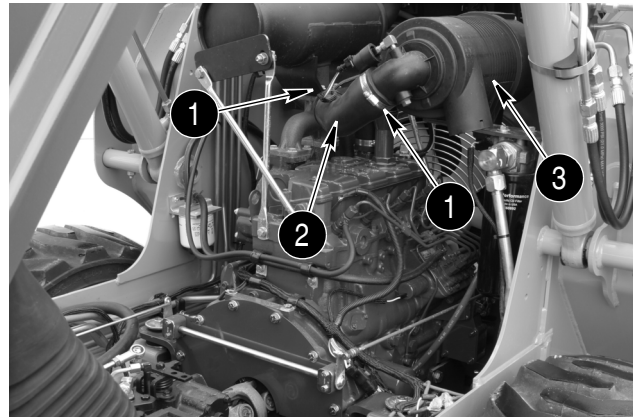

BD05B049

Loosen the clamps (1) on the outlet hose (2). Remove the outlet hose (2) from the intake and air filter assembly (3).

NOTE: Torque clamps (1) 3 to 4 Nm (25 to 35 pound-inches) during assembly.

NOTE: Refer to illustration on page 14 and 15.

STEP 13

Loosen and remove the mounting bolts and washers from the air filter housing mounting bracket.

STEP 14

Remove the air cleaner and bracket from the machine.

**Insert
Tab 3**

Connector 58	65
Connector 59	65
Connector 79	65
Connector 80	66
Connector 103	66
Connector 127	66
Connector 127A	66
CONNECTORS	
SCHEMATIC FRAME 6	67
Connector 8	67
Connector 8A	67
Connector 23 Instrument Cluster	68
Connector 29	68
Connector 30	68
Connector 52	69
Connector 52A	69
CONNECTORS	
SCHEMATIC FRAME 7	70
Connector 8	70
Connector 8A	70
Connector 32	70
Connector 33	70
Connector 34	71
Connector 93	71
Connector 96	71
Connector 99	72
CONNECTORS	
SCHEMATIC FRAME 8	72
Connector 39 (Grey)	72
CONNECTORS	
SCHEMATIC FRAME 10	72
Connector 50A	72
Connector 51	72
Connector 51A	73
Connector 65	73
Connector 65A	73
Connector 112	73
Connector 113	74
Connector 140	74
Connector 140A	74
Connector 141 Wiper/Washer Switch	74
CONNECTORS	
SCHEMATIC FRAME 11	75
Connector 70	75
Connector 70A	75
Connector 72	75
Connector 81	75
Connector 81B	76
Connector 120	76
Connector 121	76
Connector 122	76
Connector 123	77
Connector 124	77
CONNECTORS	
SCHEMATIC FRAME 12	77
Connector 77	77
CONNECTORS	

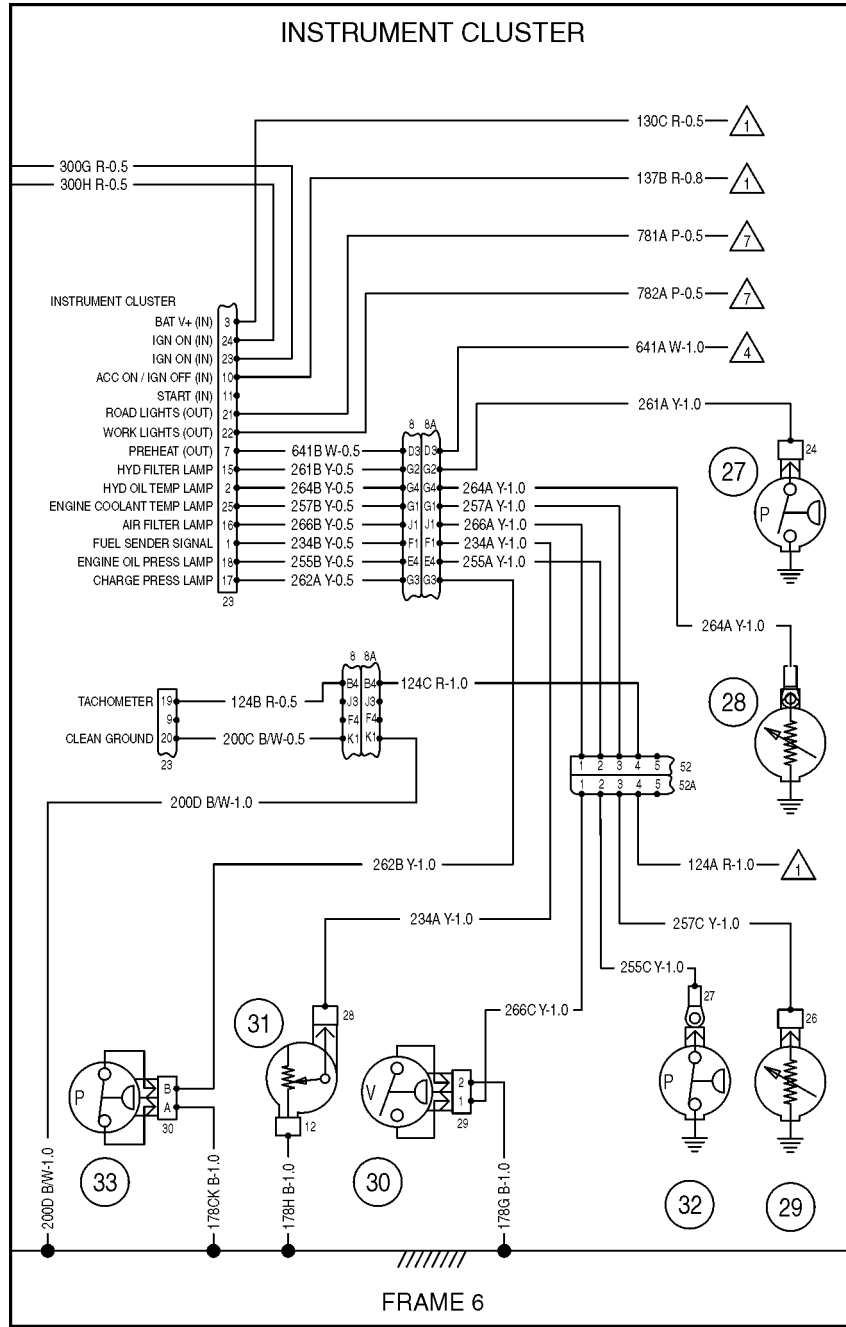

BC04M092-06

- 26. NOT USED
- 27. HYDRAULIC FILTER PRESSURE SWITCH
- 28. HYDRAULIC OIL TEMPERATURE SENDER
- 29. ENGINE COOLANT TEMPERATURE SENDER
- 30. AIR FILTER RESTRICTION SWITCH
- 31. FUEL SENDER
- 32. ENGINE OIL PRESSURE SWITCH
- 33. CHARGE PRESSURE SWITCH

ELECTRICAL SCHEMATIC FRAME 6

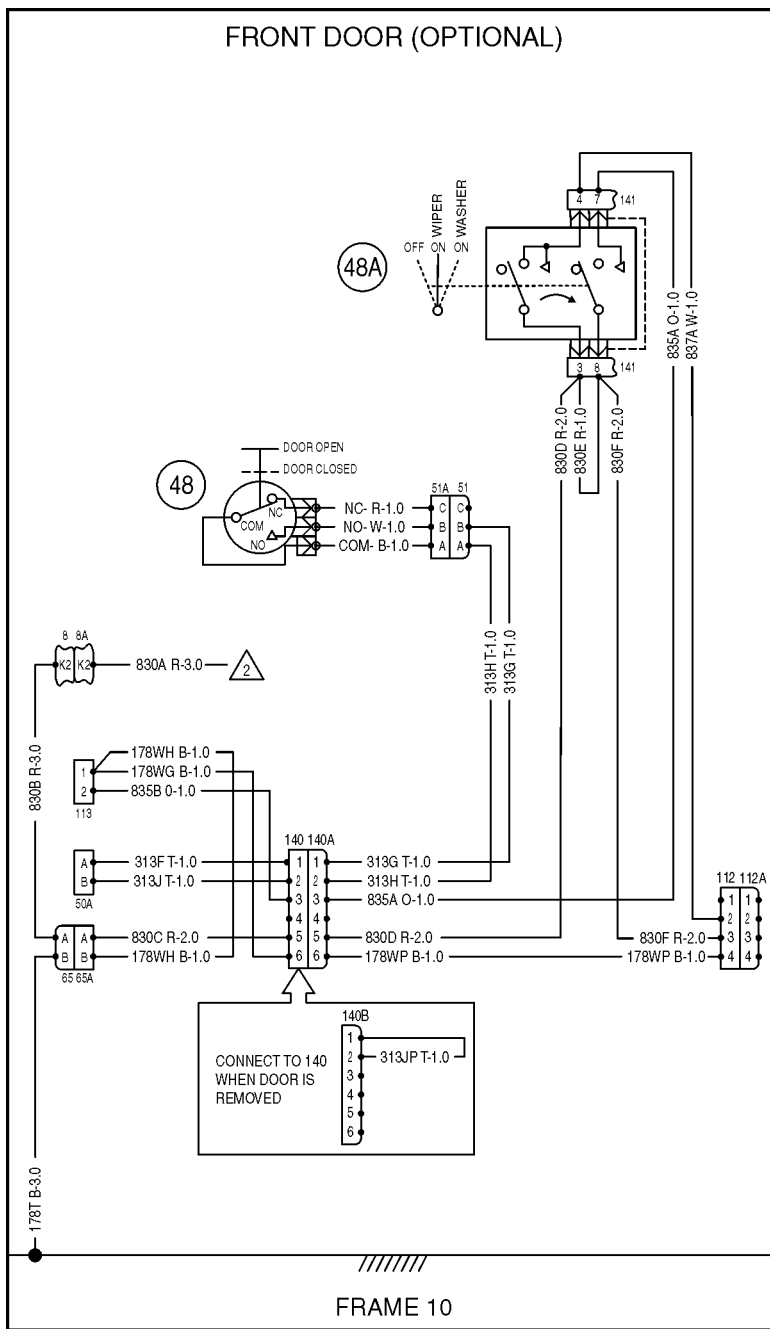

48. CAB DOOR SWITCH

48A. WIPER/WASHER SWITCH

ELECTRICAL SCHEMATIC FRAME 10

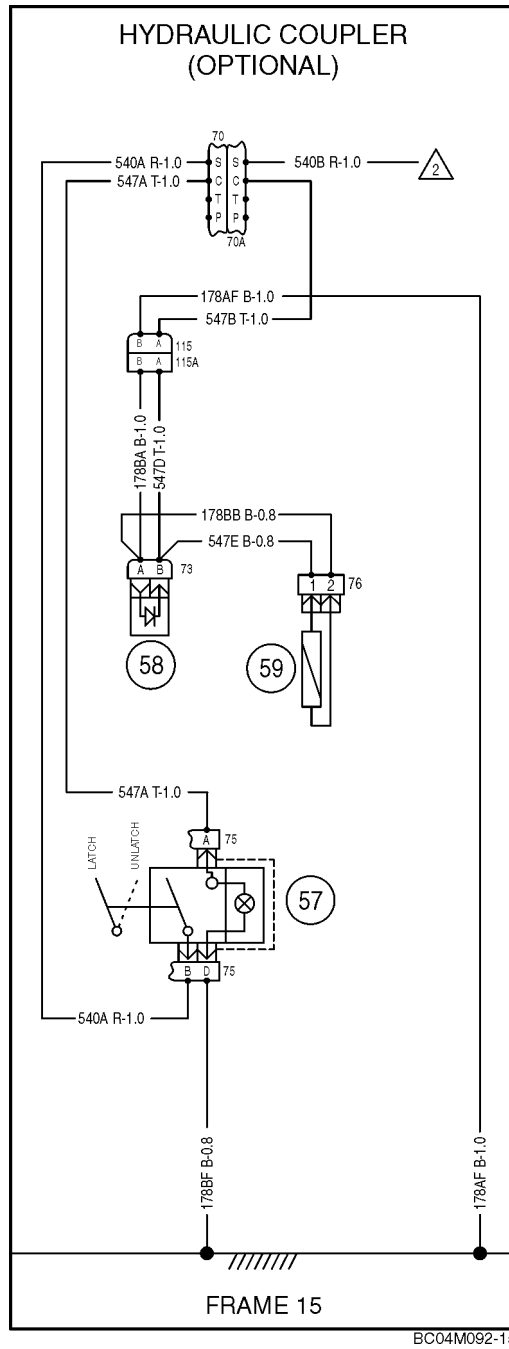

57. HYDRAULIC COUPLER SWITCH
58. DIODE

59. HYDRAULIC COUPLER RELEASE SOLENOID

ELECTRICAL SCHEMATIC FRAME 15

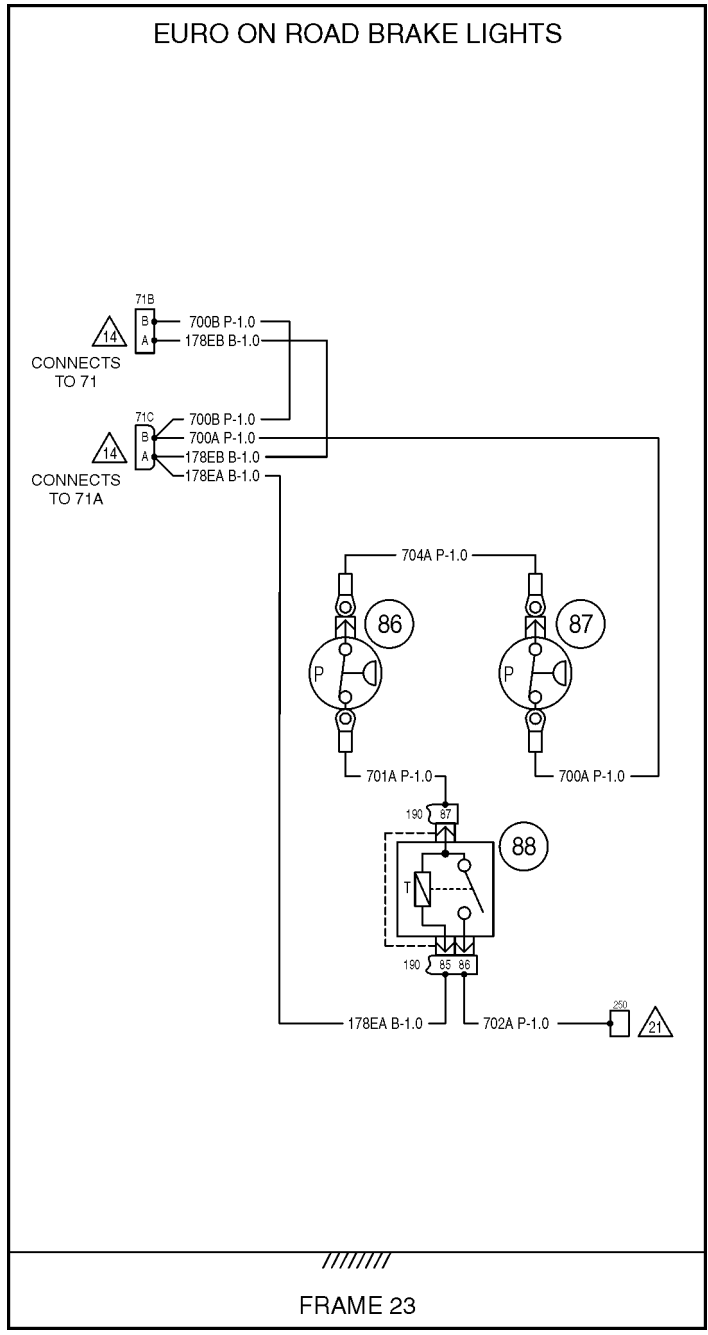

- 85. NOT USED
- 86. LEFT BRAKE LIGHT SWITCH (EURO)

- 87. RIGHT BRAKE LIGHT SWITCH (EURO)
- 88. BRAKE LIGHT SWITCH TIMER RELAY (EURO)

BC04M092-23

ELECTRICAL SCHEMATIC FRAME 23

CONNECTORS SCHEMATIC FRAME 3

Connector 60

<u>Cavity</u>	<u>Circuit ID</u>	<u>Description</u>
1	IVC2 (B) 0.8	From splice
2	IVC4 (B) 0.8	To cold start advance solenoid

Connector 8

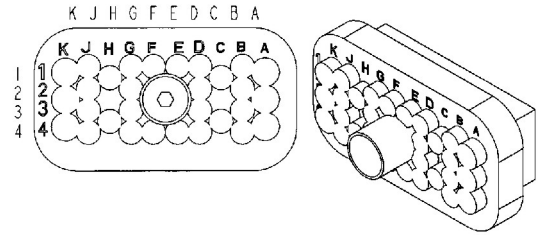

256357A1

<u>Cavity</u>	<u>Circuit ID</u>	<u>Description</u>
C1	311D (T) 1.0	To connector 50 pin B
D2	300E (R) 1.0	To connector 23 pin 24 "IGN ON"
C2	303C (T) 0.5	To connector 59 pin A
D4	258C (T) 0.5	To connector 23 pin 8
J2	602B (W) 0.5	To connector 23 pin 5
D1	319A (T) 0.5	To connector 23 pin 26
H2	311C (T) 1.0	To connector 50 pin A

CONNECTORS SCHEMATIC FRAME 5

Connector 8A

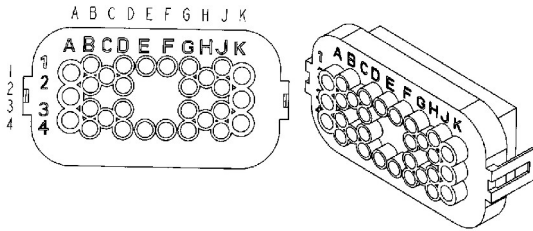

256356A1

<u>Cavity</u>	<u>Circuit ID</u>	<u>Description</u>
C1	311F (T) 1.0	From splice 14
D2	300D (R) 1.0	From splice
C2	303D (T) 1.0	From connector 18 pin 86
D4	258B (T) 1.0	From connector 80 pin 1
J2	602A (W) 1.0	From connector 127 pin A
D1	319B (T) 1.0	From connector 79 pin A
H2	311B (P) 1.0	From connector 18 pin 87

Connector 51A

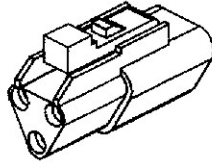
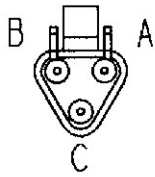

225295C1

Cavity	Circuit ID	Description
A	COM (B) 1.0	To door switch COM Terminal
B	NO (W) 1.0	To door switch NO Terminal
C	NC (R) 1.0	To door switch NC Terminal

Connector 65A

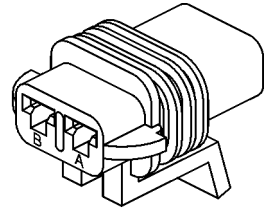
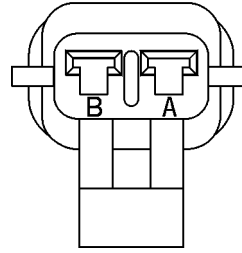

182069A1

Cavity	Circuit ID	Description
A	830C (R) 2.0	To connector 140 pin 5
B	178WH (B) 1.0	From connector 113 pin 1

Connector 65

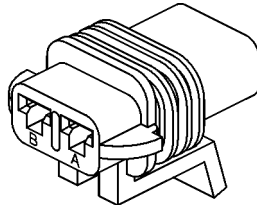
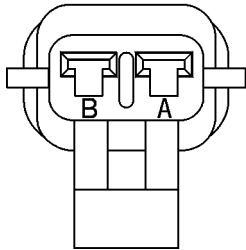

182069A1

Cavity	Circuit ID	Description
A	830B (R) 3.0	From primary fuse block T3
B	178T (B) 3.0	To ground

Connector 112

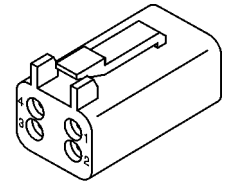
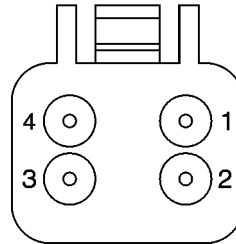

239451A1

Cavity	Circuit ID	Description
2	837a (w) 1.0	To connector 141 pin B
3	830F (R) 2.0	From connector 141 pin 8
4	178WP (B) 1.0	From connector 140A pin 6

Connector 66A



256350A1

Cavity	Circuit ID	Description
A	757A (P) 1.0	To connector 86 pin A
B	751F (R) 1.0	From options fuse block T6
C	756A (P) 1.0	To connector 86 pin C
D	759A (P) 1.0	From connector 70A pin L
E	758B (P) 1.0	To connector 70A pin K
F	754C (P) 1.0	To connector 70A pin N
H	178AN (B) 1.0	To ground

Connector 85

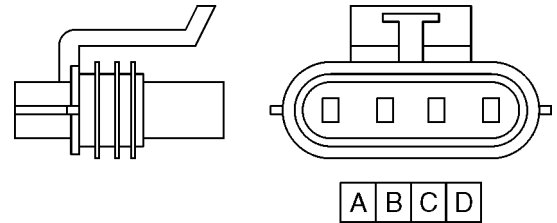

256345A1

Cavity	Circuit ID	Description
A	757B (P) 1.0	To connector 85A pin A option A or connector 85D pin A option D
B	751G (R) 1.0	To connector 85A pin B option A or connector 85D pin B option D
C	756B (P) 1.0	To connector 85A pin C option A or connector 85D pin C option D

Connector 86

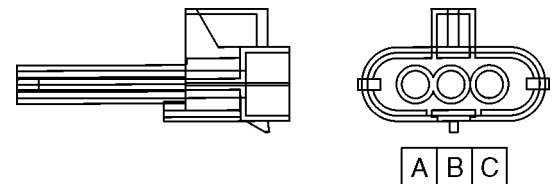

256345A1

Cavity	Circuit ID	Description
A	757A (P) 1.0	To connector 86B pin A
B	178AG (B) 1.0	To ground
C	756A (P) 1.0	To connector 86B pin C

Connector 119

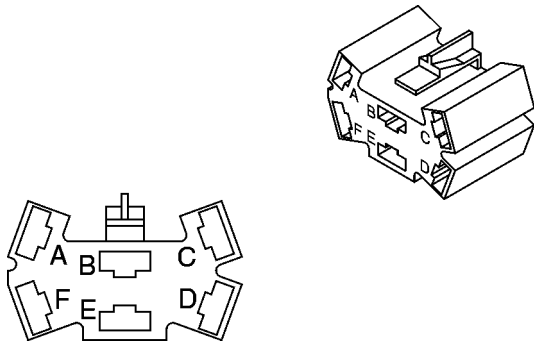

245781C1

Cavity	Circuit ID	Description
E	12B (T) 1.0	To connector 50C pin A
F	13B (T) 1.0	To connector 50D pin A

Connector 71C

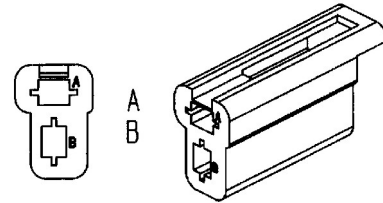

877290R1

Cavity	Circuit ID	Description
A	178EA (B) 1.0	From connector 190 pin 85
A	178EB (B) 1.0	From connector 71B pin A
B	700A (P) 1.0	To right brake light switch
B	700B (P) 1.0	To connector 71B pin B

CONNECTORS SCHEMATIC FRAME 23

Connector 71B (Euro)

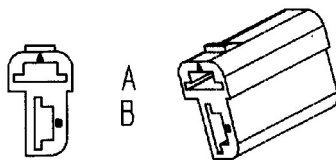

872291R1

Cavity	Circuit ID	Description
A	178EB (B) 1.0	From connector 71C pin A
B	700B (P) 1.0	From connector 71C pin B

Connector 190 (Euro)

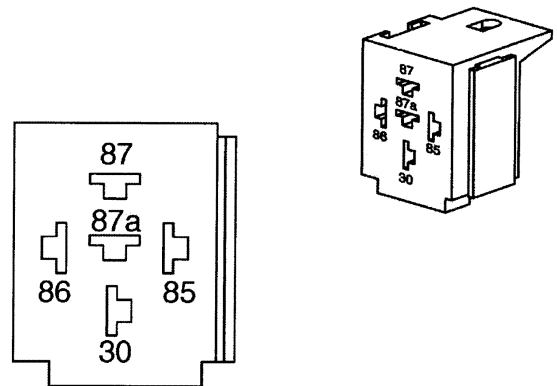

245731C1

Cavity	Circuit ID	Description
86	702A (P) 1.0	To connector 250
87	701A (P) 1.0	To left brake light switch
85	178EA (B) 1.0	To connector 71C pin A

TROUBLESHOOTING ELECTRONIC INSTRUMENT CLUSTER (EIC)

PROBLEM	POSSIBLE CAUSE	CORRECTION
<p>EIC board will not light up when operator sits in the seat.</p>	<p>Faulty seat switch.</p> <p>No battery voltage to seat switch.</p> <p>Blown 5 amp fuse (electronic battery) in engine panel.</p> <p>No battery voltage from seat switch to EIC board.</p> <p>Battery voltage from seat switch to EIC board.</p>	<p>Replace switch</p> <p>Blown 5 amp fuse electronic battery in engine panel, replace fuse. Open in power wire from 5 amp fuse from supply, check and/or replace battery. No battery voltage to 5 amp fuse from supply, check and/or replace battery.</p> <p>Replace fuse.</p> <p>Open in power wire from seat switch to EIC board, repair open wire. Poor or no connection at EIC board, repair connection.</p> <p>If battery voltage from seat to board is OK, replace the EIC.</p>
<p>EIC backlighting is dim.</p>	<p>Brightness variations due to production differences between models and/or EIC board changes.</p> <p>Backlights dim when the loader worklights are activated.</p>	<p>None -- overlay decal material variations cause differences in brightness.</p> <p>None -- EIC board circuitry automatically dims the backlighting when then worklights are on, to reduce the glare at night.</p>

CHARGING GUIDE FOR MAINTENANCE FREE BATTERIES		
Recommended Rate * and Time for Fully Discharged Battery		
Battery Capacity - See Reserve Capacity under Specifications	Slow Charge	Fast Charge
80 Minutes or Less	10 Hours at 5 Amperes 5 Hours at 10 Amperes	2.5 Hours at 20 Amperes 1.5 Hours at 30 Amperes
Above 80 to 125 Minutes	15 Hours at 5 Amperes 7.5 Hours at 10 Amperes	3.75 Hours at 20 Amperes 1.5 Hours at 50 Amperes
Above 125 to 170 Minutes	20 Hours at 5 Amperes 10 Hours at 10 Amperes	5 Hours at 20 Amperes 2 Hours of 50 Amperes
Above 170 to 250 Minutes	30 Hours at 5 Amperes 15 Hours at 10 Amperes	7.5 Hours at 20 Amperes 3 Hours at 50 Amperes
* Initial rate for standard taper charger.		

NOTE: A maintenance free battery will have the words *Maintenance Free* on the decal on the top of the battery. If the center part of the decal has been removed to get access to the battery caps, it is possible the words *Maintenance Free* will have been removed from the decal.

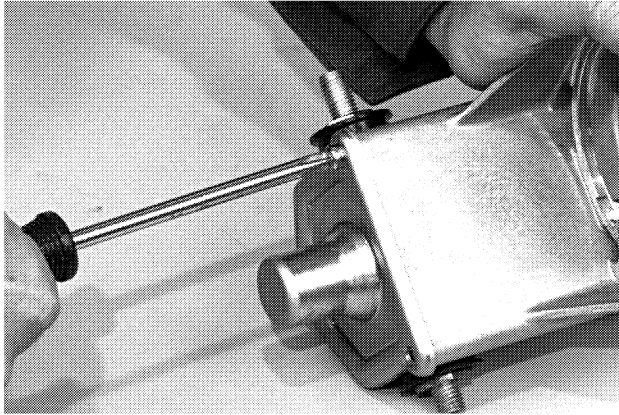
STEP 18

B330706M

Loosen and remove the screws that hold the cover.

STEP 19

If necessary, use a hammer to loosen the cover.

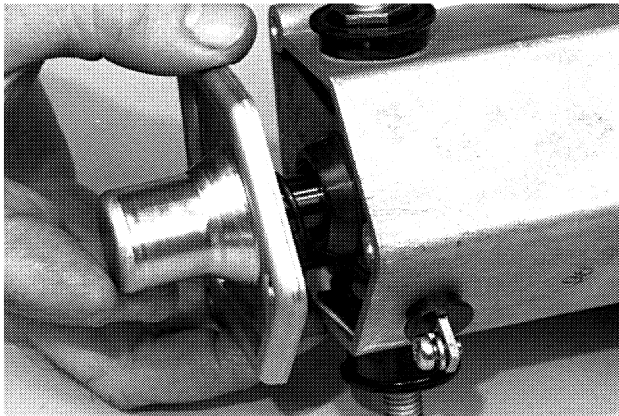
STEP 20

B330708M

Remove the cover.

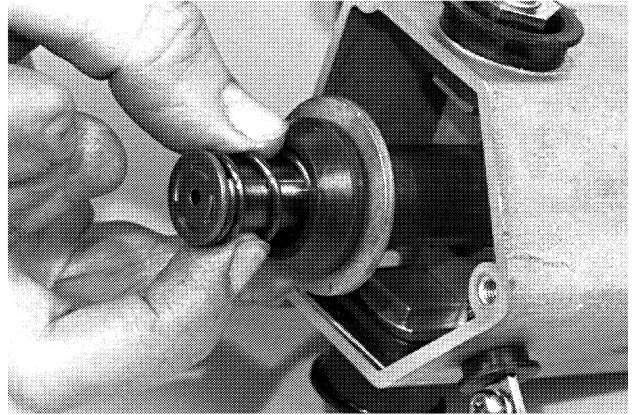
STEP 21

B330709M

Remove the plunger.

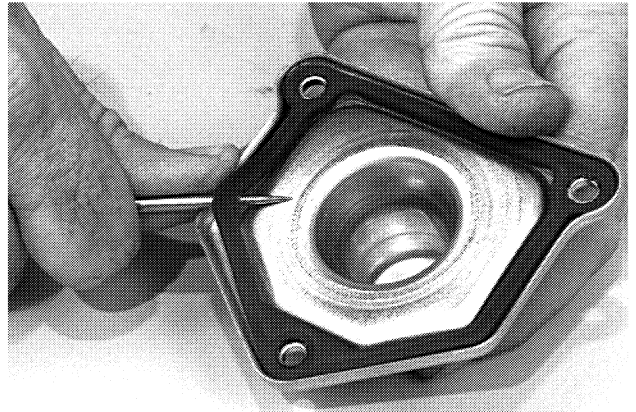
STEP 22

B330710M

If necessary, remove the gasket from the cover.

INSPECTION

All parts except the starter drive must be cleaned using mineral spirits and a brush or cloth. Use a clean, dry cloth to clean the starter drive.

Brushes and Brush Springs

1. If the length of the brush fastened to the brush holder is less than 11 mm (7/16 inch), a new brush holder assembly must be used when the starter is assembled.
2. If the length of a brush fastened to the field coil is less than 11 mm (7/16 inch), a new field frame assembly must be used when the starter is assembled.

3. Use a spring scale to check the tension of the brush springs. Pull the brush spring up until the brush spring is just above the brush holder. The scale indication must be between 1.8 and 4.1 kg (4 and 9 pounds). If a brush spring is not as specified, use a new brush spring when the starter is assembled.

Brush Holder

1. Hold the leads of an ohmmeter against the frame and the brush holders that have insulation between the brush holder and frame.

**Insert
Tab 5**

ADJUSTING THE RUBBER TRACK TENSION

Increasing Track Tension



WARNING: Use caution when adjusting track tension. Grease is under extreme pressure.

STEP 1

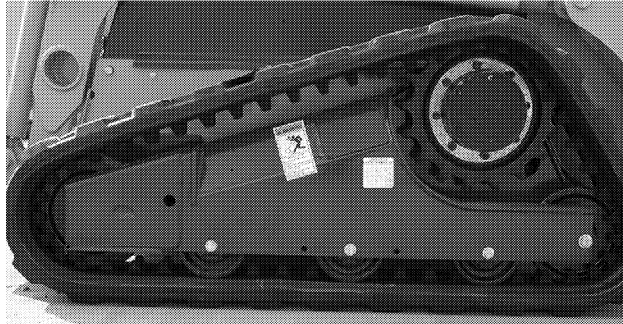

BD06A060

Park the machine on a level surface with the bucket approximately 125 mm (5 inches) off of the ground and stop the engine.

STEP 2

Place 101 mm (4 inch) blocks on the ground under the bucket. Enter the operators compartment and start the engine and lower the bucket until the front of the machine is raised off the ground. Stop the engine and exit the operators compartment. Place a floor jack under the rear of the machine and raise the rear of the machine until the tracks are completely off the ground. Install blocks under the machine to securely block the machine in the raised position with the tracks off the ground.

STEP 3

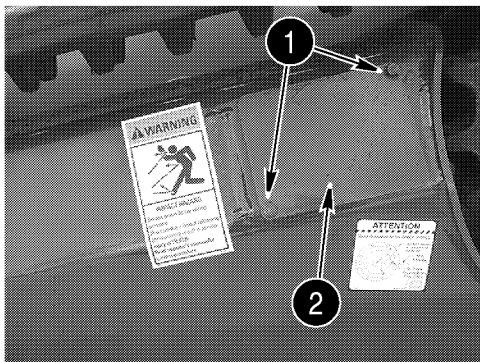

BD06A062

Remove the screws (1) from the adjuster cover (2) and remove the cover (2).

STEP 4

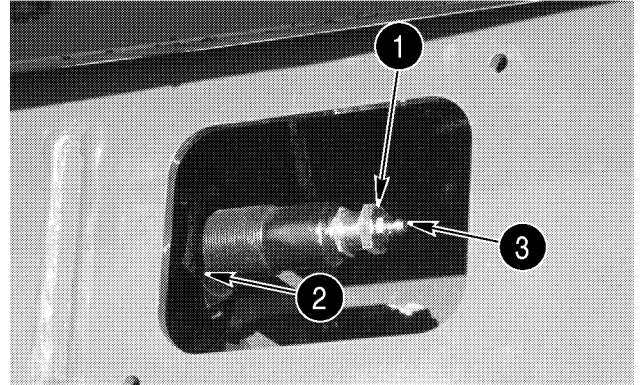

BD05C011

Tighten the grease valve (1) to a torque of 90 ± 10 Nm (66 ± 10 pound-feet). Install a power grease gun on the grease zerk (3) on the end of the grease valve.

To tighten the track, apply grease to the adjuster (2) to increase tension on the track.

NOTE: DO NOT remove the grease valve body from the adjuster. Internal parts (ball, spring, and poppet) may be lost.

STEP 5

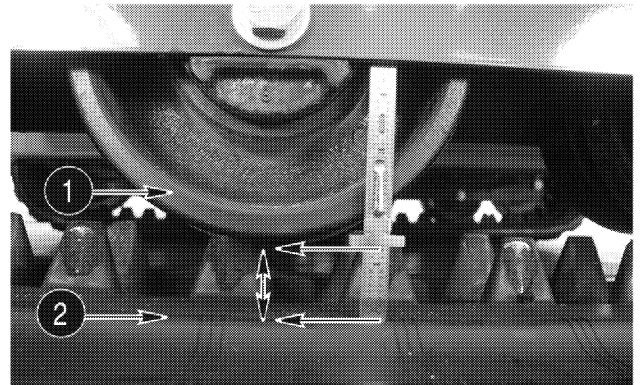

BD05C014_1

Apply grease to the adjuster until the distance from the bottom of the center roller (1) to the top surface of the track (2) is within 12 to 19 mm (0.47 to 0.75 inches).

Installation

STEP 4

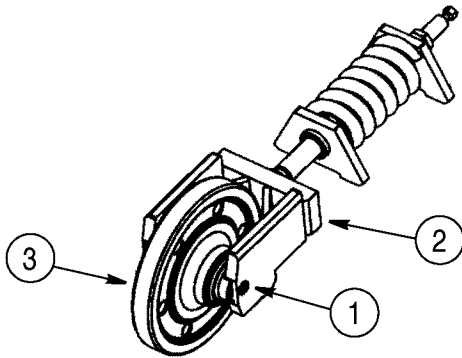

BS05C134

Install the front idler wheel (3) into the yoke (2). Install the mounting screw (1) in the yoke (2) and into the front idler wheel (3). Tighten the screw (1) to a torque of 183 to 205 Nm (136 to 153 pound-feet).

STEP 5

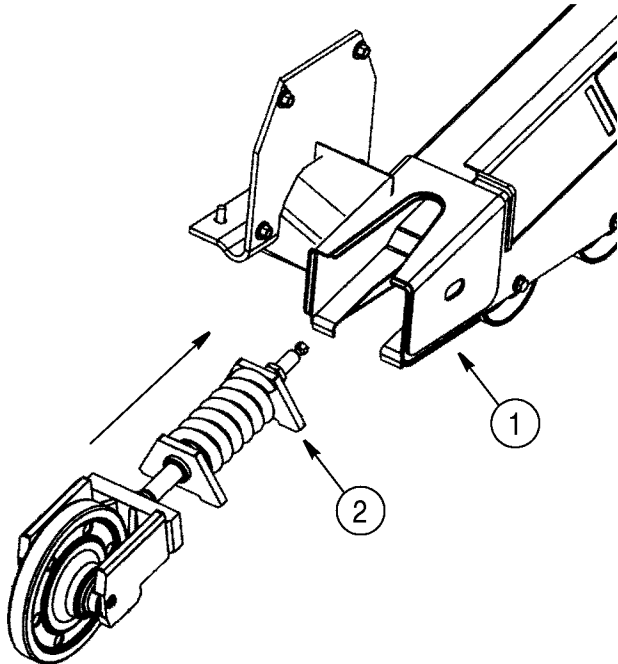

BS05C135

Slide the track tension assembly (2) into the main frame (1).

STEP 6

After the track tension assembly has been installed, refer to Section 5001 Rubber Track and follow the procedure for installing the track.

STEP 7

After the track has been installed, refer to Section 5001 Adjusting the Rubber Track Tension and adjust the tension of the track.

SPECIFICATIONS

Hydrostatic Pump

Manufacturer	Sauer-Danfoss
Type	Tandem axial piston
Model	46
Displacement (410 and 420 Machines).....	34.7 cc (2.12 in ³)
Displacement (420CT Machines).....	42.9 cc (2.62 in ³)
Displacement (430,440 and 440CT Machines).....	46 cc (2.81 in ³)
Pump Control Style	Servo
System Relief Pressure - 410,420,430 and 440 Machines (forward and reverse).....	29,992 kPa (4350 psi)
System Relief Pressure - 420CT and 440CT Machines (forward and reverse).....	34,494 kPa (5003 psi)
Charge Oil Source.....	Integral charge pump gerotor type
Charge Pump Displacement	23 cc (1.4 in ³)
Charge Pressure (minimum at full throttle).....	2482 kPa (24.8 bar) (360 psi)
Charge Flow (410, 420 and 420CT Machines) (approximate, depends on motor and pump leakage)	72.3 L/min (19.1 gpm)
Charge Flow (430 and 440 Machines) (approximate, depends on motor and pump leakage)	56 L/min (14.8 gpm)
Charge Flow (440CT Machines) (approximate, depends on motor and pump leakage)	52.6 L/min (13.9 gpm)
Pump Flow at Rated Engine RPM (410, 420 and 420CT Machines).....	109 L/min (28.9 gpm)
Pump Flow at Rated Engine RPM (430 and 440 Machines).....	113 L/min (29.8 gpm)
Pump Flow at Rated Engine RPM (440CT Machines).....	124 L/min (32.9 gpm)
Pump RPM/Engine RPM Ratio	1:1

Hydrostatic Drive Motors (410 Machines)

Manufacturer	Rexroth
Type	Radial Piston
Model	MCR03
Displacement	
Maximum	400 cc (24.4 in ³)
Minimum	N/A
Speed at High Idle Minus 50 Engine RPM.....	260 RPM
Low Range Torque	
At Relief Pressure and 86% Efficiency	1719 Nm (1267.8 pound-feet)
Shuttle Oil Flow Per Motor	N/A

Hydrostatic Drive Motors (420 Machines)

Manufacturer	Eaton
Type	Geroler
Model	VIS40
Displacement	
Maximum	503 cc (30.7 in ³)
Minimum	N/A
Speed at High Idle Minus 50 Engine RPM.....	260 RPM
Low Range Torque	
At Relief Pressure and 86% Efficiency	1928 Nm (1422 pound-feet)
Shuttle Oil Flow Per Motor	N/A

Hydrostatic Final Drive Motors (420CT Machines)

Manufacturer	Rexroth
Type	Radial Piston
Model	N/A

TORQUE SPECIFICATIONS

Tandem Pump to Bracket Mounting Bolts (Apply Loctite 243 to the Threads).....	110 to 122 Nm (80 to 90 pound-feet)
Tandem Pump Mounting Bracket to Chassis Mounting Bolts (Apply Loctite 243 to the Threads).....	54 to 60 Nm (40 to 44 pound-feet)
410 Hydraulic Drive Motor Mounting Bolts	56 Nm (40 pound-feet) plus Turn Additional 65°
420 Hydraulic Drive Motor Mounting Bolts (Apply Loctite 243 to the Threads).....	122 Nm (90 pound-feet) plus Turn Additional 60°
420CT Final Drive Motor Mounting Bolts	
Initial Torque (Tighten in star Pattern)	67 to 163 Nm (50 to 120 pound-feet)
Final Torque (Tighten in star Pattern).....	183 to 205 Nm (136 to 153 pound-feet)

Installation

STEP 11

Use acceptable lifting equipment and install the drive motor / brake assembly into the chassis mounting location.

STEP 12

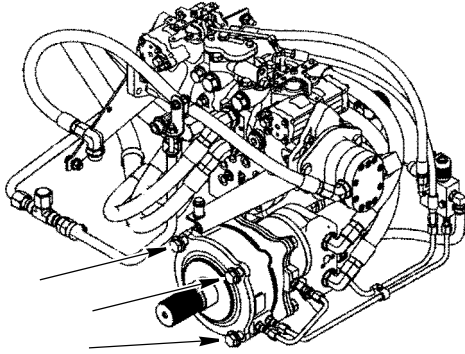

BS05C072

Install the mounting bolts and nuts inside the chain tank into the drive motor mounting flange. Tighten the bolts to a torque of 122 Nm (90 pound-feet) plus turn additional 60°.

STEP 13

Start the vacuum pump.

STEP 14

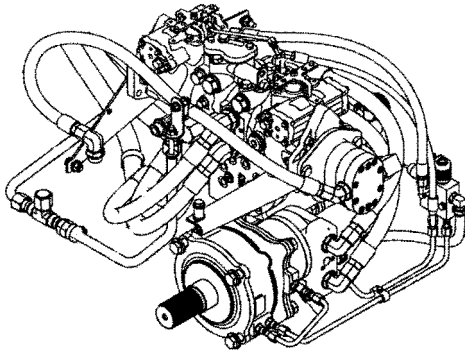

BS05C072

Remove the caps from the fittings and plugs from the hoses. Install and tighten all of the hoses and hydraulic lines on the drive motor.

STEP 15

If the tandem pump was removed, install the tandem pump.

STEP 16

Stop the vacuum pump. Disconnect the vacuum pump from the reservoir. Install the cap on the hydraulic reservoir.

STEP 17

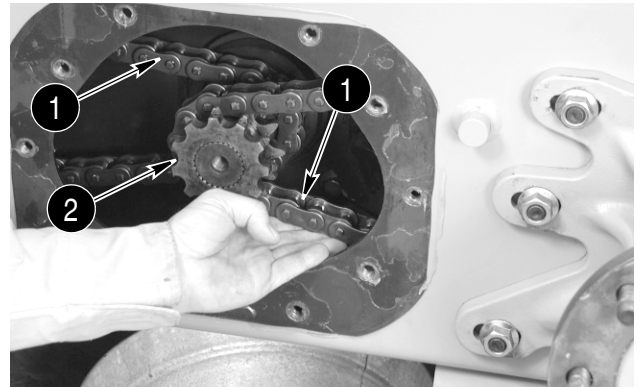

BD01F305

Install the drive chains (1) onto the drive sprocket (2).

STEP 18

See Section 6007 for the procedure to adjust the drive chain tension.

STEP 19

Adjust the drive chain tension.

STEP 20

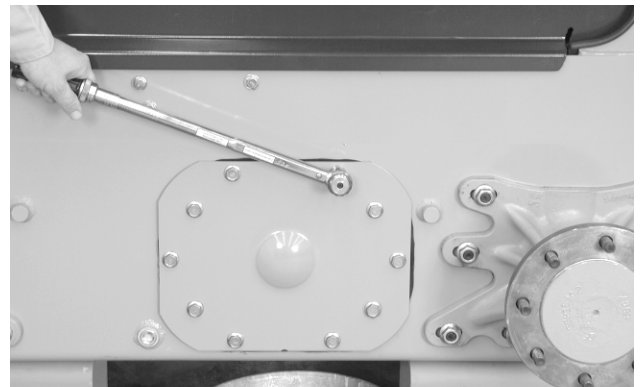

BD01C258

Remove the old sealant and apply new RTV sealant between the gasket, cover, and the chassis. Install the chain tank cover and the bolts onto the chassis. Tighten the bolts to a torque of 125 to 150 Nm (93 to 112 pound-feet).

TORQUE SPECIFICATIONS

Bolts for Pump Drive Joint94 to 106 Nm (69 to 78 pound-feet)

CLICK HERE TO **DOWNLOAD** THE COMPLETE MANUAL

- Thank you very much for reading the preview of the manual.
- You can download the complete manual from: www.heydownloads.com by clicking the link below



- Please note: If there is no response to CLICKING the link, please download this PDF first and then click on it.

CLICK HERE TO **DOWNLOAD** THE COMPLETE MANUAL

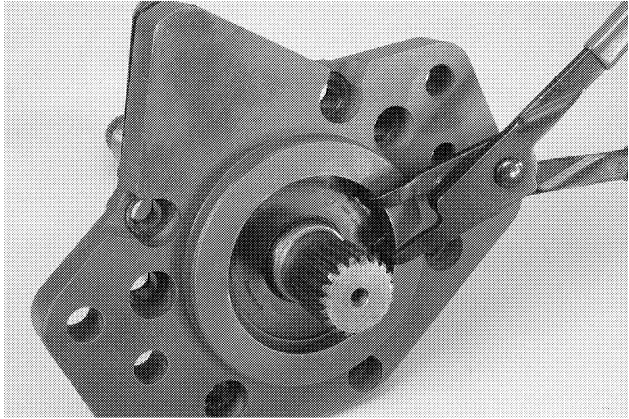
STEP 19

BD01H200

Remove the snap ring (2) from the seal (1).

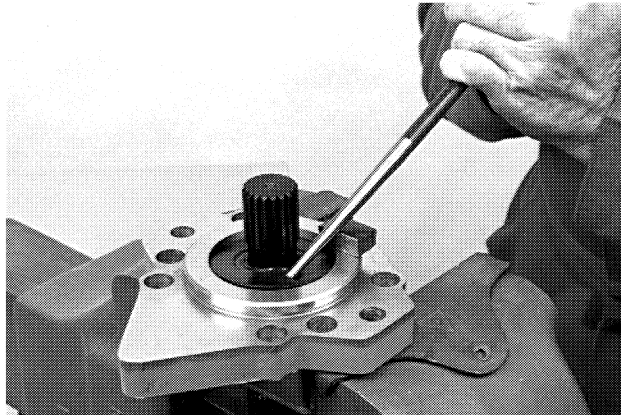
STEP 20

B5182721

Fasten the cover (9) in a vise with soft jaws. Use a prybar to remove the seal (1).

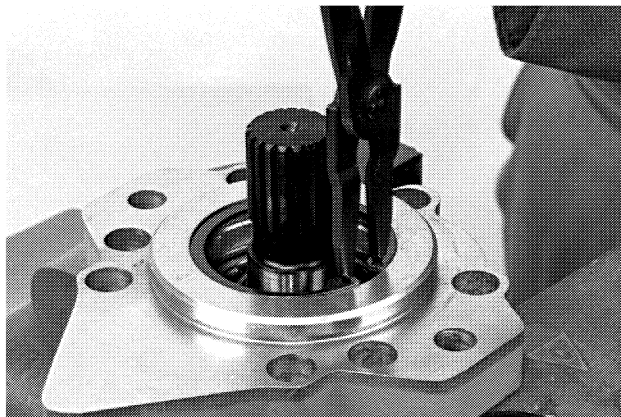
STEP 21

B518724

Remove the snap ring (3).

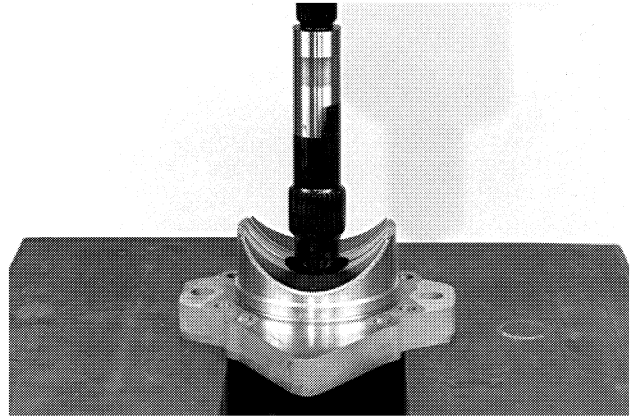
STEP 22

B518727

Press the shaft (5) out of the cover (9). Inspect the bearing on the shaft. Replace if necessary.

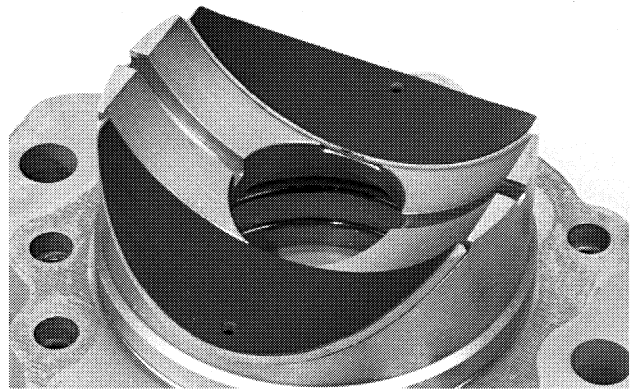
STEP 23

B518840

Inspect the bearings (4) on the cover (9). If the yellow surface has worn through to the dark base, use new bearings.

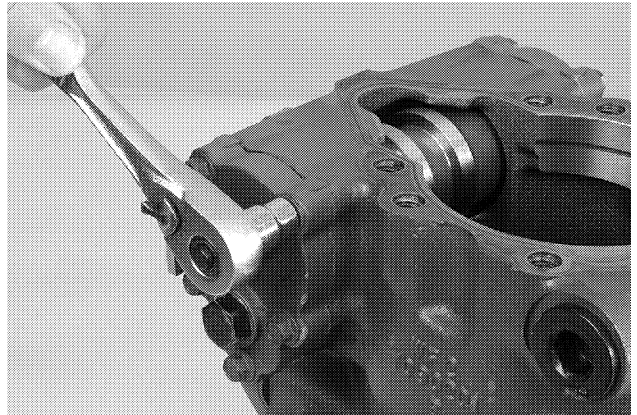
STEP 24

BD01H201

Remove the screws (3) from the cover (6), see the illustration on page 16.

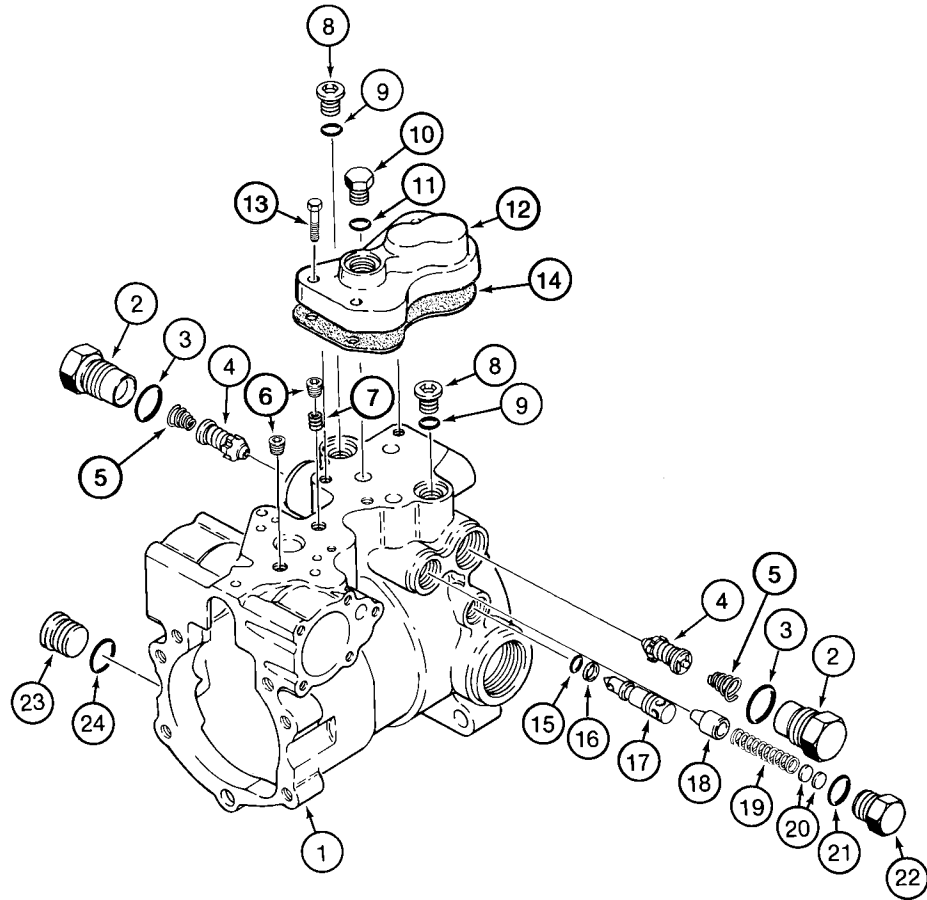

- | | | | |
|-----------------|--------------|-------------------|--------------|
| 1. HOUSING | 7. PLUG | 13. BOLT | 19. SPRING |
| 2. PLUG | 8. HEX PLUG | 14. SEAL | 20. SHIM KIT |
| 3. O-RING | 9. O-RING | 15. O-RING | 21. O-RING |
| 4. RELIEF VALVE | 10. HEX PLUG | 16. BACKUP RING | 22. HEX PLUG |
| 5. SPRING | 11. O-RING | 17. BY-PASS VALVE | 23. PLUG |
| 6. PLUG | 12. ADAPTER | 18. VALVE POPPET | 24. O-RING |

REAR PUMP VALVES, PLUGS, AND ADAPTER

BS03D066

STEP 105

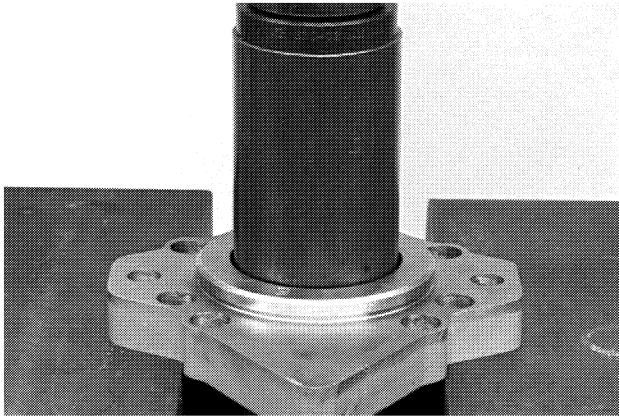

B518904

Lubricate the lip of the seal (1) with clean oil. Carefully press the new seal (1), with the lip down, into the cover (9).

STEP 106

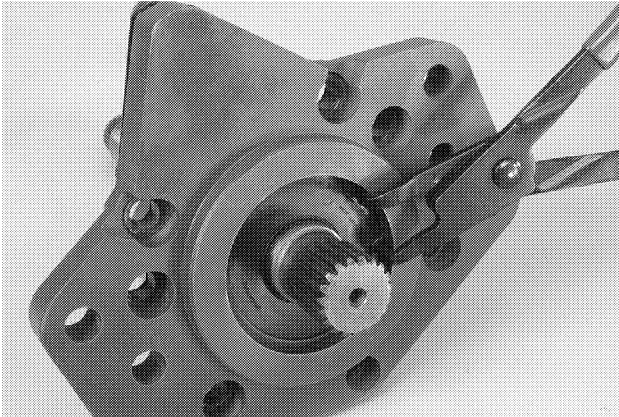

BD01H200

Install the other snap ring (2).

STEP 107

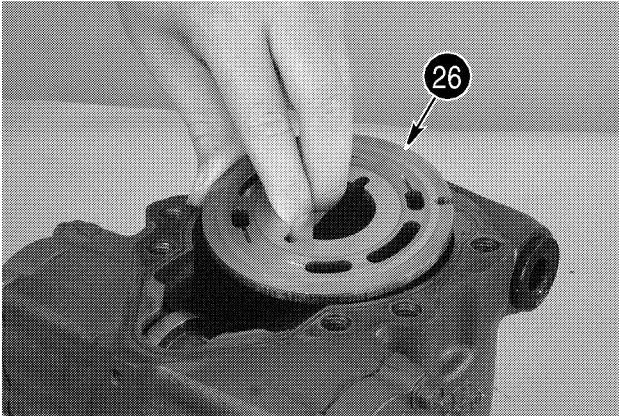

BD01H197

Install the wear plate (26) with the bronze surface up. Make sure the notch in the wear plate engages the roll pin. Lubricate the wear plate (26) with clean oil.

STEP 108

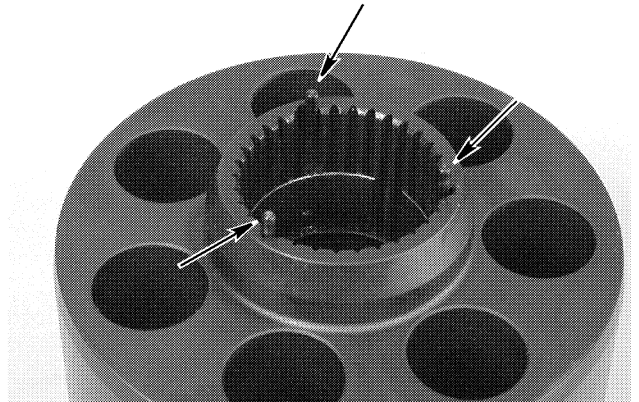

BD01H198

Make sure the three pins (20) are installed in the cylinder block (21).

STEP 109

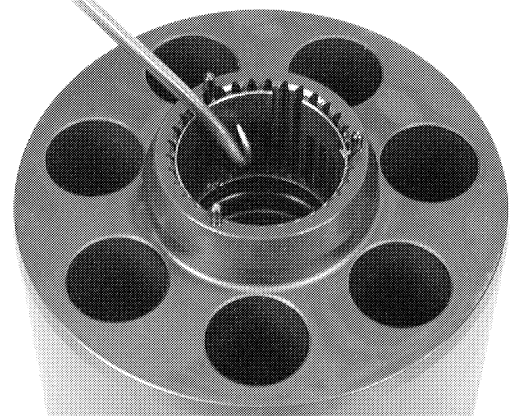

BD01H247

Pull the pin retaining collar (19) up to the top of the splines.

STEP 110



BD01H196

Install the cylinder block (21) into the pump.

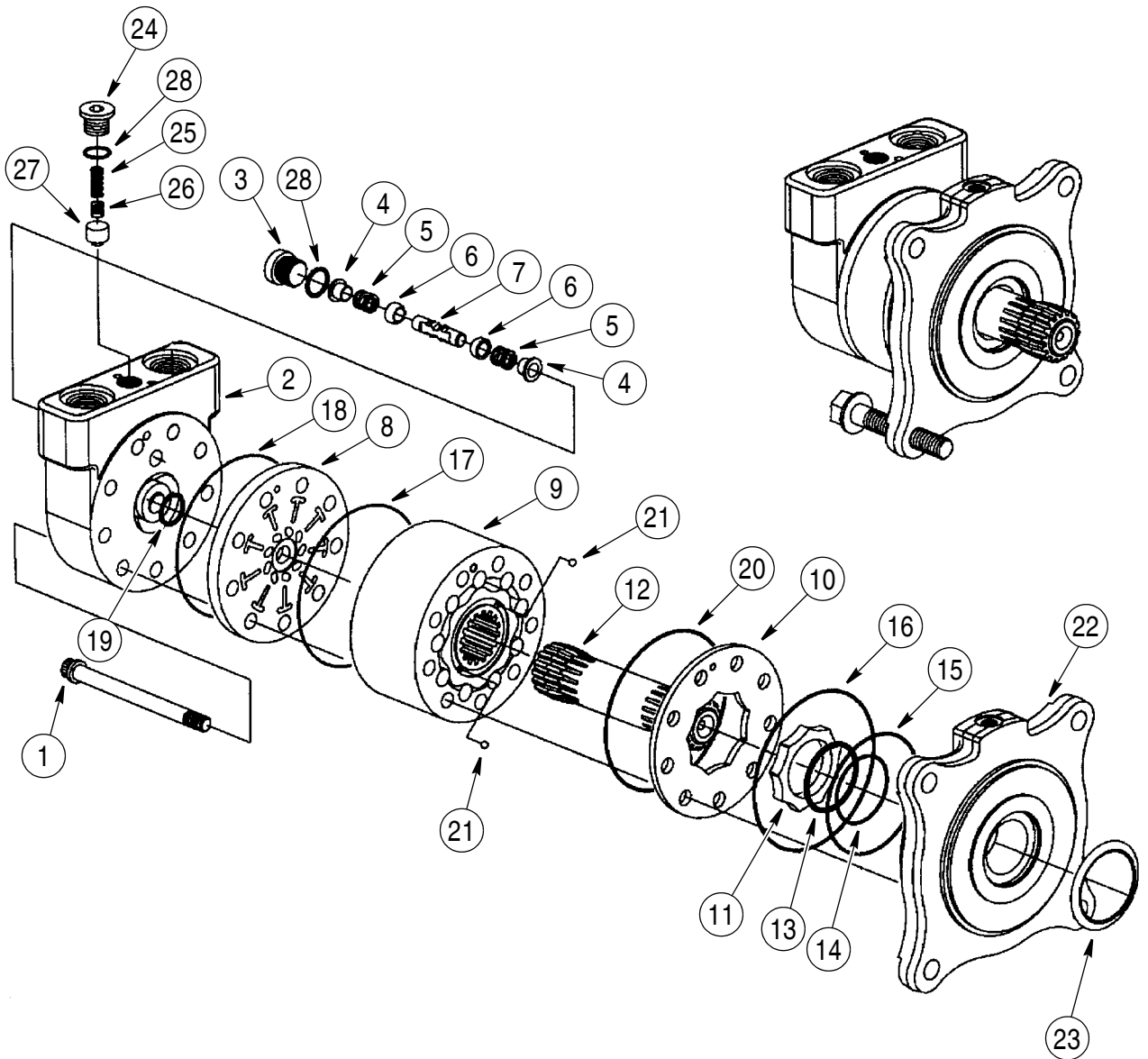

- | | | | |
|-------------------|------------------------|----------------|------------|
| 1. BOLT | 8. VALVE PLATE | 15. O-RING | 22. FLANGE |
| 2. END COVER | 9. GEROTOR ASSEMBLY | 16. SEAL | 23. SEAL |
| 3. PLUG | 10. OUTER THRUST PLATE | 17. SEAL | 24. PLUG |
| 4. DASH POT | 11. INNER THRUST PLATE | 18. SEAL | 25. SPRING |
| 5. SPRING | 12. DRIVE SHAFT | 19. O-RING | 26. SHIM |
| 6. POPPET | 13. BACKUP RING | 20. SEAL | 27. POPPET |
| 7. SHUTTLE PISTON | 14. O-RING | 21. CHECK BALL | 28. O-RING |

DRIVE MOTOR

BS01M202

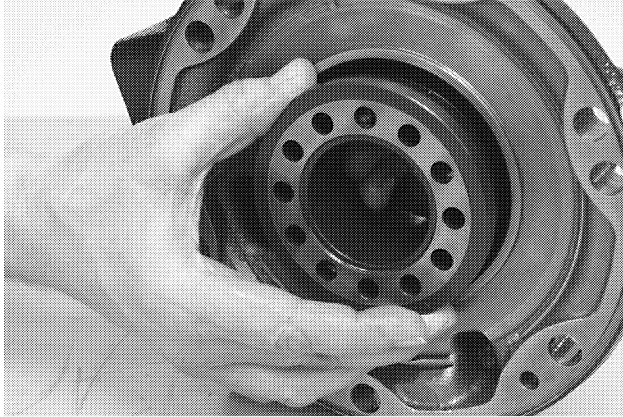
STEP 25

BD04E031

Remove the distributor from the rear case.

STEP 26

BD04E032

Make a record of the number of springs and the stop pin location in the distributor for use during the assembly procedure.

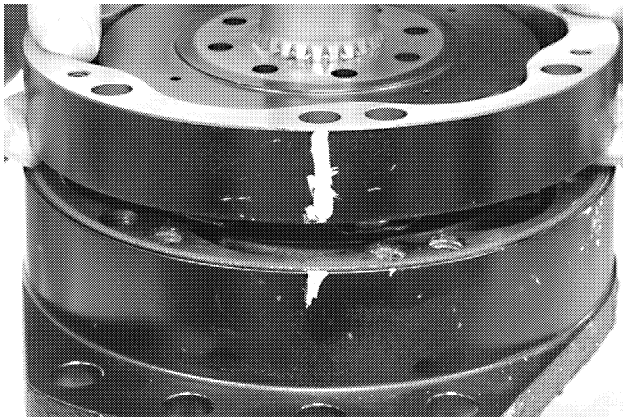
STEP 27

BD04E033

Remove the cam from the front case.

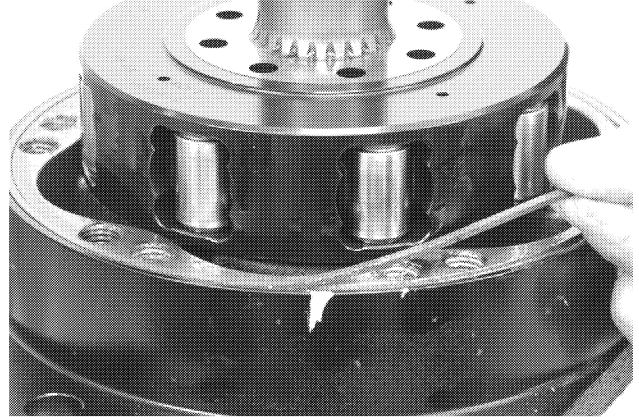
STEP 28

BD04E034

Remove the seal from the front case.

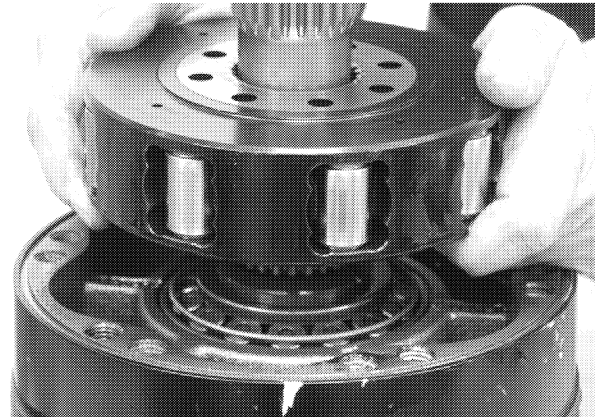
STEP 29

BD04E035

Remove the cylinder block from the front case.

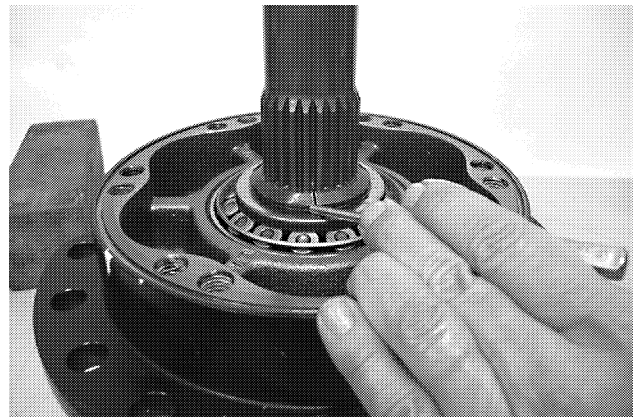
STEP 30

BD04E041

Place the front case assembly in the press. Use acceptable tools and remove the split ring from the shaft.

TORQUE SPECIFICATIONS

Nuts for Axle Housings	223 to 265 Nm (165 to 195 pound-feet)
Wheel Nuts (Stamped Center Wheels with Tapered Type Lug Nuts)	135 to 163 Nm (100 to 120 pound-feet)
Wheel Nuts (Solid Center Wheels with Flange Type Lug Nuts)	224 to 265 Nm (165 to 195 pound-feet)
Bolts for Chain Tank	101 to 113 Nm (93 to 112 pound-feet)
Bolts for Drive Sprockets	247 to 320 Nm (185 to 235 pound-feet)

(All threads are to be clean and free of rust, dirt and oil. Apply Loctite 243 to the first 10 to 15 threads of the cap screw)

NOTE: *Be sure to recheck the wheel nuts every two hours until the wheel nuts remain tight. See Operations Manual.*

Axle Assembly

STEP 11



BP96K033

Start the inner bearing cup into the axle housing.

STEP 12

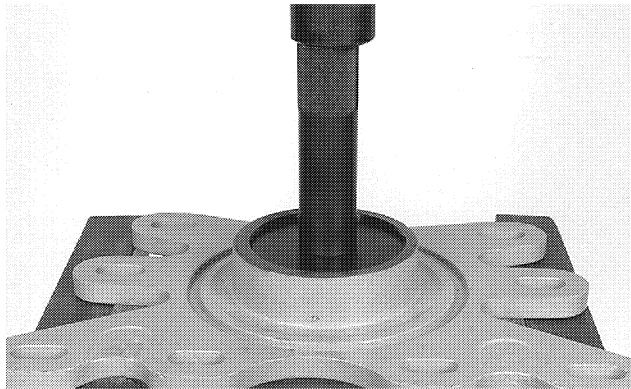

BP96K034

Use an acceptable driver to press the bearing cup into the axle housing. Press the cup until it is seated against the axle housing shoulder.

STEP 13

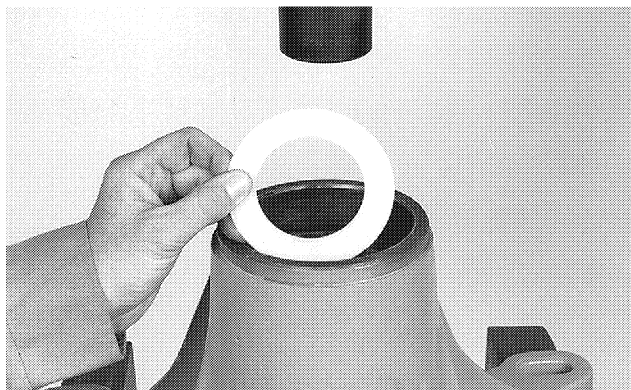

BP96K024

Turn the axle housing over and install the outer plastic grease disc into the axle housing.

STEP 14

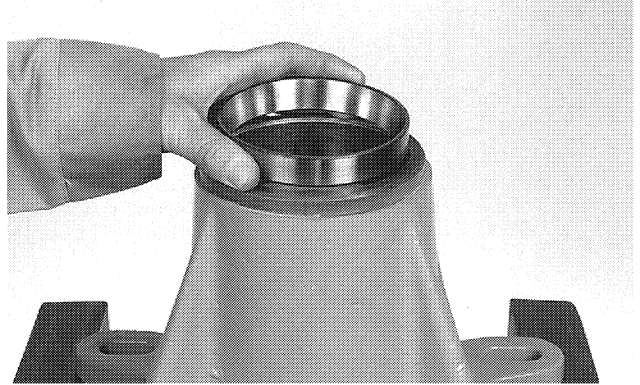

BP96K035

Start the outer bearing cup into the axle housing.

STEP 15

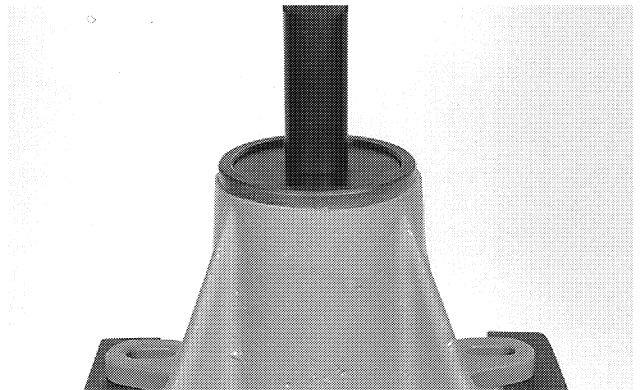

BP96K036

Use an acceptable driver to press the bearing cup into the axle housing. Press the cup until it is seated against the axle housing shoulder.

STEP 16

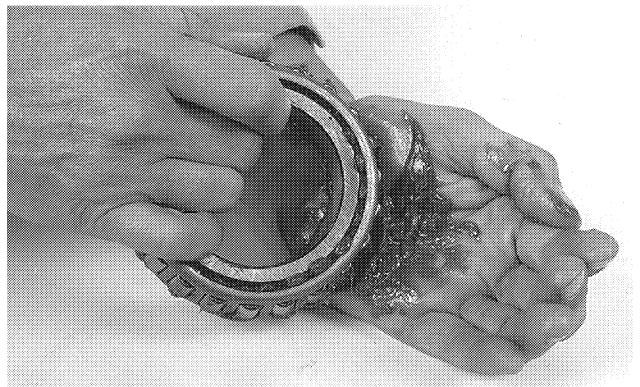

BP96K037

Use No. 2 lithium wheel bearing grease to fill the bearings.

SECTION INDEX

BRAKES

Section Title	Section Number
Removal and Installation of Brake Components	7002
410 Brakes - Spring Applied - Hydraulic Release (Refer to Section 6005 - Single Speed Drive Motor)	
420 Brakes - Spring Applied - Hydraulic Release	7004

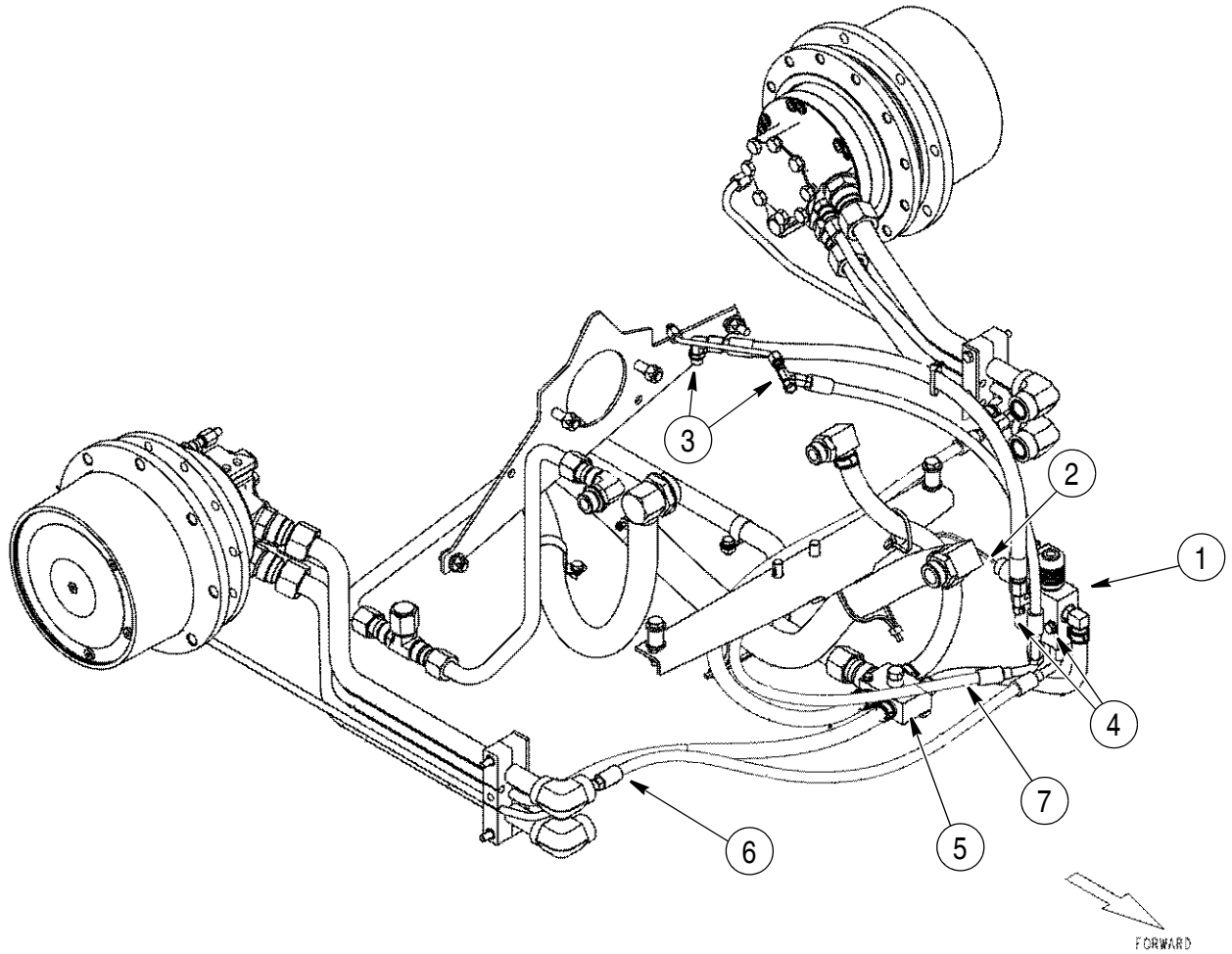

- 1. BRAKE SOLENOID VALVE
- 2. WIRING HARNESS
- 3. HYDRAULIC HOSE
- 4. MOUNTING BOLTS

- 5. MANIFOLD VALVE
- 6. RIGHT HAND BRAKE LINE
- 7. LEFT HAND BRAKE LINE

BS06E238

420CT BRAKE SOLENOID VALVE INSTALLATION

STEP 26



BD00M182

- 1. SEAL

Lubricate a new seal (1) with clean SAE 10W30 oil. Install the seal into the groove of the sprocket housing.

STEP 27



BD00M188

- 1. BEARING CONE
- 2. SPROCKET HOUSING
- 3. PISTON

Install the bearing cone (1) into the sprocket housing (2).

NOTE: This photo is for reference only. The piston is installed in step 33.

STEP 28

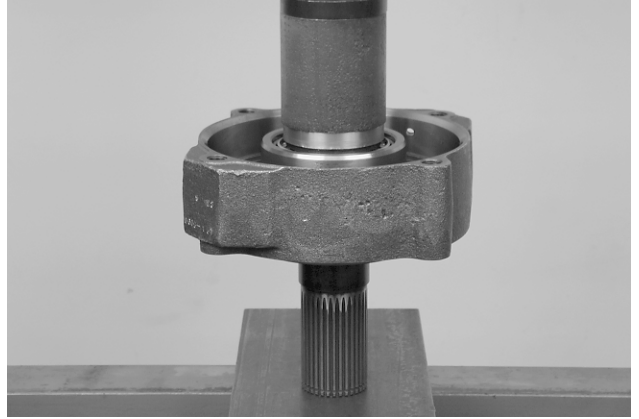

BD00M197

Install the sprocket housing onto the shaft. Place the assembly on the press as shown and press the bearing cone into place.

NOTE: Make sure when installing the sprocket housing onto the shaft that you avoid damaging the seal.

STEP 29

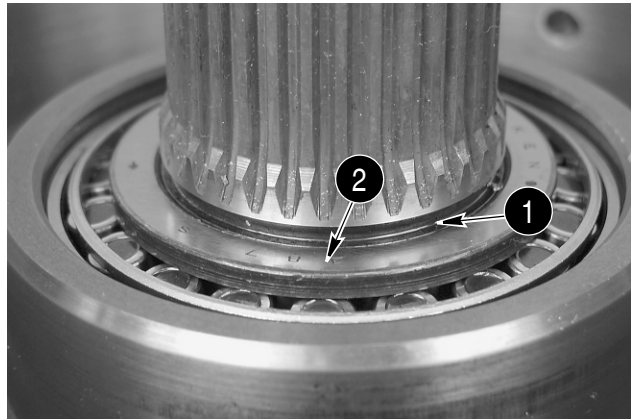

BD00M198

- 1. SNAP RING GROOVE
- 2. BEARING CONE

Measure the gap between the bearing cone (2) and the snap ring groove (1) to determine the appropriate size snap ring to install.

IMPORTANT: It is critical that the sharp (non-rolled) side of the snap ring is opposite of the bearing cone.

Section 8001

HYDRAULIC SYSTEM TROUBLESHOOTING AND SCHEMATICS

METRIC MEASURE CHECK SHEET

Owner _____ Date _____ Hours _____

Model _____ Product Identification Number _____

Oil Temperature: At start of test _____ °C. At end of test _____ °C.

Test No. 1 - Gear Pump

- | | |
|---|---|
| 1. _____ L/min at min. pressure at 2200 r/min | 3. _____ L/min at 124 bar at 2200 r/min |
| 2. _____ L/min at 97 bar at 2200 r/min | 4. _____ L/min at 152 bar at 2200 r/min |

The efficiency of the gear pump is line 4 divided by line 1.

Test No. 2 - Loader Circuits and Main Relief Valve

- | | |
|---|--------------------------------------|
| 5. Main relief valve begins to open at _____ bar | 9. Lift _____ L/min at 124 bar |
| 6. Main relief valve completely open at _____ bar | 10. Lower _____ L/min at 124 bar |
| 7. Rollback _____ L/min at 124 bar | 11. Auxiliary _____ L/min at 124 bar |
| 8. Dump _____ L/min at 124 bar | 12. Auxiliary _____ L/min at 124 bar |

U.S. MEASURE CHECK SHEET

Owner _____ Date _____ Hours _____

Model _____ Product Identification Number _____

Oil Temperature: At start of test _____ °F. At end of test _____ °F.

Test No. 1 - Gear Pump

- | | |
|---|--------------------------------------|
| 1. _____ gpm at min. pressure at 2000 rpm | 3. _____ gpm at 1800 psi at 2000 rpm |
| 2. _____ gpm at 1400 psi at 2000 rpm | 4. _____ gpm at 2200 psi at 2000 rpm |

The efficiency of the gear pump is line 4 divided by line 1.

Test No. 2 - Loader Circuits and Main Relief Valve

- | | |
|---|-------------------------------------|
| 5. Main relief valve begins to open at _____ psi | 12. Auxiliary _____ gpm at 1800 psi |
| 6. Main relief valve completely open at _____ psi | |
| 7. Rollback _____ gpm at 1800 psi | |
| 8. Dump _____ gpm at 1800 psi | |
| 9. Lift _____ gpm at 1800 psi | |
| 10. Lower _____ gpm at 1800 psi | |
| 11. Auxiliary _____ gpm at 1800 psi | |

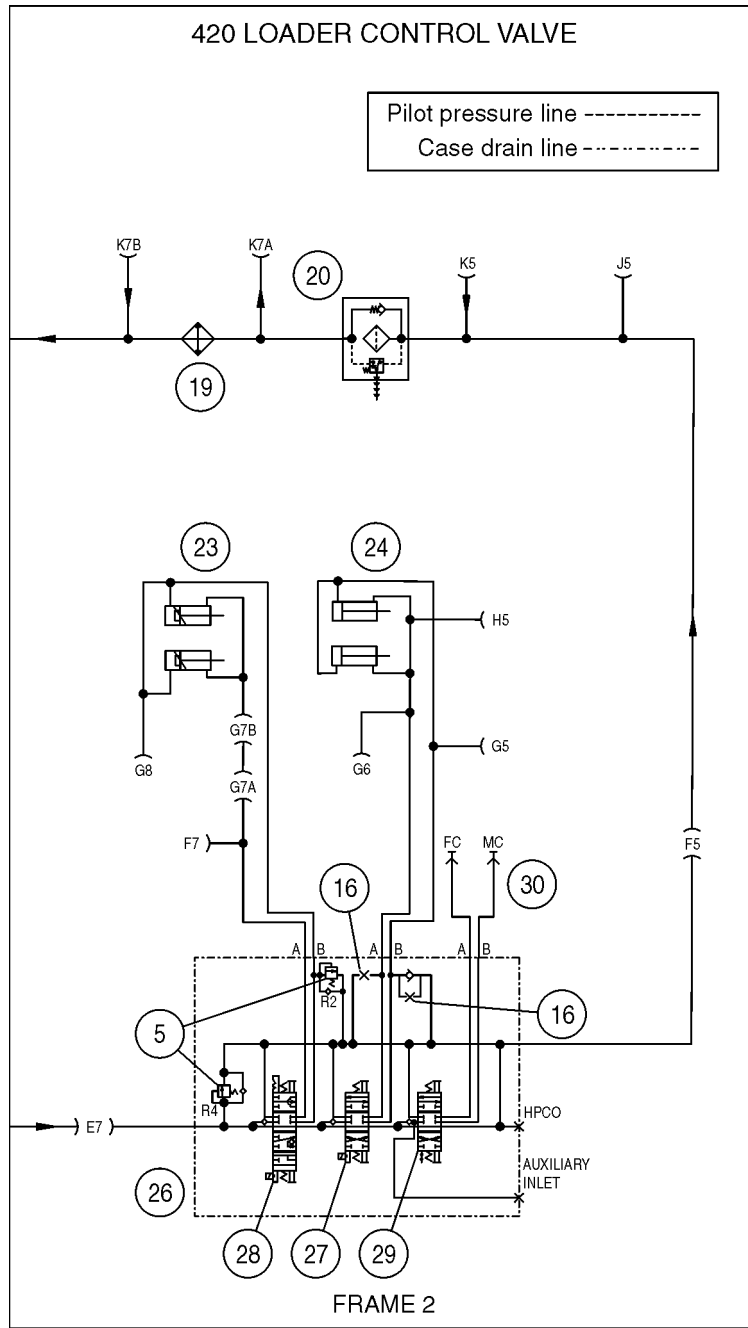

- 5. RELIEF VALVE
- 16. ORIFICE
- 19. OIL COOLER
- 20. OIL COOLER BYPASS VALVE
- 23. TILT CYLINDER
- 24. LIFT CYLINDER

- 26. LOADER CONTROL VALVE
- 27. TILT SPOOL
- 28. LIFT SPOOL
- 29. AUXILIARY SPOOL
- 30. AUXILIARY OUTLETS

420 HYDRAULIC SCHEMATIC FRAME 2

6. Disconnect the hydraulic lines from the closed ends and the rod ends of all cylinders.

NOTE: Check the hydraulic oil level frequently while you do steps 7 and 8. Have another person hold a container under the hydraulic lines while you do step 8.

7. Start and run the engine at low idle.
8. Move each control lever in both directions until clean hydraulic oil flows from each hydraulic line.
9. Stop the engine.
10. Connect the hydraulic lines to the closed ends of the cylinders.
11. Start and run the engine at low idle.
12. Move the control levers to extend the rods of all cylinders. While the rods are being extended, hydraulic oil will be pushed from the rod ends of the cylinders.
13. Stop the engine.
14. Connect the hydraulic lines to the rod ends of the cylinders.
15. Check the hydraulic oil level. Add hydraulic oil as required.

CLEANING THE HYDROSTATIC SYSTEM

The hydrostatic system is a closed loop. Any contamination in the hydrostatic system will stay in the closed loop. If a component, hose, or tube in the hydrostatic system is removed for any reason, you must clean the hydrostatic system. If any contamination is left in the closed loop, the contamination will damage the components in the hydrostatic system.

1. See Section 6002. Remove the piston pumps and motors.
2. Disassemble, clean, and inspect the piston pumps and motors. See Section 6004 for piston pumps and 6005 for the motors.
3. Clean all hoses and tubes in the hydrostatic system. See Cleaning Hoses, Tubes, and Fittings on this page.
4. Change the hydrostatic filter. See the Operators Manual for instructions.
5. See Section 6002 and install the piston pumps and motors.
6. Make sure the hydraulic system is clean so that the charge pump will not cause new contamination in the closed loop. Clean the hydraulic system as required.

CLEANING HOSES, TUBES, AND FITTINGS

It is recommended that hoses, tubes, and fittings be cleaned with a steam cleaner and dried with compressed air. Use the following procedure:

1. Fasten the parts to a rack in a position as nearly vertical as possible. This will allow the water to drain as you flush the parts.
2. Clean the exterior surfaces of the parts thoroughly.
3. Clean the interior surfaces of the parts. Use hot water with a soap solution first. Then use clean hot water to rinse.
4. Fasten the parts to the rack so that the parts can be flushed from the opposite ends. Repeat steps 2 and 3.
5. Use compressed air to dry the inside of each part. Dry the parts from both ends to make sure that all water has been removed.
6. Install caps or plugs in the ends of each hose, tube, or fitting as soon as the parts are dry. This will prevent entry of airborne contaminants. Remove the caps or plugs from a part only when the part is in position in the machine and you are ready to make the connection.

NOTE: If the steam cleaner does not have a soap injection system, spray an oil solvent into the parts. This will dissolve the oil film that holds contaminants inside the parts. Then use clean hot water to rinse.

HIGH FLOW VALVE (IF EQUIPPED)

Removal



BD05B009

1. HIGH FLOW VALVE

1. Place a shop towel under the high flow valve (1).
2. Remove the cap from the hydraulic reservoir.
3. Connect a vacuum pump to the hydraulic reservoir.
4. Start the vacuum pump.
5. Tag and disconnect all of the hydraulic connections on high flow valve (1).
6. Install a plugs in the fittings and a caps on the connections.
7. Stop the vacuum pump.
8. Disconnect the electrical harness from the high flow valve (1) solenoid valve.
9. Loosen and remove the high flow valve mounting bolts.
10. Remove the high flow valve (1) from the chassis mounting location.

Installation

1. Install the high flow valve (1) into the chassis mounting location.
2. Install and tighten the high flow valve mounting bolts.
3. Reconnect the electrical harness to the high flow valve (1) solenoid valve.
4. Start the vacuum pump.
5. Remove the plugs in the fittings and a caps from the connections.
6. Connect all of the hydraulic connections on high flow valve (1). Tighten all of the hydraulic connections.
7. Stop the vacuum pump.
8. Disconnect the vacuum pump from the hydraulic reservoir. Install the cap on the hydraulic reservoir.
9. Clean up any hydraulic fluid from equipment or floor.
10. Start and run the engine at low idle.
11. Engage the high flow hydraulics.
12. Stop the engine.
13. Check for oil leakage.
14. Check the level of the oil in the hydraulic reservoir. Add oil as required.
15. Install the cap on the hydraulic reservoir.

Installation

STEP 1

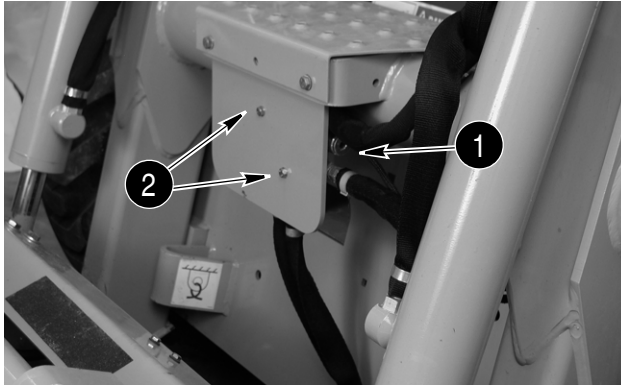

BD05B013

Install the solenoid valve into the mounting location. Install the mounting bolts (2) into the solenoid valve (1) and tighten the mounting bolts (2).

STEP 2



BD05B013

Start the vacuum pump. Remove the caps from the fittings and the plugs from the hoses. Install the hydraulic hoses to the correct fitting locations. Tighten all of the hydraulic connections. Stop the vacuum pump and remove the vacuum pump from the hydraulic reservoir. Install the cap on the hydraulic reservoir.

STEP 3

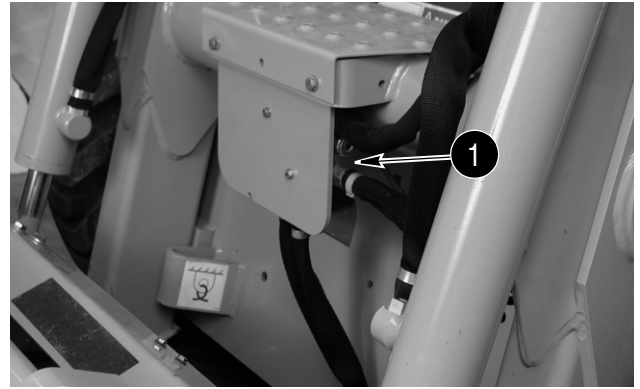

BD05B013

Connect the electrical harness to the solenoid valve (1) electrical connection.

STEP 4

Start the engine and run at low idle. Check for leaks. Stop the engine and check the hydraulic oil level in the reservoir. Add hydraulic oil as required. Install the cap on the reservoir.

GEAR (EQUIPMENT) PUMP

Disassembly

STEP 1



GD98J801

Put identification marks on the housing for use during assembly.

STEP 2



GD98J802

Loosen and remove the socket bolts and washers.

STEP 3



GD98J803

Remove the cover.

STEP 4

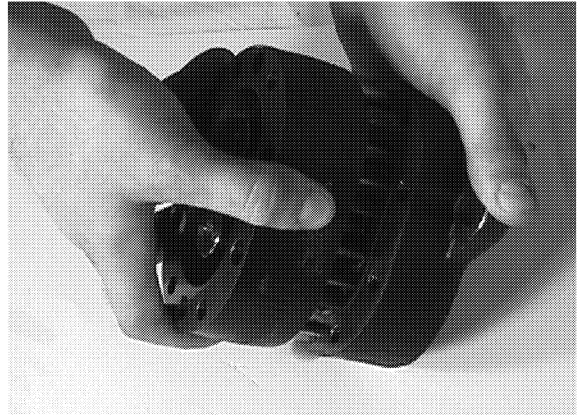

GD98J804

Remove the gear plate.

STEP 5

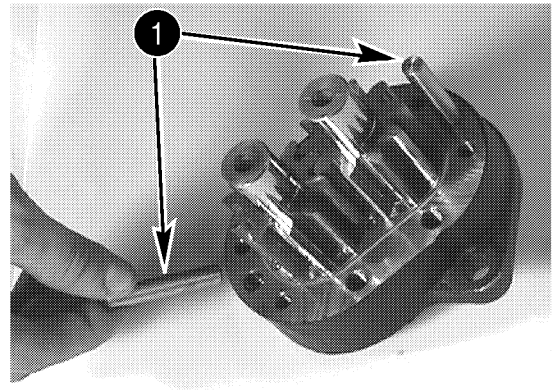

GD98J805

1. DOWEL PINS

Remove the dowel pins.

STEP 6

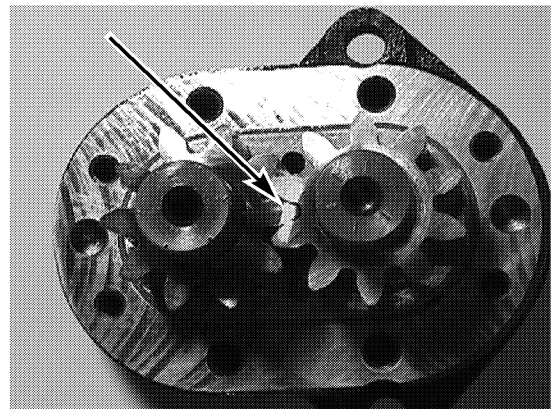

GD98J806

Mark the gear teeth, that mesh, as shown. Two teeth on one gear and one tooth on the other gear.

SPECIFICATIONS

Manufacturer	Husco
Type	3 Spool, Open Center, Series Parallel / with Power Beyond
Main Relief Pressure	20 700 ± 345 kPa (207 ± 3.5 bar) (3000 ± 50 psi)
Port Relief Pressure Settings	
Port B1 Std.	22 995 kPa 230 bar (3335 psi)
Port A2 Std. (Shut Off Plug) (Optional)	25 993 kPa 260 bar (3770 psi)
Port B2 Anti-Cavitation Valve (Optional)	22 995 kPa 230 bar (3335 psi)
Spool Functions	
Loader No.1 (Out)	Up
Loader No.1 (In)	Down
Loader No.1 (Detent)	Float
Bucket No.2 (In)	Rollback
Bucket No.2 (Out)	Dump
Auxiliary No. 3 (In).....	Auxiliary
Auxiliary No. 3 (Out).....	Auxiliary
Return Filter Bypass Pressure	345 kPa, 3.4 bar (50 psi)

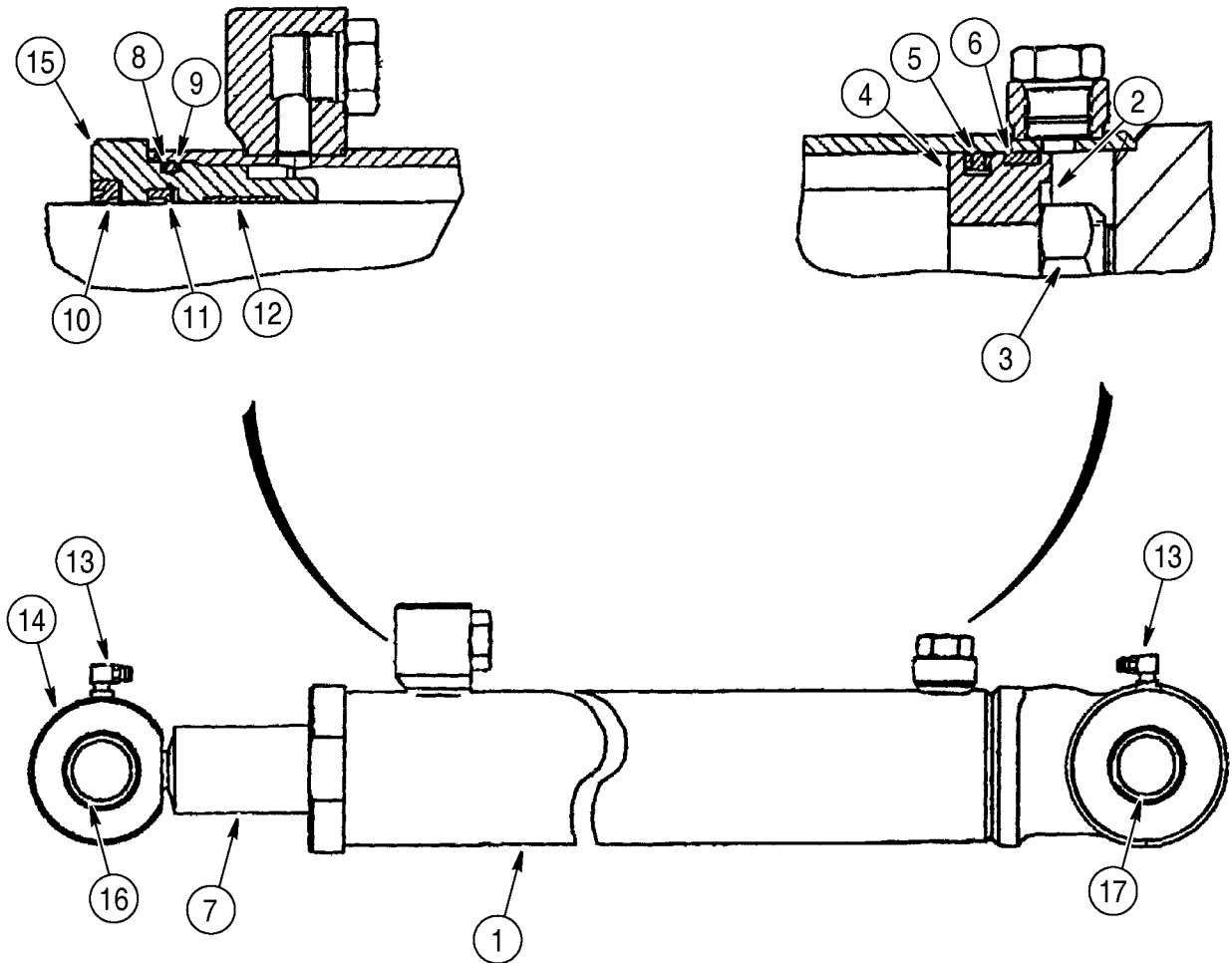

- | | | |
|--------------|----------------|--------------------|
| 1. TUBE | 7. PISTON ROD | 13. GREASE FITTING |
| 2. WASHER | 8. BACKUP RING | 14. ROD END |
| 3. LOCK NUT | 9. O-RING | 15. GLAND |
| 4. PISTON | 10. SEAL | 16. BUSHING |
| 5. SEAL | 11. SEAL | 17. BUSHING |
| 6. WEAR RING | 12. SEAL | |

CROSS SECTION VIEW OF LIFT CYLINDER

BD01J190

Section 8013

8013

ACCUMULATOR FOR RIDE CONTROL

CHARGING THE ACCUMULATOR WITH DRY NITROGEN

Check the pressure in the accumulator according to the instructions in this section. Keep the nitrogen charging kit connected to the accumulator.

1. Close (turn counterclockwise) valve (A) and open valve (B). Close valves (C and D).
2. Turn the stem out of valve (F) until the stem stops moving. Disconnect valve (F) from the valve stem on the accumulator.
3. Connect the nitrogen charging kit to a dry nitrogen tank.
4. Slowly turn valve (A) clockwise and read gauge E until the pressure is 275 to 325 psi (1897 to 2241 kPa, 19 to 23 bar). Stop turning valve (A).
5. If the pressure increases above 325 (2241 kPa, 23 bar), quickly open and close valve (D) and read gauge E. If the pressure is still too high, close valve (A) (turn counterclockwise) a small amount and quickly open and close valve (D). The pressure shown on gauge E is the charge pressure.
6. Connect valve (F) to the valve stem on the accumulator. Turn the stem into valve F until the stem stops moving and open valve D to charge the accumulator.
7. After the accumulator stops charging, turn the stem out of valve (F) until the stem stops moving.
8. Close valve (B) and disconnect the nitrogen charging kit from the valve stem in the accumulator.
9. Install the cap on the valve stem. Install the guard and cap screws.

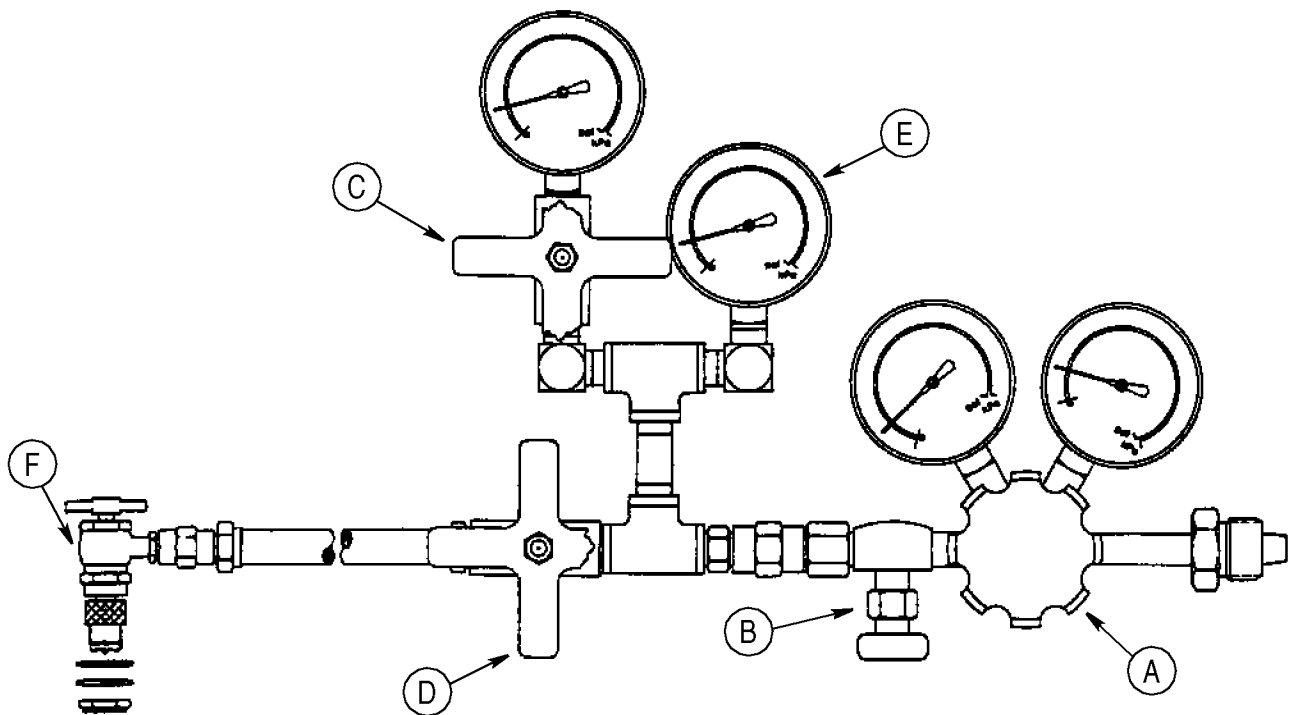

94L95

THROTTLE CONTROL LEVER ADJUSTMENT

Hand Throttle Lever Tension Adjustment

1. The tension adjusting nut (2) for the throttle lever (1) is to compress the rubber washer (10) to cause a resistance to hold the throttle lever in the position selected.
2. The tension adjusting nut (2) is not to be so tight the throttle lever is difficult to move.
3. Remove any attachments from the loader lift arms.
4. Refer to the operators manual for the correct procedure and tilt the ROPS for service.
5. The throttle control lever (1) may be in any working position during the adjustment procedure.
6. Measure the resistance that is required to move the throttle control lever (1) from the low idle to high idle position. The effort required to move the throttle control lever (1) should be measured at the top of the throttle control lever (1).
7. Loosen the jam nut (8).
8. Tighten or loosen the nut (2) until the force required to move the throttle control lever (1) is 50 ± 10 N.
9. When the effort required to move the throttle control lever (1) is correct tighten the jam nut (8) against the nut (2).
10. Lower the ROPS to the operating position.

Hand Throttle Adjustment (With Foot Throttle Option)

The adjustment procedure for the hand throttle with the foot throttle option is very similar to the procedure without the foot throttle.

1. The tension adjusting nut (2) for the throttle lever (1) is to compress the rubber washer (10) to cause a resistance to hold the throttle lever in the position selected.
2. The tension adjusting nut (2) is not to be so tight the throttle lever is difficult to move.
3. Remove any attachments from the loader lift arms.
4. Refer to the operators manual for the correct procedure and tilt the ROPS for service.
5. Disconnect the foot throttle linkage from the linkage controller so that the only input to the controller is from the hand throttle.
6. The throttle control lever (1) may be in any working position during the adjustment procedure.
7. Measure the resistance that is required to move the throttle control lever (1) from the low idle to high idle position. The effort required to move the throttle control lever (1) should be measured at the top of the throttle control lever (1).
8. Loosen the jam nut (8).
9. Tighten or loosen the nut (2) until the force required to move the throttle control lever (1) is 50 ± 10 N.
10. When the effort required to move the throttle control lever (1) is correct tighten the jam nut (8) against the nut (2).
11. Lower the ROPS to the operating position.
12. Depress and release the foot pedal to confirm proper operation.

Section 9002

9002

LOADER

ATTACHMENT COUPLER (MECHANICAL)

Disassembly

NOTE: Refer to illustration on page 4.

1. Loosen and remove the nut (19), bolt (16), washers (17 and 20), and spacer (18) from the left and the right lower pins (21) on the coupler frame (1).
2. Use acceptable tools and remove the left and the right lower pins (21) from the coupler frame (1).
3. Loosen and remove the nut (19), bolt (16), washers (17 and 20), and spacer (18) from the left and right upper pins (23) of the coupler frame (1).
4. Use acceptable tools and remove the left and right upper pins (23) from the coupler frame (1).
5. Remove the coupler frame (1) from the loader arms.
6. Place the coupler frame (1) on a work bench.
7. Remove the cotter pin (12) from pin (13) and latch pin (14).
8. Remove the retaining ring (15) from the right handle pivot pin (10). Remove the pivot pin (10) from the frame (1).
9. Lift the right handle (3) until the pin (13) disengages the latch pin (14). Remove the right handle (3) from the coupler frame (1). Remove the latch pin (14) from the coupler frame (1).
10. Place the right handle (3) in a vise with soft jaws.
11. Prevent the pin (13) from turning. Loosen and remove the bolt (6) from the pin (13). Remove the bolt (6), pin (13), spring (9), spring guide (8), and pin (7) from the right handle (3).
12. Repeat steps 7 through 11 for the left handle (2).

Inspection

1. Inspect the coupler frame (1) to be sure it is free of cracks, corrosion, rust or any other damage. Use new parts as required.
2. Inspect the upper pins (23) and the lower pins (21) for wear, cracks, corrosion or any other damage. Use new parts as required.
3. Inspect the latch pins (14) for wear and damage. Use new parts as required.
4. Inspect the bolt (6), pin (13), spring (9), spring guide (8), and pin (7) for wear and damage. Use new parts as required.

5. Inspect the left handle (2) and the right handle (3) for wear and damage. Use new parts as required.

Assembly

1. Place the right handle (3) in a vise with soft jaws.
2. Install the pin (7) into the right handle (3).
3. Place the bolt (6) into the pin (7) and install the spring guide (8), spring (9) and pin (13) on the bolt (6).
4. Prevent pin (13) from turning and tighten the bolt (6).
5. Install the latch pin (14) into the coupler frame (1). Be sure the tapered side of the latch pin (14) faces the coupler frame (1).
6. Install the right handle (3) onto the coupler frame (1). Install the pivot pin (10) into the right handle (3) and coupler frame (1).
7. Install the retaining ring (15) onto the pivot pin (10). Lift the handle (3) until the pin (13) will engage the latch pin (14).
8. Install the cotter pin (12) through the latch pin (14) and pin (13).
9. Repeat steps 1 through 8 for the left handle (2).
10. Install the coupler frame (1) onto the loader arms.
11. Install the left and right upper pins (23) into the coupler frame (1).
12. Install the bolts (16), spacers (18), washers (17 and 20), and nuts (19) for the left and right upper pins (23). Tighten the nuts (19).
13. Install the left and right lower pins (21) into the coupler frame (1).
14. Install the bolts (16), spacers (18), washers (17 and 20), and nuts (19) for the left and right lower pins (21). Tighten the nuts (19).

POSSIBLE DAMAGE TO THE ROPS CANOPY

If the machine has been rolled over or the ROPS canopy has been damaged (such as hitting an overhead object during transport), the ROPS canopy shall be replaced in order to maintain maximum protection.

After an accident, check for damage to the ROPS canopy, the operators seat, the seat belt, all accessories, and wiring in the ROPS canopy. Before operating the machine again, all damaged parts must be replaced.

IMPORTANT: *Do not weld or try to straighten a ROPS canopy.*

MAINTENANCE AND INSPECTION OF THE ROPS CANOPY



WARNING: *Improper ROPS inspection or maintenance can cause injury or death. Do the recommended ROPS inspection shown in this manual. If you must replace the ROPS, ROPS parts, or ROPS mounting hardware, use only the replacement parts shown in the Case parts catalog for this machine.*

SM029



WARNING: *Securely fasten your seat belt. Your machine is equipped with a ROPS cab, ROPS canopy or ROPS frame for your protection. The seat belt can help insure your safety if it is used and maintained. Never wear a seat belt loosely or with slack in the belt system. Never wear the belt in a twisted condition or pinched between the seat structural members.*

M437



WARNING: *Do not modify ROPS in any manner. Unauthorized modifications such as welding, drilling, cutting or adding attachments can weaken the structure and reduce protection. Replace ROPS if subjected to roll-over or damage. Do not attempt to repair.*

SM026

After the first 20 hours of operation and after every 500 hours of operation, do the following:

1. Check the operators seat and the mounting parts for the seat belt. Torque the seat belt mounting bolts to 52 to 61 Nm (38 to 45 pound-feet). Use new parts as required.
2. Check for cracks, rust, or holes in the ROPS and ROPS parts. Age, weather and accidents can cause damage to the ROPS and ROPS parts. If you have any doubt about the ROPS system, see your Case dealer. Use new parts as required.



WARNING: *If you operate this machine without a ROPS and the machine rolls over, you can be injured or killed. Remove the ROPS only for service or replacement. Do not operate this machine with the ROPS removed.*

SM027



WARNING: *Adding additional weight (attachments, etc.) to the machine can cause injury or death. Do not exceed the gross weight printed on the ROPS label.*

SM028

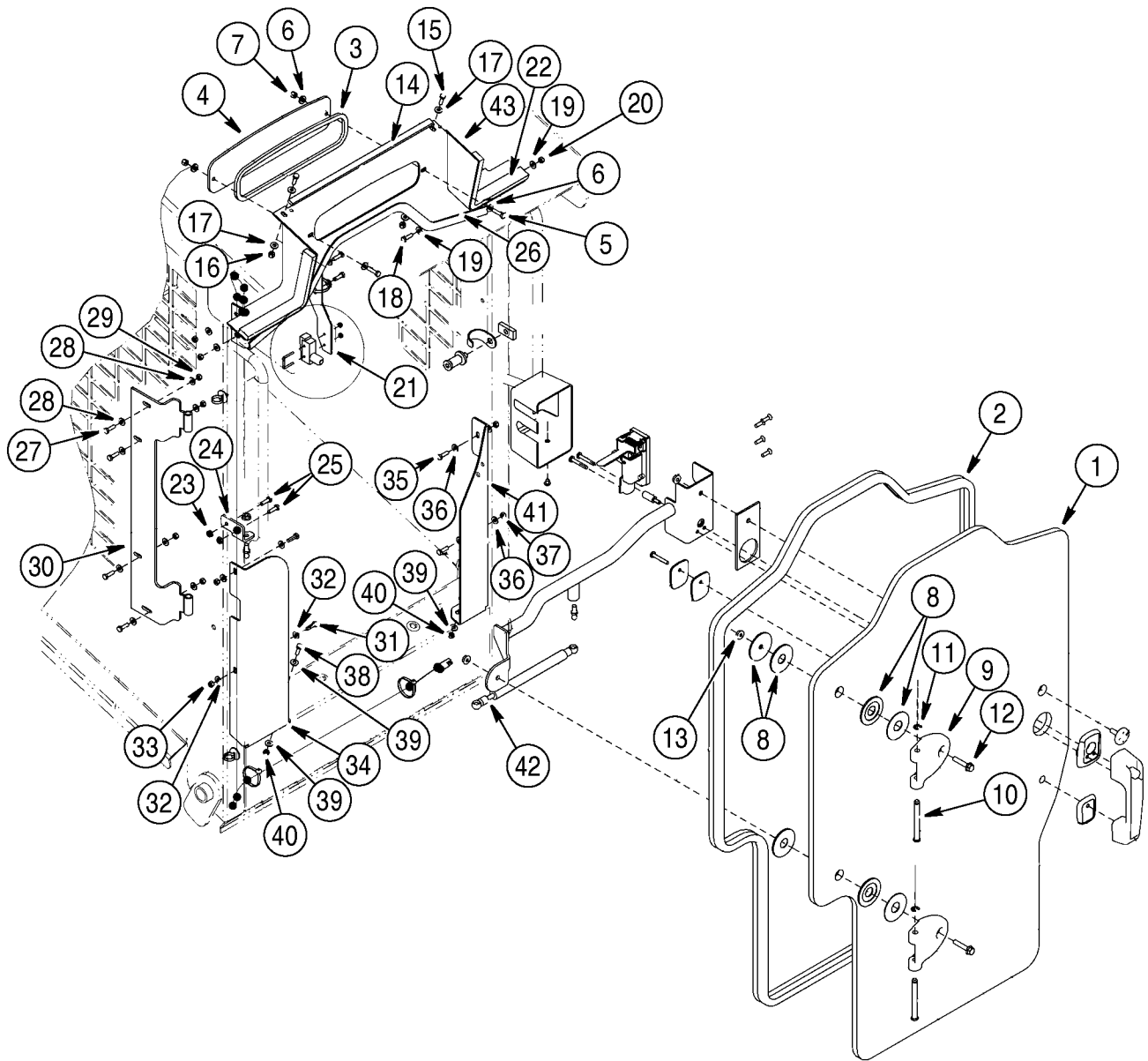

BS01H288

- | | | | |
|--------------------|-----------------|----------------|------------------------|
| 1. FRONT DOOR | 12. FLANGE BOLT | 23. FLANGE NUT | 34. BRACKET |
| 2. SEAL | 13. FLANGE NUT | 24. BRACKET | 35. BOLT |
| 3. SEAL | 14. SEAL | 25. BOLT | 36. WASHER |
| 4. WINDOW | 15. BOLT | 26. SEAL | 37. LOCK NUT |
| 5. BOLT | 16. LOCK NUT | 27. BOLT | 38. BOLT |
| 6. WASHER | 17. WASHER | 28. WASHER | 39. WASHER |
| 7. LOCK NUT | 18. BOLT | 29. LOCK NUT | 40. LOCK NUT |
| 8. WASHER | 19. WASHER | 30. BRACKET | 41. BRACKET |
| 9. HINGE | 20. LOCK NUT | 31. BOLT | 42. GAS STRUT CYLINDER |
| 10. PIN | 21. BRACKET | 32. WASHER | 43. BRACKET |
| 11. RETAINING RING | 22. SEAL | 33. LOCK NUT | |

ROPS CANOPY - FRONT DOOR (IF EQUIPPED)

CLICK HERE TO **DOWNLOAD** THE COMPLETE MANUAL

- Thank you very much for reading the preview of the manual.
- You can download the complete manual from: www.heydownloads.com by clicking the link below



- Please note: If there is no response to CLICKING the link, please download this PDF first and then click on it.

CLICK HERE TO **DOWNLOAD** THE COMPLETE MANUAL