

1. Trim along dashed line.
2. Slide into pocket on Binder Spine.

TYPE 1-4

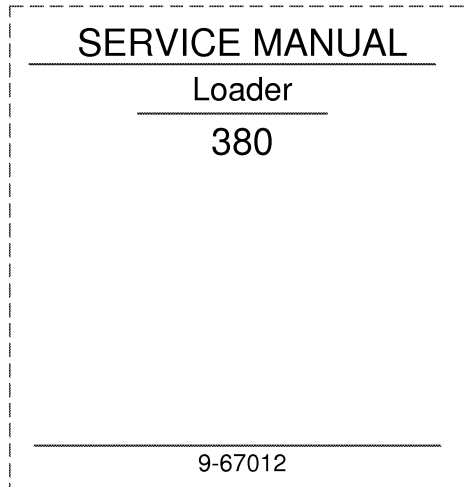

1. Trim along dashed line.
2. Slide into pocket on Binder Spine.

TYPE 1-4

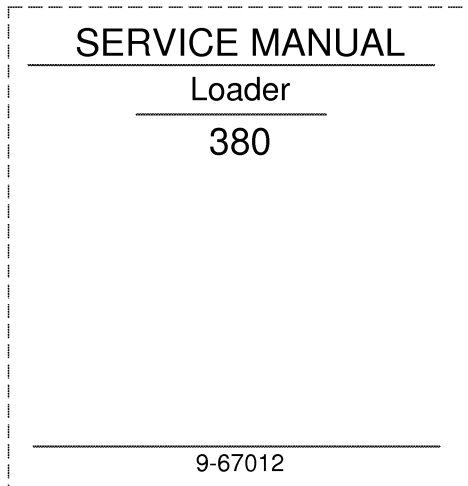

1. Trim along dashed line.
2. Slide into pocket on Binder Spine.

TYPE 1-4

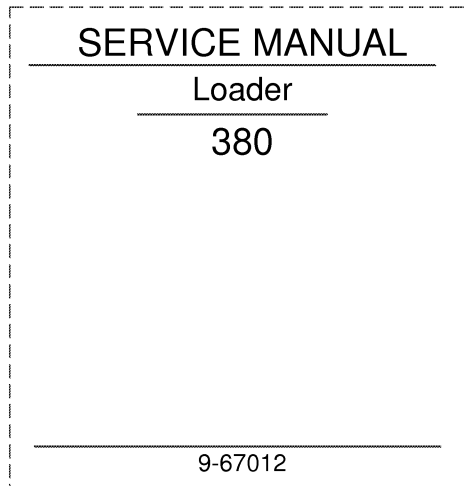

1. Trim along dashed line.
2. Slide into pocket on Binder Spine.

TYPE 1-4

CLICK HERE TO **DOWNLOAD** THE COMPLETE MANUAL

- Thank you very much for reading the preview of the manual.
- You can download the complete manual from: www.heydownloads.com by clicking the link below



- Please note: If there is no response to CLICKING the link, please download this PDF first and then click on it.

CLICK HERE TO **DOWNLOAD** THE COMPLETE MANUAL

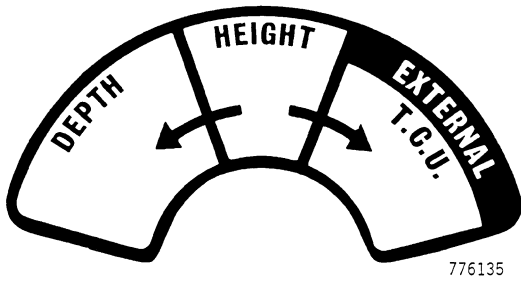

Figure 20 - K915179, see Figure 19 for location

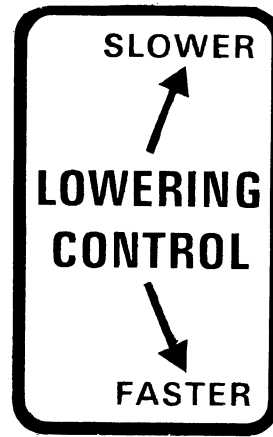
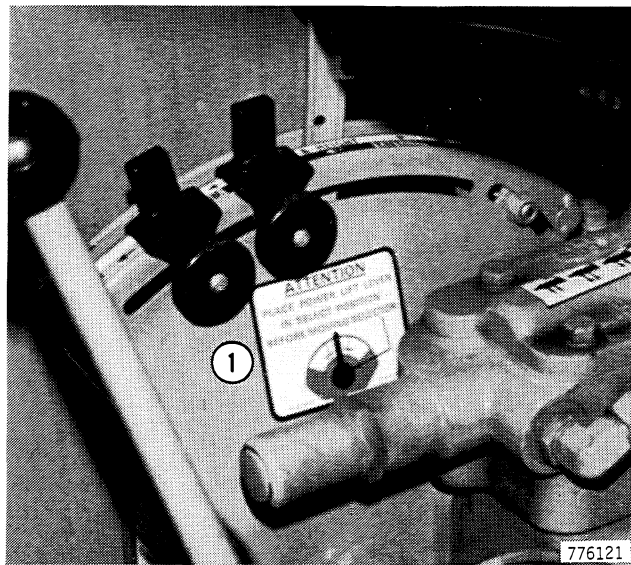

Figure 23 - K917242, see Figure 22 for location



750524

Figure 21 - K915178, see Figure 19 for location



1. K915177

Figure 24

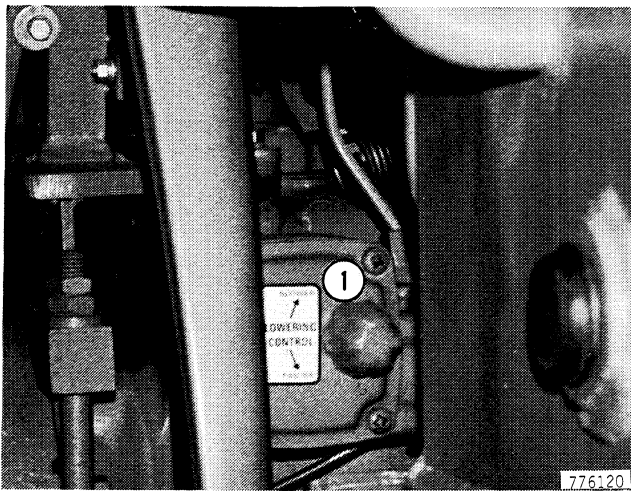

1. K917242, see Figure 23

Figure 22

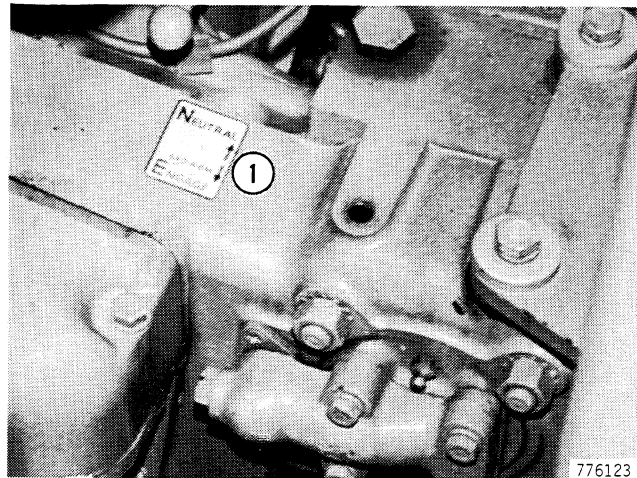

1. K923336

Figure 25

INTERVAL	SERVICE	INSTRUCTIONS
Every 2000 hours or Yearly, whichever occurs first	Drain, flush, and refill cooling system.	
As required	<p>Replace or clean air filter element.</p> <p>Replace transmission filter element when indicated by warning light.</p> <p>Check engine oil level when indicated by warning light.</p> <p>Service electrical system when indicated by warning light.</p> <p>After removing and installing a wheel, check cap screw or nut torque every two hours until stable.</p>	<p>Section 2051</p> <p>Section 4002</p> <p>Section 6429</p>

ENGINE HARD TO START OR WILL NOT START

Smoke From Exhaust

1. **Slow Cranking Speed:**

Starter must crank engine 200 to 300 rpm (r/min) in order to ignite the diesel fuel. Check engine speed while cranking. If cranking is slow, check starter amperage draw to help determine the following problem areas: batteries, cables, solenoid, and starting motor.

Slow cranking speed can be caused by the following internal and external engine defects: scuffing and scoring of pistons and cylinder walls, improper crankshaft or camshaft end play defective rod or crank bearing, oil pump, water pump and hydraulic pump.
2. **Fuel Shut-Off Not Open Completely:**

Improper cable adjustment, damaged cable or cable slipping in clamps will not allow the fuel shut-off to open completely. Check lever to be sure it is opening completely. A partially opened lever limits the amount of fuel to the injection pump and results in low engine horsepower.
3. **Low Compression:**

Low compression on any cylinder makes the engine hard to start and rough running. Make a compression test on the engine.
4. **Air Filter Plugged:**

A dirty filter will cause rich fuel mixtures and low engine power. Service air filter if required.
5. **Fuel Injection Nozzles Malfunctioning:**

Low pressure, improper spray pattern, or plugged spray orifice will affect proper combustion in engine cylinders. Remove and test the fuel injection nozzles.
6. **Engine Timing Incorrect:**

Combustion will not occur in the cylinder at the correct moment if the engine timing is incorrect. This can cause pre-combustion and serious damage to the engine. Check for proper engine timing.
7. **Piston Rings Worn:**

As piston rings become worn, they lose tension and ability to seal and wipe lubricating oil off cylinder walls. Take a compression test to determine piston ring condition. If readings are low, squirt a small amount of oil into the cylinder and retest. If compression comes up because the oil helps the rings seal, it will be necessary to install new piston rings and possibly new pistons.
8. **Valve Push Rods Bent:**

Bent push rods will affect valve operation and not allow cylinders to get a full charge of fuel and air, or not exhaust properly. This can usually be distinguished by excessive valve tappet noise. Remove cylinder cover and check for bent push rods.
9. **Clogged Fuel Filter:**

Check and service fuel filters.
10. **Fuel Injection Nozzle Not Seated In Head:**

A nozzle that is not seated in the cylinder head will leak air and not allow enough compression to fire the injected fuel. Check for damaged nozzle gasket or seals, loose nozzle, or broken stud.
11. **Tune-up Specifications Wrong:**

Check for correct specifications when performing engine tune-up.
12. **Piston and Cylinder Walls Scuffed and Scored:**

Scuffing starts as a very small surface disturbance of torn out metal particles. This helps break down lubrication which increases heat and spreads the scuffing to adjacent areas. Scuffing and scoring are caused by malfunctioning of the lubrication system or cooling system, incorrect timing, pre-combustion, lugging or overloading, improperly fitting parts and improper break-in procedure. Remove piston assemblies and inspect.
13. **Cylinder Head Gasket Blown:**

A blown cylinder head gasket will cause one or more cylinders to lose power and cause an engine to miss. Compression leaking into the water system can also cause the cooling system pressure to rise and blow engine coolant out the radiator overflow. Take a compression test to help determine a defective head gasket, or remove radiator cap, run engine and check for gas bubbles rising in coolant at radiator opening.

6. **Excessive Oil In Rocker Arm Compartment:**

Excessive oil in rocker arm compartments can be caused by wrong rocker arms, rocker arm shafts indexed wrong, worn rocker arm busings, high oil pressure and poor oil drainage back to crankcase. Remove cylinder cover and check for above problems.

7. **Engine Speed Too High:**

Running at speeds higher than the engine is designed for will aggravate all oil consumption areas such as oil pressure, oil flow, throwoff onto cylinder walls and oil in rocker arm compartments. Check engine speeds and set according to specifications.

8. **Connecting Rod Bearings Worn:**

Worn rod bearings cause more than normal throw-off of lubricating oil to cylinder pistons and liners. This excess oil is sometimes more than worn piston oil rings can control. The oil then passes the rings and on into the combustion chamber. Remove the engine oil pan and check rod bearings for wear using plasti-gauge. A worn rod bearing can cause the engine to knock and have low oil pressure.

9. **Engine Oil Too Light:**

Using engine oil that is too light will aggravate all oil consumption areas because of additional oil flow and leakage of the lighter oil. Light engine oil will give lower than normal oil pressure readings. Check for proper weight oil and change oil if required.

10. **Piston Rings Not Seated:**

Most piston rings will seat in the first few hours of operation. If engine continues to use oil, it is usually a problem other than piston rings. Items that can cause rings not to seat are: out-of-round cylinder,

improper deglazing of cylinders, rings installed wrong or improper break-in procedure. Do not add abrasives to intake system to seat rings. If it is suspected that rings are not seated, tear down engine and inspect.

11. **Engine Oil Pressure Too High:**

High oil pressure will cause additional oil throw-off from connecting rod bearings for lubrication of cylinder walls. This additional oil can be more oil than worn piston rings can control. High oil pressure will cause excessive oil in all areas and can cause oil consumption. Remove engine oil pan and adjust oil pump relief valve.

12. **Piston Ring Installation Faulty or Broken Rings:**

At times, piston rings are installed wrong, upside down or wrong size. Be sure to carefully read instructions before installing piston rings. Damaged rings can cause scoring of the cylinder walls and cause the engine to use oil.

13. **Cylinder Head Gasket Damaged:**

A cylinder head gasket can be damaged or installed wrong allowing lubricating oil to enter the combustion chamber and to be burned in the engine. Remove cylinder head and check gasket if all other tests check out all right.

14. **Oil Leakage Past Valve Guides and Valve:**

Excessive valve stem-to-guide clearance can cause high oil consumption. A heavy carbon build-up on valve stems and face is the result of excessive oil leakage past valve guides, also a noticeable loss of engine power can result.

Fuel Filter Removal

1. Disconnect the injector return tube from the fuel filter, Figure 20.

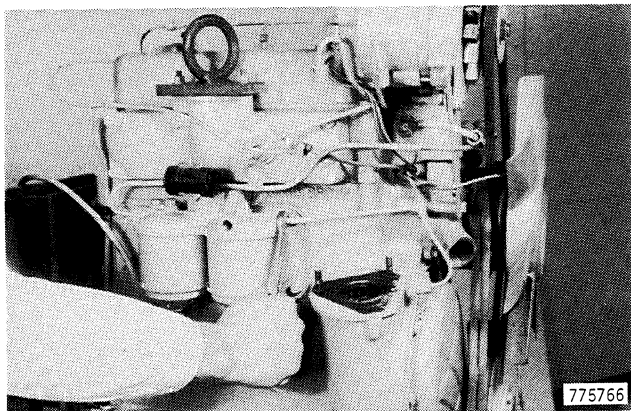

Figure 20

2. Disconnect the tube out of the fuel filter, Figure 21.

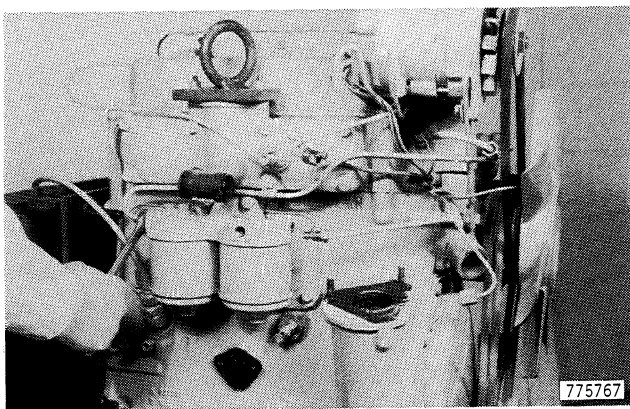

Figure 21

3. Remove the cap screw that holds the clamp on the fuel supply tube, Figure 22.

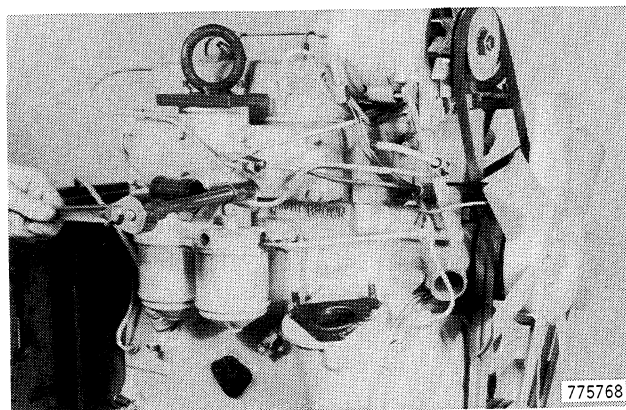

Figure 22

4. Remove the fuel supply tube, Figure 23.

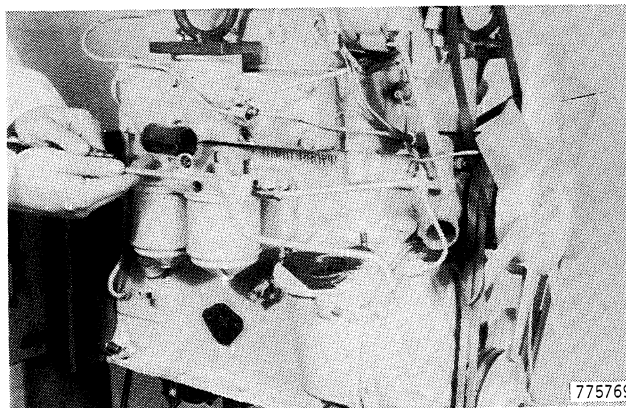

Figure 23

5. Remove the cap screws from the fuel filter, Figure 24.

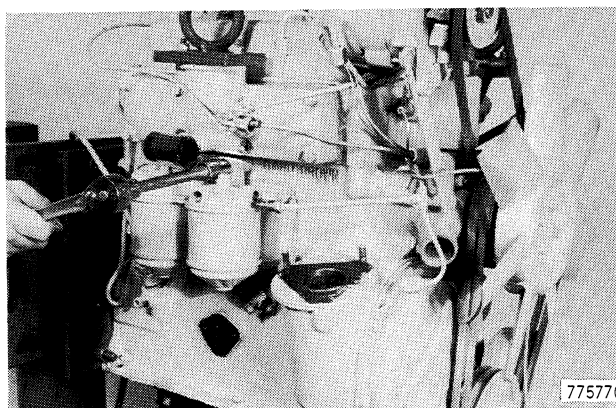

Figure 24

6. Remove the fuel filter, Figure 25. Do not lose the spacers behind the filter.

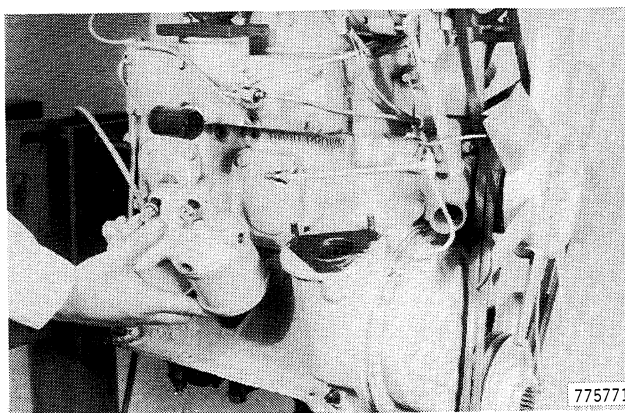
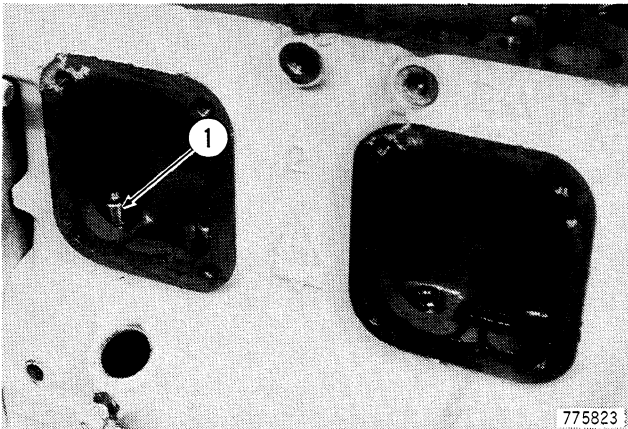

Figure 25

12. Lift lifters up and put a 1/2" (12 mm) diameter O-ring over tappets to hold them up, Figure 77.



1. O-ring

Figure 77

13. Pull cam shaft from cylinder block, Figure 78.

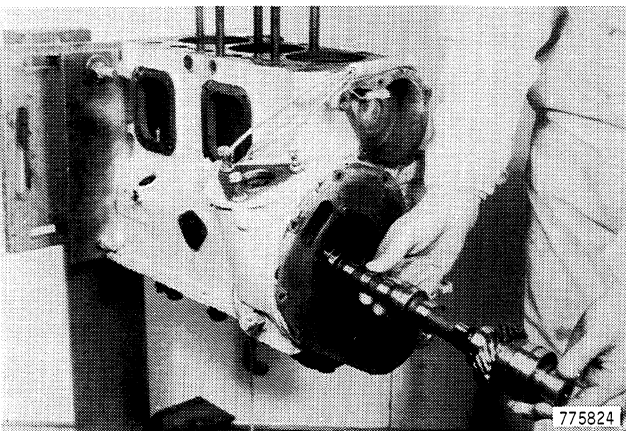

Figure 78

Oil Pump and Fuel Injection Pump Drive

Removal

1. Pull oil pump and fuel injection pump drive from the engine block, Figure 79.

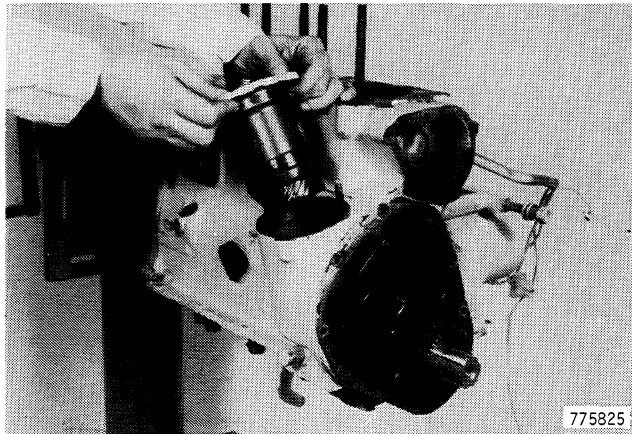

Figure 79

Disassembly and Assembly

1. Remove the snap ring from the drive gear, Figure 80.

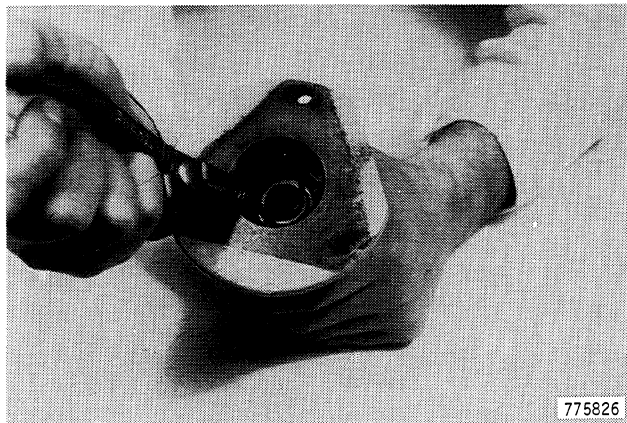

Figure 80

- 2. Install the valve spring on the valve stem, Figure 124. The springs color coded yellow are the exhaust valve springs.

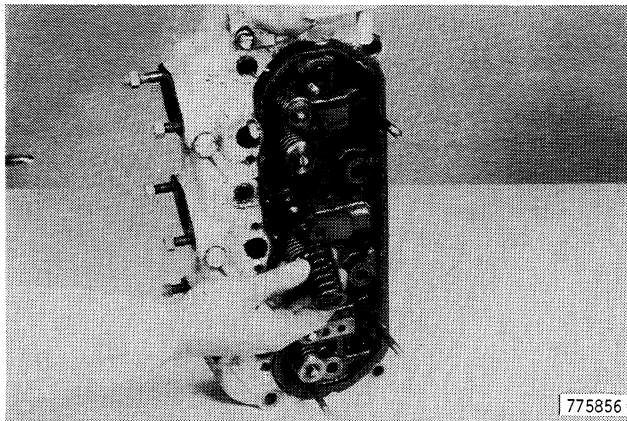

Figure 124

- 3. Install the spring cup on the valve stem, Figure 125.

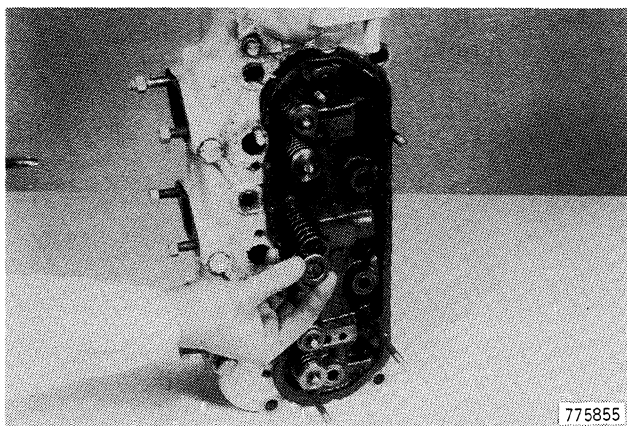

Figure 125

- 4. Install the valve spring compressing tool and compress the valve spring, Figure 126.

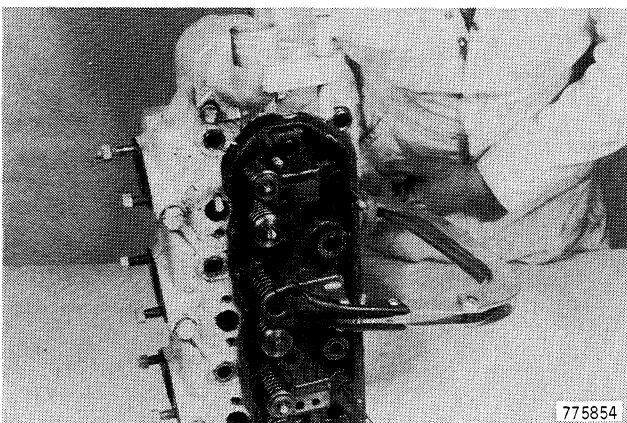

Figure 126

- 5. Install collar on valve stem, Figure 127.

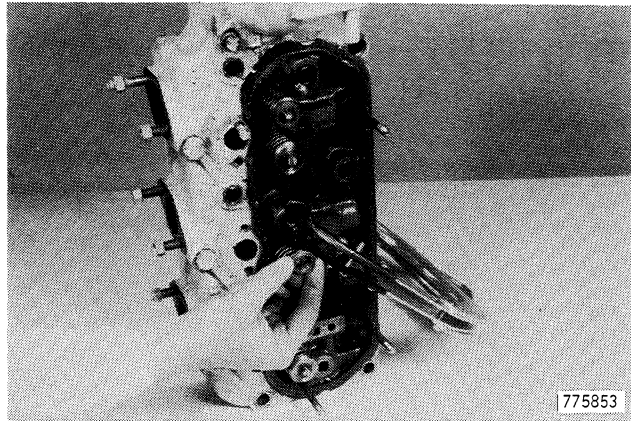

Figure 127

- 6. Install valve keepers, Figure 128.

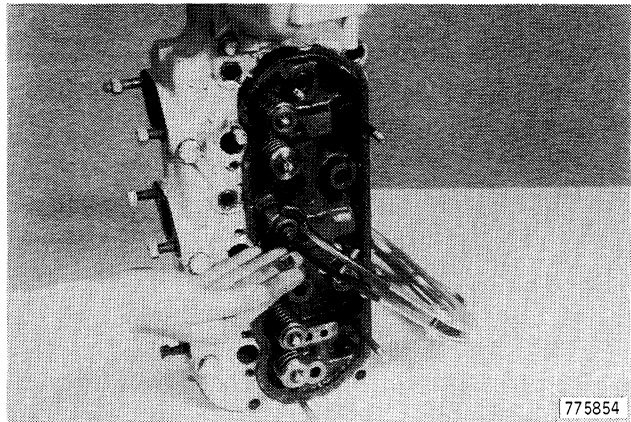

Figure 128

- 7. Release the valve spring compressor tool, Figure 129.

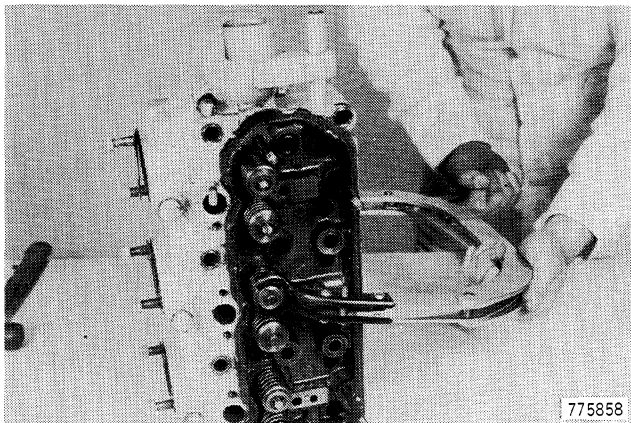

Figure 129

- Turn the engine crankshaft slowly until the front cylinder inlet valve closes. Install the engine oil pump and injection pump drive. The engine oil pump and injection pump drive must be timed by starting the teeth meshing into the camshaft at a 4 o'clock position, Figure 169. As the drive is pushed fully into the engine block, the master spline will be between the 6 o'clock position and the 7 o'clock position.

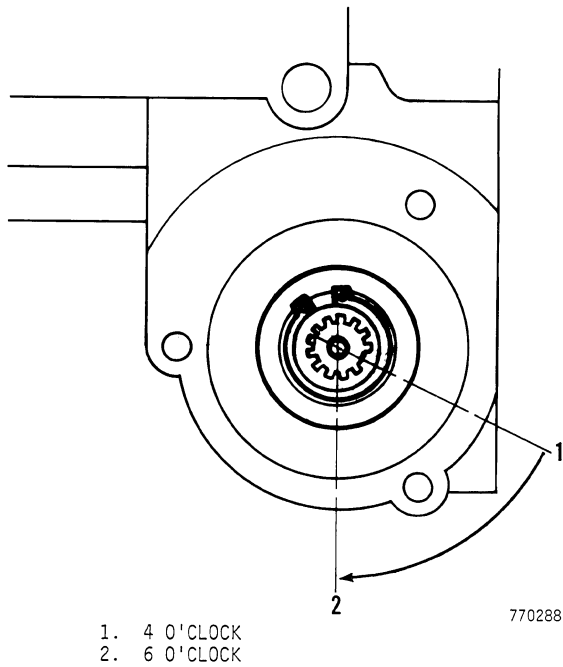

Figure 169

- Clean old gasket material from valve cover and install a new gasket. Install valve cover, Figure 170.

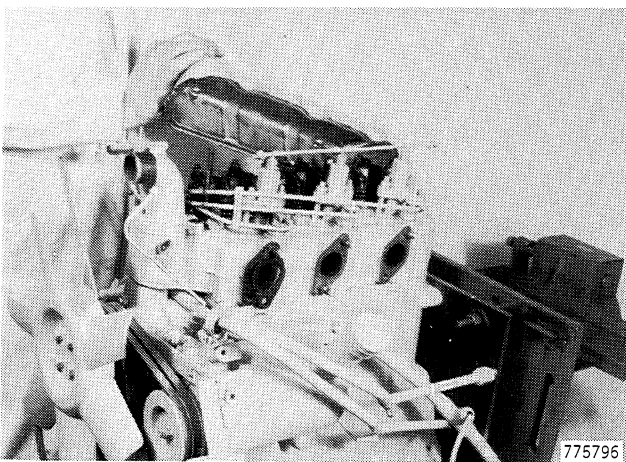

Figure 170

- Install new copper washers on valve cover studs. Install domed nuts on valve cover studs, Figure 171.

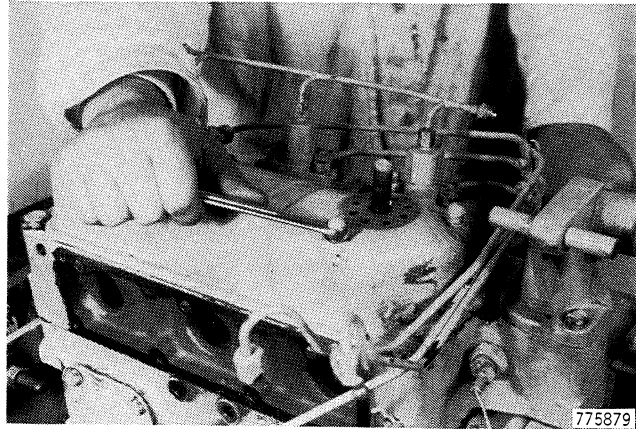

Figure 171

- Install injector return tube between cylinder head and engine block, Figure 172. Tighten fitting.

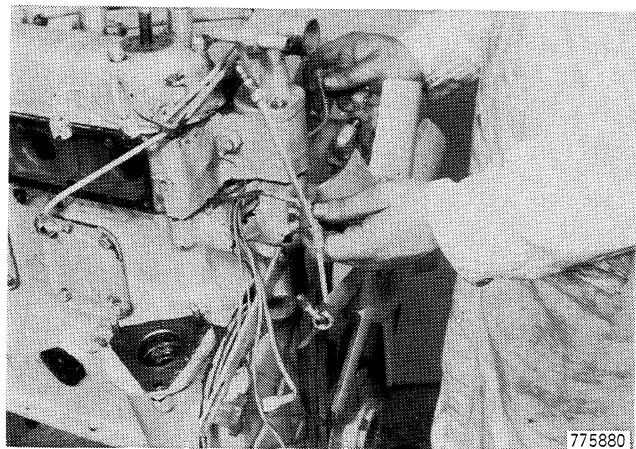

Figure 172

- Install the cap screw that retains the injector return tube clamp, Figure 173.

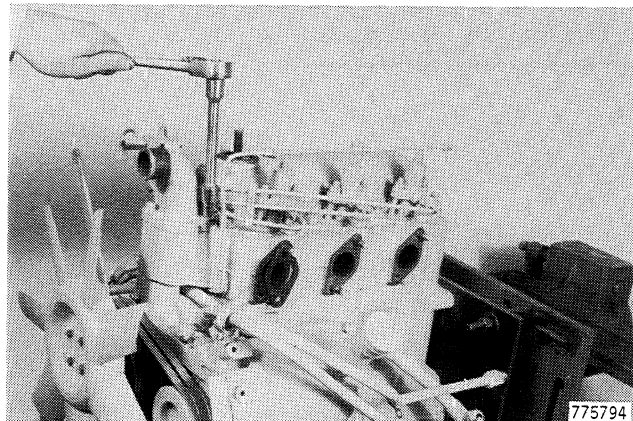

Figure 173

TABLE OF CONTENTS

Specifications	2025-3
Special Tools	2025-4
Engine Disassembly	2025-5
Oil Pump	2025-5
Removal	2025-5
Disassembly	2025-6
Inspection	2025-7
Assembly	2025-8
Suction Tube Removal and Installation	2025-9
Relief Valve Removal and Installation	2025-9
Installation	2025-10
Piston Removal	2025-11
Crankshaft Removal	2025-12
Piston Disassembly	2025-13
Piston Inspection	2025-14
Piston Assembly	2025-15
Engine Block Assembly	2025-15
Crankshaft Installation	2025-15
Piston Installation	2025-17

4. Remove the self locking nuts from the connecting rod bearing cap, Figure 40.

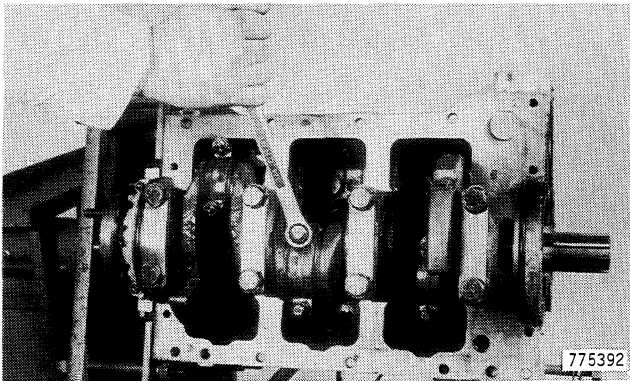

Figure 40

5. Make sure connecting rods and bearing caps are marked so they can be installed in the same position. Remove the bearing caps, Figure 41. If the connecting rod bearing inserts are going to be used again, keep them in order so they can be installed in their original location.

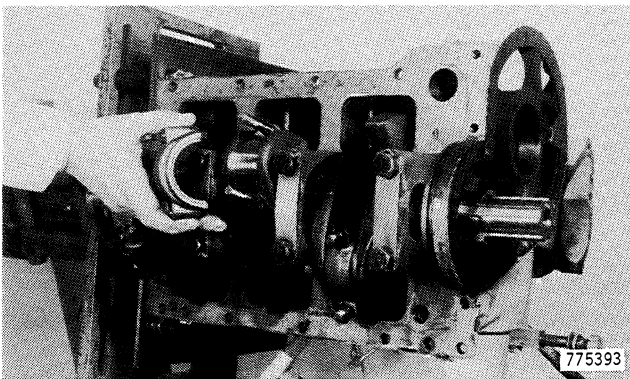

Figure 41

6. Use a wooden block or the handle of a hammer and hit the connecting rod cap bolts, Figure 42. Be careful not to damage the insert bearing. Remove the piston and connecting rod.

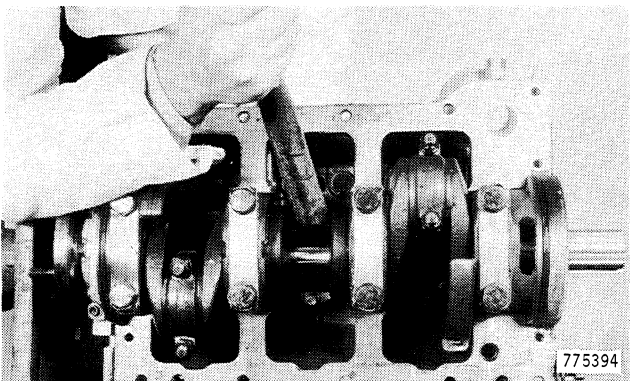

Figure 42

Crankshaft Removal

1. Remove the Allen head cap screws from the seal retainer plate, Figure 43.

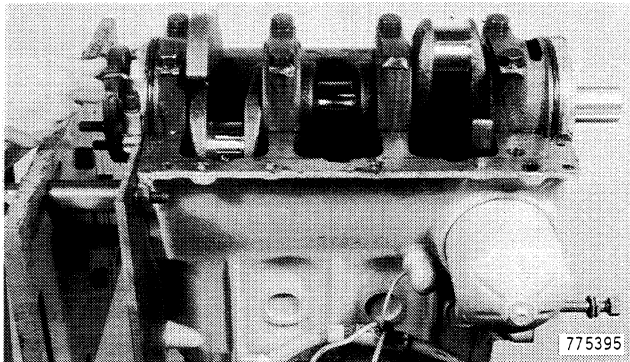

Figure 43

2. Bend the tabs on the tab washers away from the heads of the cap screws on the main bearing caps, Figure 44.

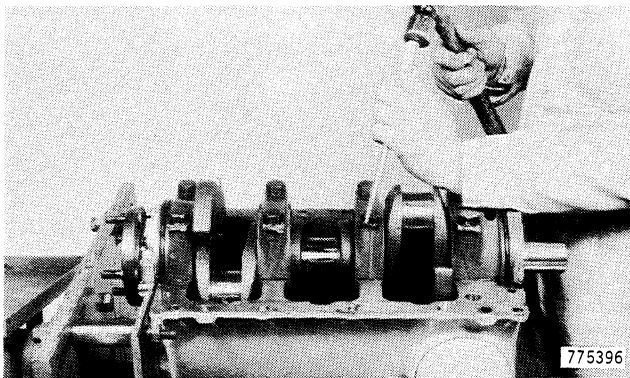

Figure 44

3. Remove the cap screws and tab washer from the main bearing caps, Figure 45.

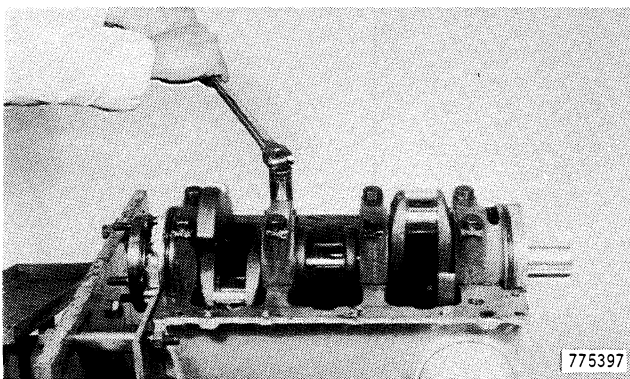

Figure 45

TABLE OF CONTENTS

Special Tools	2050-3
Engine Removal	2050-4
Engine Installation	2050-20
Venting the Fuel System	2050-34
Radiator Removal	2050-35
Radiator Installation	2050-38

- 52. Remove the two outer cap screws that hold the front and rear housings together, Figure 49. Remove the four cap screws from underneath the housing. As the two outside cap screws are removed the step will fall down.

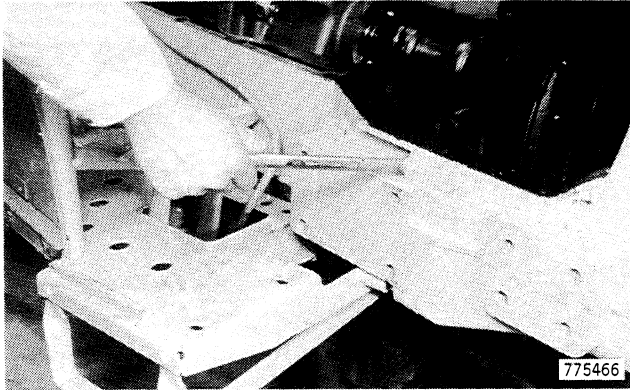

Figure 49

- 55. Adjust the jack under the clutch housing and pry the two housings apart, Figure 52.

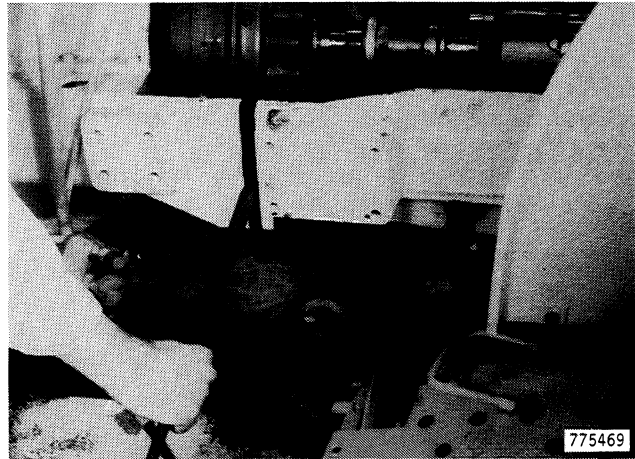

Figure 52

- 53. Remove the four inner cap screws that hold the front and rear housings together, Figure 50.

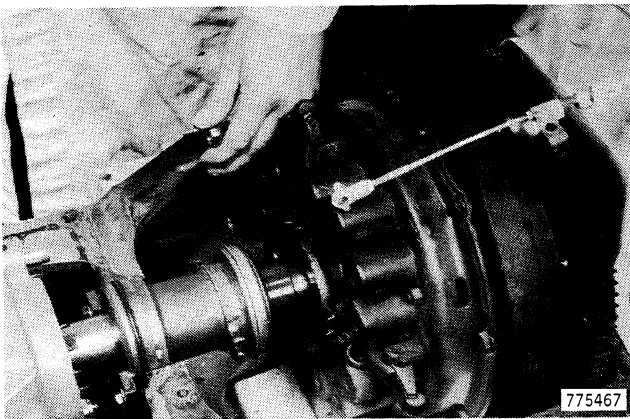

Figure 50

- 56. Push the front housing away from the rear housing, Figure 53. Block front housing in position.

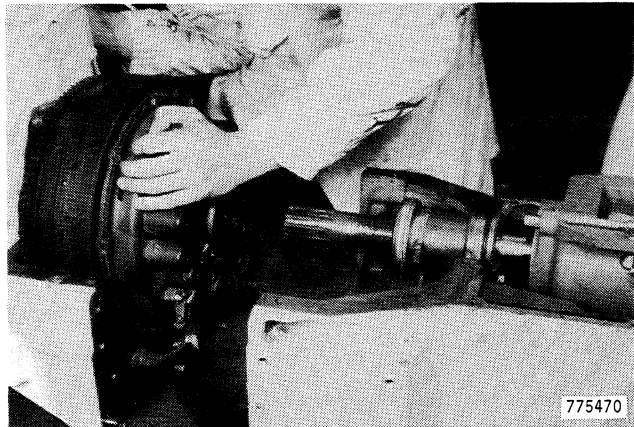

Figure 53

- 54. Disconnect the hoses at the steering cylinder, Figure 51. Put a plug and cap on the hoses and steering cylinder tubes.

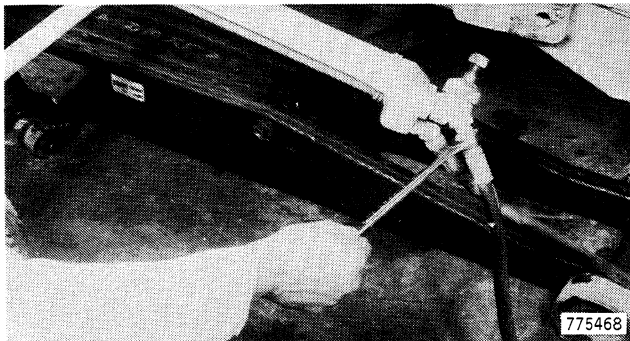

Figure 51

- 57. Drain the oil from the engine pan, Figure 54.

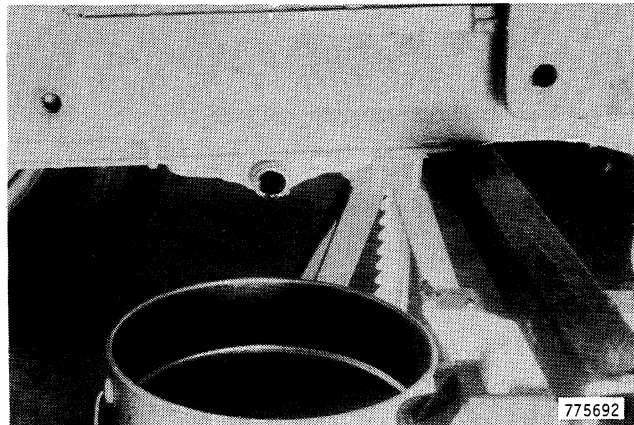

Figure 54

- 14. Bend the tabs on the tab plate over the nuts, Figure 109.

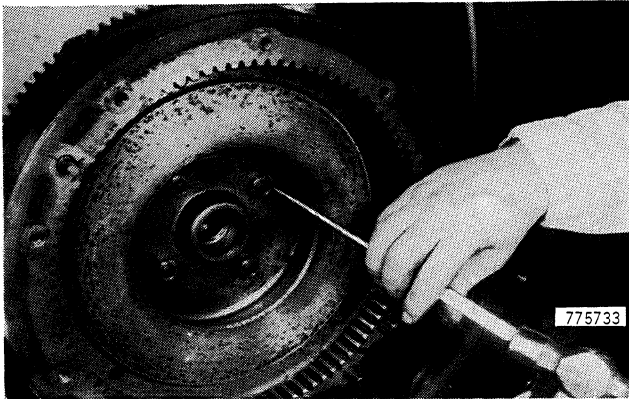

Figure 109

- 15. Put the three springs in the holes in the flywheel, Figure 110.

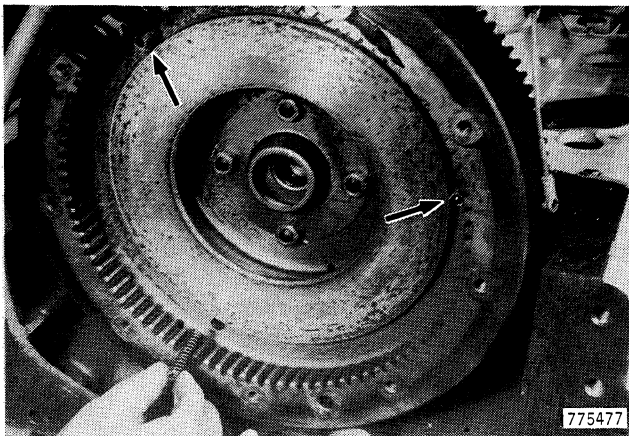

Figure 110

- 16. Install the inner clutch disc with the large hub toward flywheel as shown in Figure 111.

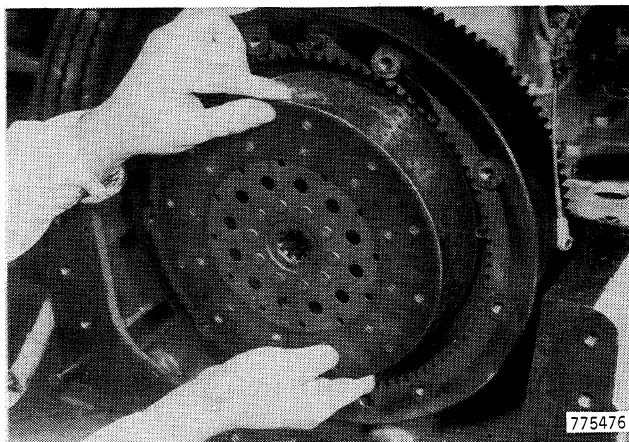

Figure 111

- 17. Install the separator plate with the marks on the separator plate and flywheel in alignment, Figure 112.

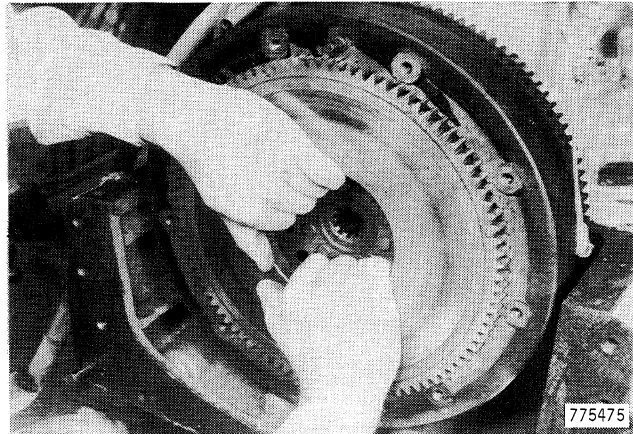

Figure 112

- 18. Install the outer clutch disc as shown in Figure 113. Outer clutch disc has the words "flywheel side" stamped on it.

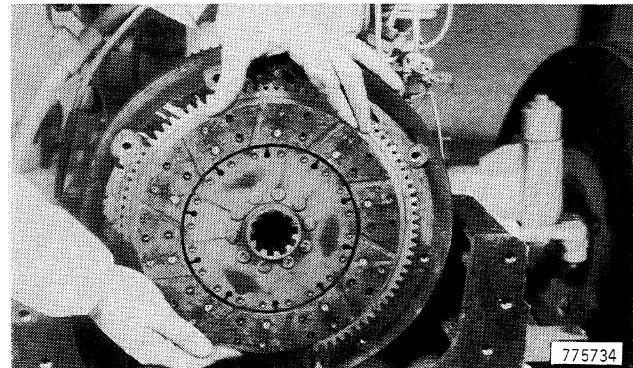

Figure 113

- 19. Install the clutch with guide pins in alignment, Figure 114.

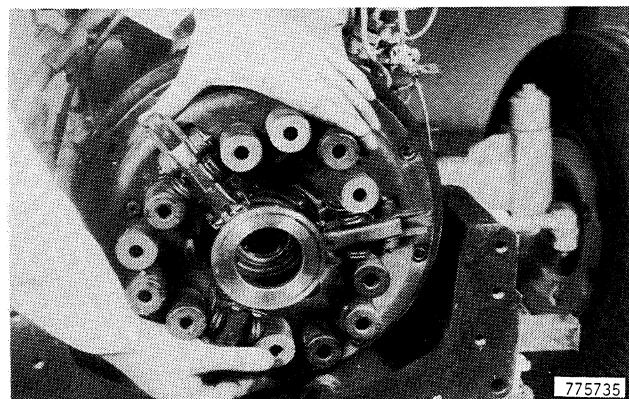

Figure 114

81. Install the steering control valve, Figure 168.

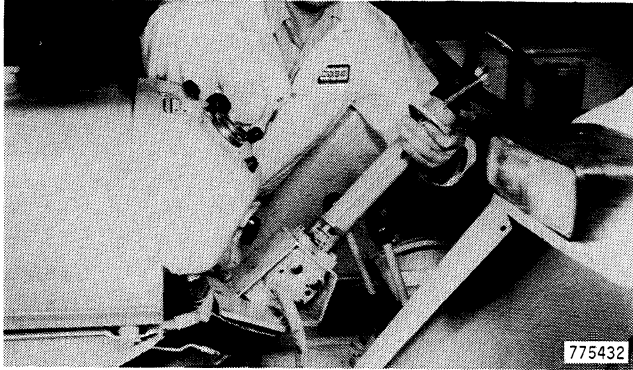

Figure 168

82. Install the steering valve cap screws, Figure 169.

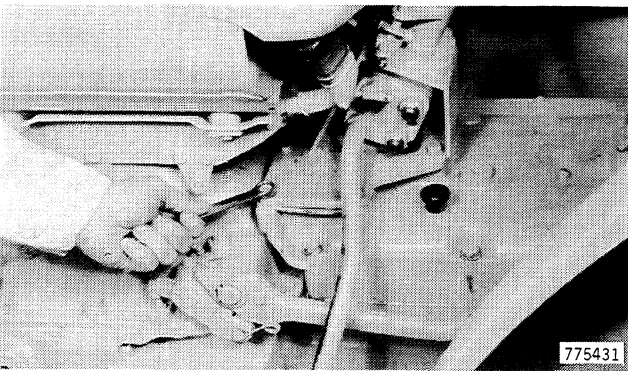

Figure 169

83. Connect the throttle linkage, Figure 170.

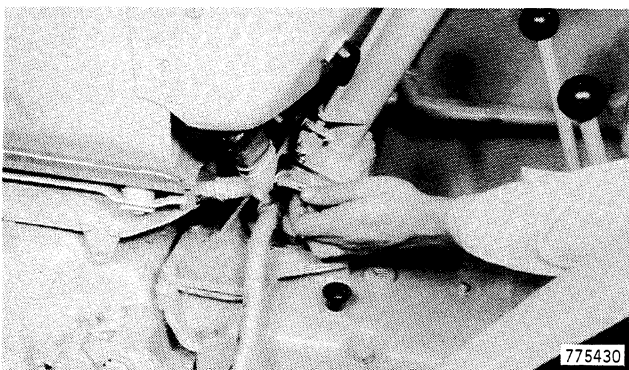

Figure 170

84. Install the hose and tube assembly to the tube from the steering pump, Figure 171.

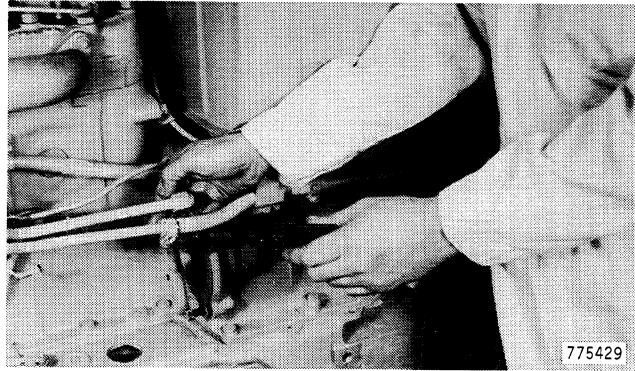

Figure 171

85. Connect the hose to the tube from the steering pump, Figure 172.

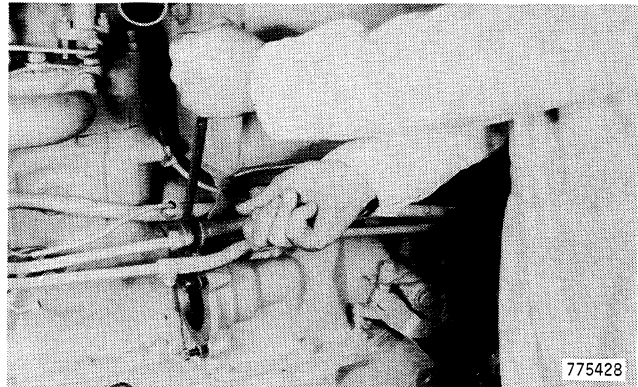

Figure 172

86. Tighten the bolt on the clamp that holds the steering tubes, Figure 173.

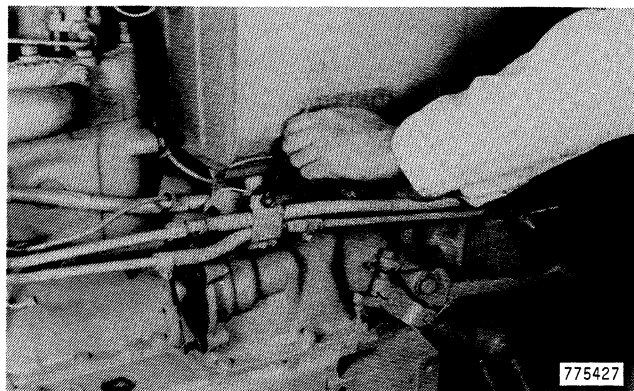

Figure 173

AIR CLEANER SERVICE

Service Interval

The air cleaner element must be serviced whenever the restriction indicator red signal remains in view. The restriction indicator is located on the right-hand side of the engine.

Filter Element Service

Washing is the preferred method of cleaning the element as it removes more dust and soot, thus restoring the element to an almost new condition.

Wash the filter in Case Filter Element Cleaner, Part No. A40910. Mix according to instructions on container. Do not use water pressure over 40 psi (275 kPa) at the nozzle. Let the element dry completely before installing. Do not use compressed air to dry the element.

Use of compressed air to clean the element is permissible but not recommended as it does not remove carbon and soot. When using compressed air, use no more than 30 psi (206 kPa) at the nozzle and keep the nozzle a reasonable distance (no closer than 1" (25 mm) away from the filter. Move the nozzle up and down each pleat, blowing from the inside only.

Inspect the filter after it is clean and dry. Place a light inside the filter and inspect for holes, tears, and dented or bent metal covering. If metal covering is dented or bent, inspect filter paper for holes or rub spots in that area. If holes or rub spots are noted, discard the filter and install a new filter element.

NOTE: Inspect new filter element in the same manner. Do not accept a defective filter.

The element must be replaced after it has been cleaned six times or once a year, whichever occurs first.

Resetting The Restriction Indicator

After the air cleaner is serviced, the restriction indicator must be reset. Press the reset button on the indicator, Figure 1. When the button is released, the red band will drop out of sight.

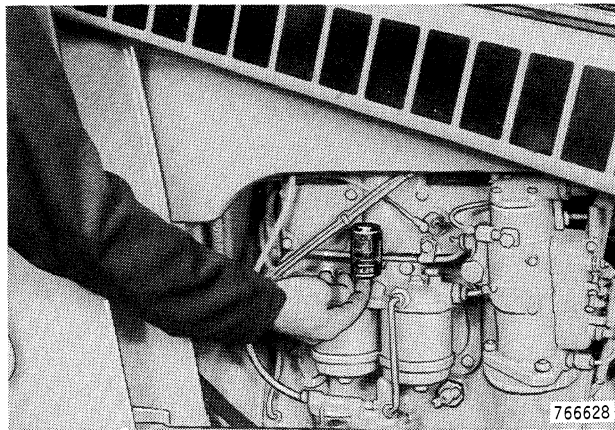

Figure 1 - Resetting Air Cleaner Restriction Indicator

Spark Arresting Muffler

Laws of some states or provinces can require that this machine be equipped with a spark arrestor or spark arresting muffler. If machine is equipped with a spark arresting muffler, a pipe plug will be found on the side of the muffler, Figure 3.

If the machine is equipped with a spark arresting muffler, any replacement muffler must also be of the spark arresting type.

The spark arresting muffler must be cleaned (loose carbon removed) after every 100 hours of operation.

1. Remove the plug from the side of the muffler. This is a brass plug. If a new plug is needed it must be made of brass.
2. Have a second person available to block the outlet pipe.
3. Put the fuel shutoff control in the Stop position.
4. Apply the parking brake. Turn switch and crank the engine for 30 seconds while the second person blocks the outlet pipe with a rag or block of wood.
5. Reinstall the brass plug in the muffler.

Preliminary Checks

Before testing the charging system check the following:

- a. Battery: The battery must be at least 75% of full charge. Refer to Specific Gravity Check in Section 4005.
- b. Connections: All connections of charging system components must be tight and free of corrosion, oxidation and other foreign matter that can cause a poor connection.
- c. Drive belt: The drive belt must be free of grease or oil which can cause slippage under load. Check for proper belt tension as instructed in section 4007.

Testing Continuity of Cable

- 1. Remove connecting plug from alternator.
- 2. Turn on the key switch.
- 3. Use a voltmeter to check for battery voltage at terminals in the plastic connector, Figure 2.

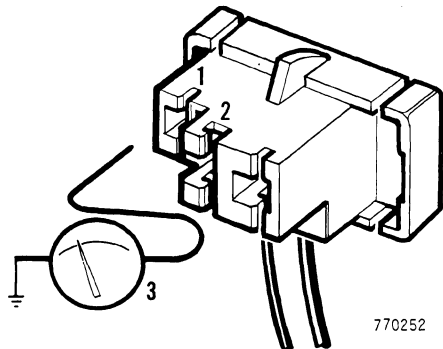

- 1. CONNECTION TO ALTERNATOR WARNING LIGHT
- 2. CONNECTION TO BATTERY
- 3. VOLTMETER

Figure 2

- a. Put one voltmeter lead in terminal 1. Put the other voltmeter lead on a clean, paint free spot on the chassis. The voltmeter must indicate battery voltage. If there is no voltage, check for a failed alternator warning bulb.
- b. Put one voltmeter lead in terminal 2. Put the other voltmeter lead on a clean, paint free

spot on the chassis. The voltmeter must indicate battery voltage. If there is no voltage, check for a broken wire between plastic connector and battery or defective connection at battery.

- c. If battery voltage is present at both terminals, connect the plastic connector to the alternator. Do not turn off the key switch. Check the alternator warning light. If it is not lit, there is an open circuit in the rotor of the alternator. Remove the alternator for disassembly and repair. If the alternator warning light is lit, do the next test.

Alternator Output Test

- 1. Remove ground cable from battery. Install battery post adapter, Figure 1, on negative battery post and connect cable to adapter.
- NOTE:** Before completing step 2, close switch on the Sun adapter or turn the switch nut up several turns on the Snap-On adapter.
- 2. Connect test ammeter to battery post adapter as indicated in Figure 4.
 - 3. Remove connector from alternator. Remove the plastic cover from alternator. Short out the regulator by installing a jumper wire as shown in Figure 3.

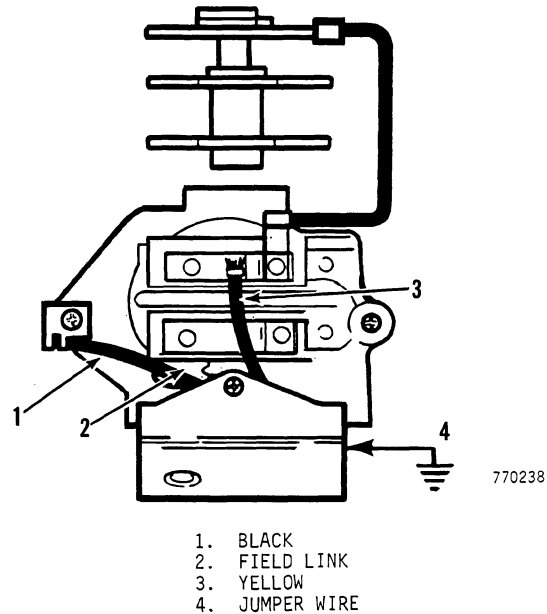

- 1. BLACK
- 2. FIELD LINK
- 3. YELLOW
- 4. JUMPER WIRE

Figure 3 - Shorting Out Regulator

TESTING THE WARNING LIGHTS

Instrument Panel Lights

There are three warning lights on the instrument panel: Engine oil pressure (green), alternator charge (red), and transmission filter (amber). See Figure 20.

When the engine is started, the green lamp will go out quickly when engine oil pressure builds up). The red lamp will go out when the engine is running above low idle speed. The amber lamp will go out when the engine is running, but if the engine is running so slowly that the red light flickers, the amber light also will flicker as both are grounded through the alternator.

Hydraulic Oil Temperature Light

A fourth warning light is installed on machines equipped with a backhoe and single hydraulic reservoir. This red light is located on the inside of the right rear fender.

This lamp will light when oil temperature in the hydraulic reservoir reaches 230° F. (146° C.).

Operation of Engine Oil Pressure Light (Green)

When the key switch is turned on, current flows through the bulb to the oil pressure switch on the engine and to ground. When the engine starts, pressure of the oil increases and opens the switch contacts. This breaks the circuit and causes the bulb to be extinguished.

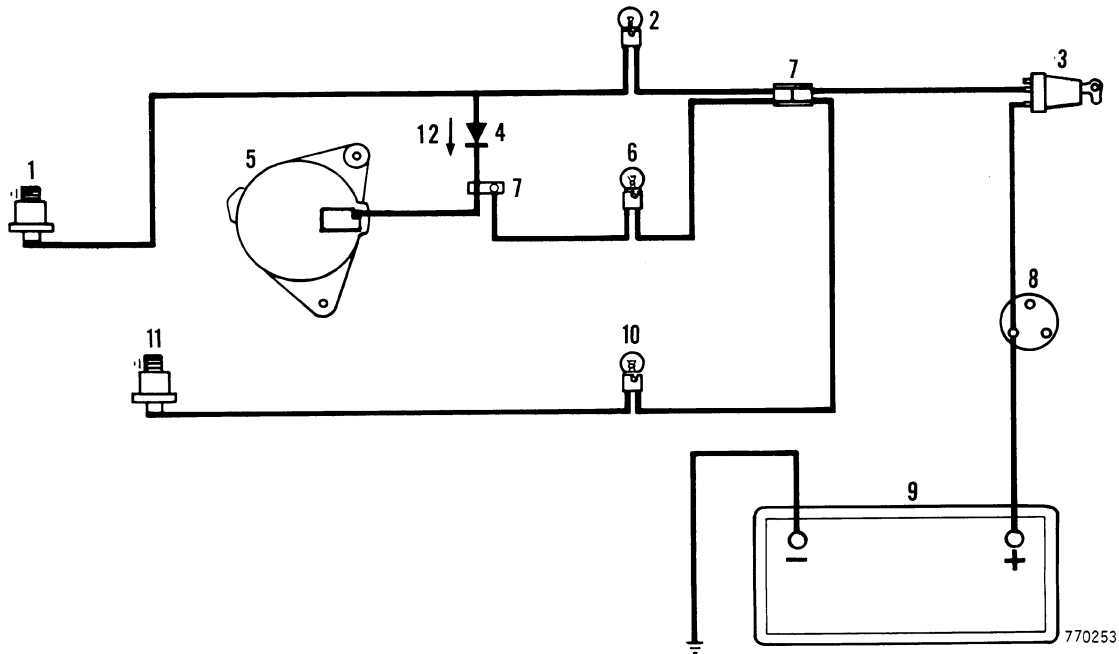

- | | |
|--|---|
| 1. FILTER VACUUM SWITCH | 7. SPLICE |
| 2. TRANSMISSION FILTER WARNING LIGHT (AMBER) | 8. STARTER SOLENOID |
| 3. KEY SWITCH | 9. BATTERY |
| 4. DIODE | 10. OIL PRESSURE WARNING LIGHT (GREEN) |
| 5. ALTERNATOR | 11. OIL PRESSURE SWITCH |
| 6. ALTERNATOR WARNING LIGHT (RED) | 12. CURRENT FLOWS IN DIRECTION OF ARROW ONLY. |

Figure 20

CARE AND MAINTENANCE

A check sheet will be found on the last page for use in battery inspections. Extra copies can be easily reproduced on any office duplicator.

Electrolyte Level

The electrolyte level must be checked every 50 hours of operation or weekly. Extensive use in hot weather will require more frequent checks because of a more rapid water loss. If the electrolyte level is low, add colorless, odorless drinking water or distilled water to each cell until the fluid level rises to the split ring at the bottom of the cell opening. Overfilling serves no useful purpose and will result in poor performance, short life and excessive corrosion around the battery.

NOTE: Add water only, not electrolyte, when servicing the battery.

Maintain the electrolyte level above the plates at all times to prevent permanent damage which will result in reduced performance and service life.

Water Usage

Excessive water usage indicates high battery temperature and/or high voltage regulator setting.

No appreciable water use over a period of time indicates an undercharged battery. Poor cable connections or a too low voltage regulator setting can be the cause.

Cleaning

The battery must be inspected periodically for dirt and corrosion, and damage. Dirt, combined with electrolyte or moisture on the top of the battery usually results in a continuous battery discharge because this foreign material produces a path for battery current to follow. Due to the higher voltage involved, 12-volt batteries are more susceptible to energy losses of this nature than 6 volt batteries.

The battery and cable terminals can be cleaned using one of the following methods:

- a. Use Case Battery Saver, part number M20376, according to instructions on container. This is a spray and wipe cleaner that requires no water. It also prevents further corrosion.
- b. Use soda or ammonia and water and flush battery with clear water. If Case Battery Saver is not available, install corrosion retarding washers under the battery cable terminals. These washers are available locally.

It is recommended that the battery be removed and the battery carrier cleaned at the same time.

TABLE OF CONTENTS

Specifications	4006- 3
Starting Circuit	4006- 4
Servicing the Starter	4006- 5
Removal	4006- 5
Disassembly	4006- 5
Bushing Replacement	4006- 9
Spring and Brush Replacement	4006- 9
Field Coil Replacement	4006-10
Inspection	4006-11
Component Testing	4006-12
Armature Tests	4006-12
Field Coil Tests	4006-13
Testing End Plate and Brush Holders	4006-13
Assembly	4006-14
Installation	4006-18

Armature

1. Test armature as instructed under Armature Tests.
2. Place armature in a lathe and turn down commutator until all indications of wear are removed. If the commutator must be turned down to less than 1.50 in (38.1 mm) diameter, replace the armature. Polish with very fine emery cloth.
3. DO NOT undercut insulators between the commutator bars.

Field Coils

1. Check field coils as instructed under Field Coil Tests.

Bushings

1. If the three bushings do not meet the specifications on page 4006-3, replace them with new parts. Soak new bushings in engine oil for 24 hours before installing. Do not ream bushings.

Roller Clutch (Starter Drive)

1. The roller clutch will rotate smoothly in one direction. It will not rotate in the opposite direction. There must be no tendency to bind. Replace the roller clutch if it does not meet these requirements.
2. The roller clutch is a sealed unit and must not be washed or lubricated.

Component Testing

Armature Tests

ARMATURE GROUND TEST

1. Place armature in growler of tester. Turn on power, Figure 30.
2. Touch one test probe to armature core, the other probe to commutator. If test lamp glows, the armature winding or commutator is grounded.

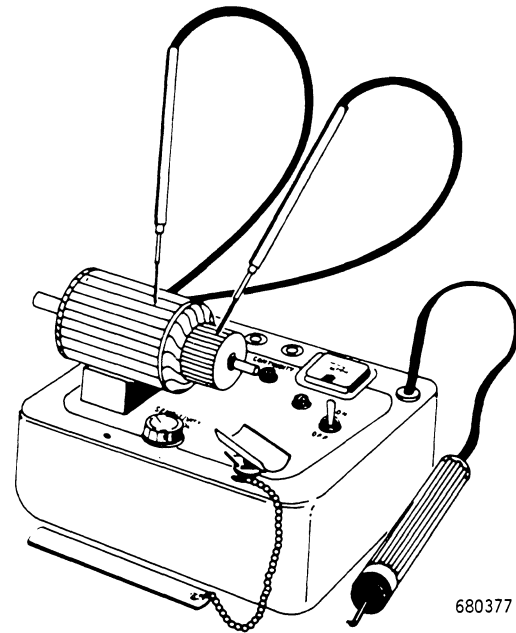

Figure 30 - Armature Ground Test

ALTERNATOR CHARGING CIRCUIT

The alternator charging circuit consists of the battery, alternator with self contained voltage regulator, key switch, alternator warning light, and related wiring. The circuit is schematically illustrated in Figure 1.

The alternator components are the front frame assembly, rear frame assembly, rotor, stator, voltage regulator, and rectifier assembly which contains the diodes.

When the key switch is turned on, battery current flows through the alternator warning light and through the brushes to the rotor windings. This causes the alternator warning light to light and provides initial current to the rotor (field) windings.

When the engine is started, the revolving rotor induces current in the stator windings and this is fed into the rotor windings. As increased current through the rotor windings results in a further increase in current generated by the stator windings, a rapid buildup of current takes place. When voltage produced by the stator windings is greater than the voltage of the battery, current flows to the battery and the alternator warning light is extinguished to show that battery charging is taking place.

The diode pack in the rectifier changes the alternating current (A.C.) generated in the stator windings so that direct current (D.C.) is supplied to the battery and rotor windings.

Diodes have a high resistance to current flow in one direction and a low resistance in the opposite direction. They are connected to permit current flow from the alternator to the battery in the low resistance direction. The high resistance of the opposite direction prevents the flow of current from the battery to the alternator.

The alternator output is regulated by varying the field current. This is accomplished through the use of a completely transistorized voltage regulator which turns on and shuts off the field and maintains a predetermined voltage.

When the battery approaches a fully charged condition, the voltage regulator reduces the current supplied to the rotor field windings so that the charging rate is reduced to suit battery condition. The alternator will not charge if the alternator warning light has failed.

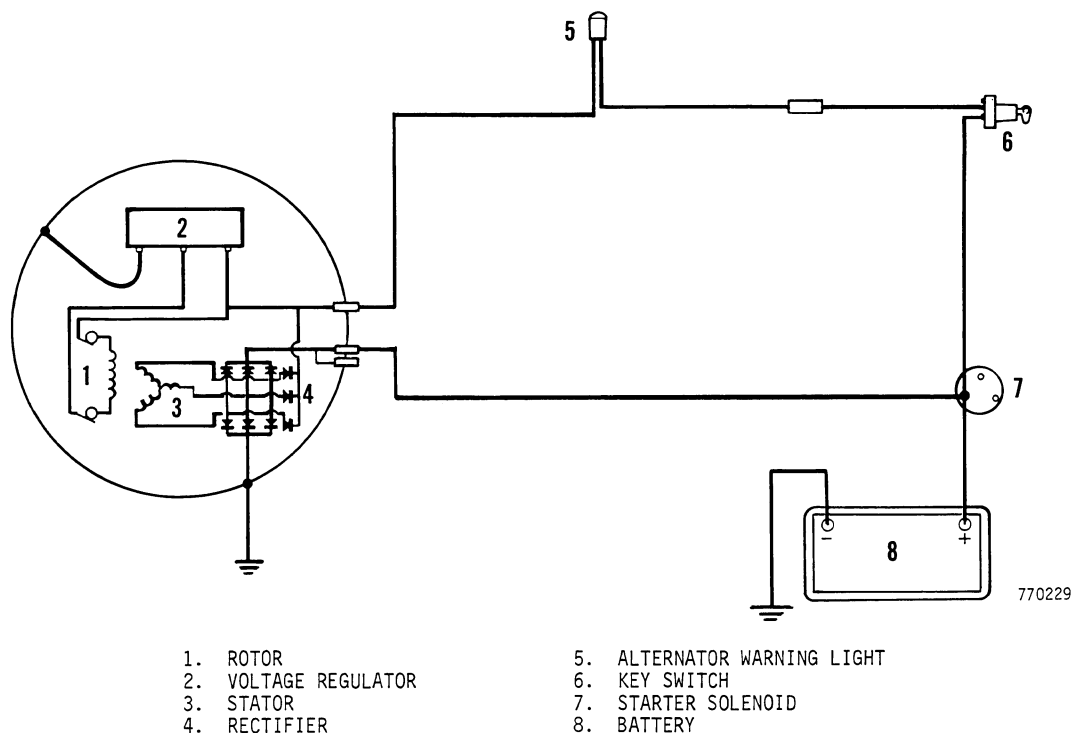

Figure 1 - Alternator Charging Circuit

Assembly

1. Install seal in front frame, Figure 35.

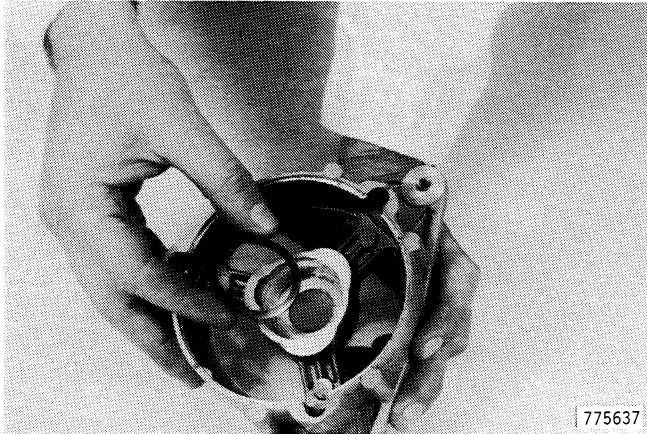

Figure 35

2. Tap new bearing into front frame, Figure 36.

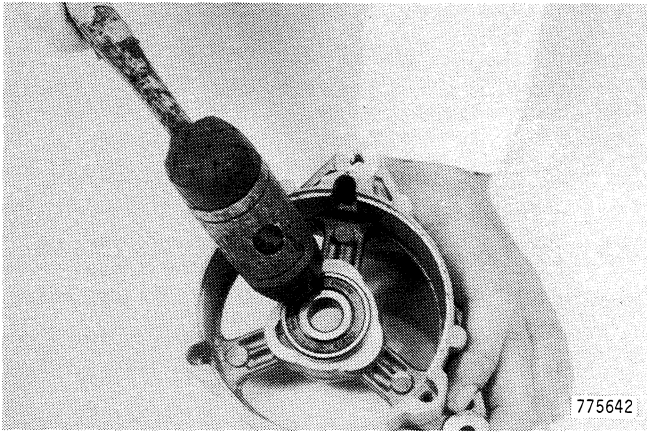

Figure 36

3. Install dust seal. Install snap ring in groove in front frame, Figure 37.

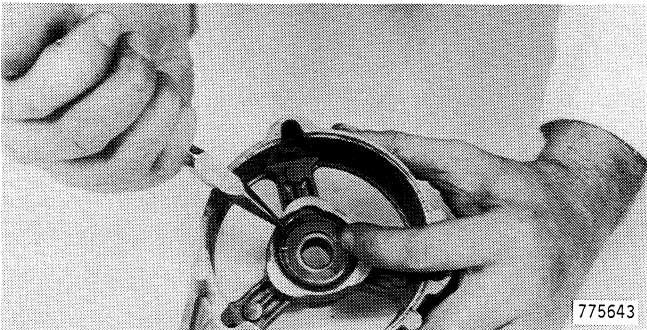

Figure 37

4. Install spacer on rotor shaft, Figure 38. This spacer is the longer of the two spacers used on the rotor shaft.

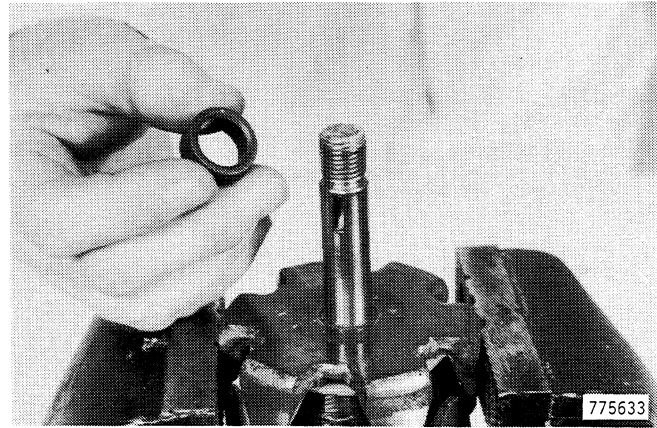

Figure 38

5. Use bearing sleeve specified on page 4007-3 and install front frame on rotor shaft, Figure 39. Drive until front frame contacts the spacer.

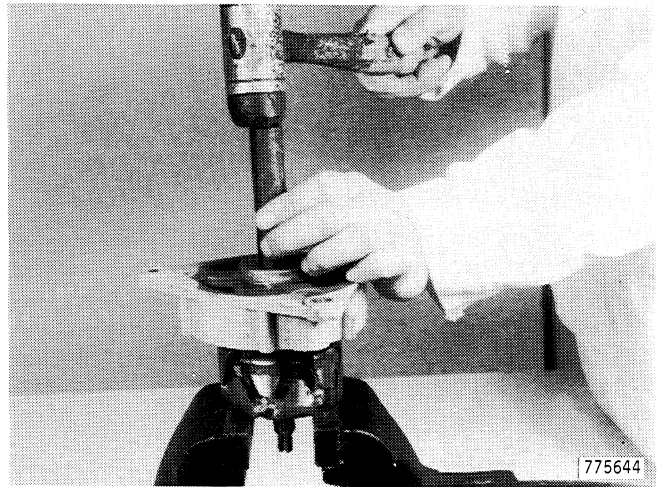
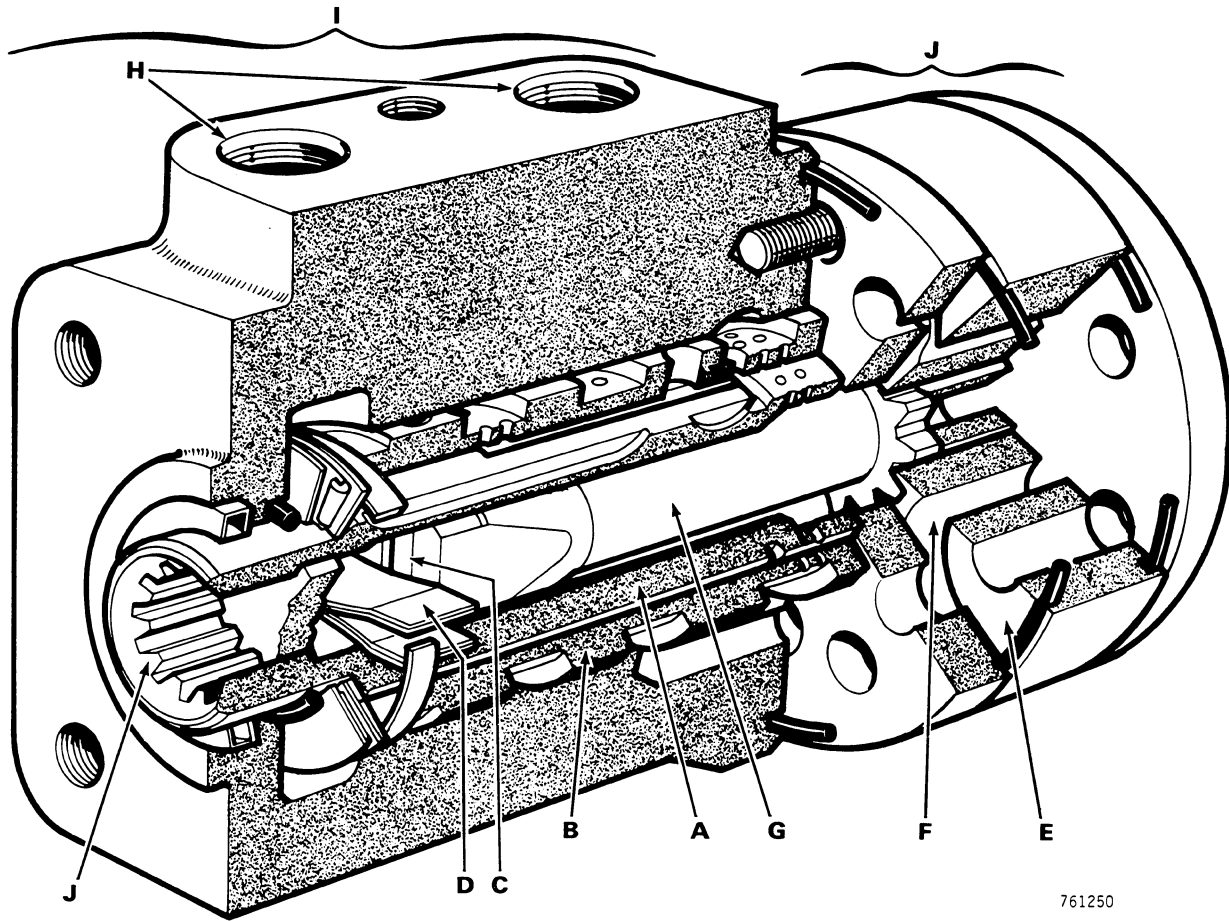

Figure 39



761250

- | | |
|---------------------|------------------|
| A. INNER SLEEVE | F. ROTOR |
| B. OUTER SLEEVE | G. DRIVE SHAFT |
| C. DRIVE PIN | H. PORTS |
| D. CENTERING SPRING | I. ROTARY VALVE |
| E. STATOR | J. METERING UNIT |

Figure 3 - Steering Control Valve (Danfoss)

ASSEMBLY

1. If shaft seal was removed, clean seal bore in body and apply a light coat of No. 3 Permatex or equivalent to seal bore. Then press new seal into bore.
2. Install new O-rings on the driven gear and drive shaft front bearings.
3. The front bearings are a close fit in the body, but when properly lined up they will slide into place. Install the bearings at the same time with the flats together and the tapered surfaces up (toward gears). Do not force the bearings into place. Lubricating the bearings and bearing bore will aid in installation. Be sure bearing with the long sleeve is installed in the drive shaft bore.
4. Lubricate both gears and install them in the body. Use care not to damage the shaft seal.
5. Install the rear bearings in the same manner as the front bearings with the tapered bearing surfaces towards the gears.
6. Place new O-ring in groove in the intermediate cover. Use grease to hold O-ring in place if necessary.
7. Place new O-ring in groove in end of relief valve.
8. Then install relief valve in intermediate cover so it extends through cover 7/16 inch (11 mm).
9. Secure the body in a vise and place intermediate cover on body. Then place a new gasket and the rear cover on the intermediate cover.
10. Install the six long cap screws in holes in rear cover and the short cap screw in the intermediate cover. Tighten cap screws evenly to 9-11 foot-pounds (12-15 N m).
11. Tighten relief valve to 10-12 foot-pounds (13-16 N m). Then tighten lock nut to 18-20 foot-pounds (24-27 N m).
12. Install new filter and secure in place with washer, spring and nut. Screw nut onto stud to obtain the dimension shown in Figure 1. The nut must be properly installed to prevent damage to the reservoir.
13. Install reservoir and align mark made during disassembly. Secure reservoir in place with copper washer and nut. Tighten nut to 20-25 foot-pounds (27-34 N m).
14. Place Woodruff key in slot in drive shaft. Install pulley and secure in place with washer and nut. After tightening nut, install new cotter pin.

INSTALLATION

1. Assemble bracket to pump, then mount bracket to engine block with two bolts and lock washers.
2. Install belts on pulley and adjust so there is 1 inch (25 mm) deflection with firm thumb pressure midway between the fan and pump pulleys. See page 4007-18.
3. Connect tubes to pump.
4. Bleed air from the hydraulic system:
 - a. Fill reservoir to within 3/8 inch (10 mm) of the filler rim with Case TCH Fluid. Jack up the tractor so the front wheels are off the ground.
 - b. With fuel shutoff control in Stop position, crank engine for 10 to 15 seconds to prime the pump. Check reservoir oil level.
 - c. Start engine and run at low idle. Turn steering wheel one full turn in each direction. Do not turn wheels against the stops.
 - d. Check reservoir oil level and add oil if required.
 - e. Turn steering wheel until wheels are against stops. Hold for a few seconds, then turn wheels against stops in the opposite direction. Perform this step several times.
 - f. Lower the front wheels to the ground. Check oil level and add oil if required. Drive tractor at low speed in a figure eight pattern to check steering action. The steering must operate smoothly and without hesitation.

Assembly

1. Before reassembly of individual parts, make sure that they are lubricated with Case TCH Fluid. Assemble the control valve spool and sleeve, Figure 16. The fit between these two mating parts is very close, as indicated previously, therefore perfect alignment is required during reassembly. If the spool is chilled in a refrigerator or deep freeze prior to reassembly, it will ease the fitting of these two parts. As the control valve spool and sleeve is assembled together, it will be necessary to make sure that the centering spring slots are aligned.

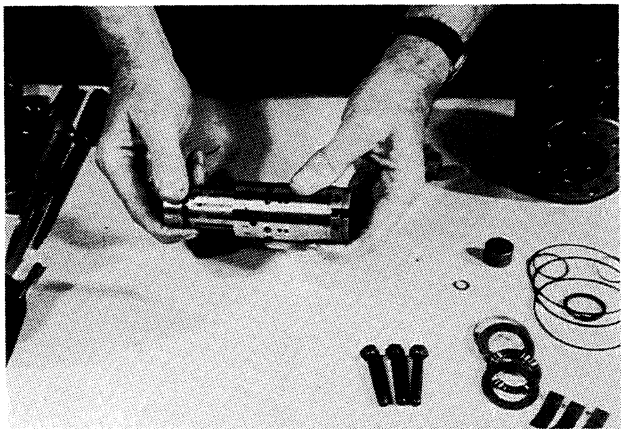

Figure 16

2. Figure 17 shows the position of the six centering springs in the CAS-1239 special tool.

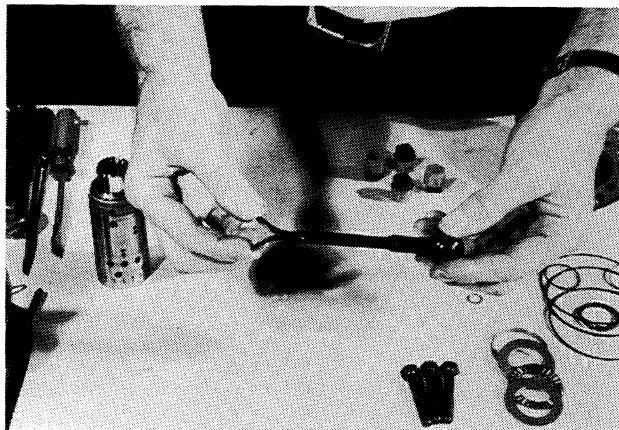

Figure 17

3. Insert the special tool into the centering spring slot in the control spool and sleeve and insert the centering springs in the slot of the tool, Figure 18. Using finger pressure, compress the ends of the springs opposite the special holding tool and slide the springs into the control spool and sleeve as the special tool is pushed out.

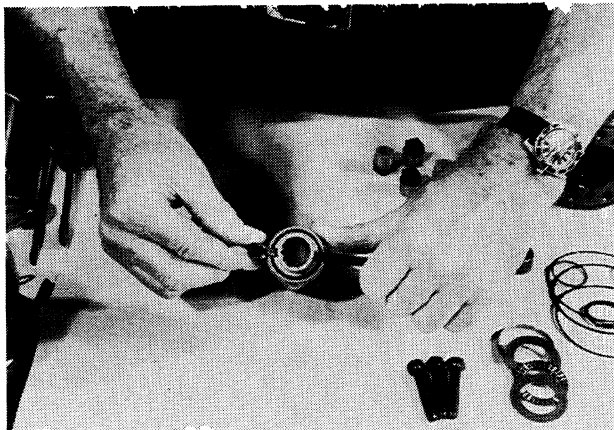

Figure 18

4. At this point, the cross pin (drive pin) must be pushed through the control valve spool and sleeve until it is flush with the sleeve, Figure 19.

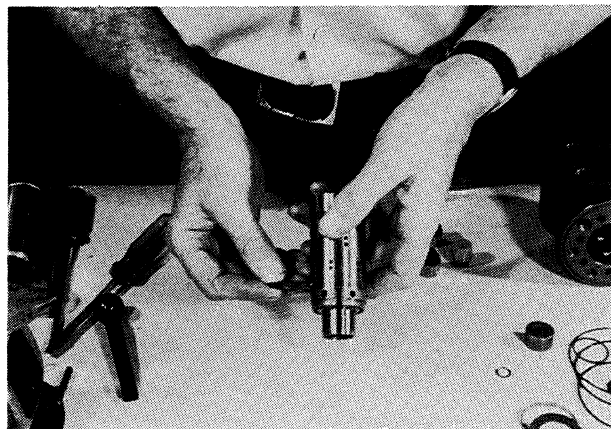

Figure 19

Assembly

1. Install check valve spring in bore, large end first. Drop ball onto spring and turn check valve seat, recessed end first, into bore. Tighten valve seat to 150 inch-pounds (16.9 N m). Install new O-ring on plug and install in bore.
2. Carefully install the spool in the sleeve with the centering spring slots in both parts at the same end. Rotate the spool while sliding the parts together. Check for free rotation. The spool must rotate freely with finger tip force at the splined end.
3. Align the spring slots in the spool and sleeve and install the centering springs. Use special tool shown in Figure 1.
 - a. Insert the tool through the spring slots in the spool and sleeve.
 - b. Position the springs in sets of 3 with the arched centers together. Enter one end of the complete spring set into the notch in the tool with the notched corners of the springs toward the gear end of the spool.
 - c. Compress the extended end of the spring set with your fingers. Push the springs into the spool-sleeve assembly, using the tool to guide the springs into the opposite slot. Center the spring set in the sleeve and make sure the springs are flush with the top of the sleeve.
4. Install the cross pin in the spool-sleeve assembly.
5. Install the spool-sleeve assembly, splined end first, through the gear end of the housing. Push the sleeve into the housing with a twisting motion (to prevent binding and damage) until flush with the gear end of the housing.
6. Place a thrust washer, thrust bearing and the remaining thrust washer on the spool. Align the bearing and washers and install bearing retainer.
7. Install new seal, lip toward steering column, in cover. Then install the quad ring and O-ring in cover.
8. Place the valve housing on a clean, smooth surface, gear end down. Lubricate the cover seal, quad ring and O-ring with hydraulic oil and install over spool.

9. Install four capscrews that attach the cover to the housing. Tighten the capscrews to 250 inch-pounds (28.2 N m).
10. Secure the valve housing in the vise with the gear end up. Clean the gear end surface of the housing with the palm or thumb. Be sure your hand is clean.
11. Clean the rear ring and the plate in the same manner.
12. Install the gear on the driveshaft. The pin slot in the driveshaft must be in alignment with the valleys on the gear as illustrated in Figure 42. Then install the drive shaft in the spool. Rotate the gear as required until the driveshaft engages the cross pin.

NOTE: Alignment of the slot and cross pin with the gear valleys determine proper valve timing of the unit. If the parts slip out of position during step 12, repeat until you are certain that correct alignment is obtained.

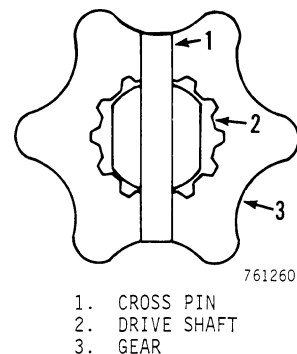

Figure 42 - Gear and Cross Pin Alignment

13. Place the plate on the housing making sure holes are aligned. Then place the mating gear ring on the plate.
14. Place the spacer in the gear and install the end plate. Install the seven capscrews and tighten in increments of 50 inch-pounds (5.6 N m) until tightened to 250 inch-pounds (28.2 N m).

Installation

See page 5007-3.

Installation

1. If pivot pin bushings were removed, install new bushings:
 - a. Coat outside of bushings with light oil. Make sure bore of axle is free of burrs.
 - b. Press bushings into axle until the bushing contacts shoulder in axle. One bushing goes into the front of the axle, two bushings are located in the rear of the axle, Figure 5.
2. Install O-ring in groove on end of pivot pin.
3. Install thrust washer in recess at front and rear of axle.
4. Install a sealing ring over both thrust washers.
5. Coat the inside of the pivot pin bushings with grease. Jack up the axle so the pivot pin can be installed, carefully aligning the axle bores with bores in the frame so that the pivot pin can be tapped into place.
6. Install pivot pin until retaining pin holes are lined up. Install retaining pin.
7. Install plug at front of frame.
8. Lubricate axle at grease fitting on axle. Use Case FDL multipurpose gear lubricant or SAE 140 gear lubricant. Lubricate until lubricant starts to run out front and rear of axle.

TOE IN ADJUSTMENT

The toe in at the front of the wheels should be 1/8 inch (3 mm). Measurements are taken at the front and rear of the wheel rims to determine the amount of toe in. Adjustment is made by turning the tie rod at the rear of the axle.

3. Repeat measurement at the rear of the wheel rims.
4. The measurement at the front of the tires should be 1/8 inch (3 mm) less than the measurement at the rear of the wheel rims.

Measuring Toe In

1. Park the machine with the wheels straight ahead.
2. Measure the distance between the front of the wheel rims at points level with the wheel centers and parallel to the center line of the front axle.

Adjustment

1. Loosen lock nut at both ends of tie rod.
2. Turn the tie rod as required to increase or decrease toe in. Then tighten the lock nuts.

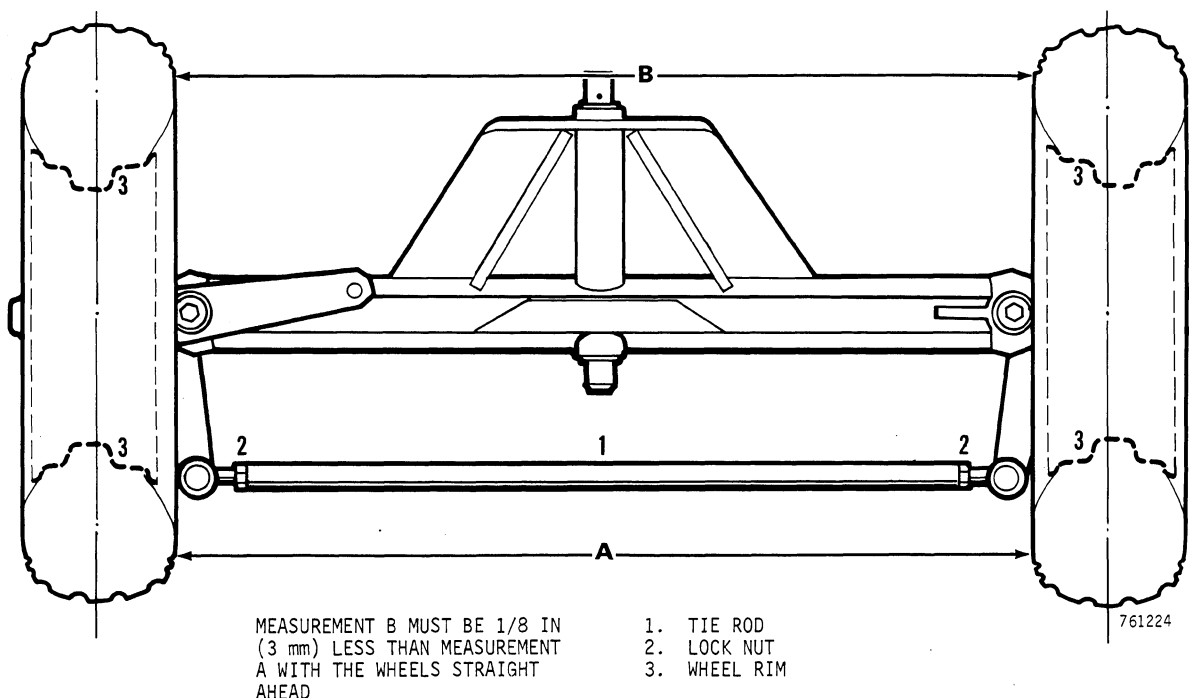

Figure 6 - Toe In Adjustment

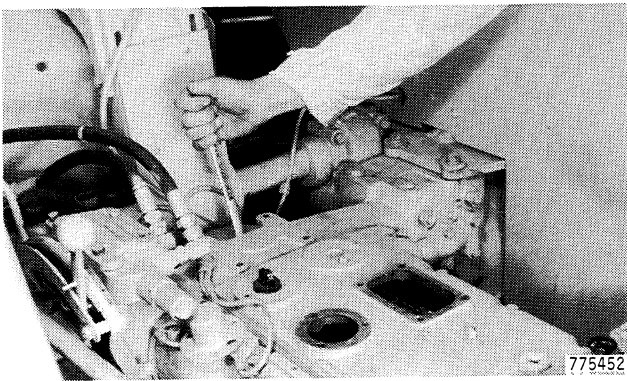

Figure 35

38. Remove the cap screws from the transmission cover, Figure 36.

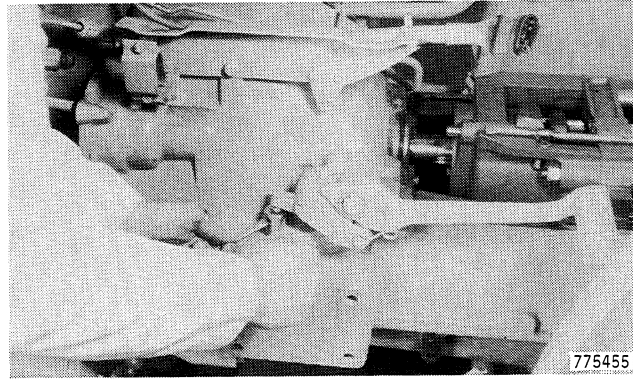

Figure 38

41. Remove the cap screws from the clutch housing, Figure 39.

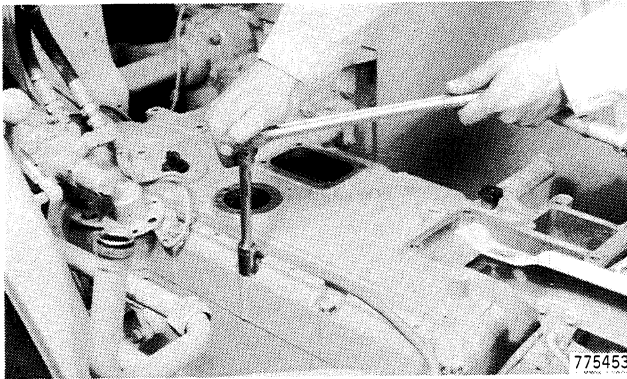

Figure 36

39. Remove the transmission cover plate, Figure 37.

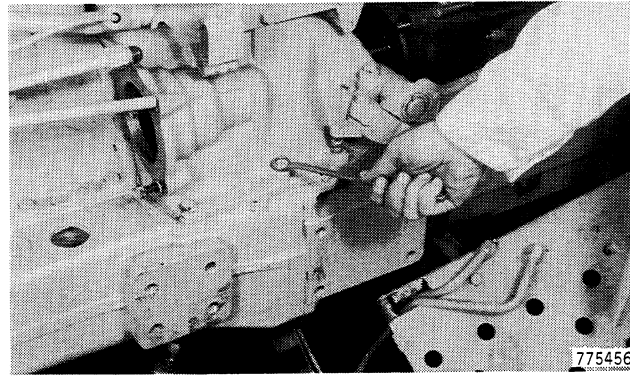

Figure 39

42. Disconnect the throttle cable, Figure 40.

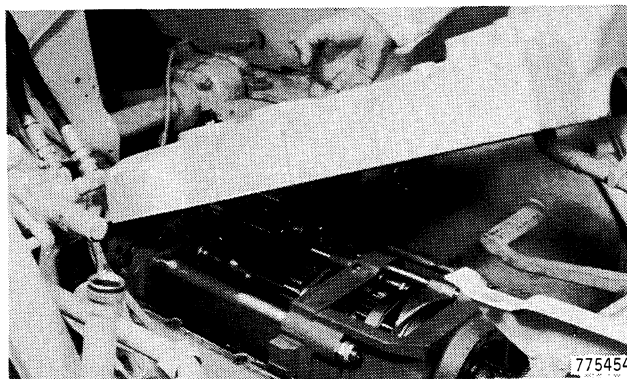

Figure 37

40. Loosen the lock nut on the clutch adjustment cap screw. Turn clutch adjustment cap screw in until clutch pedal comes all the way up, Figure 38.

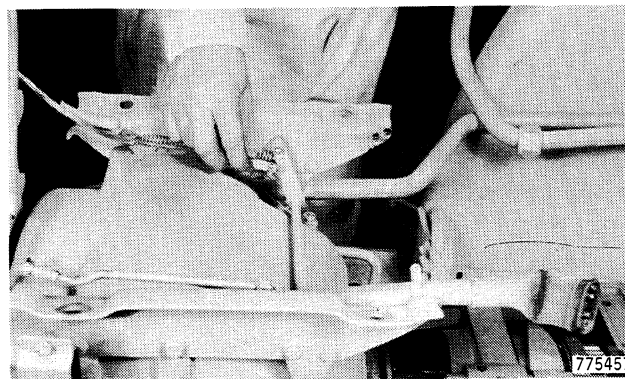

Figure 40

43. Disconnect the throttle cable spring, Figure 41.

30. Turn the outer cover over and tap the bearing out with a punch and hammer, Figure 91.



Figure 91

CLUTCH ASSEMBLY

1. Inspect the springs, bearings, and release levers for wear and cracks.
2. Inspect the pressure plate, replace if it is cracked, deeply scored or blued.
3. Install the outer cover bearing, Figure 92.

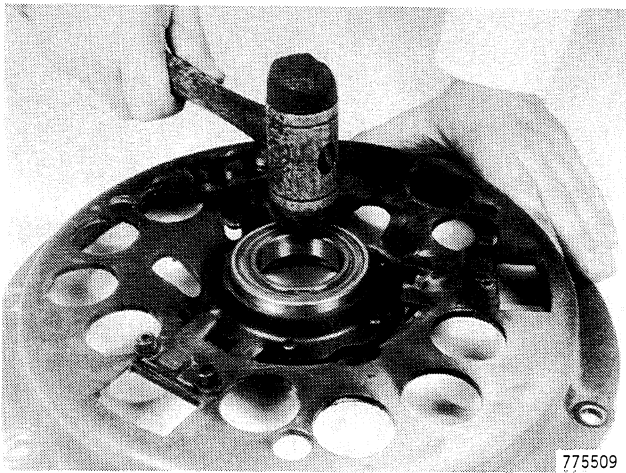

Figure 92

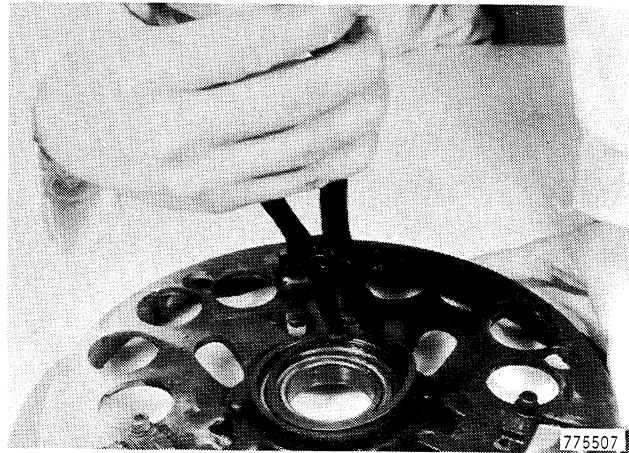

Figure 93

4. Install the outer cover bearing snap ring, Figure 93.

5. Put the K912917 base plate on a clean bench. Put the three code 14 spacers around the center of the base plate. Position the spacers so that when the pressure plate is put on the base plate the spacers are below the release lever lugs, Figure 94.

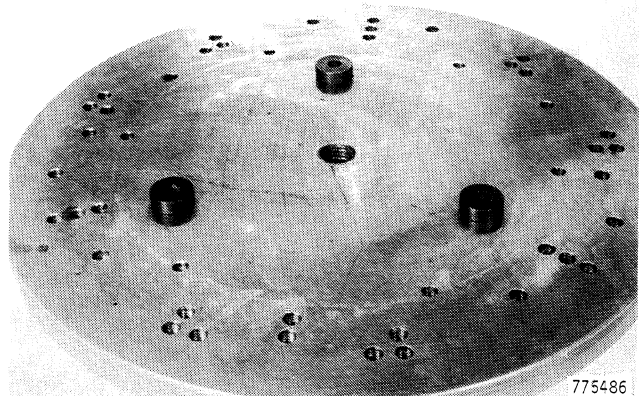

Figure 94

CLICK HERE TO **DOWNLOAD** THE COMPLETE MANUAL

- Thank you very much for reading the preview of the manual.
- You can download the complete manual from: www.heydownloads.com by clicking the link below



- Please note: If there is no response to CLICKING the link, please download this PDF first and then click on it.

CLICK HERE TO **DOWNLOAD** THE COMPLETE MANUAL

17. Install the two outside cap screws underneath the front housing through the front and rear housings and into the steps, Figure 144.

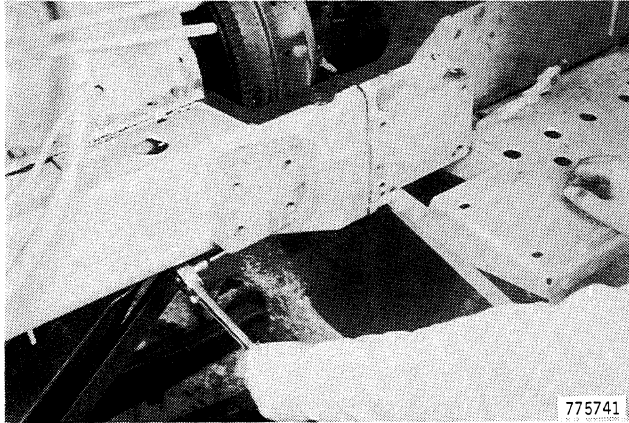

Figure 144

18. Install the remaining cap screws that hold the front and rear housings together, Figure 145.

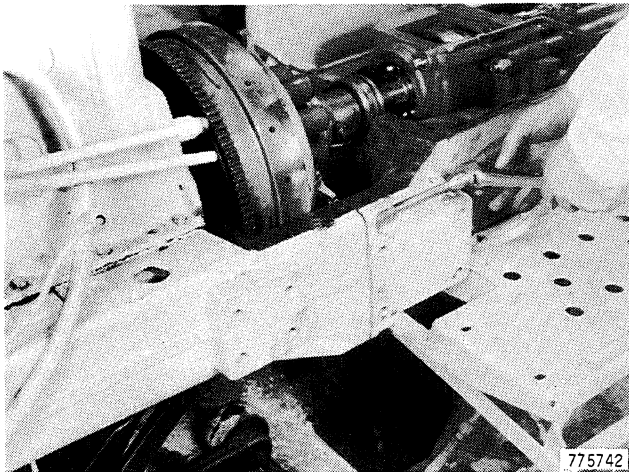

Figure 145

19. Remove the jack.
20. Remove the blocks of wood from between the axle and main frame, Figure 146.

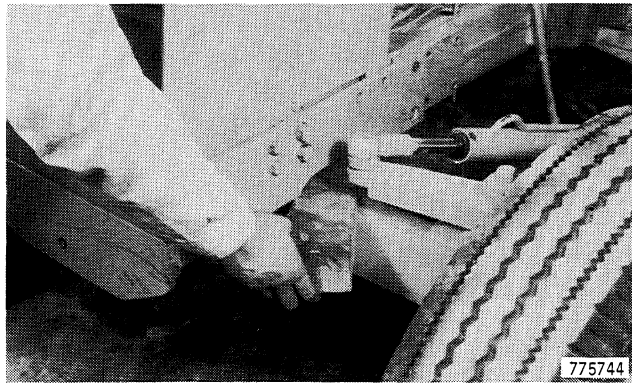

Figure 146

21. Remove the stand from beneath the rear housing.
22. Install the backhoe tubes and clamping hardware.
23. Install the dipstick housing using a new gasket, Figure 147.

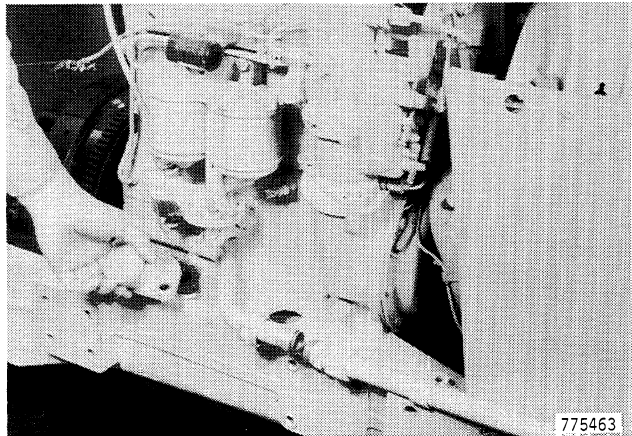

Figure 147

24. Connect the tube from the hydraulic pump to the backhoe, Figure 148.

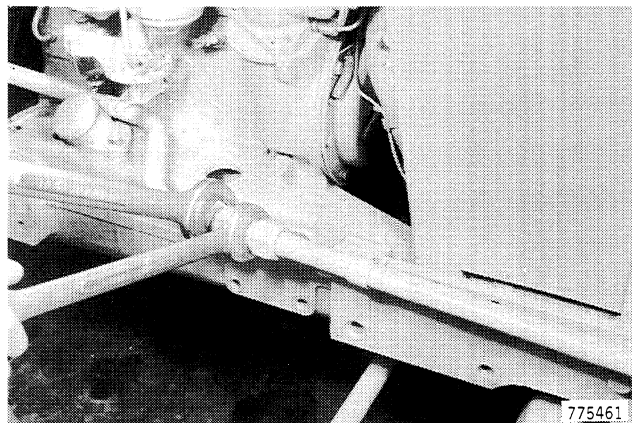
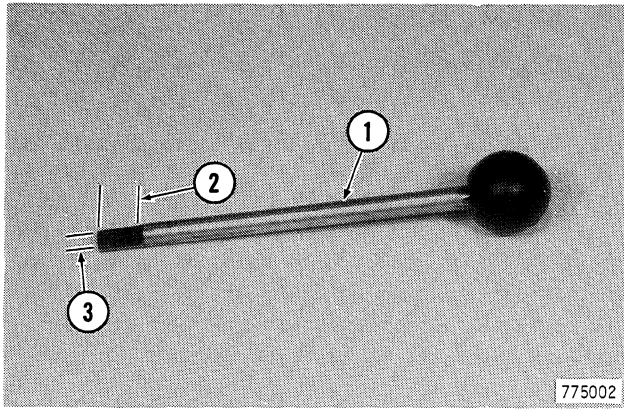

Figure 148



1. .375 Inch (9.5 mm) Round Bar
2. .75 Inch (19 mm)
3. .18 Inch (4.6 mm)

Figure 3 - Detent Installation Tool

Removal

1. Remove backhoe, if so equipped, as instructed in Section 9100.
2. Loosen the nuts on the loader strut rods. Remove the cotter pins and flat washers from the drawbar hinge pin and remove struts from pin.
3. Support drawbar with a floor jack or suitable lifting device and remove self-locking nuts from drawbar hinge brackets.
4. Remove nuts and bolts from rear mounting bracket and remove drawbar, Figure 4.

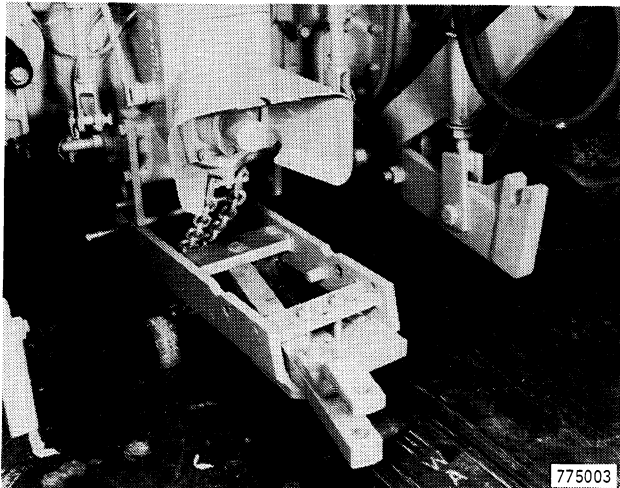

Figure 4

5. If machine was equipped with backhoe, remove backhoe mounting arms, Figure 5. The arms weigh approximately 120 pounds (54 kg). Provide suitable lifting equipment or additional help when removing the arms.

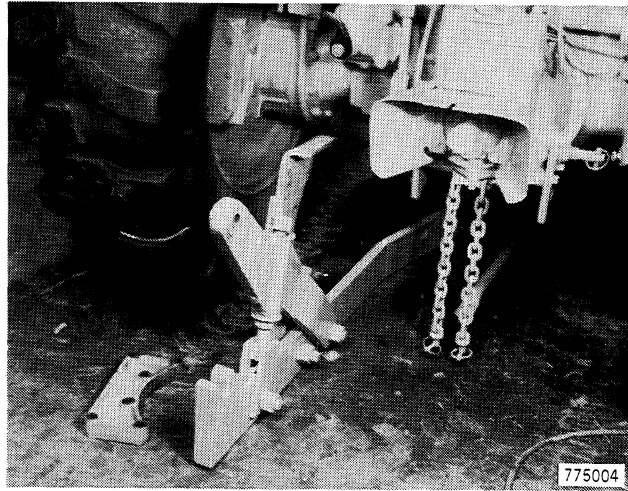

Figure 5

6. Have on hand clean drain pans and containers that will hold approximately 5 U.S. gallons (18.9 litres) and drain the rear axle.
7. Remove selectamatic oil filter restriction indicator sending unit, Figure 6.

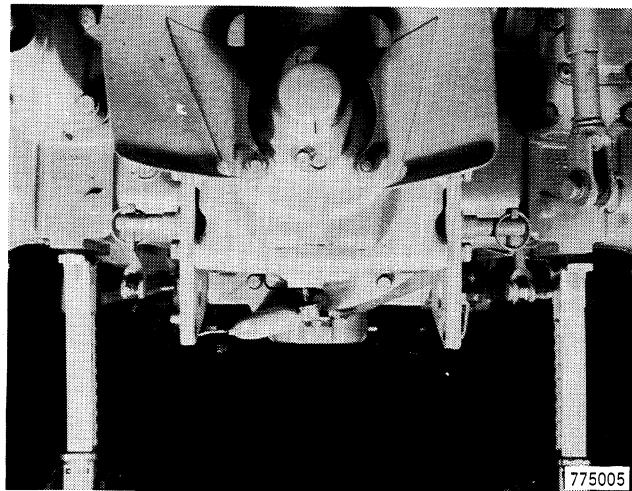
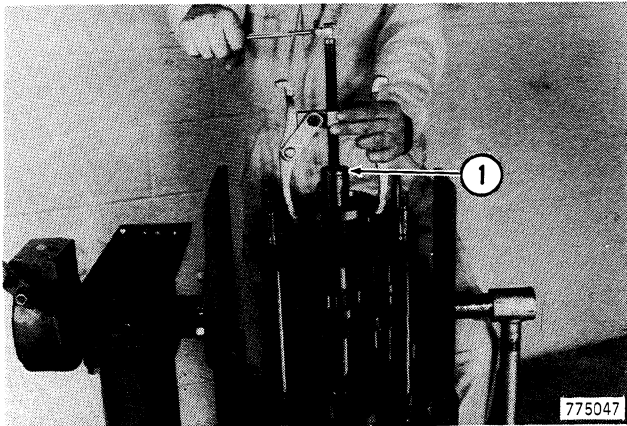

Figure 6

8. Disconnect wire from sending unit and place out of the way.

21. Using a suitable gear puller and stepped plate remove the reverse gear from the input shaft, Figure 49.

NOTE: If stepped plate is not available, a 1 inch (25 mm) diameter bolt will work in place of the stepped plate.



1. Stepped Plate

Figure 49

22. Remove spacer from reverse gear, Figure 50.

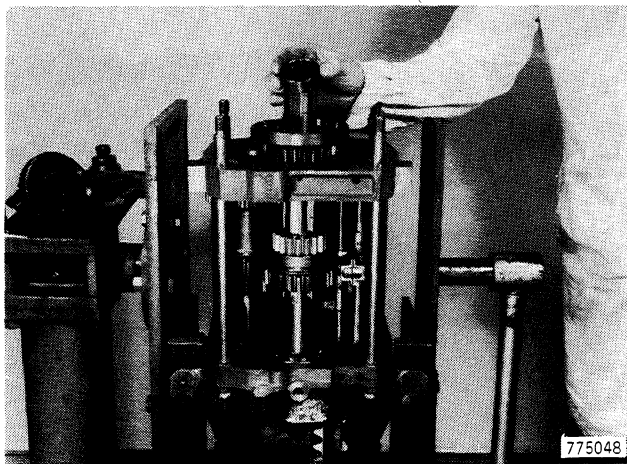

Figure 50

23. Remove reverse gear, Figure 51.

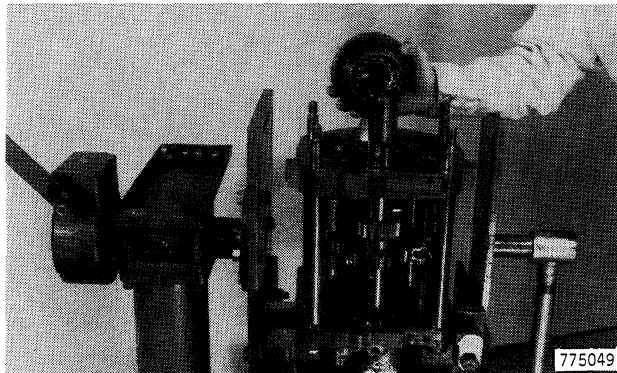

Figure 51

24. Remove spacer from pinion shaft, Figure 52.

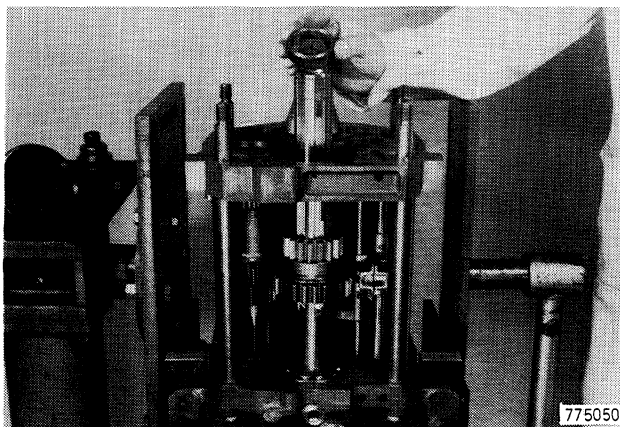

Figure 52

25. To remove bearings from reverse gear, remove snap ring, Figure 53.

NOTE: Remove bearings only if inspection indicates they must be replaced.

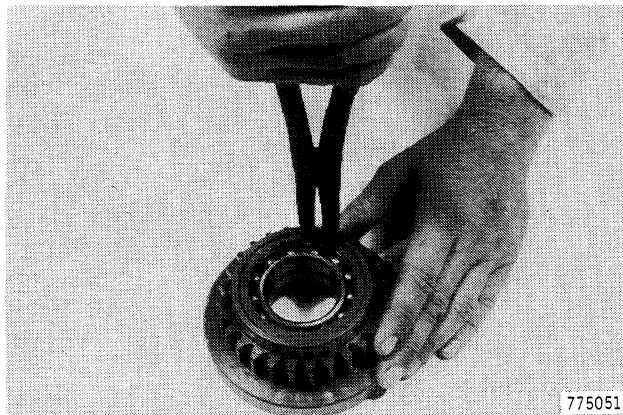

Figure 53

44. Remove the bearing retaining plate, Figure 102.

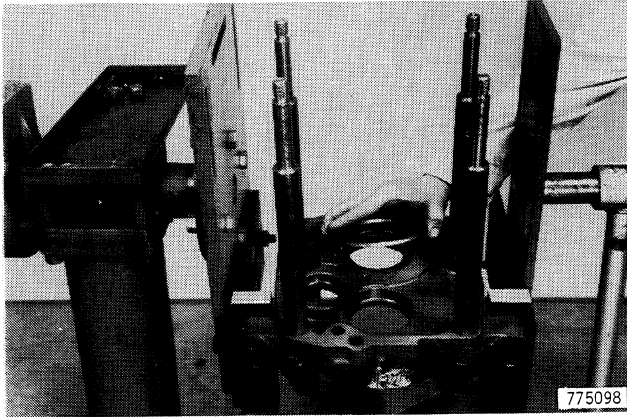

Figure 102

45. Remove the pinion bearing cup shims, Figure 103. Keep shims together. They will be used during assembly.

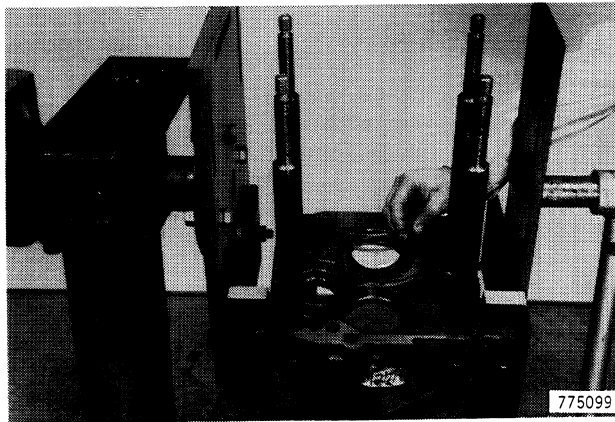

Figure 103

46. Lift out the pinion bearing cup, Figure 104. The cup should lift out but may have to be tapped out with a punch and hammer.



Figure 104

47. Remove the self-locking nuts from the tie bolts, Figure 105.

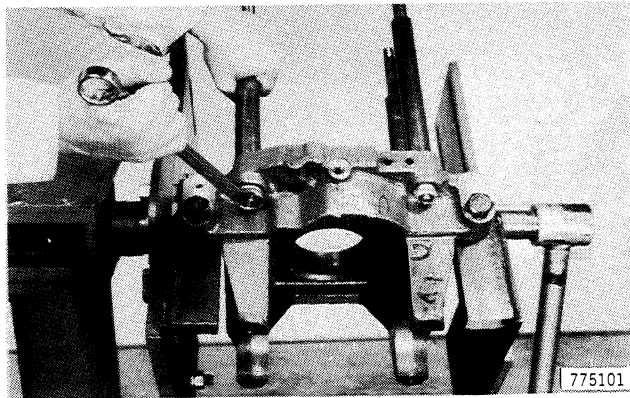

Figure 105

48. Remove the two tie bolts that were retained by self-locking nuts, Figure 106.

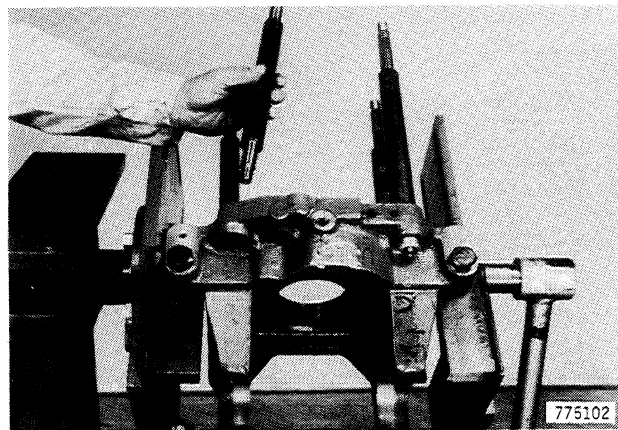

Figure 106

7. Install bearing cup by tapping with a soft hammer, Figure 154.

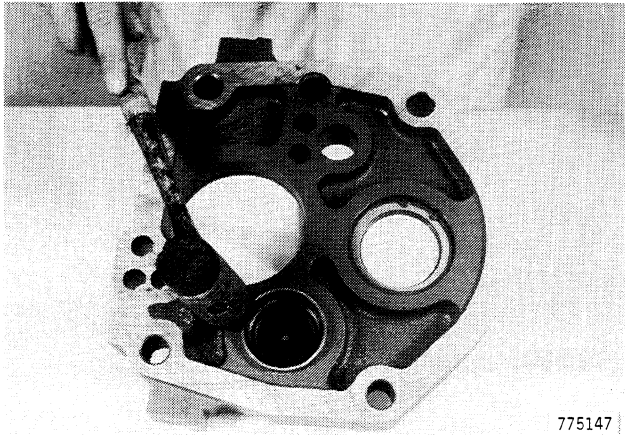

Figure 154

8. Install snap ring in input shaft mounting hole, Figure 155.

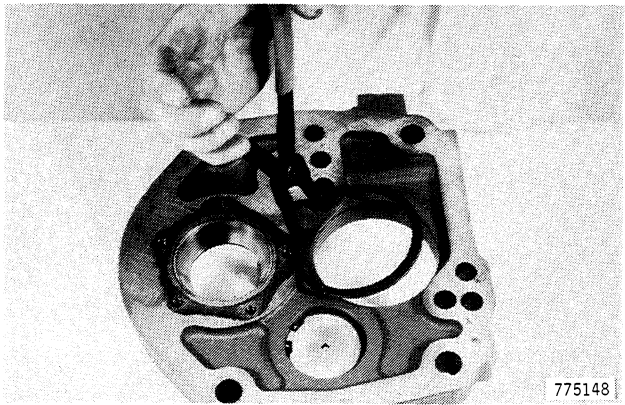

Figure 155

Pinion Shaft and Differential Adjustments

1. Install separator plate over tie bolts as shown in Figure 156.

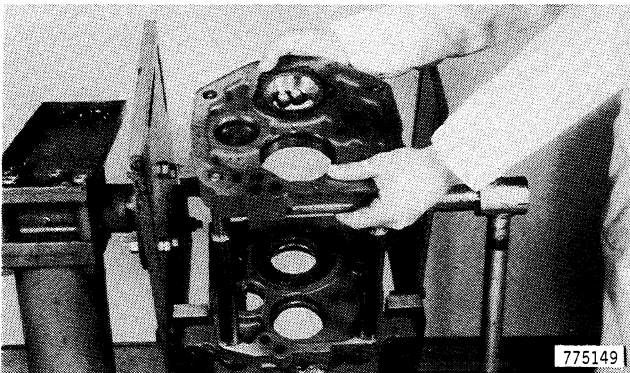

Figure 156

2. Install pinion shaft in housing, Figure 157.

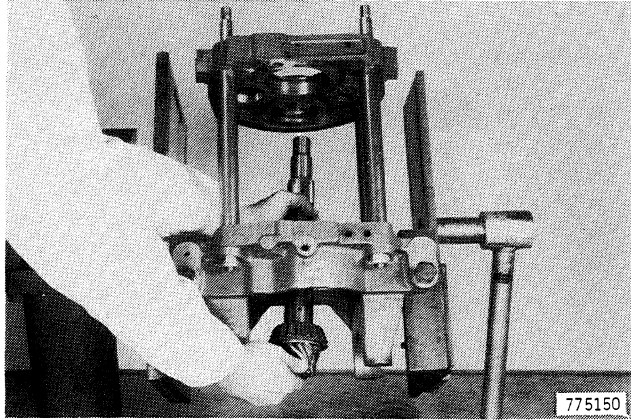

Figure 157

3. Install the shaft spacer, Figure 158.

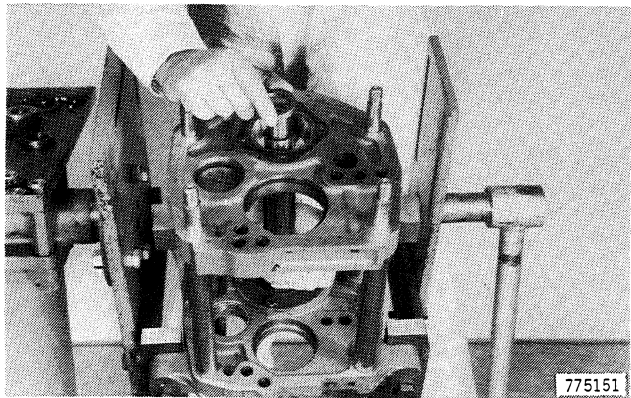

Figure 158

4. Install tapered roller bearing, Figure 159.

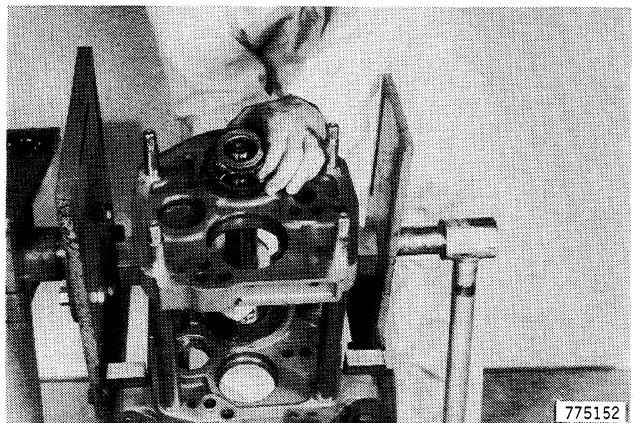

Figure 159

- 55. Turn adjusting nut on the side opposite the ring gear teeth in and the opposite nut out the same amount until clearance is between .007-.009 inch (0.17-0.22 mm), Figure 206.

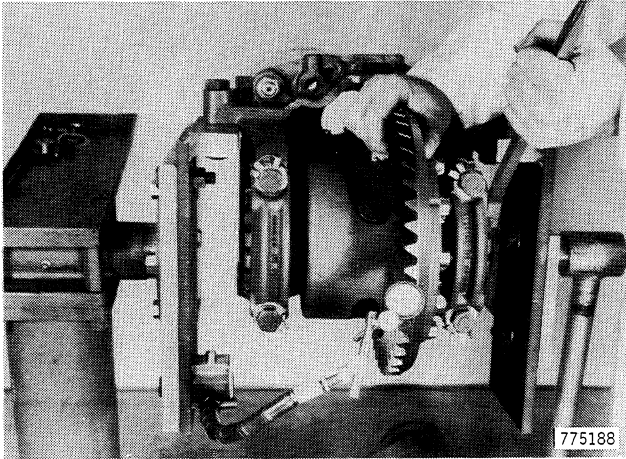

Figure 206

- 56. Install adjusting nut retaining clip, Figure 207. Tighten cap screw and bend tab against head.

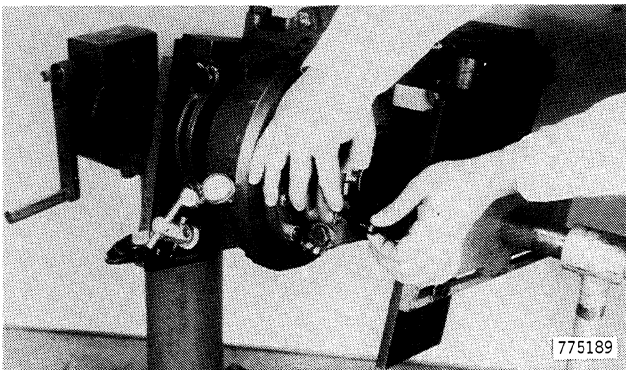

Figure 207

- 57. Repeat step 56 for opposite side.
- 58. Tighten differential cap retaining cap screws to 120 foot-pounds (163 N m), Figure 208.

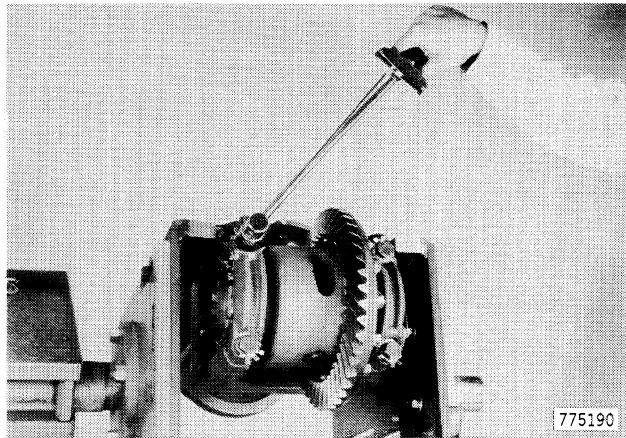

Figure 208

- 59. Bend tabs against differential cap retaining cap screws, Figure 209.

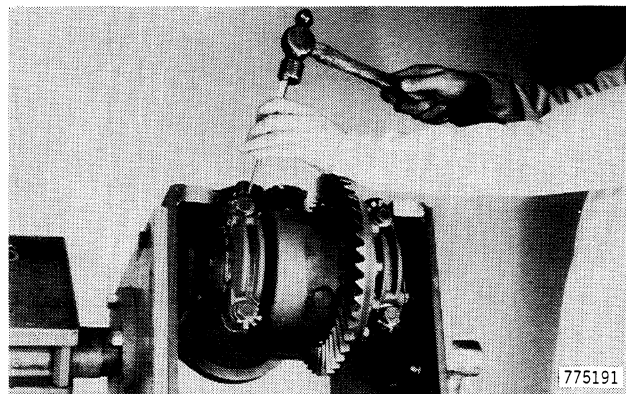

Figure 209

- 60. Apply oiled red lead or equivalent marking paste to several teeth of ring gear, Figure 210.

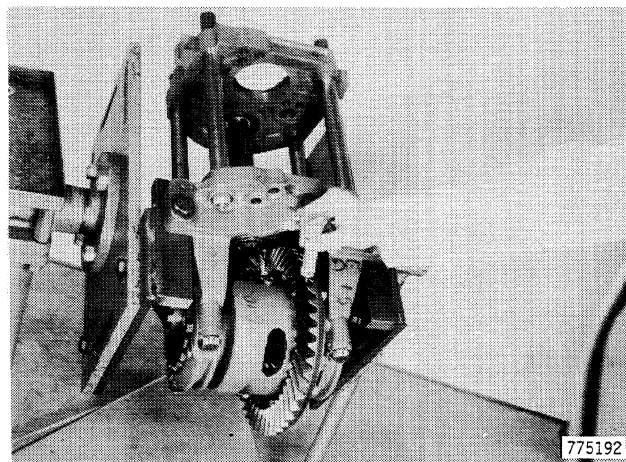

Figure 210

40. Remove self-locking nuts, Figure 254.

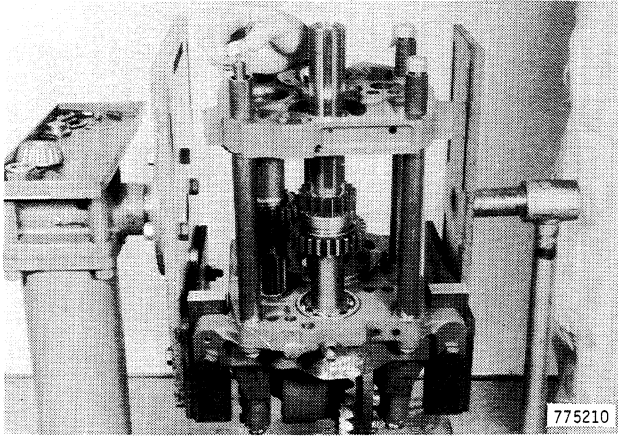

Figure 254

41. Remove spacers, Figure 255.

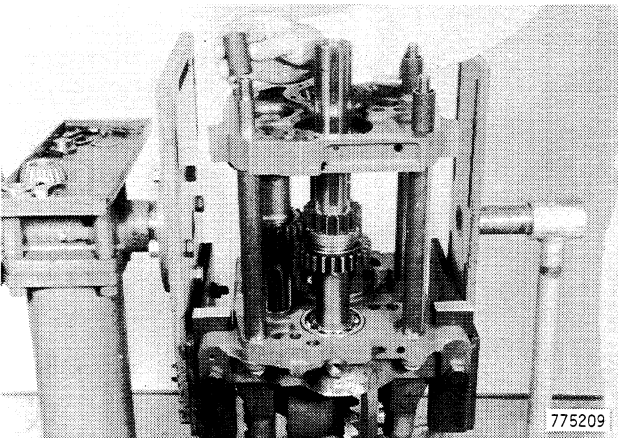

Figure 255

42. Remove stepped washer, shims and spacer, Figure 256.

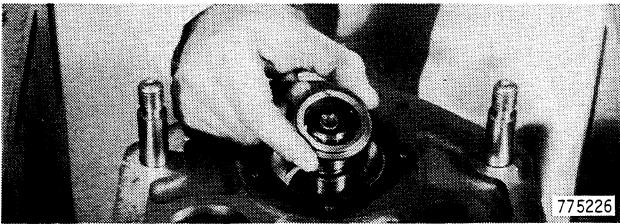

Figure 256

43. Remove separator plate, Figure 257.

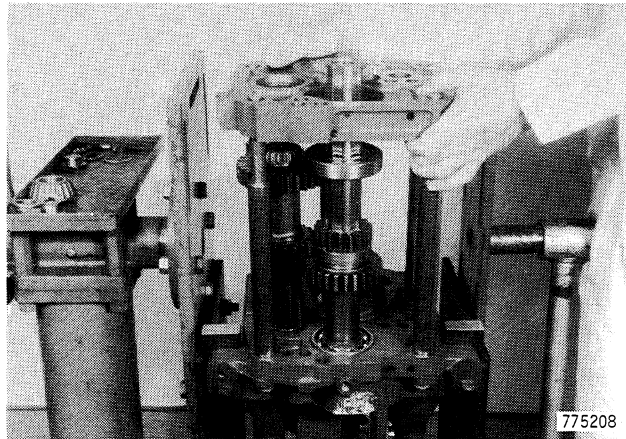

Figure 257

44. Remove input shaft, Figure 258.

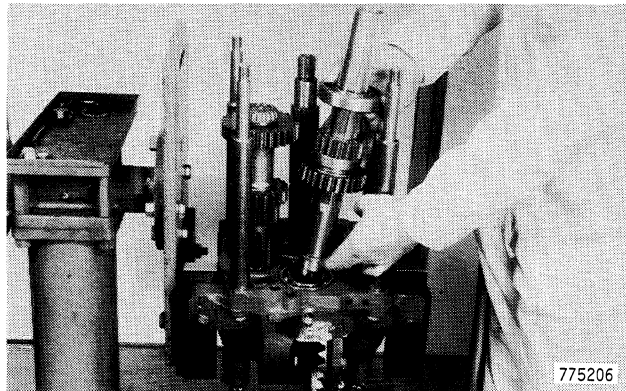

Figure 258

45. Remove bearing plate cap screws one at a time, Figure 259.

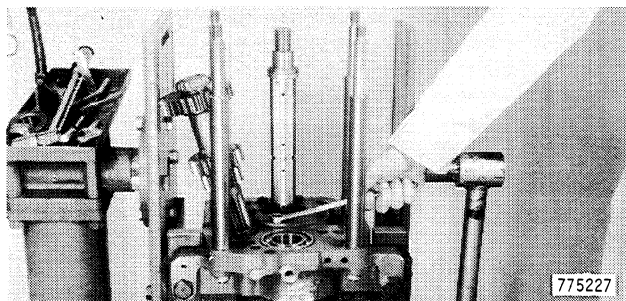

Figure 259

46. Apply Loctite 271 red to the cap screws, Figure 260.

14. Install counter gear assembly, Figure 312.

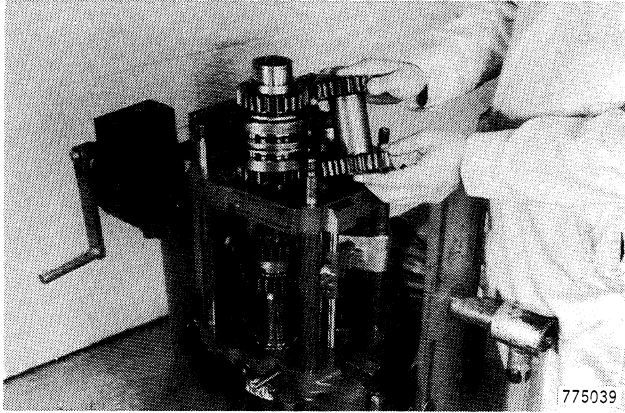

Figure 312

15. Place shuttle housing in position, being sure that all gear teeth are in alignment, Figure 313.

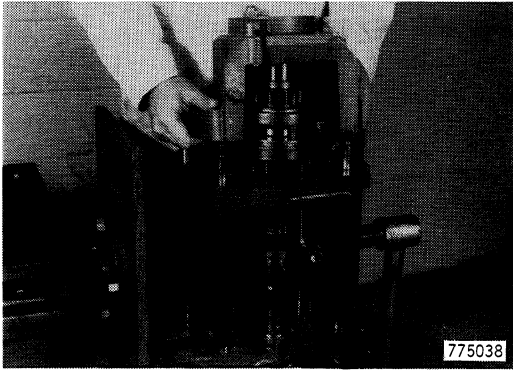

Figure 313

16. Install counter gear shaft, Figure 314.

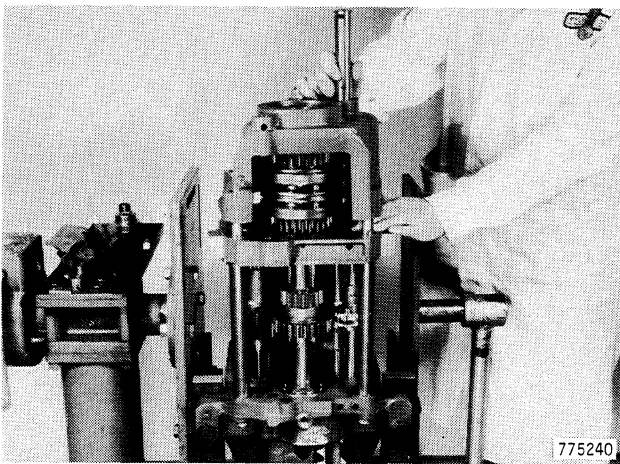

Figure 314

17. Install retaining plate, tab washer and cap screw, Figure 315.

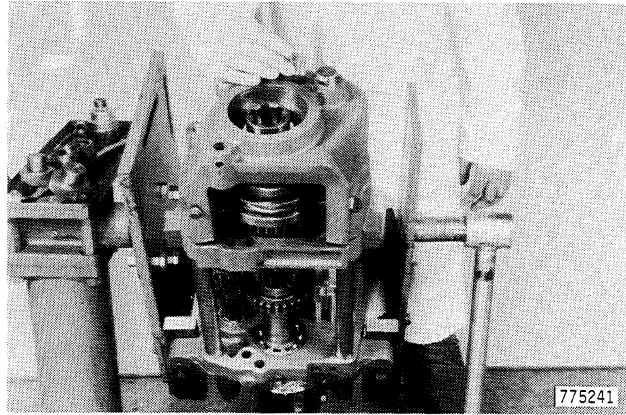

Figure 315

18. Align all gears and lower housing into position, Figure 316.

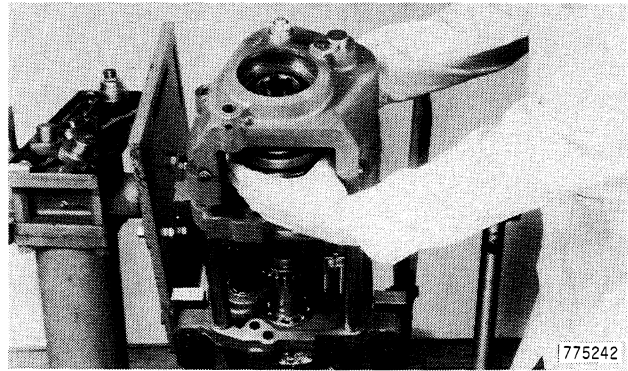

Figure 316

19. Place forward bearing in position, Figure 317.

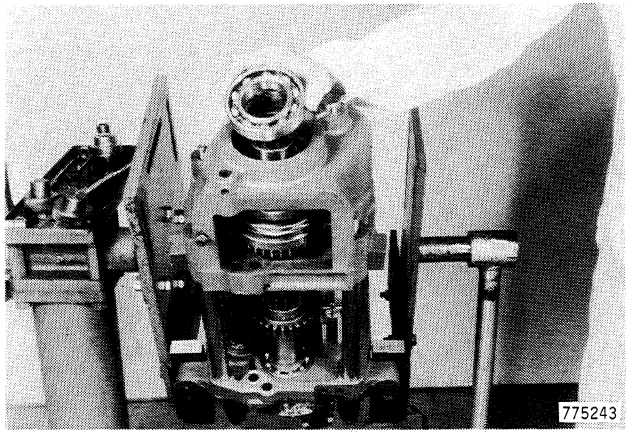

Figure 317

36. Raise tractor with a suitable lifting device and remove stands or blocks. Lower tractor to the floor.

37. Install ROPS using a chain hoist capable of lifting 1000 pounds (454 kg), Figure 360.

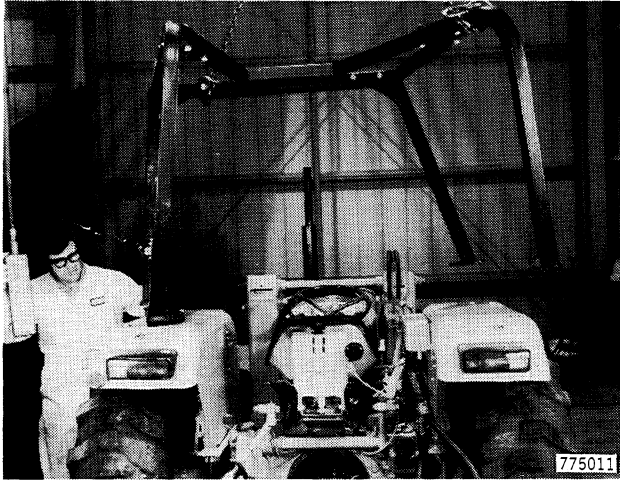

Figure 360

38. Install cap screws, flat washers and lock washers and tighten to 170 foot-pounds (231 N m), Figure 361.

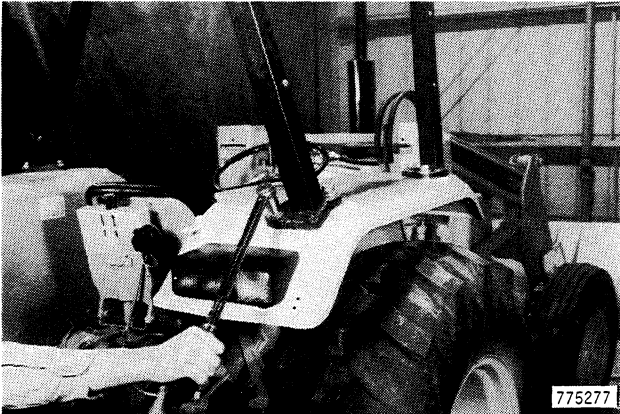

Figure 361

39. Install pump mounting plate using a new gasket, Figure 362.

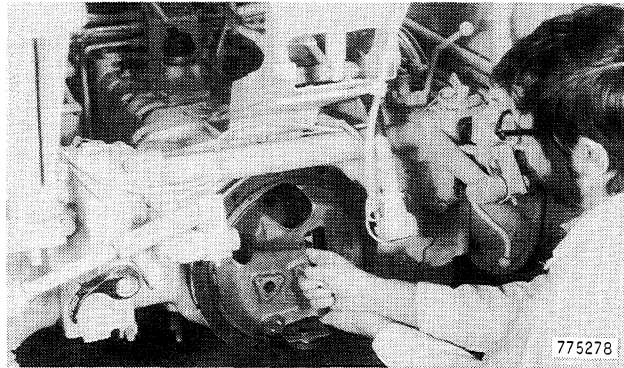
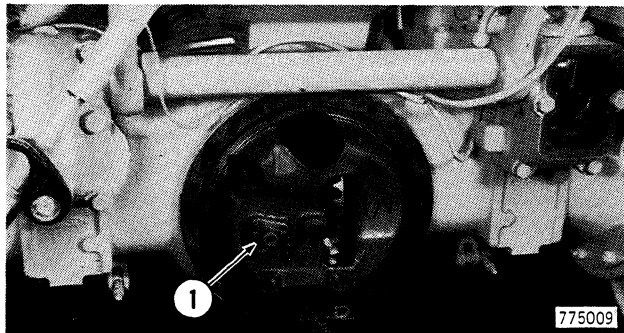

Figure 362

40. Install hydraulic pump outlet tube retaining plate, Figure 363. Install a new O-ring on pump outlet tube.



1. Retaining Plate

Figure 363

41. Install a new O-ring on pump inlet tube. Install selectamatic pump and secure tube clamp to top of pump, Figure 364.

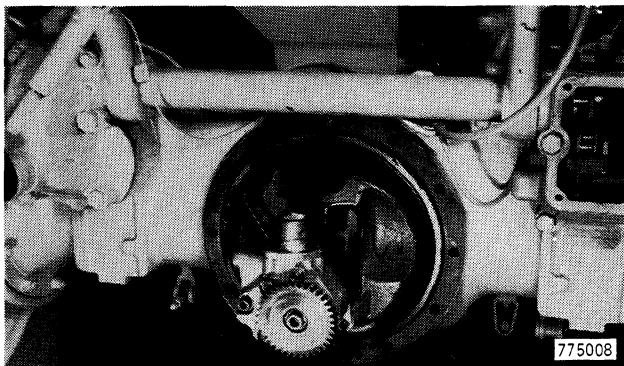

Figure 364

15. Remove inner seal, Figure 22.

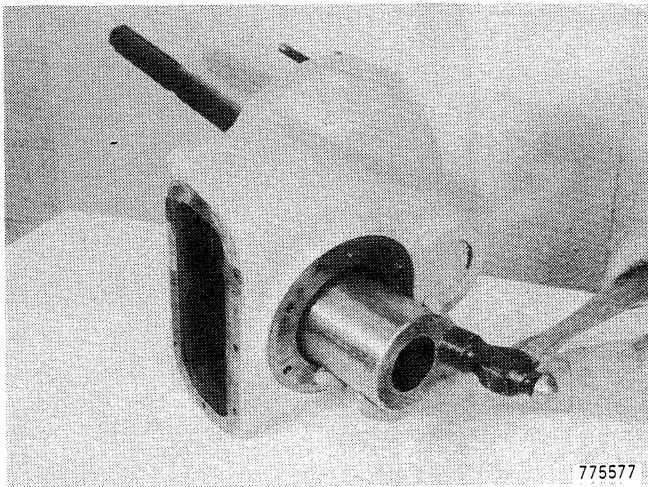

Figure 22

16. Using a suitable puller, remove inner bearing cup, Figure 23.

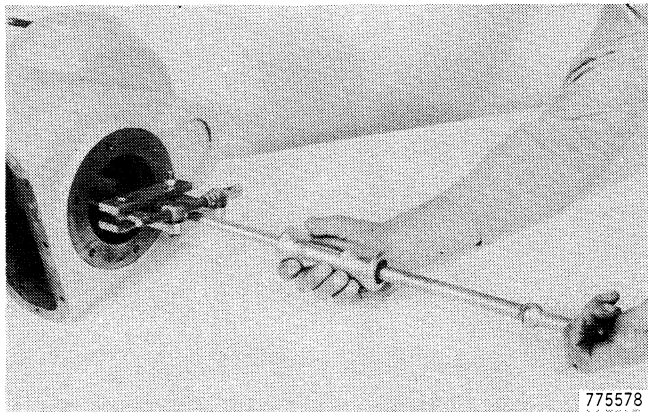

Figure 23

17. Remove brake drum using puller:

- a. Refer to page 6425-4 and install K960618 brake drum puller, Figure 24.

NOTE: Use 1/2 - 13 NC x 5 inches jack bolts (not supplied with tool).

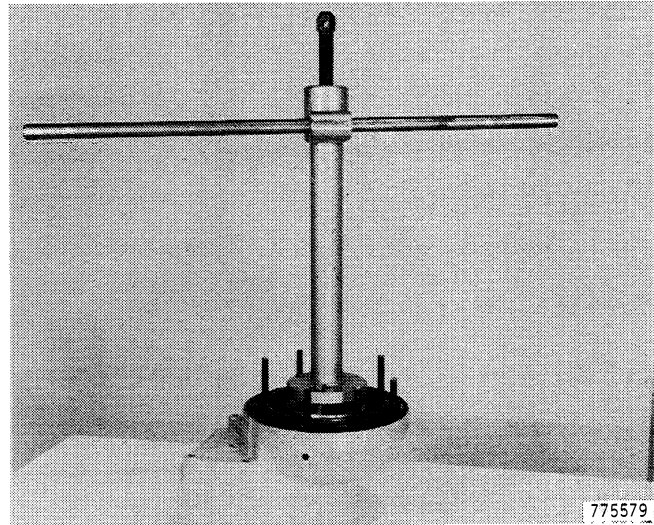

Figure 24

- b. Shop made puller can be used as shown in Figure 25.

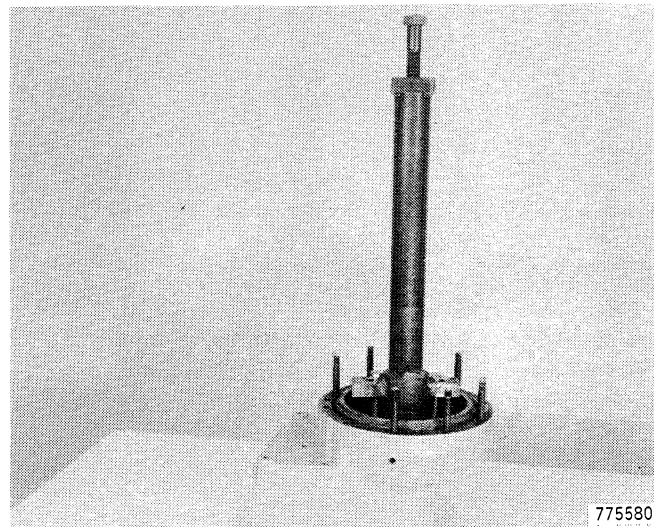

Figure 25

42. Install keys in axle shaft and install brake drum by driving it onto shaft with puller and heavy hammer, Figure 77.

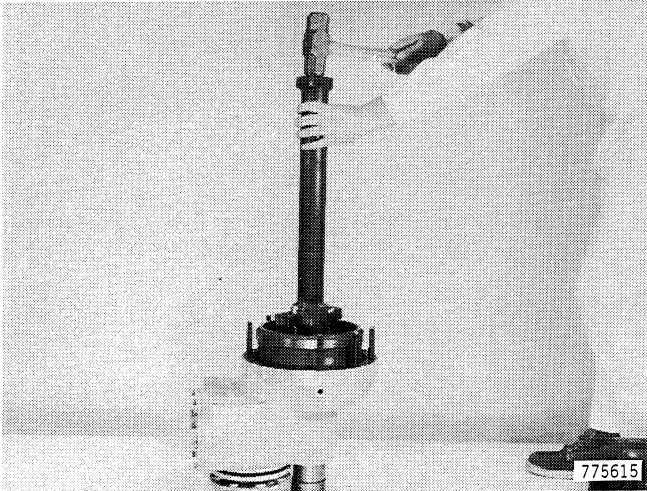

Figure 77

Installation

NOTE: Check the axle seal in the rear axle case before installing final drive. Replace if damaged.

1. Connect a hoist which has the ability to lift 1000 pounds (454 kg) to the final drive.
2. Lift the final drive and bring it into an alignment with the rear axle housing. Install final drive into the rear axle housing, Figure 78.

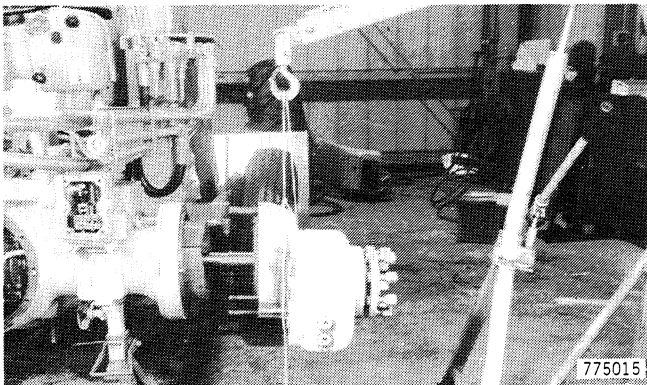

Figure 78

3. Install nuts and lock washers on studs. Tighten the nuts evenly to a torque of 75 foot-pounds (102 N m), Figure 79.

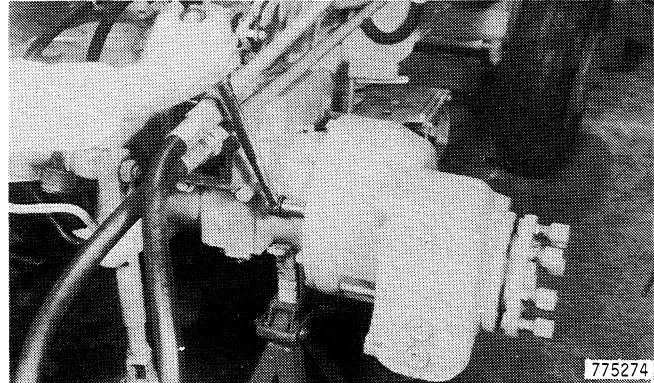

Figure 79

4. If right-hand final drive was removed, release differential lock pedal.
5. Install fender and connect light wires, Figure 80.

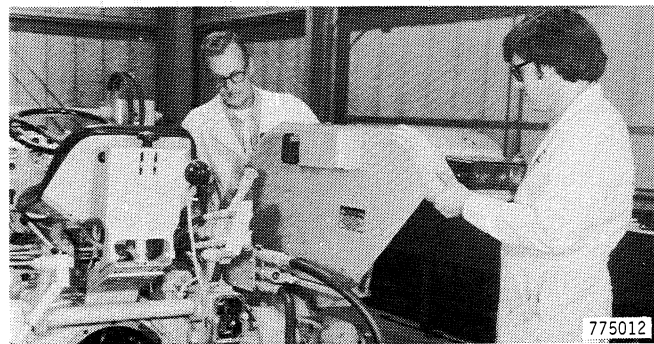

Figure 80

6. Install rear wheels and tighten the nuts to a torque of 120 foot-pounds (163 N m), Figure 81.

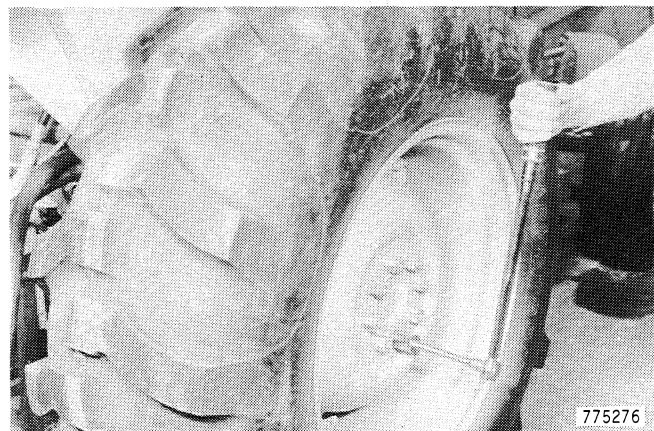

Figure 81

6. Remove shims from idler gear shaft, Figure 11.

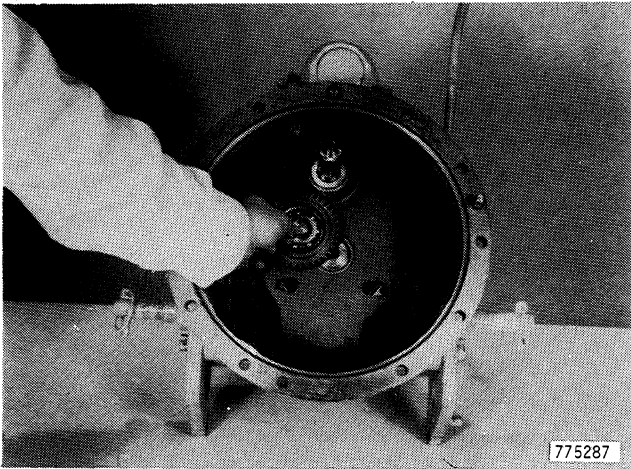

Figure 11

7. Remove idler gear, Figure 12.

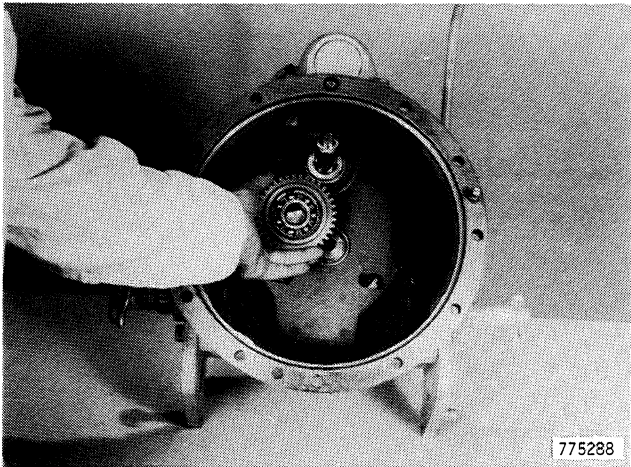

Figure 12

8. Lay idler gear on bench and remove one of the larger snap rings, Figure 13.



Figure 13

9. Turn gear over and tap ball bearing out with a soft hammer, Figure 14.

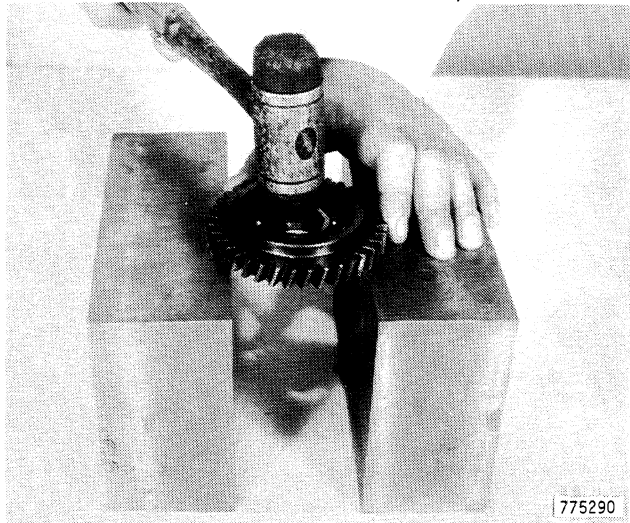

Figure 14

46. Remove shaft seal from cover plate, Figure 51.

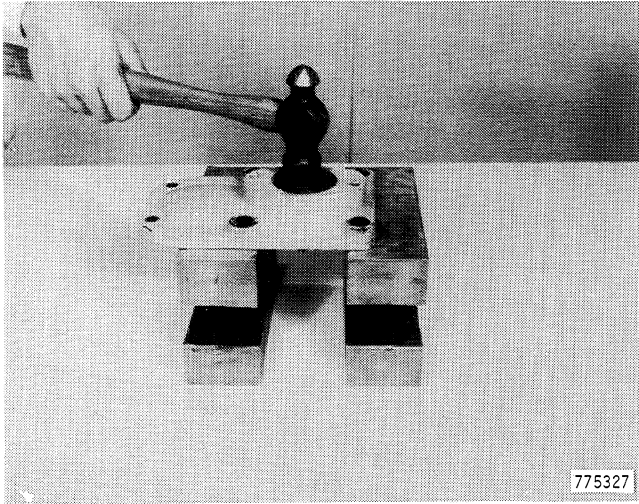

Figure 51

47. If needle bearings are to be replaced, drive bearings out of housing using a suitable driver, Figure 52.

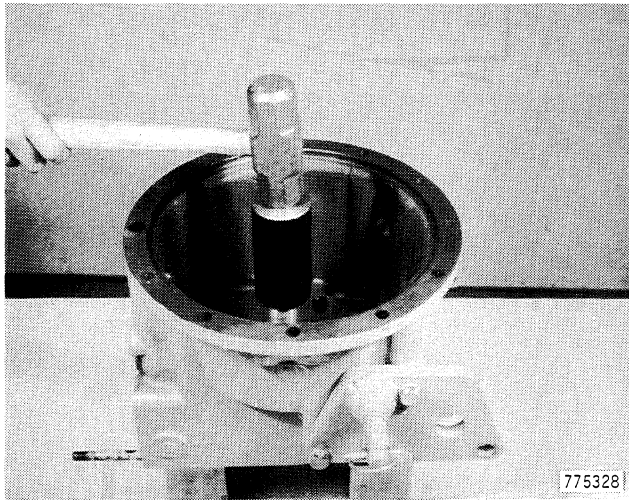

Figure 52

Assembly

1. Wash all parts in clean solvent and blow dry with moisture free compressed air.
2. If needle roller bearings were removed, place housing in a press and, using bearing tool shown on page 6431-3, press new bearings into housing, Figure 53. Press bearings flush with housing. Do not drive bearings into housing with a hammer; damage to needle bearing rollers will result.

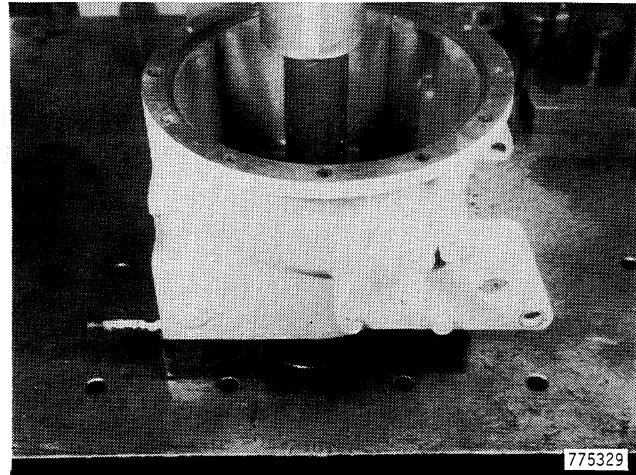

Figure 53

3. If idler shaft was removed, install new idler shaft, Figure 54.

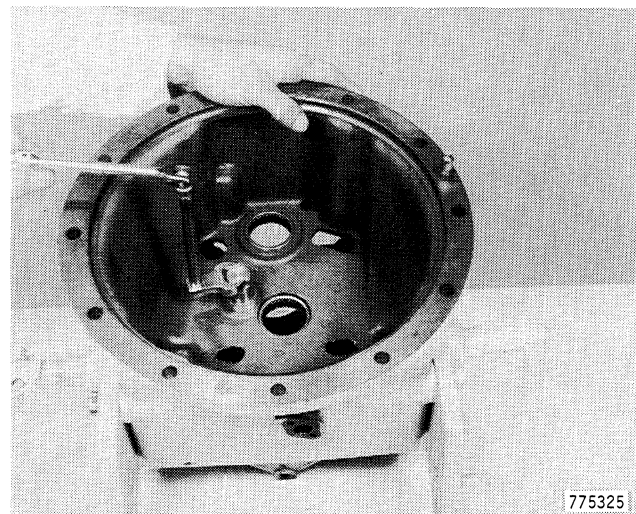

Figure 54

41. Install cap screw, Figure 91.

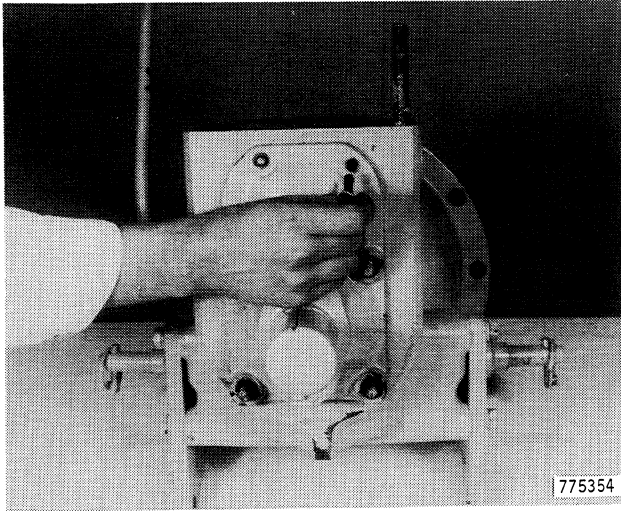

Figure 91

43. Install PTO guard, Figure 93.

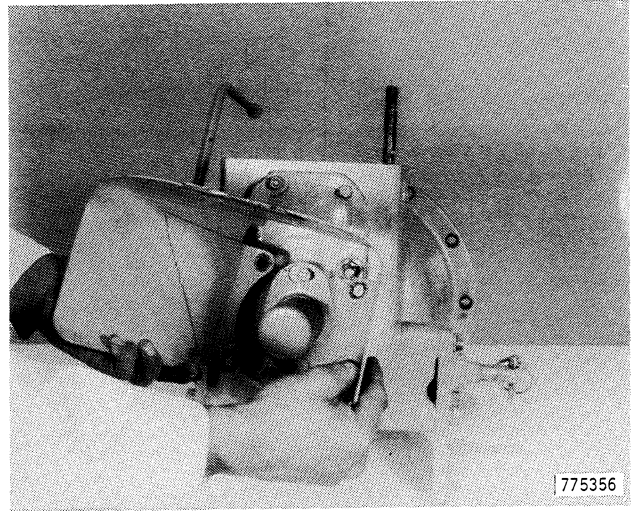

Figure 93

42. Install nut and new sealing washer, Figure 92.

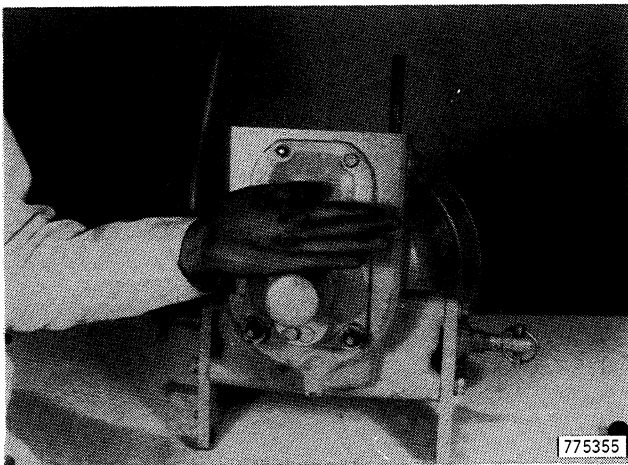

Figure 92

44. Install nuts and lock washers on PTO guard mounting studs, Figure 94.

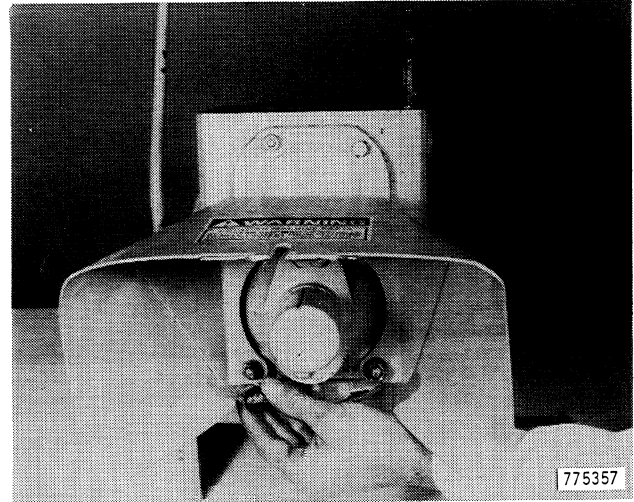

Figure 94

6. Remove shims from idler gear shaft, Figure 11.

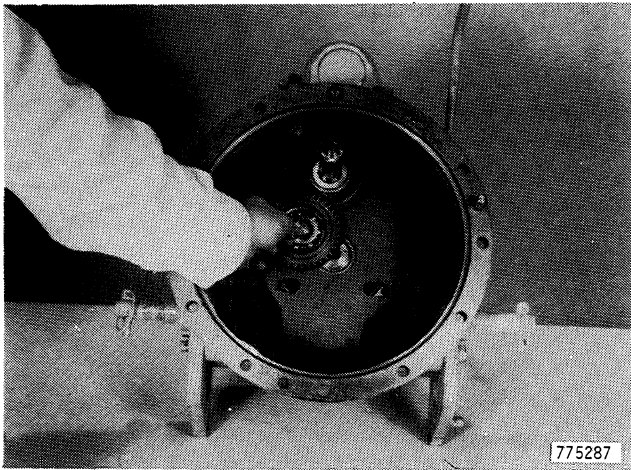

Figure 11

8. Lay idler gear on bench and remove one of the larger snap rings, Figure 13.



Figure 13

7. Remove idler gear, Figure 12.

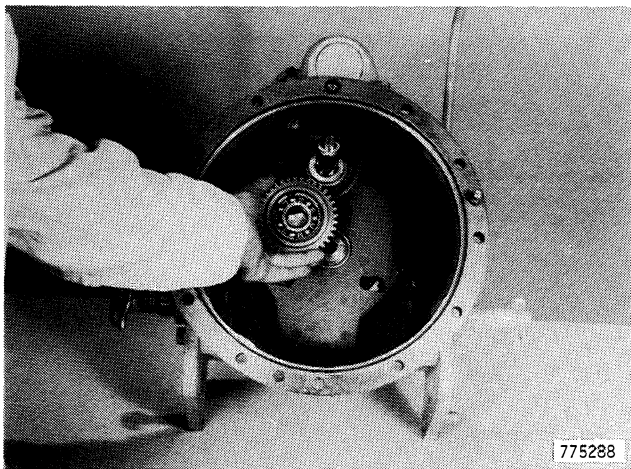

Figure 12

9. Turn gear over and tap ball bearing out with a soft hammer, Figure 14.

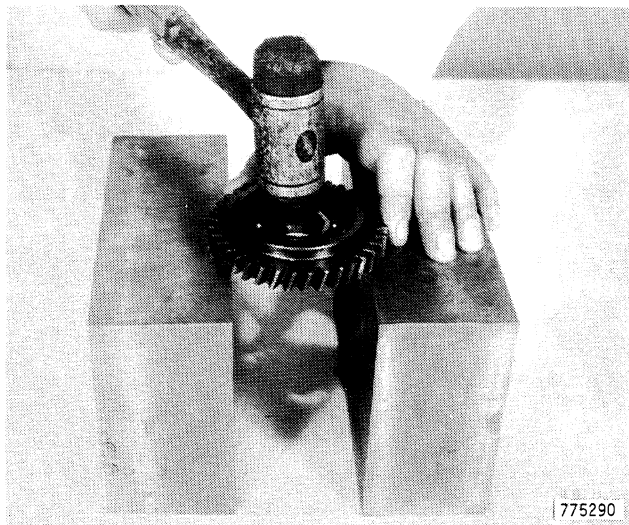

Figure 14

46. Remove shaft seal from cover plate, Figure 51.

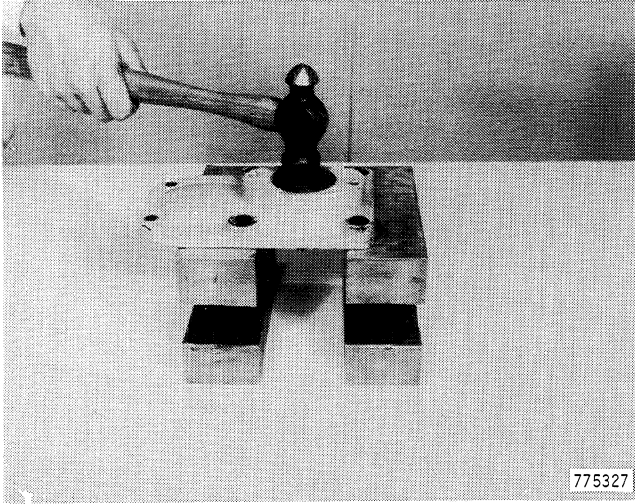

Figure 51

47. If needle bearings are to be replaced, drive bearings out of housing using a suitable driver, Figure 52.

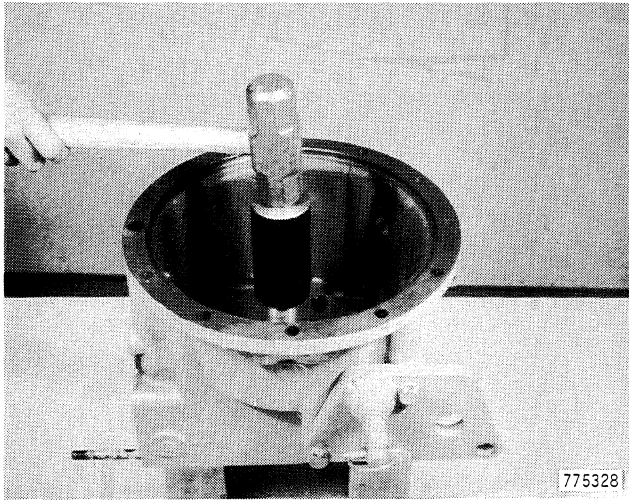

Figure 52

Assembly

1. Wash all parts in clean solvent and blow dry with moisture free compressed air.
2. If needle roller bearings were removed, place housing in a press and, using bearing tool shown on page 6431-3, press new bearings into housing, Figure 53. Press bearings flush with housing. Do not drive bearings into housing with a hammer; damage to needle bearing rollers will result.

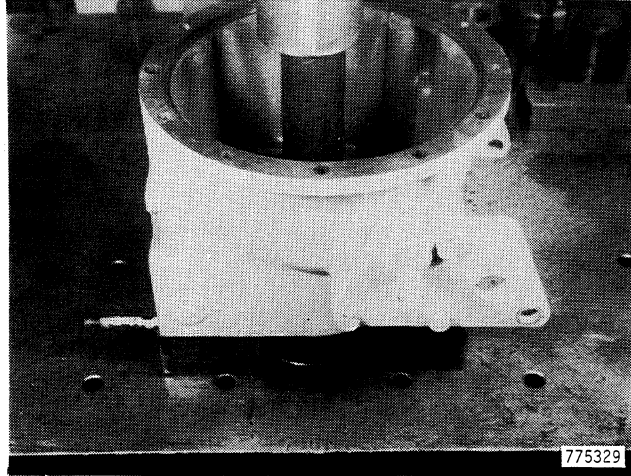

Figure 53

3. If idler shaft was removed, install new idler shaft, Figure 54.

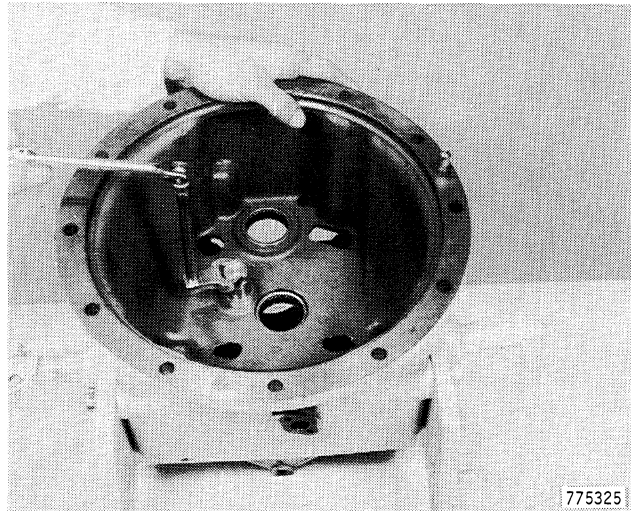

Figure 54

41. Install cap screw, Figure 91.

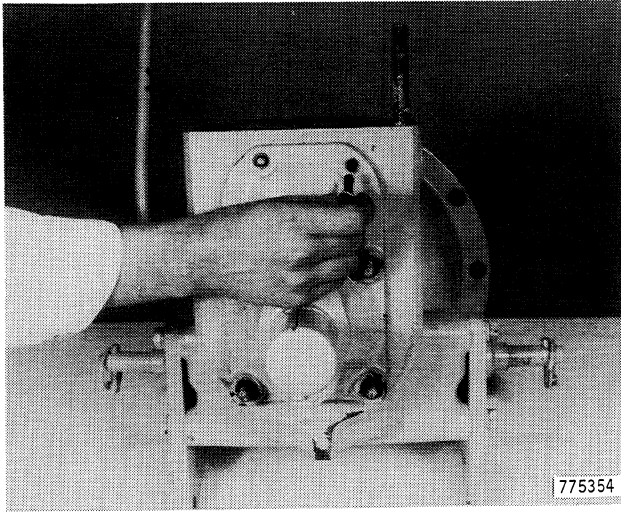

Figure 91

43. Install PTO guard, Figure 93.

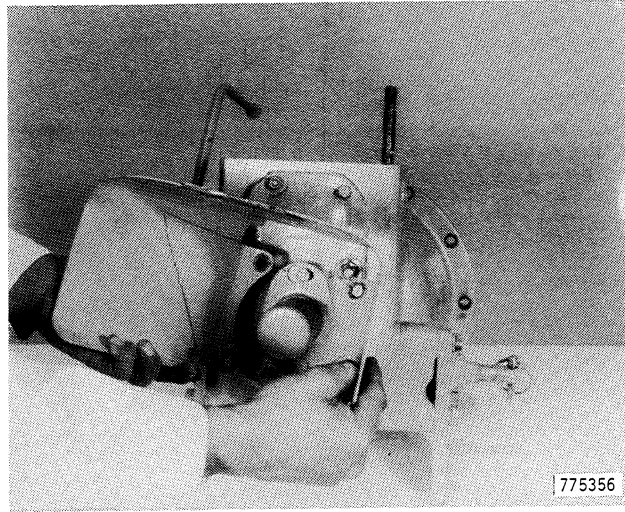

Figure 93

42. Install nut and new sealing washer, Figure 92.

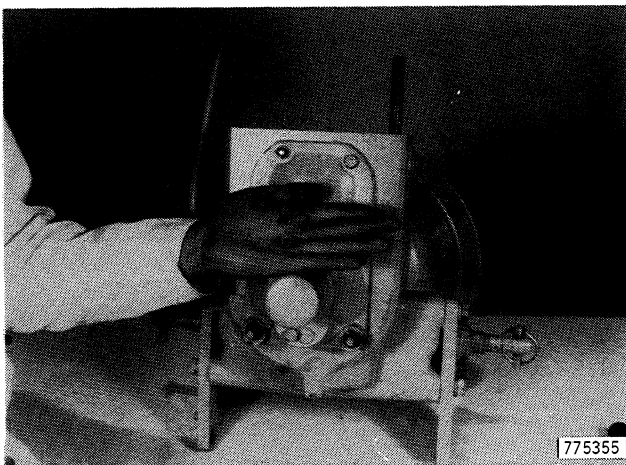

Figure 92

44. Install nuts and lock washers on PTO guard mounting studs, Figure 94.

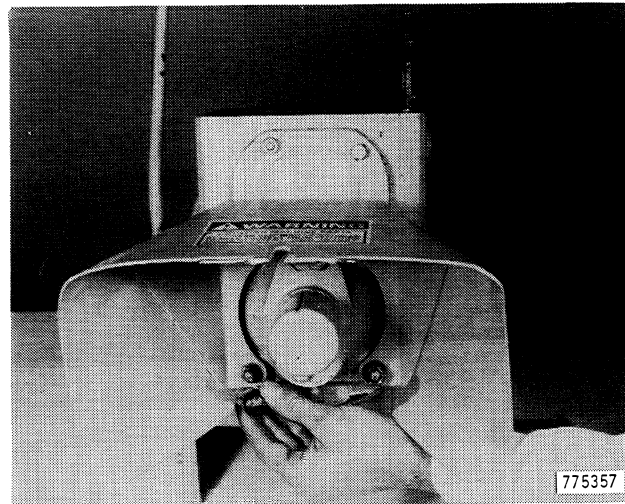

Figure 94

12. Put the loader strut rods over the pin in the draw-bar and install the flat washers and cotter pins.
13. Tighten the rear nuts on the strut rods to a torque of 15-20 foot-pounds (20-27 N m).
14. Tighten the front nuts on the strut rods to a torque of 100-120 foot-pounds (135-163 N m).
15. Fill the rear axle housing with oil specified in Section 1050.
16. Adjust the brakes. See below.
17. If the machine is equipped with a backhoe, install backhoe. See Section 9100.

BRAKE ADJUSTMENT

1. Use a jack and lift the tractor until the rear wheels are above the ground. Put a stand under the rear axle housing to hold tractor in position.
2. Lock the two brake pedals together.
3. Put the gear shift levers in the Neutral position.
4. Loosen the lock nut and tighten the nut on the left-hand brake rod until the left-hand wheel can not be turned by hand.
5. Loosen the nut on the left-hand brake rod until the left-hand wheel can be turned freely by hand.
6. Engage the park brake until the left-hand wheel can just be turned by hand.
7. Loosen the lock nut and tighten the nut on the right-hand brake rod until the right-hand wheel can just be turned by hand.
8. Turn both rear wheels by hand to be sure that both the left-hand and the right-hand brakes are adjusted evenly. Tighten the lock nuts.
9. Use a jack and lift the tractor until the stand can be removed from under the rear axle housing. Pull the stand out from under the tractor.
10. Lower the tractor to the ground.
11. Operate the machine. Check the operation of the brakes. The brakes must engage evenly without binding or overheating.

TROUBLE SHOOTING

Problem: Poor Operation of a Single Circuit Only

If only one circuit is performing poorly the problem is in that circuit. Possible causes are worn cylinder packing, secondary relief valve (if used) setting to low or leaking, leaking load check valve or worn spool or spool bore.

CHECK	DETAILED INSTRUCTIONS
<p>1. Check cylinder packing.</p> <p>a. Loader lift cylinder.</p> <p>b. Loader bucket cylinder.</p> <p>c. Backhoe boom cylinder.</p> <p>d. Backhoe dipper cylinder.</p> <p>e. Backhoe bucket cylinder.</p> <p>f. Backhoe swing cylinder.</p> <p>g. Backhoe stabilizer cylinder</p>	<p>a. Raise loader arm to full height and block in place. Disconnect tube at rod end of each cylinder and loosen clamp and slide tube away from fitting. Start engine and run at full throttle. Move control lever to the Raise position, hold in place and check for leakage at each cylinder. Any leakage indicates worn packing and repair of that cylinder. Checking leakage in the opposite direction cannot be done unless the pistons are prevented from bottoming in the cylinder. In almost all cases, leakage in one direction will result in leakage in the opposite direction.</p> <p>b. Raise loader arm, completely dump the bucket and rest bucket on the floor. Disconnect hose at rod end of each cylinder. Start engine and run at full throttle. Move control lever to the Dump position, hold in place and check for leakage. Any leakage indicates worn packing and repair of that cylinder. Leakage in one direction usually results in the opposite direction.</p> <p>c. Raise the backhoe boom and block in position. Disconnect the hose at the closed end of the boom cylinder. Start the engine and run at full throttle. Hold the control lever to raise the boom and check for leakage. Any leakage indicates worn packing and repair of that cylinder.</p> <p>d. Raise the backhoe boom and completely extend the dipper cylinder and block in position. Disconnect the hose at the rod end of the cylinder. Start the engine and run at full throttle. Hold the control lever in the In position and check for leakage. Any leakage indicates worn packing and cylinder repair.</p> <p>e. Completely extend the bucket cylinder. Disconnect the hose at the rod end of the bucket cylinder. Start the engine and run at full throttle. Hold the control lever in the Curl position and check for leakage. Any leakage indicates worn packing and cylinder repair.</p> <p>f. Swing the backhoe all the way to the left. Start the engine and run at full throttle. Hold the control lever in the Left position and check for leakage out of the left-hand swing cylinder breather. Any leakage indicates worn packing and cylinder repair. Swing the backhoe all the way to the right. Start the engine and run at full throttle. Hold the control lever in the Right position and check for leakage out of the right-hand swing cylinder breather. Any leakage indicates worn packing and repair of the cylinder.</p> <p>g. Block up the rear of the machine so the stabilizer can be completely lowered without touching the floor. Disconnect the line to the rod end of the cylinder. Start the engine and run at full throttle. Hold the control lever in the Down position and check for leakage. Any leakage indicates worn packing and repair of that cylinder.</p>

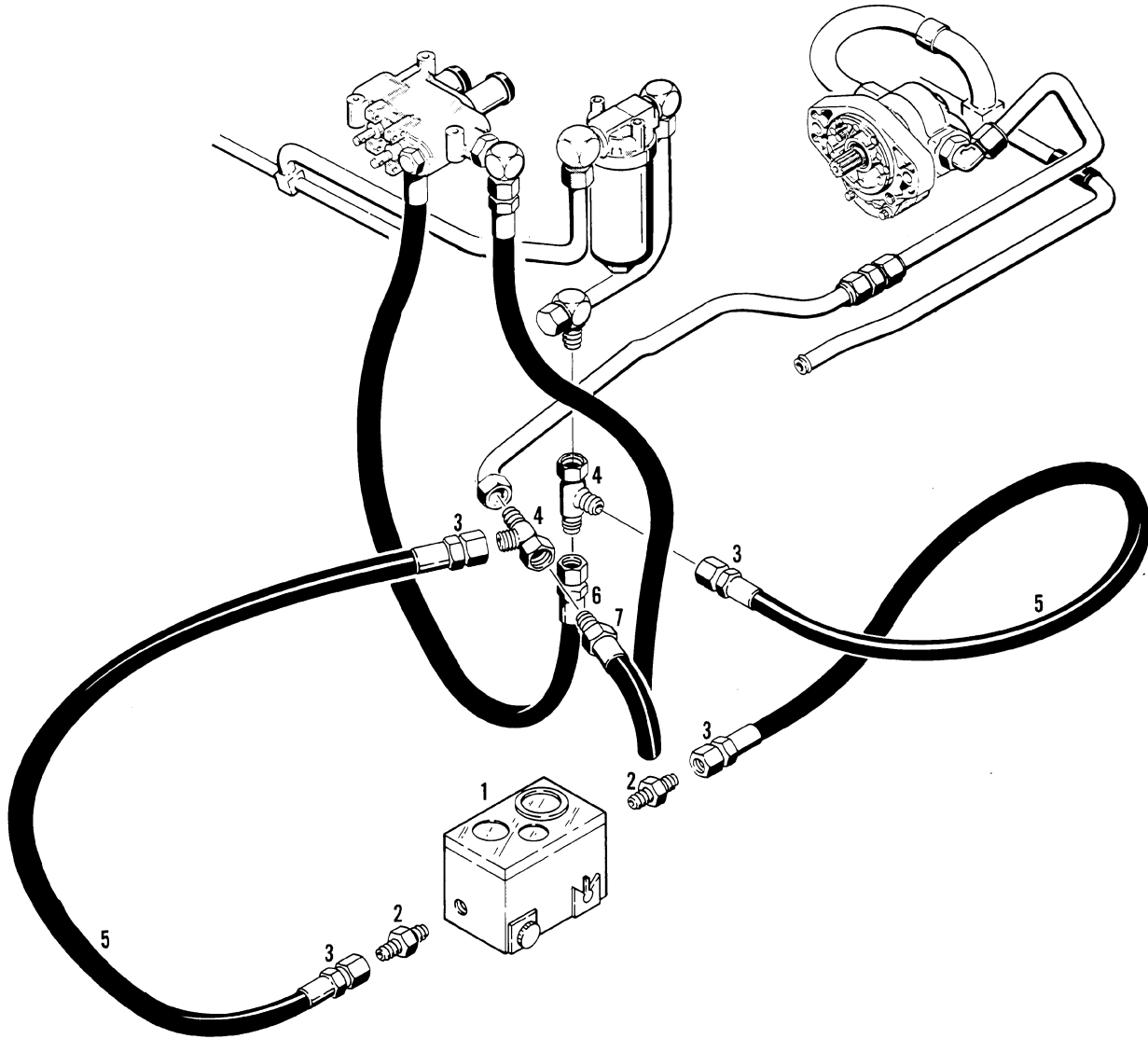

770219

REF.	PART NO.	DESCRIPTION	REQ'D
1.		FLOWMETER	1
2.	218-466	3/4 NPT TO 1-1/16-12 JIC ADAPTER	2
3.	218-206	1-1/16-12 JIC SWIVEL FITTING	4
4.	218-5221	1-1/16-12 JIC SWIVEL TEE	2
5.		3/4 I.D. DOUBLE BRAID HOSE. CUT TO 8 FOOT LENGTH OR AS DESIRED.	2
6.		DISCONNECT HOSE AND CONNECT FLOWMETER OUTLET	
7.		DISCONNECT HOSE AND CONNECT FLOWMETER INLET	

Figure 11

SECONDARY RELIEF VALVE ADJUSTMENT

The secondary relief valves on this machine are nonadjustable and nonrepairable. If a relief valve does not relieve at the specified pressure, it must be replaced.

LOADER MAIN RELIEF VALVE

Adjustment

Models With Single Reservoir

The main relief valve is nonadjustable and non-repairable. If the relief valve does not relieve at the specified pressure, it must be replaced.

Models With Dual Reservoirs

1. Remove accumulated dirt from main relief valve and surrounding area. The relief valve is located at the spool end of the control valve next to the lift spool.
2. Remove the small hex cap. The large hex is the relief valve body.
3. Remove the spring and poppet from the valve body. The poppet is held by the fit of a sealing ring. Check the condition of the sealing ring and replace as required.
4. Add shims to poppet stem to increase pressure setting or remove shims to decrease pressure setting. Shims are available in .010, .020 and .040 inch (0.254, 0.508 and 1.016 mm) thicknesses.
5. Install poppet, spring and cap and check pressure setting again.

Pressure Check

1. The hydraulic oil must be warm 120° F. (49° C.) or control valve inlet hose must be very warm to the touch. To warm the oil, hold the control lever in Rollback for 15 seconds, then return the control lever to Neutral for 30 seconds. Repeat this cycle until oil temperature is as specified.
2. Rest Loader bucket flat on the floor.
3. Drill and tap a cap nut, part number 218-335 to connect your pressure gauge into the hydraulic system. The gauge must register 3000 psi (20 680 kPa) and the hose must be long enough so the gauge can be viewed from the operators seat.
4. Install a tee, part number 218-5221 between the pump outlet tube and the backhoe inlet hose on backhoe models or the loader valve inlet hose on loader only machines.
5. Install the drilled cap to tee and connect the gauge to cap.
6. Start the engine and run at full throttle. Hold the loader bucket control lever in Rollback position and observe the pressure gauge. The pressure gauge must indicate 1750 ± 50 psi (12 066 ± 344 kPa).

5. If the pump has been disassembled because of low output and the pump body and gears are found to be serviceable, it can be assumed that the seal package is probably defective, requiring end cover replacement.
6. Inspect the pressure plate for scoring, pitting and excessive wear.

Assembly

1. Position gears in body as shown in Figure 11. The check valve spring in the driven gear must be up.

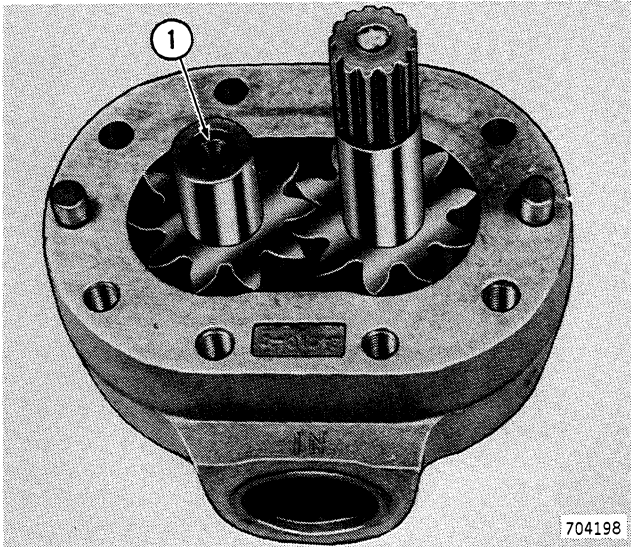

1. CHECK VALVE SPRING UP

Figure 11 - Installing Gears

2. If the shaft seal was removed, press in a new seal. The seal must be square to the bushing within .002 inch (.051 mm) and pressed in .010 inch (.254 mm) - .020 inch (.508 mm) below the edge of the seal bore.
3. Coat the smooth side of the pressure plate with a light, clean grease and position on end cover as shown in Figure 6. Then coat the O-ring with grease and position in groove formed by the pressure plate and end cover.
4. Set body on work bench with gears up and install end cover over gears being careful not to damage the shaft seal. When end cover starts on dowel pins invert the pump and set the pump on open jaws of vise. Strike the body with a soft hammer until the body is seated against the end cover.

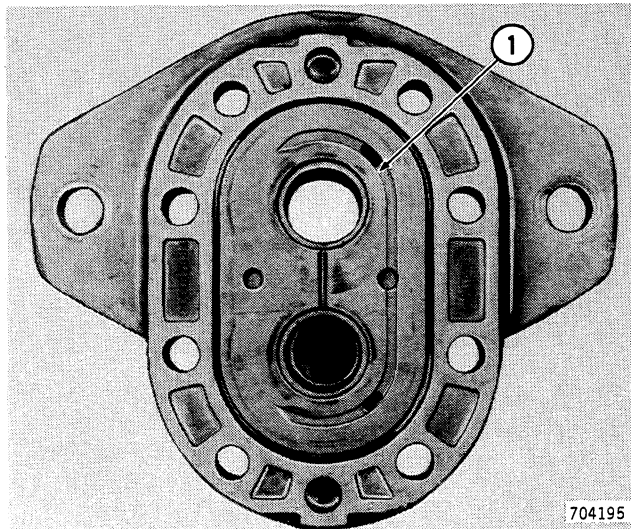

1. PRESSURE PLATE MUST BE INSTALLED AS SHOWN

Figure 12 - Pressure Plate Installed

5. Secure the end cover to the body with the eight ferry head bolts (four long and four short). Torque the bolts evenly to 25-35 foot-pounds (33-47 N m). Torque bolts in sequence as shown in Figure 13.

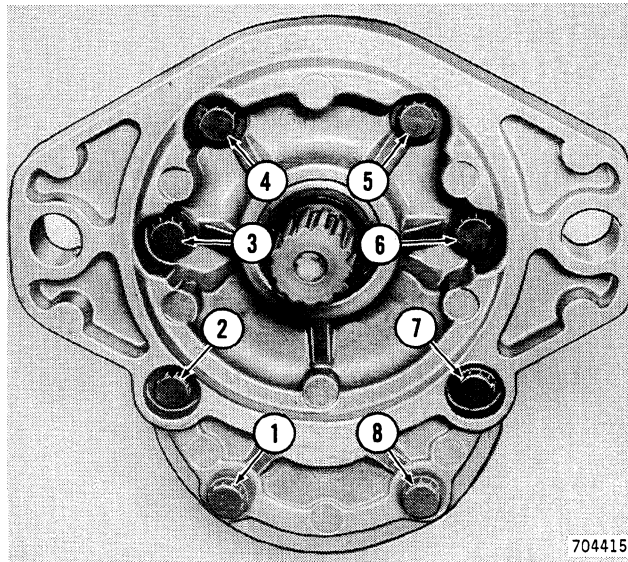
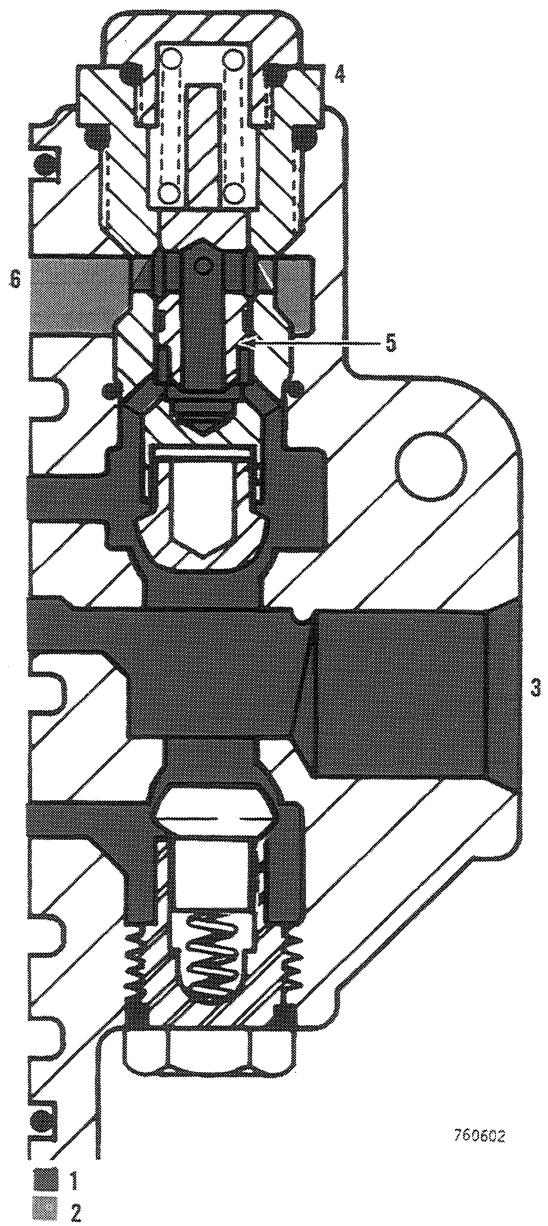

Figure 13 - Torque Sequence



- 1. PUMP FLOW
- 2. RETURN OIL
- 3. INLET PORT
- 4. MAIN RELIEF VALVE
- 5. RELIEF VALVE POPPET
- 6. RETURN PASSAGE

Figure 2 - Main Relief Valve Operation

Operation

General

The loader control valve is a two-spool, series-open center valve mounted on the right-hand side of the loader frame.

The lift spool is a four-position spool as follows: power in, power out, float, and neutral.

The bucket spool is a three position spool as follows: power in, power out, and neutral.

A nonadjustable, pilot operated relief valve at the control valve inlet prevents excessive pressure in the hydraulic system whenever a valve spool is actuated.

Load check valves are located between the work ports and spools to prevent reverse flow of oil as a spool is moved into a power position from neutral.

The valve is not equipped with overload (secondary) relief valves.

Oil Flow, Spools in Neutral

With the control valve spools in Neutral, oil flows from the inlet straight through the open center passage to the outlet as shown in Figure 6.

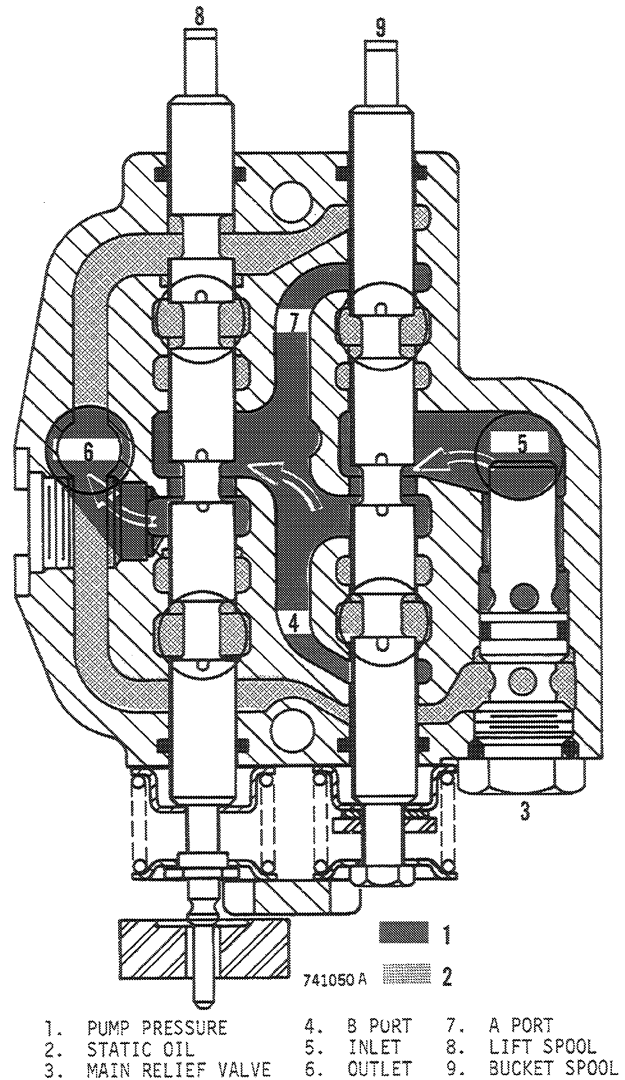

Figure 6 - Oil Flow, Spools in Neutral

TABLE OF CONTENTS

Specifications	8034- 3
Special Tools	8034- 3
Operation	8034- 5
Description of Components	8034- 5
Controls	8034- 5
Diagram: Three Point Hitch Hydraulic System	8034- 7
Diagram: Oil Flow to Raise Three Point Hitch	8034- 8
Diagram: Oil Flow to Hold Three Point Hitch	8034- 8
Diagram: Oil Flow to Lower Three Point Hitch	8034- 9
Diagram: Rear Auxiliary Control Valve and Remote Cylinder	8034-10
Diagram: Three Way Control Valve and Remote Cylinder	8034-11
Hydraulic Reservoir and Filter Service	8034-12
* Trouble Shooting	8034-13
Trouble Shooting Charts	8034-13
Testing the Hydraulic Pump	8034-15
Testing the Three Point Hitch Control Valve	8034-15
Adjusting the Selectamatic System	8034-17

Servicing Components

Hydraulic Pump	8034-21
Three Point Hitch Control Valve	8034-24
Control Mechanism	8034-29
Ram Cylinder	8034-30
Top Link Sensing Unit	8034-34
Three Way Control Valve	8034-36
Rear Auxiliary Control Valve	8034-37

HYDRAULIC RESERVOIR AND FILTER SERVICE

Transmission and Selectamatic System Hydraulic Oil Filter

The transmission filter element must be changed after the first 50 hours and every 500 hours thereafter. Also change the element when the yellow warning light on the instrument panel remains lit after the machine has run for 30 minutes at 1800 rpm (r/min).

1. Remove the plug and drain the transmission oil.

NOTE: The transmission oil must be changed after every 1000 hours. If the oil drained from the transmission is to be used again, drain into a clean container and cover while servicing the filter.

2. Remove the housing cap screws and the filter housing.
3. Remove the bypass filter assembly and the filter element. Discard the element.
4. Clean the bypass filter assembly in clean solvent and blow dry with moisture free compressed air. Make sure the wire screen is thoroughly clean.
5. Install filter element and the bypass filter assembly.
6. Install a new gasket on the filter housing and install the filter housing.
7. Be sure that the drain plug is installed and fill transmission with approximately 6 U.S. gallons (22.7 litres) of the oil specified in Section 1050. If the oil that was drained from the transmission is to be used again, filter it before it is put in the transmission.

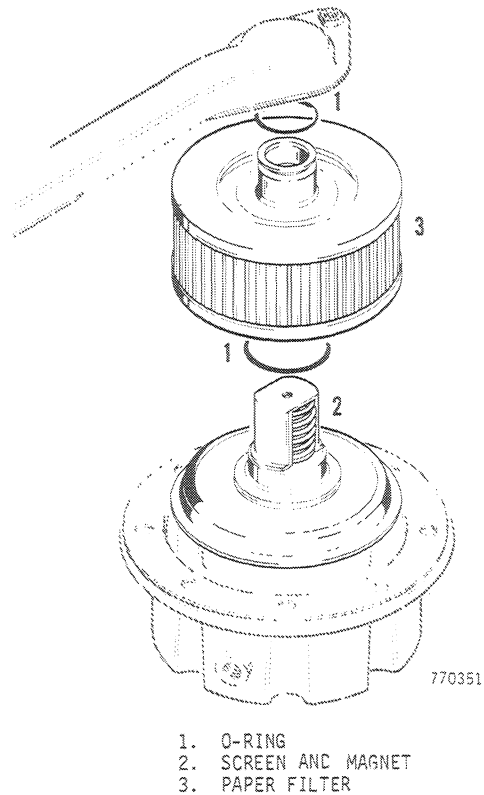

Figure 11 - Oil Filter

Oil Level Check

Check the transmission oil level every 10 hours or daily. The dipstick is located in the operator's compartment. Oil level is checked with the engine stopped. Oil level must be between the marks on the dipstick.

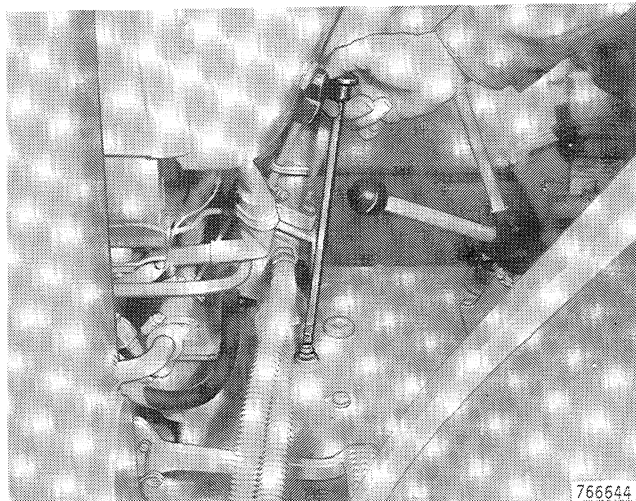

Figure 12 - Dipstick Location

Adjustment No. 7 Sensing Unit Cable

For this setting it is necessary to have weight on the lower links but the top link disconnected, so that no compression or tension load is applied to the response unit.

With weight on the lower links and the top link disconnected, plate selector knob in the Depth control position. After releasing the locknut, screw the cable adjuster (3) fully inwards to ensure that there is slackness in the cable. Move control lever (1) rearwards until it touches the quadrant spring and start the engine. Allow linkage to rise to full height and reach the Hold position then stop the engine. With control lever touching quadrant spring (4), screw the adjuster (3) outwards until the linkage commences to creep down then screw the adjuster inwards nine-and-a-quarter turns. Hold the adjuster stationary and tighten the locknut.

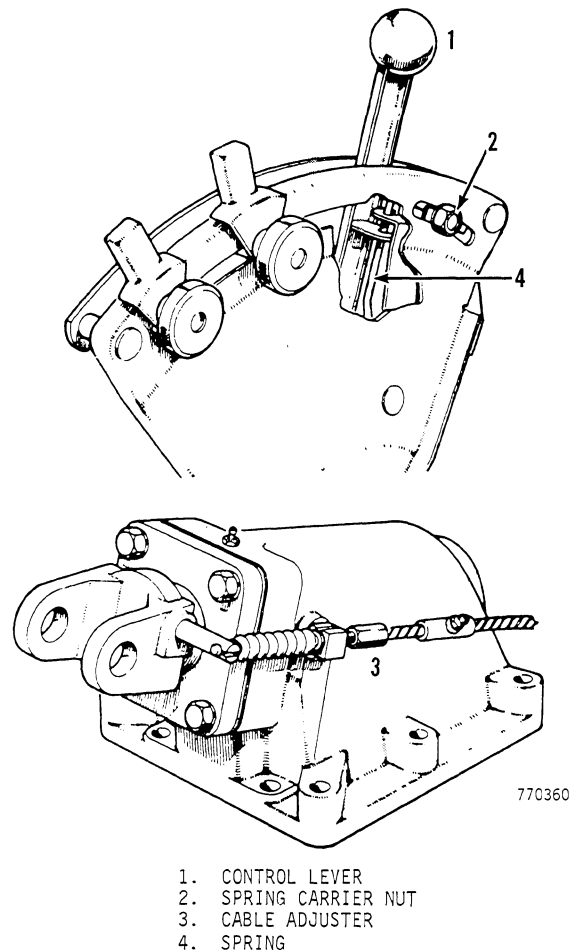

Figure 22 - Setting the Sensing Unit Cable

HYDRAULIC PUMP

General

The hydraulic pump consists of a body which houses the two gears. The gears are supported by bushings which not only provide bearings for the gear shafts but also seal the side faces of the gears against oil leakage. Most of the leakage which takes place in the gear type pump is through the clearance between gear side faces and the shaft bushings. The bushings are therefore pressure loaded by oil from the outlet side of the pump into the space between the inner bushings and the pump body. These spaces are sealed by O-rings and as the bushing area under pressure in the space is slightly greater than the area under pressure between the gears, the pressure in the space will push the bushings against the gears. The complete gear and bushing assembly will therefore be pressed against the body side cover at all output pressures and leakage between the gear side faces is reduced to a minimum.

The cover plate is bolted on top of the pump body and is fitted with a pressure relief valve which limits the pump output pressure and prevents the pump from being overloaded.

Removal and Installation

1. Remove the backhoe as instructed in Section 9100, if equipped.
2. Remove dirt and grease from the power take-off unit and surrounding area.
3. The pump is located inside the power take-off housing and to gain access to the pump the power take-off unit must be removed.
4. Remove the power take-off unit as instructed in Section 6431.

3. Push the cylinder out of the axle case.
4. Install a large O-ring on the front of the ram cylinder.
5. Install a gasket on the axle case.
6. Push the ram cylinder into the axle housing.
7. Align the ram cylinder holes with the holes in the axle housing. Install the ram shaft and right-hand bracket.
9. If a pin is to be replaced, two new holes must be drilled as shown in Figure 32.
10. Press the new pins into the ram cylinder cover until they are .728-.718 inch (18.49-18.24 mm) from the cover.

Locking Latch

1. Put a drain pan below the ram cylinder cover.
2. Remove the cap screws and bolts from the ram cylinder cover.
3. Remove the ram cylinder cover and place on a clean bench.
4. Turn the lever to the engaged position and remove the snap ring from the end of the latch pin.
5. Remove the lever and the dirt seal.
6. Remove the latch pin locating screw from the ram cylinder cover boss and remove the inner snap ring.
7. Push the latch pin in out of the ram cylinder cover and remove the O-ring, spacer and spring from the latch pin.
8. Do not attempt to remove the two pins in the ram cylinder cover unless they are to be replaced.
11. Install the spring, spacer and O-ring on the latch pin.
12. Lubricate the latch pin with clean transmission oil and install in the ram cylinder cover.
13. Align the latch pin groove with the locating screw hole in the cover.
14. Clean the locating screw and apply Loctite 242 blue to the screw. Install the screw until it touches the bottom of the groove in the latch pin, then turn it back out one quarter of a turn.
15. Push latch pin into position to compress the spring and expose the inner snap ring groove.
16. Install snap ring. Lubricate the latch pin and grease and install the dirt seal.
17. Install the latch lever in the engaged position and secure in place with the snap ring.
18. Operate the latch lever several times to assure proper operation.
19. Apply a thin coat of form-in-place gasket material, Case part no. M20704, or equivalent to ram cylinder cover.
20. Install the ram cylinder cover on the cylinder housing.

TABLE OF CONTENTS

Specifications	8090- 3
Spanner Wrench Set	8090- 3
All Loader Cylinders, Backhoe Dipper, Bucket, Stabilizer and Swing Cylinders	8090- 4
Removal	8090- 4
Installation	8090- 4
Loader Cylinders	8090- 5
Disassembly	8090- 5
Inspection	8090- 5
Assembly	8090- 7
Stabilizer Cylinder	8090- 8
Disassembly	8090- 8
Inspection	8090- 8
Assembly	8090- 8
Swing and Bucket Cylinder	8090-10
Disassembly	8090-10
Inspection	8090-10
Assembly	8090-10
Boom and Dipper Cylinders	8090-12
Disassembly	8090-12
Inspection	8090-12
Assembly	8090-14

4. Install O-rings and backup ring in piston grooves as shown in Figure 9.
5. Place a support under rod at piston end, Figure 8. Install piston assembly on rod and secure in place with self locking nut. Tighten nut to specifications on page 8090-3.
6. Secure the cylinder tube in a vise and thoroughly lubricate the cylinder wall and piston with clean hydraulic oil. Install the piston rod straight into the tube. After the piston has started into the smooth portion of the tube, push gland into tube and install gland retaining ring. Install gland retaining nut finger tight.
7. If assembling a swing cylinder, align the fitting hole in the gland with the hole in the cylinder tube and install fitting. Tighten gland retaining nut.
8. The piston rod can now be worked farther into the tube with a rod through the rod eye or a soft hammer.
9. If assembling a swing cylinder, install ball check relief valve. Be sure ball and spring are in the proper position and tighten plug.

BOOM AND DIPPER CYLINDERS

Disassembly

1. Secure cylinder in vise using care not to distort the tube. Remove the gland retaining cap.
2. Carefully pull the piston rod from the cylinder. Pull the rod straight out to prevent damage to the cylinder wall.
3. Secure piston rod eye in a vise and remove piston nut, Figure 10. Nut torque is 400-500 foot-pounds (542-678 N m).

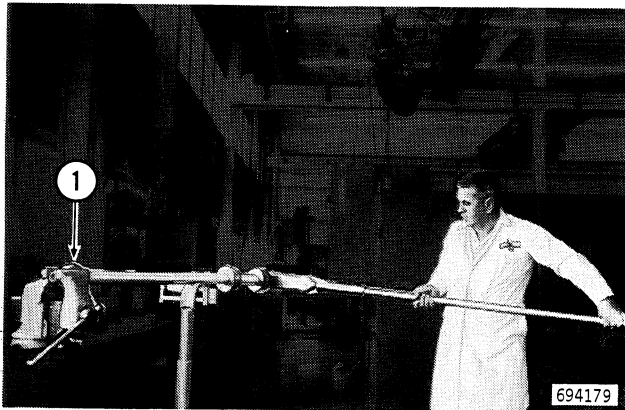

1. Clamp Across Rod Eye

Figure 10 - Removing Piston Bolt

4. Remove piston assembly and piston spacer from piston rod. Remove piston O-rings and backup rings.

5. Remove gland from rod. If necessary, the gland may be driven off the rod with a soft hammer. Refer to Figure 11 and disassemble gland.

Inspection

1. Wash parts in cleaning solvent and dry with moisture free compressed air.
2. Discard piston and gland O-rings, backup rings, rod wiper and other parts found to be excessively worn.
3. Shine a light into the cylinder tube. If it has deep grooves or score marks, or has been severely damaged in any way, it must be replaced.
4. Inspect piston rod for alignment. Replace if bent; do not attempt to straighten.
5. Before assembling the cylinder, remove any minor nicks, scratches, etc. on the rod or in the cylinder tube with a medium grit emery cloth. Polish with a rotary motion rather than lengthwise.
6. Scoring, pitting, etc. are signs of possible oil contamination. Check hydraulic oil for contamination.
7. Remove closed end fitting being careful not to lose spring. Remove closed end tube and remove and discard O-rings and backup rings.

27. Remove the cap screw from the suction tube clamp, Figure 22. Remove the suction tube.

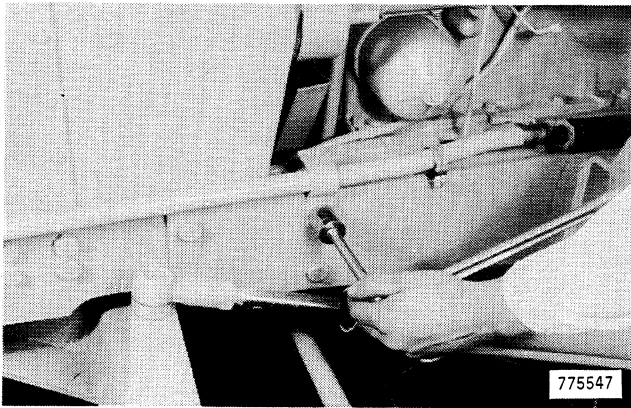

Figure 22

28. Connect a chain hoist to the loader upright, Figure 23.

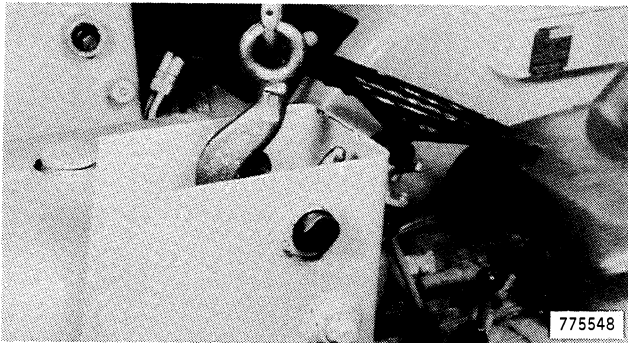

Figure 23

29. Remove the bolts and cap screws from the step. Pry the step back to disengage the dowel pin at the front of the step. Lower the step down out of the way. Remove the cap screws from the loader upright, Figure 24.

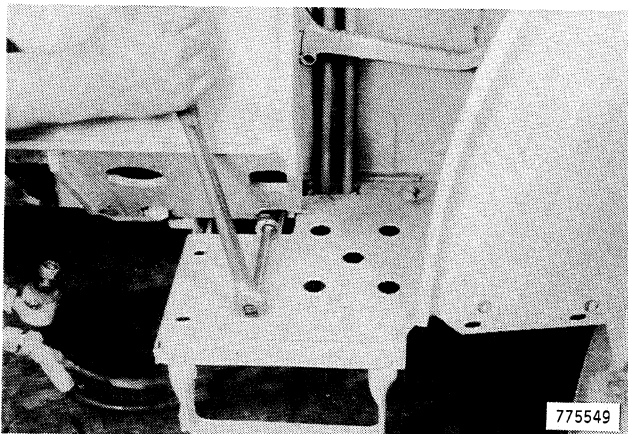

Figure 24

30. Remove the loader upright, Figure 25.

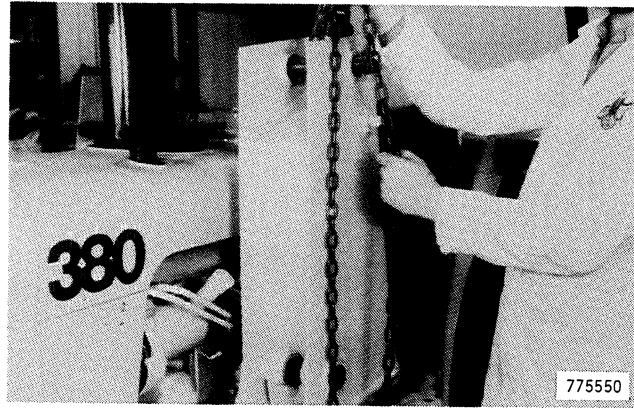

Figure 25

31. Disconnect the hoses on the right-hand lift cylinder. Put a plug and cap in the hoses and tubes.
32. Remove the snap ring from the pivot pin on the inside of the right-hand lift cylinder.
33. Pull the pivot pin from the right-hand lift cylinder while supporting the lift cylinder. Remove the right-hand lift cylinder.
34. Disconnect the loader lift cylinder cross tubes at the tees, Figure 26.

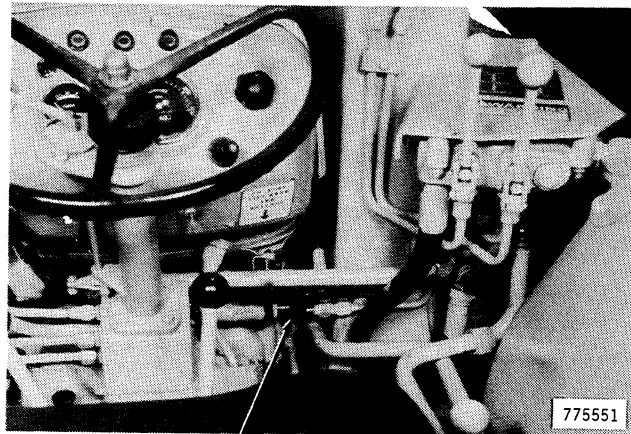
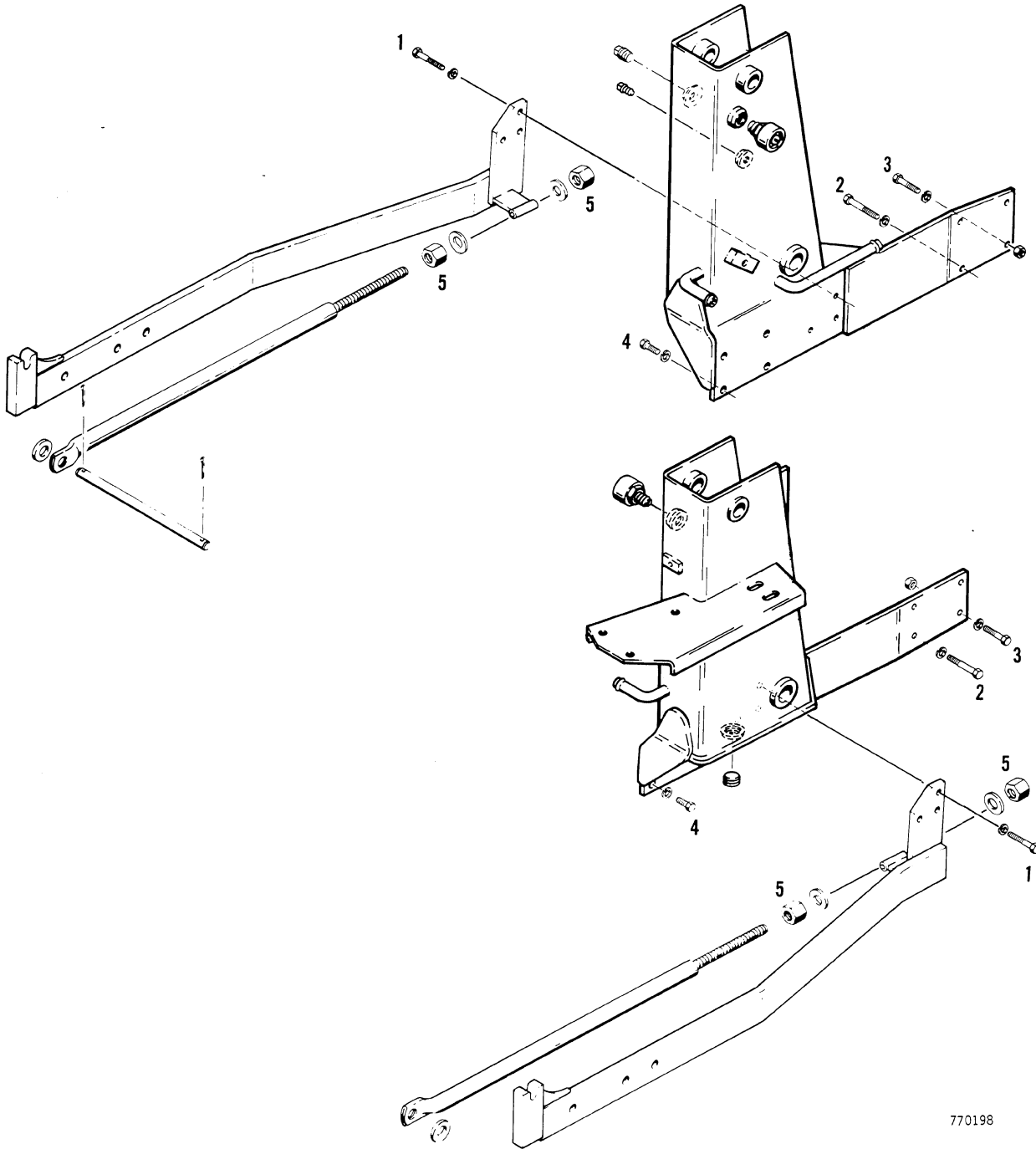

Figure 26



770198

5/8 INCH BOLT LENGTHS:

- 1. 2-1/4 INCHES (57 mm)
- 2. 2-3/4 INCHES (70 mm)

- 3. 1-3/4 INCHES (44 mm)
- 4. 1-1/2 INCHES (38 mm)

5. REFER TO TORQUING PROCEDURE
IN THIS SECTION

Figure 54 - Loader Upright Installation
Dual Reservoir Loader and Backhoe

CLICK HERE TO **DOWNLOAD** THE COMPLETE MANUAL

- Thank you very much for reading the preview of the manual.
- You can download the complete manual from: www.heydownloads.com by clicking the link below



- Please note: If there is no response to CLICKING the link, please download this PDF first and then click on it.

CLICK HERE TO **DOWNLOAD** THE COMPLETE MANUAL