

1835C Uni-Loader  
Service Manual

Table of Contents

Description	Section No.	Form No.
<b>General</b>		
	<b>Tab 1</b>	
Loctite Product Chart		8-98900
Safety Rules, Service Manual Introduction and Torque Specifications	1001	8-68450
Diesel Engine Specifications	1010	8-58770
Gasoline Engine Specifications	1010	8-58780
General Machine Specifications	1210	8-68460
Maintenance and Lubrication	1212	8-68470
<b>Engine</b>		
	<b>Tab 2</b>	
Engine Removal and Installation and Radiator Removal and Installation	2000	8-68500
Air Cleaner and Mufflers	2001	8-68510
Cylinder Head, Valve Train and Camshaft - Gasoline	2015	8-57880
Cylinder Head, Valve Train and Camshaft - Diesel	2015	8-57960
Cylinder Block, Pistons and Connecting Rods - Gasoline	2025	8-57890
Cylinder Block, Pistons and Connecting Rods - Diesel	2025	8-57970
Crankshaft - Gasoline	2035	8-57900
Crankshaft - Diesel	2035	8-57980
Oil Pump - Gasoline	2045	8-57910
Oil Pump - Diesel	2045	8-57990
Cooling System - Gasoline	2055	8-57920
Cooling System - Diesel	2055	8-58000
Engine Lubrication - Gasoline	2555	8-57930
Engine Lubrication - Diesel	2555	8-58010
Ignition System - Gasoline	2065	8-58710
<b>Fuel System</b>		
	<b>Tab 3</b>	
Engine Controls, Fuel Lines and Fuel Tank	3001	8-68520
Carburetor, Fuel Pump and Governor - Gasoline	3002	8-58700
Fuel Injection Pump and Fuel Filter - Diesel	3312	8-58810
Fuel Injectors and Glow Plugs - Diesel	3313	8-58800
<b>Electrical</b>		
	<b>Tab 4</b>	
Removal and Installation of Electrical Components	4000	8-68530
Electrical Specifications and Troubleshooting	4002	8-68540
Electrical Schematics	4003	8-68550
Battery	4005	8-44360
Starter Motor - Gasoline	4006	8-57940
Starter and Solenoid - Diesel	4006	8-58020
Alternator - Gasoline	4007	8-57950
Alternator - Diesel	4007	8-58030

CLICK HERE TO **DOWNLOAD** THE COMPLETE MANUAL

- Thank you very much for reading the preview of the manual.
- You can download the complete manual from: [www.heydownloads.com](http://www.heydownloads.com) by clicking the link below



- Please note: If there is no response to CLICKING the link, please download this PDF first and then click on it.

CLICK HERE TO **DOWNLOAD** THE COMPLETE MANUAL

## TORQUE SPECIFICATIONS - METRIC HARDWARE

Use the following torques when special torques are not given.

These values apply to fasteners with coarse threads as received from supplier, plated or unplated, or when lubricated with engine oil. These values do not apply if graphite or molydisulfide grease or oil is used.

<b>Grade 8.8 Bolts, Nuts, and Studs</b>		
		
Size	Pound-Feet	Newton metres
<b>M4</b>	2-3	3-4
<b>M5</b>	5-6	6.5-8
<b>M6</b>	8-9	10.5-12
<b>M8</b>	19-23	26-31
<b>M10</b>	38-45	52-61
<b>M12</b>	66-79	90-107
<b>M14</b>	106-127	144-172
<b>M16</b>	160-200	217-271
<b>M20</b>	320-380	434-515
<b>M24</b>	500-600	675-815
<b>M30</b>	920-1100	1250-1500
<b>M36</b>	1600-1950	2175-2600

<b>Grade 10.9 Bolts, Nuts, and Studs</b>		
		
Size	Pound-Feet	Newton metres
<b>M4</b>	3-4	4-5
<b>M5</b>	7-8	9.5-11
<b>M6</b>	11-13	15-17.5
<b>M8</b>	27-32	37-43
<b>M10</b>	54-64	73-87
<b>M12</b>	93-112	125-150
<b>M14</b>	149-179	200-245
<b>M16</b>	230-280	310-380
<b>M20</b>	450-540	610-730
<b>M24</b>	780-940	1050-1275
<b>M30</b>	1470-1770	2000-2400
<b>M36</b>	2580-3090	3500-4200

### Grade 12.9 Bolts, Nuts, and Studs



Usually the torque values specified for grade 10.9 fasteners can be used satisfactorily on grade 12.9 fasteners.

## STANDARD TORQUES

### STANDARD TORQUE DATA FOR NUTS AND BOLTS

Where no special torque data is specified, the following torque figures can be applied. Threads must be lubricated with engine oil or chassis grease. Apply the minimum figure to bolts that have previously been used.

Thread Size	PHOSPHATE COATED FASTENERS							
	Class 8.8 Min		Class 8.8 Max		Class 9.8 Min		Class 9.8 Max	
	Nm	lb ft	Nm	lb ft	Nm	lb ft	Nm	lb ft
M6	8	6	11	8	8	6	11	8
M8	20	15	24	18	20	15	24	18
M10	34	25	40	30	34	25	40	30
M12	75	55	81	60	75	55	81	60
M14	122	90	135	100	122	90	135	100
M16	190	140	203	150	190	140	203	150

#### PROPERTY CLASS MARKINGS

##### BOLTS AND SCREWS

The property class markings for metric bolts and screws are given in the table on the right. The marking is on the top of the bolt or screw head or may be indented on the side of the head.

PROPERTY CLASS	IDENTIFICATION SYMBOL	
	Bolts, Screws and Studs	Studs smaller than M12
8.8	8.8	○
9.8	9.8	+
10.9	10.9	□
12.9	12.9	△

**NOTE:** The CASE CORPORATION reserves the right to make improvements in design or changes in specifications at any time without incurring any obligation to install them on units previously sold.

# STANDARD TORQUES

## STANDARD TORQUE DATA FOR NUTS AND BOLTS

Where no special torque data is specified, the following torque figures can be applied. Threads must be lubricated with engine oil or chassis grease. Apply the minimum figure to bolts that have previously been used.

Thread Size	PHOSPHATE COATED FASTENERS							
	Class 8.8 Min		Class 8.8 Max		Class 9.8 Min		Class 9.8 Max	
	Nm	lb ft	Nm	lb ft	Nm	lb ft	Nm	lb ft
M6	8	6	11	8	8	6	11	8
M8	20	15	24	18	20	15	24	18
M10	34	25	40	30	34	25	40	30
M12	75	55	81	60	75	55	81	60
M14	122	90	135	100	122	90	135	100
M16	190	140	203	150	190	140	203	150

### PROPERTY CLASS MARKINGS

#### BOLTS AND SCREWS

The property class markings for metric bolts and screws are given in the table on the right. The marking is on the top of the bolt or screw head or may be indented on the side of the head.

PROPERTY CLASS	IDENTIFICATION SYMBOL	
	Bolts, Screws and Studs	Studs smaller than M12
8.8	8.8	○
9.8	9.8	+
10.9	10.9	□
12.9	12.9	△

**NOTE:** The CASE CORPORATION reserves the right to make improvements in design or changes in specifications at any time without incurring any obligation to install them on units previously sold.

# 1212

## MAINTENANCE AND LUBRICATION

### TABLE OF CONTENTS

<b>Fluids and Lubricants</b> .....	1212-2	<b>Engine Run-In Period</b> .....	1212-5
<b>Engine Oil Recommendations</b> .....	1212-3	<b>Maintenance Schedule (Gasoline Engine)</b> .....	1212-6
<b>Diesel Fuel</b> .....	1212-4	<b>Maintenance Schedule (Diesel Engine)</b> .....	1212-10
<b>Gasoline</b> .....	1212-4		

# MAINTENANCE SCHEDULE (DIESEL ENGINE)

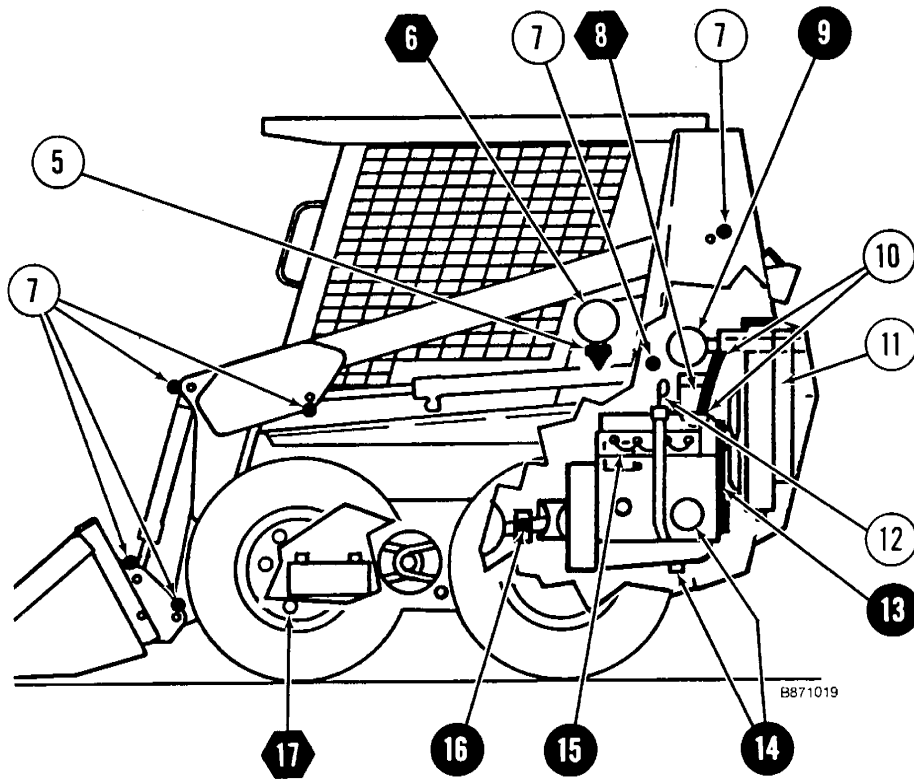
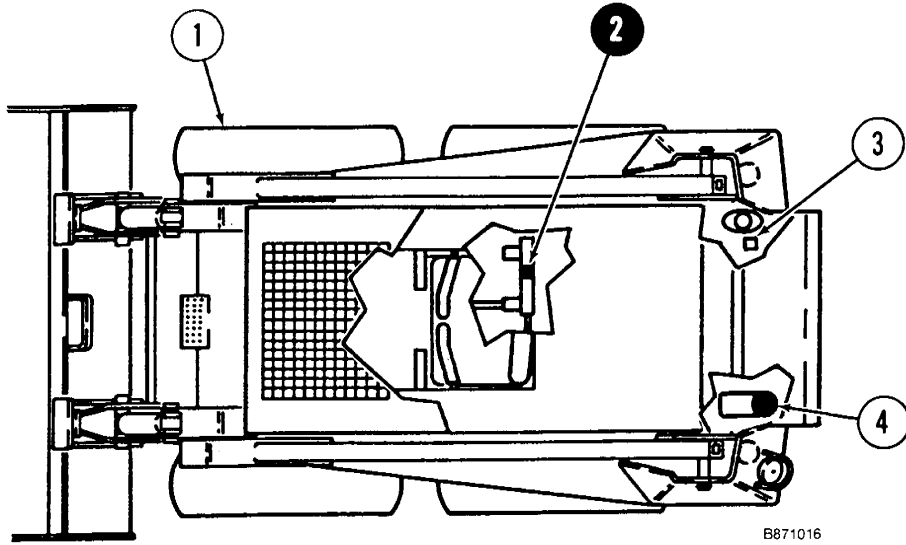

**STEP 35**

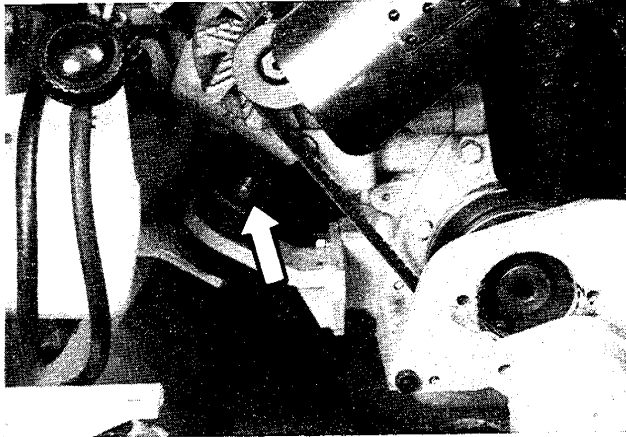

876545

Loosen and remove the bolts and self-locking nuts that fasten the rear engine mounts to the frame.

**STEP 36**



876524

Loosen and remove the bolts and self-locking nuts that fasten the front engine mounts to the frame.

**STEP 37**

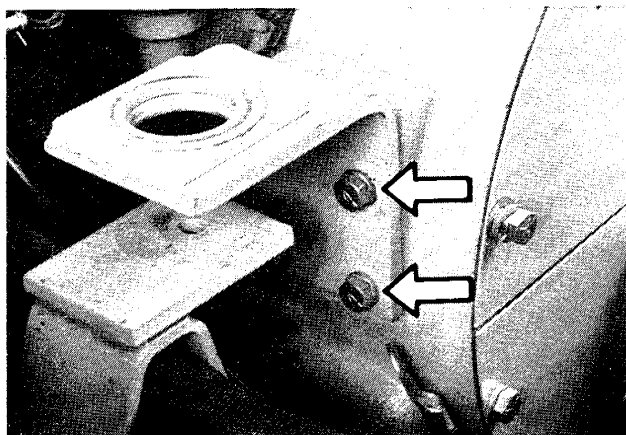

876540

Loosen and remove the cap screws and lock washers that fasten the right front engine mounts to the frame.

**STEP 38**

Move the engine toward the rear of the machine until the drive coupling on the flywheel disengages from the drive shaft of the tandem pump.

**STEP 39**

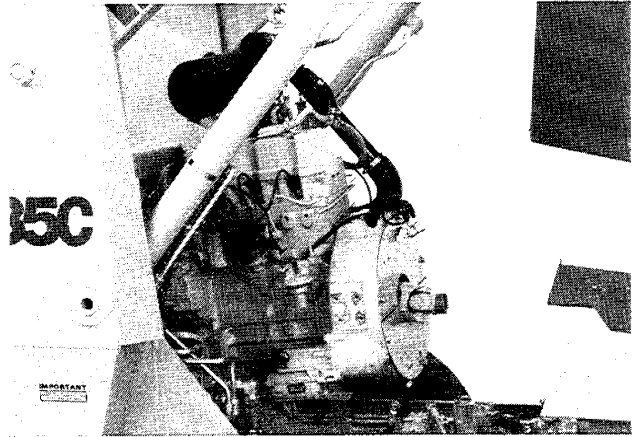

876553

Lift the engine from the machine.

**Installation**

**STEP 40**

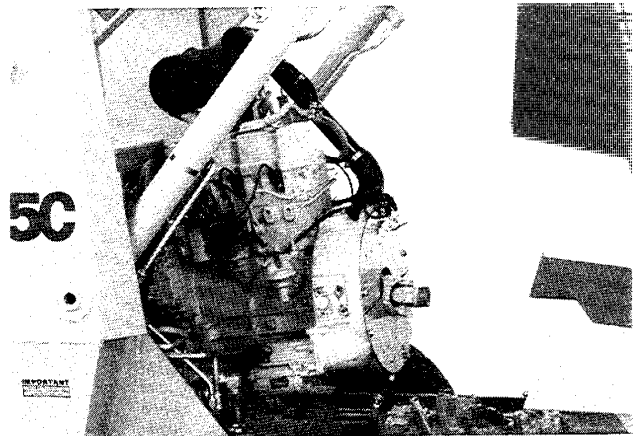

876553

Put the engine in position over the frame.

**STEP 41**

Lower the engine and move the engine toward the front of the machine until the drive coupling on the flywheel engages the drive shaft on the tandem pump.

**STEP 89**

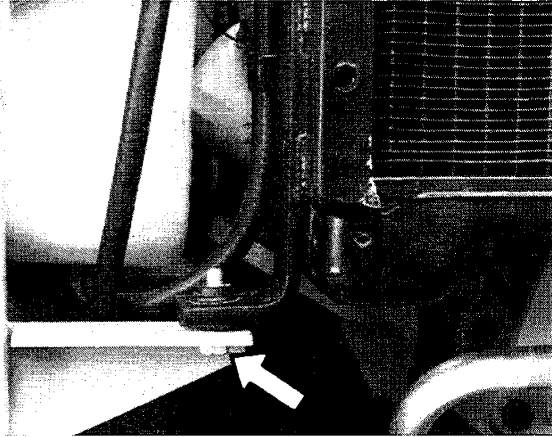

876543

Loosen and remove the cap screws and washers that fasten to the radiator mounting brackets.

**STEP 92**

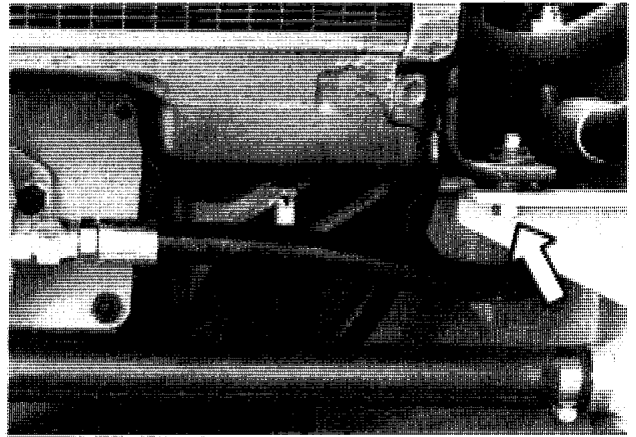

876532

Install the cap screws and washers that fasten the radiator to the radiator mounting brackets.

**STEP 90**

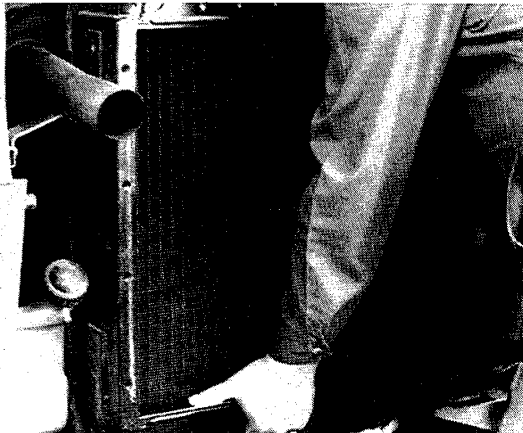

515930R

Pull the radiator to the rear to disconnect the bottom radiator hose from the engine. Remove the radiator from the machine.

**STEP 93**

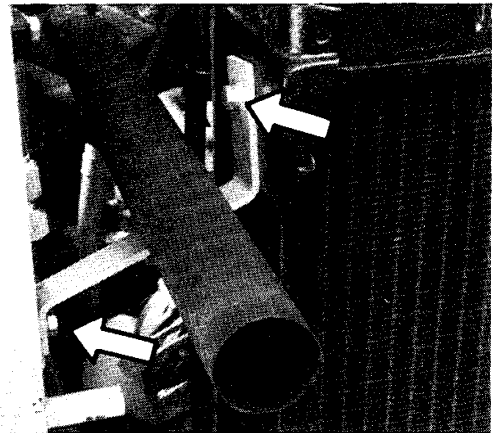

876546

Install the cap screws, lock washers, and flat washers that fasten the radiator to the mounting straps.

**Installation**

**STEP 91**

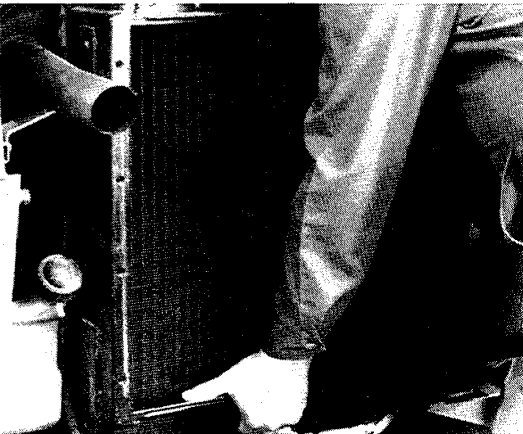

515930R

Put the radiator in position on the radiator mounting brackets. Connect the bottom radiator hose to the engine.

**STEP 94**

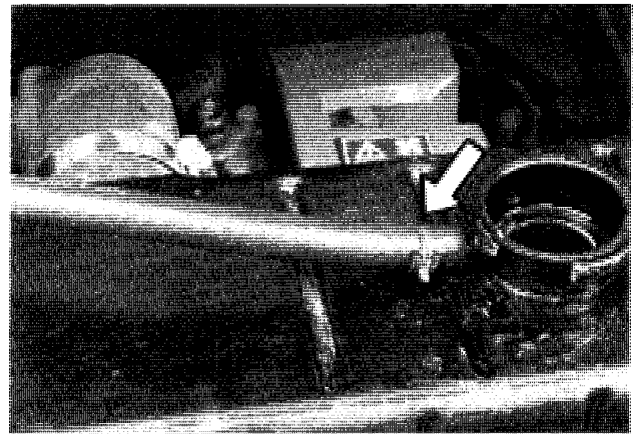

876548

Install the hose for the coolant reservoir in the clamps on the radiator. Connect the hose to the radiator.

# **Section 2015**

**CYLINDER HEAD, VALVE TRAIN, CAMSHAFT  
TM20 Gasoline Engine**

**STEP 20**

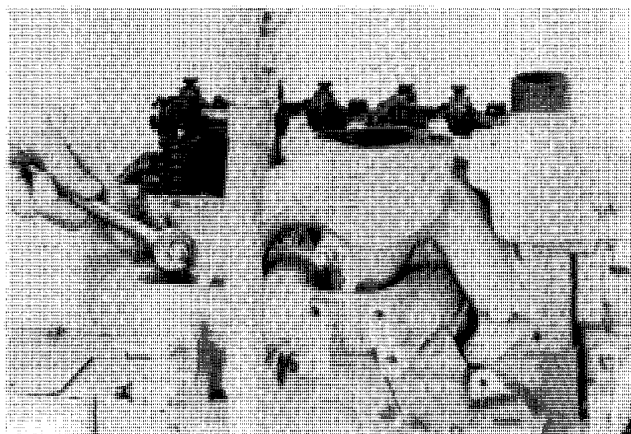

Remove the intake and exhaust manifold nuts.

**STEP 21**

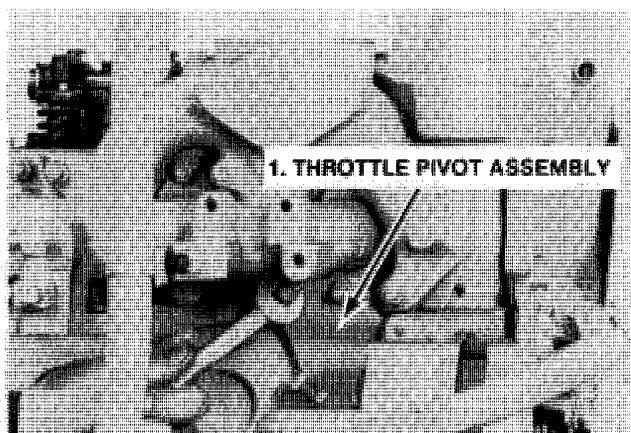

Remove the throttle pivot assembly bracket.

**NOTE:** *The dipstick tube is removed for photographic purposes only.*

**STEP 22**

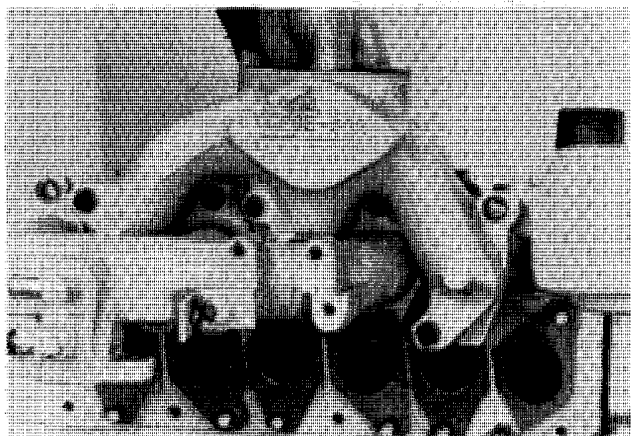

Remove the intake and exhaust manifold.

**STEP 23**

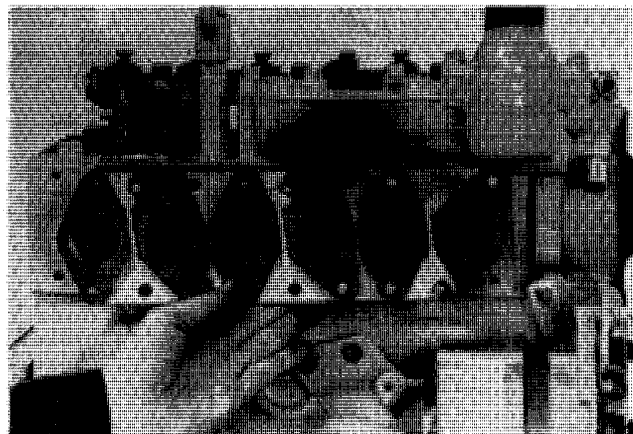

Remove the gasket.

**STEP 24**

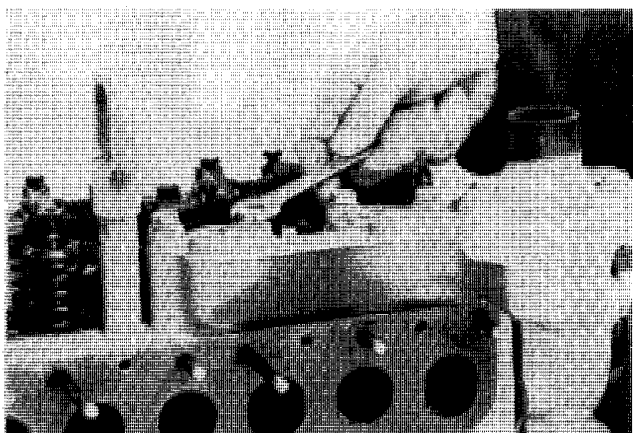

Remove the bolts from the coolant manifold.

**STEP 25**

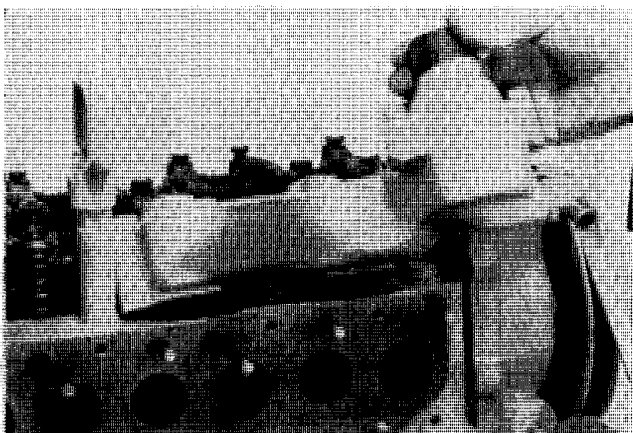

Remove the coolant manifold and gasket.

**STEP 59**

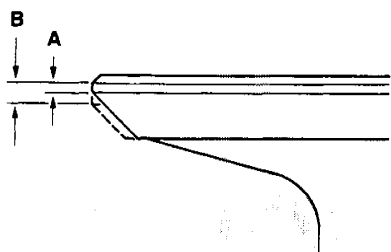

If the measurement (A) on the old valve is less than half the measurement (B) on a new valve, replace the valve.

**STEP 60**

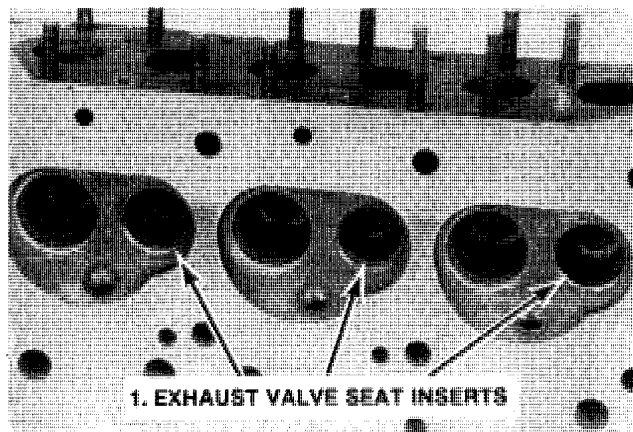

Inspect all exhaust valve seat inserts in the cylinder head. Replace any that are loose, cracked or otherwise damaged.

**Valve Seat Replacement**

**IMPORTANT:** *J.I. Case do not recommend installing new inserts that have the same outside diameter as the one removed. The following chart shows the dimensions of Standard Inserts and Counterbores.*

**DIMENSIONS OF STANDARD INSERTS AND COUNTERBORES**

Engine Model	Outside Dia. of Insert (A)	Inside Dia. of Counterbore (B)	Press Fit
TM	1.3981 inch to 1.3971 inch	1.3941 inch to 1.3931 inch	.003 inch to .005 inch
	(35.513 mm) to (35.482 mm)	(35.410 mm) to (35.385 mm)	(.077 mm) to (.128 mm)

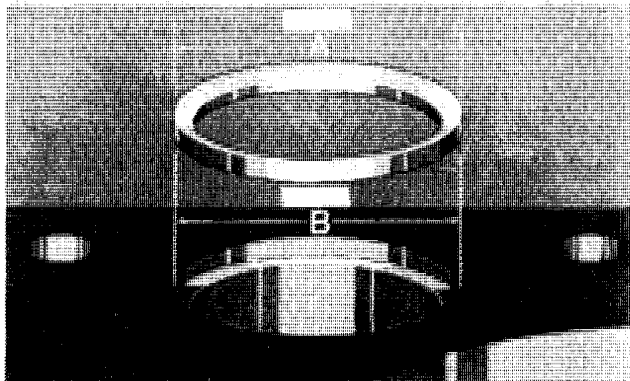

**NOTE:** *When OVERSIZE inserts are used, dimensions of the insert and counterbore increase in size 0.010 inch, 0.020 inch (0.25 mm, 0.50 mm) depending on the oversize.*

**STEP 61**

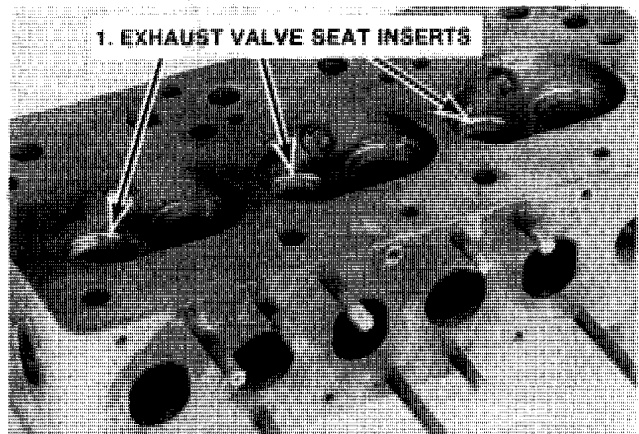

Use a suitable puller and remove the exhaust valve seat inserts.

**STEP 62**

When replacing new inserts, clean and counterbore for 0.010 inch (0.25 mm) larger inserts using counterbore tool with correct fitting pilot.

**NOTE:** *When machining the counterbore, be sure to go deep enough with the tool to clean up the bottom so that the insert will have full contact to carry away the heat.*

**STEP 110**

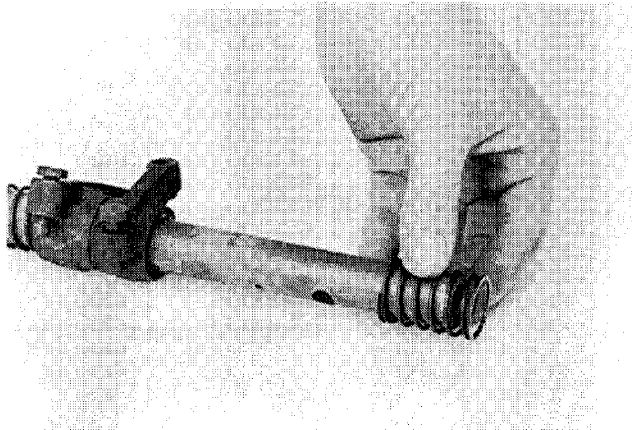

Install the spring.

**STEP 111**

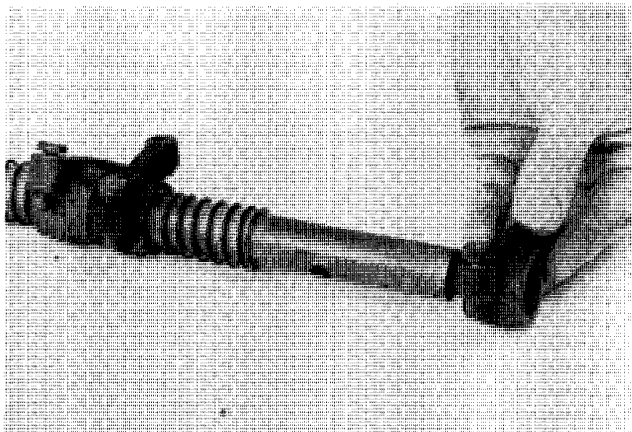

Install the exhaust rocker arm (No 3 cylinder).

**STEP 112**

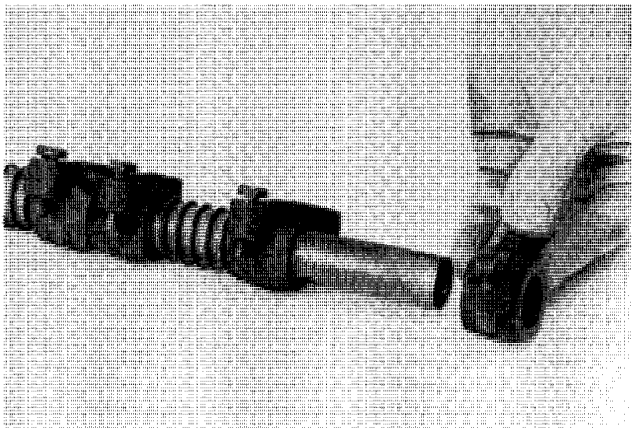

Install the intake rocker arm (No 3 cylinder).

**STEP 113**

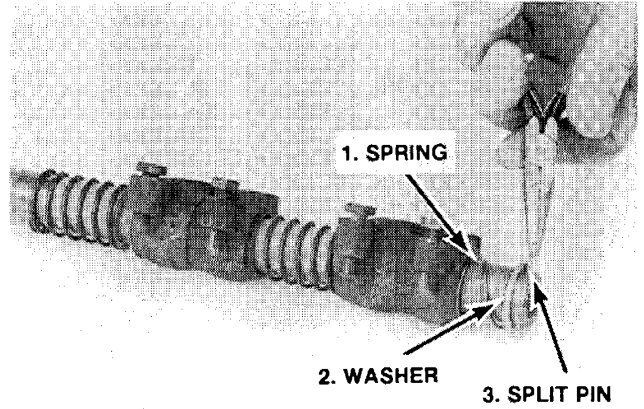

Install the spring, washer and new split pin.

**STEP 114**

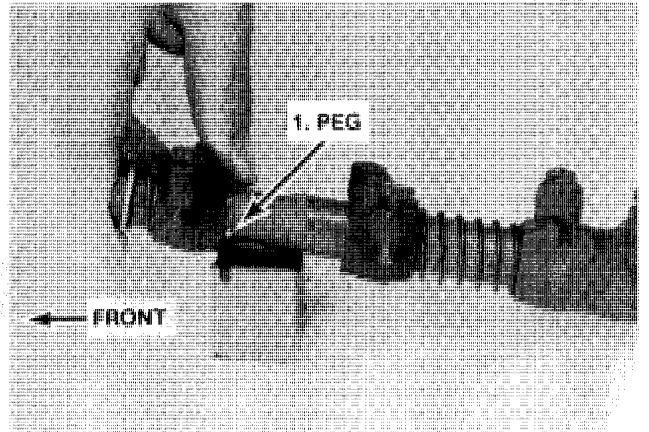

Install the front support block.

**NOTE:** *Align the peg in the shaft with the cut-out in the support block.*

**STEP 115**

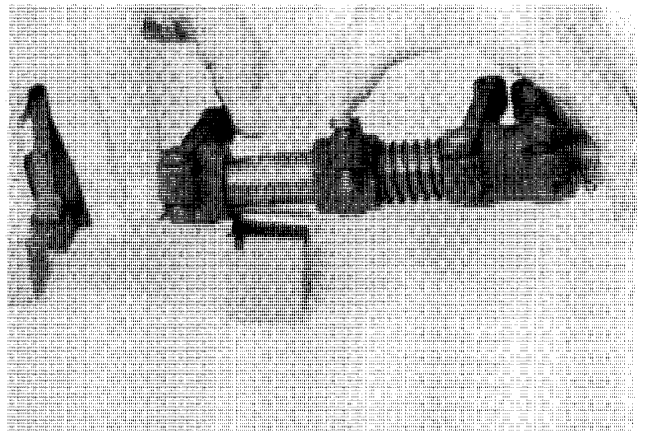

Separate the intake and exhaust rocker arms (No 2 cylinder) and install a support block.

## Camshaft Removal

### STEP 159

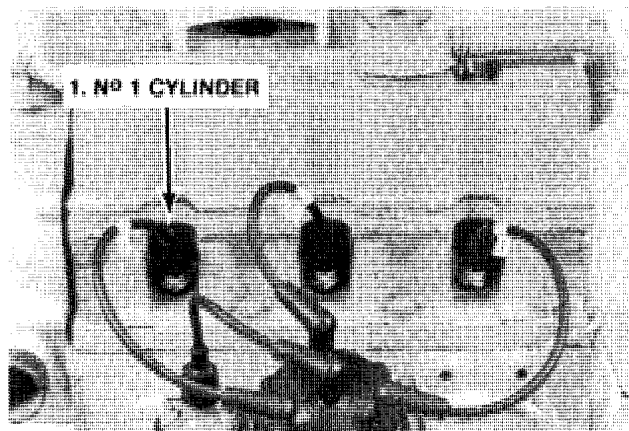

Starting at the front of the engine (N° 1 Cylinder) label the spark ignition leads as shown.

### STEP 160

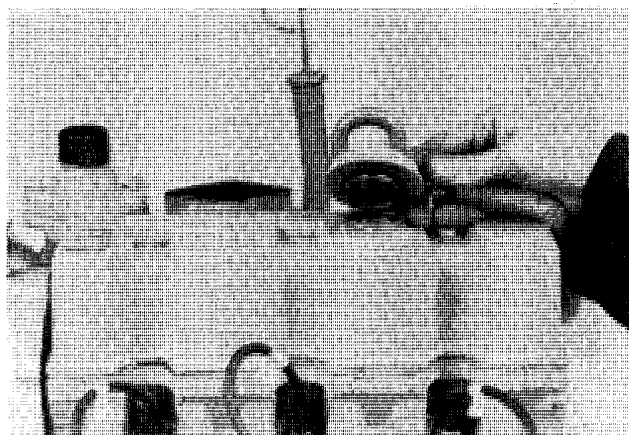

Remove the engine breather, filler cap, from the valve cover.

### STEP 161

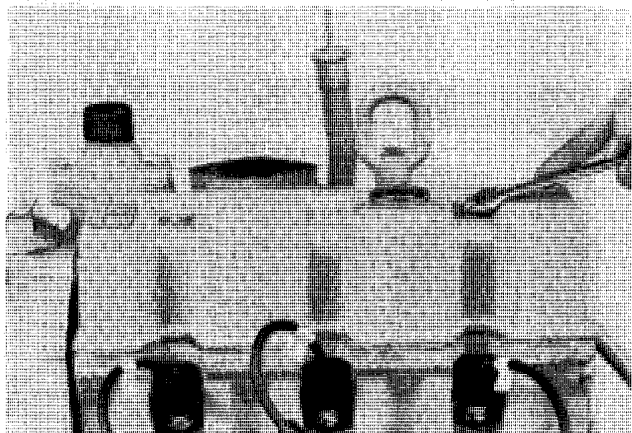

Remove the valve cover bolts.

### STEP 162

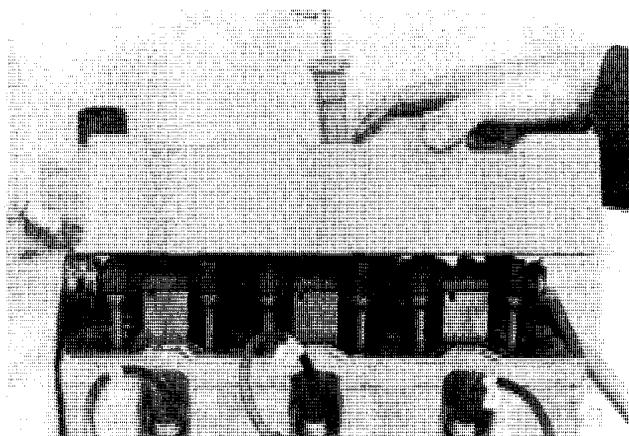

Remove the valve cover.

### STEP 163

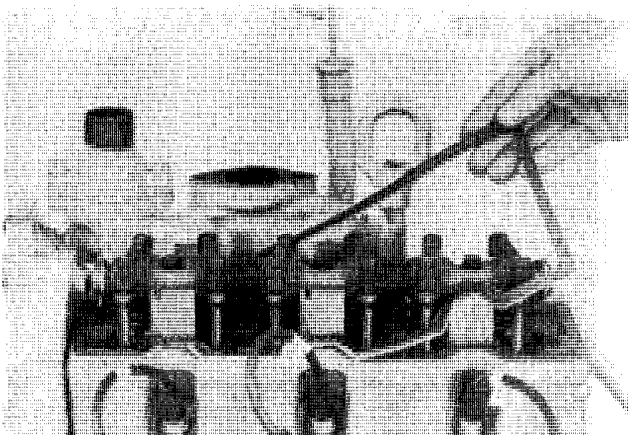

Remove the valve cover gasket.

### STEP 164

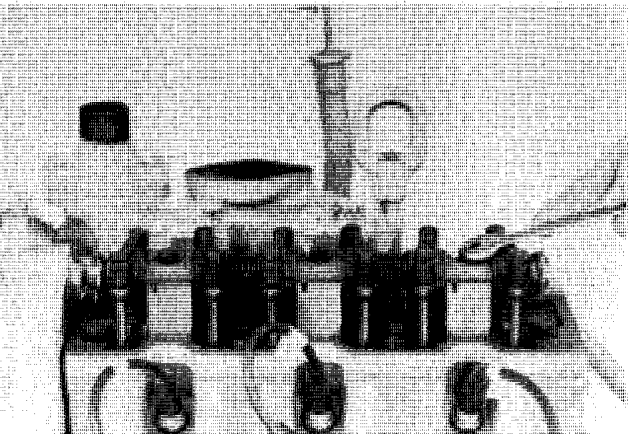

Remove the rocker arm shaft retaining bolts.

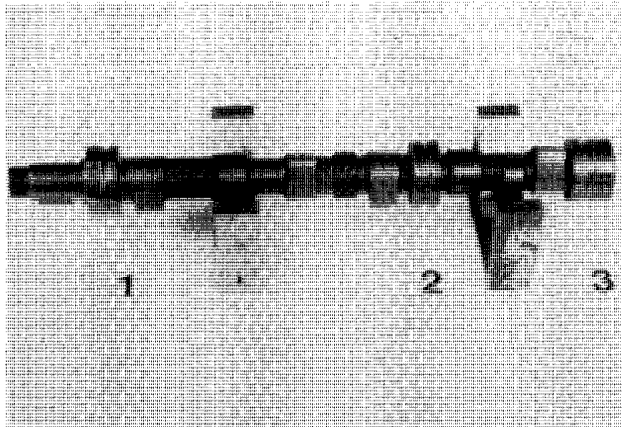
**STEP 212**

Inspect the condition of the cam lobes and the distributor drive gear. Replace the camshaft if damage or wear is found.

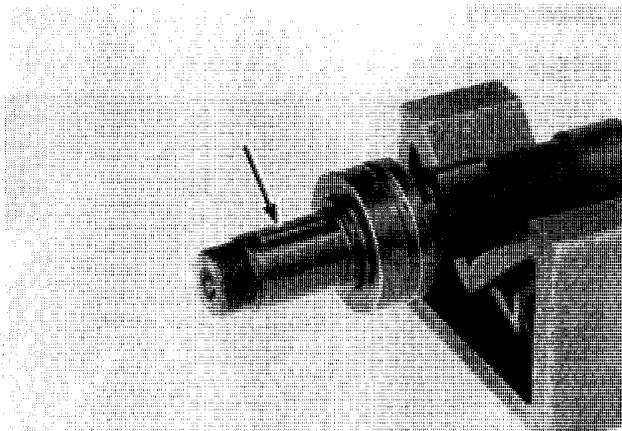
**STEP 213**

Check the condition of the key. Replace with a new key if necessary.

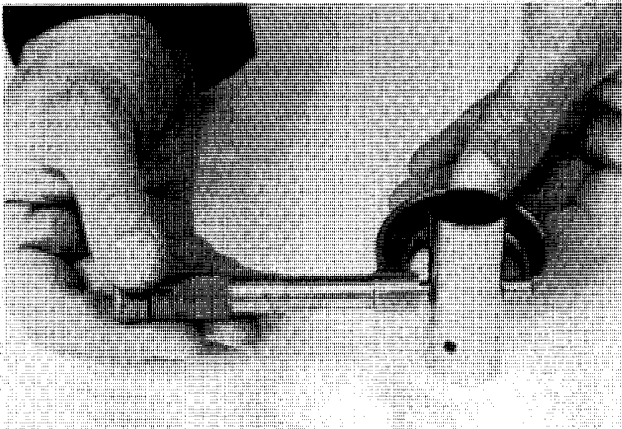
**STEP 214**

Check the outside diameter of the tappets. Replace with new tappets if the outside diameter is less than 0.9915 inch (25.181 mm).

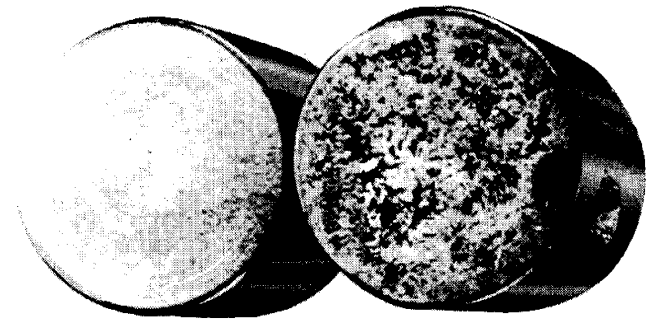
**STEP 215**

ACCEPTABLE

NOT ACCEPTABLE

Inspect the contact faces of the tappets. Two or three small pits are acceptable. If more pits are found replace with new tappets.

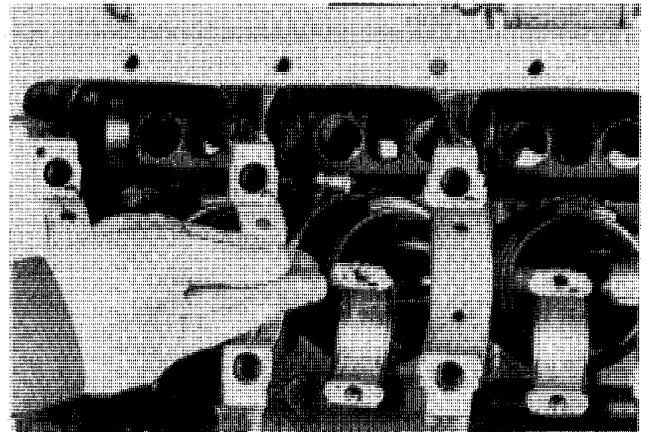
**STEP 216**

Measure the tappet bores in the cylinder crankcase. Refer to Specifications.

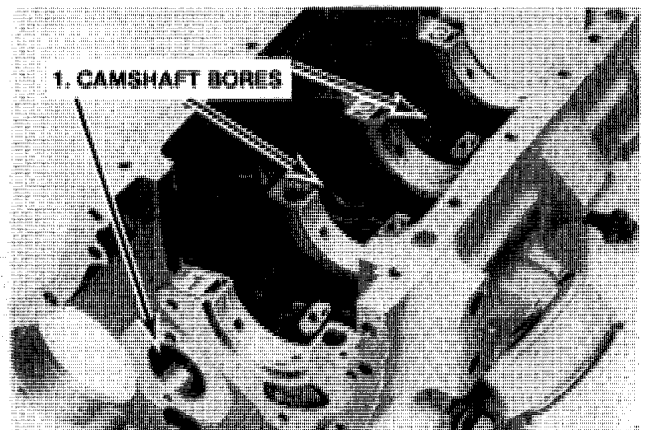
**STEP 217**

Measure the three camshaft bores in the crankcase. Refer to Specifications.

**NOTE:** *The crankshaft is removed for photographic purposes only*

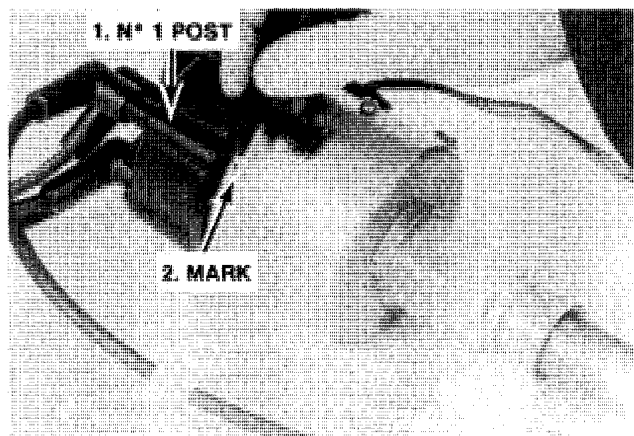
**STEP 264**

Install the distributor cap. Put a mark on the distributor body, opposite the N° 1 post on the distributor cap.

**STEP 265**

Remove the distributor cap.

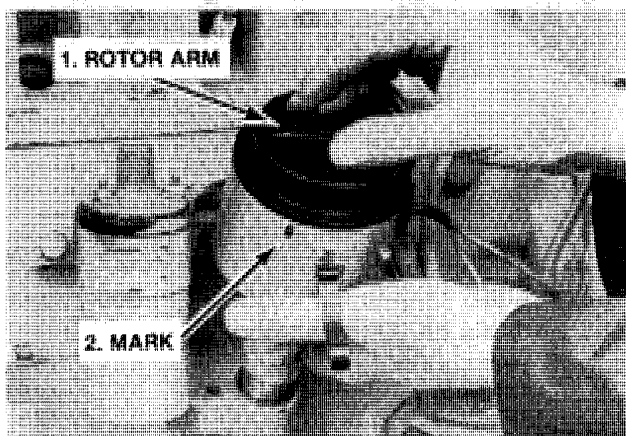
**STEP 266**

Hold the distributor in approximately the same position as removed and turn the rotor arm so that it is pointing before the mark on the distributor body.

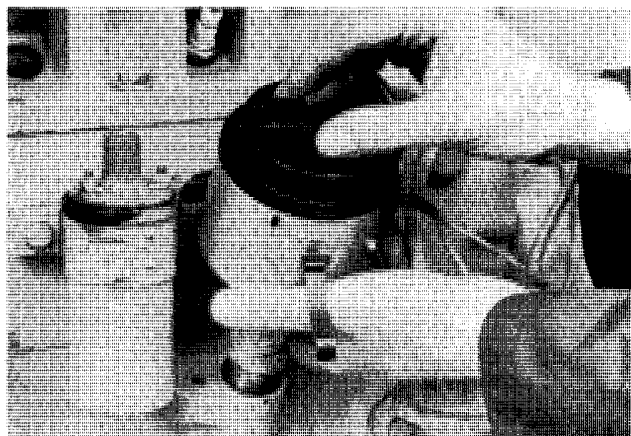
**STEP 267**

Push in the distributor to engage the drive gear.

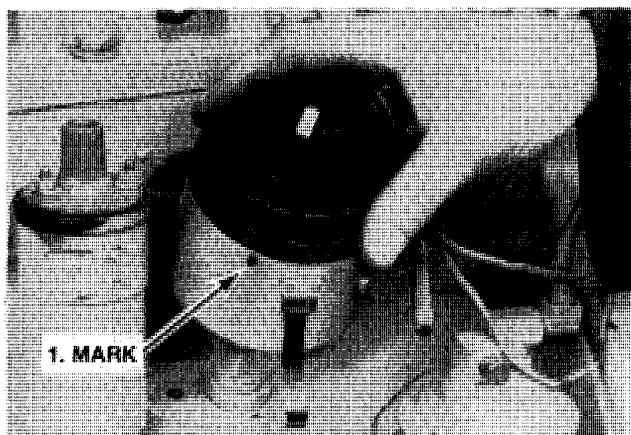
**STEP 268**

When the distributor drive gears engage, the drive gears will turn the rotor arm towards the mark on the distributor body.

**NOTE:** If the rotor arm is not in line with the mark, lift the distributor and turn the rotor arm. The distributor is in the correct position when the rotor arm points exactly toward the mark on the distributor body.

## GENERAL INFORMATION



**WARNING:** *This safety symbol is used in this manual to indicate important safety messages.*

*When you see this symbol, read the message carefully. It is shown when possible injury or death can be caused.*

**CLEANING** - Before you do any service work, steam clean the complete outside surface of the engine. Clean all metal parts except bearings, in mineral spirits or by steam cleaning. Do not use caustic soda for steam cleaning. After cleaning, dry all parts and put some oil on the parts. Clean oil passages with compressed air. Clean bearings in kerosene, dry the bearings completely and put some oil on the bearings to prevent rust.

**INSPECTION** - Check all parts when the parts are disassembled. Replace all parts that show much wear or damage. Small scoring can be removed with a hone or crocus cloth most of the time. Complete visual inspection for indications of wear, stress, pitting and the replacement of parts that have damage, as needed, will prevent early failure.

**BEARINGS** - Check bearings for free, smooth action. If bearings have a loose fit or rough action, replace the bearings. Wash the bearings with a good solvent or kerosene and permit to dry. **DO NOT DRY BEARINGS WITH COMPRESSED AIR.** Put oil on the bearings to prevent rust.

**GEARS** - Check all gears for wear and damage. Replace gears with damage or wear.

**OIL SEALS, O-RINGS AND GASKETS** - Always install new oil seals, o-rings and gaskets. Put petroleum jelly on seals and o-rings. Thoroughly clean all faces when installing new gaskets.

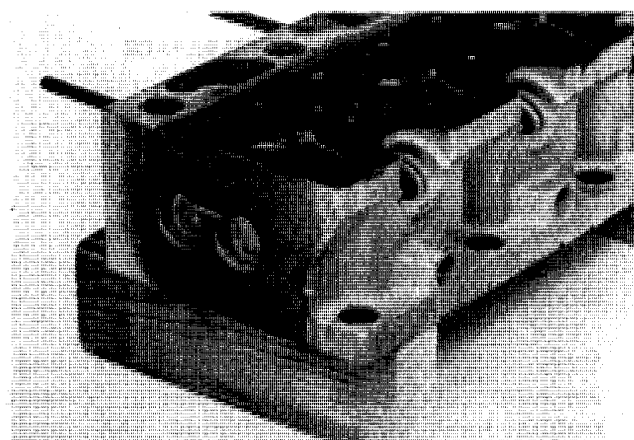
**STEP 50**

If the expansion plugs need replacing, the plugs must be drilled and pulled out.

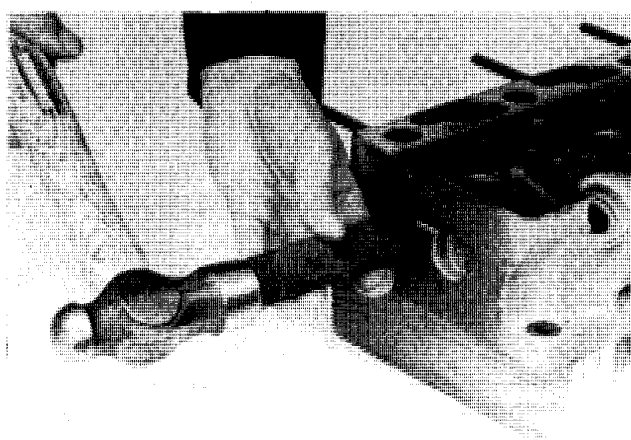
**STEP 51**

Apply heat resistant sealer to the new expansion plugs and install into the cylinder head.

## Valve Guide Replacement

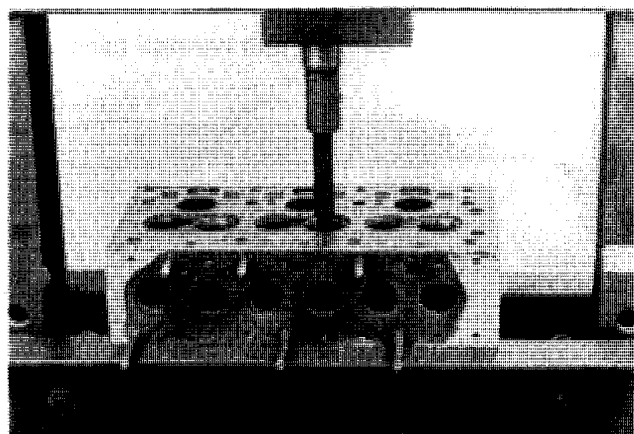
**STEP 52**

To replace the valve guides, put the cylinder head in a hydraulic press and press out the valve guides from the combustion chamber side.

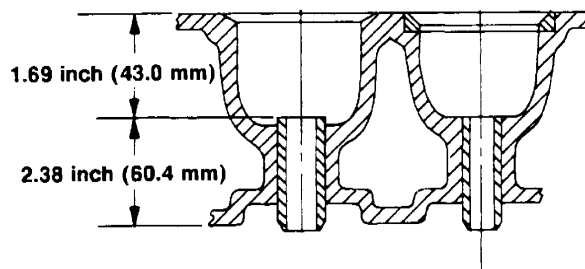
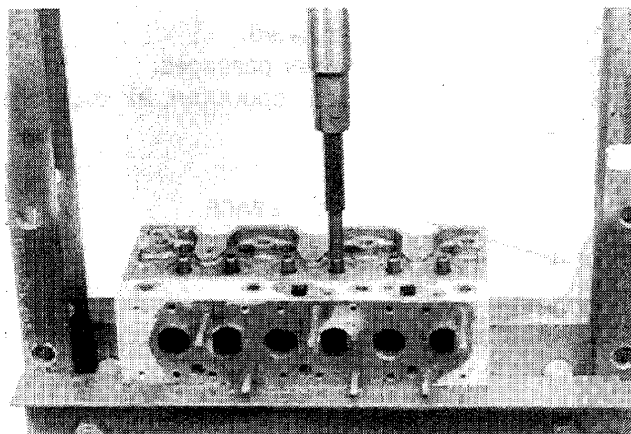
**STEP 53**

Press in new valve guides to the dimensions shown.

**IMPORTANT:** *It is not necessary to ream new valve guides. New valve guides are all reamed to the correct specifications, any attempt to ream new valve guides will remove the ferrox surface and damage the valve guide.*

**STEP 91**

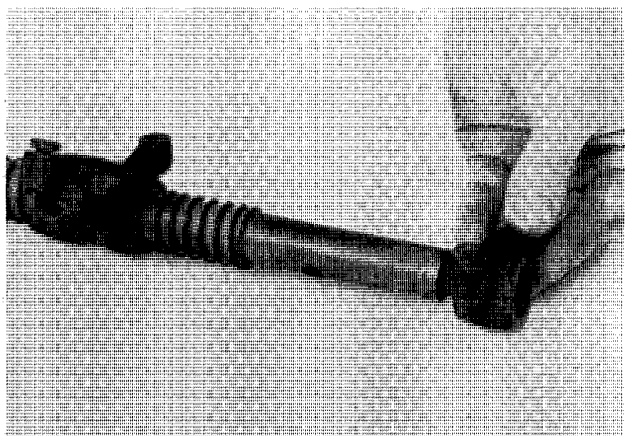

Remove the exhaust rocker arm (Nº 3 cylinder).

**STEP 94**

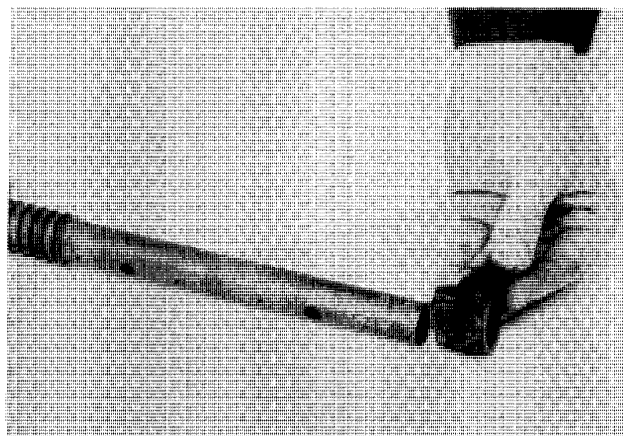

Remove the exhaust rocker arm (Nº 2 cylinder).

**STEP 92**

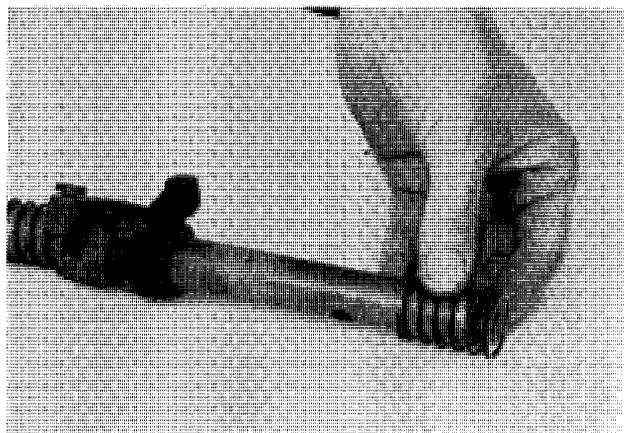

Remove the spring.

**STEP 95**

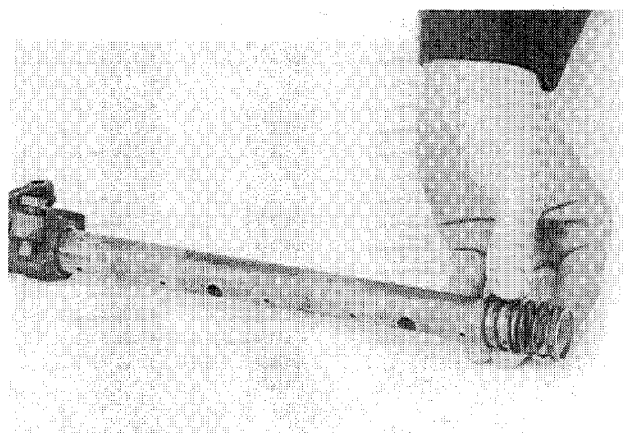

Remove the spring.

**STEP 93**

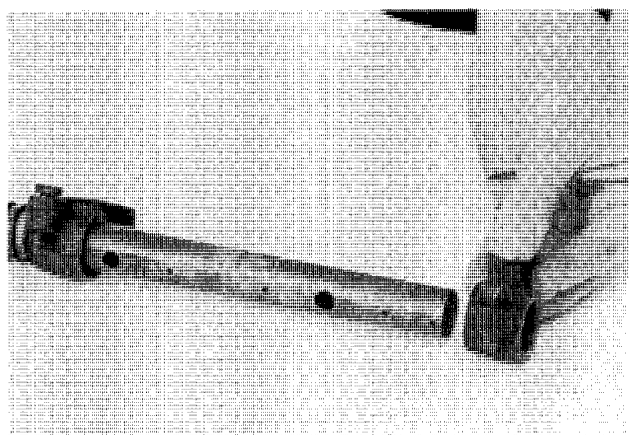

Remove the intake rocker arm (Nº 2 cylinder).

**STEP 96**

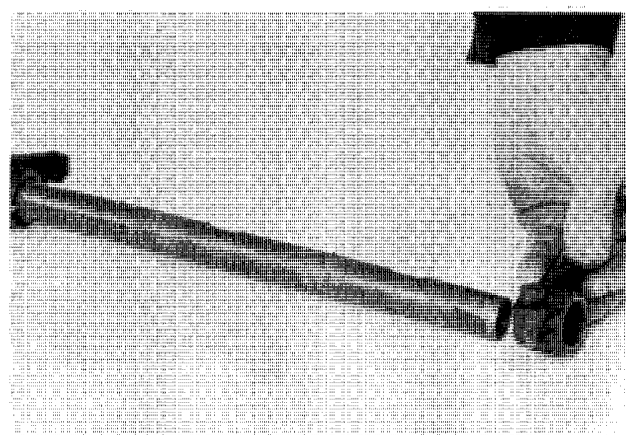

Remove the intake rocker arm (Nº 1 cylinder).

**STEP 144**

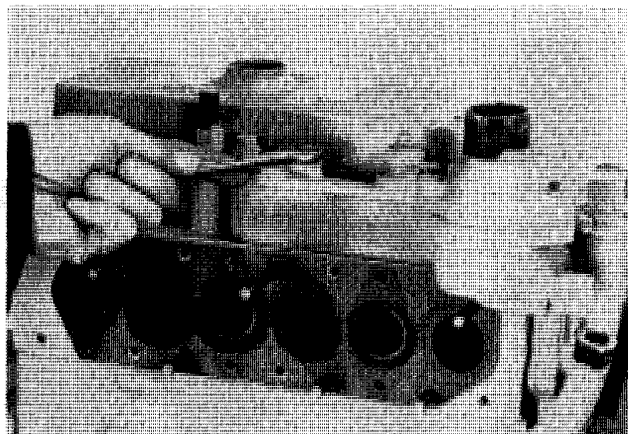

Install and tighten the water manifold bolts.

**STEP 145**

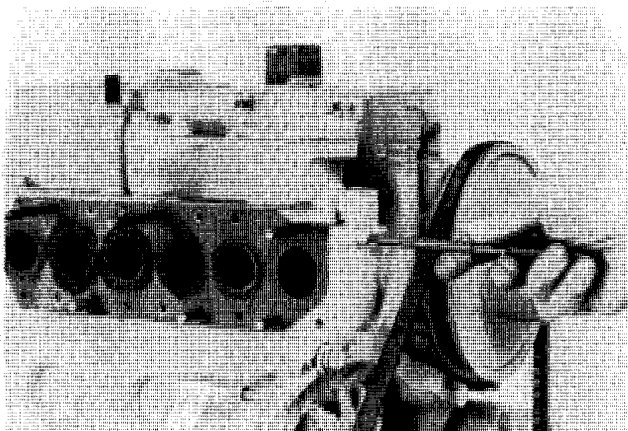

Connect the water manifold to engine oil cooler hose and tighten the clamp.

**STEP 146**

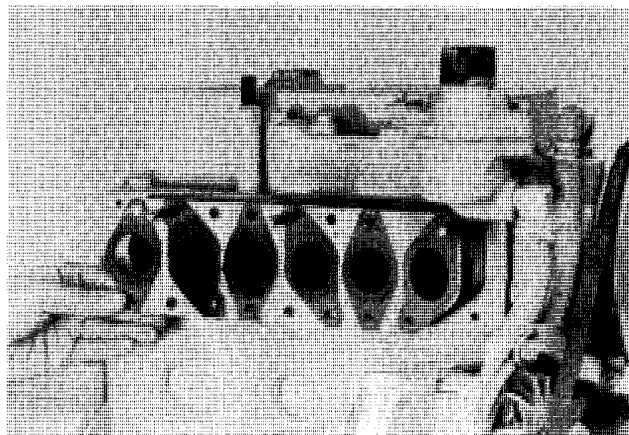

Install a new exhaust / inlet manifold gasket.

**STEP 147**

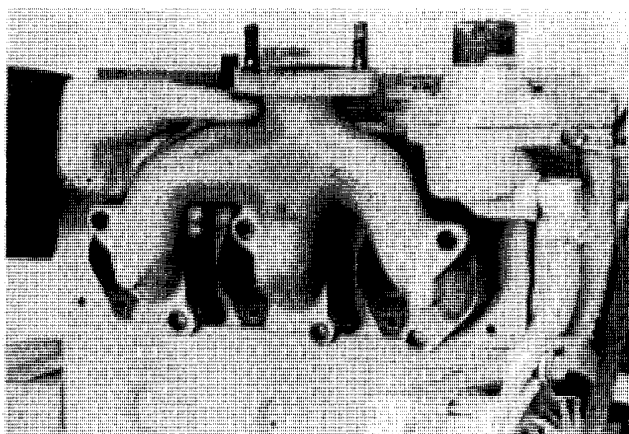

Install the exhaust manifold.

**STEP 148**

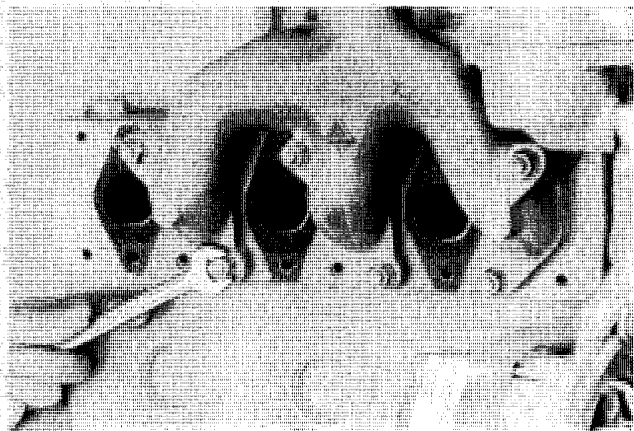

Install and tighten the exhaust manifold bolts.

**STEP 149**



Install the inlet manifold.

**STEP 201**

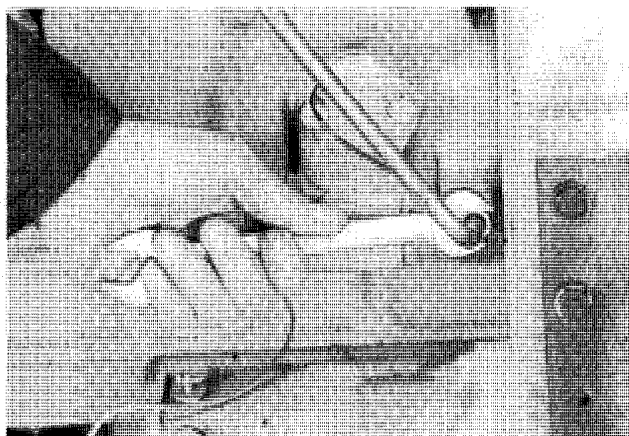

Disconnect the fuel line to the electric transfer pump.

**STEP 202**

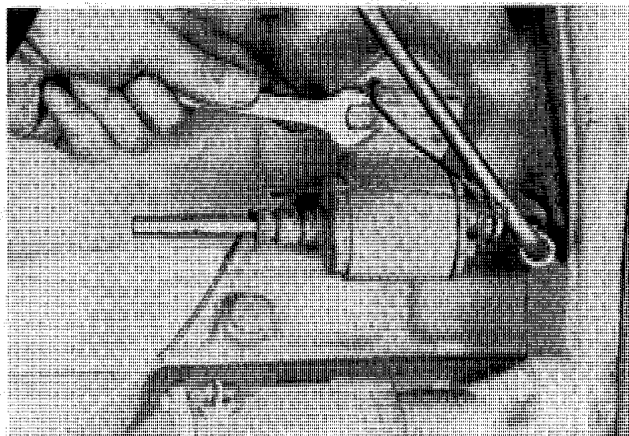

Remove the mounting bolt and ground lead.

**STEP 203**

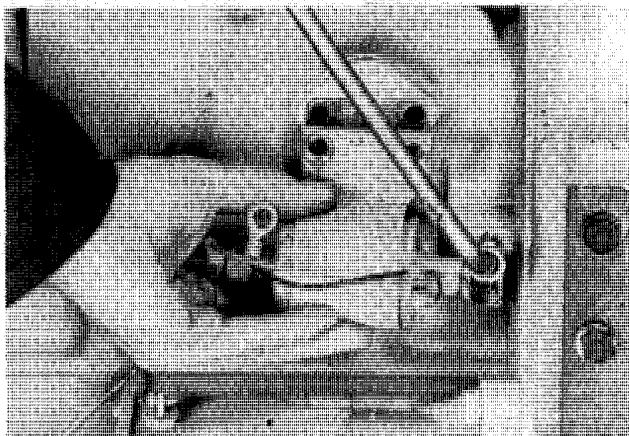

Remove the remaining mounting bolt and remove the transfer pump.

**STEP 204**

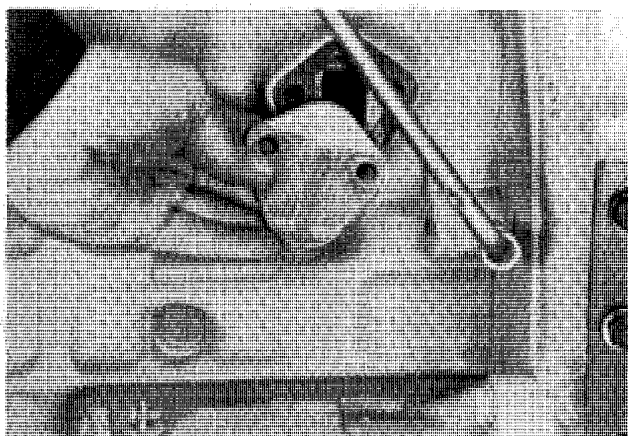

Remove the blanking plate.

**STEP 205**

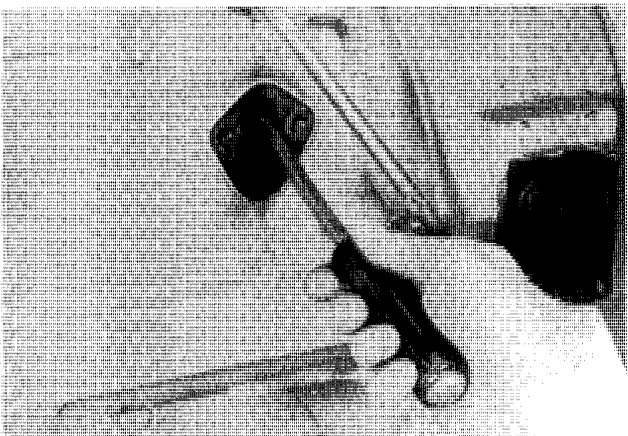

Install a bar through the fuel pump opening to hold the camshaft forward.

**STEP 206**

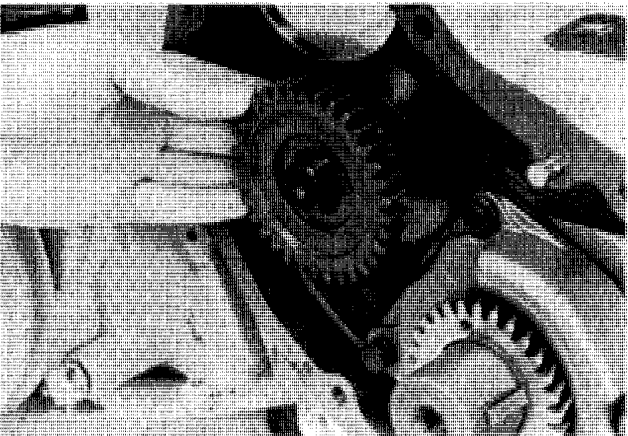

Install the injection pump drive gear.

## SPECIFICATIONS

### Pistons

Cylinder Diameter . . . . .	3.5842 to 3.5827 inch	91.039 to 91.000 mm
Wear Limits - Cylinder Bore . . . . .	0.008 inch	0.020 mm
Piston Pin Hole Diameter . . . . .	1.1253 to 1.1251 inch	28.582 to 28.577 mm
Ring Groove Width - 1 . . . . .	0.0819 to 0.0811 inch	2.080 to 2.060 mm
Max. Wear Limit Width - 1 . . . . .	0.0839 inch	2.131 mm
Ring Groove Width - 2 . . . . .	0.0811 to 0.0803 inch	2.060 to 2.040 mm
Max. Wear Limit Width - 2 . . . . .	0.0831 inch	2.111 mm
Ring Groove Width - 3 . . . . .	0.1590 to 0.1583 inch	4.040 to 4.020 mm
Max. Wear Limit Width - 3 . . . . .	0.1610 inch	4.089 mm
Piston Fit-Feeler Gauge . . . . .	0.003 inch	0.08 mm
Pull Required . . . . .	.5 to 10 lbs	2.3 to 4.5 kg

### Piston Rings

Ring Width - 1 . . . . .	0.078 to 0.077 inch	1.990 to 1.960 mm
Wear Limits - Min. Width . . . . .	0.075 inch	1.905 mm
Ring Width - 2 . . . . .	0.078 to 0.077 inch	1.990 to 1.960 mm
Wear Limits - Min. Width . . . . .	0.075 inch	1.905 mm
Ring Width - 3 . . . . .	0.1578 to 0.1537 inch	4.007 to 3.904 mm
Wear Limits - Min. Width . . . . .	0.1517 inch	3.853 mm
Ring Gap Clear - 1 . . . . .	0.010 to 0.020 inch	0.25 to 0.50 mm
Ring Gap Clear - 2 . . . . .	0.010 to 0.020 inch	0.25 to 0.50 mm
Ring Gap Clear - 3 . . . . .	0.015 to 0.055 inch	0.38 to 1.40 mm
Ring Side Clear - 1 . . . . .	0.0047 to 0.0028 inch	0.120 to 0.070 mm
Ring Side Clear - 2 . . . . .	0.0039 to 0.0020 inch	0.100 to 0.050 mm
Ring Side Clear - 3 . . . . .	0.0054 to 0.0005 inch	0.136 to 0.013 mm

### Connecting Rods

Bush. Hole Diameter . . . . .	1.1880 to 1.1870 inch	30.175 to 30.150 mm
Bearing Hole Diameter . . . . .	2.0620 to 2.0615 inch	52.375 to 52.362 mm
Bearing Thickness . . . . .	0.0617 to 0.0612 inch	1.567 to 1.554 mm
Wear Limits - Min. Thickness . . . . .	0.0607 inch	1.542 mm
Diameter - Crank Pin . . . . .	1.9375 to 1.9365 inch	42.212 to 49.187 mm
Wear Limits - Min. Diameter . . . . .	1.9335 inch	49.162 mm
Clearance Limits . . . . .	0.0031 to 0.0006 inch	0.080 to 0.016 mm
Desired Clearance . . . . .	0.0019 inch	0.048 mm
Wear Limits - Max. Clearance . . . . .	0.0036 inch	0.091 mm
Side Play . . . . .	0.011 to 0.006 inch	0.28 to 0.15 mm
Desired Side Play . . . . .	0.008 inch	0.20 mm

### Piston Pin

Length . . . . .	2.795 to 2.783 inch	71.0 to 70.7 mm
Diameter . . . . .	1.1250 to 1.1248 inch	28.575 to 28.571 mm
Wear Limits - Min. Diameter . . . . .	1.1245 inch	28.562 mm
Desired Fit . . . . .	Light Push	
Bush. Hole Diameter - Fin. . . . .	1.1259 to 1.1255 inch	28.598 to 28.588 mm
Wear Limits - Max. Diameter . . . . .	1.1269 inch	28.623 mm
Pin Clearance in Bushing . . . . .	0.0005 to 0.0011 inch	0.013 to 0.028 mm
Desired Pin Fit . . . . .	0.0008 inch	0.020 mm

## Inspecting The Piston Rings

### STEP 22

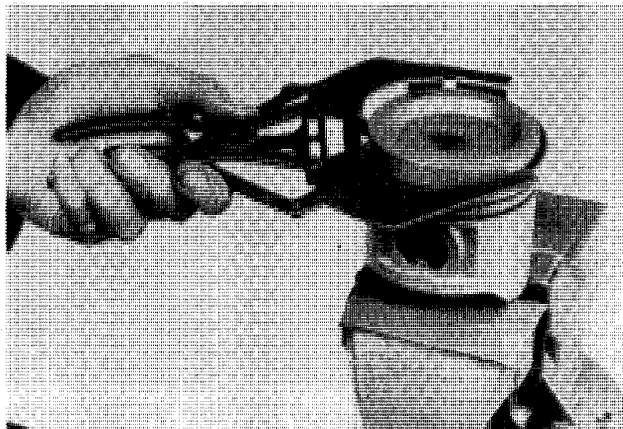

Using a piston ring expander, remove the top compression ring.



**CAUTION:** *DO NOT* over expand the piston rings. Always wear eye protection when removing or installing piston rings.

### STEP 23

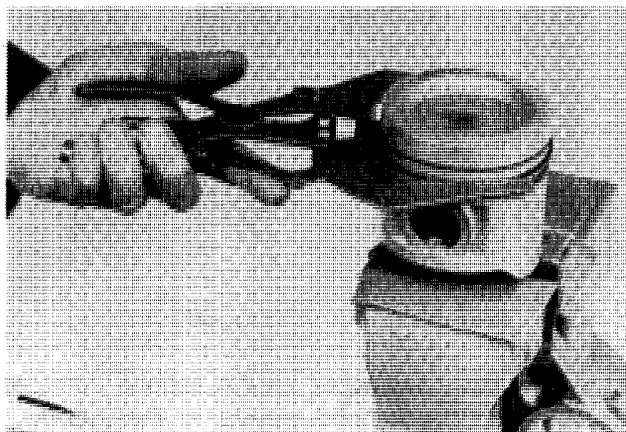

Remove the second compression ring.

### STEP 24

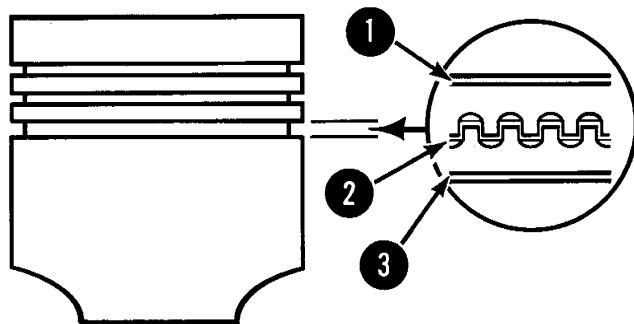

Remove the three oil control rings in the order, as shown.

### STEP 25

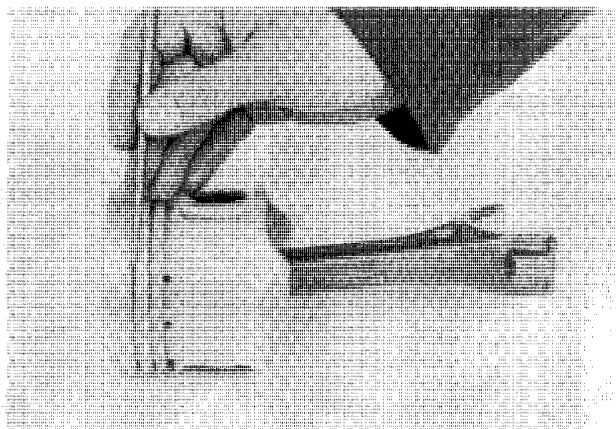

Clean the grooves for the piston rings. Too much carbon deposit in the grooves can force the rings out, causing scoring on the cylinder bores.

### STEP 26

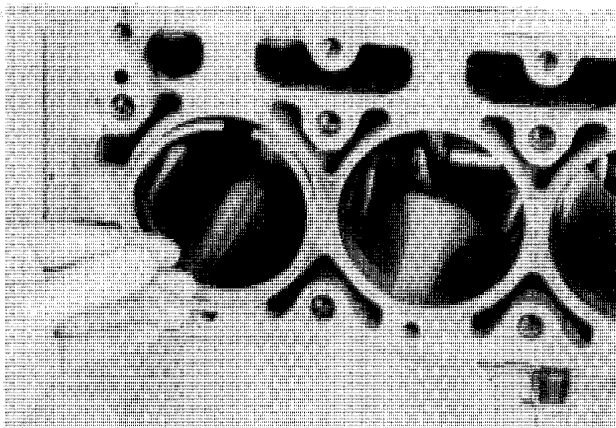

Fit the top compression ring into the cylinder bore. Push the ring into the cylinder bore so that it is 2.0 inch (50 mm) from the top and horizontal.

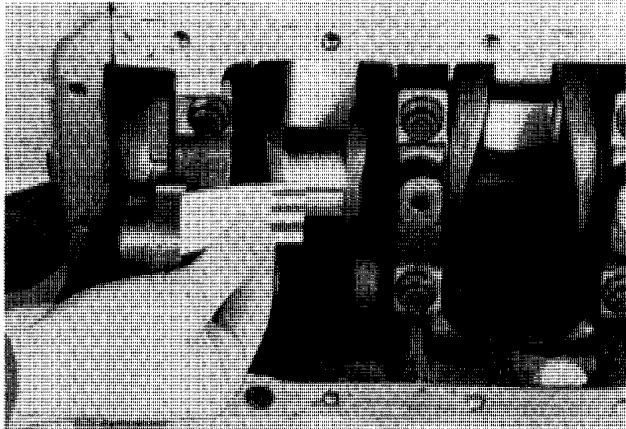
**STEP 62**

Measure the 'Plastigage' with the correct gauge paper to get the clearance between the bearing insert and the crankshaft. The clearance must be 0.003 to 0.0006 inch (0.080 to 0.016 mm). Install new bearing inserts if the clearance is not correct.

**NOTE:** If the clearance is still not correct after installing new bearing inserts, refer to Section 2035 to service the crankshaft.

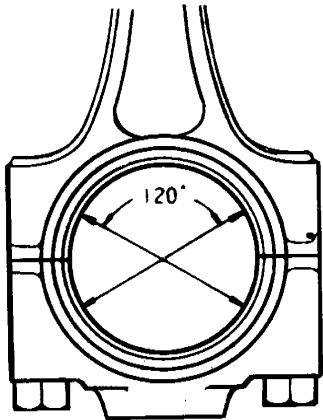
**STEP 63**

Repeat the procedure in the other three positions on the bearing inserts as shown.

**NOTE:** Make sure the 'Plastigage' does not go across the lubrication hole in the crankshaft.

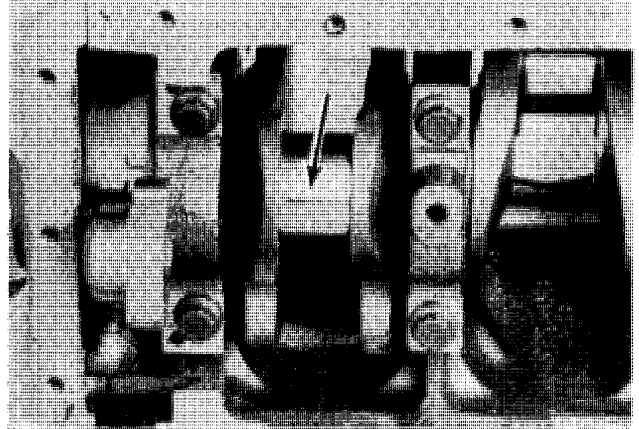
**STEP 64**

If the clearance is correct, remove the 'Plastigage'.

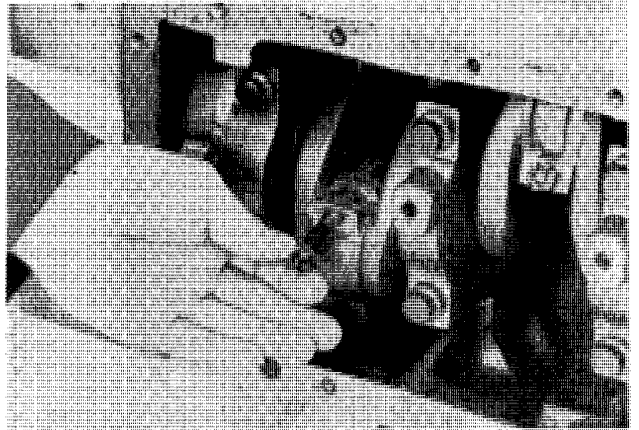
**STEP 65**

Lubricate the bearing inserts with clean engine oil. Fit the end cap onto the crankshaft and connecting rod.

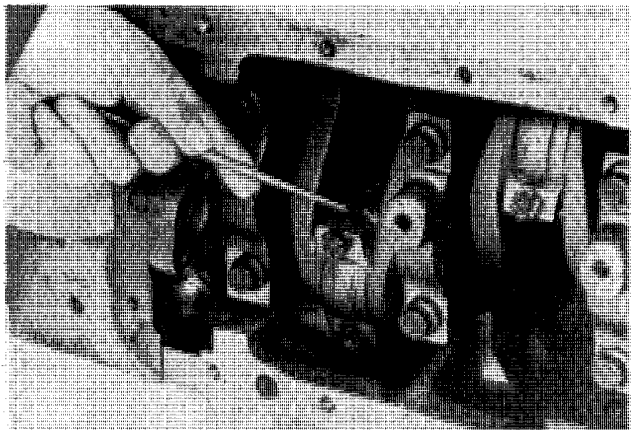
**STEP 66**

Check the identification numbers on the end cap and connecting rod are in alignment.

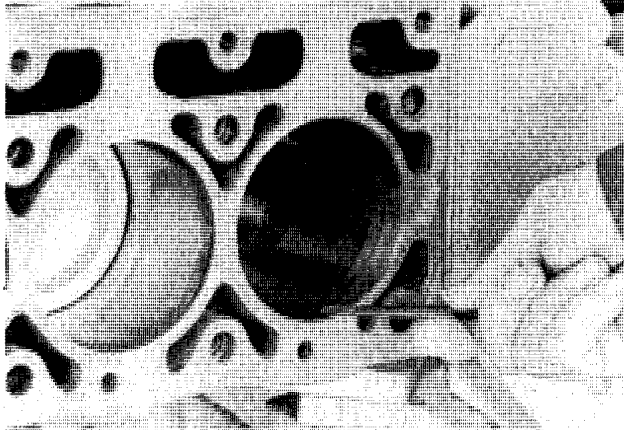
**STEP 6**

Remove the carbon from the top of the cylinder bores. Check the bore walls for a ridge at the top of the piston ring movement zone. A ridge will cause damage to the piston during removal. If a ridge is present, remove it with a suitable ridge reamer.

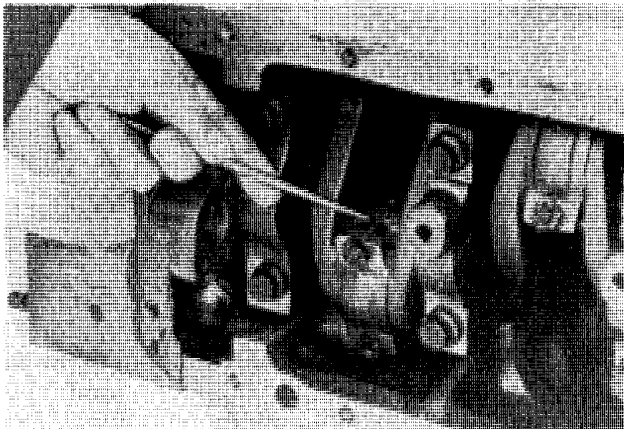
**STEP 7**

Look for identification numbers on the connecting rods and end caps. Use these numbers to install and assemble the parts in the correct position. If there are no numbers, put identification marks on the connecting rods and end caps.

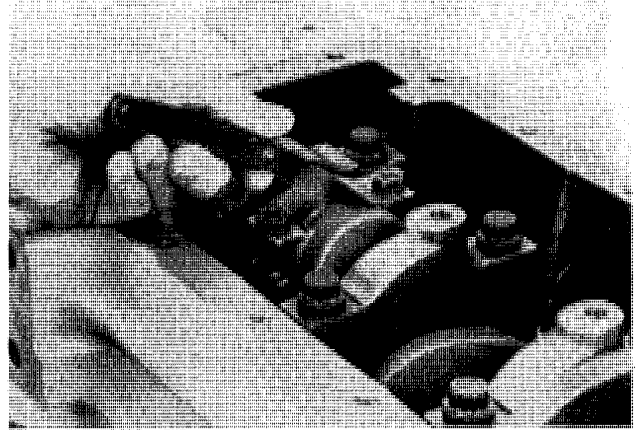
**STEP 8**

Install a feeler gauge in between the connecting rod and the crankshaft and check the connecting rod end play. The correct end play is 0.008 inch (0.20 mm).

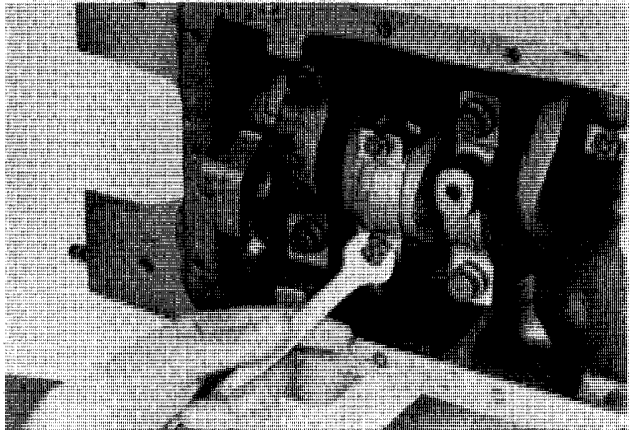
**STEP 9**

Remove the bolts from the end cap.

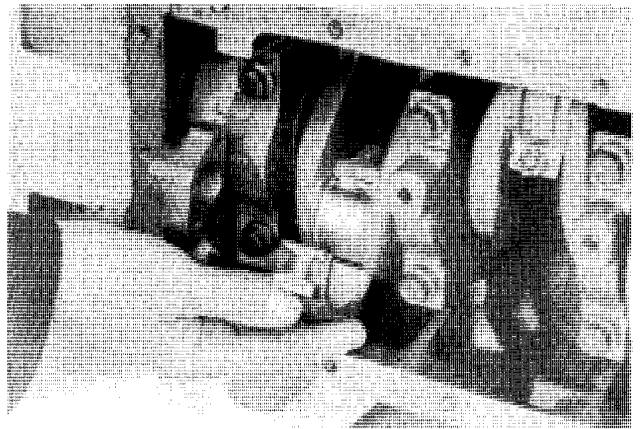
**STEP 10**

Remove the end cap.

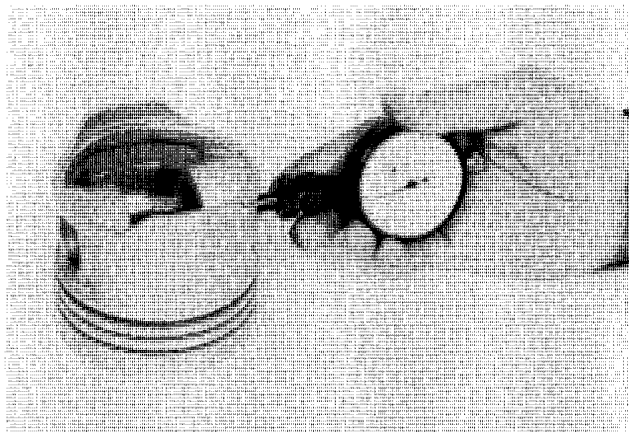
**STEP 39**

Measure the hole for the piston pin in the piston. The diameter must be 1.1253 to 1.1251 inch (28.582 to 28.577 mm). Install a new piston if the diameter is more than 1.1253 inch (28.582 mm).

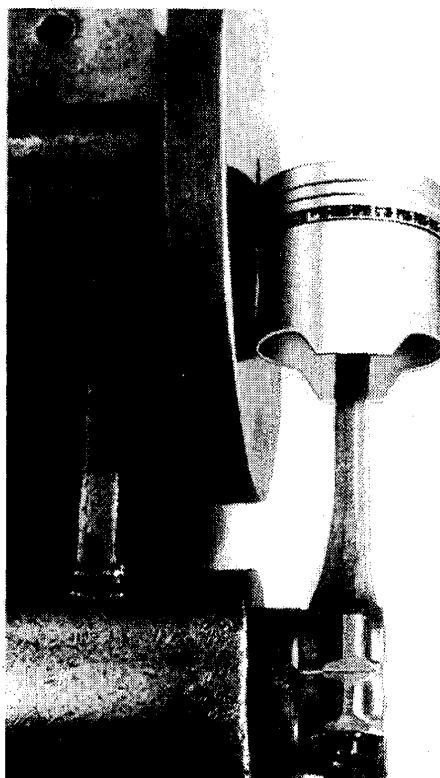
**STEP 40**

Check the connecting rod for twist and alignment. This may be checked on a fixture with the piston pin assembled in the rod before assembling the piston; but regardless of this preliminary check the complete piston and rod assembly must be checked again and there must not be more than 0.002 inch (0.05 mm) twist or out of squareness checked over a spread of approximately 4.0 inches (100 mm). Replace the connecting rod if the measurement does not meet specifications.

**NOTE:** *Pistons are cam and taper ground and this must be taken into consideration when checking alignment of the assembly, since the diameter in line with the piston pin would be less at the top of the skirt than the bottom.*

# **Section 2035**

**CRANKSHAFT, MAIN BEARINGS,  
FLYWHEEL AND OIL SEALS**

**TM20 Gasoline Engine**

**STEP 21**

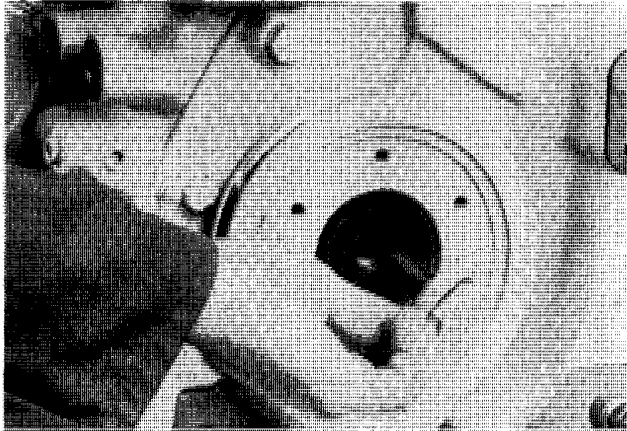

Remove the bolt and washer.

**STEP 23**

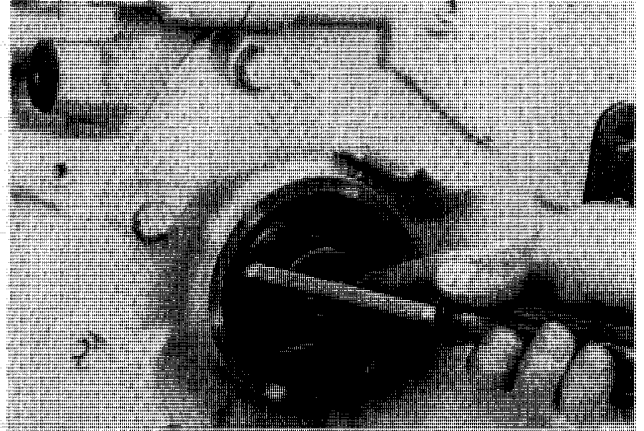

Remove the oil seal.

**STEP 22**

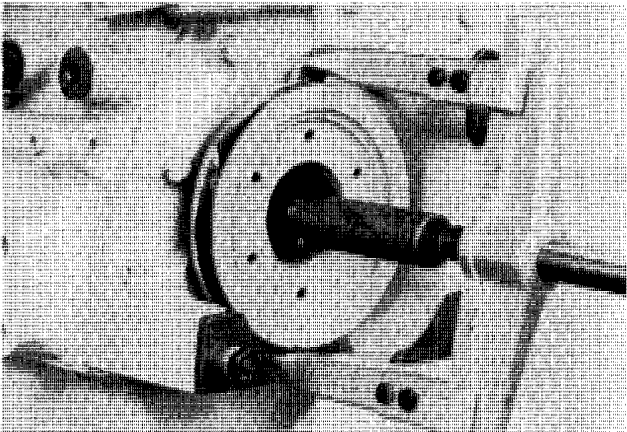

Use a suitable puller and remove the crankshaft pulley.

**STEP 68**

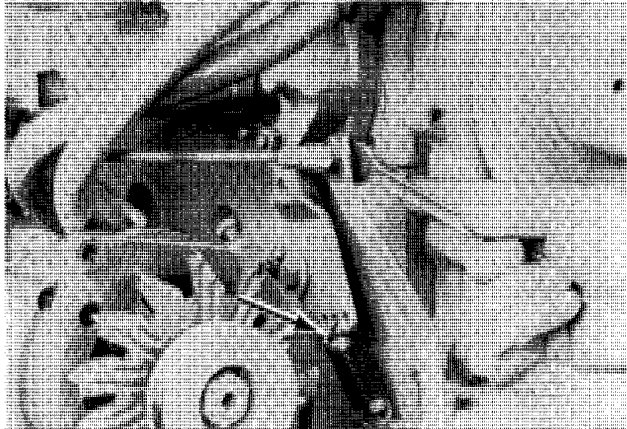

Disconnect the governor linkage and spring.

**STEP 69**

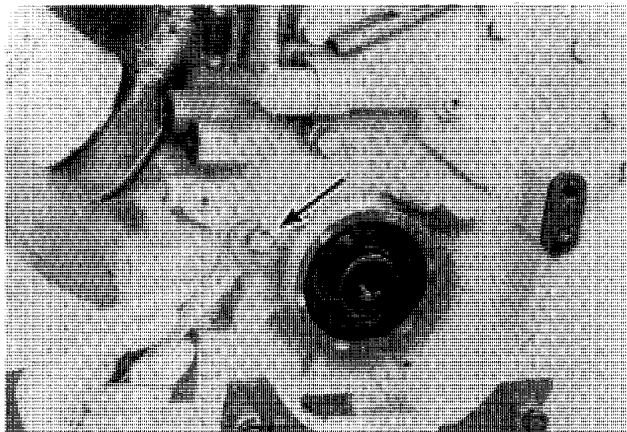

Remove the timing cover bolts.

**NOTE:** *The arrowed bolt has a copper washer, the remaining bolts are fitted with spring washers.*

**STEP 70**



Remove the timing cover.

**STEP 71**

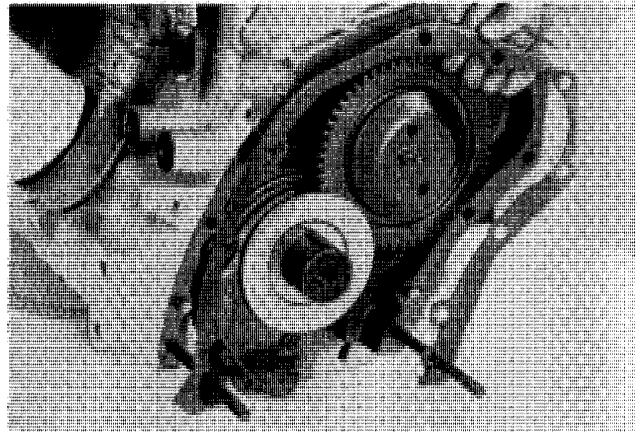

Remove the gasket.

**STEP 72**

Remove the camshaft gear and oil pump. See section 2045.

**STEP 73**

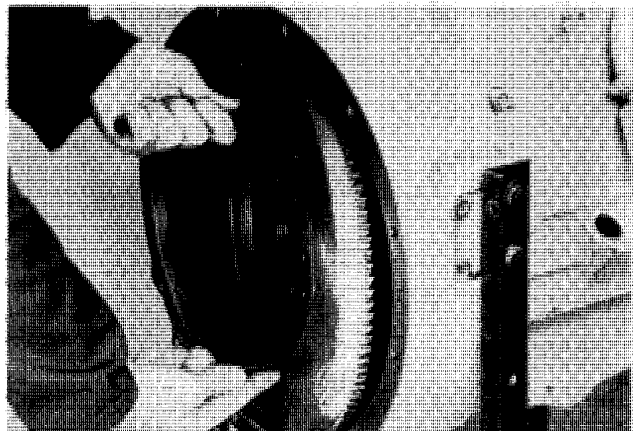

Remove the flywheel. See STEPS 6 to 8 of this section.

**STEP 74**

Remove the starter motor. See section 4006 of this manual.

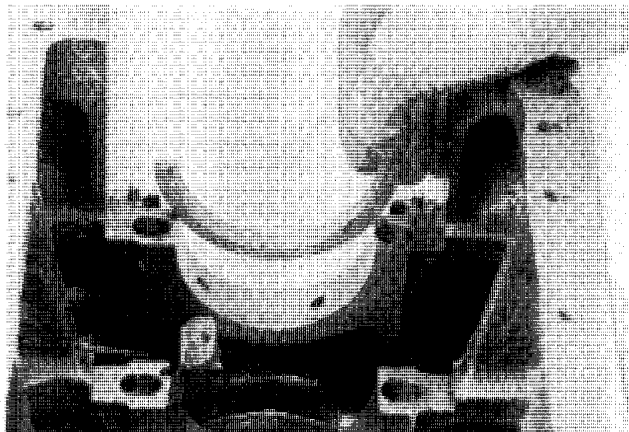
**STEP 109**

Apply petroleum jelly to a new upper seal and install around the crankshaft into the groove in the crankcase making sure the seal lip is towards the engine.

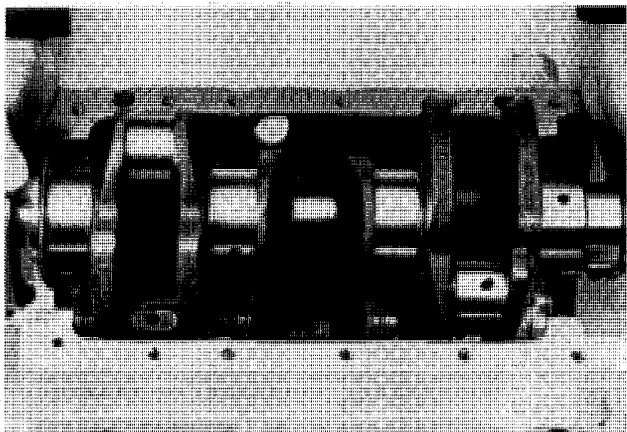
**STEP 110**

Lubricate the bearing inserts with clean engine oil and install the crankshaft.

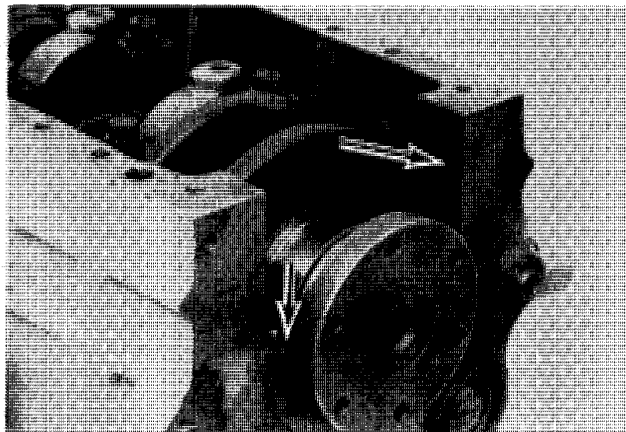
**STEP 111**

Thoroughly clean the crankcase bearing block walls and dowel area.

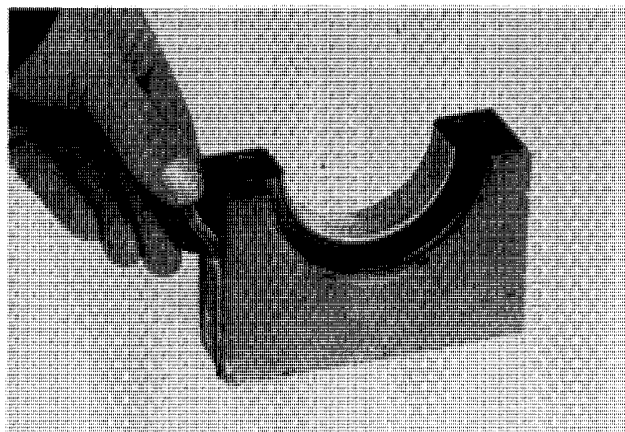
**STEP 112**

Remove the old sealing material from the channels in the oil seal bearing block. Thoroughly clean the bearing block walls and dowel area.

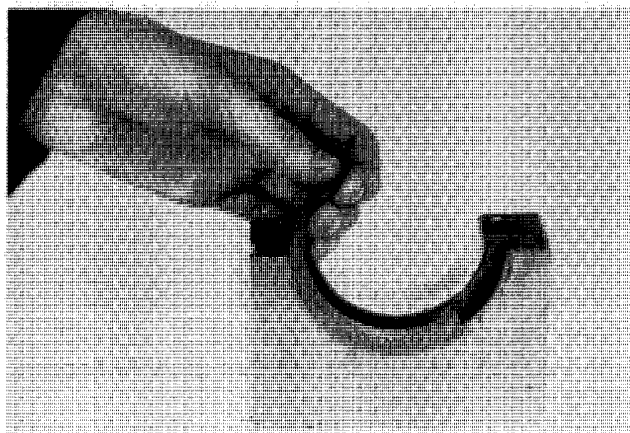
**STEP 113**

Apply petroleum jelly to a new lower seal and install into the main bearing block making sure the seal lip is towards the engine.

# SPECIAL TOOLS

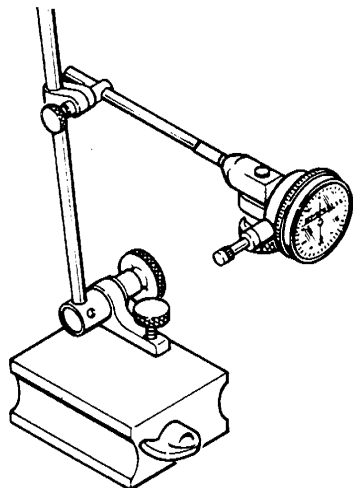

**1. DIAL GAUGE**

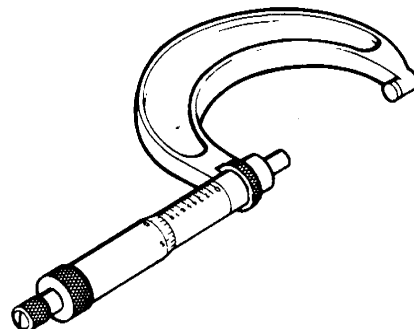

**4. MICROMETER**  
0 to 1 INCH (0 to 25 MM)  
1 to 2 INCH (25 to 50 MM)  
2 to 3 INCH (50 to 75 MM)

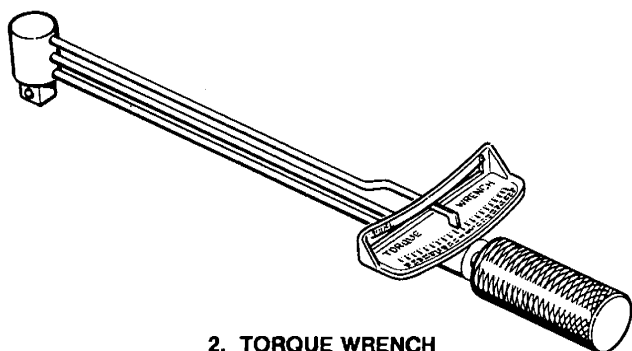

**2. TORQUE WRENCH**

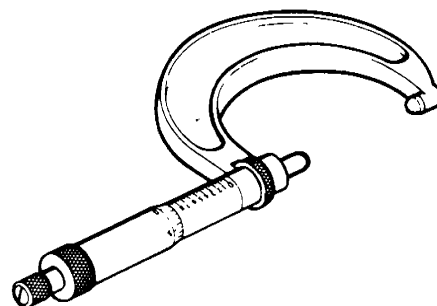

**5. BALL TYPE MICROMETER**  
0 to 1 INCH (0 to 25 MM)

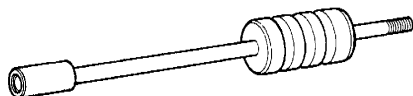

**3. IMPULSE EXTRACTOR**

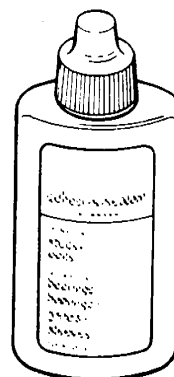

**6. SEAL KIT (No 1959746C1)**

**STEP 39**



Install an impulse extractor with the correct thread into the main bearing block.

**STEP 40**

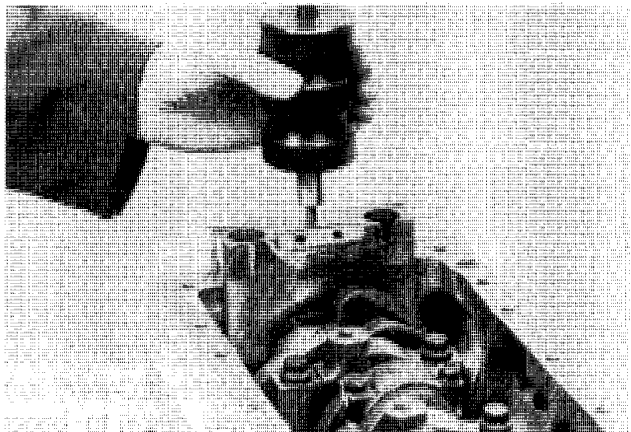

Operate the impulse extractor and remove the main bearing block.

**STEP 41**

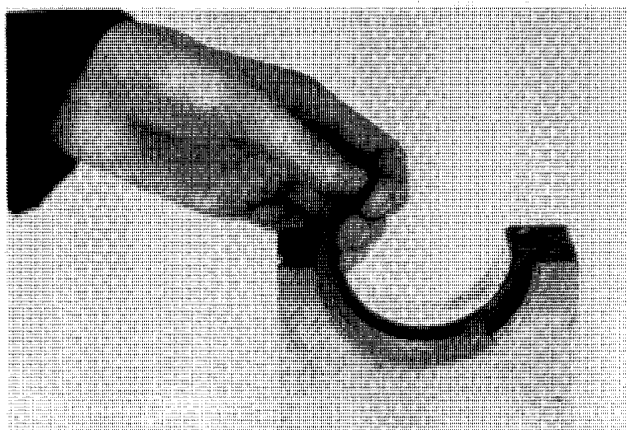

Remove the lower seal from the bearing block.

**STEP 42**

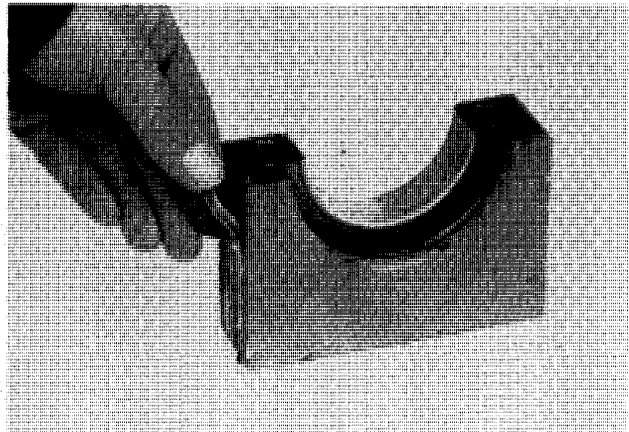

Remove the old sealing material from the channels in the bearing block and thoroughly clean the bearing block walls and dowel area.

**STEP 43**

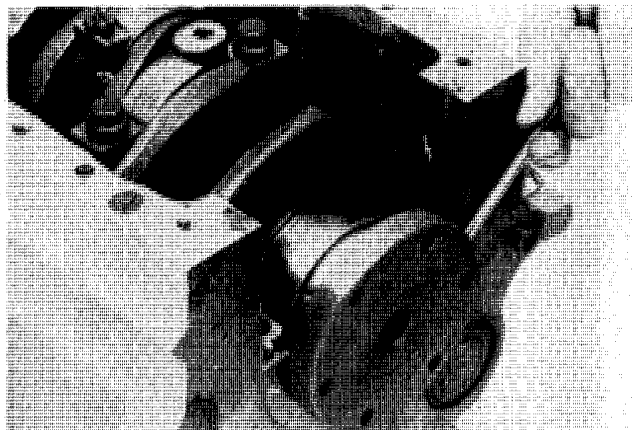

Push the upper seal from the crankcase.

**STEP 44**

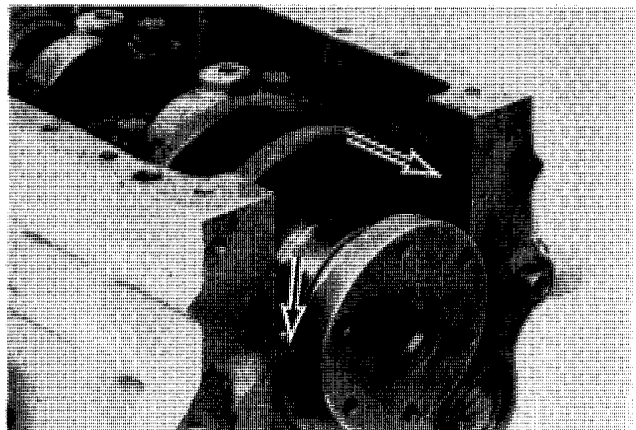

Thoroughly clean the crankcase bearing block walls and dowel area.

**STEP 93**

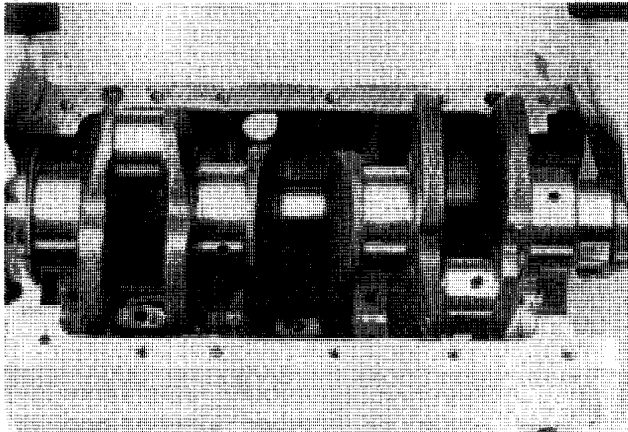

Remove the crankshaft.

**STEP 94**

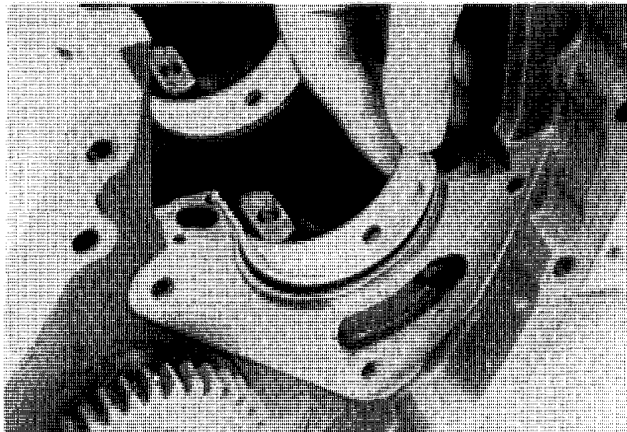

Remove the bearing inserts.

**NOTE:** *Bearing Caps and inserts must be kept together to make sure of correct assembly.*

**STEP 95**

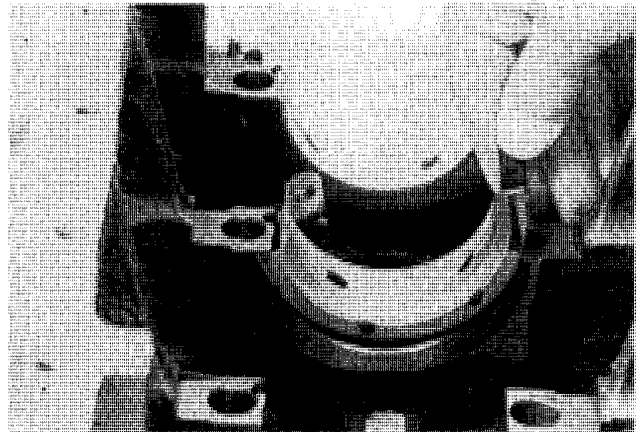

Remove the thrust bearing insert.

**NOTE:** *Bearing Caps and inserts must be kept together to make sure of correct assembly.*

**STEP 96**

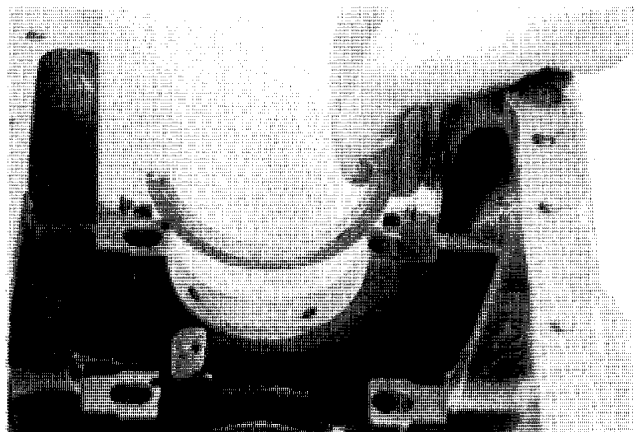

Remove the crankshaft upper oil seal from the crankcase.

**STEP 133**

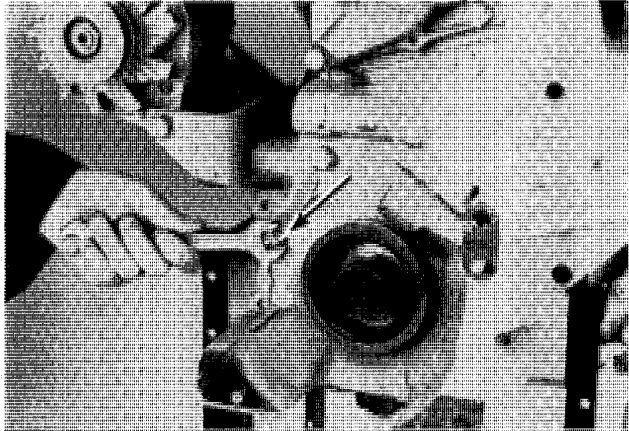

Install and tighten the timing cover bolts.

**NOTE:** *The arrowed bolt is installed with a copper sealing washer.*

**STEP 134**

Install the injection pump. See Section 3312.

**STEP 135**

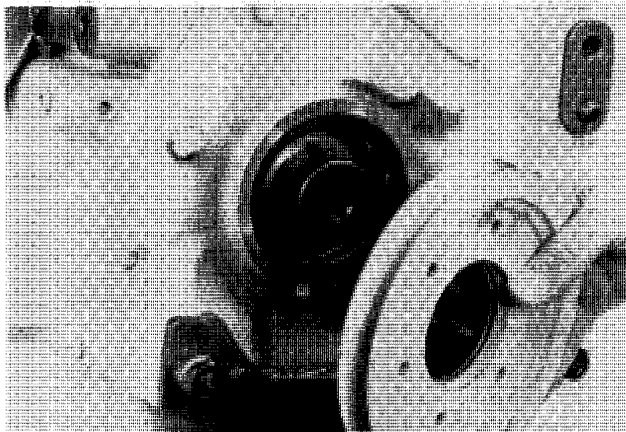

Install the front crankshaft pulley.

**STEP 136**

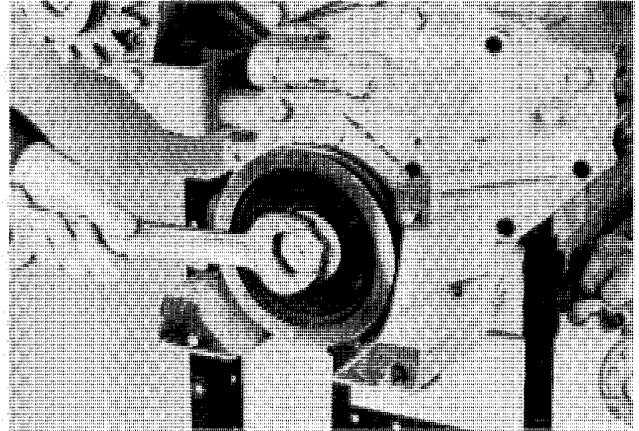

Install the washer and bolt. Tighten the bolt to a torque of 120 to 130 lb ft (163 to 176 Nm).

**STEP 137**

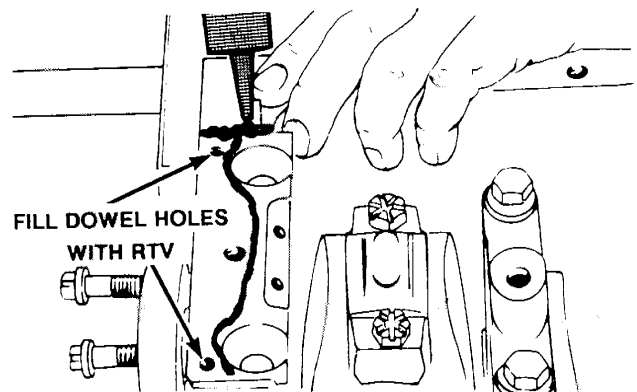
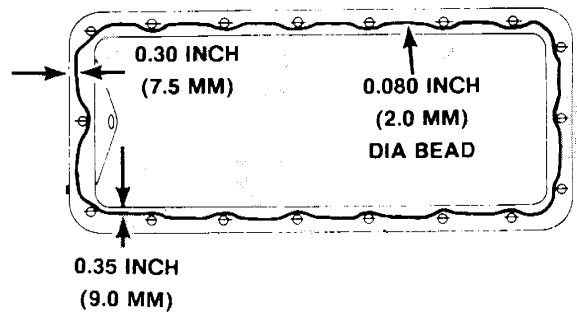

Clean the oil pan mounting faces and apply a bead of RTV sealant 1959746C1 to the oil pan sealing face and bearing cap as shown.

**NOTE:** *The oil pan must be installed to the engine within 20 minutes of applying the sealant.*

**CAUTION:** *Care must be taken when handling RTV sealant. Read the instructions on the sealant container.*

**STEP 25**

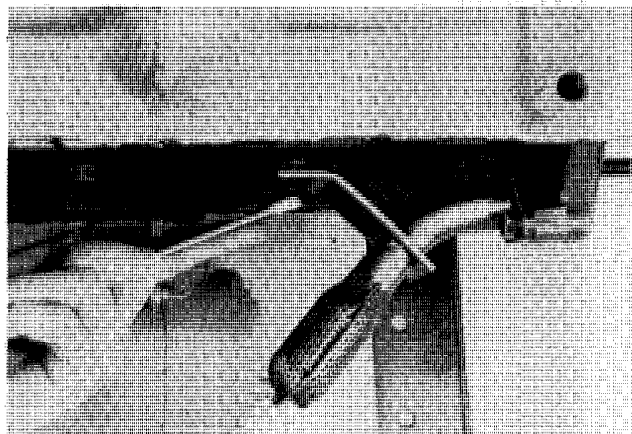

Remove the oil suction pipe retaining bolt.

**STEP 26**

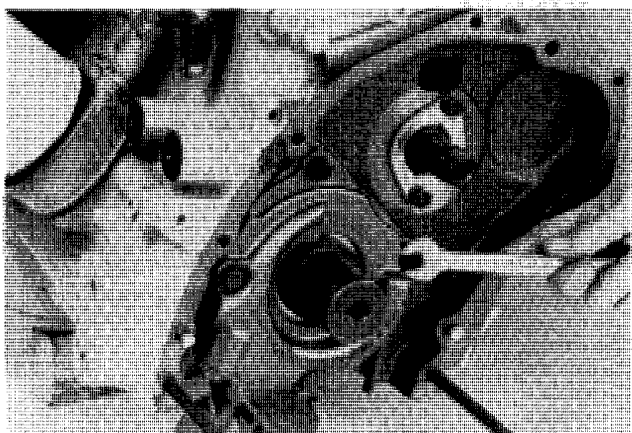

Remove the oil pump retaining bolts.

**STEP 27**

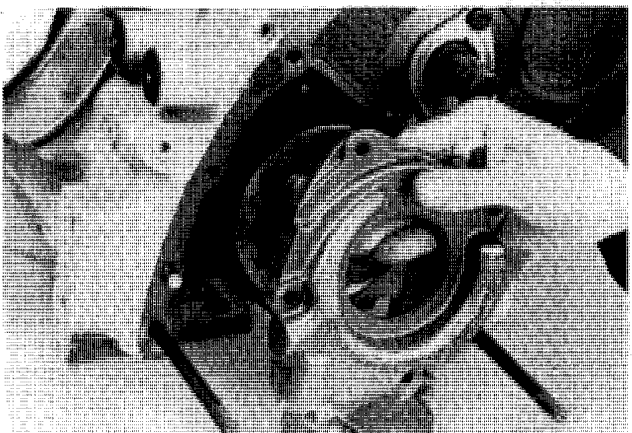

Remove the oil pump housing and suction pipe.

**STEP 28**

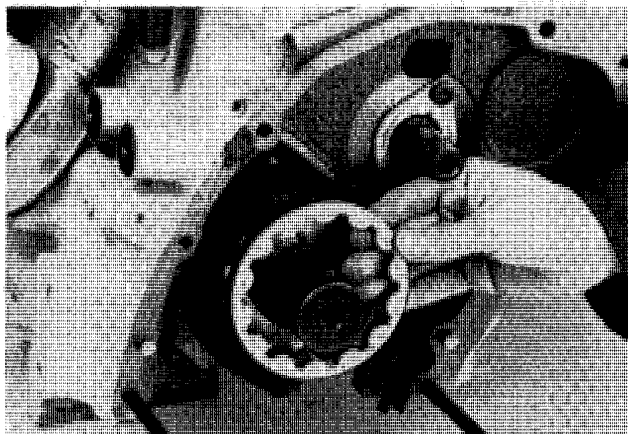

Remove the outer impeller.

**STEP 29**

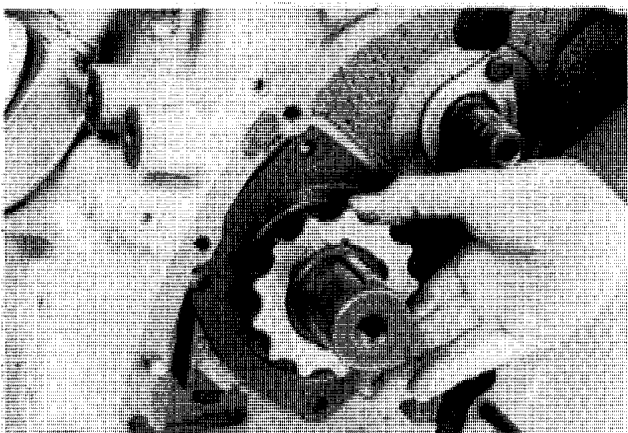

Remove the inner impeller.

**STEP 30**

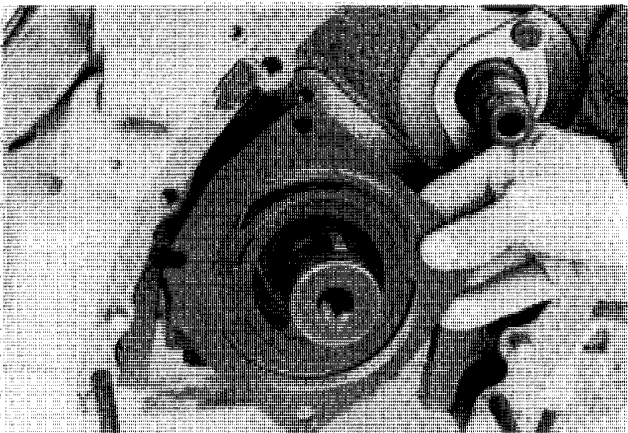

Remove the rear cover.

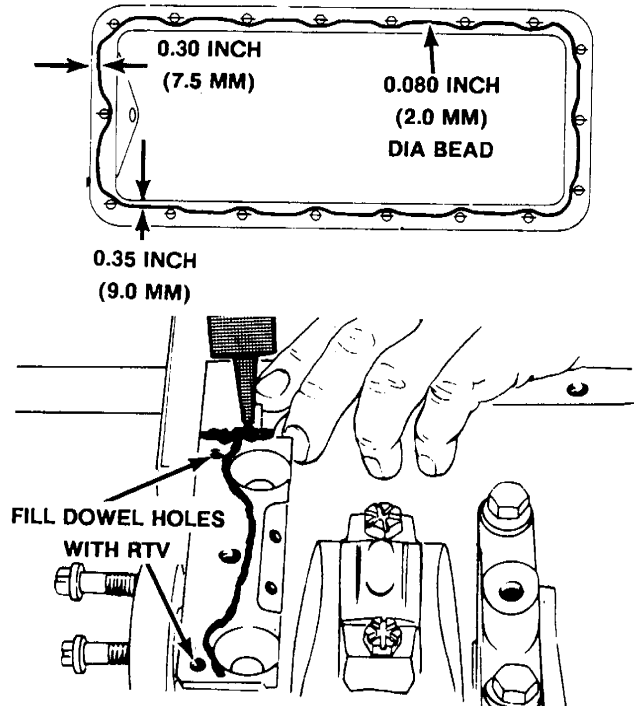
**STEP 74**

Clean the oil pan mounting faces and apply a bead of RTV sealant 1959746C1 to the oil pan sealing face and bearing cap as shown.

**NOTE:** *The oil pan must be assembled to the engine within 20 minutes of applying the sealant.*

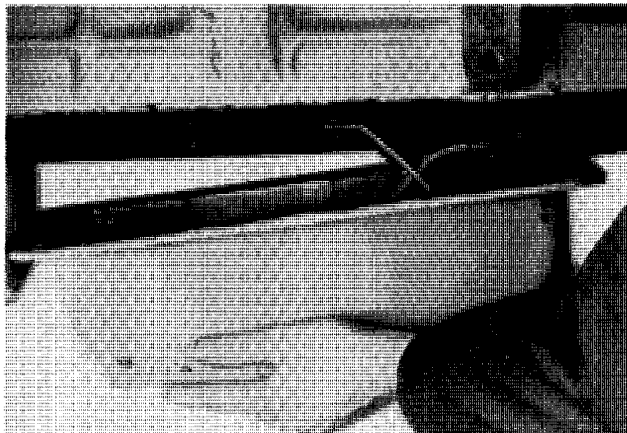

**CAUTION:** *Care must be taken when handling RTV sealant. Read the instructions on the sealant container.*

**STEP 75**

Install the engine oil pan.

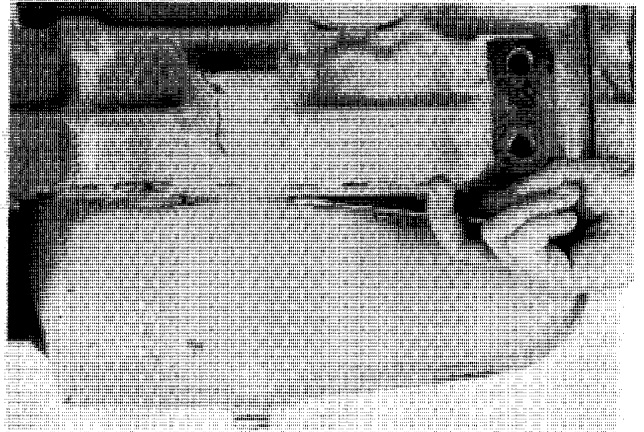
**STEP 76**

Install and tighten the oil pan mounting bolts to a torque of 10 to 14 lb ft (14 to 19 Nm).

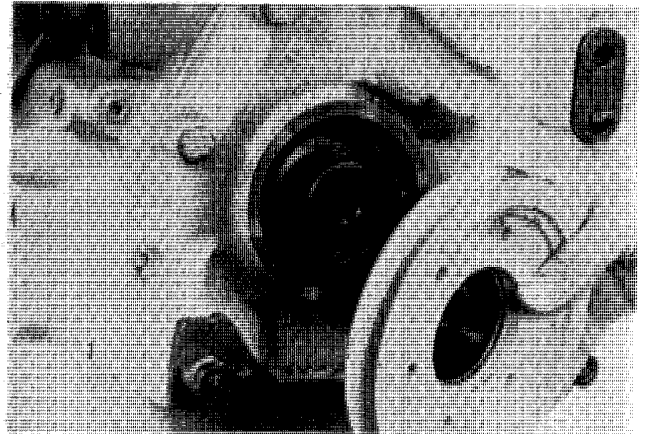
**STEP 77**

Install the crankshaft pulley.

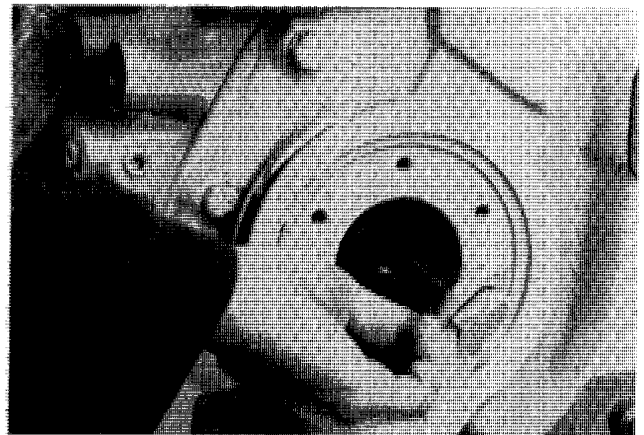
**STEP 78**

Install the crankshaft securing bolt and washer.

**STEP 14**

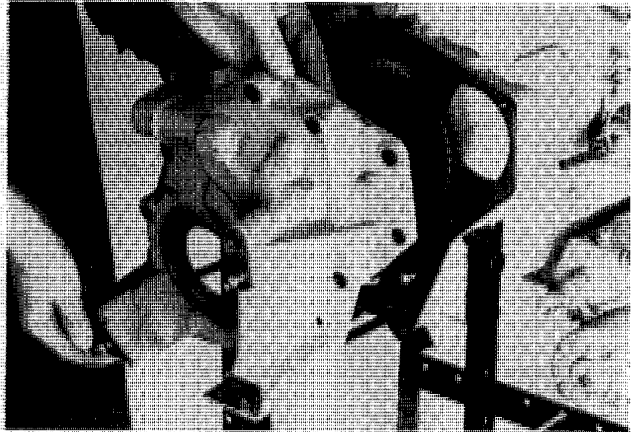

Remove the timing cover.

**STEP 15**

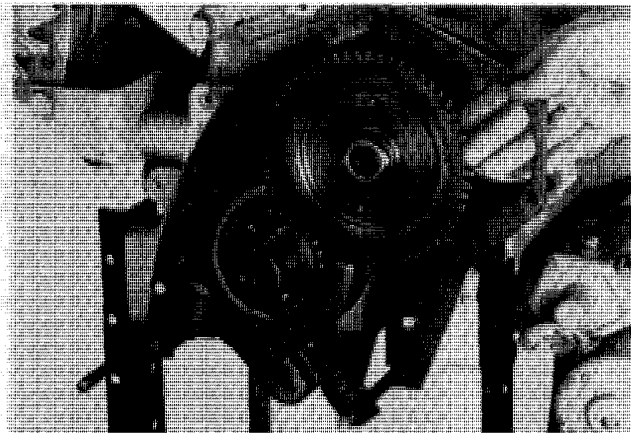

Remove the gasket.

**STEP 16**

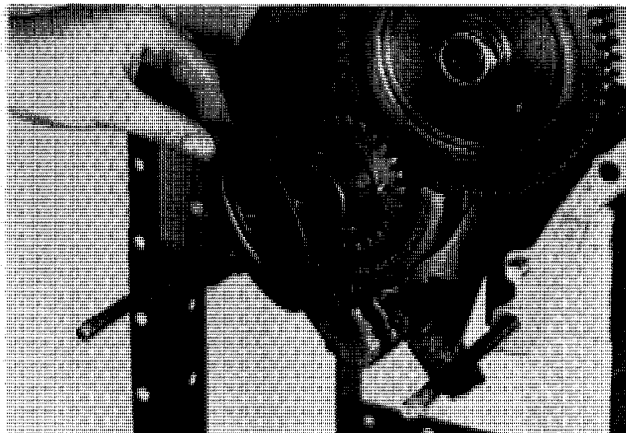

Remove the oil slinger plate.

**STEP 17**

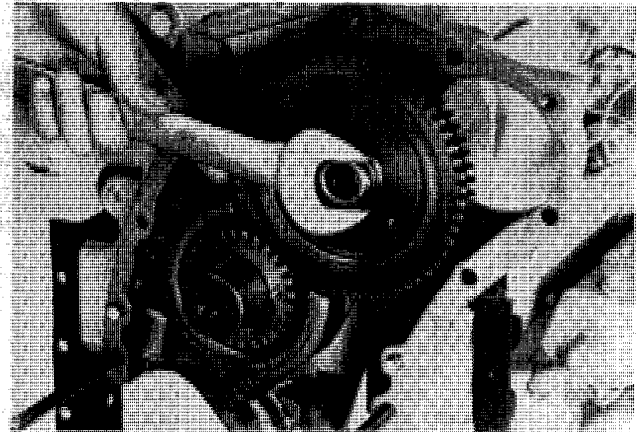

Remove the camshaft gear retaining nut.

**NOTE:** *The camshaft gear retaining nut must be replaced on assembly with a new one.*

**STEP 18**

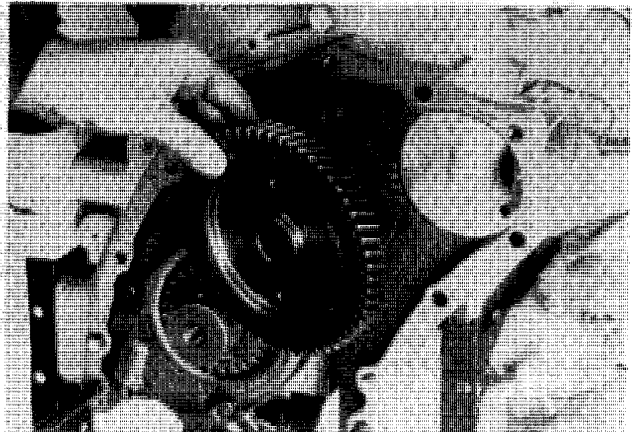

Remove the camshaft gear.

**STEP 19**

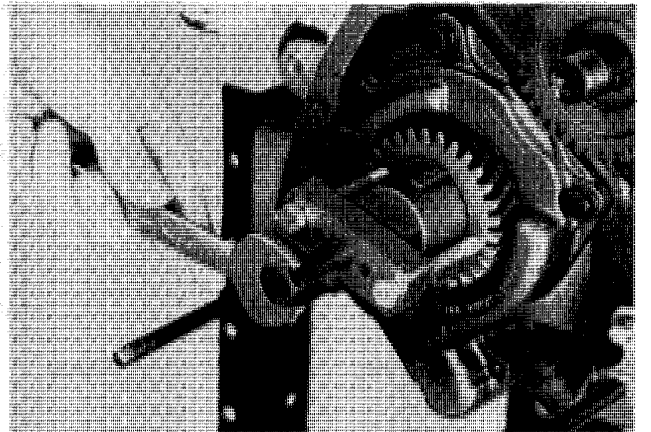

Make the special tool to remove the crankshaft gear. See Special Tools to be Made. Install onto the crankshaft gear and remove the crankshaft gear.

**STEP 71**

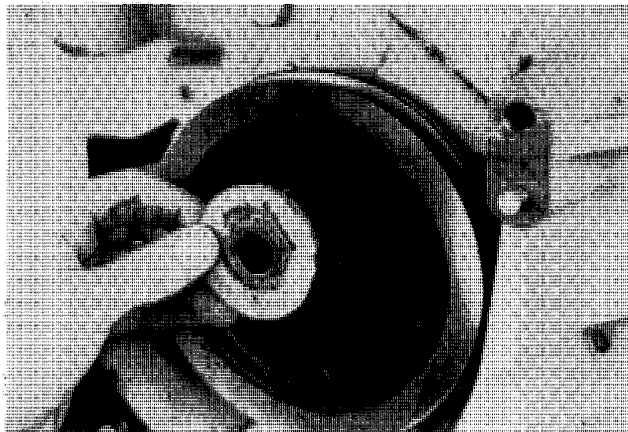

Install the washer.

**STEP 72**

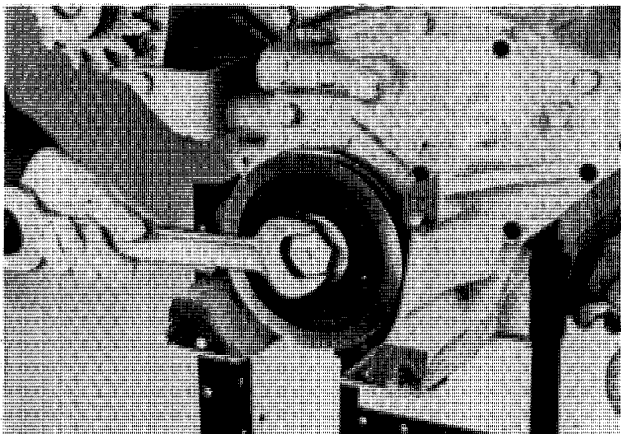

Install and tighten the retaining bolt to 120 to 130 lb ft (163 to 176 Nm).

**STEP 73**

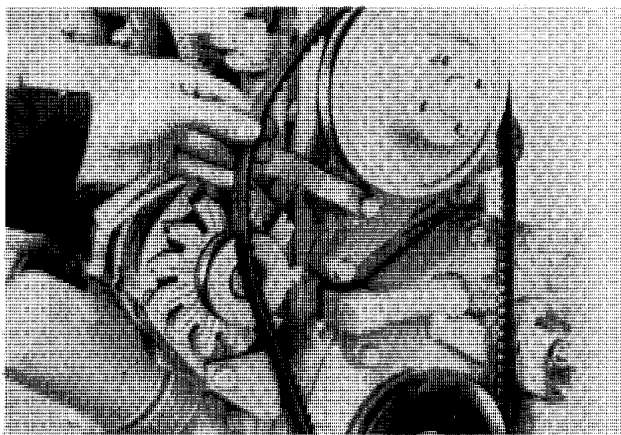

Install the alternator drive belt making sure it fits over the crankshaft pulley, water pump pulley and alternator pulley.

**STEP 74**

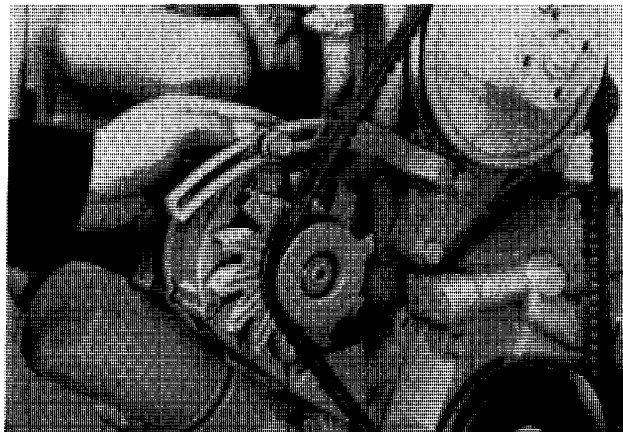

Pull the alternator away from the engine to tension the drive belt.

**STEP 75**

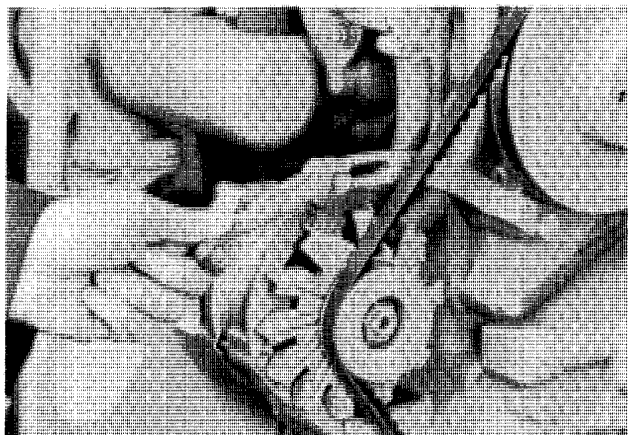

Tighten the adjusting strap bolt.

**STEP 76**

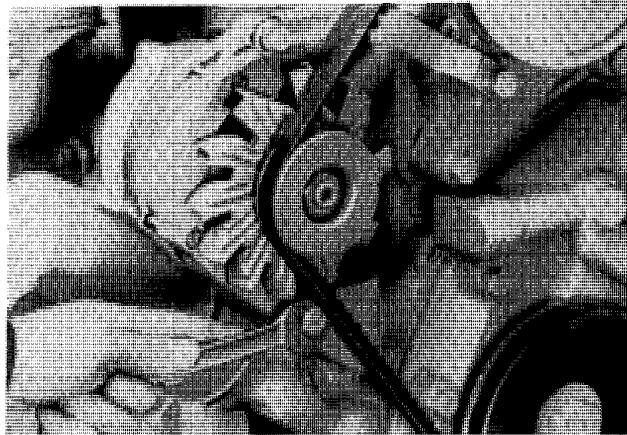

Tighten the alternator mounting bolts.

**STEP 27**

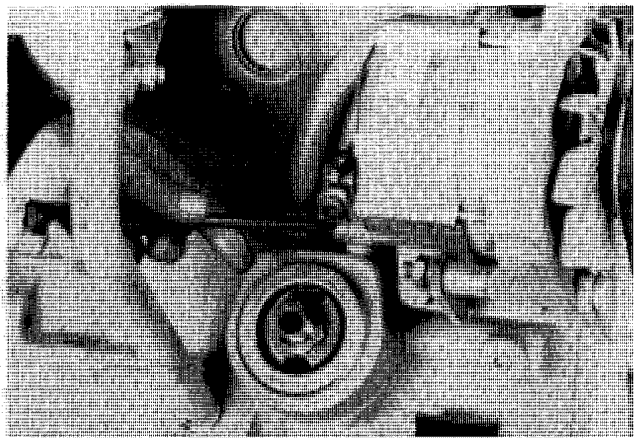

Tighten the water outlet hose clamp.

**STEP 28**

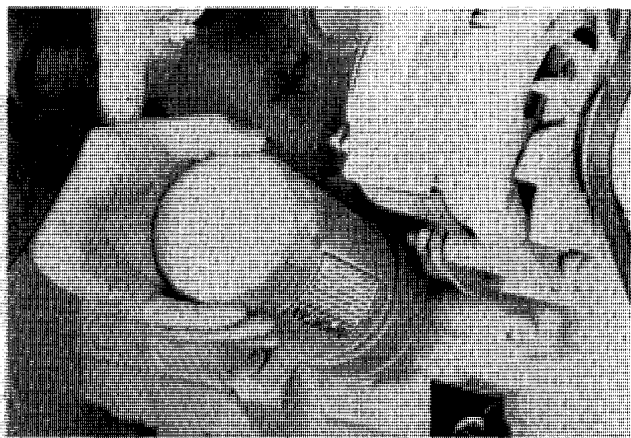

Install the engine oil filter.

**NOTE:** *Install the filter until the seal contacts the sealing face, then tighten a further 3/4 of a turn. Use a strap wrench if necessary.*

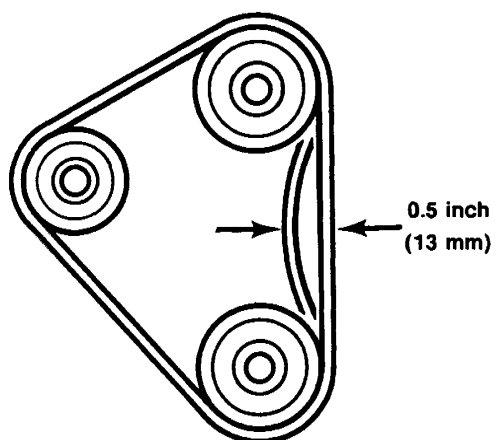
**STEP 81**

Adjust the drive belt tension until there is 0.5 inch (13 mm) deflection at its longest length.

**NOTE:** *The Case Company reserves the right to make improvements in design or changes in specifications at any time without incurring any obligation to install them on units previously sold.*

**STEP 27**

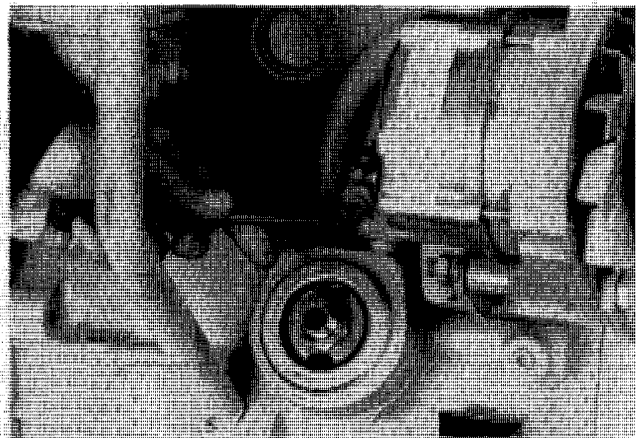

Tighten the water inlet hose clamp.

**STEP 28**

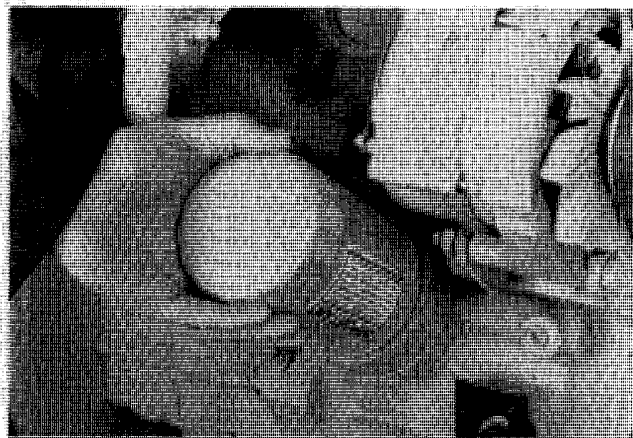

Install the engine oil filter.

**NOTE:** *Install the filter until the seal contacts the sealing face, then tighten a further 3/4 of a turn using a strap wrench if necessary.*

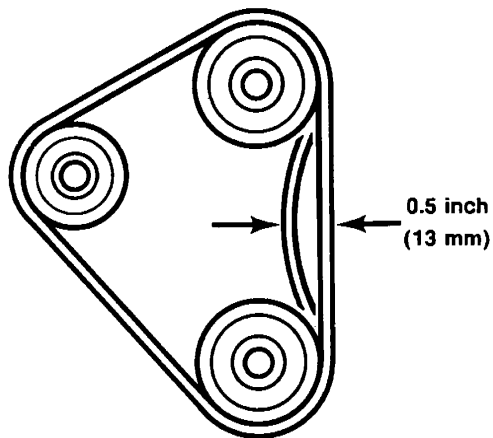
**STEP 81**

Adjust the drive belt tension until there is 0.5 inch (13 mm) deflection at its longest length.

**NOTE:** *The Case Company reserves the right to make improvements in design or changes in specifications at any time without incurring any obligation to install them on units previously sold.*

## ENGINE OIL FILTER SERVICING

### STEP 1

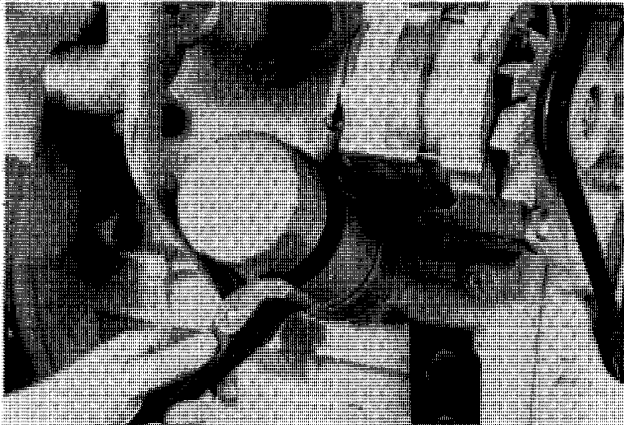

Remove the engine oil filter cartridge using a strap wrench.

### STEP 2

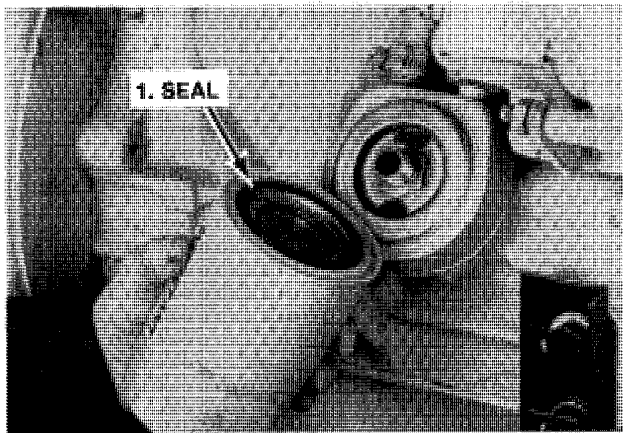

Install a new seal into the new filter.

### STEP 3

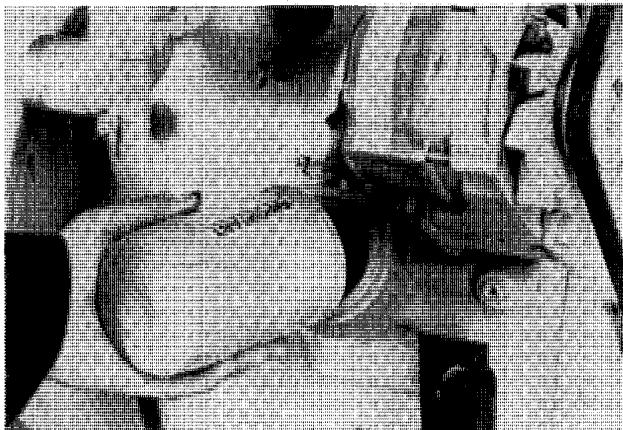

Install the filter.

### STEP 4

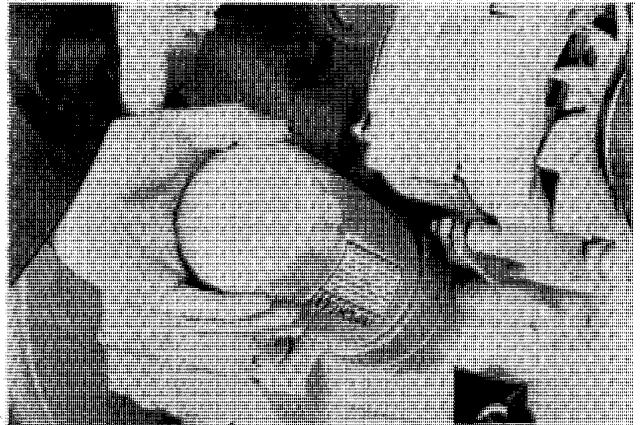

Hand tighten the filter until the seal touches the sealing face.

### STEP 5

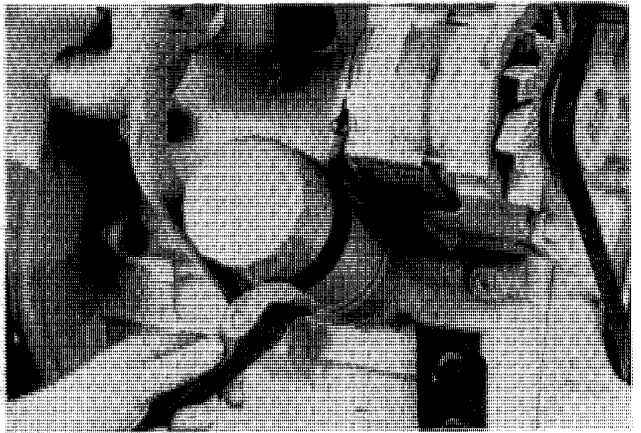

Tighten the filter 3/4 of a turn.

CLICK HERE TO **DOWNLOAD** THE COMPLETE MANUAL

- Thank you very much for reading the preview of the manual.
- You can download the complete manual from: [www.heydownloads.com](http://www.heydownloads.com) by clicking the link below



- Please note: If there is no response to CLICKING the link, please download this PDF first and then click on it.

CLICK HERE TO **DOWNLOAD** THE COMPLETE MANUAL

## IGNITION COIL Removal, Inspection And Installation

### STEP 1

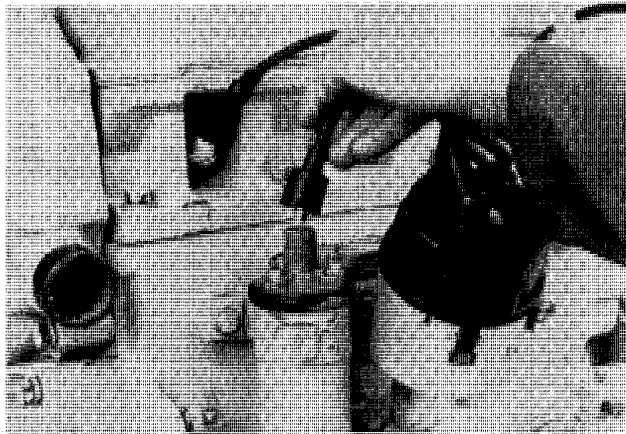

Remove the high tension cable from the ignition coil.

### STEP 2

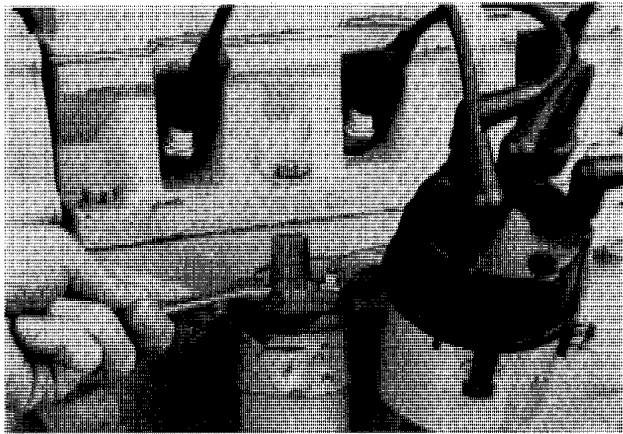

Remove the (+) positive lead from the coil.

### STEP 3

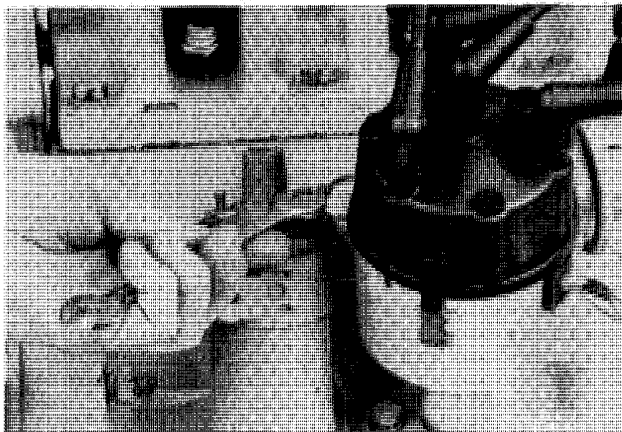

Remove the (-) negative lead from the coil.

### STEP 4

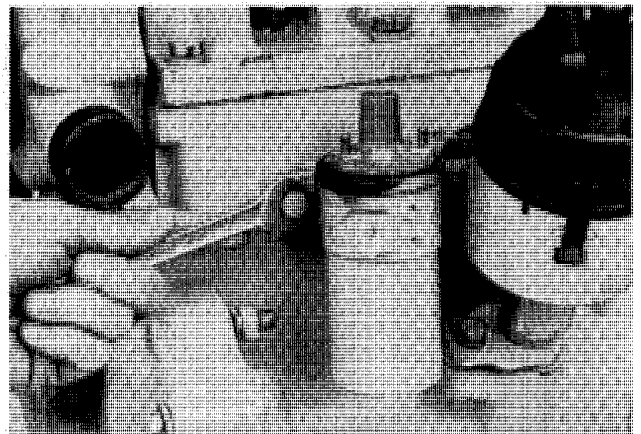

Remove the coil mounting bracket bolts.

### STEP 5

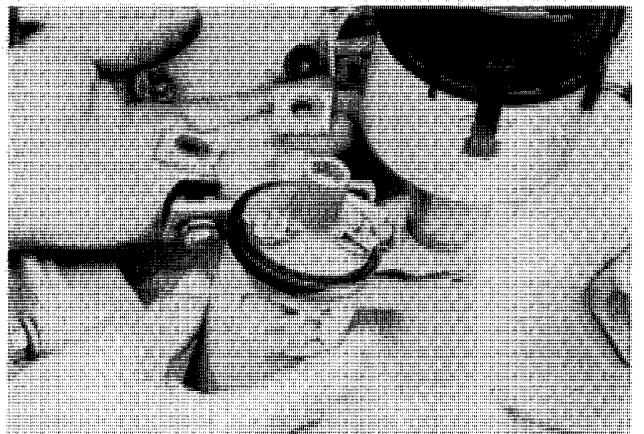

Remove the coil and spacers from the engine.

## Inspection

**NOTE:** If the electronic control system is found faulty follows steps 48 to 54.

### STEP 48

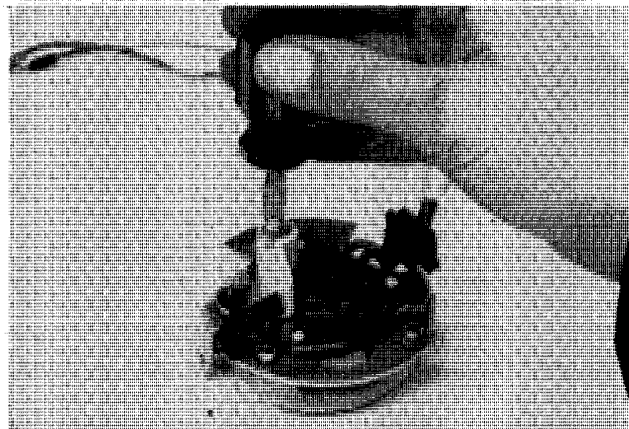

Remove the sensor securing screw.

### STEP 49

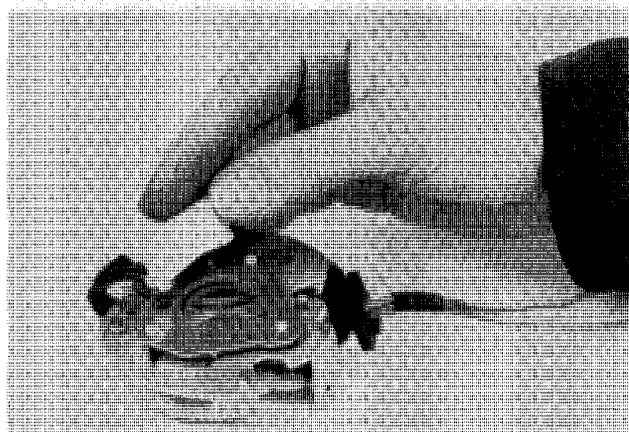

Move the sensor clear of the base plate.

### STEP 50

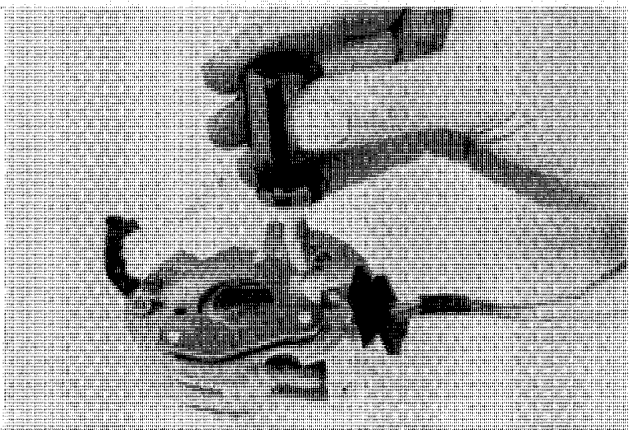

Push round the top half of the base plate and remove the three base plate retaining screws.

### STEP 51

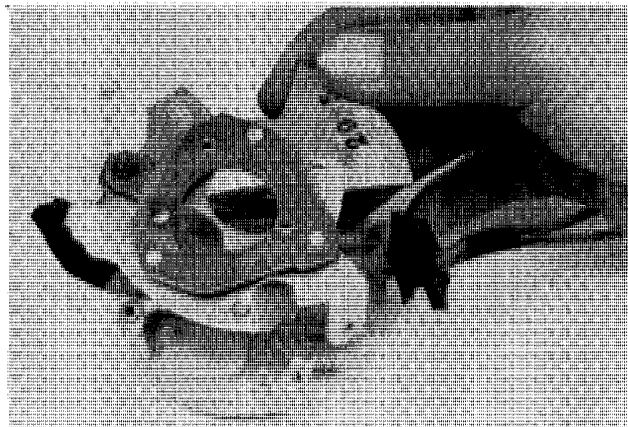

Remove the base plate clear of the electronic control system.

### STEP 52

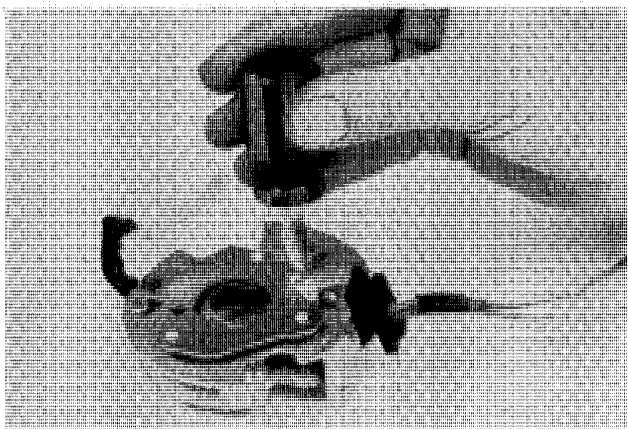

Install and tighten the three base plate retaining screws.

### STEP 53

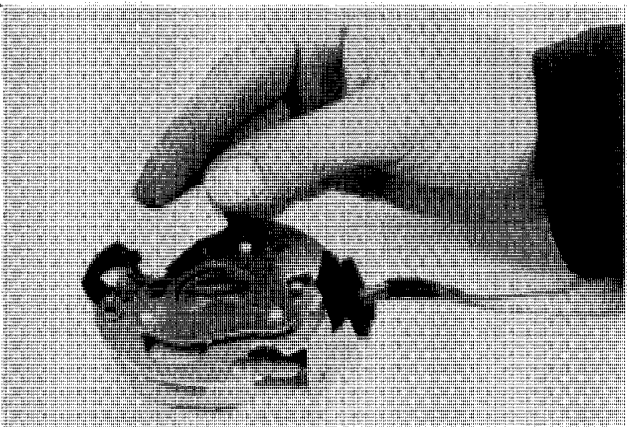

Put the sensor into the locating hole on the base plate.

# 3001

## ENGINE CONTROLS, FUEL LINES AND FUEL TANK

### TABLE OF CONTENTS

<b>Specifications</b> .....	3001-2	<b>Diesel Engine</b> .....	3001-6
<b>Gas Engine</b> .....	3001-2	Throttle Linkage Adjustment .....	3001-6
Throttle Linkage Adjustment .....	3001-2	Illustration of Diesel Engine Controls ..	3001-7
Illustration of Gas Engine Controls ....	3001-3	Replacing the Fuel Filter .....	3001-8
Fuel Filter .....	3001-4	Illustration of Fuel Lines and Fuel Tank/Diesel Engine .....	3001-9
Fuel Tank .....	3001-4	Removing the Air From the Fuel System .....	3001-10
Illustration of Fuel Line and Fuel Tank/Gas Engine .....	3001-5		

# **Section 3002**

**CARBURETOR, FUEL PUMP AND GOVERNOR  
TM20 Gasoline Engine**

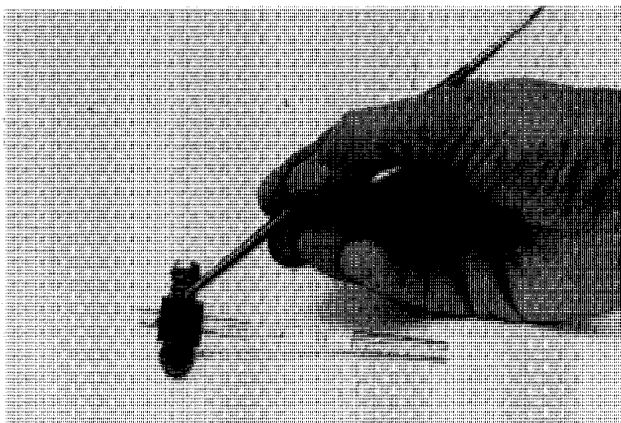
**STEP 34**

Drive out the roll pin and remove the shaft from the throttle stop.

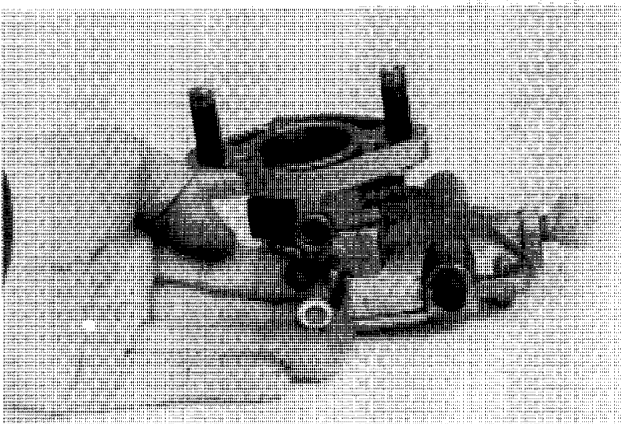
**STEP 35**

Remove the washer and seal.

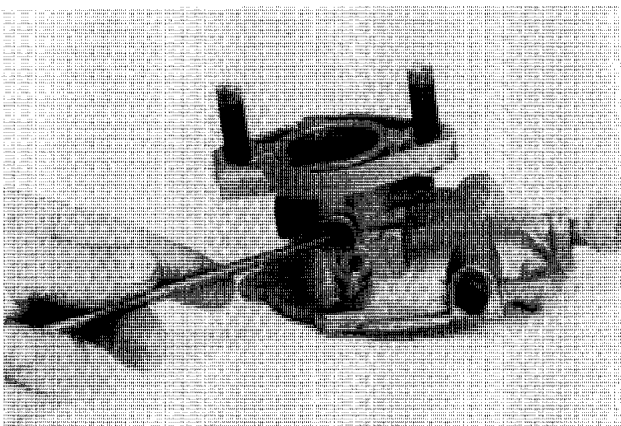
**STEP 36**

Inspect the throttle plate shaft bushings for damage or wear. Replace with new parts if necessary.

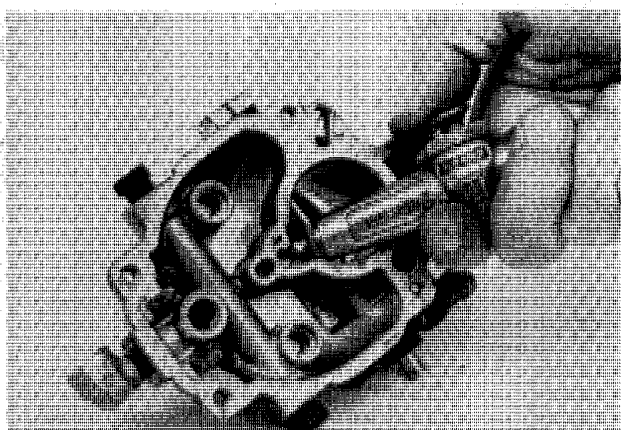
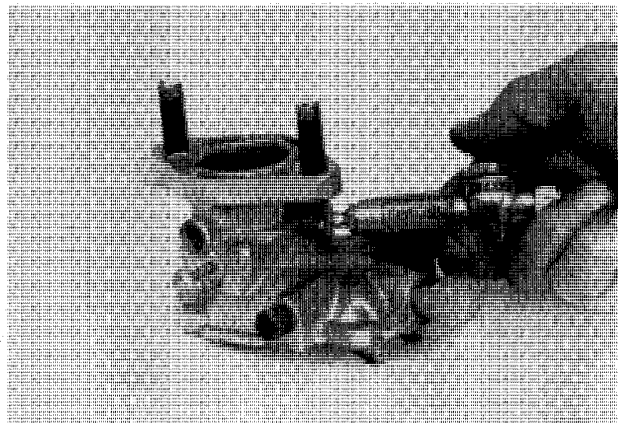
**STEP 37**

Use compressed air to make sure that all the ports in the carburetor top are free from dirt.

# Assembly

## STEP 82

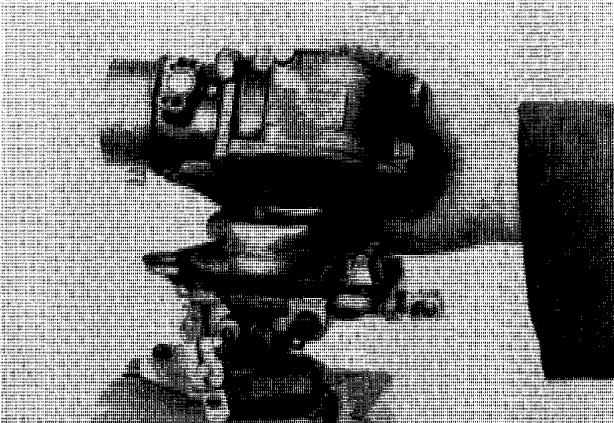

Install the float chamber body.

## STEP 83

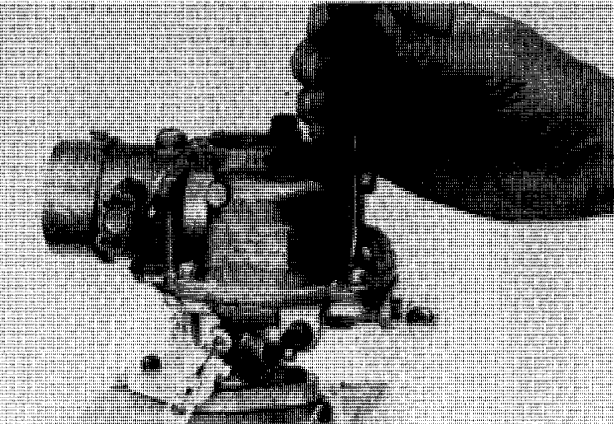

Install and tighten the four screws and spring washers which hold the float chamber body to the carburetor top.

## STEP 84

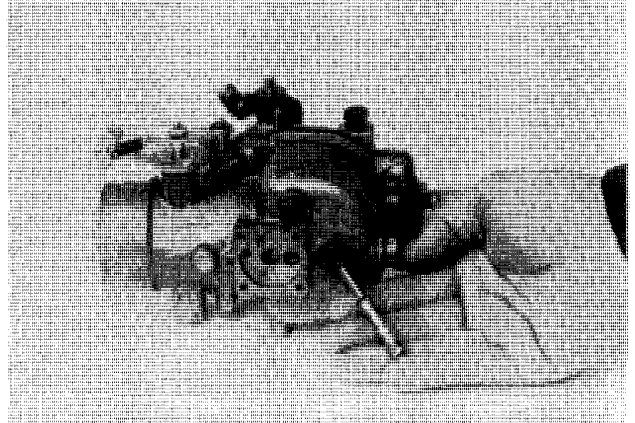

Fit a new seal washer and install and tighten the main jet.

## STEP 85

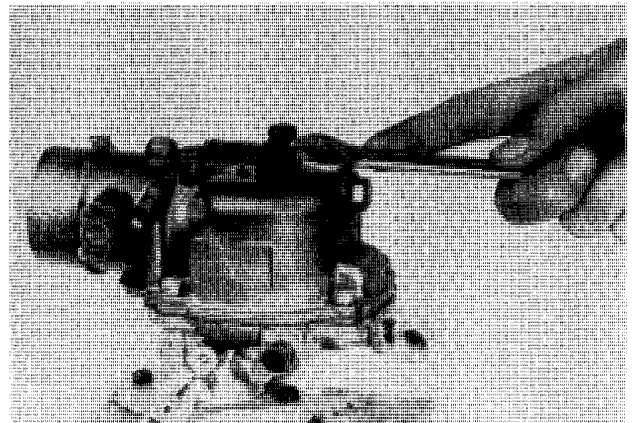

Fit a new sealing washer. Install and tighten the main jet access plug.

## Control Shaft Disassembly

### STEP 130

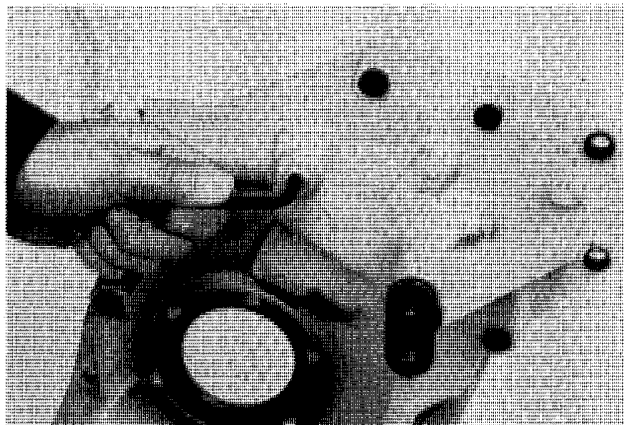

Remove the Allan screw from the timing cover.

### STEP 133

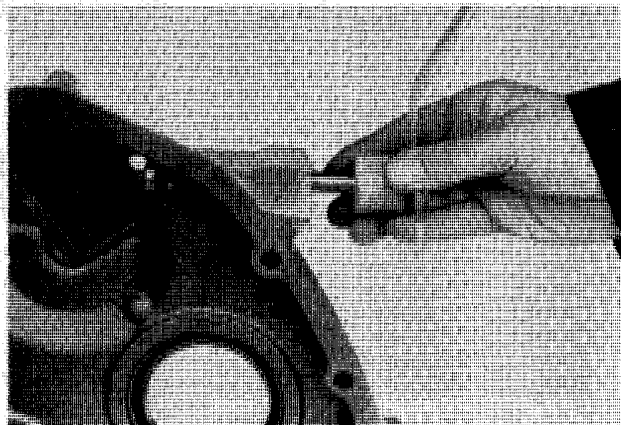

Remove the governor control shaft.

### STEP 131

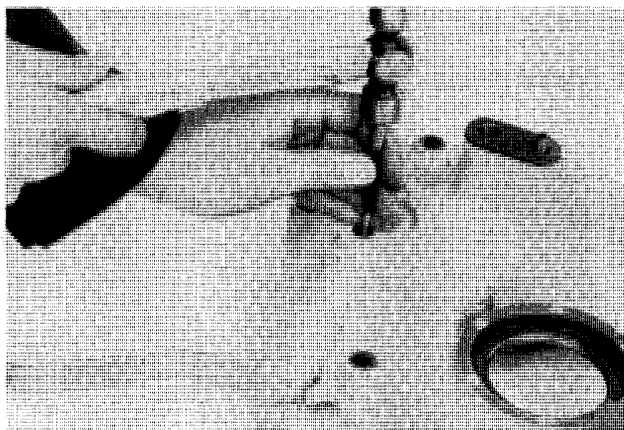

Use a pin punch and drive out the roll pin.

### STEP 134

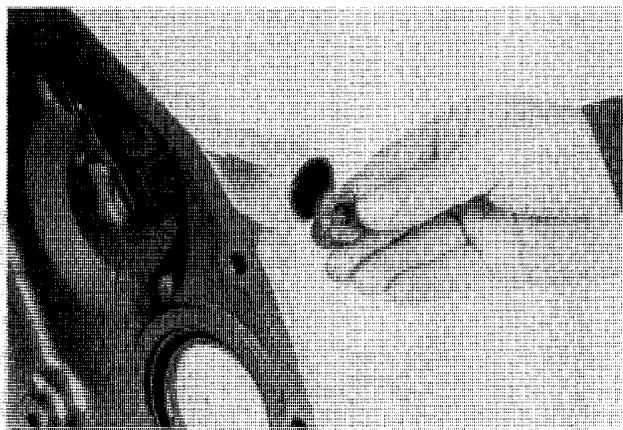

Remove the felt seal.

### STEP 132

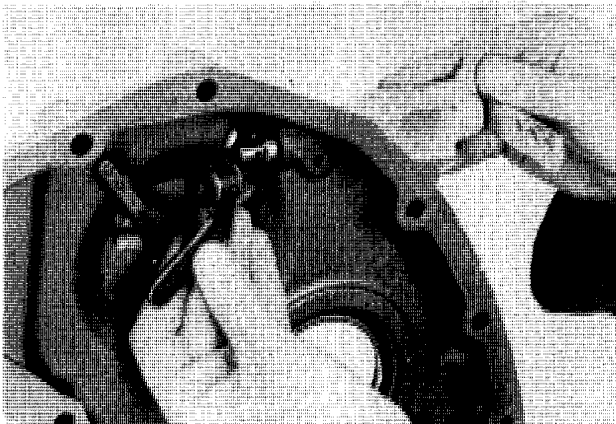

Remove the governor arm.

### STEP 135

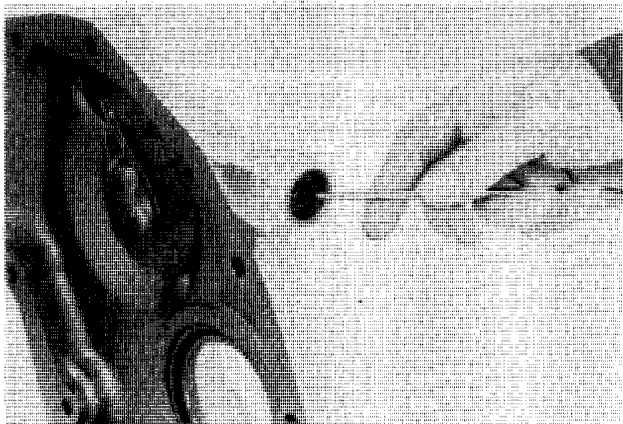

Remove the oil seal.

## SPECIAL TORQUES

Injection Pump Gear Bolts ..... 20 to 25 lb ft

27 to 34 Nm

## STANDARD TORQUES

### STANDARD TORQUE DATA FOR NUTS AND BOLTS

Where no special torque data is specified, the following torque figures can be applied. Threads must be lubricated with engine oil or chassis grease. Apply the minimum figure to bolts that have previously been used.

Thread Size	PHOSPHATE COATED FASTENERS							
	Class 8.8 Min		Class 8.8 Max		Class 9.8 Min		Class 9.8 Max	
	Nm	lb ft	Nm	lb ft	Nm	lb ft	Nm	lb ft
M6	8	6	11	8	8	6	11	8
M8	20	15	24	18	20	15	24	18
M10	34	25	40	30	34	25	40	30
M12	75	55	81	60	75	55	81	60
M14	122	90	135	100	122	90	135	100
M16	190	140	203	150	190	140	203	150

### PROPERTY CLASS MARKINGS

#### BOLTS AND SCREWS

The property class markings for metric bolts and screws are given in the table on the right. The marking is on the top of the bolt or screw head or may be indented on the side of the head.

PROPERTY CLASS	IDENTIFICATION SYMBOL	
	Bolts, Screws and Studs	Studs smaller than M12
8.8	8.8	○
9.8	9.8	+
10.9	10.9	□
12.9	12.9	△

## SPECIAL TOOLS

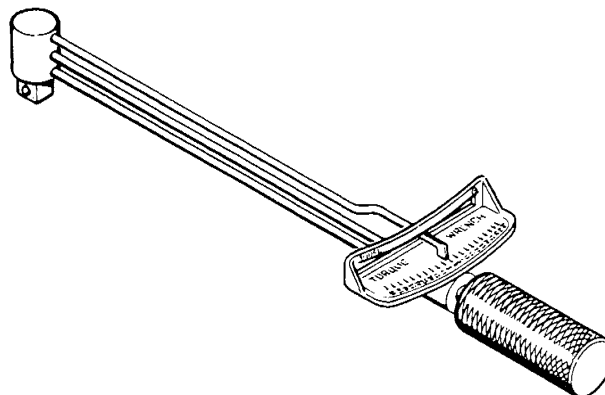

1. TORQUE WRENCH

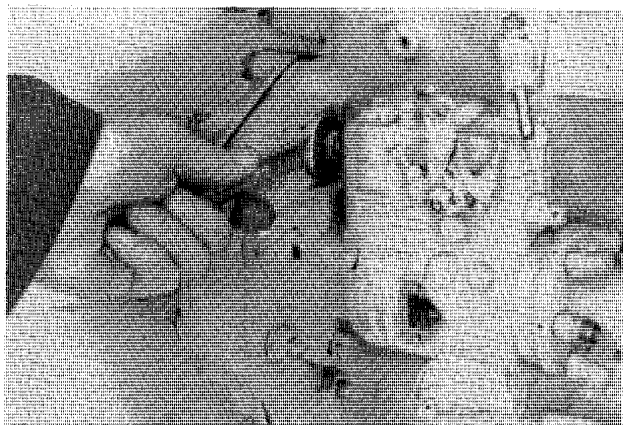
**STEP 47**

Install and tighten the mounting flange nuts and bolts.

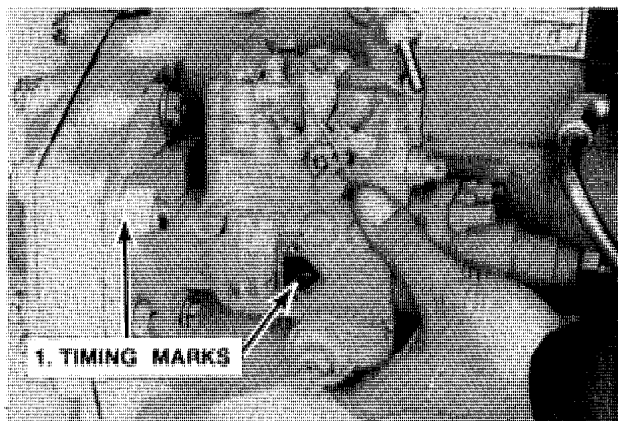
**STEP 48**

Turn the injection pump to align the timing marks on the injection pump and mounting flange. Make sure the timing mark on the injection pump is still aligned.

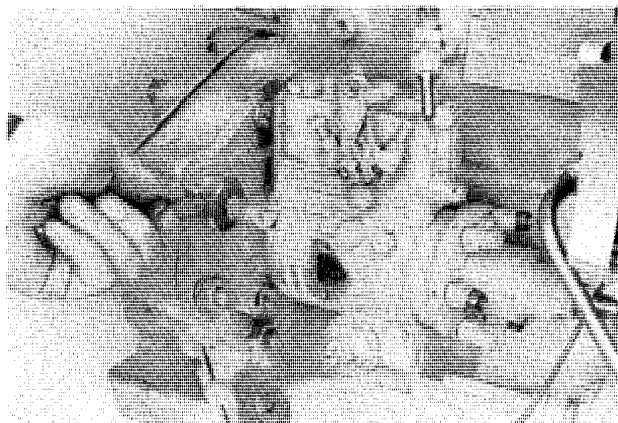
**STEP 49**

Tighten the bolts which retain the injection pump to the mounting flange.

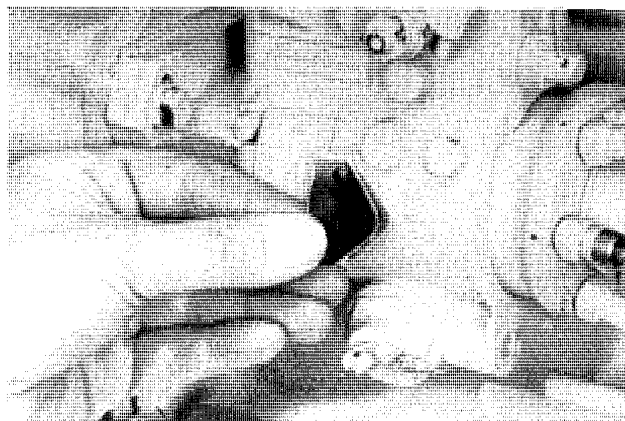
**STEP 50**

Install a new timing cover gasket.

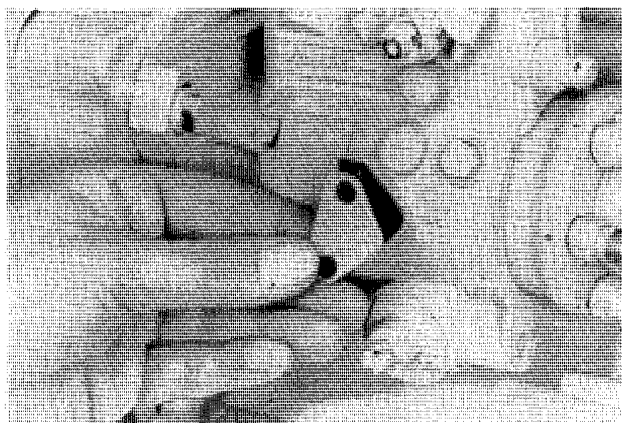
**STEP 51**

Install the cover.

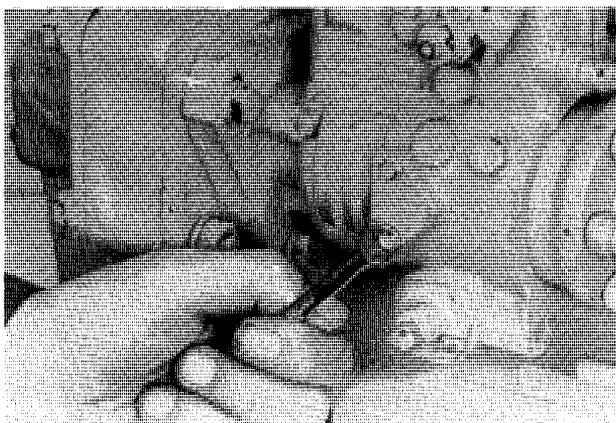
**STEP 52**

Install and tighten the retaining screws.

## SPECIAL TORQUES

Glow Plugs .....	23 to 28 lb ft	31 to 38 Nm
Injector Nozzle To Holder .....	50 to 55 lb ft	68 to 75 Nm
Injector To Cylinder Head .....	50 to 55 lb ft	68 to 75 Nm

## STANDARD TORQUES

### STANDARD TORQUE DATA FOR NUTS AND BOLTS

Where no special torque data is specified, the following torque figures can be applied. Threads must be lubricated with engine oil or chassis grease. Apply the minimum figure to bolts that have previously been used.

Thread Size	PHOSPHATE COATED FASTENERS							
	Class 8.8 Min		Class 8.8 Max		Class 9.8 Min		Class 9.8 Max	
	Nm	lb ft	Nm	lb ft	Nm	lb ft	Nm	lb ft
M6	8	6	11	8	8	6	11	8
M8	20	15	24	18	20	15	24	18
M10	34	25	40	30	34	25	40	30
M12	75	55	81	60	75	55	81	60
M14	122	90	135	100	122	90	135	100
M16	190	140	203	150	190	140	203	150

### PROPERTY CLASS MARKINGS

#### BOLTS AND SCREWS

The property class markings for metric bolts and screws are given in the table on the right. The marking is on the top of the bolt or screw head or may be indented on the side of the head.

PROPERTY CLASS	IDENTIFICATION SYMBOL	
	Bolts, Screws and Studs	Studs smaller than M12
8.8	8.8	○
9.8	9.8	+
10.9	10.9	□
12.9	12.9	△

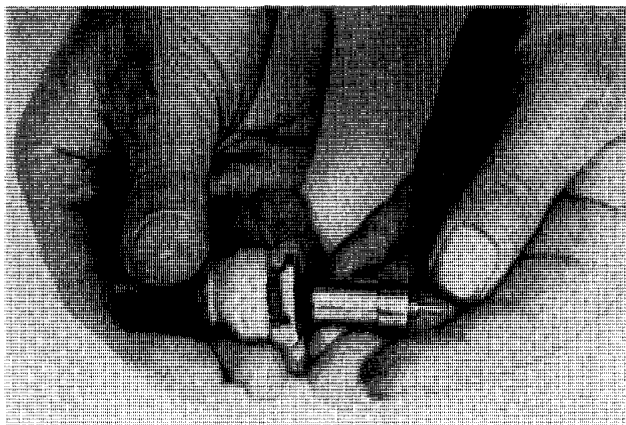
**STEP 24**

Remove the injector tip and valve.

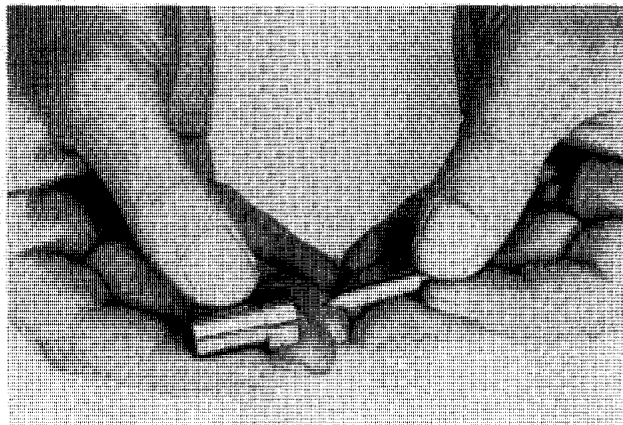
**STEP 25**

Remove the injector valve.

## Cleaning And Inspection

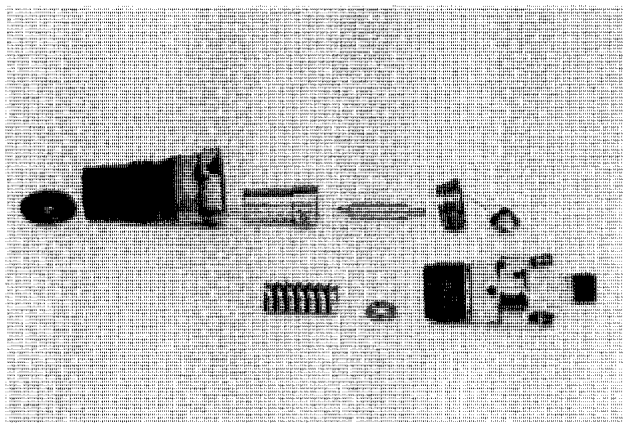
**STEP 26**

Put all the injector parts in a solvent to remove carbon deposits.

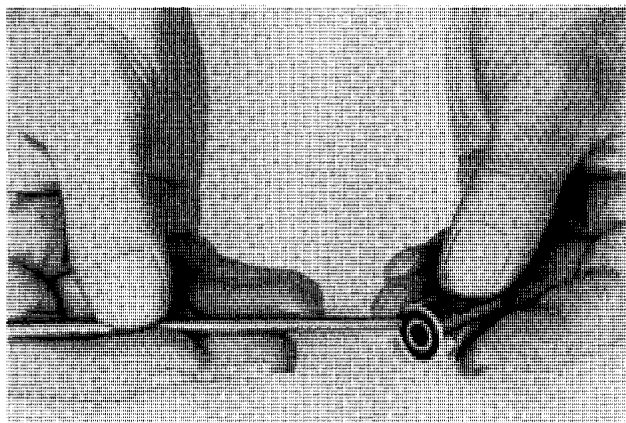
**STEP 27**

Use compressed air to remove carbon deposits from the small holes in the injector body.

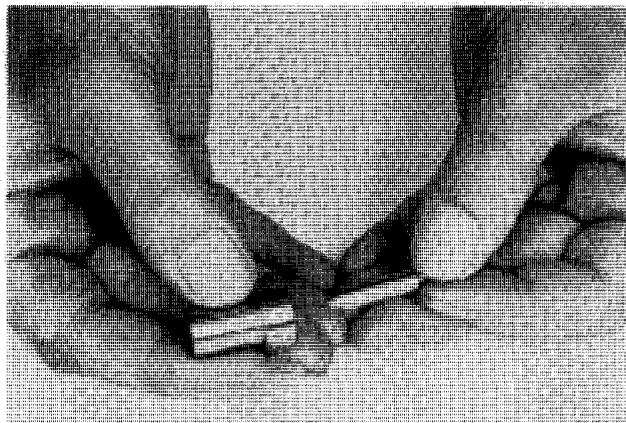
**STEP 28**

Check that the injector valve moves freely in the injector tip. Use a magnifying glass CAS 66-0135 to inspect the valve. Look for pitting and that the valve is straight.

# 4000

## REMOVAL AND INSTALLATION OF ELECTRICAL COMPONENTS

### TABLE OF CONTENTS

<b>Starter</b> .....	4000-2
<b>Alternator</b> .....	4000-2
<b>Drive Belt</b> .....	4000-4

**STEP 25**

Connect the positive voltmeter lead to the terminal in the connector. Connect the negative voltmeter lead to a good ground connection on the engine.

1. If the voltmeter indicates voltage at the terminal, do the Alternator and Voltage Regulator Test.
2. If the voltmeter does not indicate voltage at the terminal, do the next step.

**STEP 26**

Find the resistor that is mounted on the front of the engine.

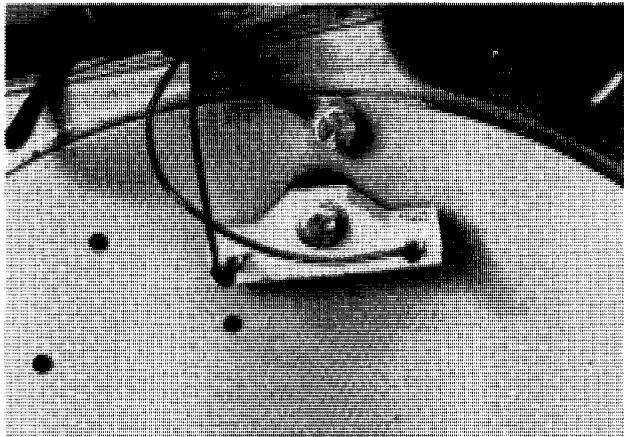

876527

**STEP 27**

Connect the negative voltmeter lead to a good ground connection on the machine. Use the positive voltmeter lead to check for voltage at both of the terminals of the resistor.

1. If the voltmeter indicates voltage at both of the terminals, repair or replace the wire between the resistor and the alternator.
2. If the voltmeter indicates voltage at only one of the terminals, replace the resistor.
3. If the voltmeter does not indicate voltage at either terminal, use the voltmeter to check the circuit between the resistor and the key switch. See the electrical schematic in Section 4003.

**STEP 28**

If the alternator still does not operate correctly, do the following test.

**Alternator and Voltage Regulator Test**

This test must be done using a tester for charging systems. The following test is written for the use of an OTC Charging System Analyzer (CAS-10344). Other test equipment can be used. Connect the test equipment according to the instructions of the manufacturer.

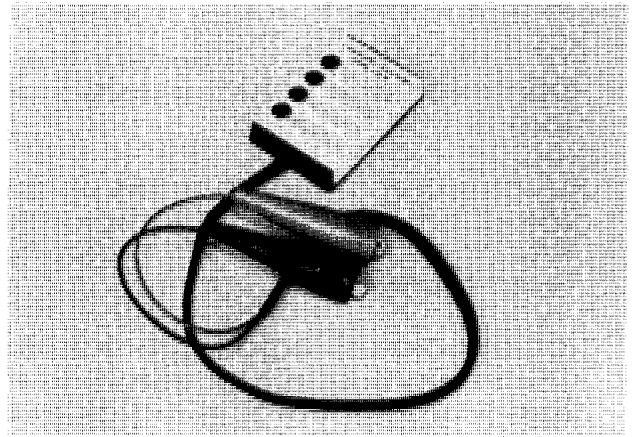

519617

**STEP 29**

Do the Checking Voltage at the Alternator Terminals procedure on page 4002-6.

**STEP 30**

Pull the boot away from the B+ terminal of the alternator.

**STEP 31**

Connect the red lead of the tester to the B+ terminal of the alternator. Connect the black lead of the tester to a good ground connection on the machine.

1. If lamp 2 of the tester is illuminated, the test connection and the battery are good. Do the next step.
2. If lamps 2 and 4 of the tester are illuminated, the level of charge in the battery is too low to complete the test. See Section 4005 and charge the battery.
3. If none of the lamps in the tester illuminates, check the connections for the tester.

**STEP 32**

Have another person start the engine while you look at the tester.

# 4003

## ELECTRICAL SCHEMATIC

### TABLE OF CONTENTS

<b>Electrical Schematic</b> .....	4003-2
-----------------------------------	--------

## TABLE OF CONTENTS

SPECIFICATIONS .....	3
STANDARD TORQUES .....	4
SPECIAL TOOLS .....	5
REMOVING THE STARTER MOTOR .....	6
TESTING THE STARTER MOTOR	
No Load Test .....	7
Magnetic Switch Test .....	10
SERVICING THE STARTER MOTOR	
Disassembly .....	12
Inspection and Testing .....	16
Assembly .....	25
INSTALLING THE STARTER MOTOR .....	31



*THIS SAFETY ALERT SYMBOL INDICATES IMPORTANT SAFETY MESSAGES IN THIS MANUAL. WHEN YOU SEE THIS SYMBOL, CAREFULLY READ THE MESSAGE THAT FOLLOWS AND BE ALERT TO THE POSSIBILITY OF PERSONAL INJURY OR DEATH.*

## SERVICING THE STARTER MOTOR Disassembly

### STEP 24

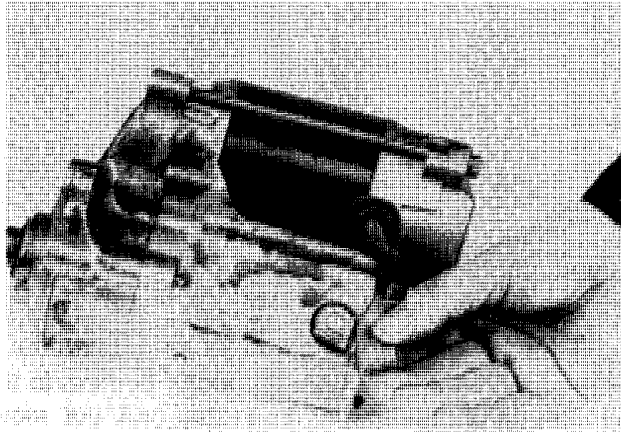

Pull the rubber boot clear of the motor terminal.

### STEP 25

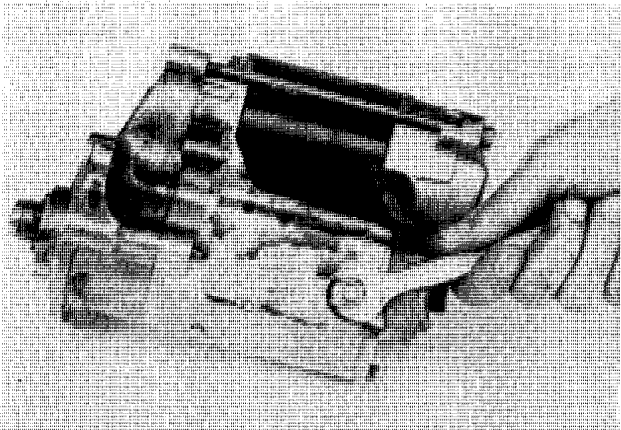

Remove the nut and lockwasher then pull the lead from the terminal.

### STEP 26

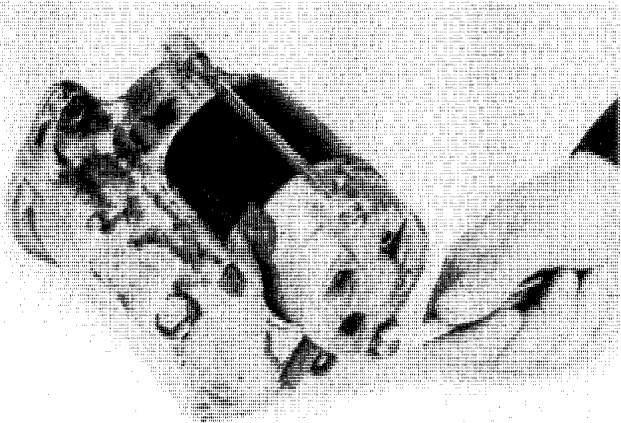

Remove the two long retaining bolts from the end of the motor.

### STEP 27

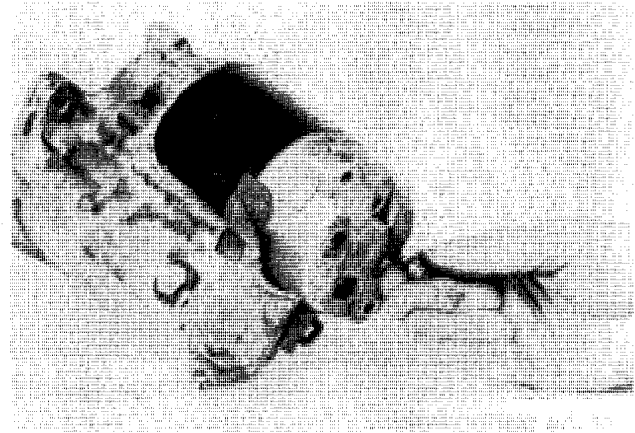

Remove the two screws, washers and sealing rings from the motor cover.

### STEP 28

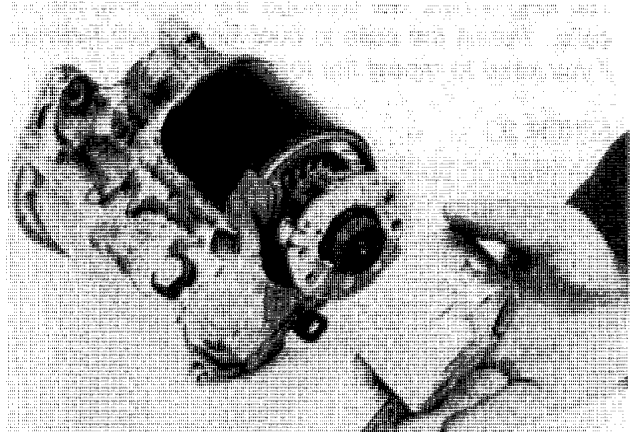

Remove the motor cover.

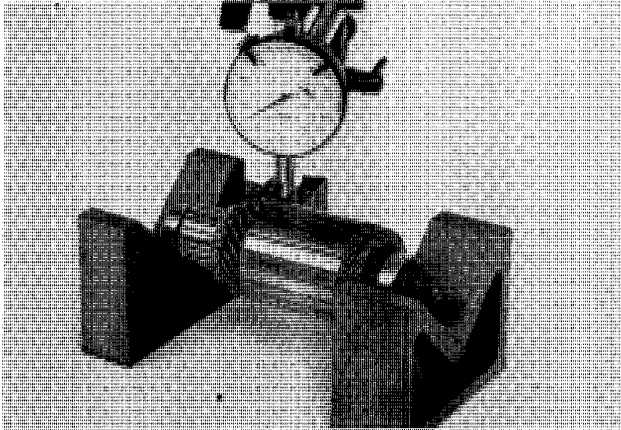
**STEP 77**

Put the armature on vee-blocks as shown and check the run-out of the armature with a dial indicator. The run-out must not be more than 0.002 inch (0.05 mm).

**NOTE:** If the run-out is more than 0.002 inch (0.05 mm) install a new armature. DO NOT try to straighten or repair.

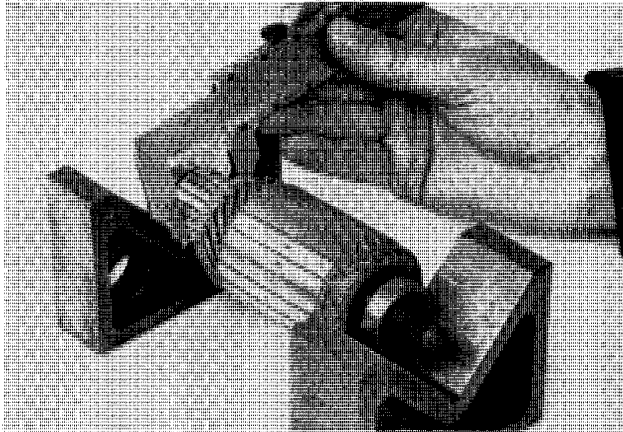
**STEP 78**

Check the commutator for wear marks. If necessary, put the armature in a lathe and remove enough material to make the commutator smooth. Measure the diameter of the commutator at several different positions. If the diameter is less than 1.14 inch (29 mm), install a new armature. The difference between the diameters must not be more than 0.016 inch (0.4 mm).

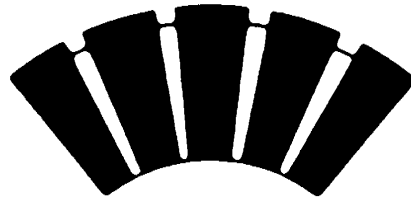
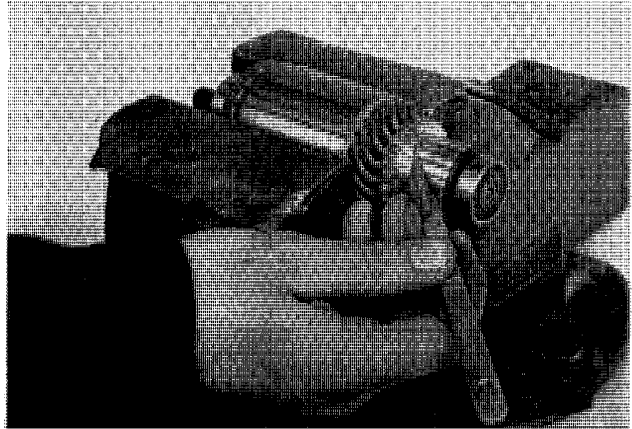
**STEP 79**

Check the mica insulation between the commutator segments. It must be 0.015 to 0.031 inch (0.5 to 0.8 mm) below the surface of the commutator segments. If necessary, use a sharp knife to make the mica depth correct then remove any rough edges from the commutator segments with sandpaper.

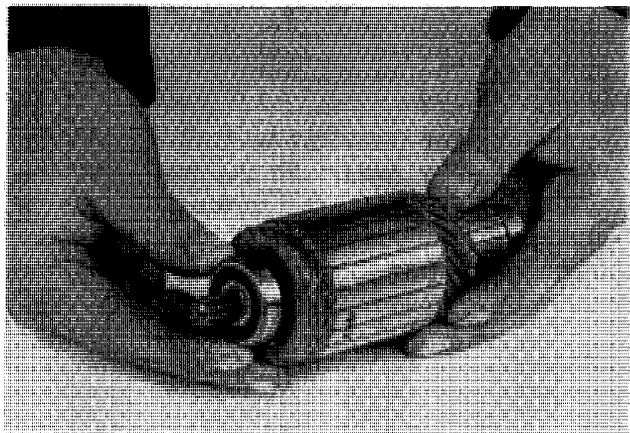
**STEP 80**

Check the armature bearings for wear and rough movement. Replace the bearings if necessary.



## Inspection

### STEP 31

Clean the starter drive components with a clean dry cloth and inspect the gears, shaft and bearings referring to General Inspection Instructions.

### STEP 32

Clean the electrical components using clean mineral spirits and dry with a clean cloth.

### STEP 33

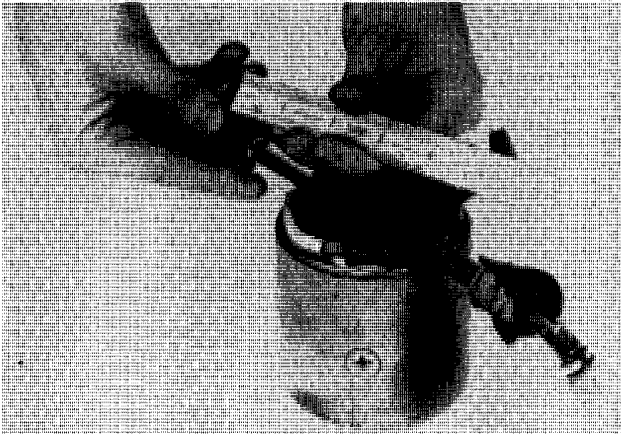

Measure the brushes, connected to the field frame. If any brush is less than 0.4375 inch (11 mm) a new field frame assembly must be installed.

### STEP 34

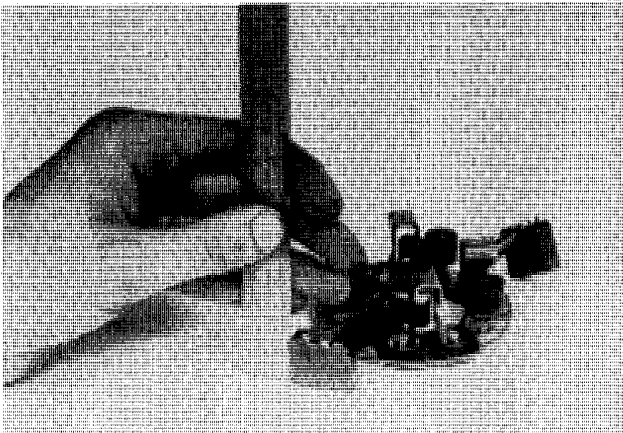

Measure the brushes connected to the brush holder. If any brush connected to the brush holder is less than 0.4375 inch (11 mm) a new brush holder assembly must be installed.

### STEP 35

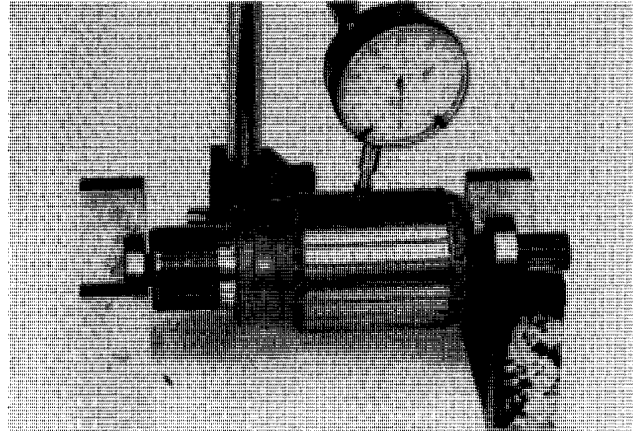

Put the armature between vee blocks and check the armature run out with a dial indicator as shown. The run out must not be more than 0.002 inch (0.05 mm). If the run out is more than 0.002 inch (0.05 mm) it is possible to install the armature in a lathe and remove enough material to make the run out less than 0.002 inch (0.05 mm).

**NOTE:** Do not try to straighten or repair a distorted armature shaft. A new armature must be installed.

### STEP 36

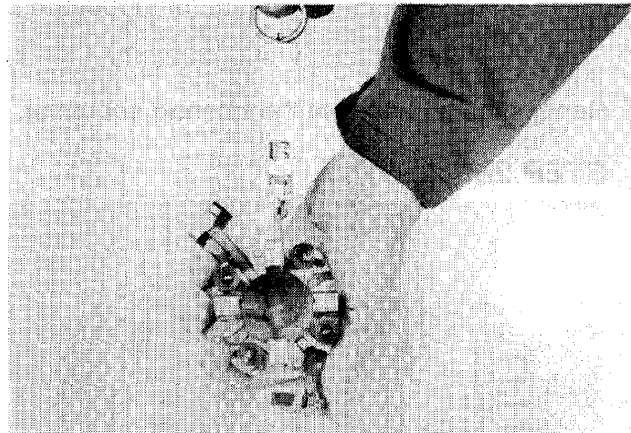

Use a spring scale to measure the brush spring tension. The spring tension must be 4 to 9 lbs (1.8 to 4.1 kg). If the spring tension is less than 4 lbs (1.8 kg) new springs must be installed.

## TABLE OF CONTENTS

SPECIFICATIONS .....	3
SPECIAL TORQUES .....	3
STANDARD TORQUES .....	3
SPECIAL TOOLS .....	4
ALTERNATOR	
Removal .....	5
Disassembly .....	6
Inspection .....	10
Assembly .....	15
Installation .....	19

**STEP 40**

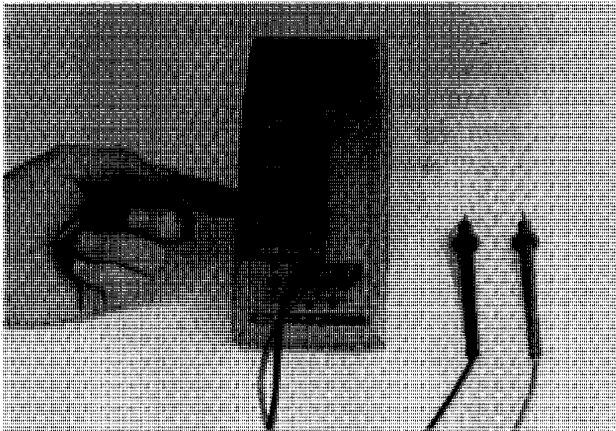

**STEP 41**

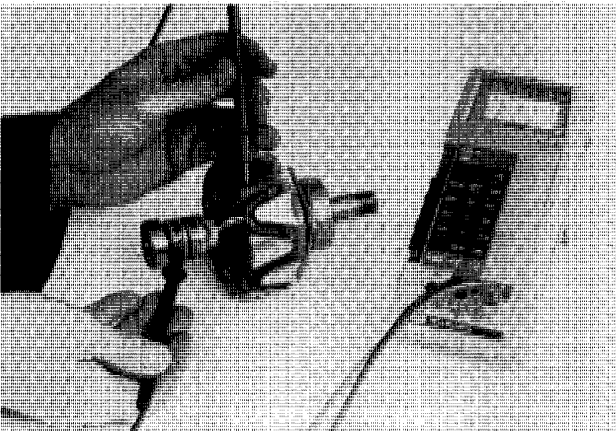
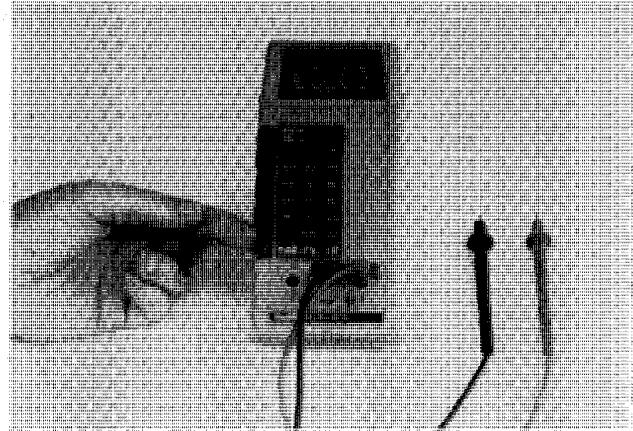

Set the multimeter to the 20M  $\Omega$  position and put one probe on a slip ring and the other probe on the rotor windings as shown and test for short circuit. If a reading is given there is a short circuit and the rotor must be replaced.

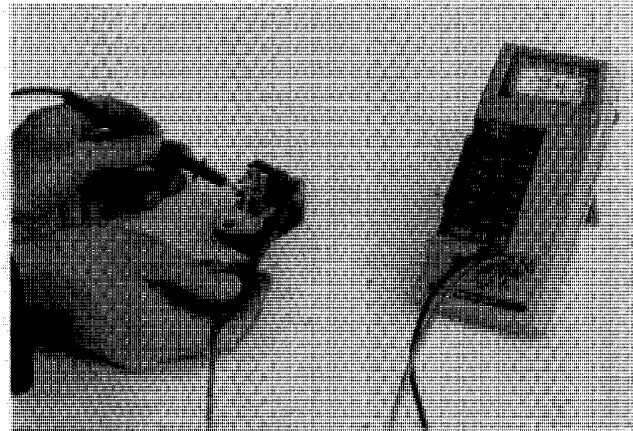

Set the multimeter to 200- $\Omega$  and put one probe on the brush and the other probe on the terminal and test for continuity. If no reading is given replace the brush. Repeat test on the other brush.

## TABLE OF CONTENTS

SPECIFICATIONS .....	3
SPECIAL TORQUES .....	3
STANDARD TORQUES .....	3
SPECIAL TOOLS .....	4
ALTERNATOR	
Removal .....	5
Disassembly .....	6
Inspection .....	10
Assembly .....	15
Installation .....	19

**STEP 40**

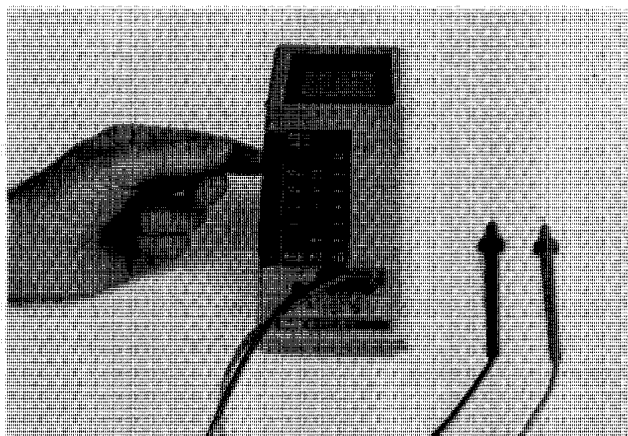

**STEP 41**

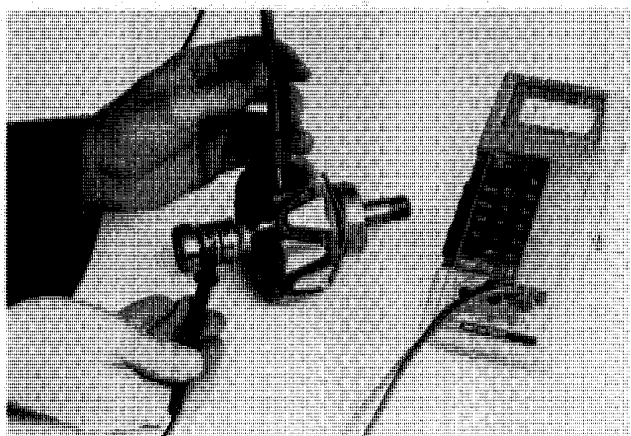
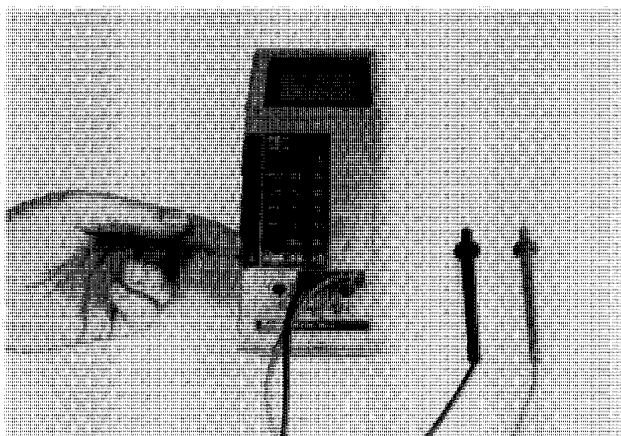

Set the multimeter to the 20M  $\Omega$  position and put one probe on a slip ring and the other probe on the rotor windings as shown and test for short circuit. If a reading is given there is a short circuit and the rotor must be replaced.



Set the multimeter to 200  $\Omega$  and put one probe on the brush and the other probe on the terminal and test for continuity. If no reading is given replace the brush. Repeat test on the other brush.

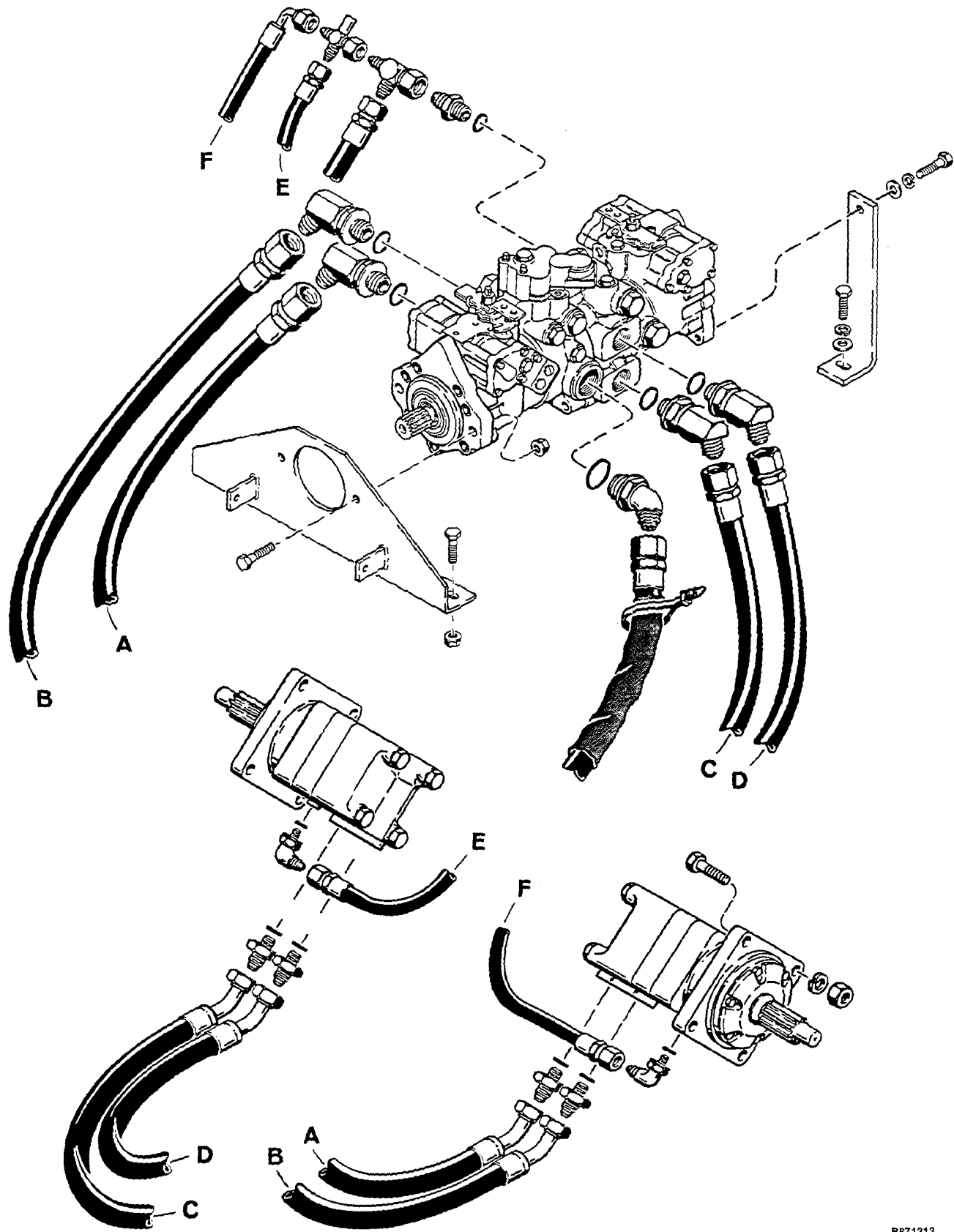

Installation of Pumps and Motors

## CHAIN COMPARTMENTS

The oil in each chain compartment must be changed after every 500 hours of operation or yearly.

### STEP 1

Raise the wheels off the floor and use blocks to hold the machine in place.

### STEP 2

Loosen and remove the wheel nuts and wheels.

### STEP 3

Loosen and remove the nuts, lock washers, and flat washers that hold the cover for the motor sprocket.

### STEP 4

Before removing the cover, loosen the plug in the cover. The plug will be removed during installation to help install the cover.

### STEP 5

Remove the cover.

### STEP 6

If the gasket is damaged, remove the gasket from the frame (or cover).

### STEP 7

Have available a drain pan that will hold 1-1/2 U.S. gallon (6 litres).

### STEP 8

Loosen and remove the drain plug and drain the oil.

### STEP 9

Flush the chain compartment with clean diesel fuel.

### STEP 10

Install and tighten the drain plug.

### STEP 11

Fill the chain compartment with 4 U.S. quarts of 10W-30 engine oil.

### STEP 12

If necessary, install a new gasket for the cover.

### STEP 13

Remove the plug from the cover.

### STEP 14

Align the bearing with the shaft and push the cover onto the studs.

### STEP 15

Install the flat washers, lock washer, and nuts and tighten the nuts.

### STEP 16

Install and tighten the plug.

### STEP 17

Install the wheels and wheel nuts.

### STEP 18

Tighten the wheel nuts to 80 to 90 pound-feet (108 to 122 Nm).

### STEP 19

Remove the blocks and lower the wheels to the floor.

## CHECKING CHAIN DEFLECTION

The deflection of the chains must be checked after the first 100 hours of operation, then after every 250 hours of operation.

See Section 6007 for instructions.

## INSPECTION

### STEP 11

Clean all parts in cleaning solvent.

### STEP 12

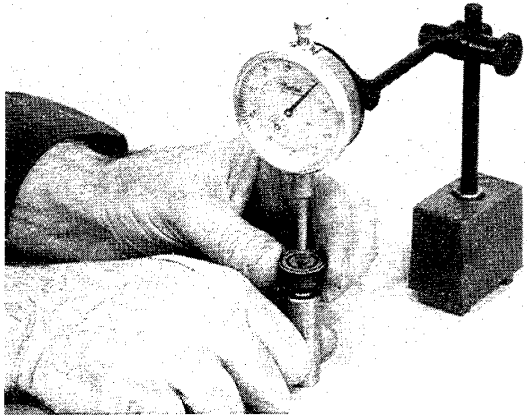

313202

Use compressed air to dry the piston and shoe joints. Then measure the free travel of the shoes. If all measurements are not equal to within .005 inch (0.127 mm), install a new cylinder block assembly.

### STEP 13

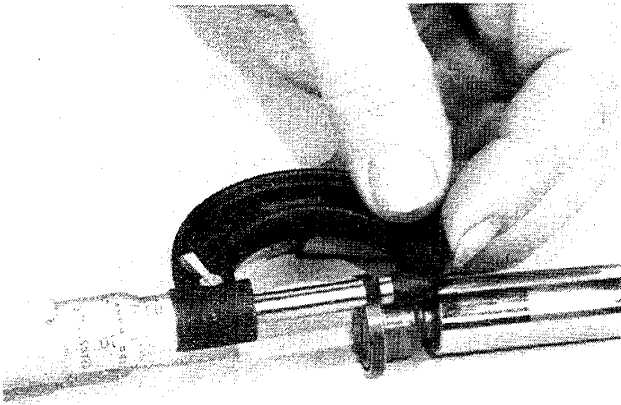

313327

Measure the thickness of each shoe. If the measurements are not equal within .001 inch (0.25 mm), install a new cylinder block assembly.

### STEP 14

Inspect the face of the cylinder block for wear, scoring, and grooves. If a groove connects two or more cylinders, install a new cylinder block assembly.

### STEP 15

Inspect the cylinders for scoring and grooves that will result in too much leakage between the pistons and cylinders.

### STEP 16

Lubricate the pistons and cylinders with clean oil. Check the fit of a piston in each cylinder. The piston must not be loose in the cylinder and must move freely.

### STEP 17

Inspect the bronze surface of the wear plate for wear, scoring and grooves. If a groove connects two or more slots, install a new wear plate.

### STEP 18

Inspect the support for wear, scoring and cracks.

### STEP 19

Inspect the support surface on the guide for wear and scoring. Also check the guide for cracks.

### STEP 20

Inspect the seat end of the poppet and the circuit relief valves for wear.

### STEP 21

Inspect the seats for the poppet and circuit relief valves in the housing for wear.

### STEP 22

Inspect the parts of the charging pump for wear, scoring and grooves.

### STEP 23

Inspect the needle bearing in the housing for wear and damage.

### STEP 24

Check the ball bearing for flat areas on the balls and inner and outer races.

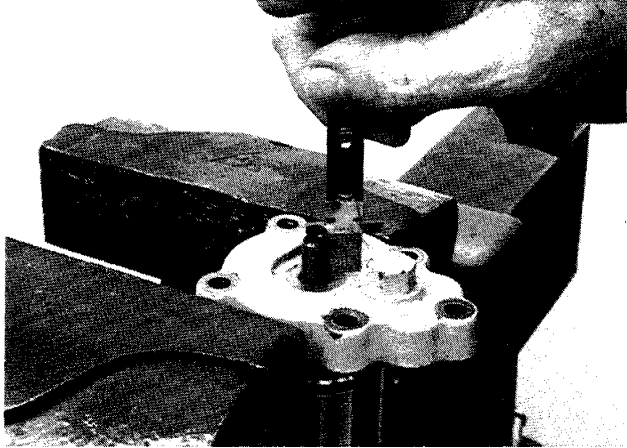
**STEP 75**

707510

Measure the distance from the top of the adjusting screw to the cover as shown. Make a record of the measurement for use during assembly.

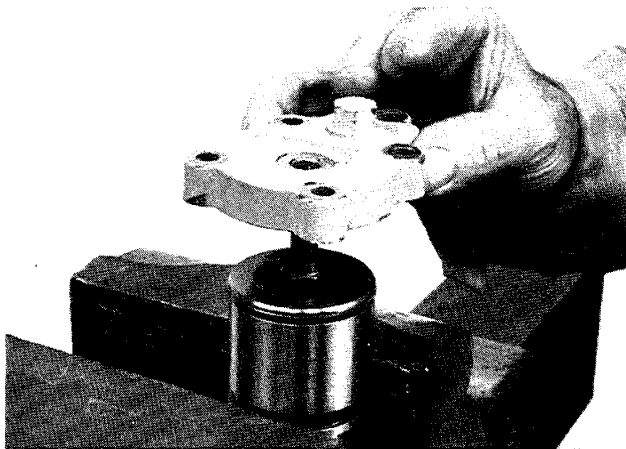
**STEP 76**

707512

Turn the cover off the adjusting screw.

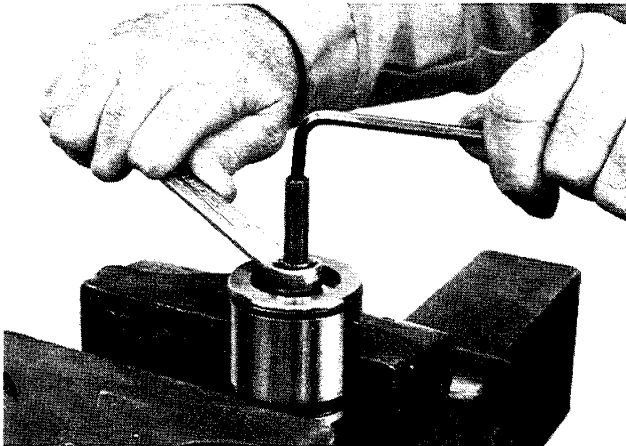
**STEP 77**

707514

Tighten the self-locking nut on the adjusting screw for removal of the snap ring.

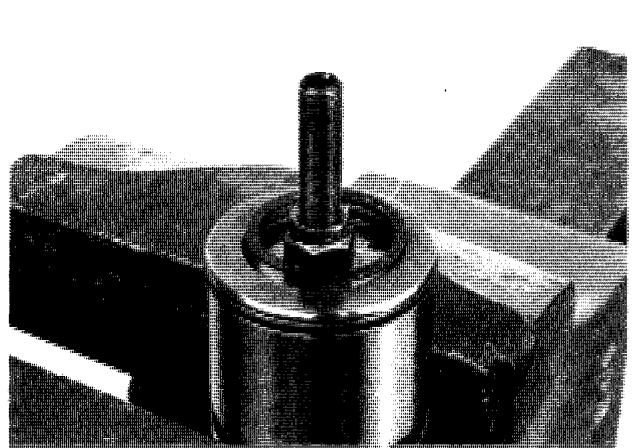
**STEP 78**

707516

Remove the snap ring. The snap ring can be difficult to remove.

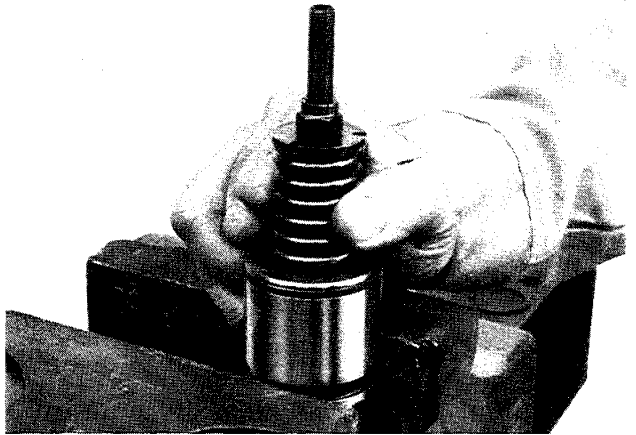
**STEP 79**

707518

Remove the spring assembly.

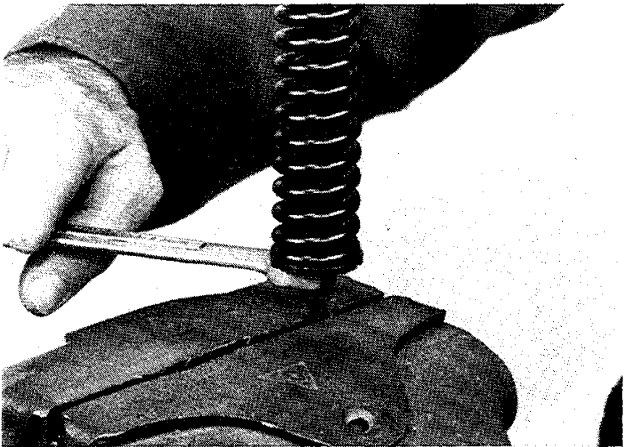
**STEP 80**

518832

To remove the spring, fasten an Allen wrench in the vise and loosen and remove the self-locking nut.

**STEP 136**

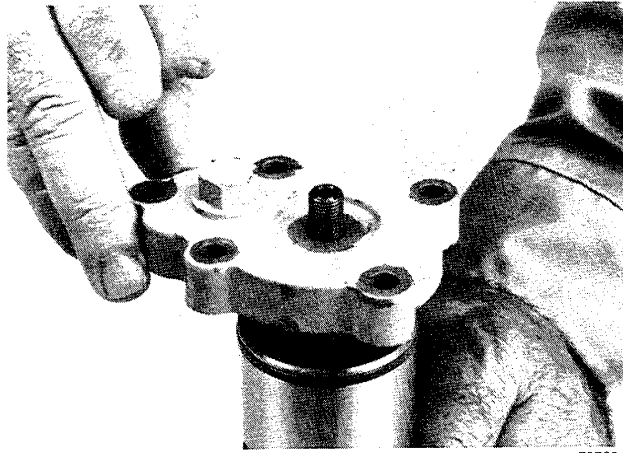

707604

Turn the cover onto the adjusting screw equal to the measurement made during disassembly.

**STEP 137**

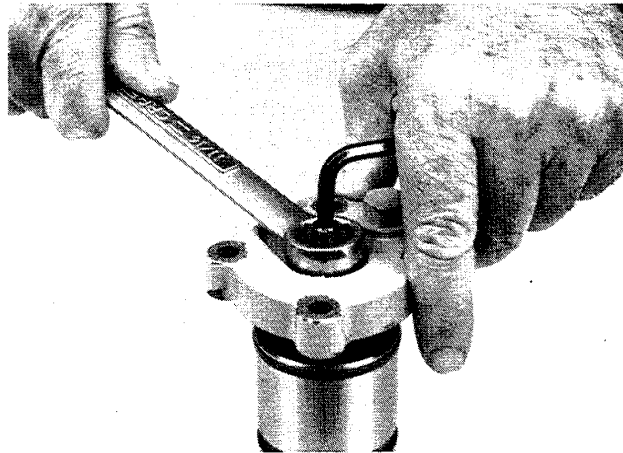

707608

Install the self-locking nut and prevent the adjusting screw and cover from turning and tighten the self-locking nut.

**STEP 138**

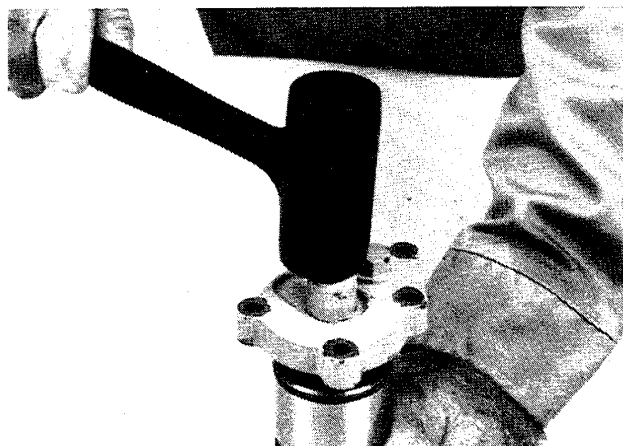

607610

Install the cap.

**STEP 139**

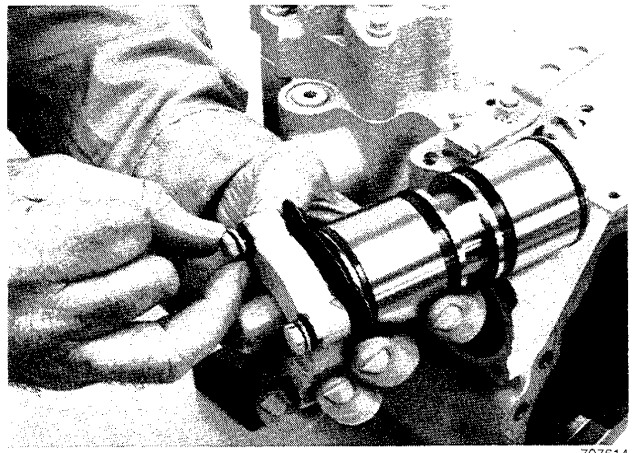

707614

Install a new gasket and two cap screws to hold the gasket.

**STEP 140**

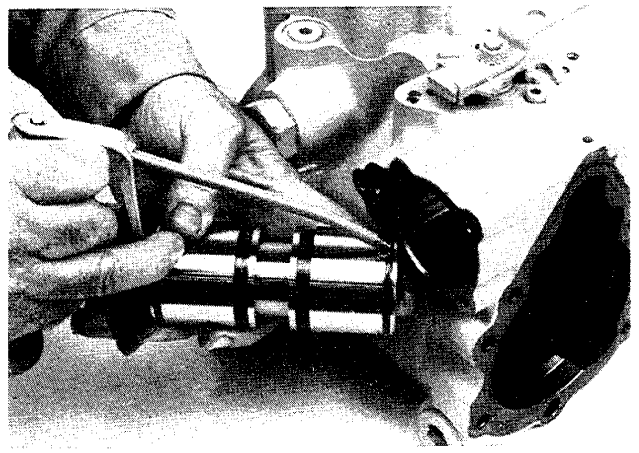

707616

Lubricate the servo piston and the bore with clean oil.

**STEP 141**



707706

Install the servo piston.

### Assembly of End Cover

#### STEP 190

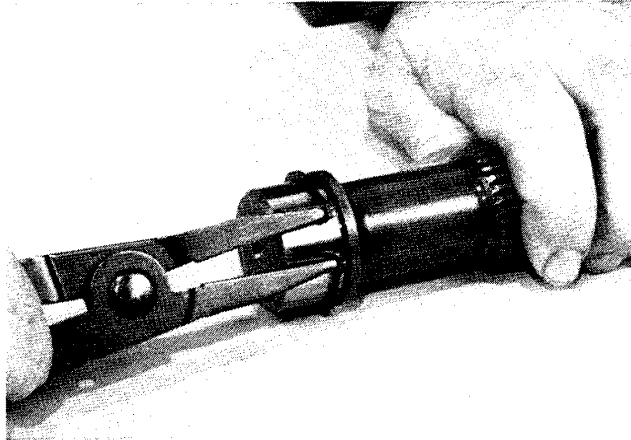

520522

Make sure that the snap ring is installed in the groove in the shaft.

#### STEP 191

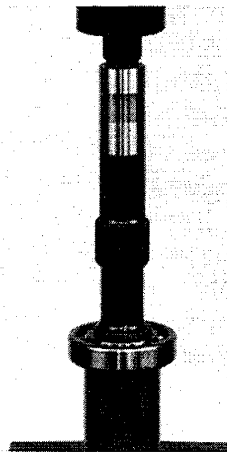

520602

Press the shaft into the ball bearing until the snap ring touches the inner race.

#### STEP 192

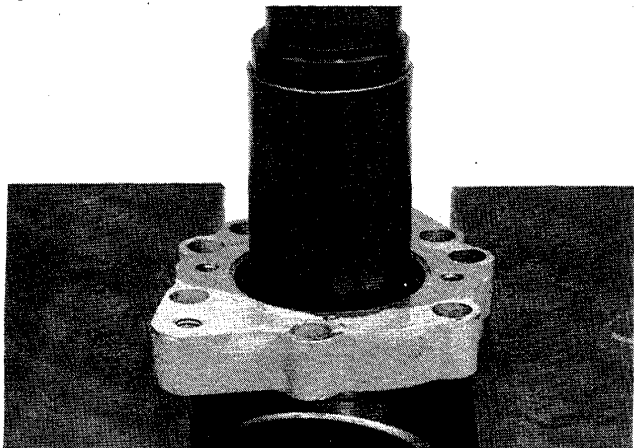

520606

Use an acceptable driver and press the ball bearing into the end cover.

#### STEP 193

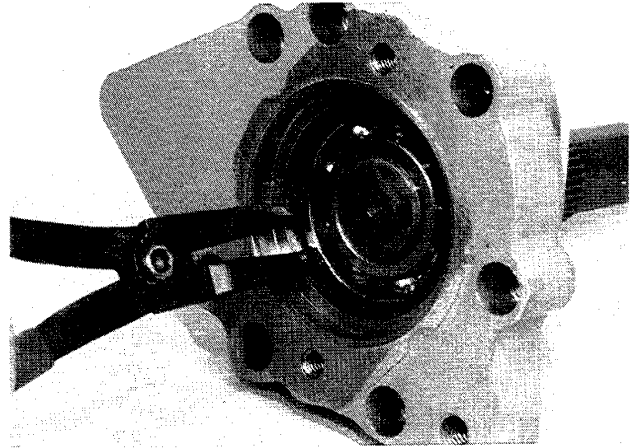

520514

Install the snap ring.

### Installation of Cylinder Block, Swash Plate and End Cover

#### STEP 194



519144

Put the pistons in the guide.

#### STEP 195

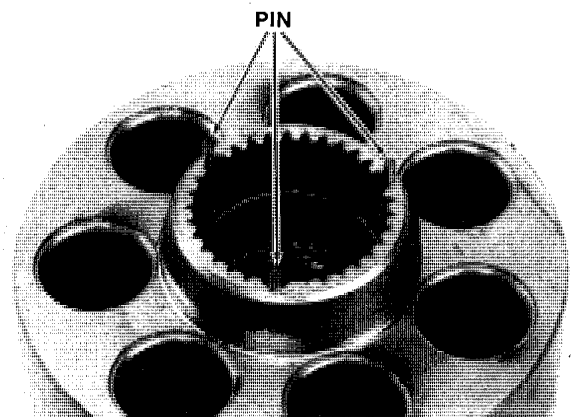

518616

Make sure that the pins are installed in the correct splines in the cylinder block.

**STEP 18**

Remove the spacer from the bore in the thrust plate.

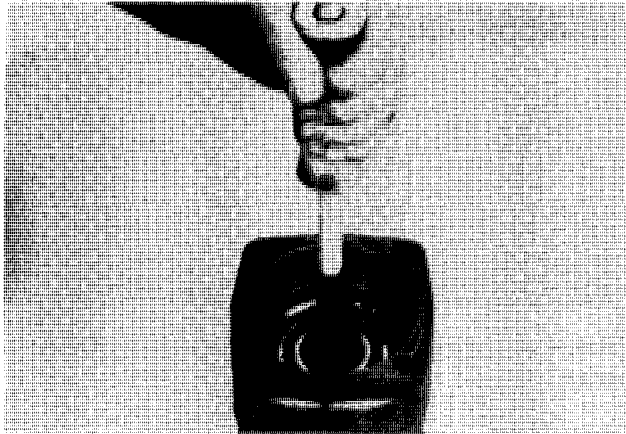
**STEP 19**

Use the blind hole puller shown on page 6005-2 and remove the thrust plate.

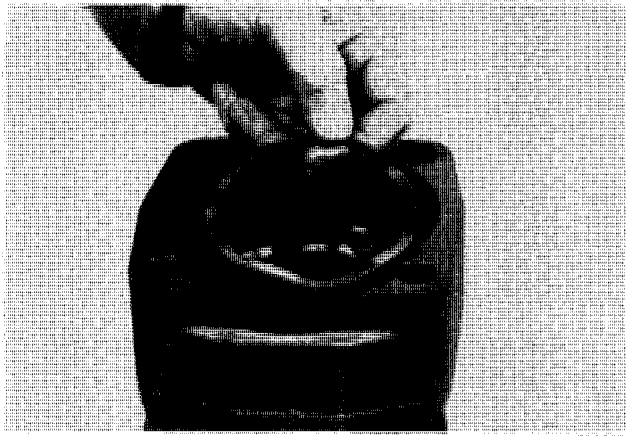
**STEP 20**

Remove the wave spring.

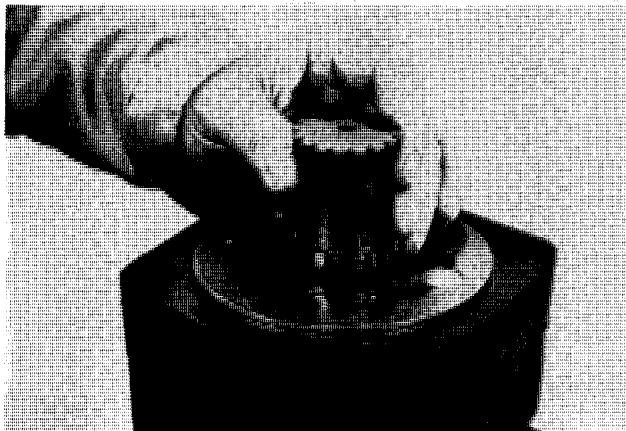
**STEP 21**

Remove the short shaft.

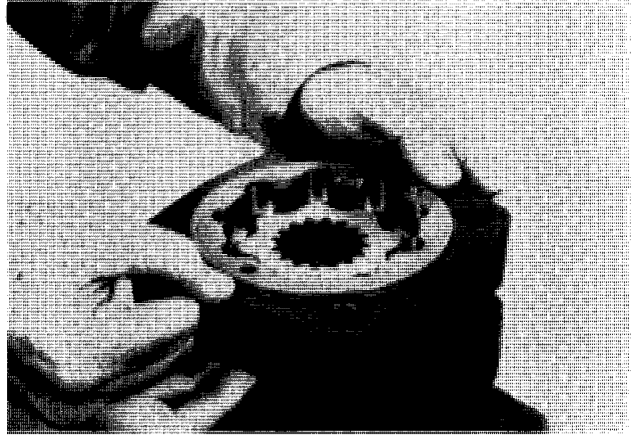
**STEP 22**

Remove the stator.

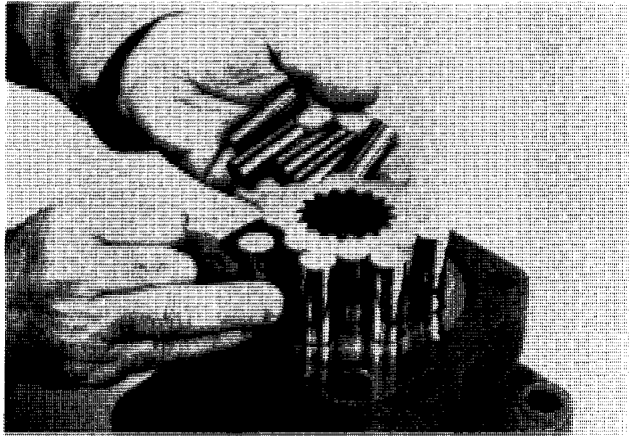
**STEP 23**

Remove the rollers.

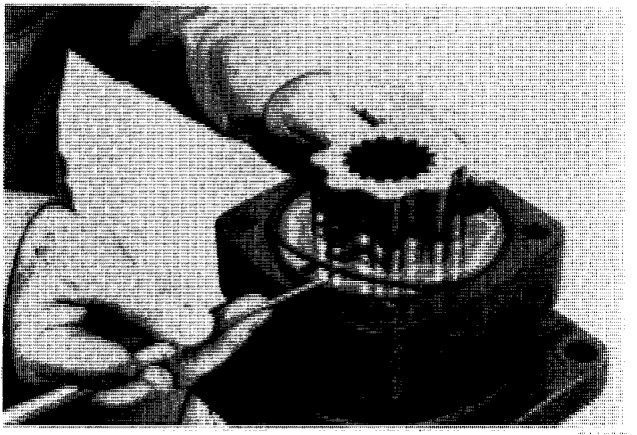
**STEP 24**

Remove the O-ring.

**STEP 71**

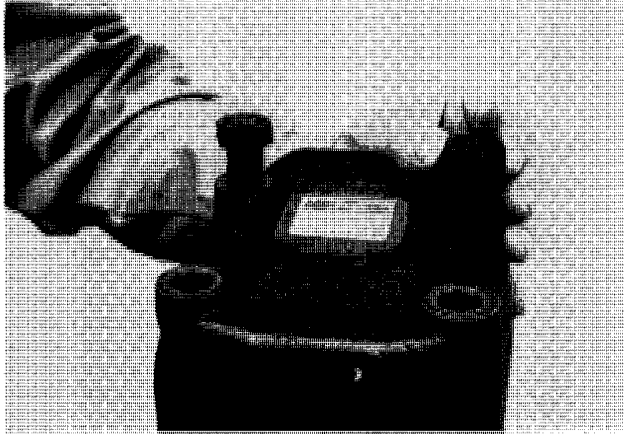

707020

Install the cap screws at the port side of the port end cover.

**STEP 72**

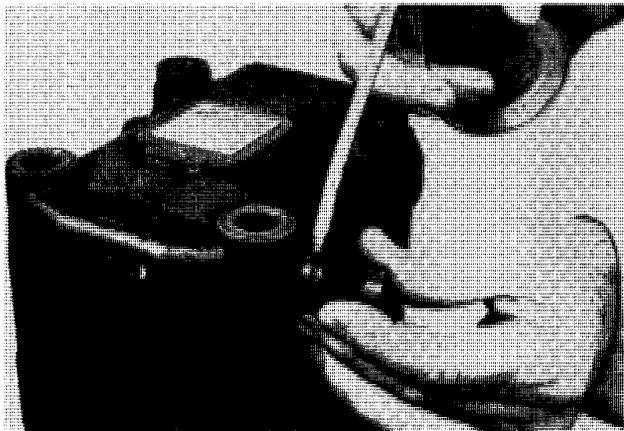

707026

Lubricate a plug and the O-ring with clean oil.

**STEP 73**



707030

Align the plug with the hole for the cap screw and use a soft hammer to drive the plug into the port end cover.

**STEP 74**



707032

Install a cap screw.

**STEP 75**

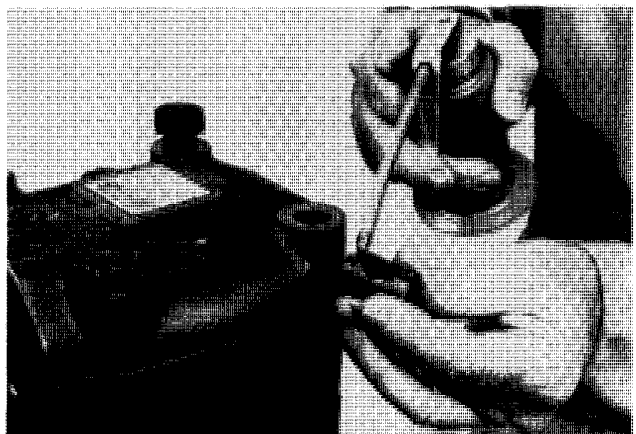

707034

Lubricate the other plug and O-ring with clean oil.

**STEP 76**



707036

Use a C-clamp to push the plug into the bore and install the cap screw.

## GENERAL INFORMATION

### Chain Lubrication

Each chain compartment is filled with 6 U.S. quarts (5.7 litres) of 10W-30 engine oil.

After 500 hours of operation or yearly, drain the oil from the chain compartments and flush each chain compartment with clean diesel fuel. Then fill each chain compartment.

### When to Replace a Chain

A chain must be replaced when the axle housing cannot be moved in the slots to tighten the chain.

DO NOT remove a link to shorten the chain.

## CHECKING DEFLECTION OF A CHAIN

The deflection of the chains must be checked after every 250 hours of operation.

### STEP 1

Raise the wheels off the floor and use blocks to hold the machine in place. Loosen and remove the wheel nuts and wheels.

### STEP 2

Loosen and remove the nuts, lock washers and flat washers that hold the cover for the motor sprocket.

### STEP 3

Before removing the cover, loosen the plug in the cover. The plug will be removed during installation to help install the cover.

### STEP 4

Remove the cover.

### STEP 5

If the gasket is damaged, remove the gasket from the frame (or cover).

### STEP 6

Check the deflection of the chains. The deflection of the chains cannot be measured with accuracy. Move the chain up and down and make an estimate of the amount of deflection. If the deflection is 1-1/2 inch (38 mm) or more for one chain, adjust the deflection of all chains.

### STEP 7

Do not install the covers or wheels until the chains have been adjusted.

### STEP 8

If necessary, install a new gasket for the cover.

### STEP 9

Remove the plug from the cover.

### STEP 10

Align the needle bearing with the shaft and push the cover onto the studs.

### STEP 11

Install the flat washers, lock washers and nuts and tighten the nuts. Install the plug in the cover.

### STEP 12

Install the wheels and wheel nuts.

### STEP 13

Tighten the wheel nuts to 80 to 90 pound-feet (110 to 120 Nm).

### STEP 14

Remove the blocks and lower the wheels to the floor.

**STEP 121**

Install the hardened washer and nut.

**STEP 122**

Prevent the axle from turning and tighten the nut to 75 to 95 pound-feet.

**STEP 123**

Check to see that the axle has no end play. If there is end play, tighten the nut a small amount.

**STEP 124**

Install a new cotter pin. If a hole and a notch are not aligned, tighten the nut to align a notch with a hole.

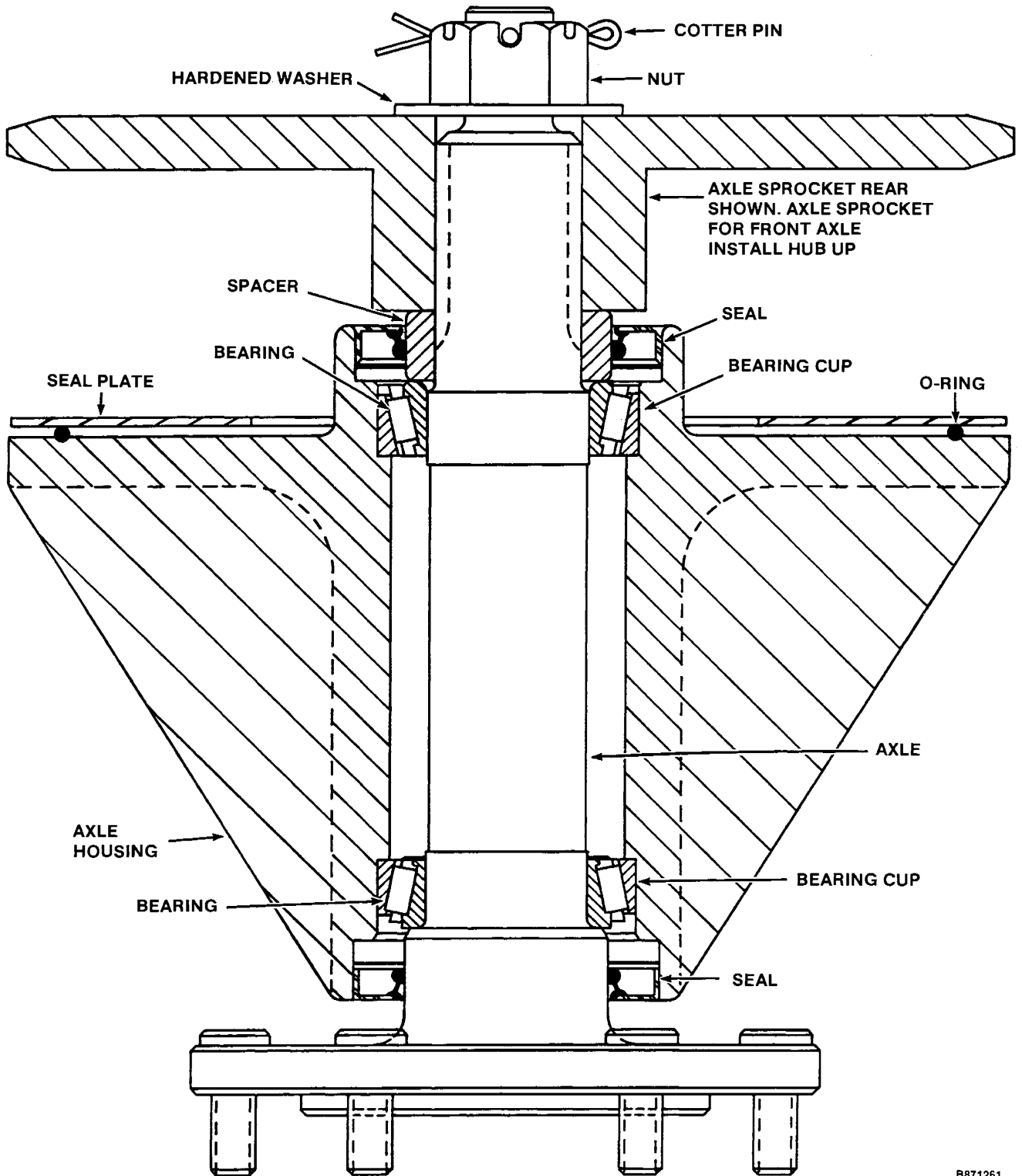

10. Install the yoke on the cross.

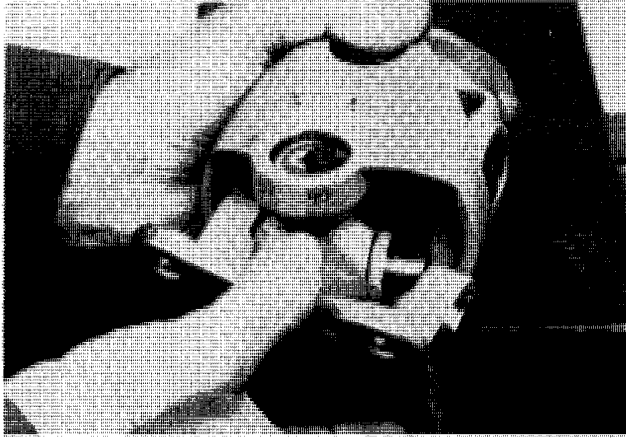

11. Put a support below the yoke and press the top bearing cap into the yoke until the bearing cap is just above the end of the cross.

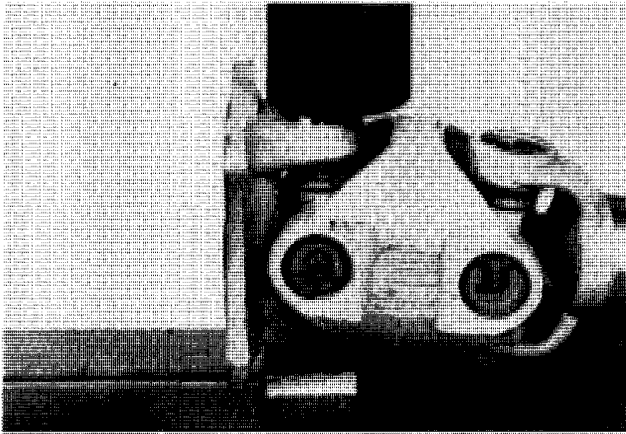

12. Carefully raise the cross into the top bearing cap and press the bearing cap into the yoke.

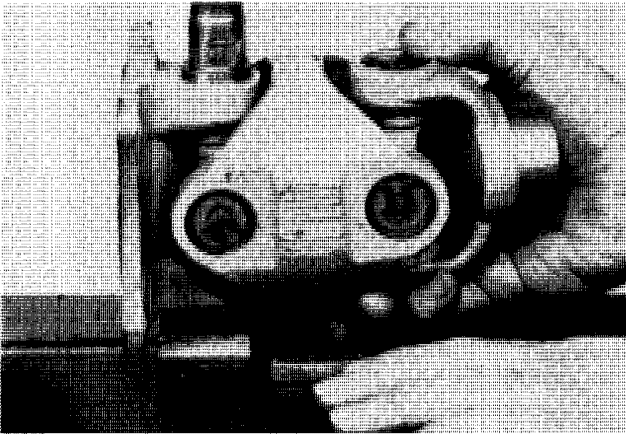

13. Press the bearing cap into the yoke until the groove for the snap ring can be seen.

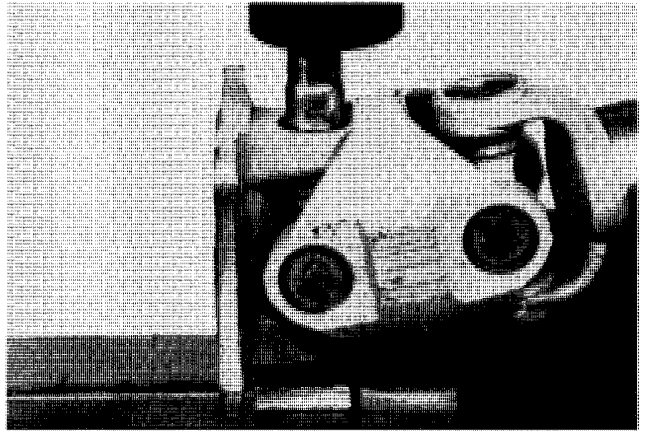

14. Install a snap ring.

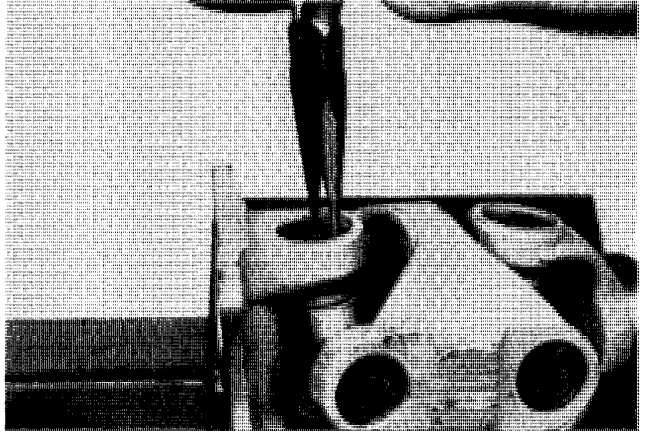

15. Press the other bearing cap into the yoke until the groove can be seen.

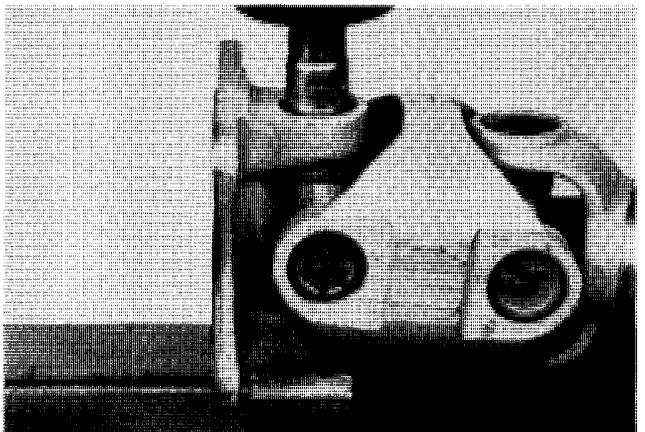

16. Install a snap ring.

## LOADER CONTROL VALVE

### Removal

#### STEP 1

Raise the loader frame and install the support strut.

#### STEP 2

See Section 9003 and move the operators compartment forward.

#### STEP 3

Remove the cap from the hydraulic reservoir.

#### STEP 4

Connect a vacuum pump to the hydraulic reservoir.

#### STEP 5

Start the vacuum pump. Disconnect the hoses and tubes from the fittings in the loader control valve.

#### STEP 6

Loosen and remove the self-locking nuts, flat washers, and bolts from the loader control valve. Remove the ground wire from the front bolt.

#### STEP 7

Move the tubes away from the fittings as necessary and remove the loader control valve.

#### STEP 8

Install plugs in the hoses and tubes to keep dirt out of the hydraulic system.

#### STEP 9

Stop the vacuum pump.

### Installation

#### STEP 1

Start the vacuum pump. Remove the plugs from the hoses and tubes.

#### STEP 2

Put the loader control valve on the mounting plate. Install the bolts, flat washers, and self-locking nuts to fasten the loader control valve in place. Make sure that the ground wire is connected to the front mounting bolt of the loader control valve.

#### STEP 3

Connect the hoses and tubes to the fittings in the loader control valve.

#### STEP 4

Stop the vacuum pump.

#### STEP 5

Disconnect the vacuum pump from the hydraulic reservoir.

#### STEP 6

Move the operators compartment into the OPERATING position according to the instructions in Section 9003.

#### STEP 7

Start and run the engine at idle. Operate the loader control levers to completely extend and retract the lift and bucket cylinders to remove any air from the hydraulic system.

#### STEP 8

Lower the loader bucket to the floor. Stop the engine.

#### STEP 9

Check for oil leakage. Check the level of the oil in the hydraulic reservoir. Add oil as necessary.

## MAIN RELIEF VALVE

### Test Point 1

1. Heat the oil to operating temperature.
2. Lower the bucket to the floor and stop the engine.
3. Connect the pressure gauge to the tube at test point 1. Install a cap on the fitting.
4. Run the engine at full throttle. Hold the loader control in the LOWER position.
5. The gauge must show 2150 to 2250 psi (14 824 to 15 513 kPa, 146 to 153 bar).
6. If the pressure is not correct, replace the main relief valve in the loader valve.

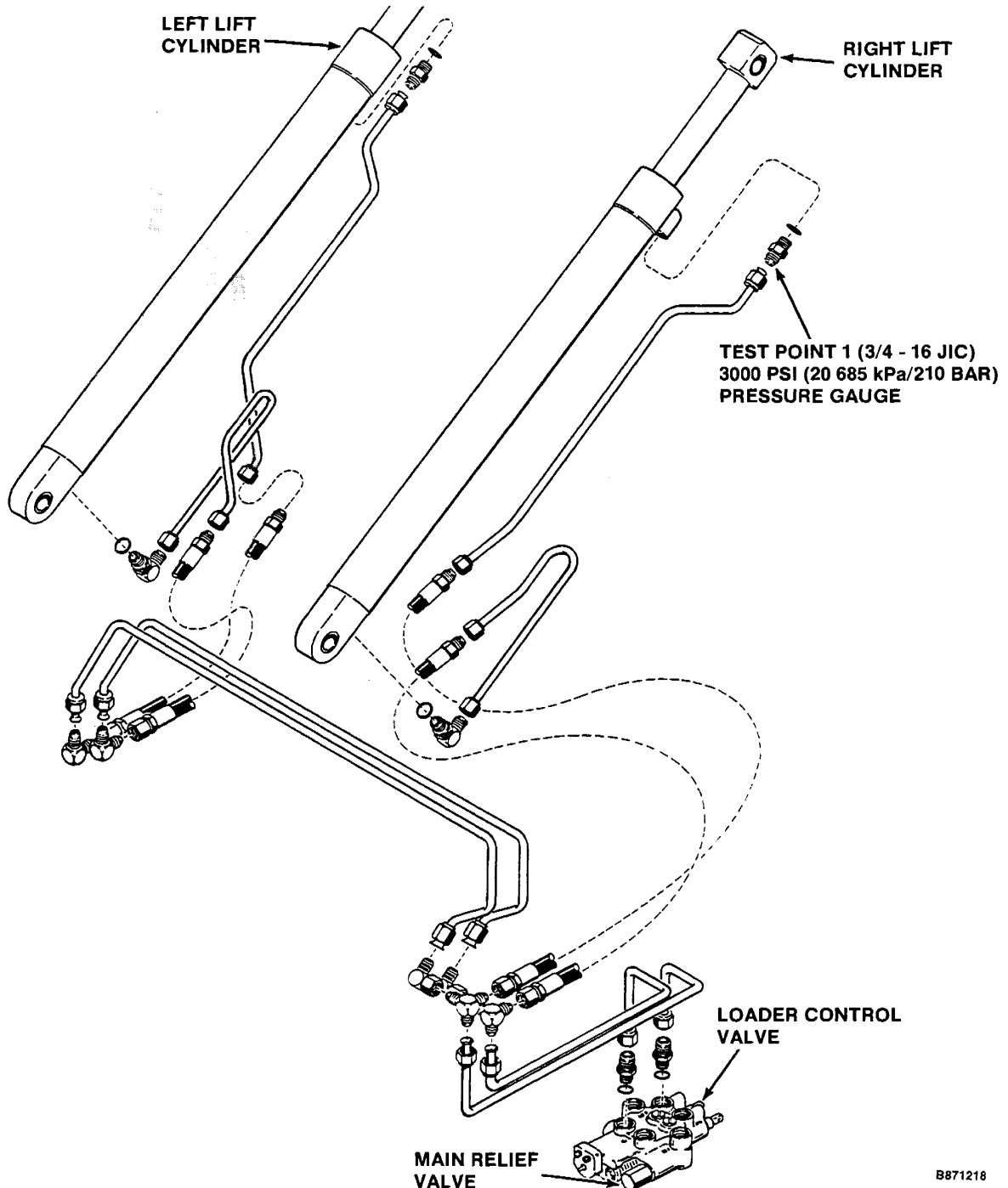

## DISASSEMBLY

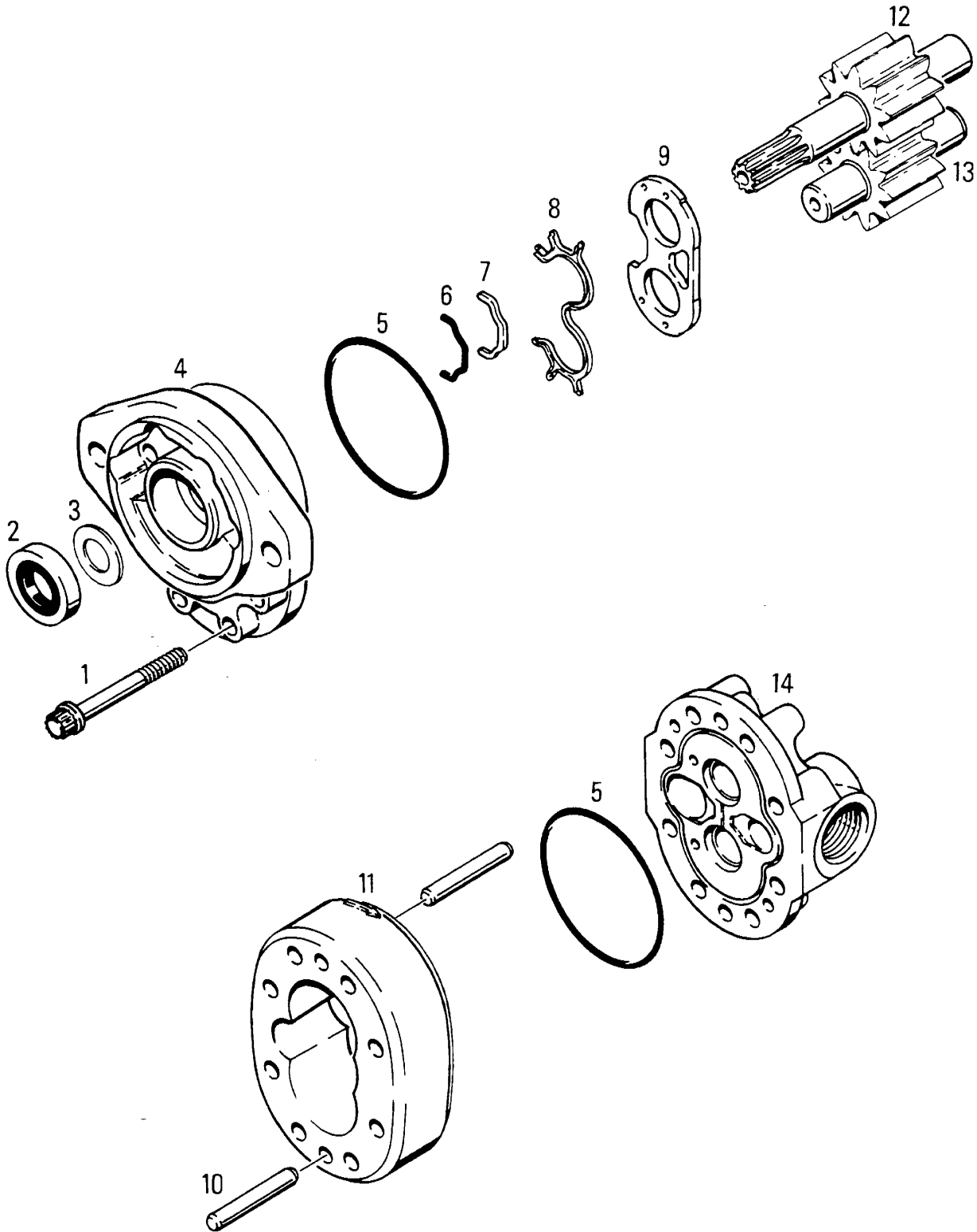

851127

- 1. Ferry Head Screw
- 2. Seal
- 3. Washer
- 4. Drive End Cover

- 5. O-ring
- 6. Backup Seal
- 7. Bearing Seal

- 8. Pressure Seal
- 9. Wear Plate
- 10. Dowel Pin

- 11. Gear Housing
- 12. Drive Gear
- 13. Driven Gear
- 14. Port End Cover

**NOTE:** The following photographs show a thin head on the main relief valve. Your main relief has a thick head. See the illustration (item 16) on page 8005-3.

1. Prevent the bucket spool from turning. Loosen and remove the cap screw.

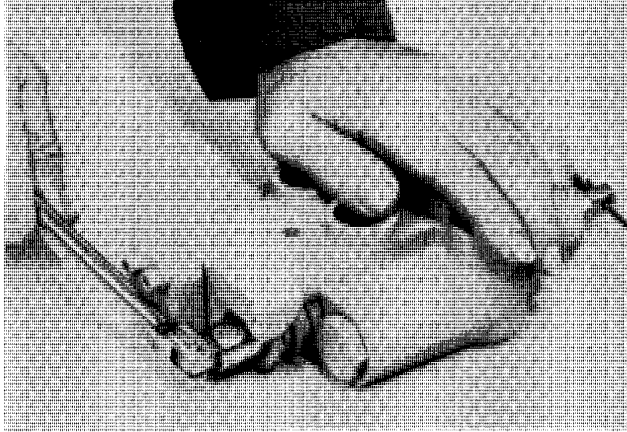

313733

2. Push the bucket spool out of the body approximately 1/2 inch (13 mm).

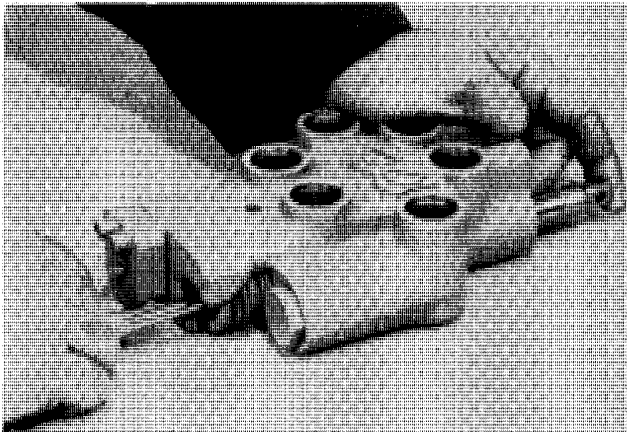

313734

3. Remove the spring seats, centering spring, and spacer.

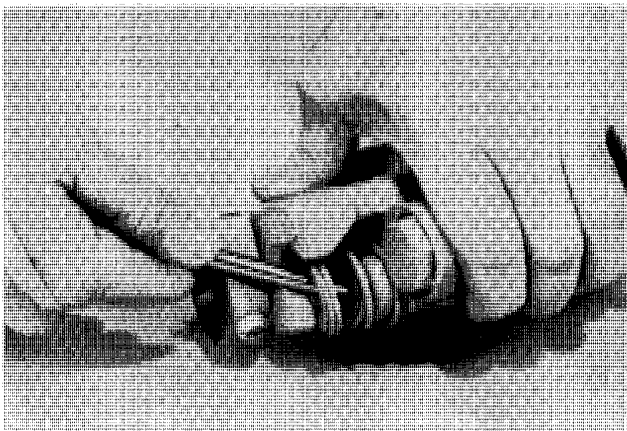

313735

4. Remove the O-ring from the groove in the bore.

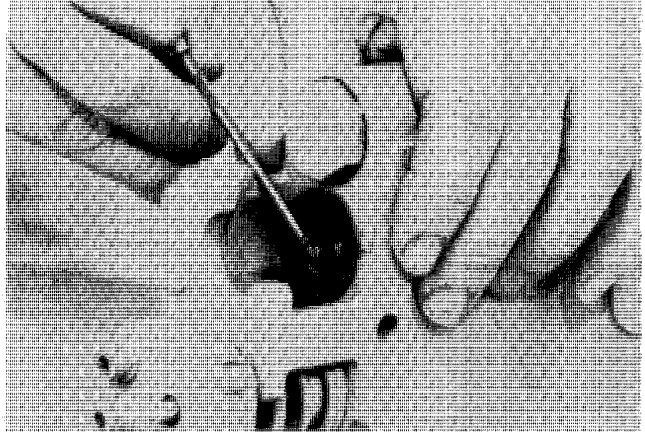

313736

5. Remove the bucket spool.

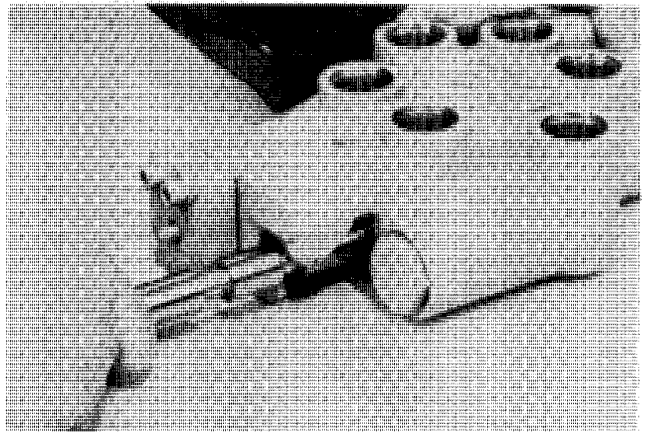

313737

6. Remove the O-ring from the other end of the bore.

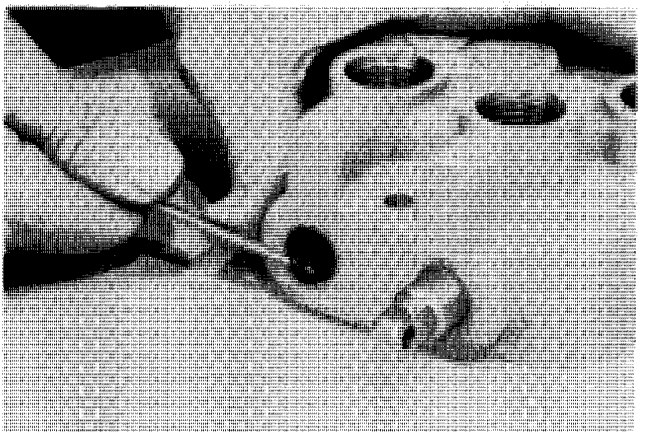

313738

31. Tighten the cap screw to 5 to 8 pound-feet (7 to 11 N m, 0.7 to 1.1 kg/m).

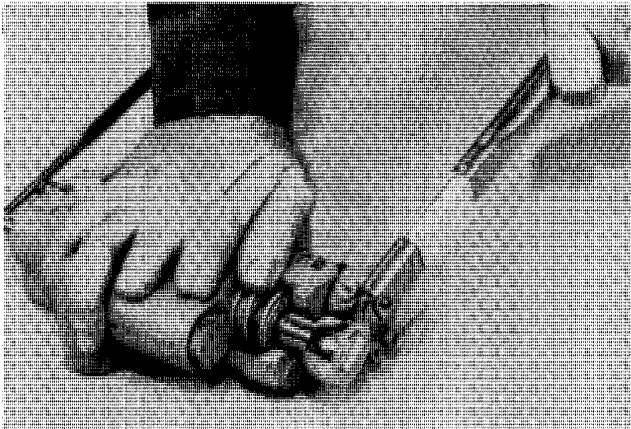

313835

32. If the fittings were removed from the body, make sure that the restrictor is installed in the B port of the lift spool. The groove in the restrictor must be on top.

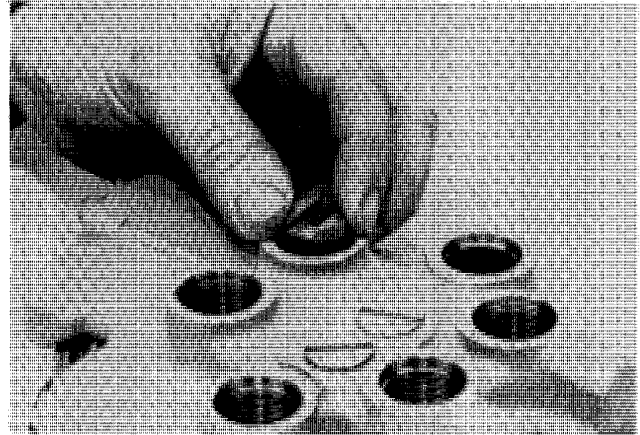

313836

## SPECIFICATIONS

**Torque for gland with lock screw** ..... 100 to 400 pound-feet (135 to 542 Nm)

**Torque for gland for grapple cylinder** ..... 75 to 85 pound-feet (101 to 115 Nm)

	Torque for Cap Screws with 242 (Blue) Loctite on Threads	Approximate Weight
<b>Loader Cylinders</b>		
Lift Cylinder	270 to 340 pound-feet (365 to 460 Nm)	45 pounds (20 kg)
Bucket Cylinder	270 to 340 pound-feet (365 to 460 Nm)	28 pounds (13 kg)
<b>D100 Backhoe Cylinders</b>		
Stabilizer Boom, Dipper and Bucket Cylinders	270 to 340 pound-feet (365 to 460 Nm)	44 pounds (20 kg)
D100 Swing Cylinder		
<b>Torque for Nuts</b>		
<b>Grapple Cylinder</b>	77 pound-feet (104 Nm)	25 pounds (11 kg)

## Inspection

### STEP 1

Discard the parts removed from the gland, piston, and piston rod.

### STEP 2

Clean all parts in cleaning solvent.

### STEP 3

Illuminate the inside of the tube. Inspect the inside of the tube for deep grooves and other damage. If there is damage to the tube, a new tube must be used.

### STEP 4

Check to be sure that the piston rod is straight. If the piston rod is not straight, install a new piston rod.

### STEP 5

Remove small scratches on the piston rod or inside the tube with emery cloth of medium grit. Use the emery cloth with a rotary motion.

### STEP 6

Inspect the gland for rust and clean and remove rust as necessary.

### STEP 7

Inspect the bushings in the piston rod eye and tube, and replace as required.

### STEP 8

Inspect the gland end of the tube for sharp edges that will cut the gland O-ring and remove as necessary.

### STEP 9

Inspect the piston for damage and wear. If the piston is damaged or worn, a new piston must be used.

## Assembly

### STEP 1

Install a new seal in the bore of the gland. The seal is to be installed so that the lips of the seal are toward the inner end of the gland. The seal can be difficult to install. Use tools that will not damage the seal.

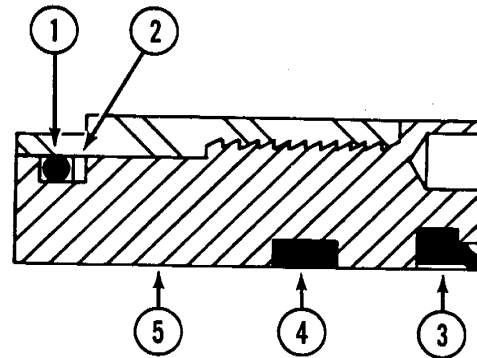

870323

1. O-ring

2. Backup Ring

3. Wiper

4. Seal

5. Gland

### STEP 2

Press a new wiper into the bore of the gland.

### STEP 3

Install a new backup ring in the groove in the gland. If the backup ring is not flat on both sides, the side that is not flat must be toward the O-ring.

### STEP 4

Install a new O-ring in the groove in the gland.

### STEP 5

Fasten the piston rod eye in the vise.

### STEP 6

Remove any marks and sharp edges on the chamfer at the end of the piston rod.

## REMOVING THE LOADER FRAME

### STEP 1

Park the machine on a level surface.

### STEP 2

Clean the connections to the bucket cylinders at the top of the right loader frame. If the machine is equipped with an auxiliary hydraulic circuit, clean those connections also.

### STEP 3

Raise the loader frame high enough so the pivot pins for the piston rod eyes of the lift cylinders can be removed through the screens and put a support below the loader frame.

### STEP 4

Remove the snap ring and flat washer from the pivot pin for the left piston rod eye.

### STEP 5

Drive the pivot pin out of the loader frame. Do not remove the driver now.

### STEP 6

Remove the snap ring and flat washer from the pivot pin for the right piston rod eye.

### STEP 7

Drive the pivot pin out of the loader frame. Do not remove the driver now.

### STEP 8

Lower the loader frame onto blocks that are 9 inches (229 mm) high. The blocks must be used on each side of the loader frame. If the bucket is installed, put a support below the bucket to keep the bucket level.

### STEP 9

Hold the right lift cylinder and remove the driver from the piston rod eye only. Lower the lift cylinder.

### STEP 10

Remove the pins that hold the strut in position and lower the strut.

### STEP 11

Remove the driver and the strut.

### STEP 12

Hold the left lift cylinder and remove the driver. Lower the lift cylinder.

### STEP 13

Connect acceptable lifting equipment to the loader frame.

### STEP 14

Loosen and remove the self-locking nut and bolt from the pivot pin for the left loader frame.

### STEP 15

Drive the pivot pin out of the frame.

### STEP 16

Repeat steps 14 and 15 for the right loader frame.

### STEP 17

Fasten identification tags to the hoses and tubes at the top of the right loader frame.

### STEP 18

Disconnect the hoses from the tubes.

### STEP 19

Install caps on the hoses and plugs in the tubes.

### STEP 20

If the machine is equipped with an auxiliary hydraulic circuit, do steps 21 through 23.

### STEP 21

Fasten identification tags to the hoses and tubes.

### STEP 22

Disconnect the hoses from the tubes.

### STEP 23

Install caps on the hoses and plugs in the tubes.

### STEP 24

Raise the loader frame out of the bosses in the frame.

### STEP 25

Carefully move the machine out of the loader frame.

## ACCIDENT DAMAGE TO ROPS CANOPY

If the machine has rolled over or the ROPS canopy has been in some type of accident (such as hitting an overhead object during transport), you must replace the ROPS canopy to have the same protection you had with the original ROPS canopy.

After the accident check for damage to the ROPS canopy, seat belt, accessories, and wiring in the ROPS canopy. Before operating the machine, replace all damaged parts.

DO NOT try to weld or straighten the ROPS canopy.

## MAINTENANCE AND INSPECTION OF ROPS CANOPY

After every 500 hours of operation or every six months, whichever occurs first, do the following:

### STEP 1

Check the torque for the mounting bolts of the ROPS canopy. See illustration on page 9003-3 for torque specifications.

### STEP 2

Check the torque for the mounting bolts for the seat belts. See illustration on page 9003-4 and 9003-5 for torque specifications.

### STEP 3

If a seat belt is damaged in anyway, replace the seat belt.



***Do not install attachments that will make the total weight of the machine more than the weight shown in the maximum gross vehicle weight section of the ROPS serial number plate.***

47-26



***Do not change the ROPS in any way. Changes made to the ROPS which are not authorized, such as welding, drilling or cutting will make the ROPS weaker and decrease your protection. Replace the ROPS if it becomes damaged in any way. DO NOT TRY TO MAKE REPAIRS TO THE ROPS.***

47-25

CLICK HERE TO **DOWNLOAD** THE COMPLETE MANUAL

- Thank you very much for reading the preview of the manual.
- You can download the complete manual from: [www.heydownloads.com](http://www.heydownloads.com) by clicking the link below



- Please note: If there is no response to CLICKING the link, please download this PDF first and then click on it.

CLICK HERE TO **DOWNLOAD** THE COMPLETE MANUAL