

X 325 X 328

Excavator

Service Manual

325 (S/N 514013001 & Above)
328 (S/N 516611001 & Above)

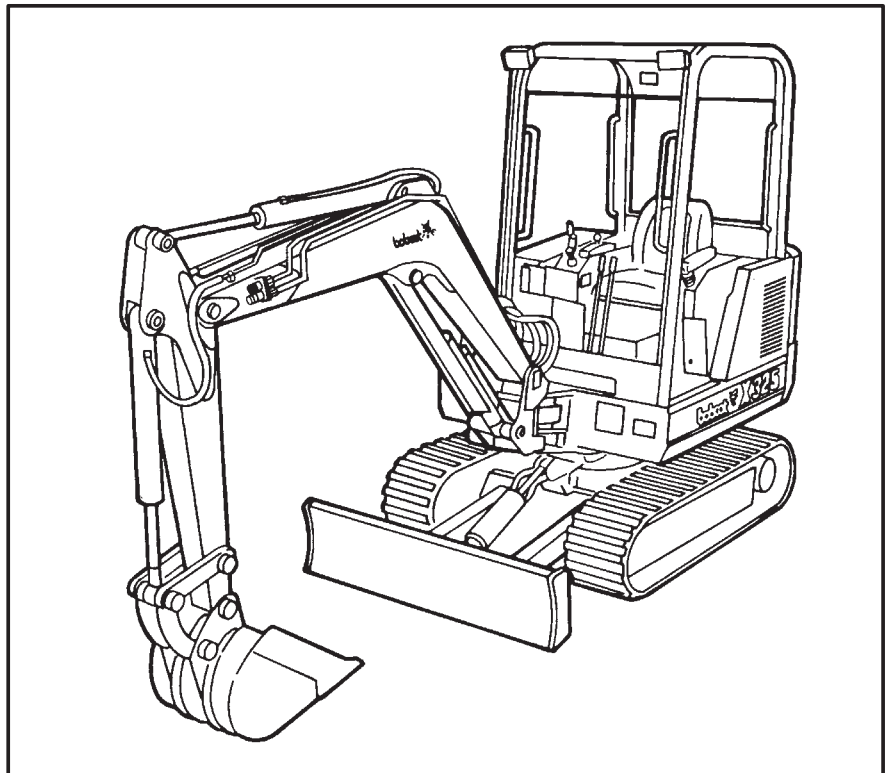

MELROE
INGERSOLL-RAND

6900462(3-98)

 **bobcat**[®]
© Melroe Company 1998
Printed in U.S.A.

CLICK HERE TO **DOWNLOAD** THE COMPLETE MANUAL

- Thank you very much for reading the preview of the manual.
- You can download the complete manual from: www.heydownloads.com by clicking the link below



- Please note: If there is no response to CLICKING the link, please download this PDF first and then click on it.

CLICK HERE TO **DOWNLOAD** THE COMPLETE MANUAL

SAFETY INSTRUCTIONS

WARNING

Instructions are necessary before operating or servicing machine. Read Operation & Maintenance Manual, Handbook and signs (decals) on machine. Follow warnings and instructions in the manuals when making repairs, adjustments or servicing. Check for correct function after adjustments, repairs or service. Failure to follow instructions can cause injury or death.

W-2003-0797

The following publications provide information on the safe use and maintenance of the excavator and attachments:

- The Delivery Report is used to assure that complete instructions have been given to the new owner and that the machine is in safe operating condition.
- The Operation & Maintenance Manual delivered with the excavator gives operating information as well as routine maintenance and service procedures. It is a part of the excavator and must stay with the machine when it is sold. Replacement Operation & Maintenance Manuals can be ordered from your Bobcat Excavator dealer.
- The excavator has machine signs (decals) which instruct on the safe operation and care. The signs and their locations are shown in the Operation & Maintenance Manual. Replacement signs are available from your Bobcat Excavator dealer.
- The Bobcat Hydraulic Excavator has a plastic Operator's Handbook fastened to the operator cab. It's brief instructions are convenient to the operator. The handbook is available from your dealer in an English edition or one of many other languages. See your Bobcat dealer for more information on translated versions.
- The CIMA Safety Manual delivered with the excavator gives information for safe operating and standard signals.
- The Service Manual and Parts Manual are available from your dealer for use by mechanics to do shop-type service and repair work.
- The Bobcat Compact Excavator Operator Training Course is available through your local dealer. This course is intended to provide rules and practices of correct operation of the Hydraulic Excavator.
- The Bobcat Skid-Steer Loader Safety Video is available from your Bobcat Dealer.

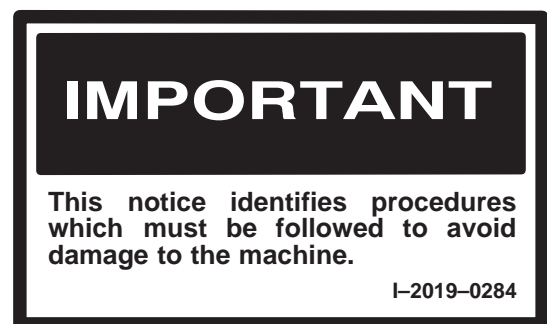

Safety Alert Symbol: This symbol with a warning statement, means: "Warning, be alert! Your safety is involved!" Carefully read the message that follows.

AIR CLEANER SERVICE (Cont'd)

Replacing The Filter Element (325 S/N 514013001–514014899)

See the *SERVICE SCHEDULE*, Page 1–3 for the correct service interval.

Replace the filter element when the red ring shows in the window of the condition indicator (Item 1) [A].

NOTE: Push the button on the condition indicator, start the engine and run the engine at high idle. If the red ring does not show, do not replace the filter element.

Service the air cleaner as follows:

Remove the cover wing nut (Item 1) [B].

Remove the cover (Item 2) [B].

Remove the wing nut (Item 1) [C] at the primary filter element.

Remove the primary filter element [D].

NOTE: Make sure all sealing surfaces are free of dirt and debris.

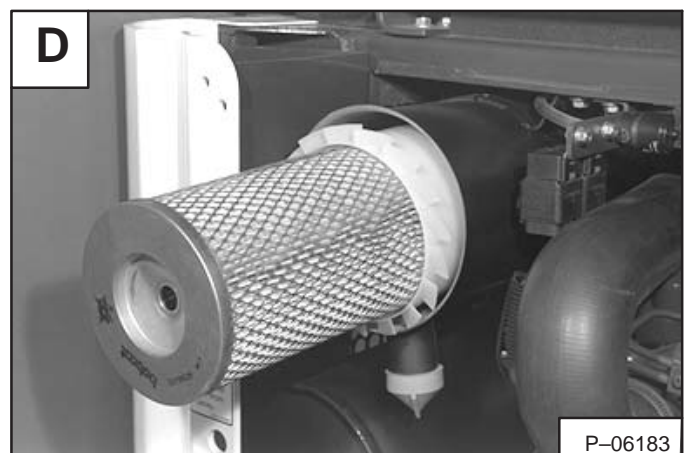
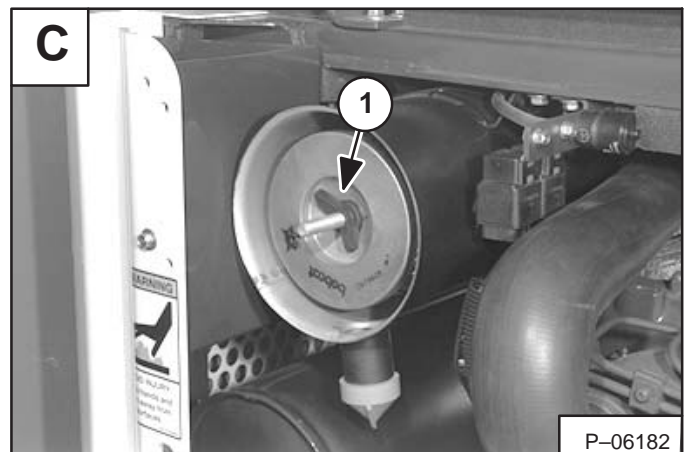
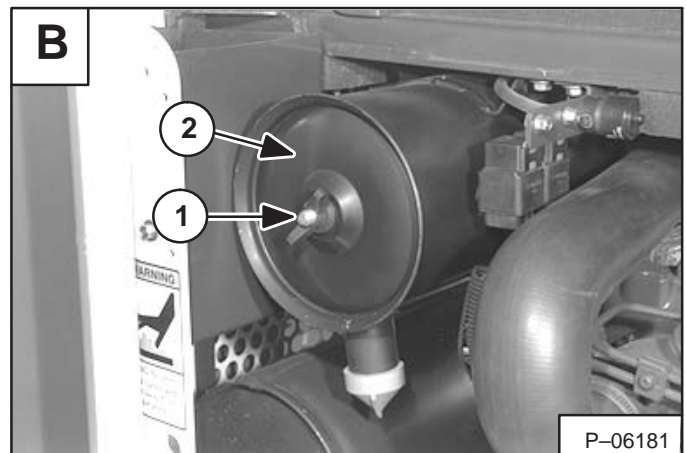
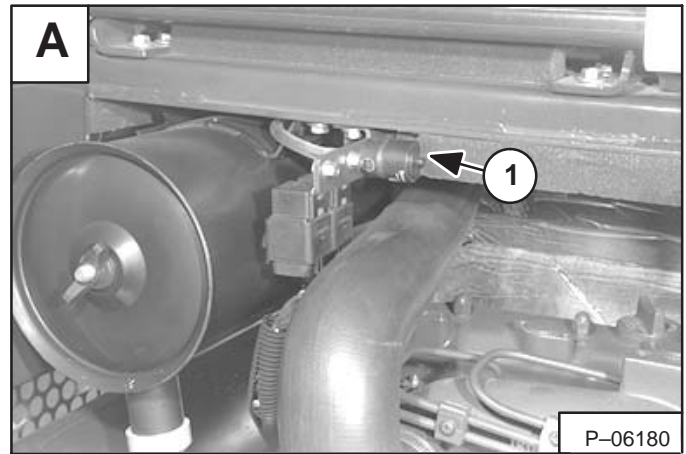

HYDRAULIC SYSTEM

Checking And Adding Fluid

To check and add hydraulic fluid to the reservoir, use the following procedure:

Put the machine on a flat level surface.

Retract the arm and bucket cylinders, put the bucket on the ground and raise the blade. Stop the engine.

Check the hydraulic fluid level, it must be visible in the sight gauge (Item 1) **[A]** located on the side of the hydraulic reservoir.

If the fluid level is not correct, open the hydraulic tank access door **[B]**.

Remove oil fill cap (Item 1) **[B]**.

Check the condition of the fill strainer (Item 1) **[C]**. The screen must be installed in fill neck when adding oil.

Add the correct fluid to the reservoir until it is visible in the sight gauge. (See *FUEL, COOLANT AND LUBRICANTS Chart* Page 8-1.)

Install the reservoir cap, close and lock the access door.

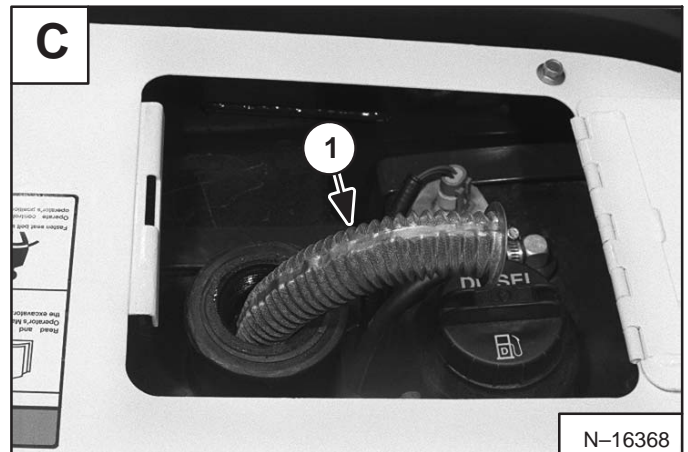
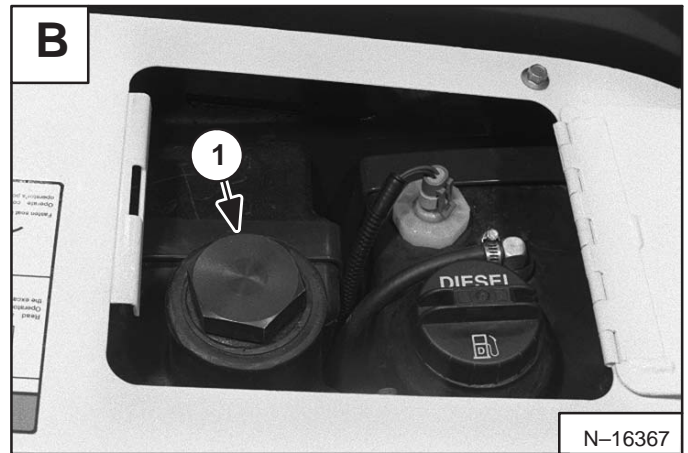
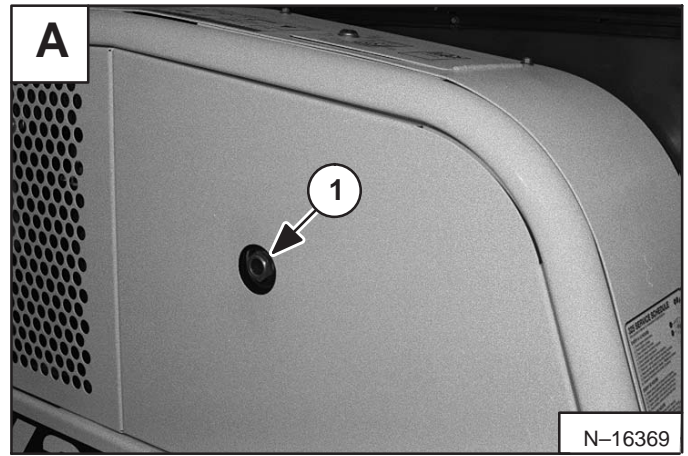

⚠ WARNING

Always clean up spilled fuel or oil. Keep heat, flames, sparks or lighted tobacco away from fuel and oil. Failure to use care around combustibles can cause explosion or fire which can result in injury or death.

W-2103-1285

HYDRAULIC SECTION

Page
Number

**HYDRAULIC
SYSTEM**

ACCUMULATOR	
Assembly (S/N 514013001 – 17331 & 516611001 – 11918)	2-76
Assembly (S/N 514017332 & Above & 516611919 & Above)	2-82
Disassembly (S/N 514013001 – 17331 & 516611001 – 11918)	2-74
Disassembly (S/N 514017332 & Above & 516611919 & Above)	2-80
Parts Identification (S/N 514013001 – 17331 & 516611001 – 11918)	2-73
Parts Identification (S/N 514017332 & Above & 516611919 & Above)	2-79
Removal and Installation	2-72
Testing	2-85
ARM CYLINDER	
Parts Identification	2-98
Removal and Installation	2-97
AUXILIARY SELECTOR VALVE	
Disassembly and Assembly	2-90
Removal And Installation (325 S/N 514013001-514014899)	2-89
Removal And Installation (325 S/N 514014900 & Above) & (328 S/N 516611001 & Above)	2-89
BLADE CYLINDER	
Parts Identification	2-101
Removal and Installation	2-101
BOOM CYLINDER	
Parts Identification	2-96
Removal and Installation	2-95
BOOM CYLINDER SHIELD	
Removal and Installation	2-95
BOOM SWING CYLINDER	
Parts Identification	2-103
Removal and Installation	2-102
BUCKET CYLINDER	
Parts Identification	2-100
Removal and Installation	2-99
BUILD UP VALVE	
Description	2-88
Disassembly And Assembly	2-88
Removal And Installation	2-88
CASE DRAIN FILTER	
Removal And Installation	2-94
CROSS PORT RELIEF VALVE	
Description	2-20
Testing	2-20

Continued On Next Page

**HYDRAULIC SCHEMATIC
(ISO CONTROLS)**
325 EXCAVATOR (SN 514013001 - 514014899)
 (PRINTED MARCH 1998)
 TS-1361
SHEET 3 OF 3

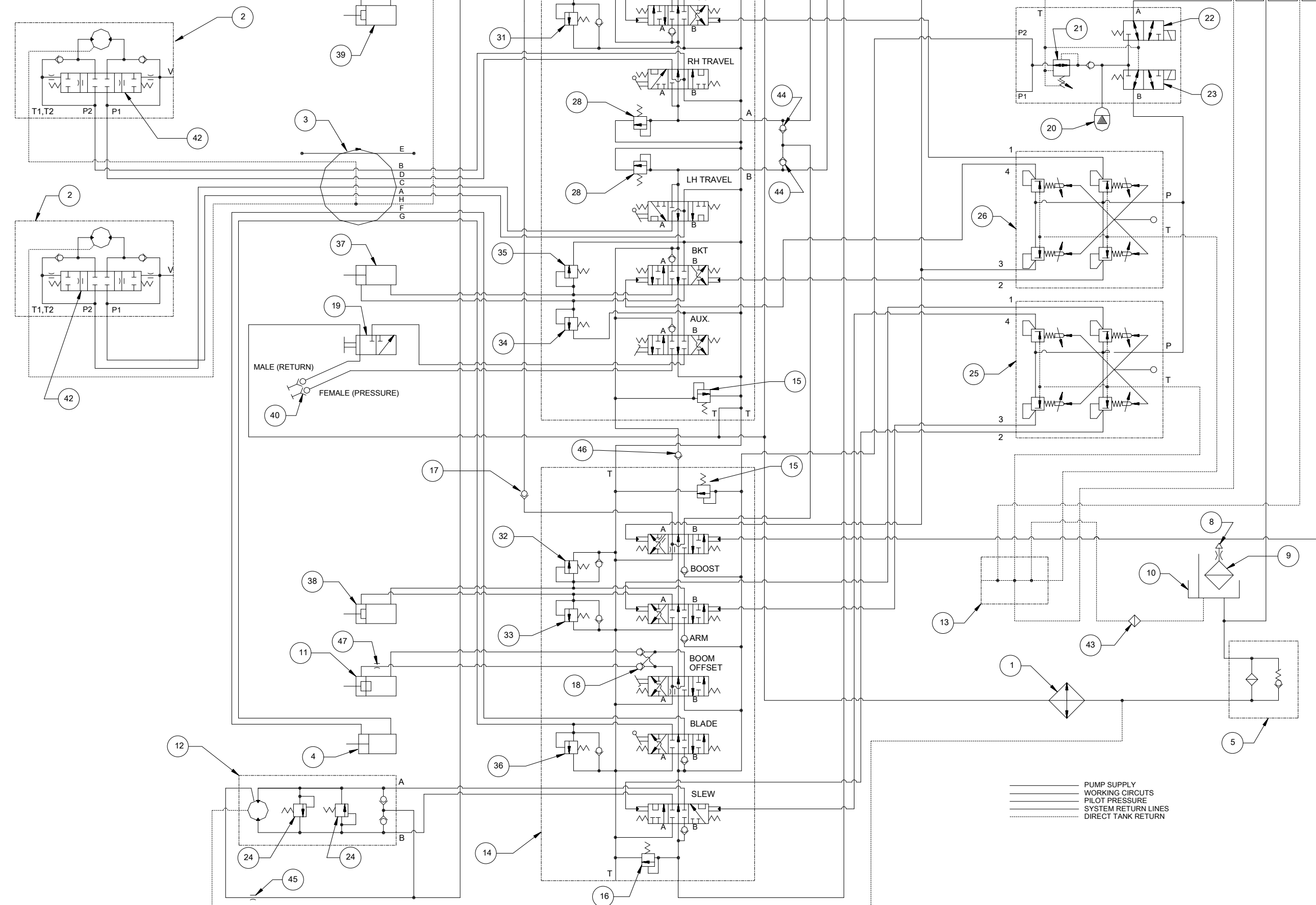

FLUID FLOW EXPLANATION

The fluid flows by gravity from the reservoir [10] through a supply port block [7] to the 3 section hydraulic gear pump [6]. The 3 section gear pumps are coupler driven from the engine. Each gear pump section is protected by a relief valve located in the control valve it supplies.

From the hydraulic pump (Engine flywheel end, pump section 1) fluid is forced to the 5–spool hydraulic control valve [14] Inlet port. Fluid flows through the 5–spool valve [14] power beyond port (boost section) to the second 5–spool valve [29] inlet port. With all spools in the neutral position, the open center control valves [14] & [29] allows the fluid out of the tank port (on 5–spool control valve [29]) to the oil cooler [1], to the oil filter [5] and back to the supply port block [7].

Fluid from the hydraulic pump (center section, pump section 2) is forced to the mid inlet (port B) of the 5–spool valve [29]. These control valve sections operate the left hand travel, bucket and auxiliary.

Fluid from the hydraulic pump (outside section, pump section 3) is forced to the mid inlet port (port A) of the 5–spool valve [29]. These control valve sections operate the right hand travel and boom.

The 5–spool control valves [14] & [29] are composed of series and parallel valve sections.

The swing (slew) valve section of the 5–spool control valve [14] and the left travel and right travel sections of the 5–spool control valve [29] are series valves. Return oil from a series valve section flows internally to the next valve section.

The blade, boom swing, arm and boost valve sections of the 5–spool control valve [14] and the auxiliary, bucket and boom valve sections of the 5–spool control valve [29] are parallel valves.

Return oil from a parallel valve section flows to the reservoir.

The slew (house swing) section on 5–spool control valve [14] is a series section. When the slew section is activated, fluid flows to the swing motor [12] A or B ports and the return fluid feeds the blade, boom swing, arm and boost section of the 5–spool valve [14]. If the swing motor [12] cannot turn, the pressure increases to 1650 PSI (11376 kPa) and opens the swing motor relief valves [24].

When a spool is activated (Blade, Boom Swing or Arm) of the 5–spool control valve [14], the fluid flows to the base or rod end of a cylinder [4], [11], [38]. The fluid on the other side of the cylinder flows back to the control valve [14]. When a cylinder reaches the end of the stroke, the pressure increases to 2650 PSI (18272 kPa) and opens the relief valve [15].

If either one of the swing motor relief valves [24] are activated while a cylinder [4], [11], [38] is at the end of its stroke, the pressure increases to 4200 PSI (28959 kPa) and opens the main relief valve [16].

HYDRAULIC SYSTEM TROUBLESHOOTING (Cont'd)

TROUBLESHOOTING THE TRAVEL CIRCUIT (Cont'd)		
PROBLEM	CAUSE	CORRECTION
Machine not running straight.	Lever linkage incorrectly adjusted.	Readjust.
	Track tension not equal.	Readjust.
	Pump output not equal.	Repair or replace.
	Travel motor internal leakage not equal.	Repair or replace.
	Travel motor counterbalance spool sticking.	Repair or replace.
	Main relief valve pressure set too low.	Repair or replace.
	Swivel joint internal leakage excessive.	Repair or replace.
	Control valve internal leakage not equal.	Repair or replace.
Machine will not hold on slope or while digging.	Track motor counterbalance valve leakage excessive.	Repair or replace.
	Hose damage.	Replace.
Blade drops while machine is moving.	Lever linkage misadjusted.	Readjust.
	Cylinder internal leakage excessive.	Repair or replace.
	Control valve internal leakage excessive.	Repair or replace.
	Swivel joint internal leakage from travel motor pressure circuit into blade cylinder circuit.	Repair or replace.

HYDRAULIC SERVICE INFORMATION (Cont'd)

Checking The Main Relief Valves (Cont'd)

Testing The Right Hand Travel Circuit Relief Valve (Cont'd)

The main relief valve (Item 1) [A], [B] & [C] protects the right travel circuit.

Remove and plug the hose (Item 2) [B] & [C] and fitting from the A port of the right travel section.

Start the engine and run at high idle.

Engage the right travel section circuit in the reverse position.

NOTE: Make sure the blade is to the front of the excavator before engaging the travel circuit.

Continue to engage the right travel circuit. This will cause the main relief valve (Item 1) [A], [B] & [C] to go over relief.

The pressure reading at pump section 3 should be 3700 PSI (25512 kPa). If adjustment is needed See Page 2-53 for *Adjusting The Main Relief Valve*.

When the correct pressure is set, shut off the engine and install the hose (Item 2) [B] & [C] on the A port of the right travel section.

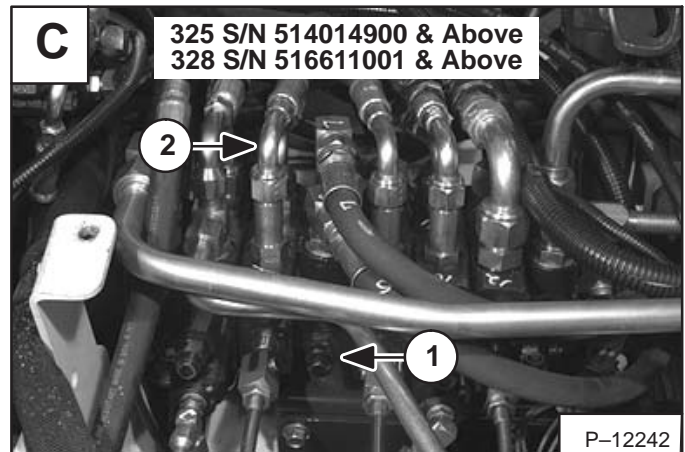
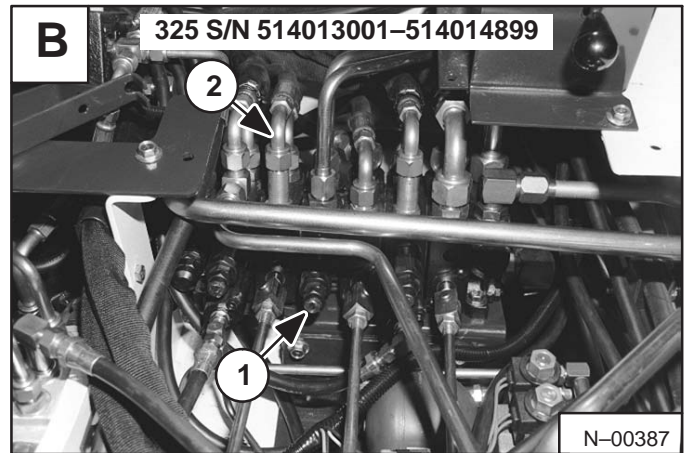
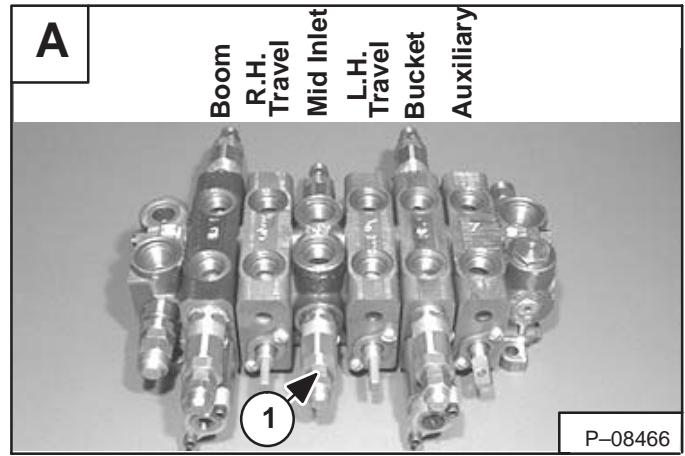

HYDRAULIC PUMP (Cont'd)

Disassembly (Cont'd)

Remove the retaining ring (Item 1) [A] from the mounting flange. Remove the oil seal.

Assembly (325 S/N 514013001–514014899)

All parts must be clean before assembly. Clean all parts in clean solvent and dry with compressed air.

Use the correct size driver and install a new oil seal (seal lips to inside of pump) into the mounting flange. Install the retaining ring (Item 1) [A].

Put a small amount of grease on the seal lips.

Put a small amount of grease in the E-seal groove of each bearing. Install a new E-seal (Item 1) [B] stepped side up, into each E-seal groove. Push each E-seal down into the groove.

Put a small amount of grease on each back-up ring (Item 2) [B]. Install the back-up ring into the groove made by the E-seal and bearing. Push the back-up ring down flush with the E-seal [B].

NOTE: There is a notch (Items 3 & 4) [B] in the center of the back-up ring and E-seal. When installing the back-up ring, make sure that these notches are aligned. If the back-up ring or E-seal is not installed correctly the back-up ring will not be flush with the E-seal.

Put the mounting flange, oil seal side down, in a vise with protective jaws [C].

Install two dowel pins (Item 1) [C] into the mounting flange (or separating plate).

Install the lower bearing, seal side down, on the mounting flange (or separating plate). The open side of the E-seal must point toward the inlet port side (marked side) of the pump [C].

Put tape over the splined end (Item 1) [D] of the drive gear to ensure that the spline will not damage the oil seal during installation.

Apply oil to the drive gear, idler gear and to the side faces of the gears. Install the gears into the lower bearing [D].

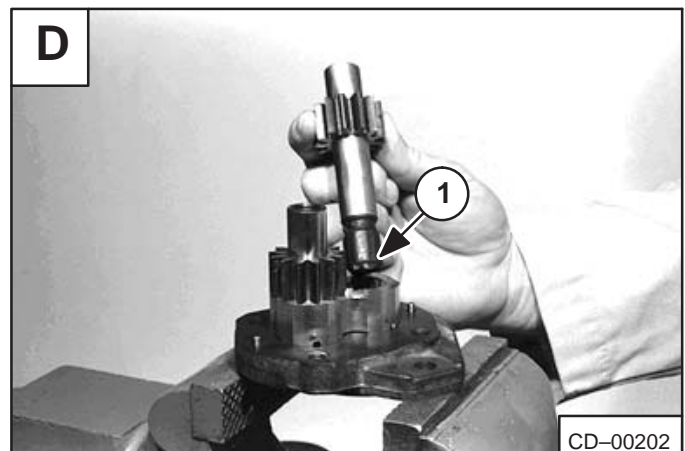
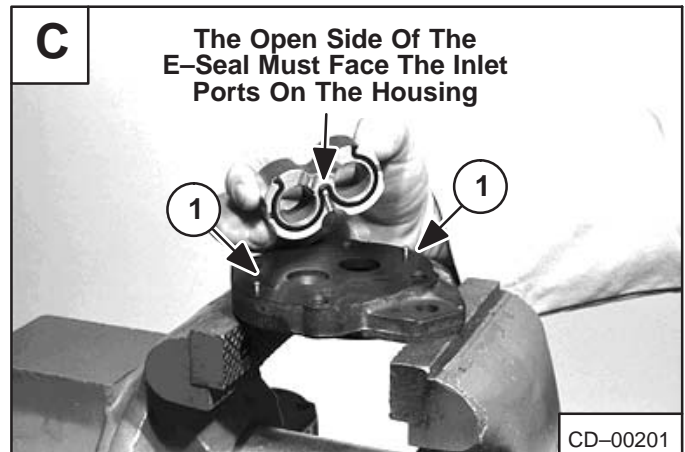
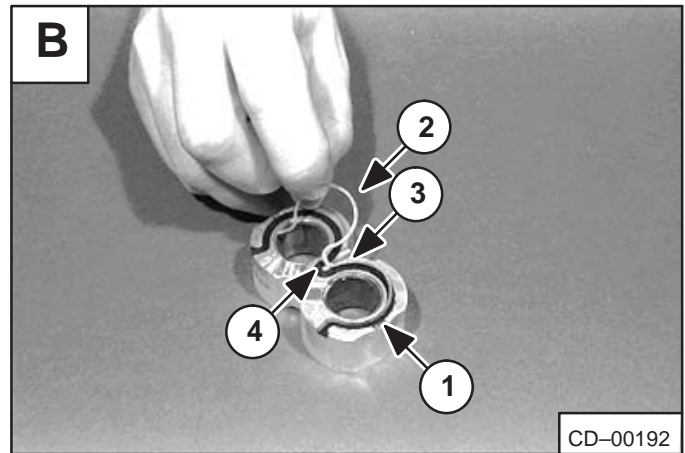
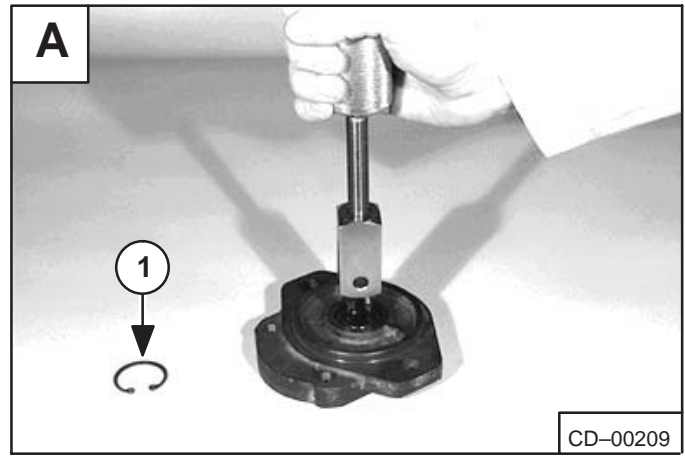

HYDRAULIC CONTROL VALVE (5-Spool) (Cont'd)

Left Travel, Right Travel, Boom, Bucket and Auxiliary (Cont'd)

Left Travel, Right Travel and Auxiliary Disassembly

Put the valve section in a vise with protective jaws.

Remove the two screws (Item 1) [A] from the retaining plate on the actuating end of the spool.

Remove the retaining plate (Item 2) [A].

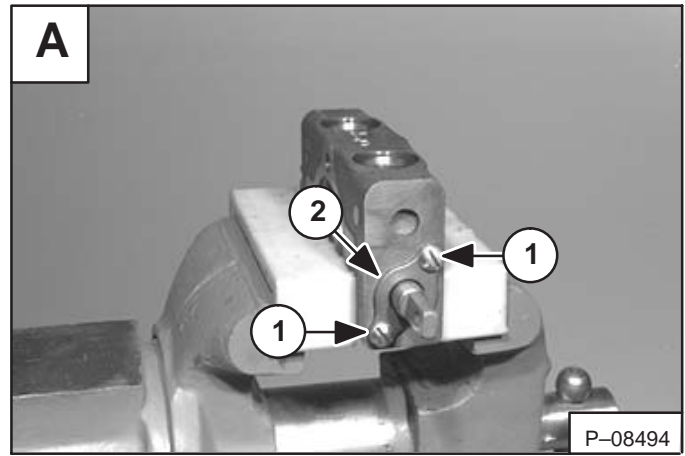

Remove the two screws (Item 1) [B] from the end cap.

Remove the end cap (Item 2) [B].

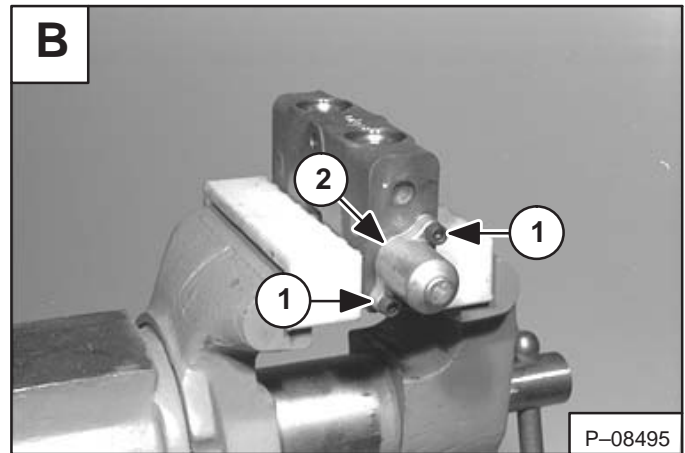

Insert a pin in hole in the actuating end of the spool. Remove the yoke from the spool by holding the pin and turning the spring retaining bolt [C].

NOTE: Only the left and right travel sections have a removable yoke. The auxiliary section yoke is a machined part of the spool.

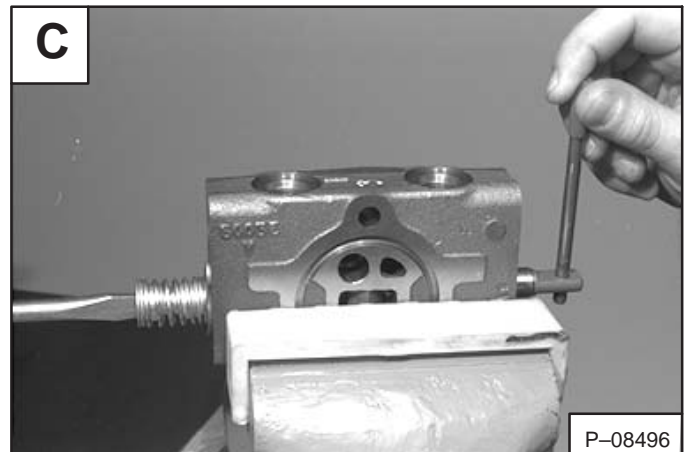

Remove the O-ring (Item 1) [D] from the yoke.

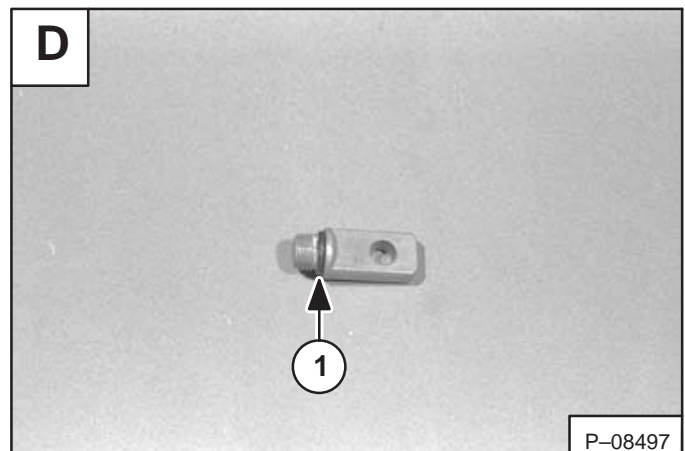

PORT RELIEF VALVES AND MID INLET MAIN RELIEF VALVES (Cont'd)

Port Relief Valve Pressure Setting

Boom Relief set at:
 (Rod End) Front 2950 PSI (20340 kPa)
 (Base End) Rear 3400 PSI (23443 kPa)

Bucket Relief set at:
 (Rod End) Rear 3400 PSI (23443 kPa)
 (Base End) Front 2950 PSI (20340 kPa)

Arm Relief set at:
 (Rod End) Rear 2950 PSI (20340 kPa)
 (Base End) Front 2950 PSI (20340 kPa)

Blade Relief set at:
 (Rod End) Front 3400 PSI (23443 kPa)
 (Base End) Rear None

Mid Inlet Main Relief Valve Pressure Setting:

Mid Inlet Section set at:
 (Rod End) Front 3700 PSI (25512 kPa)
 (Base End) Rear 3700 PSI (25512 kPa)

NOTE: The main relief pressure setting is measured at the hydraulic pump.

Disassembly

Remove the end cap (Item 1) [B] and the O-ring (Item 2) [B] from the adjusting screw (Item 5) [B]. Remove the jam nut (Item 3) [B] and the O-ring (Item 4) [B] from the adjusting screw (Item 5) [B].

Remove the adjusting screw (Item 5) [B], spring (Item 6) [B] and poppet (Item 7) [B] from the housing (Item 8) [B].

Remove the housing (Item 8) [B]. Remove the O-rings (Item 9) [B] and back-up ring (Item 10) [B] from the housing.

Remove the spring (Item 11) [B], poppet (Item 12) [B], pilot pressure poppet (Item 13) [B]. Remove the O-ring (Item 14) [B] and back-up ring (Item 15) [B] from the poppet.

Remove the spring (Item 16) [B] and sleeve (Item 17) [B] from the housing (Item 18) [B].

Remove the O-ring (Item 19) [B] from the housing (Item 18) [B].

Clean all parts in solvent and dry.

Inspect the poppet for scratches or wear at the pilot point. If damage is found, order a new port relief valve assembly from Melroe Parts.

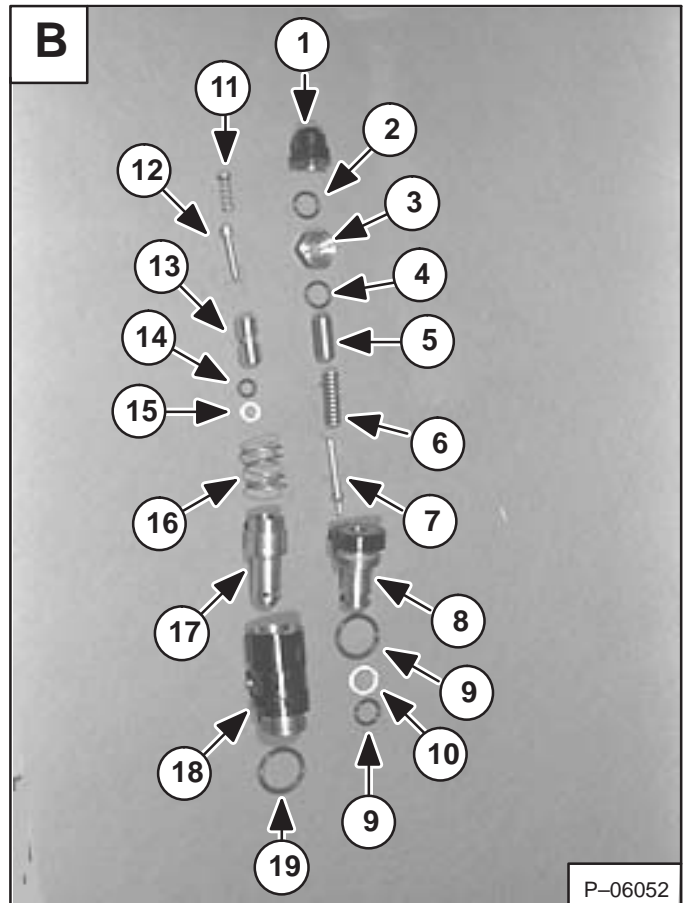
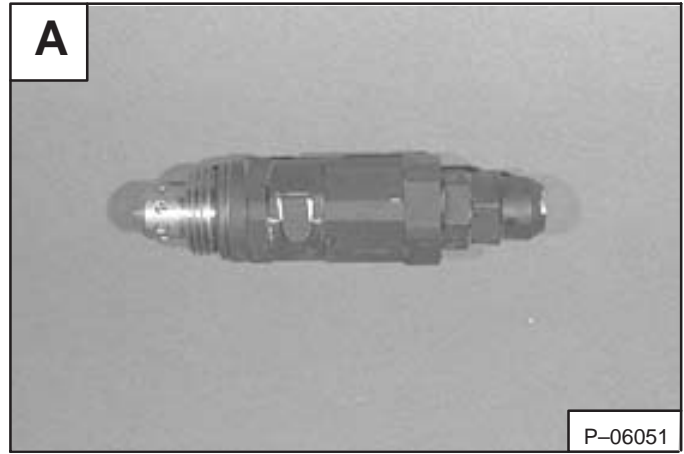

!
WARNING

Wear safety glasses to prevent eye injury when any of the following conditions exist:

- When fluids are under pressure.
- Flying debris or loose material is present.
- Engine is running.
- Tools are being used.

W-2019-1285

HYDRAULIC CONTROL VALVE (5-Spool) (Cont'd)

Boost, Arm, Boom Swing, Blade And Swing Section (Cont'd)

Arm, Boost And Swing Motor Disassembly

Put the valve section in a vise with protective jaws.

Remove the work port relief valve from both ends of the valve section [A].

NOTE: Only the arm section is equipped with work port relief valves.

Installation: Tighten the port relief valve to 30–36 ft.-lbs. (40–48 Nm) of torque.

NOTE: If the relief valve is disassembled the relief pressure setting must be reset. See Page 2–47 for port relief valve repair.

Remove the four screws (Item 1) [B] and retaining plates (Item 2) [B] from both end covers.

Remove the end cover from the end of the valve. Remove the O-ring [C].

Remove the end cover and spool from the valve section [D].

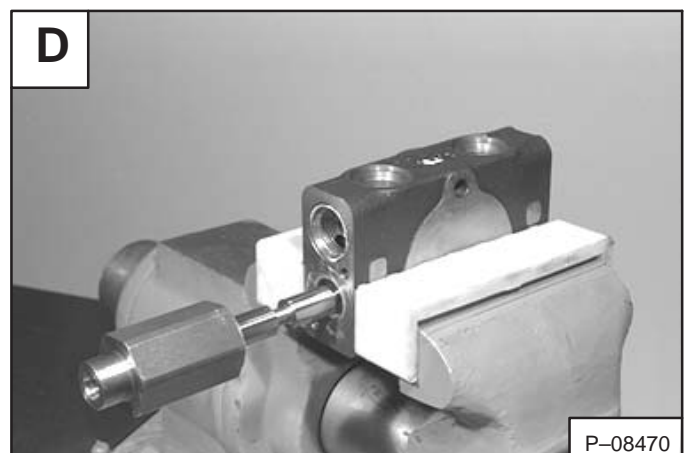
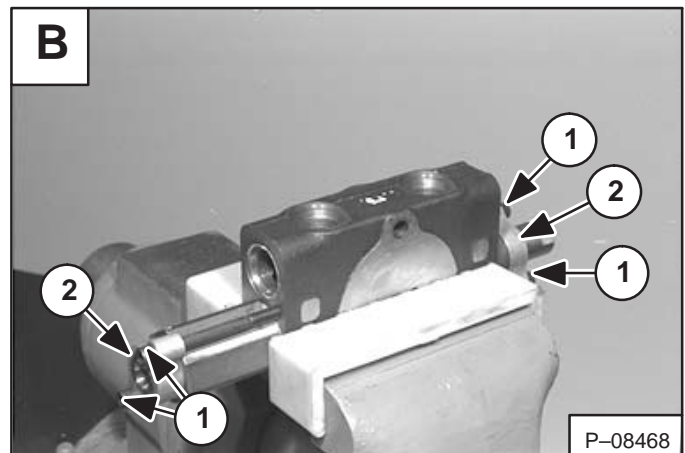
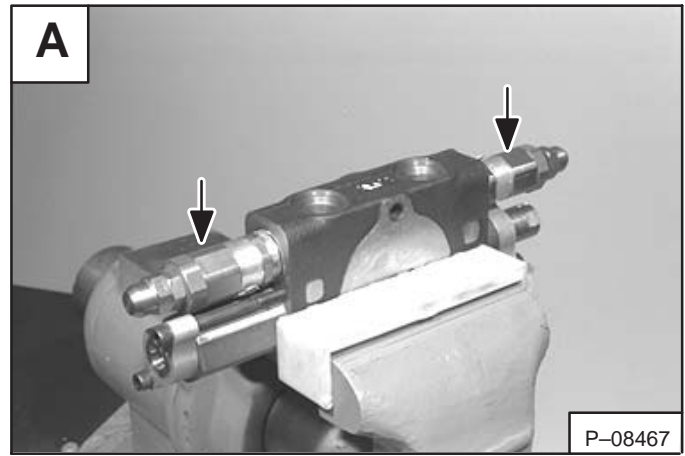

HYDRAULIC CONTROL VALVE (5-Spool) (Cont'd)

Boost, Arm, Boom Swing, Blade And Swing Section (Cont'd)

Blade Disassembly (Cont'd)

Insert a pin into the hole in the actuating end of the spool to retain the spool from turning.

Remove the spring retaining screw from the end of the spool [A].

NOTE: The spring is under pressure, use care when removing the spring retaining screw.

Remove the spring retaining screw (Item 1) [B], the spring retainer (Item 2) [B], the spring (Item 3) [B], the spring retainer (Item 2) [B] and the plate (Item 4) [B].

Remove the wiper (Item 1) [C] from both ends of the spool.

Pull the spool into the housing far enough to remove the spool O-ring from the bore in the valve section [D].

Use a brass tool to remove the O-ring. Do not scratch the bore of the valve section while removing the O-ring or leakage may occur.

Push the other end of the spool into the housing and remove the O-ring from the opposite end.

Check the O-ring gland for contamination and clean as necessary.

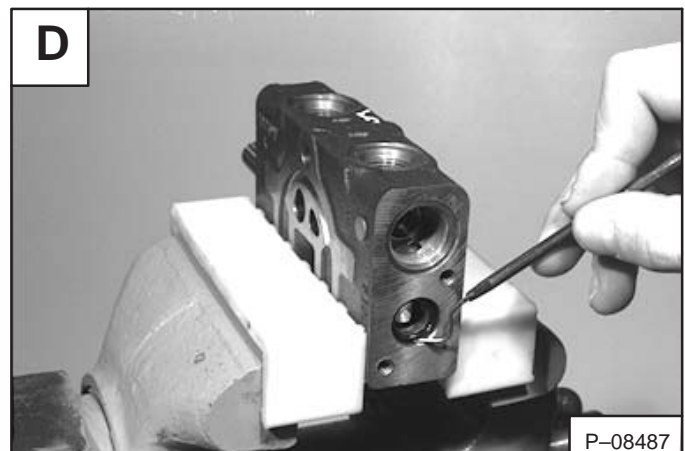
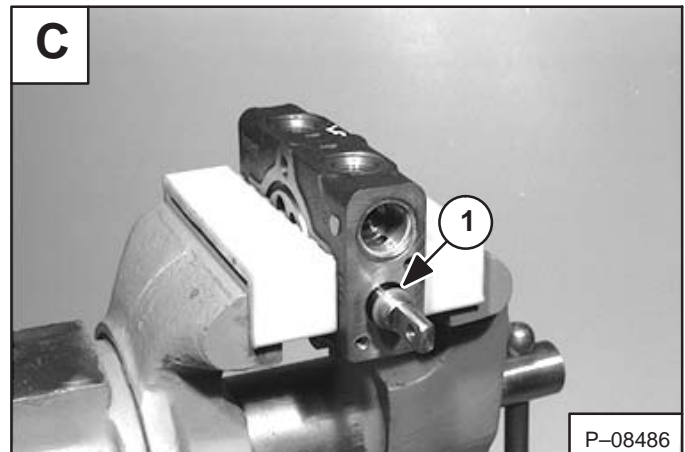
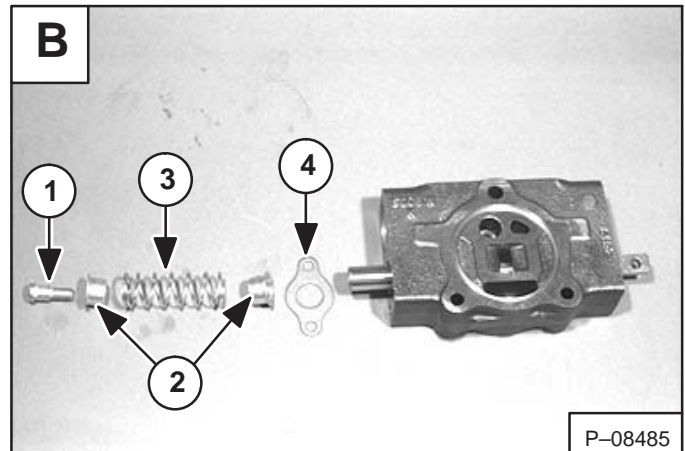
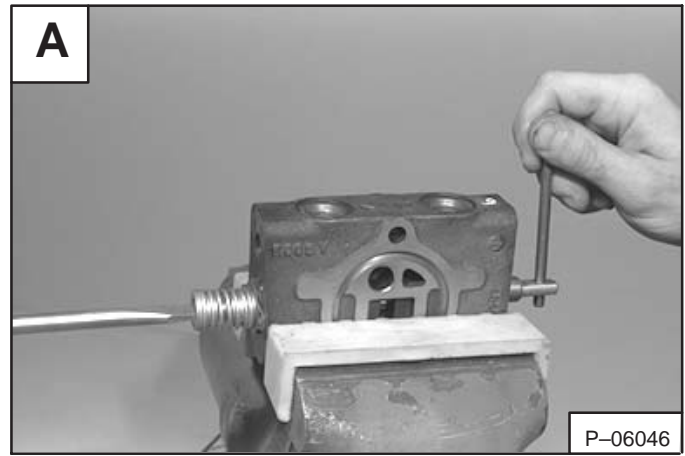

ACCUMULATOR (Cont'd)

Assembly (S/N 514013001 – 514017331
& 516611001 – 516611918) (Cont'd)

Install the accumulator (Item 1) [A] on the valve body.

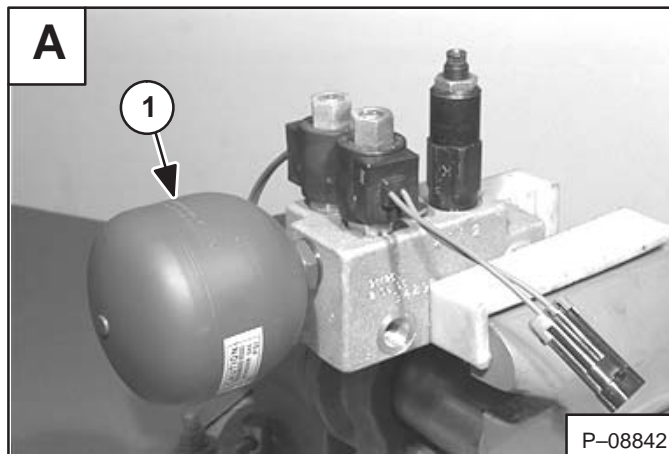

BUILD UP VALVE

Description

The build up valve provides hydraulic pressure to the joysticks when the engine is at low idle.

Removal And Installation

IMPORTANT

When repairing hydrostatic and hydraulic systems, clean the work area before disassembly and keep all parts clean. Always use caps and plugs on hoses, tubelines and ports to keep dirt out. Dirt can quickly damage the system.

I-2003-0888

Cut and remove the tie strap (Item 1) [A].

Remove the tubelines (Item 2) [A]. Remove the valve.

Disassembly And Assembly

Clamp the valve in a vise with padded jaws.

Remove the valve (Item 1) [B].

Remove the O-rings (Item 1) [C] and back up ring (Item 2) [C].

Clean all parts in solvent and dry with compressed air.

Apply oil to and install new O-rings (Item 1) [C] and back-up ring (Item 2) [C].

Install the valve (Item 1) [B] in the valve body.

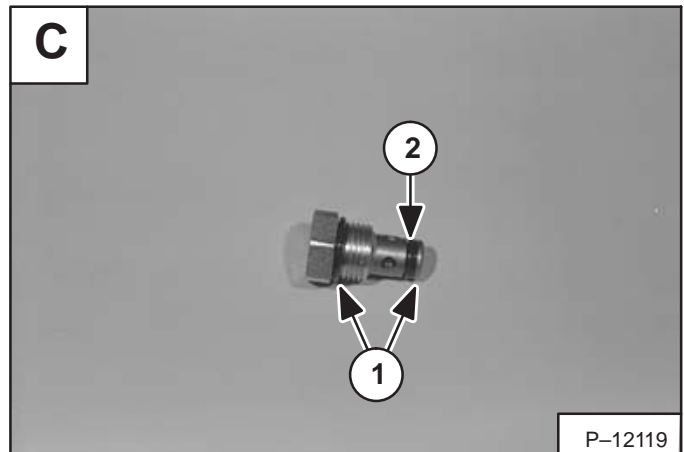
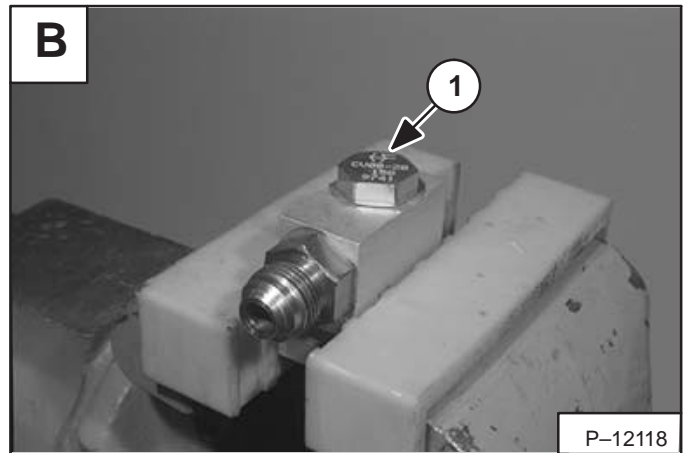
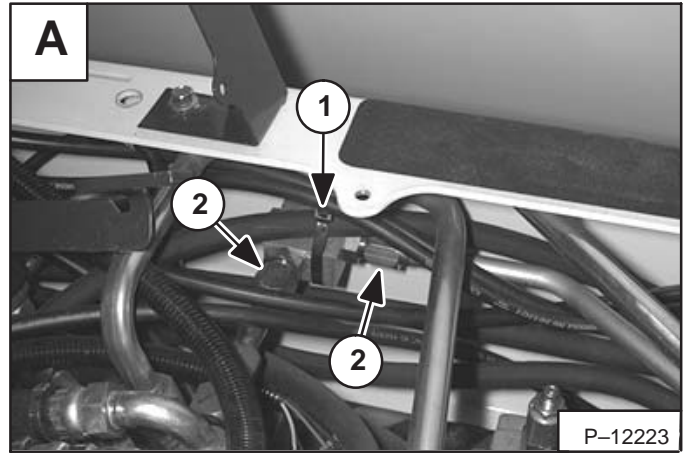

ARM CYLINDER (Cont'd)

Parts Identification

- 1. Seal (if equipped)
- 2. Bushing (if equipped)
- 3. Rod
- 4. Head
- 5. O-ring
- 6. Piston
- 7. Nut
- 8. Housing

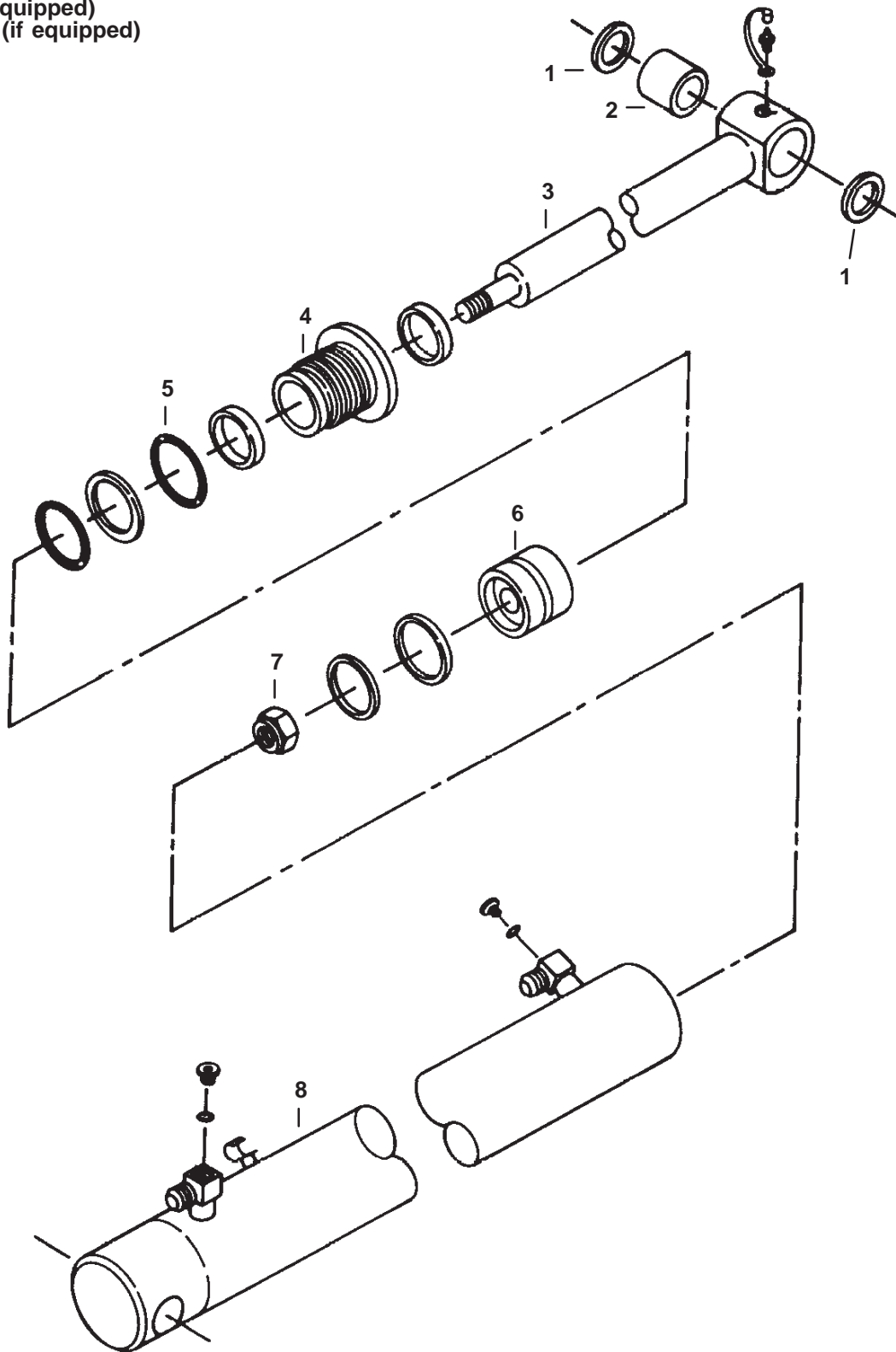

C-03283

HYDRAULIC CYLINDER (Cont'd)

Assembly (Cont'd)

Install the O-ring (Item 1) **[A]** onto the head.

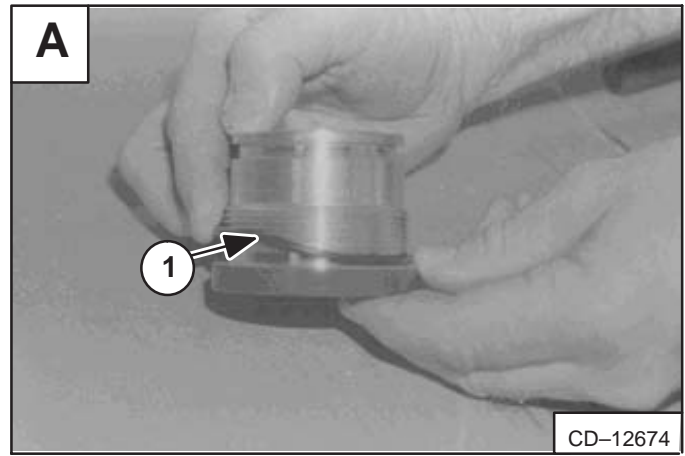

Install the back-up washer (Item 1) **[B]** and O-ring (Item 2) **[B]** onto the head.

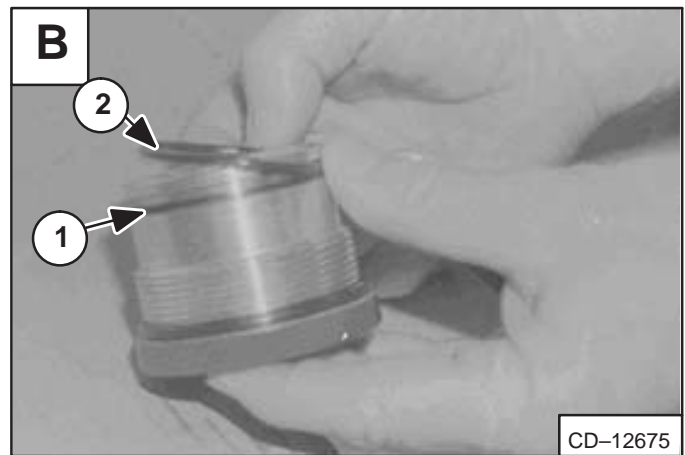

Apply grease to the inside of the head and to the lips of the seals.

Inspect the beveled edge of the rod for nicks or sharp edges **[C]**. Remove these with a file prior to installing the gland on the rod or damage to the seals may occur.

Install the head on the rod **[C]**.

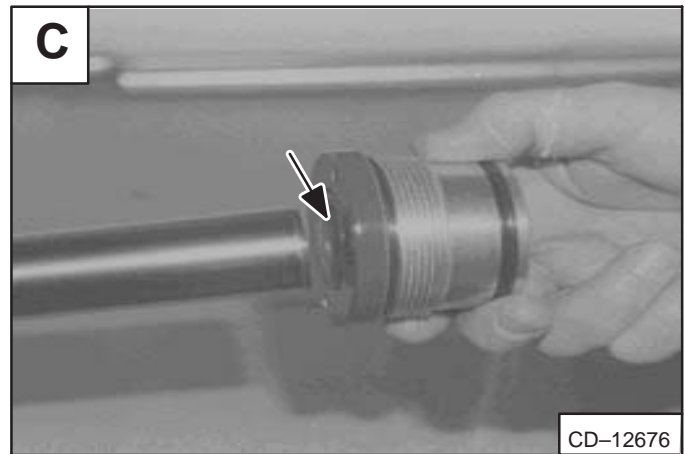

Install the piston on the rod **[D]**.

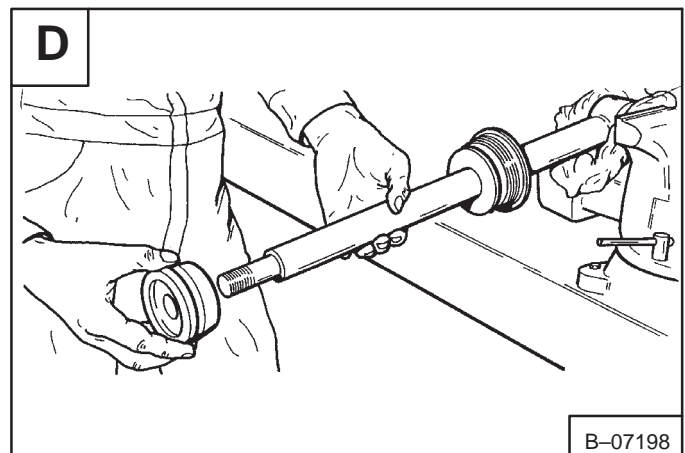

RIGHT CONSOLE (Cont'd)

Removal And Installation (Cont'd)

Remove the joystick control lever hose (Item 1) **[A]** from the accumulator and the joystick control lever hose (Item 2) **[A]** from the control valve (bucket section).

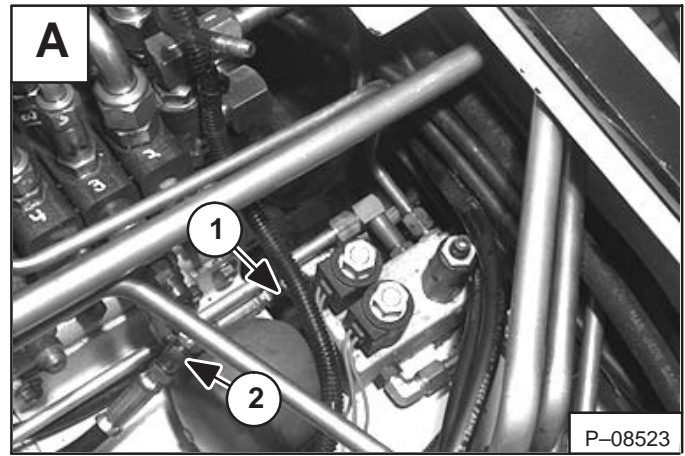

Remove the joystick control lever hose (Item 1) **[B]** from the control valve (bucket section).

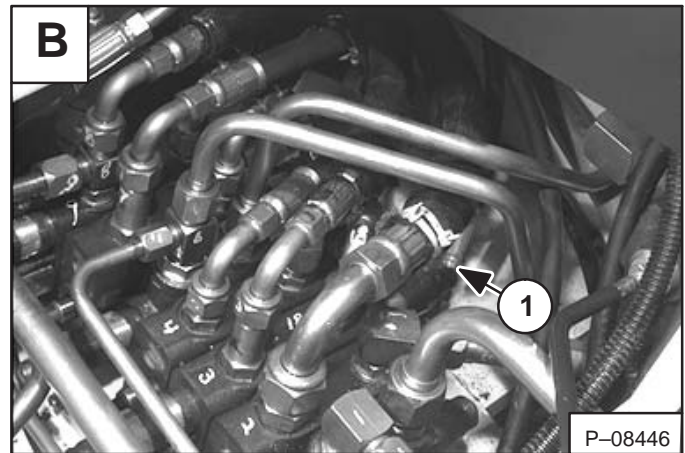

Remove the four bolts (Item 1) **[C]** from the bottom of the right hand console and remove the console.

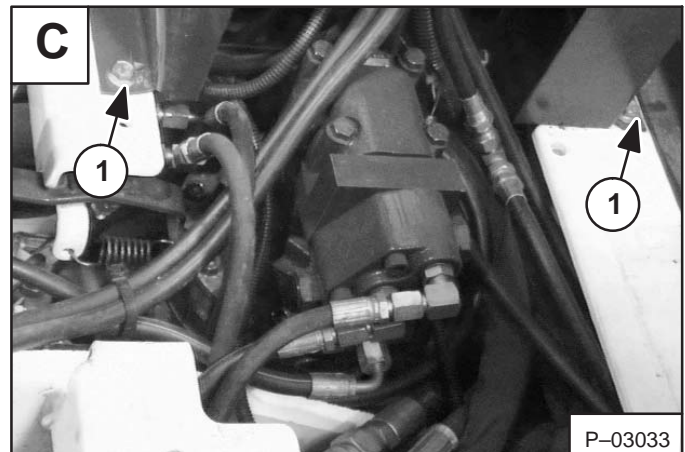

RIGHT CONSOLE (325 S/N 514014900 & Above) & (328 S/N 516611001 & Above)

Swing Lock Lever Removal And Installation

Remove the cotter pin (Item 1) [A].

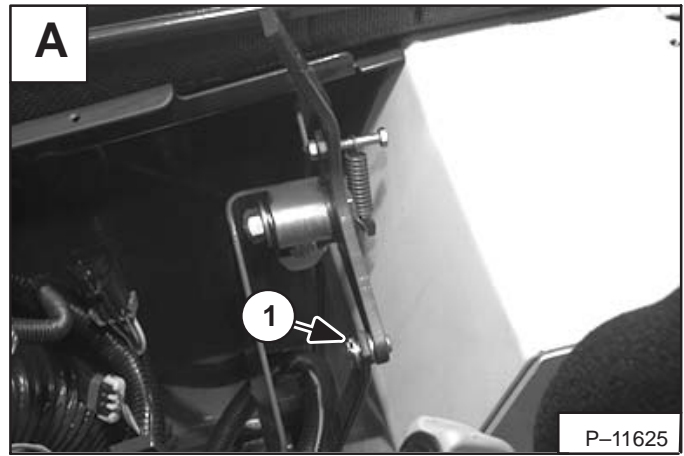

Remove the washer (Item 1) [B], wave washer (Item 2) [B], washer (Item 3) [B], and pin (Item 4) [B].

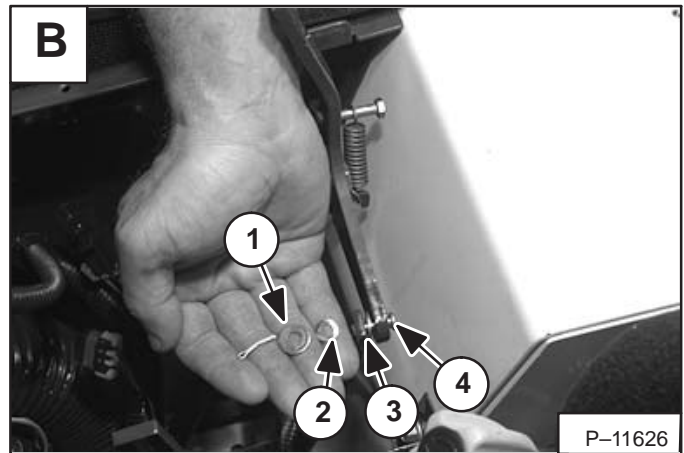

Remove the nut (Item 1) [C], bolt (Item 2) [C], and spring (Item 3) [C].

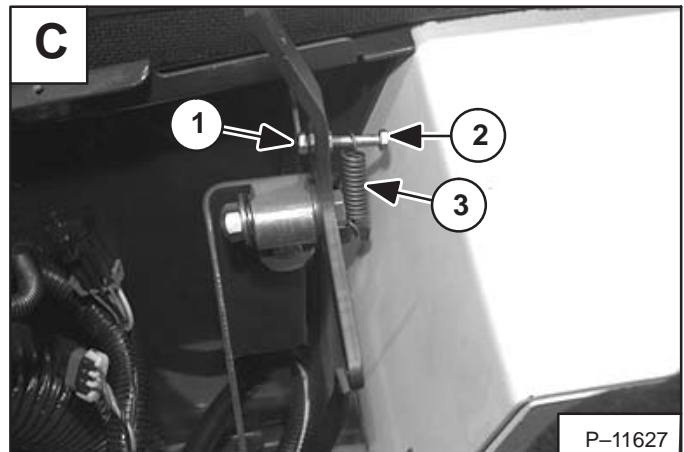

Remove the nut and bolt (Item 1) [D].



LEFT CONSOLE (Cont'd)

Control Lock Micro-switch Removal And Installation

Remove the left hand side cover. (See Page 4-1.)

Disconnect the micro-switch from the wire harness (Item 1) [A].

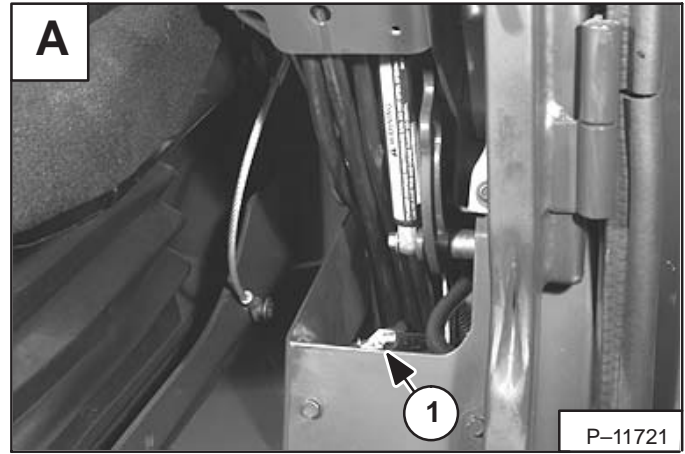

Remove the two bolts, nuts, and washers. Access the bolts through the holes (Item 1) [B] of the left console frame.

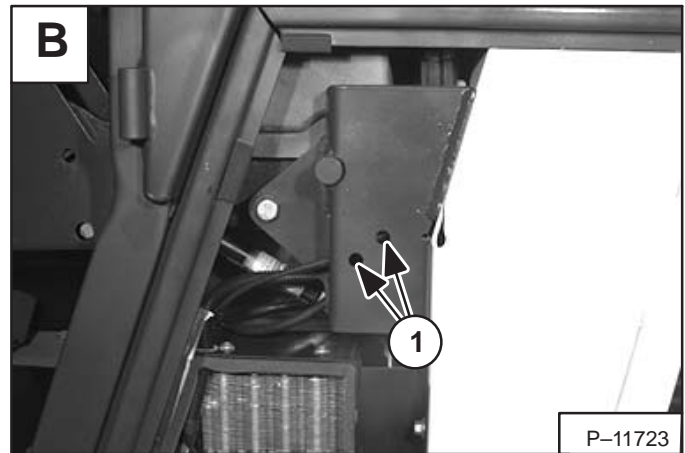

Installation: Position the Micro-switch as shown in [C].

NOTE: The console cover has been removed for photo purposes only.

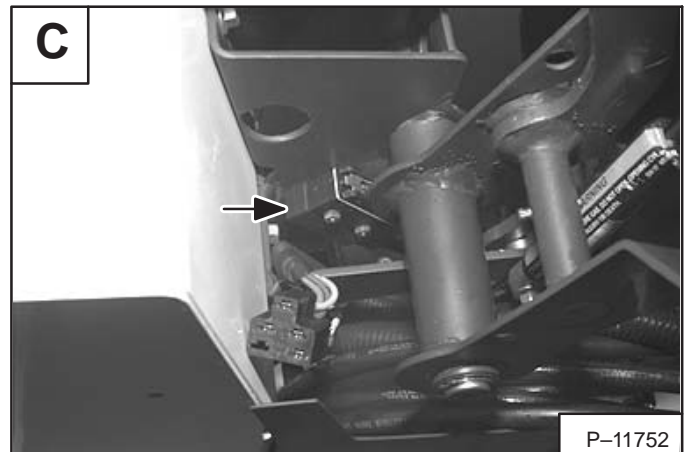

JOYSTICK (Cont'd)

Disassembly

Clamp the joystick in a vise with padded jaws.

Remove the screw (Item 1) **[A]** from the handle.

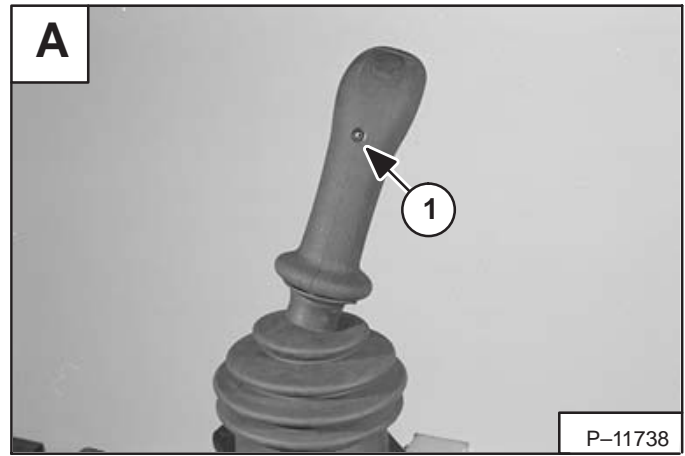

Slide the handle off the joystick **[B]**.

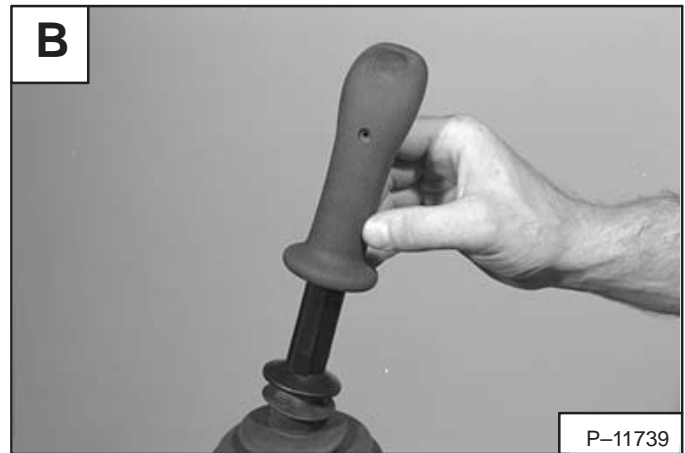

Remove the cap (Item 1) **[C]** from the horn button.

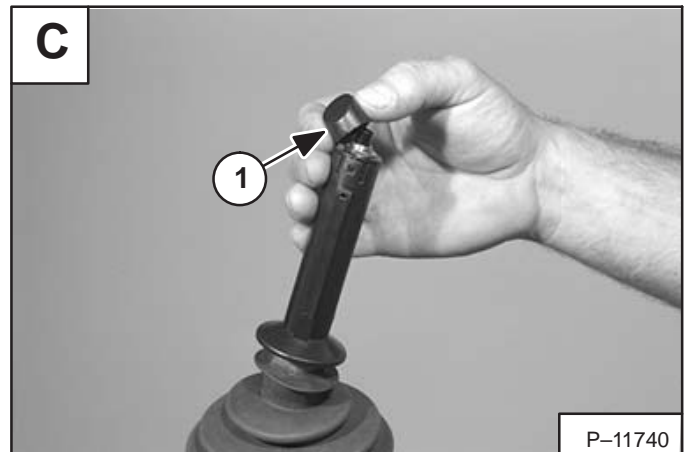

Remove the horn button (Item 1) **[D]** from the end of the handle.

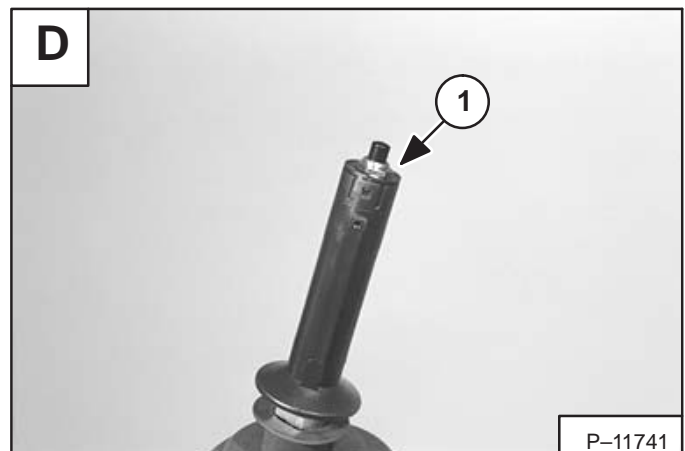

STEERING LEVERS AND PEDALS

Removal And Installation

NOTE: Excavator 325 S/N 514013001–514014899 is shown. The procedure is the same for 325 S/N 514014900 & Above & 328 S/N 516611001 & Above.

Remove the floor mat. (See Page 4–1.)

Remove the floor plate. (See Page 4–1.)

Remove the three cotter pins and the three clevis pins (Item 1) [A].

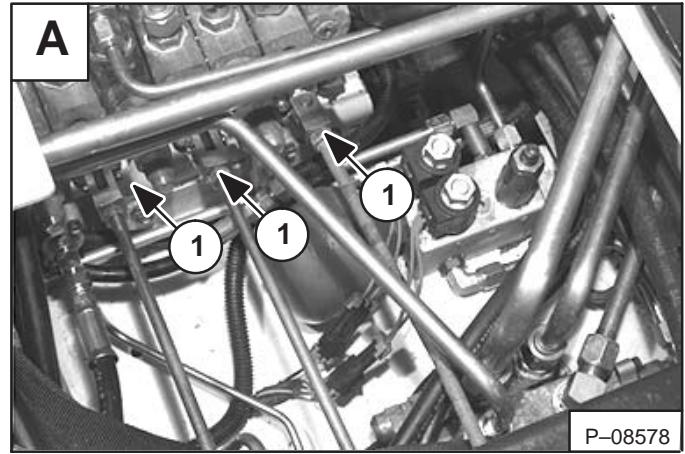

Remove the mounting bolts from the front floor panel [B].

Remove the boom swing linkage from the right pedal.



Lift the steering levers and floor plate from the machine [C].



CLICK HERE TO **DOWNLOAD** THE COMPLETE MANUAL

- Thank you very much for reading the preview of the manual.
- You can download the complete manual from: www.heydownloads.com by clicking the link below



- Please note: If there is no response to CLICKING the link, please download this PDF first and then click on it.

CLICK HERE TO **DOWNLOAD** THE COMPLETE MANUAL

LEFT SIDE COVER

Removal And Installation (325 S/N 514013001–514014899)

Remove the five bolts [A] from the side cover.

Remove the cover.

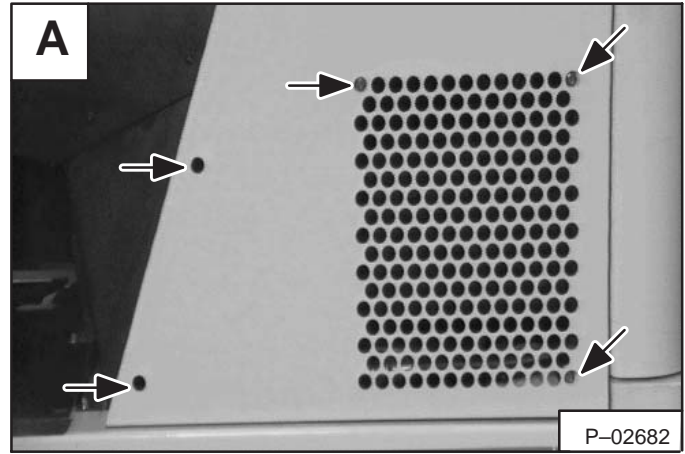

Removal And Installation (325 S/N 514014900 & Above) & (328 S/N 516611001 & Above)

Using the start key, unlock and remove the left side cover [B].



RIGHT SIDE COVER

Removal And Installation

Using the start key, unlock and remove the right side cover.



BOOM BUSHING

Removal And Installation

Remove the boom. (See Page 4-17.)

Remove the dust seals from both sides of the boom.

Remove the bushings from both sides of the boom.

Install the new bushings in the boom.

If the boom has the stepped bore, install the bushings flush with the pin boss **[A]** (both sides).

If the boom has the through bore, install the bushings until they are seated 0.197 inch (5 mm) in the pin boss **[B]** (both sides).

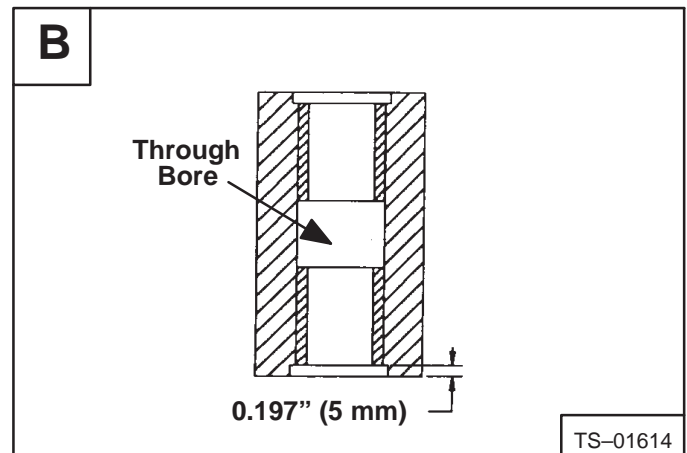
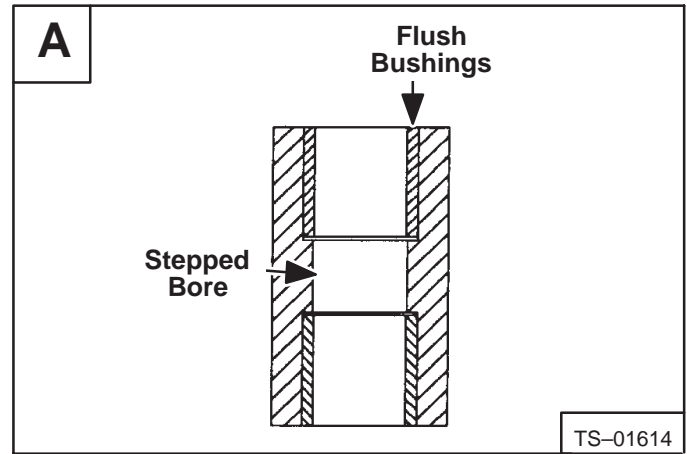

SWING MOTOR (Cont'd)

Assembly (Cont'd)

Install the two new small O-rings (Item 1) **[A]** on the geroler (both sides).

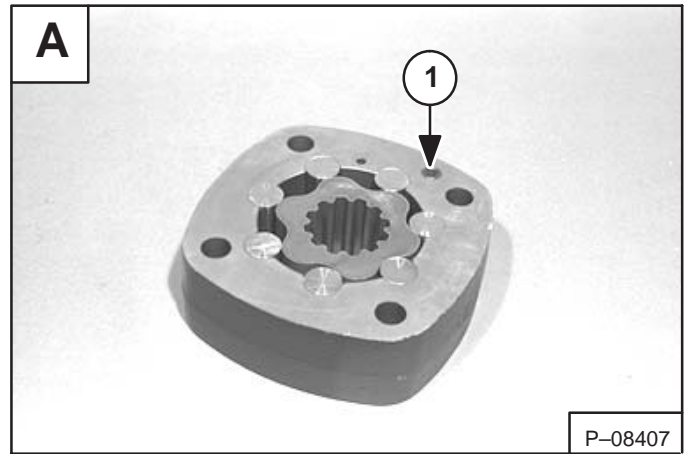

Timing the hydraulic motor.

The timing parts include:

1. Geroler
2. Valve drive
3. Valve plate
4. Valve

Locate the largest opening in the geroler, and mark the location on the outside edge of the geroler (Item 1) **[B]**. Align the case drain hole (Item 2) **[B]** and the pressure relief hole (Item 3) **[B]** in the geroler with the case drain hole and pressure relief hole in the bearing housing. Install the geroler on the bearing housing.

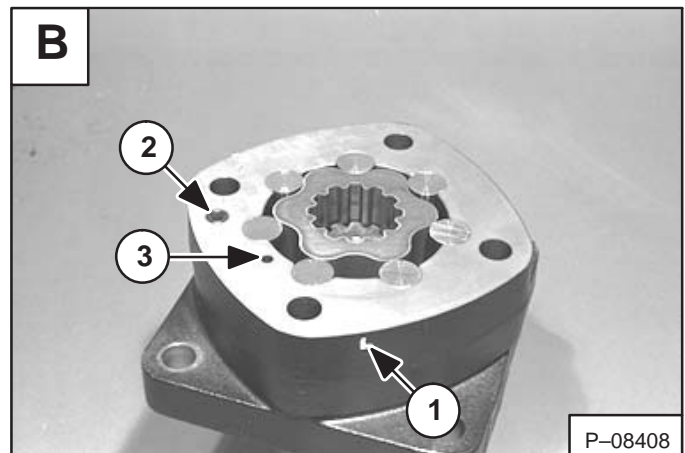

Install the valve drive (Item 1) **[C]** in the geroler.

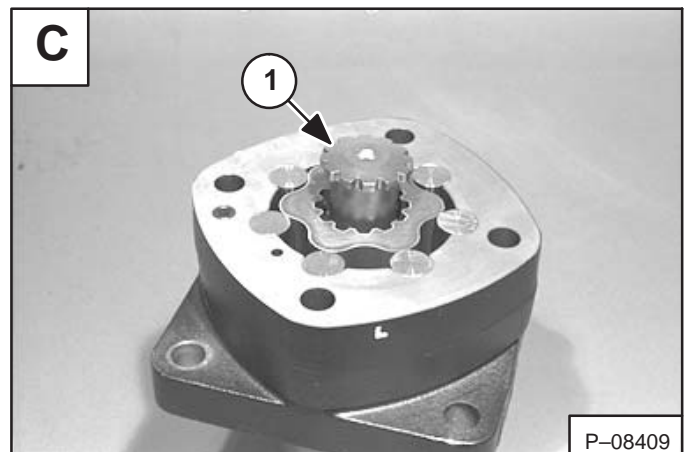

Install the large O-ring (Item 1) **[D]** on the valve plate (Item 2) **[D]**.

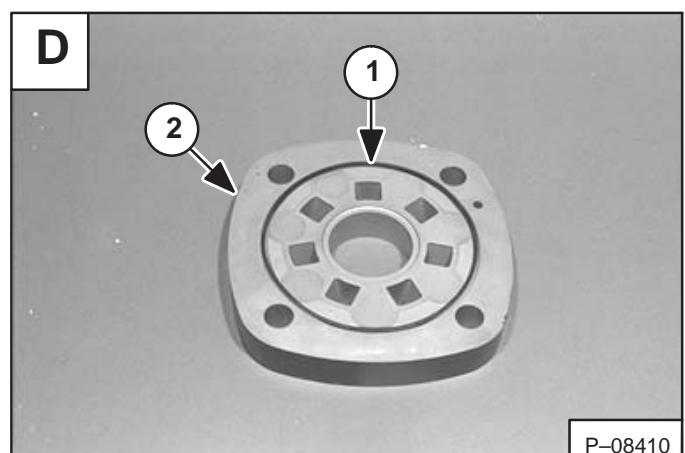

SWING MOTOR DRIVE CARRIER (Cont'd)

Assembly (Cont'd)

Oil and install a new O-ring inside the spacer **[A]**.



Press the spacer (Item 1) **[B]** and a new bearing (Item 2) **[B]** on to the drive shaft.

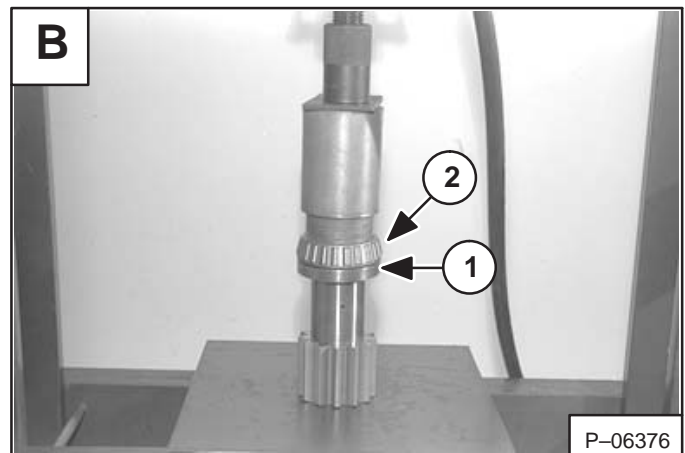

Install the drive shaft with the spacer and the new bearing installed, through the bottom of the carrier.

Press a new bearing on the top of the drive shaft **[C]**.

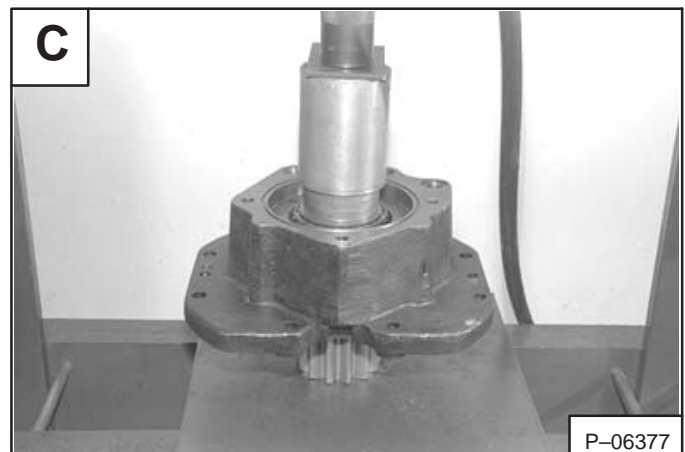

Install the washer (Item 1) **[D]** and the snap ring (Item 2) **[D]** on the drive shaft.

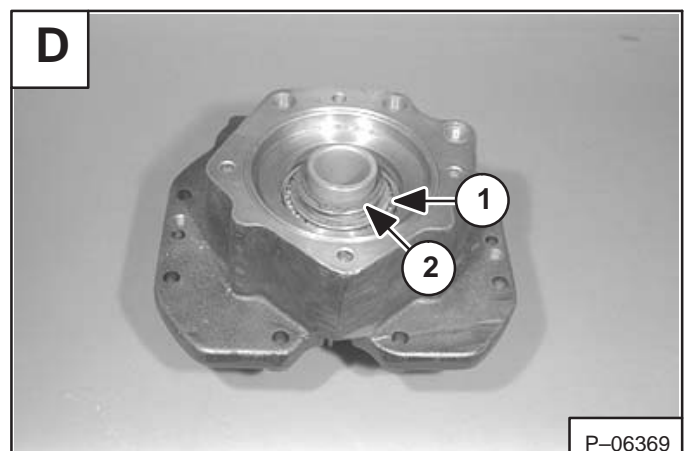

CENTER SWIVEL JOINT (Cont'd)

Parts Identification

SWIVEL JOINT

- 1. Bolt
- 2. Rotor
- 3. Plug
- 4. Seal
- 5. Seal
- 6. Seal
- 7. Body
- 8. O-Ring
- 9. Cover
- 10. Bolt

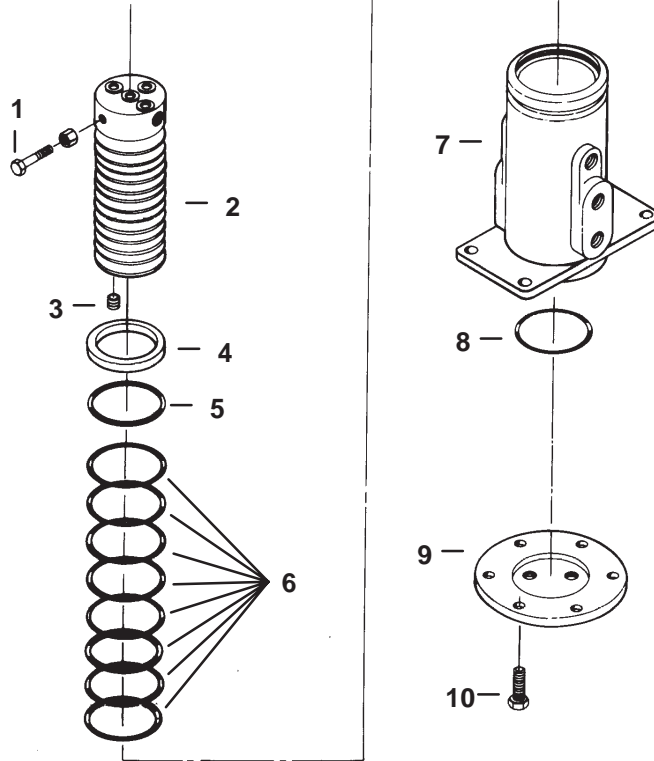

D-02250

CAB (Cont'd)

Heater Removal And Installation (Cont'd)

Mark the locations of the two heater hoses (inlet & outlet) for correct installation.

Loosen the two heater hose clamps and remove the heater hoses from the heater core [A].

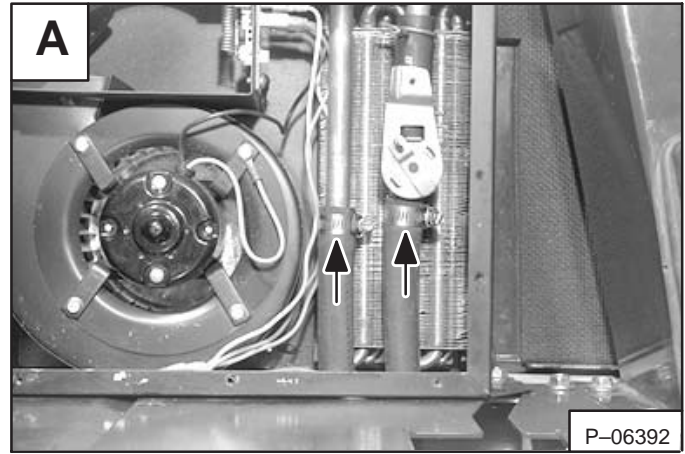

Remove the two bolts from the base of the heater [B].

Remove the heater assembly.

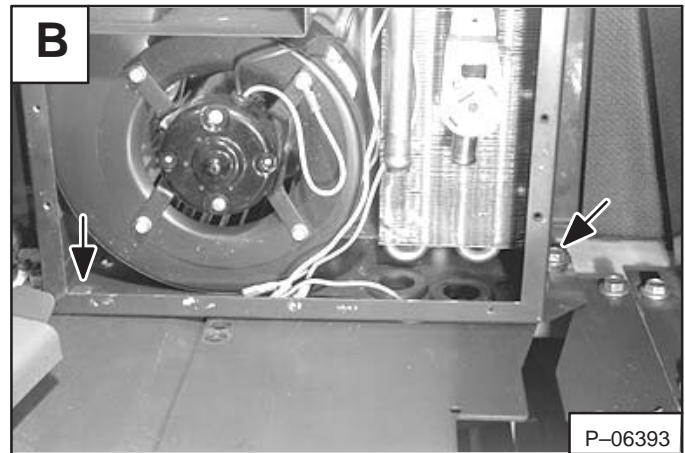

Heater Removal And Installation (325 S/N 514014900 & Above) & (328 S/N 516611001 & Above)

Remove the seat and seat mount. (See Page 4-3, 4-4.)

Remove the floor mat and floor plate. (See Page 4-5.)

Remove the left hand side cover. (See Page 4-8.)

Remove the heater air filter. (See Page 1-1.)

Drain the radiator. (See Page 7-1.)

Remove the auxiliary flow control knob mount bolts (Item 1) [C].

Remove the auxiliary flow control knob.

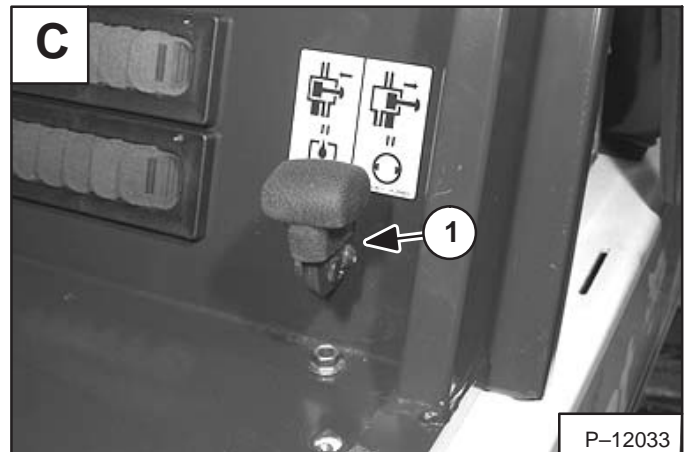

Remove the bolt (Item 1) [D].

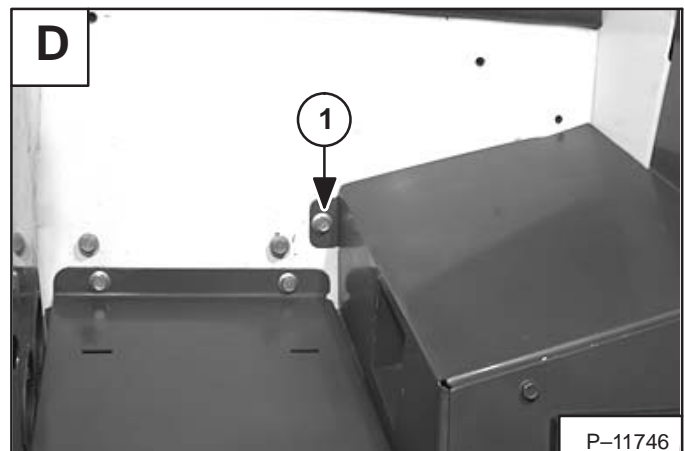

CAB (Cont'd)

Right Hand Window Assembly Removal And Installation

To remove the right hand window assembly, remove the two pieces of window (See Page 4-67). Carefully pry out the window frame from the cab assembly.

NOTE: If the window frame is to be reused, use care to remove the frame. The window frame is aluminum and can easily be damaged.

To install the window frame, clean the cab frame opening of any dust, dirt, grease or existing urethane window sealant.

Put a bead of urethane window sealant (P/N 6654148) on the window frame assembly as shown [A].

Install the window assembly into the opening and press into position.

Let the sealant set-up (per the recommendation on the sealant instructions on the tube) before moving the excavator.

Rear Window Removal And Installation

Remove the four clamps [B].

Hold the window in position while cutting the abrasive.

Insert the cut wire through the adhesive at the corner of the window. Pull the wire around the window perimeter to cut the adhesive [C].

Installation: Install the adhesive tape to the outer perimeter of the window. Put the window into the window opening and press the window into position.

Install the four window retaining clamps.

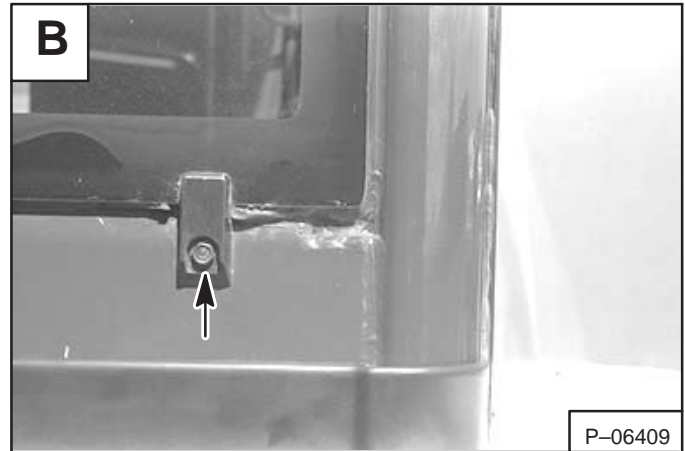
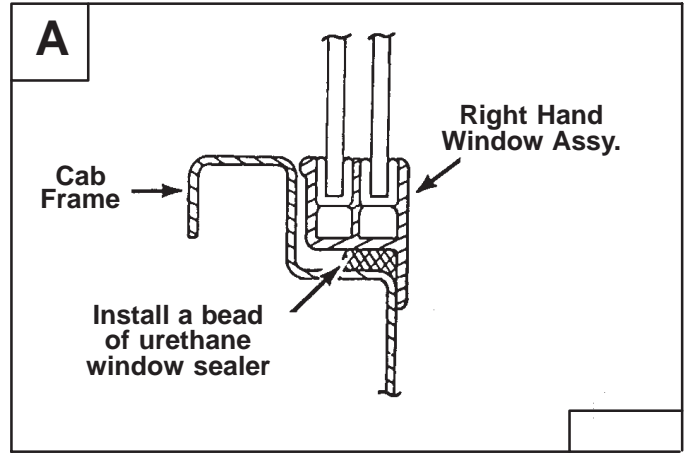

TRACK (Cont'd)

Rubber Track Removal And Installation (Cont'd)

Start the engine.

Slowly turn the track in the forward direction.

Insert a steel rod or pipe (Approximately 1.250 inch [30 mm] diameter) between the track and the idler wheel **[A]**.

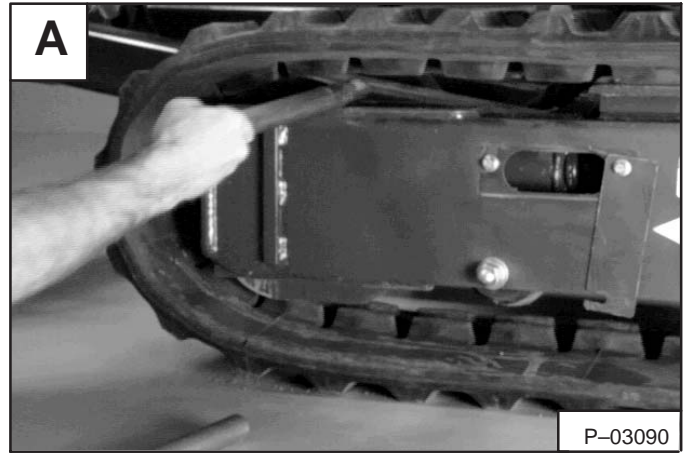

Insert a second steel rod or pipe, at a distance of two lugs, between the track and the idler wheel **[B]**. Continue to turn the track until the first pipe contacts the track frame.

Stop the engine.

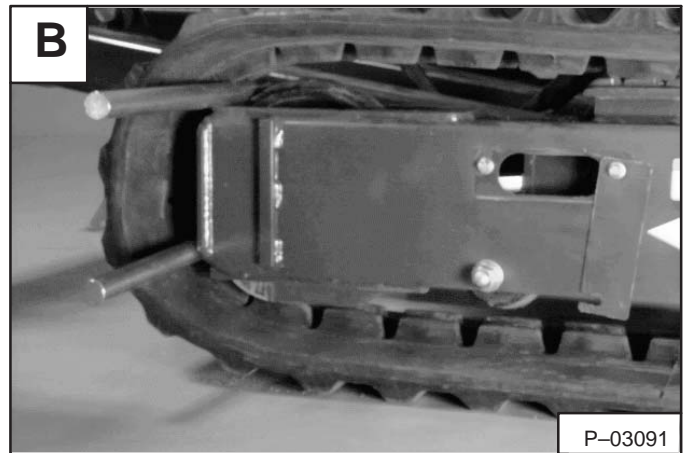

Insert a pry bar between the track and the idler wheel and pry outwards on the track until the track slides off of the idler wheel **[C]**.

Remove the track.

To install the rubber track:

Position the track over the drive sprocket lugs.

Position the front of the track on to the front idler wheel.

See Page 5-4 for adding grease to the grease spring and for checking track sag.

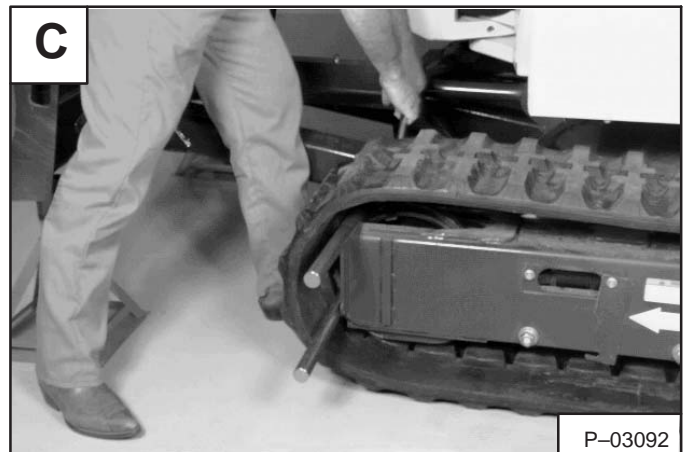

TRACK IDLER (Cont'd)

Assembly (Cont'd)

Turn the idler assembly over.

Using the driver tool, install the other bearing, with the numbered side upward, into the idler **[A]**.



Install the snap ring **[B]**.



Using a dial indicator, check the endplay of the shaft **[C]**.

If the endplay is greater than 0.030 inch (0,76 mm) then the bearing must be shimmed.

Cut a shim from the necessary thickness shim stock and install the shim between the bearing and the shoulder on the shaft.

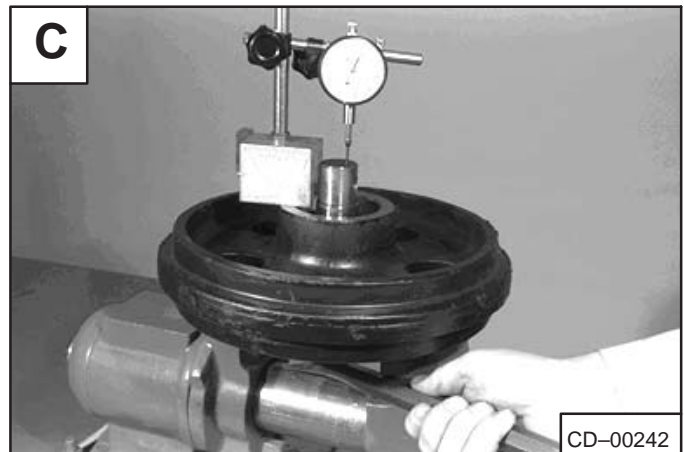

Separate the inner and outer halves of the seal.

Apply grease to the grooves on the outer part of a new seal **[D]**.

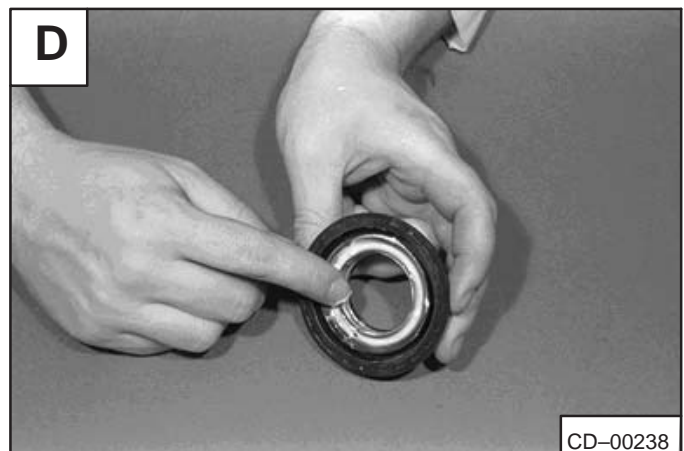

TRAVEL MOTOR

Removal And Installation

Lift and block the side of the track frame where the final drive will be removed.

Release the track tension and remove the track. (See Page 5-7.)

Remove the bolts (Item 1) [A] from the track frame cover.

Installation: Tighten the bolts to 20–25 ft.-lbs. (27–34 Nm) torque.

Remove the cover.

IMPORTANT

When repairing hydrostatic and hydraulic systems, clean the work area before disassembly and keep all parts clean. Always use caps and plugs on hoses, tubelines and ports to keep dirt out. Dirt can quickly damage the system.

I-2003-0888

Mark the hoses for correct installation.

Disconnect the three hoses (Item 1) [B] from the drive motor.

Loosen and remove the nine final drive mounting bolts (Item 1) [C].

Installation: Apply thread adhesive (LOCTITE 242) on the bolts and tighten to 80 ft.-lbs. (108 Nm) torque.

Remove the motor assembly from the track frame [D].

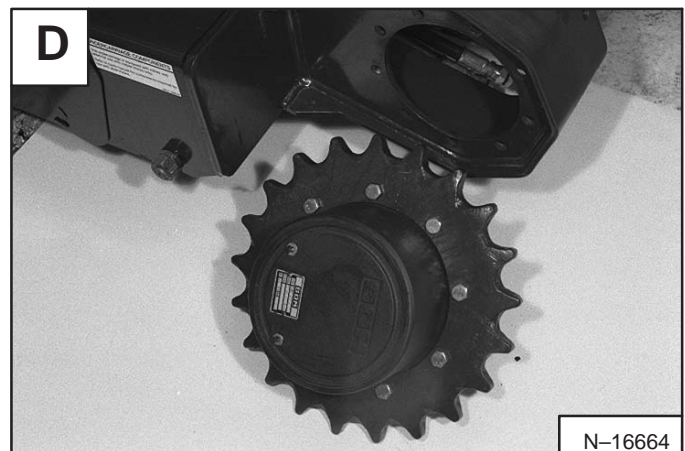
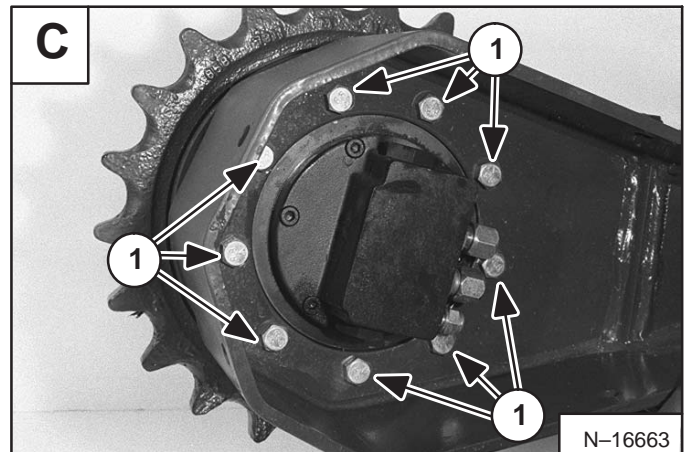
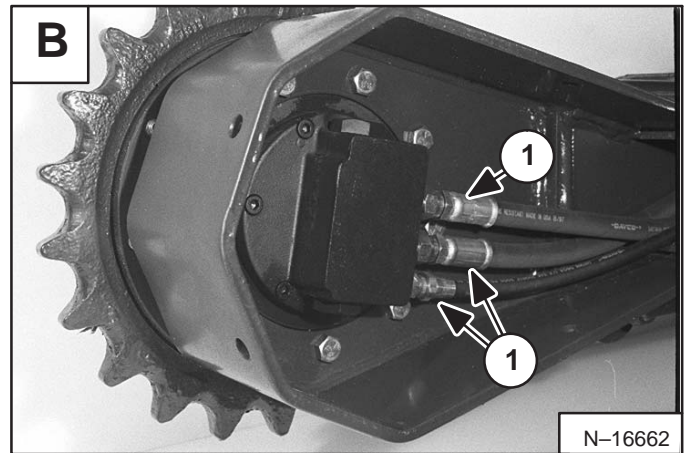
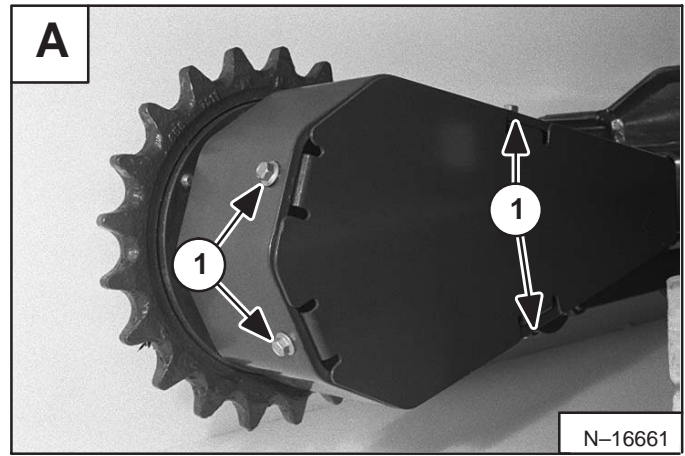

TRAVEL MOTOR (Cont'd)

Assembly (Cont'd)

Invert the hub and install the alignment pin (Item 1) [A] and swash plate (Item 2) [A].

Install the two alignment pins (Item 3) [A] in the motor hub.

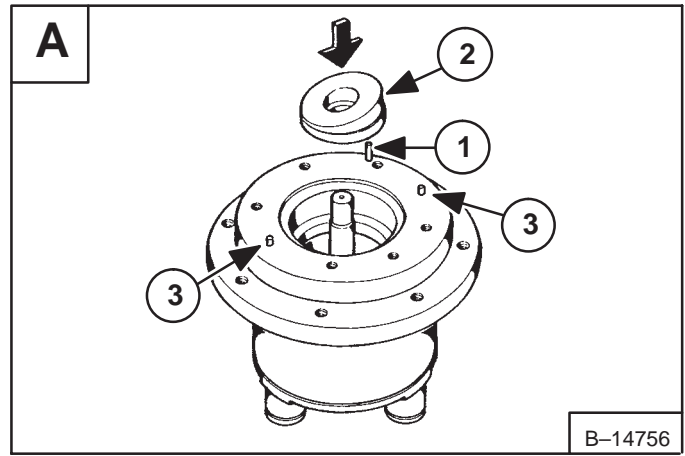

Apply oil to the piston faces and install the rotating block (Item 1) [B] in the motor hub.

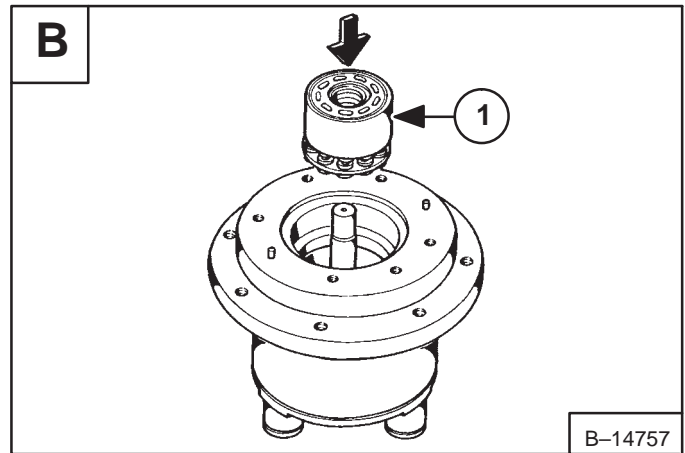

Press the bearing (Item 1) [C] & [D] in the motor cover.

The bearing (Item 1) [C] must extend from the face of the motor cover 0.098–0.110 inch (2,5–2,8 mm).

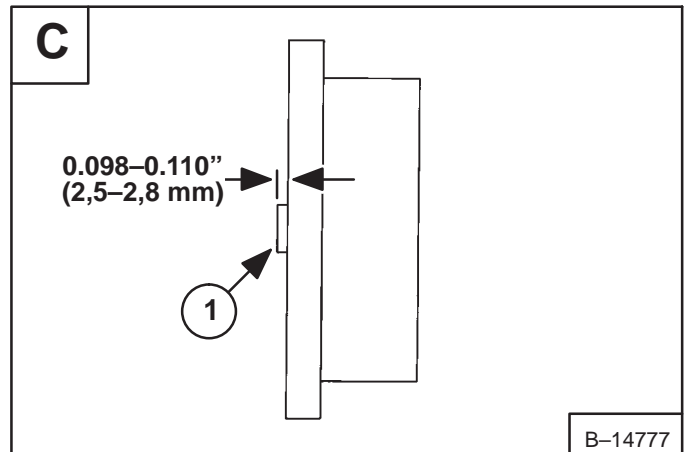

Apply oil to and install the O-ring (Item 2) [D] on the motor cover.

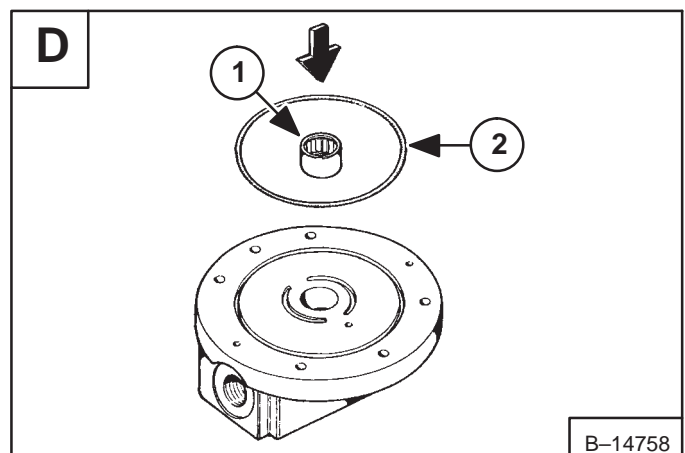

TRACK DAMAGE IDENTIFICATION (Cont'd)

Separation Of Embedded Metals

Damage:

Extraordinary outer forces applied to embedded metals cause their separation from the rubber track's body [A].

Replacement:

Even a partial separation of embedded metals requires replacement of the track.

Causes of the damage:

Embedded metals are adhered between the steel cords and the rubber body. The following cases generate external forces greater than the adhesion strength, causing separation of the embedded metals:

When the idler continually rides on the projections of embedded metals, the embedded metals will eventually peel off [B].

When a rubber track is detracted, it becomes stuck between the guide or the undercarriage frame, causing the separation of embedded metals [C].

Abnormally worn sprockets as shown will pull embedded metals out [D].

Prevention:

Similar to the prevention against the cutting of the steel cords:

Recommended track tension should be periodically checked. (See Page 5-4.)

Quick turns on bumpy and rocky fields should be avoided.

If abnormal wear of sprockets is observed, they should be immediately replaced.

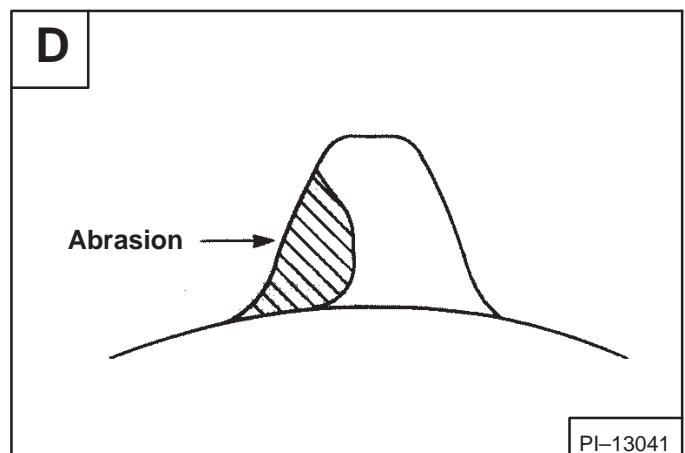
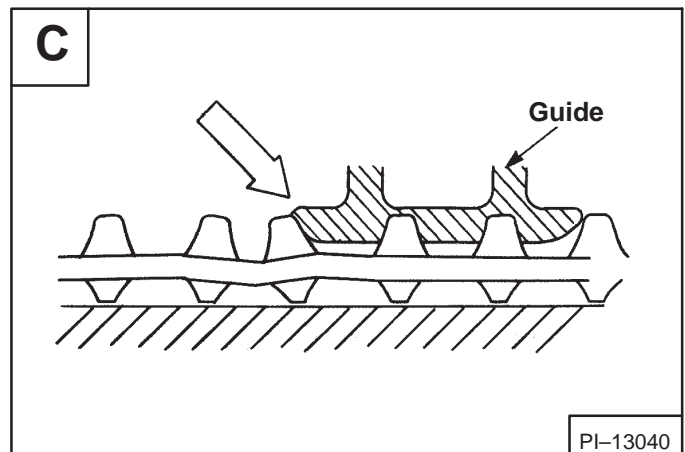
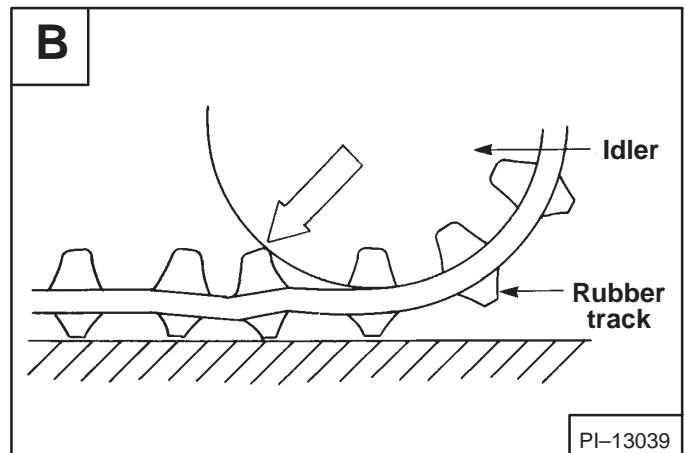
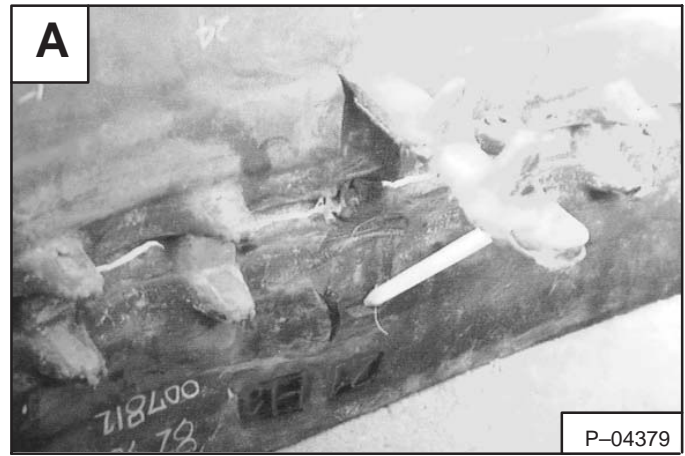

ALTERNATOR

Belt Adjustment

Stop the engine. Open the engine cover.

The belt should deflect about 0.500 inch (13 mm) when pressed between the water pump pulley and crankshaft pulley with approximately 13 lbs. (58 N) force [A].

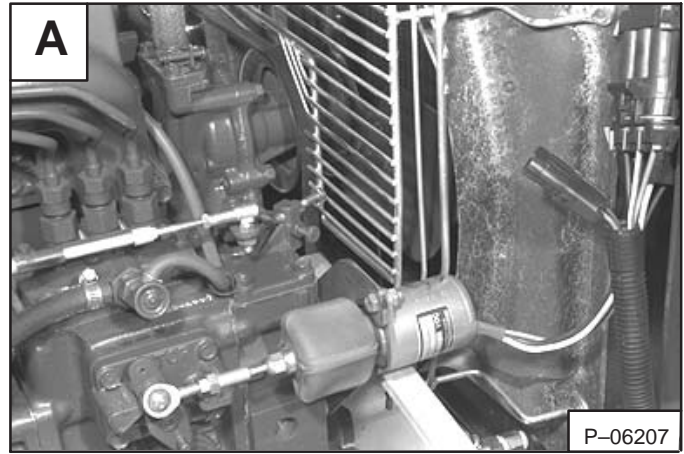

If the tension is not correct, remove the seat and seat mount. (See Page 4-1.)

Loosen the adjustment bolt (Item 1) [B].

Loosen the mount bolt (Item 2) [B].

Move the alternator until the belt tension is correct. Tighten the adjustment bolt and mounting bolt.

Replace the belt if it has stretched or there are cracks in the belt. Check the pulley grooves, make sure the belt is not in contact with the bottom of the grooves in the pulleys.

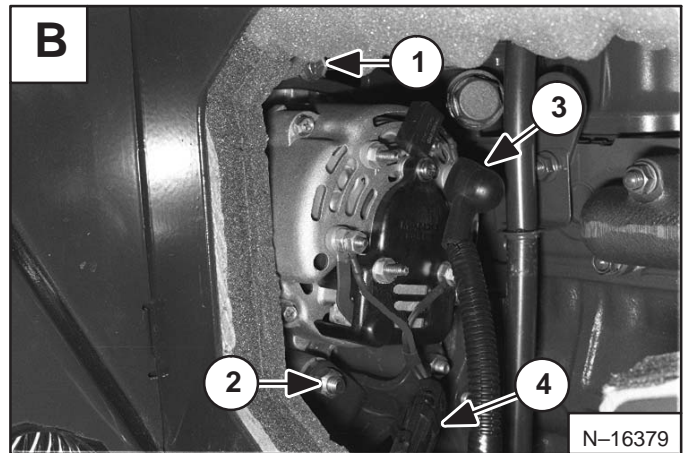

Removal And Installation

Disconnect the negative (-) battery cable. (See Page 6-6.)

Remove the seat and seat mount (See Page 4-1.) for access to the alternator bolts and wiring from the operator area.

Remove the wire (Item 3) [B] going to the battery terminal of the alternator.

Disconnect the harness connector (Item 4) [B] from the alternator.

Remove the adjusting bolt (Item 1) [B].

Remove the mounting bolt (Item 2) [B].

Remove the alternator.

Installation: When installing a new alternator or after an alternator has been rebuilt, check that the wires are connected to the correct terminals.

The purple wire (Item 1) [C] connects to the L2 terminal.

The red wire (Item 2) [C] connects to the S terminal.

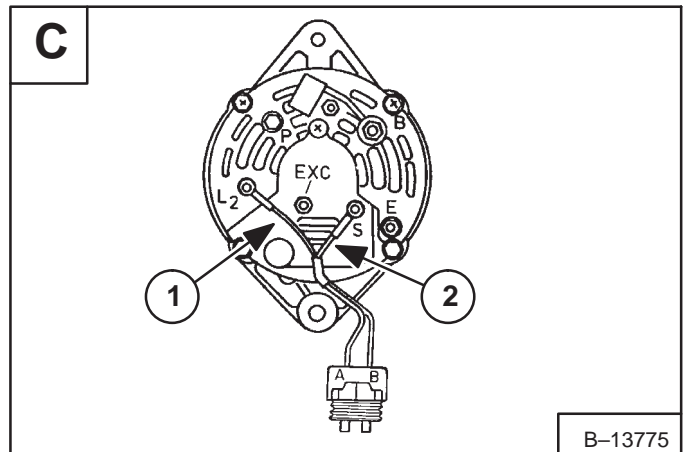

STARTER (Cont'd)

Parts Identification (325 S/N 514014900 & Above) & (328 S/N 516611001 & Above)

- 1. Screw
- 2. Bolt
- 3. Brush Cover
- 4. Brush Holder
- 5. Bearing
- 6. Armature
- 7. Bearing
- 8. O-ring
- 9. Frame
- 10. Bolt
- 11. Cover

- 12. Gasket
- 13. Switch
- 14. Nut
- 15. Nut
- 16. Housing
- 17. Idler Gear
- 18. Roller
- 19. Retainer
- 20. Spring
- 21. Ball
- 22. Pinion Shaft

- 23. Spring
- 24. Clutch
- 25. O-ring
- 26. O-ring
- 27. Washer
- 28. Bolt
- 29. Housing
- 30. Spring Seat
- 31. Spring
- 32. Pinion Gear
- 33. Collar
- 34. Snap Ring

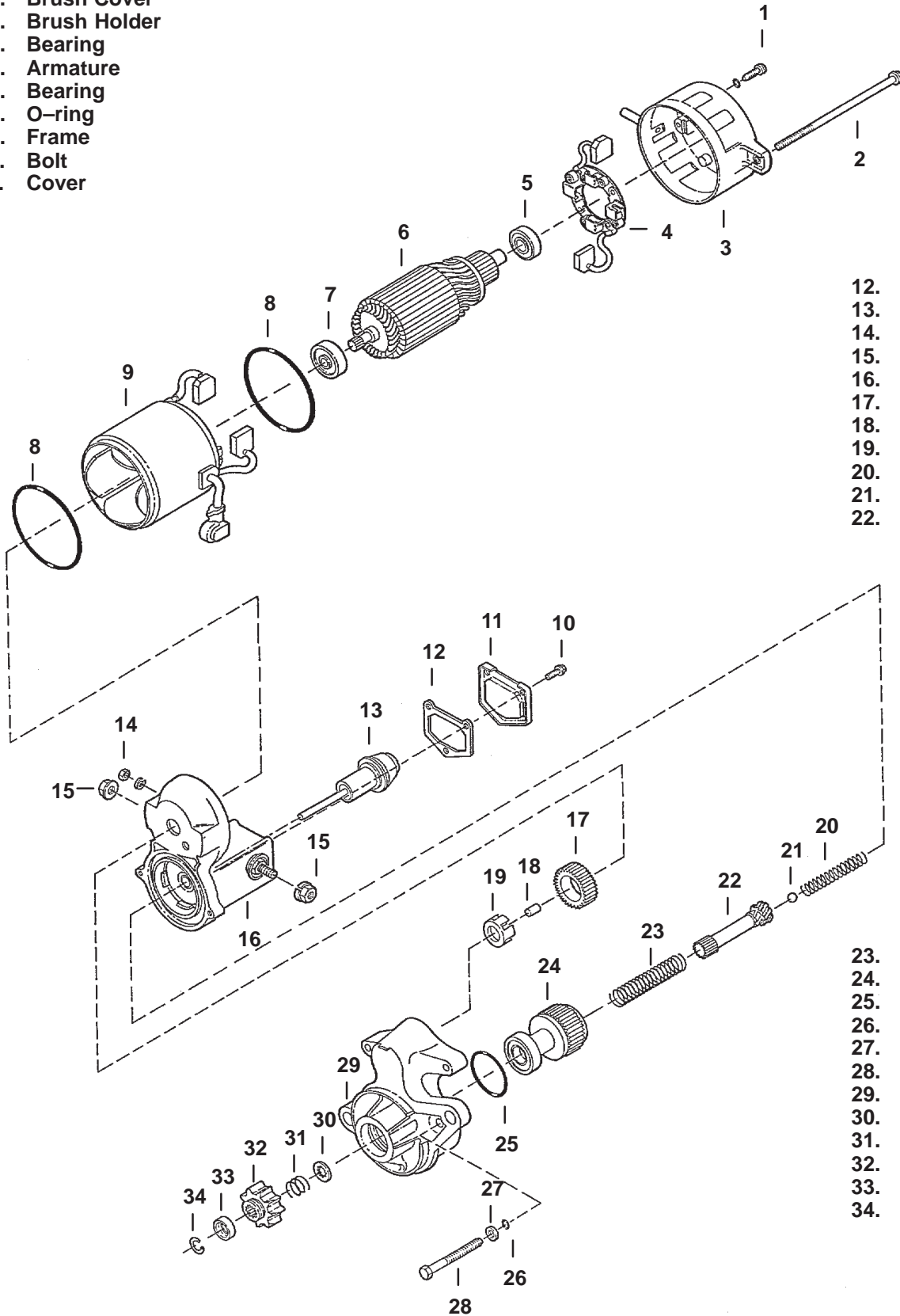

D-02396

STARTER (Cont'd)

Assembly (Cont'd)

Install the snap ring (Item 1) [A]. Pull the collar (Item 2) [A] over the snap ring.

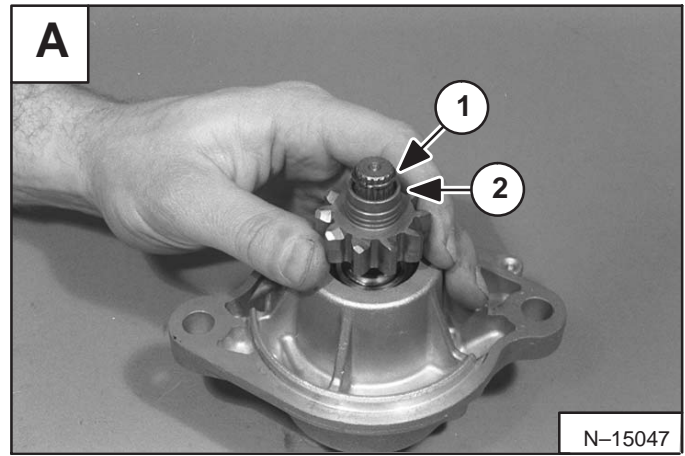

With the pinion shaft extended, extend and release the pinion (Item 1) [B]. The pinion must return to the fully retracted position.

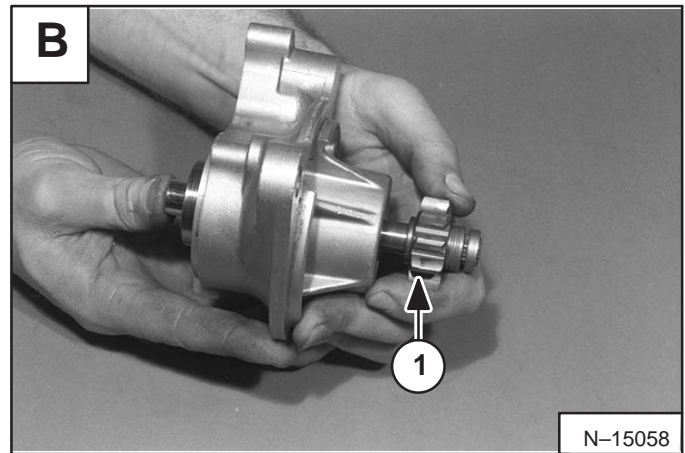

Install the rollers (Item 1) [C] in the retainer.

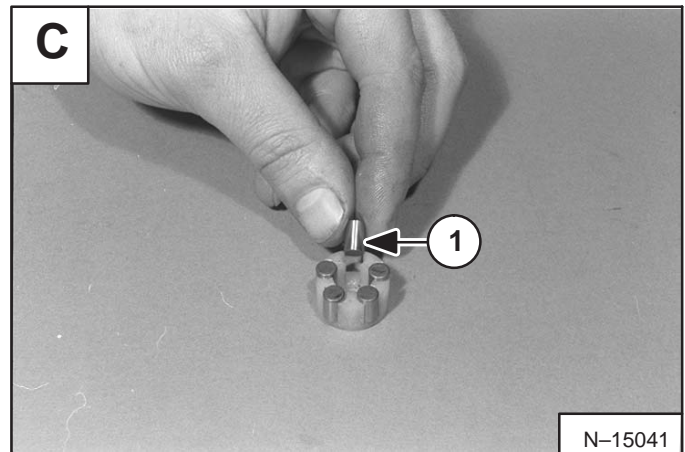

Install the roller/retainer assembly (Item 1) [D] on the starter housing.

Install the idler gear (Item 2) [D] over the roller/retainer assembly.

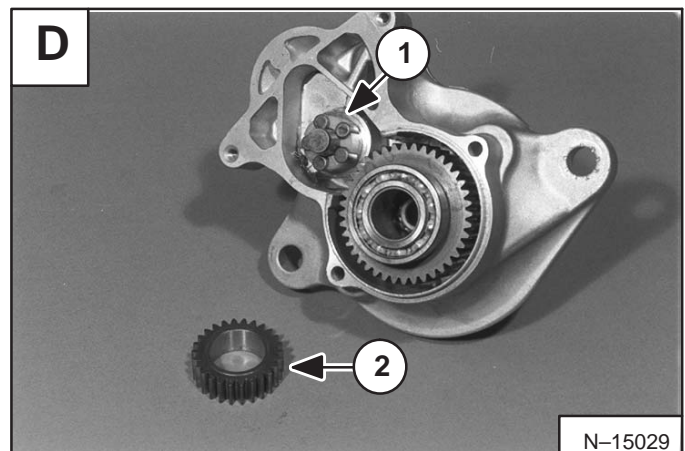

HORN

Removal And Installation

Access the horn through the right front side of the upperstructure.

Swing the boom to the left.

Disconnect the horn from the wire harness (Item 1) [A]

Remove the mount bolt (Item 2) [A] and remove the horn.

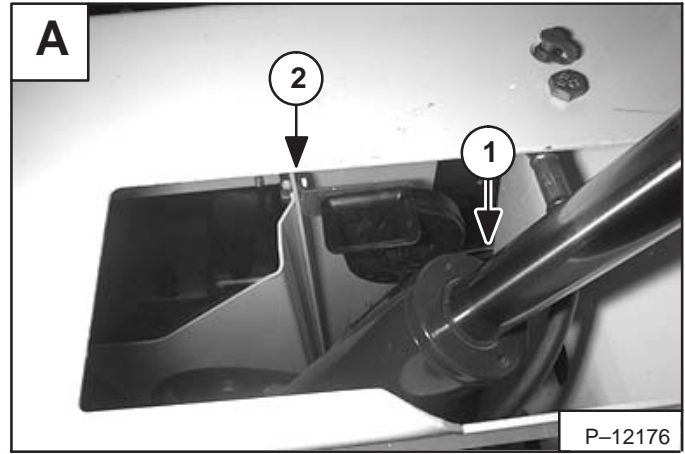

BUZZER

Removal And Installation

Remove the right console cover. (See Page 3-1.)

Remove the wire harness (Item 1) [B] from the buzzer.

Remove the bolt and nut (Item 2) [B] from the console. Remove the buzzer.

NOTE: The procedure is shown on excavator 325 S/N 514014900 & Above and 328 S/N 516611001 & Above. The procedure is the same for all excavators.

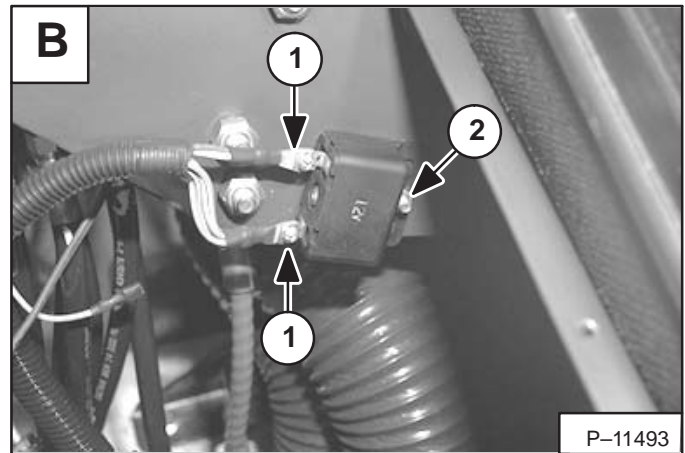

TWO SPEED SWITCH

Removal And Installation

Remove the floor mat. (See Page 4-1.)

Remove the floor plate. (See Page 4-1.)

Unplug the two speed switch from the wire harness (Item 1) [C] & [D].

Remove the two mounting nuts and bolts (Item 2) [C] & [D] from the floor plate.

Remove the two speed switch from the floor plate.

NOTE: The electric two speed switch is not serviceable. If the switch is not operating correctly, discard and replace with a new two speed switch.

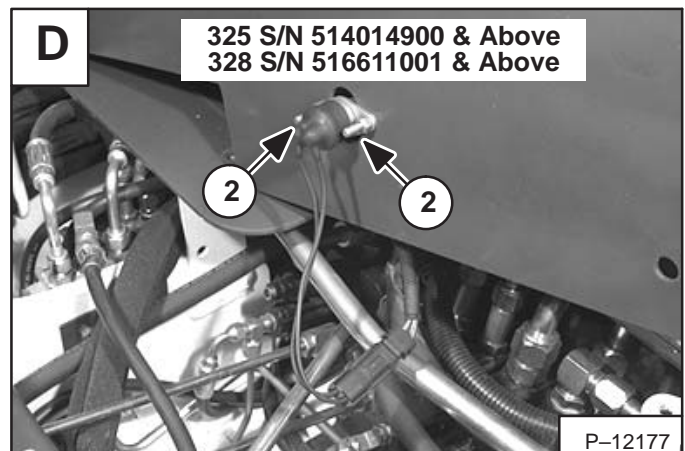
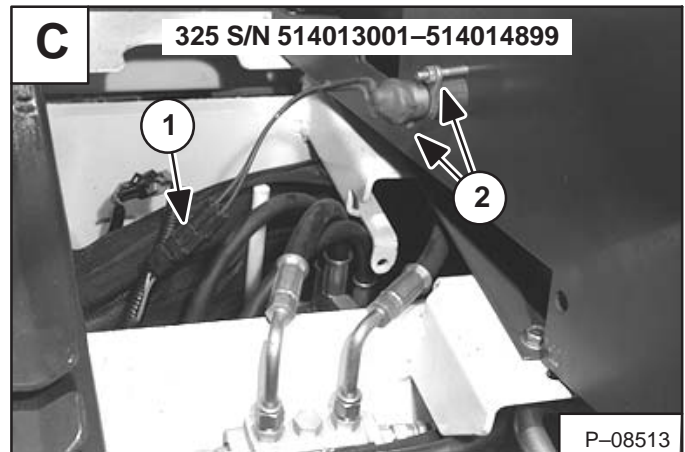

FUEL INJECTOR NOZZLES

Some problems caused by faulty injector nozzles:

- The engine is hard to start or will not start.
- Rough engine operation at idle.
- The engine will not have full power.
- The engine exhaust smoke is black, white or blue.

Removal And Installation

IMPORTANT

Do not bend the high pressure fuel injection tubes when removing or installing them.

I-2029-0289

Disconnect the high pressure fuel lines from the fuel injectors (Item 1) [A].

Disconnect the fuel lines from the injection pump.

Remove the high pressure fuel lines.

Disconnect the return fuel hose (Item 2) [A].

Remove the retainer nut from the top of the fuel injectors.

Remove the fuel return pipe [A].

Loosen the injector nozzle.

Installation: Tighten the injector nozzle to 36–51 ft.-lbs. (40–69 Nm) torque.

Remove the injector nozzle from the cylinder head [B].

NOTE: Be sure to replace the copper washer (Item 1) [B] and nozzle cap (Item 2) [B] anytime new or used fuel injectors are installed.

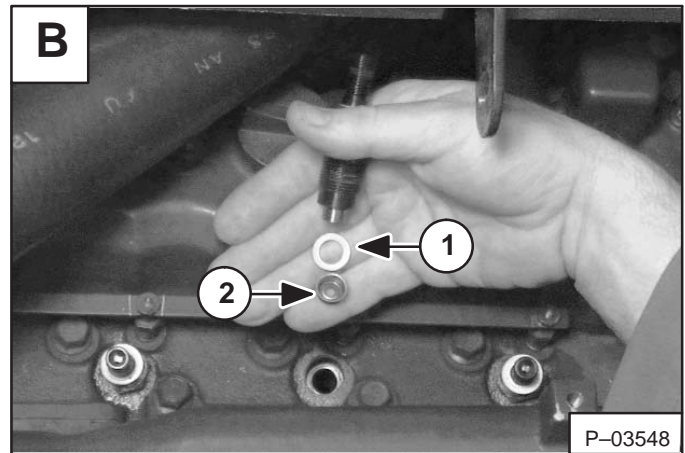
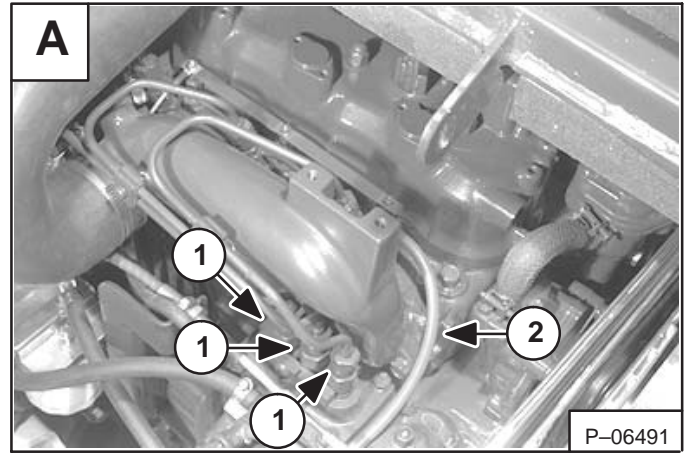

WARNING

Diesel fuel or hydraulic fluid under pressure can penetrate skin or eyes, causing serious injury or death. Fluid leaks under pressure may not be visible. Use a piece of cardboard or wood to find leaks. Do not use your bare hand. Wear safety goggles. If fluid enters skin or eyes, get immediate medical attention from a physician familiar with this injury.

W-2072-0496

ENGINE (Cont'd)

Removal And Installation (Cont'd)

For 325 S/N 514013001–514014899

Remove the wire (Item 1) [A] from the glow plugs.

Remove the fuel return hose (Item 2) [A].

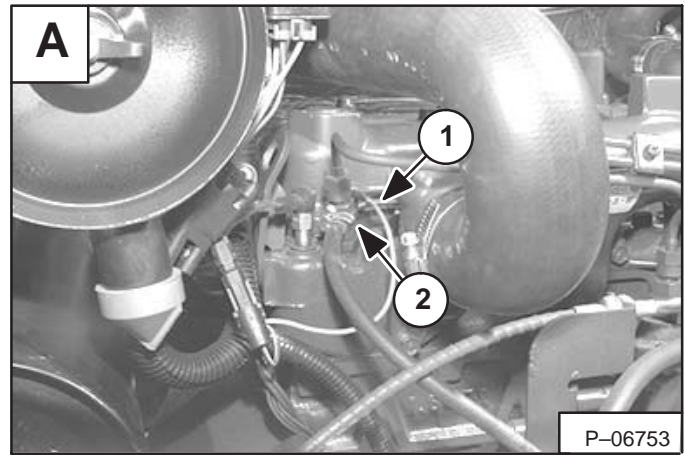

Disconnect the fuel shut off solenoid harness connector (Item 1) [B].

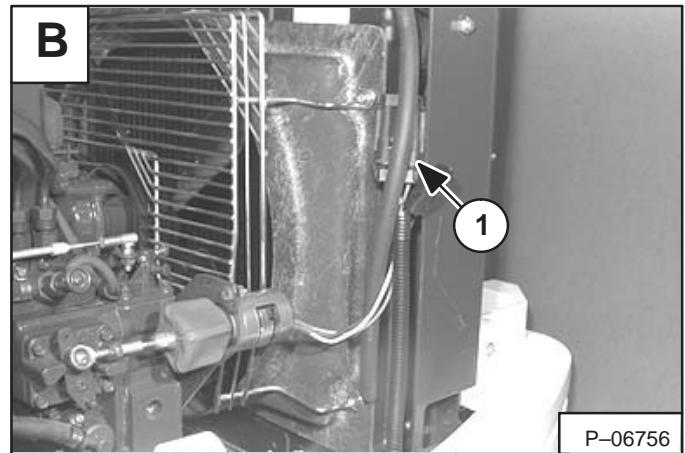

Disconnect the wires from the oil sender [C].

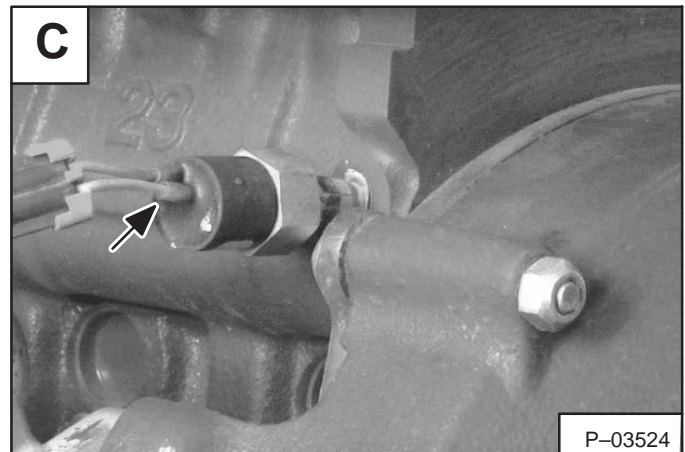

For All S/N Excavators

Remove the speed control cable ball joint (Item 1) [D].

Loosen the jam nut (Item 2) [D] and move the speed control cable out of the way.

Loosen the clamp (Item 3) [D] on the fuel lines.

Disconnect and plug the fuel lines.

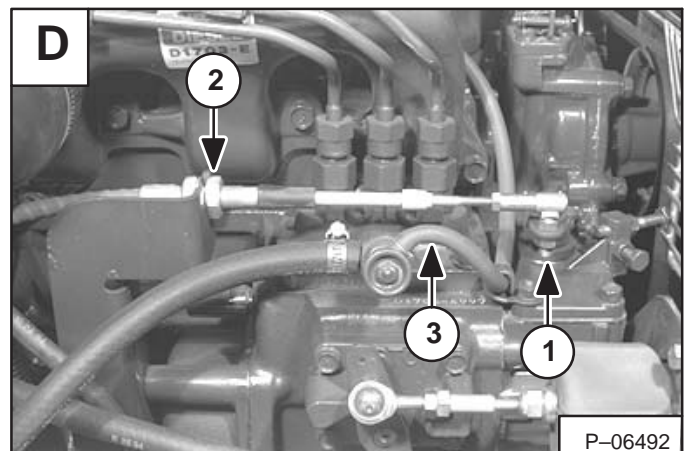

CYLINDER HEAD (Cont'd)

Servicing The Cylinder Head

Clean the surface of the cylinder head.

Put a straight edge (Item 1) [A] on the cylinder head.

NOTE: Do not put the straight edge across combustion chambers.

Put a feeler gauge (Item 2) [A] between the straight edge and the surface of the cylinder head.

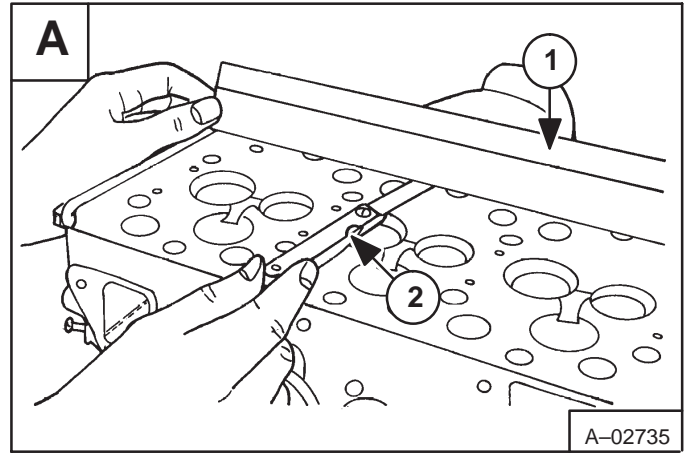

Put the straight edge on the cylinder head's four sides and two diagonal as shown in figure [B].

The maximum distortion of the head surface ± 0.002 inch ($\pm 0,051$ mm). If the measurement exceeds the specification, replace the cylinder head.

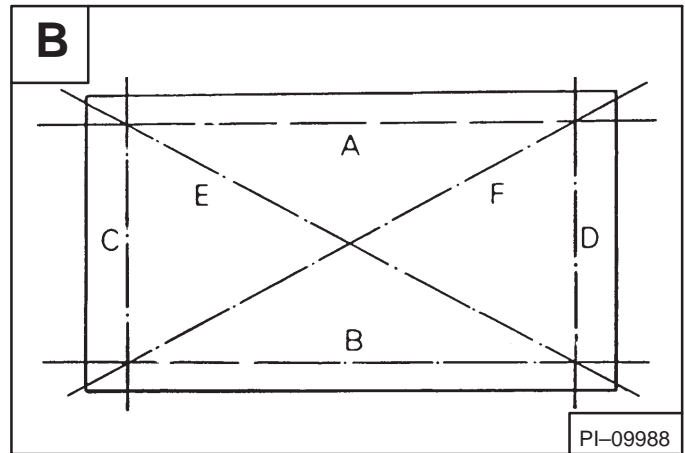

Top Clearance

Install the cylinder head gasket. Put the piston (Item 1) [C] being checked at T.D.C.

Put three pieces of 0.060 inch (1,5 mm) diameter solder (Item 2) [C] on the top piston. Use grease to hold them in position.

NOTE: Put the solder in position so they do not touch the valves.

Turn the piston to bottom dead center.

Install the cylinder head and tighten to the correct torque in the correct sequence. (See Page 7-28.)

Turn the crankshaft until the piston exceed T.D.C. Remove the cylinder head.

Remove the solder wire (Item 3) [C] and measure it.

If the measurement exceeds the specifications, check the oil clearance of the crank pin journal or the piston pin.

Top clearance . . . 0.0217-0.0276 inch (0,55-0,70 mm)

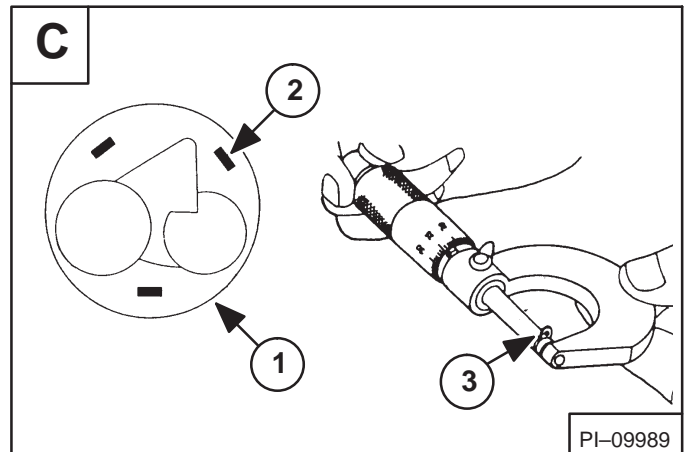

CRANKSHAFT GEAR

Removal And Installation

Remove the timing gearcase cover. (See Page 7-34.)

Remove the idler gear. (See Page 7-36.)

Remove the crankshaft gear with a puller [A].

Remove the crankshaft key.

Installation: Install the crankshaft key. Heat the crankshaft gear to 176°F (80°C) and fit it on the crankshaft.

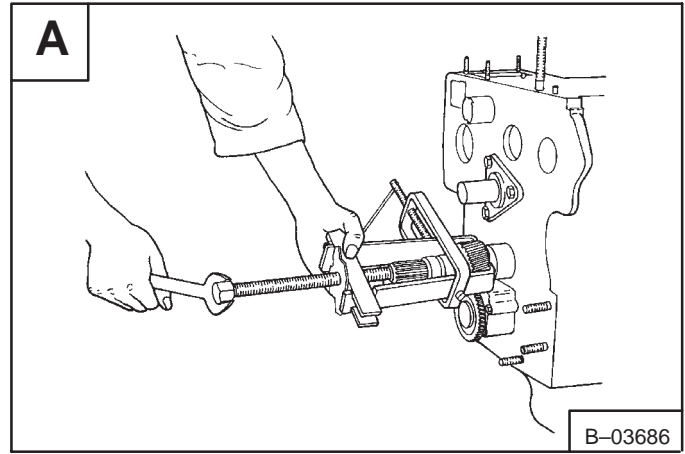

OIL PUMP

Removal And Installation

Remove the timing gearcase cover. (See Page 7-34.)

Remove the crankshaft gear.

Remove the nut from the oil pump shaft. Use a puller to remove the oil pump gear (Item 1) [B].

Remove the oil pump mounting bolts. Remove the oil pump (Item 2) [B].

Installation: Tighten the oil pump mounting bolts to 60-72 in.-lbs. (6,9-8,1 Nm) torque.

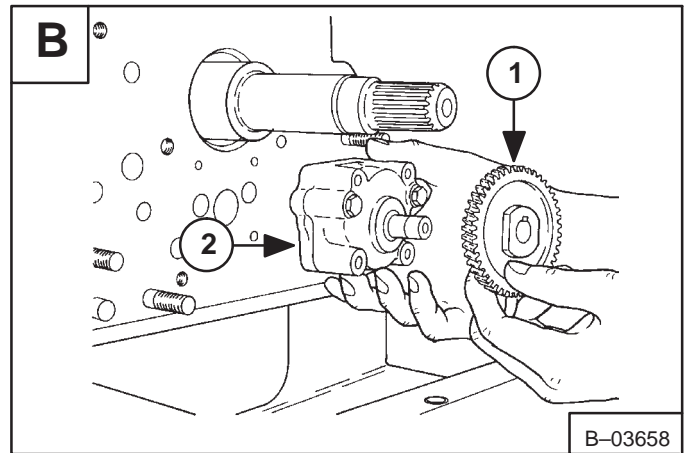

Oil Pump Service

Measure the clearance between the lobes of the inner rotor and outer rotor [C].

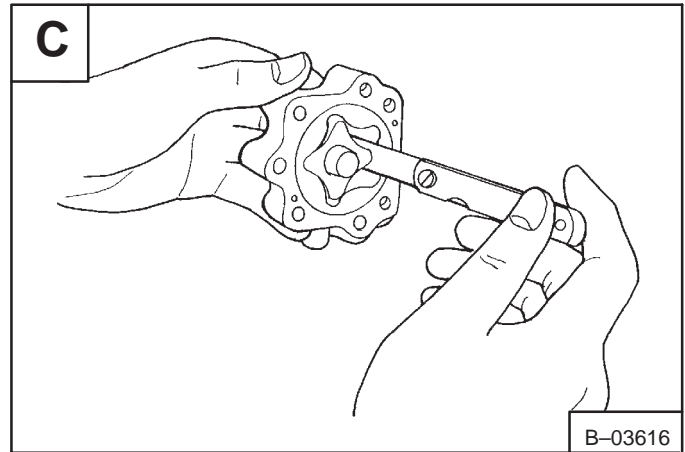

Measure the clearance between the outer rotor and pump body [D].

If the clearance exceeds the factory limit, replace the oil pump.

Clearance Between Inner & Outer Rotor 0.003-0.006 inch (0,10-0,16 mm)

Clearance Between Outer Rotor & Body 0.004-0.008 inch (0,11-0,19 mm)

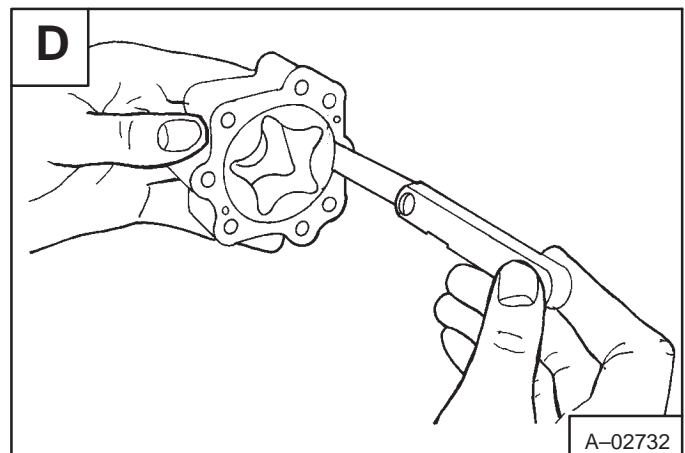

CYLINDER BORE

Checking The Cylinder Bore

Use a gauge to check the inside measurement of the cylinder bore **[A]**.

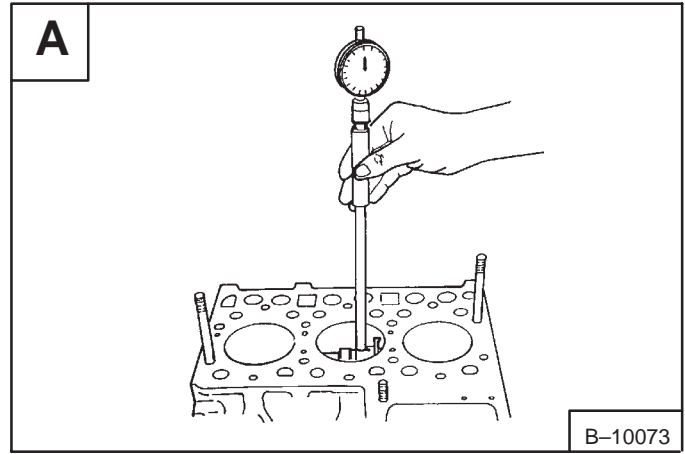

Measure the six points as shown in figure **[B]** to find the maximum wear.

The specifications is 3.425–3.426 inches (87,0–87,02 mm). The wear limit is +0.006 inch (+0,15 mm).

If the cylinder bore is not within specification, re-bore the cylinder for oversize piston.

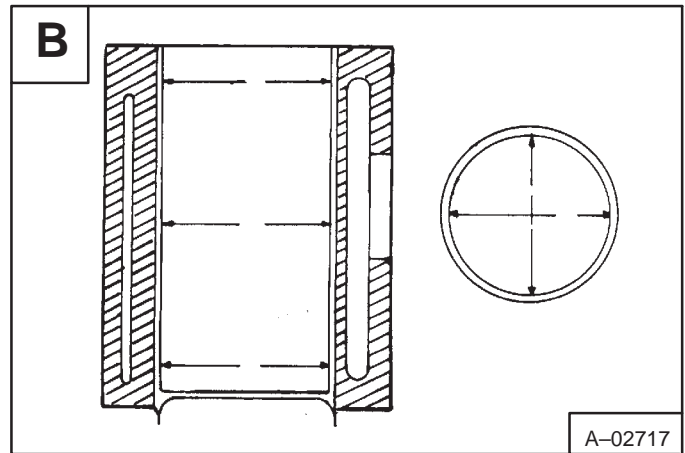

**HYDRAULIC EXCAVATOR SPECIFICATIONS (325 S/N 514014900 & ABOVE) & (328 S/N 516611001 & ABOVE)
(Cont'd)**

	325		
HYDRAULIC SYSTEM			
Number of Pumps	Three		
Type	Triple Section Gear Pump		
Capacity	1 x 8.14 GPM (30.8 L/min.) 2 x 6.39 GPM (24.2 L/min)		
System Main Relief Settings			
Blade Circuit	2650 PSI (18272 kPa)		
Bucket & Arm Circuits	2550 PSI (17582 kPa)		
Boom Circuits	2700 PSI (18617 kPa)		
Travel Circuits	3700 PSI (25512 kPa)		
Swing Circuits	4200 PSI (28959 kPa)		
Auxiliary Flow	14.5 GPM (55,0 L/min.)		
Control Valve(s)	5 Spool Parallel & Series Type		
Drive Motors	Two Axial Piston		
Swing Motor	Orbit Motor		
Hydraulic Function Time			
Bucket	Curl 1.8 Sec.	Dump 1.4 Sec.	
Arm	Retract 3.3 Sec.	Extend 2.9 Sec.	
Boom	Raise 2.4 Sec.	Lower 3.0 Sec.	
Boom Swing	Left 2.3 Sec.	Right 2.3 Sec.	
Blade	Raise 3.4 Sec.	Lower 2.7 Sec.	
SWING SYSTEM			
Swing Drive	Orbit Motor, Direct Drive		
Swing Circle	Single Row Shear Type Ball Bearings with Internal Gears Built into Swing Circle		
Swing Speed	11,7 RPM		
HYDRAULIC CYLINDERS	Bore Dia. in. (mm)	Rod Dia in. (mm)	Stroke in. (mm)
Boom	2.75 (70)	1.50 (38)	18.68 (474)
Arm	2.75 (70)	1.50 (38)	19.61 (498)
Bucket	2.75 (70)	1.50 (38)	17.04 (433)
Boom Swing	2.38 (60)	1.38 (35)	15.75 (400)
Blade	2.75 (70)	1.50 (38)	7.68 (195)
DRIVE SYSTEM			
Final Drive	Each Track is Independently Driven by a Hydrostatic Axial Piston Motor		
Type of Reduction	Two Stage Planetary Gear Reduction – 44:1		
Max. Drawbar Pull	5000 lbs. (2668 kg)		
Gradeability	30 Degrees		
BRAKES			
Travel			
Service	Hydraulic Lock on Motor		
Parking	Hydraulic Lock on Motor		
Swing			
Service	Hydraulic Lock on Motor		
Holding	Pin Lock		
UNDERCARRIAGE			
Type	Crawler–Tractor Design Undercarriage. Sealed Track Rollers with Reinforced Box–Section track Roller Frame. Grease Type Track Adjusters with Shock absorbing Recoil Springs.		
STD TRACK			
Type	Rubber		
Width	12.6" (320 mm)		
No. of Shoes	Single Assemble		
No. of Track Rollers	3 each Side		
Ground Pressure	4.2 PSI (29 kPa)		
CAPACITIES			
Fuel Tank	9.9 gal. (37,5 L)		
Cooling System	7.0 qts. (6,6 L)		
Engine Oil & Filter	6.0 qts. (5,7 L)		
Hydraulic Reservoir	6.9 gal. (26 L)		
DIGGING FORCE			
Arm	2626 lbf. (11681 N)		
Bucket	4567 lbf. (20315 N)		

CLICK HERE TO **DOWNLOAD** THE COMPLETE MANUAL

- Thank you very much for reading the preview of the manual.
- You can download the complete manual from: www.heydownloads.com by clicking the link below



- Please note: If there is no response to CLICKING the link, please download this PDF first and then click on it.

CLICK HERE TO **DOWNLOAD** THE COMPLETE MANUAL