



Bobcat®

Service Manual



UV34 UV34XL

Utility Vehicle

(UV34) S/N B4LW11001 & Above
(UV34XL) S/N B4LZ11001 & Above
(UV34) S/N B53611001 & Above
(UV34XL) S/N B53711001 & Above



CLICK HERE TO **DOWNLOAD** THE COMPLETE MANUAL

- Thank you very much for reading the preview of the manual.
- You can download the complete manual from: www.heydownloads.com by clicking the link below



- Please note: If there is no response to CLICKING the link, please download this PDF first and then click on it.

CLICK HERE TO **DOWNLOAD** THE COMPLETE MANUAL

SAFETY INSTRUCTIONS



Safety Alert Symbol

This symbol with a warning statement means: **“Warning, be alert! Your safety is involved!”** Carefully read the message that follows.



WARNING

Operator must have instructions before operating the utility vehicle. Untrained operators can cause injury or death.

W-2855-0510

IMPORTANT

This notice identifies procedures which must be followed to avoid damage to the utility vehicle.

I-2317-0510



DANGER

The signal word **DANGER** on the utility vehicle and in the manuals indicates a hazardous situation which, if not avoided, will result in death or serious injury.

D-1022-0510



WARNING

The signal word **WARNING** on the utility vehicle and in the manuals indicates a potentially hazardous situation which, if not avoided, could result in death or serious injury.

W-2856-0510

The following publications provide information on the safe use and maintenance of the Bobcat utility vehicle and attachments:

- The Delivery Report is used to assure that complete instructions have been given to the new owner and that the vehicle is in safe operating condition.
- The Operation & Maintenance Manual delivered with the vehicle or attachment contains operating information as well as routine maintenance and service procedures. It is a part of the vehicle and can be stored in a container provided on the vehicle. Replacement Operation & Maintenance Manuals can be ordered from your Bobcat dealer.
- Safety signs (decals) instruct on the safe operation and care of your Bobcat utility vehicle or attachment. The signs and their locations are shown in the Operation & Maintenance Manual. Replacement signs are available from your Bobcat dealer.
- An Operator's Handbook fastened to the operator cab. It's brief instructions are convenient to the operator. The handbook is available from your dealer in an English edition or one of many other languages. See your Bobcat dealer for more information on translated versions.
- The Service Manual and Parts Manual are available from your dealer for use by mechanics to do shop-type service and repair work.
- The Utility Vehicle Operator Training Course is available through your local dealer or at **Bobcat.com/training** or **Bobcat.com**. This course is intended to provide rules and practices of correct operation of the utility vehicle. The course is available in English and Spanish versions.
- The Utility Vehicle Safety Video is available from your Bobcat dealer or at **Bobcat.com/training** or **Bobcat.com**.

LIFTING AND BLOCKING THE UTILITY VEHICLE

Procedure

For service work under the utility vehicle, or to remove the wheels, always support the utility vehicle with jackstands or blocks of adequate capacity for weight of utility vehicle. (See Performance on Page SPEC-10-3.)

Always park the utility vehicle on a flat level surface.

Stop the engine and put the gear selector in PARK.

If removing wheel(s), loosen the wheel nuts slightly before lifting the vehicle.



AVOID INJURY OR DEATH

Instructions are necessary before operating or servicing machine. Read and understand the Operation & Maintenance Manual, Operator's Handbook and signs (decals) on machine. Follow warnings and instructions in the manuals when making repairs, adjustments or servicing. Check for correct function after adjustments, repairs or service. Untrained operators and failure to follow instructions can cause injury or death.

W-2003-0807

Figure 10-10-1

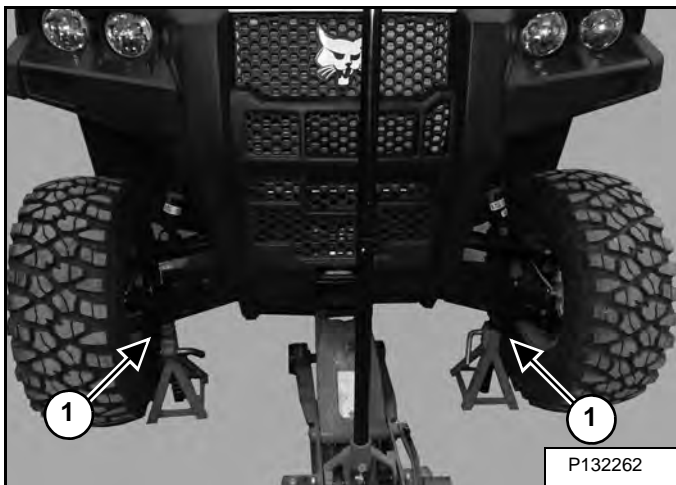

Place the jackstands (Item 1) [Figure 10-10-1] under the frame at the front of the utility vehicle.

NOTE: When lifting the utility vehicle, place the jack under front frame [Figure 10-10-1].

Figure 10-10-2

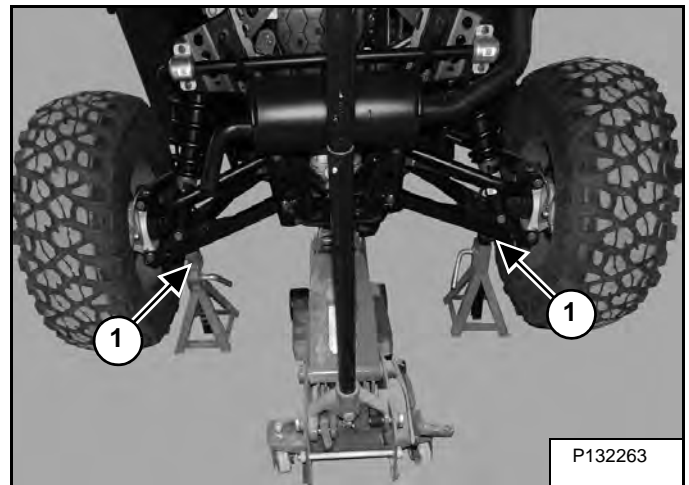

Place the jackstands (Item 1) [Figure 10-10-2] under the rear frame of the utility vehicle.

NOTE: When lifting the utility vehicle, place the jack under the rear frame [Figure 10-10-2].

SERVICE SCHEDULE (CONT'D)

Maintenance Intervals (Cont'd)

Every 500 Hours or Every 5000 Miles

- **Cooling System** - Replace coolant. *(Or Every 2 Years whichever comes first).*
- **Spark Plugs** - Replace. Torque to specifications.
- **Toe Adjustment** - Inspect and adjust as necessary. Replace parts as needed.

[1] Change yearly.

[2] Perform these procedures more often for vehicles subject to severe use.

[3] Replace lines every two years.

[4] The wheel nuts must be checked and torqued after the first eight hours of operation of a new machine and after the first eight hours of operation when the wheel(s) have been removed for service.

SS UV 34 G-1219

FUEL SYSTEM (CONT'D)

Fuel Filter

The fuel filter is an integral part of the fuel pump located inside the fuel tank. (See SERVICE SCHEDULE on Page 10-50-1.)

Filling A Portable Fuel Container

Static electric spark can explosively ignite gasoline vapors when filling ungrounded portable containers.

Always put the container **ON THE GROUND** before filling.

Keep the nozzle in contact with container while filling.

NEVER fill container in the cargo box or on the utility vehicle.



WARNING

FIRE AND EXPLOSION CAN CAUSE SERIOUS INJURY OR DEATH

Static electric spark can explosively ignite gasoline vapors when filling ungrounded portable containers.

- **ALWAYS** place the container **ON THE GROUND** before filling.
- **Keep** the nozzle in contact with container while filling.
- **NEVER** fill container in the cargo box, storage bins or on the machine.

W-2801-0709

GEARCASE (CONT'D)

Front Gearcase Fluid

For the correct fluid information, (See Fluid And Capacities on Page SPEC-10-5.)

Adding Front Gearcase Fluid

Thoroughly clean the area around the fill / check plug before removal.

If needed, remove the fill / check plug (Item 1) **[Figure 10-110-1]**. Use a long neck, flexible funnel and add fluid until it is at the bottom edge of the plug opening.

Reinstall the plug and tighten to 11 -13 N•m (8 - 10 ft-lb) torque.

Removing And Replacing Front Gearcase Fluid

Replace front gearcase fluid at the correct service interval. (See SERVICE SCHEDULE on Page 10-50-1.)

Replace the fluid if it becomes contaminated.

Raise the front of the vehicle and install jackstands.

Install a funnel and a container under the drain plug (Item 1) **[Figure 10-110-4]**. (See Fluid And Capacities on Page SPEC-10-5.)

Remove the drain plug (Item 1) **[Figure 10-110-4]**. Dispose of the used fluid in an environmentally safe manner.

Reinstall the drain plug (Item 1) **[Figure 10-110-4]** and tighten to 11 - 13 N•m (8 - 10 ft-lb) torque.

Remove jackstands and lower the vehicle to the ground before adding fluid to make sure the fluid level is correct.

Thoroughly clean the area around the fill / check plug before removal.

Remove the fill / check plug (Item 1) **[Figure 10-110-3]**. Use a long neck, flexible funnel and add fluid until it is at the bottom edge of the plug opening.

Reinstall the fill / check plug (Item 1) **[Figure 10-110-3]** and tighten to 11 -13 N•m (8 - 10 ft-lb) torque.



AVOID INJURY OR DEATH

Always clean up spilled fuel or oil. Keep heat, flames, sparks or lighted tobacco away from fuel and oil. Failure to use care around combustibles can cause explosion or fire.

W-2103-0508

Start the engine and operate the utility vehicle.

Stop the engine and check for leaks.

Check fluid level and add as needed.

STOPPING THE ENGINE AND LEAVING THE UTILITY VEHICLE

Procedure

! WARNING

AVOID INJURY OR DEATH

Before you leave the operator's seat:

- Park on flat level ground.
- Press the brake pedal and move the gear selector lever to PARK.
- Stop the engine and remove the key.

W-2974-1212

Figure 10-150-1



Park the vehicle on a flat and level surface [Figure 10-150-1].

Figure 10-150-2

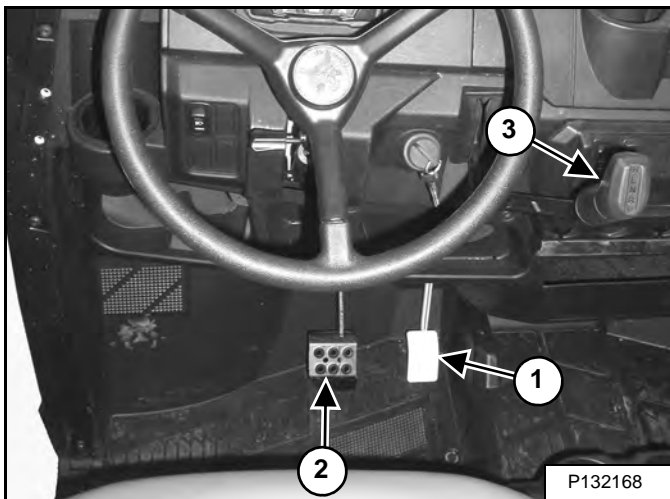

Release the throttle pedal (Item 1) completely and apply the brake pedal (Item 2) [Figure 10-150-2] and come to a complete stop.

Move the gear selector lever (Item 3) [Figure 10-150-2] to PARK.

NOTE: When parking inside an enclosed area, be sure that the structure is a well ventilated area.

Turn the engine OFF and remove the key to prevent unauthorized use.

! WARNING

ROLLAWAY CAN CAUSE SERIOUS INJURY OR DEATH

Always put the gear selector lever in PARK before stopping the engine.

W-2962-1212

Figure 10-150-3



Press the red release button (Item 1) [Figure 10-150-3] to disconnect the seat belt.

BRAKE

General Specifications

FRONT BRAKE SYSTEM

Item	Standard	Service Limit
Front Brake Pad Thickness	3,8 mm (0.15 in)	1 mm (0.040 in)
Front Brake Disc Thickness	4,78 mm (0.188 in)	4,32 mm (0.170 in)
Front Brake Disc Thickness Variance		0,051 mm (0.002 in)
Front Brake Disc Runout		0,254 mm (0.010 in)
Front Caliper Piston Bore I.D.	34,87 mm (1.373 in)	34,93 mm (1.375 in)
Front Caliper Piston O.D.	34,80 mm (1.370 in)	34,75 mm (1.368 in)

REAR BRAKE SYSTEM

Item	Standard	Service Limit
Rear Brake Pad Thickness	3,8 mm (0.15 in)	1 mm (0.040 in)
Rear Brake Disc Thickness	4,78 mm (0.188 in)	4,32 mm (0.170 in)
Rear Brake Disc Thickness Variance		0,051 mm (0.002 in)
Rear Brake Disc Runout		0,254 mm (0.010 in)
Rear Caliper Piston Bore I.D.	38,23 mm (1.505 in)	38,28 mm (1.507 in)
Rear Caliper Piston O.D.	38,10 mm (1.500 in)	38,05 mm (1.498 in)

Torque Specifications

Item	Torque N•m	Torque ft-lb
Front Brake Disc to Hub Bolts	24	18
Rear Brake Disc to Hub Bolts	38	28
Brake Line Banjo Bolts (All)	20	15
Brake Switch	20	15
Caliper Bleed Screws	6	4
Front Caliper Mounting Bolts	41	30
Rear Caliper Mounting Bolts	62	46
Master Cylinder Mounting Bolts	31	23
Rear Wheel Hub Castle Nut	149	110
Brake Pedal Mount Bracket Nuts	24	18
Wheel Nuts (Steel Wheels)	81	60
Front Wheel Hub Castle Nut	149	110

BRAKE (CONT'D)

Brake Inspection

Figure 20-10-11

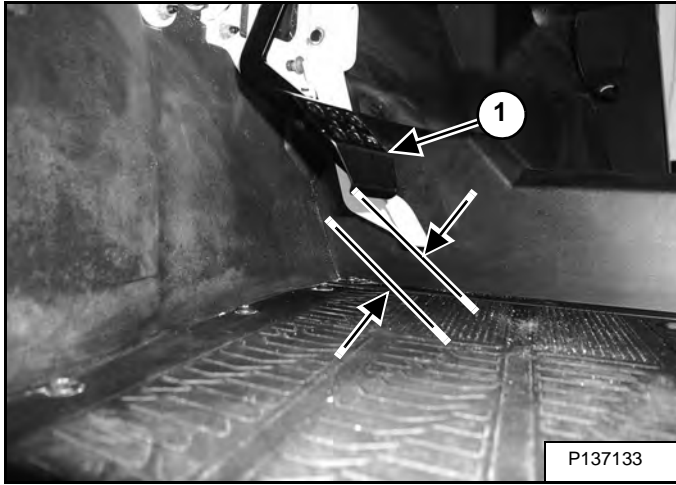

Position the utility vehicle on a flat level surface. Engage the park brake and stop the engine. Exit the utility vehicle.

Check the brake pedal (Item 1) [Figure 20-10-11] for excessive travel or a spongy feel.

The correct amount of free travel on the brake pedal is 2,29 mm (0.090 in) [Figure 20-10-11].

Brake Pad Inspection

Figure 20-10-12

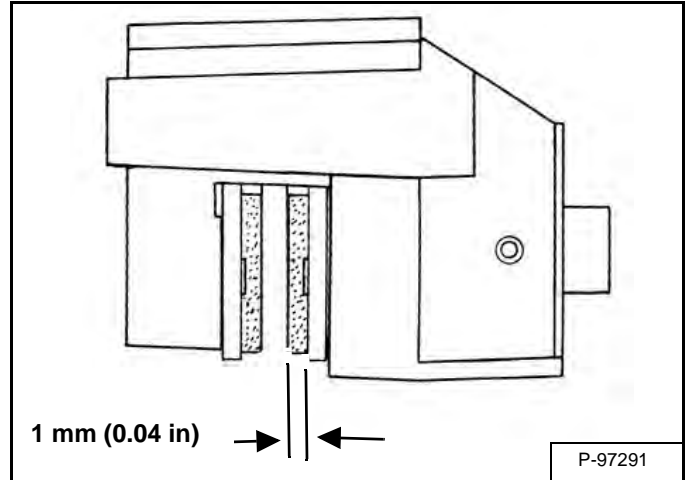

The minimum pad thickness is 1 mm (0.04 in) [Figure 20-10-12].

NOTE: The tires must be removed to inspect brake pads. (See Tires on Page 10-120-1.)

Burnishing

It is required that a burnishing procedure be performed after installation of new brake pads to extend service life and reduce noise.

Start machine and slowly increase speed to 48,3 km/h (30 mph). Gradually apply brakes to stop machine. Allow pads and disc to cool sufficiently during the procedure. Do not allow pads or disc to become hot or warping may result. **Do not make more than 3 stops per 1,6 km (1.0 mile).** Repeat this procedure 10 times.

BRAKE (FRONT) (CONT'D)

Disc Runout

Figure 20-11-22

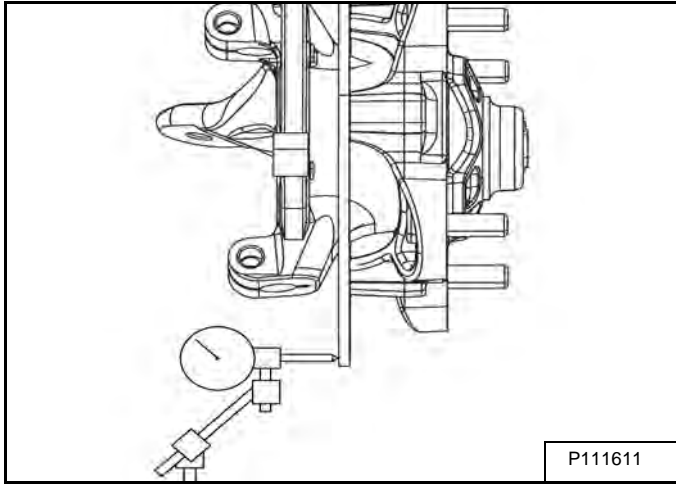

Mount dial indicator as shown to measure disc runout. Slowly rotate the disc and read total runout on the dial indicator. Replace the disc if runout exceeds specification **[Figure 20-11-22]**.

Brake Disc Runout

Service Limit	0,254 mm (0.10 in)
---------------	--------------------

Disc Inspection

Lift and block the machine. (See **LIFTING AND BLOCKING THE UTILITY VEHICLE** on Page 10-10-1.)

Remove the tire assembly. (See **Wheel Removal And Installation** on Page 10-120-2.)

Figure 20-11-23

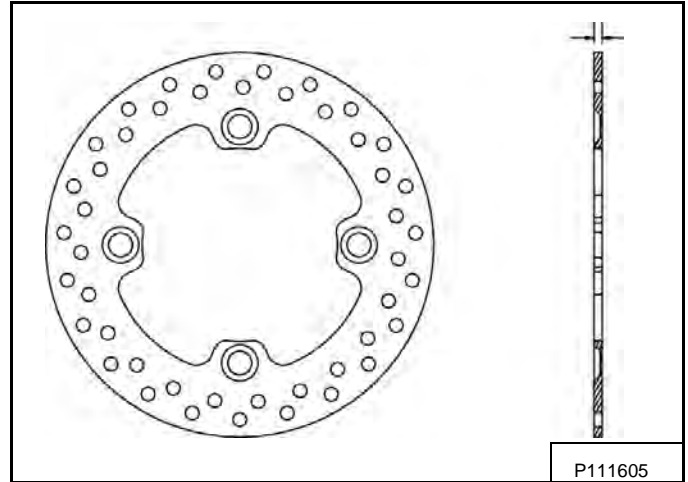

Visually inspect disc for scoring, scratches, or gouges. Replace the disc if any deep scratches are evident.

Use a 0 - 1 inch micrometer and measure the disc thickness at eight different points around the pad contact surface. Replace disc if worn beyond service limit **[Figure 20-11-23]**.

Brake Disc Thickness

New	4,78 mm (0.188 in)
Service Limit	4,32 mm (0.170 in)

Brake Disc Thickness Variance Difference Between Measurements

Service Limit	0,051 mm (0.002 in)
---------------	---------------------

TRANSMISSION

General Operation

The vehicle's transmission has three traction operational modes: 4WD (4x4), 2WD (Differential Locked) and Turf (Differential Unlocked). Locking the rear differential is beneficial in low traction and rough terrain conditions. Unlocking the rear differential makes maneuvering easier and minimizes damage to turf and sensitive terrains.

Figure 20-20-1

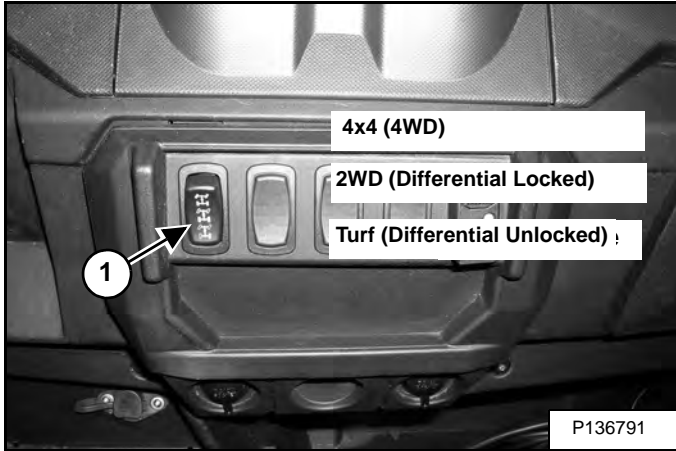

When “Differential-Unlocked” is selected on the switch, the rear differential becomes unlocked for tighter turns. An electrical solenoid mounted in the rear portion of the transmission actuates the shift fork. The solenoid plunger extends out to move the shift fork and slides the engagement dog away from the side gear that is part of the planetary differential assembly. This unlocks the rear differential. The rear drive shafts are now dependent on the differential allowing for tighter turns

Figure 20-20-2

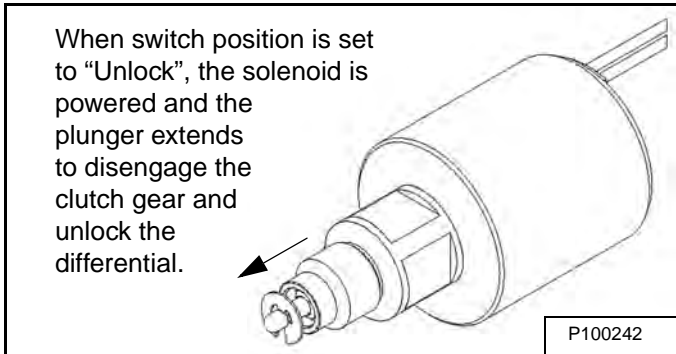

When switch position is set to “Unlock”, the solenoid is powered and the plunger extends to disengage the clutch gear and unlock the differential.

Figure 20-20-3

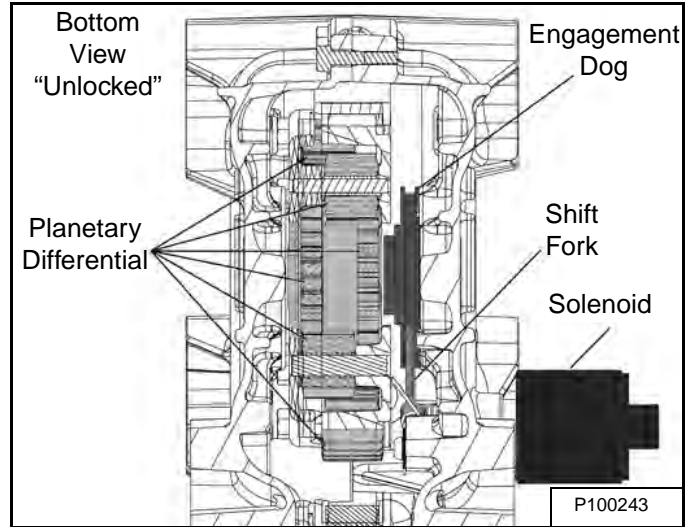

When “Differential-Locked” is selected on the switch, power is removed from the electrical solenoid allowing the solenoid plunger to retract. Spring tension moves the shift fork back into place and engages the engagement dog to the side gear that is part of the planetary differential assembly. This locks the rear differential as a solid rear axle, increasing traction.

Figure 20-20-4

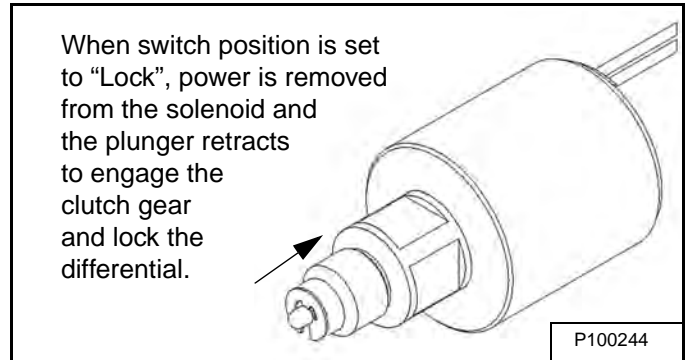

When switch position is set to “Lock”, power is removed from the solenoid and the plunger retracts to engage the clutch gear and lock the differential.

Figure 20-20-5

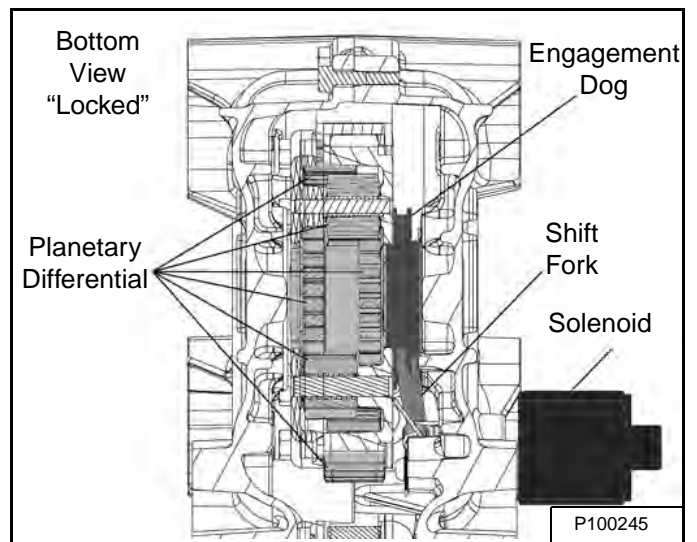

TRANSMISSION (CONT'D)

Removal (Cont'd)

Figure 20-20-33

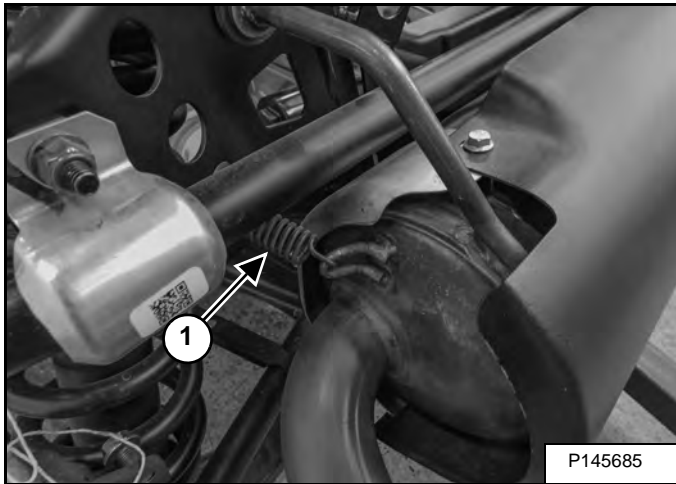

Remove the spring (Item 1) [Figure 20-20-33] from the muffler (both sides).

Remove the muffler.

Figure 20-20-34

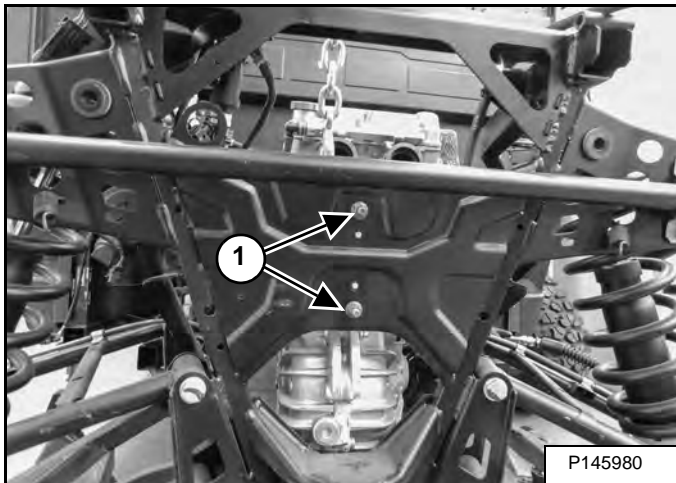

Remove the nuts (Item 1) [Figure 20-20-34] from the rear transmission isolator.

Figure 20-20-35

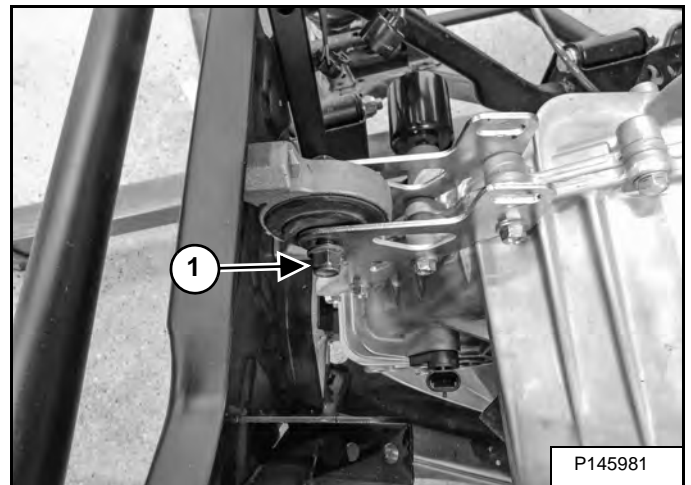

Remove the bolt and nut (Item 1) [Figure 20-20-35] from the rear transmission isolator.

Remove the isolator.

Figure 20-20-36

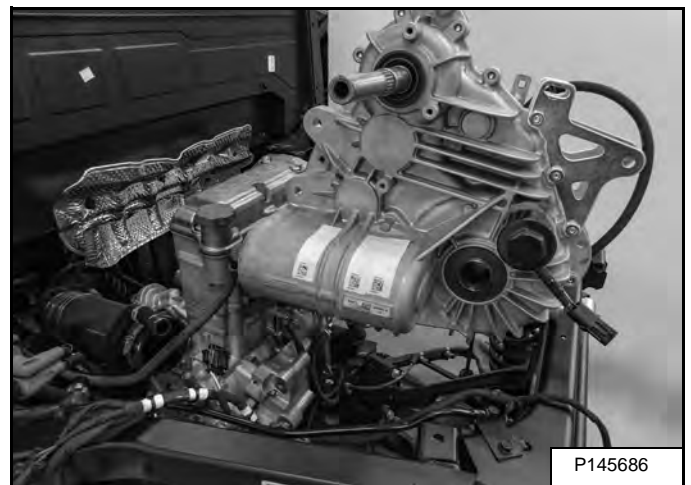

Remove the transmission [Figure 20-20-36].

NOTE: Have an assistant help guide the transmission in and out of the vehicle while using a hoist to prevent personal injury or damage to the vehicle.

TRANSMISSION (CONT'D)

Transmission Disassembly

Place the transmission in HIGH gear before disassembly.

Figure 20-20-59

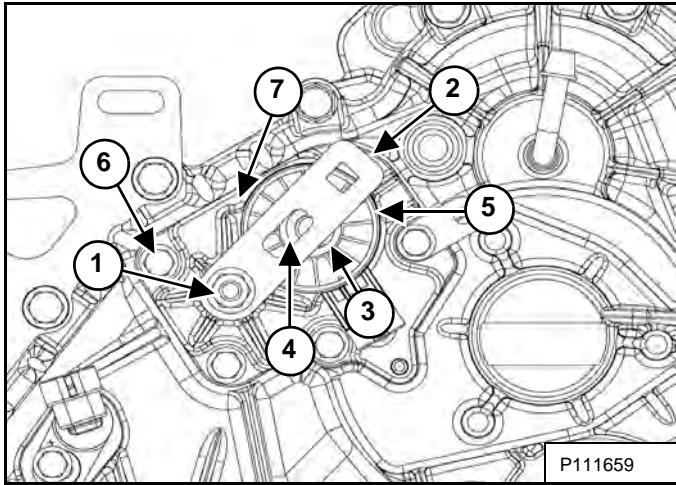

Remove the bellcrank nut (Item 1) and bellcrank (Item 2) [Figure 20-20-59]

Remove the E-clip (Item 3) that retains the spring washer (Item 4), flat washer and gear switch (Item 5) [Figure 20-20-59]. Remove the switch.

Remove the sector cover bolts (Item 6) and remove the sector cover (Item 7) [Figure 20-20-59].

NOTE: Removal can be aided by using your thumbs to press in on the shafts while pulling out the cover with your fingers.

Figure 20-20-60

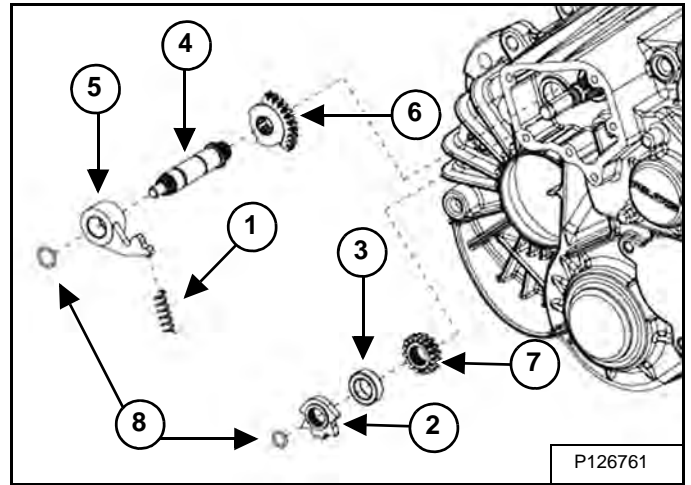

Remove the compression spring (Item 1) [Figure 20-20-60].

Remove the detent star (Item 2). [Figure 20-20-60] Note how the detent star fits onto the splined shaft with the skip tooth aligned and tall center hub facing outward for reassembly.

Remove the spacer (Item 3) [Figure 20-20-60]

Remove the shift shaft (Item 4), detent pawl (Item 5) and the shift sector gears (Item 6) and (Item 7) [Figure 20-20-60].

NOTE: Note the timing marks on the shift gears (Item 6) and (Item 7) [Figure 20-20-60] for reassembly.

Remove the O-rings (Item 8) [Figure 20-20-60] from each shaft and discard. Use new O-rings upon assembly.

Figure 20-20-61

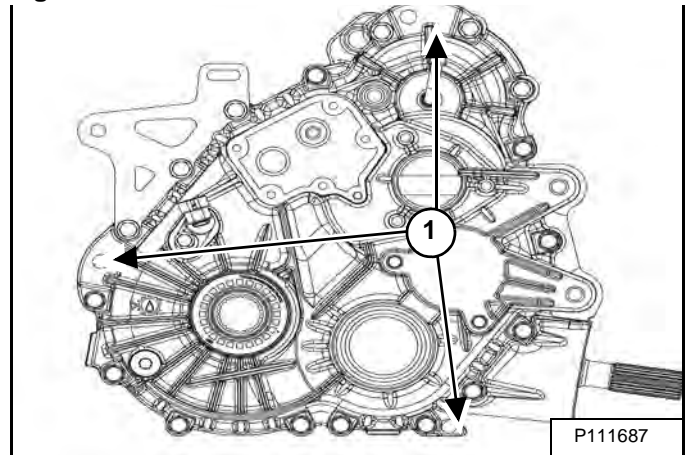

Remove all the transmission case bolts. Using suitable pry bars, remove the cover using the designated pry points (Item 1) [Figure 20-20-61].

TRANSMISSION (CONT'D)

Snorkel Gear Backlash

Figure 20-20-93

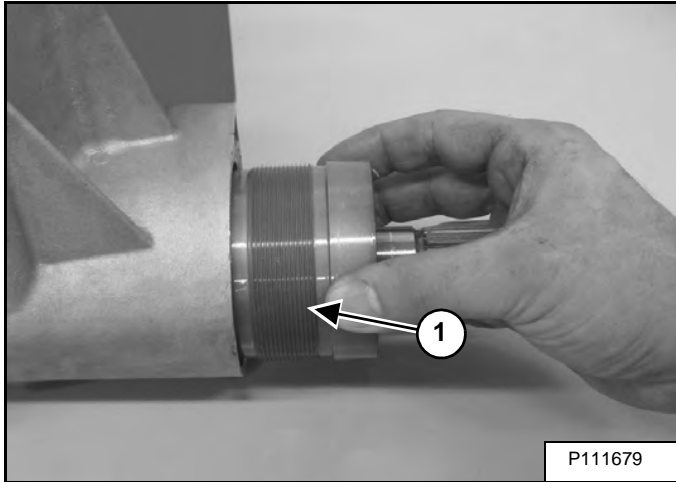

After the 13T gear and bearing are pressed onto the snorkel shaft (flush to the shoulder), install the washer and new retaining ring.

Press the gear back towards the retaining ring. Avoid excessive force so the retaining ring is not damaged or prestressed significantly.

Failure to press the gear back against the washer and retaining ring will lead to a gear backlash change after vehicle is placed into service.

Apply a small amount of white lithium grease or Anti-Seize on the threads (Item 1) [Figure 20-20-93] of the snorkel tube.

Figure 20-20-94

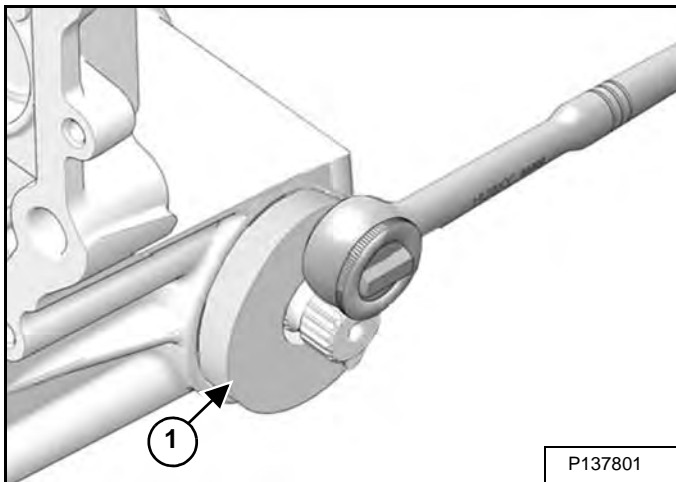

Install the snorkel shaft into the gearcase. Using the Snorkel Tool (PA-552547), (Item 1) [Figure 20-20-94] tighten the snorkel tube until it is lightly seated in the transmission housing.

Inspect the pinion shaft assembly. Replace bearings if needed. Inspect each gear for damage, chips or abnormally worn teeth.

NOTE: If pinion shaft was disassembled, the bearing cover must be installed on the shaft before installing the 46T gear.

Install the pinion shaft assembly. Be sure to properly mesh the snorkel shaft bevel gear with the pinion shaft bevel gear.

Figure 20-20-95

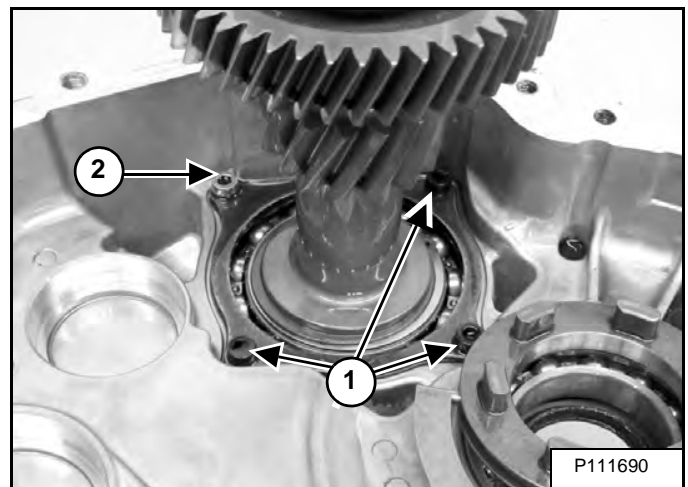

Apply Loctite® 242 to the threads of the bearing cover retaining screws.

Install only the three screws (Item 1) [Figure 20-20-95] that secure the pinion shaft assembly as shown. Leave the longer locking screw (Item 2) [Figure 20-20-95] out at this point.

Tighten the screws to 11 - 14 N•m (8 - 10 ft-lb) torque.

Rotate the snorkel tube counterclockwise using the snorkel tool (PA-50231) until the snorkel gear and pinion gear have 'zero' backlash.

NOTE: DO NOT over tighten the snorkel tube when backing it out. At the "zero" backlash position, you should still be able to turn the snorkel shaft using your fingers, but it will feel rough and may have some tight spots.

Look down into the transmission housing to see the snorkel locking screw hole opening to reference your starting point.

DRIVE BELT (CONT'D)

Belt Inspection

Inspect the belt for hourglass (extreme circular wear in at least one spot and on one side of the belt). Hour glassing occurs when the drive train does not move and the drive clutch engages on the belt.

Inspect belt for loose cords, missing cogs, cracks, abrasion, thin spots, or excessive wear. Compare belt measurements with a new belt. Replace as needed.

Belts with thin spots, burn marks, etc. should be replaced to eliminate noise, vibration, or erratic CVT operation.

Figure 20-30-5

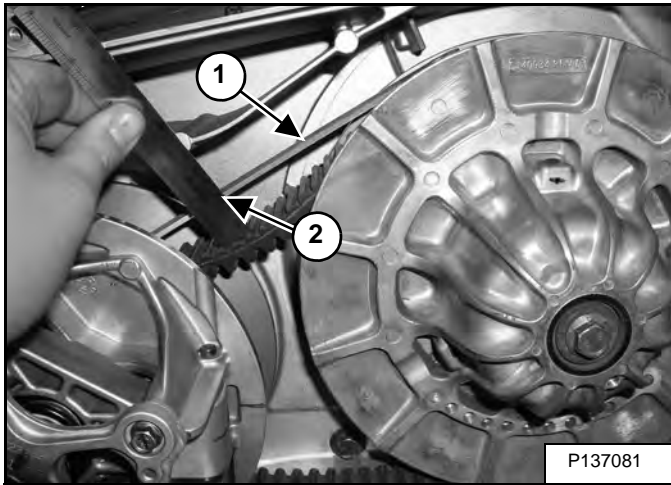

Make sure the belt can be rotated by hand and that the drive clutch is fully open and the driven clutch is in the closed position.

To check belt deflection (stretch), place a straight edge (Item 1) over the top of the belt. Press down in the center of the belt until lightly tensioned and measure (Item 2) **[Figure 20-30-5]** the belt deflection.

The correct deflection is 29 - 32 mm (1.12 - 1.25 in).

If the belt deflection is out of range, either install a new belt or the driven clutch will need to be adjusted.

CONTINUOUS VARIABLE TRANSMISSION (CVT) (CONT'D)

CVT Sealing, Guard And Ducting Components Parts Identification

- 1. Clutch Hose Duct
- 2. Clutch Intake Duct
- 3. Inlet Duct Hose
- 4. Clutch Outlet Duct
- 5. Hose Clamp
- 6. Screw
- 7. Inner Clutch Cover
- 8. Outer Clutch Cover Seal
- 9. Outer Clutch Cover
- 10. Bolt

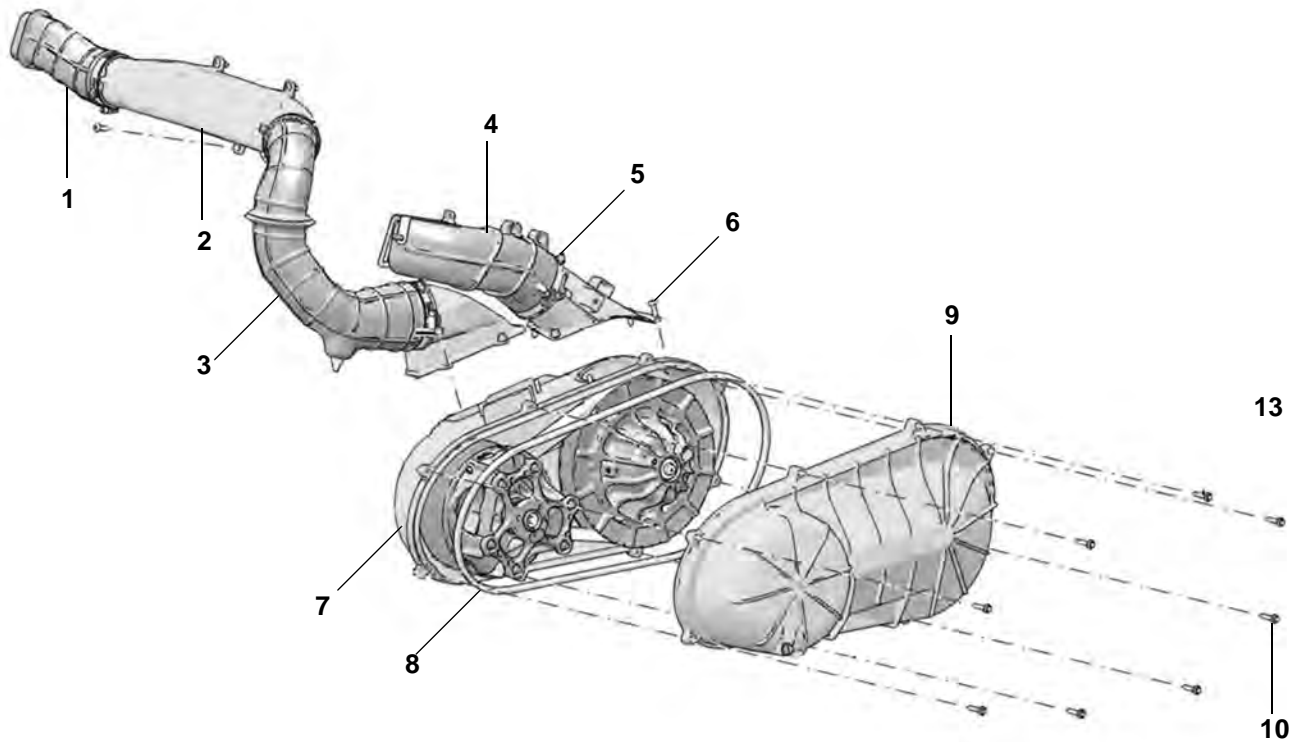

NA18448

CONTINUOUS VARIABLE TRANSMISSION (CVT) (DRIVE CLUTCH) (CONT'D)

Disassembly (Cont'd)

Clutch Inspection

Figure 20-41-12

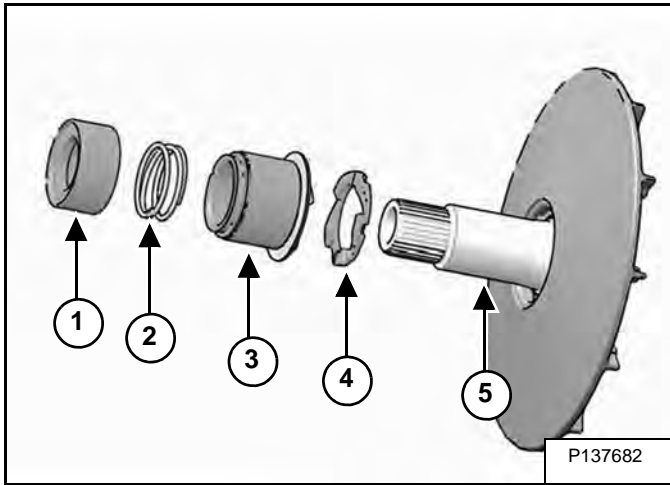

Remove the clutch spacer (Item 1), spring (Item 2), flange sleeve assembly (Item 3) and drive helix (Item 4) from the sheave assembly (Item 5) [Figure 20-41-12].

Figure 20-41-13

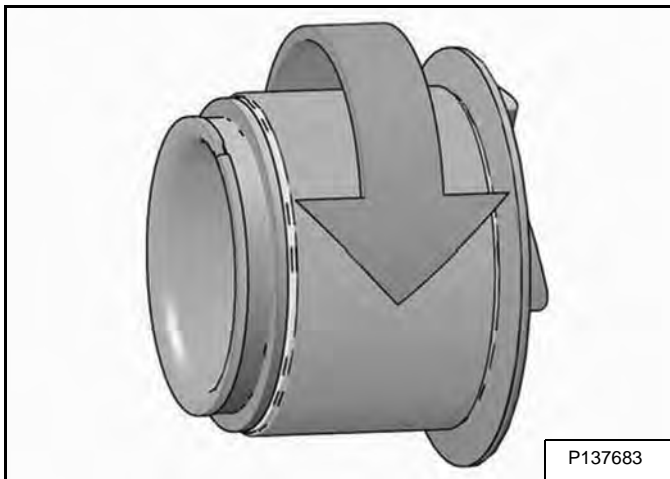

Rotate the clutch bearing in both clockwise and counterclockwise directions. The bearing should rotate clockwise and lock counterclockwise [Figure 20-41-13].

Figure 20-41-14

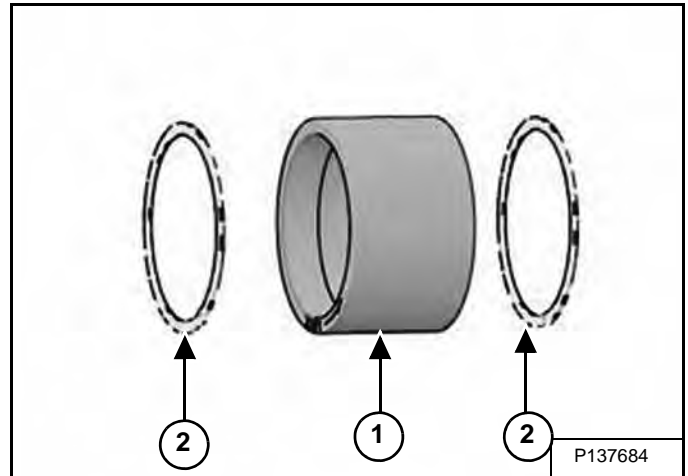

Verify there are no binding or rough spots. If problems are noted, replace one-way bearing (Item 1) and washers (Item 2) [Figure 20-41-14].

Figure 20-41-15

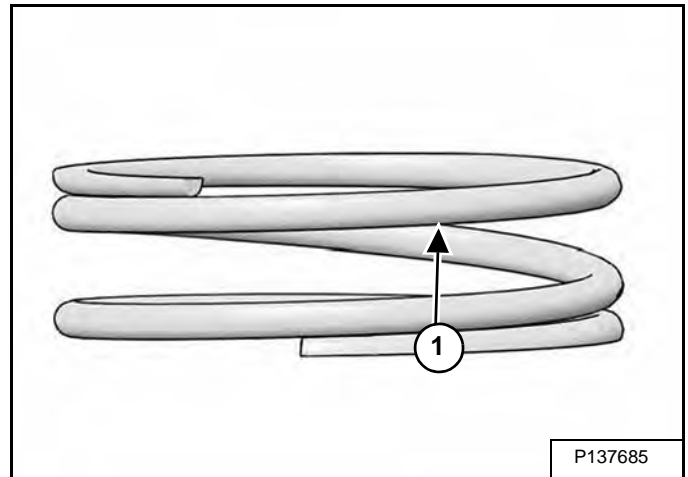

Inspect the EBS spring (plain silver painted) (Item 1) [Figure 20-41-15].

Measure the free length of the spring and compare to specifications. Replace if necessary.

Service Limit 17,78 mm (0.76 in)

CONTINUOUS VARIABLE TRANSMISSION (CVT) (DRIVEN CLUTCH)

Removal And Installation

Raise the cargo box.

Remove the outer CVT cover. (See CVT (Outer) Cover Removal And Installation on Page 20-40-8.)

Remove the drive belt. (See Removal on Page 20-30-1.)

Figure 20-42-1

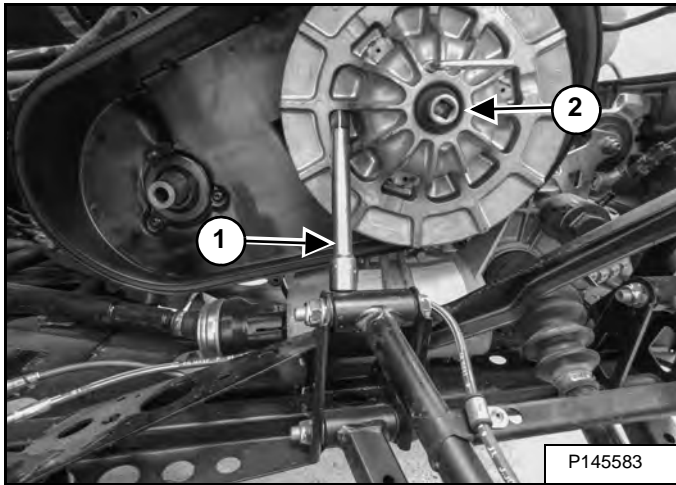

Wedge a six inch extension (Item 1) [Figure 20-42-1] between the clutch movable sheave and the A-Arm.

Remove the clutch bolt (Item 2) [Figure 20-42-1], Belleville washer and washer(s).

Remove the driven clutch

Installation: Tighten the bolt to 27 N•m (20 ft-lb) torque.

Figure 20-42-2

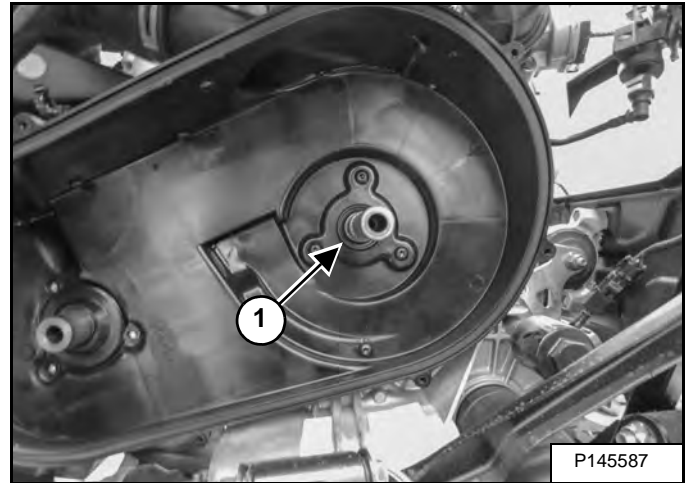

Installation: Clean the splines inside the driven clutch and on the transmission input shaft (Item 1) [Figure 20-42-2]. Apply a light film of grease to the splines on the shaft.

FINAL DRIVE (CONT'D)

Front Bearing Carrier Removal (Cont'd)

Figure 20-50-6

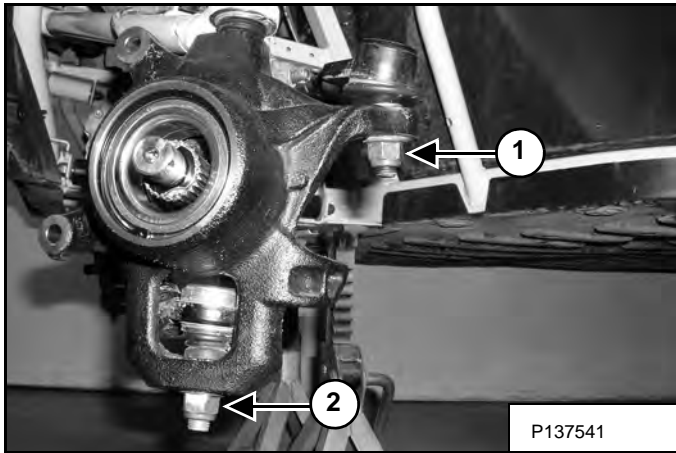

Remove the nut (Item 1) [Figure 20-50-6] retaining the tie rod end to the bearing carrier.

Remove the nut (Item 2) [Figure 20-50-6] retaining the lower ball joint to the bearing carrier.

Figure 20-50-7

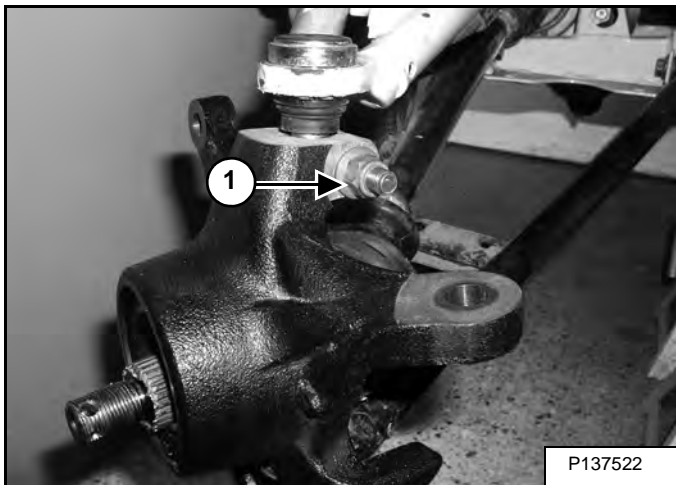

Remove the upper ball joint pinch bolts (Item 1) [Figure 20-50-7].

Using a soft faced hammer, lightly tap the bearing carrier while removing the upper and lower ball joints ends from the bearing carrier.

Pull the bearing carrier out to remove it from the drive shaft.

Rotate bearing by hand and check for rough spots. The bearing should rotate quietly and smoothly with no detectable up and down movement and minimal movement sideways between the inner and outer races. Visually inspect for moisture, dirt or corrosion.

Front Bearing Removal And Installation

Removal

Figure 20-50-8

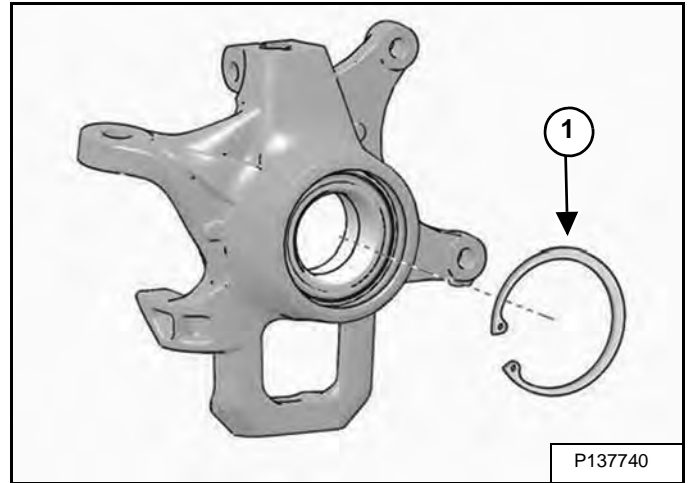

Remove the outer snap ring (Item 1) [Figure 20-50-8].

Figure 20-50-9

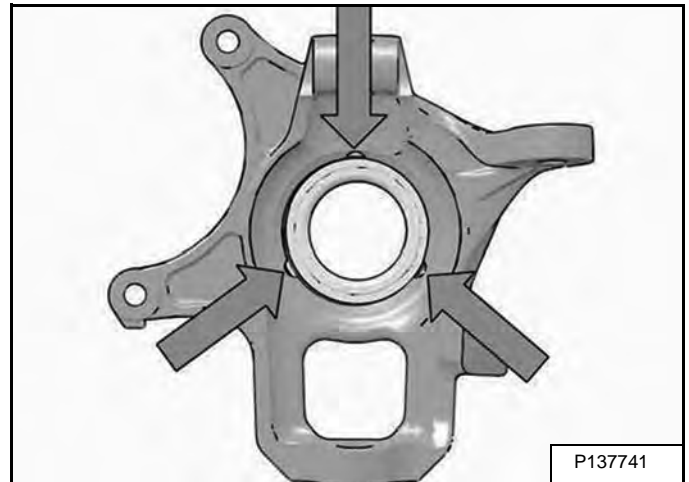

From back side of the bearing carrier, tap on the outer bearing race with a drift punch in the reliefs as shown [Figure 20-50-9].

Drive bearing out evenly by tapping on outer race only. Once bearing is at bottom of casting, support casting on outer edges so bearing can be removed.

Inspect bearing carrier housing for scratches, wear or damage. Replace front bearing carrier if damaged.

FINAL DRIVE (CONT'D)

Rear Drive Shaft Removal And Installation

Lift and block the machine. (See Procedure on Page 10-10-1.)

Remove the rear wheels. (See Wheel Removal And Installation on Page 10-120-2.)

Remove the rear bearing carrier. (See Rear Carrier Bearing Removal on Page 20-50-8.)

Figure 20-50-37

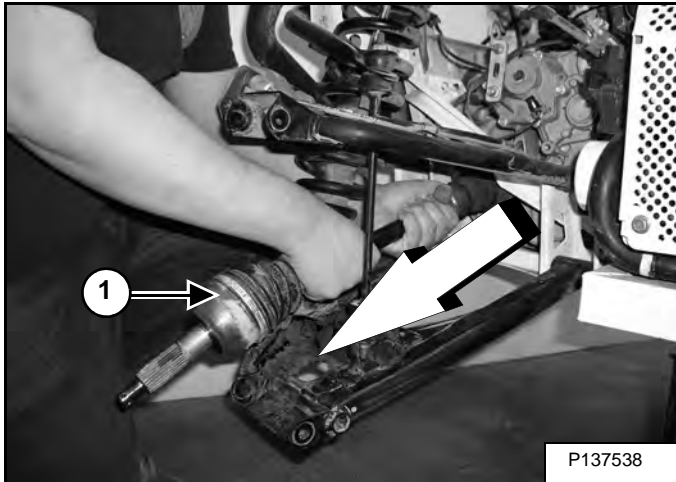

With a short, sharp jerky move, remove the drive shaft (Item 1) [Figure 20-50-37].

Figure 20-50-38

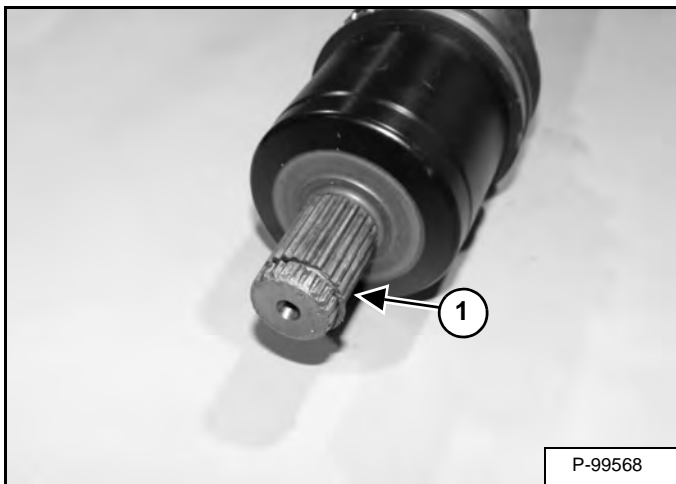

Installation: Install a new spring ring (Item 1) [Figure 20-50-38] on the end of the drive shaft. Apply an anti-seize compound to the splines.

Align the splines of the drive shaft with the transmission and reinstall the drive shaft. Use a rubber mallet to tap on the outboard end of the drive shaft in necessary.

Drive Shaft / CV Joint Handling

Care should be exercised during drive shaft removal or when servicing CV joints. Drive shaft components are precision parts.

Cleanliness and following these instructions is very important to ensure proper shaft function and a normal service life.

- The complete drive shaft and joint should be handled by getting hold of the interconnecting shaft to avoid disassembly or potential damage to the drive shaft joints.
- Over-angling of joints beyond their capacity could result in boot or joint damage.
- Make sure surface-ground areas and splines of shaft are protected during handling to avoid damage.
- Do not allow boots to come into contact with sharp edges or hot engine and exhaust components.
- The drive shaft is not to be used as a lever arm to position other suspension components.
- Never use a hammer or sharp tools to remove or to install boot clamps.
- Be sure joints are thoroughly clean and that the proper amount and type of grease is used to refill when joint boots are replaced and when joints are cleaned. Refer to text for grease capacity of CV joints and CV joint boots.

FINAL DRIVE (CONT'D)

Prop Shaft Removal And Installation (Cont'd)

UV34XL Rear

Remove the rear floor panels. (See UV34XL on Page 30-200-4.)

Remove the air ducts. (See UV34 And UV34XL Rear Removal And Installation on Page 30-210-1.)

Remove the inner CVT cover. (See CVT (Inner) Cover Removal And Installation on Page 20-40-8.)

Figure 20-50-65

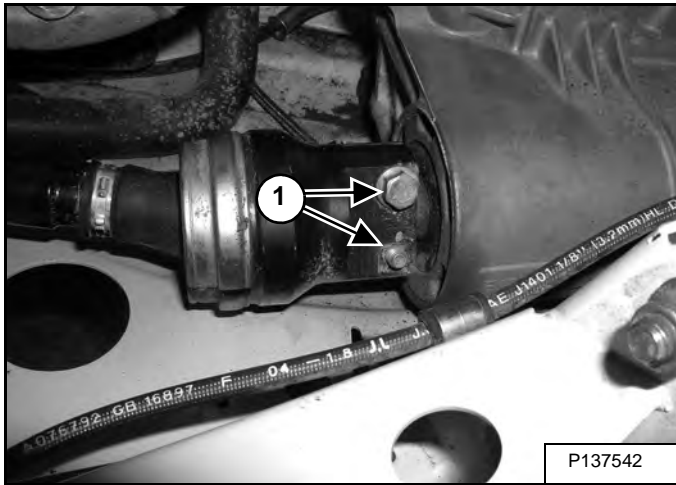

Remove the bolts (Item 1) [Figure 20-50-65] securing the prop shaft to the transmission.

Installation: Tighten the bolts to 54N•m (40 ft-lb) torque.

Figure 20-50-66

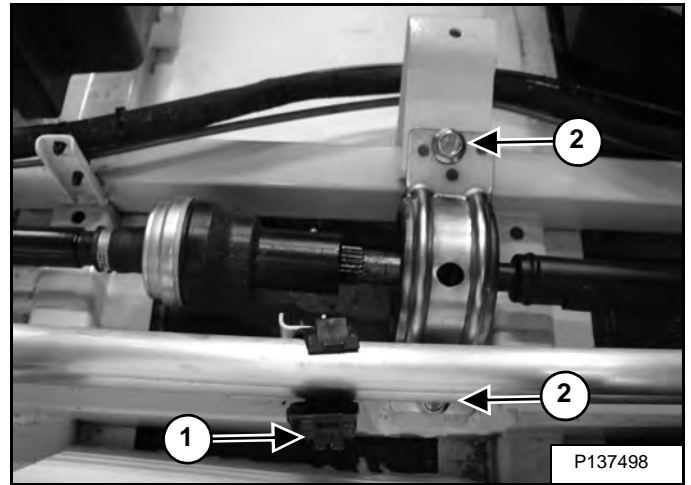

Remove the screws (Item 1) [Figure 20-50-66] from the coolant lines bracket to access hanger bearing bolts.

Installation: Tighten the screws to 5 N•m (44 in-lb) torque.

Remove the hanger bearing bolts (Item 2) [Figure 20-50-66].

Installation: Tighten the bolts to 54N•m (40 ft-lb) torque.

Figure 20-50-67

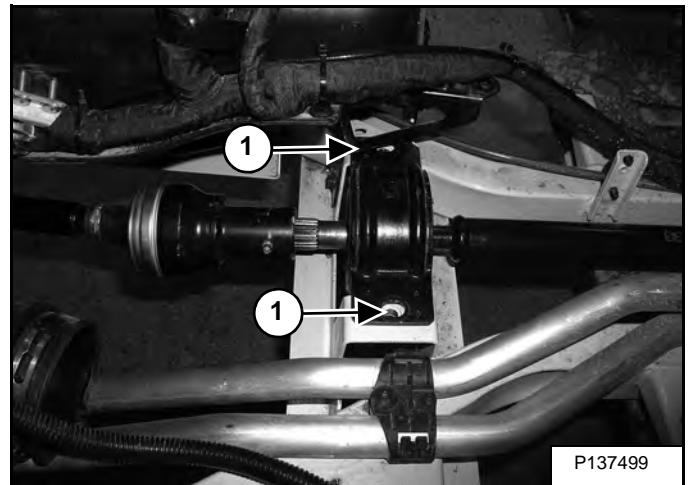

Remove the hanger bearing bolts (Item 1) [Figure 20-50-67].

Remove the rear prop shaft.

FINAL DRIVE (CONT'D)

Front Gearcase Disassembly / Inspection (Cont'd)

Figure 20-50-90

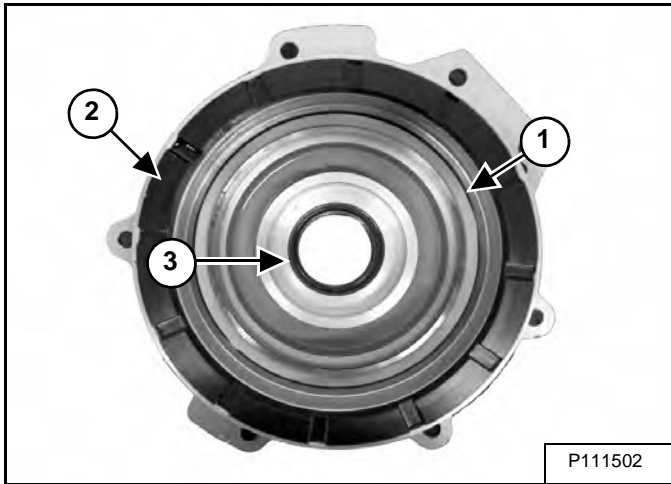

Inspect the AWD coil (Item 1) [Figure 20-50-90] located in the outer cover plate assembly. Refer to “AWD Diagnosis” for detailed inspection process.

Replace the cover plate seal (Item 2) and O-ring (Item 3) [Figure 20-50-90].

Figure 20-50-91

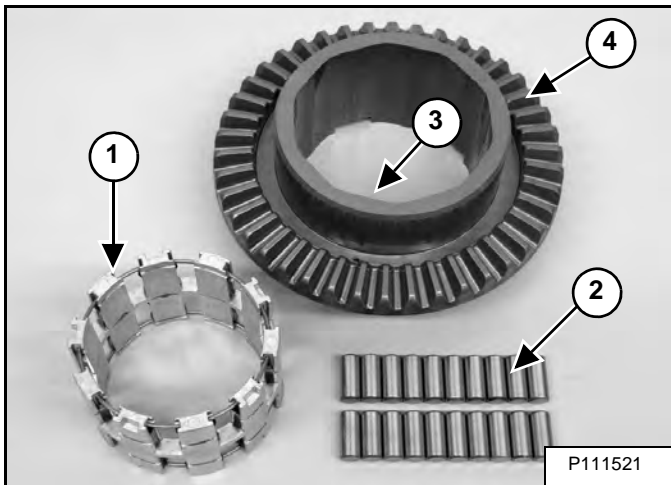

Remove the roll cage assembly (Item 1) and rollers (Item 2) from the clutch housing (Item 3) [Figure 20-50-91]. Use a shop towel to cover the housing in order to retain all the rollers.

NOTE: Rollers are spring loaded. Take care not to allow them to fall out or lose them upon removal of the roll cage.

Thoroughly clean all parts and inspect the rollers (Item 2) [Figure 20-50-91] for nicks and scratches. The rollers must slide up and down and in and out freely within the roll cage sliding surfaces and H-springs.

Inspect the clutch housing ring gear (Item 4) [Figure 20-50-91] for a consistent wear pattern and chipped, broken or missing teeth.

Figure 20-50-92

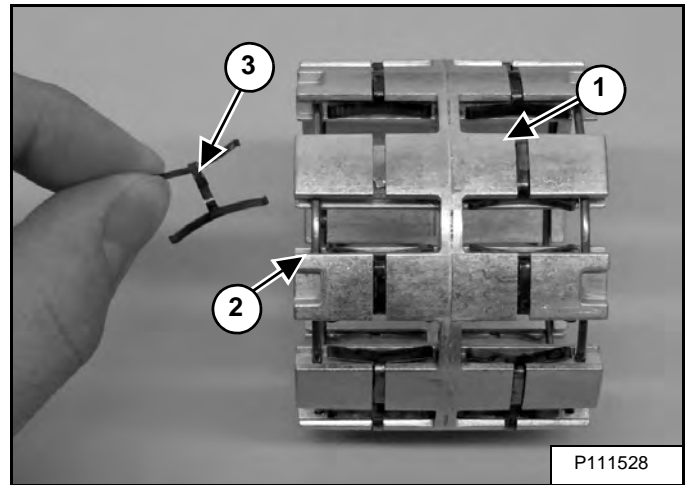

Inspect the roll cage assembly (Item 1) sliding surfaces (Item 2) and H-springs (Item 3) [Figure 20-50-92]. The sliding surfaces must be clean and free of nicks, burrs or scratches. If damaged, replace the roll cage assembly.

Figure 20-50-93

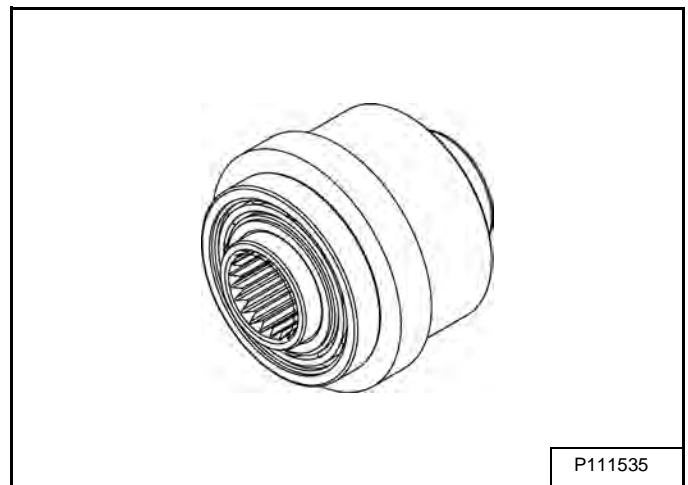

Inspect both output hub assemblies. Inspect the bearings and replace if needed [Figure 20-50-93].

ROLL OVER PROTECTIVE STRUCTURE (ROPS) (CONT'D)

Removal And Installation (Cont'd)

UV34 (Cont'd)

Figure 30-10-8

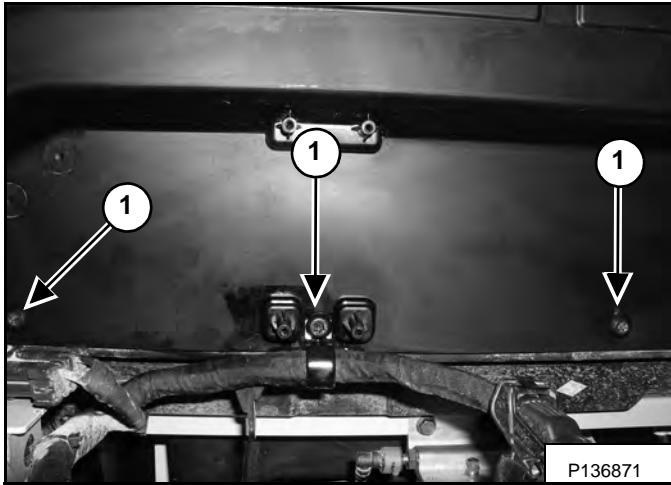

Figure 30-10-9

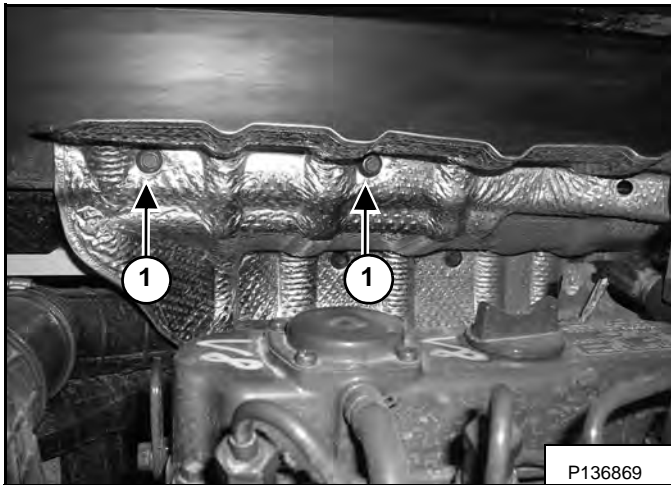
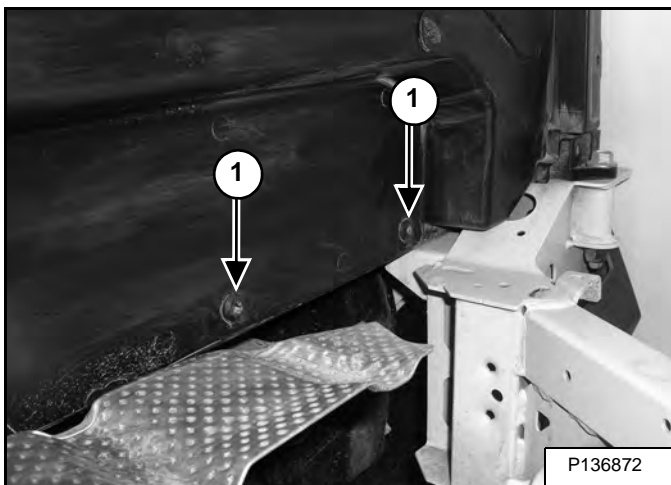
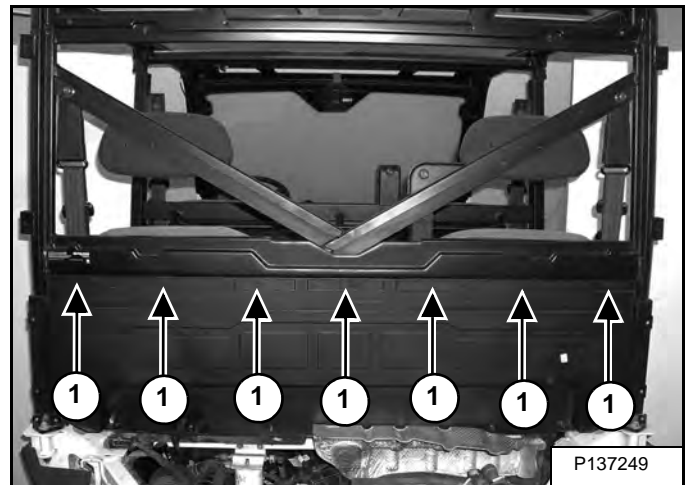

Figure 30-10-10



Remove the screws (Item 1) [Figure 30-10-8], [Figure 30-10-9] and [Figure 30-10-10] from the rear panel.

Figure 30-10-11



Remove the plastic rivets (Item 1) [Figure 30-10-11] and remove the rear panel.

Figure 30-10-12

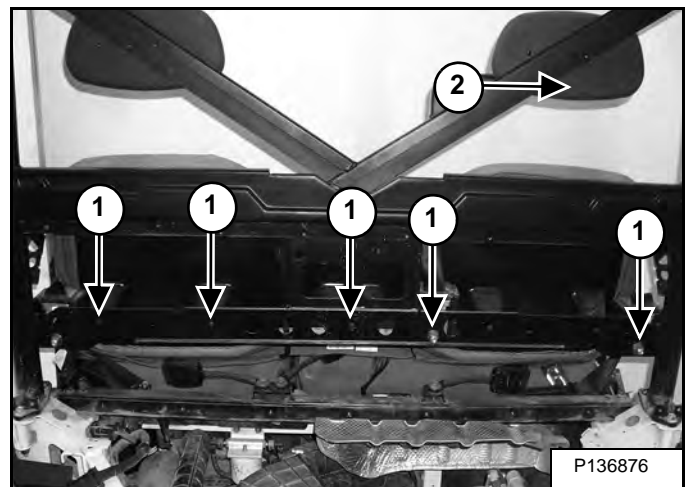

Remove the screws (Item 1) [Figure 30-10-12] securing the seat back to the cab frame.

Remove the seat back.

SEAT (CONT'D)

Seat Plate Removal And Installation (Cont'd)

Figure 30-20-10

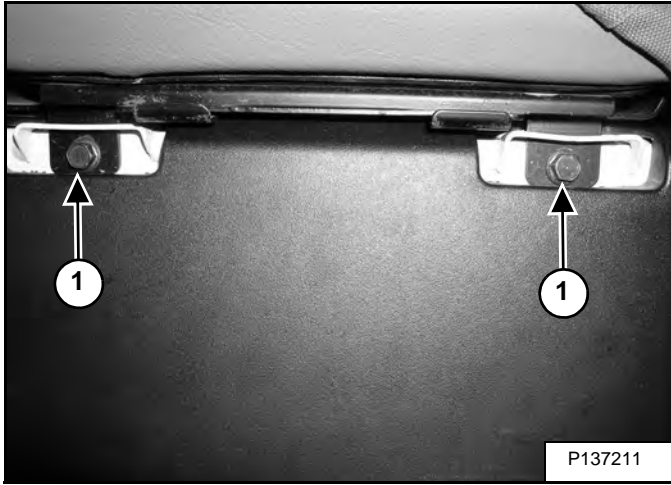

Remove the screws (Item 1) [Figure 30-20-10] from the front of the seat frame.

Remove the seat plate.

Operator Seat Base Removal And Installation

UV34 And UV34XL Rear Seat

Seat base removal and installation procedures are covered in fuel tank removal and installation. (See Removal And Installation on Page 30-80-1.)

Passenger Seat Base Removal And Installation

UV34 And UV34XL Rear Seat

Figure 30-20-11

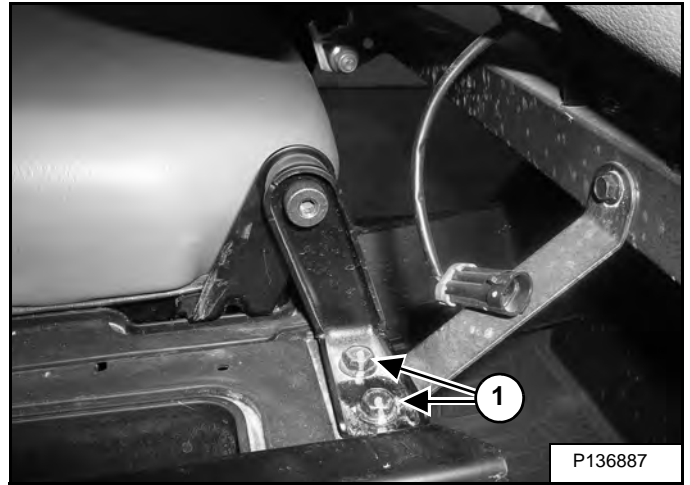

Tilt the seat bottom forward.

Remove the screws (Item 1) [Figure 30-20-11].

Figure 30-20-12

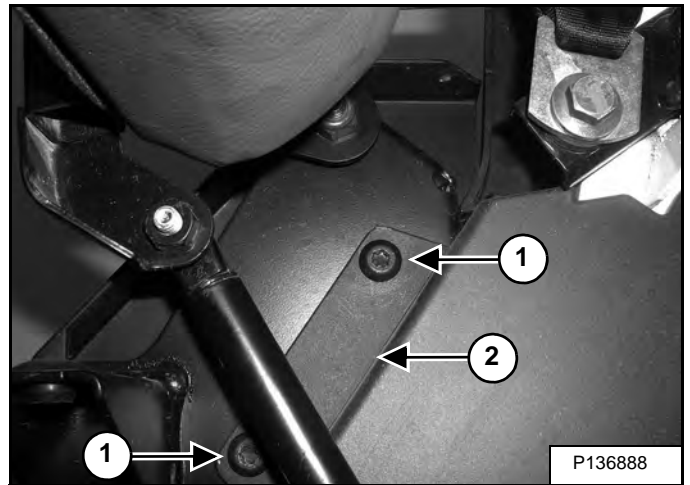

Remove the screws (Item 1) and cover (Item 2) [Figure 30-20-12].

DASH (CONT'D)

Instrument Cluster Cover Removal And Installation

Figure 30-30-18

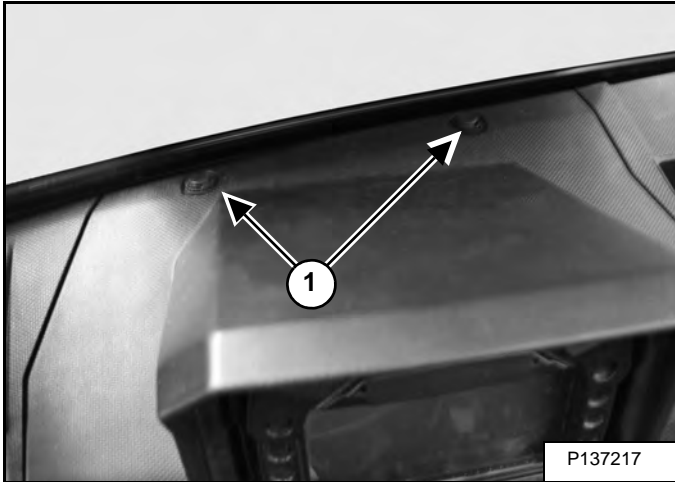

Remove the plastic rivets (Item 1) [Figure 30-30-18].

Figure 30-30-19

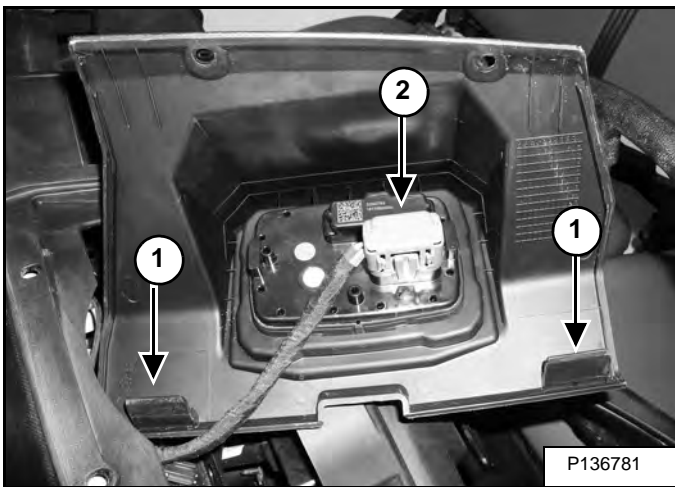

Slide the cluster rearward to disengage tabs (Item 1) [Figure 30-30-19].

Disconnect the harness (Item 2) [Figure 30-30-19] from the back of the instrument cluster.

Remove the instrument cluster cover.

Upper Center Storage Cover Removal And Installation

Figure 30-30-20

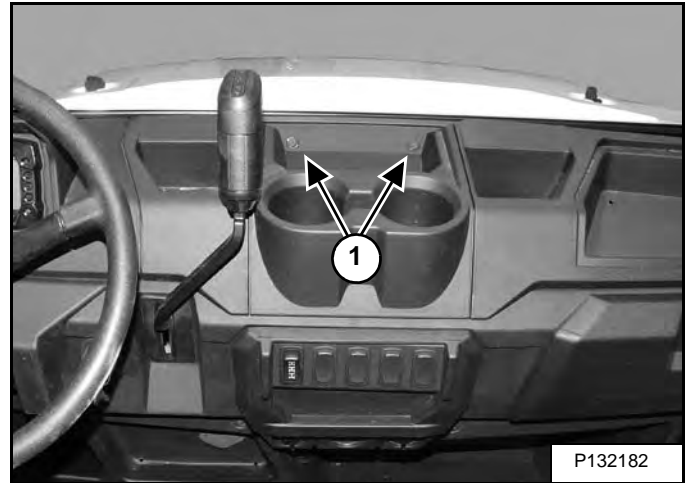

Remove the two plastic rivets (Item 1) [Figure 30-30-20] and remove the cover.

STEERING COLUMN (CONT'D)

Steering Wheel / Upper Steering Shaft Removal And Installation (Cont'd)

Figure 30-60-8

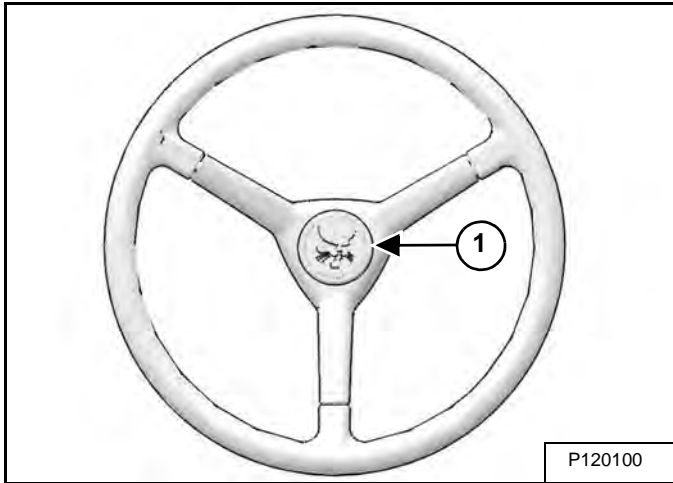

Remove the steering wheel cap (Item 1) **[Figure 30-60-8]**.

Loosen the nut and back it half way off the steering shaft.

Place the assembly in a vise.

Using a large bronze drift and hammer, strike steering shaft nut to pop the steering wheel off the tapered shaft.

Once the steering wheel pops loose, completely remove the nut and lift the steering wheel off the shaft.

FUEL TANK (CONT'D)

Removal And Installation (Cont'd)

Figure 30-80-9

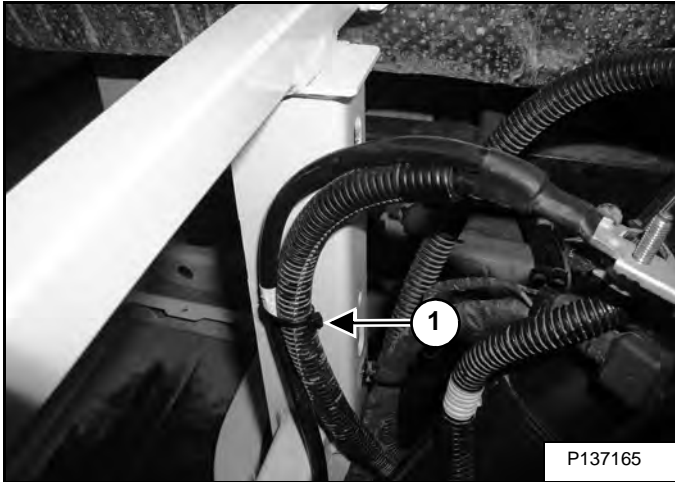

Remove the tie strap (Item 1) [Figure 30-80-9].

Figure 30-80-10

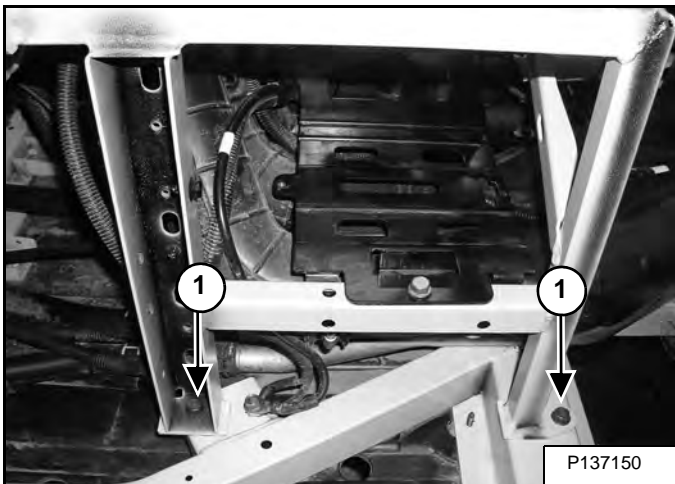

Remove the screws (Item 1) [Figure 30-80-10] from the seat base.

Figure 30-80-11

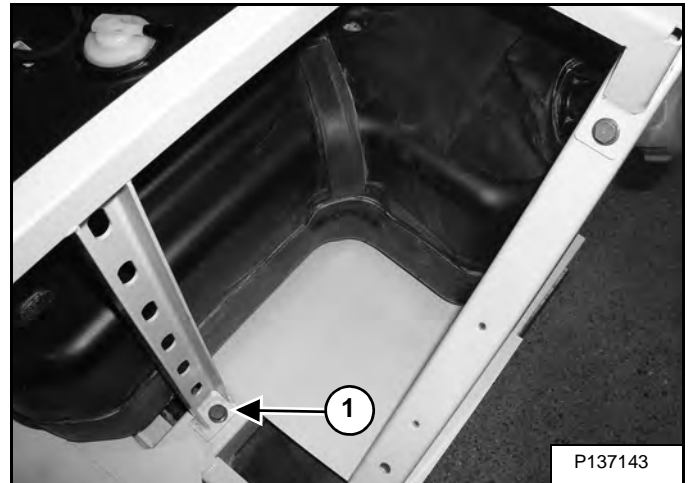

Remove the screw (Item 1) [Figure 30-80-11] from the seat base.

Remove the seat base.

Figure 30-80-12

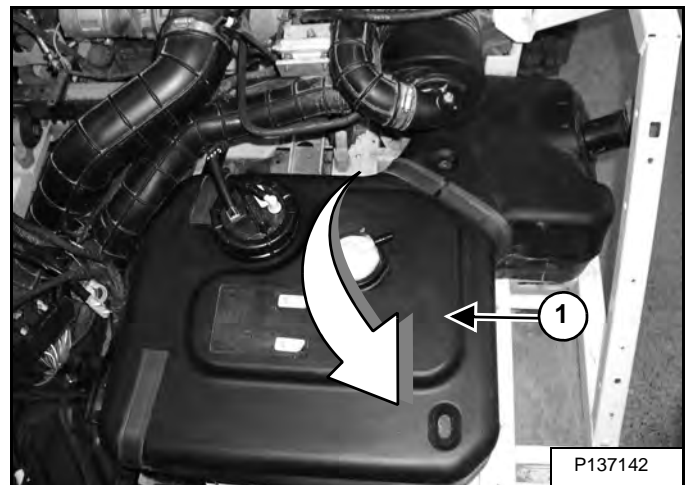

Rotate and remove the fuel tank (Item 1) [Figure 30-80-12].

A-ARMS (CONT'D)

Front Upper A-Arm Installation (Cont'd)

Figure 30-100-14

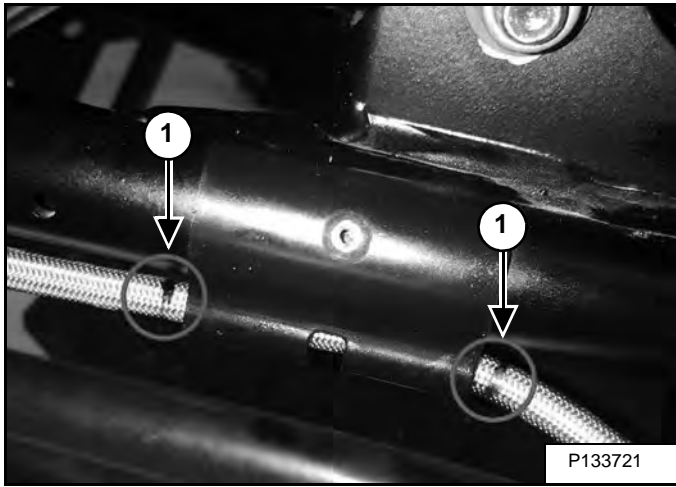

Verify the alignment marks (Item 1) [Figure 30-100-14] are visible on both sides of the clamps.

Figure 30-100-15

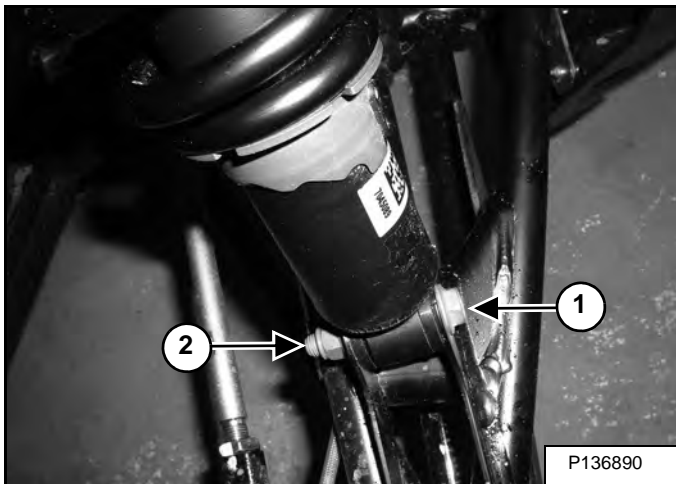

Install the shock mount bolt (Item 1) and nut (Item 2) [Figure 30-100-15].

Tighten the nut to 54 N•m (40 ft-lb) torque.

Figure 30-100-16

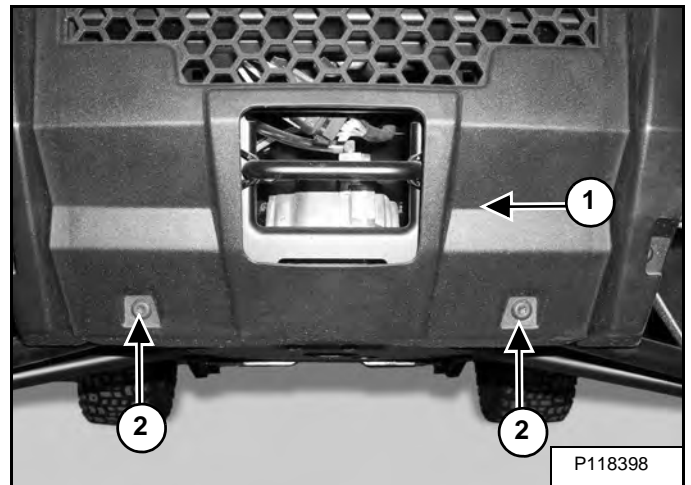

Position the front fascia (Item 1) and install the screws (Item 2) [Figure 30-100-16].

Install the tire assembly. (See Wheel Removal And Installation on Page 10-120-2.)

CLICK HERE TO **DOWNLOAD** THE COMPLETE MANUAL

- Thank you very much for reading the preview of the manual.
- You can download the complete manual from: www.heydownloads.com by clicking the link below



- Please note: If there is no response to CLICKING the link, please download this PDF first and then click on it.

CLICK HERE TO **DOWNLOAD** THE COMPLETE MANUAL

TIE ROD

Description

The tie rods are the adjustable connection that links the steering cylinder shaft to the spindle. The tie rods provide a method of adjusting the “toe” position of the wheels.

Removal And Installation

Lift and block the machine. (See Procedure on Page 10-10-1.)

Remove the tire assembly. (See Wheel Removal And Installation on Page 10-120-2.)

NOTE: The tie rod end and boot are serviceable, when replacing a tie rod, the tie rod must be replaced as a complete unit. After the tie rod is replaced, the wheel alignment for toe position must be checked.

Figure 30-110-1

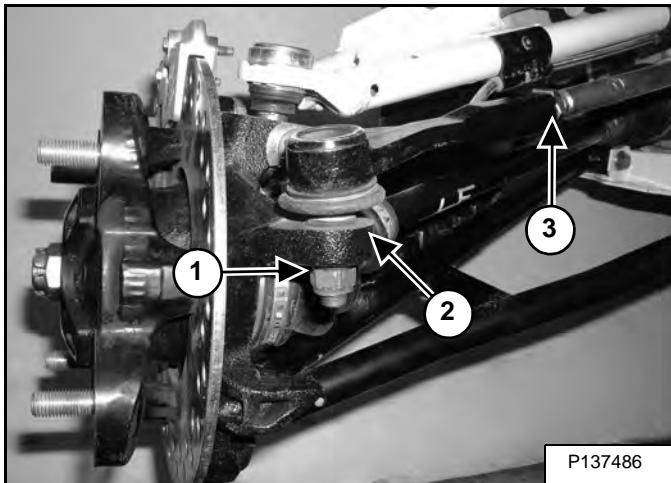

Remove the nut (Item 1) and separate the outer tie rod end from the spindle (Item 2) [Figure 30-110-1].

Installation: Tighten the nut to 41 N•m (30 ft-lb) + 90° torque.

Loosen the nut (Item 3) [Figure 30-110-1] and turn the tie rod end off of the tie rod. Count the number of turns it takes to remove the tie rod end.

Installation: Turn the new tie rod end onto the tie rod the same number of turns it took to remove the old tie rod end. Tighten the nut to 18 N•m (13 ft-lb) torque.

FENDER (CONT'D)

Fender Flare Removal And Installation

NOTE: Left flare shown. Procedures are the same for the right side.

Figure 30-140-8

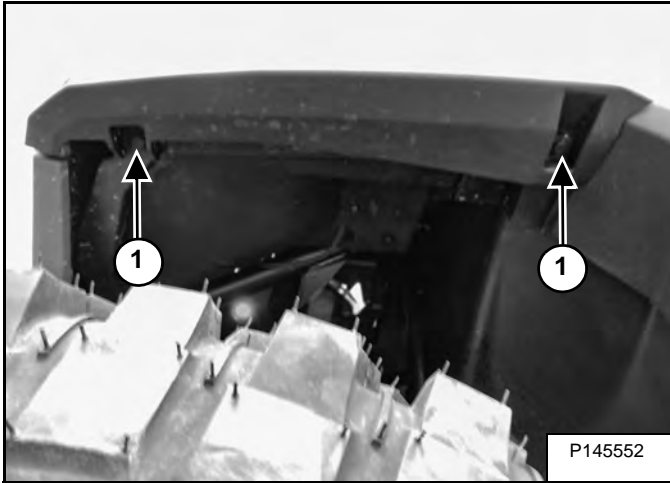

Remove the two plastic rivets (Item 1) [Figure 30-140-8] from the underside of the fender flare.

Figure 30-140-9

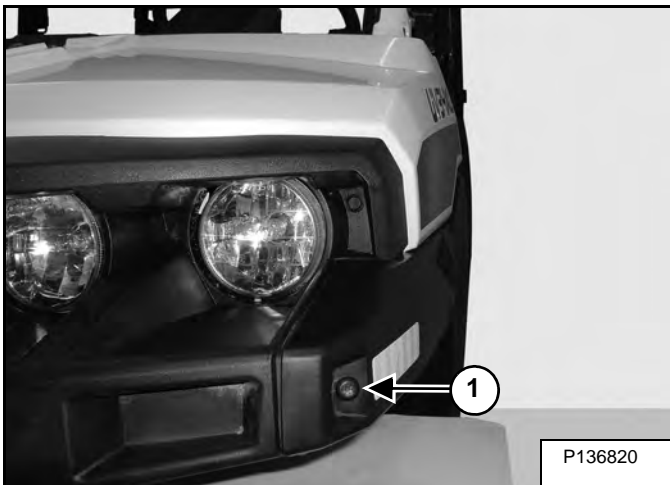

Remove the screw (Item 1) [Figure 30-140-9].

Slide the fender flare forward to disengage the tabs from the fender.

DOOR LATCH

Removal And Installation

Figure 30-170-1

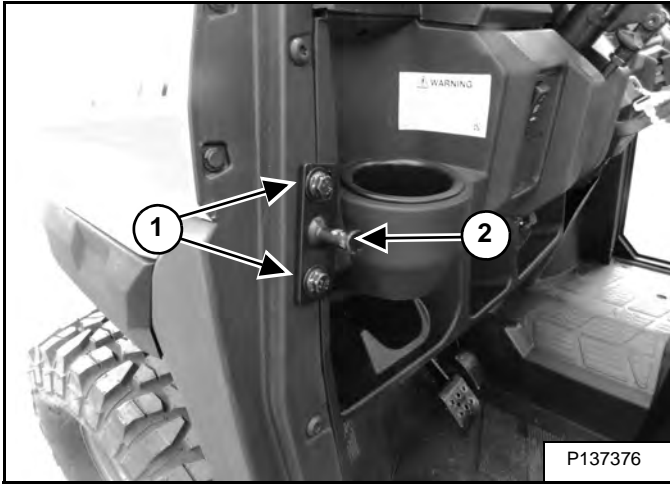

Remove the bolts (Item 1) and striker (Item 2) [Figure 30-170-1].

Adjustment

Figure 30-170-2

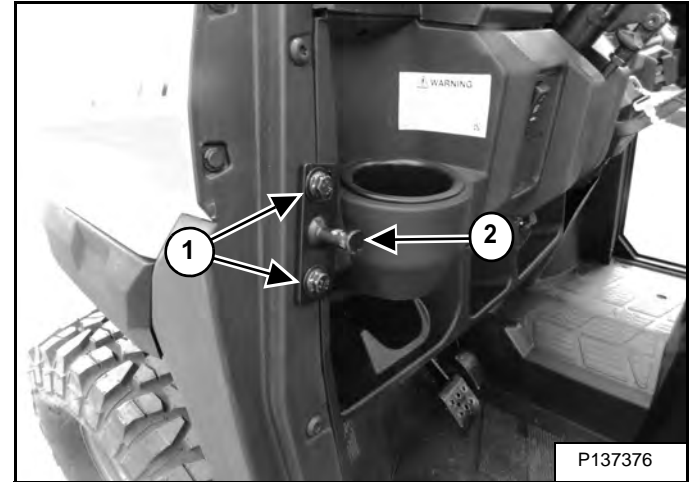

Loosen the two bolts (Item 1) and move the striker (Item 2) [Figure 30-170-2]. It may take several attempts to get the striker properly aligned.

FLOORPLATE (CONT'D)

UV34 (Cont'd)

Passenger Side Removal And Installation (Cont'd)

Figure 30-200-9

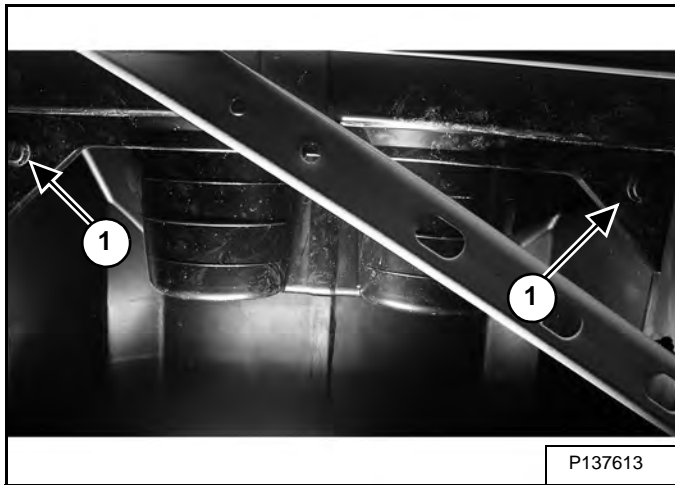

Remove the rivets (Item 1) [Figure 30-200-9] from the back of the tunnel cover.

Remove the tunnel cover.

Figure 30-200-10



Remove the plastic rivet (Item 1) [Figure 30-200-10].

Figure 30-200-11

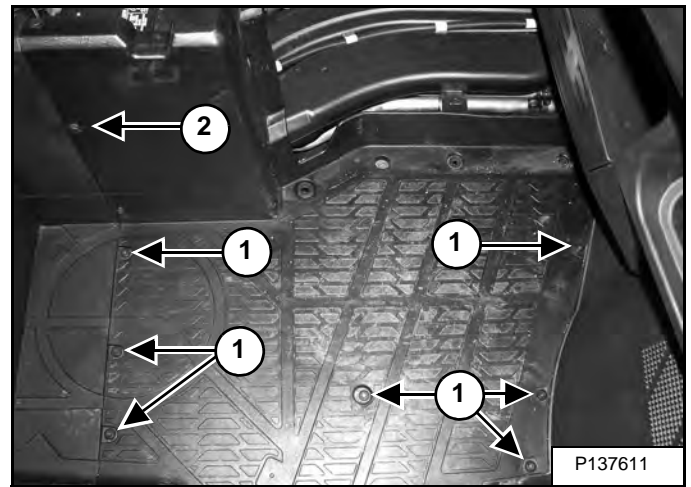

Remove the screws (Item 1) and plastic rivet (Item 2) [Figure 30-200-11].

Figure 30-200-12

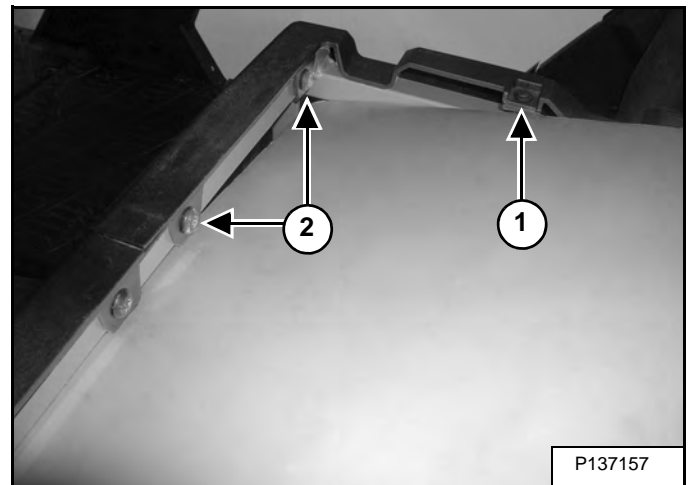

Remove the rivet (Item 1) and screws (Item 2) [Figure 30-200-12].

Installation: Tighten the screws to 5 N•m (42 in-lb) torque.

Remove the passenger side floorplate.

AIR DUCTING (CONT'D)

UV34 And UV34XL Rear Removal and Installation (Cont'd)

Figure 30-210-9

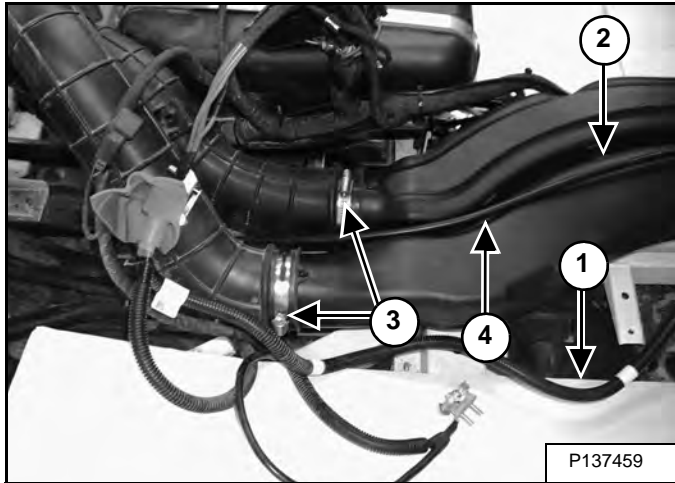

Remove the harness (Item 1) and shift cable (Item 2) [Figure 30-210-9] from the ducting.

Loosen the hose clamps (Item 3) [Figure 30-210-9].

Reposition the harness (Item 4) [Figure 30-210-9] and shift cable.

UV34

Figure 30-210-10

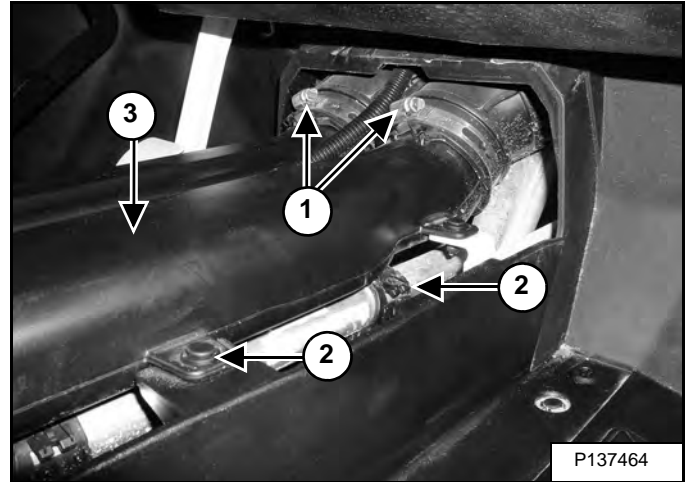

Loosen the clamps (Item 1) [Figure 30-210-10].

Remove the rivets (Item 2) and remove the ducting (Item 3) [Figure 30-210-10].

UV34XL

Figure 30-210-11

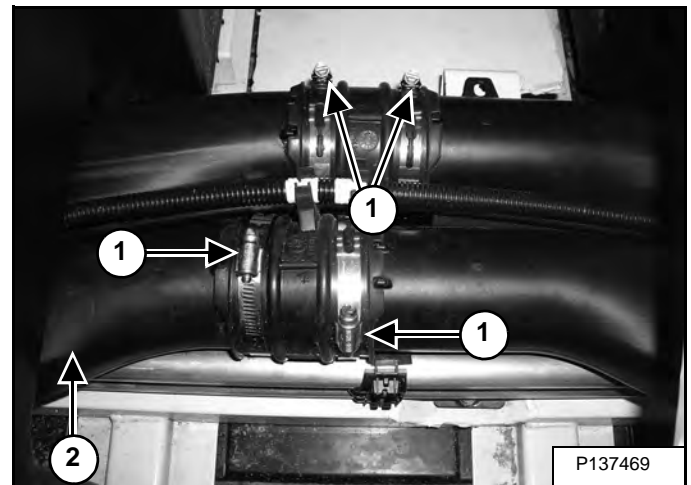

Loosen the clamps (Item 1) and remove the ducting (Item 2) [Figure 30-210-11].

ELECTRICAL SYSTEM INFORMATION (CONT'D)

Troubleshooting

The following troubleshooting chart is provided for assistance in locating and correcting problems. Many of the recommended procedures must be done by authorized Bobcat Service Personnel only.



WARNING

Instructions are necessary before operating or servicing machine. Read and understand the Operation & Maintenance Manual and signs (decals) on machine. Follow warnings and instructions in the manuals when making repairs, adjustments or servicing. Check for correct function after adjustments, repairs or service. Untrained operators and failure to follow instructions can cause injury or death.

W-2408-0801

PROBLEM	CAUSE
Battery will not take a charge.	1, 2, 3, 4
Stator will not charge.	1, 3, 4
Starter will not turn the engine.	1, 2, 3, 5, 6, 7, 8

KEY TO CORRECT THE CAUSE

	1. Battery connections are dirty or loose.
	2. Battery is damaged.
	3. The cable and wire connection are not making good contact.
	4. The starter / alternator is damaged.
	5. The engine is locked.
	6. The starter is damaged.
	7. The wiring or solenoid is damaged.
	8. Check the fuses.



Bobcat®

LIGHTS (CONT'D)

Headlight Adjustment

Figure 40-60-3

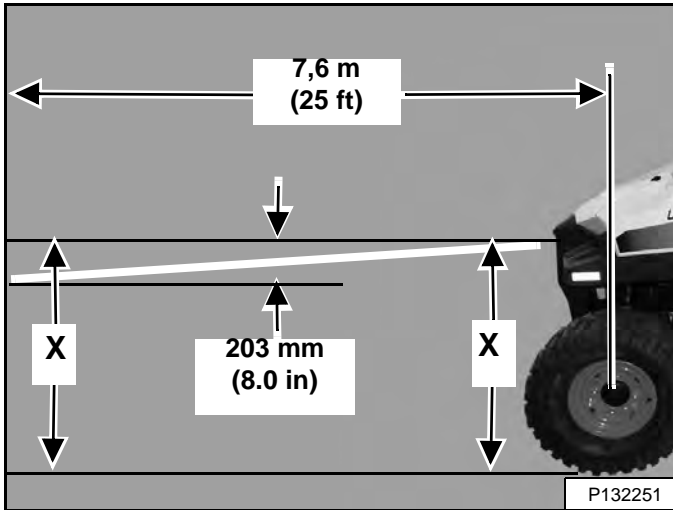

When performing the headlight adjustment procedure, there should be both an operator and passenger(s) in the seat(s) for correct beam adjustment to simulate actual vehicle operation [Figure 40-60-3]. (If using an attachment for extended lengths of time, the attachment should also be installed before adjusting lights. When the attachment is removed, the lights will need to be readjusted.)

Place the vehicle on a flat and level surface with the headlight approximately 7,6 m (25 ft) from a wall.

Move the gear selector lever to PARK, stop the engine and exit the vehicle.

Measure the distance (X) from the floor to the center of the headlight. On the wall, directly in front of the vehicle, make a mark (X) on the wall at the same height.

The most intense part of the light should be aimed approximately 254 mm (10.0 in) for low beam, 152 mm (6.0 in) for high beam, below the (X) mark placed on the wall.

Remove the front access cover. (See Front Access Cover Removal And Installation on Page 30-30-1.)

Figure 40-60-4

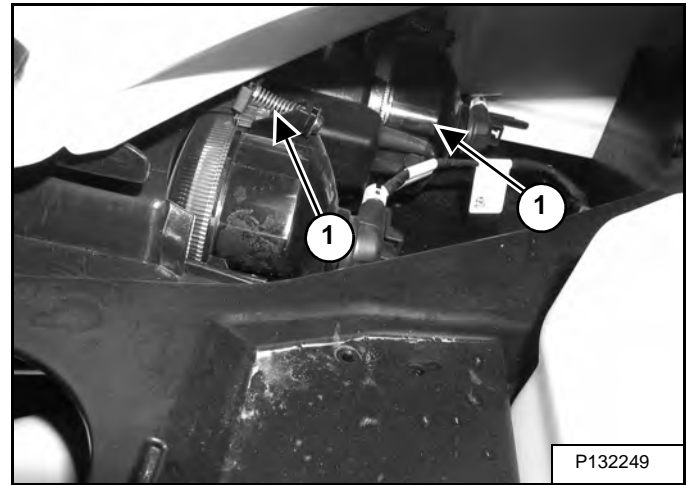

Locate the headlight adjusting screw (Item 1) [Figure 40-60-4] on the headlight housing (one adjusting screw for each light). The high beam light bulb is to the inside and the low beam light bulb is to the outside (both sides).

Rotate the screw in or out as needed to adjust the headlight.

Repeat until the headlights are in correct adjustment.

Reinstall the front access cover.

ELECTRONIC FUEL INJECTION SENSORS (CONT'D)

Engine Coolant Temperature Sensor (Cont'd)

Using an ohmmeter, measure the resistance between the two sensor terminals.

TEMPERATURE °F (°C)	RESISTANCE
68 °F (20 °C)	2.5k Ω . \pm 6%
86 °F (30 °C)	1.7k Ω . \pm 6%
104 °F (40 °C)	1.2k Ω . \pm 6%
122 °F (50 °C)	834 Ω . \pm 6%
140 °F (60 °C)	596 Ω . \pm 6%
158 °F (70 °C)	435 Ω . \pm 6%
176 °F (80 °C)	323 Ω . \pm 6%
194 °F (90 °C)	243 Ω . \pm 6%
212 °F (100 °C)	186 Ω . \pm 6%

Removal And Installation

Raise the cargo box.

Remove the Intake Manifold. (See Engine Coolant Temperature Sensor (ECT) on Page 40-90-3.)

Drain the coolant so the level is below the sensor.

Figure 40-90-8

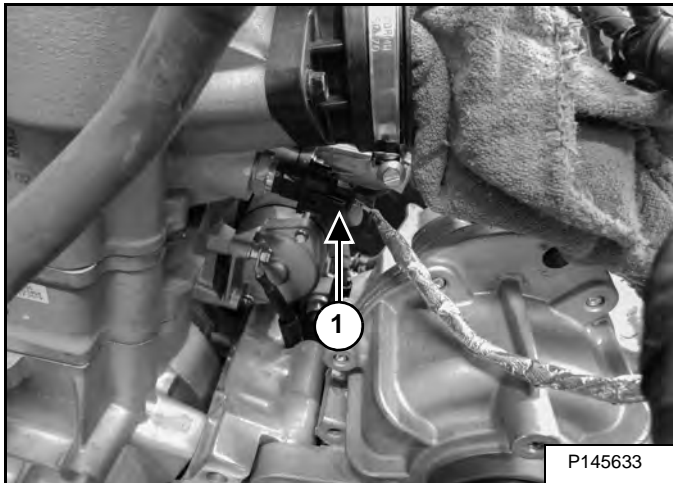

Disconnect the harness connector (Item 1) [Figure 40-90-8] from the sensor.

Figure 40-90-9

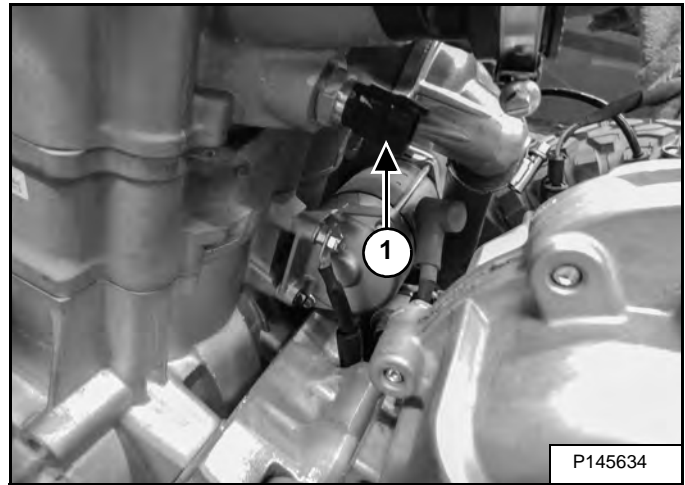

Remove the sensor (Item 1) [Figure 40-90-9].

Installation: Apply thread sealant to the new sensor threads.

Installation: Tighten the sensor to 22 N•m (16 ft-lb) torque.

SWITCH (KEY) (CONT'D)

Ignition Key Switch Testing

Disconnect the key switch harness by lifting the connector lock and pulling on the connector. Do not pull on the wiring.

Test between the three sets of outputs (OFF / ON / START). If any of the tests fail, replace ignition switch assembly.

Turn the ignition key to ON. There should be continuity between switch pins B and C.

Turn the ignition key to START. There should be continuity between switch pins B and C; A and D.

Figure 40-103-4

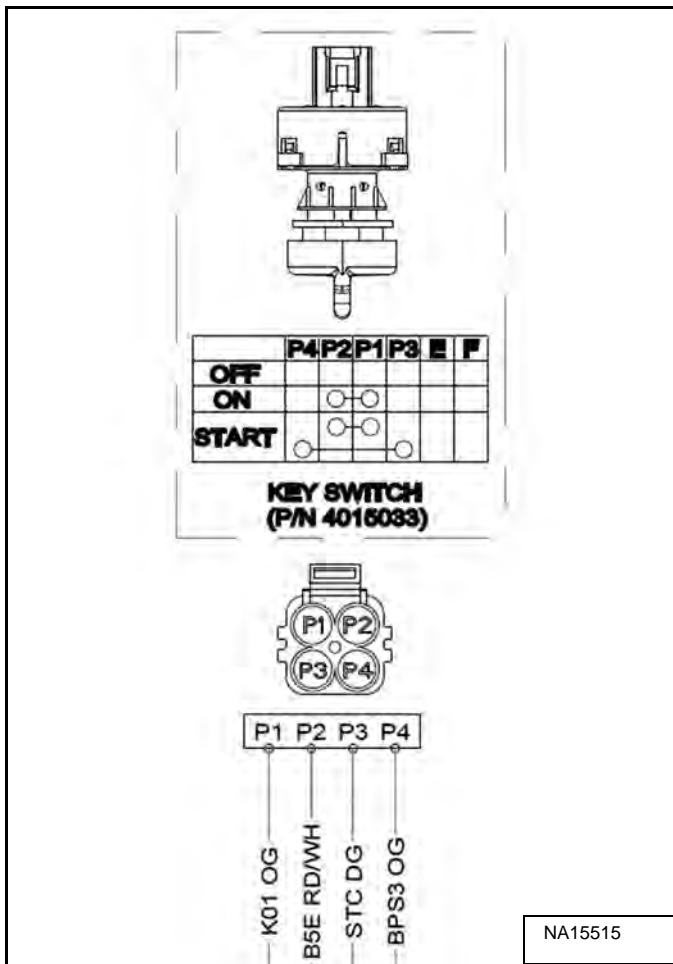

BACK-UP ALARM SYSTEM (IF EQUIPPED) (CONT'D)

Removal And Installation

Figure 40-130-4

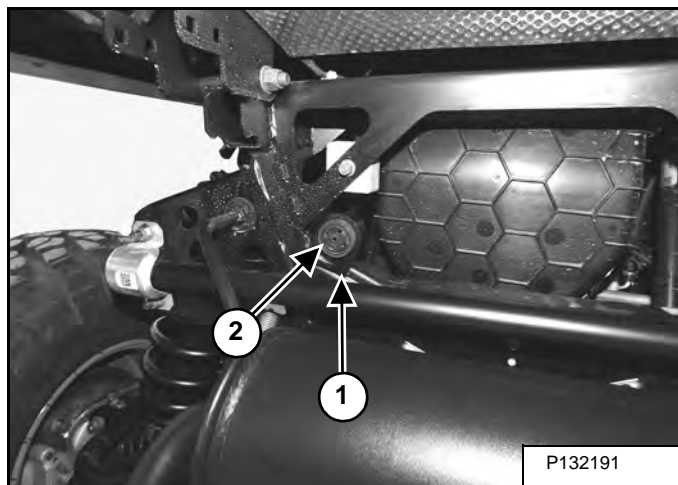

Disconnect the back-up alarm electrical connector from the main harness.

Remove the nut (Item 1) and remove the back-up alarm (Item 2) **[Figure 40-130-4]** from the vehicle.

INSTRUMENTATION CLUSTER (CONT'D)

Diagnostic Trouble Codes

COMPONENT	CONDITION	SPN	FMI	DIGITAL WRENCH P-CODE
Vehicle Speed Sensor	Data Valid But Above Normal Operational Range - Most Severe Level	84	0	C1057
	Data Erratic, Intermittent Or Incorrect		2	P0503 or C1058
	Abnormal Rate Of Change		10	C1068
	Received Network Data In Error		19	C1069
Low Oil Pressure Switch Fault	Current Below Normal Or Open Circuit	100	5	P1521
	CAN Message 65390 Timeout Error		11	P0521
Engine Temperature Sensor	Voltage Above Normal, Or Shorted to High Source	110	3	P0118
	Voltage Below Normal, Or Shorted to Low Source		4	P0117
System Power (Battery Potential / Power Input)	Data Valid But Above Normal Operational Range - Most Severe Level	168	1	P1563
	Voltage Above Normal, Or Shorted to High Source		3	P0563 or C1063
	Voltage Below Normal, Or Shorted to Low Source		4	P0562 or C1062
Engine Speed	Data Erratic, Intermittent Or Incorrect	190	2	C1061
	Received Network Data In Error		19	C1066
Gear Sensor Signal	Voltage Below Normal, Or Shorted to Low Source	523	4	P0916
ECU Memory	Bad Intelligent Device Or Component	628	12	C1073
	Out Of Calibration		13	C1601
Calibration	Out Of Calibration	630	13	C1074
Rear Differential Output	Voltage Above Normal, Or Shorted to High Source	746	3	P1692
	Voltage Below Normal, Or Shorted to Low Source		4	P1693
	Current Below Normal Or Open Circuit		5	P1691
Fan Relay Driver Circuit	Voltage Above Normal, Or Shorted to High Source	1071	3	P1482
	Voltage Below Normal, Or Shorted to Low Source		4	P1483
	Current Below Normal Or Open Circuit		5	P1481
Fuel Pump Driver Circuit	Voltage Above Normal, Or Shorted to High Source	1347	3	P0232
	Voltage Below Normal, Or Shorted to Low Source		4	P0231
	Current Below Normal Or Open Circuit		5	P0230
ECU Output Supply Voltage 1	Voltage Above Normal, Or Shorted to High Source	3597	3	P16A2
	Voltage Below Normal, Or Shorted to Low Source		4	P16A1
ECU Output Supply Voltage 3	Voltage Above Normal, Or Shorted to High Source	3598	3	P16A9
	Voltage Below Normal, Or Shorted to Low Source		4	P16A8
All Wheel Drive Control Circuit (AWD)	Voltage Above Normal, Or Shorted to High Source	520207	3	P1835
	Voltage Below Normal, Or Shorted to Low Source		4	P1834
	Current Below Normal Or Open Circuit		5	P1836
Brake Failure Lamp Faults	Voltage Above Normal, Or Shorted to High Source	520214	3	C208C
	Voltage Below Normal, Or Shorted to Low Source		4	C208B
	Current Below Normal Or Open Circuit		5	C2082
Steering Over Current Shut Down	Current Above Normal Or Grounded Circuit	520221	6	C1050
	Bad Intelligent Device Or Component		12	C102E
Steering Excessive Current Error	Current Above Normal or Grounded Circuit	520222	6	C1051
Steering Torque Partial Failure	Condition Exists	520223	31	C1052

Diagnostic codes subject to change without notice.

DIAGNOSTIC TESTING (CONT'D)

Updates

NOTE: Only authorized Bobcat dealers and distributors can access the dealer website.

Figure 40-170-5

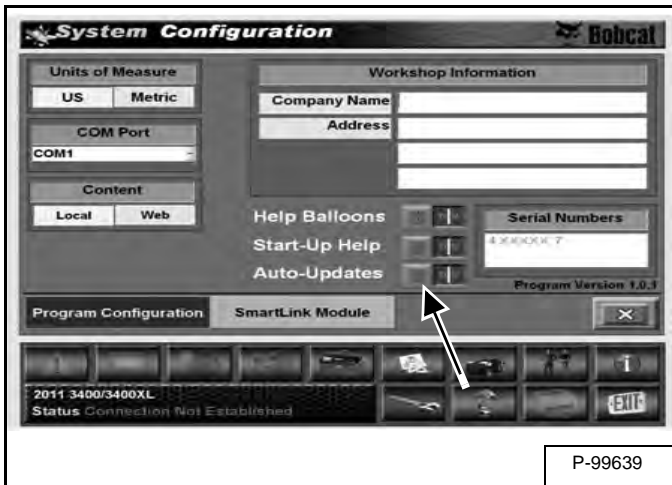

The best way to ensure that your version of Digital Wrench™ is always up to date, is by using the auto update feature. Internet access is required for this feature to work properly. Open the configuration screen by clicking on the wrench icon. Move the “Auto Updates” button to the ON (green) position [Figure 40-170-5].

If Internet access is not available, proceed to the service software page on BobcatDealerNET.com to manually check for updates.

Figure 40-170-6



Log onto BobcatDealerNET.com.

Locate the “Service Homepage” link on the main home screen [Figure 40-170-6].

Figure 40-170-7



Locate the “Service Software” link in the left margin [Figure 40-170-7].

ELECTRONIC POWER STEERING (EPS) (CONT'D)

EPS Troubleshooting (Using Digital Wrench™)

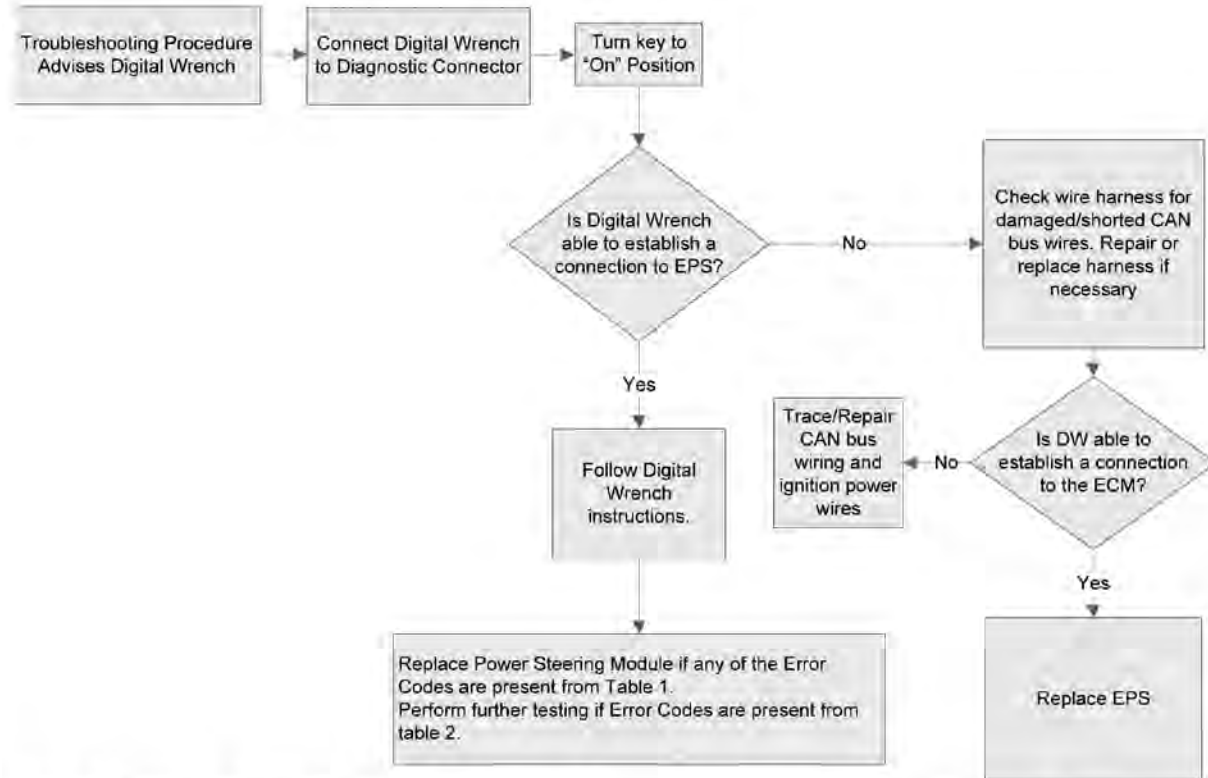

Table 1: Error Codes requiring Power Steering Replacement

1. Position Encoder Error
2. EPS Software Error
3. Steering Torque Sensor Full Failure
4. Steering Excessive Current Error*
5. Steering Over Current Shutdown*
6. Phase Sensing Over Current
7. Phase Sensing Excessive Current
8. Torque Sensor Range
9. Rotor Encoder Communication
10. Rotor Encoder Variance
11. SEPIC Voltage Low/High
12. EEPROM Failure

EPS Inverter Temperature Test:

1. Verify that Power Steering module heat sink surface (top surface) is clean and free of mud and dirt. Make a note of how much debris was on heat sink before cleaning. Record all power steering error codes and then clear all error codes. EPS inverter temperature can be monitored through Digital Wrench.
2. Allow vehicle to set and cool for at least 2 hours.
3. Drive vehicle for 30 minutes of left and right turning and then Connect Digital wrench and read Power Steering Error Codes. If Inverter Temperature Error Code is present, replace Power Steering Module. If error is not present, Module is OK. EPS inverter temperature can be checked using Digital wrench

Battery Voltage Over / Under Test:

1. Disconnect 2 pin Power Connector to EPS and verify battery voltage (12-14 VDC) is present on pins with key on. If voltage is low, investigate and correct cause. If voltage at pins is correct, check all connections for corrosion, damage, and tightness. Check pin 3 on 8 pin connector for 12V signal with key on.

*** These Error Codes must have multiple occurrences or you must be able to duplicate the condition before replacing the EPS unit.**

Table 2: Error Codes Requiring Additional Troubleshooting

1. EPS Inverter Temperature- check for mud/debris on EPS
2. Battery Voltage Over / Under- check bike's charging system and battery.
3. Calibration Error – Relfash EPS Unit

ENGINE INFORMATION (CONT'D)

Troubleshooting

ENGINE	
PROBLEM	CAUSE
Engine turns over but fails to start	No fuel
	Dirt in the fuel line or filter
	Fuel will not pass through fuel valve
	Fuel pump inoperative / restricted
	Tank vent plugged or pinched
	Engine flooded
	Low compression (high cylinder leakage)
	No spark (spark plug fouled)
	Low Battery Voltage
Engine does not turn over	Dead battery
	Starter motor does not turn
	Engine seized, rusted, or mechanical failure
Engine runs but will not idle	Restricted fuel supply
	Low compression
	Crankcase breather restricted
Engine idles but will not rev up	Spark plug fouled / weak spark
	Broken throttle cable
	Obstruction in air intake
	Air box removed (reinstall all intake components)
	Incorrect flywheel installation or sheared flywheel key
	Restricted exhaust system
	Cam worn excessively
Engine has low power	Spark plug fouled
	Cylinder, piston, ring, or valve wear or damage (check compression)
	CVT not operating properly
	Restricted exhaust muffler
	Cam worn excessively
Piston failure - Scoring	Lack of lubrication
	Dirt entering engine through cracks in air filter or ducts
	Engine oil dirty or contaminated
Excessive smoke and carbon buildup	Excessive piston-to-cylinder clearance
	Wet sumping due to over full crankcase
	Worn rings, piston or cylinder
	Worn valves, guides or seals
	Restricted breather
	Air filter dirty or contaminated
Low compression	Cylinder head gasket leak
	No valve clearance or incorrectly adjusted
	Cylinder or piston worn
	Piston rings worn, leaking, broken or sticking
	Bent valve or stuck valve
	Valve spring broken or weak
	Valve not seating properly (bent or carbon accumulated on sealing surface)
	Rocker arm sticking

ENGINE INFORMATION (CONT'D)

Engine Installation (Cont'd)

Figure 50-10-24

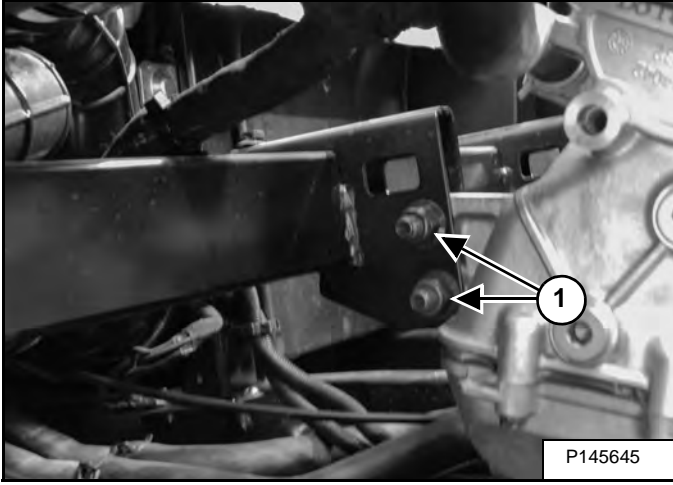

Loosely install the front engine mount bolts and nuts (Item 1) [Figure 50-10-24].

Figure 50-10-25

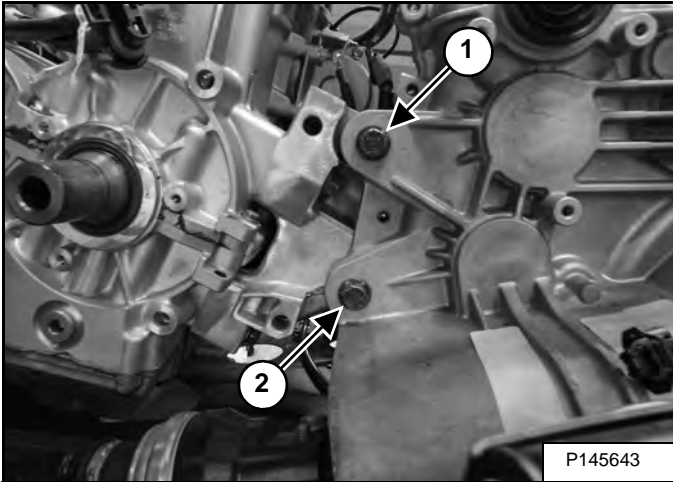

Torque the upper bolt (Item 1) [Figure 50-10-25] to 61 N•m (45 ft-lb).

Torque the lower bolt (Item 2) [Figure 50-10-25] to 61 N•m (45 ft-lb).

Figure 50-10-26

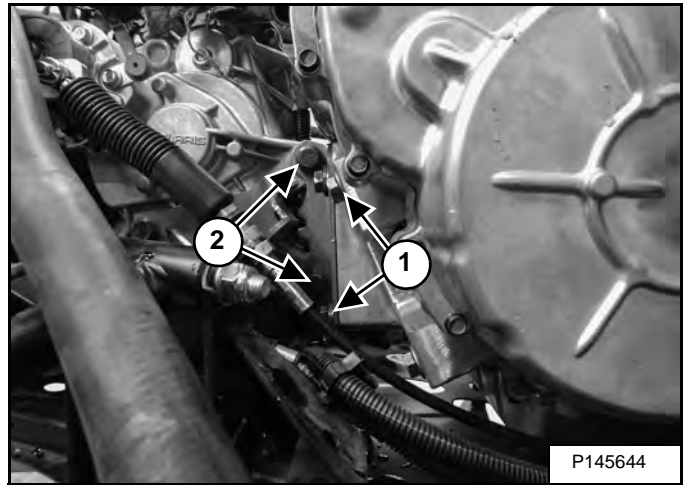

Tighten the two bolts (Item 1) [Figure 50-10-26] securing the transmission mount bracket to the engine to 7 N•m (5 ft-lb) torque.

Tighten the two bolts (Item 2) [Figure 50-10-26] securing the transmission mount bracket to the engine to 7 N•m (5 ft-lb) torque.

Figure 50-10-27

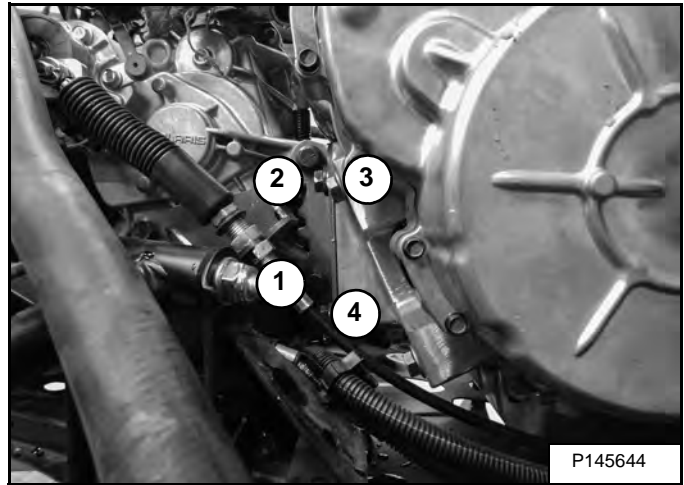

Tighten the bolts in the sequence shown in [Figure 50-10-27] to 61 N•m (45 ft-lb) torque.

ENGINE INFORMATION (CONT'D)

Front Engine Mount Removal And Installation

Use a lifting device to release the weight on the mounts.

Figure 50-10-40

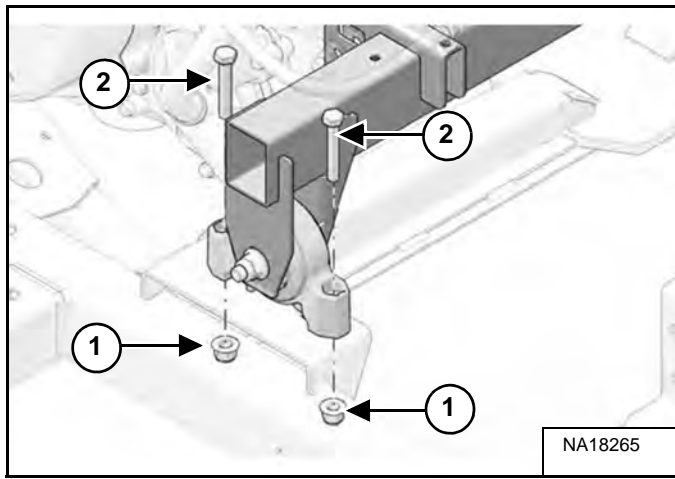

Remove the nuts (Item 1) and bolts (Item 2) **[Figure 50-10-40]**.

Installation: Tighten the nuts to 30 N•m (22 ft-lb) torque.

Figure 50-10-41

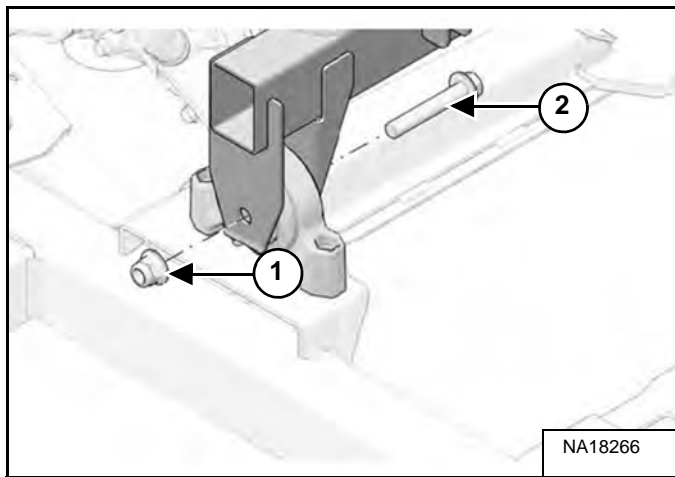

Remove the nut (Item 1) and bolt (Item 2) **[Figure 50-10-41]**.

Installation: Tighten the nuts to 54 N•m (40 ft-lb) torque.

Figure 50-10-42

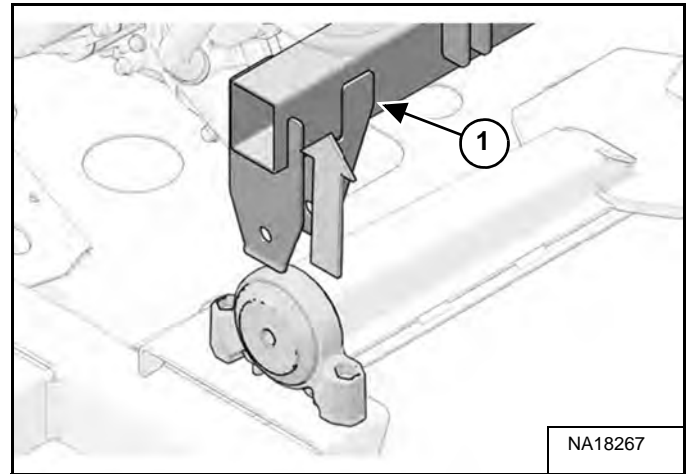

Raise the front crossmember (Item 1) **[Figure 50-10-42]** until enough clearance is gained to remove the mount from the vehicle.

INTAKE SYSTEM (CONT'D)

Air Box Removal And Installation

Raise the cargo box.

Figure 50-40-1

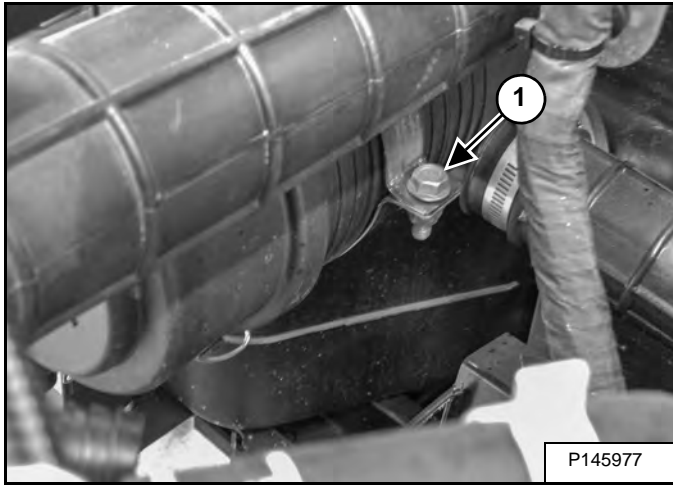

Remove the bolt (Item 1) [Figure 50-40-1].

Figure 50-40-2

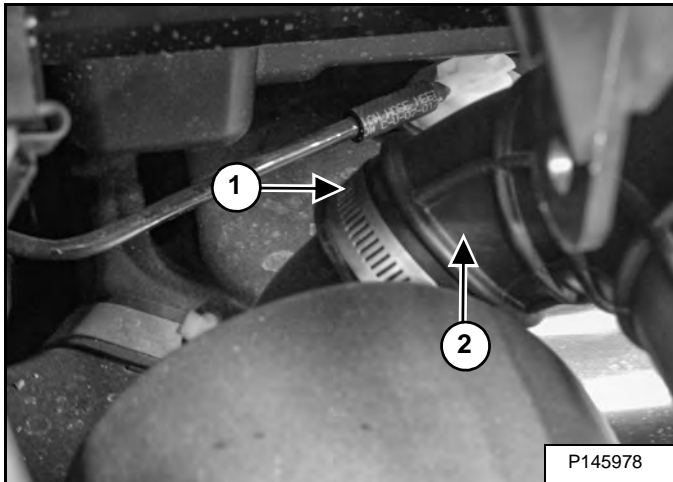

Loosen the clamp (Item 1) and remove the hose (Item 2) [Figure 50-40-2].

Plug the hoses to prevent dirt and debris from entering the engine.

Figure 50-40-3

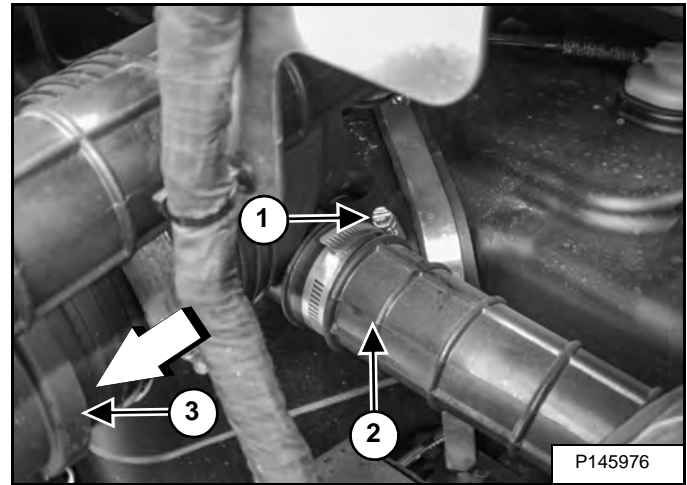

Loosen the clamp (Item 1) and remove the hose (Item 2) [Figure 50-40-3].

Pull the air box (Item 3) [Figure 50-40-3] toward the rear of the vehicle and remove.

ENGINE COOLING SYSTEM (CONT'D)

Radiator Removal And Installation

Remove the front access cover. (See Front Access Cover Removal And Installation on Page 30-30-1.)

WARNING

Never remove radiator cap when engine is warm or hot. The cooling system is under pressure and serious burns may result. Allow the engine and cooling system to cool before servicing.

W-2867-0510

Figure 50-50-4

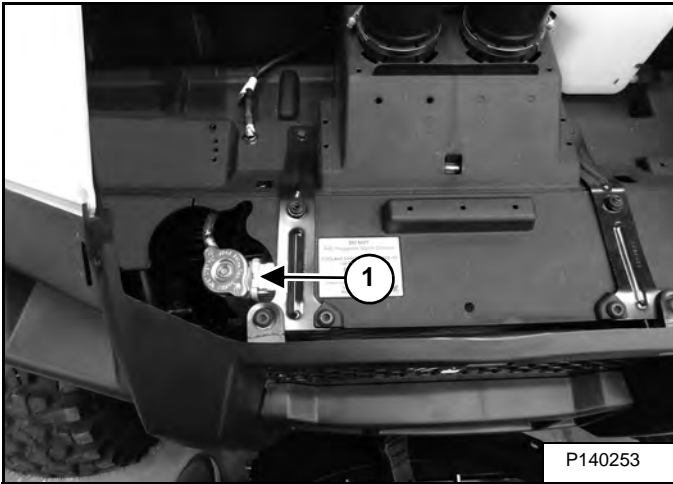

Remove the radiator cap (Item 1) [Figure 50-50-4] to relieve any system pressure.

Place a drain pan under the lower radiator hose.

Figure 50-50-5

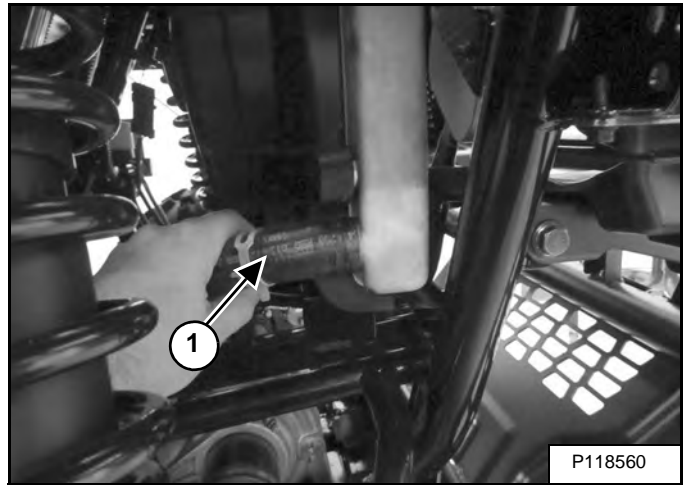

Slide the clamp (Item 1) [Figure 50-50-5] back and remove the lower radiator hose.

Allow the coolant to drain. Properly dispose of the used coolant.

Figure 50-50-6

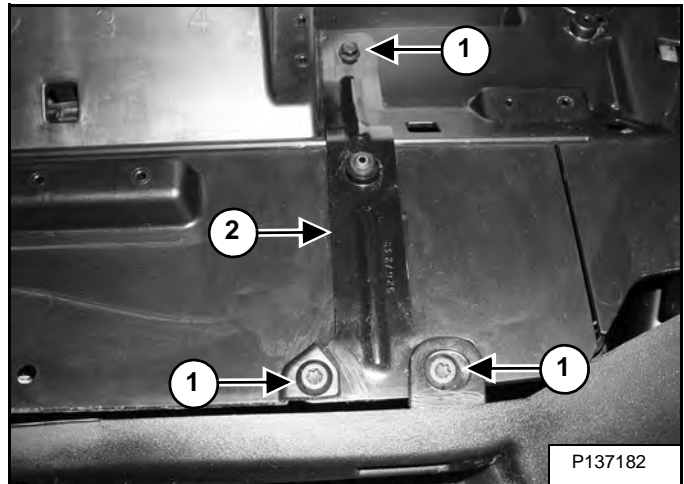

Remove the screws (Item 1) and the bracket (Item 2) [Figure 50-50-6] (both sides).

ENGINE COOLING SYSTEM (CONT'D)

Oil Cooler Removal And Installation (Cont'd)

Figure 50-50-32

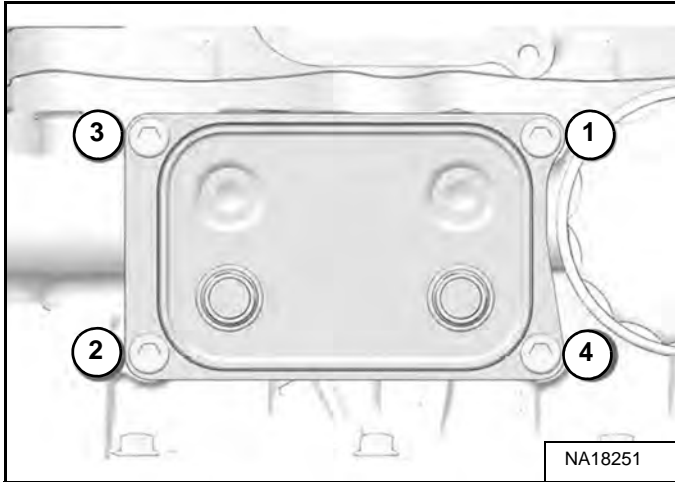

Installation: Tighten the bolts to 10 N•m (7 ft-lb) torque in the sequence shown in [Figure 50-50-32].

Figure 50-50-33

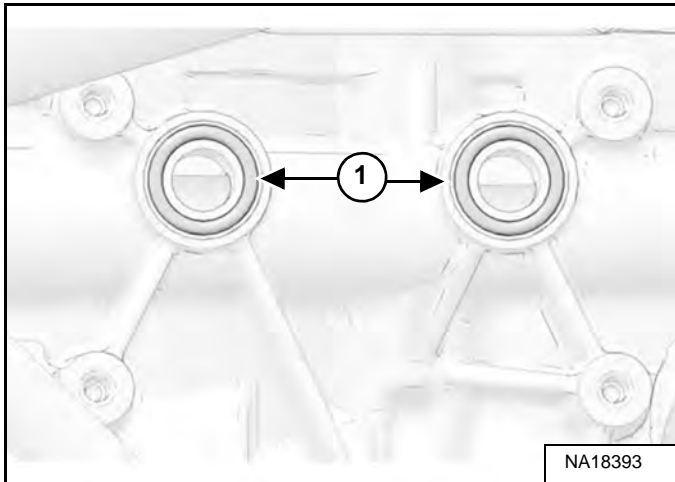

Remove the O-rings (Item 1) [Figure 50-50-33] and discard.

Installation: Install new O-rings.

FUEL SYSTEM (CONT'D)

Fuel Pump Installation

Figure 50-70-10

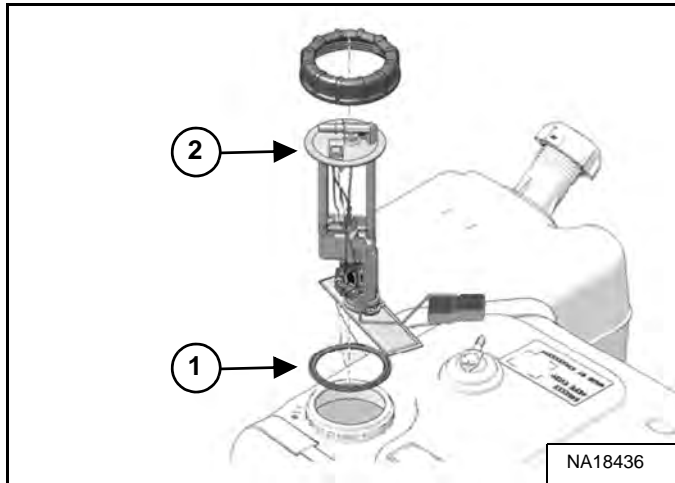

Install the gasket (Item 1) onto the fuel pump (Item 2) [Figure 50-70-10] and place the fuel pump into the fuel tank.

Install the fuel pump into the fuel tank holding float arm to the pump body and tilt the assembly to ensure float arm does not get caught or bent during installation.

Gently push down on the fuel pump flange ensuring flange is centered.

Figure 50-70-11

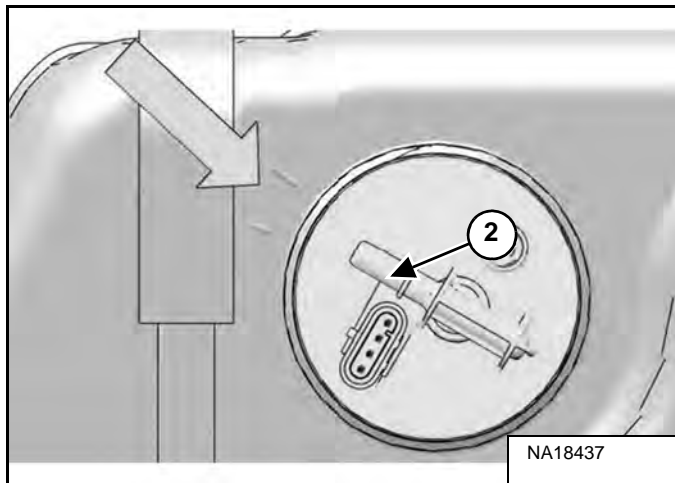

Align the outlet port on the fuel pump between the orientation marks on the fuel tank to ensure that the float arm does not get bent or snagged [Figure 50-70-11].

Figure 50-70-12

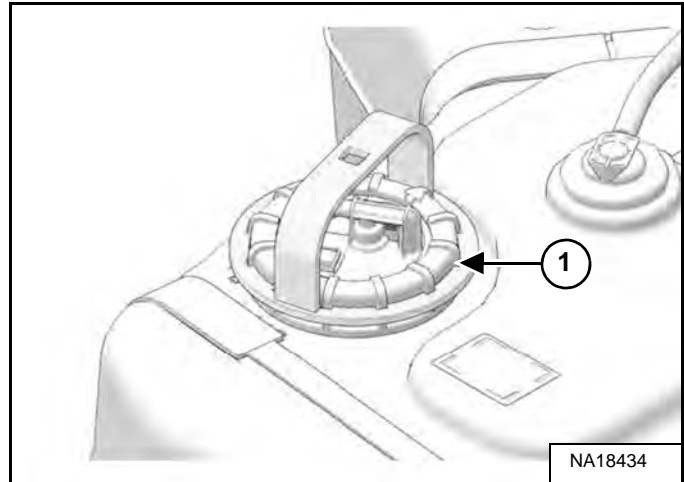

While maintaining downward pressure, thread the new nut (Item 1) [Figure 50-70-12] onto the fuel tank and hand tighten. Use care when starting PFA nut, ensuring threads are properly aligned. Make sure fuel pump does not turn as PFA nut is tightened.

Figure 50-70-13

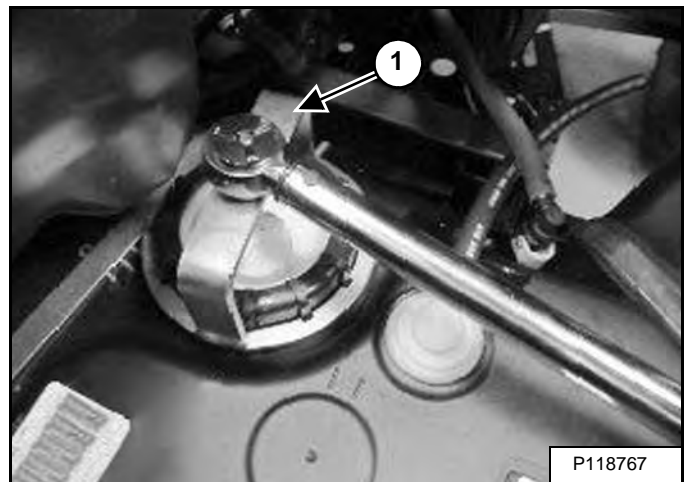

Tighten the PFA nut using the fuel pump service tool (Item 1) [Figure 50-70-13] to 95 N•m (70 ft-lb) torque.

Verify fuel pump is positioned correctly.



Bobcat®

ENGINE DISASSEMBLY / INSPECTION (CONT'D)

Valve Removal (Cont'd)

Figure 50-80-29

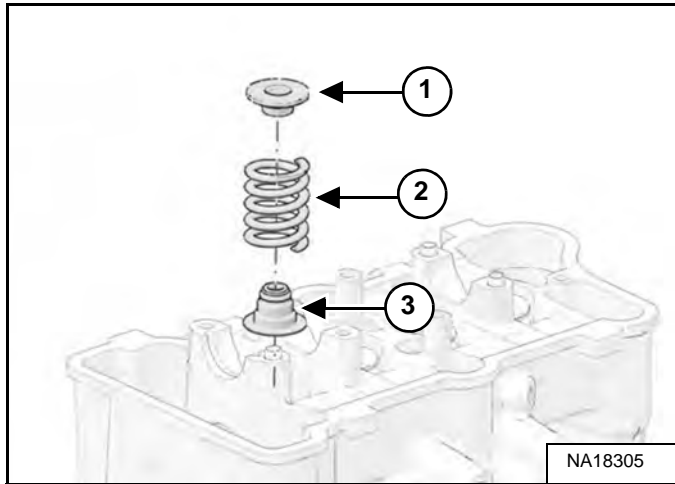

Remove the valve spring cap (Item 1), valve spring (Item 2) and valve stem seal (Item 3) [Figure 50-80-29]. Discard the valve stem seal.

Figure 50-80-30

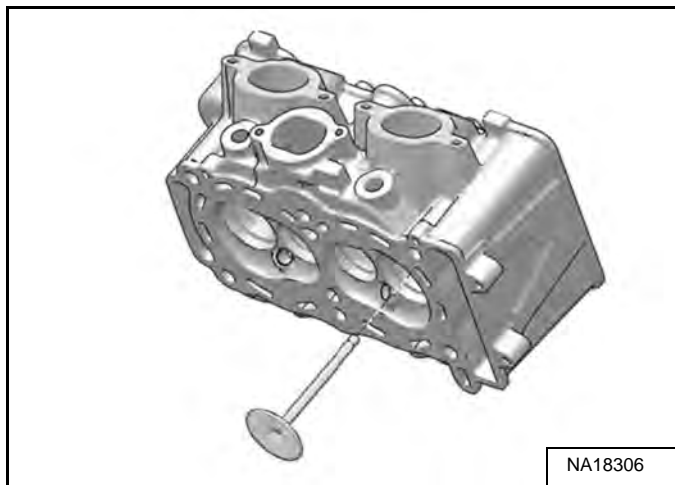

Carefully slide the valve (Item 1) [Figure 50-80-30] out through the bottom of the cylinder head.

Valve Inspection

Remove all carbon from valves with a soft wire wheel or brush.

Figure 50-80-31

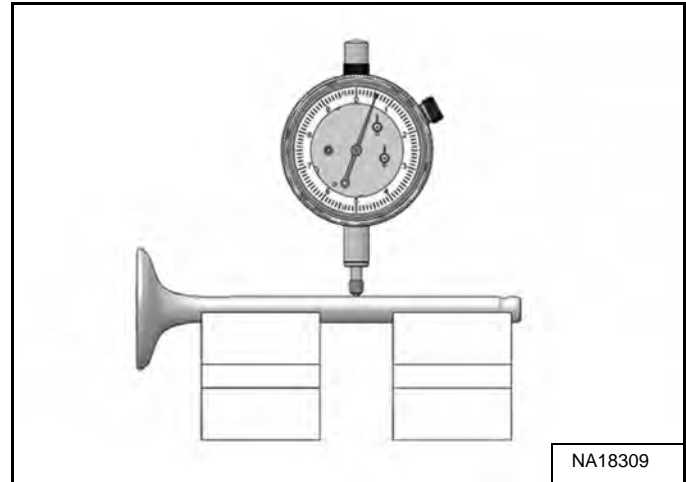

Check valve face for runout, pitting, and burning. To check for bent valve stems, mount valve in a drill or use "V" blocks and a dial indicator [Figure 50-80-31].

Figure 50-80-32

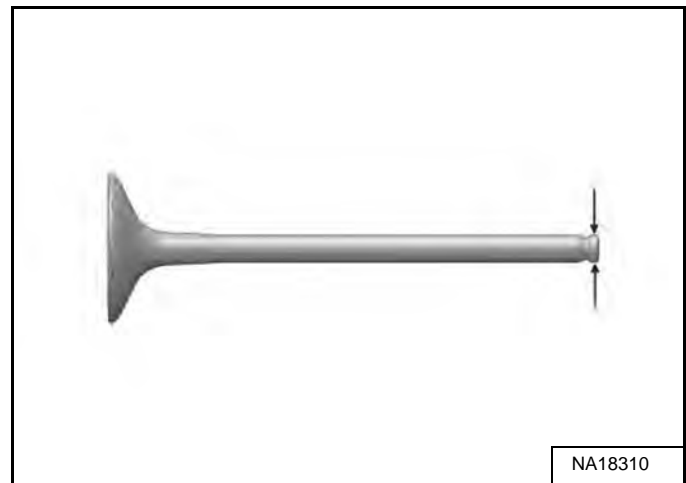

Check the end of the valve stem for flaring, pitting, wear or damage [Figure 50-80-32].

Inspect split keeper groove for wear or flaring in the keeper seat area.

ENGINE DISASSEMBLY / INSPECTION (CONT'D)

Balance Shaft Removal (Cont'd)

Figure 50-80-57

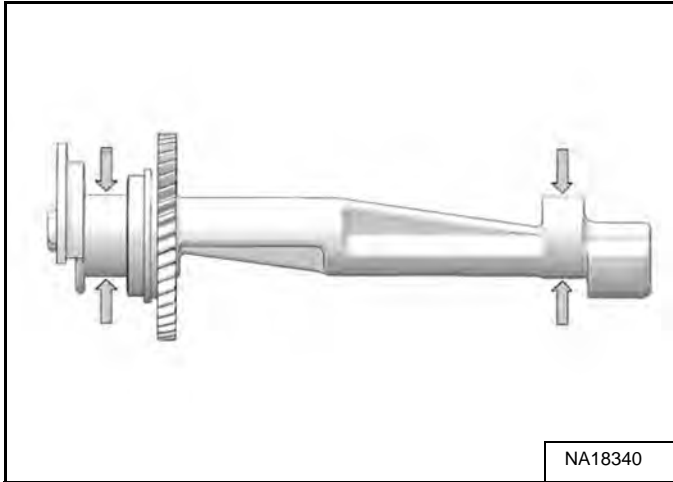

Measure each bearing journal in two locations, 90 degrees apart. Replace balance shaft if either journal is worn below the service limit specification. If worn past the service limit, replace the balance shaft assembly [Figure 50-80-57].

Balance Shaft Diameter	37,946 - 37,962 mm (1.4939 - 1.4946 in)
Service Limit	37,900 mm (1.4921 in)

Crankshaft Removal

Remove the balance shaft. (See Balance Shaft Removal on Page 50-80-19.)

For ease of assembly, mark each connecting rod and end cap.

Figure 50-80-58

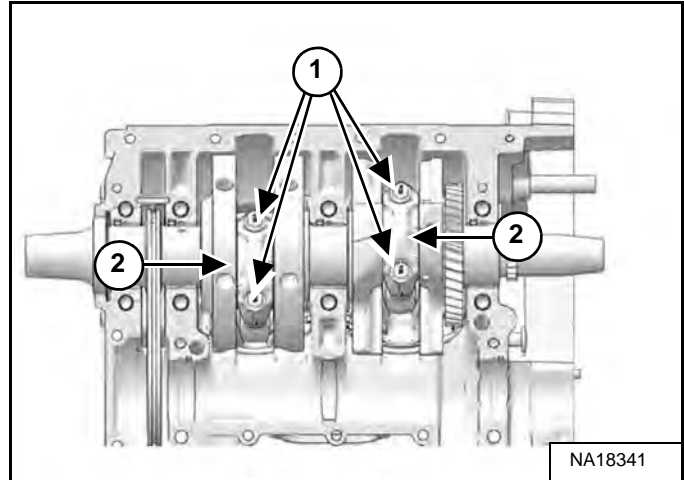

Loosen, remove and discard the four connecting rod bolts (Item 1) [Figure 50-80-58].

Remove the end caps (Item 2) [Figure 50-80-58] from the crankshaft.

Figure 50-80-59

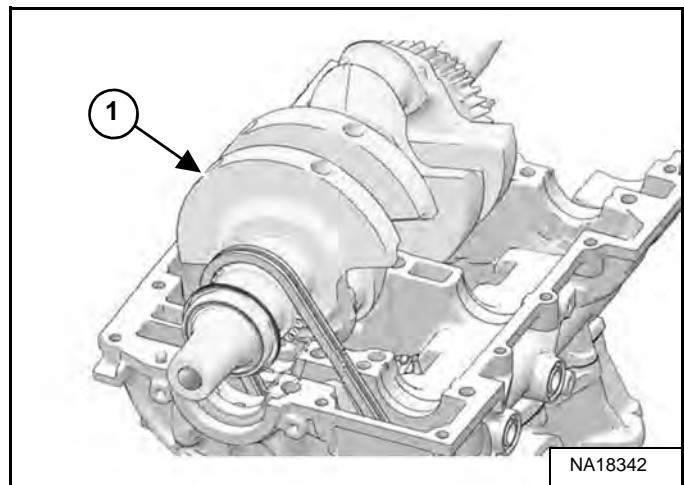

Carefully lift the crankshaft (Item 1) [Figure 50-80-59] out of the crankcase.

ENGINE DISASSEMBLY / INSPECTION (CONT'D)

Connecting Rod Inspection

Figure 50-80-83

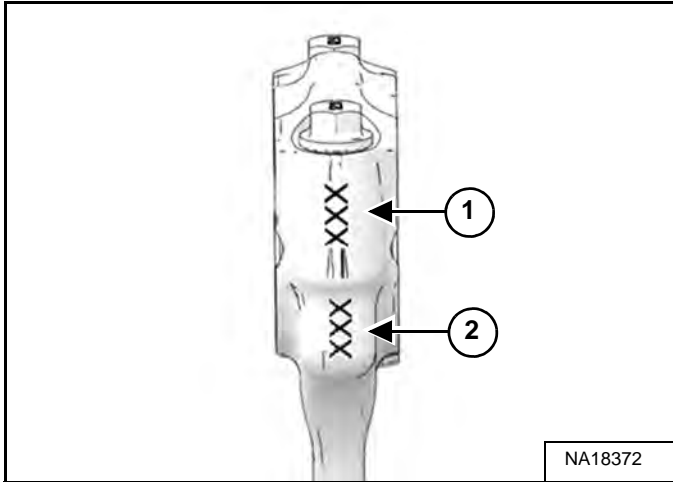

The three digit numbers stamped onto the intake side of the connecting rod are serial numbers used to match the rod cap (Item 1) with the rod stem (Item 2) [Figure 50-80-83].

Figure 50-80-84

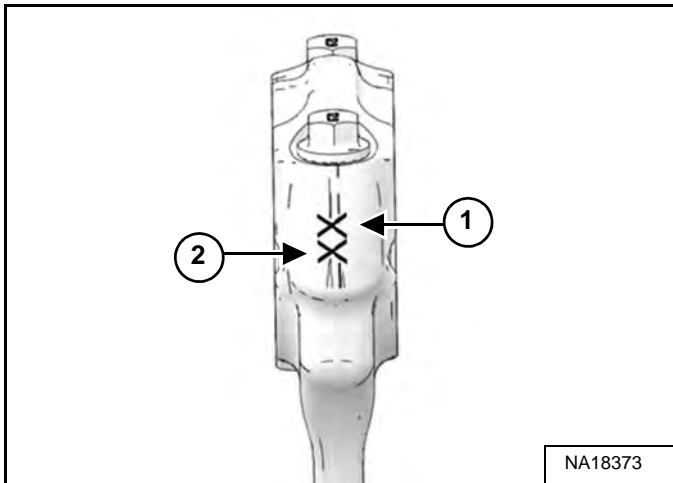

The number (Item 1) and letter (Item 2) stamped onto the exhaust side of the connecting rod represent the bore diameter and weight grading of the connecting rod [Figure 50-80-84].

Inspect the small end and big end of connecting rod (and matching rod cap) for damage, galling of surface or pitting.

Figure 50-80-85

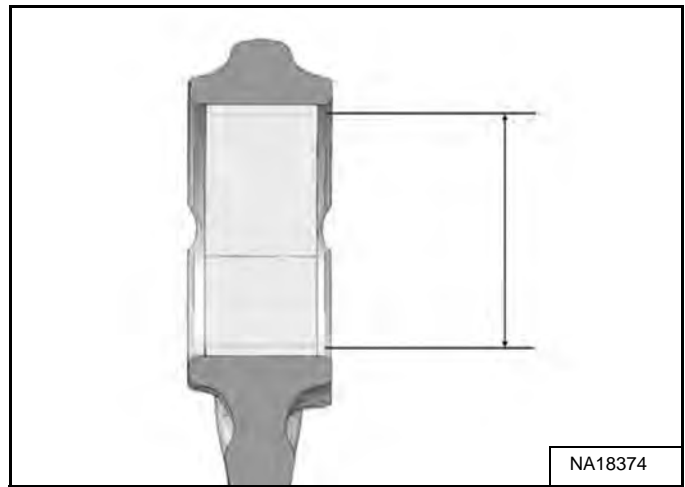

Measure small end I.D. in two directions as shown in [Figure 50-80-85]. Record measurements and compare to specifications. Replace connecting rod if worn past the service limit specification.

Connecting Rod Small End I.D.	20,015 - 20,030 mm (0.7879 - 0.7885 in)
Service Limit	20,06 mm (0.7897 in)

Install matching rod cap on connecting rod (without bearings) and install the bolts.

Tighten bolts snug, then torque to 18 N•m (13 ft-lb).

ENGINE ASSEMBLY (CONT'D)

Crankshaft Installation (Cont'd)

Figure 50-90-15

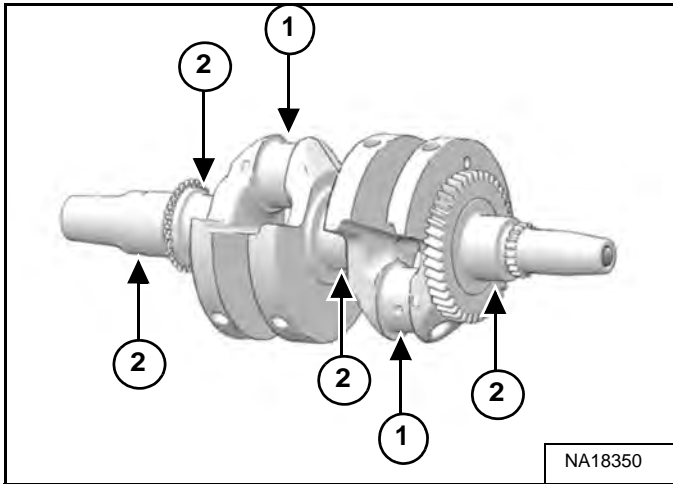

Apply clean engine oil to each rod bearing journal (Item 1) and main bearing journal (Item 2) [Figure 50-90-15] of crankshaft.

Figure 50-90-16

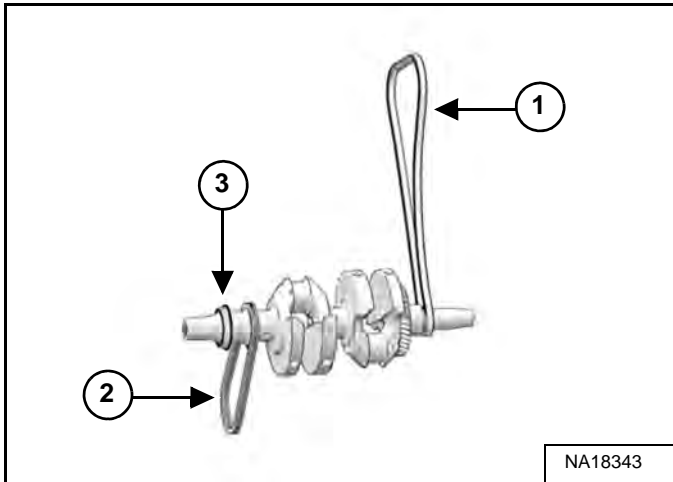

Loop cam chain (Item 1) and oil pump drive chain (Item 2) [Figure 50-90-16] over crankshaft sprockets.

Apply clean engine oil to the new crankshaft oil seal (Item 1) [Figure 50-90-16] and install the seal on the PTO end of the crankshaft.

Figure 50-90-17

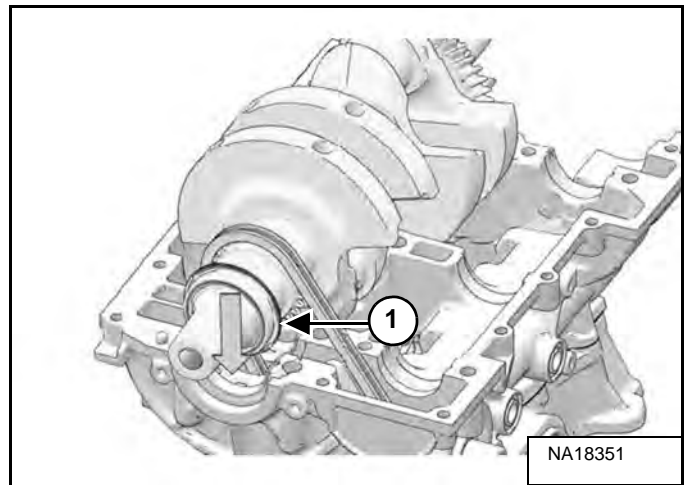

Carefully lower the crankshaft into upper crankcase. Guide connecting rods onto the rod journals of crankshaft as necessary [Figure 50-90-17].

Adjust the PTO crankshaft seal (Item 1) [Figure 50-90-17] so it rests properly in the upper crankcase.

Clean bolt hole threads in connecting rod to remove all oil.

Figure 50-90-18

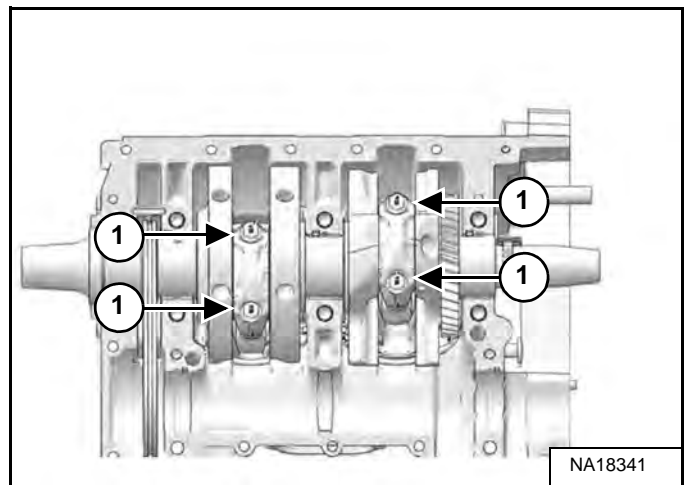

Install new bolts (Item 1) and tighten evenly until snug [Figure 50-90-18].

Torque the connecting rod bolts in the sequence in the table below.

Step 1	Torque to 12 N•m (9 ft-lb)
Step 2	Torque to 30 N•m (22 ft-lb)
Step 3	Tighten an additional 90°

ENGINE ASSEMBLY (CONT'D)

Intake Valve Lash - Tappet Selection Matrix

		Existing Valve Lash Tappet Marking (3 digits on tappet)																																		
		440	442	445	448	450	452	455	458	460	462	465	468	470	472	475	478	480	482	485	488	490	492	495	498	500	502	505	508	510	512	515	518	520	522	525
		Correct Valve Lash Tappet Marking (3 digits on tappet)																																		
Intake Valve Clearance Before Adjusting (mm)	0.000-0.024	428	430	432	435	438	440	442	445	448	450	452	455	458	460	462	465	468	470	472	475	478	480	482	485	488	490	492	495	498	500	502	505	508	510	512
	0.025-0.049	430	432	435	438	440	442	445	448	450	452	455	458	460	462	465	468	470	472	475	478	480	482	485	488	490	492	495	498	500	502	505	508	510	512	515
	0.050-0.074	432	435	438	440	442	445	448	450	452	455	458	460	462	465	468	470	472	475	478	480	482	485	488	490	492	495	498	500	502	505	508	510	512	515	518
	0.075-0.099	435	438	440	442	445	448	450	452	455	458	460	462	465	468	470	472	475	478	480	482	485	488	490	492	495	498	500	502	505	508	510	512	515	518	520
	0.100-0.200 (Standard)																																			
	0.201-0.225	448	450	452	455	458	460	462	465	468	470	472	475	478	480	482	485	488	490	492	495	498	500	502	505	508	510	512	515	518	520	522	525	528	530	532
	0.226-0.250	450	452	455	458	460	462	465	468	470	472	475	478	480	482	485	488	490	492	495	498	500	502	505	508	510	512	515	518	520	522	525	528	530	532	535
	0.251-0.275	452	455	458	460	462	465	468	470	472	475	478	480	482	485	488	490	492	495	498	500	502	505	508	510	512	515	518	520	522	525	528	530	532	535	538
	0.276-0.300	455	458	460	462	465	468	470	472	475	478	480	482	485	488	490	492	495	498	500	502	505	508	510	512	515	518	520	522	525	528	530	532	535	538	540
	0.301-0.325	458	460	462	465	468	470	472	475	478	480	482	485	488	490	492	495	498	500	502	505	508	510	512	515	518	520	522	525	528	530	532	535	538	540	542
	0.326-0.350	460	462	465	468	470	472	475	478	480	482	485	488	490	492	495	498	500	502	505	508	510	512	515	518	520	522	525	528	530	532	535	538	540	542	545
	0.351-0.375	462	465	468	470	472	475	478	480	482	485	488	490	492	495	498	500	502	505	508	510	512	515	518	520	522	525	528	530	532	535	538	540	542	545	
	0.376-0.400	465	468	470	472	475	478	480	482	485	488	490	492	495	498	500	502	505	508	510	512	515	518	520	522	525	528	530	532	535	538	540	542	545		
	0.401-0.425	468	470	472	475	478	480	482	485	488	490	492	495	498	500	502	505	508	510	512	515	518	520	522	525	528	530	532	535	538	540	542	545			
	0.426-0.450	470	472	475	478	480	482	485	488	490	492	495	498	500	502	505	508	510	512	515	518	520	522	525	528	530	532	535	538	540	542	545				
	0.451-0.475	472	475	478	480	482	485	488	490	492	495	498	500	502	505	508	510	512	515	518	520	522	525	528	530	532	535	538	540	542	545					
	0.476-0.500	475	478	480	482	485	488	490	492	495	498	500	502	505	508	510	512	515	518	520	522	525	528	530	532	535	538	540	542	545						
	0.501-0.525	478	480	482	485	488	490	492	495	498	500	502	505	508	510	512	515	518	520	522	525	528	530	532	535	538	540	542	545							
	0.526-0.550	480	482	485	488	490	492	495	498	500	502	505	508	510	512	515	518	520	522	525	528	530	532	535	538	540	542	545								
	0.551-0.575	482	485	488	490	492	495	498	500	502	505	508	510	512	515	518	520	522	525	528	530	532	535	538	540	542	545									
	0.576-0.600	485	488	490	492	495	498	500	502	505	508	510	512	515	518	520	522	525	528	530	532	535	538	540	542	545										
	0.601-0.625	488	490	492	495	498	500	502	505	508	510	512	515	518	520	522	525	528	530	532	535	538	540	542	545											
	0.626-0.650	490	492	495	498	500	502	505	508	510	512	515	518	520	522	525	528	530	532	535	538	540	542	545												
	0.651-0.675	492	495	498	500	502	505	508	510	512	515	518	520	522	525	528	530	532	535	538	540	542	545													
	0.676-0.700	495	498	500	502	505	508	510	512	515	518	520	522	525	528	530	532	535	538	540	542	545														
	0.701-0.725	498	500	502	505	508	510	512	515	518	520	522	525	528	530	532	535	538	540	542	545															
	0.726-0.750	500	502	505	508	510	512	515	518	520	522	525	528	530	532	535	538	540	542	545																
	0.751-0.775	502	505	508	510	512	515	518	520	522	525	528	530	532	535	538	540	542	545																	
0.776-0.800	505	508	510	512	515	518	520	522	525	528	530	532	535	538	540	542	545																			
0.801-0.825	508	510	512	515	518	520	522	525	528	530	532	535	538	540	542	545																				
0.826-0.850	510	512	515	518	520	522	525	528	530	532	535	538	540	542	545																					
0.851-0.875	512	515	518	520	522	525	528	530	532	535	538	540	542	545																						
0.876-0.900	515	518	520	522	525	528	530	532	535	538	540	542	545																							
0.901-0.925	518	520	522	525	528	530	532	535	538	540	542	545																								
0.926-0.950	520	522	525	528	530	532	535	538	540	542	545																									
0.951-0.975	522	525	528	530	532	535	538	540	542	545																										
0.976-1.000	525	528	530	532	535	538	540	542	545																											

NA9463

UTILITY VEHICLE SPECIFICATIONS (CONT'D)

Machine Dimensions

- Dimensions are given for utility vehicle equipped with standard tires.
- Where applicable, specification conform to SAE, ANSI, ISO or OPEI standards and are subject to change without notice.

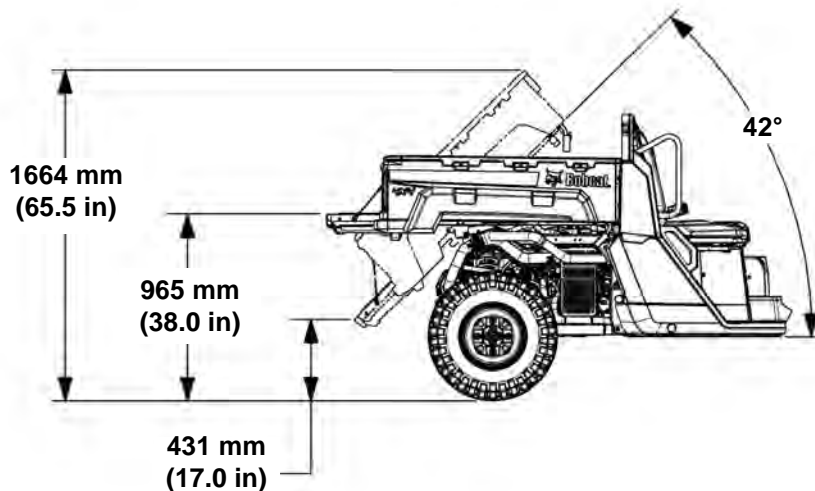
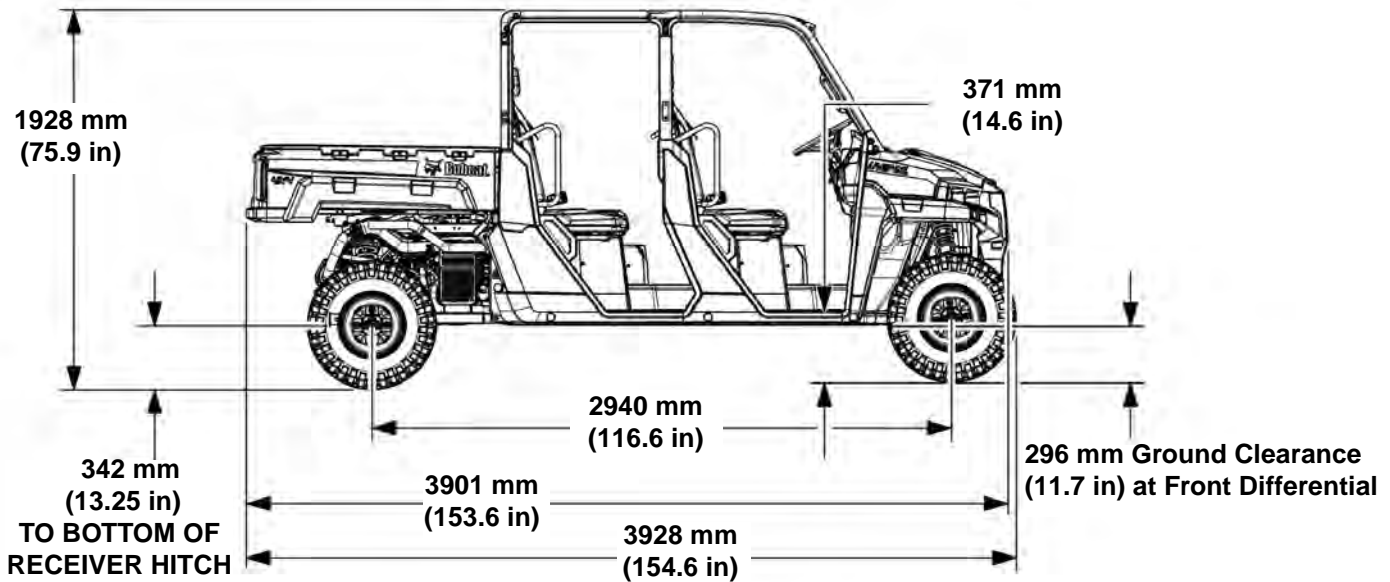
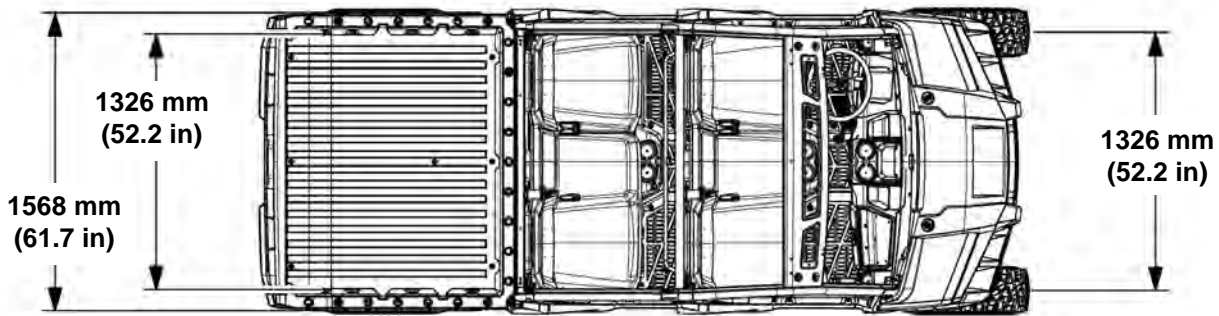

Turning Radius - Turf Mode = 3911 mm (154 in)
 Turning Radius - Two Wheel Drive = 4267 mm (168 in)
 Turning Radius - Four Wheel Drive (4x4) = 4267 mm (168 in)

Box Inside Dimensions:
 1105 x 1372 x 292 mm
 (43.5 x 54 x 11.5 in)

CONVERSIONS (CONT'D)

U.S. To Metric Conversion Chart

	TO CONVERT	INTO	MULTIPLY BY
LINEAR MEASUREMENT	Miles	Kilometers	1.609
	Yards	Meters	0.9144
	Feet	Meters	0.3048
	Feet	Centimeters	30.48
	Inches	Meters	0.0254
	Inches	Centimeters	2.54
	Inches	Millimeters	25.4
AREA	Square Miles	Square Kilometers	2.59
	Square Feet	Square Meters	0.0929
	Square Inches	Square Centimeters	6.452
	Acre	Hectare	0.4047
VOLUME	Cubic Yards	Cubic Meters	0.7646
	Cubic Feet	Cubic Meters	0.02832
	Cubic Inches	Cubic Centimeters	16.39
WEIGHT	Tons (Short)	Metric Tons	0.9078
	Pounds	Kilograms	0.4536
	Ounces (Avdp.)	Grams	28.3495
PRESSURE	Pounds/Sq. In.	Kilopascal	6.895
WORK	Foot-Pounds	Newton-Meter	1.356
LIQUID VOLUME	Quarts	Liters	0.9463
	Gallons	Liters	3.785
LIQUID FLOW	Gallons/Minute	Liters/Minute	3.785
TEMPERATURE	Fahrenheit	Celsius	1. Subtract 32°
			2. Multiply by 5/9

CLICK HERE TO **DOWNLOAD** THE COMPLETE MANUAL

- Thank you very much for reading the preview of the manual.
- You can download the complete manual from: www.heydownloads.com by clicking the link below



- Please note: If there is no response to CLICKING the link, please download this PDF first and then click on it.

CLICK HERE TO **DOWNLOAD** THE COMPLETE MANUAL