



# Bobcat®

## Service Manual



# T870

## T870 Compact Track Loader

S/N A3PG11001 & Above  
S/N A3PH11001 & Above



CLICK HERE TO **DOWNLOAD** THE COMPLETE MANUAL

- Thank you very much for reading the preview of the manual.
- You can download the complete manual from: [www.heydownloads.com](http://www.heydownloads.com) by clicking the link below



- Please note: If there is no response to CLICKING the link, please download this PDF first and then click on it.

CLICK HERE TO **DOWNLOAD** THE COMPLETE MANUAL

## FIRE PREVENTION



### Maintenance

The machine and some attachments have components that are at high temperatures under normal operating conditions. The primary source of high temperatures is the engine and exhaust system. The electrical system, if damaged or incorrectly maintained, can be a source of arcs or sparks.

Flammable debris (leaves, straw, etc.) must be removed regularly. If flammable debris is allowed to accumulate, it can cause a fire hazard. Clean often to avoid this accumulation. Flammable debris in the engine compartment is a potential fire hazard.

The operator's area, engine compartment and engine cooling system must be inspected every day and cleaned if necessary to prevent fire hazards and overheating.

All fuels, most lubricants and some coolants mixtures are flammable. Flammable fluids that are leaking or spilled onto hot surfaces or onto electrical components can cause a fire.

### Operation

Do not use the machine where exhaust, arcs, sparks or hot components can contact flammable material, explosive dust or gases.

### Electrical



Check all electrical wiring and connections for damage. Keep the battery terminals clean and tight. Repair or replace any damaged part or wires that are loose or frayed.

Battery gas can explode and cause serious injury. Use the procedure in the Operation & Maintenance Manual for connecting the battery and for jump starting. Do not jump start or charge a frozen or damaged battery. Keep any open flames or sparks away from batteries. Do not smoke in battery charging area.

## Hydraulic System

Check hydraulic tubes, hoses and fittings for damage and leakage. Never use open flame or bare skin to check for leaks. Hydraulic tubes and hoses must be properly routed and have adequate support and secure clamps. Tighten or replace any parts that show leakage.

Always clean fluid spills. Do not use gasoline or diesel fuel for cleaning parts. Use commercial nonflammable solvents.

### Fueling



Stop the engine and let it cool before adding fuel. No smoking! Do not refuel a machine near open flames or sparks. Fill the fuel tank outdoors.

Ultra Low Sulfur Diesel (ULSD) poses a greater static ignition hazard than earlier diesel formulations with higher Sulfur content. Avoid death or serious injury from fire or explosion. Consult with your fuel or fuel system supplier to ensure the delivery system is in compliance with fueling standards for proper grounding and bonding practices.

### Starting

Do not use ether or starting fluids on any engine that has glow plugs or air intake heater. These starting aids can cause explosion and injure you or bystanders.

Use the procedure in the Operation & Maintenance Manual for connecting the battery and for jump starting.

### Spark Arrester Exhaust System

The spark arrester exhaust system is designed to control the emission of hot particles from the engine and exhaust system, but the muffler and the exhaust gases are still hot.

Check the spark arrester exhaust system regularly to make sure it is maintained and working properly. Use the procedure in the Operation & Maintenance Manual for cleaning the spark arrester muffler (if equipped).

## LIFT ARM SUPPORT DEVICE

### Installing

# ! WARNING

Never work on a machine with the lift arms up unless the lift arms are secured by an approved lift arm support device. Failure to use an approved lift arm support device can allow the lift arms or attachment to fall and cause injury or death.

Service lift arm support device if damaged or if parts are missing. Using a damaged lift arm support or with missing parts can cause lift arms to drop causing injury or death.

W-2572-0407

# ! DANGER

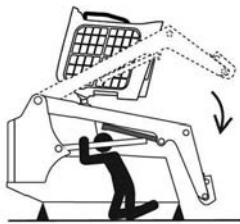

P-90328

### AVOID DEATH

- Disconnecting or loosening any hydraulic tubeline, hose, fitting, component or a part failure can cause lift arms to drop.
- Keep out of this area when lift arms are raised unless supported by an approved lift arm support. Replace if damaged.

D-1009-0409

Remove attachment from the loader. (See Removal And Installation on Page 50-40-1.) **OR** (See Removal And Installation on Page 50-41-1.)

Figure 10-20-1

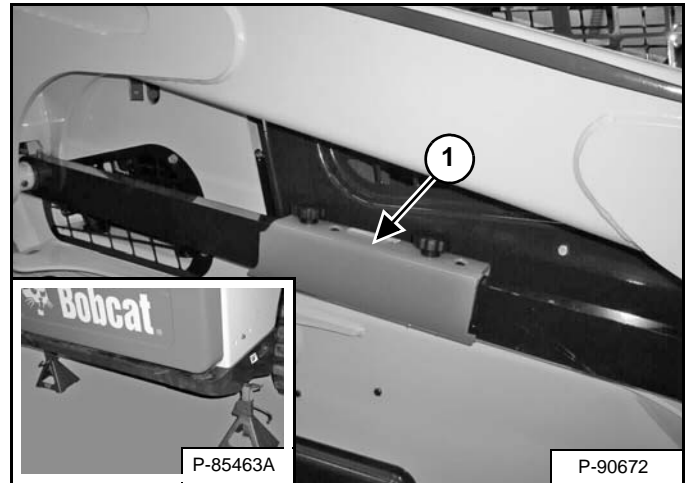

Put jackstands under the rear corners of the loader frame (Inset) [Figure 10-20-1].

Remove the lift arm support device (Item 1) [Figure 10-20-1] from the storage position.

The operator must stay in the operator seat with the seat belt fastened and the seat bar lowered until the lift arm support device is installed.

Start the engine and raise the lift arms all the way up.

Figure 10-20-2



Have a second person install the lift arm support device over the rod of one of the lift cylinders [Figure 10-20-2].

The lift arm support device must be tight against the cylinder rod.

## REMOTE START TOOL KIT - MEL1563

### Remote Start Tool - MEL1563

Tools that will be needed to complete the following steps are:

MEL1563 - Remote Start Tool Kit

MEL1566 - Service Tool Harness Communicator (Computer Interface)

**Figure 10-60-1**

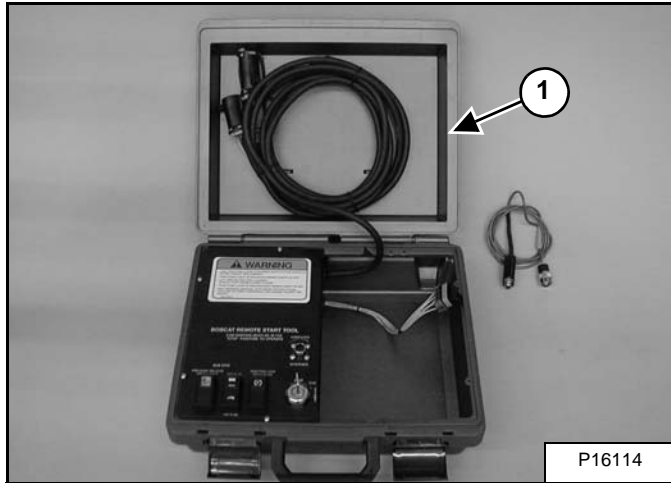

The Remote Start Tool (Item 1) [Figure 10-60-1] is required when the service technician is checking the hydraulic / hydrostatic system, adjusting the steering linkage, and electrical diagnostics.

**Figure 10-60-2**

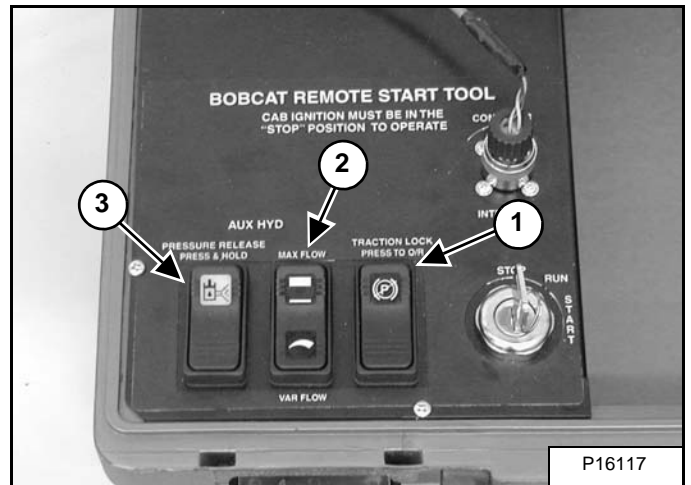

The traction lock switch (Item 1) [Figure 10-60-2] is used to turn traction lock ON or OFF. Push the switch to the override position. The switch will illuminate to indicate traction lock OVERRIDE, in this position the wheels are able to turn.

The maximum flow / variable flow switch (Item 2) [Figure 10-60-2] is used to activate the auxiliary hydraulics. Pressing the switch will activate variable flow. The switch will illuminate to indicate the flow rate is active. Pressing the switch again will turn the flow OFF. The switch is used when checking pressures and flow rate.

**NOTE: With the engine running; pushing and holding the pressure release switch (Item 3) [Figure 10-60-2] will cause the engine to stop.**

**REMOTE START TOOL (SERVICE TOOL) KIT - 7217666 (CONT'D)**

**Remote Start Procedure (Cont'd)**

**Figure 10-61-13**

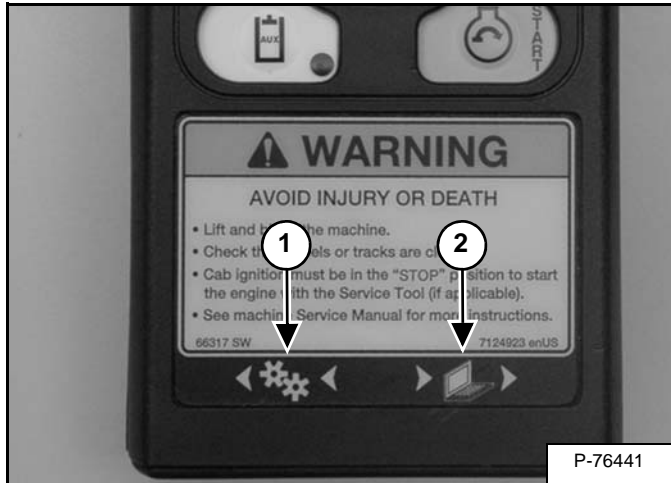

The gear icon with the left facing arrows (Item 1) [Figure 10-61-13] will illuminate and blink when the RUN key is pressed and the loader is communicating with the service tool.

The computer icon with the right facing arrows (Item 2) [Figure 10-61-13] will illuminate and blink when the Remote Start Tool (Service Tool) is transmitting data to and from the computer.

**NOTE:** To relieve the pressure at the rear or secondary front auxiliary, (if equipped) press the RUN button on the Remote Start Tool. Then press the auxiliary (AUX) hydraulics button on the Remote Start Tool and move the AUXILIARY Hydraulic Switch to the right and left several times.

**Figure 10-61-14**

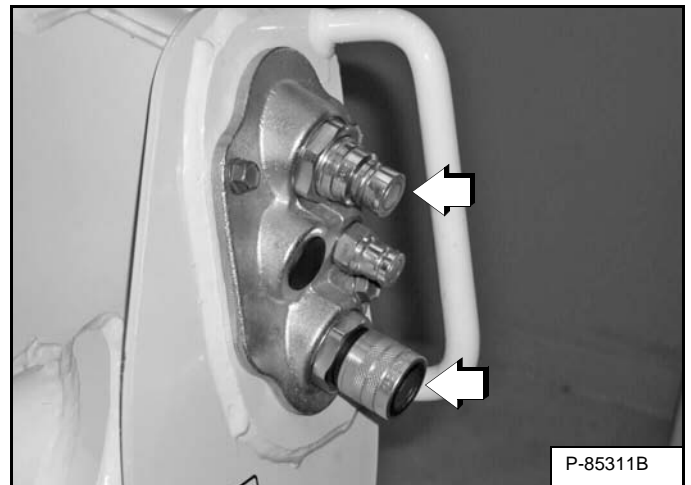

Push the couplers on the front auxiliary block toward the block and hold for five seconds to release the front auxiliary pressure [Figure 10-61-14].

## FUEL SYSTEM

### Fuel Specifications

**NOTE: Contact your local fuel supplier to receive recommendations for your region.**

At a minimum, low sulfur diesel fuel must be used in this machine. Low sulfur is defined as 500 mg/kg (500 ppm) sulfur maximum.

*U.S. Standard (ASTM D975)*

Use only clean, high quality diesel fuel, Grade Number 2-D or Grade Number 1-D.

Ultra low sulfur diesel fuel may also be used in this machine. Ultra low sulfur is defined as 15 mg/kg (15 ppm) sulfur maximum.

The following is one suggested blending guideline that should prevent fuel gelling during cold temperatures:

TEMPERATURE	GRADE 2-D	GRADE 1-D
Above -9°C (+15°F)	100%	0%
Down to -21°C (-5°F)	50%	50%
Below -21°C (-5°F)	0%	100%

**NOTE: Biodiesel blend fuel may also be used in this machine. Biodiesel blend fuel must contain no more than five percent biodiesel mixed with ultra low sulfur petroleum based diesel. This biodiesel blend fuel is commonly marketed as B5 blended diesel fuel. B5 blended diesel fuel must meet ASTM specifications.**

*E.U. Standard (EN590)*

Use only clean, high quality diesel fuel that meets the specifications listed below:

- Low sulfur diesel fuel defined as 500 mg/kg (500 ppm) sulfur maximum
- Diesel fuel with cetane number of 51.0 and above.

Clean, high quality diesel fuel that meets the EN590 specification may also be used.

**NOTE: Biodiesel blend fuel may also be used in this machine. Biodiesel blend fuel must contain no more than seven percent biodiesel mixed with ultra low sulfur petroleum based diesel. This biodiesel blend fuel is commonly marketed as B7 blended diesel fuel. B7 blended diesel fuel must meet EN590 specifications.**

## Biodiesel Blend Fuel

Biodiesel blend fuel has unique qualities that should be considered before using in this machine:

- Cold weather conditions can lead to plugged fuel system components and hard starting.
- Biodiesel blend fuel is an excellent medium for microbial growth and contamination which can cause corrosion and plugging of fuel system components.
- Use of biodiesel blend fuel may result in premature failure of fuel system components, such as plugged fuel filters and deteriorated fuel lines.
- Shorter maintenance intervals may be required, such as cleaning the fuel system and replacing fuel filters and fuel lines.
- Using biodiesel blended fuels containing more than five percent biodiesel can affect engine life and cause deterioration of hoses, tubelines, injectors, injector pump and seals.

Apply the following guidelines if biodiesel blend fuel is used:

- Ensure the fuel tank is as full as possible at all times to prevent moisture from collecting in the fuel tank.
- Ensure that the fuel tank cap is securely tightened.
- Biodiesel blend fuel can damage painted surfaces, remove all spilled fuel from painted surfaces immediately.
- Drain all water from the fuel filter daily before operating the machine.
- Do not exceed engine oil change interval. Extended oil change intervals can cause engine damage.
- Before vehicle storage; drain the fuel tank, refill with 100% petroleum diesel fuel, add fuel stabilizer and run the engine for at least 30 minutes.

**NOTE: Biodiesel blend fuel does not have long term stability and should not be stored for more than three months.**

## HYDRAULIC / HYDROSTATIC SYSTEM (CONT'D)

### Removing And Replacing Hydraulic Charge Filter

The hydraulic charge filter is located under the operator cab. For the correct service interval (See SERVICE SCHEDULE on Page 10-70-1.)

Stop the engine and raise the operator cab. (See Raising on Page 10-30-2.)

Figure 10-120-15

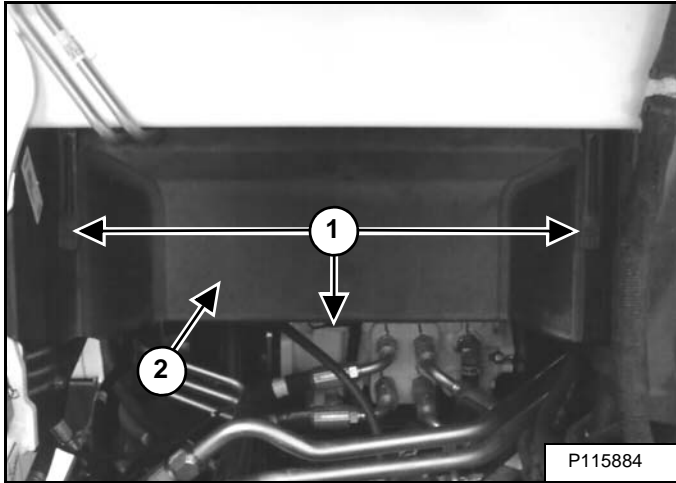

Unhook the three rubber straps (Item 1) and remove the lower fan duct (Item 2) [Figure 10-120-15]. (Earlier models used four rubber straps.)

**NOTE:** Identification of the hydraulic charge filter used on your machine is necessary to perform the correct replacement procedure.

Figure 10-120-16

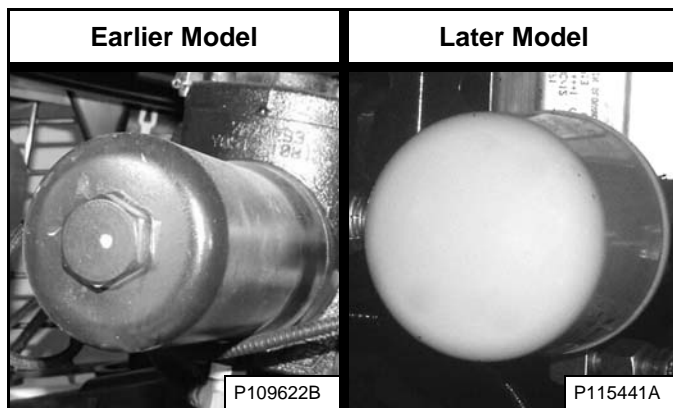

Earlier models use a separate filter housing and filter element. Later models use a spin-on filter [Figure 10-120-16].

### Earlier Models

Figure 10-120-17

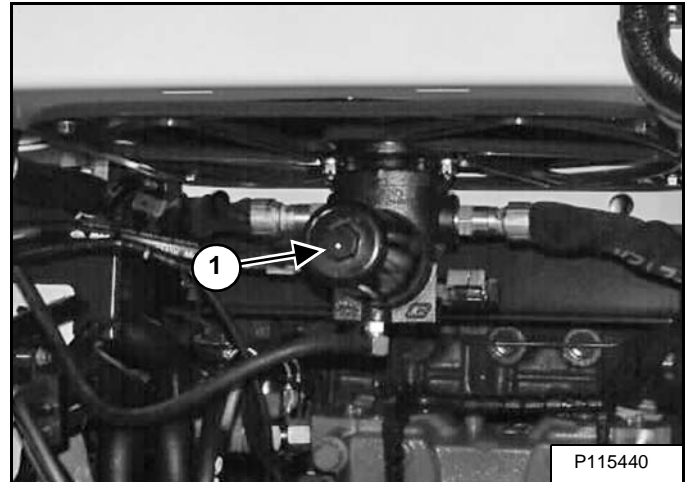

Put a suitable container below the filter housing and remove the filter housing (Item 1) [Figure 10-120-17] using a socket wrench.

Figure 10-120-18

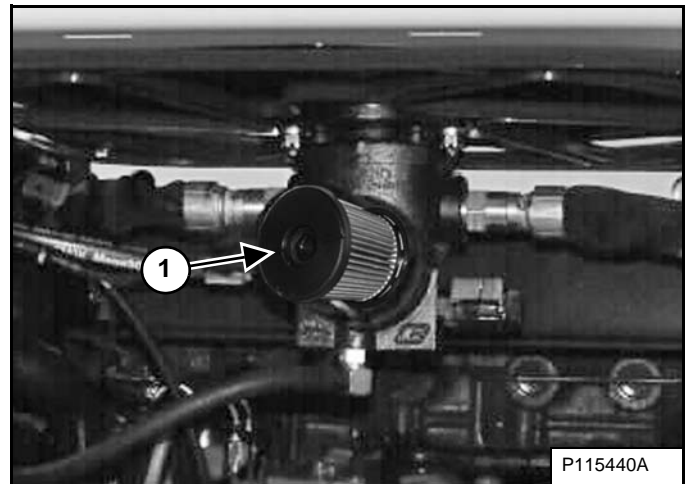

Remove and discard the filter element (Item 1) [Figure 10-120-18].

Clean the surface of the filter housing and the filter base where they contact the filter element seal.

Put clean oil on the seal of the new filter element. Install the element on the filter base.

Install and tighten the filter housing to 65 - 70 N•m (48 - 52 ft-lb) torque.

## SPARK ARRESTER MUFFLER

### Cleaning Procedure

See the SERVICE SCHEDULE for service interval for cleaning the spark arrester muffler. (See SERVICE SCHEDULE on Page 10-70-1.)

Do not operate the loader with a defective exhaust system.

## IMPORTANT

This machine is factory equipped with a U.S.D.A. Forestry Service Approved spark arrester exhaust system that must be maintained for proper function.

- **WITH MUFFLER**  
The muffler spark chamber must be emptied every 100 hours of operation to keep it in working condition.
- **WITH SELECTIVE CATALYST REDUCTION (SCR) AND / OR DIESEL OXIDATION CATALYST (DOC)**  
Do not remove or modify the DOC or SCR.

The SCR must be maintained according to the instructions in the Operation & Maintenance Manual for proper function.

- **WITH DIESEL PARTICULATE FILTER (DPF)**  
The DPF must be maintained according to the instructions in the Operation & Maintenance Manual for proper function.

(If this machine is operated on flammable forest, brush or grass cover land, the engine must be equipped with a spark arrester and maintained in working order. Failure to do so will be in violation of California state law section 4442 PRC. Refer to local laws and regulations for spark arrester requirements.)

I-2350-1114

Stop the engine and open the rear door. (See REAR DOOR (TAILGATE) on Page 50-70-1.)

## WARNING

Never use machine in atmosphere with explosive dust or gases or where exhaust can contact flammable material. Failure to obey warnings can cause injury or death.

W-2068-1285

Figure 10-150-1

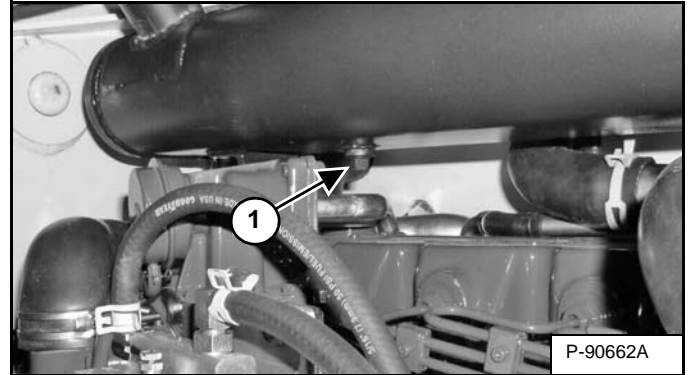

Remove the plug (Item 1) [Figure 10-150-1] from the bottom of the muffler.

## SEAT BELT

### Inspection And Maintenance

# WARNING

Failure to properly inspect and maintain the seat belt can cause lack of operator restraint resulting in serious injury or death.

W-2466-0703

Check the seat belt daily for correct function.

Inspect the seat belt system thoroughly at least once each year or more often if the machine is exposed to severe environmental conditions or applications.

Any seat belt system that shows cuts, fraying, extreme or unusual wear, significant discolorations due to ultraviolet UV exposure, dusty / dirty conditions, abrasion to the seat belt webbing, or damage to the buckle, latch plate, retractor (if equipped), hardware or any other obvious problem should be replaced immediately.

The items below are referenced in **[Figure 10-200-1]**.

1. Check the webbing. If the system is equipped with a retractor, pull the webbing completely out and inspect the full length of the webbing. Look for cuts, wear, fraying, dirt and stiffness.
2. Check the buckle and latch for correct operation. Make sure latch plate is not excessively worn, deformed or buckle is not damaged or casing broken.
3. Check the retractor web storage device (if equipped) by extending webbing to determine if it looks correct and that it spools out and retracts webbing correctly.
4. Check webbing in areas exposed to ultraviolet (UV) rays from the sun or extreme dust or dirt. If the original color of the webbing in these areas is extremely faded and / or the webbing is packed with dirt, the webbing strength may have deteriorated.

Figure 10-200-1

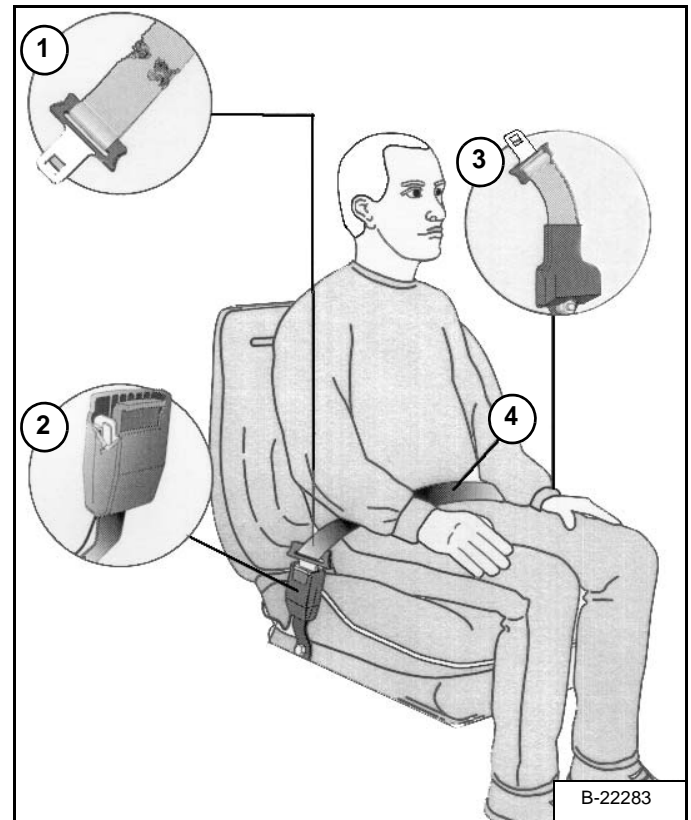

# HYDRAULIC/HYDROSTATIC SCHEMATIC WITH NO OPTIONS

## T870 (S/N A3PG12800 AND ABOVE) (S/N A3PH12326 AND ABOVE)

(PRINTED AUGUST 2012)  
V-1517legend



### LEGEND

- |  |  |  |
|--|--|--|
| <p>① RESERVOIR:<br/>Capacity at sight gauge . . . 9,75 L (10.3 qt)<br/>System Capacity . . . . . 36 L (9.5 U.S. gal)</p> <p>② SIGHT GAUGE</p> <p>③ DIFFERENTIAL PRESSURE SWITCH:<br/>103 kPa (1,03 bar) (15 psi)<br/>Normally Closed</p> <p>④ FILTER - HYDRAULIC (CANISTER)</p> <p>⑤ SPRING LOADED FILTER BY-PASS VALVE: 1,72 kPa (1,7 bar) (25 psi)</p> <p>⑥ DIAGNOSTIC COUPLER</p> <p>⑦ RELIEF VALVE - MAIN:<br/>27234 – 27924 kPa (272 - 279 bar)<br/>(3950 - 4050 psi) at Diagnostic Coupler ⑥</p> <p>⑦A RELIEF VALVE - AUXILIARY:<br/>23787 – 24476 kPa (238 - 245 bar)<br/>(3450 - 3550 psi) at Front Quick Couplers</p> <p>⑧ RELIEF/ANTICAVITATION VALVE - PORT: 31026 kPa (310 bar) (4500 psi)</p> <p>⑨ RELIEF/ANTICAVITATION VALVE - PORT 27579 kPa (276 bar) (4000 psi)<br/>(AUXILIARY RELIEF IS OPTIONAL)</p> <p>⑩ SOLENOID ACTIVATED DIRECTIONAL CONTROL VALVE - AUXILIARY</p> <p>⑪ LOAD CHECK VALVE</p> <p>⑫ ANTICAVITATION VALVE</p> <p>⑬ PILOTED ACTIVATED DIRECTIONAL CONTROL VALVE - TILT CONTROL</p> <p>⑭ PILOTED ACTIVATED DIRECTIONAL CONTROL VALVE - LIFT CONTROL</p> <p>⑮ SOLENOID ACTIVATED DIRECTIONAL CONTROL VALVE - BICS CONTROL</p> <p>⑯ FILTER - BICS CONTROL VALVE (SCREEN)</p> <p>⑰ CHECK VALVE - With 100 kPa (1,0 bar) (14.5 psi) Spring</p> <p>⑱ RESTRICTION . . . . . 2,0 mm (0.079 in)</p> | <p>⑲ PULL BUTTON ACTIVATED DIRECTIONAL CONTROL VALVE - LIFT ARM BY-PASS</p> <p>⑳ LIFT CYLINDER SPOOL - MADE TO RESTRICT FLOW DURING BOOM DOWN BUT NOT DURING BOOM UP</p> <p>㉑ ANTICAVITATION VALVE</p> <p>㉒ PROPORTIONAL RELIEF VALVE – (Fan Speed Regulator): 10797 – 12300 kPa (108 - 123 bar) (1566 - 1784 psi)</p> <p>㉓ SPRING LOADED FILTER BY-PASS VALVE: 517 – 572 kPa (5,2 - 5,7 bar) (75 - 83 psi)</p> <p>㉔ FIXED CAPACITY DISPLACEMENT HYDRAULIC MOTOR</p> <p>㉕ FILTER - HYDRAULIC (CANISTER)</p> <p>㉖ SENSOR – CHARGE PRESSURE – Fan Filter</p> <p>㉗ FRONT AUXILIARY MANUAL PRESSURE BLEED-OFF VALVE</p> <p>㉘ SENSOR – HYD. TEMPERATURE</p> <p>㉙ RESTRICTION - 1,7 mm (0.067 in)</p> <p>㉚ CHECK VALVE - With 1379 kPa (13,8 bar) (200 psi) Spring</p> <p>㉛ DRIVE MOTOR SHUTTLE VALVE</p> <p>㉜ Not Used For This Model</p> <p>㉝ Not Used For This Model</p> <p>㉞ FIXED CAPACITY DISPLACEMENT BIDIRECTIONAL HYDROSTATIC MOTOR</p> <p>㉟ HYDRAULIC BRAKE – SPRING APPLIED – PRESSURE RELEASE (SAPR)</p> | <p>㊳ VARIABLE CAPACITY DISPLACEMENT BIDIRECTIONAL HYDROSTATIC PUMP</p> <p>㊴ CHECK VALVE – COLD WEATHER BY-PASS<br/>With 345 kPa (3,45 bar) (50 psi) Spring</p> <p>㊵ SERVO PISTON – Swash Plate</p> <p>㊶ RELIEF/REPLENISHING VALVE - HIGH PRESSURE: 39645 kPa (396 bar) (5750 psi)</p> <p>㊷ RELIEF VALVE - CHARGE INLET: 2965 – 3654 kPa (29,6 – 36,5 bar) (430 – 530 psi) at High Engine Idle With 60 degrees C. (140 degrees F.) Fluid</p> <p>㊸ SOLENOID ACTIVATED DIRECTIONAL CONTROL VALVE – FORWARD/REVERSE</p> <p>㊹ FILTER (Screen)</p> <p>㊺ Not Used For This Model</p> <p>㊻ Not Used For This Model</p> <p>㊼ Not Used For This Model</p> <p>㊽ SOLENOID ACTIVATED DIRECECTIONAL CONTROL VALVE – BRAKE</p> <p>㊾ FILTER - BRAKE</p> <p>㊿ HYDRAULIC PUMP . . . . . Gear Type<br/>87,1 L/min (23.0 U.S. gpm) at High Engine Idle</p> <p>① CHARGE PUMP -<br/>51,1 L/min (13.5 U.S. gpm) at High Engine Idle</p> |
|--|--|--|

**NOTE:** Unless otherwise specified springs have NO significant pressure value.

# HYDRAULIC SYSTEM INFORMATION (CONT'D)

## Glossary Of Hydraulic / Hydrostatic Symbols (Cont'd)

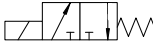
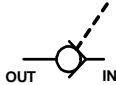
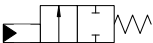
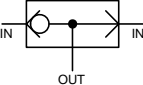
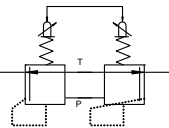
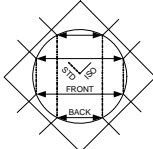
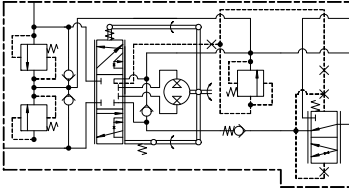
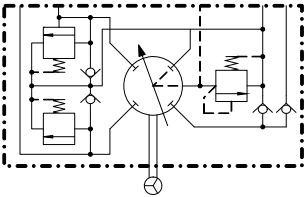
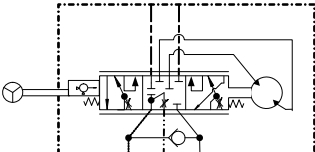
SYMBOL	DESCRIPTION	SYMBOL	DESCRIPTION
	<p><b>NON-RETURN VALVE (Check Valve)</b>                      - Used as Replenishing Valve, Lock Check Valve or Anticavitation Valve - Opens if the Inlet pressure is higher than the Outlet pressure. Often contains internal spring which has NO significant pressure value.</p>		<p><b>TWO PORTS and CLOSED FLOW PATHS</b></p>
	<p><b>SPRING LOADED VALVE (bypass Valve)</b> - Opens if the Inlet pressure is greater than the Outlet pressure plus the spring pressure.</p>		<p><b>SOLENOID ACTIVATED DIRECTIONAL CONTROL VALVE (Two Position)</b> - controlled by an electric solenoid (with return spring).</p>
	<p><b>PILOT CONTROLLED NON-RETURN VALVE</b>- It is possible to open the valve by pilot pressure.</p>		<p><b>PILOT ACTIVATED DIRECTIONAL CONTROL VALVE (Two Position)</b> - controlled by pressure (with return spring).</p>
	<p><b>SHUTTLE VALVE</b> - The Inlet port connected to the higher pressure is automatically connected to the Outlet port while the other Inlet port is closed.</p>		<p><b>MANUALLY ACTIVATED DIRECTION CONTROL VALVE (Variable Position)</b> Joystick Controlled, variable pressure to shift the pilot activated directional control valve spool.</p>
			<p><b>MANUALLY ACTIVATED FLOW CONTROL VALVE (Two Position)</b> allows for changing pilot flow to control switching joystick functions for STD / ISO Control (Excavators Only).</p>
			<p><b>STEERING CONTROL VALVE (Variable Position)</b> - Used for controlling the hydraulic flow for the steering cylinders in relationship to the amount the steering wheel is rotated.</p>
			
			

## CYLINDER (LIFT) (CONT'D)

### Disassembly (Cont'd)

Figure 20-20-17

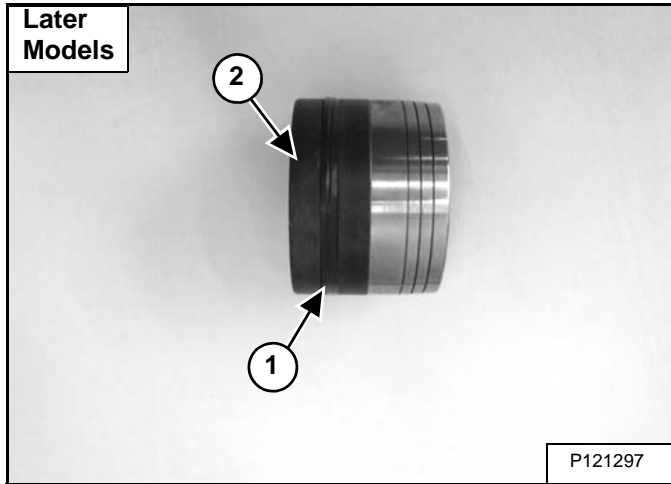

Remove the seal (Item 1) [Figure 20-20-17] from the piston.

**NOTE:** If the fiber surface (Item 2) [Figure 20-20-17] on the piston, becomes damaged, the complete piston must be replaced.

**NOTE:** The seal is a two piece seal.

Figure 20-20-18

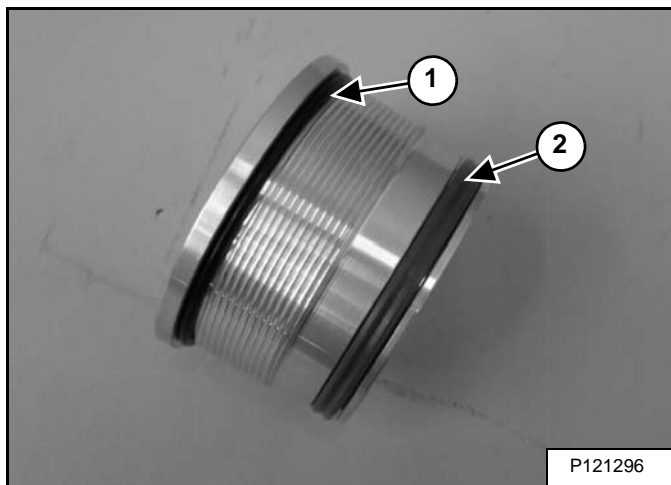

Remove the O-ring (Item 1) and Seal (Item 2) [Figure 20-20-18] from the cylinder head.

**NOTE:** The seal was replaced with an O-ring and back-up O-ring. Use the version currently supplied through parts.

Figure 20-20-19

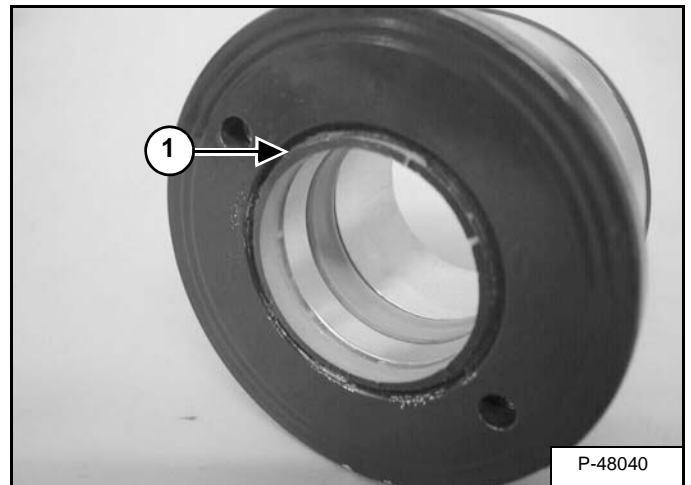

Remove the wiper seal (Item 1) [Figure 20-20-19] from the cylinder head.

Figure 20-20-20

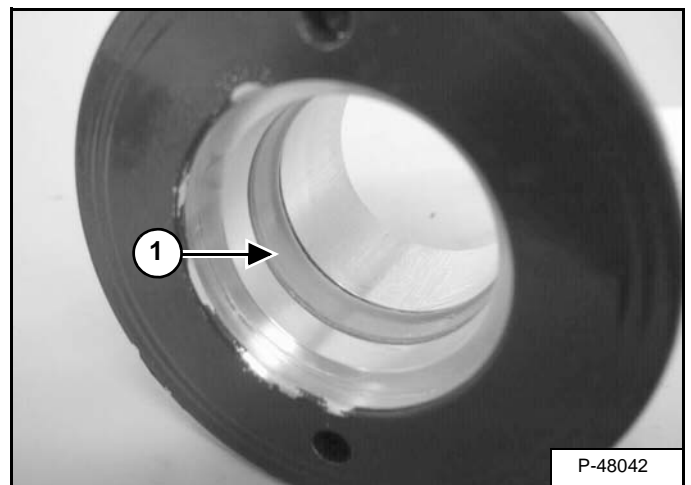

Remove the rod seal (Item 1) [Figure 20-20-20] from the cylinder head.

## CYLINDER (TILT) (CONT'D)

### Disassembly (Cont'd)

Figure 20-21-19

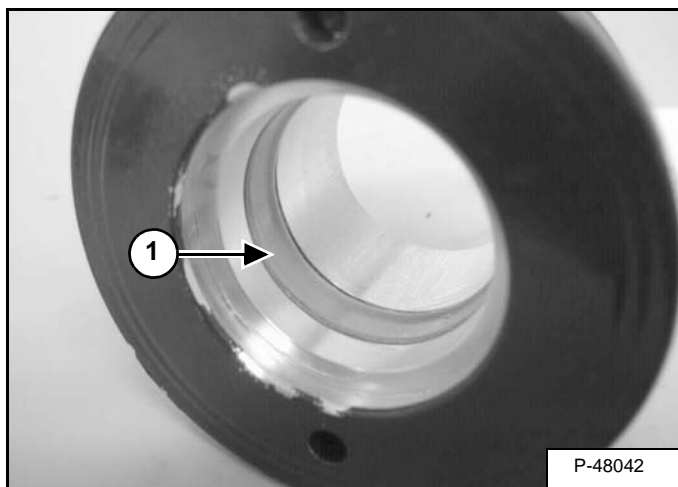

Remove the rod seal (Item 1) [Figure 20-21-19] from the cylinder head.

## CYLINDER (BOB-TACH) (CONT'D)

### Assembly (Cont'd)

Figure 20-22-17

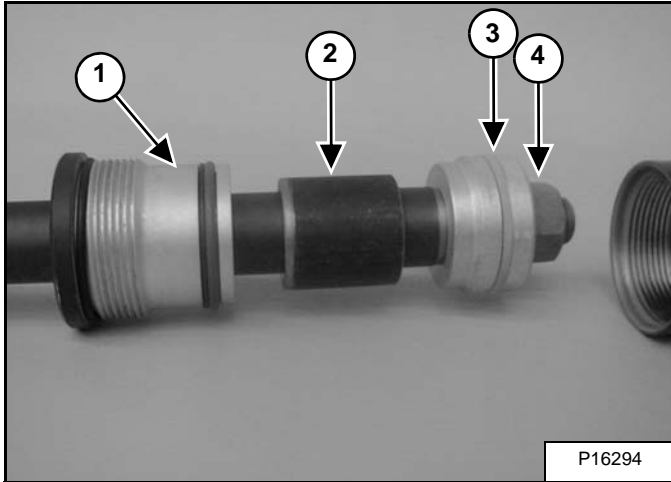

Install the head (Item 1) and spacer (Item 2) [Figure 20-22-17].

Install the piston (Item 3) [Figure 20-22-17].

Grease the piston where the nut contacts the piston. do not get grease on the threads. Install the new nut (Item 4) [Figure 20-22-17].

Tighten the nut to 190 N•m (140 ft-lb) torque.

Figure 20-22-18

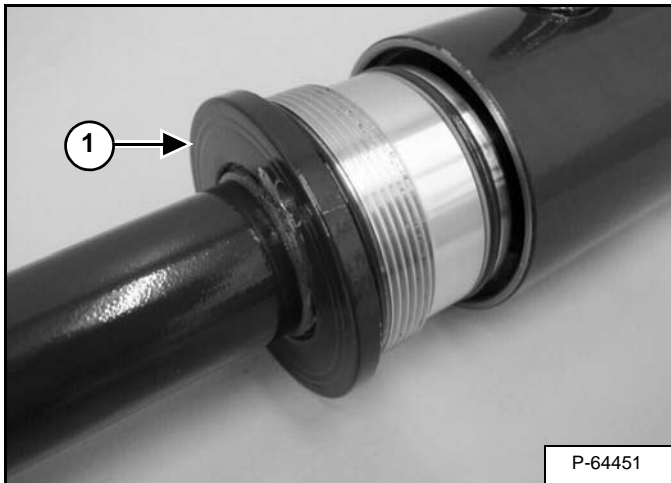

Put the base end of the hydraulic cylinder in a vise.

Using a Gland Nut Wrench, lightly lubricate with grease and tighten the head (Item 1) [Figure 20-22-18] to 183 N•m (135 ft-lb) torque.

**MAIN RELIEF VALVE (S/N A3PG12800 & ABOVE AND S/N A3PH12326 & ABOVE) (CONT'D)**

**Main Relief Valve Removal And Installation (Cont'd)**

**Figure 20-31-9**

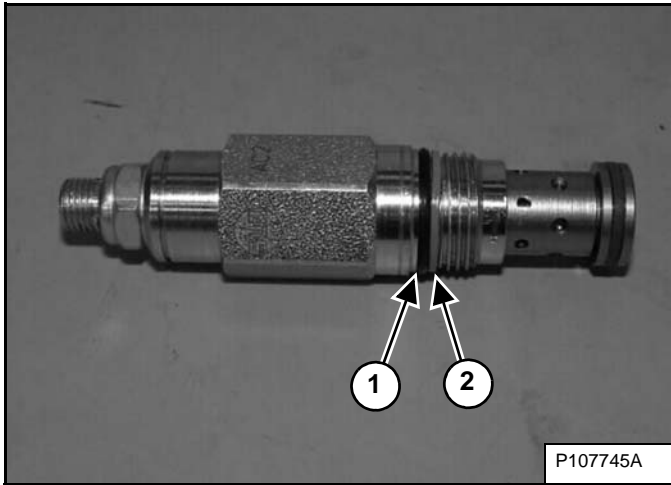

Remove the O-ring (Item 1) and back-up ring (Item 2) [Figure 20-31-9] from the relief valve.

Clean the relief valve in clean solvent. Use air pressure to dry the valve.

Install a new O-ring (Item 1) and back-up ring (Item 2) [Figure 20-31-9]. Install the main relief valve and tighten.

**Installation:** Tighten the relief valve to 51 - 62 N•m (38 - 45 ft-lb) torque.

Test the relief valve. (See Testing on Page 20-31-1.)

**Auxiliary Relief Valve Adjustment**

**NOTE:** This procedure is for loaders equipped with SJC or SCPA controls. The auxiliary relief valve is located in the same place on all of the loaders.

**Figure 20-31-10**

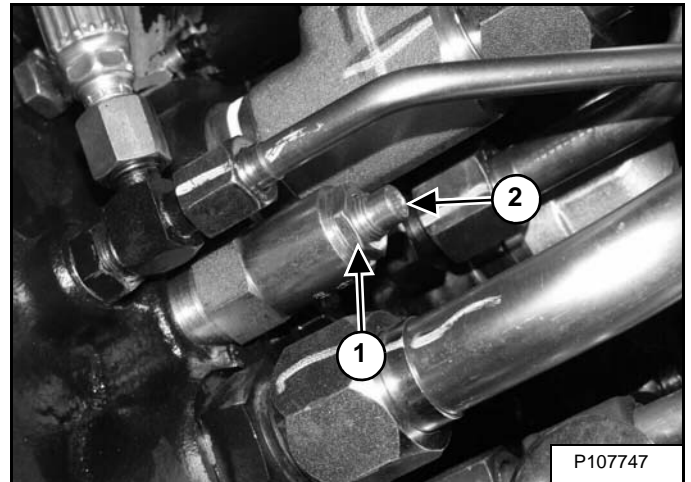

Loosen the locknut (Item 1) [Figure 20-31-10].

Turn the adjustment screw (Item 2) [Figure 20-31-10] in or out until the pressure is correct. Turning the screw in will increase pressure.

**NOTE:** If the correct pressure can not be reached, replace the auxiliary relief valve. Test the pressure setting of the new relief valve.

Identification Chart

Figure 20-40-28

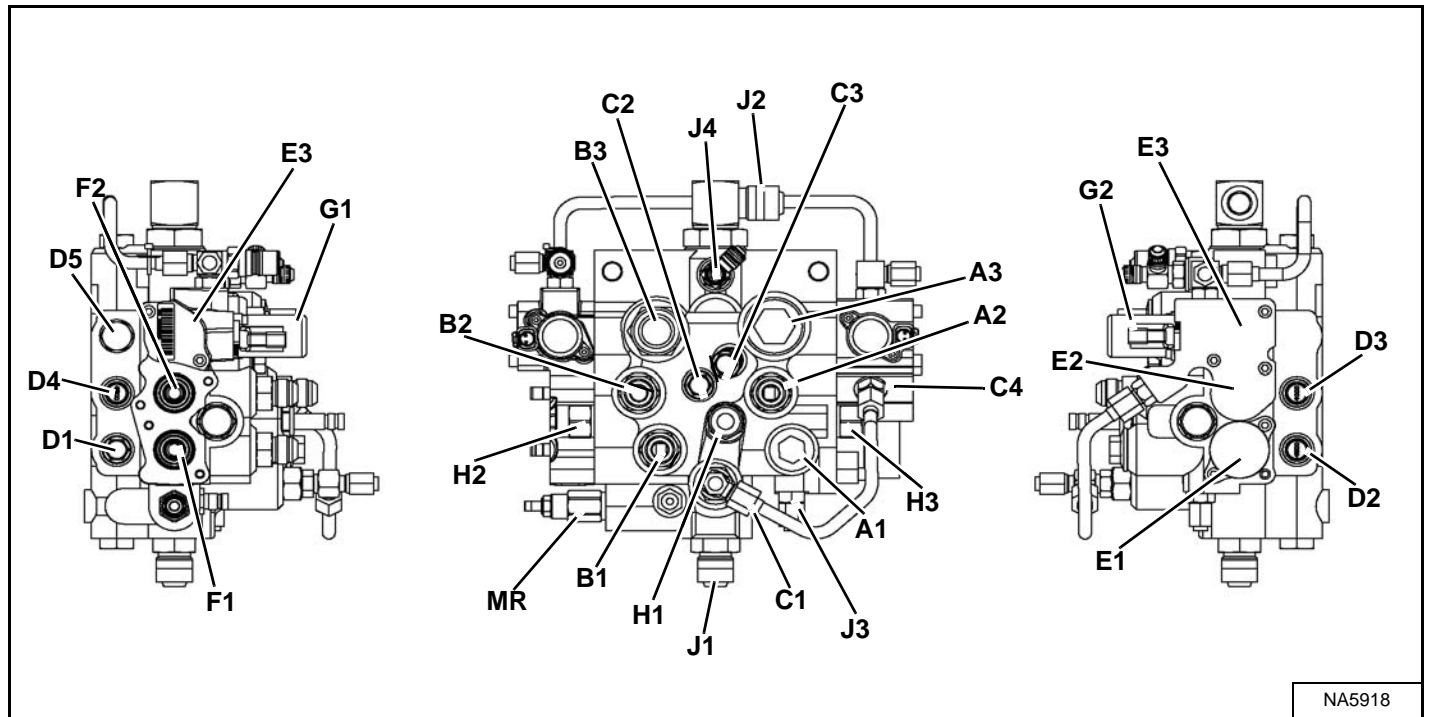

NA5918

ITEM	DESCRIPTION
A1	Lift Cylinder Base End
A2	Tilt Cylinder Base End
A3	Auxiliary Hydraulics Female Coupler
B1	Lift Cylinder Rod End
B2	Tilt Cylinder Rod End
B3	Auxiliary Hydraulics Male Coupler
C1	Load Check
C2	Load Check Valve Tilt Function
C3	Load Check Valve Auxiliary Function
C4	Check Valve
D1	Anti-Cavitation Valve Lift (Rod End)
D2	Port Relief / Anti-Cavitation Valve – 27579 kPa (276 bar) (4000 psi) Lift (Base End)
D3	Port Relief / Anti-Cavitation Valve – 27579 kPa (276 bar) (4000 psi) Tilt (Base End)
D4	Port Relief / Anti-Cavitation Valve – 27579 kPa (276 bar) (4000 psi) Tilt (Rod End)

ITEM	DESCRIPTION
D5	Port Relief / Anti-Cavitation Valve (Auxiliary) 27579 kPa (276 bar) (4000 psi) (Optional)
E1	Lift Spool Detent
E2	Tilt Spool Centering Spring
E3	Auxiliary Spool / Centering Springs
F1	Lift Spool
F2	Tilt Spool
G1	Auxiliary Solenoid Stem
G2	Auxiliary Solenoid Stem
H1	BICS™ Solenoid
H2	BICS™ Lock Valve (Tilt)
H3	BICS™ Lock Valve (Lift)
J1	Inlet Fluid Flow (From Pump)
J2	Outlet Fluid Flow (Return to Tank)
J3	Lift Arm Bypass Orifice
J4	Drain (Case)
MR	Main Relief Valve – 27579 kPa (276 bar) (4000 psi)

**HYDRAULIC CONTROL VALVE (SJC) (S/N A3PG11001 - A3PG12799 AND S/N A3PH11001 - A3PH12325) (CONT'D)**

**Tilt Spool Disassembly And Assembly**

**Figure 20-40-72**

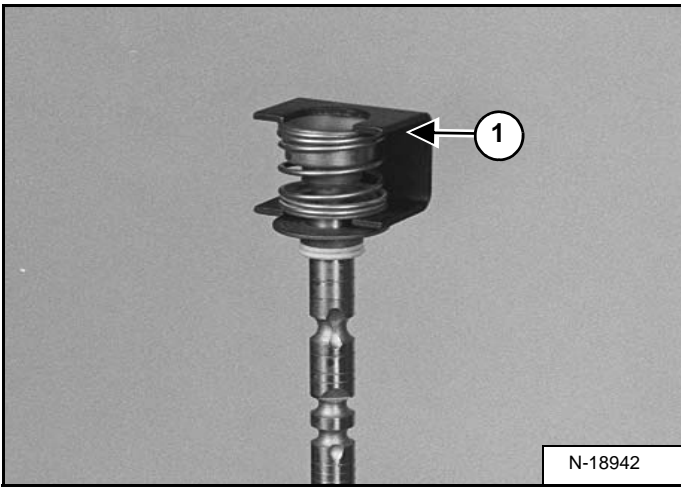

Put the linkage end of the spool in the vise [Figure 20-40-72].

Install the spring tool (Item 1) [Figure 20-40-72] over the centering spring.

**Figure 20-40-73**

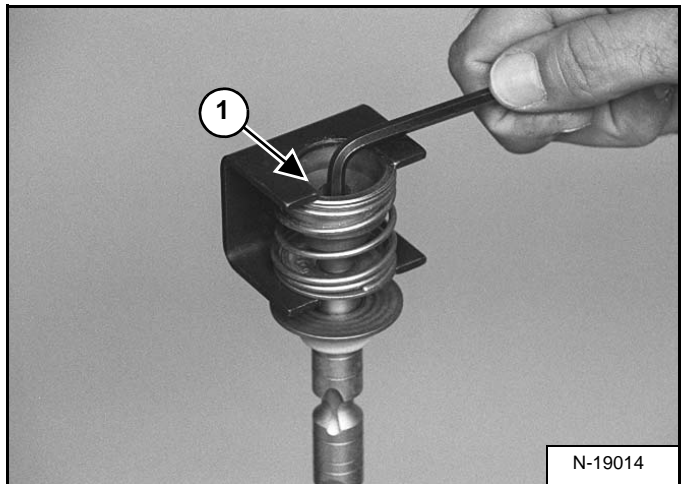

Remove the bolt (Item 1) [Figure 20-40-73] holding the centering spring to the spool.

**Installation:** Tighten the bolt to 10,2 - 11,3 N•m (90 - 100 in-lb) torque.

Remove spring tool from the spring assembly.

**Figure 20-40-74**

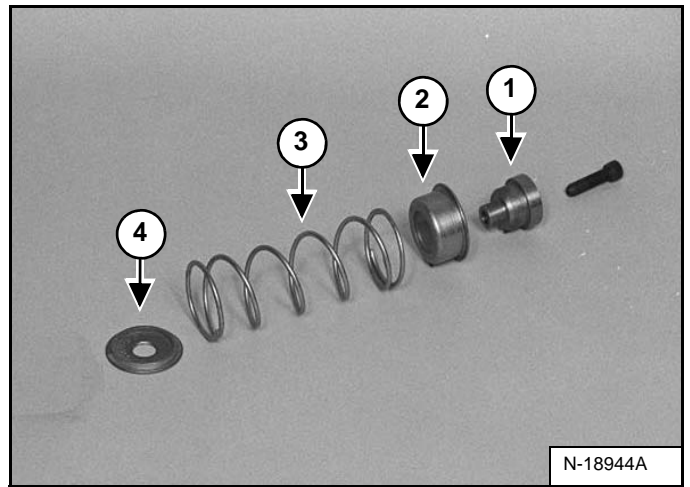

Inspect the adapter (Item 1), collar (Item 2), spring (Item 3) and washer (Item 4) [Figure 20-40-74].

**Figure 20-40-75**

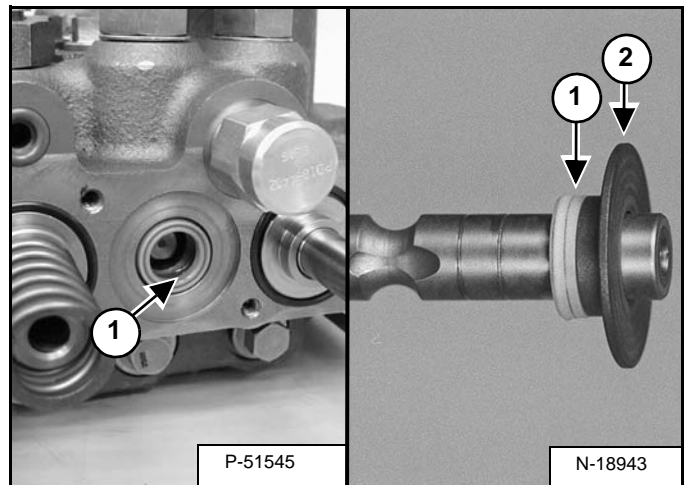

Remove the spool seal(s) (Item 1) and the back-up ring (Item 2) [Figure 20-40-75].

**Assembly:** Always use a new spool seal.

**HYDRAULIC CONTROL VALVE (SJC) (S/N  
A3PG12800 & ABOVE AND A3PH12326 & ABOVE)  
(CONT'D)**

**Removal And Installation (Cont'd)**

**Figure 20-41-13**

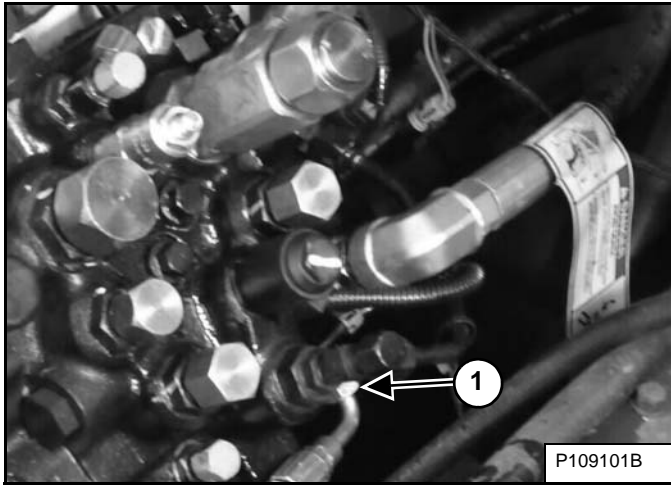

Disconnect the lift arm bypass drain hose (Item 1) [Figure 20-41-13] from the control valve.

**Figure 20-41-14**

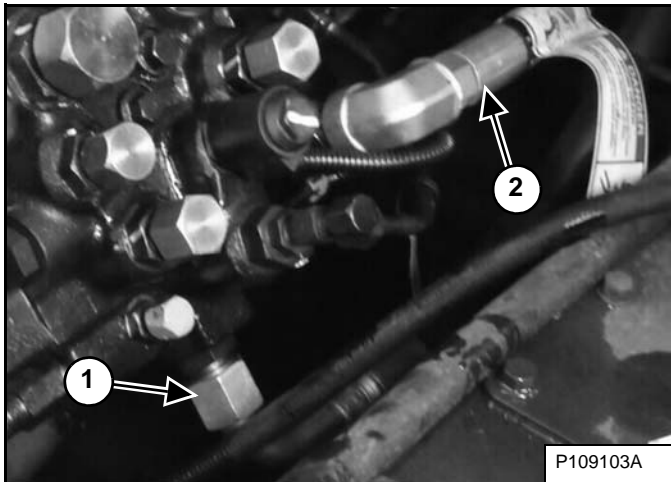

Disconnect the hose (Item 1) [Figure 20-41-14] that routes from the bottom of the control valve to the outlet fitting of the hydraulic pump.

Disconnect the hose (Item 2) [Figure 20-41-14] that routes from the control valve to the junction block at the rear of the machine.

**Figure 20-41-15**

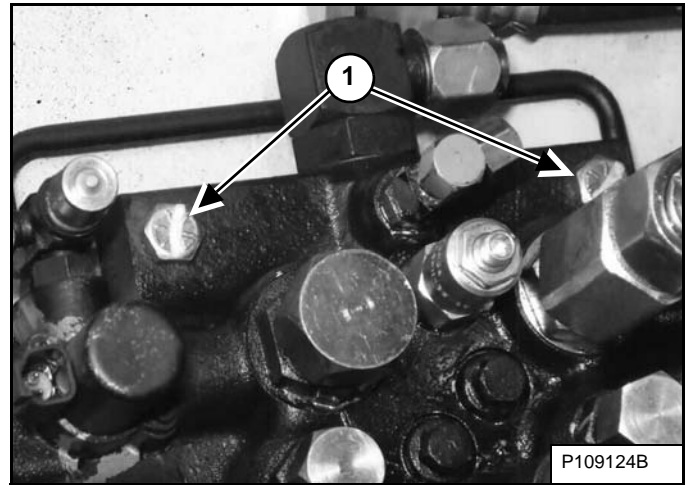

Support the control valve and remove the two bolts (Item 1) [Figure 20-41-15].

Remove the control valve from the loader.

**HYDRAULIC CONTROL VALVE (SJC) (S/N  
A3PG12800 & ABOVE AND A3PH12326 & ABOVE)  
(CONT'D)**

**Plug Removal And Installation**

**Figure 20-41-53**

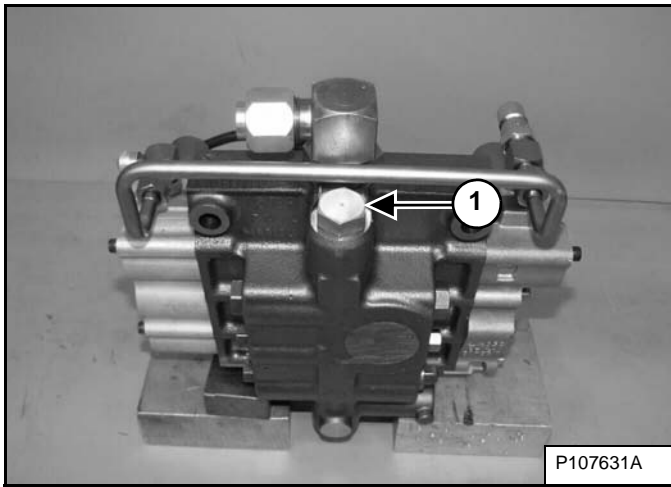

At the top side of the control valve, remove the plug (Item 1) [Figure 20-41-53].

**Figure 20-41-54**

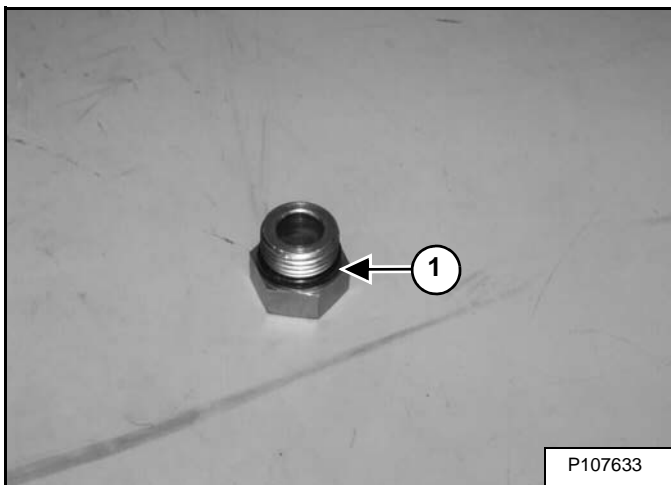

Remove the O-ring (Item 1) [Figure 20-41-54] from the plug.

**Installation:** Replace O-ring, lightly lubricate with oil and tighten to 81,3 N•m (60 ft-lb) torque.

**Figure 20-41-55**

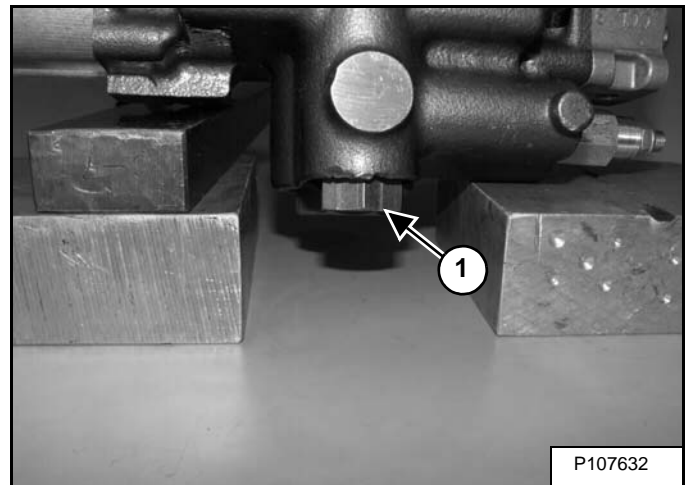

At the bottom side of the control valve remove the plug (Item 1) [Figure 20-41-55].

**Figure 20-41-56**

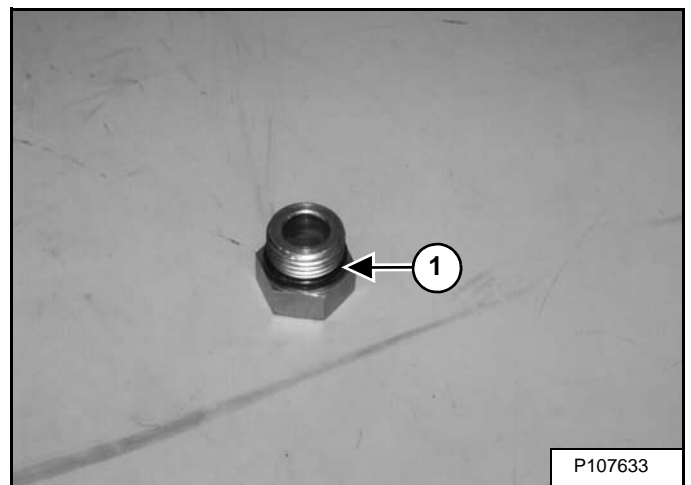

Remove the O-ring (Item 1) [Figure 20-41-56] from the plug.

**Installation:** Replace O-ring, lightly lubricate with oil and tighten to 81,3 N•m (60 ft-lb) torque.

**HYDRAULIC CONTROL VALVE (SJC) (S/N  
A3PG12800 & ABOVE AND A3PH12326 & ABOVE)  
(CONT'D)**

**Auxiliary Relief Valve Removal And Installation**

**Figure 20-41-98**

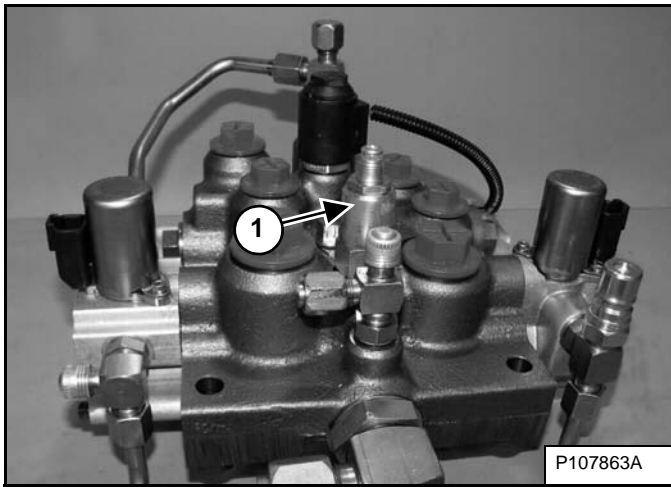

Remove the auxiliary relief valve (Item 1) [Figure 20-41-98].

**Figure 20-41-99**

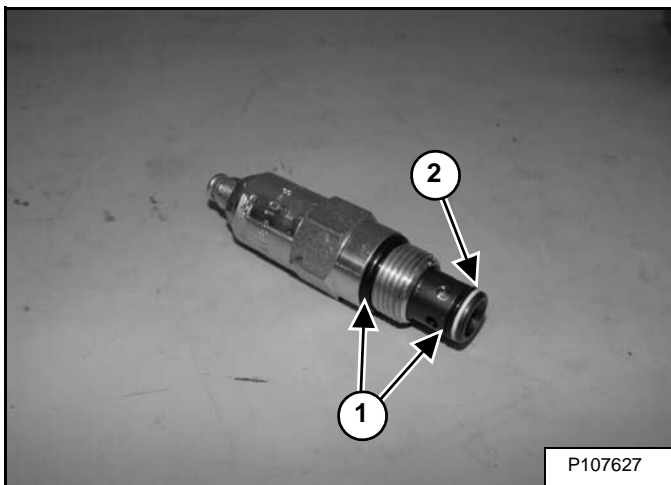

Remove the O-rings (Item 1) [Figure 20-41-99] and back-up ring (Item 2) [Figure 20-41-99] from the auxiliary relief valve.

**Installation:** Replace O-rings and back-up ring, lightly lubricate with oil and tighten to 51 - 61 N•m (38 - 45 ft-lb) torque.

**Check Valve Removal And Installation**

**Figure 20-41-100**

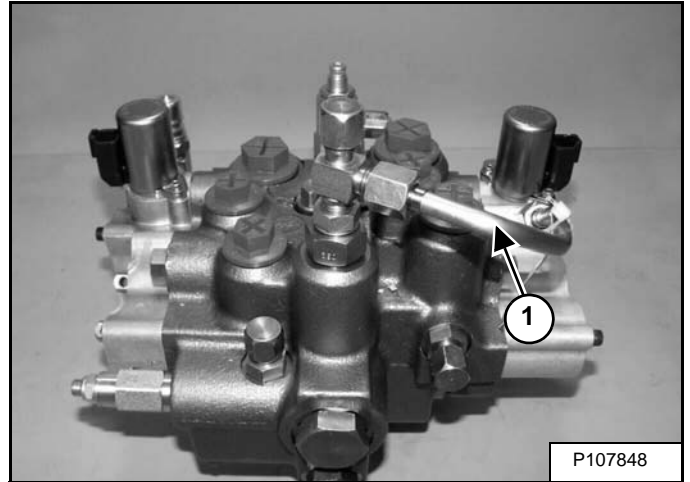

Remove the tubeline (Item 1) [Figure 20-41-100].

**Figure 20-41-101**

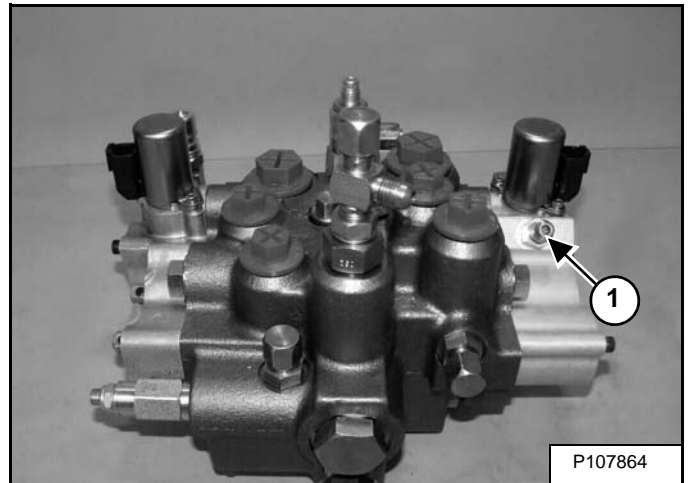

Remove the check valve fitting (Item 1) [Figure 20-41-101] from the hydraulic control valve.

**HYDRAULIC CONTROL VALVE (SCPA) (S/N A3PG11001 - A3PG12799 AND S/N A3PH11001 - A3PH12325) (CONT'D)**

**Port Relief / Anti-Cavitation Valve Removal And Installation (Tilt, Base End)**

**Figure 20-42-27**

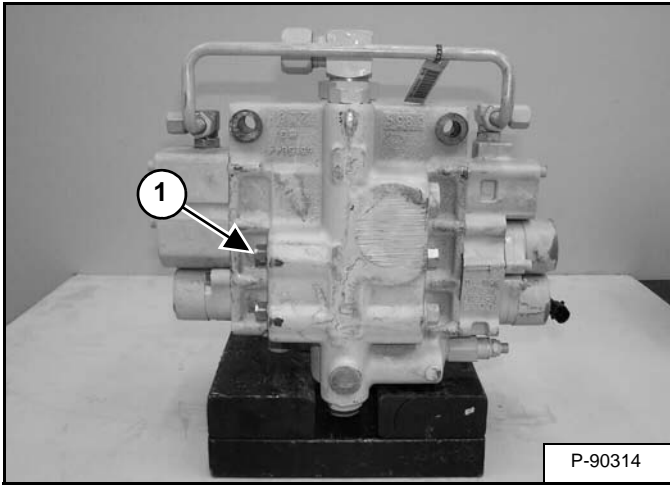

Remove the tilt port relief / anti-cavitation valve (Item 1) [Figure 20-42-27] from the base end of the tilt section.

**Figure 20-42-28**

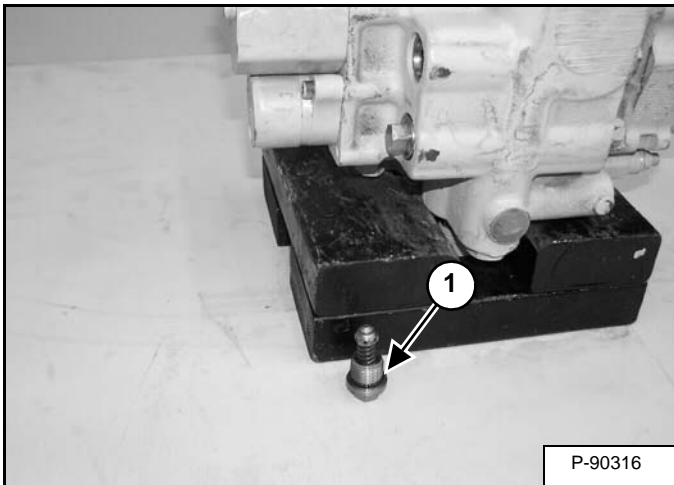

Replace the O-ring (Item 1) [Figure 20-42-28] before installation.

**Installation:** Tighten to 52 - 61 N•m (38 - 45 ft-lb) torque.

**Port Relief / Anti-Cavitation Valve Removal And Installation (Tilt, Rod End)**

**Figure 20-42-29**

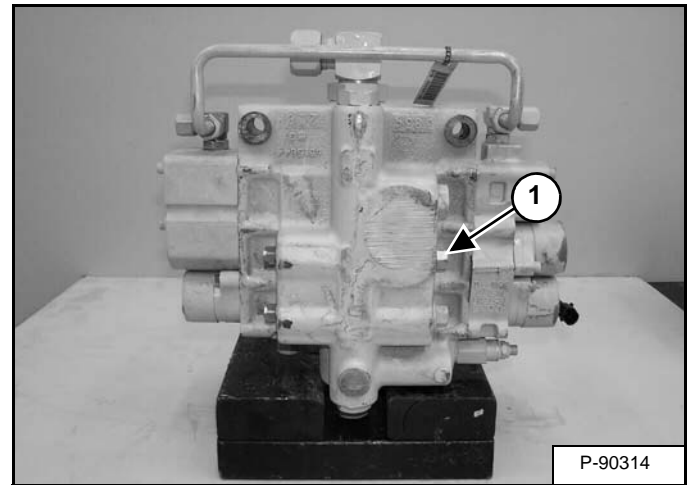

Remove the tilt port relief / anti-cavitation valve (Item 1) [Figure 20-42-29] from the rod end of the tilt section.

**Figure 20-42-30**

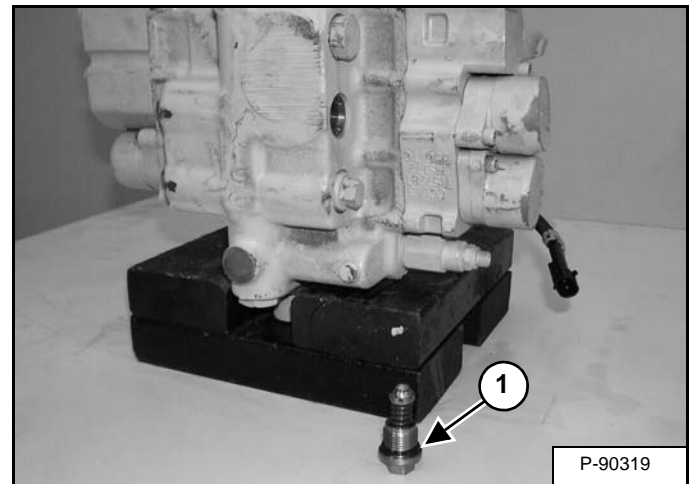

Replace the O-ring (Item 1) [Figure 20-42-30] before installation.

**Installation:** Tighten to 52 - 61 N•m (38 - 45 ft-lb) torque.

**HYDRAULIC CONTROL VALVE (SCPA) (S/N A3PG11001 - A3PG12799 AND S/N A3PH11001 - A3PH12325) (CONT'D)**

**Lift Spool And Detent Removal And Installation (Cont'd)**

**Figure 20-42-72**

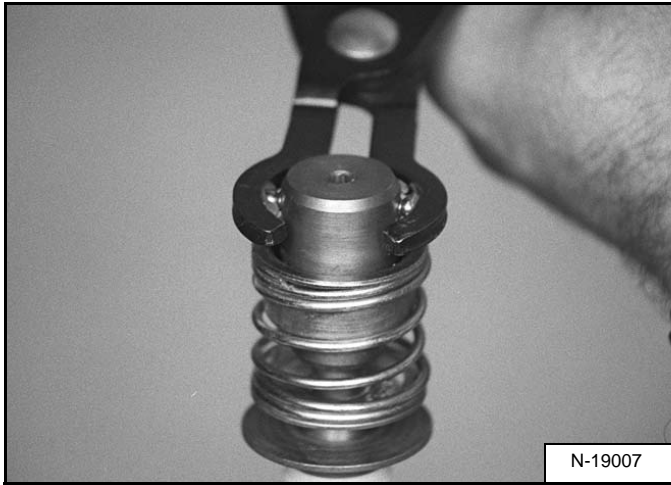

Hold the detent balls in place with the detent pliers [Figure 20-42-72].

**Figure 20-42-73**

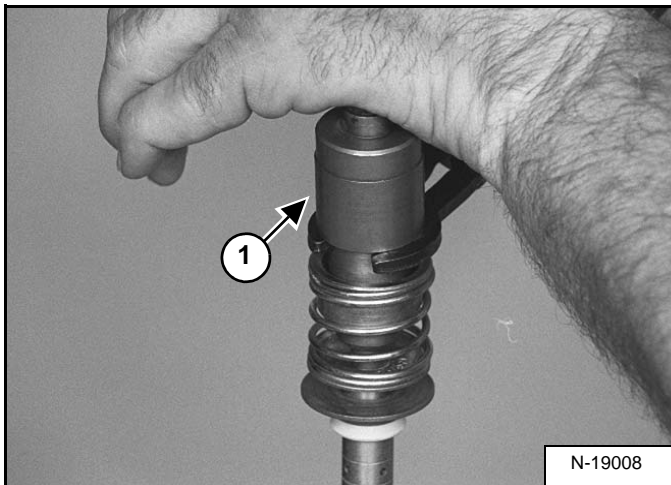

Install the detent sleeve (Item 1) [Figure 20-42-73] to the detent adapter.

**Figure 20-42-74**

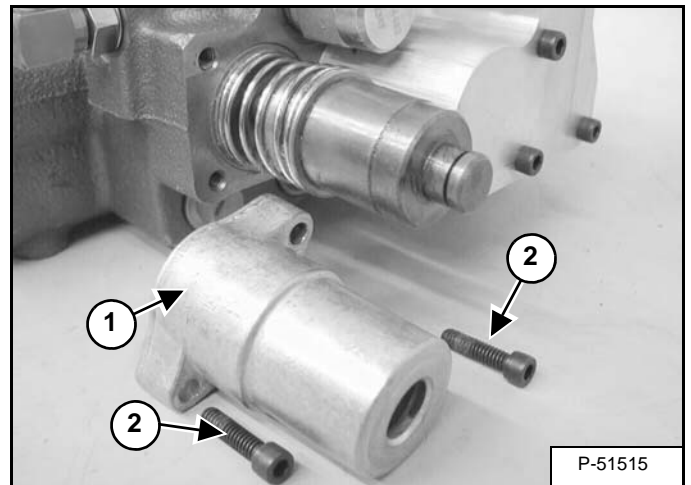

Install the lift spool assembly in the spool bore [Figure 20-42-74].

Install the detent bonnet (Item 1) [Figure 20-42-74].

Install the mounting screws (Item 2) [Figure 20-42-74].

**Installation:** Lubricate the screws and tighten to 10,7 - 11,9 N•m (95 - 105 in-lb) torque.

**Figure 20-42-75**

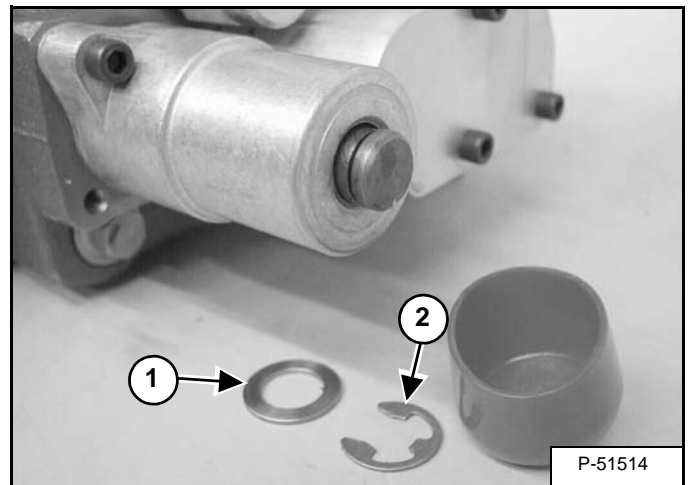

Install the washer (Item 1) and snap ring (Item 2) [Figure 20-42-75].

**HYDRAULIC CONTROL VALVE (SCPA) (S/N A3PG11001 - A3PG12799 AND S/N A3PH11001 - A3PH12325) (CONT'D)**

**Check Valve Removal And Installation**

**Figure 20-42-114**

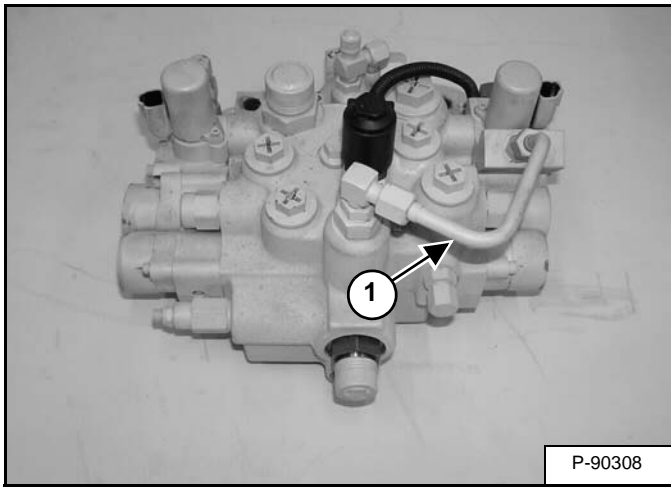

Remove the tubeline (Item 1) [Figure 20-42-114].

**Figure 20-42-115**

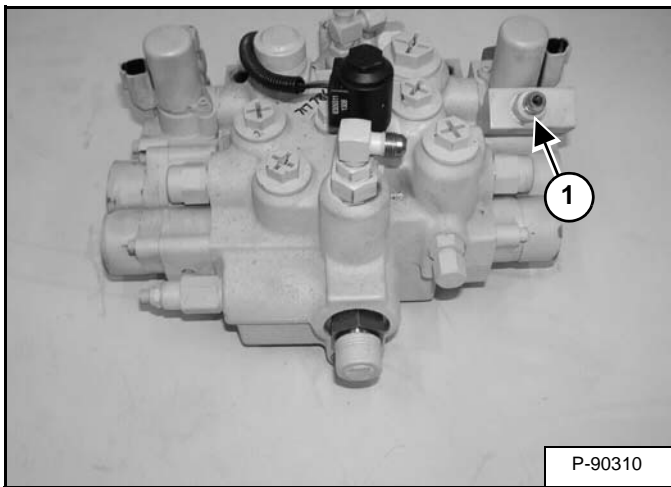

Remove the check valve fitting (Item 1) [Figure 20-42-115] from the hydraulic control valve.

**Figure 20-42-116**

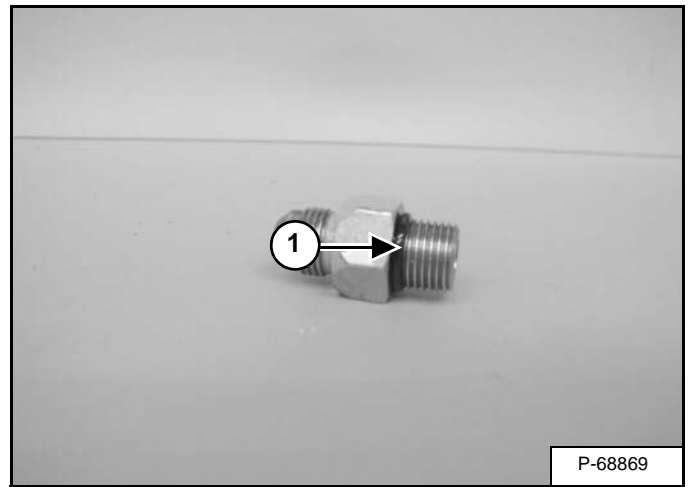

Remove the O-ring (Item 1) [Figure 20-42-116].

**Installation:** Lubricate the O-ring (Item 1) [Figure 20-42-116] and tighten the fitting to 27 - 33 N•m (20 - 24 ft-lb) torque.

**Figure 20-42-117**

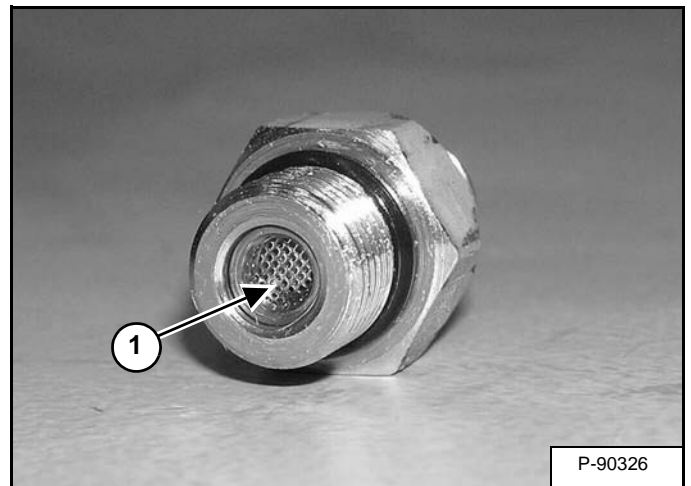

Inspect the screen (Item 1) [Figure 20-42-117].

**HYDRAULIC CONTROL VALVE (SCPA) (S/N A3PG12800 & ABOVE AND S/N A3PH12326 & ABOVE) (CONT'D)**

**Port Relief Valve Removal And Installation**

**Figure 20-43-31**

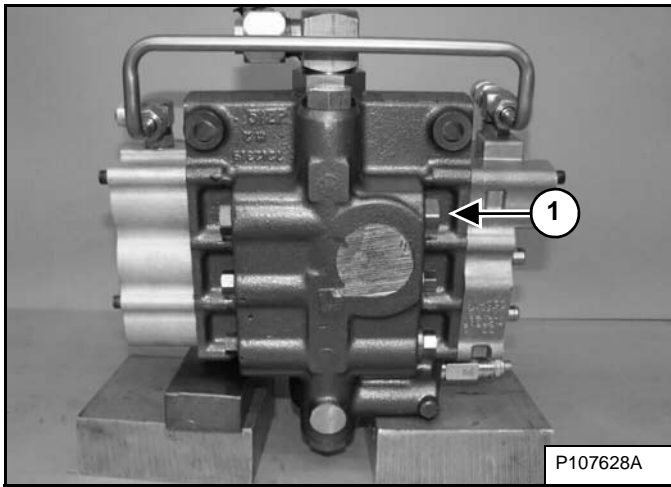

Remove the port relief plug (Item 1) [Figure 20-43-31] from the auxiliary circuit of the control valve.

**Figure 20-43-32**

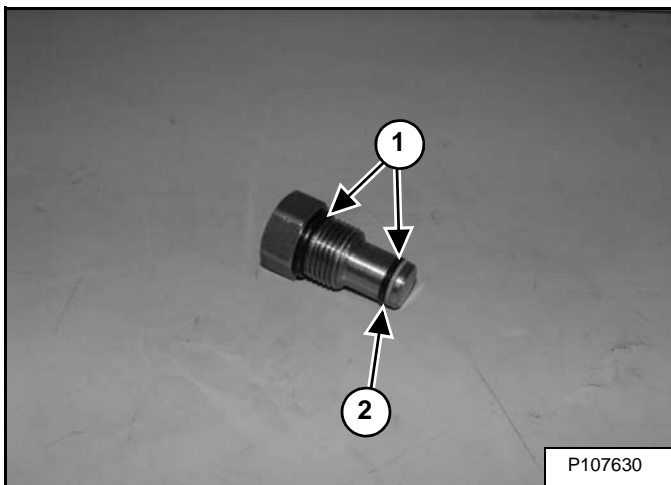

Remove the O-rings (Item 1) and back-up ring (Item 2) [Figure 20-43-32] from the port relief plug.

**Installation:** Replace O-rings and back-up ring, lightly lubricate with oil and tighten to 51 - 61 N•m (38 - 45 ft-lb) torque.

**Figure 20-43-33**

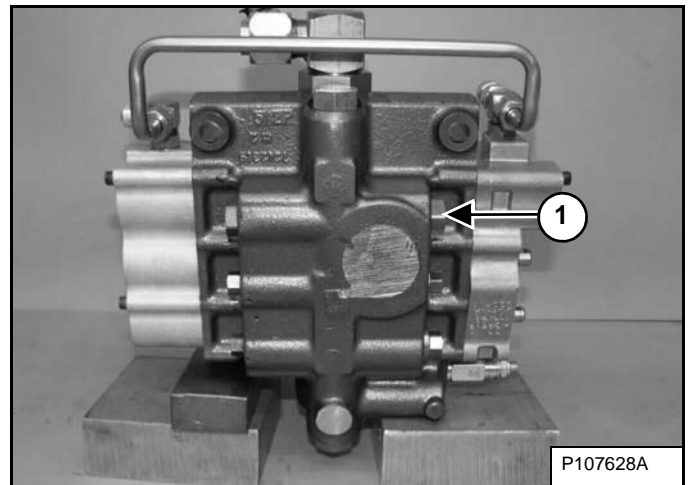

The control valve may be equipped with an optional auxiliary port relief valve (Item 1) [Figure 20-43-33].

Remove the auxiliary port relief valve.

**Figure 20-43-34**

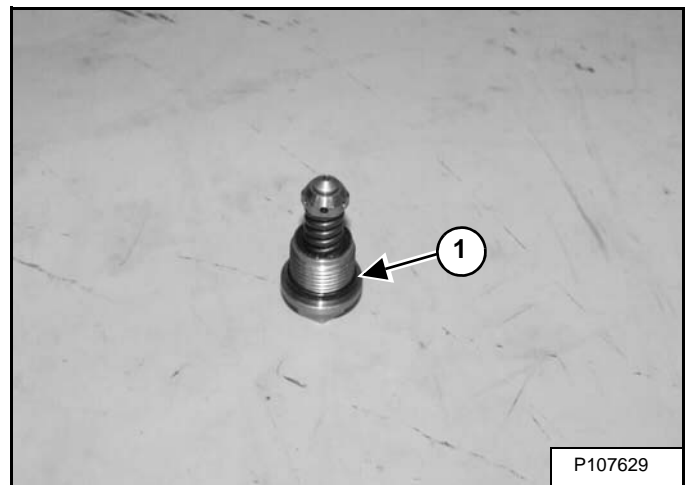

Remove the O-ring (Item 1) [Figure 20-43-34] from the port relief / anti-cavitation relief valve.

**Installation:** Replace O-ring, lightly lubricate with oil and tighten to 51 - 61 N•m (38 - 45 ft-lb) torque.

**HYDRAULIC CONTROL VALVE (SCPA) (S/N A3PG12800 & ABOVE AND S/N A3PH12326 & ABOVE) (CONT'D)**

**Tilt Spool Removal And Installation**

Remove the end cap block. (See End Cap Block Removal And Installation on Page 20-43-14.)

**Figure 20-43-77**

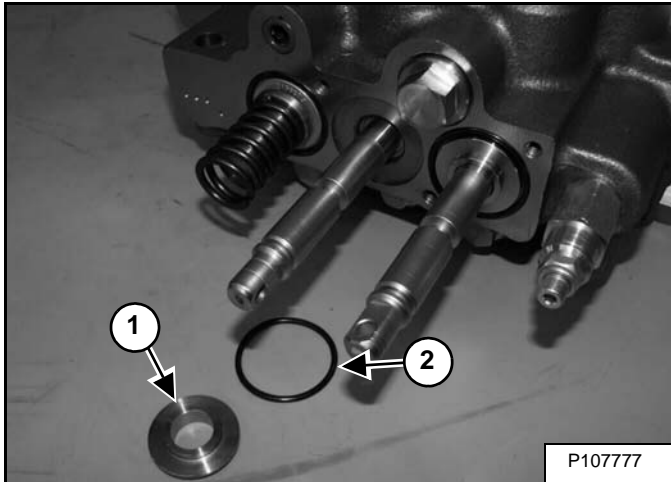

Remove the spacer (Item 1) and O-ring (Item 2) [Figure 20-43-77] from the tilt spool.

**Figure 20-43-78**

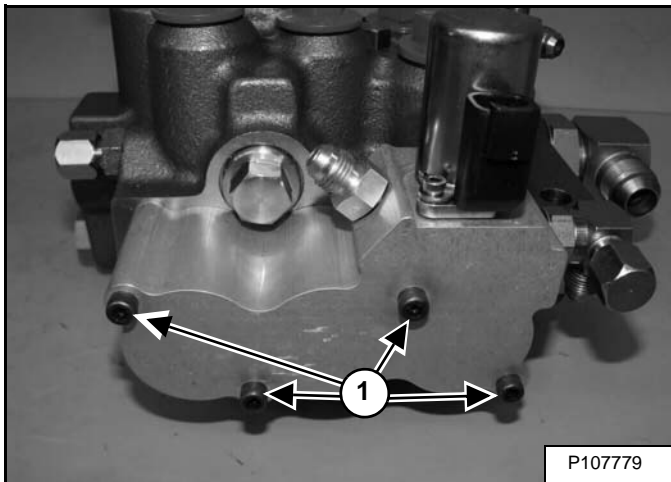

Remove the four screws (Item 1) [Figure 20-43-78] from the spool centering block.

**Installation:** Lubricate the screws and tighten to 10,4 - 11,6 N•m (95 - 105 in-lb) torque.

**Figure 20-43-79**

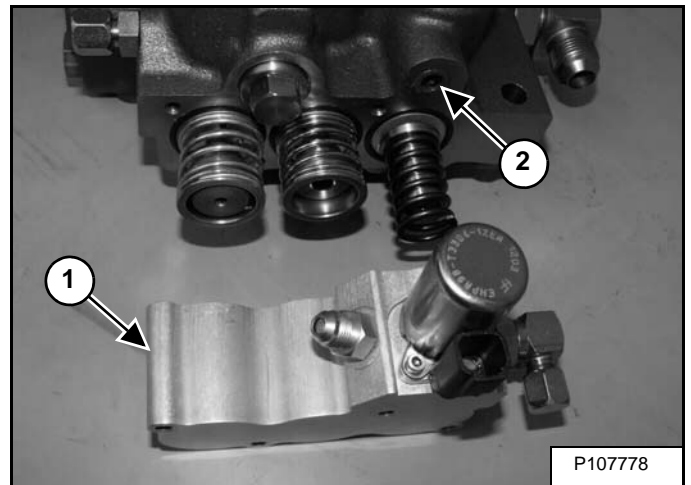

Remove the spool centering block (Item 1) [Figure 20-43-79] from the control valve.

**Installation:** Replace the O-ring (Item 2) [Figure 20-43-79] and lubricate the O-ring lightly with grease or oil before installation of the spool centering block.

**Figure 20-43-80**

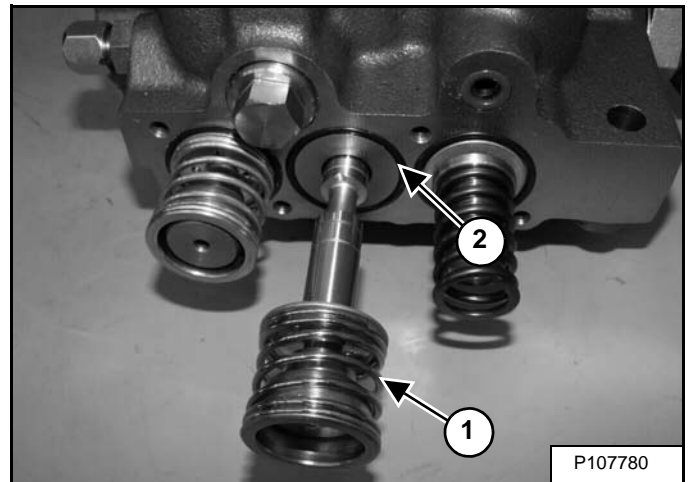

Remove the tilt spool (Item 1) and O-ring (Item 2) [Figure 20-43-80].

**Installation:** Replace the O-ring (Item 2) [Figure 20-43-80] and lubricate the O-ring lightly with grease or oil before installation of the spool centering block.

## LIFT ARM BYPASS CONTROL VALVE (CONT'D)

### Bracket Removal And Installation

Figure 20-50-4

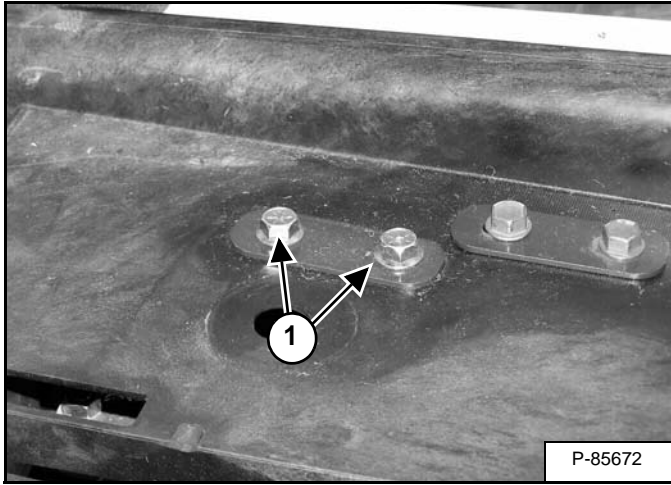

Remove the two bolts (Item 1) [Figure 20-50-4] to replace the bypass valve mounting bracket if necessary.

## Disassembly And Assembly

Figure 20-50-5

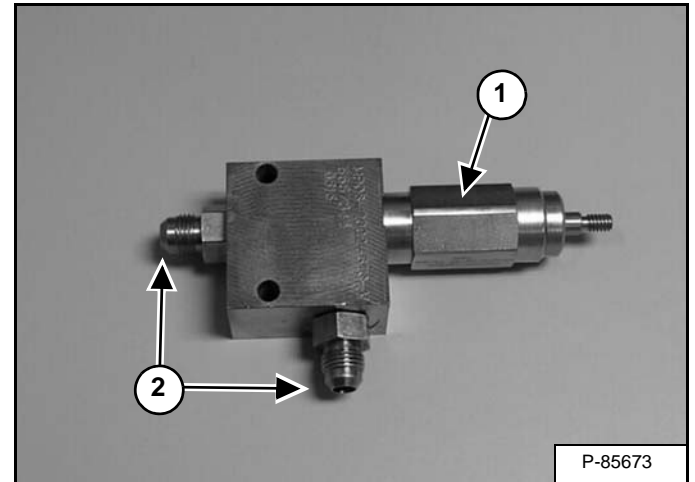

Remove the lift arm bypass valve (Item 1) [Figure 20-50-5] from the valve block. Inspect the bypass valve for damage and replace if necessary.

**Installation:** Tighten the valve to 45 - 50 N•m (33 - 37 ft-lb) torque.

Inspect the hydraulic fittings (Item 2) [Figure 20-50-5] on the valve block for damage and replace if necessary.

## HYDRAULIC PUMP (CONT'D)

### Disassembly And Assembly

# IMPORTANT

When repairing hydrostatic and hydraulic systems, clean the work area before disassembly and keep all parts clean. Always use caps and plugs on hoses, tubelines and ports to keep dirt out. Dirt can quickly damage the system.

I-2003-0888

Mark the pump sections for correct assembly.

To disassemble and assemble the hydraulic pump, follow the Parts Identification page (See Parts Identification on Page 20-60-10.) for proper placement of components along with the information below.

**NOTE: A seal kit is available through Bobcat Service Parts.**

**Assembly:** Tighten the eight pump housing bolts (Item 1) [Figure 20-60-14] to 50 N•m (37 ft-lb) torque.

**NOTE: Position the wear plate (Item 5) [Figure 20-60-14] inlets and traps as shown with the bronze side toward the gears on all wear plates.**

Inspect all gears, shafts and pump end sections. If any of these components have excessive wear or damage is visible, the complete pump must be replaced.

## HYDRAULIC PUMP (HIGH FLOW) (CONT'D)

### Removal And Installation (Cont'd)

*Earlier Models*

**Figure 20-61-21**

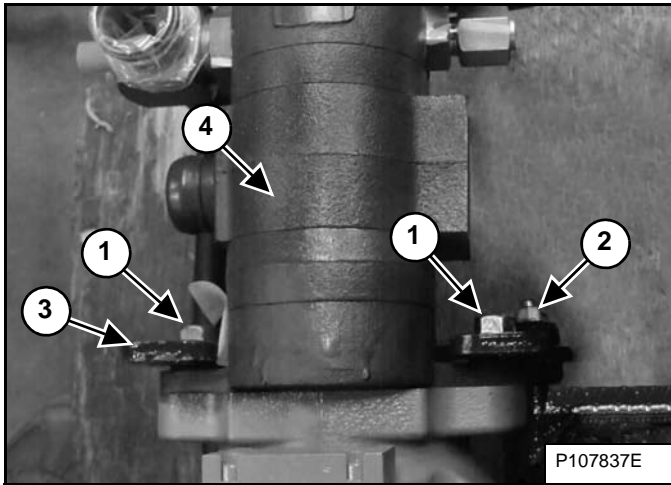

Remove the two mounting bolts (Item 1), nut (Item 2) and mounting plate (Item 3) [Figure 20-61-21] from the hydraulic pump.

Remove the hydraulic pump (Item 4) [Figure 20-61-21] from the loader.

**Installation:** Tighten the mounting bolts to 75 - 85 N•m (55 - 60 ft-lb) torque.

**Installation:** Tighten nut (Item 2) [Figure 20-61-21] to 38 N•m (28 ft-lb) torque.

*Later Models*

**Figure 20-61-22**

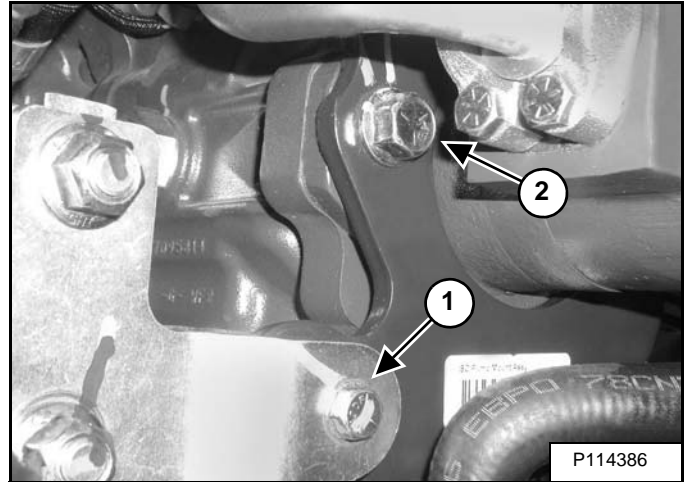

Remove the bracket mounting bolt / nut (Item 1) [Figure 20-61-22].

**Installation:** Tighten the bolt / nut to 34 - 38 N•m (25 - 28 ft-lb) torque.

**Figure 20-61-23**

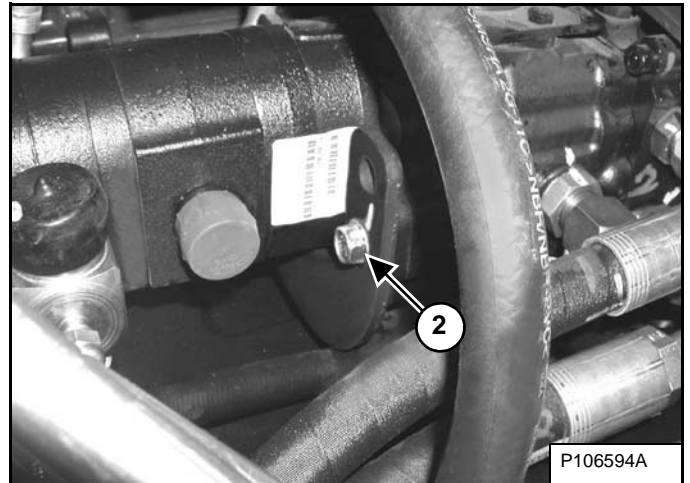

Remove the two mounting bolts (Item 2) [Figure 20-61-22] and [Figure 20-61-23].

**Installation:** Tighten the bolts to 75 - 85 N•m (55 - 60 ft-lb) torque.

Remove the hydraulic pump.

## HYDRAULIC FLUID RESERVOIR (LATER MODELS)

### Description

The hydraulic fluid reservoir is a storage container for the loader's hydraulic / hydrostatic fluid. The reservoir contains a vented fill cap with a fluid screen to prevent contaminants from entering the reservoir while adding fluid.

The hydraulic fluid reservoir is located behind the operator's cab under the rear grille on the right side of the loader.

### Removal And Installation

Raise the lift arms and install an approved lift arm support device. (See Installing on Page 10-20-1.)

Raise the operator cab. (See Raising on Page 10-30-2.)

Drain the fluid from the reservoir. (See Removing And Replacing Hydraulic Fluid on Page 10-120-2.)

Remove the Hydraulic / Hydrostatic Filter Housing (See HYDRAULIC / HYDROSTATIC FILTERS (EARLIER MODELS) on Page 20-70-1.) and (See HYDRAULIC / HYDROSTATIC FILTERS (LATER MODELS) on Page 20-71-1.)

Remove the rear grille (See Removing on Page 50-60-1.)

**Figure 20-81-1**

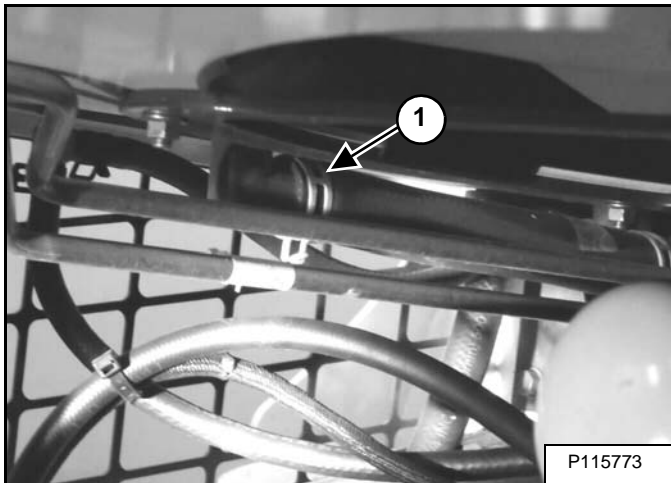

Remove the clamp and the hose (Item 1) [Figure 20-81-1].

**Figure 20-81-2**

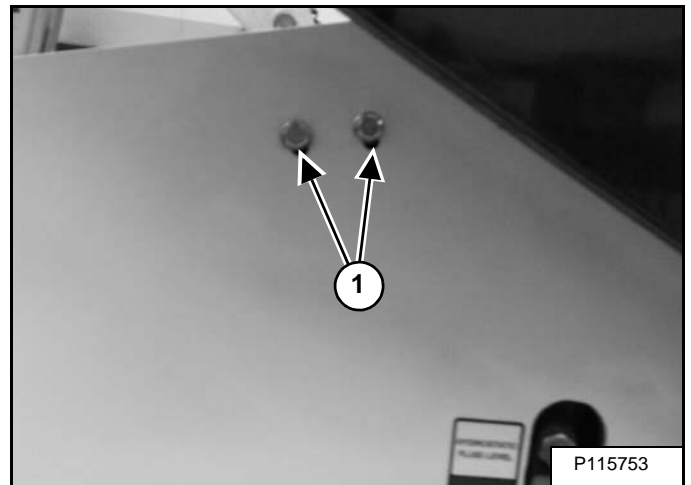

Remove the two bolts (Item 1) [Figure 20-81-2].

Remove the hydraulic fluid reservoir from the loader.

**Installation:** Tighten the mount bolts and nuts to 21,7 - 24,4 N•m (16 - 18 ft-lb) torque.



## BOB-TACH (POWER) BLOCK (EARLIER MODELS) (CONT'D)

### Disassembly And Assembly (Cont'd)

Figure 20-120-10

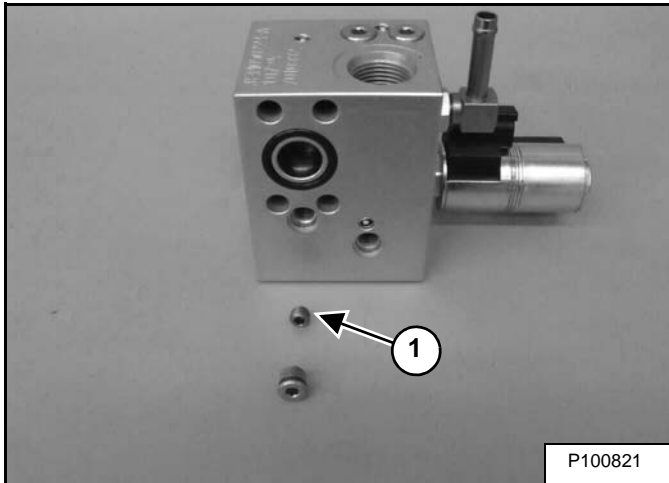

Remove the orifice screw (Item 1) [Figure 20-120-10].

**Installation:** Tighten the orifice screw (Item 1) [Figure 20-120-10] to 8,1 - 10,8 N•m (6 - 8 ft-lb) torque.

Figure 20-120-11

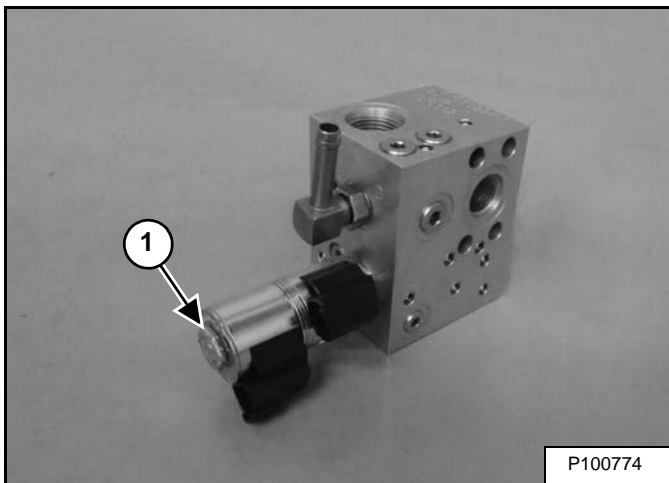

**NOTE:** Remember the solenoid coil orientation for ease of installation.

Remove the solenoid coil nut (Item 1) [Figure 20-120-11].

**Installation:** Tighten the solenoid coil valve stem nut to 6,8 N•m (5 ft-lb) torque.

Figure 20-120-12

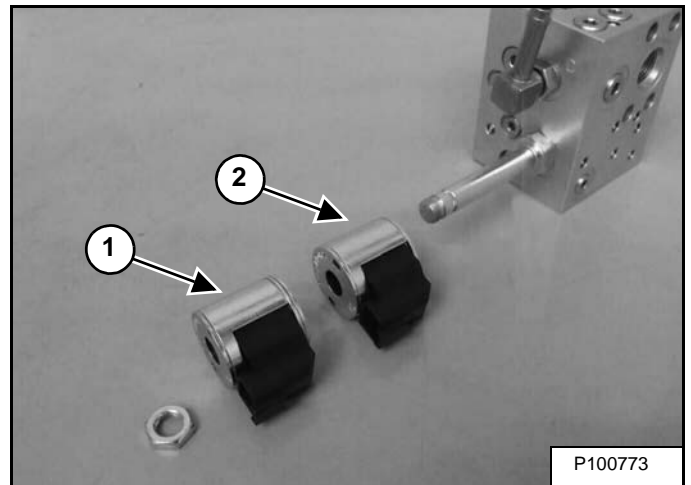

Remove the first solenoid coil (Item 1) and the second solenoid coil (Item 2) [Figure 20-120-12].

Figure 20-120-13

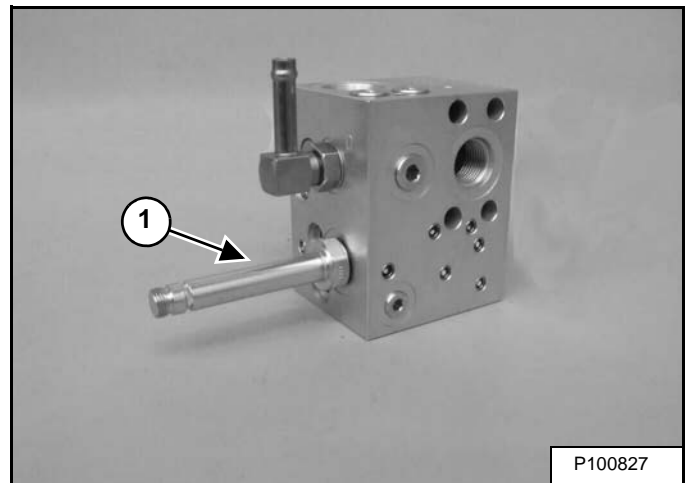

Remove the solenoid coil stem (Item 1) [Figure 20-120-13].

**Installation:** Tighten the solenoid coil stem to 27,14 N•m (20 ft-lb) torque.

## BOB-TACH (POWER) BLOCK (LATER MODELS) (CONT'D)

### Disassembly And Assembly

# IMPORTANT

When repairing hydrostatic and hydraulic systems, clean the work area before disassembly and keep all parts clean. Always use caps and plugs on hoses, tubelines and ports to keep dirt out. Dirt can quickly damage the system.

I-2003-0888

Figure 20-121-8

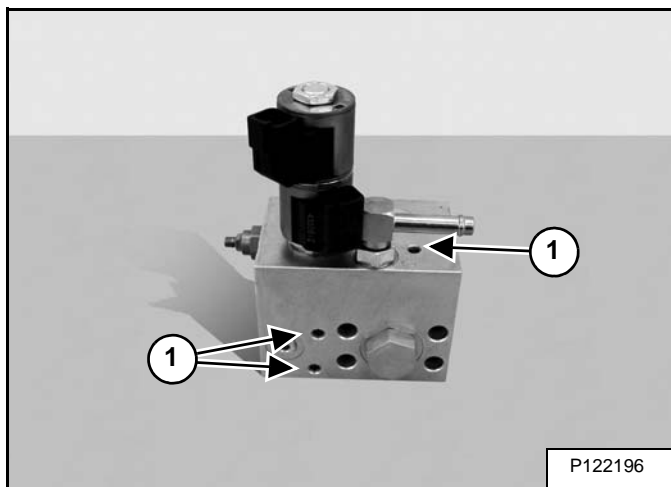

Do not remove these plugs (Item 1) [Figure 20-121-8].

**NOTE:** Do not remove the expander plugs in block (total of 11). A new Power Bob-Tach valve will be required if tampered with. All other plugs can be removed.

Figure 20-121-9

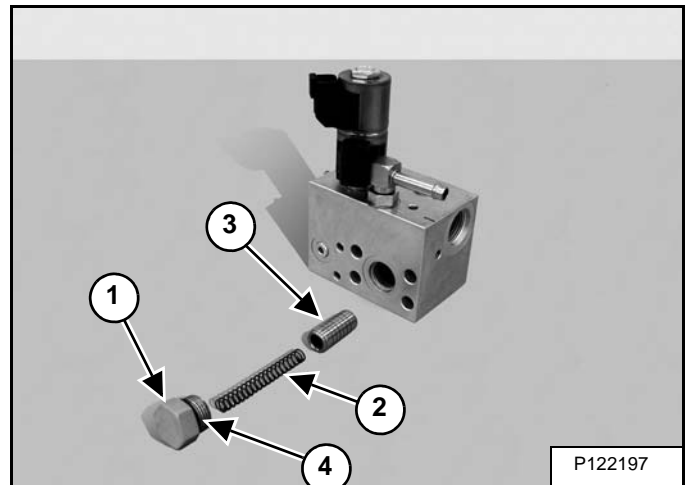

Remove plug (Item 1), spring (Item 2) and spool (Item 3) [Figure 20-121-9] and inspect. Replace damaged parts as needed.

**Installation:** Tighten the plug to 67,8 N•m (50 ft-lb) torque.

Replace the O-ring (Item 4) [Figure 20-121-9] on the plug.

Figure 20-121-10

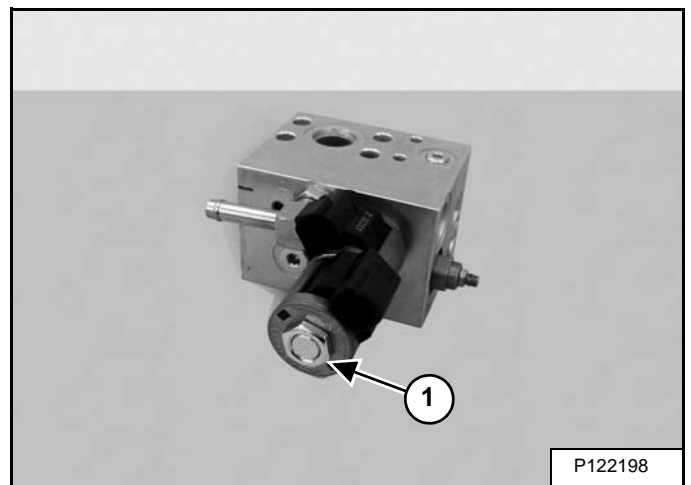

**NOTE:** Mark the solenoid coil orientation for installation.

Remove the coil nut (Item 1) [Figure 20-121-10].

**Installation:** Tighten the solenoid coil valve stem nut to 6,8 N•m (5 ft-lb) torque.

## **AUTOMATIC RIDE CONTROL**

### **Description**

The automatic ride control is an option that provides a smoother ride, reduced load spillage, and improved machine control when traveling over uneven ground with heavy loads or in heavy digging applications.

## HYDROSTATIC DRIVE MOTOR

### Description

The hydrostatic drive motors are driven by the hydrostatic pump. Machines equipped with SJC / SCPA are monitored by a sensor (if equipped) mounted onto the motor housing. The sensor is used for detection of motion and for rate of speed for the SJC / SCPA options.

The hydrostatic drive motors contain a spring applied pressure release braking system. In addition there is a separate oil chamber in the motor that is filled with high performance synthetic oil for maximum durability, this oil has a recommended service interval. (See SERVICE SCHEDULE on Page 10-70-1.)

There are two hydrostatic drive motors and they are located on the track carriage.

**NOTE: One speed motor option is no longer available on later model machines.**

### Removing And Replacing Oil

For the correct service interval (See SERVICE SCHEDULE on Page 10-70-1.)

Park the loader so that the plug in the hydrostatic drive motor is at the bottom.

Remove the plug and let the oil drain from the hydrostatic drive motor.

**Figure 30-20-1**

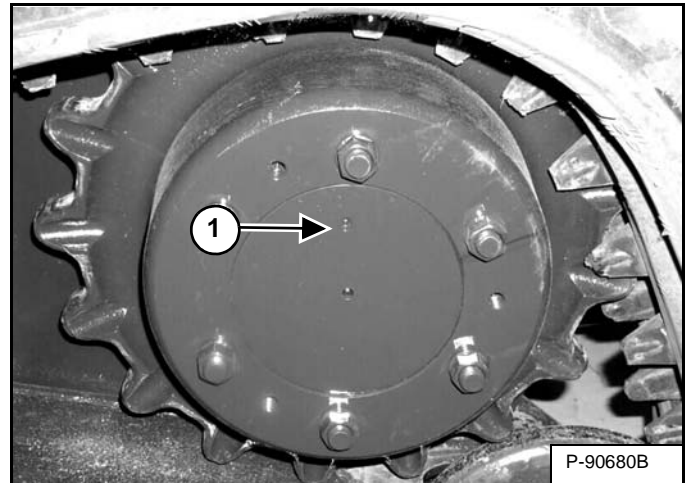

Rotate the hydrostatic drive motor so that the plug (Item 1) [Figure 30-20-1] is at the top. Add high performance synthetic oil (P/N 7024981). (See Capacities on Page SPEC-10-4.)

Clean the threads of the plug and drain hole. Apply Loctite® 243 to the plug threads. Install and tighten the plug.

Repeat for the other hydrostatic drive motor.

Recycle or dispose of the used oil in an environmentally safe manner.

## HYDROSTATIC MOTOR (CONT'D)

### Disassembly And Assembly (Cont'd)

Figure 30-20-31

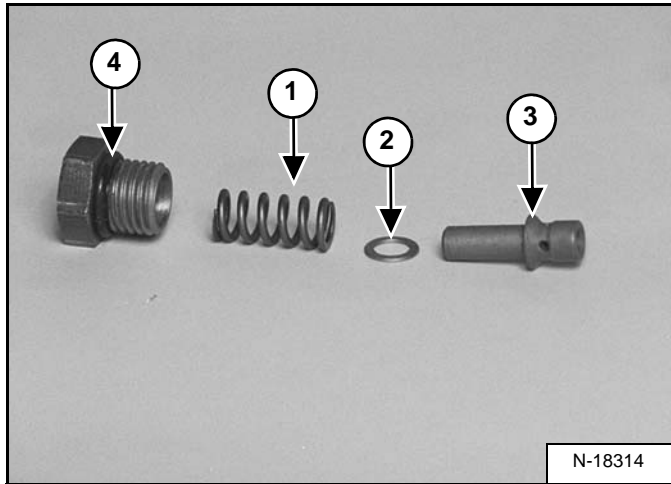

Remove the spring (Item 1) shim (Item 2) and poppet (Item 3) [Figure 30-20-31].

Inspect all parts and replace as needed.

Install a new O-ring (Item 4) [Figure 30-20-31] on the plug before installation.

Figure 30-20-32

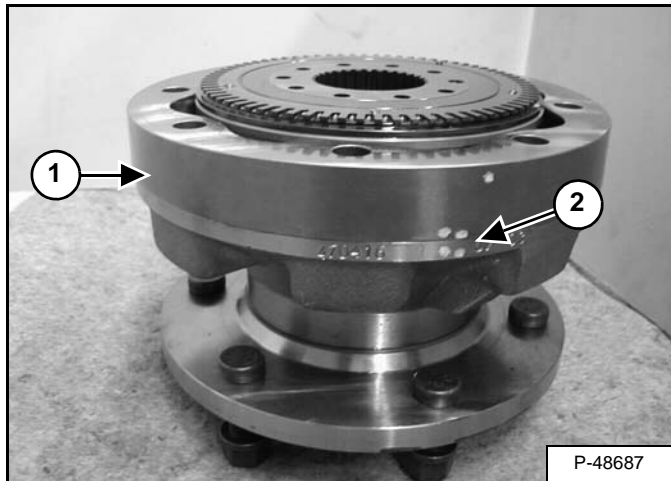

Remove the cam ring (Item 1) [Figure 30-20-32] from the front housing assembly.

Check the cam ring inside surface for wear and scratches.

**Assembly:** Align the marks (Item 2) [Figure 30-20-32] on the cam rings to the front housing.

Figure 30-20-33

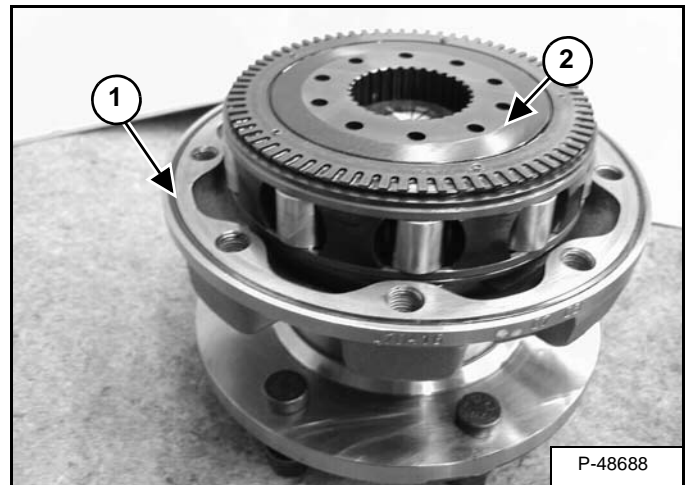

Remove and replace the O-ring (Item 1) [Figure 30-20-33] from the front housing assembly.

**Assembly:** Slightly smear the O-ring (Item 1) [Figure 30-20-33] with grease to hold in place.

Remove the rotating group (Item 2) [Figure 30-20-33] from the front housing assembly.

Figure 30-20-34



Remove the snap ring (Item 1) [Figure 30-20-34] from the bottom side of the rotating group.

**HYDROSTATIC MOTOR (TWO-SPEED) (S/N A3PG11001 - A3PG12799 AND S/N A3PH11001 - A3PH12325) (CONT'D)**

**Disassembly And Assembly (Cont'd)**

**Figure 30-21-9**

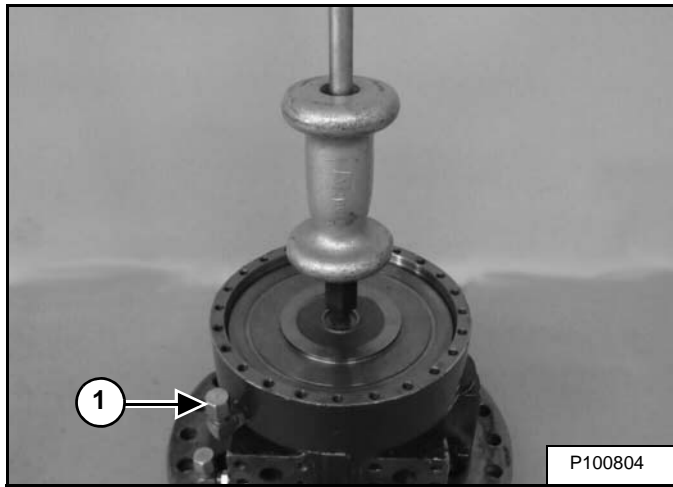

Remove the piston from the brake housing [Figure 30-21-9].

**NOTE:** The use of air pressure through the brake line connection (Item 1) [Figure 30-21-9] will aid in piston removal.

**Figure 30-21-10**

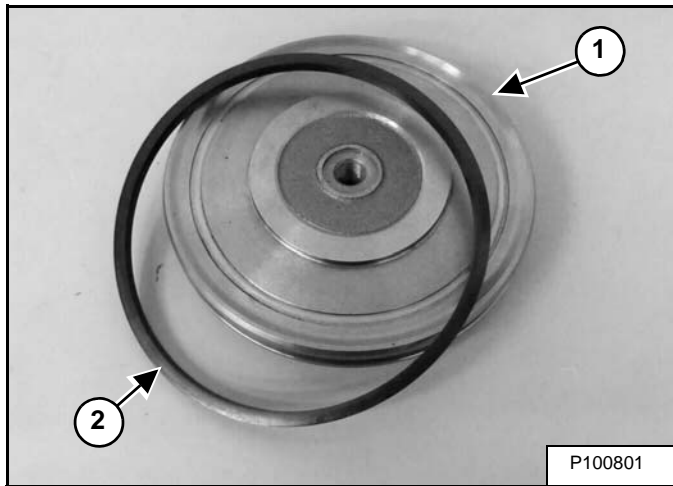

Inspect the brake piston (Item 1) [Figure 30-21-10] for damage including the surface that contacts the brake shaft.

Replace the seal (Item 2) [Figure 30-21-10].

**Assembly:** Apply oil to the seal (Item 2) [Figure 30-21-10] for added protection when installing the brake piston.

**Figure 30-21-11**

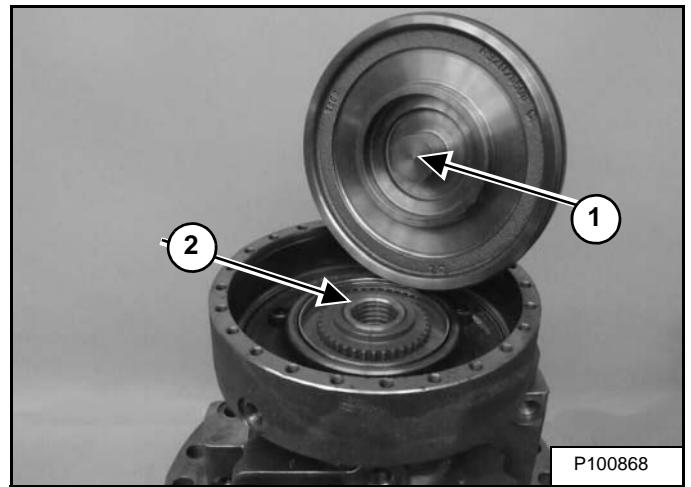

Inspect the piston surface (Item 1) and the bushing surface (Item 2) [Figure 30-21-11] in the brake shaft.

**NOTE:** The bushing (Item 2) [Figure 30-21-11] can be replaced in the brake shaft. When the bushing is replaced, install the bushing flush with the top of the brake shaft.

## HYDROSTATIC DRIVE MOTOR (TWO-SPEED) (S/N A3PG12800 & ABOVE AND S/N A3PH12326 & ABOVE)

### Description

The hydrostatic drive motors are driven by the hydrostatic pump. Machines equipped with SJC / SCPA are monitored by a sensor mounted onto the hydrostatic pump. The sensor is used for detection of motion and for rate of speed for the SJC / SCPA options.

The hydrostatic drive motors contain a spring applied pressure release braking system. In addition there is a separate oil chamber in the motor that is filled with high performance synthetic oil for maximum durability, this oil has a recommended service interval. (See SERVICE SCHEDULE on Page 10-70-1.)

There are two hydrostatic drive motors and they are located on the track carriage.

### Removing And Replacing Oil

For the correct service interval (See SERVICE SCHEDULE on Page 10-70-1.)

Park the loader so that the plug in the hydrostatic drive motor is at the bottom.

Remove the plug and let the oil drain from the hydrostatic drive motor.

**Figure 30-22-1**

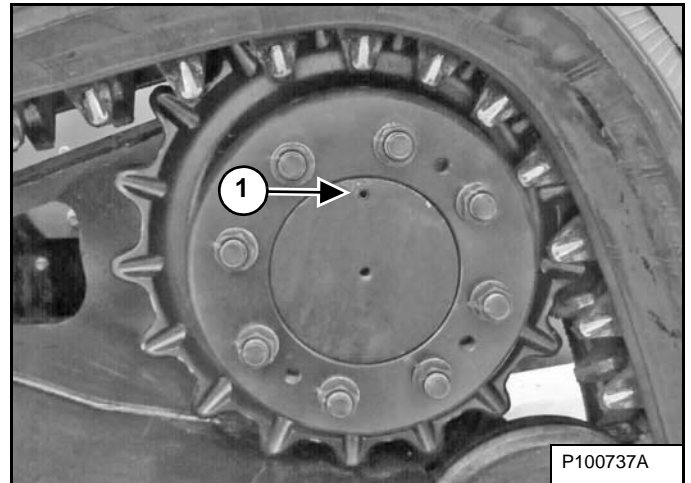

Rotate the hydrostatic drive motor so that the plug (Item 1) [Figure 30-22-1] is at the top. Add high performance synthetic oil (P/N 7024981). (See Capacities on Page SPEC-10-4.)

Clean the threads of the plug and drain hole. Apply Loctite® 243 to the plug threads. Install and tighten the plug.

Repeat for the other hydrostatic drive motor.

Recycle or dispose of the used oil in an environmentally safe manner.

**HYDROSTATIC MOTOR (TWO-SPEED) (S/N A3PG12800 & ABOVE AND S/N A3PH12326 & ABOVE) (CONT'D)**

**Disassembly And Assembly (Cont'd)**

**Figure 30-22-29**

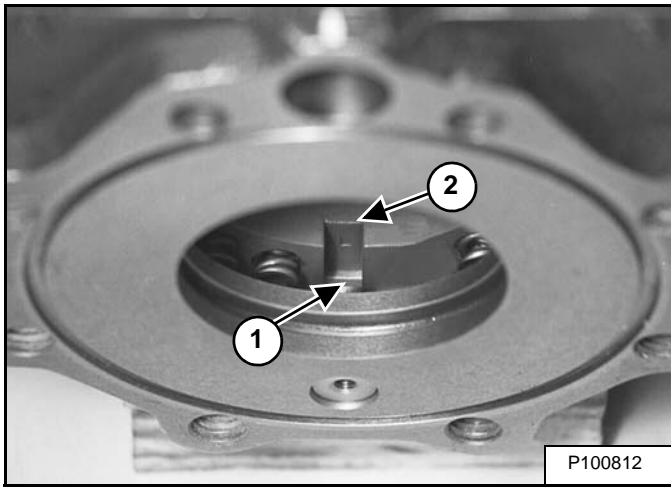

**Assembly:** When installing the distributor align the stop pin (Item 1) with the notch in the distributor (Item 2) [Figure 30-22-29].

When the distributor is aligned correctly, the distributor can be depressed slightly by hand and will return to its original position.

**Figure 30-22-30**

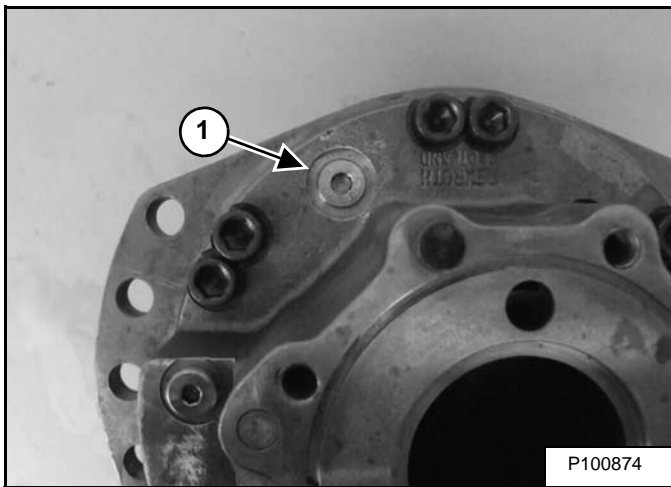

Remove the drain plug (Item 1) [Figure 30-22-30].

**Figure 30-22-31**

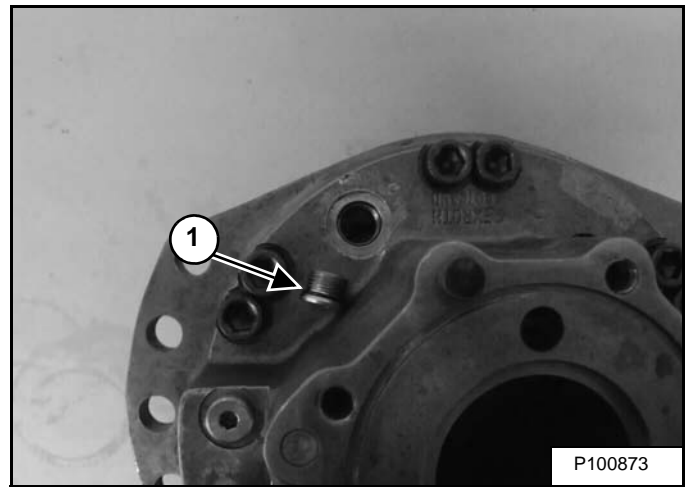

Replace the O-ring (Item 1) [Figure 30-22-31] on the plug. Torque to 60 N•m (44 ft-lb)

**Figure 30-22-32**

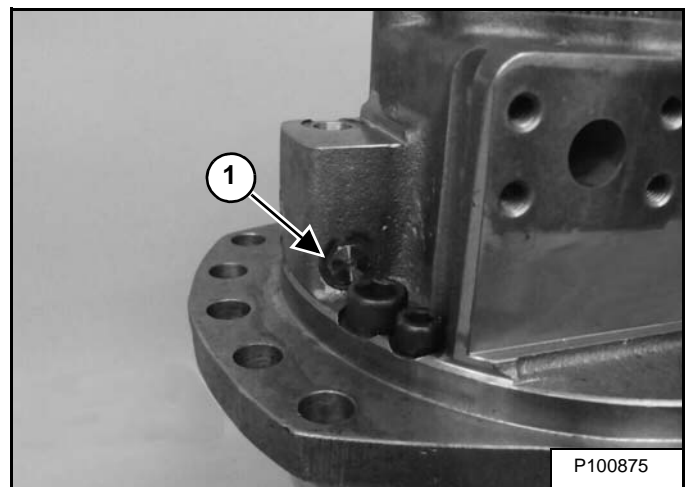

Remove the plug (Item 1) [Figure 30-22-32].

## CHARGE PRESSURE (LATER MODELS) (CONT'D)

### Sender Removal And Installation

Remove the fan duct. (See Lower Fan Duct Removal And Installation on Page 70-50-4.)

Figure 30-31-5

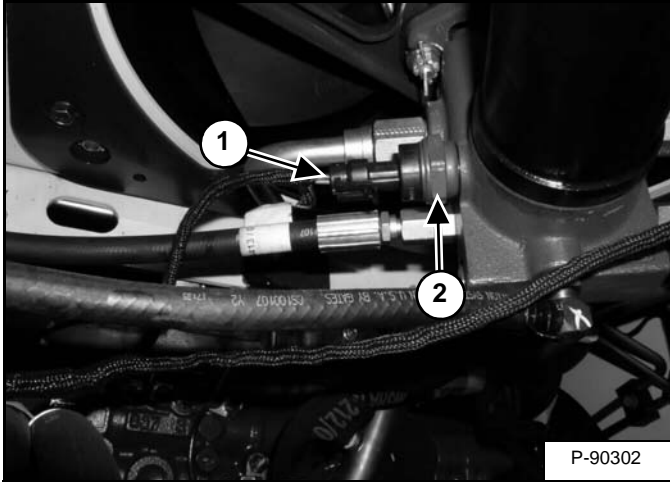

Disconnect the wire (Item 1) [Figure 30-31-5] from the sender.

Remove the sender (Item 2) [Figure 30-31-5] from the motor.

**Installation:** Tighten the charge pressure sender to 10 - 10,9 N•m (7.4 - 8.1 ft-lb) torque.

**NOTE:** Replace the O-ring on the sender before installation.

## HYDROSTATIC PUMP (SJC AND SCAPA) (CONT'D)

### Disassembly (Cont'd)

Figure 30-40-24

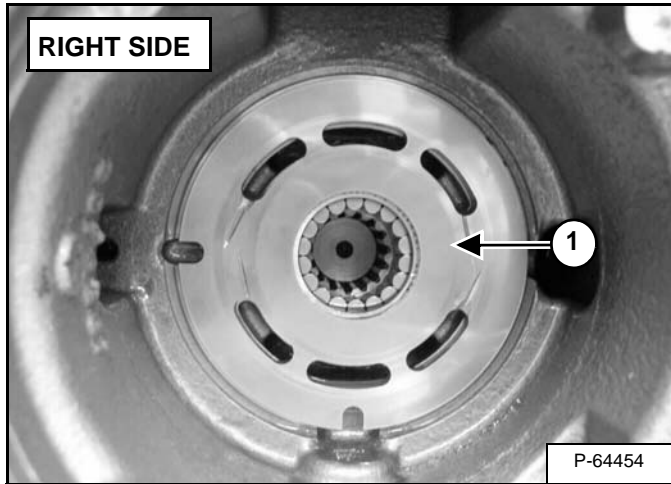

Remove valve plate (Item 1) [Figure 30-40-24] from the right side pump.

**NOTE: The valve plates are NOT interchangeable between the right and left sides.**

Figure 30-40-25

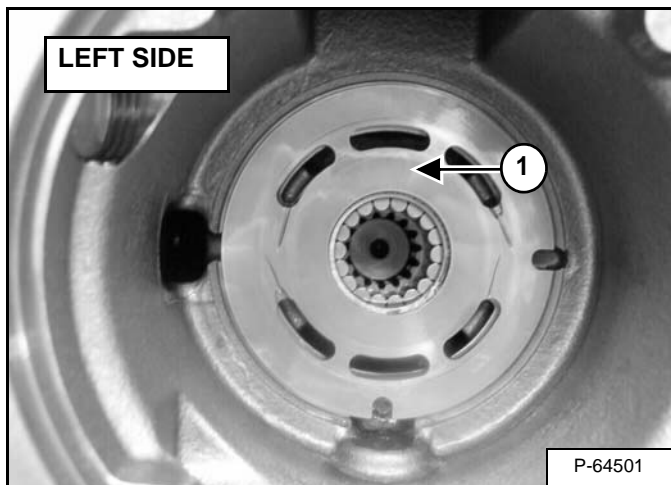

Remove valve plate (Item 1) [Figure 30-40-25] from the left side pump.

**NOTE: The valve plates are NOT interchangeable between the right and left sides.**

Figure 30-40-26

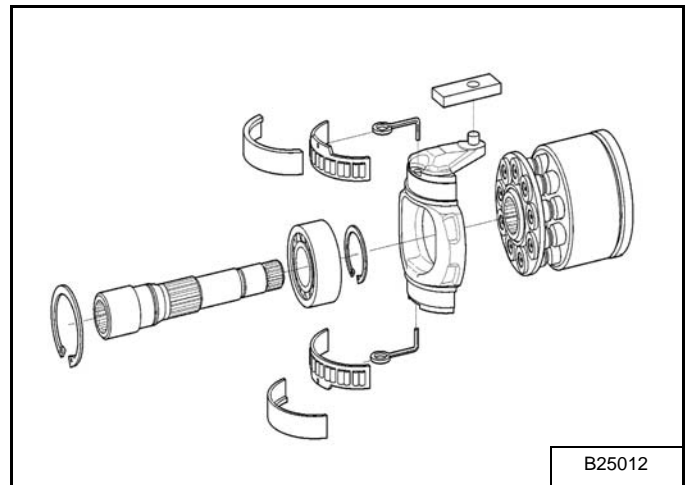

Disassemble the right side rotating group [Figure 30-40-26].

Figure 30-40-27

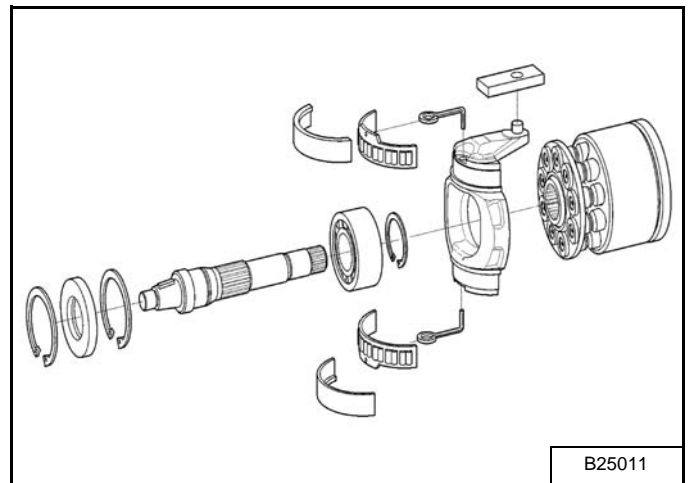

Disassemble the left side rotating group [Figure 30-40-27].

## HYDROSTATIC PUMP (SJC AND SCAPA) (CONT'D)

### Assembly (Cont'd)

Figure 30-40-70

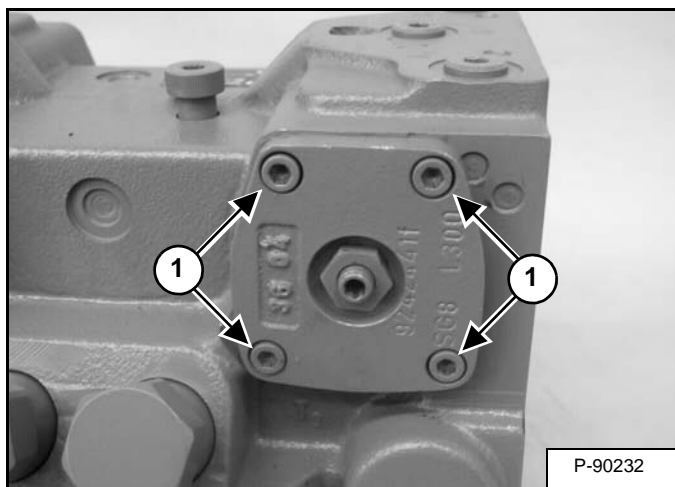

Install the bolts (Item 1) [Figure 30-40-70].

Tighten the bolts to 10,4 N•m (7.7 ft-lb) torque.

## HYDROSTATIC PUMP (SJC AND SCAPA) (CONT'D)

### Hydraulic Controller Neutral Adjustment (Cont'd)

Figure 30-40-107

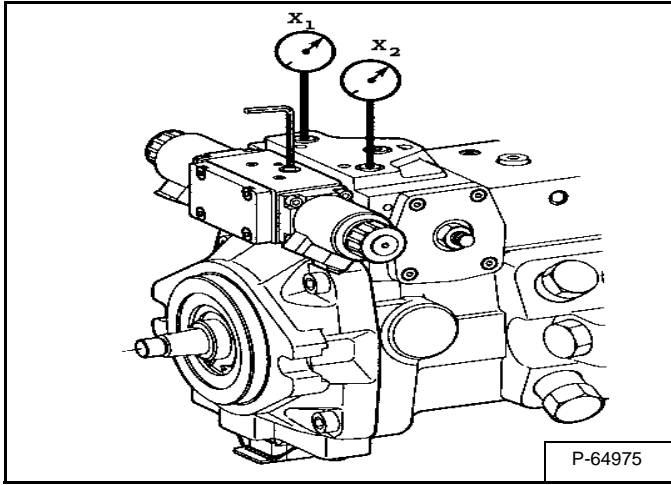

Install 3447 kPa (34 bar) (500 psi) pressure gauges in the X1 and X2 ports [Figure 30-40-107].

Figure 30-40-108

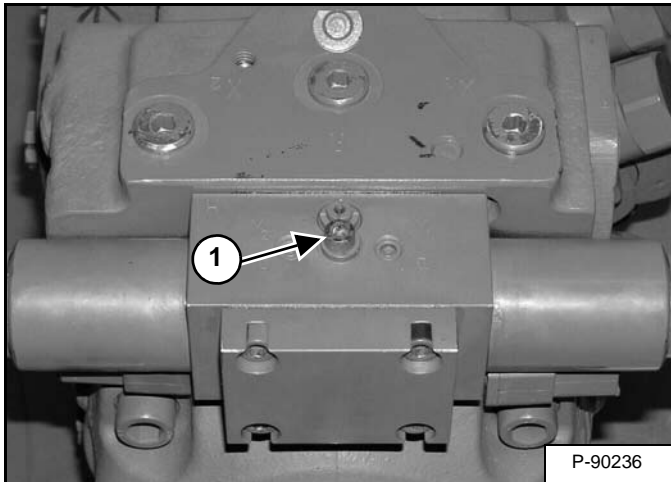

Loosen the screw (Item 1) [Figure 30-40-108].

Start the loader using the Remote Start Tool and run at an idle.

## WARNING

Stay clear of the loader wheels. They will turn whenever the pump is not centered.

W-2276-1297

Figure 30-40-109

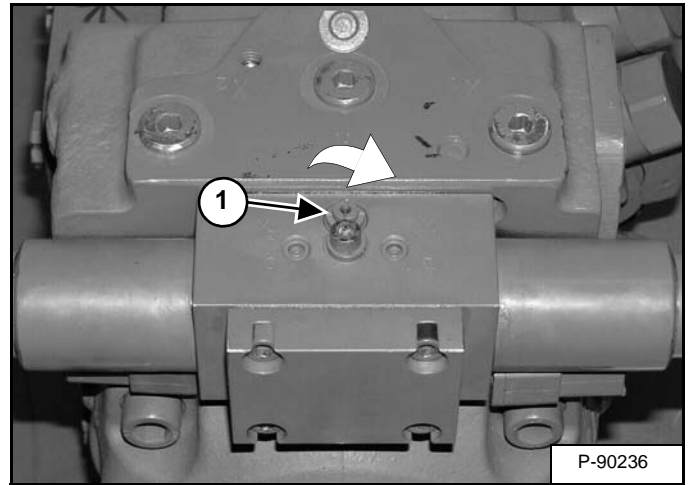

Turn the adjustment screw (Item 1) [Figure 30-40-109] clockwise, until one of the gauges registers an increase in system pressure. Mark the position of the adjustment screw.

Figure 30-40-110

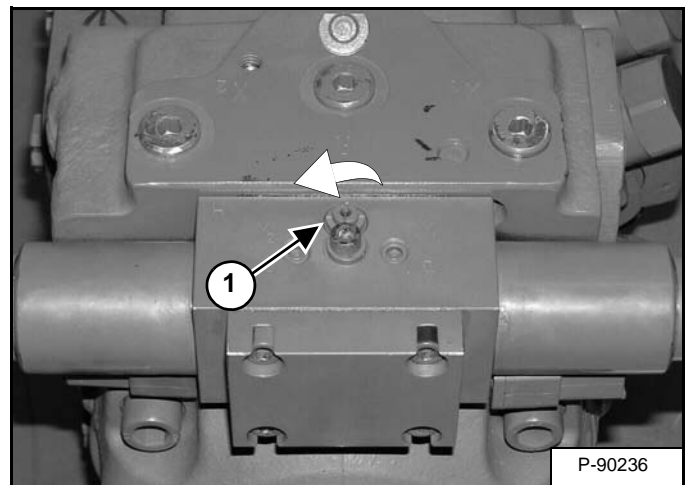

Turn the adjustment screw (Item 1) [Figure 30-40-110] counterclockwise, until the other gauge registers an increase in system pressure. Mark the position of the adjustment screw.

**TWO-SPEED / BRAKE VALVE (S/N A3PG11001 - A3PG12799 AND S/N A3PH11001 - A3PH12325) (CONT'D)**

**Valve Block Disassembly And Assembly (Cont'd)**

**Figure 30-60-10**

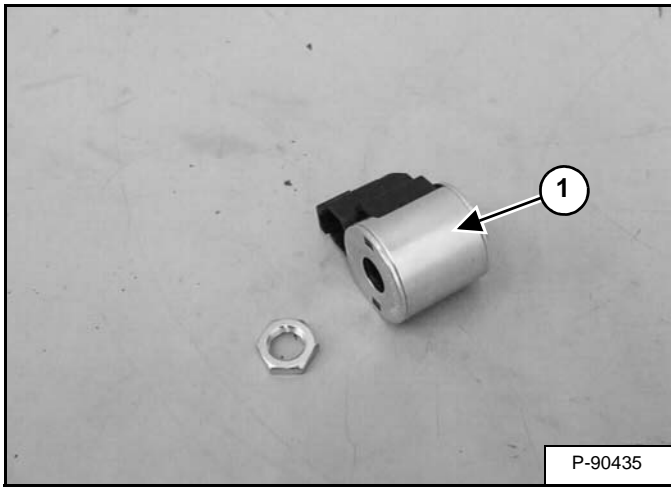

Use a test meter and test the solenoid coils (Item 1) [Figure 30-60-10] for resistance.

The resistance value for the solenoid coil can be found on the electrical schematic.

**Figure 30-60-11**

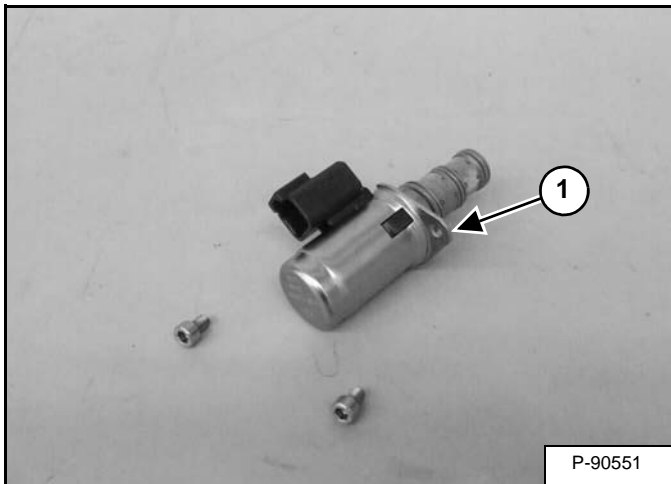

Use a test meter and test the solenoid coils (Item 1) [Figure 30-60-11] for resistance.

The resistance value for the solenoid coil can be found on the electrical schematic.

**Figure 30-60-12**

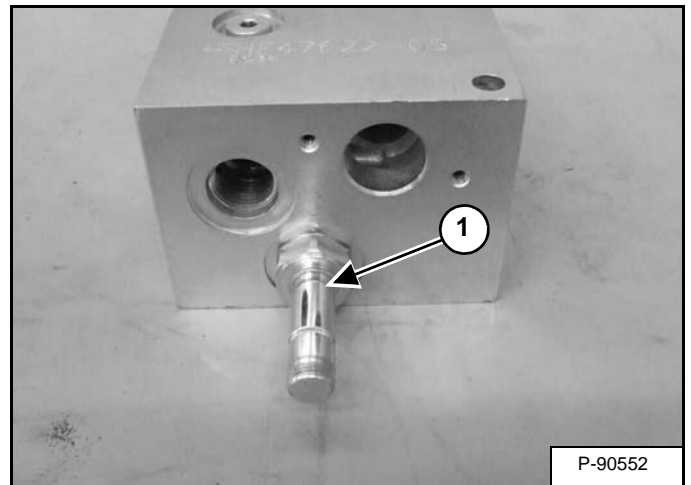

Remove the make-up solenoid (Item 1) [Figure 30-60-12] from the valve block.

**Assembly:** Tighten the solenoid valve to 27,1 N•m (20 ft-lb) torque.

**Figure 30-60-13**

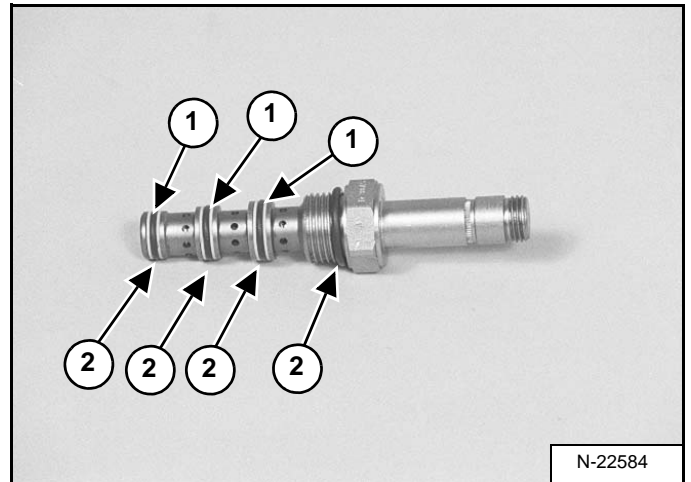

Remove the back-up rings (Item 1) and O-rings (Item 2) [Figure 30-60-13].

## BRAKE

### Description

Figure 40-10-1

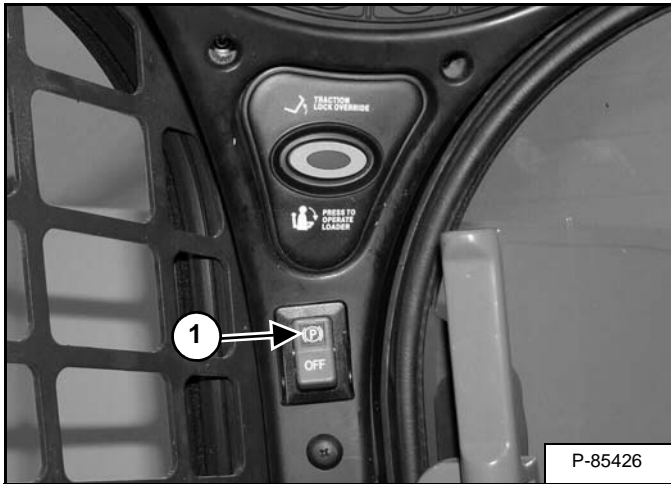

The brake is used to hold the machine in place. The brake is operated by a switch (Item 1) [Figure 40-10-1] located on the left panel.

## Block Removal And Installation

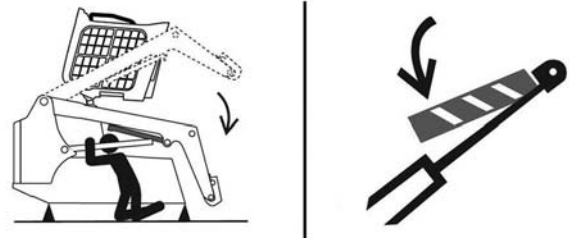

P-90328

### AVOID DEATH

- Disconnecting or loosening any hydraulic tubeline, hose, fitting, component or a part failure can cause lift arms to drop.
- Keep out of this area when lift arms are raised unless supported by an approved lift arm support. Replace if damaged.

D-1009-0409



Never work on a machine with the lift arms up unless the lift arms are secured by an approved lift arm support device. Failure to use an approved lift arm support device can allow the lift arms or attachment to fall and cause injury or death.

W-2059-0598

Raise the lift arms and install an approved lift arm support device. (See Installing on Page 10-20-1.)

Raise the operator cab. (See Raising on Page 10-30-2.)

## TRACK UNDERCARRIAGE COMPONENTS (ROLLER SUSPENSION) (CONT'D)

### Idler (Front) Removal And Installation

Remove the track. (See Track Removal And Installation on Page 40-20-7.)

Figure 40-20-15

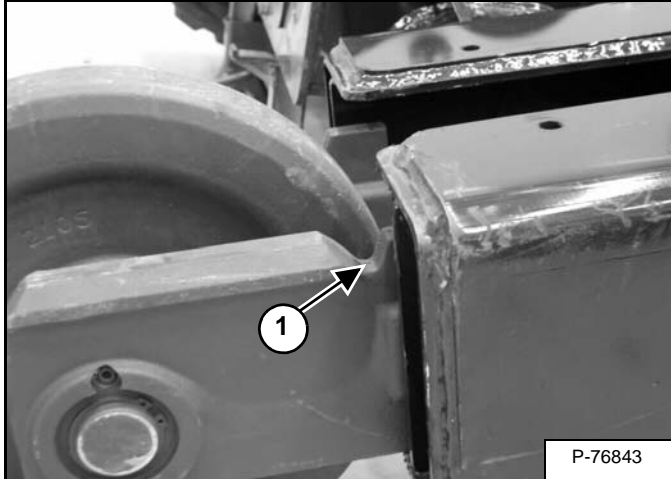

Slide the front idler wheel out of the track housing [Figure 40-20-15].

**NOTE:** The notch on the front idler wheel frame (Item 1) [Figure 40-20-15] is toward the top of the track housing for installation.

Figure 40-20-16

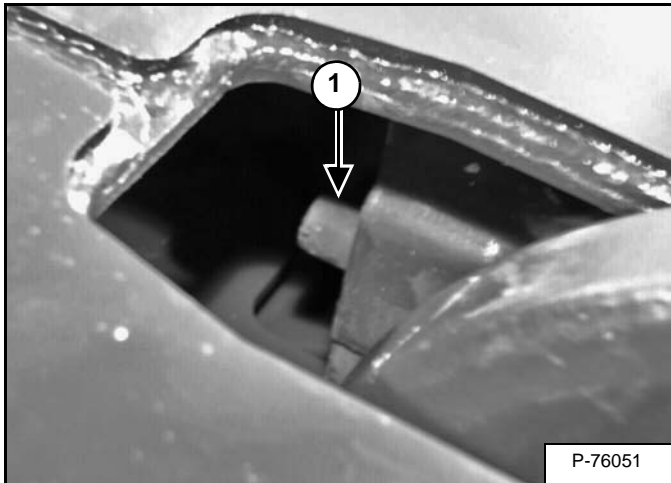

**Installation:** Make sure the pins (Item 1) [Figure 40-20-16] on the front idler wheel frame engage the holes in the track tensioner.

Figure 40-20-17

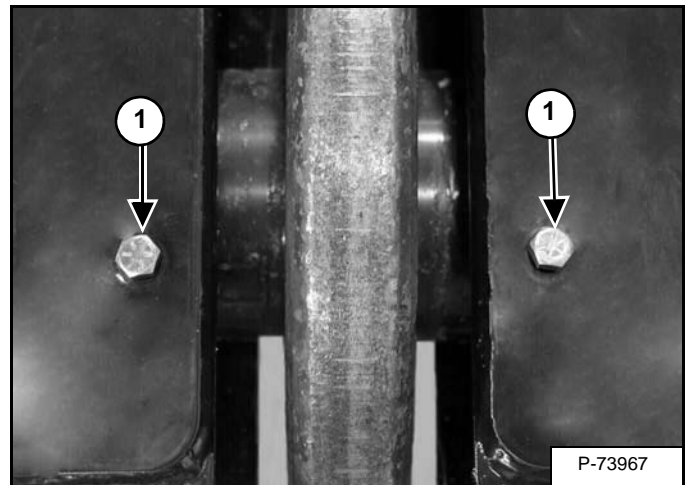

**Installation:** Two short 9,5 mm (3/8 in) bolts (Item 1) [Figure 40-20-17] may be inserted to keep the front idler wheel in place until the track is installed.

**NOTE:** The bolts must be removed before completing track installation. It will not be possible to remove the bolts after track tension has been set.

Figure 40-20-18

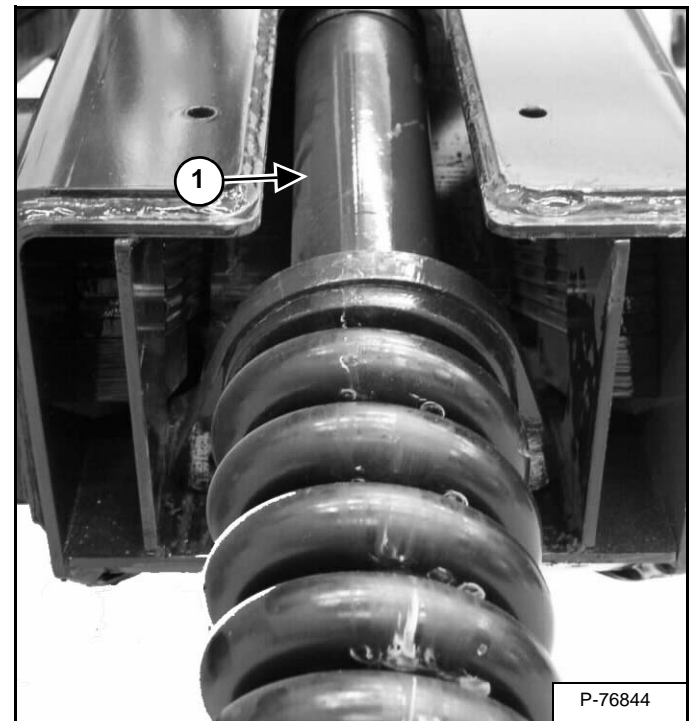

Slide the track tensioner (Item 1) [Figure 40-20-18] out of the track housing.

**Installation:** Track tensioner must be oriented as shown in [Figure 40-20-18] before sliding it into the track housing.

## TRACK MAINTENANCE (CONT'D)

### Track Damage Identification (Cont'd)

#### Separation Of Embedded Metals

Figure 40-30-7



#### Damage:

Extraordinary outer forces applied to embedded metals cause their separation from the rubber track's body [Figure 40-30-7].

#### Replacement:

Even a partial separation of embedded metals requires replacement of the track.

Figure 40-30-8

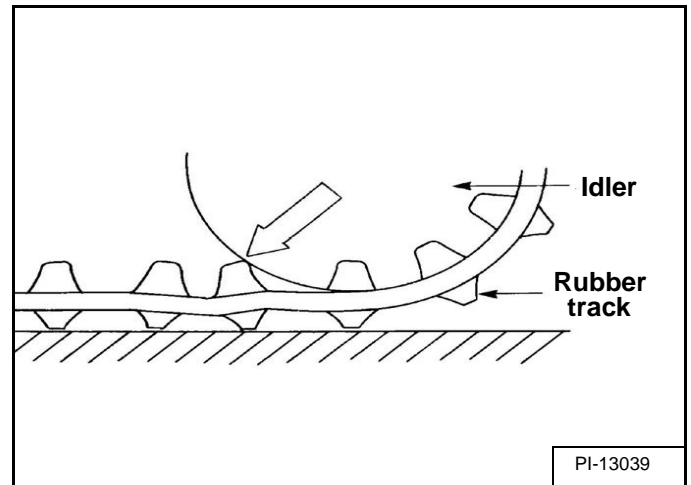

#### Causes of the damage:

Embedded metals are adhered between the steel cords and the rubber body. The following cases generate external forces greater than the adhesion strength, causing separation of the embedded metals:

When the idler continually rides on the projections of embedded metals, the embedded metals will eventually peel off [Figure 40-30-8].

Figure 40-30-9

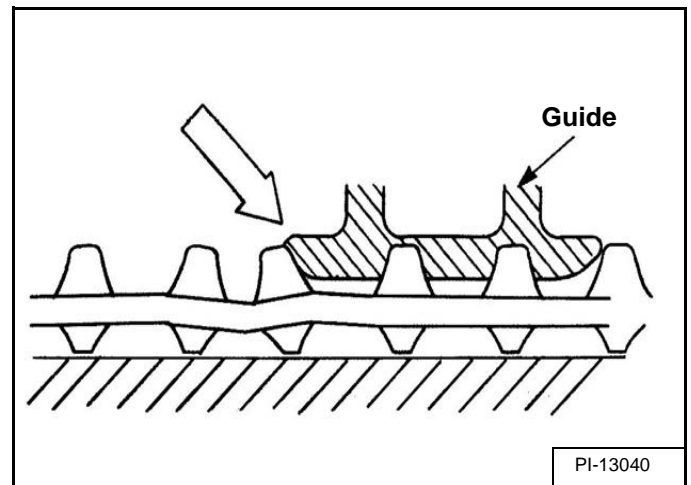

When a rubber track is detracked, it becomes stuck between the guide or the undercarriage frame, causing the separation of embedded metals [Figure 40-30-9].

WINDOW (REAR) .....	50-130-1
Rear Window Identification .....	50-130-1
Removal (Rubber Cord) .....	50-130-1
Installation (Rubber Cord) .....	50-130-2
Removal And Installation (Latches) .....	50-130-4
Disassembly And Assembly (Latches) .....	50-130-4
WINDOW (TOP) .....	50-131-1
Removal And Installation .....	50-131-1
WINDOW (SIDE) .....	50-132-1
Removal And Installation .....	50-132-1
CAB DOOR .....	50-140-1
Description .....	50-140-1
Removal And Installation .....	50-140-1
Disassembly And Assembly .....	50-140-2
Aligning .....	50-140-3
Adjusting .....	50-140-4
Checking Operation .....	50-140-4
ARMREST .....	50-150-1
Description .....	50-150-1
Removal And Installation .....	50-150-2
Disassembly And Assembly .....	50-150-3
LEFT SIDE LOWER PANEL .....	50-160-1
Removal And Installation .....	50-160-1
Disassembly And Assembly .....	50-160-3
RIGHT SIDE LOWER PANEL .....	50-170-1
Removal And Installation .....	50-170-1
Disassembly And Assembly .....	50-170-2
HEADLINER .....	50-180-1
Removal And Installation .....	50-180-1

## OPERATOR SEAT (SUSPENSION) (CONT'D)

### Lower Cushion Installation

Figure 50-30-7

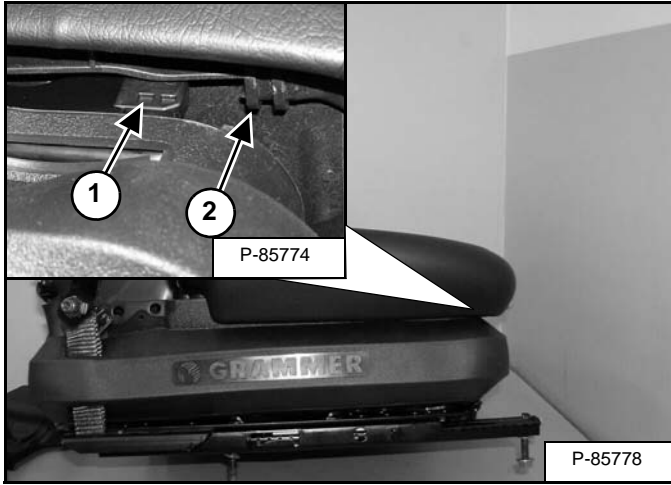

Insert the tab (Item 1) into the slot (Item 2) [Figure 50-30-7].

Figure 50-30-8

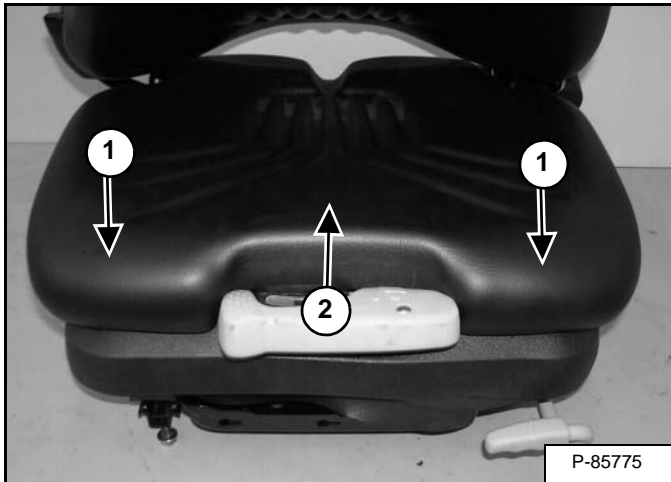

Push down on the front of the seat (Item 1) and push back (Item 2) [Figure 50-30-8] to lock the seat into position.

### Back Cushion Removal And Installation

Figure 50-30-9

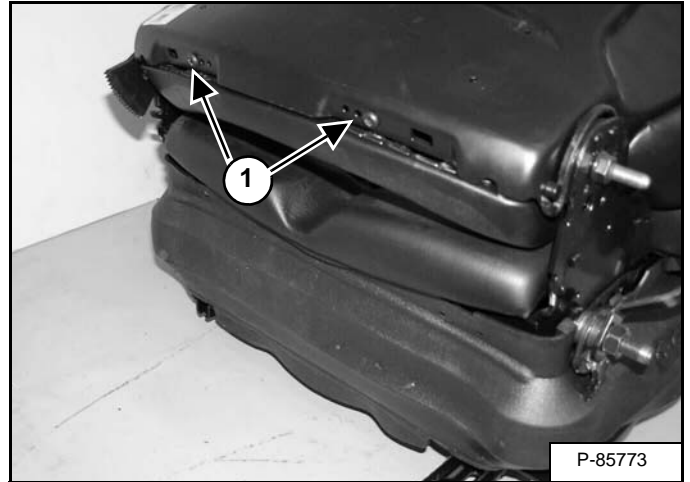

Tilt the seat all the way forward.

Remove the two screws (Item 1) [Figure 50-30-9] and tilt the seat back to the upright position.

Remove the back cushion from the seat

## BOB-TACH (POWER) (CONT'D)

### Removal And Installation (Cont'd)

Figure 50-41-6

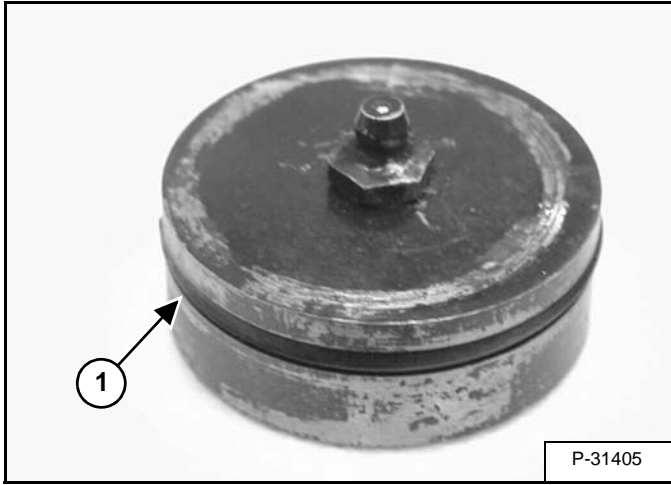

Check and replace the O-ring (Item 1) [Figure 50-41-6] on the grease plug.

Figure 50-41-7

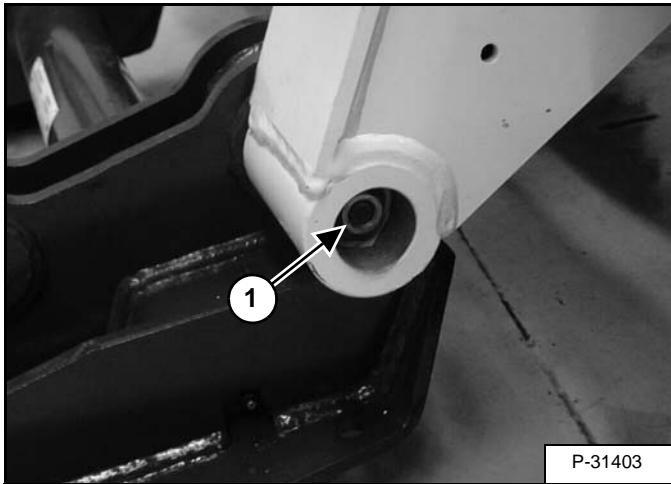

Remove the nut (Item 1) [Figure 50-41-7] from the Bob-Tach pivot pin retaining bolt (both sides).

Figure 50-41-8

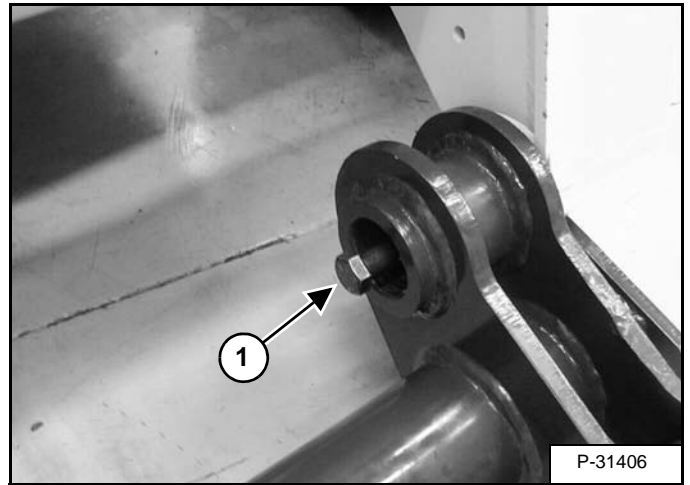

Remove the retainer bolt (Item 1) [Figure 50-41-8] from the Bob-Tach pivot pin (both sides).

**Installation:** Tighten the retainer nut and bolt (Item 1) [Figure 50-41-7] and [Figure 50-41-8] to 446 N•m (330 ft-lb) torque.

Figure 50-41-9

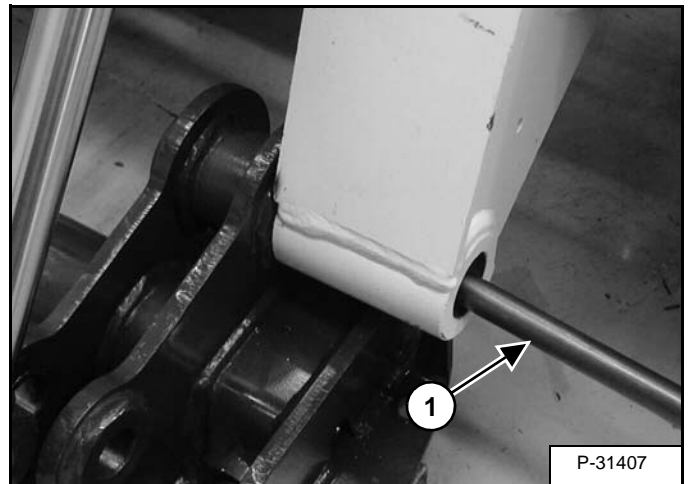

With a 22,2 mm (0.875 in) punch (Item 1) [Figure 50-41-9] and a hammer, drive the pivot pin out of the lift arm and Bob-Tach (both sides).

Remove the Bob-Tach from the loader.

**NOTE:** MEL1685 - Pivot Point Tapered Reamer is available to ream out tapered bore if necessary.

## REAR DOOR (TAILGATE)

### Removal And Installation

Figure 50-70-1

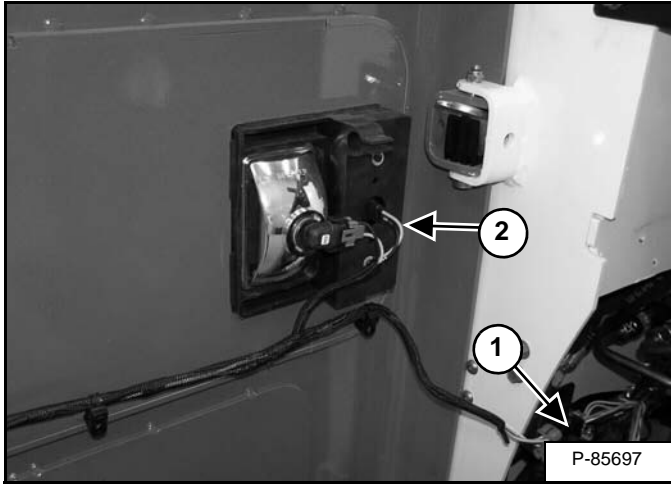

Disconnect the light harness connector (Item 1) [Figure 50-70-1] from the main frame harness.

Remove both rear lights (Item 2) [Figure 50-70-1] from the door. (See Rear Removal And Installation on Page 60-60-2.)

Figure 50-70-2

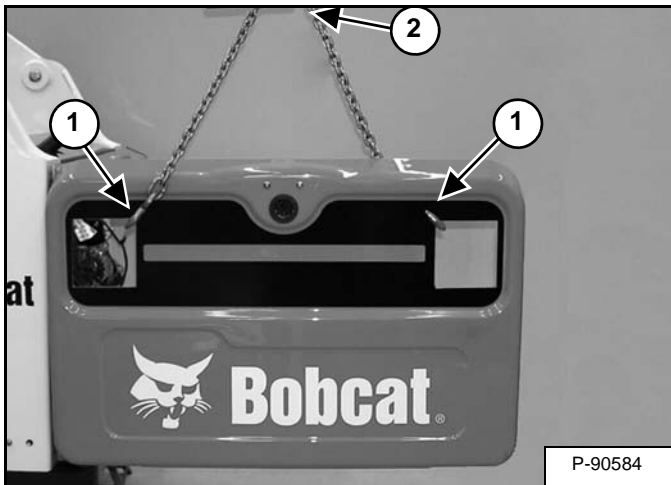

Secure the chain hooks (Item 1) [Figure 50-70-2] to the door as shown.

Connect a chain hoist (Item 2) [Figure 50-70-2] to the lifting chain.

Figure 50-70-3

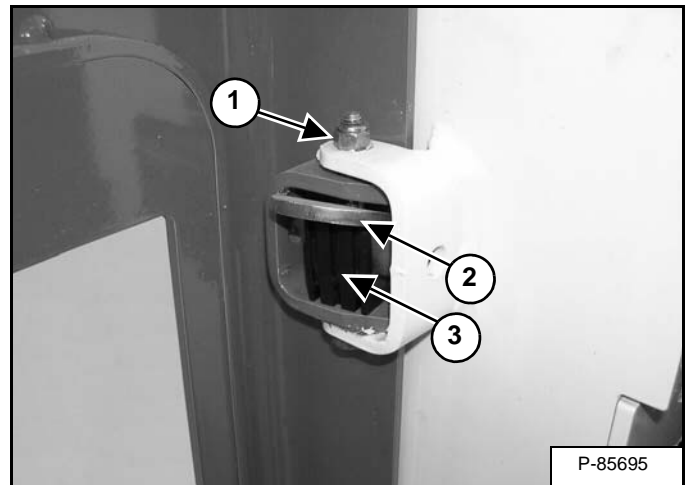

Remove the top and bottom door hinge mounting bolts and nuts (Item 1) [Figure 50-70-3].

**NOTE:** Install the door stop (Item 2) and the door stop retainer (Item 3) in the top hinge as shown [Figure 50-70-3].

**Installation:** Tighten the mounting bolts and nuts to 34 - 38 N•m (25 - 28 ft-lb) torque.

Lift the door away from the loader frame and put the door flat on the floor.

CLICK HERE TO **DOWNLOAD** THE COMPLETE MANUAL

- Thank you very much for reading the preview of the manual.
- You can download the complete manual from: [www.heydownloads.com](http://www.heydownloads.com) by clicking the link below



- Please note: If there is no response to CLICKING the link, please download this PDF first and then click on it.

CLICK HERE TO **DOWNLOAD** THE COMPLETE MANUAL

## CONTROL PEDALS AND LINKAGES (SCPA) (CONT'D)

### Linkage Removal And Installation (Cont'd)

Figure 50-90-7

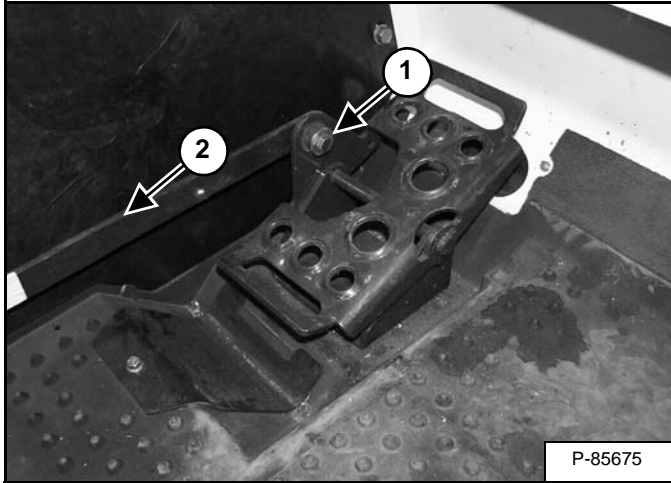

Remove the bolt (Item 1) [Figure 50-90-7] and nut from the pedal linkage.

Remove the linkage (Item 2) [Figure 50-90-7].

Figure 50-90-8

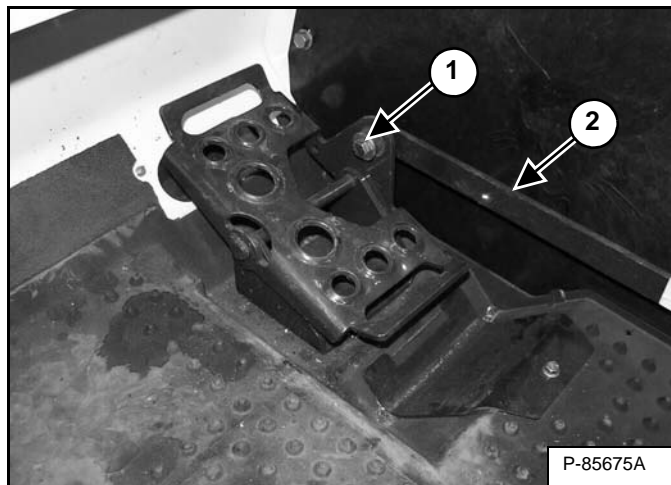

Remove the bolt (Item 1) [Figure 50-90-8] and nut from the pedal linkage.

Remove the linkage (Item 2) [Figure 50-90-8].

### Pedal (Adjusting)

After installing the pedal, adjust the pedal angle so that there is clearance under the rear of the pedal. The valve spool must travel full stroke without the pedal hitting the floor panel.

The pedals should be positioned at a comfortable angle so full movement of the pedal can be reached easily while properly sitting in the loader seat.

Figure 50-90-9

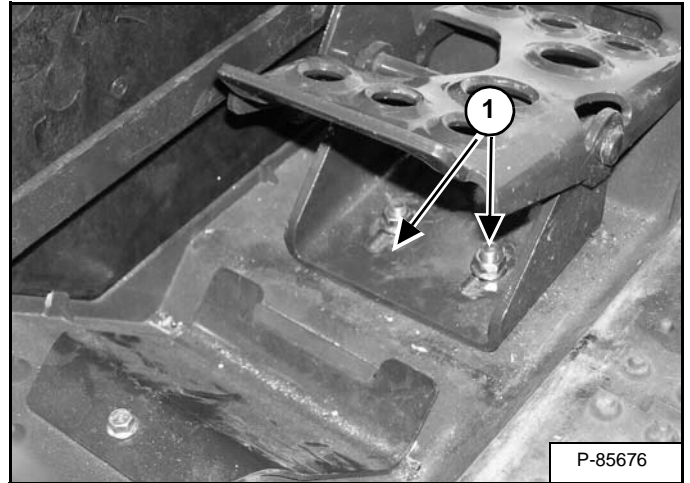

Loosen the two mounting bolts (Item 1) [Figure 50-90-9] from the pedal mounting bracket.

Figure 50-90-10

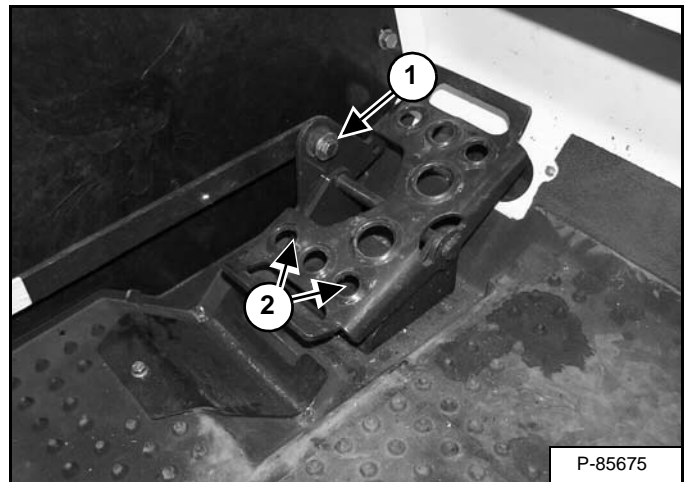

Loosen the bolt (Item 1) [Figure 50-90-10] and nut on the pedal linkage.

Check the bushing in the pedal for wear and replace as needed.

Tilt the pedal back and forth until an acceptable "neutral" angle is achieved on the pedal.

Tighten the two nuts (Item 2) and pivot bolt (Item 1) [Figure 50-90-10] on the pedal assembly to standard torque.

## ACCESS PANEL (INSIDE) (SJC)

### Removal And Installation (Left)

Figure 50-121-1

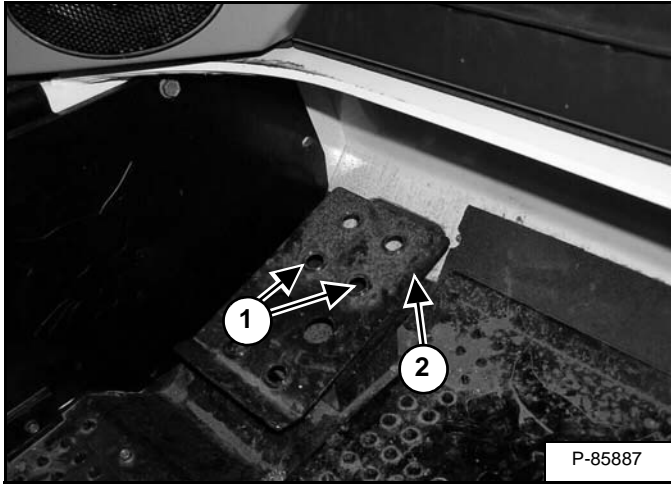

Remove the two mounting nuts (Item 1) and remove the foot rest (Item 2) [Figure 50-121-1].

Figure 50-121-2

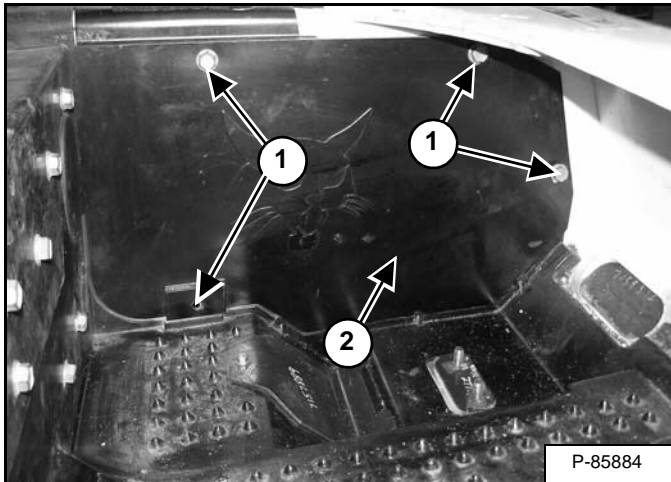

Remove the mounting bolts (Item 1) and remove the inside left access panel (Item 2) [Figure 50-121-2].

### Removal And Installation (Right)

Figure 50-121-3

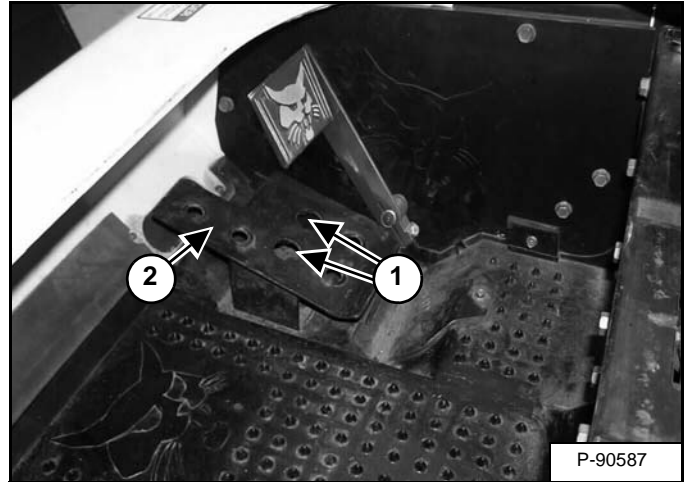

Remove the two mounting nuts (Item 1) and remove the foot rest (Item 2) [Figure 50-121-3].

Figure 50-121-4

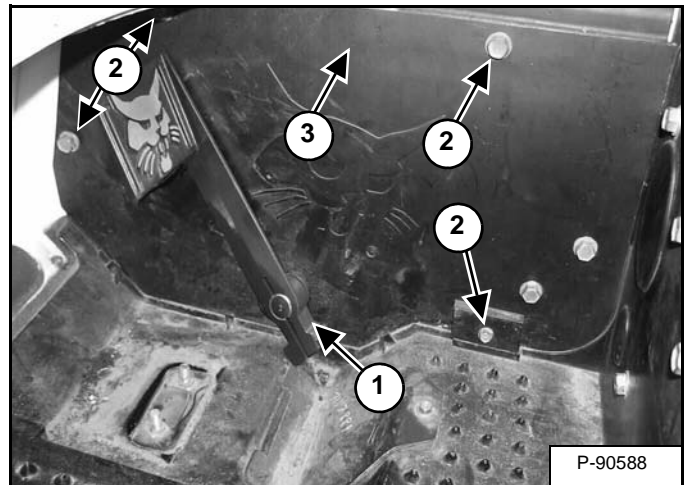

Remove the bolt and engine speed control pedal (Item 1) and remove the mounting bolts (Item 2) [Figure 50-121-4].

Remove the right inside access panel (Item 3) [Figure 50-121-4].

## CAB DOOR (CONT'D)

### Disassembly And Assembly (Cont'd)

Figure 50-140-9

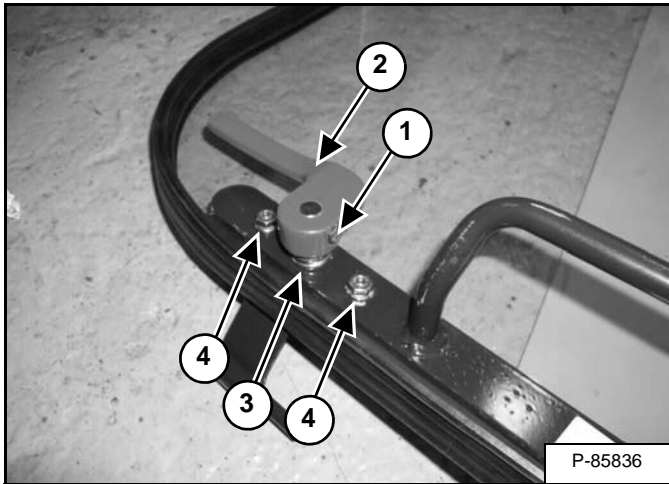

Remove the bolt (Item 1), the latch (Item 2), and spring (Item 3) [Figure 50-140-9].

Remove the two nuts and bolts (Item 4) [Figure 50-140-9].

**Installation:** Tighten the nuts (Item 4) to 31 - 34 N•m (270 - 300 in-lb) torque.

Figure 50-140-10

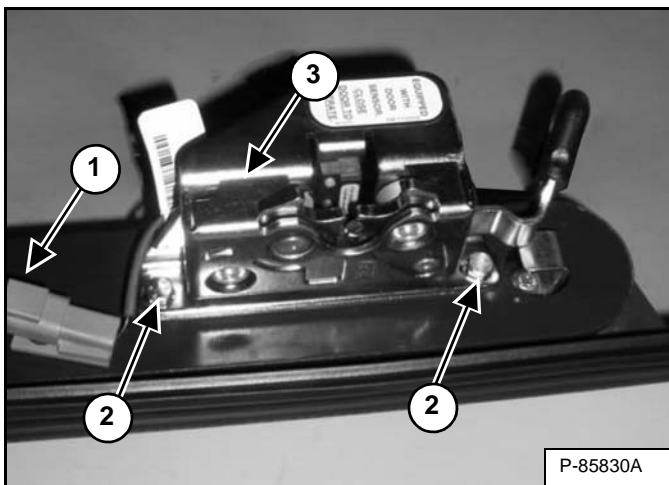

Disconnect the harness (Item 1) [Figure 50-140-10].

Remove the two bolts (Item 2), and the latch assembly (Item 3) from the cab door [Figure 50-140-10].

Remove the glass from the frame.

## Aligning

Figure 50-140-11

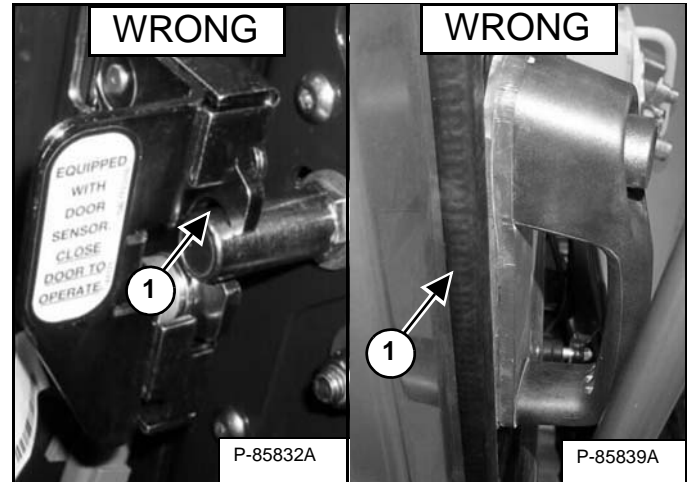
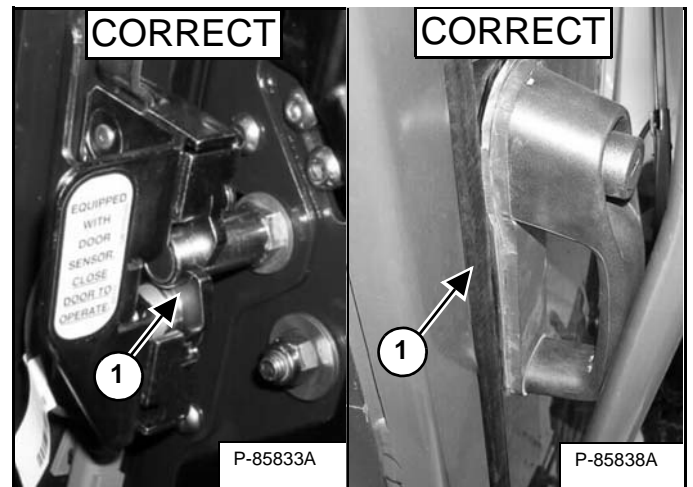

Figure 50-140-12



When the striker or latch is NOT adjusted properly there will be a gap (Item 1) [Figure 50-140-11] between the door and the cab or the striker and the latch.

If adjustment is needed. (See Adjusting on Page 50-140-4.)

When the striker or latch is adjusted properly there will be no gap (Item 1) [Figure 50-140-12] between the door and the cab or the striker and the latch.

After verifying alignment check for proper operation. (See Checking Operation on Page 50-140-4.)

## RIGHT SIDE LOWER PANEL

### Removal And Installation

Raise the operator cab. (See Raising on Page 10-30-2.)

**Figure 50-170-1**

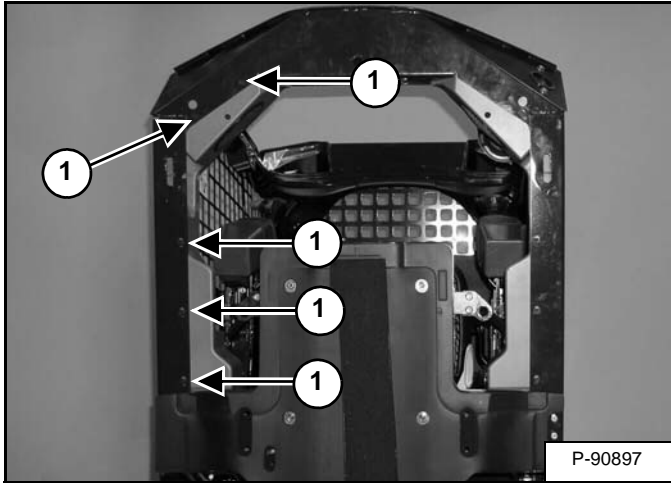

Remove the five plastic rivets (Item 1) [Figure 50-170-1].

Remove the seat. (See Removal And Installation on Page 50-30-1.)

Lower the operator cab. (See Lowering on Page 10-30-3.)

**NOTE:** With the seat removed, the cab may raise.

**Figure 50-170-2**

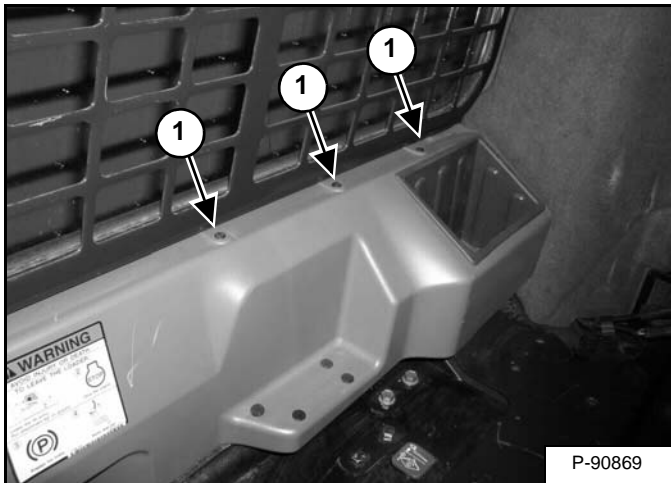

Remove the three plastic screws and the anchors (Item 1) [Figure 50-170-2] from the right side lower panel.

**Figure 50-170-3**

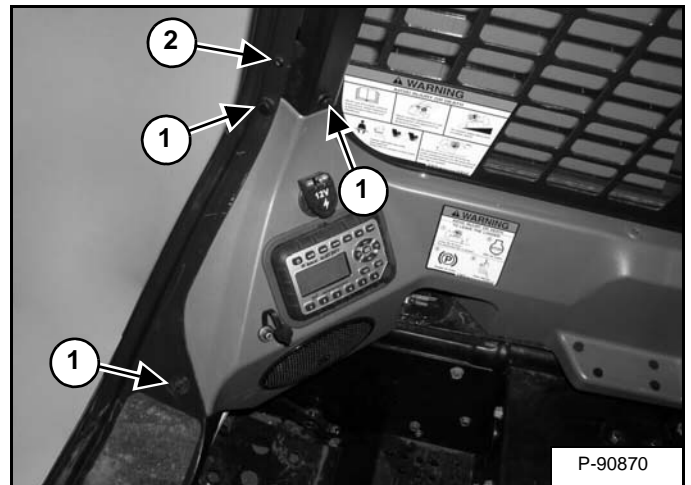

Remove the three plastic rivets and anchors (Item 1) and the screw (Item 2) [Figure 50-170-3].

**Figure 50-170-4**

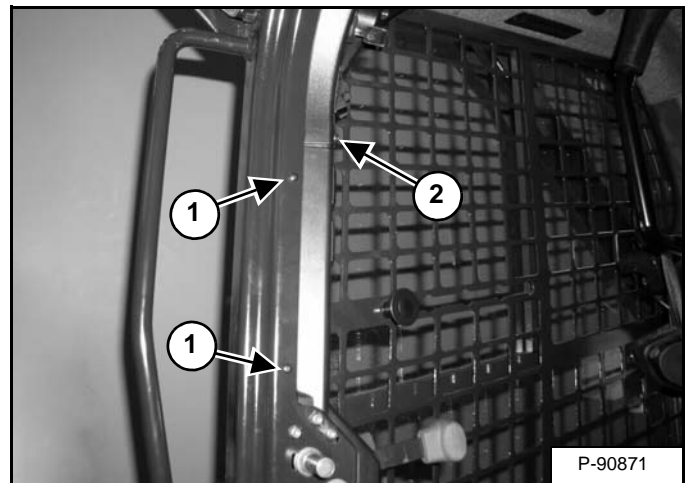

Remove the two screws (Item 1) and the plastic rivet (Item 2) [Figure 50-170-4].

CONNECTOR ASSIGNMENTS											
CONN	DESCRIPTION	NUM OF PINS	SHEET	CONN	DESCRIPTION	NUM OF PINS	SHEET	CONN	DESCRIPTION	NUM OF PINS	SHEET
C101	FUEL SHUTOFF SOLENOID	3	6	C446	HYDRAULIC FAN	2	7	FC1	FUSE CENTER 1	8	3
C103	TAILGATE	8	4,10,11,13	C449	LEFT JOYSTICK (CAB HARN)	4	5,10	FC2	FUSE CENTER 2	8	3
C104	ENGINE COOLANT SENSOR	2	6	C450	RIGHT JOYSTICK (CAB HARN)	4	5,10	FRC1	FUSE RELAY CENTER	64	3,6,7,11,12
C105	HYD CHARGE PRESSURE	3	7	C453	RIGHT SPEED SENSOR	4	10				
C106	ENGINE SPEED SENSOR	2	6	C454	LEFT SPEED SENSOR	4	10	J1A	GATEWAY CONTROLLER	34	
C107	ENGINE OIL PRESSURE	3	6	C454-1	MFR SPEED SENSOR	4	10	J1B	GATEWAY CONTROLLER	26	
C108	HYD TEMPERATURE SENDER	2	7	C454-2	SPEED SENSOR	4	10	J2A	AUX CONTROLLER	34	
C109	S/R ADAPTER HARNESS	2	6	C459	LEFT JOYSTICK (SEAT HARN)	4	10	J2B	AUX CONTROLLER	26	
C110	ALTERNATOR	2	6	C460	RIGH JOYSTICK (SEAT HARN)	4	10	J5	DRIVE CONTROLLER	50	
C112	HYD OIL FILTER SWITCH	2	7	C474	BRAKE LIGHT	1	10				
C126	HORN	2	13	C479	LEFT PANEL(BLACK)	12	5,8	SW1	BRAKE SWITCH	6	8
C129	CAB ACCESSORY	3	9	C480	LEFT PANEL(GRAY)	12	8	SW2	BEACON SWITCH	6	13
C209	DOME LIGHT	3	9	C482	SEATBAR SENSOR	3	9	SW3	HAZARD SWITCH	6	13
C212	POWER SOCKET	2	9	C483	TEMP CONTROL SWITCH	3	12	SW4	HAND/FOOT, H/ISO SWITCH	6	10
C250	DOOR SENSOR	2	9	C486	AC COMPRESSOR	2	12	SW5	POWER BOBTACH SWITCH	6	13
C251	WIPER	5	9	C489	MFR ACCESSORY	2	3,4	SW6	BUCKET POSITION SWITCH	6	13
C252	WASHER	2	9	C497	SJC HORN/BLINKER	3	13	SW8	FRONT WIPER SWITCH	6	9
C277	AIR RIDE SEAT	6	13	C499	PTOL	4	8	SW9	TRAVEL CONTROL SWITCH	6	8
C278	RIGHT SPEAKER	2	13	C500	RH KEY SWITCH	6	8	SW10	BLOWER SWITCH	5	12
C279	LEFT SPEAKER	2	13	C501	A22 PUMP HARNESS	8	10	SW11	AC SWITCH	3	12
C308	BRAKE SOLENOID	2	7	C503	RH DLX PANEL	6	5,8				
C350	AC EVAPORATOR SWITCH	2	12	C536	A22 PUMP HARN - L SWASH	4	10	T1	BATT GROUND	1	4
C355	DLX or STD FUEL HARNESS	6	6,12,13	C537	A22 PUMP HARN - R SWASH	4	10	T2	BUZZER GROUND	1	8
C405	AIR FILTER SWITCH	2	6	C542	LEFT SWASHPLATE	3	10	T3	FLASHER	1	13
C406	FUEL SENDER	2	6	C543	RIGHT SWASHPLATE	3	10	T6	BATT GROUND	1	4
C408	CAB - MFR HARN CONNECTOR	48	3-5, 8-13	C544	LEFT FORWARD DRIVE	2	10	T8	BATT GROUND	1	4
C411	LEFT HANDLE 5 WAY (FLSHR)	5	13	C545	LEFT REVERSE DRIVE	2	10	T13	BUZZER POWER	1	8
C412	LEFT HANDLE 2 WAY (HORN)	2	13	C546	RIGHT FORWARD DRIVE	2	10	T14	PRE HEATER	1	6
C415	HIGH FLOW SOLENOID	2	7	C547	RIGHT REVERSE DRIVE	2	10	T15	RIGHT REAR WORK LIGHT(+)	1	11
C418	FRONT ROD	2	7	C602	LEFT REAR TAIL LIGHT	2	11	T16	RIGHT REAR WORK LIGHT(-)	1	11
C419	FRONT BASE	2	7	C603	RIGHT REAR TAIL LIGHT	2	11	T17	LEFT REAR WORK LIGHT (+)	1	11
C420	HYD LOCK	2	7	C606	POWER BOBTACH OPEN	2	13	T18	LEFT REAR WORK LIGHT (-)	1	11
C421	TILT SPOOL LOCK	3	10	C607	POWER BOBTACH CLOSE	2	13	T19	BACKUP ALARM	1	10
C422	LIFT SPOOL LOCK	3	10	C611	BLOWER MOTOR	4	12	T20	BACKUP ALARM (GND)	1	10
C423	BUCKET POSITION	2	13	C630	THERMOSTAT	3	12				
C425	BRAKE SOLENOID	3	7	C635	HEATER VALVE	6	12				
C426	CAN (Remote Start Tool, ACD)	7	5	C667	DOOR	6	9				
C434-1	LEFT WORKLIGHT 1	2	11	C670	EXTERIOR BEACON	6	13				
C434-2	LEFT WORKLIGHT 2	2	11	C676	RADIO	6	13				
C435-1	RIGHT WORKLIGHT 1	2	11								
C435-2	RIGHT WORKLIGHT 2	2	11								
C437	TWO SPEED MAKEUP	2	7								
C441	TWO SPEED	2	7								

WIRE CATEGORIES FOR COLORS AND NUMBER RANGE			
GROUP DESCRIPTION	GROUP NUMBER RANGE	WIRE COLOR	COLOR CODE
BATT FEED, GENERAL	1000 THROUGH 1499	RED	RED
BATT FEED, FUSED	1000 THROUGH 1499	RED/WHITE	RED/WHT
BATT FEED, SWITCHED	1500 THROUGH 1999	ORANGE/WHITE	RNG/WHT
GROUNDING	2000 THROUGH 2999	BLACK	BLK
MONITORING	3000 THROUGH 3999	LIGHT BLUE	LBL
HYDRAULIC	4000 THROUGH 4999	LIGHT GREEN	LGN
ATTACHMENT CONTROLS	5000 THROUGH 5999	YELLOW	YEL
LIGHTS	6000 THROUGH 6999	PINK	PNK
ACCESSORIES	7000 THROUGH 7999	WHITE	WHT
ENGINE	8000 THROUGH 8999	TAN	TAN
COMMUNICATION	9000 THROUGH 9999	PURPLE	PUR
COMMUNICATION	9000 THROUGH 9999	PURPLE/WHITE	PUR/WHT

SCHEMATIC INDEX	
OVERVIEW	PAGE 1,2
POWER	PAGE 3
GROUND	PAGE 4
CAN BUS	PAGE 5
ENGINE	PAGE 6
HYDRAULICS	PAGE 7
CAB DISPLAY	PAGE 8
CABIN	PAGE 9
CONTROLS	PAGE 10
LIGHTS	PAGE 11
HVAC	PAGE 12
OPTIONS	PAGE 13

[Printable Version Click Here](#)

**WIRING SCHEMATIC  
(SCPA MACHINE)  
T870 (S/N A3PG11001 - A3PG11117)  
(S/N A3PH11001 - A3PH11107)  
Sheet 1 of 13**

(PRINTED DECEMBER 2011)

WIRE CATEGORIES FOR COLORS AND NUMBER RANGE			
GROUP DESCRIPTION	GROUP NUMBER RANGE	WIRE COLOR	COLOR CODE
BATT FEED, GENERAL	1000 THROUGH 1499	RED	RED
BATT FEED, FUSED	1000 THROUGH 1499	RED/WHITE	RED/WHT
BATT FEED, SWITCHED	1500 THROUGH 1999	ORANGE/WHITE	RNG/WHT
GROUNDING	2000 THROUGH 2999	BLACK	BLK
MONITORING	3000 THROUGH 3999	LIGHT BLUE	LBL
HYDRAULIC	4000 THROUGH 4999	LIGHT GREEN	LGN
ATTACHMENT CONTROLS	5000 THROUGH 5999	YELLOW	YEL
LIGHTS	6000 THROUGH 6999	PINK	PNK
ACCESSORIES	7000 THROUGH 7999	WHITE	WHT
ENGINE	8000 THROUGH 8999	TAN	TAN
COMMUNICATION	9000 THROUGH 9999	PURPLE	PUR
COMMUNICATION	9000 THROUGH 9999	PURPLE/WHITE	PUR/WHT

SCHEMATIC INDEX	
OVERVIEW	PAGE
OVERVIEW	PAGE 1,2
POWER	PAGE 3
GROUND	PAGE 4
CAN BUS	PAGE 5
ENGINE	PAGE 6
HYDRAULICS	PAGE 7
CAB DISPLAY	PAGE 8
CAB	PAGE 9
CONTROLS	PAGE 10
LIGHTS	PAGE 11
HVAC	PAGE 12
OPTIONS	PAGE 13

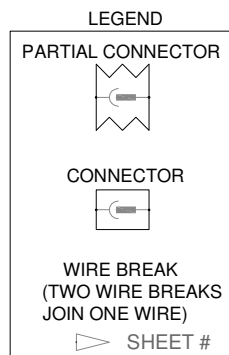

# OPTIONS

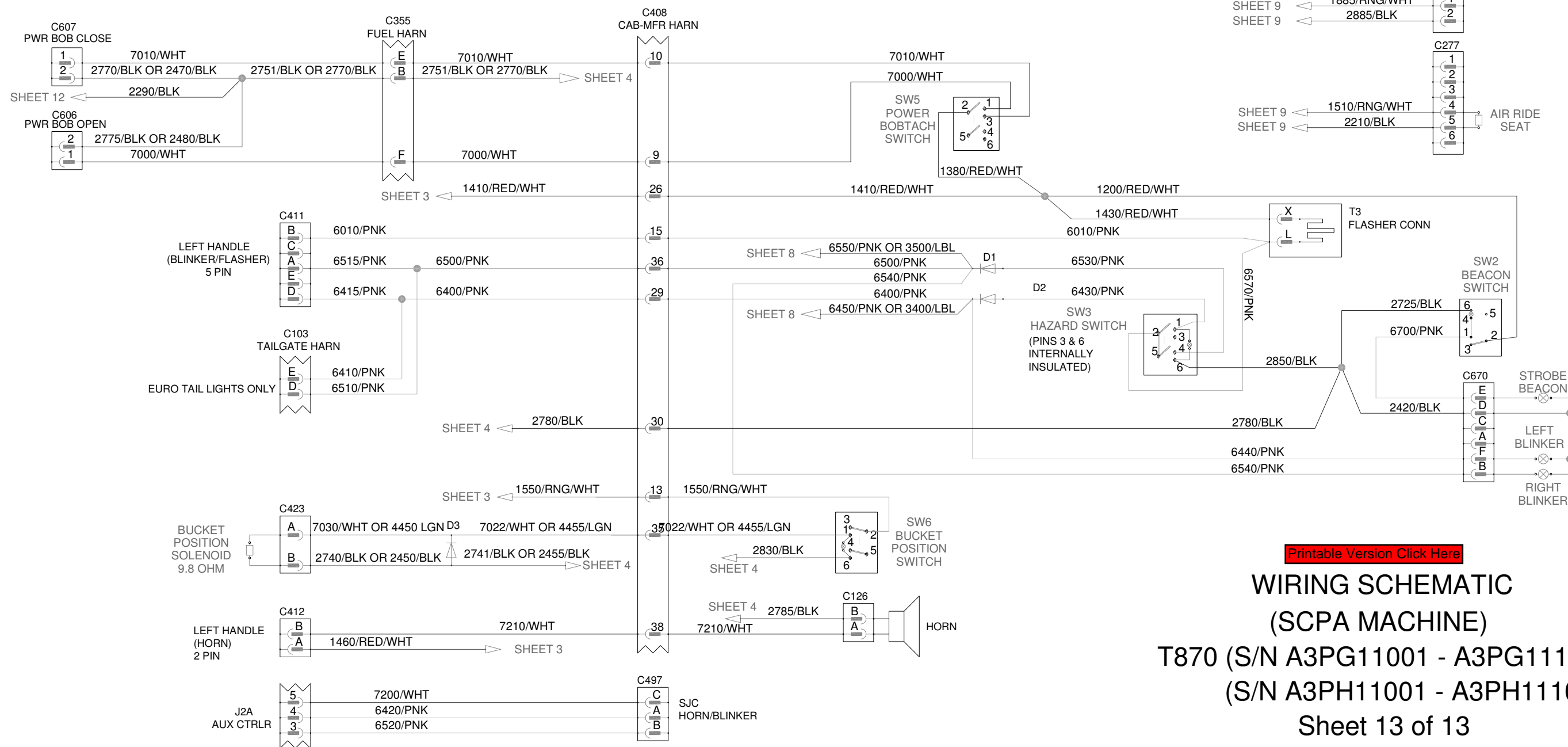

[Printable Version Click Here](#)

**WIRING SCHEMATIC**  
**(SCPA MACHINE)**  
**T870 (S/N A3PG11001 - A3PG11117)**  
**(S/N A3PH11001 - A3PH11107)**  
**Sheet 13 of 13**

(PRINTED DECEMBER 2011)

7190677

WIRE CATEGORIES FOR COLORS AND NUMBER RANGE			
GROUP DESCRIPTION	GROUP NUMBER RANGE	WIRE COLOR	COLOR CODE
BATT FEED, GENERAL	1000 THROUGH 1499	RED	RED
BATT FEED, FUSED	1000 THROUGH 1499	RED/WHITE	RED/WHT
BATT FEED, SWITCHED	1500 THROUGH 1999	ORANGE/WHITE	RNG/WHT
BATTERY GROUND	2000 THROUGH 2999	BLACK	BLK
CONTROLLER GROUND/RETURN	2000 THROUGH 2999	BROWN	BRN
MONITORING	3000 THROUGH 3999	LIGHT BLUE	LBL
HYDRAULIC	4000 THROUGH 4999	LIGHT GREEN	LGN
CONTROLLER SUPPLY	5000 THROUGH 5999	YELLOW	YEL
LIGHTS	6000 THROUGH 6999	PINK	PNK
OTHER FUNCTIONS	7000 THROUGH 7999	WHITE	WHT
ENGINE	8000 THROUGH 8999	TAN	TAN
COMMUNICATION	9000 THROUGH 9999	PURPLE	PUR
COMMUNICATION	9000 THROUGH 9999	PURPLE/WHITE	PUR/WHT

SCHEMATIC INDEX		
OVERVIEW		PAGE 1,2
POWER		PAGE 3
GROUND		PAGE 4
CAN BUS		PAGE 5
ENGINE		PAGE 6
HYDRAULICS		PAGE 7
CAB DISPLAY		PAGE 8
CAB		PAGE 9
CONTROLS		PAGE 10
LIGHTS		PAGE 11
HVAC		PAGE 12
OPTIONS		PAGE 13

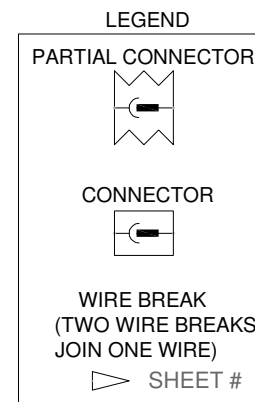

# HVAC

# DLX FUEL HARN 7184255 ONLY  
(NOT IN STD FUEL HARN 7149219)

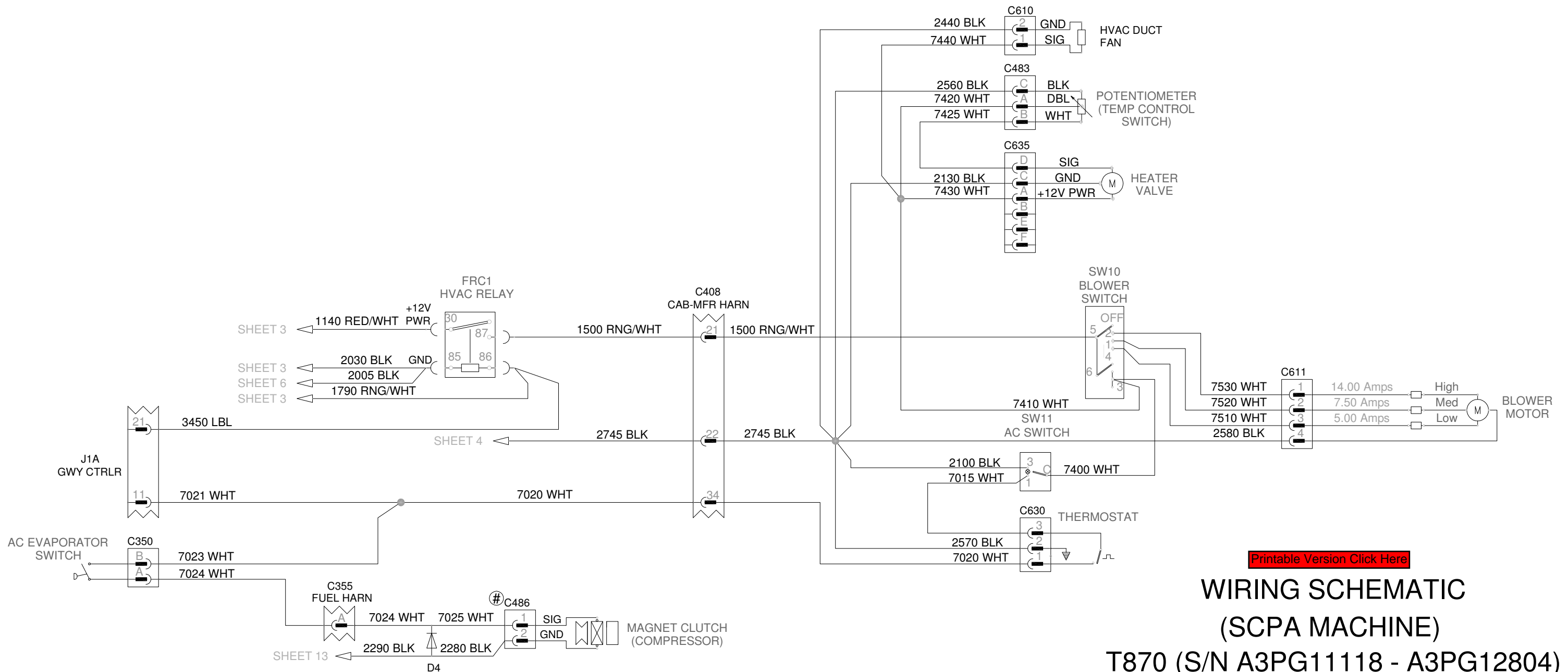

[Printable Version Click Here](#)

**WIRING SCHEMATIC**  
**(SCPA MACHINE)**  
**T870 (S/N A3PG11118 - A3PG12804)**  
**(S/N A3PH11108 - A3PH12325)**

Sheet 12 of 13

(PRINTED AUGUST 2012)

7197685 (B)

WIRE CATEGORIES FOR COLORS AND NUMBER RANGE			
GROUP DESCRIPTION	GROUP NUMBER RANGE	WIRE COLOR	COLOR CODE
BATT FEED, GENERAL	1000 THROUGH 1499	RED	RED
BATT FEED, FUSED	1000 THROUGH 1499	RED/WHITE	RED/WHT
BATT FEED, SWITCHED	1500 THROUGH 1999	ORANGE/WHITE	RNG/WHT
BATTERY GROUND	2000 THROUGH 2999	BLACK	BLK
CONTROLLER GROUND/RETURN	2000 THROUGH 2999	BROWN	BRN
MONITORING	3000 THROUGH 3999	LIGHT BLUE	LBL
HYDRAULIC	4000 THROUGH 4999	LIGHT GREEN	LGN
CONTROLLER SUPPLY	5000 THROUGH 5999	YELLOW	YEL
LIGHTS	6000 THROUGH 6999	PINK	PNK
OTHER FUNCTIONS	7000 THROUGH 7999	WHITE	WHT
ENGINE	8000 THROUGH 8999	TAN	TAN
COMMUNICATION	9000 THROUGH 9999	PURPLE	PUR
COMMUNICATION	9000 THROUGH 9999	PURPLE/WHITE	PUR/WHT

SCHEMATIC INDEX	
OVERVIEW	PAGE 1,2
POWER	PAGE 3
GROUND	PAGE 4
CAN BUS	PAGE 5
ENGINE	PAGE 6
HYDRAULICS	PAGE 7
CAB DISPLAY	PAGE 8
CAB	PAGE 9
CONTROLS	PAGE 10
LIGHTS	PAGE 11
HVAC	PAGE 12
OPTIONS	PAGE 13

LEGEND

PARTIAL CONNECTOR

CONNECTOR

WIRE BREAK (TWO WIRE BREAKS JOIN ONE WIRE)

SHEET #

# LIGHTS

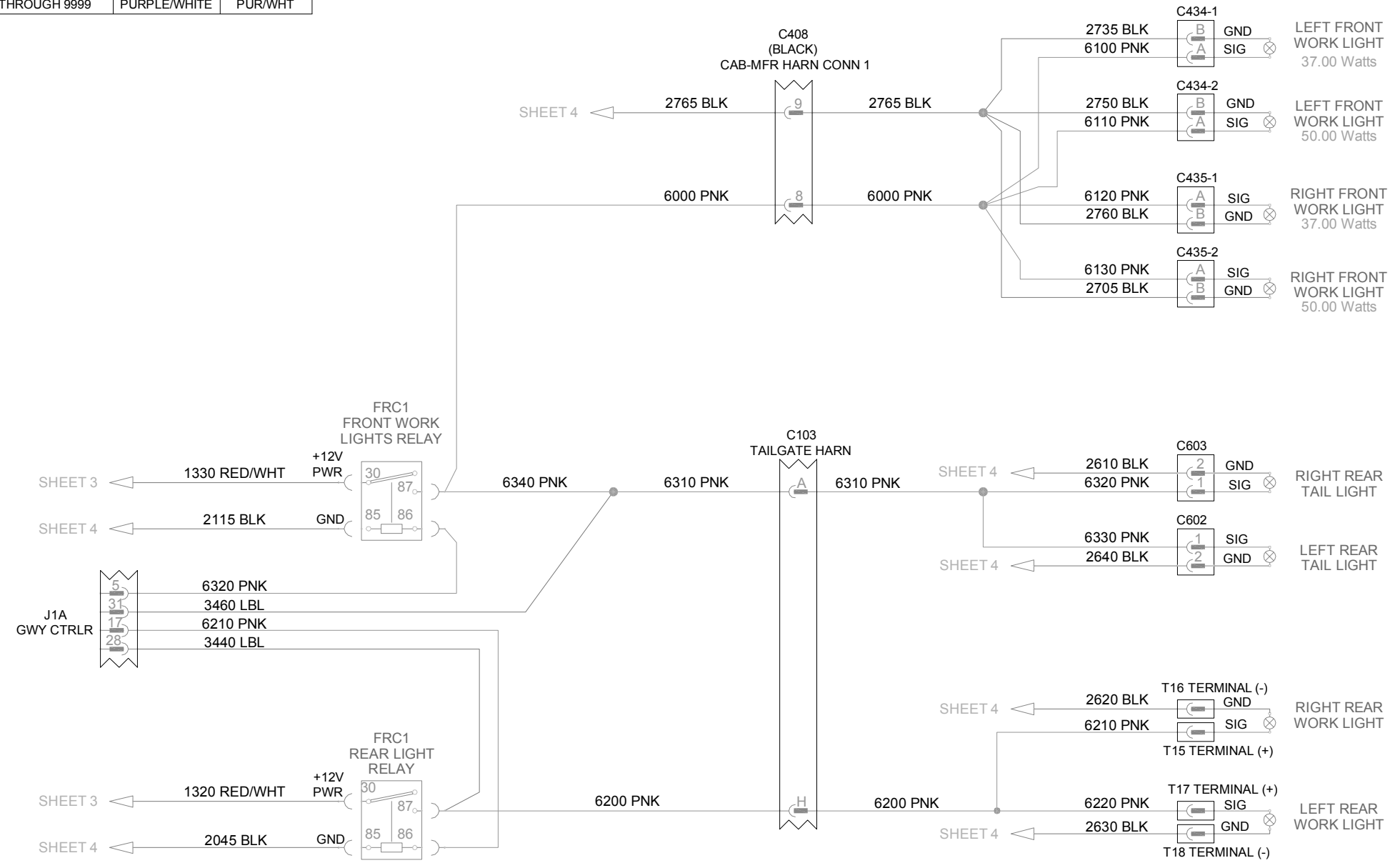

## WIRING SCHEMATIC

(SCPA MACHINE)

[Printable Version Click Here](#)

T870 (S/N A3PG12805 - A3PG12912)

(S/N A3PH12326 - A3PH12530)

Sheet 11 of 13

(PRINTED JANUARY 2017)

7210773 (A)

WIRE CATEGORIES FOR COLORS AND NUMBER RANGE			
GROUP DESCRIPTION	GROUP NUMBER RANGE	WIRE COLOR	COLOR CODE
BATT FEED, GENERAL	1000 THROUGH 1499	RED	RED
BATT FEED, FUSED	1000 THROUGH 1499	RED/WHITE	RED/WHT
BATT FEED, SWITCHED	1500 THROUGH 1999	ORANGE/WHITE	RNG/WHT
BATTERY GROUND	2000 THROUGH 2999	BLACK	BLK
CONTROLLER GROUND/RETURN	2000 THROUGH 2999	BROWN	BRN
MONITORING	3000 THROUGH 3999	LIGHT BLUE	LBL
HYDRAULIC	4000 THROUGH 4999	LIGHT GREEN	LGN
CONTROLLER SUPPLY	5000 THROUGH 5999	YELLOW	YEL
LIGHTS	6000 THROUGH 6999	PINK	PNK
OTHER FUNCTIONS	7000 THROUGH 7999	WHITE	WHT
ENGINE	8000 THROUGH 8999	TAN	TAN
COMMUNICATION	9000 THROUGH 9999	PURPLE	PUR
COMMUNICATION	9000 THROUGH 9999	PURPLE/WHITE	PUR/WHT

SCHEMATIC INDEX	
OVERVIEW	PAGE 1.2
POWER	PAGE 3
GROUND	PAGE 4
CAN BUS	PAGE 5
ENGINE	PAGE 6
HYDRAULICS	PAGE 7
CAB DISPLAY	PAGE 8
CAB	PAGE 9
CONTROLS	PAGE 10
LIGHTS	PAGE 11
HVAC	PAGE 12
OPTIONS	PAGE 13

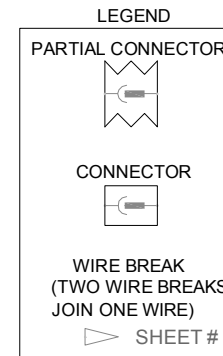

# CONTROLS

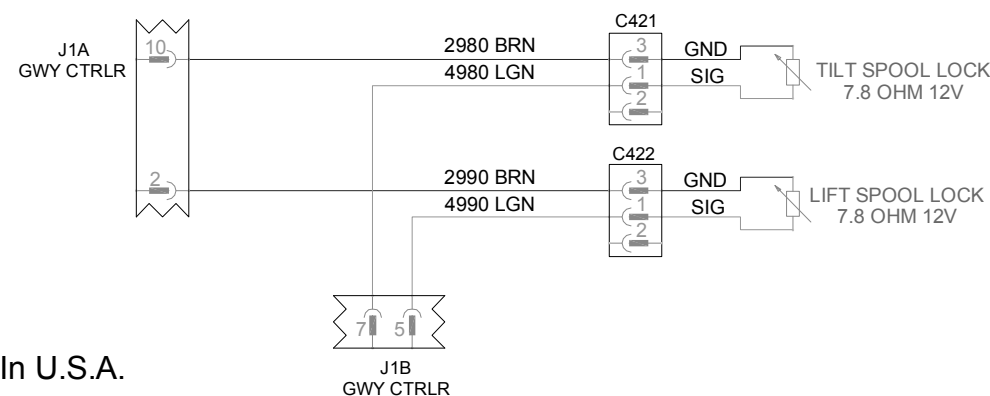
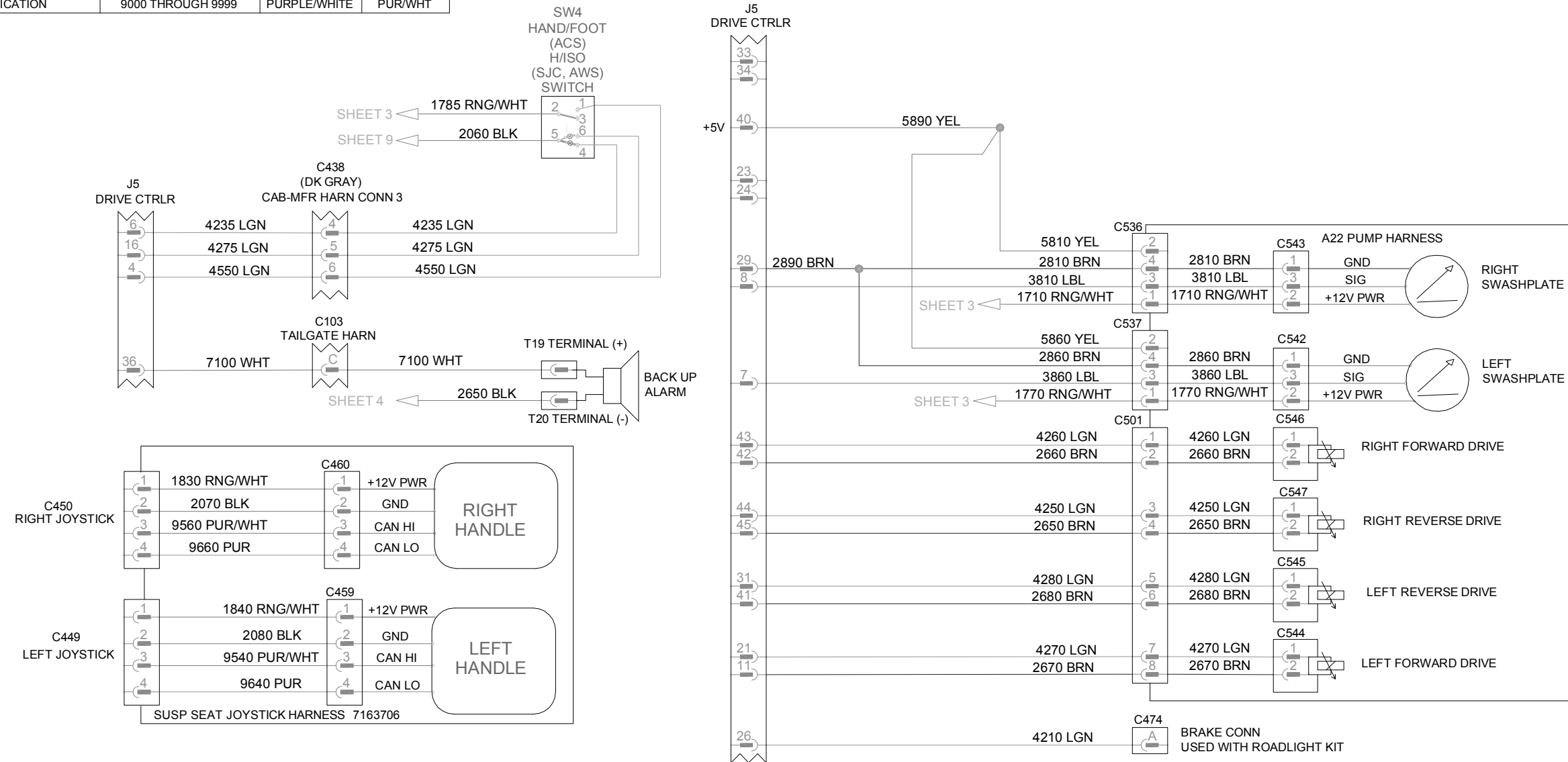

**WIRING SCHEMATIC**  
**(SCPA MACHINE)** [Printable Version Click Here](#)  
**T870 (S/N A3PG12913 - A3PG12916)**  
**(S/N A3PH12531 - A3PH12540)**  
**Sheet 10 of 13**  
**(PRINTED JANUARY 2017)**  
**7210773 (B)**

WIRE CATEGORIES FOR COLORS AND NUMBER RANGE			
GROUP DESCRIPTION	GROUP NUMBER RANGE	WIRE COLOR	COLOR CODE
BATT FEED, GENERAL	1000 THROUGH 1499	RED	RED
BATT FEED, FUSED	1000 THROUGH 1499	RED/WHITE	RED/WHT
BATT FEED, SWITCHED	1500 THROUGH 1999	ORANGE/WHITE	RNG/WHT
BATTERY GROUND	2000 THROUGH 2999	BLACK	BLK
CONTROLLER GROUND/RETURN	2000 THROUGH 2999	BROWN	BRN
MONITORING	3000 THROUGH 3999	LIGHT BLUE	LBL
HYDRAULIC	4000 THROUGH 4999	LIGHT GREEN	LGN
CONTROLLER SUPPLY	5000 THROUGH 5999	YELLOW	YEL
LIGHTS	6000 THROUGH 6999	PINK	PNK
OTHER FUNCTIONS	7000 THROUGH 7999	WHITE	WHT
ENGINE	8000 THROUGH 8999	TAN	TAN
COMMUNICATION	9000 THROUGH 9999	PURPLE	PUR
COMMUNICATION	9000 THROUGH 9999	PURPLE/WHITE	PUR/WHT

SCHEMATIC INDEX	
OVERVIEW	PAGE 1,2
POWER	PAGE 3
GROUND	PAGE 4
CAN BUS	PAGE 5
ENGINE	PAGE 6
HYDRAULICS	PAGE 7
CAB DISPLAY	PAGE 8
CAB	PAGE 9
CONTROLS	PAGE 10
LIGHTS	PAGE 11
HVAC	PAGE 12
OPTIONS	PAGE 13

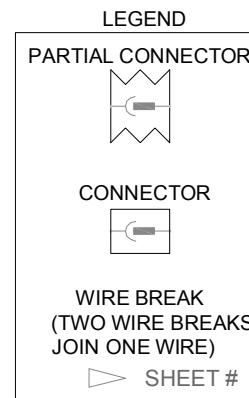

# CAB

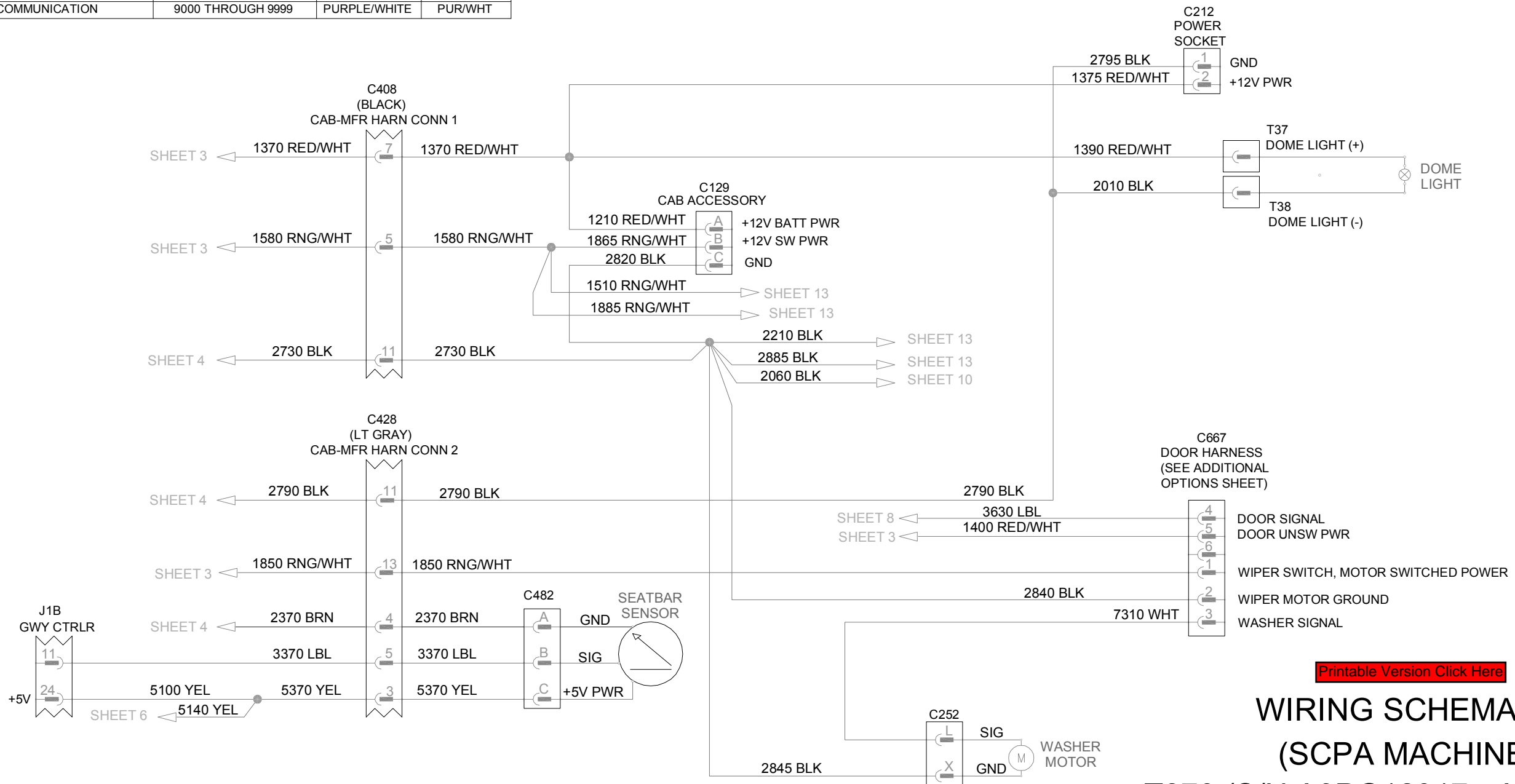

[Printable Version Click Here](#)

## WIRING SCHEMATIC (SCPA MACHINE) T870 (S/N A3PG12917 - A3PG13699) (S/N A3PH12541 - A3PH12933) Sheet 9 of 13

(PRINTED JANUARY 2017)

7210773 (C)

# CAB DISPLAY

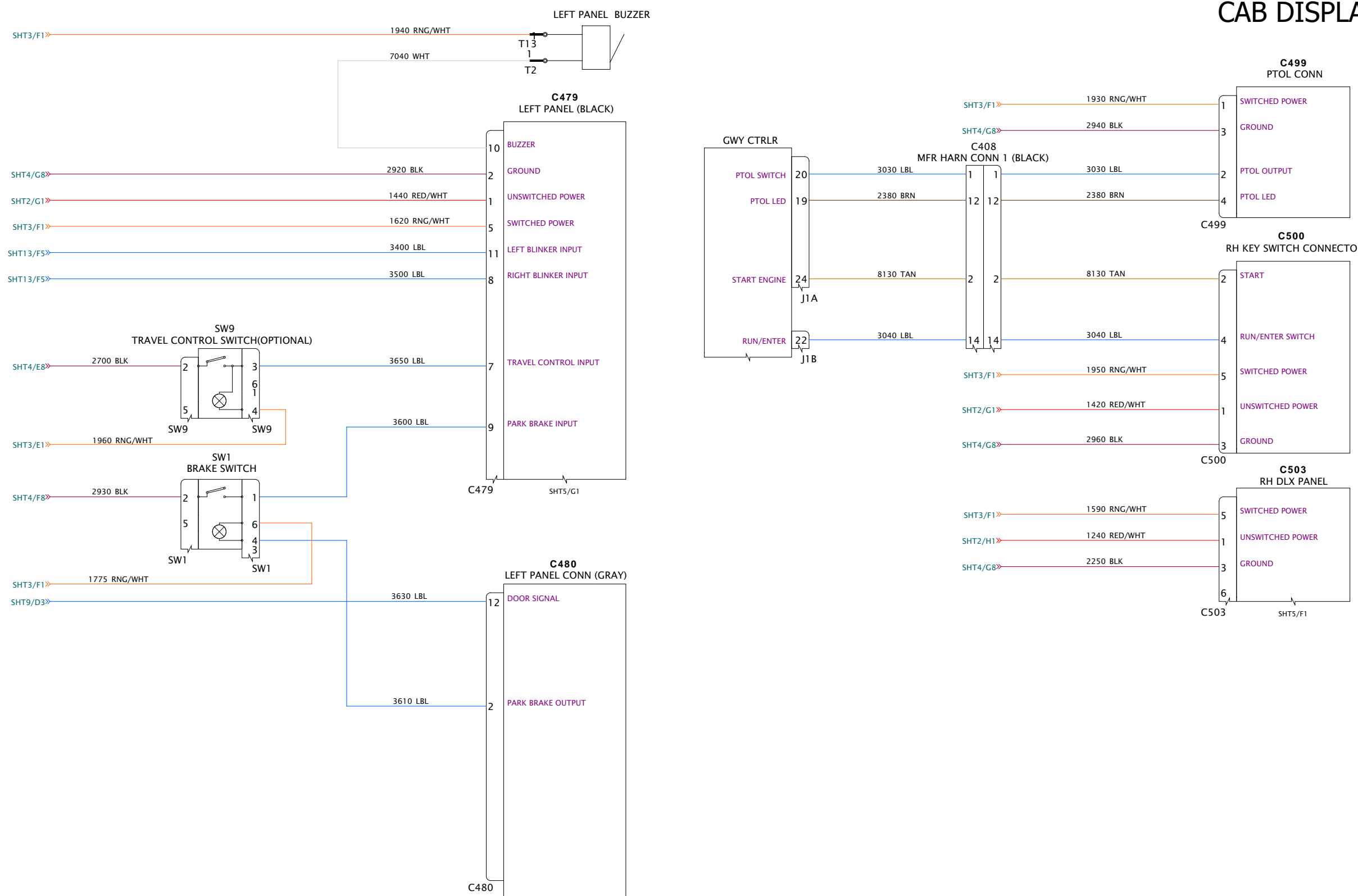

WIRE CATEGORIES FOR COLORS AND NUMBER RANGE			
GROUP DESCRIPTION	GROUP NUMBER RANGE	WIRE COLOR	COLOR CODE
BATT FEED, GENERAL	1000 THROUGH 1499	RED	RED
BATT FEED, FUSED	1000 THROUGH 1499	RED/WHITE	RED/WHT
BATT FEED, SWITCHED	1500 THROUGH 1999	ORANGE/WHITE	RNG/WHT
GROUNDING	2000 THROUGH 2999	BLACK	BLK
MONITORING	3000 THROUGH 3999	LIGHT BLUE	LBL
HYDRAULIC	4000 THROUGH 4999	LIGHT GREEN	LGN
ATTACHMENT CONTROLS	5000 THROUGH 5999	YELLOW	YEL
LIGHTS	6000 THROUGH 6999	PINK	PNK
ACCESSORIES	7000 THROUGH 7999	WHITE	WHT
ENGINE	8000 THROUGH 8999	TAN	TAN
COMMUNICATION	9000 THROUGH 9999	PURPLE	PUR
COMMUNICATION	9000 THROUGH 9999	PURPLE/WHITE	PUR/WHT

SCHEMATIC INDEX	
OVERVIEW	PAGE 1,2
POWER	PAGE 3
GROUND	PAGE 4
CAN BUS	PAGE 5
ENGINE	PAGE 6
HYDRAULICS	PAGE 7
CAB DISPLAY	PAGE 8
CAB	PAGE 9
CONTROLS	PAGE 10
LIGHTS	PAGE 11
HVAC	PAGE 12
OPTIONS	PAGE 13

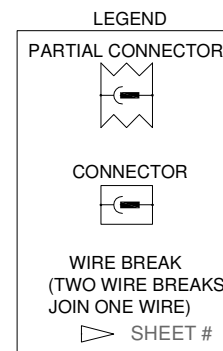

# ENGINE

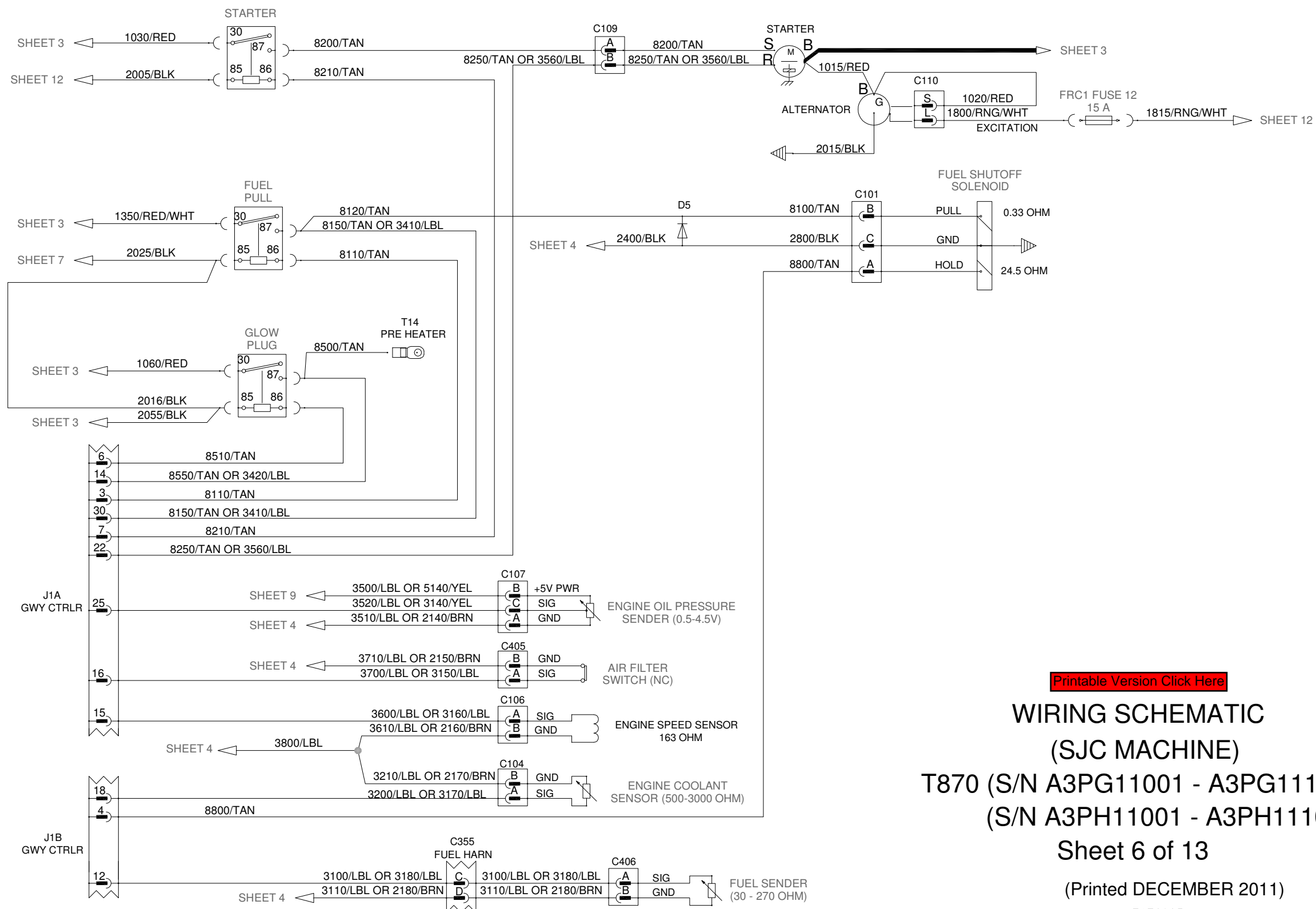

[Printable Version Click Here](#)

## WIRING SCHEMATIC (SJC MACHINE) T870 (S/N A3PG11001 - A3PG11117) (S/N A3PH11001 - A3PH11107) Sheet 6 of 13

(Printed DECEMBER 2011)

7176903

WIRE CATEGORIES FOR COLORS AND NUMBER RANGE			
GROUP DESCRIPTION	GROUP NUMBER RANGE	WIRE COLOR	COLOR CODE
BATT FEED, GENERAL	1000 THROUGH 1499	RED	RED
BATT FEED, FUSED	1000 THROUGH 1499	RED/WHITE	RED/WHT
BATT FEED, SWITCHED	1500 THROUGH 1999	ORANGE/WHITE	RNG/WHT
BATTERY GROUND	2000 THROUGH 2999	BLACK	BLK
CONTROLLER GROUND/RETURN	2000 THROUGH 2999	BROWN	BRN
MONITORING	3000 THROUGH 3999	LIGHT BLUE	LBL
HYDRAULIC	4000 THROUGH 4999	LIGHT GREEN	LGN
CONTROLLER SUPPLY	5000 THROUGH 5999	YELLOW	YEL
LIGHTS	6000 THROUGH 6999	PINK	PNK
OTHER FUNCTIONS	7000 THROUGH 7999	WHITE	WHT
ENGINE	8000 THROUGH 8999	TAN	TAN
COMMUNICATION	9000 THROUGH 9999	PURPLE	PUR
COMMUNICATION	9000 THROUGH 9999	PURPLE/WHITE	PUR/WHT

SCHEMATIC INDEX	
OVERVIEW	PAGE 1,2
POWER	PAGE 3
GROUND	PAGE 4
CAN BUS	PAGE 5
ENGINE	PAGE 6
HYDRAULICS	PAGE 7
CAB DISPLAY	PAGE 8
CAB	PAGE 9
CONTROLS	PAGE 10
LIGHTS	PAGE 11
HVAC	PAGE 12
OPTIONS	PAGE 13

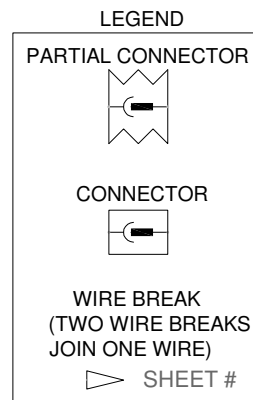

# CAN BUS

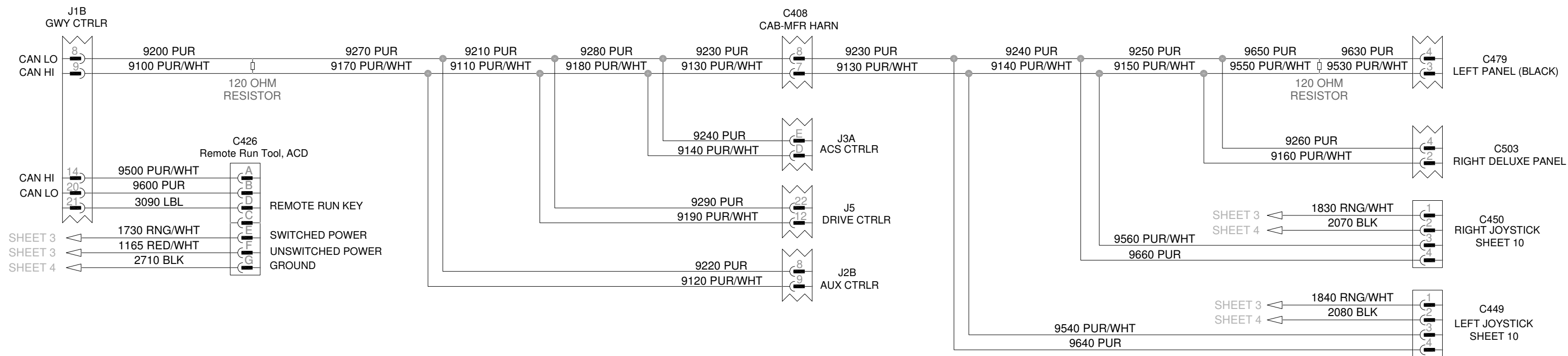

[Printable Version Click Here](#)

## WIRING SCHEMATIC (SJC MACHINE)

T870 (S/N A3PG11118 - A3PG12804)  
 (S/N A3PH11108 - A3PH12325)

Sheet 5 of 13

(PRINTED AUGUST 2012)

WIRE CATEGORIES FOR COLORS AND NUMBER RANGE			
GROUP DESCRIPTION	GROUP NUMBER RANGE	WIRE COLOR	COLOR CODE
BATT FEED, GENERAL	1000 THROUGH 1499	RED	RED
BATT FEED, FUSED	1000 THROUGH 1499	RED/WHITE	RED/WHT
BATT FEED, SWITCHED	1500 THROUGH 1999	ORANGE/WHITE	RNG/WHT
BATTERY GROUND	2000 THROUGH 2999	BLACK	BLK
CONTROLLER GROUND/RETURN	2000 THROUGH 2999	BROWN	BRN
MONITORING	3000 THROUGH 3999	LIGHT BLUE	LBL
HYDRAULIC	4000 THROUGH 4999	LIGHT GREEN	LGN
CONTROLLER SUPPLY	5000 THROUGH 5999	YELLOW	YEL
LIGHTS	6000 THROUGH 6999	PINK	PNK
OTHER FUNCTIONS	7000 THROUGH 7999	WHITE	WHT
ENGINE	8000 THROUGH 8999	TAN	TAN
COMMUNICATION	9000 THROUGH 9999	PURPLE	PUR
COMMUNICATION	9000 THROUGH 9999	PURPLE/WHITE	PUR/WHT

SCHEMATIC INDEX	
OVERVIEW	PAGE 1,2
POWER	PAGE 3
GROUND	PAGE 4
CAN BUS	PAGE 5
ENGINE	PAGE 6
HYDRAULICS	PAGE 7
CAB DISPLAY	PAGE 8
CAB	PAGE 9
CONTROLS	PAGE 10
LIGHTS	PAGE 11
HVAC	PAGE 12
OPTIONS	PAGE 13

LEGEND

PARTIAL CONNECTOR  

CONNECTOR  

WIRE BREAK  
 (TWO WIRE BREAKS JOIN ONE WIRE)  
 SHEET #

# GROUND

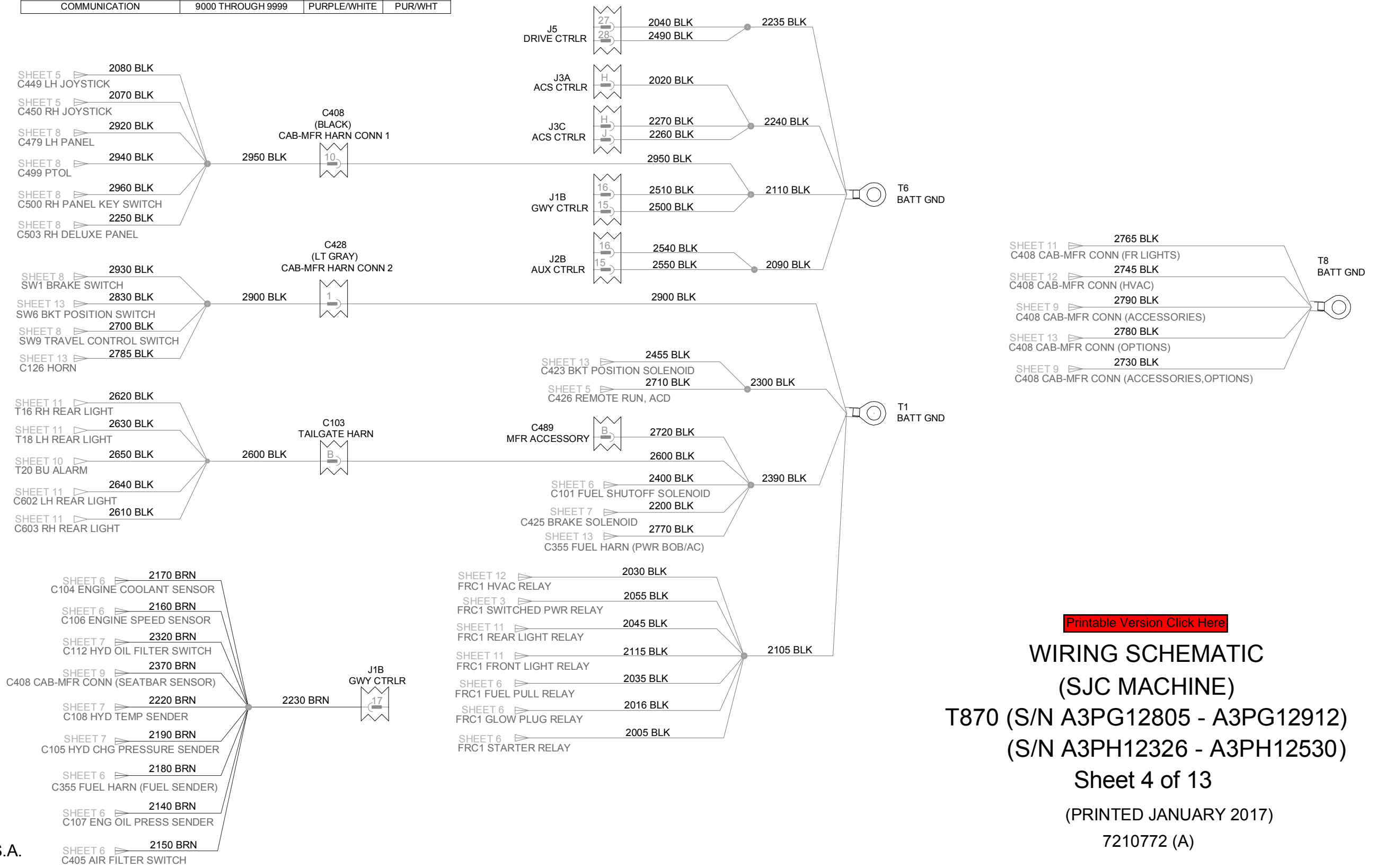

[Printable Version Click Here](#)

**WIRING SCHEMATIC**  
**(SJC MACHINE)**  
**T870 (S/N A3PG12805 - A3PG12912)**  
**(S/N A3PH12326 - A3PH12530)**  
 Sheet 4 of 13

(PRINTED JANUARY 2017)

7210772 (A)

# POWER

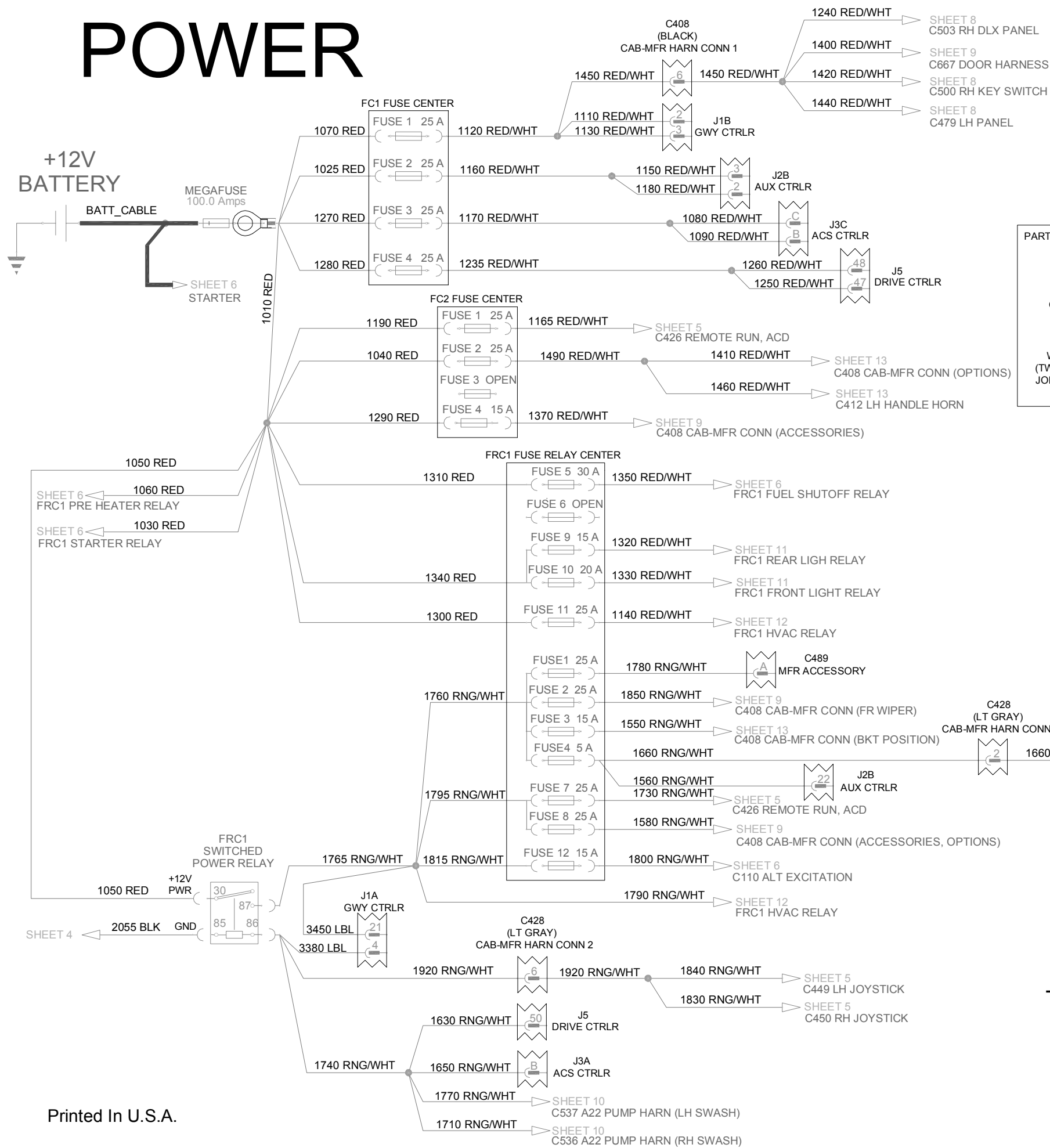

WIRE CATEGORIES FOR COLORS AND NUMBER RANGE			
GROUP DESCRIPTION	GROUP NUMBER RANGE	WIRE COLOR	COLOR CODE
BATT FEED, GENERAL	1000 THROUGH 1499	RED	RED
BATT FEED, FUSED	1000 THROUGH 1499	RED/WHITE	RED/WHT
BATT FEED, SWITCHED	1500 THROUGH 1999	ORANGE/WHITE	RNG/WHT
BATTERY GROUND	2000 THROUGH 2999	BLACK	BLK
CONTROLLER GROUND/RETURN	2000 THROUGH 2999	BROWN	BRN
MONITORING	3000 THROUGH 3999	LIGHT BLUE	LBL
HYDRAULIC	4000 THROUGH 4999	LIGHT GREEN	LGN
CONTROLLER SUPPLY	5000 THROUGH 5999	YELLOW	YEL
LIGHTS	6000 THROUGH 6999	PINK	PNK
OTHER FUNCTIONS	7000 THROUGH 7999	WHITE	WHT
ENGINE	8000 THROUGH 8999	TAN	TAN
COMMUNICATION	9000 THROUGH 9999	PURPLE	PUR
COMMUNICATION	9000 THROUGH 9999	PURPLE/WHITE	PUR/WHT

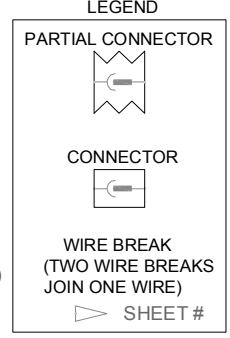

SCHEMATIC INDEX	
OVERVIEW	PAGE 1,2
POWER	PAGE 3
GROUND	PAGE 4
CAN BUS	PAGE 5
ENGINE	PAGE 6
HYDRAULICS	PAGE 7
CAB DISPLAY	PAGE 8
CAB	PAGE 9
CONTROLS	PAGE 10
LIGHTS	PAGE 11
HVAC	PAGE 12
OPTIONS	PAGE 13

## WIRING SCHEMATIC

(SJC MACHINE) [Printable Version Click Here](#)

T870 (S/N A3PG12913 - A3PG12916)

(S/N A3PH12531 - A3PH12540)

Sheet 3 of 13

(PRINTED JANUARY 2017)

7210772 (B)



Index	Diagram
1	SH01 - INDEX
2	SH02 - UNSWITCHED BATT POWER
3	SH03 - SWITCHED POWER
4	SH04 - GROUND
5	SH05 - CAN BUS
6	SH06 - ENGINE
7	SH07 - HYDRAULICS
8	SH08 - CAB DISPLAY
9	SH09 - CAB
10	SH10 - CONTROLS
11	SH11 - LIGHTS
12	SH12 - HVAC
13	SH13 - OPTIONS 1
14	SH14 - OPTIONS 2

HARNESS PART NUMBER	
MFR SJC	7305825
DLX CAB	7304511
S/R	6733370
TAILGATE DOM	7217484
A22 PUMP	7198705
SUSP JSTK	7163706
TRK BRK ADP	7165061
WHL 2 SPD ADP	7165061

WIRE CATEGORIES FOR COLORS AND NUMBER RANGE			
GROUP DESCRIPTION	GROUP NUMBER RANGE	WIRE COLOR	COLOR CODE
BATT FEED, GENERAL	1000 THROUGH 1499	RED	RED
BATT FEED, FUSED	1000 THROUGH 1499	RED/WHITE	RED/WHT
BATT FEED, SWITCHED	1500 THROUGH 1999	ORANGE/WHITE	RNG/WHT
BATTERY GROUND	2000 THROUGH 2999	BLACK	BLK
CONTROLLER GROUND	2000 THROUGH 2999	BROWN	BRN
MONITORING	3000 THROUGH 3999	LIGHT BLUE	LBL
HYDRAULIC	4000 THROUGH 4999	LIGHT GREEN	LGN
CONTROLLER SUPPLY (5V, 8V)	5000 THROUGH 5999	YELLOW	YEL
LIGHTS	6000 THROUGH 6999	PINK	PNK
OTHER FUNCTIONS	7000 THROUGH 7999	WHITE	WHT
ENGINE	8000 THROUGH 8999	TAN	TAN
COMMUNICATION CAN LO	90XX, 92XX, 94XX, 96XX, 98XX	PURPLE	PUR
COMMUNICATION CAN HI	91XX, 93XX, 95XX, 97XX, 99XX	PURPLE/WHITE	PUR/WHT

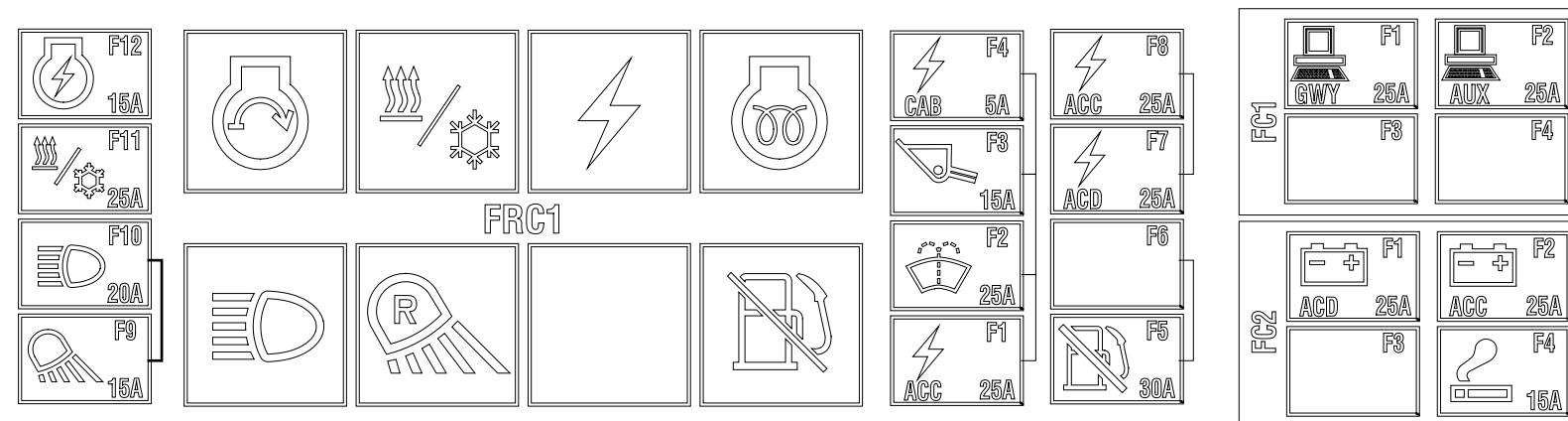
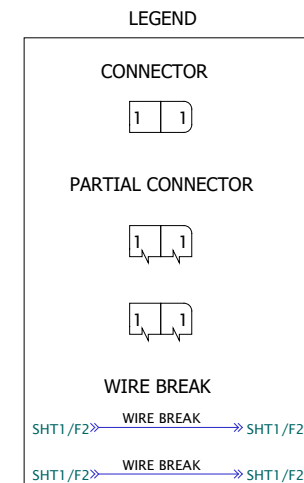

# OPTIONS 1

- # DLX FUEL HARN 7266824 ONLY  
(NOT IN STD FUEL HARN 7149219)
- \* DLX CAB HARN 7304511 ONLY  
(NOT IN STD CAB HARN 7210557)

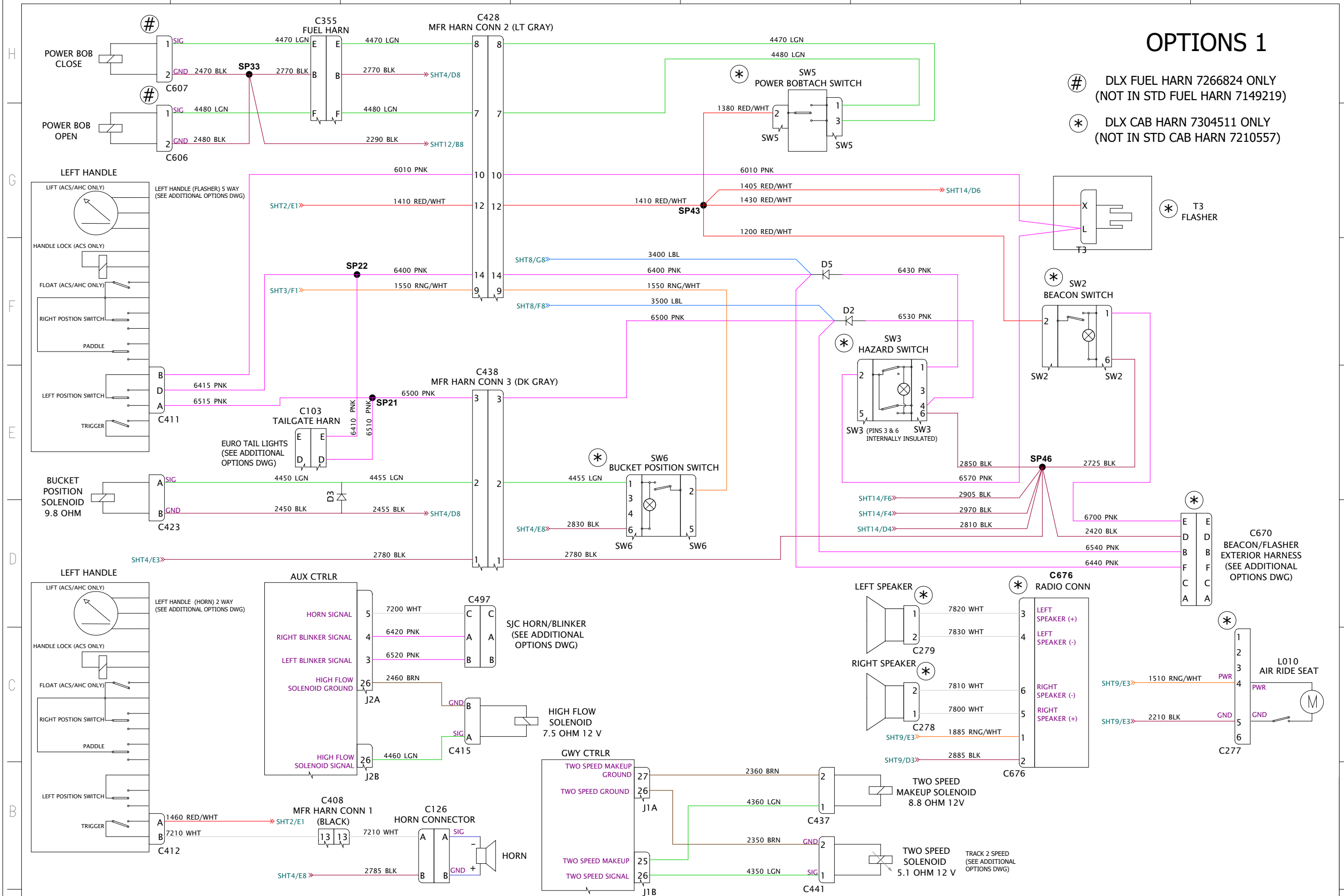

**Wiring Schematic  
SJC Machine**

**T870 S/N A3PG13700 & Above  
S/N A3PH12934 & Above**

**Printed On February 2017  
7305826\_0  
Sheet 13 of 14**

[Printable Version Click Here](#)

ELECTRICAL SYSTEM INFORMATION (CONT'D)

SJC Mainframe Harness Connectors (Later Models)

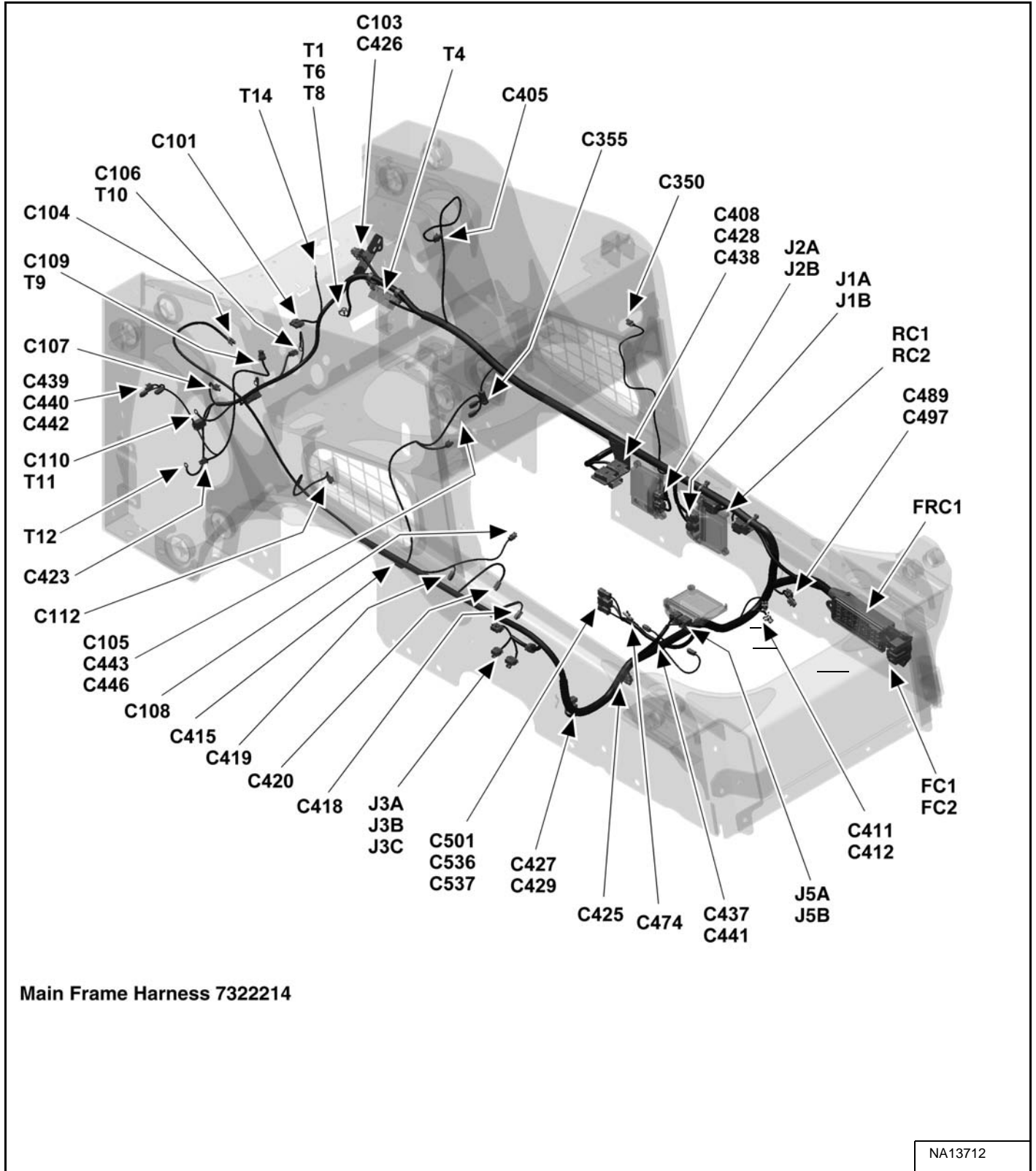

Main Frame Harness 7322214

NA13712

## BATTERY (CONT'D)

### Using A Booster Battery (Jump Starting)

If it is necessary to use a booster battery to start the engine, BE CAREFUL! There must be one person in the operator's seat and one person to connect and disconnect the battery cables.

The key switch must be OFF or the STOP button must be pressed. The booster battery must be 12 volt.

## WARNING

### BATTERY GAS CAN EXPLODE AND CAUSE SERIOUS INJURY OR DEATH

Keep arcs, sparks, flames and lighted tobacco away from batteries. When *jumping* from booster battery make final connection (negative) at machine frame.

Do not jump start or charge a frozen or damaged battery. Warm battery to 16°C (60°F) before connecting to a charger. Unplug charger before connecting or disconnecting cables to battery. Never lean over battery while boosting, testing or charging.

W-2066-0910

Figure 60-20-4

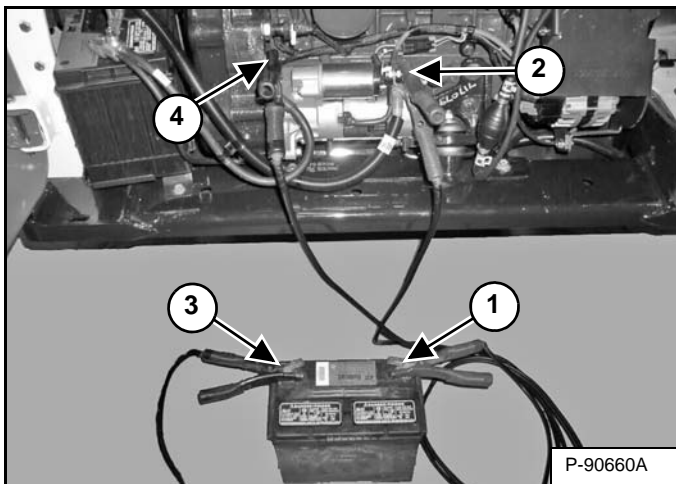

Connect the end of the first cable (Item 1) [Figure 60-20-4] to the positive (+) terminal of the booster battery. Connect the other end of the same cable (Item 2) [Figure 60-20-4] to the positive terminal on the loader starter.

Connect the end of the second cable (Item 3) [Figure 60-20-4] to the negative terminal of the booster battery. Connect the other end of the same cable (Item 4) [Figure 60-20-4] to the engine.

Keep cables away from moving parts. Start the engine.

After the engine has started, remove the negative (-) cable (Item 4) [Figure 60-20-4] first. Remove the cable from the positive terminal (Item 2) [Figure 60-20-4].

## IMPORTANT

Damage to the alternator can occur if:

- Engine is operated with battery cables disconnected.
- Battery cables are connected when using a fast charger or when welding on the loader. (Remove both cables from the battery.)
- Extra battery cables (booster cables) are connected wrong.

I-2023-1285

## INSTRUMENT PANELS (CONT'D)

### Left Panel (Later Models)

Figure 60-50-2

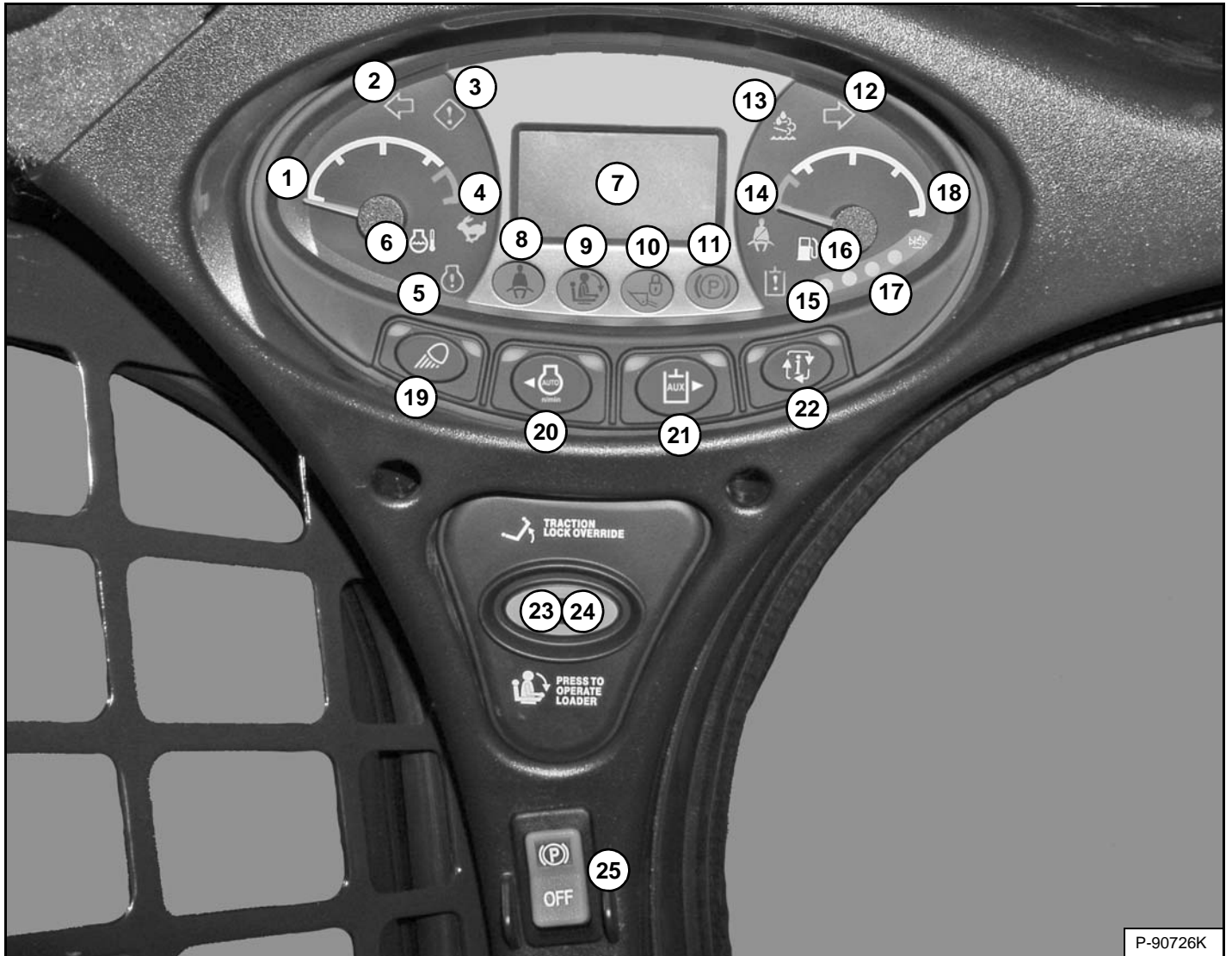

P-90726K

The left panel [Figure 60-50-2] is the same for all machines regardless of options and accessories.

REF. NO.	DESCRIPTION	FUNCTION / OPERATION
1	ENGINE TEMPERATURE GAUGE	Shows the engine coolant temperature.
2	LEFT TURN SIGNAL (Option)	Indicates left turn signals are ON.
3	GENERAL WARNING	Malfunction with one or more machine functions. (See Service Codes*)
4	TWO-SPEED	High range selected.
5	ENGINE MALFUNCTION	Engine malfunction or failure. (See Service Codes*)
6	ENGINE COOLANT TEMPERATURE	Engine coolant temperature high or sensor error.
7	DISPLAY SCREEN	Displays information. (See Display Screen in this manual.)
8	SEAT BELT	Instructs operator to fasten seat belt. Remains lit for 45 seconds.
9	SEAT BAR	The light is on when the seat bar is UP.
10	LIFT AND TILT VALVE	The light is on when the lift and tilt functions cannot be operated.
11	PARKING BRAKE	The light is on when the loader cannot be driven.

## LIGHTS

### Front Removal And Installation

Disconnect the negative(-) cable from the battery. (See Removal And Installation on Page 60-20-1.)

Figure 60-60-1

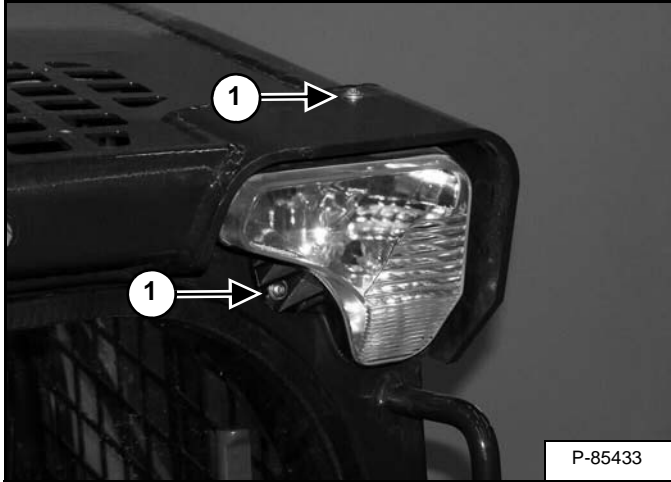

Remove the two bolts (Item 1) [Figure 60-60-1].

Figure 60-60-2

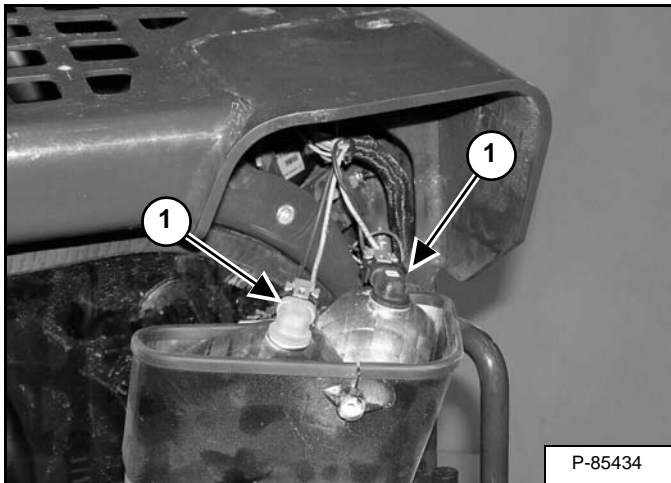

Disconnect the bulbs (Item 1) [Figure 60-60-2] from the wire harness connectors.

Figure 60-60-3

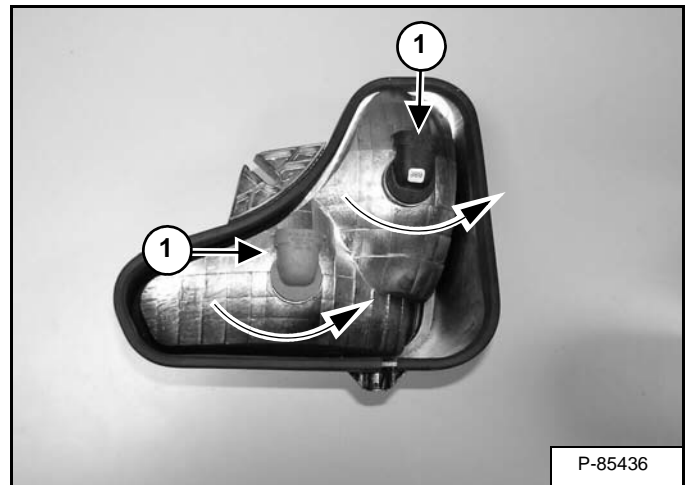
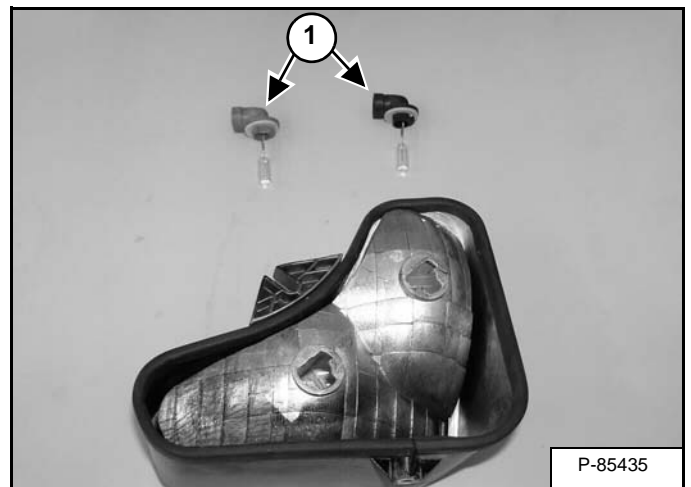

Figure 60-60-4



Remove the two bulbs (Item 1) [Figure 60-60-3] and [Figure 60-60-4] from the housing by turning bulb a 1/4 turn.

**NOTE:** Two different light bulbs are used, take note when removing to assure correct installation.

## BOBCAT CONTROLLERS (GATEWAY AND AUXILIARY) (CONT'D)

### Removal And Installation (Later Models)

Raise the lift arms and install an approved lift arm support device. (See Installing on Page 10-20-1.)

Lift and block the loader. (See Procedure on Page 10-10-1.)

Raise the operator cab. (See Raising on Page 10-30-2.)

**Figure 60-70-3**

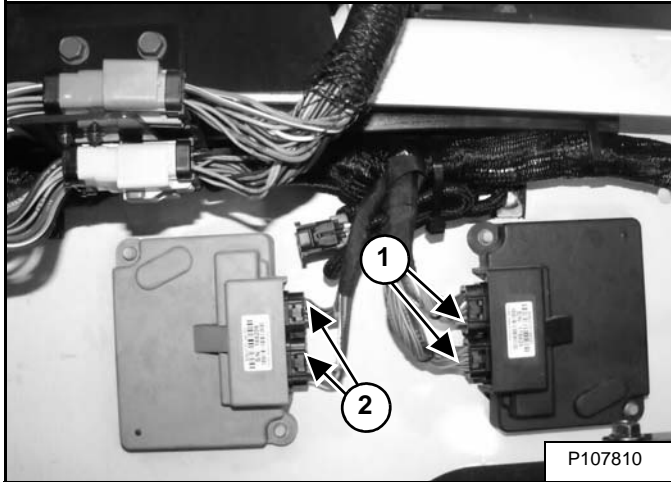

Unplug the two harness connectors (Item 1) [Figure 60-70-3] from the Gateway controller.

Unplug the two harness connectors (Item 2) [Figure 60-70-3] from the Auxiliary controller.

**NOTE:** The connectors are keyed and will only plug in one way.

**Figure 60-70-4**

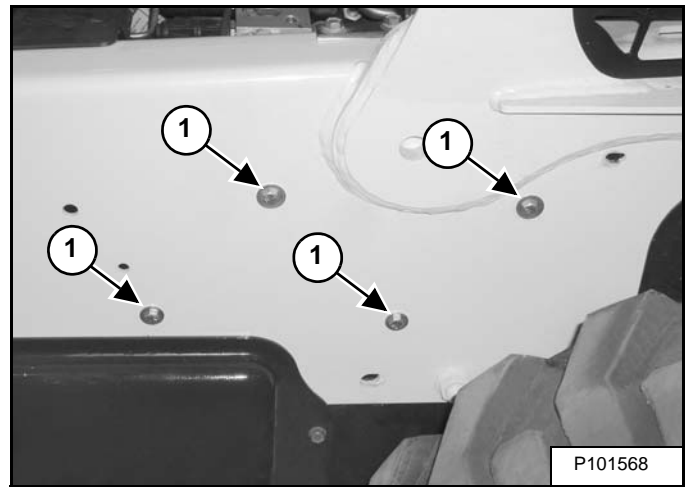

Remove the controller mounting bolts (Item 1) [Figure 60-70-4] from the left fender.

**Installation:** Tighten the controller mounting bolts to 16 - 19 N•m (12 - 14 ft-lb) torque.

Remove the Gateway and Auxiliary controllers from the loader.

**BOBCAT CONTROLLER (SJC) (DRIVE) (CONT'D)****Connector Identification (Later Models) (Cont'd)**

J5A

<b>PIN</b>	<b>WIRE NUMBER</b>	<b>COLOR</b>	<b>DESCRIPTION</b>
1	OPEN	NA	NA
2	OPEN	NA	NA
3	OPEN	NA	NA
4	OPEN	NA	NA
5	OPEN	NA	NA
6	4275	LGN	FOOT CONTROL
7	OPEN	NA	NA
8	4235	LGN	HAND CONTROL LIGHT
9	4210	LGN	BRAKE LIGHT SIGNAL
10	2670	BRN	LEFT FWD GROUND
11	OPEN	NA	NA
12	OPEN	NA	NA
13	OPEN	NA	NA
14	OPEN	NA	NA
15	OPEN	NA	NA
16	OPEN	NA	NA
17	7100	WHT	BACK-UP ALARM POWER
18	2680	BRN	LEFT REV GROUND
19	OPEN	NA	NA
20	OPEN	NA	NA
21	4550	LGN	FOOT CONTROL SIGNAL
22	OPEN	NA	NA
23	OPEN	NA	NA
24	OPEN	NA	NA
25	OPEN	NA	NA
26	2660	BRN	RIGHT FWD GROUND
27	2650	BRN	RIGHT REV GROUND
28	OPEN	NA	NA
29	OPEN	NA	NA
30	OPEN	NA	NA
31	OPEN	NA	NA
32	OPEN	NA	NA
33	OPEN	NA	NA
34	OPEN	NA	NA

## BOBCAT CONTROLLER (SCPA) (DRIVE) (CONT'D)

### Removal And Installation (Later Models)

Raise the operator cab. (See Raising on Page 10-30-2.)

Figure 60-73-1

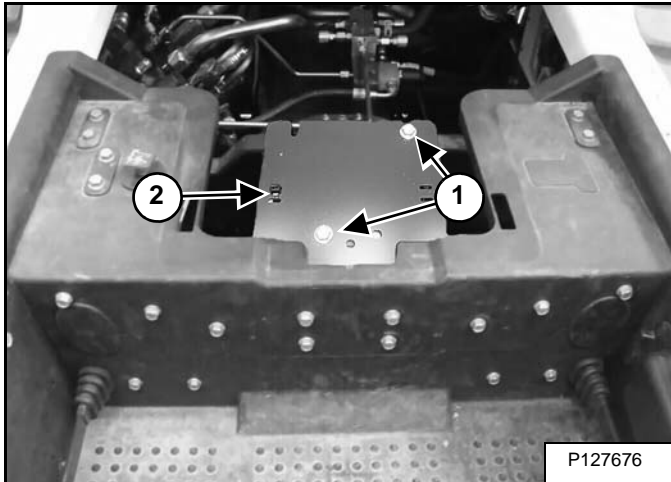

Remove the two bolts (Item 1) [Figure 60-73-1] that secure the controller.

Remove the tie strap (Item 2) [Figure 60-73-1].

**Installation:** Tighten the mounting bolts to 17 - 19 N•m (12 - 14 ft-lb) torque.

Figure 60-73-2



Unplug the two harness connectors and remove the drive controller from the loader [Figure 60-73-2].

**NOTE:** The connectors are keyed and will only plug in one way.

**DIAGNOSTIC SERVICE CODES (CONT'D)****Service Codes List (Cont'd)**

<b>CODE</b>	<b>DESCRIPTION</b>	<b>CODE</b>	<b>DESCRIPTION</b>
M3506	Hydraulic fan short to ground	M5902	DPF regeneration switch error ON
M3507	Hydraulic fan open circuit	M6002	DPF inhibit regeneration switch error ON
M3532	Hydraulic fan overcurrent	M6102	Remote parked regeneration switch error ON
M3705	Two-speed second output short to battery	M6402	Switched power relay error ON
M3706	Two-speed second output short to ground	M6403	Switched power relay error OFF
M3707	Two-speed second output open circuit	M6505	ECU power short to battery
M3732	Two-speed second output overcurrent	M6506	ECU power short to ground
M3805	Auxiliary hydraulic lock short to battery	M6507	ECU power open circuit
M3806	Auxiliary hydraulic lock short to ground	M6604	ECU no communication
M3807	Auxiliary hydraulic lock open circuit	M6702	HVAC output error ON
M3832	Auxiliary hydraulic lock overcurrent	M6703	HVAC output error OFF
M4109	Alternator too low	M6707	HVAC output open circuit
M4110	Alternator high	M6728	HVAC output failure
M4111	Alternator extremely high	M6802	HVAC relay error ON
M4304	Keyless panel no communication	M6803	HVAC relay error OFF
M4404	Auxiliary no communication	M7002	Switched power output error ON
M4510	Water in fuel sensor too high	M7003	Switched power output error OFF
M4511	Water in fuel sensor extremely high	M7007	Switched power output open circuit
M4521	Water in fuel sensor out of range high	M7028	Switched power output failure
M4522	Water in fuel sensor out of range low	M7304	Remote control no communication
M4621	5 volt sensor supply out of range high	M7316	Remote control no communication to transmitter
M4622	5 volt sensor supply out of range low	M7423	Main controller not programmed
M4721	8 volt sensor supply out of range high	M7472	Main controller needs programming
M4722	8 volt sensor supply out of range low	M7497	Main controller programmed
M4802	Front light relay error ON	M7504	Drive no communication
M4803	Front light relay error OFF	M7604	Left display panel no communication
M4902	Rear light relay error ON	M7748	Key switch multiple
M4903	Rear light relay error OFF	M7839	Hourmeter changed
M5002	Front light output error ON	M7974	Door open
M5003	Front light output error OFF	M8541	DPF automatic regeneration active
M5007	Front light output open circuit	M8542	DPF automatic regeneration active (Operate machine under load)
M5028	Front light output failure	M8551	DPF regeneration needed - inhibit active
M5102	Rear light output error ON	M8552	DPF regeneration needed - inhibit active (Operate machine under load)
M5103	Rear light output error OFF	M8553	DPF remote parked regeneration required (Remote regeneration kit required)
M5107	Rear light output open circuit	M8554	DPF service regeneration required (Contact Bobcat dealer)
M5128	Rear light output failure	M8555	DPF service required
M5202	Press to operate button error ON	M8560	DPF service regeneration active
M5221	Press to operate button out of range high	M8561	DPF service regeneration active
M5222	Press to operate button out of range low	M8562	DPF service regeneration active
M5305	Press to operate light short to battery	M8563	DPF service regeneration active
M5306	Press to operate light short to ground	M8564	DPF service regeneration active
M5405	Tilt spool lock short to battery	M8615	Engine speed derate in shutdown
M5406	Tilt spool lock short to ground	M8625	Engine speed derate unresponsive
M5407	Tilt spool lock open circuit		
M5432	Tilt spool lock overcurrent	R7404	Main controller no communication

## SEAT BAR SENSOR (CONT'D)

### Bobcat Interlock Control System (BICS™) Circuit Test (Cont'd)

Figure 60-110-15

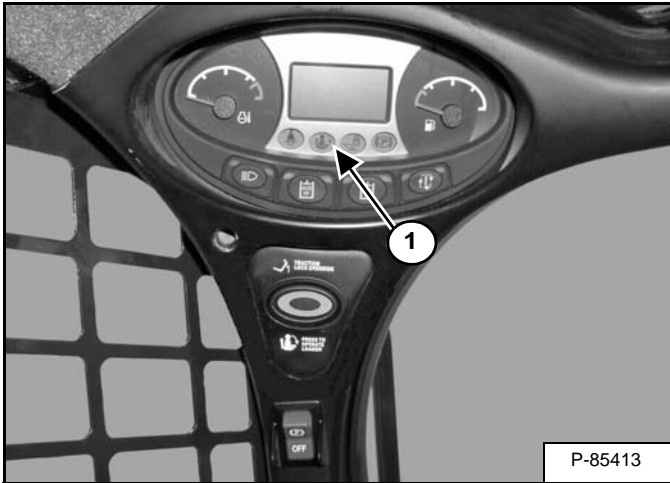

The BICS™ seat bar indicator light (Item 1) [Figure 60-110-15] should turn OFF.

Figure 60-110-16

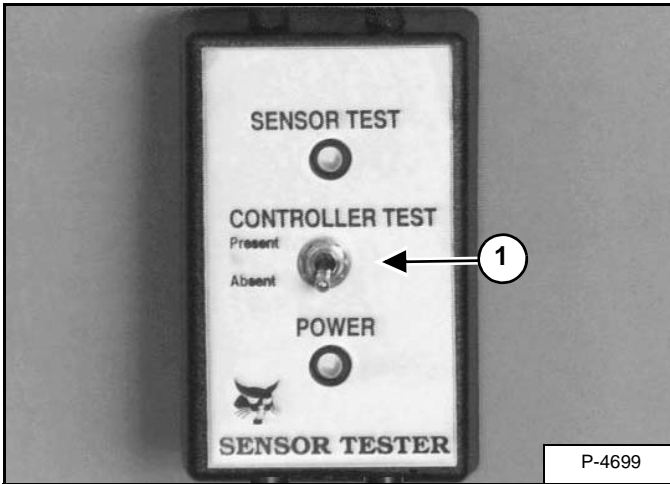

Move the toggle switch (Item 1) [Figure 60-110-16] on the sensor tester to the **Absent** position.

The Seat Bar light (Item 1) [Figure 60-110-15] should illuminate.

If the above test fails, there is a problem with the Bobcat Controller or the wiring harness.

# ELECTRICAL / HYDRAULIC CONTROLS (SCPA)

## Identification Chart

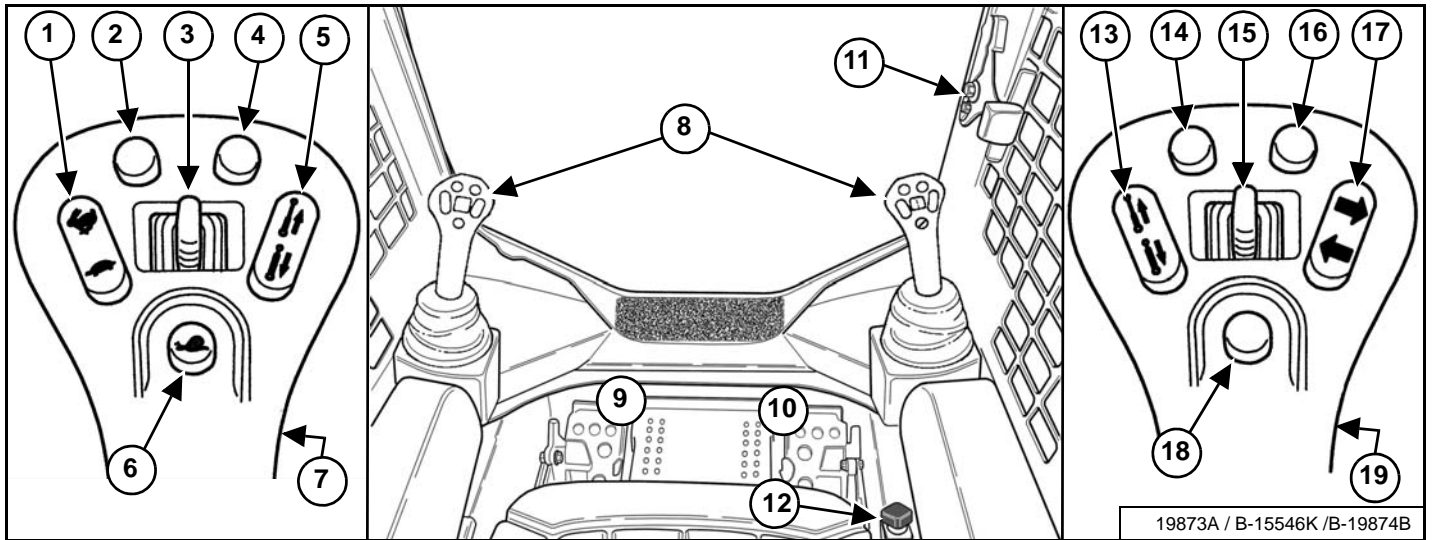

REF. NO.	DESCRIPTION
1	TWO-SPEED CONTROL (Option) Also: SPEED MANAGEMENT
2	STEERING DRIFT COMPENSATION Also: DRIVE RESPONSE
3	REAR AUXILIARY HYDRAULICS (Option) Also: ATTACHMENT FUNCTION CONTROL
4	STEERING DRIFT COMPENSATION Also: DRIVE RESPONSE
5	ATTACHMENT FUNCTION CONTROL
6	SPEED MANAGEMENT
7	FRONT HORN
8	STEERING HANDLES
9	LIFT ARM PEDAL
10	TILT PEDAL
11	ENGINE SPEED CONTROL (HAND OPERATED)
12	LIFT ARM BYPASS CONTROL
13	ATTACHMENT FUNCTION CONTROL
14	NOT USED
15	FRONT AUXILIARY HYDRAULICS
16	NOT USED
17	TURN SIGNALS (Option)
18	NOT USED
19	CONTINUOUS FLOW CONTROL FOR AUXILIARY HYDRAULICS

## CALIBRATION (CONT'D)

### Hydrostatic Pump Calibration (SJC)

Figure 60-150-6

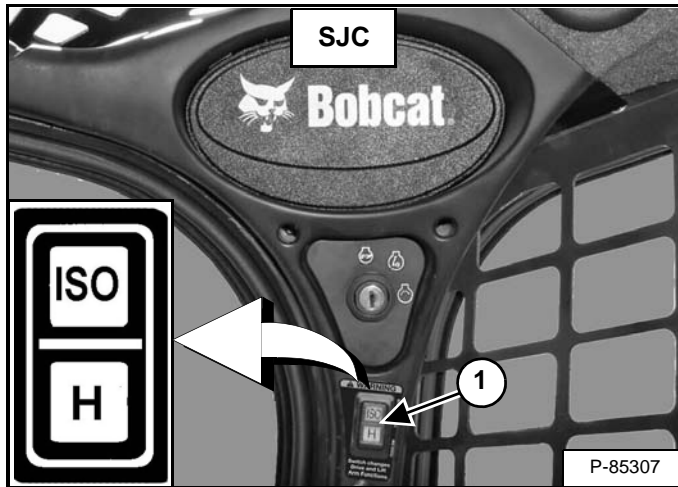

The loader Control Pattern Switch (Item 1) [Figure 60-150-6] will start flashing and will continue to flash until the calibration procedure is completed.

Figure 60-150-7



At the left panel, press the PRESS TO OPERATE Button (Item 1) [Figure 60-150-7] while holding the right joystick in position.

Release the joystick.

**NOTE:** During the calibration cycle, the system will beep. Once the calibration is complete, code W3224 (Calibration Successful) or W3225 (Calibration Failure) will be generated.

The ACS controller will cycle the actuators.

The lift and tilt calibration is complete.

## **WARNING**

Put jackstands under the front axles and rear corners of the frame before running the engine for service. Failure to use jackstands can allow the machine to fall or move and cause injury or death.

W-2017-0286

**NOTE:** If the speed sensors are removed or disconnected the drive calibration procedure must be performed.

**NOTE:** If swash plate sensors have been removed and reinstalled, replaced or adjusted the drive calibration procedure must be performed.

Place the loader on jack stands. (See Procedure on Page 10-10-1.)

Operator must be in the seat and the seat bar down.

Figure 60-150-8

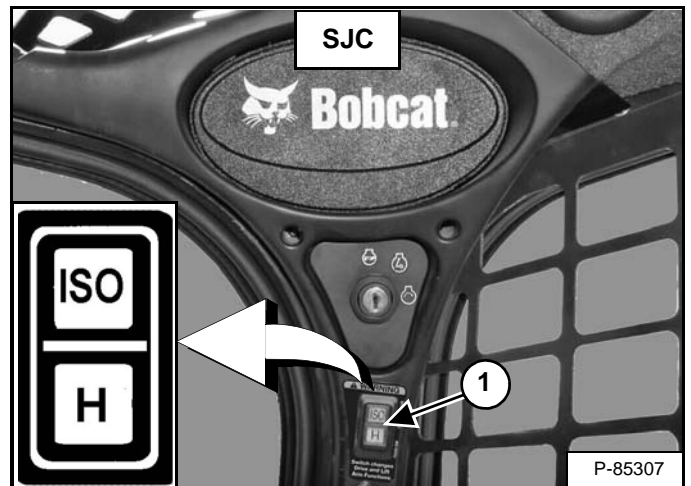

Close the cab door (If loader is so equipped).

Place the loader Control Pattern Switch (Item 1) [Figure 60-150-8] in the ISO position.

Verify that the parking brake switch is in the OFF position.

## STEERING DRIFT COMPENSATION (OPERATOR MODE)

### Description

Steering Drift Compensation can be used to reduce steering drift to maintain a desired travel path in forward and reverse directions.

Examples of applications where this feature can be used:

- To compensate for normal variations such as tire inflation pressure, track tension, tire wear and track wear.
- Using side shift attachments such as trenchers, planers, and silt fence installers.
- Driving on uneven terrain such as crowned road surfaces.

Figure 60-160-1

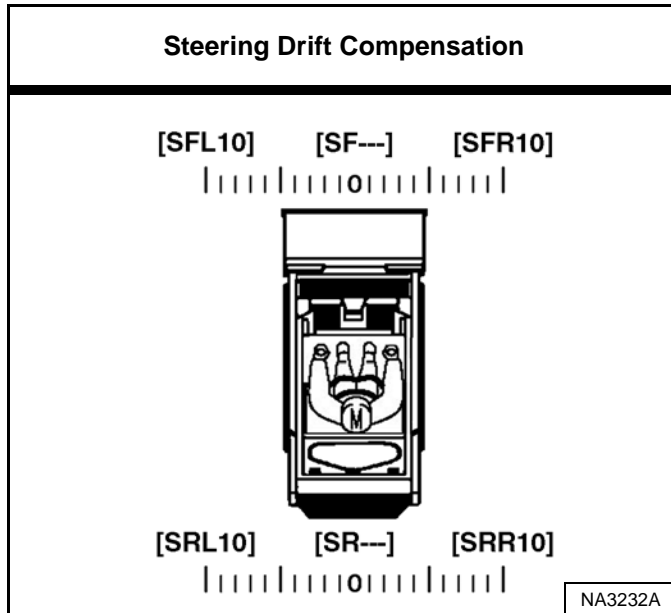

Steering drift compensation contains a total of 21 settings. Steering drift compensation can be set to any point from neutral to [SFL10] or [SRL10] left, and from neutral to [SFR10] or [SRR10] right. [SF---] [SR---] is displayed when set for neutral [Figure 60-160-1].

### Operation

**NOTE: Changes CANNOT be performed until the seat bar is lowered, the engine is started and the PRESS TO OPERATE LOADER button is pressed to activate the BICS™.**

Perform PRE-STARTING PROCEDURE and STARTING THE ENGINE procedures:

1. Fasten seat belt.
2. Lower seat bar.
3. Put controls in neutral position.
4. Start the engine.
5. Press the PRESS TO OPERATE LOADER button.
6. Current drive response setting is displayed briefly in the data display.

**NOTE: (SJC) Raising the seat bar or changing control mode (ISO / H) will cause the machine to disengage from steering drift compensation. The last displayed setting will remain in effect until the machine is turned OFF.**

## PASSWORD SETUP (KEYLESS START PANEL)

### Password Description

#### Master Password:

A permanent, randomly selected password set at the factory which cannot be changed. This password is used for service by the Bobcat dealer if the owner password is not known; or to change the owner password.

#### Owner Password:

Allows for full use of the loader. It must be used to change the owner password.

### Changing The Owner Password

Turn the key switch to the RUN position to turn on the loaders electrical system.

Enter the five digit owner password using the number keys (1 through 0) if locked.

Figure 60-191-1



Press and hold the lock (Item 1) and unlock (Item 2) [Figure 60-191-1] keys for two seconds.

The lock key red light will flash and the left panel display screen will show [ENTER].

Enter a new five digit password using the number keys (1 through 0). An asterisk will show in the left panel display screen for each key press.

The left panel display screen will show [AGAIN].

Enter the new five digit owner password again.

The lock key red light will become solid.

### Password Lockout Feature

This feature allows the owner to unlock the password feature so that a password does not need to be used every time the engine is started.

Turn the key switch to the RUN position to turn on the loaders electrical system.

Enter the five digit owner password using the number keys (1 through 0).

Figure 60-191-2

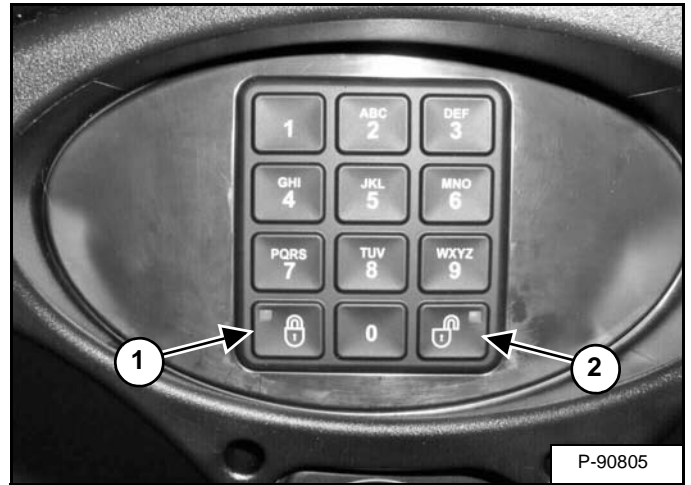

Press the unlock key (Item 2) [Figure 60-191-2].

The left panel display screen will show [CODE].

Enter the five digit owner password using the number keys (1 through 0). The unlock key green light will flash, then become solid.

The loader can now be started without using a password.

**NOTE: Use the following procedure to reset the machine lock so that the loader requires a password to start the engine.**

Turn the key switch to the RUN position to turn on the loaders electrical system.

Press the lock key (Item 1) [Figure 60-191-2].

The lock key red light will flash and the left panel display screen will show [CODE].

Enter the five digit owner password using the number keys (1 through 0). The unlock key green light will flash, then the lock key red light will become solid.

You must now enter the password every time to start the loader.

## FRONT HORN

### Removal And Installation

**NOTE: Two different style horns are used.**

Remove left side lower panel. (See Removing And Installing on Page 50-150-1)

**Figure 60-220-1**

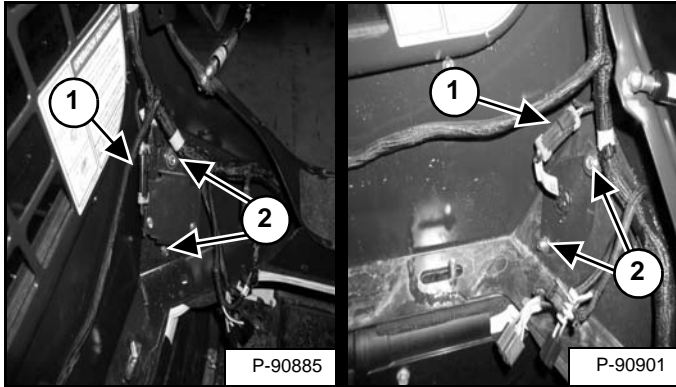

**Figure 60-220-2**

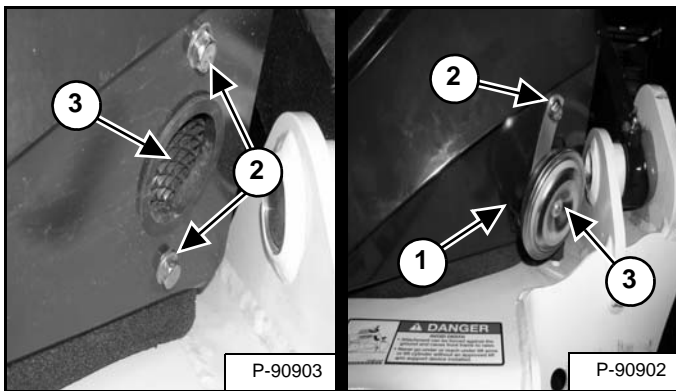

Disconnect the wire harness (Item 1) [Figure 60-220-1] and [Figure 60-220-2] from the front horn.

Remove the two bolts and nuts (Item 2) [Figure 60-220-1] and [Figure 60-220-2].

Remove the front horn and bracket from the loader (Item 3) [Figure 60-220-2].

**Figure 60-220-3**

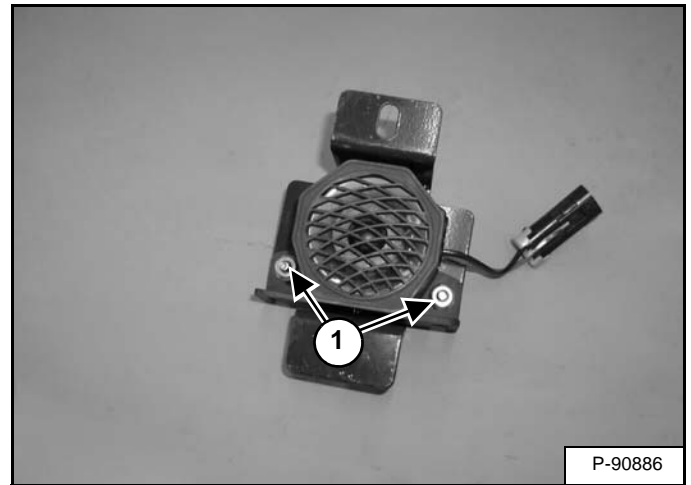

Remove the two bolts and nuts (Item 1) [Figure 60-220-3].

Remove front horn from the bracket.

## ENGINE INFORMATION (CONT'D)

### Torque Values

Thread Size (Dia. x Pitch)	Material		
	Head Mark 4	Head Mark 7	Head Mark 10
M5 x 0.8		4 - 5 N•m (3 - 4 ft-lb)	
M6 x 1.0		8 - 9 N•m (6 - 7 ft-lb)	8 - 12 N•m (6 - 9 ft-lb)
M8 x 1.25	8 - 12 N•m (6 - 9 ft-lb)	15 - 22 N•m (11 - 16 ft-lb)	24 - 34 N•m (18 - 25 ft-lb)
M10 x 1.25	18 - 24 N•m (13 - 18 ft-lb)	30 - 41 N•m (22 - 30 ft-lb)	49 - 68 N•m (36 - 50 ft-lb)
M12 x 1.25	30 - 41 N•m (22 - 30 ft-lb)	54 - 73 N•m (40 - 54 ft-lb)	94 - 118 N•m (69 - 87 ft-lb)
M14 x 1.5	49 - 68 N•m (36 - 50 ft-lb)	79 - 108 N•m (58 - 80 ft-lb)	157 - 186 N•m (116 - 137 ft-lb)

### Troubleshooting

The following troubleshooting chart is provided for assistance in locating and correcting problems which are most common. Many of the recommended procedures must be done by authorized Bobcat Service Personnel only.

PROBLEM	CAUSE
Slow cranking speed.	1, 2, 3, 54
Engine will not start.	2, 5, 6, 7, 8, 9, 10, 11, 12, 13, 14, 15, 16, 19, 27, 28, 29
Difficult to start.	1, 2, 5, 7, 8, 9, 10, 11, 12, 13, 15, 16, 17, 18, 19, 20, 25, 27, 28, 29, 54
No power for engine.	8, 9, 10, 11, 12, 13, 15, 16, 17, 18, 20, 21, 22, 23, 27, 28, 29
Engine is misfiring.	8, 9, 11, 12, 13, 15, 16, 17, 21, 22, 24, 25, 26, 28
Too much fuel consumption.	10, 12, 13, 15, 16, 17, 19, 20, 21, 23, 24, 25, 27, 28, 29
Black exhaust.	10, 12, 13, 15, 16, 17, 19, 20, 21, 23, 24, 25, 27, 28, 29
Blue / white exhaust.	4, 10, 15, 16, 17, 21, 23, 27, 29, 30, 50
Low oil pressure.	4, 31, 32, 33, 34, 35, 37, 38, 39, 52
Engine knocking.	13, 15, 16, 19, 22, 24, 25, 27, 29, 31, 40, 41, 53
Engine running rough.	7, 8, 9, 10, 11, 12, 13, 17, 18, 22, 24, 25, 26, 29, 40, 53
Vibration.	12, 13, 17, 21, 22, 25, 26, 29, 40, 42, 43
High oil pressure warning.	4, 33, 36
Overheating.	10, 12, 13, 15, 16, 20, 21, 40, 44, 45, 46, 47, 48, 51
Too much crankcase pressure.	22, 27, 29, 30, 40, 49
Poor compression.	10, 16, 21, 24, 25, 27, 28, 29, 30, 41, 53
Start and stop.	9, 10, 11

## ENGINE SPEED CONTROL (HAND)

### Removal And Installation

Figure 70-20-1

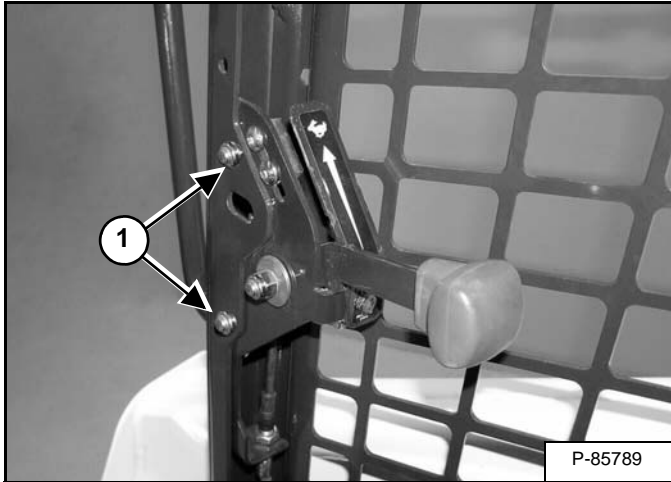

Remove the two mounting bolts (Item 1) [Figure 70-20-1].

Figure 70-20-2

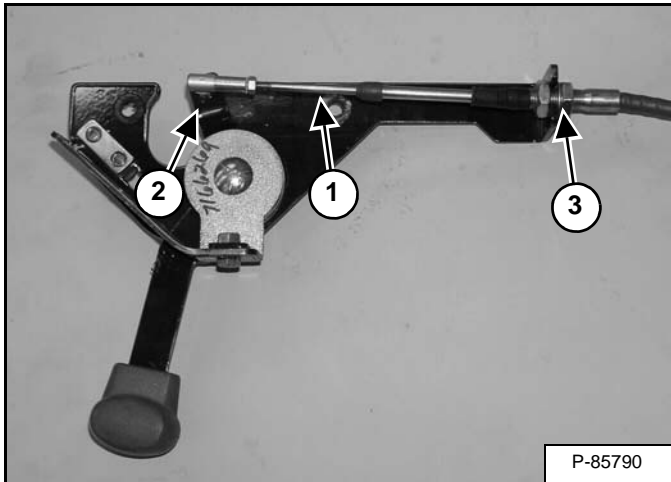

The speed control cable (Item 1) is connected to the speed control handle (Item 2) by a ball and socket end [Figure 70-20-2].

Disconnect the speed control cable (Item 1) from the speed control handle (Item 2) [Figure 70-20-2].

Loosen the jam nut (Item 3) [Figure 70-20-2] from the speed control cable.

Remove the cable from the speed control handle.

## Disassembly And Assembly

Figure 70-20-3

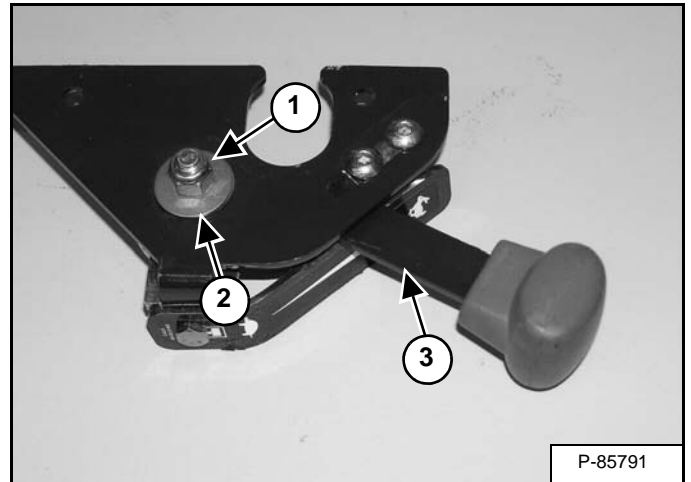

Remove the nut (Item 1) and remove the two conical washers (Item 2) [Figure 70-20-3].

Remove the handle (Item 3) [Figure 70-20-3].

**Installation:** Install the two conical washers with the concave surfaces facing each other (Item 2) [Figure 70-20-3].

**Installation:** Tighten the nut (Item 1) [Figure 70-20-3] until the speed control lever moves backward and forward at a comfortable tension.

Figure 70-20-4

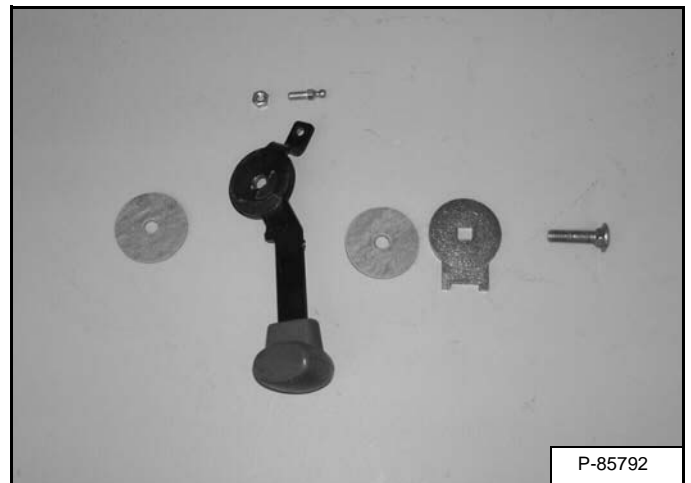

Inspect and replace any damaged parts [Figure 70-20-4].

## ENGINE COOLING SYSTEM (EARLIER MODELS)

### Radiator Removal And Installation

Stop the engine and open the rear door.

Remove the rear grille and side panels. (See Removing on Page 50-60-1.)

Remove the oil cooler. (See Removal And Installation on Page 20-90-1.)

**! WARNING**

#### AVOID BURNS

Do not remove radiator cap when the engine is hot. You can be seriously burned.

W-2070-1203

Figure 70-50-1

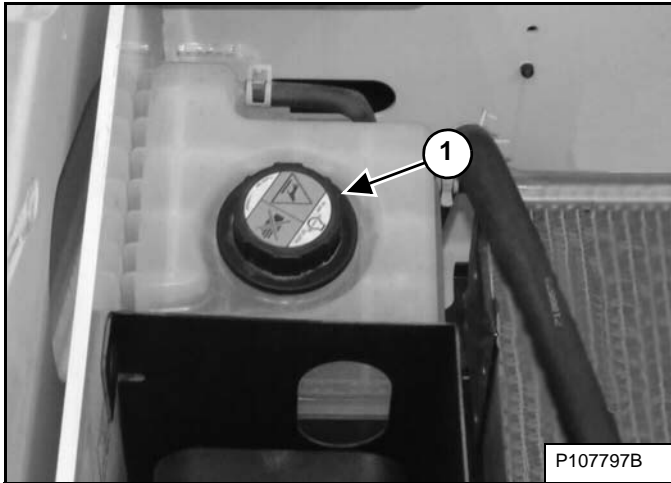

Loosen the coolant fill cap (Item 1) [Figure 70-50-1] from the coolant tank.

Figure 70-50-2

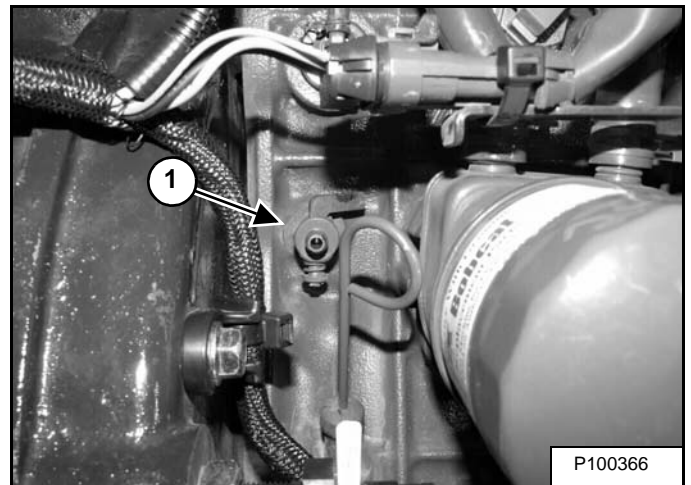

Attach a hose to the coolant drain petcock (Item 1) [Figure 70-50-2] located to the left of the oil filter assembly. Open the petcock and drain the coolant into a container. Close the petcock and remove the hose.

Figure 70-50-3

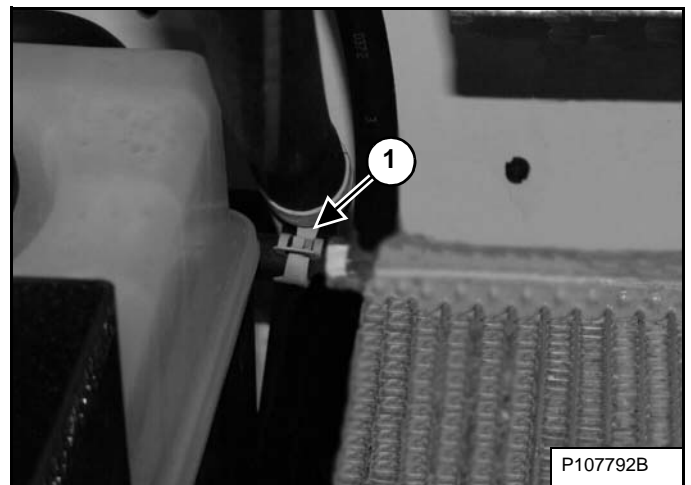

Disconnect and plug the radiator air bleed hose (Item 1) [Figure 70-50-3].

## ENGINE COOLING SYSTEM (LATER MODELS) (CONT'D)

### Hydraulic Fan Description

The proportional relief valve meters the flow through the fan motor. The valve receives signals from the controller which gathers information from both the engine and hydraulic temperature sensors.

The hydraulic fan is used to cool the engine and hydraulic / hydrostatic systems. The hydraulic fan consists of a fan and hydraulic motor that is controlled by a proportional relief valve.

**NOTE: The proportional relief valve is factory set and can not be adjusted accurately in the field due to the adjustment being tamper proof.**

The fan speed is determined by the engine coolant temperature and the hydraulic fluid temperature. Depending on these temperatures the fan speed (rpms) can range from 0 - 4000 rpms.

### Hydraulic Reversing Fan Description

This machine may be equipped with a Reversing Fan.

The function of the reversing fan is to clear dust and debris from the rear grille. This is accomplished by software control of a reversing valve in the fan motor assembly.

A reversing cycle consists of the following steps and takes about 16 seconds total.

1. Flow to the rotating group is ramped down.
2. Reversing valve shifts, switching inlet and outlet ports.
3. Flow to the rotating group is ramped up, spinning the fan in reverse direction. Full fan speed is held for about 3 seconds.
4. Flow to the rotating group is ramped down.
5. Reversing valve shifts back to neutral.
6. Flow is ramped up and normal cooling is restored. Reversing frequency varies from 30 to 5 minute intervals depending on fluid temperature.

**NOTE: To protect vital systems, the fan will not reverse when fluid temperatures are low (below 60°F). To prevent overheating, the fan will not reverse when fluid temperatures are very high (engine coolant over 210°F, or hydraulic fluid over 226°F in auto mode or 230°F in manual mode).**

### Lower Fan Duct Removal And Installation

Raise the operator cab. (See Raising on Page 10-30-2.)

**Figure 70-51-9**

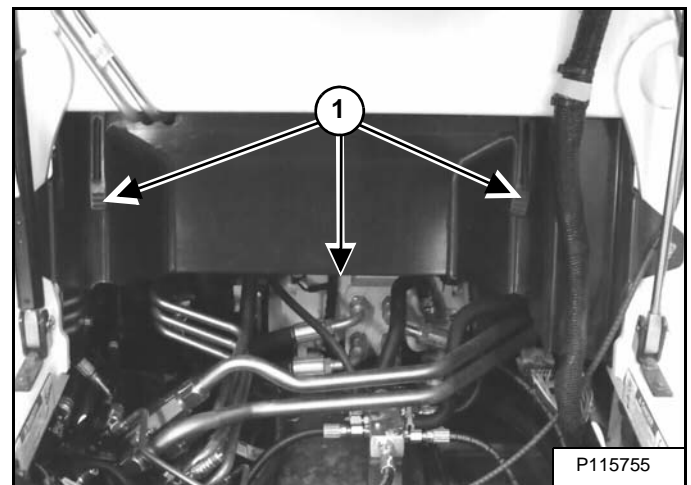

Unhook the rubber straps (Item 1) [Figure 70-51-9] and remove lower fan duct.

## ENGINE COOLING SYSTEM (LATER MODELS) (CONT'D)

### Hydraulic Fan Motor Disassembly And Assembly (Cont'd)

All Models (Cont'd)

Figure 70-51-52

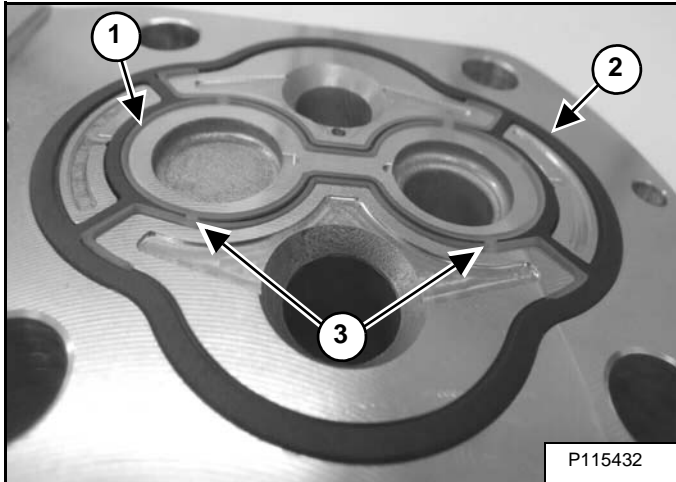

Press a new yellow plastic seal (Item 1) firmly onto the black rubber seal (Item 2) [Figure 70-51-52].

The ejector pads (Item 3) [Figure 70-51-52] on the yellow plastic seal will be facing up.

**NOTE:** Verify that both seals are flush with the surface of the housing.

Figure 70-51-53

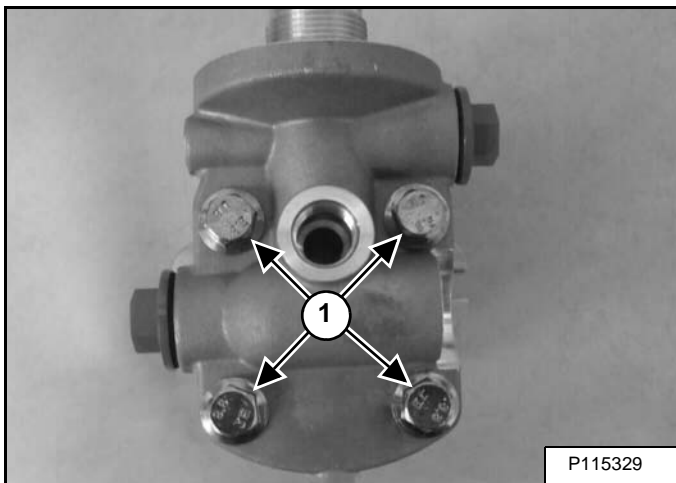

Assemble the fan motor and the filter adapter. Install the four bolts (Item 1) [Figure 70-51-53].

**Installation:** Tighten the four bolts (Item 1) [Figure 70-51-53] to 37 - 45 N•m (27 - 33 ft-lb) torque.

## Blower Housing Removal And Installation

# IMPORTANT

When repairing hydrostatic and hydraulic systems, clean the work area before disassembly and keep all parts clean. Always use caps and plugs on hoses, tubelines and ports to keep dirt out. Dirt can quickly damage the system.

I-2003-0888

Remove the air conditioning condenser if equipped. (See Removal And Installation on Page 80-61-1.)

Remove the radiator / oil cooler. (See Radiator / Oil Cooler Removal And Installation on Page 70-51-1.)

Figure 70-51-54

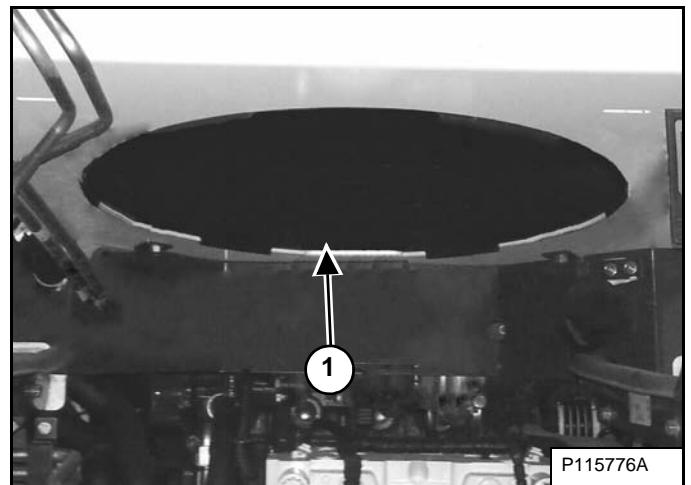

Push the blower housing (Item 1) [Figure 70-51-54] up and remove the housing from the loader.

**NOTE:** Hydraulic fan assembly removed for photo clarity.

## FUEL SYSTEM (CONT'D)

### Fuel Injection Pump Assembly Removal (Cont'd)

Figure 70-70-6

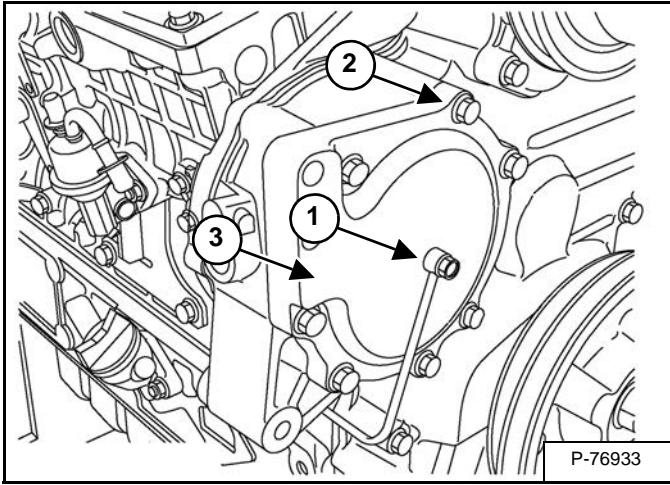

Remove the lubrication tubeline (Item 1), the timer gear cover mounting bolts (Item 2) and the timer gear cover (Item 3) [Figure 70-70-6].

Figure 70-70-7

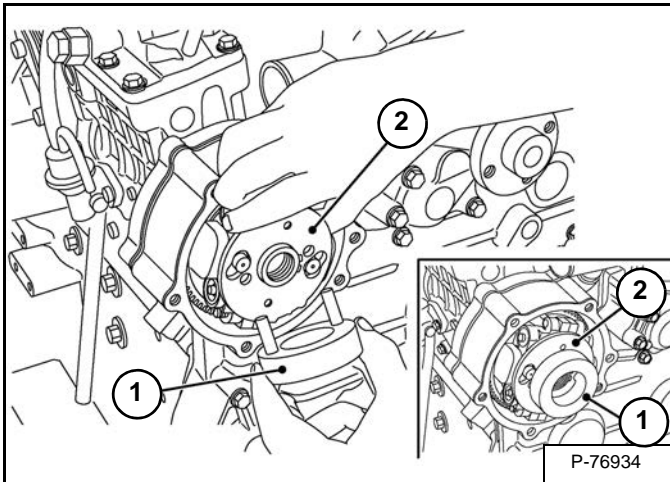

Install the 0° Restoring Jig (MEL1656) (Item 1) on to the timer gear (Item 2) [Figure 70-70-7].

Figure 70-70-8

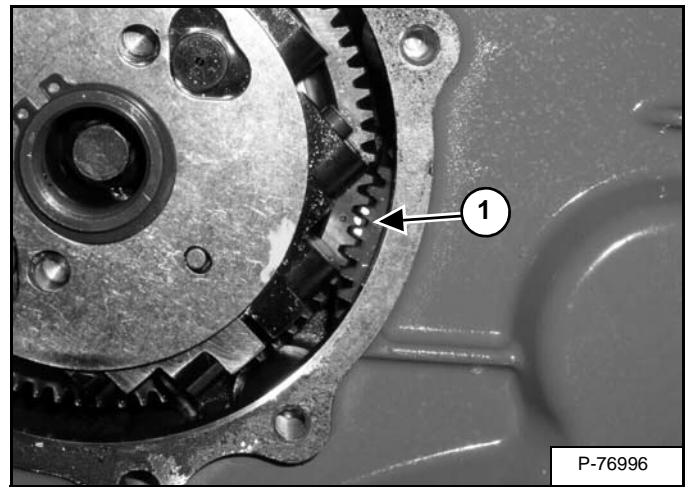

With the number four piston at T.D.C. compression stroke place a mark on the timer gear and the idler gear where the teeth engage (Item 1) [Figure 70-70-8].

Pin the flywheel so that the engine does not turn.

Figure 70-70-9

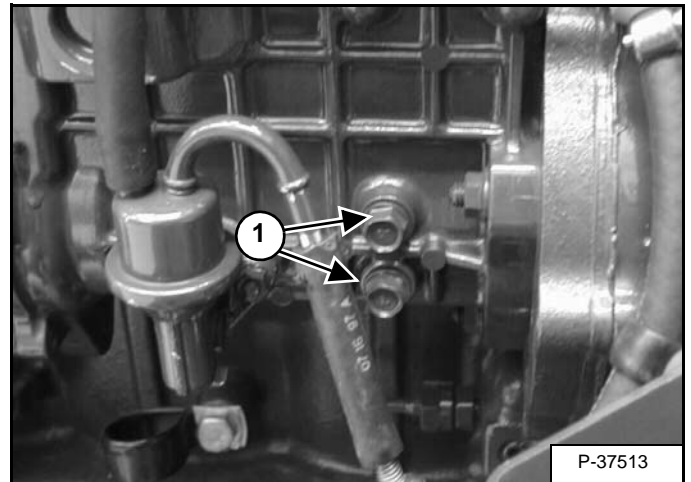

Remove the two flange bolts (Item 1) [Figure 70-70-9] from the injection pump assembly.

## FUEL SYSTEM (CONT'D)

### Fuel Injection Pump Removal (Cont'd)

Figure 70-70-47

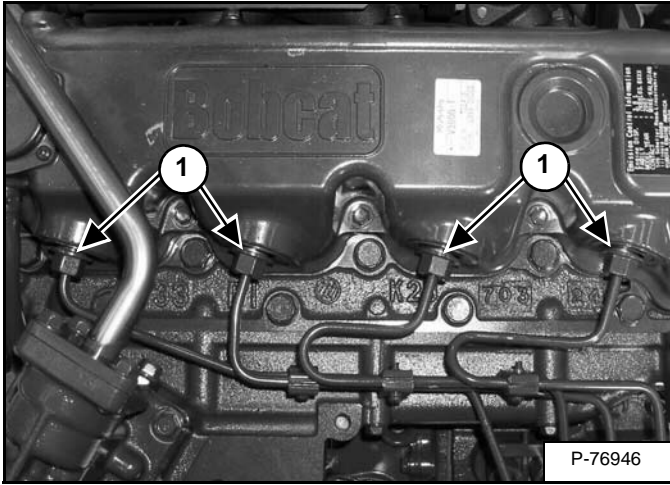

Disconnect the four injection lines (Item 1) [Figure 70-70-47] at the injection nozzle assemblies.

Remove the injection lines from the loader.

Figure 70-70-48

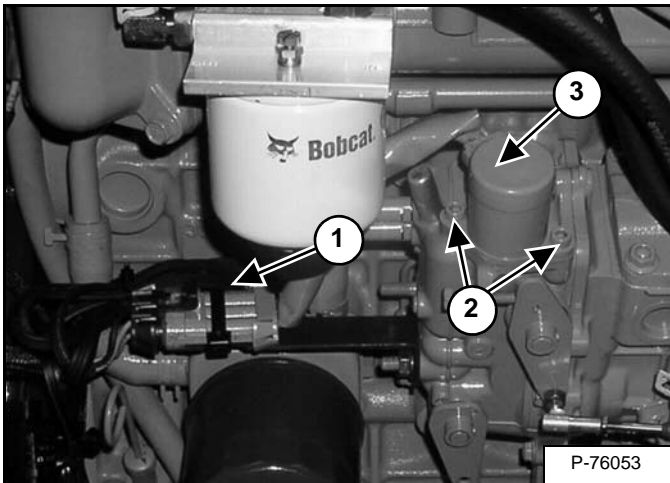

Disconnect the electrical connector (Item 1) from the fuel stop solenoid. Then remove the two mounting bolts (Item 2) [Figure 70-70-48] from the fuel stop solenoid.

Remove the solenoid (Item 3) [Figure 70-70-48] from the injection pump.

Figure 70-70-49

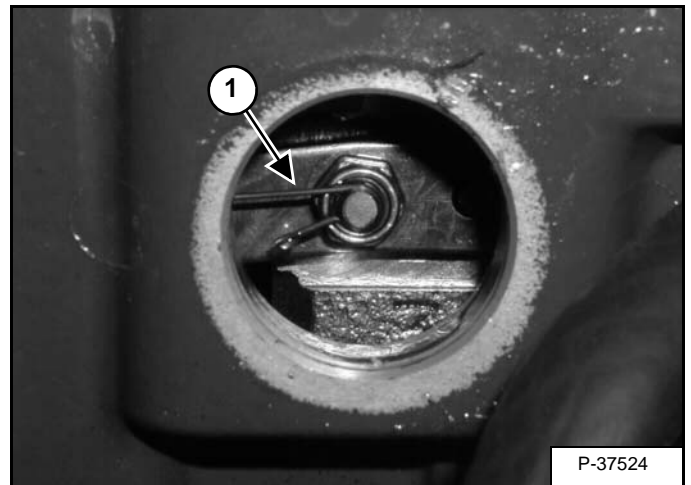

Disconnect the starter spring hook (Item 1) [Figure 70-70-49].

**NOTE:** Be careful to not deform the starter spring.

Figure 70-70-50

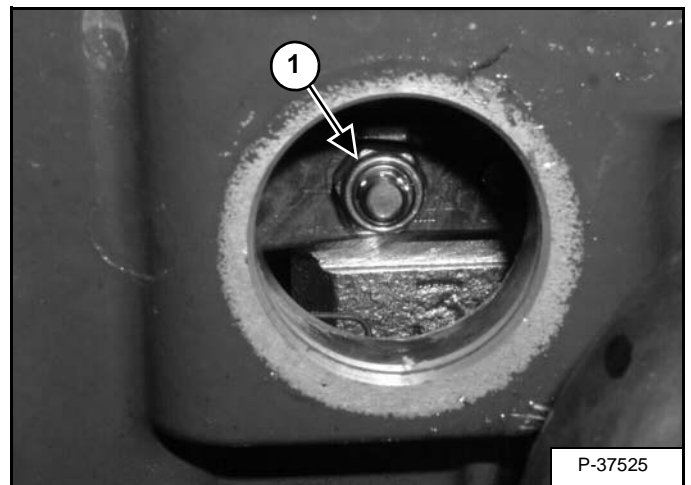

Remove the governor connecting rod nut (Item 1) [Figure 70-70-50].

**NOTE:** Be careful not to drop the governor connecting rod nut.

**Installation:** Tighten the governor connecting rod nut to 2,8 - 4,0 N•m (2.1 - 2.9 ft-lb) torque.

## CYLINDER HEAD

### Intake Air Heater - Testing

Figure 70-80-1

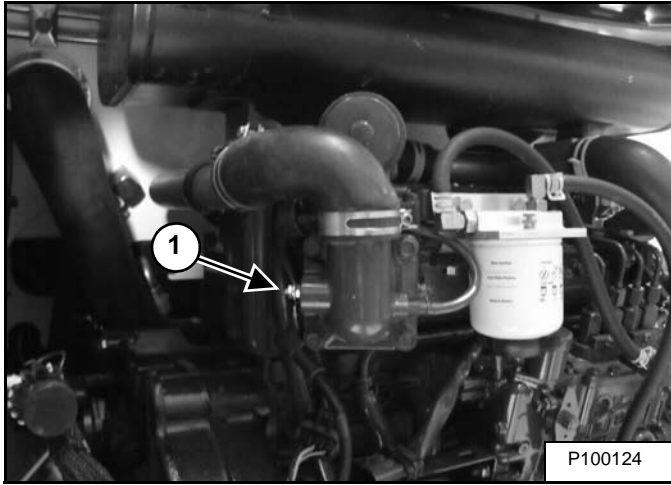

Disconnect the electrical wire (Item 1) [Figure 70-80-1] from the air intake heater.

Figure 70-80-2

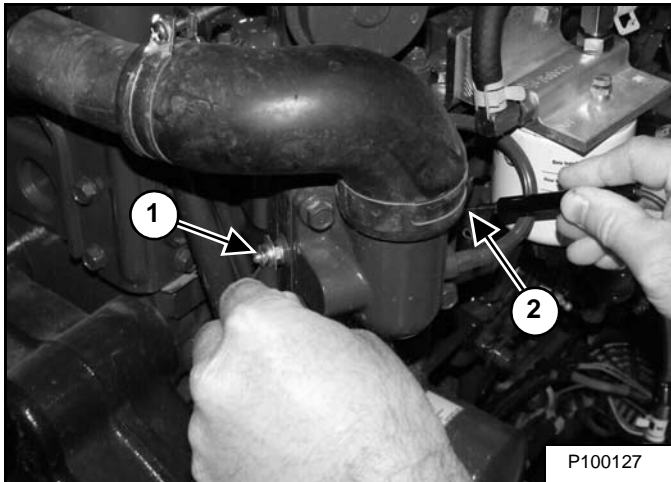

Measure the resistance between + terminal (Item 1) and intake air heater body (Item 2) [Figure 70-80-2].

If the resistance is open, the intake air heater is faulty.

Intake air heater resistance	Factory spec.	Approx. 0.3 ohm (At cold occasion)
------------------------------	---------------	------------------------------------

### Intake Air Heater Removal And Installation

Figure 70-80-3

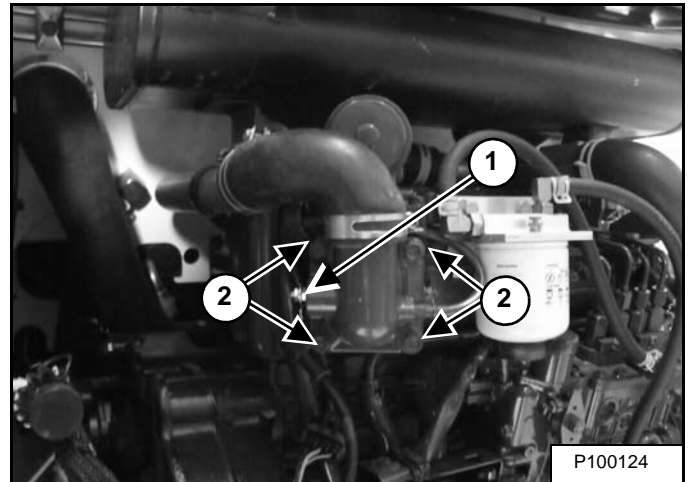

Disconnect the electrical wire from the intake heater lead (Item 1) [Figure 70-80-3].

Remove the four mount bolts (Item 2) [Figure 70-80-3] from the intake air heater housing.

**Installation:** Tighten the bolts to 24 - 28 N•m (17 - 20 ft-lb) torque.

Figure 70-80-4

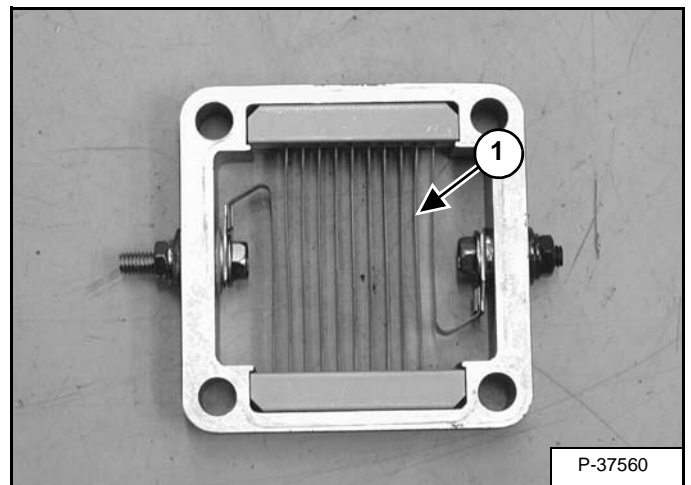

**NOTE:** When installing the intake air heater in the housing, install the intake air heater so the heater lines (Item 1) [Figure 70-80-4] are vertical, to prevent a short-circuit in the system.

## CYLINDER HEAD (CONT'D)

### Valve Spring

Figure 70-80-38

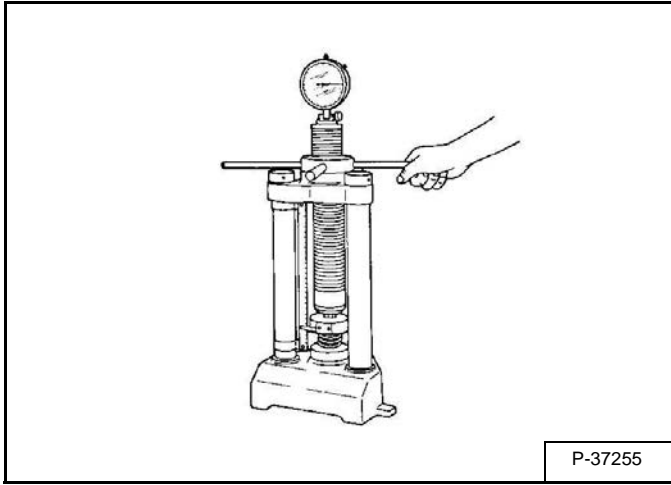

P-37255

Place the valve spring on a tester and compress it to the same length it is actually compressed in the engine [Figure 70-80-38].

Read the compression load on the gauge.

If the measurement is less than the allowable limit, replace it.

Setting load / setting length	Factory spec.	Intake valve	63,5 N / 31,5 mm (14.3 lb / 1.24 in)
		Exhaust valve	63,5 N / 31,5 mm (14.3 lb / 1.24 in)
	Allowable limit	Intake valve	45,9 N / 31,5 mm (10.3 lb / 1.24 in)
		Exhaust valve	45,9 N / 31,5 mm (10.3 lb / 1.24 in)

Figure 70-80-39

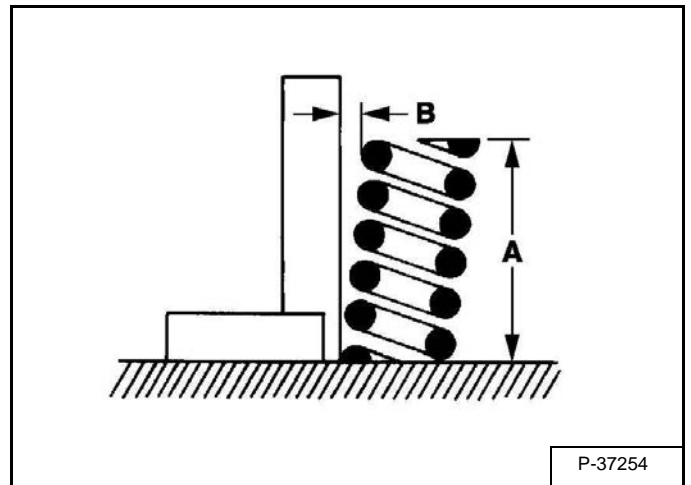

P-37254

Measure the free length (A) with vernier calipers [Figure 70-80-39]. If the measurement is less than the allowable limit, replace it.

Put the spring on a surface plate, place a square on the side of the spring, and check to see if the entire side is contact with the square. Rotate the spring and measure the maximum (B) [Figure 70-80-39]. If the measurement exceeds the allowable limit, replace.

Check the entire surface of the spring for scratches. Replace spring, if any are found.

Free length (A)	Factory spec.	Intake valve	35,1 - 35,6 mm (1.39 - 1.40 in)
		Exhaust valve	35,1 - 35,6 mm (1.39 - 1.40 in)
	Allowable limit	Intake valve	34,6 mm (1.36 in)
		Exhaust valve	34,6 mm (1.36 in)
Tilt (B)	Allowable limit	1,0 mm (0.039 in)	

## CRANKSHAFT AND PISTONS (CONT'D)

### Crankshaft And Bearings Removal

Remove the flywheel housing. (See Housing Removal And Installation on Page 70-120-2.)

Remove the oil pan. (See Oil Pan Removal And Installation on Page 70-60-1.)

Figure 70-90-22

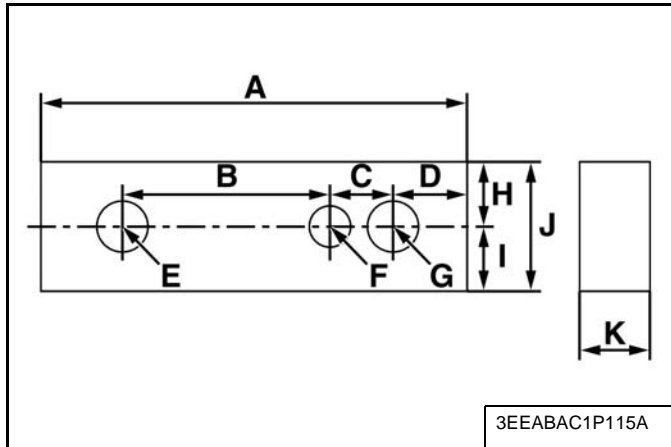

Application: Use for aligning the crankcase 1 and 2.

A	115 mm (4.53 in)
B	56 mm (2.2 in)
C	17 mm (0.67 in)
D	20 mm (0.79 in)
E	14 mm dia. (0.55 in dia.)
F	11 mm dia. (0.43 in dia.)
G	14 mm dia. (0.55 in dia.)
H	17,5 mm (0.6890 in)
I	17,5 mm (0.6890 in)
J	35 mm (1.4 in)
K	19 mm (0.75 in)

Figure 70-90-23

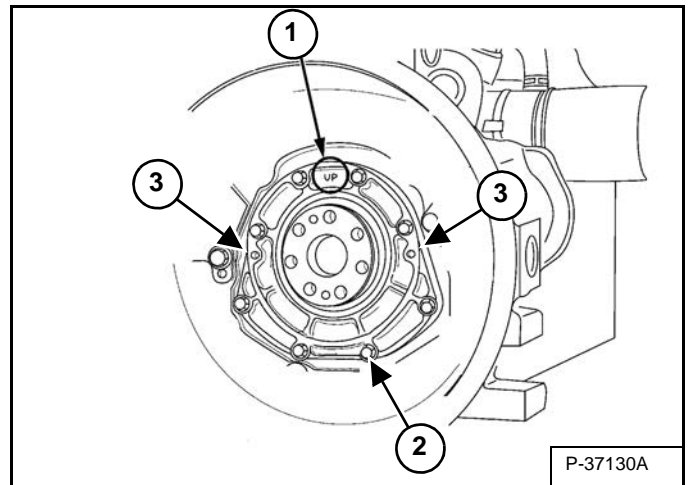

**NOTE:** Before disassembling, check the end play of crankshaft. Also check it during reassembly. Check the crankshaft end play. (See Crankshaft And Bearings - Servicing on Page 70-90-13.)

Remove the eight bearing case cover mounting bolts (Item 2) [Figure 70-90-23].

Install the two bolts removed earlier into the bolt hole (Item 3) [Figure 70-90-23] of bearing case cover to remove it.

**NOTE:** Install the bearing case cover / oil seal assembly with the casting mark labeled "UP" (Item 1) [Figure 70-90-23] at the top.

## CAMSHAFT AND TIMING GEARS (CONT'D)

### Camshaft - Servicing

#### End Play

**Figure 70-100-8**

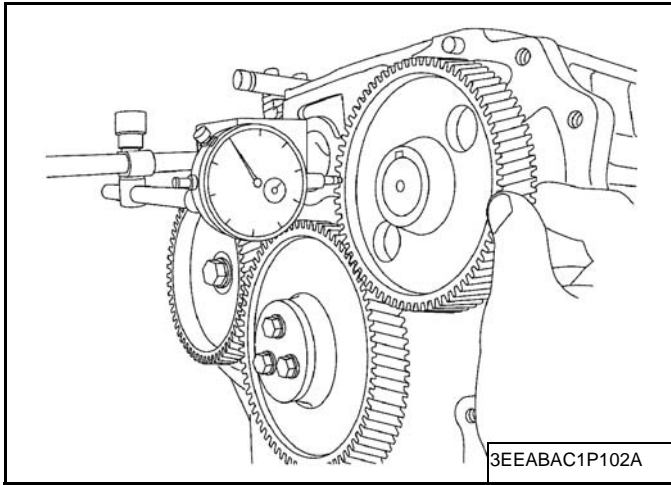

Set a dial indicator with its tip on the camshaft **[Figure 70-100-8]**.

Measure the end play by moving the camshaft gear to the front and rear.

If the measurement exceeds the allowable limit, replace the camshaft stopper.

End play	Factory spec.	0,070 - 0,22 mm (0.0028 - 0.0086 in)
	Allowable limit	0,030 mm (0.012 in)

#### Alignment

**Figure 70-100-9**

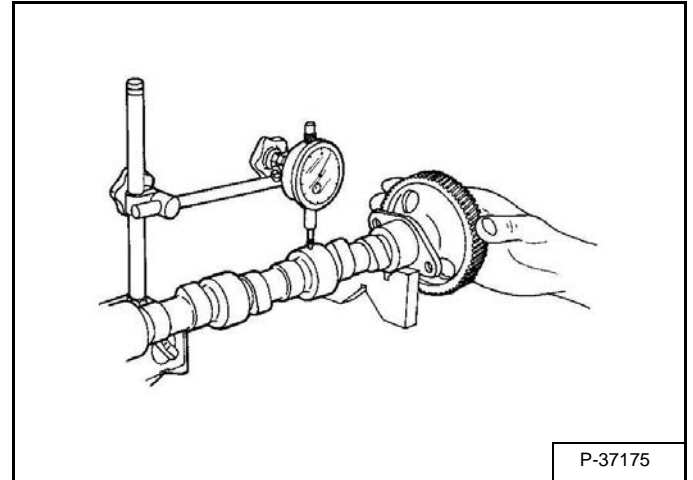

Support the camshaft with V block on the surface plate and set a dial indicator with its tip on the intermediate journal at right angle **[Figure 70-100-9]**.

Rotate the camshaft on the V blocks and get the misalignment (half of the measurement).

If the misalignment exceeds the allowable limit, replace the camshaft.

Camshaft alignment	Allowable limit	0,01 mm (0.0004 in)
--------------------	-----------------	------------------------

## EXHAUST GAS RECIRCULATION (EGR) SYSTEM (CONT'D)

### Testing (Cont'd)

Figure 70-130-3

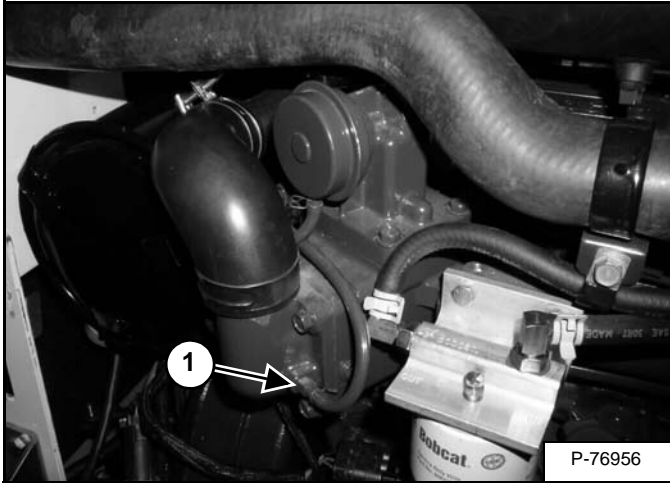

Disconnect the boost hose (Item 1) [Figure 70-130-3] from the intake.

Figure 70-130-4

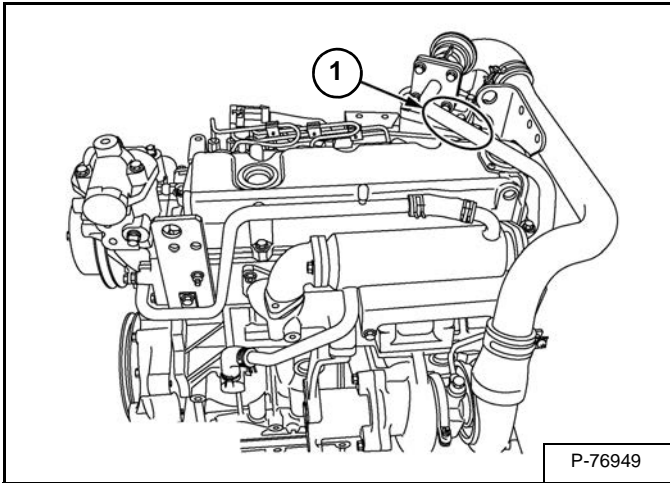

Measure the surface temperature of the EGR pipe (Item 1) [Figure 70-130-4] with an Infrared Thermometer.

If the surface temperature of the EGR pipe declines, the thermo valve has failed.

If the surface temperature of the EGR pipe stays above 100°C (212°F), the EGR valve has failed.

### Hot Engine Coolant Temperature Test

Verify the engine temperature is above 70°C (158°F), if the engine temperature is below 70°C (158°F) run the engine to bring the temperature above 70°C (158°F) then continue with the Hot Engine Coolant Temperature Test.

Figure 70-130-5

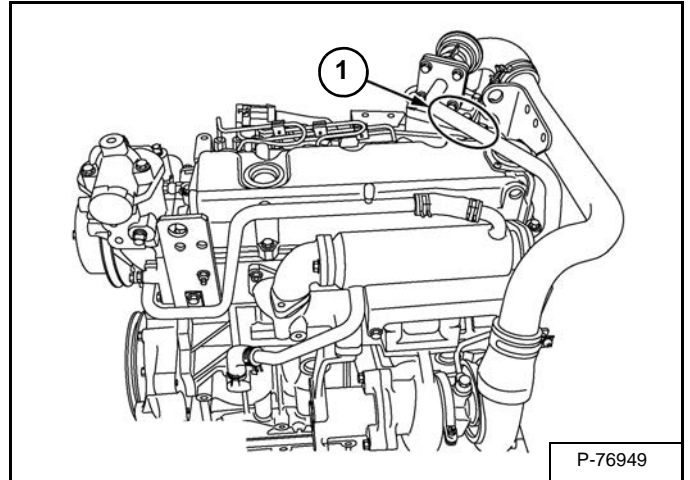

Measure the surface temperature of the EGR pipe (Item 1) [Figure 70-130-5] with an Infrared Thermometer.

With the engine coolant temperature above 70°C (158°F) and the surface temperature of the EGR pipe 100°C (212°F) or above, the EGR system is OK.

If the surface temperature of the EGR pipe is 50°C (122°F) or below continue this Hot Engine Coolant Temperature Test.

Figure 70-130-6

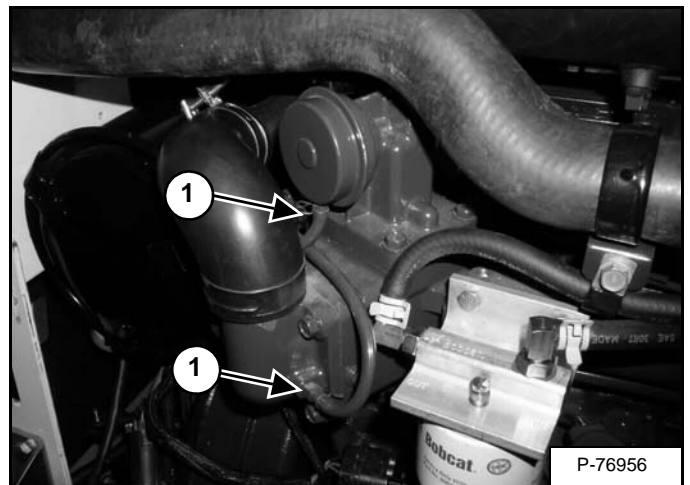

Disconnect the two hoses (Item 1) [Figure 70-130-6].

## AIR CONDITIONING SYSTEM FLOW (CONT'D)

### Safety Equipment

Figure 80-10-14

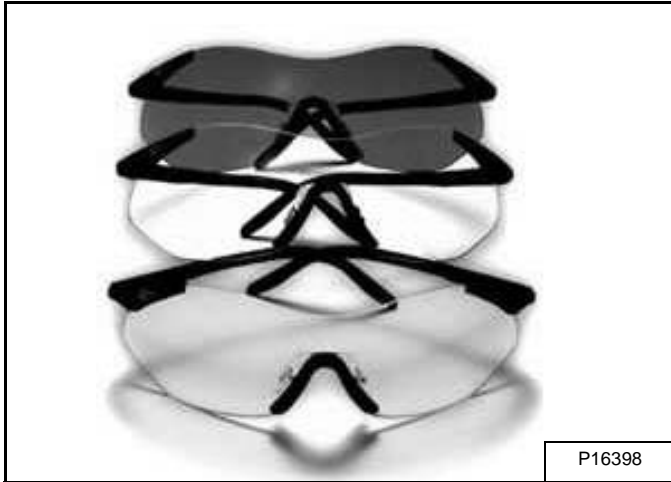

Figure 80-10-15



In servicing A/C and heater systems you will be exposed to high pressures, temperatures and several chemical hazards. Moving belts and pulleys are normal shop hazards.

In addition to exercising caution in your work, **DO WEAR SAFETY GLASSES OR A FACE SHIELD [Figure 80-10-14]** when you are using R-134a or a leak detector, adjusting service valves or the manifold gage set connectors. Safety glasses or a transparent face shield are practical safety items and one or the other is absolutely required.

## **WARNING**

In the event of a leak, wear safety goggles. Escaping refrigerant can cause severe injuries to eyes. In contact with a flame, R-134a refrigerant gives a toxic gas.

W-2371-0611

R-134a inside a canister or in an A/C system is a liquid under pressure. When it escapes or releases into the air, **ITS TEMPERATURE DROPS TO -6°C (21.6°F) "INSTANTLY"**. If it spills on your skin or in your eyes you should flood the area with cool water and **SEEK MEDICAL ATTENTION FAST!** It is a good idea to wear gloves [Figure 80-10-15] to prevent frost bite if you should get refrigerant on your hands.

**NOTE: Do Not use cotton gloves as the cotton fibers can get into the system and cause damage.**

## **WARNING**

HFC R-134a refrigerant can be dangerous if not properly handled. Liquid R-134a may cause blindness if it contacts the eyes and may cause serious frostbite if it contacts the skin.

- Gaseous R-134a becomes lethal (phosgene) gas when it contacts open flame or very hot substances.
- **NEVER SMOKE** when there is the possibility of even small amounts of R-134a in the air.

Any servicing work that involves release or addition of R-134a to the system must be done by a competent refrigeration dealer who has the proper equipment, knowledge, and experience to service refrigeration equipment.

W-2373-0611

TROUBLESHOOTING (CONT'D)

Troubleshooting Tree (Cont'd)

**Blower**

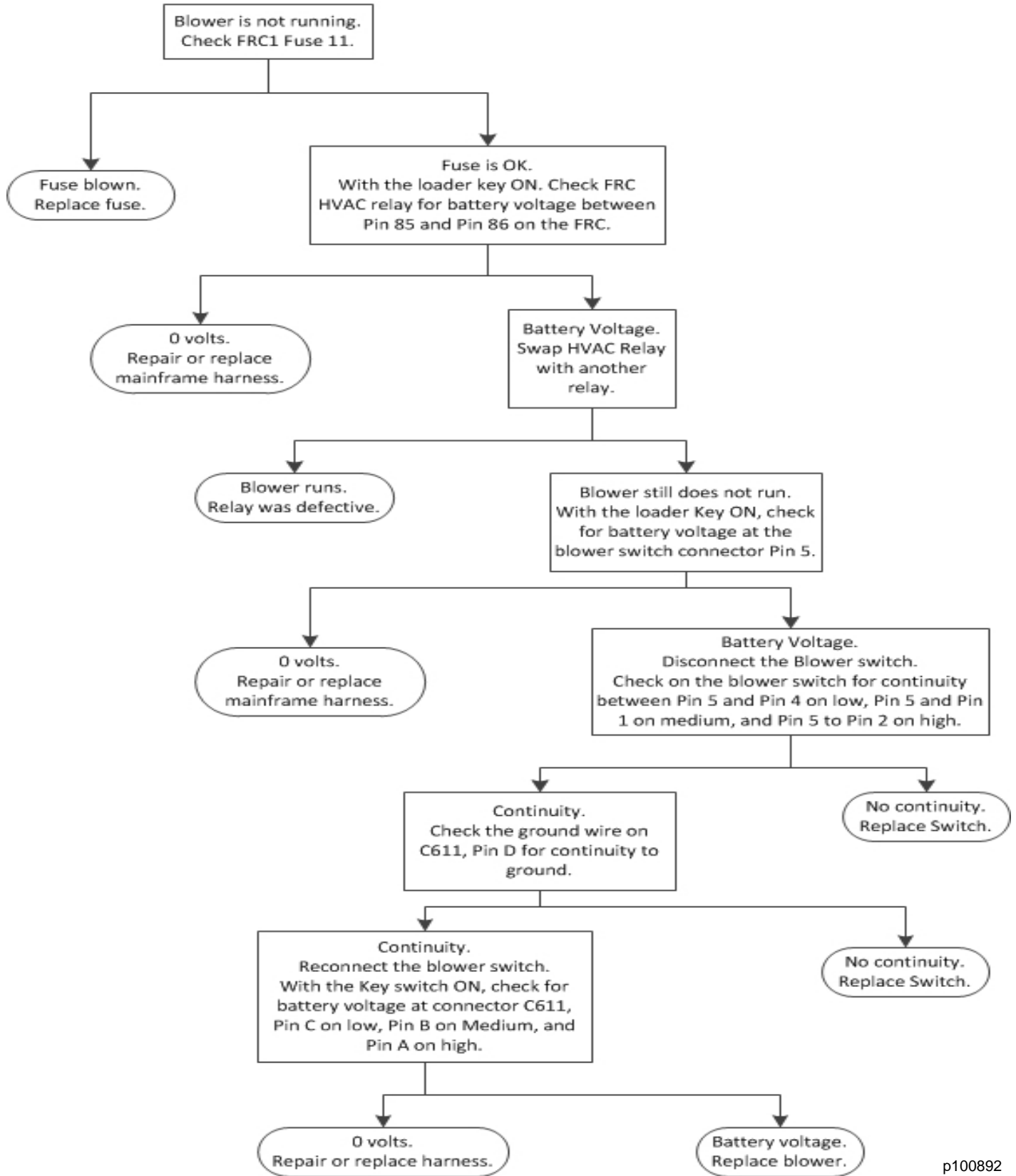

p100892

## TROUBLESHOOTING (CONT'D)

### Heater Valve Not Opening Or Closing

Raise the lift arms and install an approved lift arm support device. (See Installing on Page 10-20-1.)

**Figure 80-30-30**

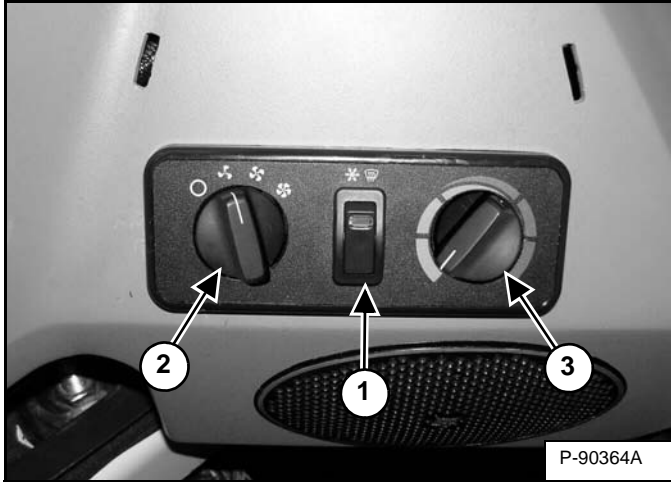

Push the A/C switch (Item 1) to the OFF position, turn the blower switch (Item 2) to position **1** and turn the temperature control (Item 3) **[Figure 80-30-30]** to the High A/C position, with the loader key switch OFF.

Raise the operator cab. (See Raising on Page 10-30-2.)

Connect the Remote Start Tool. (See REMOTE START TOOL KIT - MEL1563 on Page 10-60-1.) or (See REMOTE START TOOL (SERVICE TOOL) KIT - 7217666 on Page 10-61-1.)

**Figure 80-30-31**

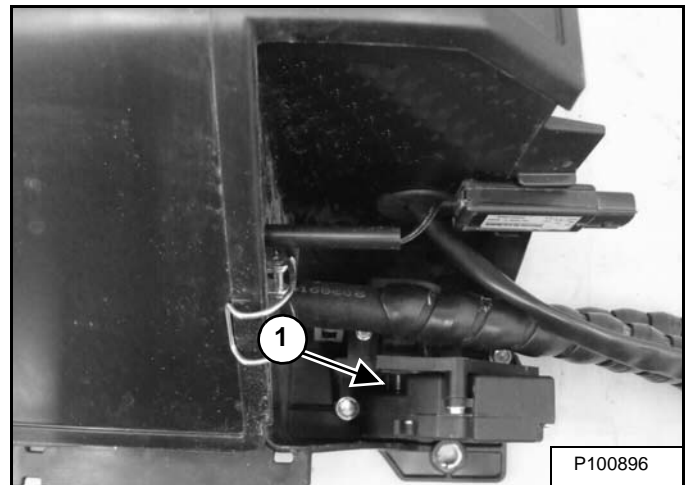

**NOTE:** The HVAC assembly is removed for photo clarity.

Place the Remote Start Tool on the left fender of the loader, so the heater valve can be clearly seen. Watch the valve shaft (Item 1) **[Figure 80-30-31]**, as the key of the remote start is turned to the ON position without starting the loader. The heater valve should rotate. Place a mark on the loader valve shaft.

Turn the remote start key to the OFF position and remove the Remote Start Tool from fender.

Lower operator cab.

Turn the temperature control (Item 3) **[Figure 80-30-30]** to the High Heater position, with the loader key switch OFF.

Raise the operator cab.

Place the Remote Start Tool on the left fender of the loader, so the heater valve can be clearly seen. Watch the valve shaft (Item 1) **[Figure 80-30-31]**, as the key of the remote start is turned to the ON position without starting the loader. The heater valve should rotate.

If it does not rotate, check the potentiometer for proper function. (See Electrical System on Page 80-30-10.)

Replace the heater valve. (See Removal And Installation on Page 80-140-1.)

## CONDENSER (LATER MODELS)

### Removal And Installation

Raise the lift arms and install an approved lift arm support device. (See Installing on Page 10-20-1.)

Raise the operator cab. (See Raising on Page 10-30-2.)

Remove the rear grille. (See Removing on Page 50-60-1.)

Remove the refrigerant from the A/C system. (See Reclamation And Charging With Recovery / Charging Unit on Page 80-40-2.)



In the event of a leak, wear safety goggles. Escaping refrigerant can cause severe injuries to eyes. In contact with a flame, R-134a refrigerant gives a toxic gas.

W-2371-0611

Figure 80-61-1

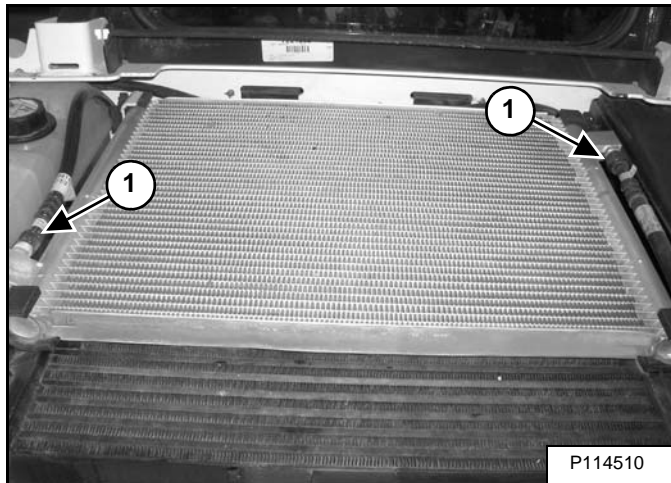

Remove the two hoses (Item 1) [Figure 80-61-1].

Cap and plug the hose and the condenser fittings with the proper A/C caps and plugs.

**Installation:** Tighten the hose (Item 1) [Figure 80-61-1] to 30 N•m (22 ft-lb) torque.

Figure 80-61-2

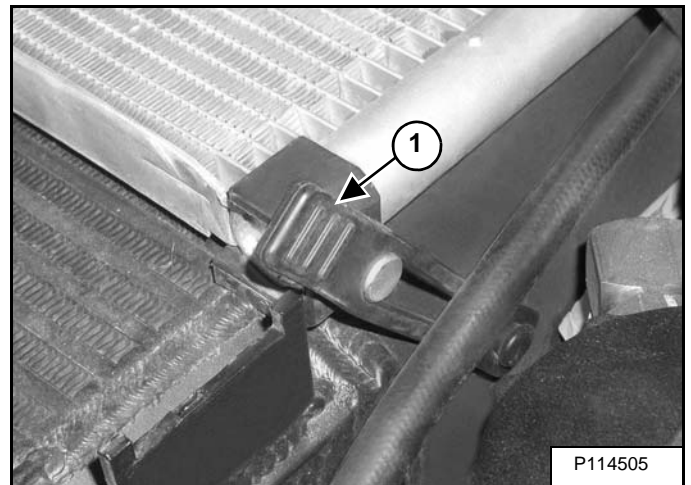

Unhook the two rubber straps (Item 1) [Figure 80-61-2].

Figure 80-61-3

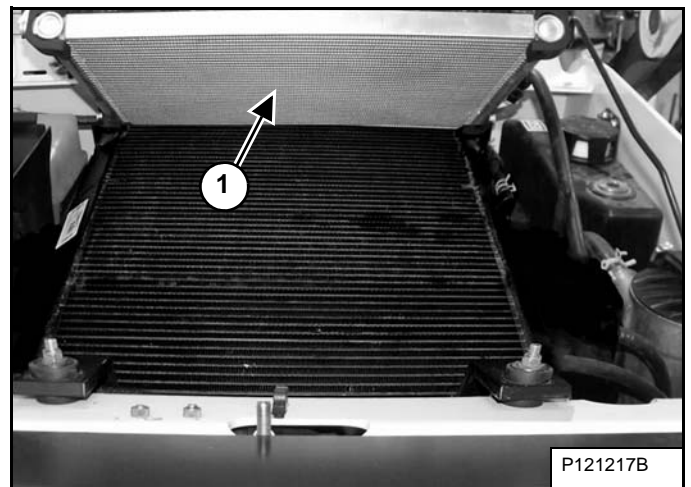

Raise the air conditioning condenser (Item 1) [Figure 80-61-3].

**NOTE:** The air conditioning condenser fits into two slotted brackets mounted on the hydraulic fluid cooler and radiator assembly. Ensure the air conditioning condenser remains connected to the brackets when raising and lowering.

## THERMOSTAT

### Description

The Electronic De-icing Thermostat (EDT) is a micro controller based module that measures evaporator coil temperature and cycles the compressor clutch to maintain a constant evaporator pressure. Onboard circuit protection and diagnostics are also built into the module.

**NOTE: The EDT has a six second delay before start up to protect the compressor clutch.**

The EDT will turn the clutch on when the evaporator coil temperature is above 2°C (35.6°F). If the EDT does not detect any malfunction, it will continue to operate and the status LED will be lit continuously. When the evaporator temperature is below -2°C (28.4°F), the EDT will turn off the clutch and status LED.

**Figure 80-90-1**

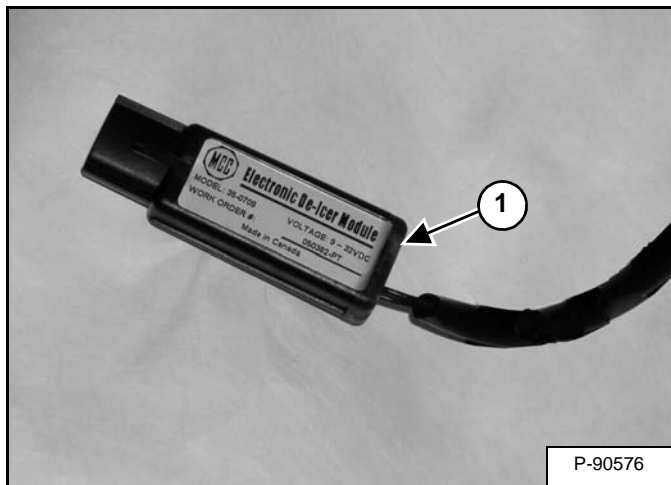

When the EDT detects an open or short from the temperature sensor, the status LED (Item 1) [Figure 80-90-1] will blink once per second and the output signal to the clutch will be turned off. The status LED will flash two times per second when EDT detects an open circuit (current draw less than 200 mA), short circuit or over current, (current draw greater than 7A) from the clutch output. The status LED will flash three times per second when the compressor clutch is shorted to ground.

**NOTE: The EDT will attempt to restart every 20 seconds until the fault is repaired.**

**The EDT has the following protection built in:**

1. Over temperature
2. Over current from clutch output
3. Voltage (Above and below operational limits or reverse voltage)
4. Short circuit protection (Output shorted to ground)
5. Temperature sensor open and short detection

MALFUNCTION	DETECTION INTERVAL	STATUS LED
Temperature sensor open or short detection	Continuous	1x per second
Clutch circuit open, short or over current	At A/C start up	2x per second
Compressor clutch short to ground	Continuous	3x per second

**NOTE: When the status LED is flashing, it does NOT mean the module is OFF. It may restart in approximately 20 seconds. Keep away from all rotating parts to prevent injury.**

The EDT is able to detect short circuit from clutch output to ground. When a short is detected, the output will be turned off and turning back on in approximately 20 seconds while the status LED will flash to indicate there is a malfunction.

## HEATER VALVE

### Removal And Installation

Remove the evaporator / heater cover. (See Removal on Page 80-150-1.)

**NOTE: The heater valve is not serviceable and must be replaced as a complete assembly.**

Remove any tie-straps that hold the heater hoses.

**NOTE: The evaporator / heater unit is shown removed for photo clarity.**

Figure 80-140-1

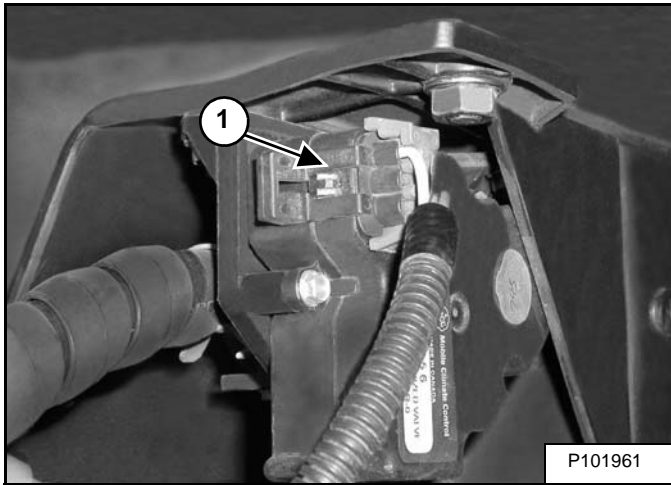

Disconnect the loader wiring harness (Item 1) [Figure 80-140-1] from the heater valve.

Figure 80-140-2

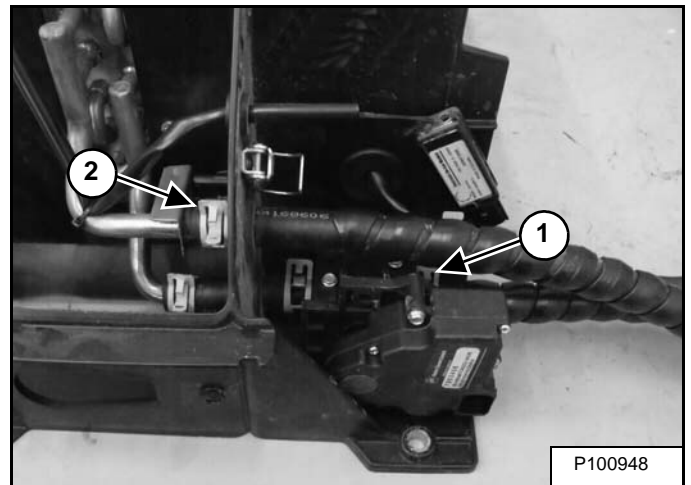

**NOTE: Cap the heater hoses and the heater valve with plugs to prevent coolant loss from the system.**

Remove the heater hose clamp (Item 1) [Figure 80-140-2].

Remove the heater hose from the heater valve.

Remove the heater hose clamp (Item 2) [Figure 80-140-2].

Remove the heater hose from the heater coil.

CLICK HERE TO **DOWNLOAD** THE COMPLETE MANUAL

- Thank you very much for reading the preview of the manual.
- You can download the complete manual from: [www.heydownloads.com](http://www.heydownloads.com) by clicking the link below



- Please note: If there is no response to CLICKING the link, please download this PDF first and then click on it.

CLICK HERE TO **DOWNLOAD** THE COMPLETE MANUAL