

T3571

**S/N 362811001
& above**

T3571L

**S/N 362911001
& above**



Bobcat®

**SERVICE
MANUAL**

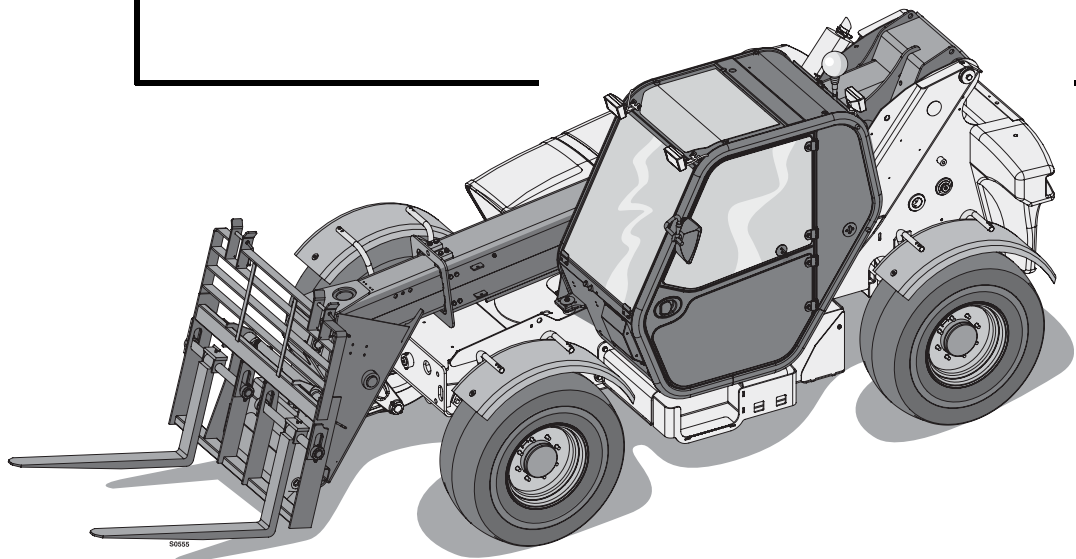

CLICK HERE TO **DOWNLOAD** THE COMPLETE MANUAL

- Thank you very much for reading the preview of the manual.
- You can download the complete manual from: www.heydownloads.com by clicking the link below



- Please note: If there is no response to CLICKING the link, please download this PDF first and then click on it.

CLICK HERE TO **DOWNLOAD** THE COMPLETE MANUAL

SAFETY INSTRUCTIONS

Before Operation

Carefully follow the operating and maintenance instructions in this manual.

The Bobcat Telescopic Handler is highly maneuverable and compact. It is rugged and useful under a wide variety of conditions. This presents an operator with hazards associated with off highway, rough terrain applications, common with Bobcat Telescopic Handler usage.

The Bobcat Telescopic Handler has an internal combustion engine with resultant heat and exhaust. All exhaust gasses can kill or cause illness so use the Telescopic Handler with adequate ventilation.

The dealer explains the capabilities and restrictions of the Bobcat Telescopic Handler and attachment for each application. The dealer demonstrates the safe operation according to Bobcat instructional materials, which are also available to operators. The dealer can also identify unsafe modifications or use of unapproved attachments. The attachments and buckets are designed for a Rated Load Capacity. They are designed for secure fastening to the Bobcat Telescopic Handler. The user must check with the dealer, or Bobcat literature, to determine safe loads of materials of specified densities for the machine - attachment combination.

The following publications and training materials provide information on the safe use and maintenance of the Bobcat machine and attachments:

- The Delivery Report is used to assure that complete instructions have been given to the new owner and that the machine and attachment is in safe operating condition.
- The Operation & Maintenance Manual delivered with the machine or attachment gives operating information as well as routine maintenance and service procedures. It is a part of the machine and can be stored in a container provided on the machine. Replacement Operation & Maintenance Manuals can be ordered from your Bobcat dealer.
- Machine signs (decals) instruct on the safe operation and care of your Bobcat machine or attachment. The signs and their locations are shown in the Operation & Maintenance Manual. Replacement signs are available from your Bobcat dealer.
- Load Capacity Charts for each attachment are provided in the operator area. These charts indicate the Rated Load Capacity for each attachment at specified boom heights and extensions. Replacement or additional charts for new attachments are available from your Bobcat dealer.

- An Operator's Handbook is fastened to the operator cab of the Telescopic Handler. It's brief instructions are convenient to the operator. The Handbook is available from your dealer in an English edition or one of many other languages. See your Bobcat dealer for more information on translated versions.
- The AEM Safety Manual delivered with the machine gives general safety information.
- The "Safety Training for Operators of the Bobcat Telescopic Handler" course is available through your Bobcat dealer. This course is intended to provide rules and practices of correct operation of the Bobcat Telescopic Handler. The course is available in English and Spanish versions.
- See the PUBLICATIONS AND TRAINING RESOURCES Page in this manual or your Bobcat dealer for Service and Parts Manuals, printed materials, videos, or training courses available. Also check the Bobcat web sites www.training.bobcat.com or www.bobcat.com

The dealer and owner/operator review the recommended uses of the product when delivered. If the owner/operator will be using the machine for a different application(s) he or she must ask the dealer for recommendations on the new use.

TRANSPORTING THE Telescopic Handler

Procedure

Always drive the Telescopic Handler backwards (heavy end up) onto the transport vehicle.

Figure 10-30-1

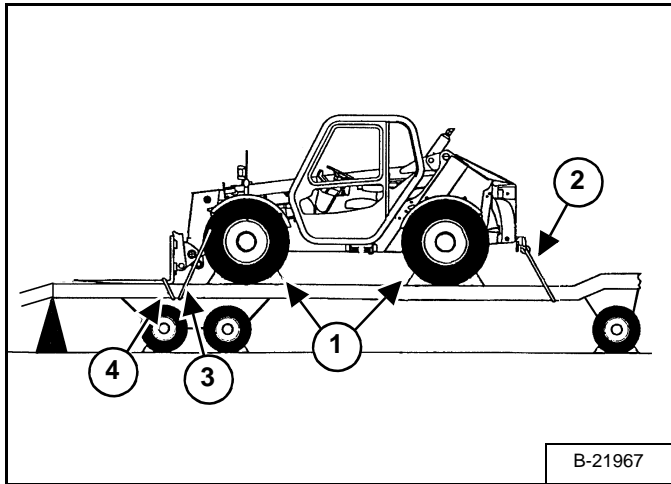

The rear of the trailer must be blocked or supported [Figure 10-30-1] when loading or unloading the Telescopic Handler to prevent the front end of the trailer from raising up.

Be sure the transport and towing vehicles are of adequate size and capacity. (See "Telescopic Handler SPECIFICATIONS" on page SPEC-10-1 for weight of the Telescopic Handler).

Fasten the Telescopic Handler to the transport vehicle to prevent it from moving during sudden stops or when going up or down slopes.

- Block the wheels (Item 1) [Figure 10-30-1].
- Fasten the machine frame to the transport vehicle (Items 2 & 3) [Figure 10-30-1].
- Attach the forks or bucket attachment to the transport vehicle (Item 4) [Figure 10-30-1].

WARNING

Adequately designed ramps of sufficient strength are needed to support the weight of the machine when loading onto a transport vehicle. Wood ramps can break and cause personal injury.

W-2058-0494

ENGINE COOLING SYSTEM

Check the cooling system every day to prevent overheating, loss of performance or engine damage.

WARNING

Wear safety glasses to prevent eye injury when any of the following conditions exist:

- When fluids are under pressure.
- Flying debris or loose material is present.
- Engine is running.
- Tools are being used.

W-2019-1285

Cleaning The Cooling System

Figure 10-70-1



Open the engine cover (Item 1) [Figure 10-70-1].

Figure 10-70-2

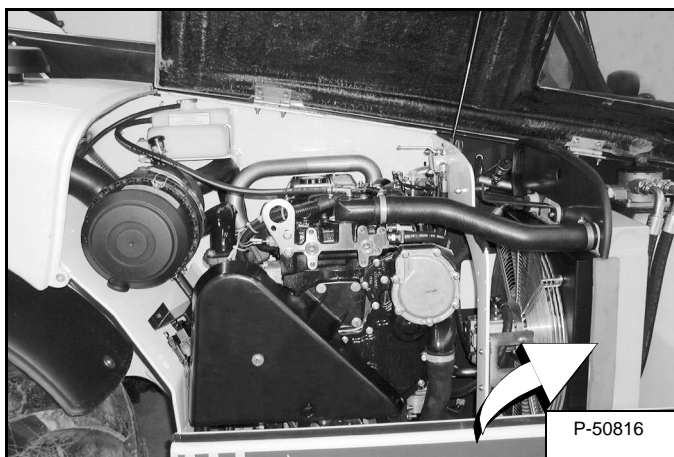

Use low air pressure or water pressure to clean the radiator and oil cooler [Figure 10-70-2].

Checking The Coolant Level

Open the engine cover.

Check the coolant level in the coolant reservoir.

Figure 10-70-3

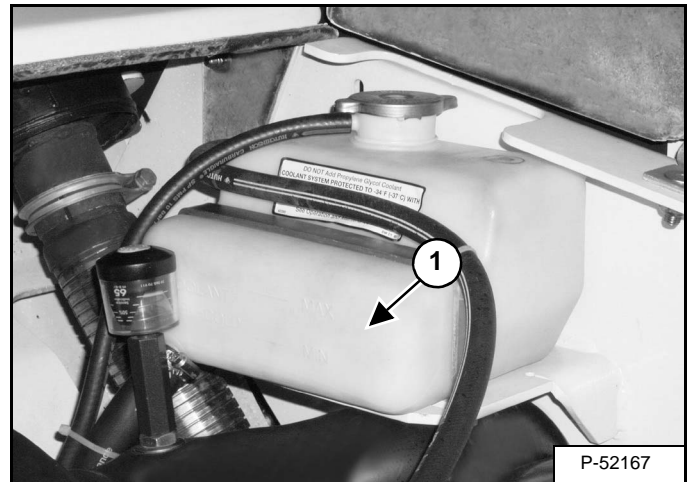

The coolant level must be between the MIN and MAX marks (Item 1) [Figure 10-70-3] on the coolant reservoir when the engine is cold.

Close the engine cover.

IMPORTANT

AVOID ENGINE DAMAGE

Always use the correct ratio of water to antifreeze.

Too much antifreeze reduces cooling system efficiency and may cause serious premature engine damage.

Too little antifreeze reduces the additives which protect the internal engine components; reduces the boiling point and freeze protection of the system.

Always add a premixed solution. Adding full strength concentrated coolant can cause serious premature engine damage.

I-2124-0497

AXLES (FRONT AND REAR) (For S/N 362811001 - 362812000, S/N 362911001 - 362912000)

Checking Oil Level (Planetary Carrier)

Figure 10-110-1

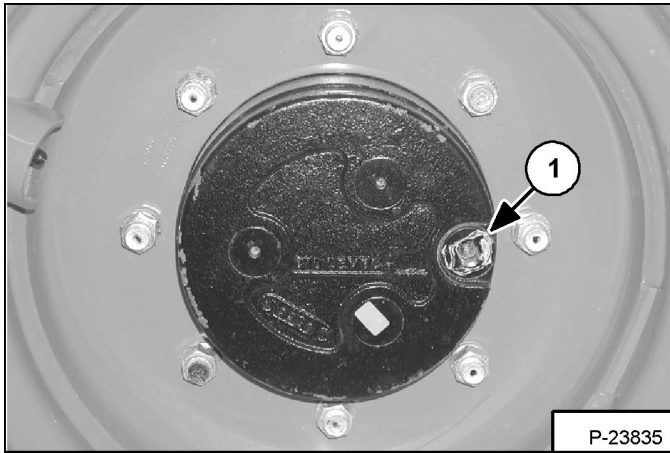

Put the machine on a level surface with the plug (Item 1) **[Figure 10-110-1]** positioned as shown.

Remove the plug (Item 1) **[Figure 10-110-1]**. The oil level should be at the bottom edge of the plug hole.

Add gear lube through the hole if the oil level is below the hole. (See "Capacities" on page SPEC-10-3 for capacity and type.)

Install and tighten the plug.

Repeat the procedure for the other side.

Draining Oil (Planetary Carrier)

See "SERVICE SCHEDULE" on page 10-50-1 for the correct service interval.

Figure 10-110-2

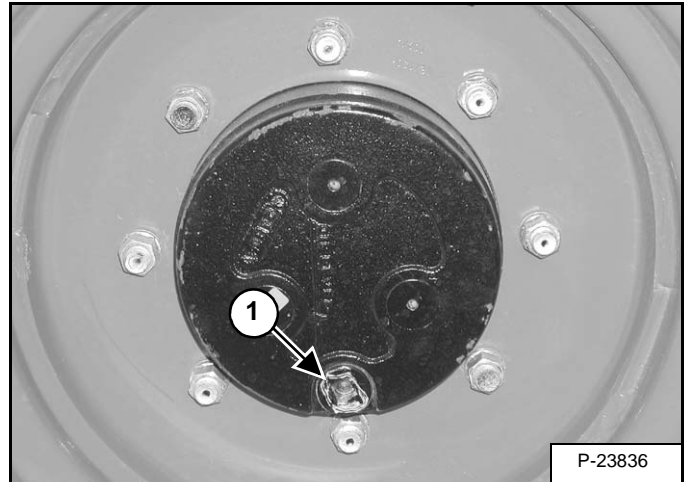

Put the machine on a level surface with the plug (Item 1) **[Figure 10-110-2]** positioned as shown.

Remove the plug (Item 1) **[Figure 10-110-2]** and drain into a container. Recycle or dispose of the used lubricant in an environmentally safe manner.

Reposition the plug hole and add gear lube until the lube level is at the bottom edge of the plug hole (Item 1) **[Figure 10-110-1]**. (See "Capacities" on page SPEC-10-3 for capacity and type.)

Install and tighten the plug.

Repeat the procedure for the other side.

LUBRICATION (For S/N 362811001 - 362812000, S/N 362911001 - 362912000) (CONT'D)

Procedure (Cont'd)

Figure 10-120-17

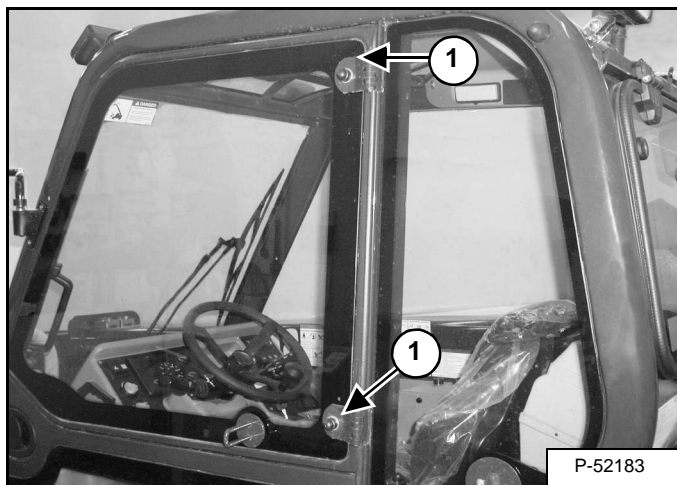

17. Cab door hinges (upper) (Item 1) [Figure 10-120-17]

Figure 10-120-18

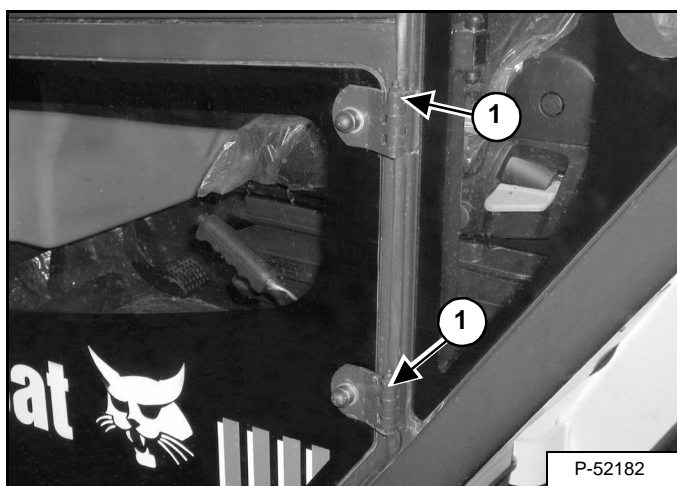

18. Cab door hinges (lower) (Item 1) [Figure 10-120-18]

SPARK ARRESTOR MUFFLER

Cleaning

See "SERVICE SCHEDULE" on page 10-50-1 for the service interval for cleaning the spark arrestor muffler.

Do not operate the machine with a defective exhaust system.

Stop the engine.

Figure 10-140-3

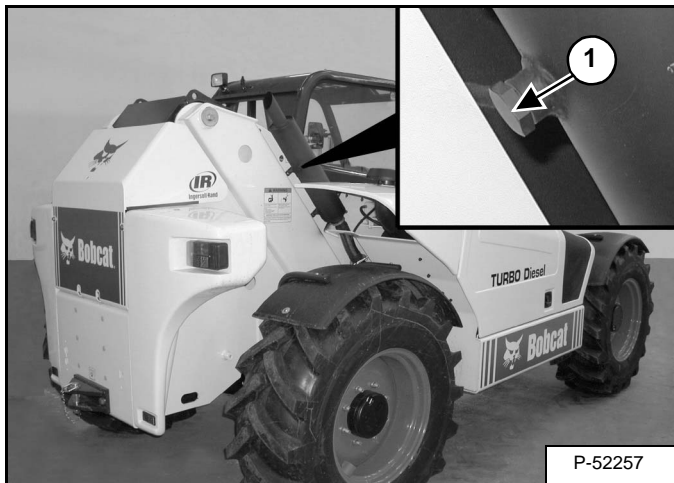

Remove the plug (Item 1) [Figure 10-140-3] from the bottom of the muffler.

WARNING

When the engine is running during service, the Travel Direction Lever must be in neutral and the parking brake engaged. Failure to do so can cause injury or death.

W-2397-0301

Start the engine and run for about 10 seconds while a second person, wearing safety glasses, holds a piece of wood over the outlet of the muffler.

This will force contaminants out through the clean out hole.

Stop the engine.

Install and tighten the plug.

IMPORTANT

This loader is factory equipped with a U.S.A.. Forestry Service approved spark arrestor muffler. It is necessary to do maintenance on this spark arrestor muffler to keep it in working condition. The spark arrestor muffler must be serviced by dumping the spark chamber every 100 hours of operation.

If this machine is operated on flammable forest, brush or grass covered land, it must be equipped with a spark arrestor attached to the exhaust system and maintained in working order. Failure to do so will be in violation of California State Law, Section 4442 PRC. Make reference to local laws and regulations for spark arrestor requirements.

I-2022-0595

GLOSSARY OF HYDRAULIC/HYDROSTATIC SYMBOLS

SYMBOL DESCRIPTION

SYMBOL DESCRIPTION

FLOW LINES and CONNECTIONS

BASIC and MISCELLANEOUS SYMBOLS

 WORKING CIRCUITS - Continuous, Solid Line - Working (Main) Line, Return Line (line conducting fluid from working devices to the reservoir) and Feed Line (main line conductor)

 RESTRICTION - Line with Fixed Restriction - Affected by Viscosity (property of resistance to flowing fluid)

 PILOT PRESSURE - Dashed Line - Pilot Line (line which conducts control fluid)

 VARIABLE ADJUSTMENT RESTRICTION - Regulated or Variable Restriction

 DRAIN CIRCUITS - Dotted Line - Drain Line (drain or bleed line - line conducting fluid from a component housing to the reservoir)

 TEMPERATURE CONTROL - (indication of temperature)

 COMPONENTS - Long Chain Line - Enclosure outline for several components assembled in one unit

 TEMPERATURE INDICATOR - (temperature measurement - thermometer)

 MECHANICAL CONNECTIONS - Double Line (Shaft, Lever, Piston Rod)

 FILTER (strainer or screen) - For fluid conditioning

 CONNECTED JUNCTION OF OIL LINES (Flow Line Connection)

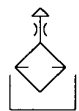
 VENTED AND FILTERED RESERVOIR (reservoir open to atmosphere)

 OIL LINES CROSSING (NOT Connected)

 OIL COOLER (heat exchanger) - The arrows in the diamond indicate the extraction of heat (heat dissipation)

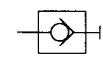
 COUPLER - Quick-Acting Coupling (uncoupled, closed by non-return valve)

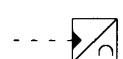
 PRESSURE SENSOR - Varies electric signal with pressure

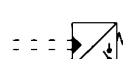
 DIFFERENTIAL PRESSURE SWITCH - Switch activates when pressure difference reaches specified level

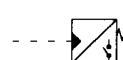
 PRESSURE SWITCH - Switch activates when pressure reaches specified level

 MUFFLER (silencer) - Reduces noise

mc-2340

LIFT CYLINDER (CONT'D)

Assembly (Cont'd)

Figure 20-20-50

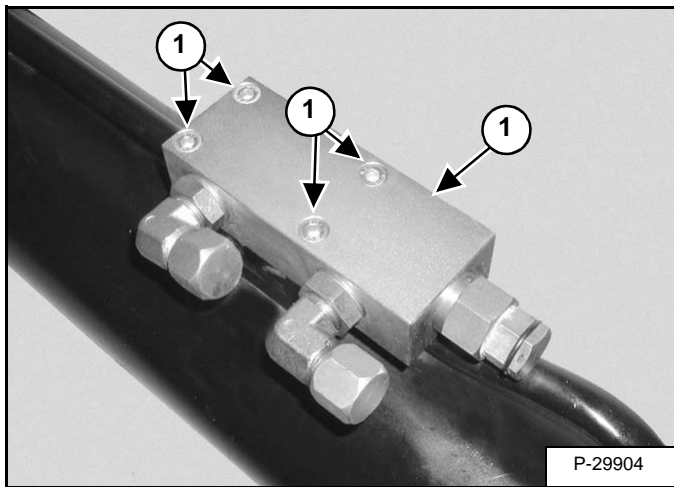

Install the lift lock (Item 1) onto the cylinder and tighten the four bolts (Item 2) [Figure 20-20-50].

BUCKET POSITIONING CYLINDER (CONT'D)

Assembly

Use the following tools to assemble the cylinder:

MEL1354-Spanner Wrench

MEL1033-Rod Seal Installation Tool

Wash the cylinder parts in solvent and dry with compressed air.

Inspect the cylinder parts for nicks, scratches or other damage. Replace any damaged parts.

Lubricate all O-rings and seals with hydraulic oil during installation.

Always use new O-rings and seals.

Figure 20-30-26

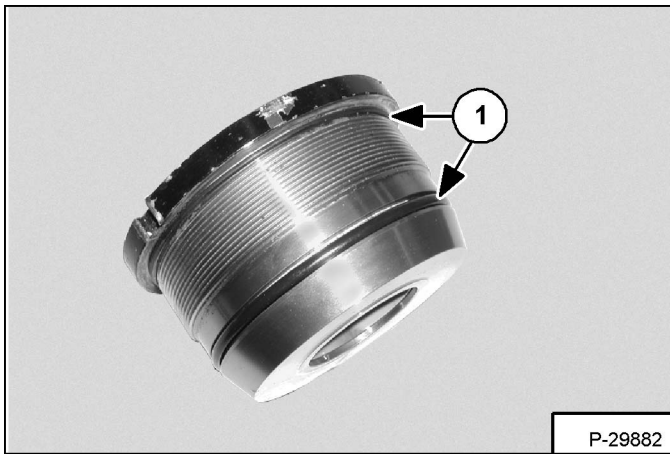

Install the two O-rings (Item 1) [Figure 20-30-26] onto the head gland.

Figure 20-30-27

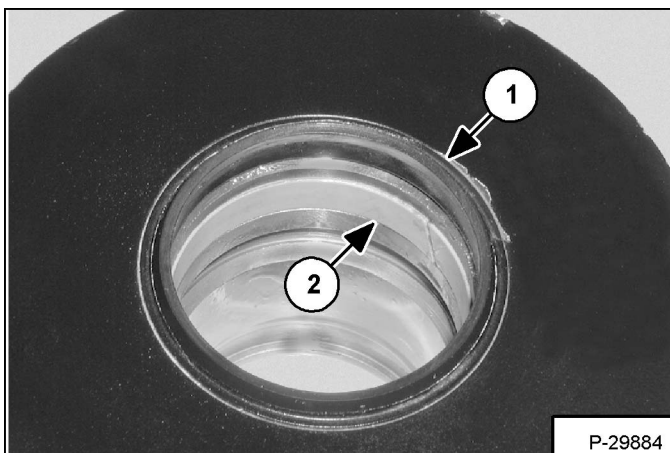

Install the wiper (Item 1) and wear ring (Item 2) [Figure 20-30-27].

Figure 20-30-28

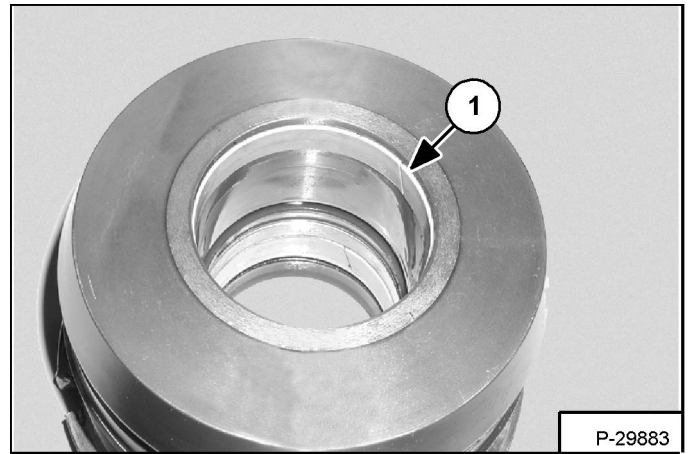

Install the wear ring (Item 1) [Figure 20-30-28].

Figure 20-30-29



Install the center seal (Item 1) [Figure 20-30-29].

NOTE: The groove in the seal must point away from the wiper seal (Item 1) [Figure 20-30-27].

EXTENSION CYLINDER (CONT'D)

Extension Cylinder Removal And Installation (Cont'd)

Figure 20-40-25

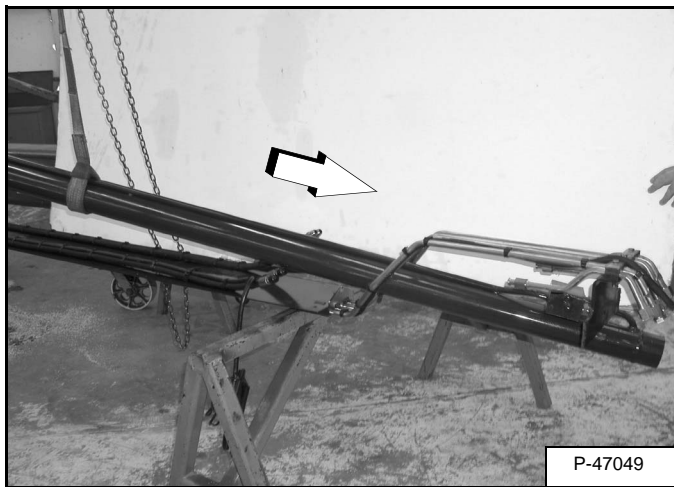

Slide the extension cylinder through the tubelines [Figure 20-40-25] and remove the cylinder.

NOTE: It may be necessary to reposition the lifting strap.

Tubeline Tray Disassembly

Figure 20-40-26

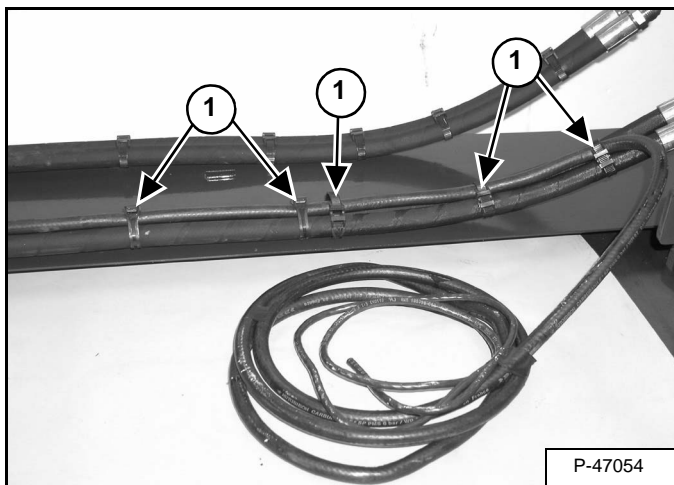

Remove all tie straps (Item 1) [Figure 20-40-26] securing the electrical harness to the hoses.

Figure 20-40-27

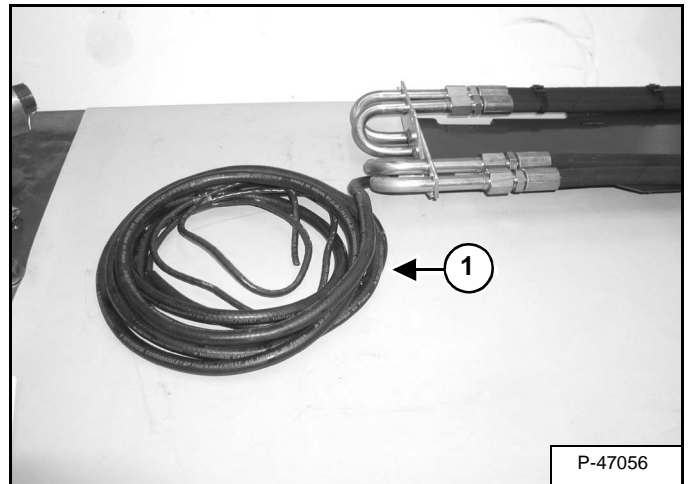

Temporarily roll up the electrical harness (Item 1) [Figure 20-40-27].

Figure 20-40-28

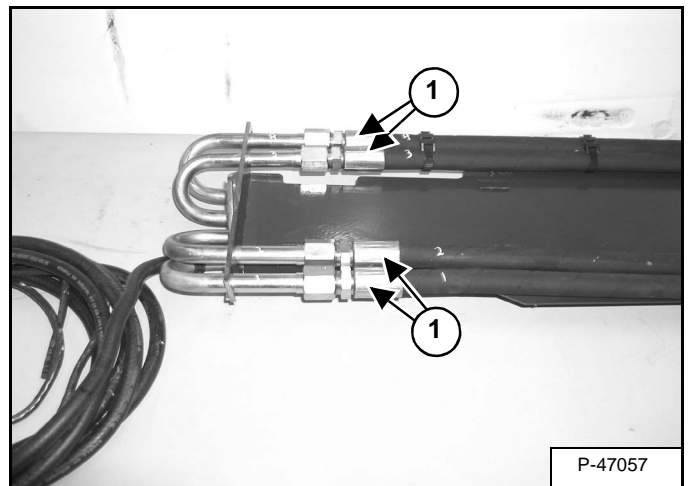

Remove the four hoses (Item 1) [Figure 20-40-28] from the tubelines.

NOTE: Mark the hoses for correct assembly.

EXTENSION CYLINDER (CONT'D)

Disassembly (Cont'd)

Figure 20-40-58

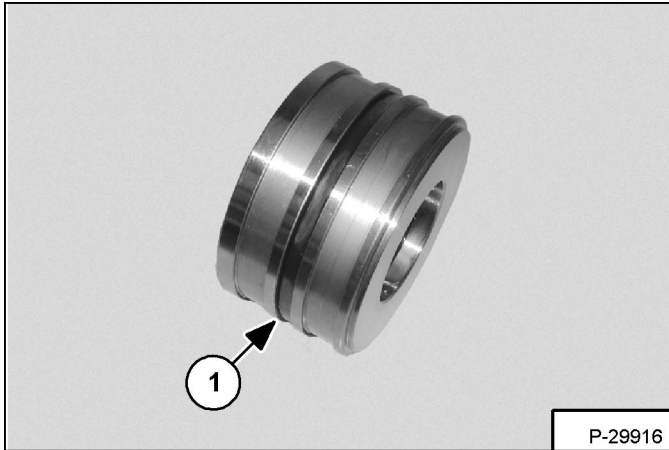

Remove the expander O-ring (Item 1) [Figure 20-40-58].

Figure 20-40-59

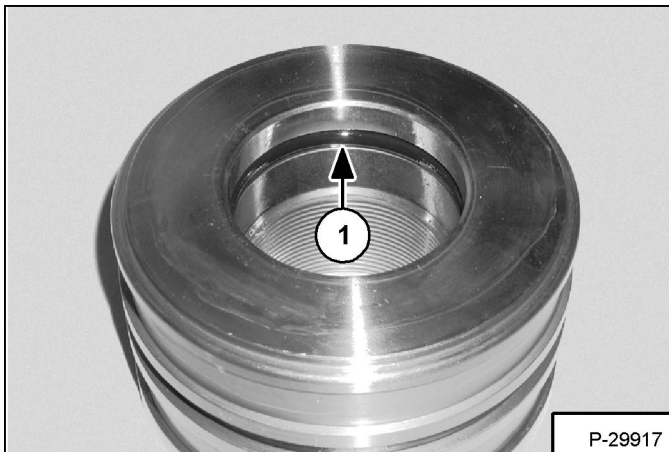

Remove the O-ring (Item 1) [Figure 20-40-59] from the piston.

Figure 20-40-60

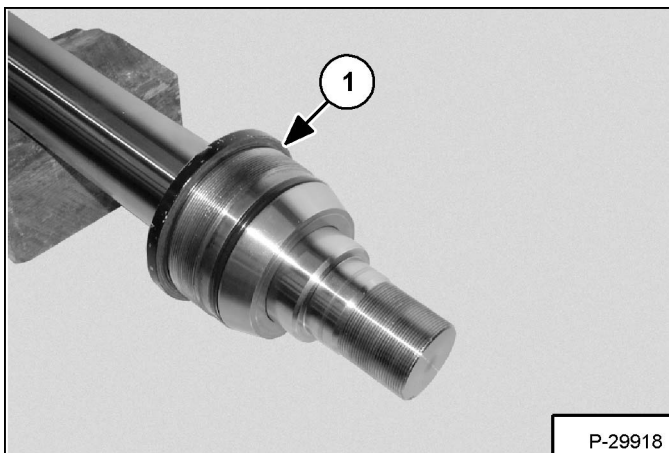

Remove the head gland (Item 1) [Figure 20-40-60] from the rod.

Figure 20-40-61

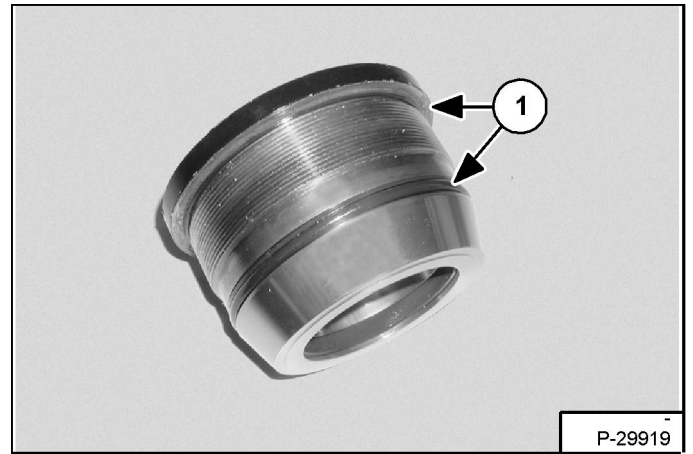

Remove the two O-rings (Item 1) [Figure 20-40-61] from the head gland.

TILT CYLINDER (CONT'D)

Disassembly (Cont'd)

Figure 20-50-13

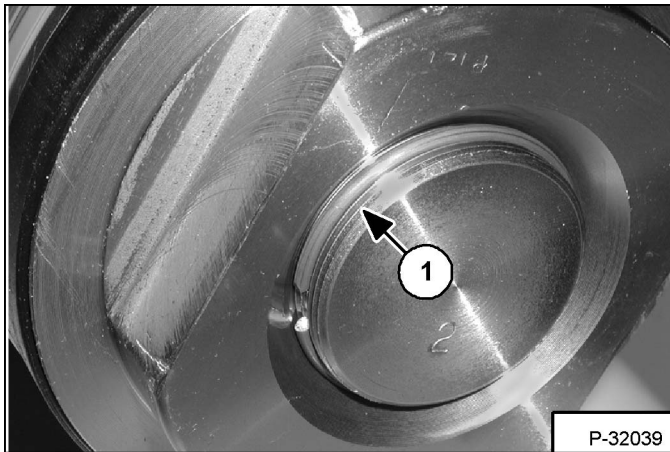

Remove the lock ring (Item 1) [Figure 20-50-13].

Figure 20-50-14

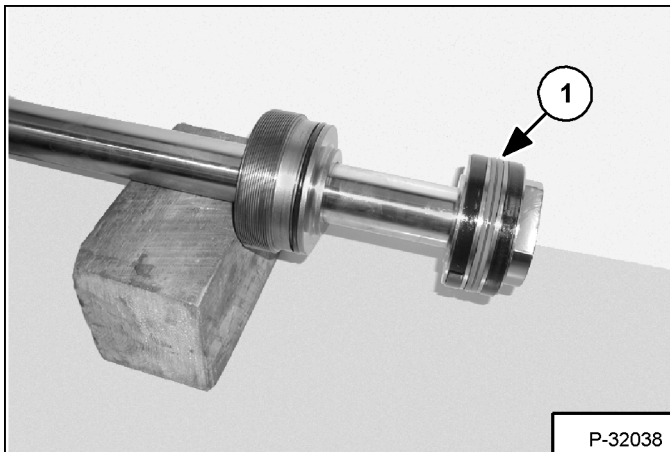

Remove the piston (Item 1) [Figure 20-50-14] from the rod.

Figure 20-50-15

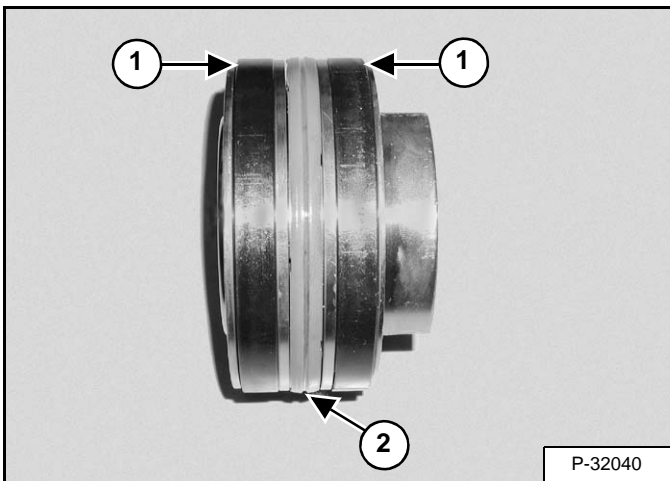

Remove the two wear rings (Item 1) and seal (Item 2) [Figure 20-50-15] from the piston.

Figure 20-50-16

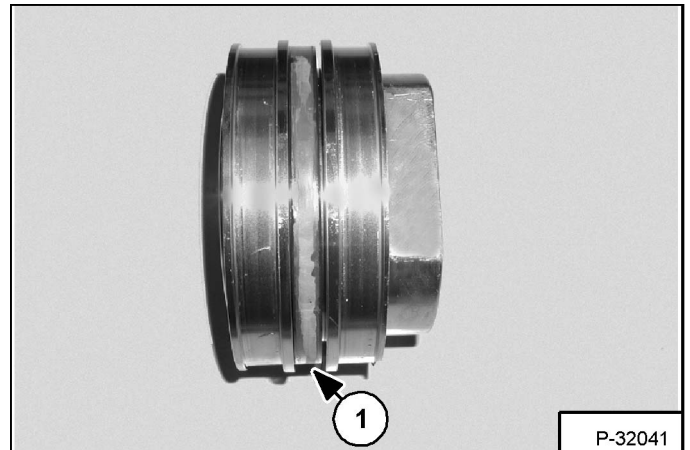

Remove the expander O-ring (Item 1) [Figure 20-50-16].

STEERING CYLINDER (FRONT) (For S/N 362811001 - 362812000, S/N 362911001 - 362912000) (CONT'D)

Disassembly (Cont'd)

Figure 20-60-13

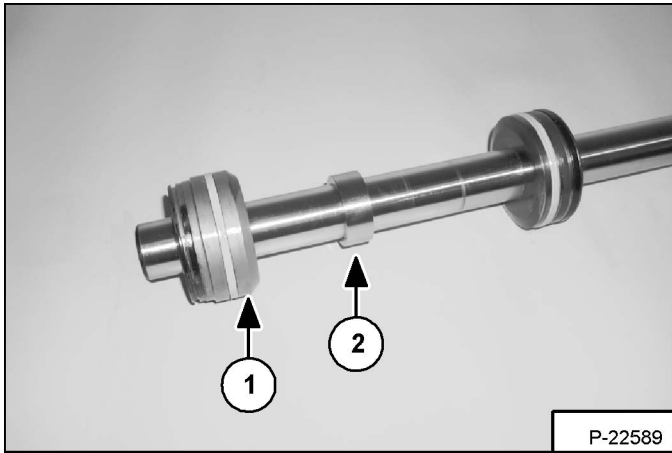

Remove the head assembly (Item 1) and spacer (Item 2) [Figure 20-60-13] from the rod.

Figure 20-60-14

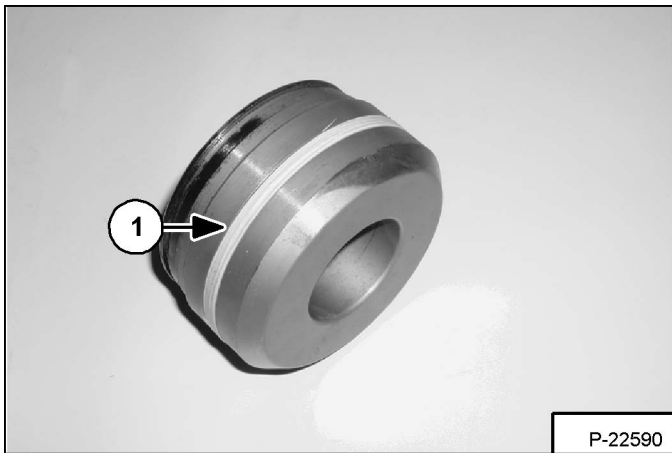

Remove the outer seal (Item 1) [Figure 20-60-14] from the head.

Figure 20-60-15

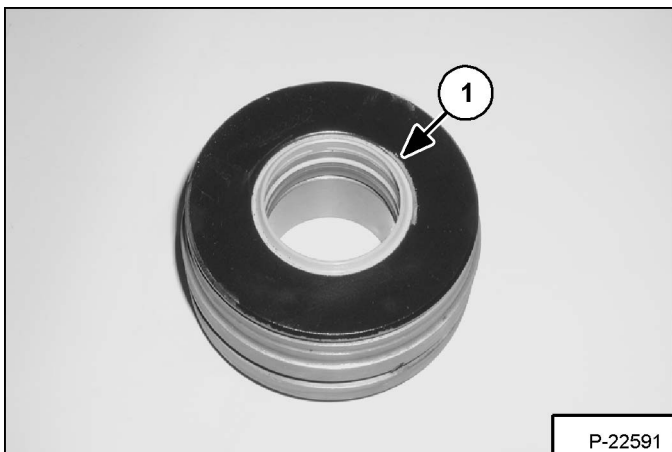

Remove the wiper seal (Item 1) [Figure 20-60-15].

Figure 20-60-16

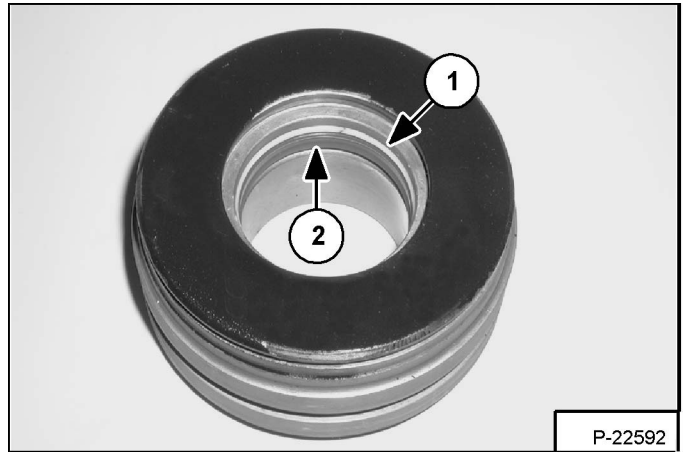

Remove the backup ring (Item 1) and rod seal (Item 2) [Figure 20-60-16] from the head gland.

STEERING CYLINDER (FRONT) (For S/N 362812001 and Above, S/N 362912001 and Above) (CONT'D)

Installing the Steering Cylinder

Figure 20-61-9

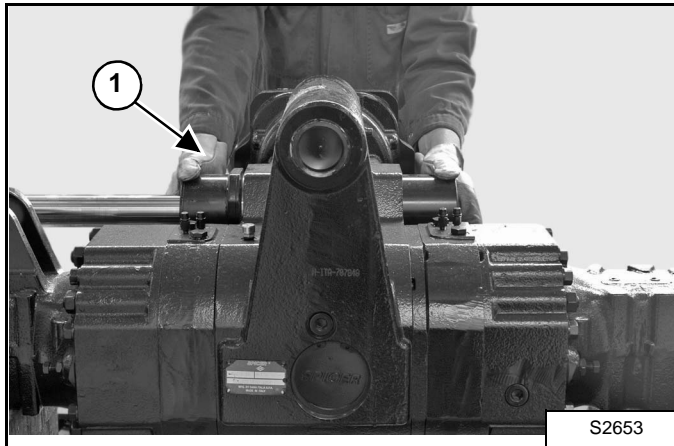

Lubricate the seats of the seals and fit the steering cylinder (Item 1) [Figure 20-61-9] into its seat.

Figure 20-61-10



Tighten the screws (Item 1) [Figure 20-61-10].

Torque wrench setting: 116 - 128 Nm.

Figure 20-61-11

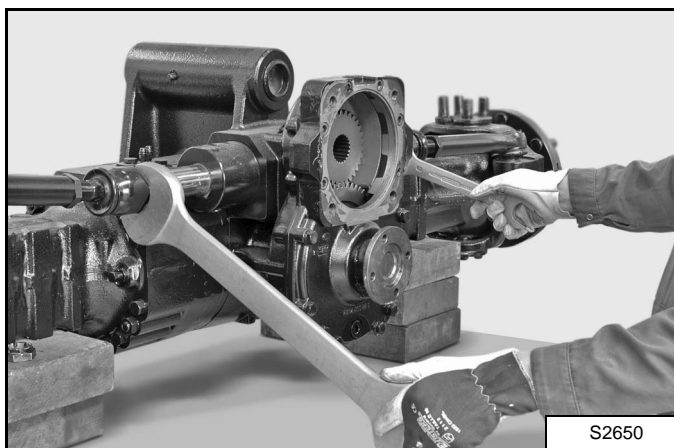

Apply Loctite 242 to the thread and connect the steering bars by screwing the terminals onto the piston stem, apply a torque of 240 - 270 Nm.

NOTE: It is required that the rim of the articulation is riveted onto the surfaces of the piston stem.

Figure 20-61-12

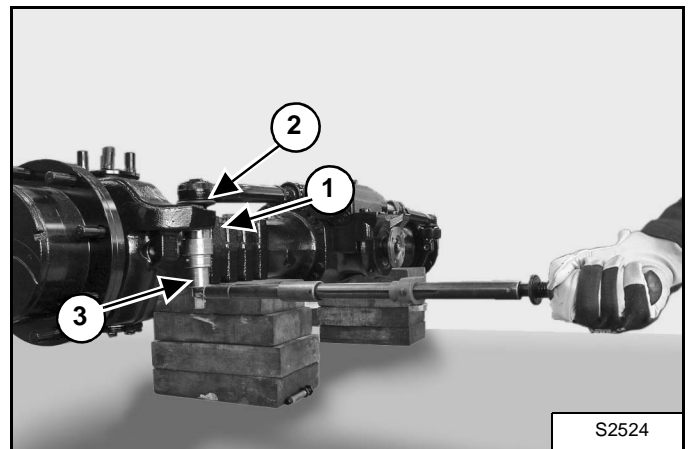

Insert the pins (Item 1) in the steering case (Item 2) [Figure 20-61-12] and lock into position using a torque wrench setting of 260 - 290 Nm.

Find the position of the notching in relation to the hole of the cotter pins and tighten the nut (Item 3) [Figure 20-61-12] further.

NOTE: Check that the rubber guards [Figure 20-61-12] are intact.

STEERING CYLINDER (REAR) (For S/N 362811001 - 362812000, S/N 362911001 - 362912000) (CONT'D)

Parts Identification

- 1. Swivel End
- 2. Wiper
- 3. Backup Washer
- 4. Seal
- 5. Housing
- 6. Rod
- 7. O-Ring
- 8. Magnetic Sensor
- 9. Wear Ring
- 10. Spacer
- 11. Head Gland
- 12. Split Ring
- 13. Snap Ring

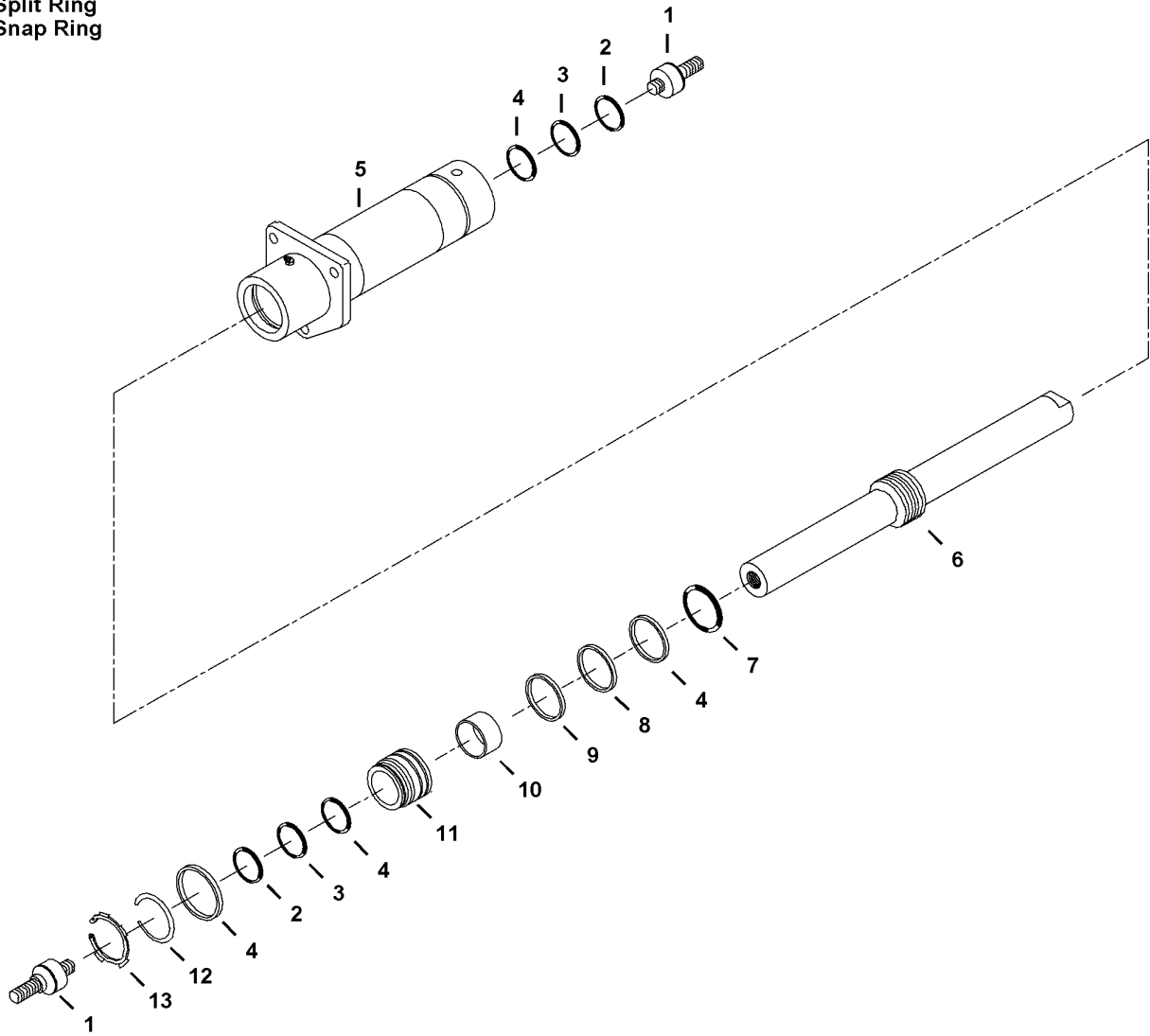

MS-01116

STEERING CYLINDER (REAR) (For S/N 362812001 and Above, S/N 362912001 and Above)

Removing the Steering Cylinder

Figure 20-63-1

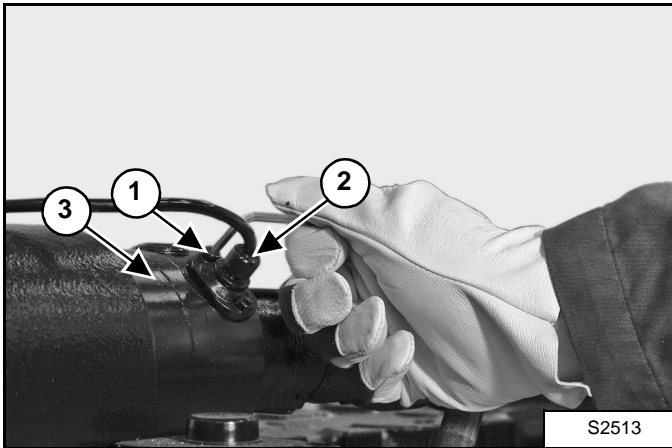

Remove the two bolts (Item 1) and remove the centering sensor (Item 2) from the steering cylinder (Item 3) [Figure 20-63-1].

Figure 20-63-2

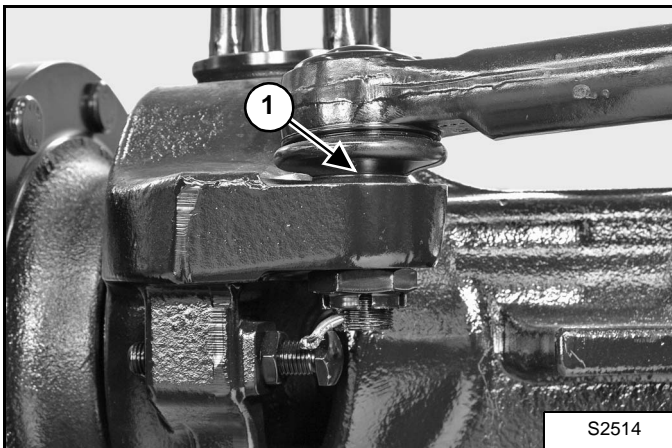

Remove the cotter pin (Item 1) [Figure 20-63-2].

Figure 20-63-3

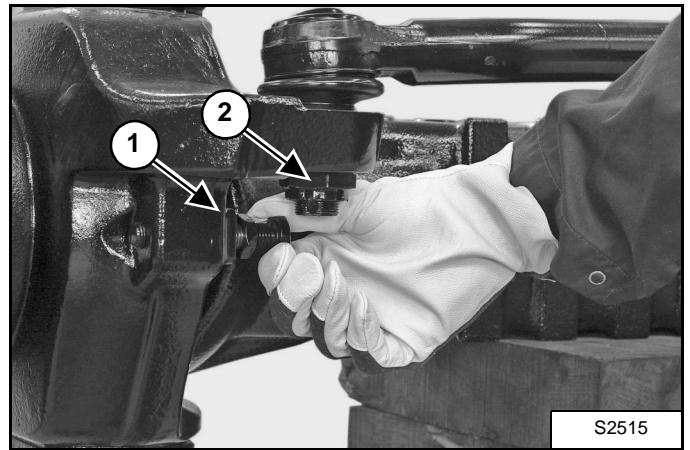

Remove the bolt (Item 1) for access for removing the nut (Item 2) [Figure 20-63-3].

Figure 20-63-4

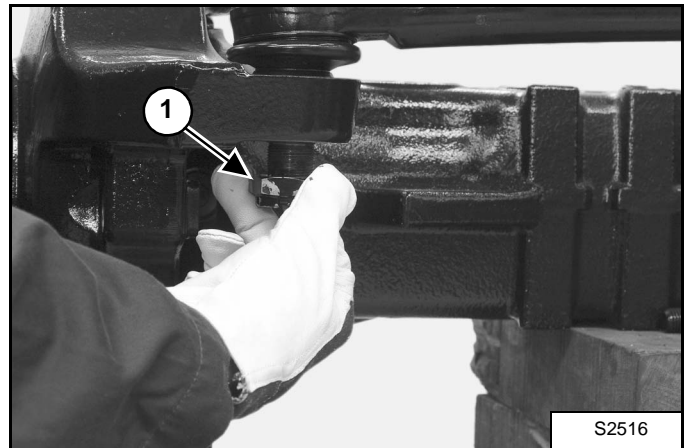

Remove the nut (Item 1) [Figure 20-63-4].

Parts Identification

- 1. O-Ring
- 2. Bolt
- 3. Mounting Flange
- 4. Washer
- 5. Tubeline
- 6. Plug
- 7. Housing
- 8. Breather
- 9. Bearing
- 10. Gear
- 11. Plug
- 12. Shaft
- 13. Seal
- 14. Snap Ring
- 15. Dowel

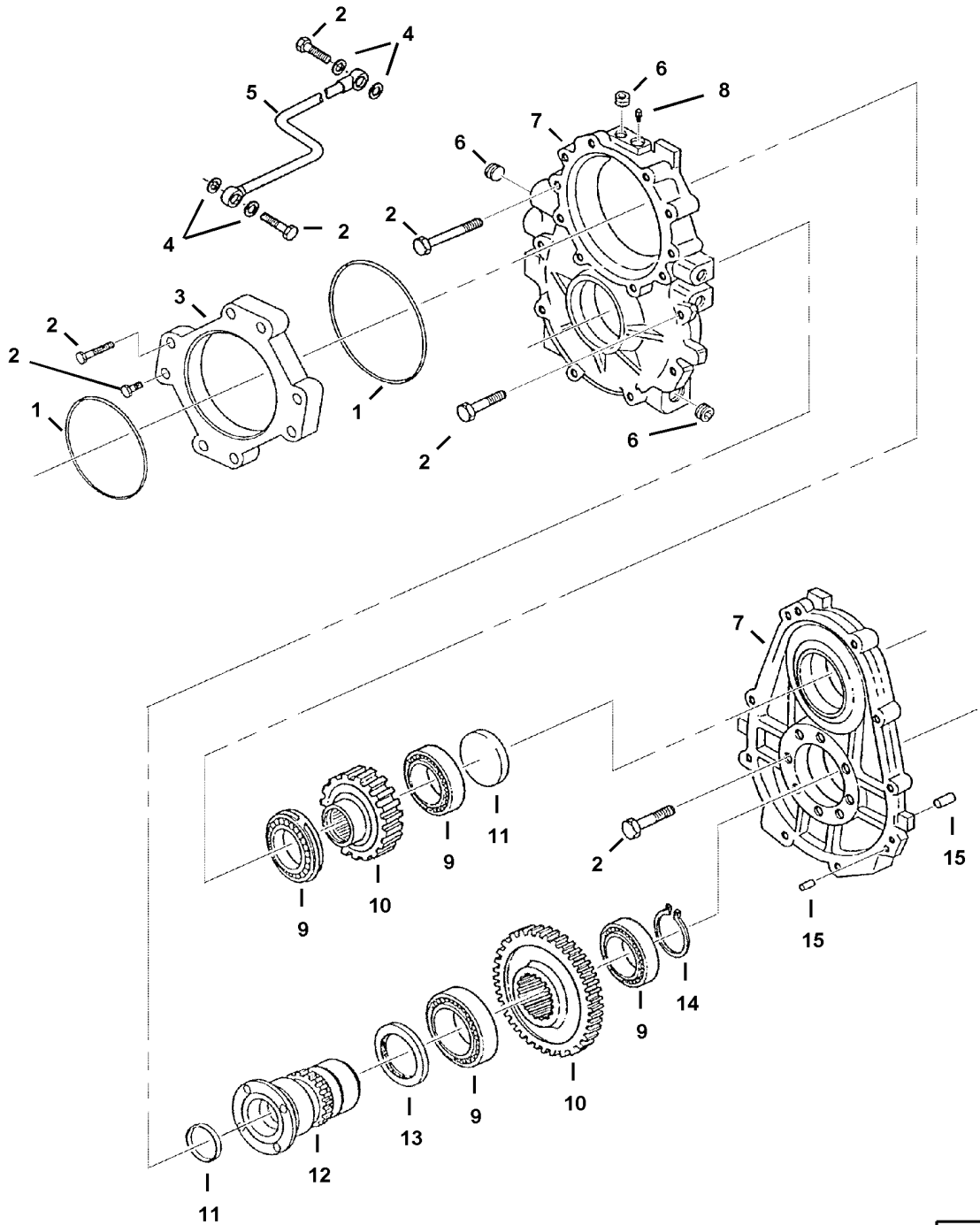

B-15972

DRIVE BOX (For S/N 362811001 - 362812000, S/N 362911001 - 362912000) (CONT'D)

Assembly (Cont'd)

Figure 20-70-33

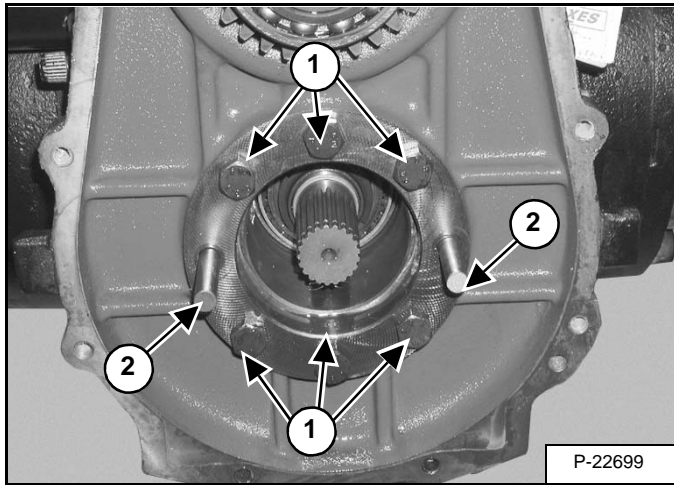

Apply LOCTITE 270 (or equivalent) to the six mounting bolts (Item 1) [Figure 20-70-33] and install. Tighten to 88 ft.-lbs. (120 Nm) torque.

Remove the two guide bolts (Item 2) [Figure 20-70-33].

Figure 20-70-34

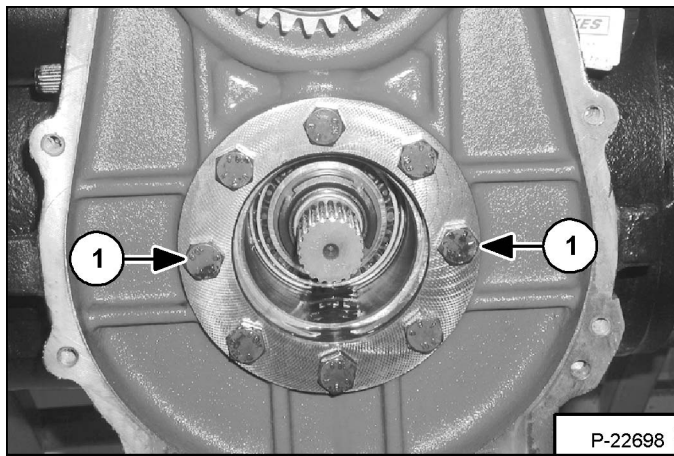

Apply LOCTITE 270 (or equivalent) to the two remaining mounting bolts (Item 1) [Figure 20-70-34]. Install and tighten the bolts to 88 ft.-lbs. (120 Nm) torque.

Figure 20-70-35

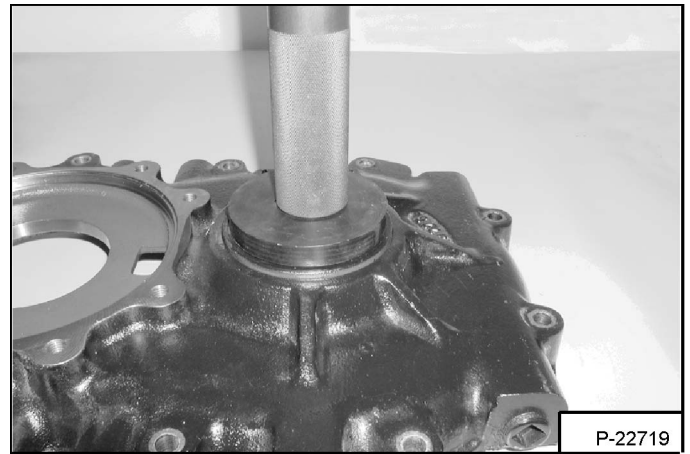

Install the seal (Item 1) [Figure 20-70-35] into the housing.

Figure 20-70-36

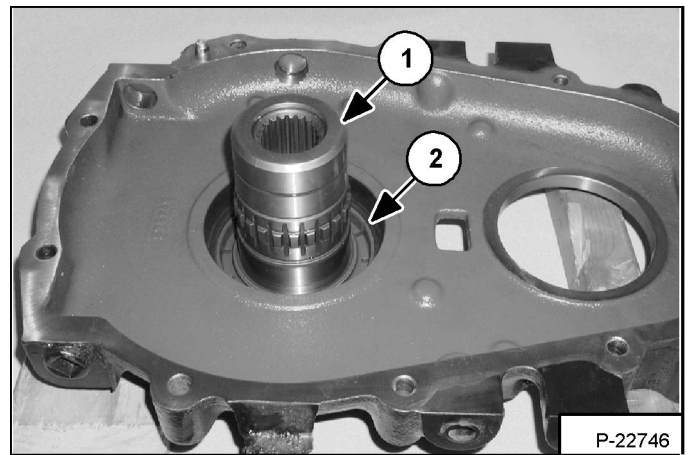

Install the shaft (Item 1) through the seal (Item 2) [Figure 20-70-36] and support the housing with blocks.

DRIVE BOX (For S/N 362812001 and Above, S/N 362912001 and Above) (CONT'D)

Assembly (Cont'd)

Figure 20-71-21

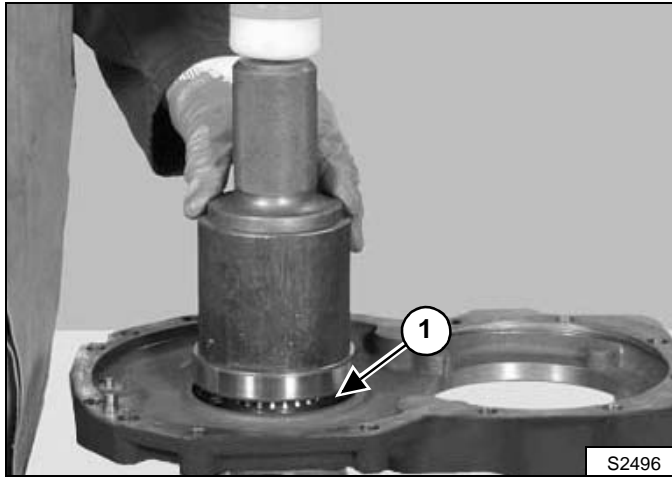

Using a normal tool insert the bearing (Item 1) [Figure 20-71-21] and snap ring.

Figure 20-71-22



Install the secondary gear wheel (Item 1) [Figure 20-71-22] with a plastic hammer.

Figure 20-71-23

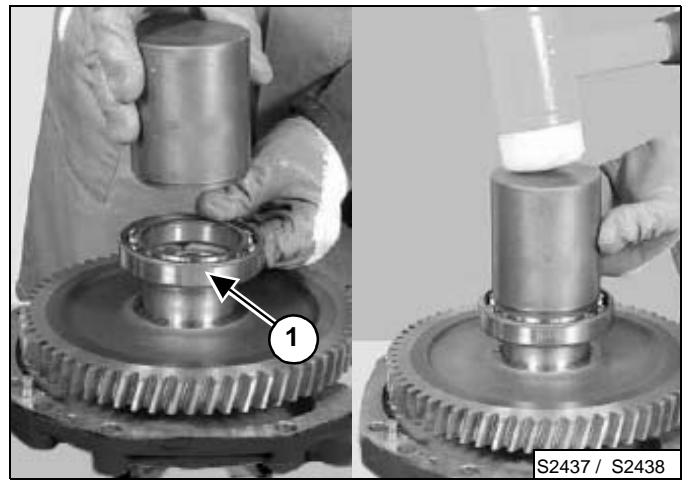

Using a normal tool insert the bearing (Item 1) [Figure 20-71-23].

Figure 20-71-24

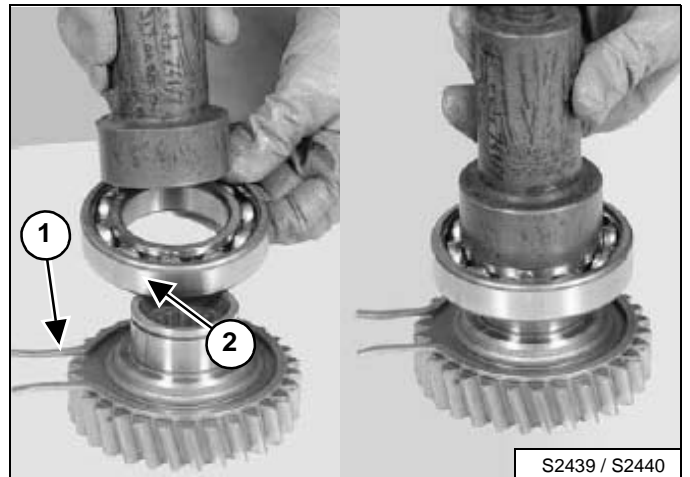

Insert the snap ring (Item 1) and using a normal tool insert the bearing (Item 2) [Figure 20-71-24].

QUICK TACH CYLINDER (CONT'D)

Parts Identification

1. Housing
2. Extension
3. Wiper
4. Seal
5. O-ring
6. Head Gland
7. Rod
8. Piston
9. Wear Ring

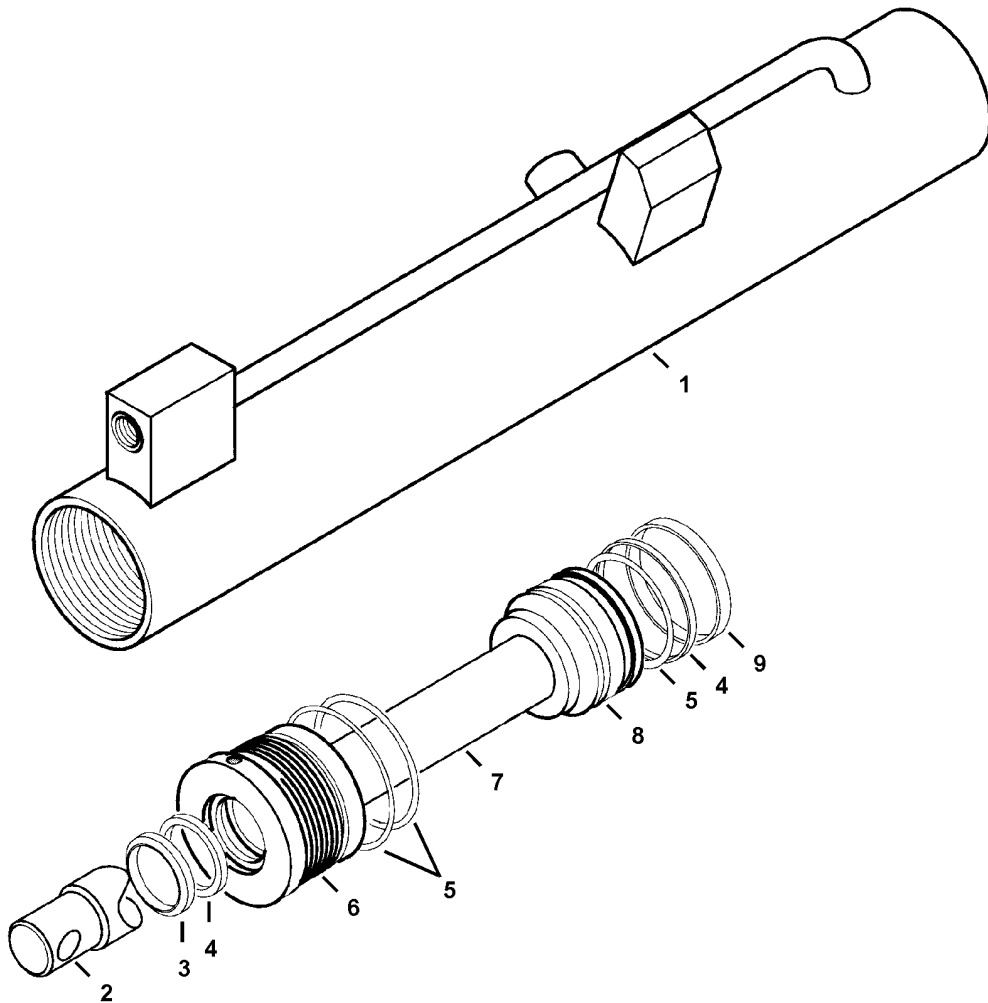

B-16159

FRAME LEVELING CYLINDER (CONT'D)

Disassembly

Use the following tools to disassemble the cylinder:

MEL1353 - Cylinder Gland Nut Wrench

Figure 20-100-5

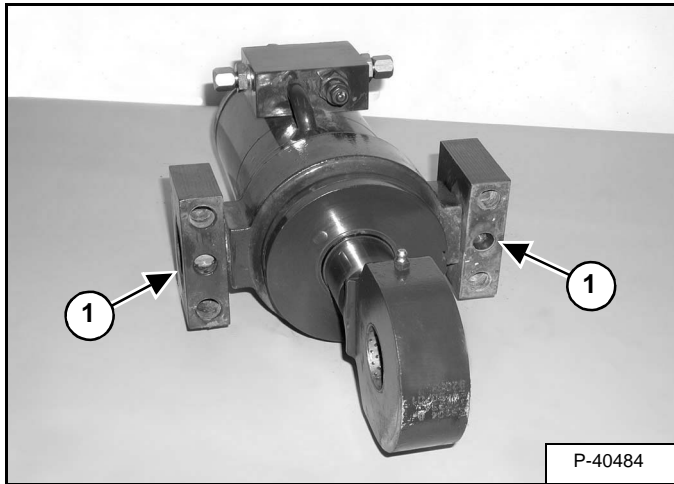

Remove the mounting blocks (item 1) [Figure 20-100-5].

Figure 20-100-6

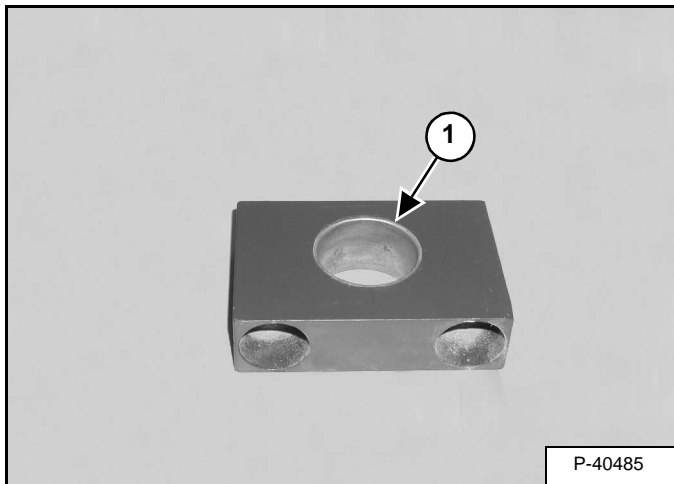

Remove the bushing (item 1) [Figure 20-100-6] from both mounting blocks.

Figure 20-100-7

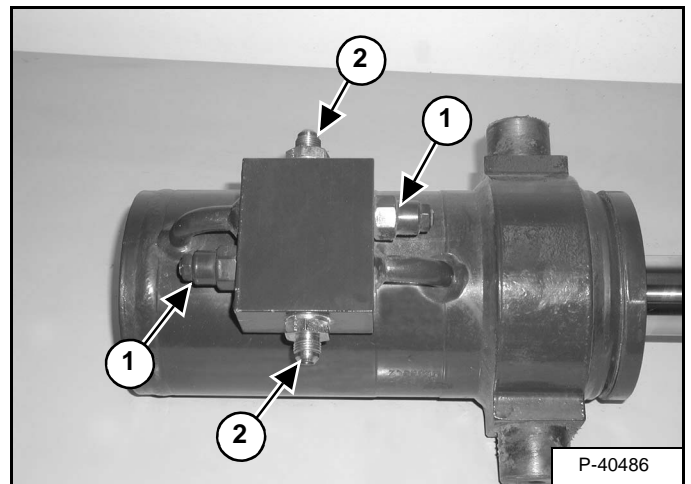

Remove the two relief cartridges (item 1) and two fittings (item 2) [Figure 20-100-7].

Figure 20-100-8

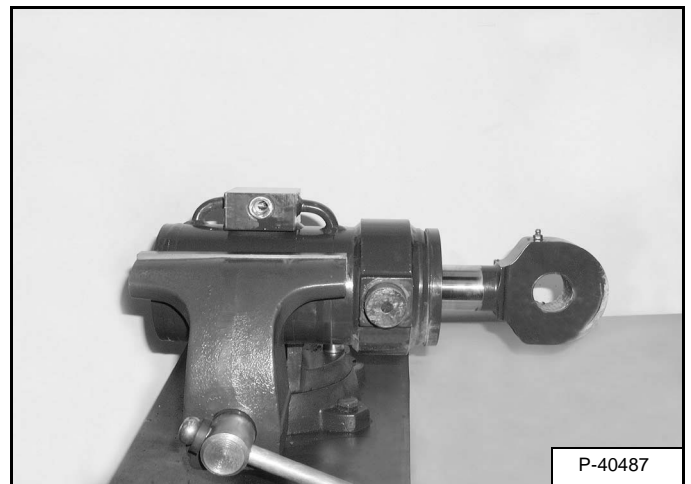

Put the cylinder in a vise [Figure 20-100-8].

FRAME LEVELING CYLINDER (CONT'D)

Assembly (Cont'd)

Figure 20-100-44

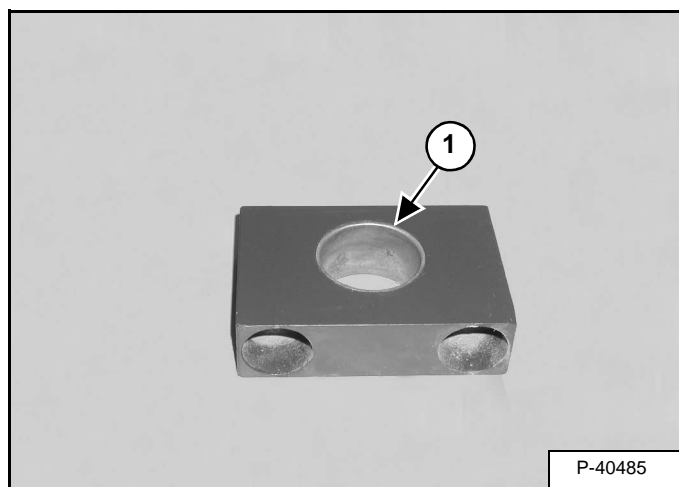

Install the bushing (item 1) [Figure 20-100-44] on both mounting blocks.

Figure 20-100-45

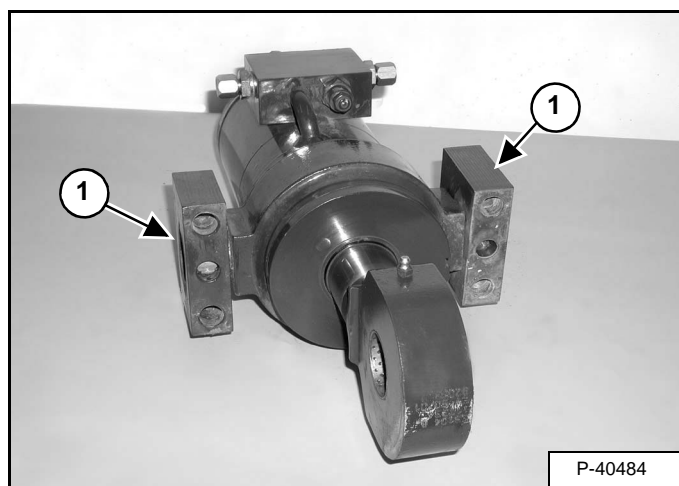

Install the two mounting blocks (item 1) [Figure 20-100-45].

BRAKE VALVE

Removal And Installation

Figure 20-120-1

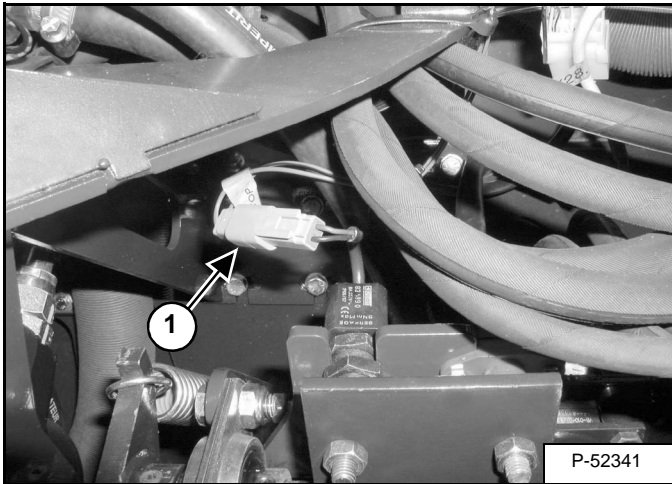

Remove the dash cover/column cover. (See "Removal And Installation" on page 50-130-1.)

Unplug the connector (Item 1) [Figure 20-120-1] from the brake light switch.

Figure 20-120-2

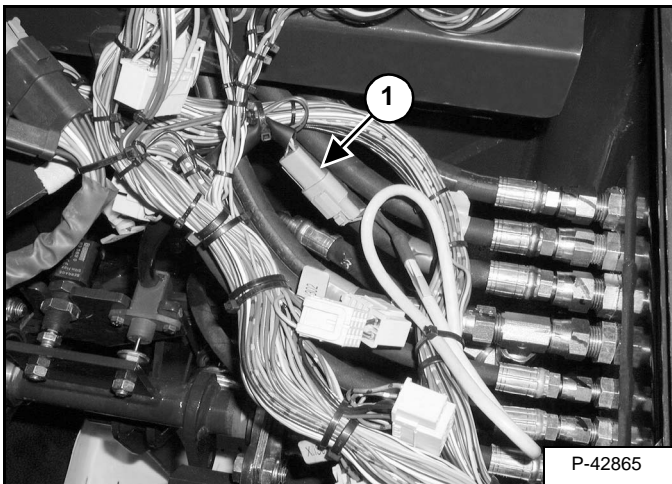

Unplug the connector (Item 1) [Figure 20-120-2] from the inching switch.

Figure 20-120-3

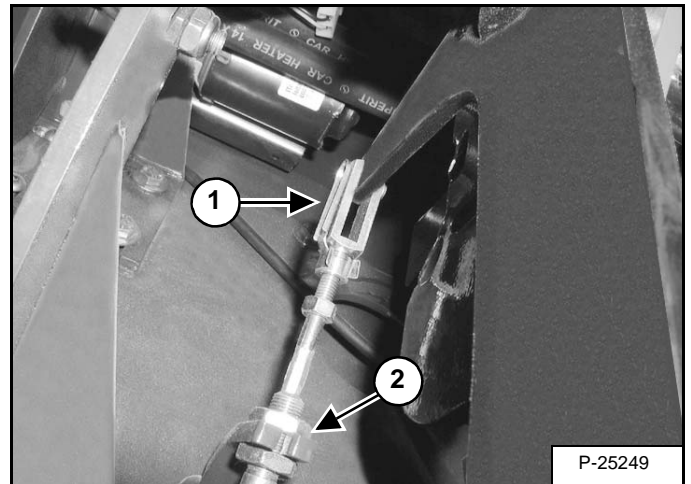

Remove the accelerator cable (Item 1) from the pedal and mounting bracket (Item 2) [Figure 20-120-3].

Figure 20-120-4

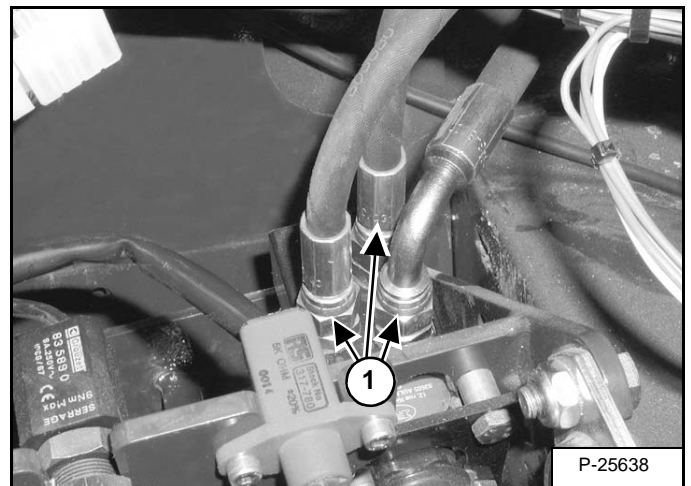

Remove the three hoses (Item 1) [Figure 20-120-4] from the brake valve.

NOTE: Mark hoses for correct installation.

IMPORTANT

When repairing hydrostatic and hydraulic systems, clean the work area before disassembly and keep all parts clean. Always use caps and plugs on hoses, tubelines and ports to keep dirt out. Dirt can quickly damage the system.

I-2003-0888

GEAR PUMP (CONT'D)

Disassembly And Assembly (Cont'd)

Figure 20-130-17

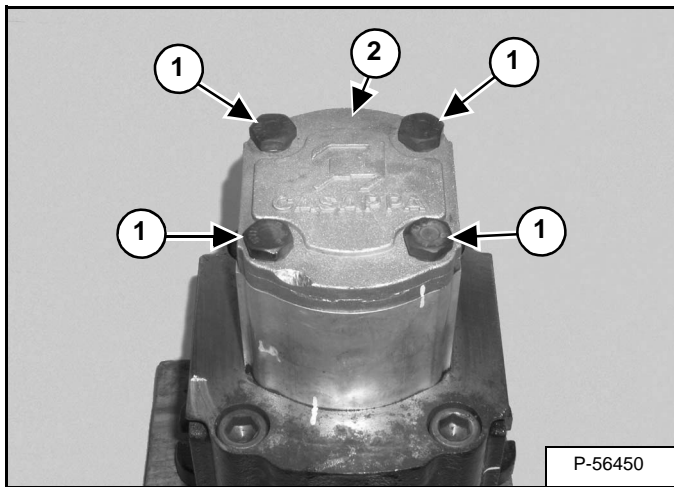

Remove the four bolts (Item 1) and cover (Item 2) [Figure 20-130-17].

Figure 20-130-18

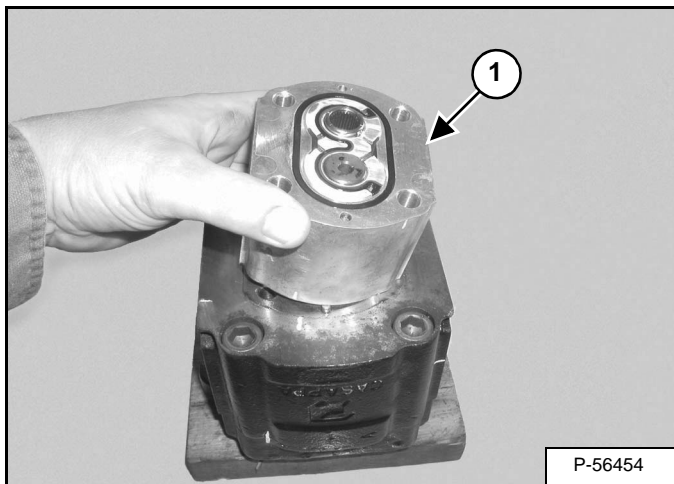

Remove the housing/gear assembly (Item 1) [Figure 20-130-18] from the main housing.

Figure 20-130-19

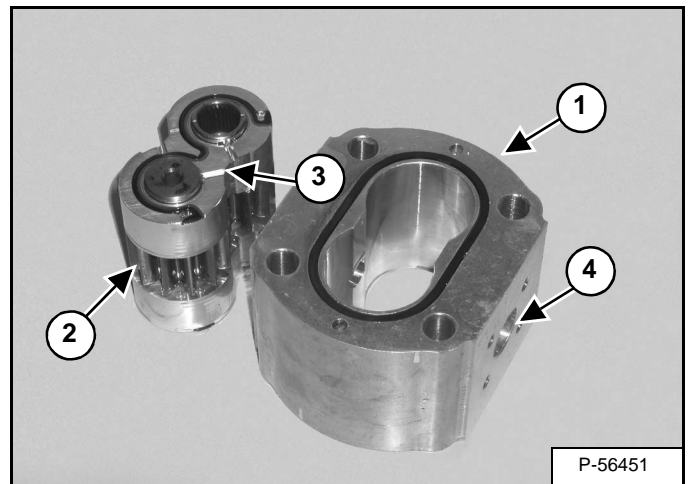

Remove the housing (Item 1) from the gear assembly (Item 2) [Figure 20-130-19].

Assembly: The position of the small opening (Item 3) on the gear holders will point towards the large port (Item 4) [Figure 20-130-19] on the housing.

Figure 20-130-20

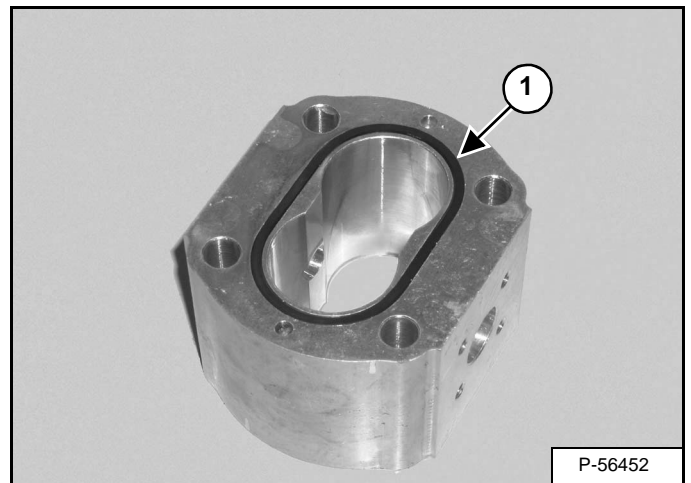

Remove both O-rings (Item 1) [Figure 20-130-20] from the housing.

FAN MOTOR (CONT'D)

Disassembly And Assembly (1 speed version) (Cont'd)

Figure 20-140-17

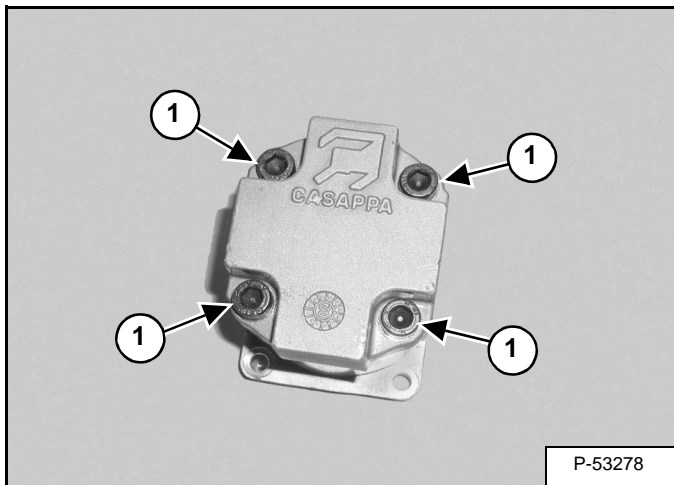

Remove the four bolts (Item 1) [Figure 20-140-17] from the end.

Assembly: Tighten bolts to 32-35 ft.-lbs. (43-47 Nm) torque.

Figure 20-140-18

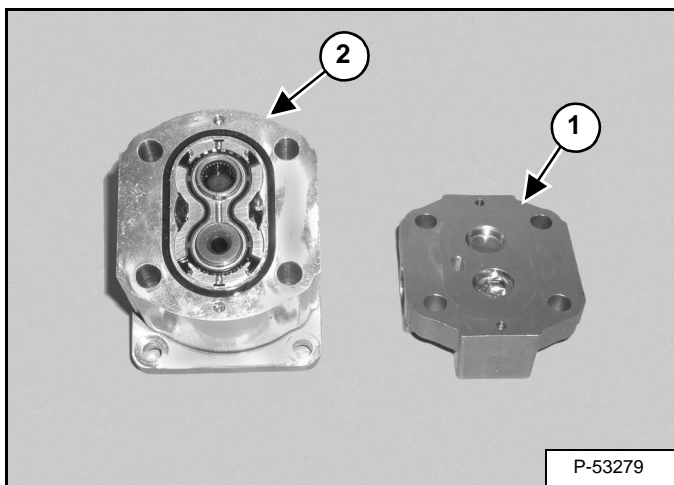

Remove the end cover (Item 1) from the main housing (Item 2) [Figure 20-140-18].

Figure 20-140-19

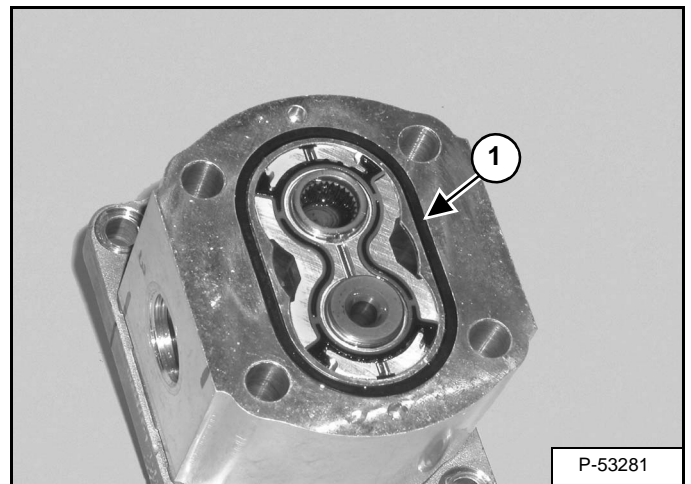

Remove the quad ring (Item 1) [Figure 20-140-19] from the housing.

Figure 20-140-20

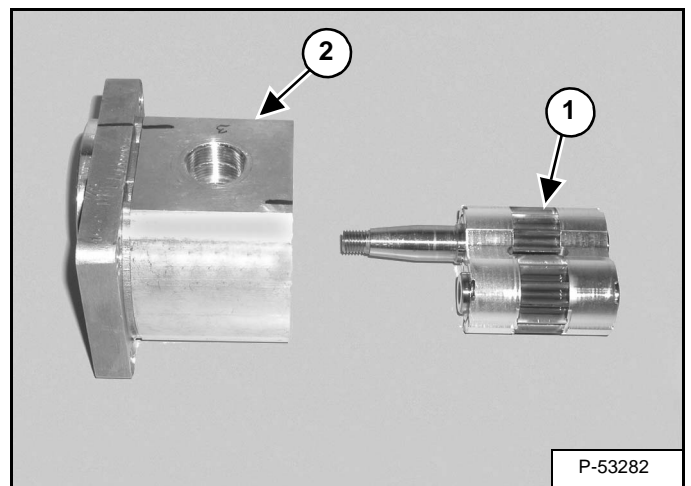

Remove the gear assembly (Item 1) from the housing (Item 2) [Figure 20-140-20].

STEERING VALVE (CONT'D)

Disassembly

IMPORTANT

When repairing hydrostatic and hydraulic systems, clean the work area before disassembly and keep all parts clean. Always use caps and plugs on hoses, tubelines and ports to keep dirt out. Dirt can quickly damage the system.

I-2003-0888

Figure 20-160-3

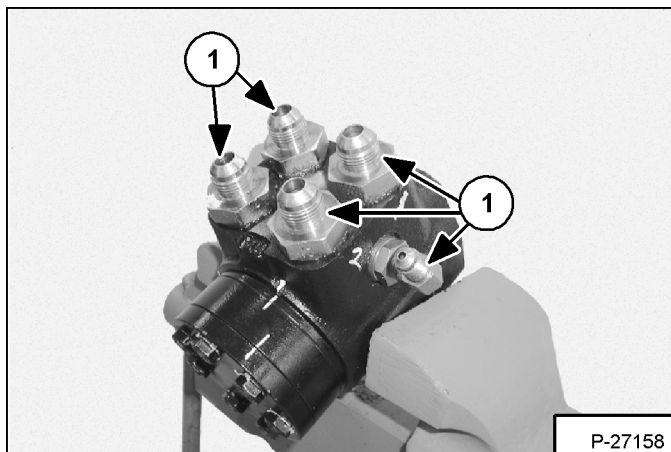

Remove the fittings (Item 1) from the steering valve [Figure 20-160-3].

Figure 20-160-4

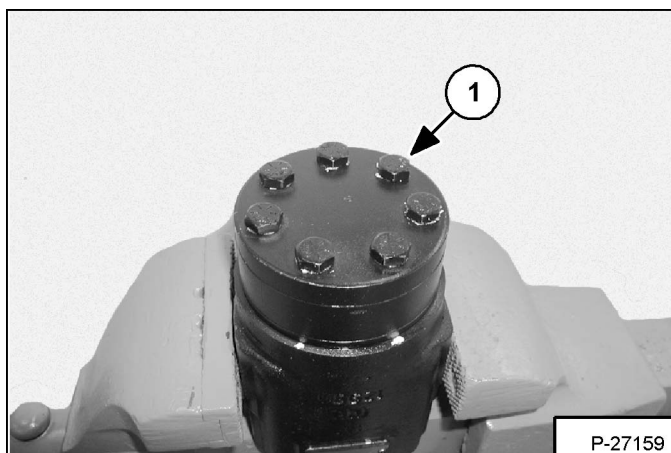

Remove the seven end cap bolts (Item 1) [Figure 20-160-4].

Figure 20-160-5

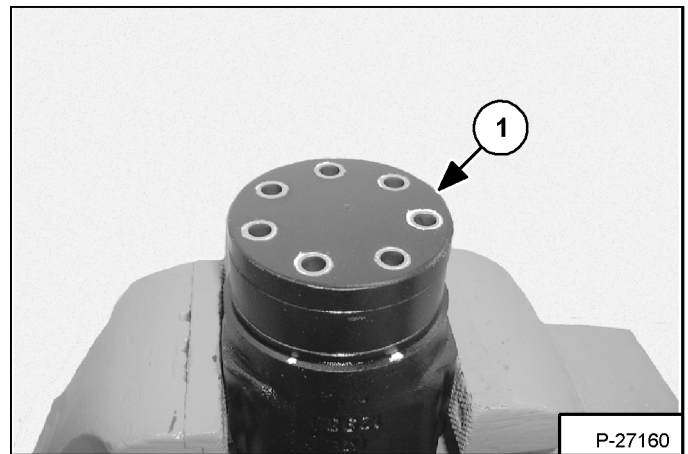

Remove the end cap (Item 1) [Figure 20-160-5].

Figure 20-160-6

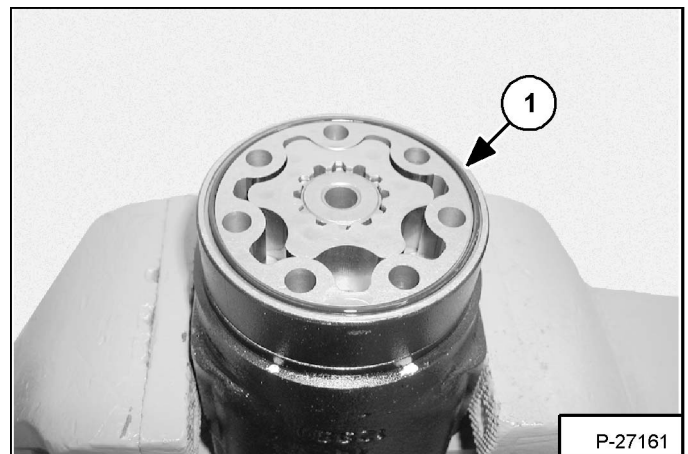

Remove and discard the O-ring (Item 1) [Figure 20-160-6].

Figure 20-160-7

1. Housing
2. Thrust Plate
3. Spacers
4. O-Ring
5. End Cap
6. Nut
7. Mounting Plate
8. Gear Holder
9. Gear

Remove the spacer gear (Item 1) [Figure 20-160-7].

STEERING VALVE (CONT'D)

Assembly (Cont'd)

Figure 20-160-45

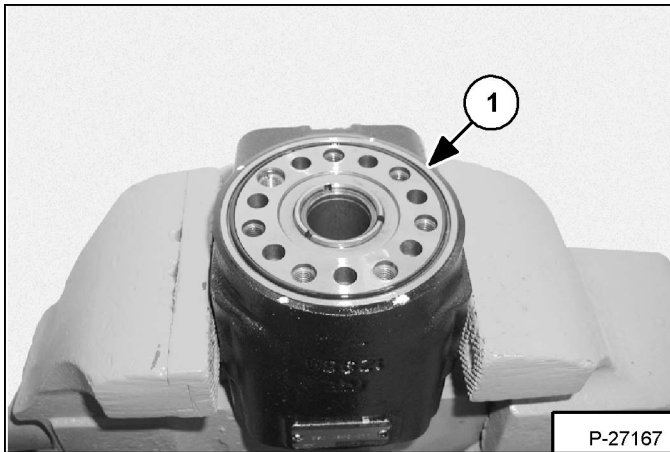

Install a new O-ring (Item 1) [Figure 20-160-45] into the housing groove.

Figure 20-160-46

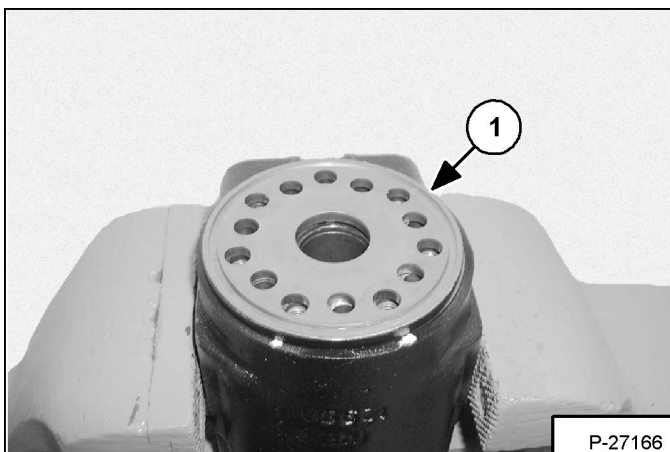

Align and install the 14 hole valve plate (Item 1) [Figure 20-160-46] on the housing.

Figure 20-160-47

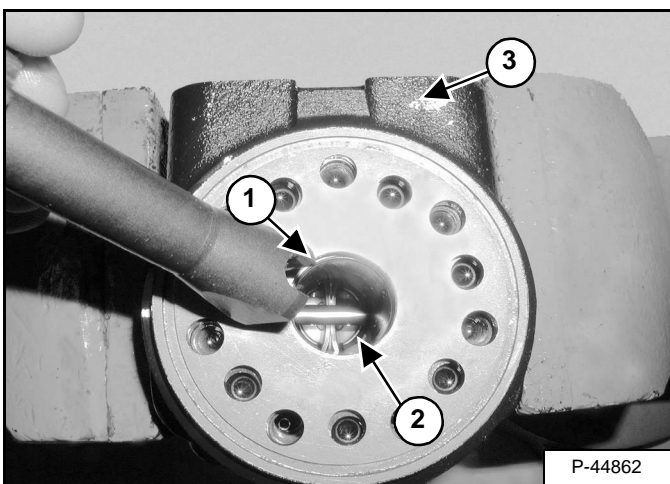

Align the groove (Item 1) in the drive shaft with the drive pin (Item 2) [Figure 20-160-47] and install the drive shaft. Be sure the drive shaft is engaged with the pin.

NOTE: The pin (Item 2) must be parallel with the port face of the housing (Item 3) [Figure 20-160-47].

Figure 20-160-48

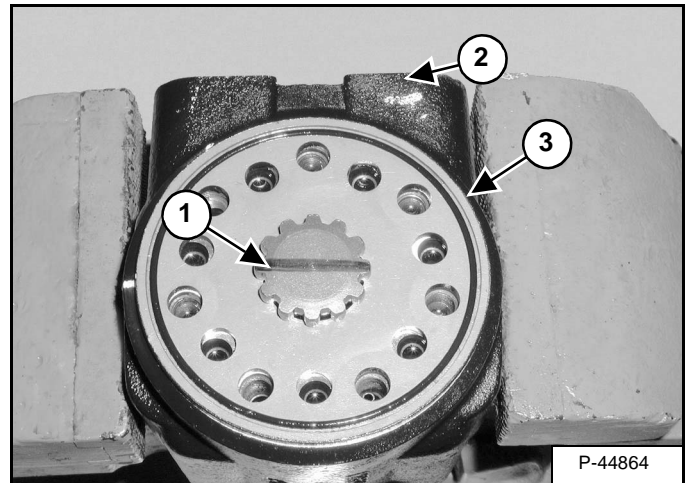

To assure proper geroler alignment, mark the top of the drive shaft (Item 1) (as shown) parallel to the port face (Item 2) [Figure 20-160-48].

Install a new O-ring (Item 3) [Figure 20-160-48] into the valve plate groove.

HYDRAULIC CONTROL VALVE (CONT'D)

Auxiliary Valve Section Troubleshooting (Cont'd)

Figure 20-170-15

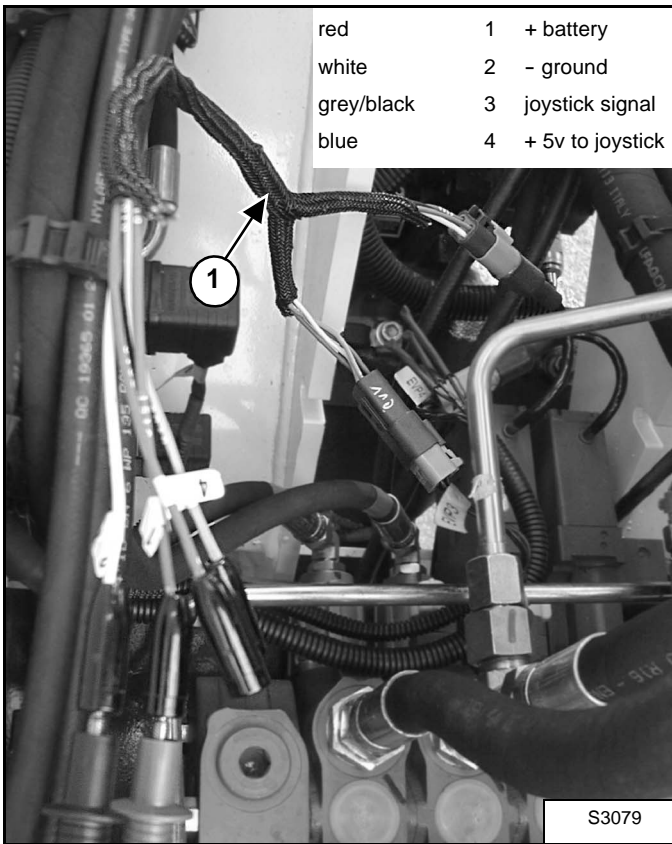
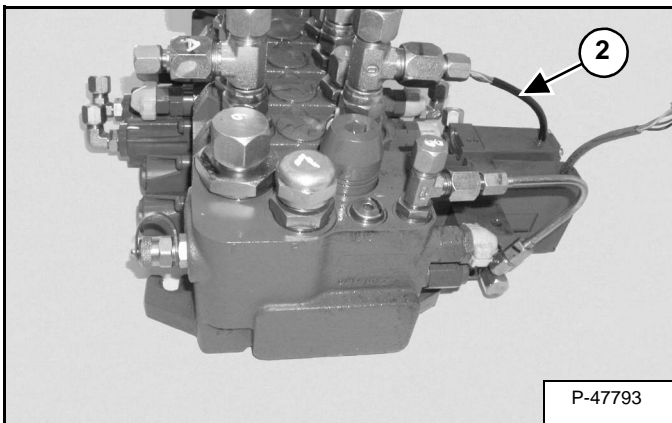

2. A test harness (Item 1) [Figure 20-170-3] (MEL 1609: p/n 6679457) must be installed in between the male and female connector (Item 2) [Figure 20-170-3] of the telescoping valve section.
3. Connect the groundlead (-) of the multimeter to plug 2 (white) of the test harness.
4. With the engine OFF, the key in the run position, check that the battery voltage is at least 12 volts or higher by checking the voltage between plug 2 (white) and plug 1 (red) of the test harness.

5. With the engine OFF, the key in the run position, check that the regulated voltage on the controller connector is 5 volts by checking the voltage between plug 2 (white) and plug 4 (blue) of the test harness.

If 5 volts is not seen, replace the controller.

Figure 20-170-16

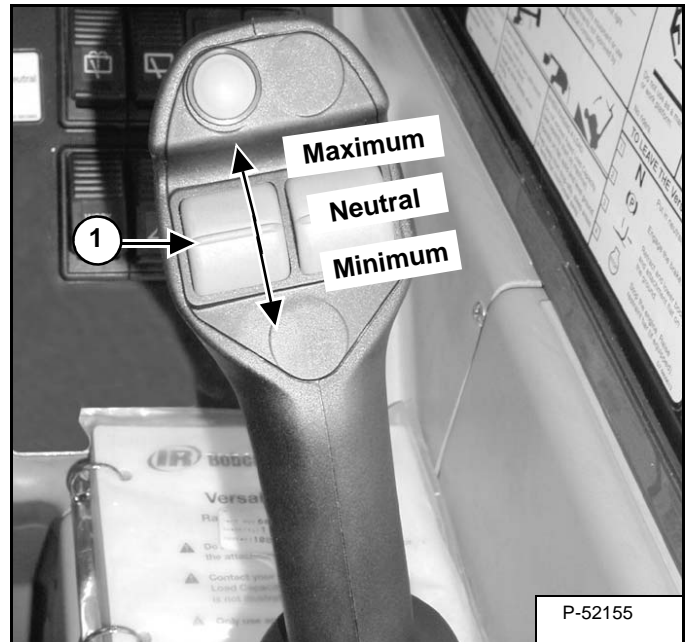

6. With the auxiliary function switch (Item 1) [Figure 20-170-4] in the minimum (back) position check that the voltage between plug 2 (white) and plug 3 (grey/black) of the test harness is 0.9 volts.

If the voltage drops below 0.9 volts the controller will interpret this as a failure.

7. With the auxiliary function switch (Item 1) [Figure 20-170-4] in the neutral (middle) position check that the voltage between plug 2 (white) and plug 3 (grey/black) of the test harness is 2.5 volts.
8. With the auxiliary function switch (Item 1) [Figure 20-170-4] in the maximum (forward) position check that the voltage between plug 2 (white) and plug 3 (grey/black) of the test harness is 4.1 volts.

If one of the three voltage readings in Steps 6, 7 and 8 is not correct, replace the joystick handle. (See "Removal And Installation" on page 20-180-1.)

If all voltage readings in Steps 6, 7 and 8 are correct go to step 9.

HYDRAULIC CONTROL VALVE (CONT'D)

End Housing Disassembly And Assembly

Remove the O-ring (Item 1) [Figure 20-170-42] from the plug..

Figure 20-170-40

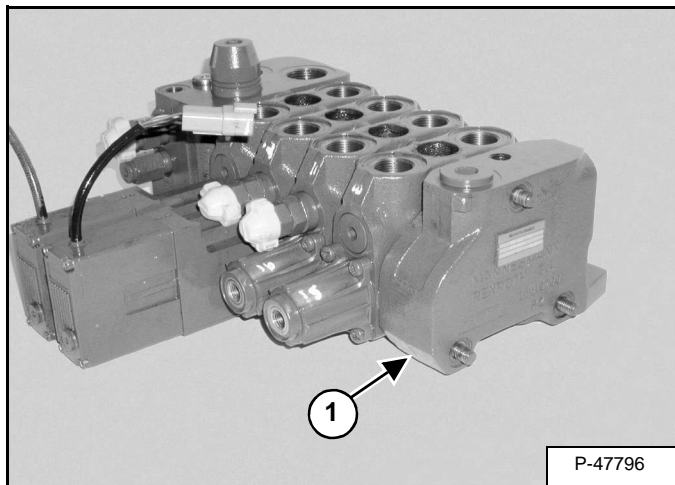

Remove the end housing (Item 1) [Figure 20-170-40].

Figure 20-170-41

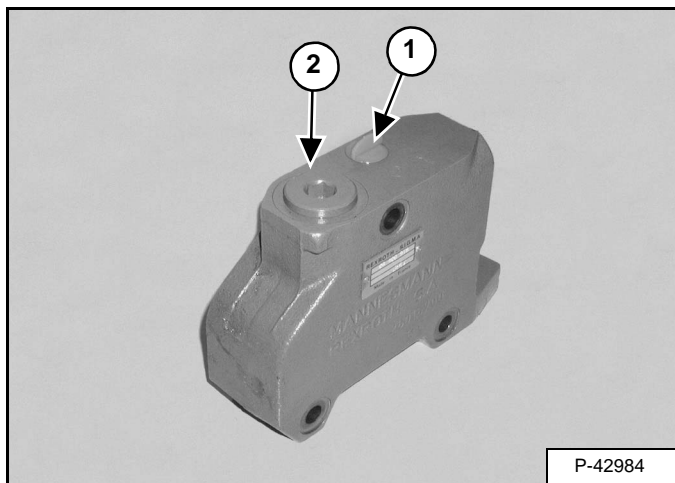

Remove the dust cap (Item 1) and plug (Item 2) [Figure 20-170-41] from the end housing.

Figure 20-170-42

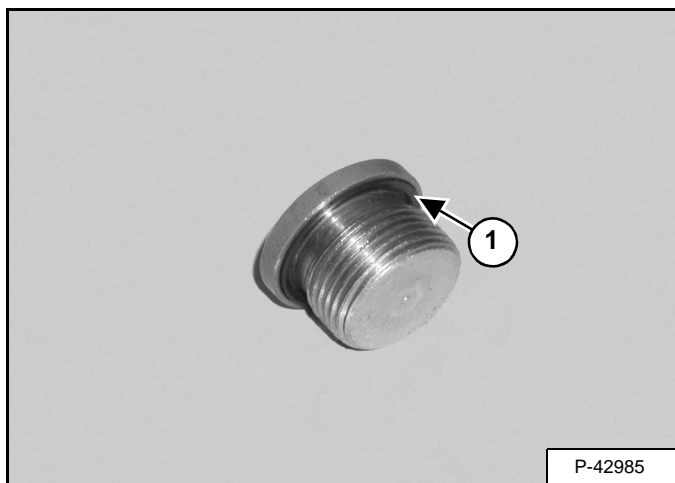

HYDRAULIC CONTROL VALVE (CONT'D)

Tilting Valve Section Disassembly And Assembly (Cont'd)

Figure 20-170-79

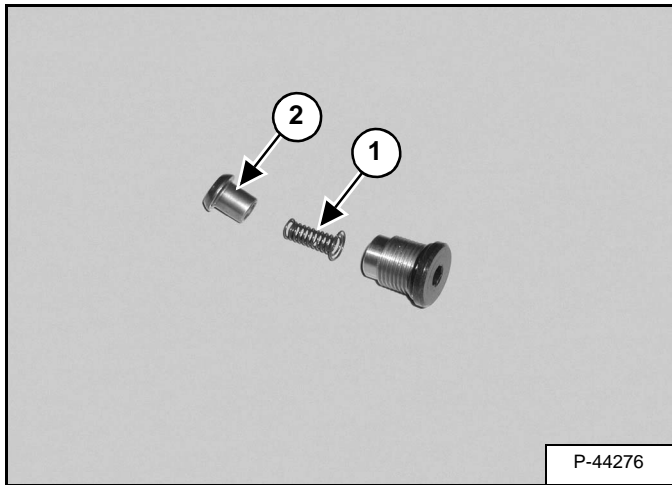

Remove the spring (Item 1) and poppet (Item 2) [Figure 20-170-79] from the plugs.

Figure 20-170-80

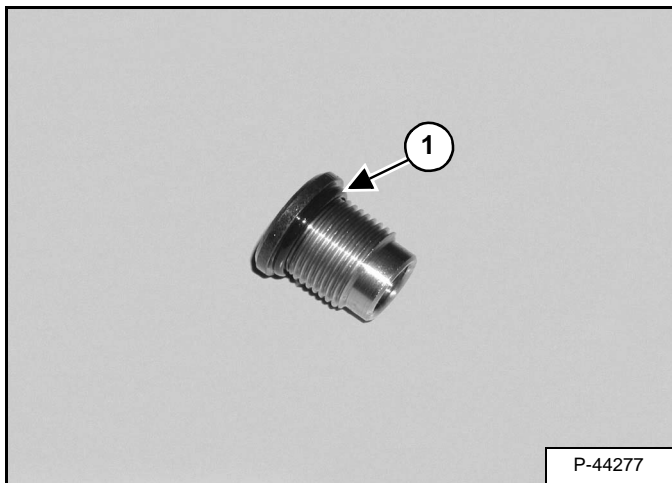

Remove the O-ring (Item 1) [Figure 20-170-80] from the plugs.

Figure 20-170-81

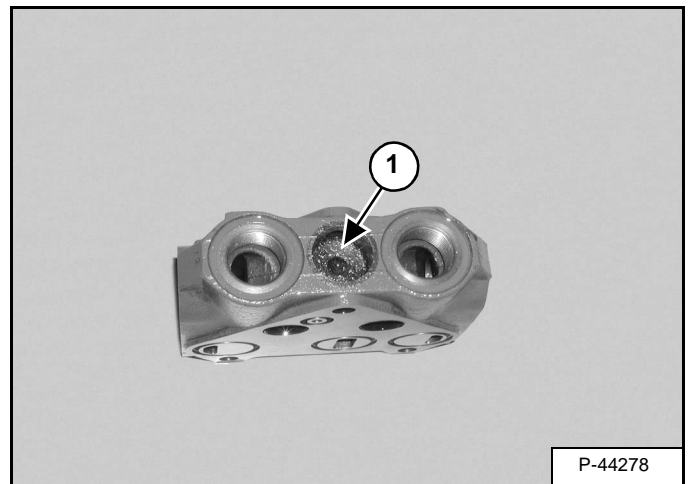

Loosen the plug (Item 1) [Figure 20-170-81].

Assembly: Tighten the plug to 40-49 ft.-lbs. (54-66 Nm) torque.

Figure 20-170-82

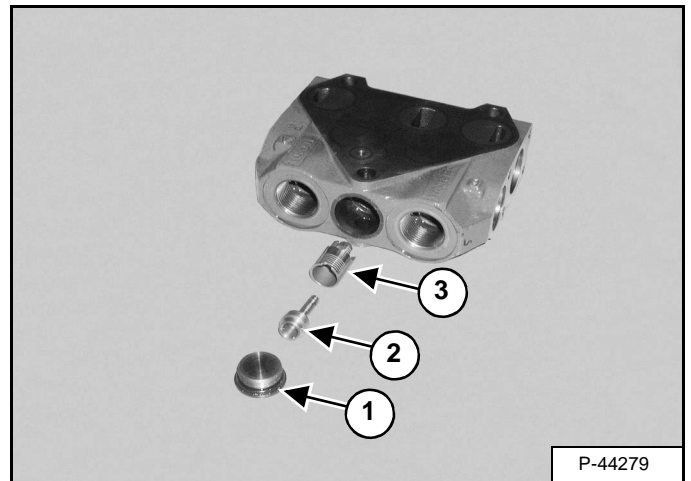

Remove the individual pressure compensator plug (Item 1) poppet (Item 2) and guide (Item 3) [Figure 20-170-82] from the valve section.

HYDRAULIC CONTROL VALVE (CONT'D)

Telescoping Valve Section Disassembly And Assembly (Cont'd)

Figure 20-170-119

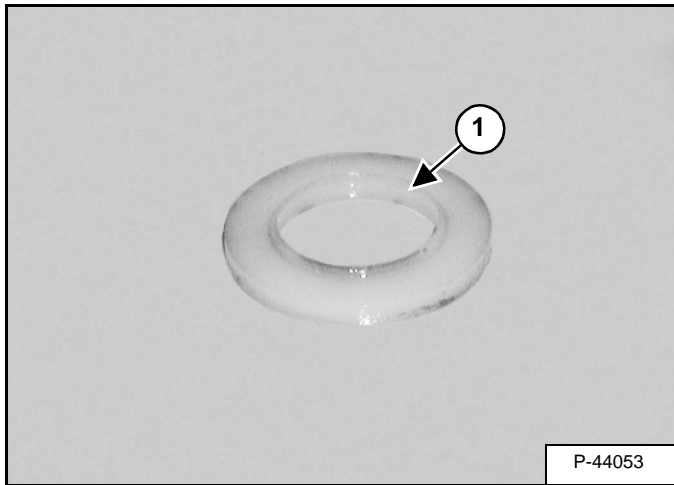

Assembly: The lip on the seal (Item 1) [Figure 20-170-119] fits inside the retainer (Item 3) [Figure 20-170-118].

Figure 20-170-120

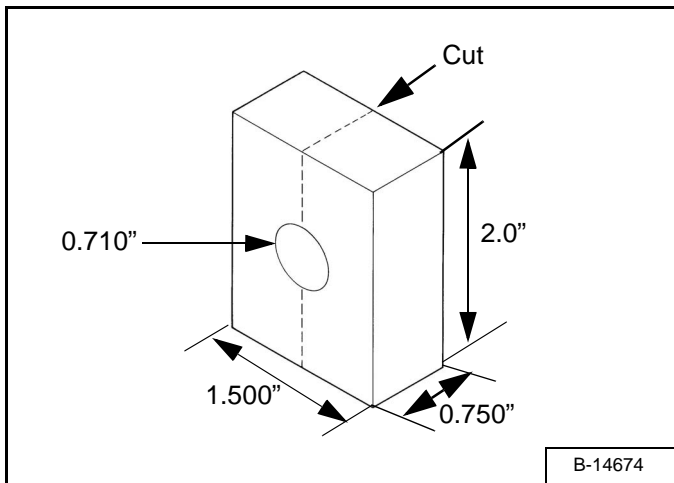

To remove the spring assembly from the spool a holding fixture will have to be made from a .750 inch thick x 1.500 inch wide x 2.0 inch long (19 mm thick x 38 mm wide x 51 mm long) piece of hardwood. Drill a 0.710 inch (18 mm) hole in the center of the hardwood block. Cut the block lengthwise [Figure 20-170-120].

Figure 20-170-121

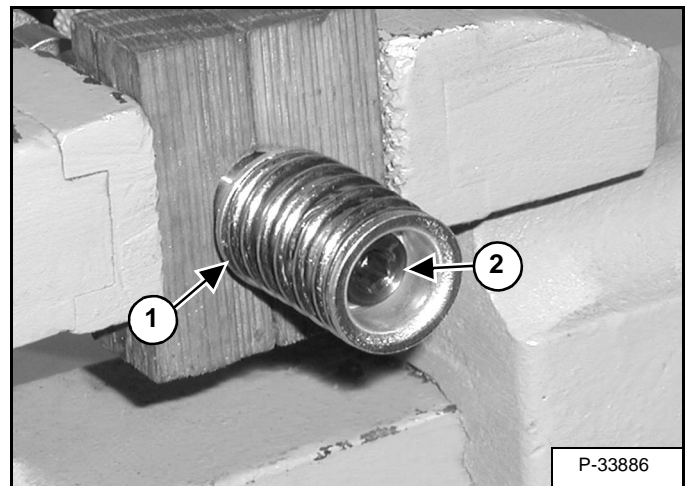

Using the wood blocks clamp the spool (Item 1) [Figure 20-170-121] in a vise.

NOTE: Do not use anything other than hardwood blocks to grip the spool, or the spool will be damaged.

Loosen the screw (Item 2) [Figure 20-170-121].

Assembly: Tighten the screw to 7 ft.-lbs. (10 Nm) torque.

Figure 20-170-122

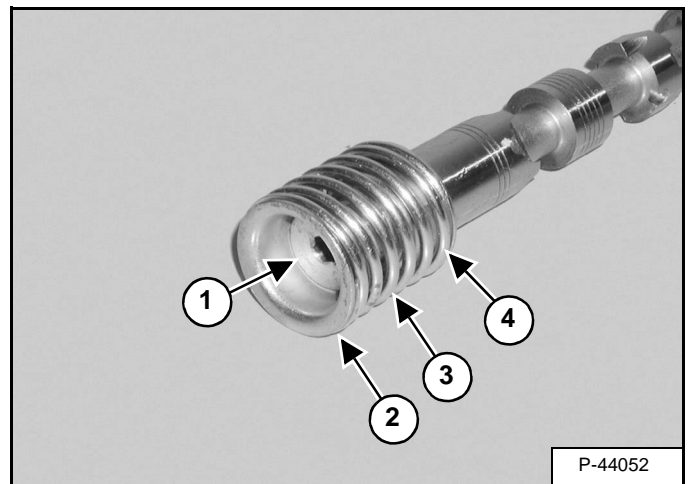

Remove the screw (Item 1), spring retainer (Item 2), spring (Item 3) and spring retainer (Item 4) [Figure 20-170-122] from the spool.

HYDRAULIC CONTROL VALVE (CONT'D)

Auxiliary/Frame Leveling Valve Section Disassembly And Assembly (Cont'd)

Figure 20-170-156

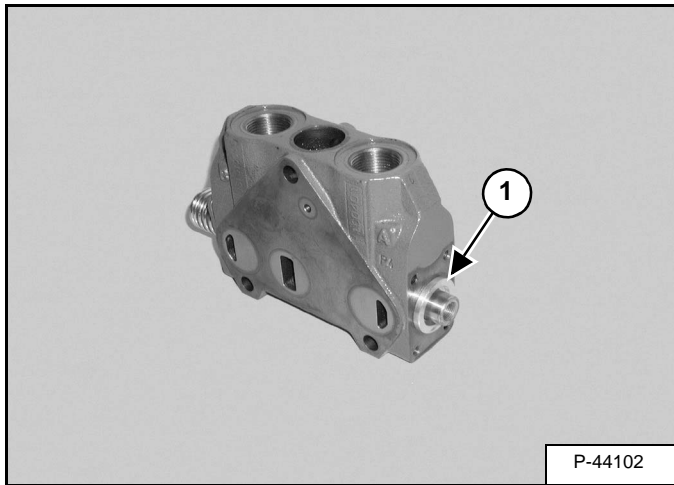

Remove the washer (Item 1) [Figure 20-170-156] from the valve section.

Figure 20-170-157

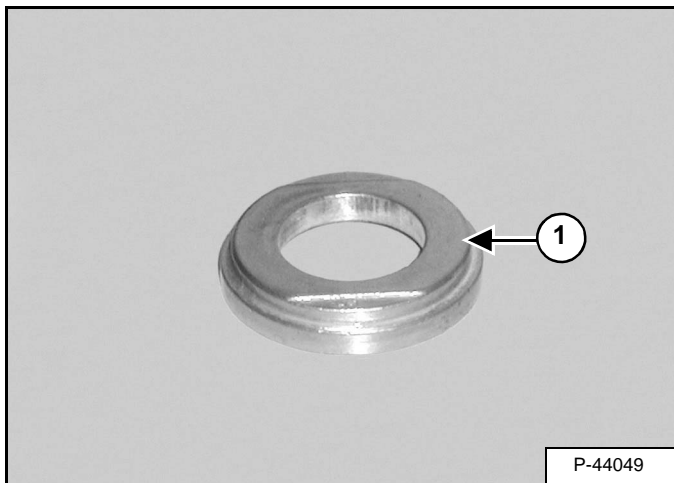

Assembly: Install the countersunk side of the washer (Item 1) [Figure 20-170-157] into the valve section.

Figure 20-170-158

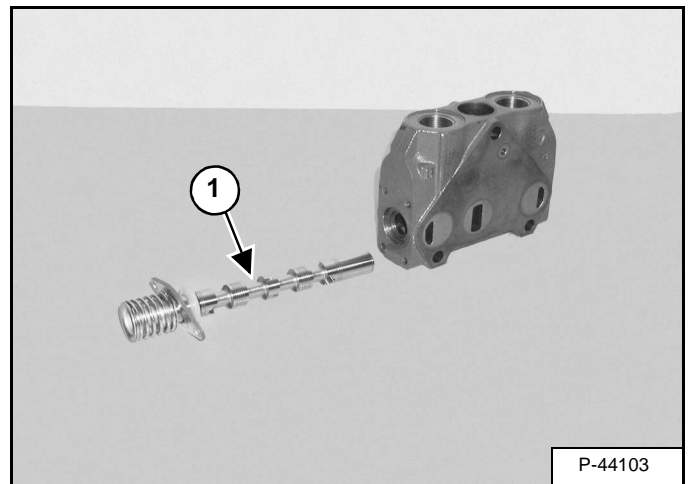

Remove the spool (Item 1) [Figure 20-170-158] from the valve section.

NOTE: When the spool is removed, use care not to scratch the spool surface and do not interchange spools and valve blocks.

Figure 20-170-159

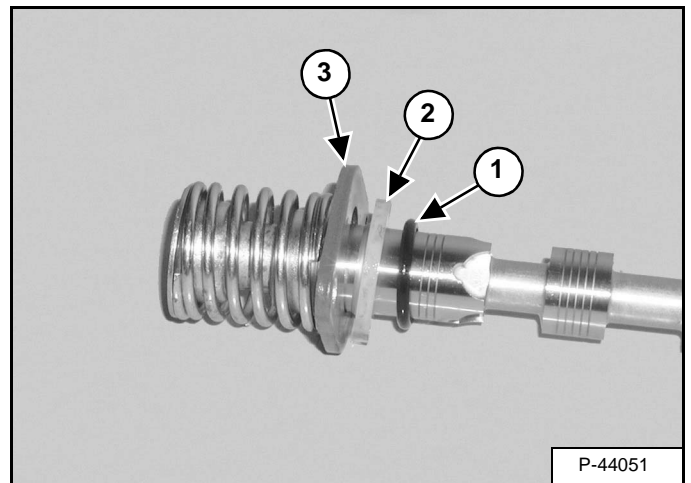

Remove the O-ring (Item 1), seal (Item 2) and retainer (Item 3) [Figure 20-170-159] from the spool.

FLOW CONTROL VALVE

Removal And Installation

Figure 20-172-1

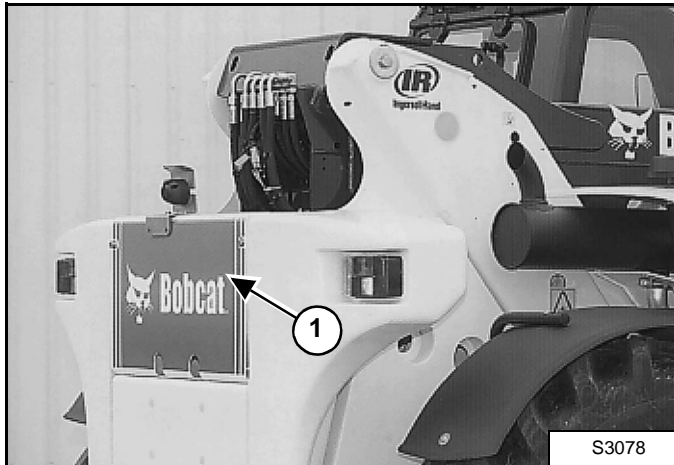

Remove the rear cover (Item 1) [Figure 20-172-1].

Figure 20-172-2

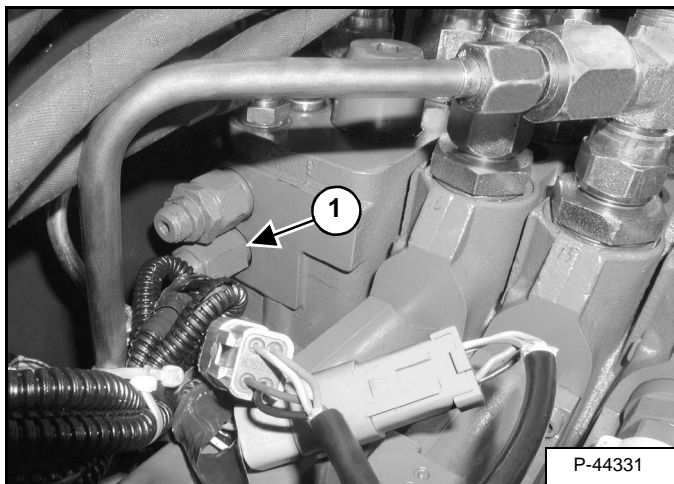

Remove the flow control valve (Item 1) [Figure 20-172-2] from the right front of the hydraulic control valve.

Installation: Tighten the flow control valve to 15 ft.-lbs. (20 Nm) torque..

Figure 20-172-3

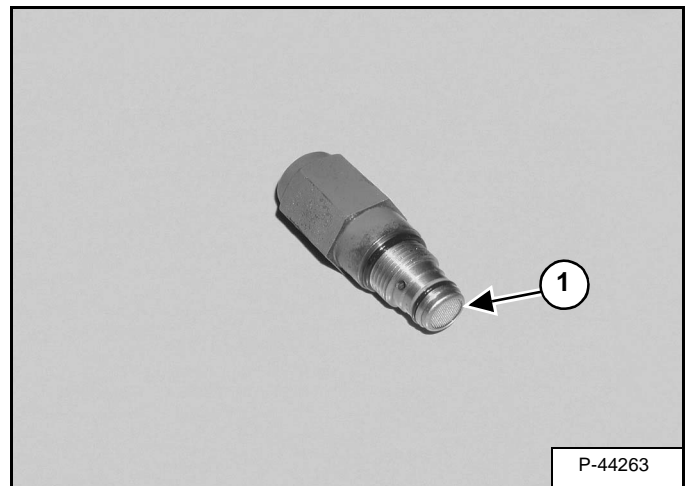

Remove and clean the filter (Item 1) [Figure 20-172-3].

NOTE: Check the filter for any damage. Replace the filter if required.

PILOT PRESSURE LOCK OUT VALVE (CONT'D)

Removal And Installation (Cont'd)

Figure 20-200-7

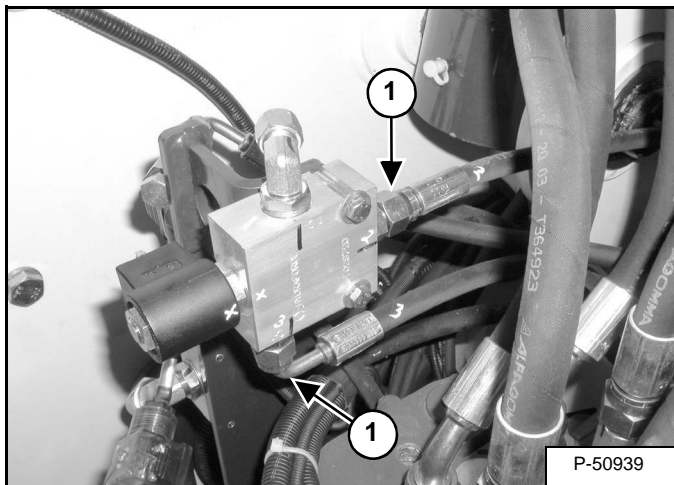

Remove the two hoses (Item 1) [Figure 20-200-7].

Figure 20-200-8

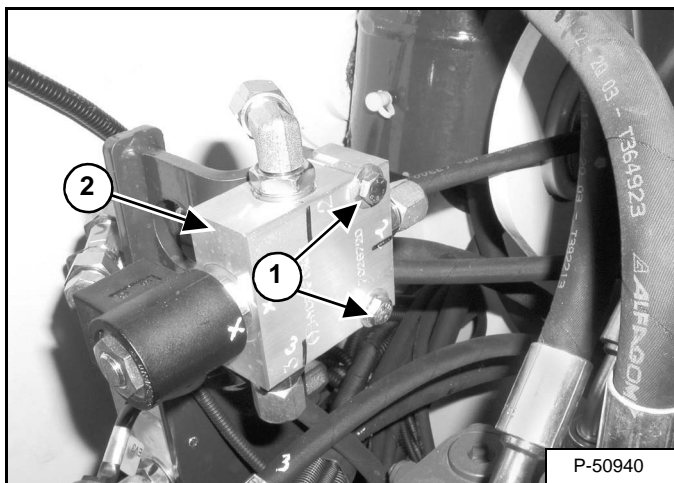

Remove the two mounting bolts (Item 1) and remove the pilot pressure lock out valve (Item 2) [Figure 20-200-8].

Disassembly And Assembly

Figure 20-200-9

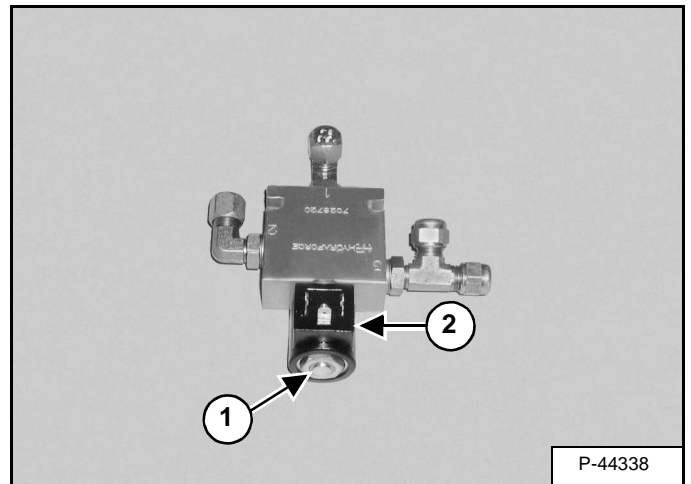

Remove the nut (Item 1) and coil (Item 2) [Figure 20-200-9] from the spool.

Figure 20-200-10

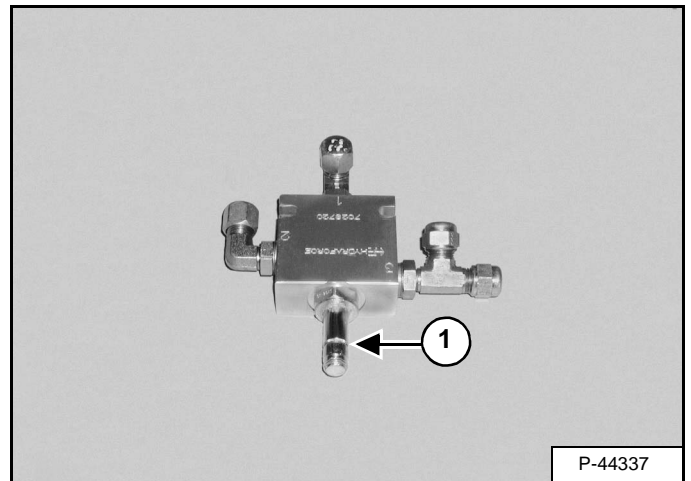

Remove the spool (Item 1) [Figure 20-200-10].

HYDROSTATIC SYSTEM

HYDROSTATIC DRIVE MOTOR	30-30-1
Assembly	30-30-22
Disassembly	30-30-5
Inspection	30-30-20
Parts Identification	30-30-2
Removal And Installation	30-30-1
HYDROSTATIC PUMP	30-40-1
Assembly	30-40-25
CHARGE PRESSURE CHECKING PROCEDURE	30-40-40
CHARGE PRESSURE ADJUSTING PROCEDURE	30-40-40
Disassembly	30-40-9
Inspection	30-40-21
Parts Identification	30-40-4
Removal And Installation	30-40-1
HYDROSTATIC SYSTEM INFORMATION	30-10-1
Replenishing Valve Function	30-10-2
Troubleshooting Chart	30-10-1
OIL COOLER	30-20-1
Description	30-20-1

**HYDROSTATIC
SYSTEM**

HYDROSTATIC DRIVE MOTOR (CONT'D)

Disassembly

IMPORTANT

When repairing hydrostatic and hydraulic systems, clean the work area before disassembly and keep all parts clean. Always use caps and plugs on hoses, tubelines and ports to keep dirt out. Dirt can quickly damage the system.

I-2003-0888

Figure 30-30-2

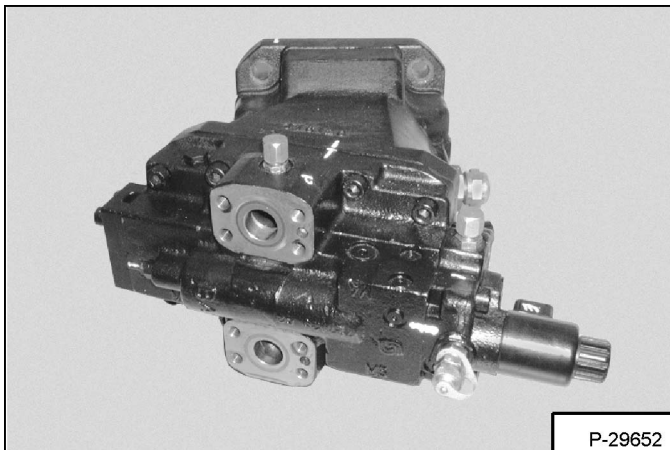

Place the hydrostatic drive motor on a work surface, mark the sections for correct assembly [Figure 30-30-2].

Figure 30-30-3

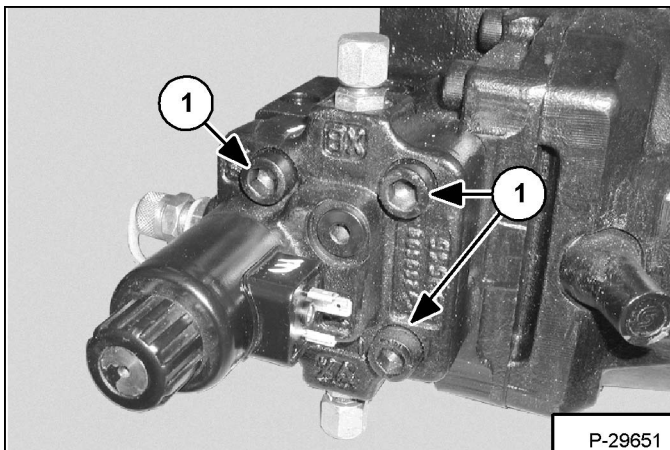

Remove the four bolts (Item 1) [Figure 30-30-3] and remove the solenoid housing.

Figure 30-30-4

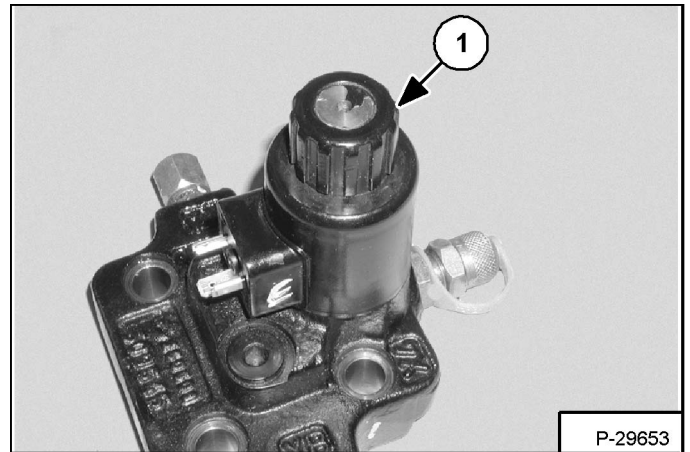

Remove the solenoid nut (Item 1) [Figure 30-30-4].

Figure 30-30-5

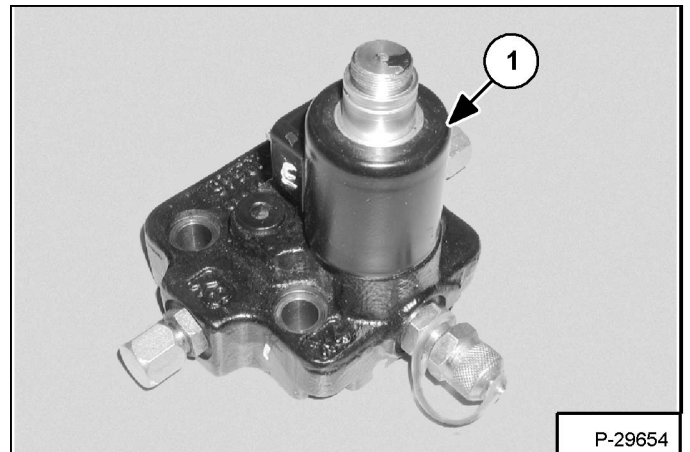

Remove the solenoid (Item 1) [Figure 30-30-5] from the shaft.

HYDROSTATIC DRIVE MOTOR (CONT'D)

Disassembly (Cont'd)

Figure 30-30-42

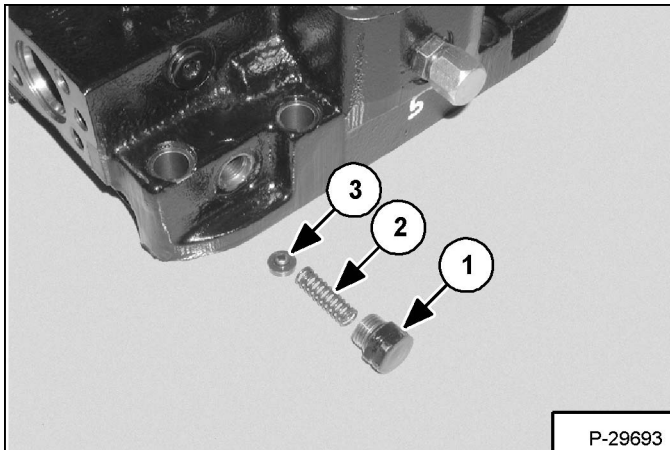

Remove the plug (Item 1), spring (Item 2) and spring seat (Item 3) [Figure 30-30-42] from the housing.

Figure 30-30-43

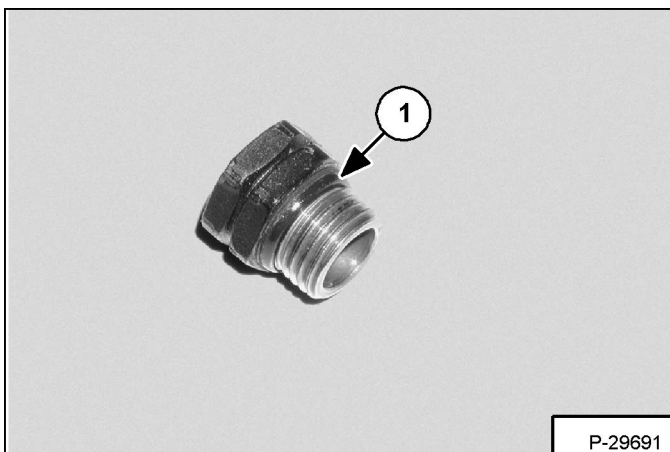

Remove and discard the O-ring (Item 1) [Figure 30-30-43] from the plug.

Figure 30-30-44

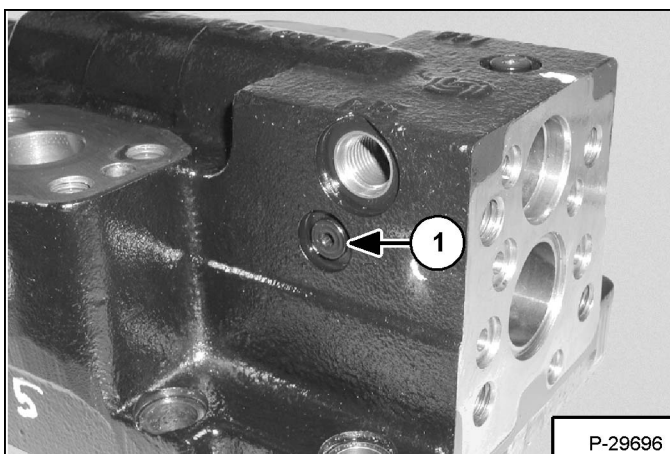

Remove the plug (Item 1) [Figure 30-30-44].

Figure 30-30-45

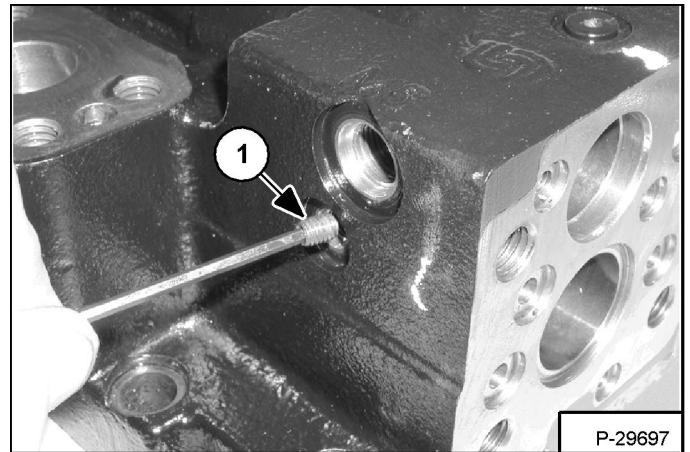

Remove the orifice (Item 1) [Figure 30-30-45].

NOTE: Mark the location of the orifice for correct assembly.

HYDROSTATIC DRIVE MOTOR (CONT'D)

Assembly (Cont'd)

Figure 30-30-80

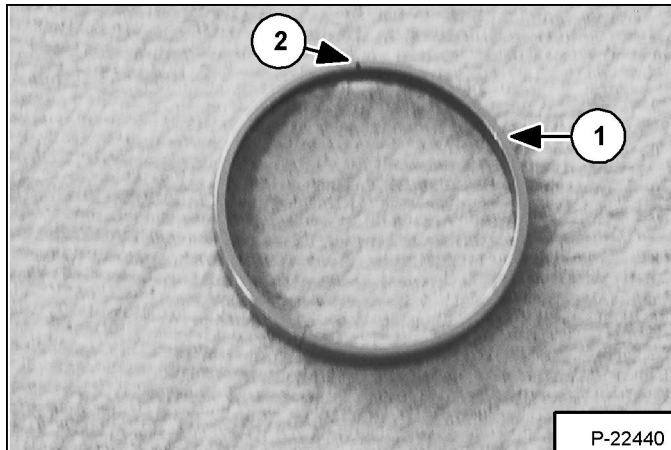
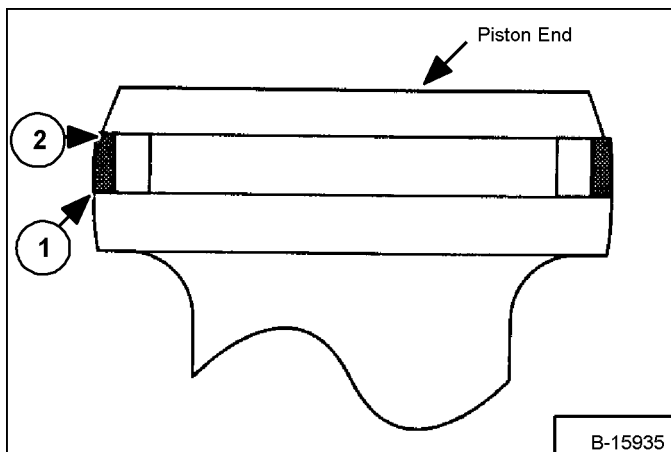

Figure 30-30-81



Install new piston rings (Item 1) [Figure 30-30-80] onto the pistons, make sure the spherical surface (Item 1) [Figure 30-30-81] conforms to the shape of the piston.

An identification mark (Item 2) [Figure 30-30-80] & [Figure 30-30-81] is on the "outer" side of the piston ring.

The ends of the piston rings must NOT overlap each other.

Figure 30-30-82

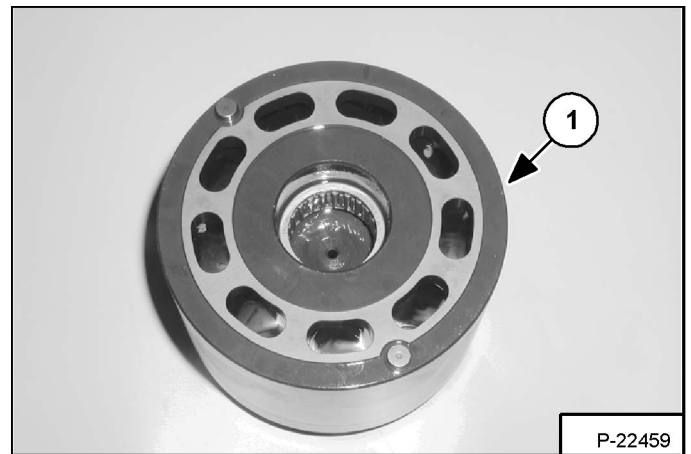

Install the bearing plate (Item 1) [Figure 30-30-82] with the bronze surface facing up onto the cylinder block.

Figure 30-30-83

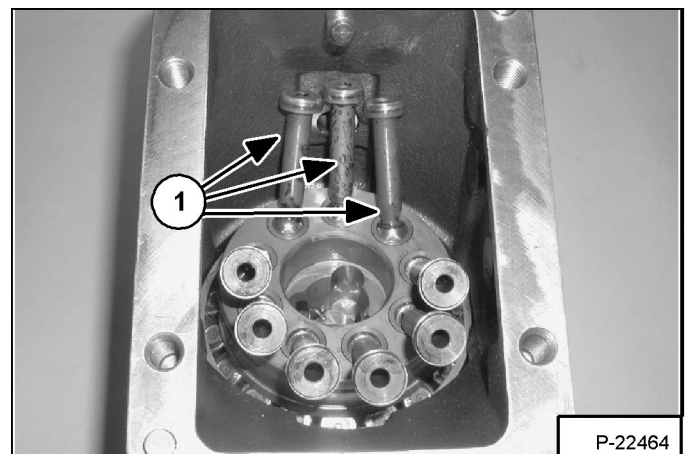

Position the housing on end, tip the three pistons (Item 1) [Figure 30-30-83] closest to the minimum angle stop out toward the housing.

HYDROSTATIC DRIVE MOTOR (CONT'D)

Assembly (Cont'd)

Figure 30-30-120

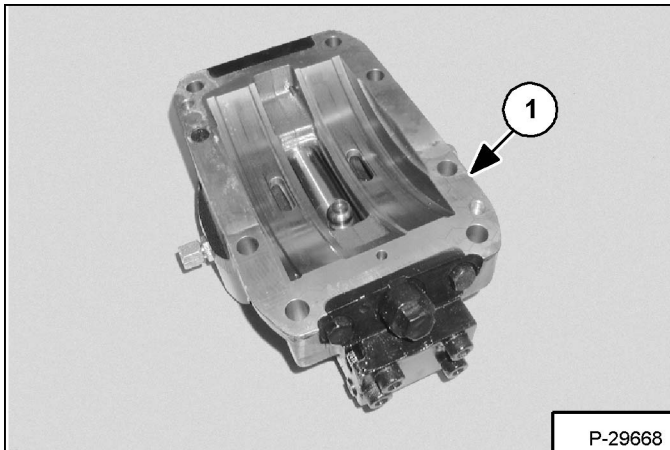

Install a new gasket (Item 1) [Figure 30-30-120] onto the end cap.

Figure 30-30-121

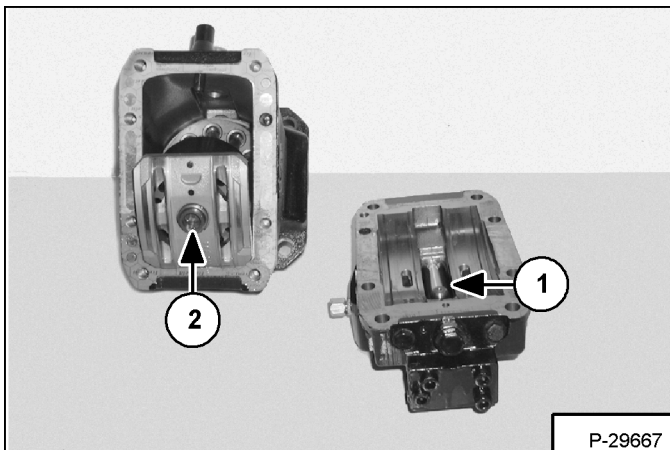

Align the feed back lug (Item 1) and the valve segment (Item 2) [Figure 30-30-121].

Figure 30-30-122

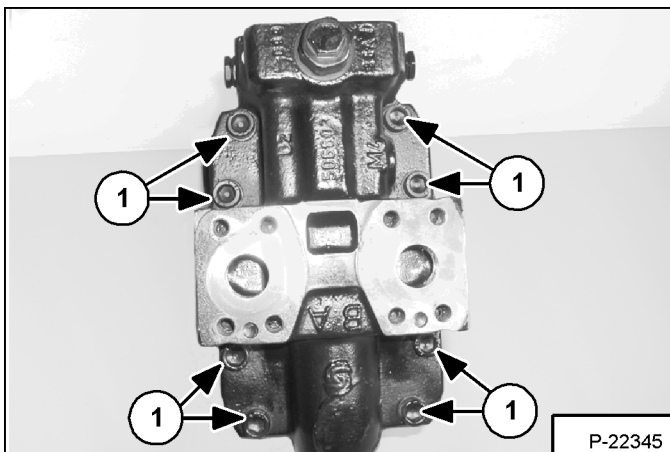

Install the end cap housing and tighten the eight bolts (Item 1) [Figure 30-30-122] to 85 ft.-lbs. (115 Nm) torque.

Figure 30-30-123

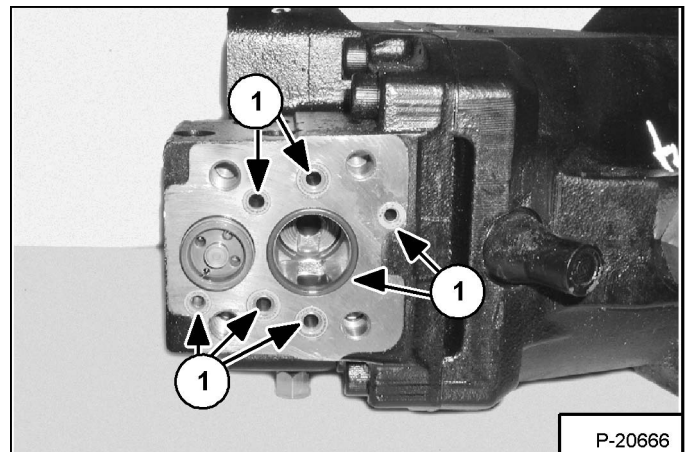

Install the seven O-rings (Item 1) [Figure 30-30-123].

HYDROSTATIC PUMP (CONT'D)

Parts Identification (Cont'd)

1. Valve Plate
2. Retaining Ring
3. Spring Retainer
4. Spring
5. Spring Seat
6. Cylinder
7. Bolt
8. Slipper Guide Bearing
9. Spacer
10. Slipper Guide
11. Piston
12. Bolt
13. Bolt
14. Block
15. Spring
16. Servo Arm
17. Pin
18. Washer
19. Swash Plate Guide
20. Pin
21. Housing
22. Swash Plate
23. Bearing Assembly
24. Pin
25. Housing

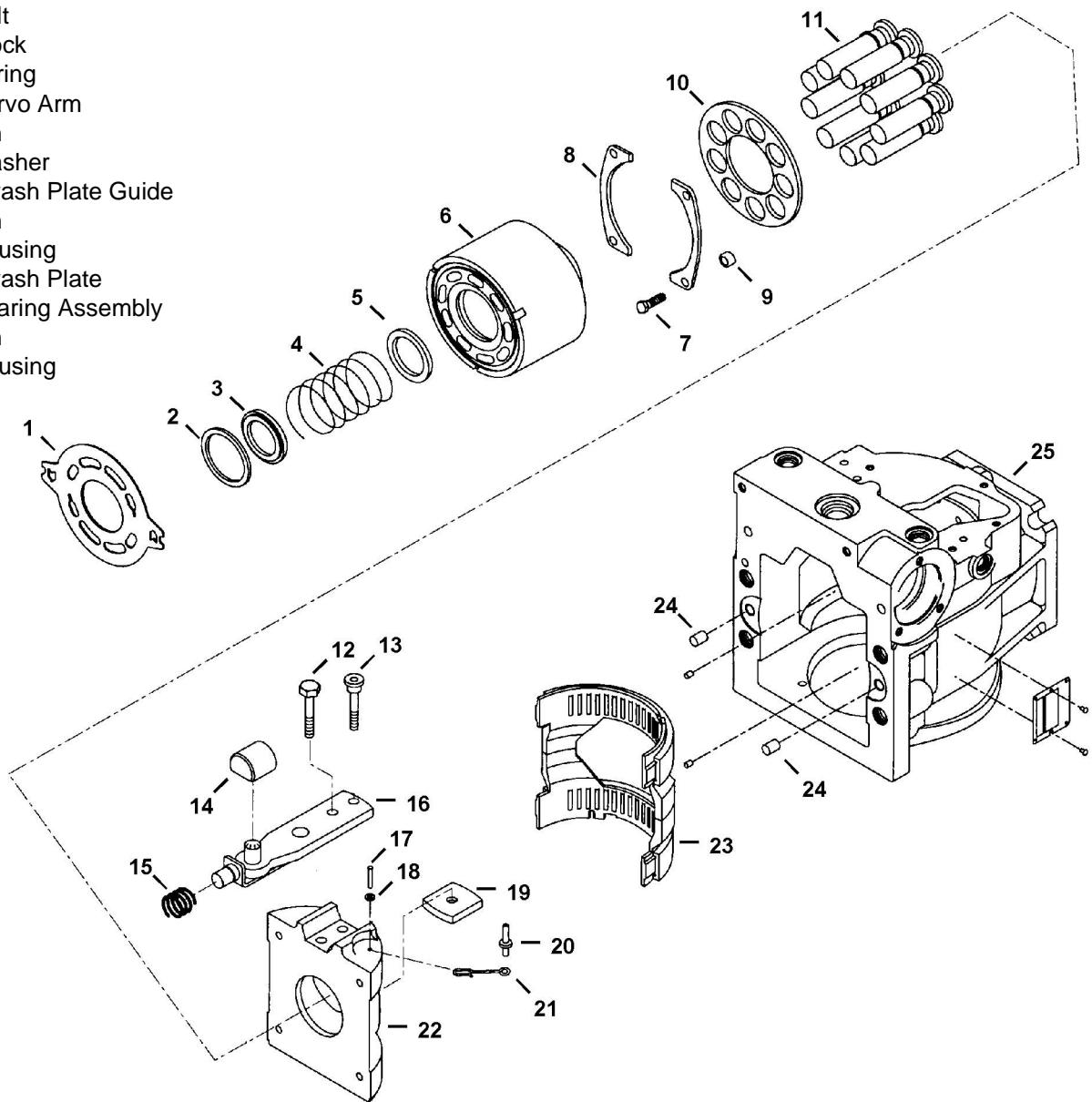

B-19856

HYDROSTATIC PUMP (CONT'D)

Disassembly (Cont'd)

Figure 30-40-43

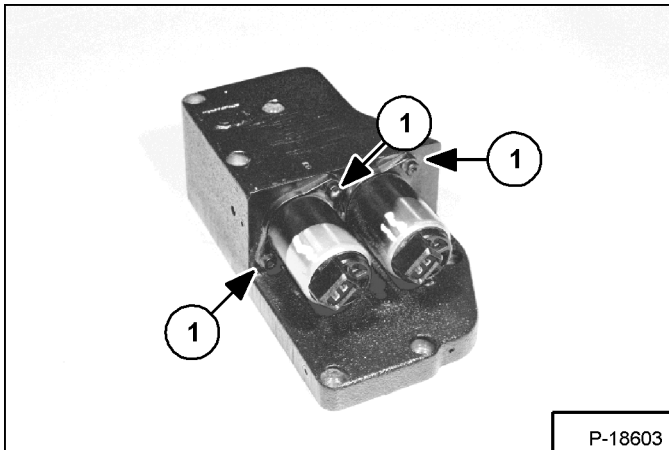

Remove the four solenoid mounting screws (Item 1) [Figure 30-40-43].

Figure 30-40-44

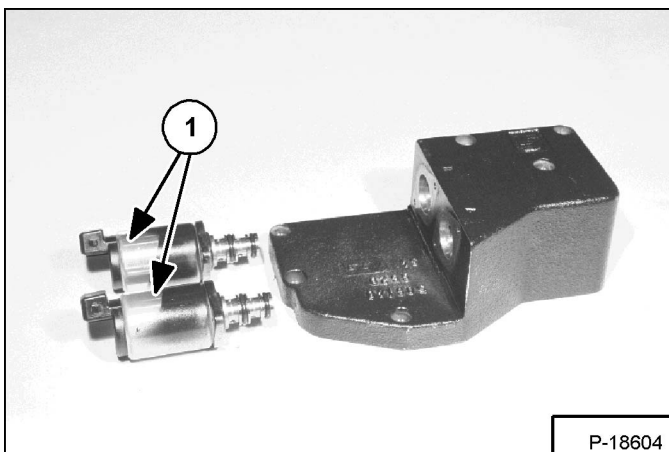

Remove the solenoids (Item 1) [Figure 30-40-44] from the manifold.

Figure 30-40-45

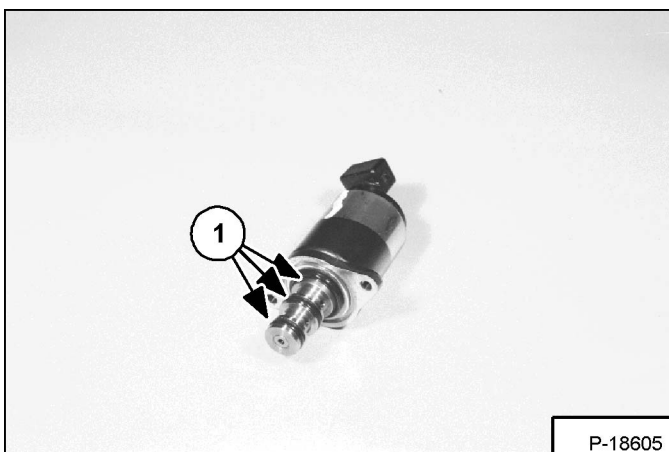

Remove and discard the three O-rings (Item 1) [Figure 30-40-45] from the solenoid.

Figure 30-40-46

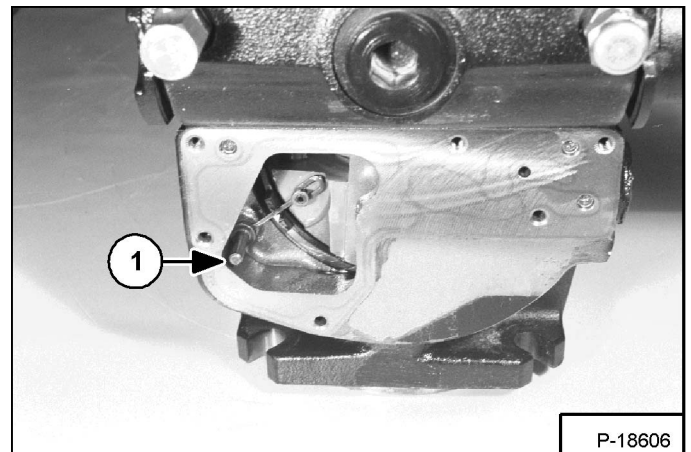

Remove the anchor pin (Item 1) [Figure 30-40-46].

HYDROSTATIC PUMP (CONT'D)

Assembly (Cont'd)

Figure 30-40-82

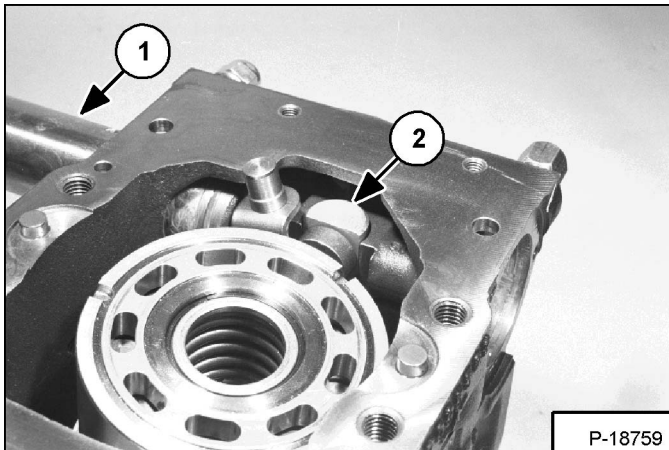

Holding the cylinder block and swash plate assembly approximately 1/2" (12 mm) above the bearings. Position the servo piston (Item 1) on the bronze slider block (Item 2) [Figure 30-40-82]. Take care not to wedge the block, the parts should slide freely.

Figure 30-40-83

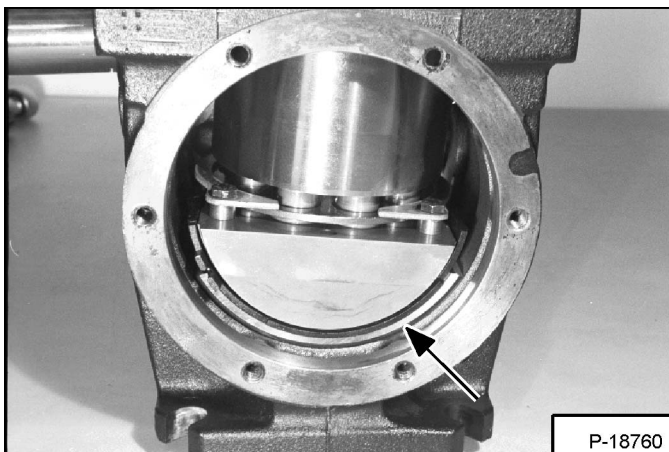

Lower the cylinder block and swash plate assembly until the swash plate is properly located on the bearings [Figure 30-40-83].

Figure 30-40-84

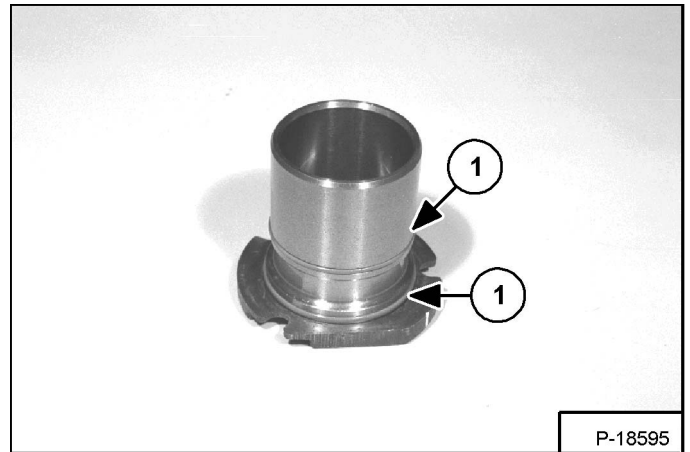

Install new O-rings (Item 1) [Figure 30-40-84] on the servo end cap.

Lightly lubricate the O-rings and the inner surface of the end cap.

Figure 30-40-85



Hold the servo piston in position and install the servo end cap [Figure 30-40-85].

HYDROSTATIC PUMP (CONT'D)

Assembly (Cont'd)

Figure 30-40-122

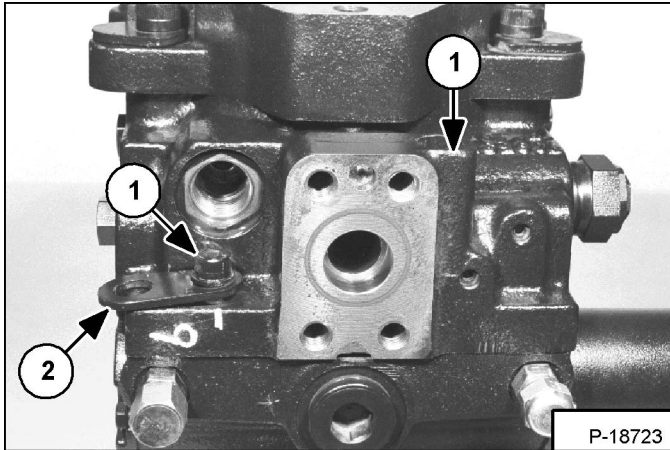

Install the two mounting bolts (Item 1) [Figure 30-40-122] and tighten to 28 ft.-lbs. (38 Nm) torque.

NOTE: Install the lifting bracket (Item 2) [Figure 30-40-122].

Figure 30-40-123

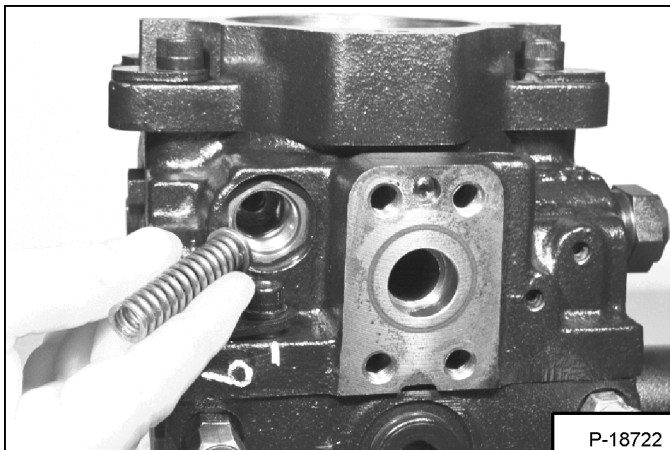

Install the spring and relief poppet into the charge pump [Figure 30-40-123].

Figure 30-40-124

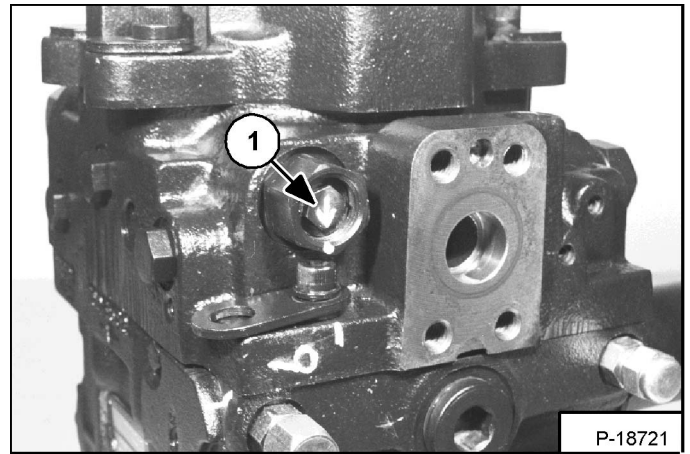

Install the plug with lock nut (Item 1) [Figure 30-40-124], align the marks made at disassembly. Tighten the lock nut to 38 ft.-lbs. (52 Nm) torque.

Figure 30-40-125

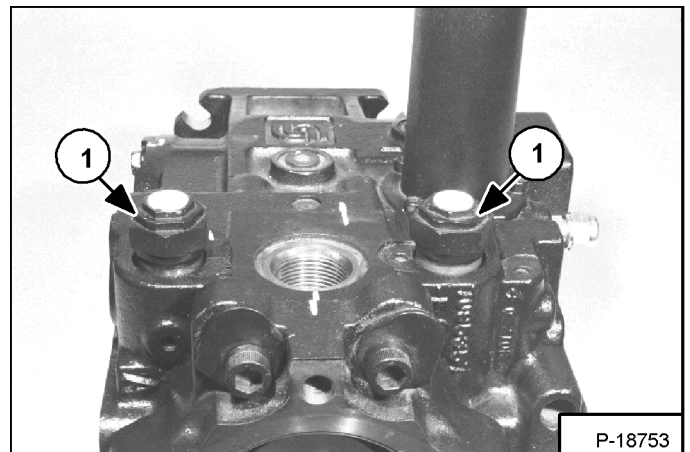

Lightly lubricate and install both multi-function valve assemblies (Item 1) [Figure 30-40-125] in the charge pump. Tighten to 66 ft.-lbs. (89 Nm) torque.

AXLE AND DIFFERENTIAL (FRONT) (For S/N 362811001 - 362812000, S/N 362911001 - 362912000)

General Information

For photo clarity, the following axle procedures are done with the complete axle assembly removed from the machine, although the planetary carrier, wheel hub, steering knuckle and drive axle procedures may be done with the axle assembly installed in the machine. For complete axle repair, the following must be done.

- Front Axle removal. (See "FRONT AXLE WITH FRAME LEVELING (For S/N 362911001 - 362912000)" on page 40-31-1.) or (See "FRONT AXLE WITHOUT FRAME LEVELING (For S/N

362811001 - 362812000)" on page 40-30-1)

- Drive motor removal. (See "Removal And Installation" on page 30-30-1)
- Drive box removal. (See "Disassembly" on page 20-70-2)
- Front steering cylinder removal. (See "Removal And Installation" on page 20-60-1.)
- Frame leveling cylinder removal (if equipped). (See "Removal And Installation (For S/N 362811001 - 362812000, S/N 362911001 - 362912000)" on page 20-100-1.)

Planetary Carrier Parts Identification

1. Plug
2. Bolt
3. Planetary Carrier
4. Thrust Pin
5. Shaft
6. Needle Bearings
7. Gear
8. Thrust Washer
9. Snap Ring

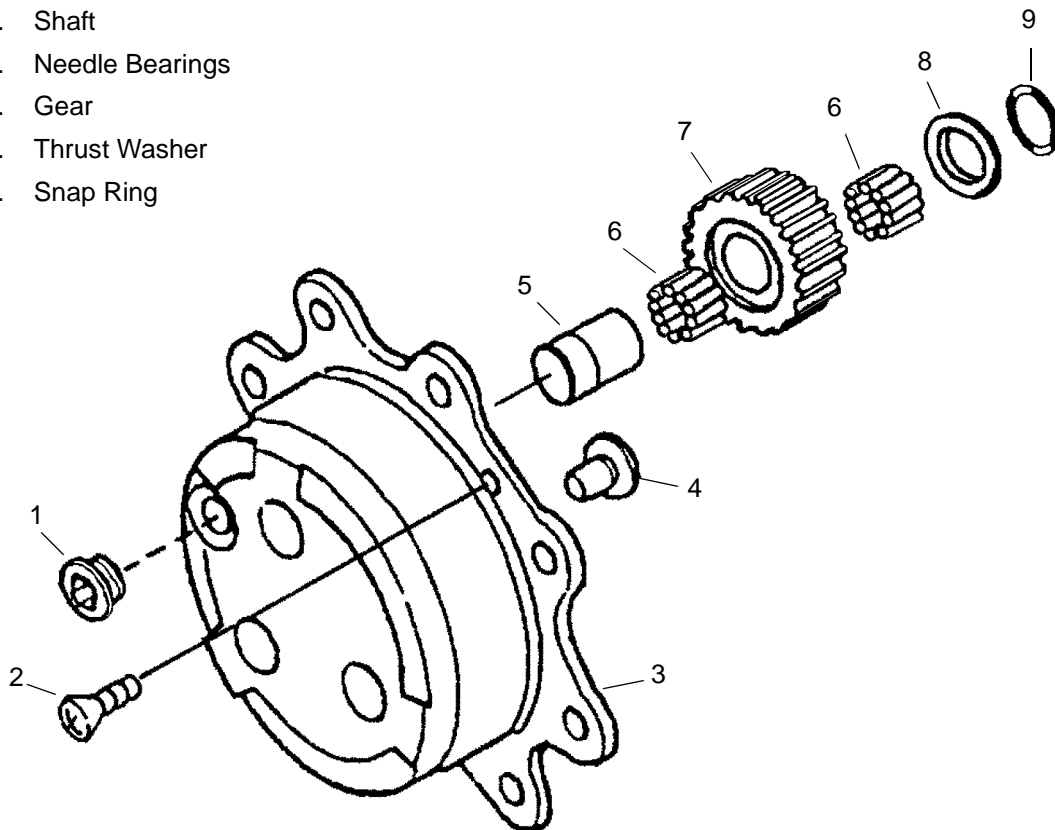

b-19863

AXLE AND DIFFERENTIAL (FRONT) (For S/N 362811001 - 362812000, S/N 362911001 - 362912000) (CONT'D)

Steering Knuckle Disassembly (Cont'd)

Figure 40-20-28

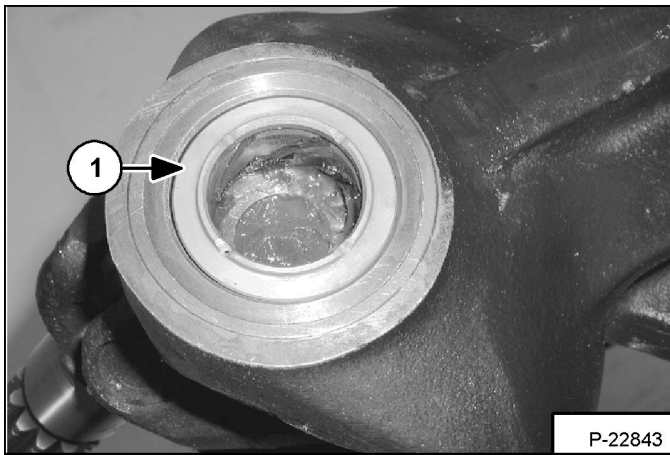

Remove the spacer washer (Item 1) [Figure 40-20-28] from the top of the axle.

Figure 40-20-29

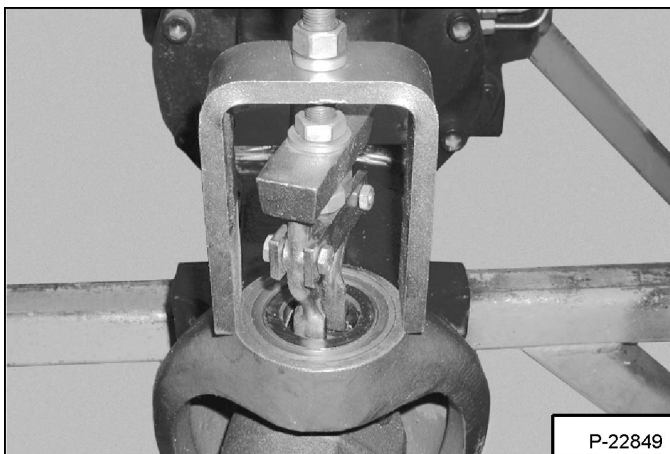
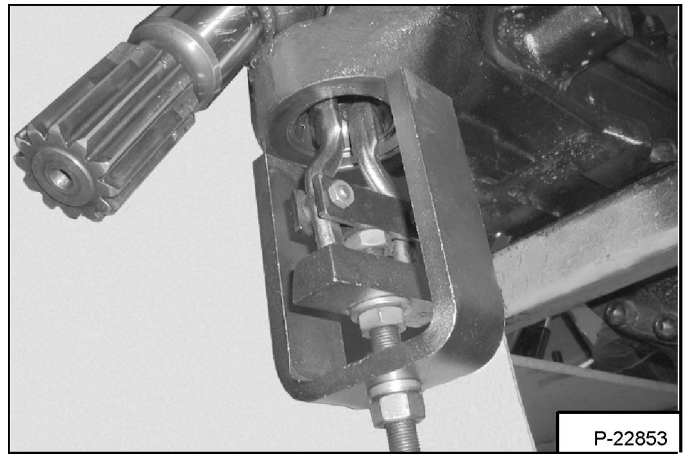
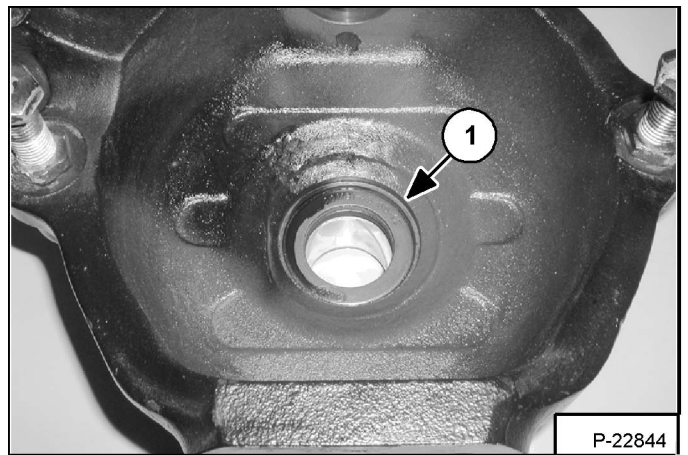

Figure 40-20-30



Using a puller, remove the top and bottom bushings from the axle [Figure 40-20-29] & [Figure 40-20-30].

Figure 40-20-31



Remove the seal (Item 1) [Figure 40-20-31] from the knuckle assembly.

AXLE AND DIFFERENTIAL (FRONT) (For S/N 362811001 - 362812000, S/N 362911001 - 362912000) (CONT'D)

Brake Group Disassembly (Cont'd)

Figure 40-20-62

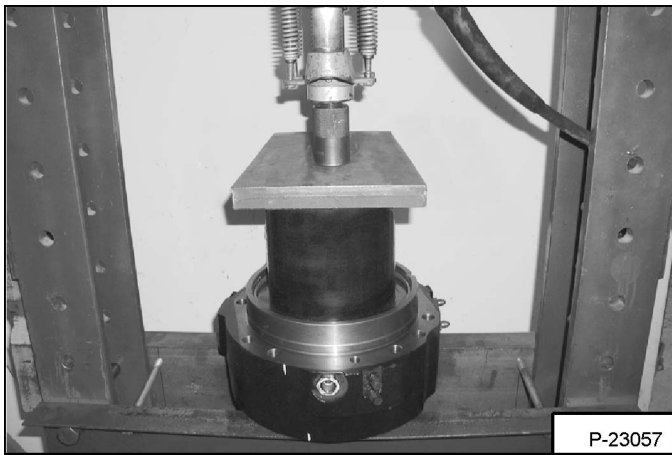

Using a 6-1/2 inch O.D. tube and suitable press, apply enough downward pressure on the Belleville springs allowing the split ring retainer ring to drop down [Figure 40-20-62].

Figure 40-20-63

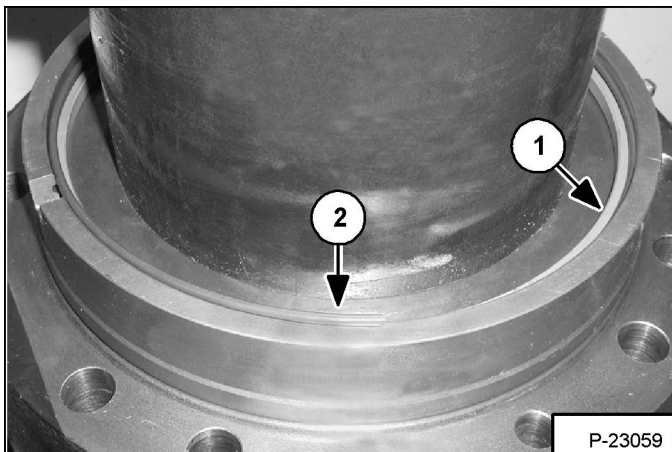

With the split ring retainer ring (Item 1) in the down position, remove the split ring (Item 2) [Figure 40-20-63].

Carefully release the pressure and remove the brake housing from the press.

Figure 40-20-64

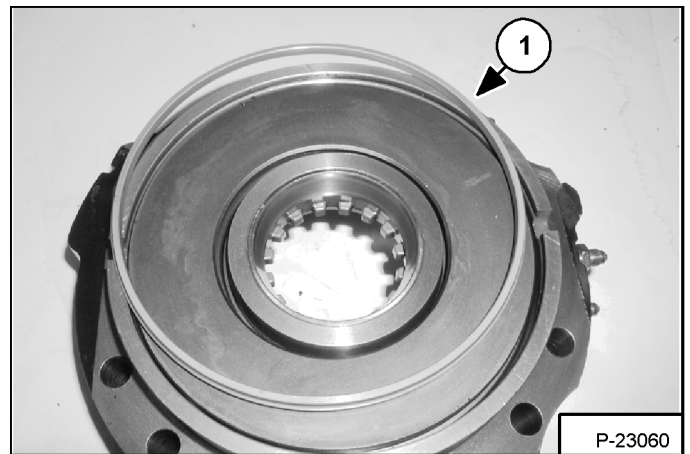

Remove the split ring retainer (Item 1) [Figure 40-20-64].

Figure 40-20-65

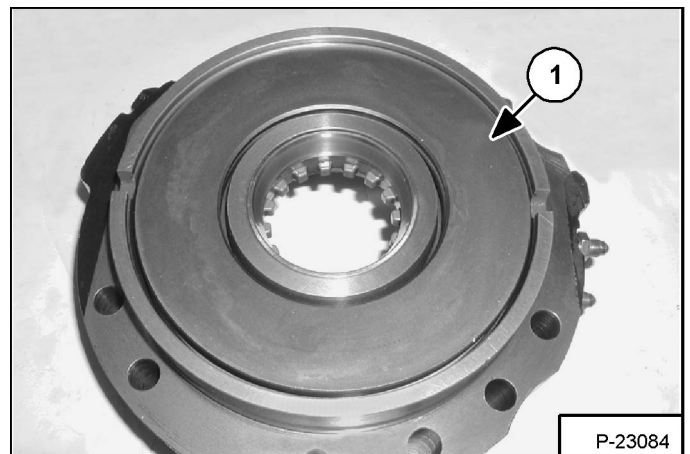

Remove the two Belleville springs (Item 1) [Figure 40-20-65].

AXLE AND DIFFERENTIAL (FRONT) (For S/N 362811001 - 362812000, S/N 362911001 - 362912000) (CONT'D)

Pinion Group Disassembly (Cont'd)

Figure 40-20-94

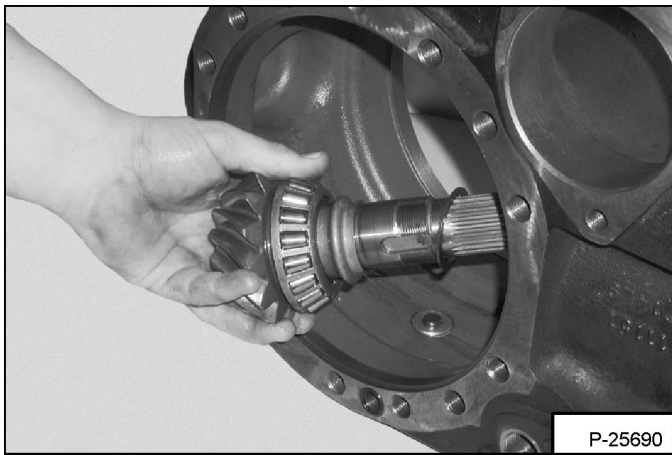

Remove the pinion shaft from the housing [Figure 40-20-94].

Figure 40-20-95

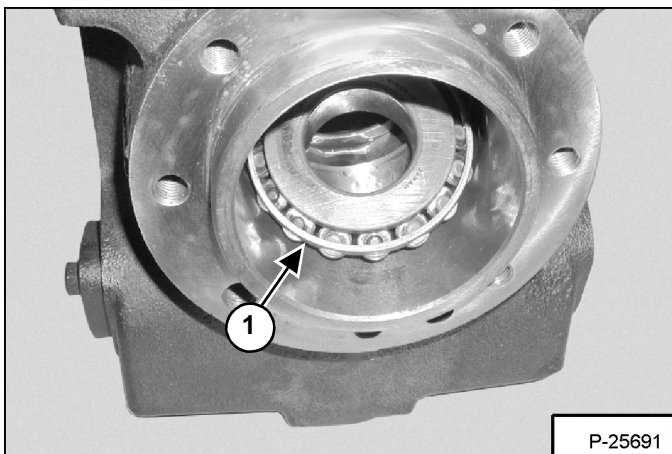

Remove the outer bearing (Item 1) [Figure 40-20-95].

Figure 40-20-96

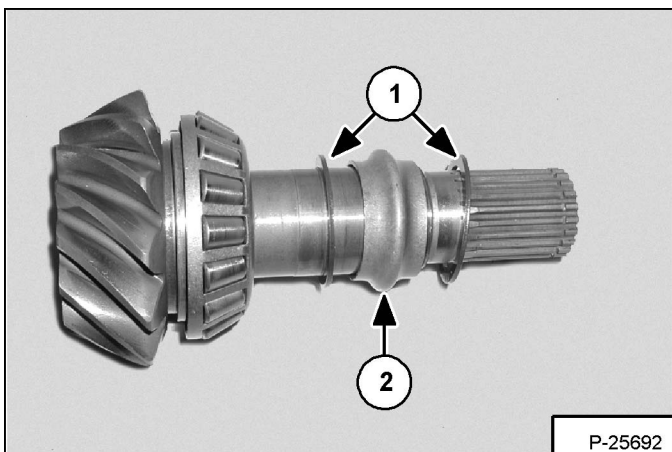

Remove the two washers (Item 1) and spacer (Item 2) [Figure 40-20-96] from the pinion shaft.

Figure 40-20-97

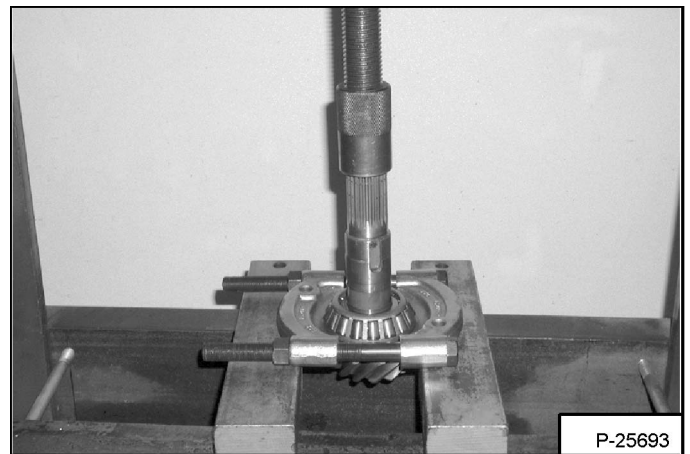

Remove the bearing from the pinion shaft [Figure 40-20-97].

AXLE AND DIFFERENTIAL (FRONT) (For S/N
362811001 - 362812000, S/N 362911001 - 362912000)
(CONT'D)

Differential Assembly (Cont'd)

Figure 40-20-132

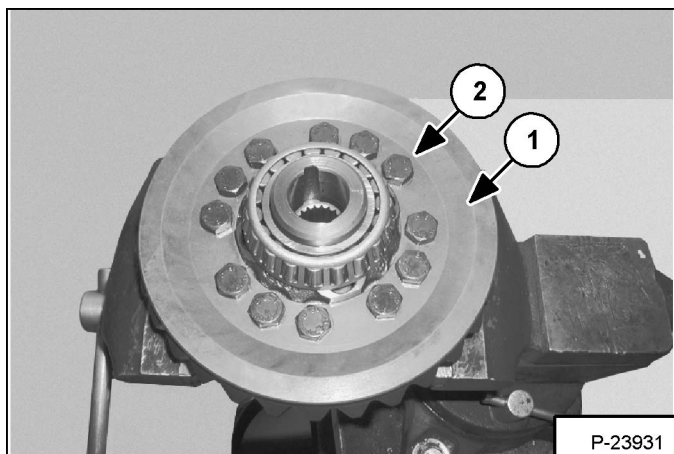

Install the ring gear (Item 1) and twelve bolts (Item 2) [Figure 40-20-132]. Tighten the bolts to 58 ft.-lbs. (78 Nm) torque.

Figure 40-20-133

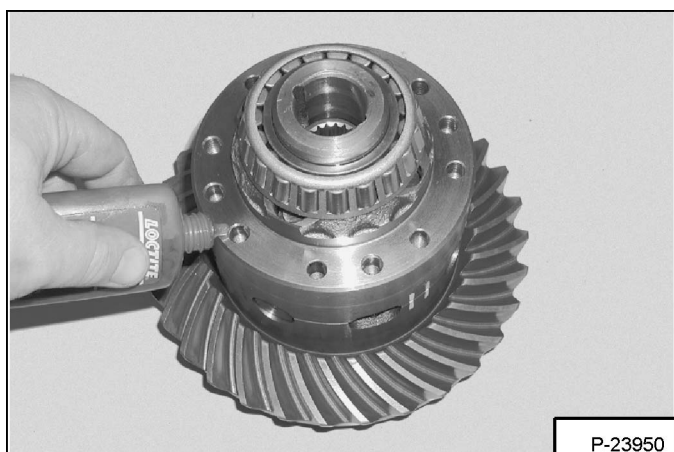

Apply LOCTITE #270 to the end of the mounting bolts [Figure 40-20-133].

CLICK HERE TO **DOWNLOAD** THE COMPLETE MANUAL

- Thank you very much for reading the preview of the manual.
- You can download the complete manual from: www.heydownloads.com by clicking the link below



- Please note: If there is no response to CLICKING the link, please download this PDF first and then click on it.

CLICK HERE TO **DOWNLOAD** THE COMPLETE MANUAL

AXLE AND DIFFERENTIAL (FRONT) (For S/N 362811001 - 362812000, S/N 362911001 - 362912000) (CONT'D)

Brake Group Assembly (Cont'd)

Figure 40-20-170

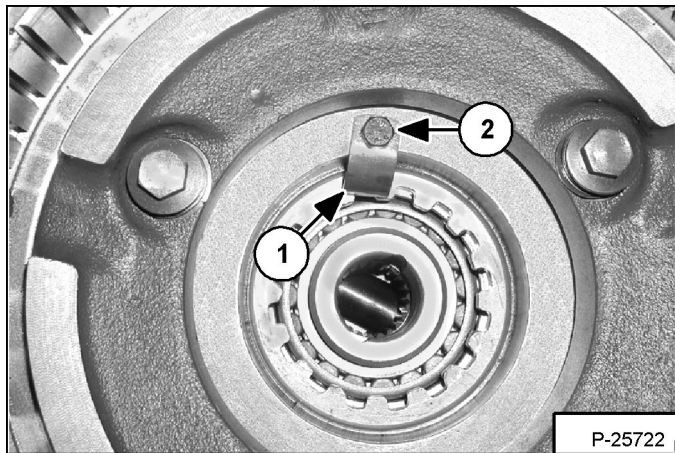

Install the lock nut retainer (Item 1) and bolt (Item 2) [Figure 40-20-170] tighten the bolt to 10 ft.-lbs. (13 Nm) torque.

Figure 40-20-171

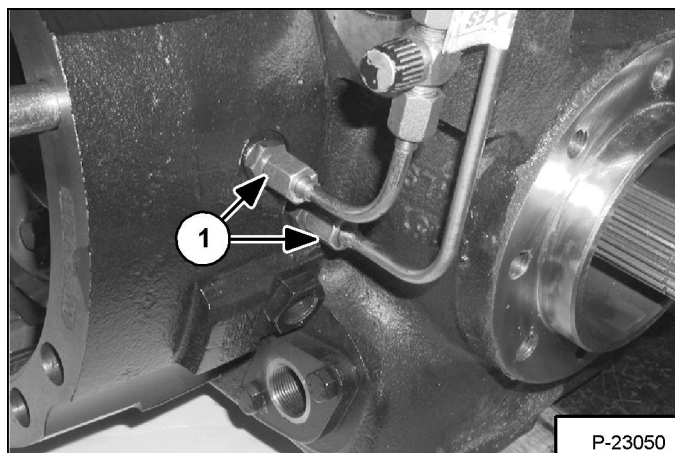

Install the two tubelines (Item 1) [Figure 40-20-171].

Figure 40-20-172

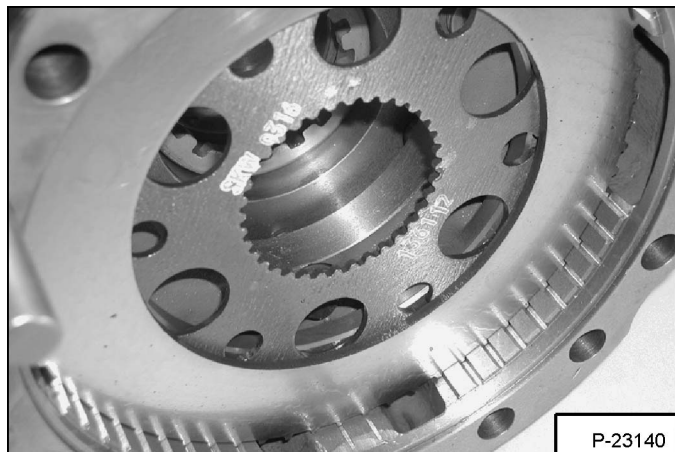

Install the thick spacer plate into the grooves in the brake housing followed by a friction plate and a thin spacer plate [Figure 40-20-172].

Figure 40-20-173

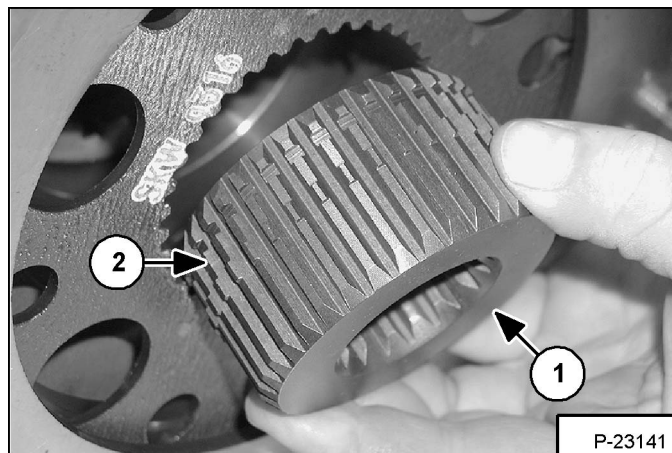

Install the coupler (Item 1) [Figure 40-20-173] in the friction plate.

Note the position of the groove (Item 2) [Figure 40-20-173] in the coupler.

AXLE AND DIFFERENTIAL (FRONT) (For S/N 362811001 - 362812000, S/N 362911001 - 362912000) (CONT'D)

Wheel Hub Assembly (Cont'd)

Figure 40-20-207

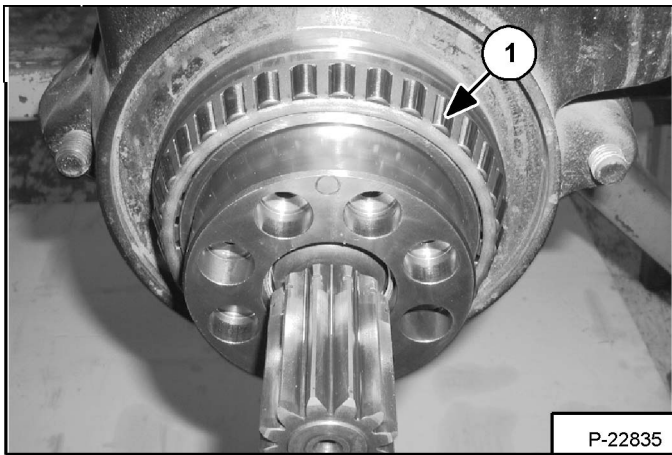

Install the inner bearing (Item 1) [Figure 40-20-207] onto the steering knuckle.

Figure 40-20-208

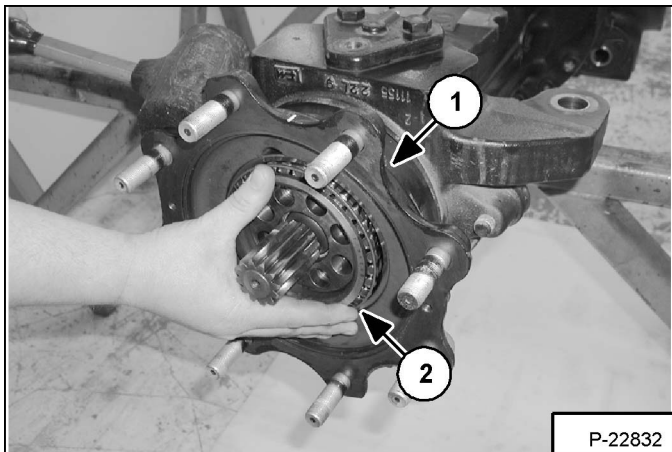

Install the hub assembly (Item 1) and outer bearing (Item 2) [Figure 40-20-208] onto the steering knuckle.

Figure 40-20-209

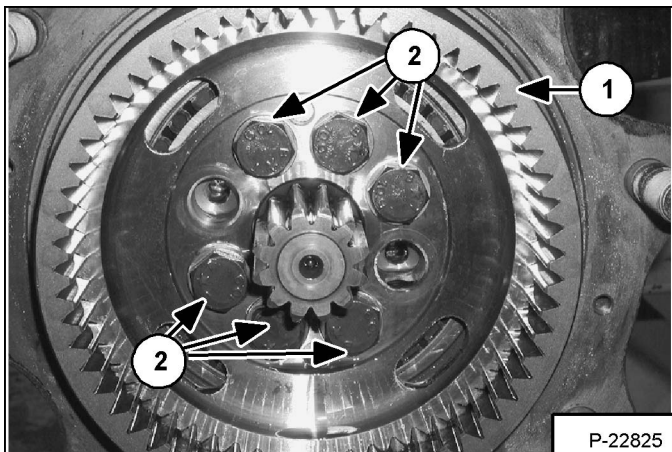

Install the ring gear assembly (Item 1) onto the steering knuckle. Install the six mounting bolts (Item 2) [Figure 40-20-209] and tighten to 88 ft.-lbs. (120 Nm) torque.

Figure 40-20-210

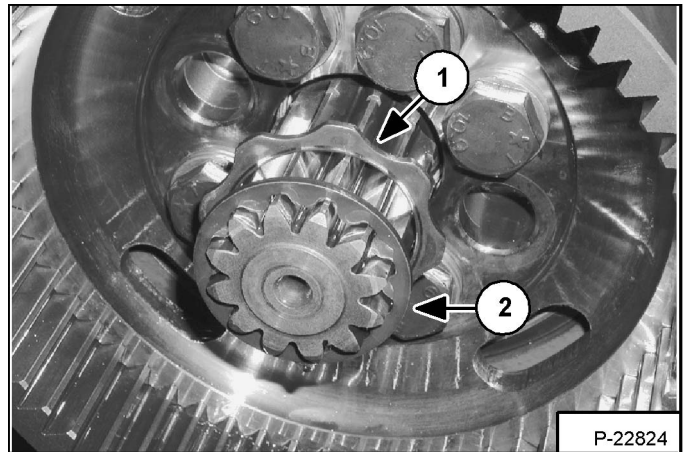

Install the spacer (Item 1) and thrust washer (Item 2) [Figure 40-20-210] on the axle shaft.

AXLE AND DIFFERENTIAL (REAR) (For S/N 362811001 - 362812000, S/N 362911001 - 362912000) (CONT'D)

Wheel Hub Disassembly (Cont'd)

Figure 40-21-14

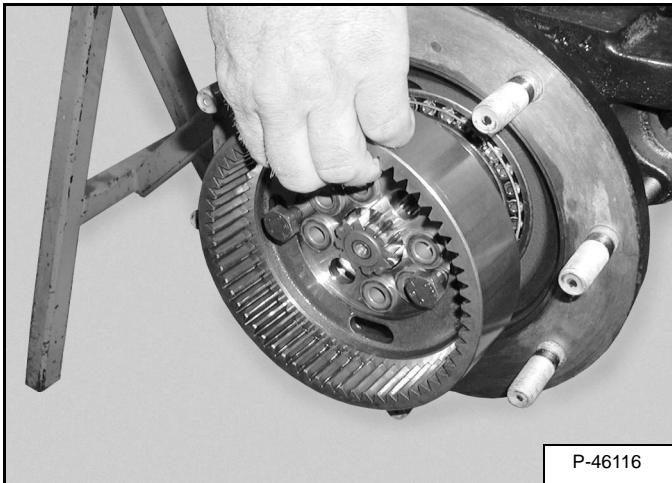

Remove the ring gear assembly [Figure 40-21-14]. (Both sides)

Figure 40-21-15

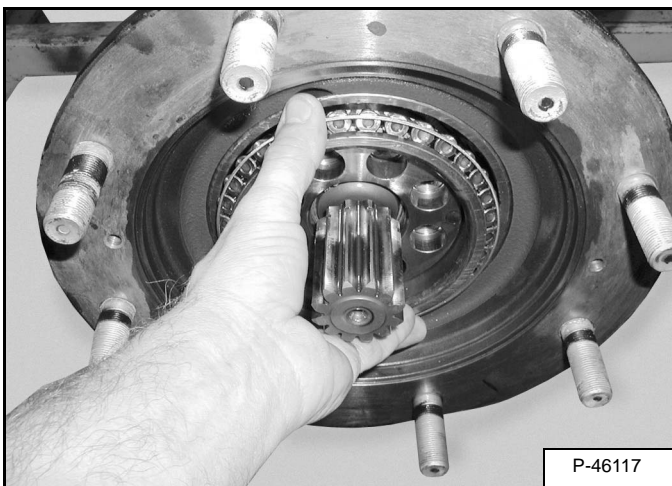

Remove the outer bearing and hub assembly from the axle [Figure 40-21-15]. (Both sides)

NOTE: Use care while removing, as assembly may remove easy.

Figure 40-21-16

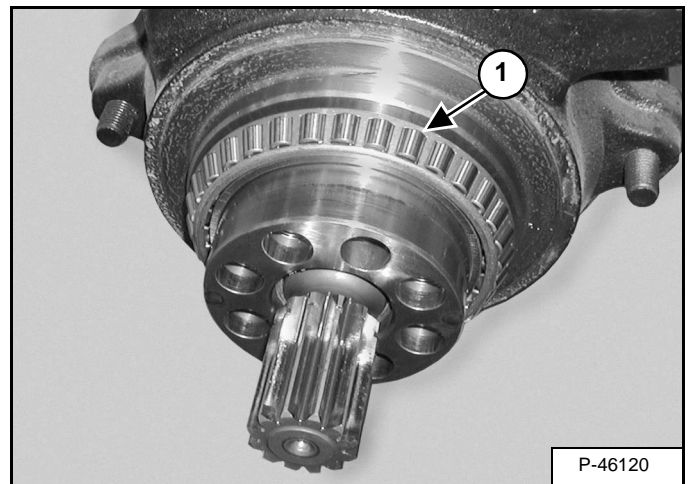

Remove the inner bearing (Item 1) [Figure 40-21-16] from the swivel housing. (Both sides)

Figure 40-21-17



Remove the retainer ring (Item 1) [Figure 40-21-17] from the ring gear assembly.

AXLE AND DIFFERENTIAL (REAR) (For S/N 362811001 - 362812000, S/N 362911001 - 362912000) (CONT'D)

Differential Disassembly (Cont'd)

Figure 40-21-48

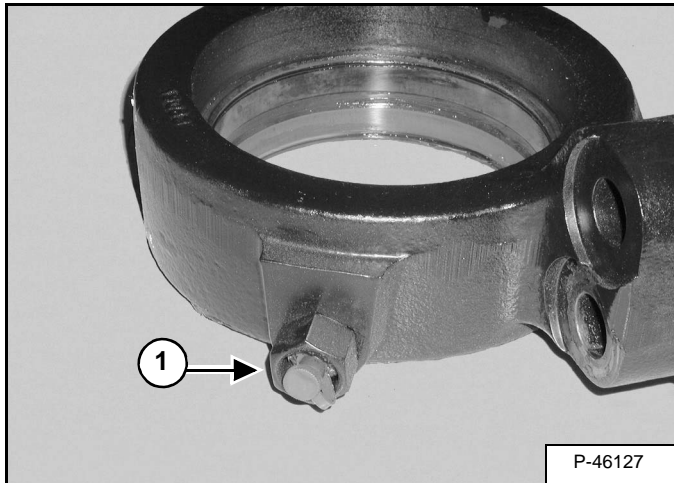

Loosen the retainer (Item 1) [Figure 40-21-48] on the front mount bracket.

Figure 40-21-49

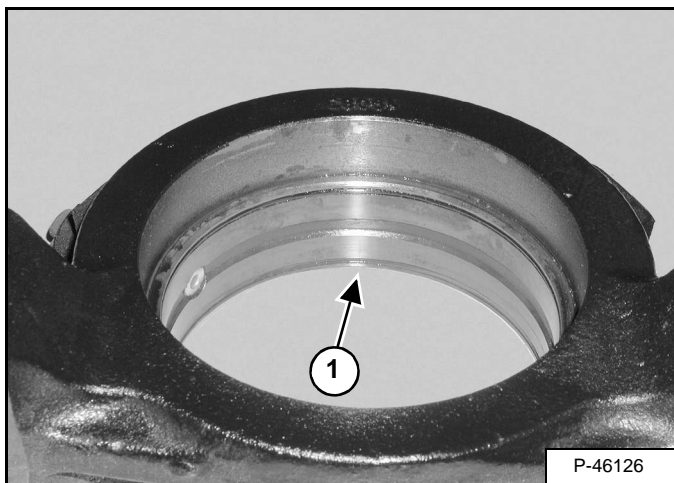

Remove the bushing (Item 1) [Figure 40-21-49] from the front mount bracket.

Figure 40-21-50

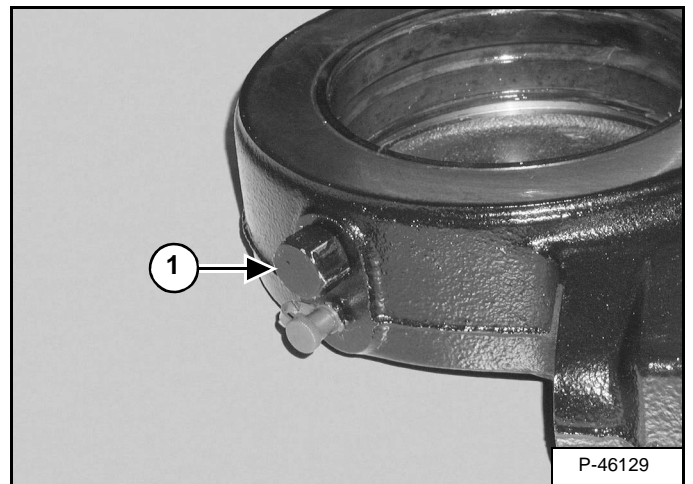

Loosen the retainer (Item 1) [Figure 40-21-50] on the rear mount bracket.

Figure 40-21-51

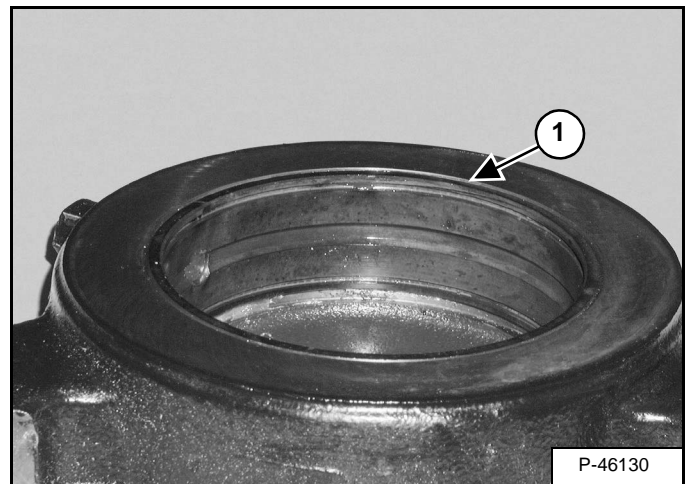

Remove the bushing (Item 1) [Figure 40-21-51] from the rear mount bracket.

AXLE AND DIFFERENTIAL (REAR) (For S/N 362811001 - 362812000, S/N 362911001 - 362912000) (CONT'D)

Pinion Group Disassembly (Cont'd)

Figure 40-21-80

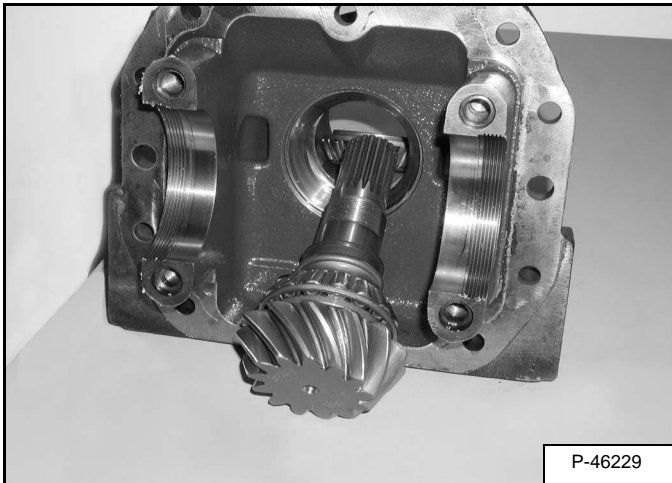

Remove the pinion shaft from the housing [Figure 40-21-80].

Figure 40-21-81

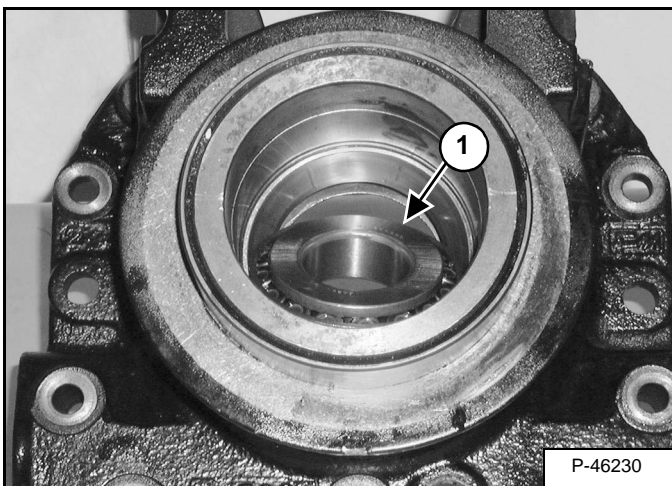

Remove the outer bearing (Item 1) [Figure 40-21-81].

Figure 40-21-82

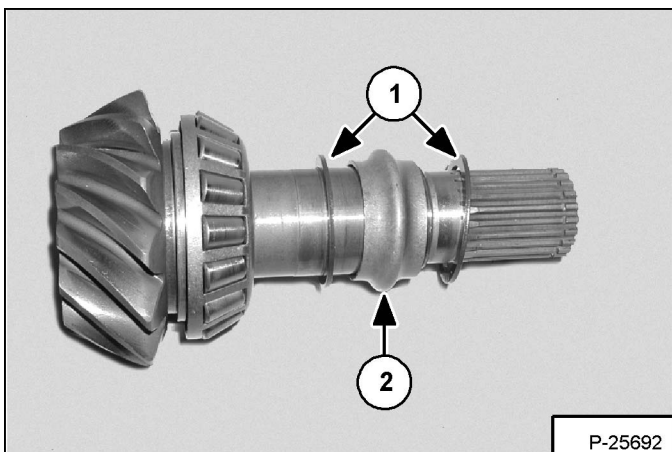

Remove the two washers (Item 1) and spacer (Item 2) [Figure 40-21-82] from the pinion shaft.

Figure 40-21-83

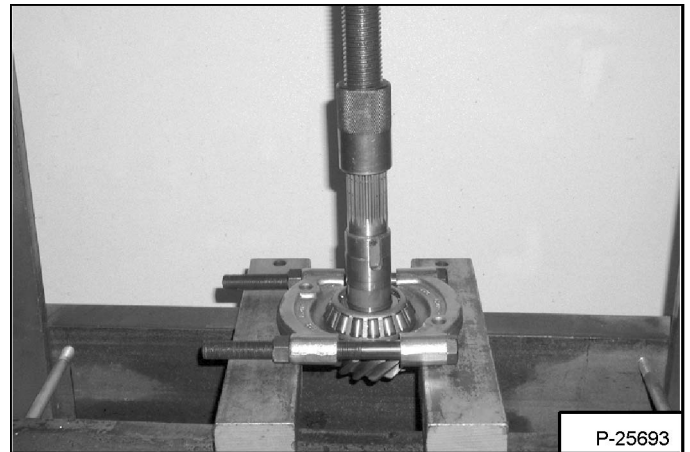

Remove the bearing from the pinion shaft [Figure 40-21-83].

AXLE AND DIFFERENTIAL (REAR) (For S/N 362811001 - 362812000, S/N 362911001 - 362912000) (CONT'D)

Differential Assembly (Cont'd)

Figure 40-21-118

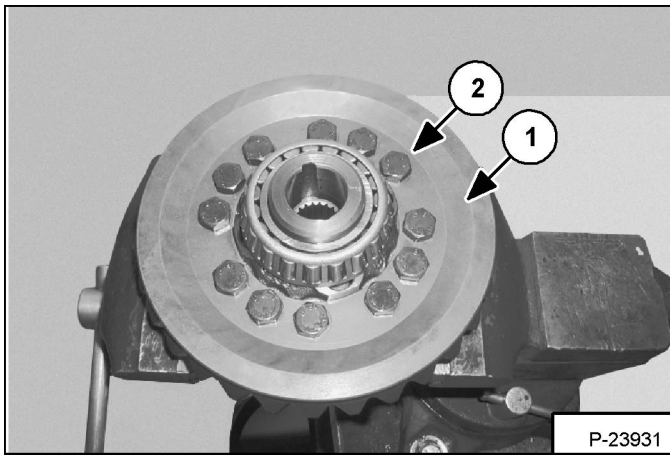

Install the ring gear (Item 1) and twelve bolts (Item 2) [Figure 40-21-118]. Tighten the bolts to 58 ft.-lbs. (78 Nm) torque.

Figure 40-21-119

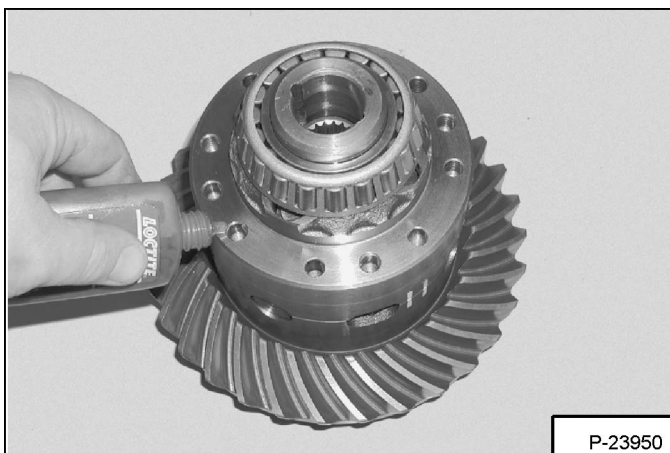

Apply LOCTITE #270 to the end of the mounting bolts [Figure 40-21-119].

Figure 40-21-120

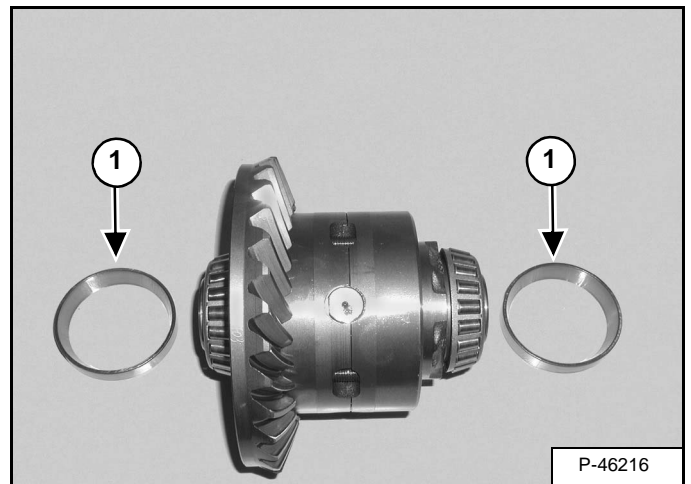

Install the bearing races (Item 1) [Figure 40-21-120] on the bearings.

Figure 40-21-121

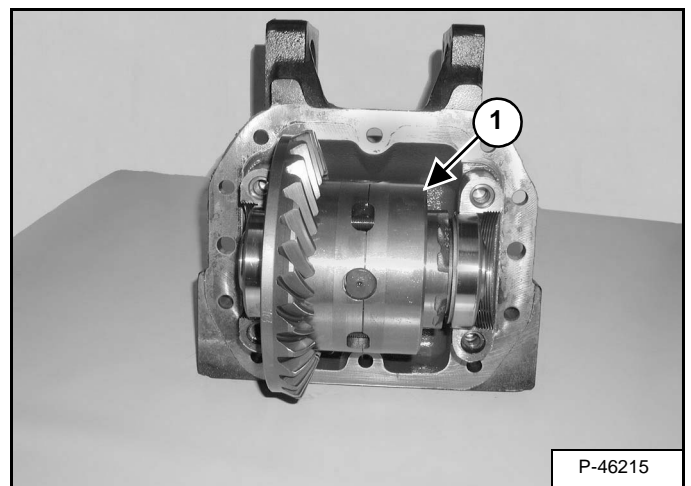

Install the differential assembly (Item 1) [Figure 40-21-121] in the housing.

AXLE AND DIFFERENTIAL (REAR) (For S/N 362811001 - 362812000, S/N 362911001 - 362912000) (CONT'D)

Axle Housing/Drive Axle Assembly (Cont'd)

Figure 40-21-156



Fully press the two bearing cups into the drive shaft yoke [Figure 40-21-156].

Figure 40-21-157

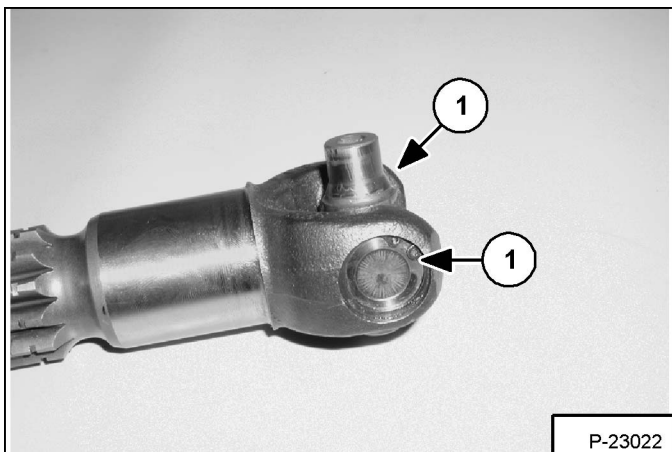

Install the two snap rings (Item 1) [Figure 40-21-157].

Figure 40-21-158

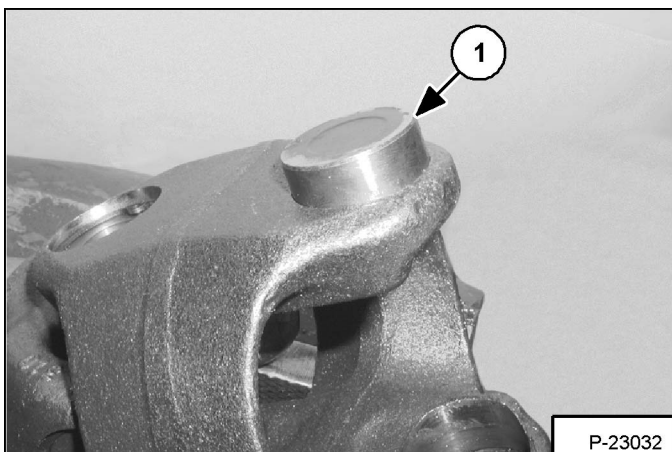

Partially install a new bearing cup (Item 1) [Figure 40-21-158] into the yoke.

Figure 40-21-159

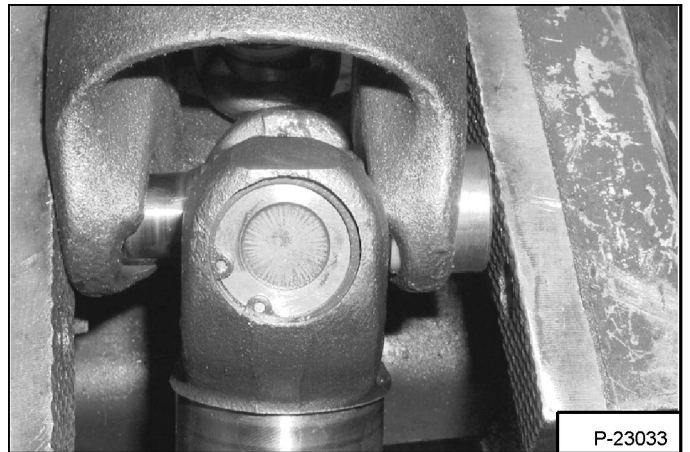

Install the cross/shaft assembly into the bearing cup [Figure 40-21-159].

AXLE AND DIFFERENTIAL (FRONT) (For S/N 362812001 and Above, S/N 362912001 and Above)

General Information

For photo clarity, the following axle procedures are done with the complete axle assembly removed from the machine, although the planetary carrier, wheel hub, steering knuckle and drive axle procedures may be done with the axle assembly installed in the machine. For complete axle repair, the following must be done.

- Rear Axle removal. (See "Removal" on page 40-91-1.)
- Rear steering cylinder removal. (See "Removal And Installation" on page 20-62-1.)

Planetary Carrier Parts Identification

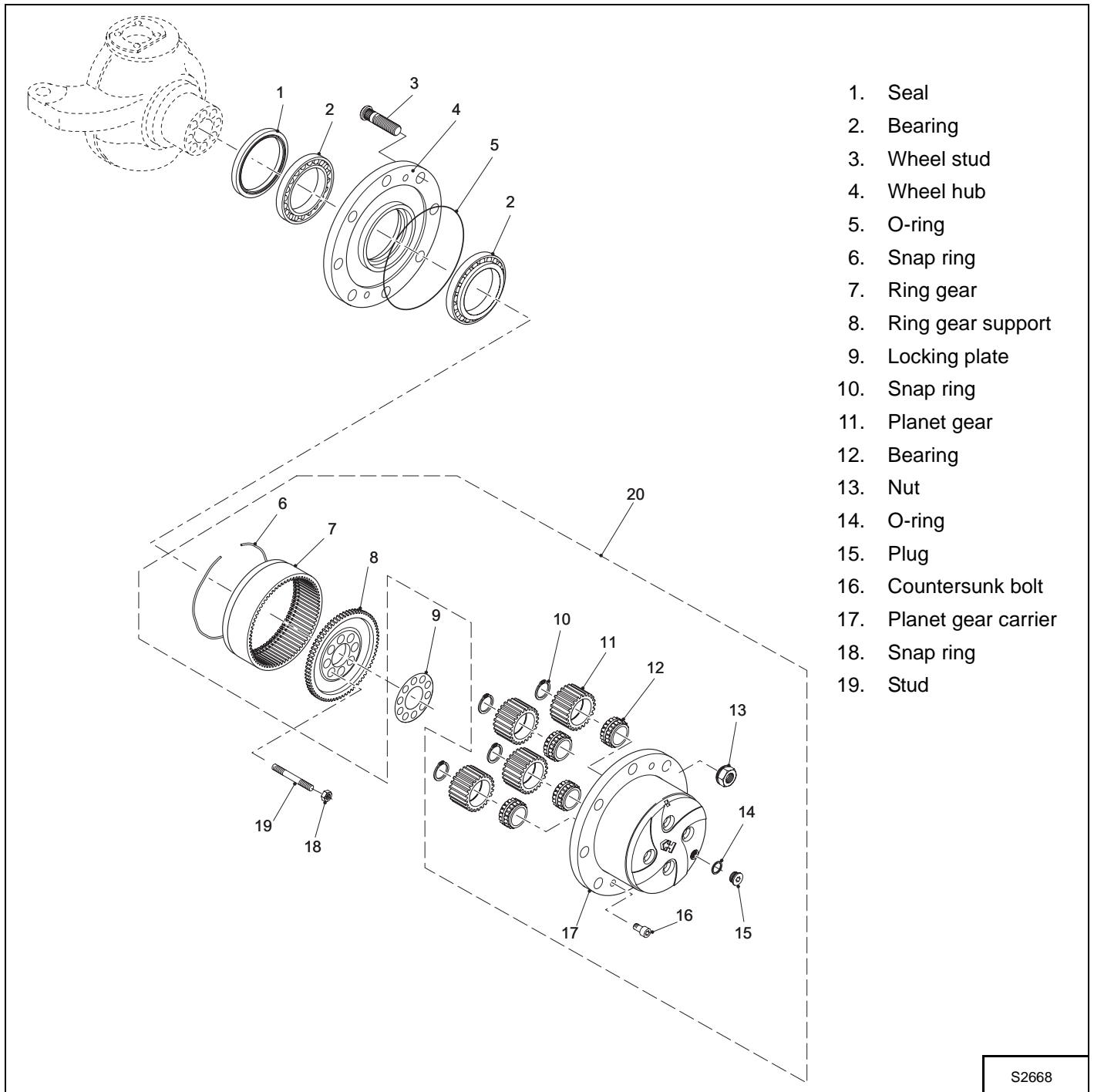

S2668

AXLE AND DIFFERENTIAL (FRONT) (For S/N 362812001 and Above, S/N 362912001 and Above) (CONT'D)

Drive Axle Disassembly (Cont'd)

Figure 40-22-28

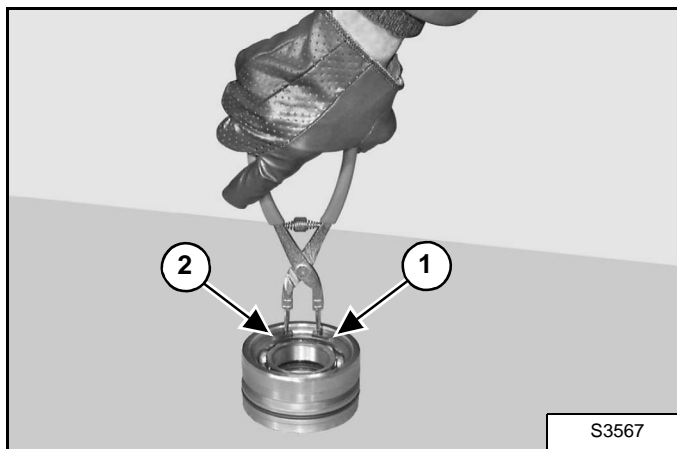

Remove the snap ring (Item 1) from the bearing (Item 2) [Figure 40-22-28].

Figure 40-22-29

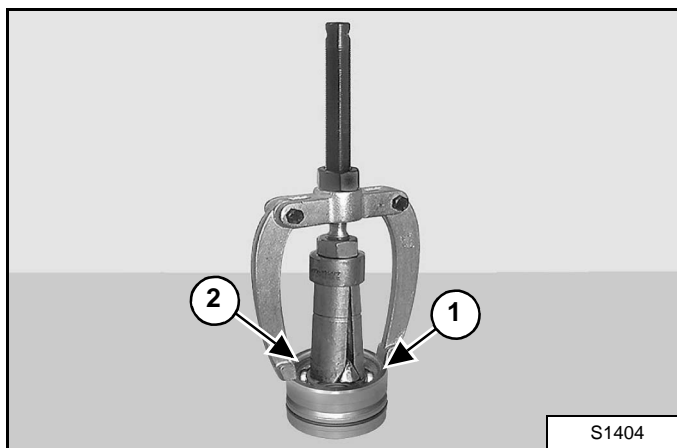

Use a puller to remove the bearing (Item 1), the sealing ring (Item 2) [Figure 40-22-29] and the O-ring.

AXLE AND DIFFERENTIAL (FRONT) (For S/N 362812001 and Above, S/N 362912001 and Above) (CONT'D)

Differential Disassembly (Cont'd)

Figure 40-22-56

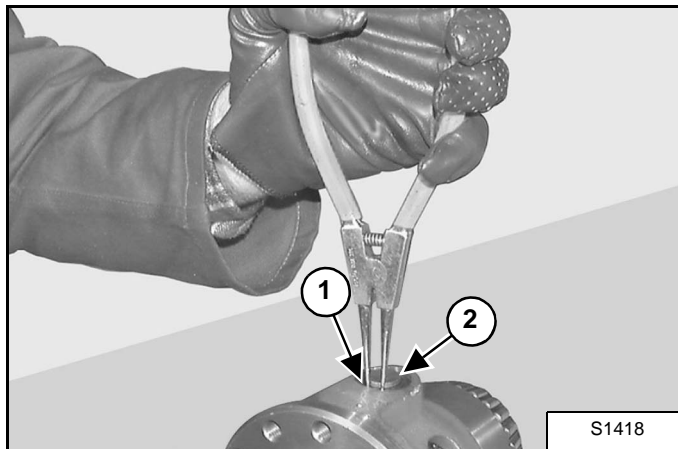

Remove the snap rings (Item 1) from the four pins (Item 2) [Figure 40-22-56] of the planet wheel gears.

Figure 40-22-57

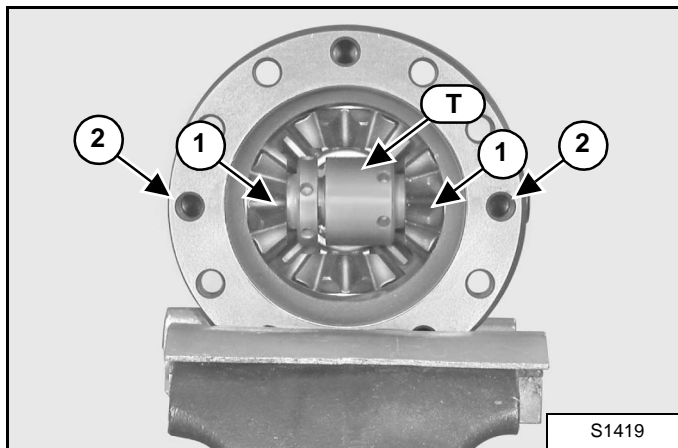

Insert a tool T between two planet wheel gears (Item 1) [Figure 40-22-57].

NOTE: Make sure that the tool is perfectly lined up with the pins (Item 2) [Figure 40-22-57] when locked.

Figure 40-22-58

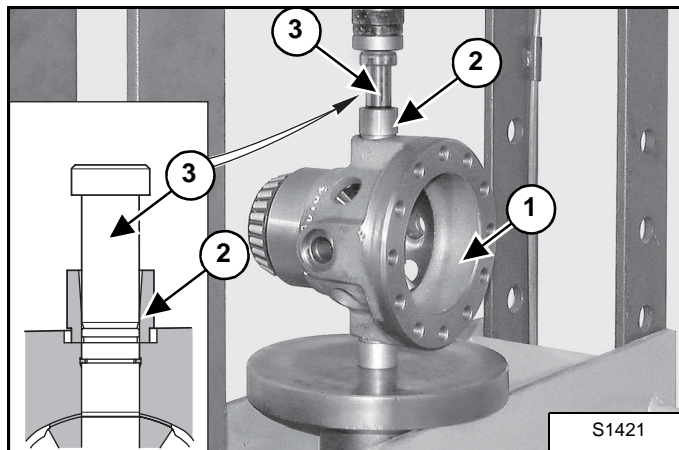

Place the differential carrier (Item 1) under a press, position a bushing (Item 2) and insert a pin (Item 3) [Figure 40-22-58]. Press the pin of the upper planet wheel gear into the tool T [Figure 40-22-57].

Figure 40-22-59

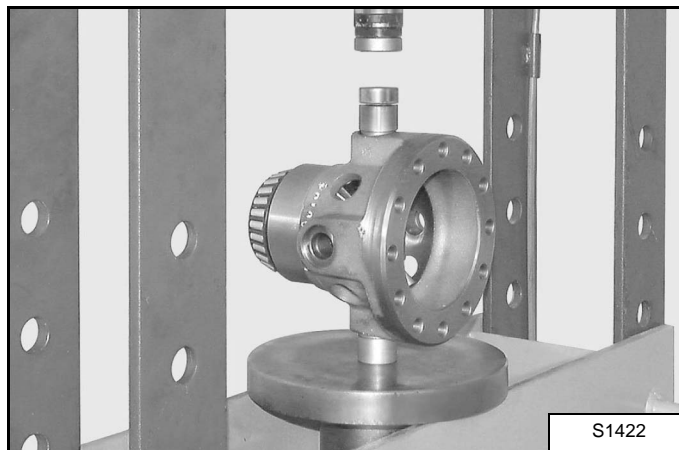

Remove pinion and bush.

NOTE: In this condition the tool contains the pin.

AXLE AND DIFFERENTIAL (FRONT) (For S/N 362812001 and Above, S/N 362912001 and Above) (CONT'D)

Pinion Group Assembly (Cont'd)

Figure 40-22-90

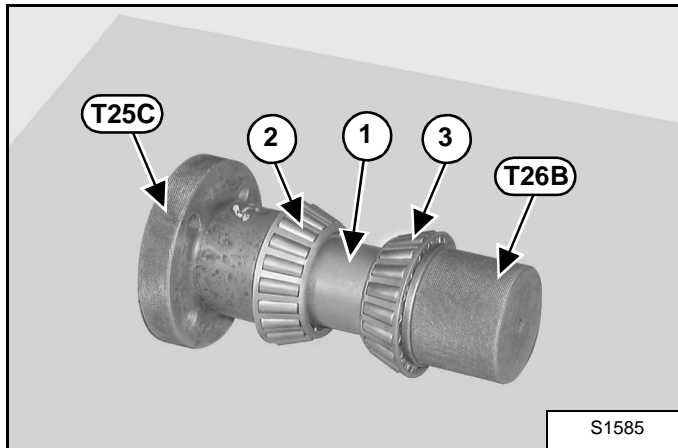

Remove the indicator and release tools and bearings from the central body.
 Re-install all and insert the distance piece (Item 1) between both bearings (Item 2 & 3) [Figure 40-22-90]; manually tighten the whole pack.

Figure 40-22-91

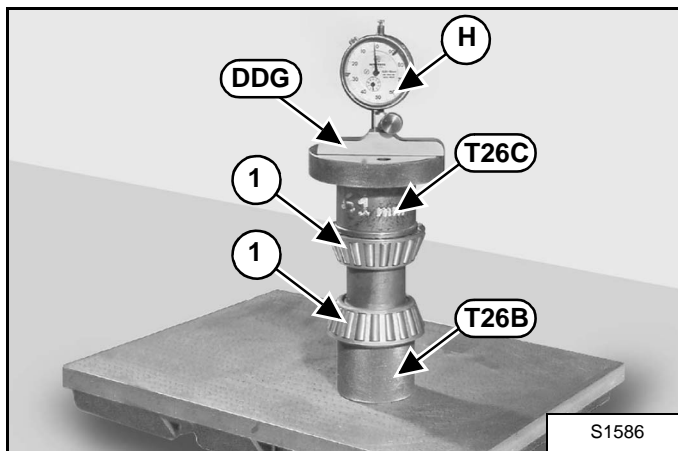

Insert depth gauge into tool **T26B-T26C** and measure variation "H" in relation to the zero setting performed in [Figure 40-22-89].

Figure 40-22-92

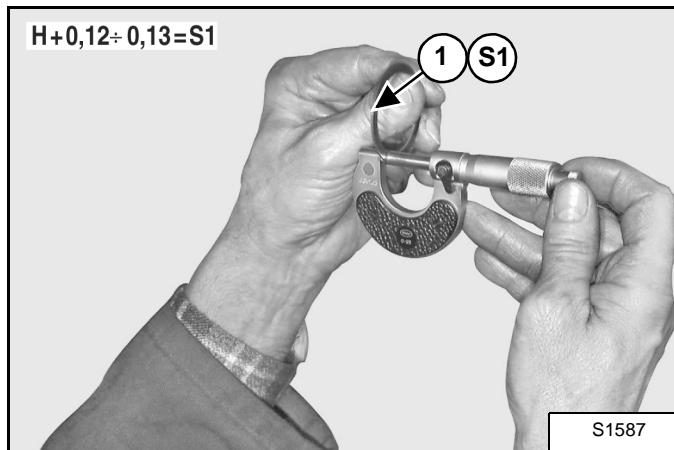

The variation is to be added to a set value of 0.12-0.13 mm, so as to obtain the size of shim "S1" (Item 1) [Figure 40-22-92] which will be inserted between the external bearing (Item 1) [Figure 40-22-91] and the distance piece (Item 1) [Figure 40-22-90] and subsequently, to determine the preload for the bearings.

Figure 40-22-93

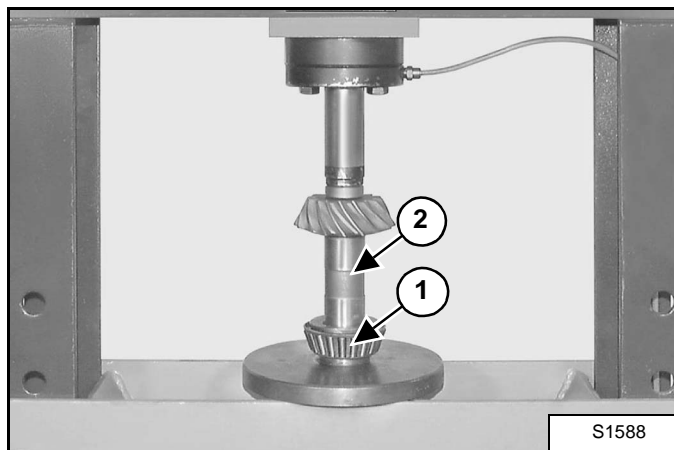

Position the internal bearing (Item 1) and the pinion (Item 2) [Figure 40-22-93] under a press. Force the bearing onto the pinion.

Brake System Assembly

Figure 40-22-126

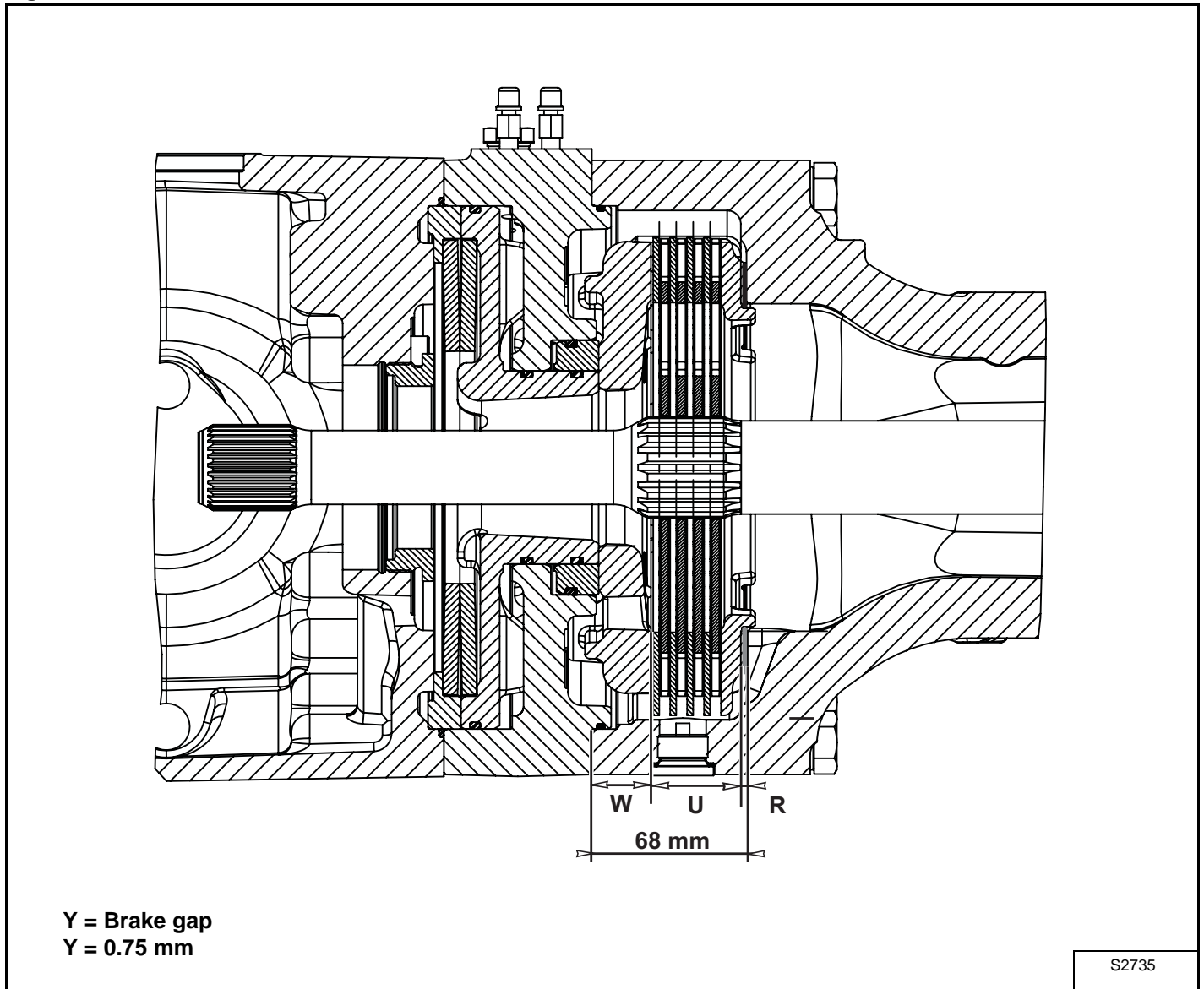

AXLE AND DIFFERENTIAL (FRONT) (For S/N 362812001 and Above, S/N 362912001 and Above) (CONT'D)

Steering Knuckle Assembly (Cont'd)

Figure 40-22-157

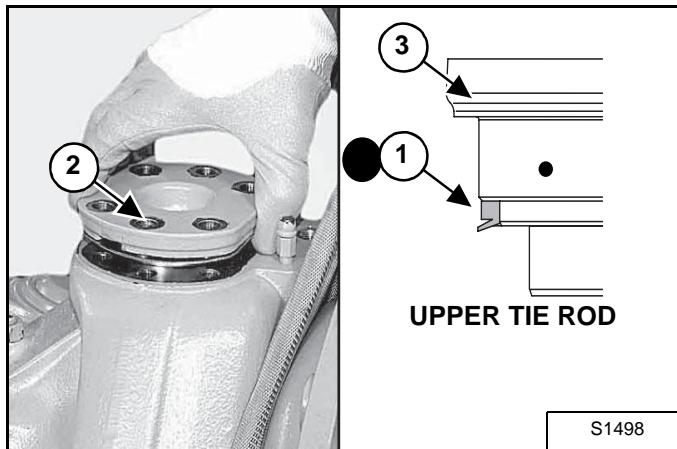

Install the seal (Item 1). Make sure the seal (Item 1) [Figure 40-22-157] is orientated as shown in the inset. Lubricate the pivot pin (Item 3) and the seal (Item 1) [Figure 40-22-157]. Install the pivot pin (Item 3) and the six bolts (Item 2) [Figure 40-22-157]. (Bolts not shown in photo.) Tighten the bolts to 103 ft.-lb. (140 Nm) torque.

Figure 40-22-158

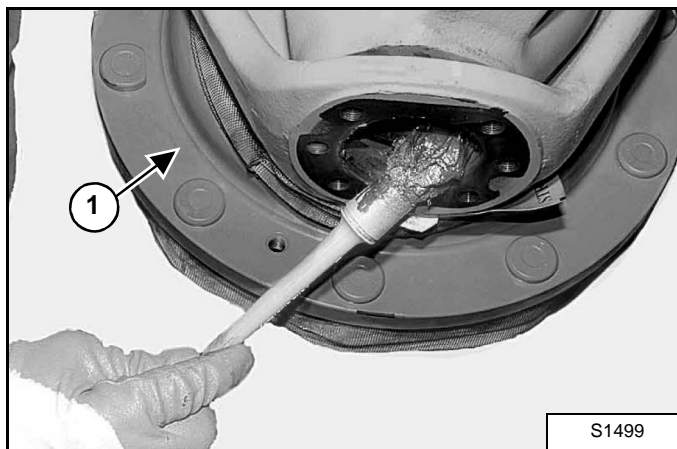

Lubricate the group with grease and mount it in the steering case (Item 1) [Figure 40-22-158].

Figure 40-22-159

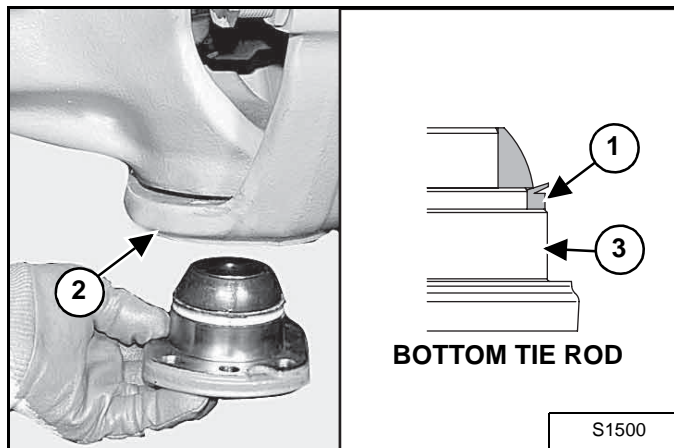

Install the seal (Item 1). Make sure the seal (Item 1) [Figure 40-22-159] is orientated as shown in the inset. Lubricate the pivot pin (Item 3) and the seal (Item 1) [Figure 40-22-159]. Install the pivot pin (Item 3) and the six bolts (Item 2) [Figure 40-22-159]. (Bolts not shown in photo.) Tighten the bolts to 103 ft.-lb. (140 Nm) torque.

Figure 40-22-160

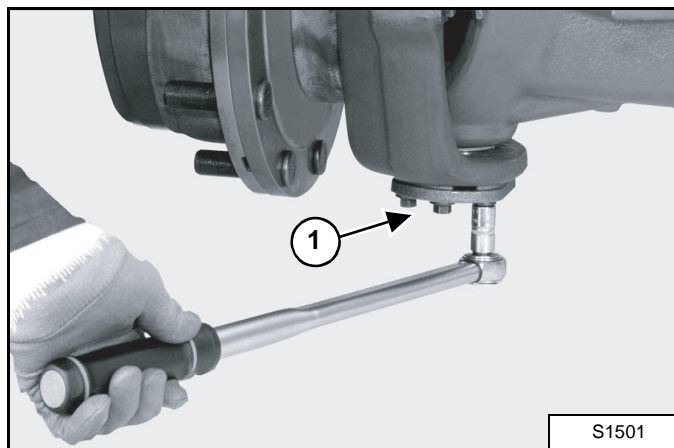

Tighten the fitting screws (Item 1) [Figure 40-22-160] of the bottom tie rod in sequence using the cross tightening method, apply a torque of 103 ft.-lb. (140 Nm).

AXLE AND DIFFERENTIAL (REAR) (For S/N 362812001 and Above, S/N 362912001 and Above) (CONT'D)

Planetary Carrier Disassembly (Cont'd)

Figure 40-23-5

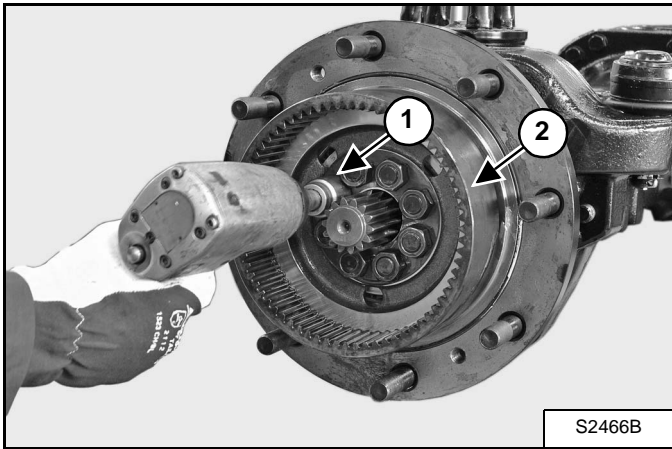

Remove the nuts (Item 1) from the ring gear support (Item 2) [Figure 40-23-5].

Figure 40-23-6

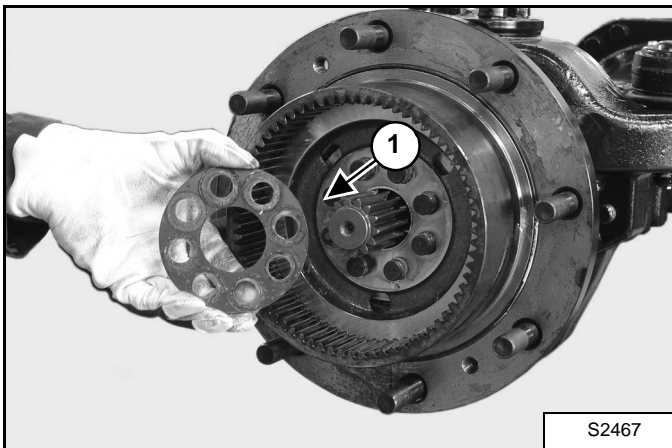

Remove the locking plate (Item 1) [Figure 40-23-6].

Figure 40-23-7

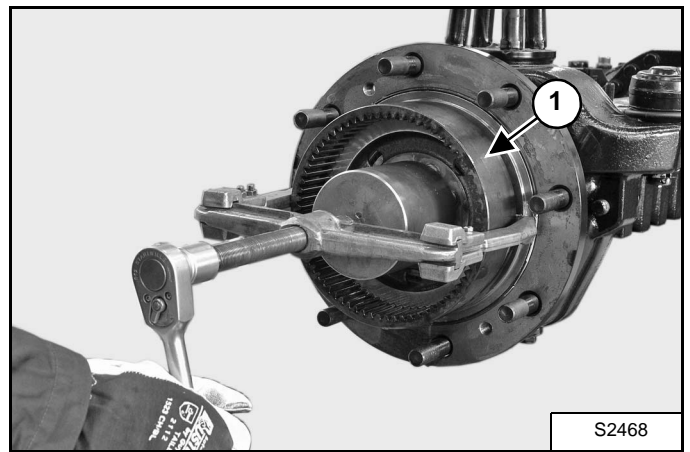

Using a puller, remove the complete ring gear (Item 1) [Figure 40-23-7] by acting on the stud bolts.

Figure 40-23-8

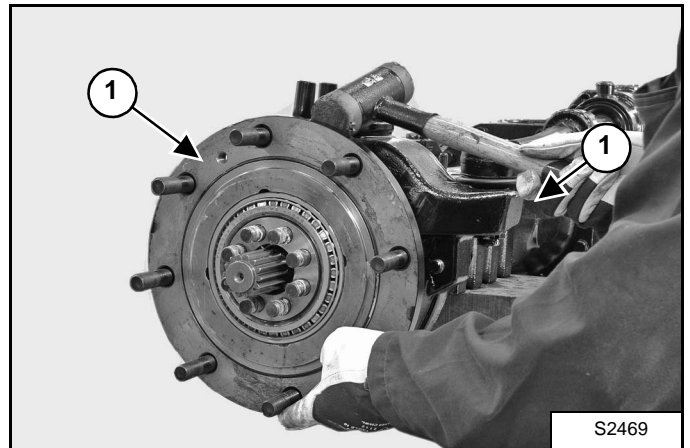

Partially extract the wheel hub (Item 1) [Figure 40-23-8] using a plastic hammer.

NOTE: Alternately hammer on several equidistant points.

AXLE AND DIFFERENTIAL (REAR) (For S/N 362812001 and Above, S/N 362912001 and Above) (CONT'D)

Differential Disassembly (Cont'd)

Figure 40-23-33

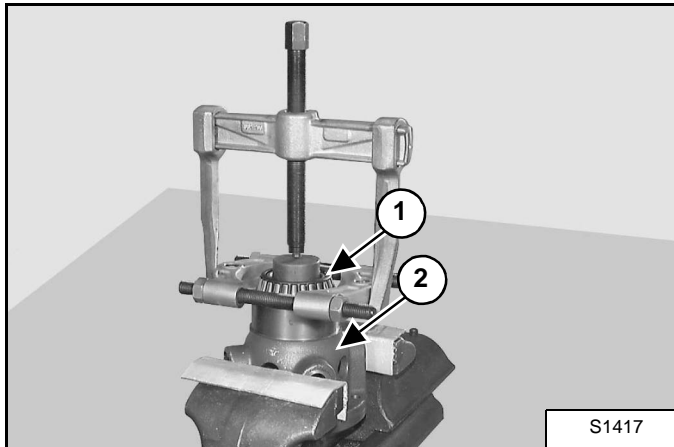

If the bearing needs to be replaced, extract the bearing (Item 1) from the differential carrier (Item 2) [Figure 40-23-33].

Figure 40-23-34

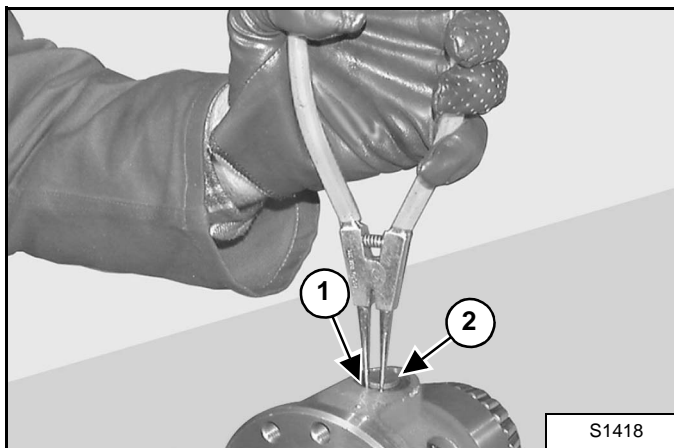

Remove the snap rings (Item 1) from the four pins (Item 2) [Figure 40-23-34] of the planet wheel gears.

Figure 40-23-35

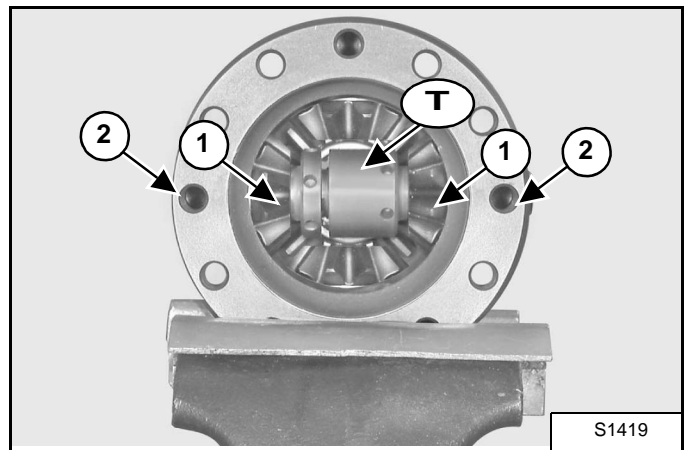

Insert a tool tool T between two planet wheel gears (Item 1) [Figure 40-23-35].

NOTE: Make sure that the tool is perfectly lined up with the pins (Item 1) [Figure 40-23-35] when locked.

Figure 40-23-36

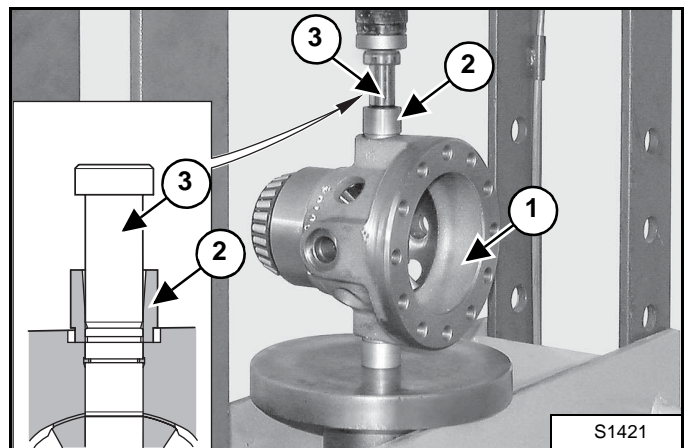

Place the differential carrier (Item 1) under a press, position a bushing (Item 2) and insert a pin (Item 3) [Figure 40-23-36]. Press the pin of the upper planet wheel gear into the tool T [Figure 40-23-35].

AXLE AND DIFFERENTIAL (REAR) (For S/N 362812001 and Above, S/N 362912001 and Above) (CONT'D)

Bevel pinion Assembly (Cont'd)

Figure 40-23-72

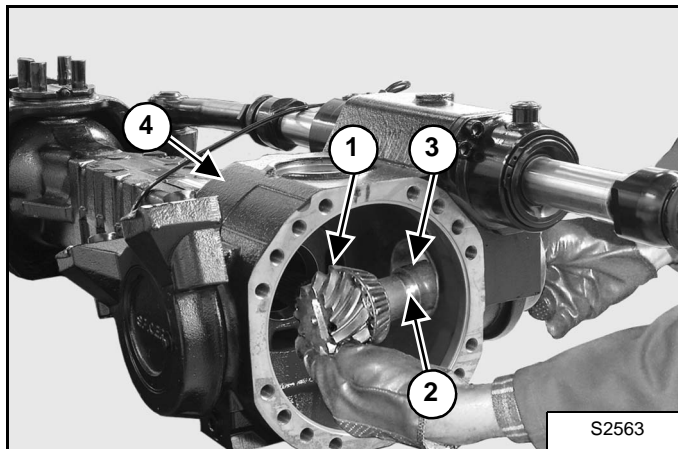

Fit the pinion (Item 1), shim "S1" (Item 2) and the distance piece (Item 3) in the main body (Item 4) [Figure 40-23-72].

NOTE: The finer shims must be placed in between the thicker ones.

Figure 40-23-73

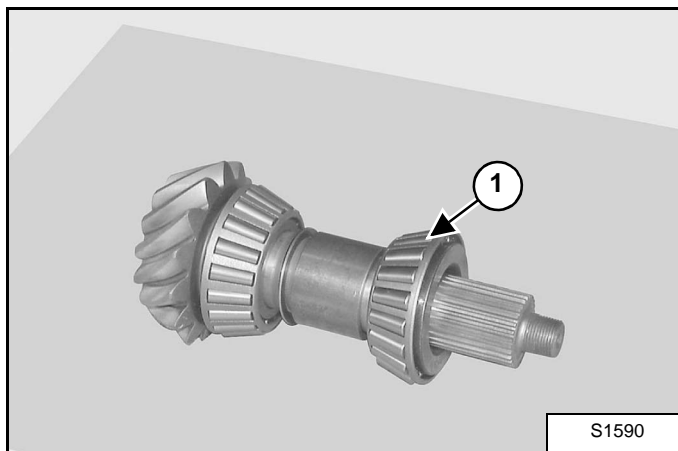

Insert the external bearing (Item 1) [Figure 40-23-73] in the central body in order to complete the pack arranged as in the figure.

Figure 40-23-74

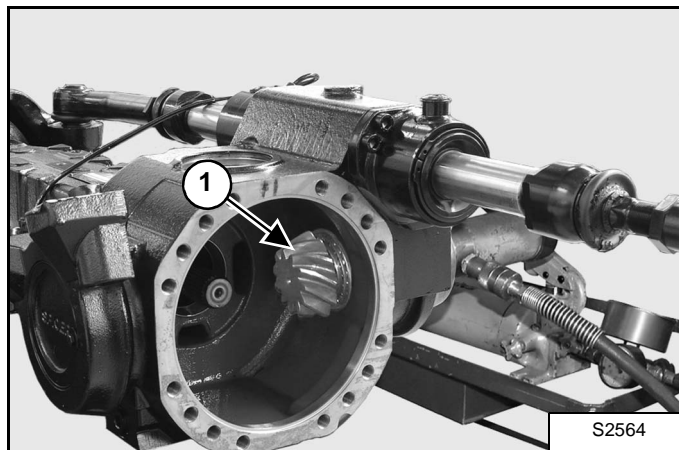

Connect the pinion (Item 1) [Figure 40-23-74] to the tie rod **T28A** and **T28B**. Connect the tie rod **T28C** to the press and block.

Figure 40-23-75

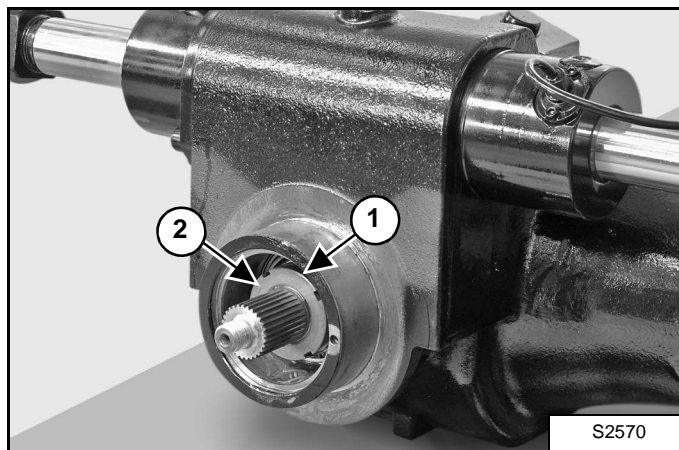

Apply Loctite 242 to the thread of the ring nut (Item 1) and screw the nut onto the pinion (Item 2) [Figure 40-23-75].

AXLE AND DIFFERENTIAL (REAR) (For S/N 362812001 and Above, S/N 362912001 and Above) (CONT'D)

Steering Knuckle Assembly (Cont'd)

Figure 40-23-108

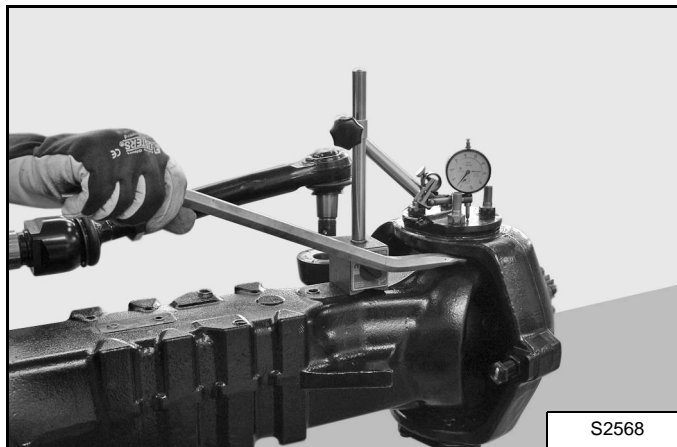

Install a magnetic based dial indicator on the steering housing. Check by means of a lever that there is no vertical gap. In case there is any gap, determine the width and reduce it by removing shims.

Figure 40-23-109

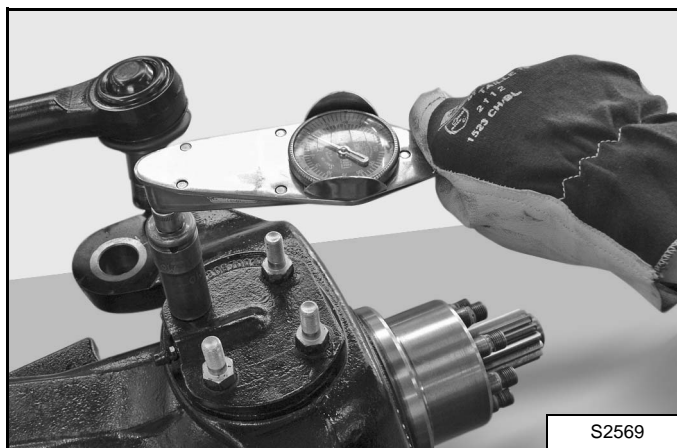

Check the torque of the pins, which has to be between 22 - 44 ft.-lb. (30 - 60 Nm). If the preliminary measured value is too high, the shims have to be increased.

FRONT AXLE WITHOUT FRAME LEVELING (CONT'D)

Removal (Cont'd)

Figure 40-30-17

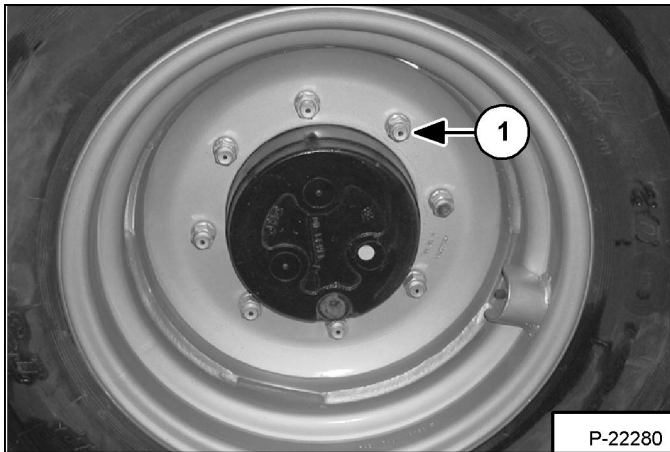

Remove the eight lug nuts and washers (Item 1) [Figure 40-30-17] from each front tire.

Remove both front tires.

Figure 40-30-18

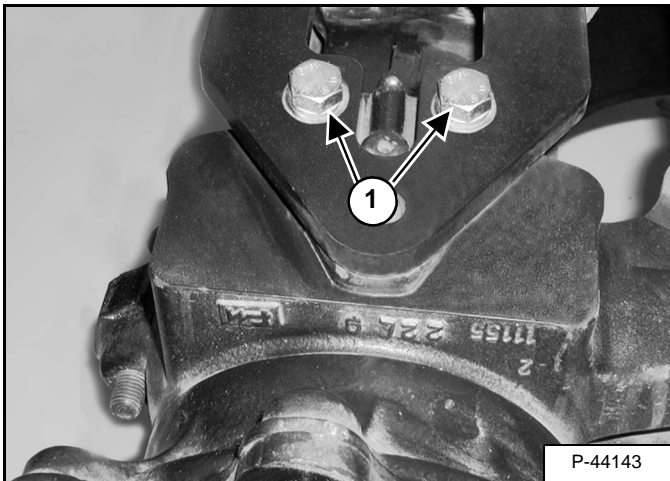

Remove the two bolts (Item 1) [Figure 40-30-18] and remove the front fenders.

Figure 40-30-19

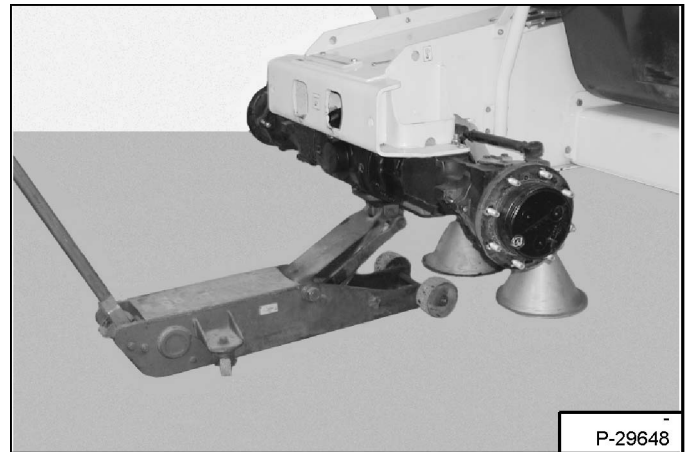

Using a floor jack, apply upward pressure to lift and support the front axle [Figure 40-30-19].

Figure 40-30-20

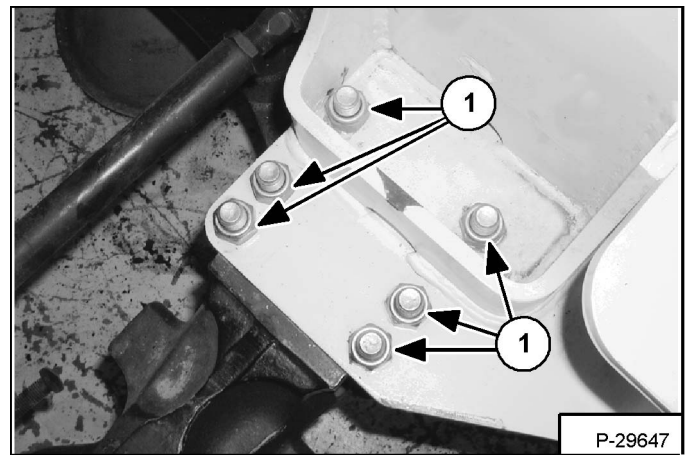

Remove the six axle mounting bolts (Item 1) [Figure 40-30-20] from each side of the axle.

FRONT AXLE WITH FRAME LEVELING (For S/N 362811001 - 362812000, S/N 362911001 - 362912000) (CONT'D)

Removal (Cont'd)

Figure 40-31-8

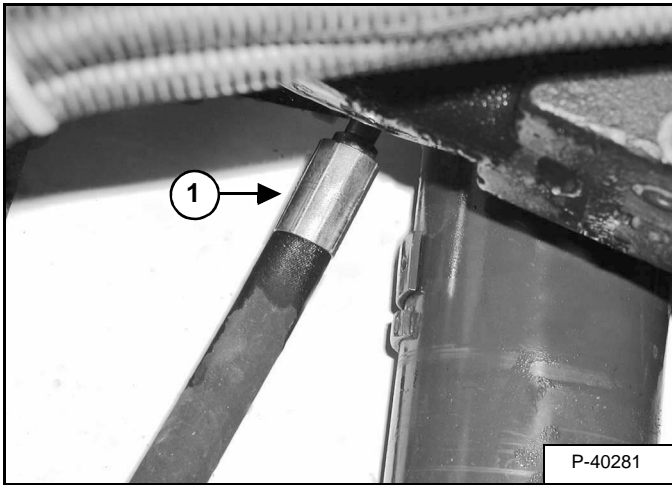

Remove the hose (Item 1) [Figure 40-31-8] from the bottom of the drive motor.

Figure 40-31-9

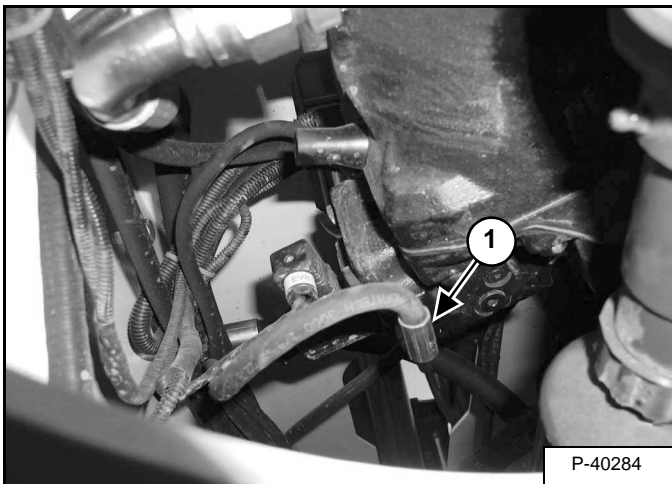

Remove the hose (Item 1) [Figure 40-31-9] from the bottom of the drive motor.

Figure 40-31-10

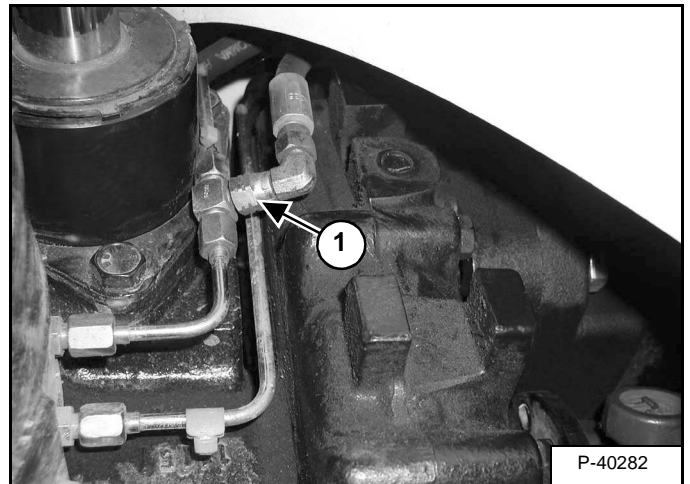

Remove the brake hose (Item 1) [Figure 40-31-10] from the left side of the axle.

Figure 40-31-11

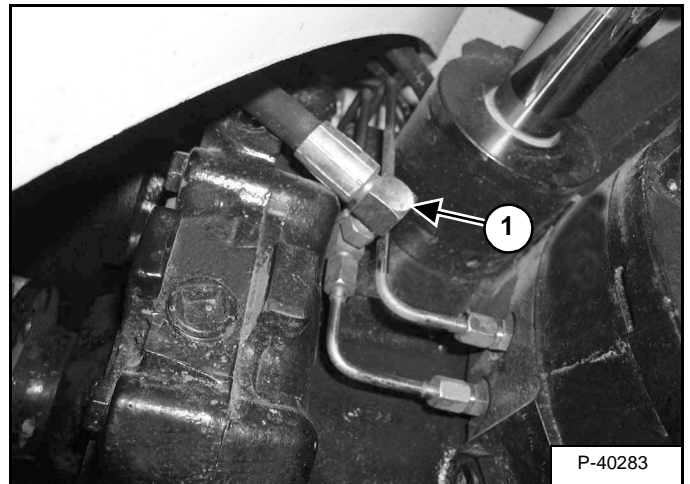

Remove the brake hose (Item 1) [Figure 40-31-11] from the right side of the axle.

AXLE PIVOT FRAME (Only For S/N 362811001 - 362812000, S/N 362911001 - 362912000)

Removal And Installation

Remove the front axle. (See "Removal" on page 40-31-1 for machine with Frame Leveling) or (See "Removal" on page 40-30-1 for machine without Frame Leveling)

Figure 40-32-1

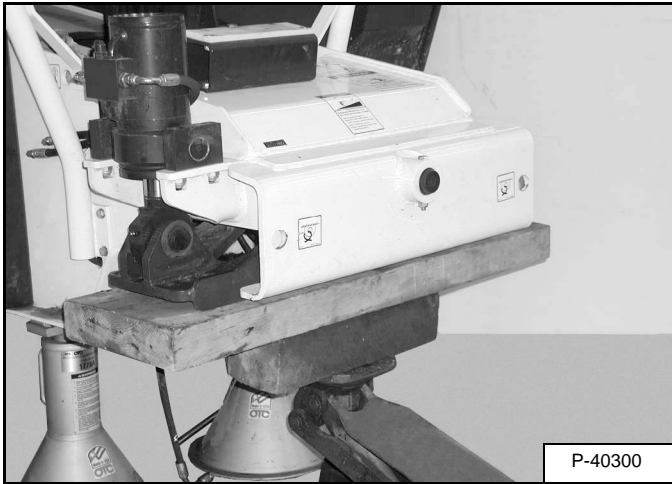

Support the pivot with blocks and a jack [Figure 40-32-1].

Figure 40-32-2

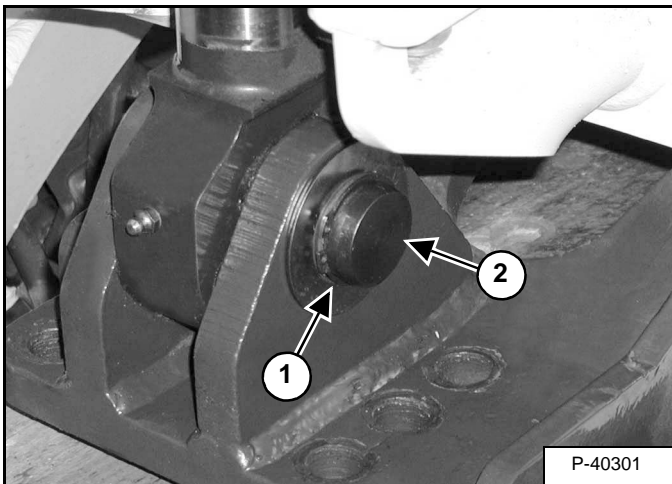

Remove the snap ring (Item 1) and washer from the rod end pivot pin (Item 2) [Figure 40-32-2] of the leveling cylinder.

Remove the pivot pin.

Figure 40-32-3

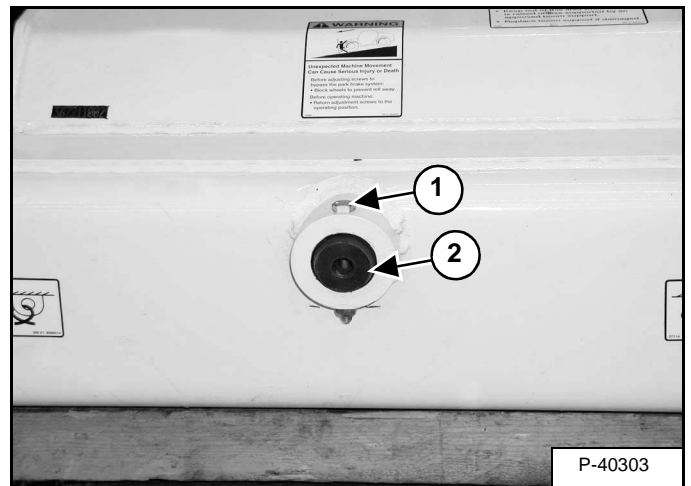

Remove the bolt (Item 1) and nut from the pivot pin (Item 2) [Figure 40-32-3]. Remove the pivot pin.

Figure 40-32-4

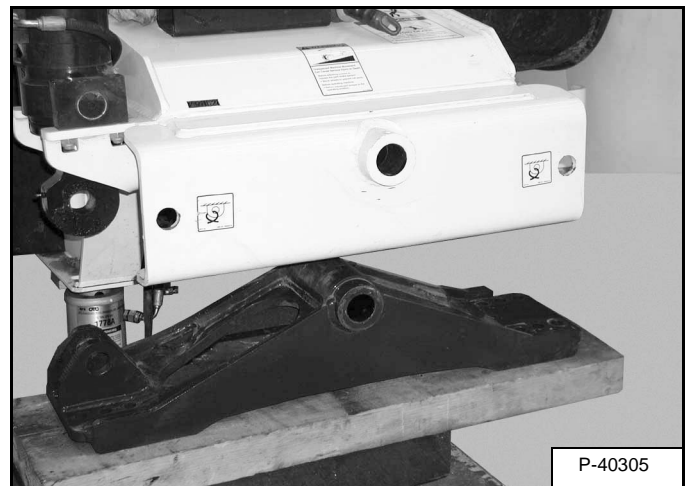

Slowly lower the jack and remove the pivot frame out from under the frame [Figure 40-32-4].

FRONT AXLE (For S/N 362812001 and Above, S/N 362912001 and Above) (CONT'D)

Installation (Cont'd)

Figure 40-33-32

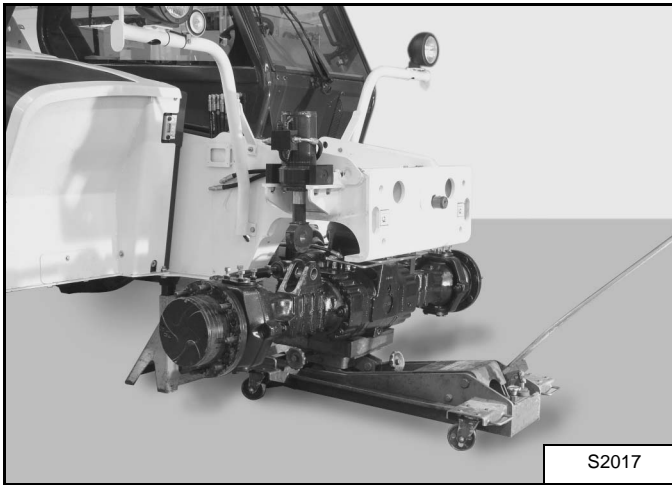

Gently raise the jack.

Figure 40-33-33

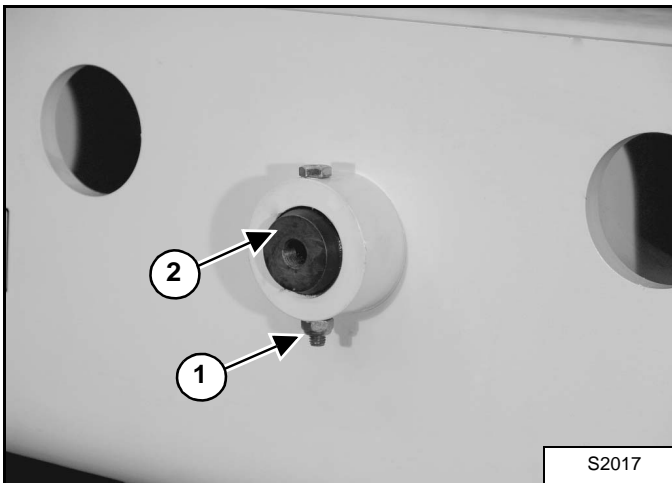

Install the bolt (Item 1) and nut from the pivot pin (Item 2) [Figure 40-33-33].

Figure 40-33-34

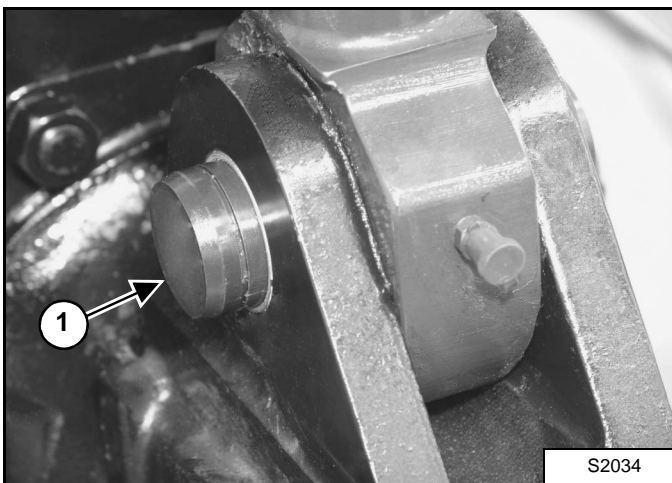

Install the snap ring and washer. Remove the pivot pin (Item 1) [Figure 40-33-34].

Figure 40-33-35

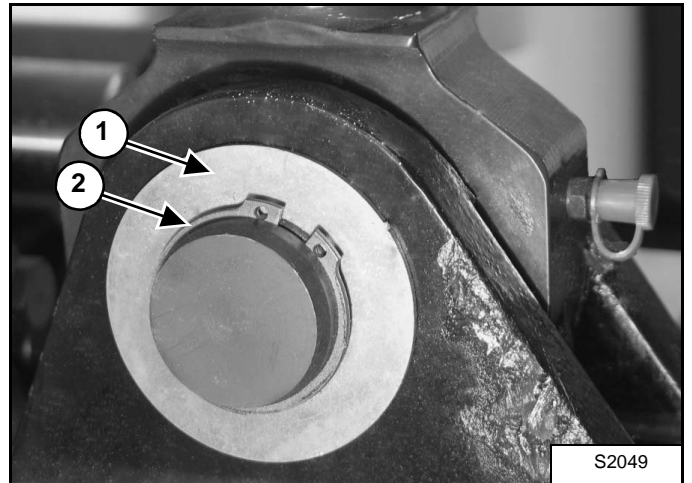

Install the washer (Item 1) and snap ring (Item 2) [Figure 40-33-35].

PARKING BRAKE (For S/N 362811001 - 362812000, S/ N 362911001 - 362912000)

Preparing for towing

The Telescopic Handler can be towed a short distance such as removing it from mud or loading onto a transport vehicle.

The machine must be prepared before towing.

! WARNING

- Before towing, the machine must be immobilised using chocks in front of the wheels or any other means independent of the machine. Do not apply the handbrake.
- After this operation, the handbrake will not work and it will no longer be possible to lock the machine with the hydrostatic transmission.

Disengaging the hydrostatic transmission

It is impossible for oil to circulate in a hydrostatic transmission in a closed circuit when the machine is not running, this operation involves making oil circulation possible:

Figure 10-40-1

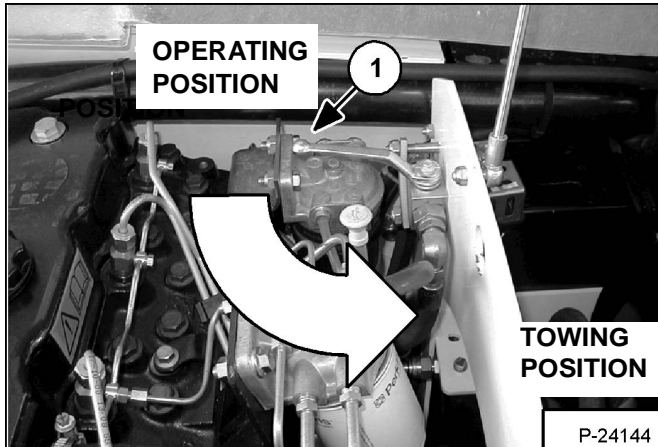

If the optional tow valve is installed, simply raise the engine cover and turn the valve counterclockwise 90° (Item 1) [Figure 10-40-1] to TOWING POSITION.

Follow the below procedure if the optional tow valve is not installed:

Figure 10-40-2

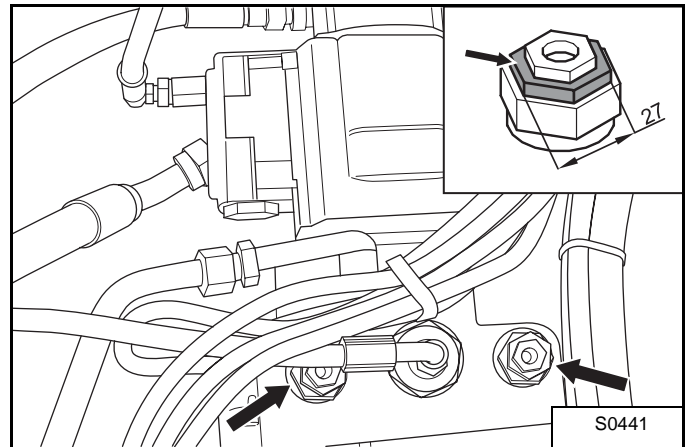

- Locate the two identical multi-function valves on the hydrostatic transmission pump [Figure 10-40-2]. Each valve has three 6-sided nuts of different sizes.
- Unscrew the middle screw of each valve 2.5 turns. This action will bypass the oil flow from the hydrostatic transmission.

SERVICE BRAKE (For S/N 362811001 - 362812000, S/N 362911001 - 362912000)

Description

There are two bleed screws located on each side of the front axle differential housing.

Air trapped in the brake lines may cause a spongy feel and/or delayed activation of the service brake.

Use the following procedure to remove air from the brake circuit.

Bleeding The Brake Circuit

Lift and block the machine. (See "LIFTING AND BLOCKING THE Telescopic Handler" on page 10-10-1)

NOTE: Position the jackstands to allow starting the machine and driving the wheels.

Figure 40-80-1

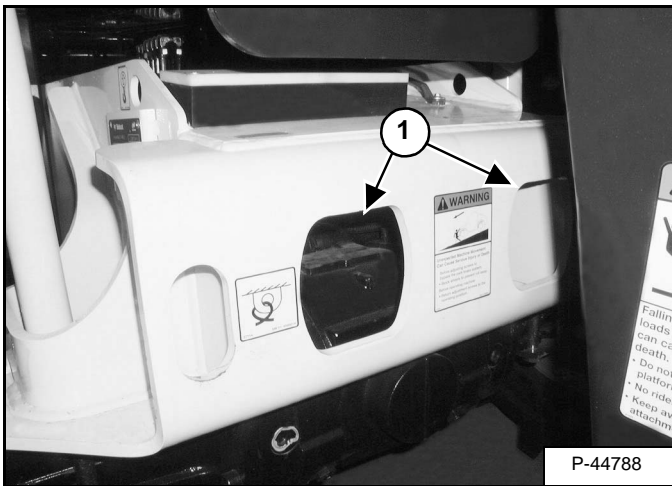

On machines without frame leveling the bleed screws are accessible through the holes (Item 1) [Figure 40-80-1] in the main frame.

Figure 40-80-2

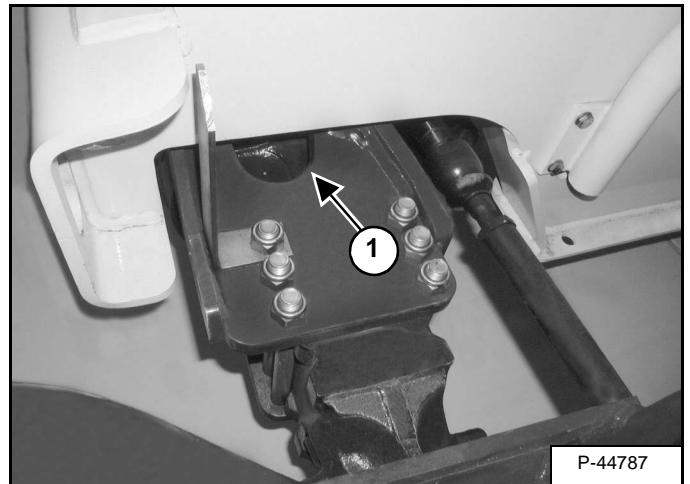
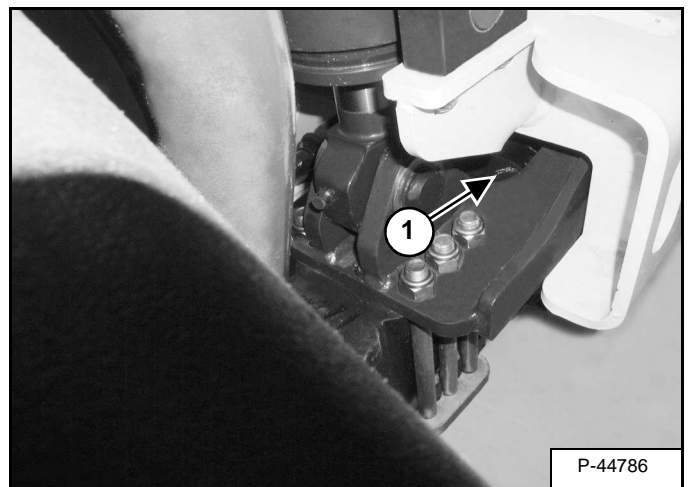

Figure 40-80-3



On machines with frame leveling the bleed screws are accessible through the holes (Item 1) [Figure 40-80-2] and [Figure 40-80-3] on each side of the pivot frame.

REAR AXLE (For S/N 362811001 - 362812000, S/N 362911001 - 362912000) (CONT'D)

Installation (Cont'd)

Figure 40-90-24

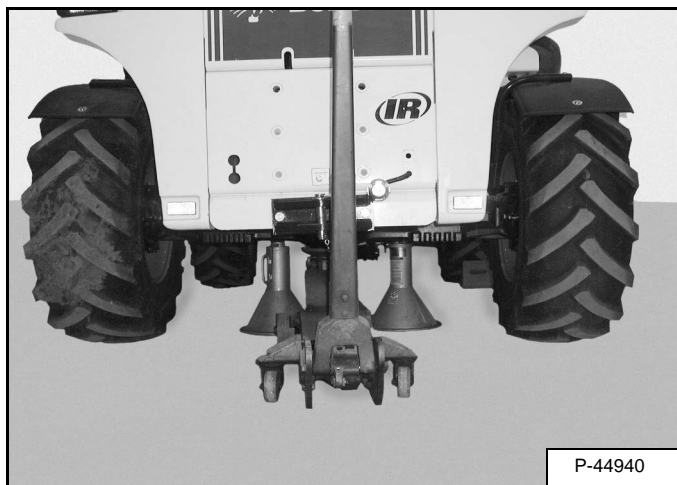

Raise the machine and remove the jackstands. Lower the machine and remove the blocks from the front tire **[Figure 40-90-24]**.

Figure 40-90-25

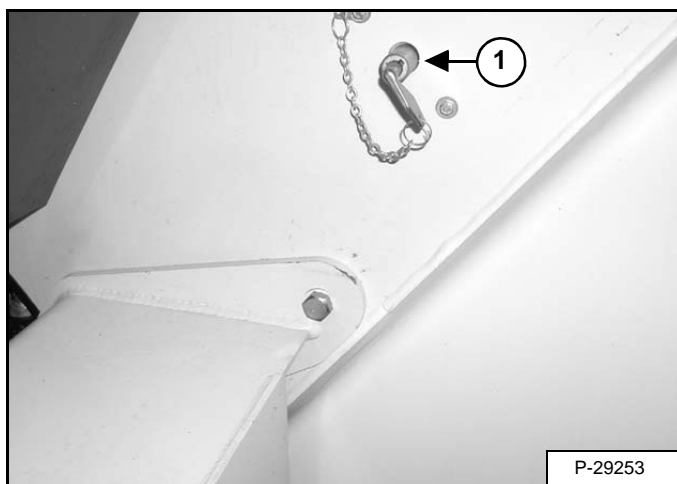

Rotate the battery disconnect switch (Item 1) **[Figure 40-90-25]** to the left, to restore the power supply from the battery.

MAIN FRAME

AIR INTAKE COWLING	50-71-1
Removal And Installation.	50-71-1
BOOM ASSEMBLY.	50-30-1
Removal And Installation.	50-30-1
DASH COVER/STEERING COLUMN COVER	50-130-1
Removal And Installation.	50-130-1
ENGINE COVER	50-70-1
Gas Cylinder Removal And Installation.	50-70-1
Removal And Installation.	50-70-1
FENDER.	50-110-1
Removal And Installation.	50-110-1
FUEL TANK	50-80-1
Removal And Installation.	50-80-1
INNER BOOM.	50-40-1
Installation	50-40-3
Removal	50-40-1
JOYSTICK PANEL	50-140-1
Removal And Installation.	50-140-1
OPERATOR CAB	50-10-1
Removal and Installation.	50-10-1
OPERATOR SEAT	50-20-1
Not available at time of printing.	50-20-1
PIVOT LINK	50-120-1
Removal And Installation.	50-120-1
QUICK TACH	50-90-1
Removal And Installation.	50-90-1
REAR WEIGHTS	50-100-1
Removal And Installation.	50-100-1
WEAR PADS (FRONT).	50-50-1
Removal And Installation.	50-50-1
WEAR PADS (REAR).	50-60-1
Installation	50-60-1
Removal	50-60-1



OPERATOR SEAT

Not available at time of printing

WEAR PADS (FRONT)

Removal And Installation

Figure 50-50-16

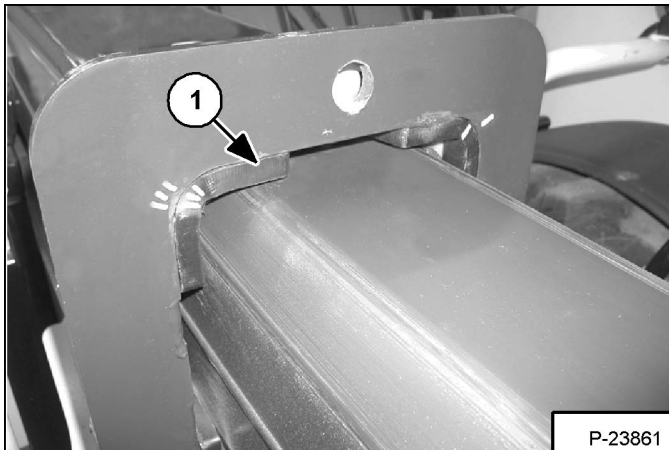

Extend the inner boom approximately 2 ft. (610 mm) and mark the location of the inner supports and wear pads (Item 1) [Figure 50-50-16].

Figure 50-50-17

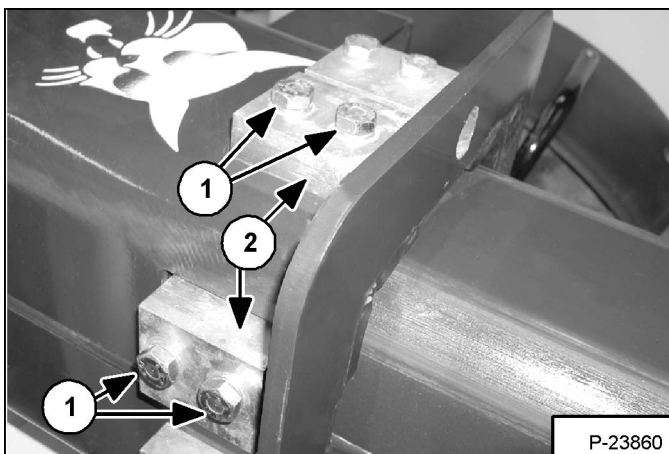

Remove the four bolts (Item 1) and two blocks (Item 2) [Figure 50-50-17] from the boom.

Installation: Tighten the bolts to 58 ft.-lbs. (43 Nm).

Figure 50-50-18

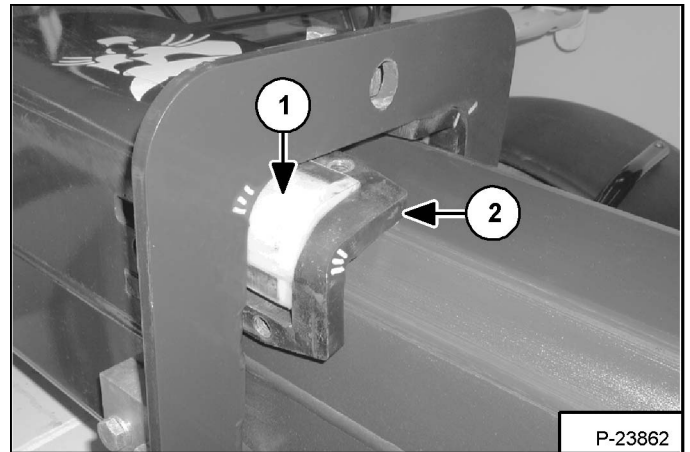

Remove the wear pad (Item 1) and inner support (Item 2) [Figure 50-50-18].

With both upper wear pads removed, use a hoist and lifting strap at the end of the boom, apply upwards pressure, lifting the inner boom off the bottom wear pads.

Figure 50-50-19

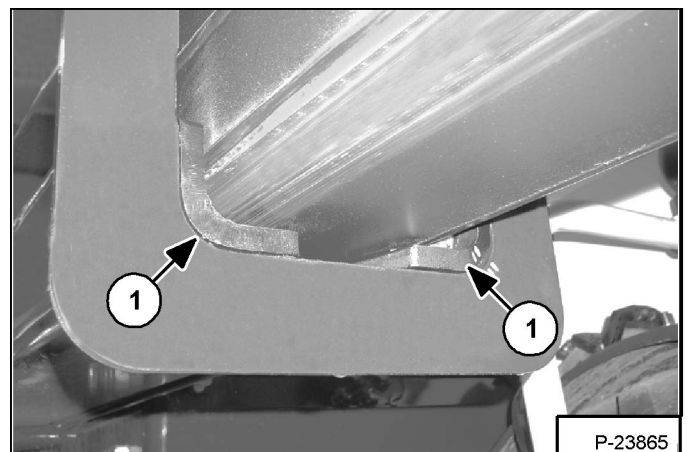

Remove the bottom wear pads (Item 1) [Figure 50-50-19].

FUEL TANK (CONT'D)

Removal And Installation (Cont'd)

Figure 50-80-9

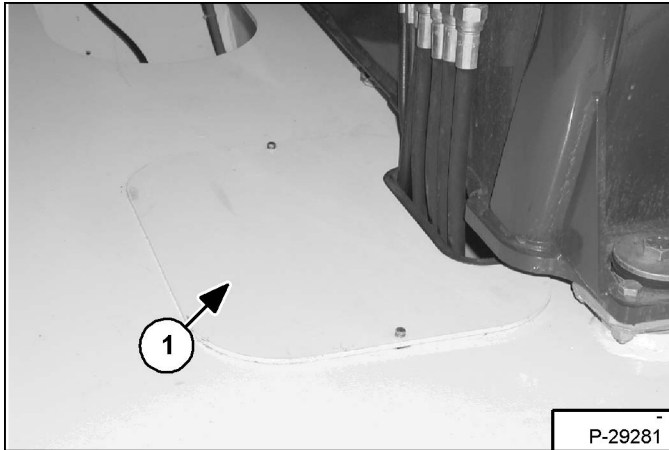

Remove the access panel (Item 1) [Figure 50-80-9].

Figure 50-80-10

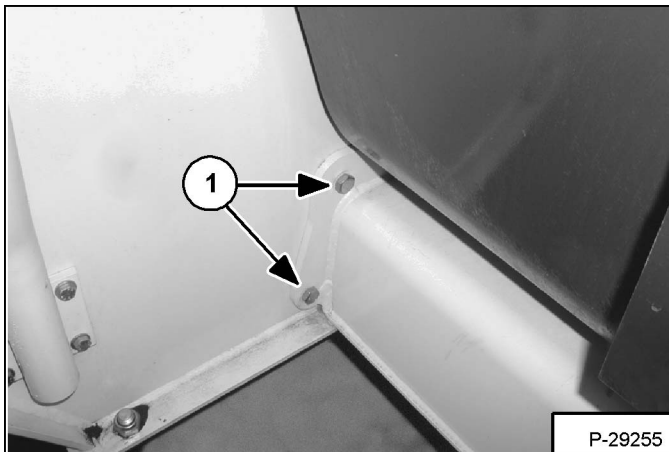

Remove the two mounting bolts (Item 1) [Figure 50-80-10] from the front of the fuel tank.

Figure 50-80-11

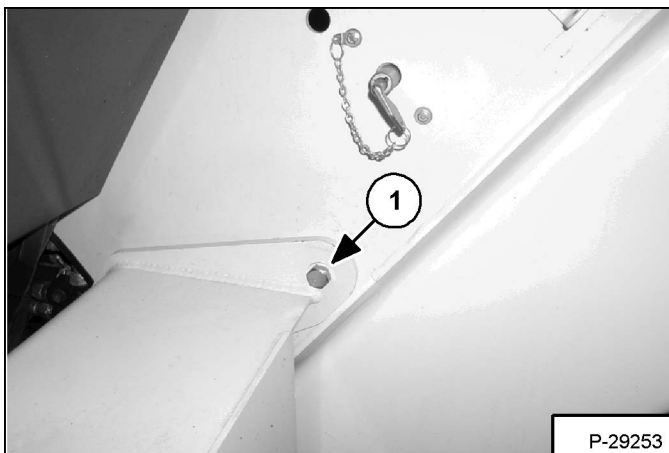
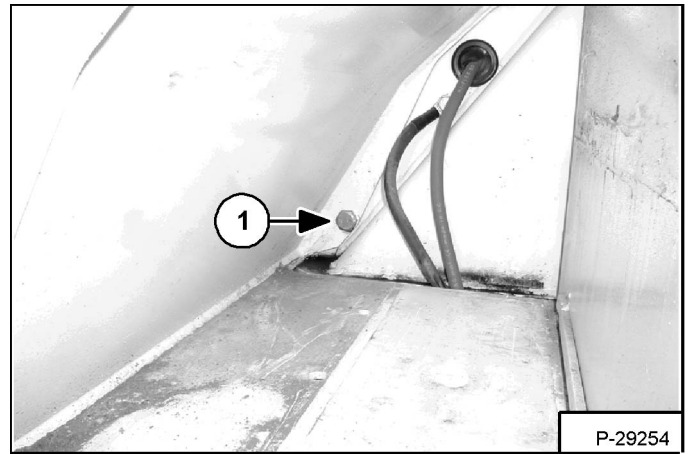

Figure 50-80-12



Remove the mounting bolts (Item 1) [Figure 50-80-11] & [Figure 50-80-12] from the rear of the fuel tank.

PIVOT LINK (CONT'D)

Removal And Installation (Cont'd)

Figure 50-120-9

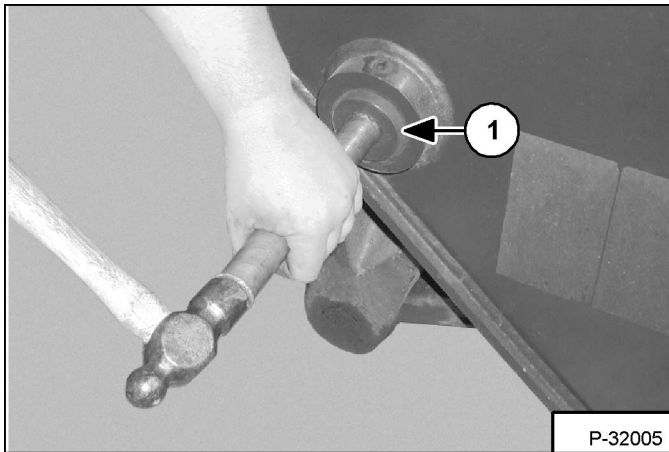

Remove the pivot pin (Item 1) [Figure 50-120-9].

Figure 50-120-10

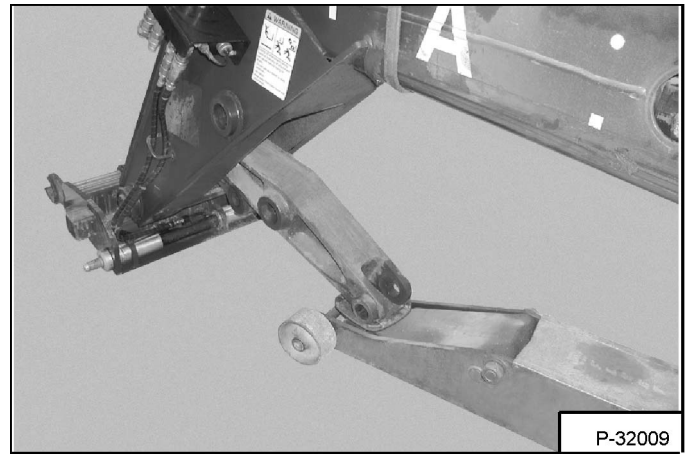

Lower the floor jack and remove the pivot link [Figure 50-120-10].

ELECTRICAL SYSTEM INFORMATION

Troubleshooting Chart

The following troubleshooting chart is provided for assistance in locating and correcting problems which are most common. Many of the recommended procedures must be done by authorized Bobcat Service Personnel only.



Instructions are necessary before operating or servicing machine. Read and understand the Operation & Maintenance Manual, Handbook and signs (decals) on machine. Follow warnings and instructions in the manuals when making repairs, adjustments or servicing. Check for correct function after adjustments, repairs or service. Untrained operators and failure to follow instructions can cause injury or death.

W-2003-0199

PROBLEM	CAUSE
Battery will not take charge.	1, 2, 3, 4, 5
Alternator will not charge.	1, 2, 5
Starter will not turn the engine.	2, 3, 4, 6, 7, 8, 9

KEY TO CORRECT THE CAUSE
1. Alternator belt is loose or damaged.
2. Battery connections are dirty or loose.
3. Battery is damaged.
4. The ground connection is not making a good contact.
5. The alternator is damaged
6. The engine is locked.
7. The starter is damaged.
8. The wiring or the solenoid is damaged.
9. Check the fuses.

ALTERNATOR

Removal And Installation

Figure 60-30-1

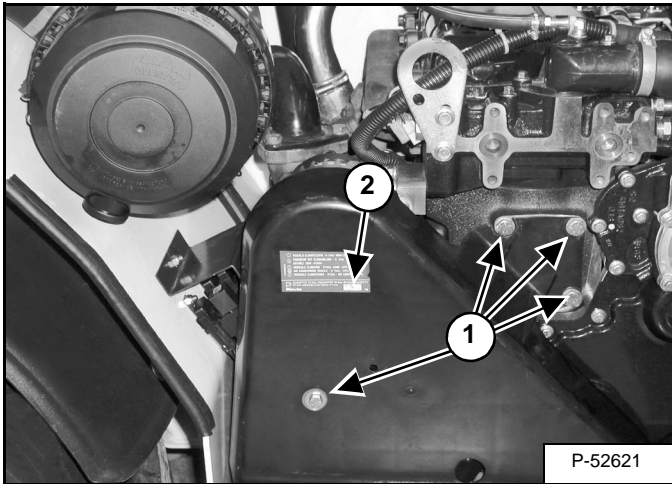

Open the engine cover.

Remove the four bolts (Item 1) and belt shield (Item 2) [Figure 60-30-1].

Figure 60-30-2

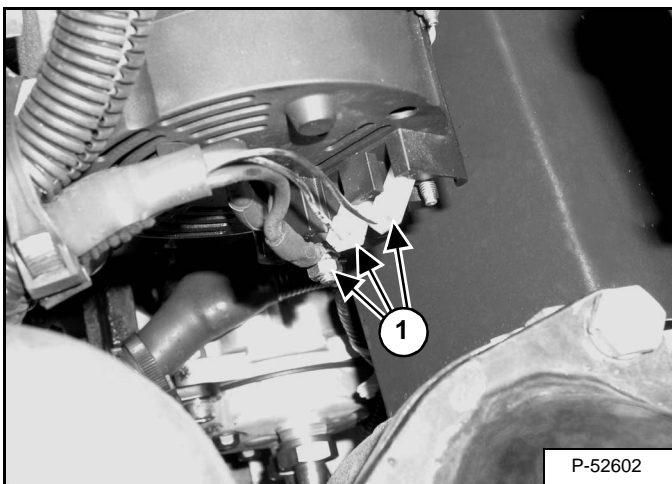

Remove the three connectors (Item 1) [Figure 60-30-2] from the back of the alternator.

Figure 60-30-3

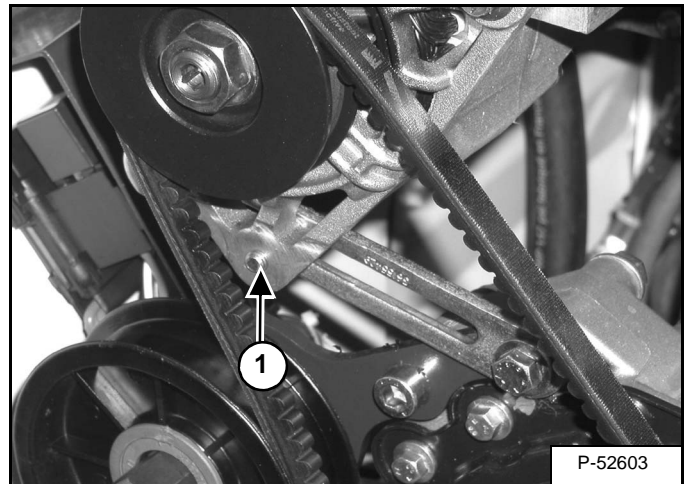

Loosen and remove the alternator adjusting bolt (Item 1) [Figure 60-30-3].

Figure 60-30-4

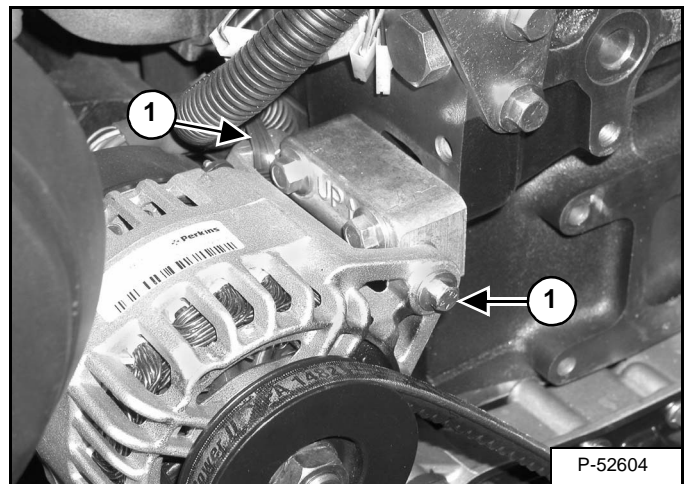

Loosen and remove both mounting bolts (Item 1) [Figure 60-30-4].

Remove the alternator.

INSTRUMENT PANEL

Removal And Installation

Figure 60-80-1

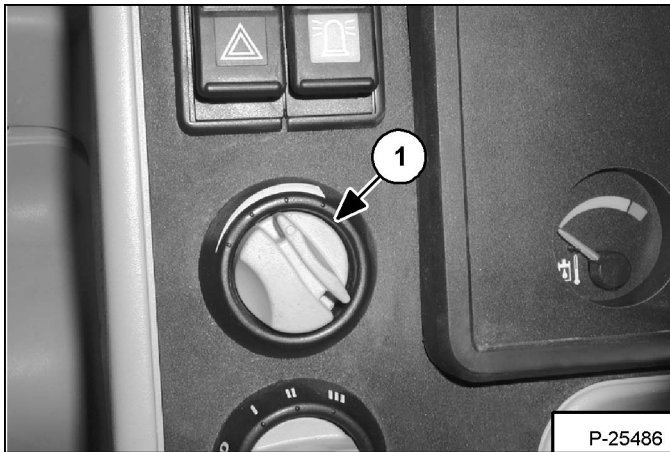

Remove the temperature control knob (Item 1) [Figure 60-80-1]. (If Equipped)

Figure 60-80-2

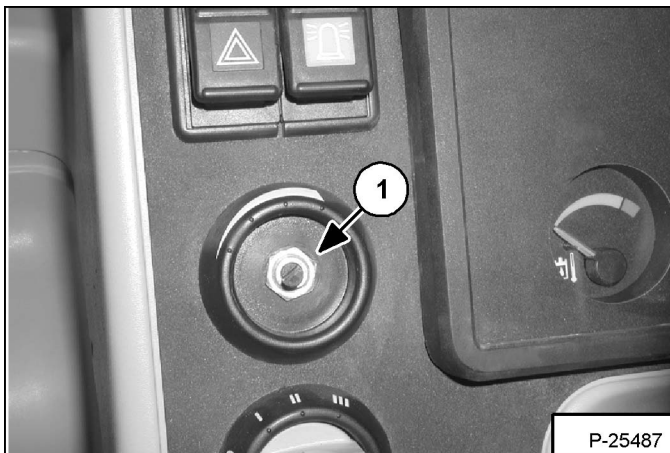

Remove the nut (Item 1) [Figure 60-80-2] letting the temperature controller fall inward.

Figure 60-80-3

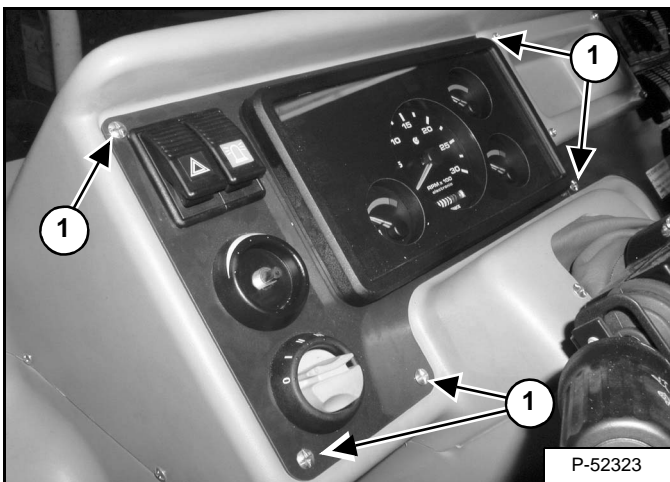

Remove the five instrument panel mounting bolts (Item 1) [Figure 60-80-3].

Figure 60-80-4

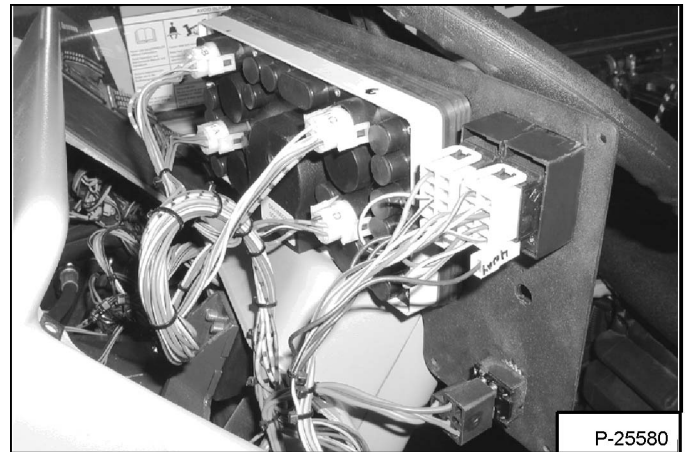

Tilt the instrument panel forward and unplug all connectors [Figure 60-80-4]. Remove the instrument panel.

NOTE: Mark the connectors for correct installation.

TOP WIPER MOTOR

Removal And Installation

Figure 60-120-1

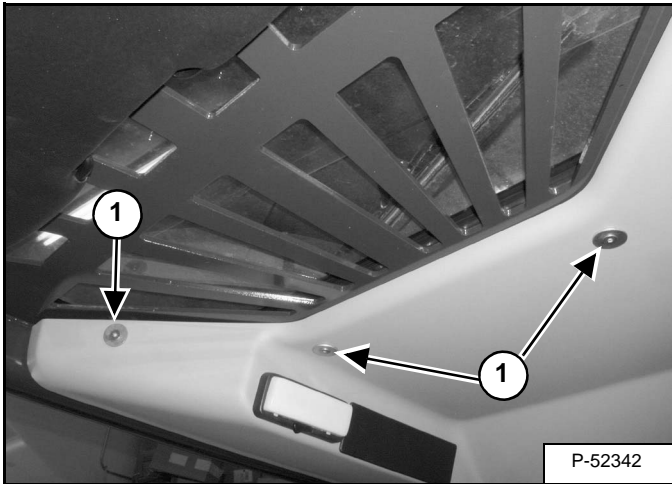

Remove the three screws (Item 1) [Figure 60-120-1] from the upper panel.

Figure 60-120-2



Slide the upper panel forward on the support rails [Figure 60-120-2].

Lower the panel.

Figure 60-120-3

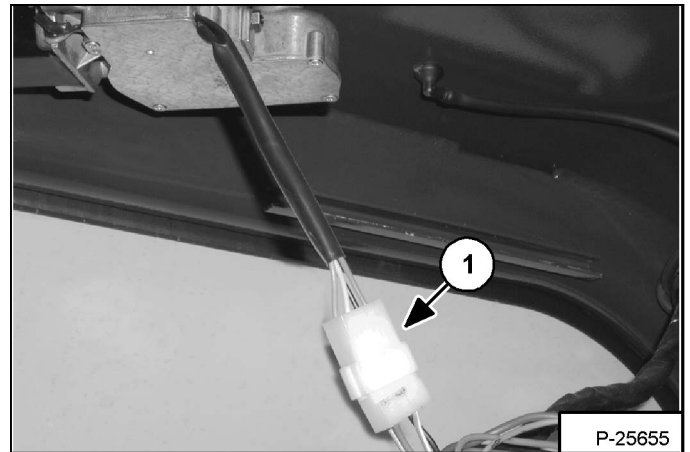

Unplug the wiper motor connector (Item 1) [Figure 60-120-3] from the harness.

Figure 60-120-4

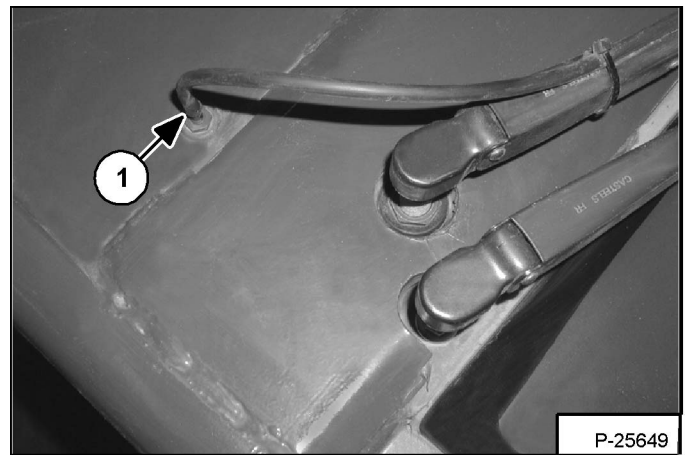

Remove the squirter tube (Item 1) [Figure 60-120-4].

INCHING SWITCH

Removal And Installation

Figure 60-160-1

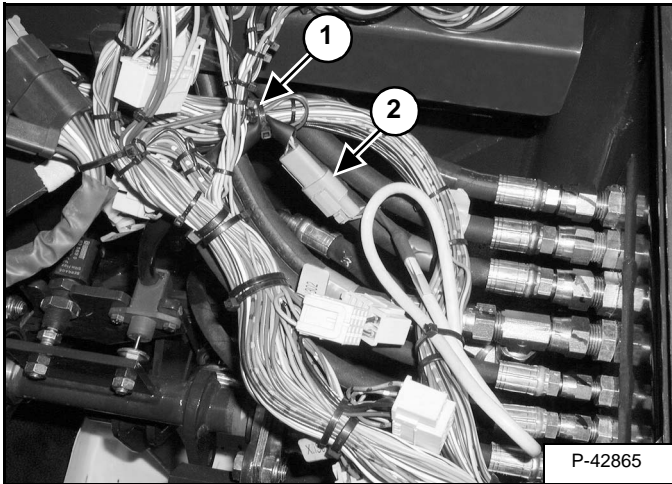

Remove the dash cover/column cover. (See "Removal And Installation" on page 50-130-1)

Remove the tie strap (Item 1) and unplug the switch connector (Item 2) [Figure 60-160-1] from the harness.

Figure 60-160-2

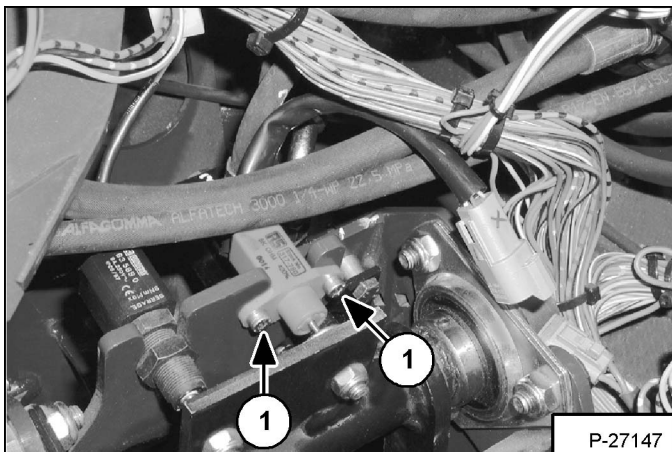

Remove the two mounting bolts and nuts (Item 1) [Figure 60-160-2].

Installation:

- Before installation, make sure that the 2 resistors (see electric diagram) are on the switch's wiring.
- Be sure the switch is on the front side of the mounting bracket.

Remove the switch.

Adjustment

Figure 60-160-3

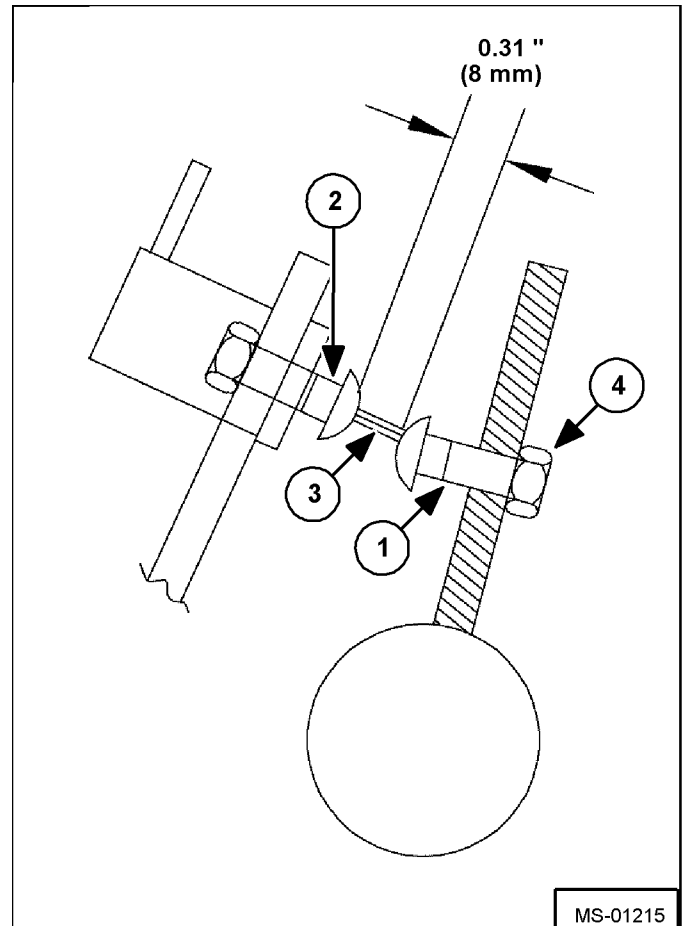

Remove the dash cover/column cover. (See "Removal And Installation" on page 50-130-1)

With the brake pedal in the rest position, turn the adjustment bolt (Item 1) so that it is 0.31 in. (8 mm) away from the switch body (Item 2) [Figure 60-160-3].

Check that the potentiometer rod (Item 3) [Figure 60-160-3] is in contact with the center of the adjusting bolt.

When adjustment is complete, tighten the nut (Item 4) [Figure 60-160-3] without turning the adjusting bolt.

FRAME LEVEL SPEED SWITCH (CONT'D)

Installation (Cont'd)

Figure 60-170-8

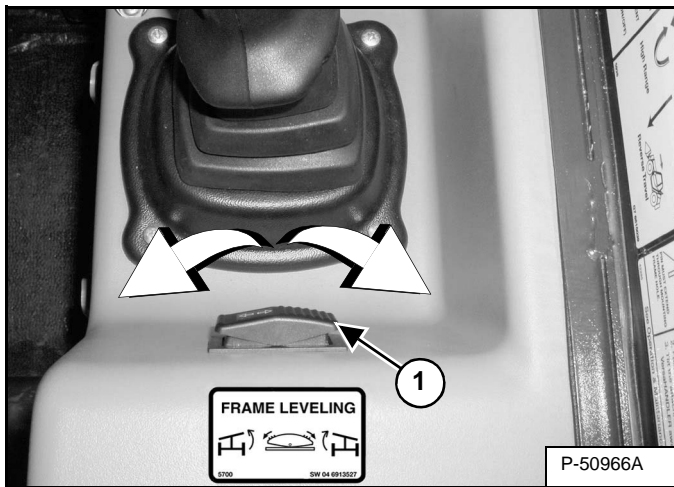

Start the engine.

While holding the frame leveling switch (Item 1) [Figure 60-170-8] raise the boom. When the boom reaches 25 degrees the speed of the frame leveling should decrease.

Disassembly And Assembly

Remove the frame level speed switch. (See "Removal" on page 60-170-1)

Figure 60-170-9

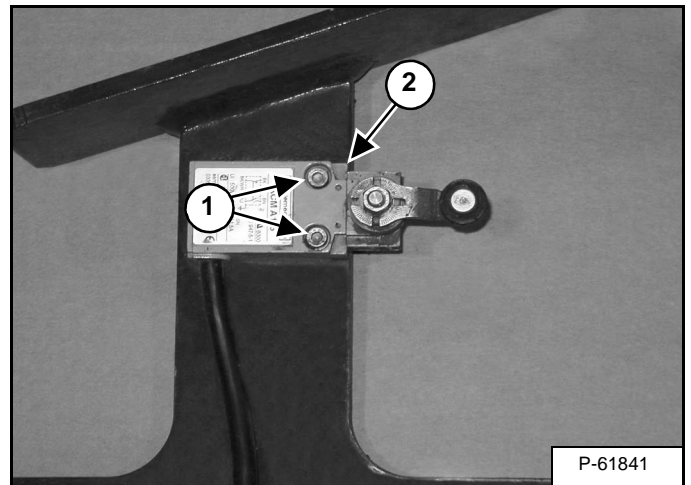

Remove the two bolts and nuts (Item 1) and remove the switch (Item 2) [Figure 60-170-9].

ENGINE SPEED CONTROL

Removal And Installation

Figure 70-20-1

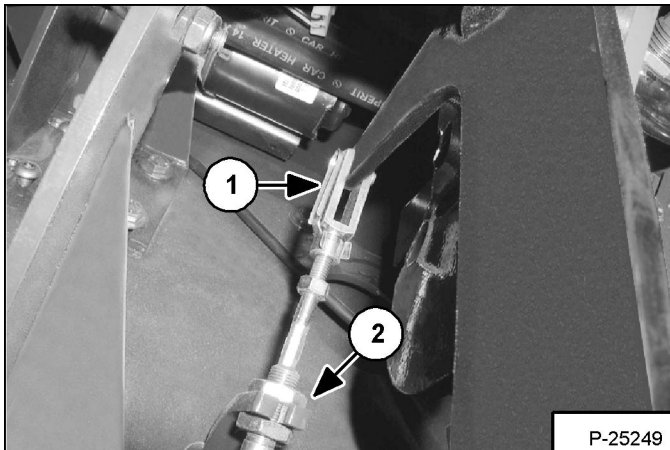

Remove the floor mat and insulation from the cab floor.

Remove the speed control cable (Item 1) from the pedal and mounting bracket (Item 2) [Figure 70-20-1].

Remove the battery box cover.

Figure 70-20-2

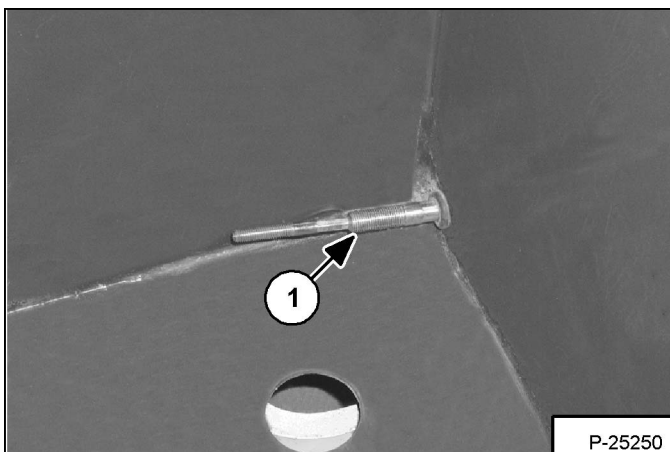

Carefully pull the speed control cable (Item 1) [Figure 70-20-2] through the cab and into the battery box.

Figure 70-20-3

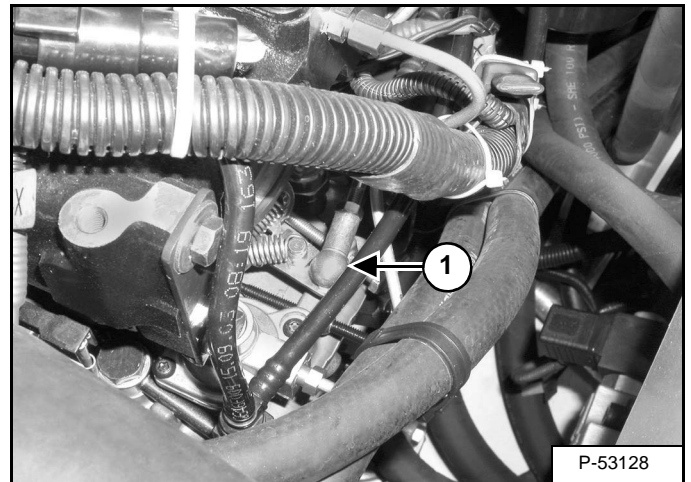

Open the engine cover.

Remove the engine speed control cable (Item 1) [Figure 70-20-3] from the linkage.

Figure 70-20-4

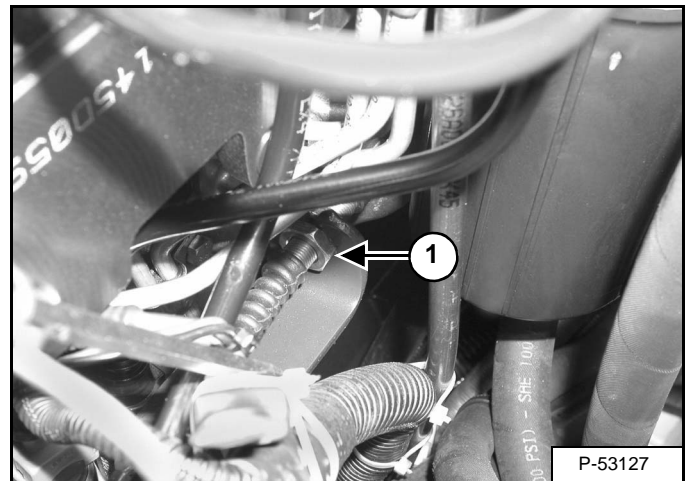

Remove the engine speed control cable from the mounting bracket (Item 2) [Figure 70-20-4].

Remove any necessary cable ties, carefully remove the speed control cable.

ENGINE AND ENGINE MOUNTS

Removal And Installation

Remove the engine/hydrostat assembly. (See "Removal And Installation" on page 70-80-1)

NOTE: Set the engine/hydrostat assembly on blocks, to allow access to remove the motor mount bolts.

Remove the hydrostatic pump. (See "Removal And Installation" on page 30-40-1)

Remove the flywheel and housing. (See "Removal And Installation" on page 70-90-1.)

If equipped with air conditioning, remove the hoses from the compressor. (See "Removal And Installation" on page 80-110-1)

Figure 70-60-1

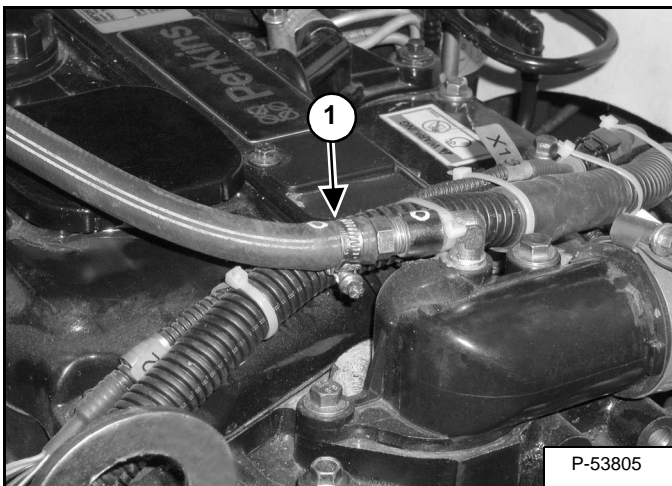

Remove the hose (Item 1) [Figure 70-60-1] from the thermostat housing.

Figure 70-60-2

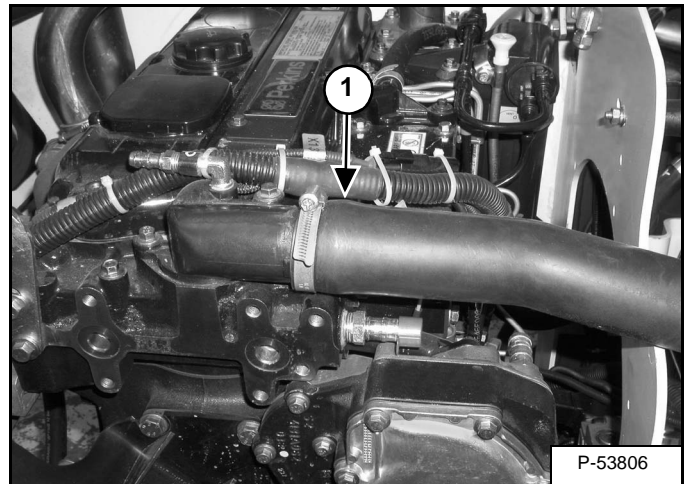

Remove the hose (Item 1) [Figure 70-60-2] and reposition.

Figure 70-60-3

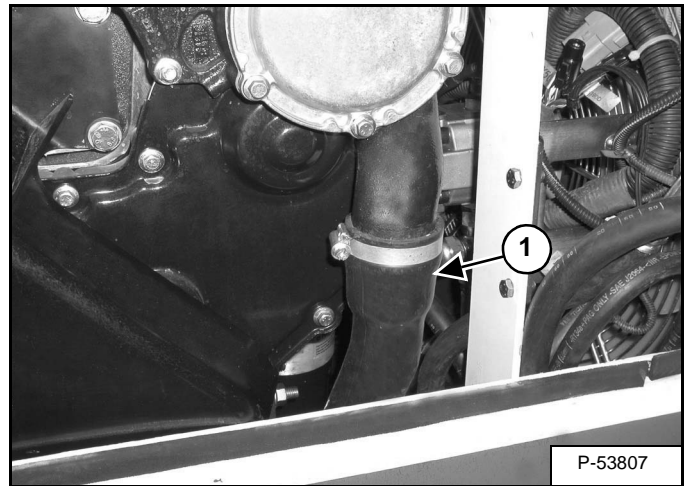

Remove the lower radiator hose (Item 1) [Figure 70-60-3] from the water pump.

ENGINE COMPONENTS AND TESTING (CONT'D)

Fuel Injection Pump Installation (Cont'd)

Figure 70-70-23

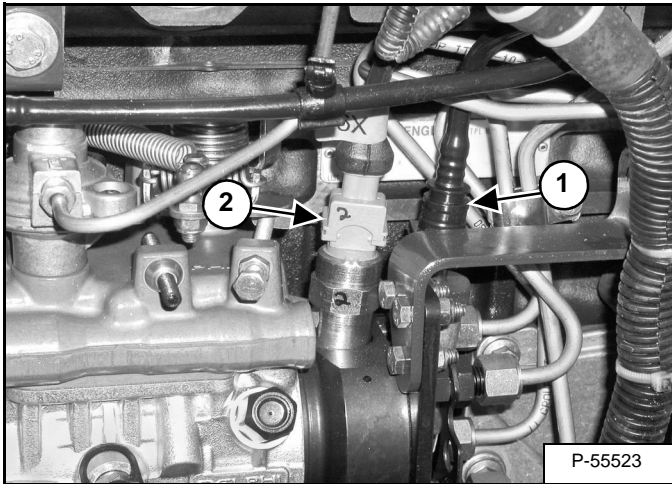

Install the two fuel lines (Item 1) [Figure 70-70-22] and [Figure 70-70-23].

Install the electrical connector (Item 2) [Figure 70-70-23].

Figure 70-70-24

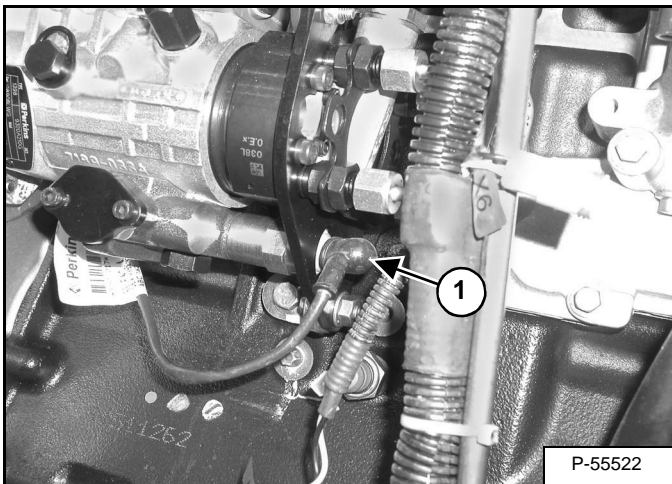

Install the harness (Item 1) [Figure 70-70-24].

Remove air from the system.

Fuel Injectors Removal And Installation

! WARNING

Diesel fuel or hydraulic fluid under pressure can penetrate skin or eyes, causing serious injury or death. Fluid leaks under pressure may not be visible. Use a piece of cardboard or wood to find leaks. Do not use your bare hand. Wear safety goggles. If fluid enters skin or eyes, get immediate medical attention from a physician familiar with this injury.

W-2072-0496

Figure 70-70-25

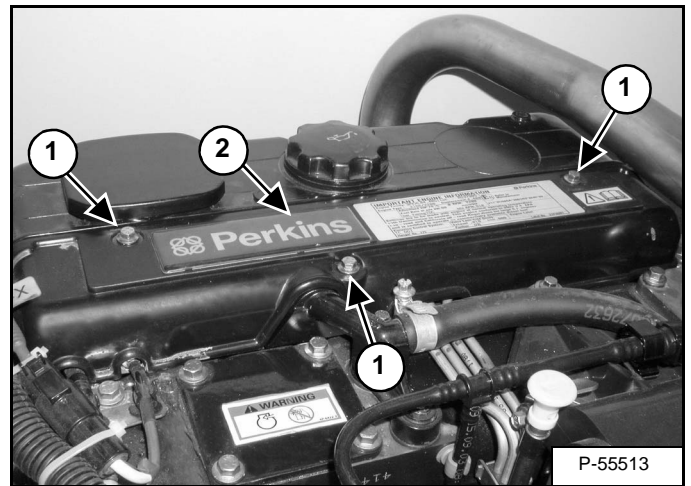

Remove the three bolts (Item 1) and remove the fuel injector cover (Item 2) [Figure 70-70-25].

Figure 70-70-26

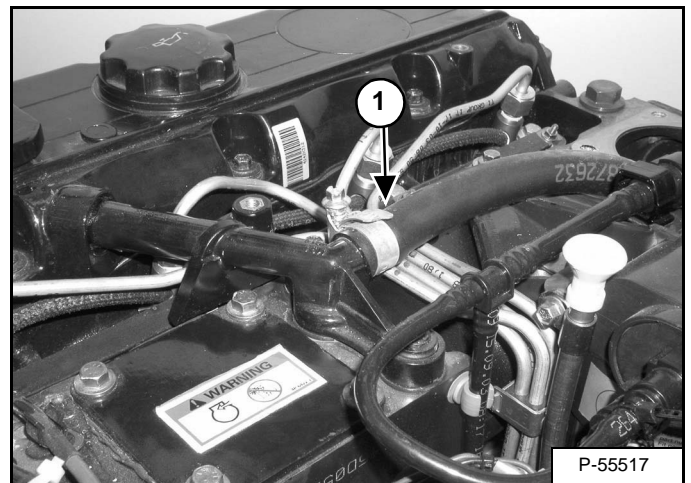

Remove the breather hose (Item 1) [Figure 70-70-26].

ENGINE/HYDROSTAT ASSEMBLY

Removal And Installation

Raise the boom and install the boom stop. (See page 10-150-1)

Remove the engine cover. (See page 50-70-1)

Remove the air intake cowling. (See page 50-71-1)

Drain the hydraulic reservoir. (See page 10-100-3)

Drain the radiator. (See page 70-50-1)

Remove the battery. (See page 60-20-1)

Remove the muffler. (See page 70-30-1)

Remove the drive shaft. (See page 40-70-1)

If equipped with air conditioning, remove the refrigerant from the A/C system. (See page 80-100-1)

Figure 70-80-1

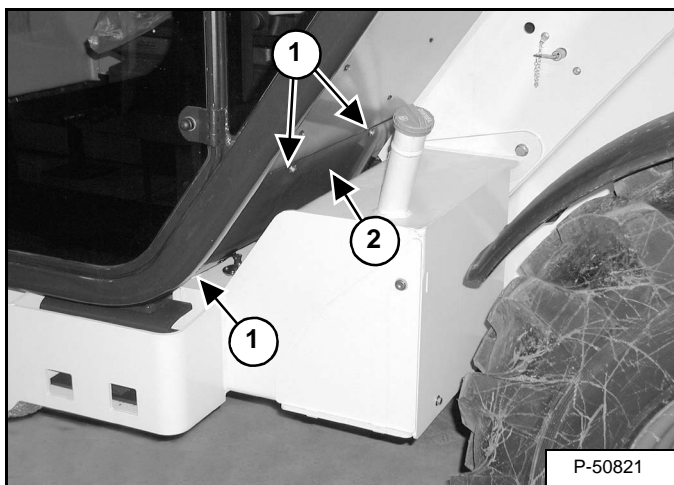

Remove the three screws (Item 1) from the access cover (Item 2) [Figure 70-80-1] located on the back of the cab.

Remove the access cover.

NOTE: Mark all hoses and electrical connectors, for correct installation.

Figure 70-80-2

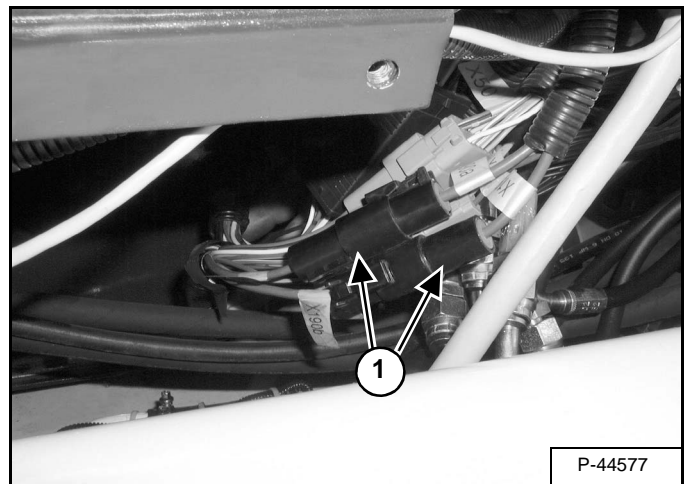

Unplug the two electrical connectors (Item 1) [Figure 70-80-2].

Figure 70-80-3

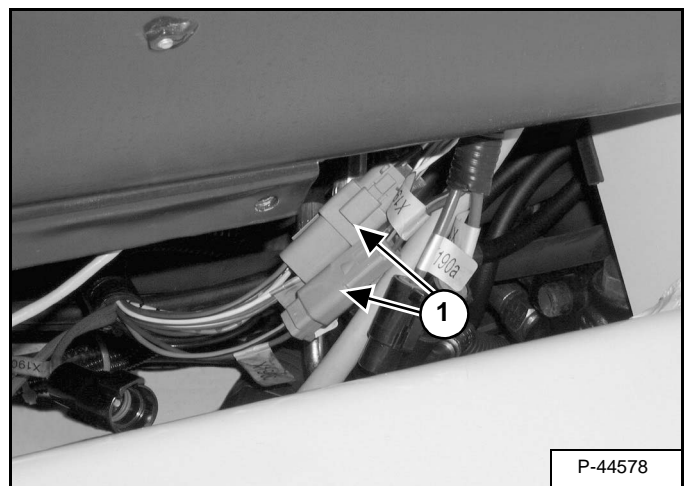

Unplug the two electrical connectors (Item 1) [Figure 70-80-3].

ENGINE/HYDROSTAT ASSEMBLY (CONT'D)

Removal And Installation (Cont'd)

Figure 70-80-39

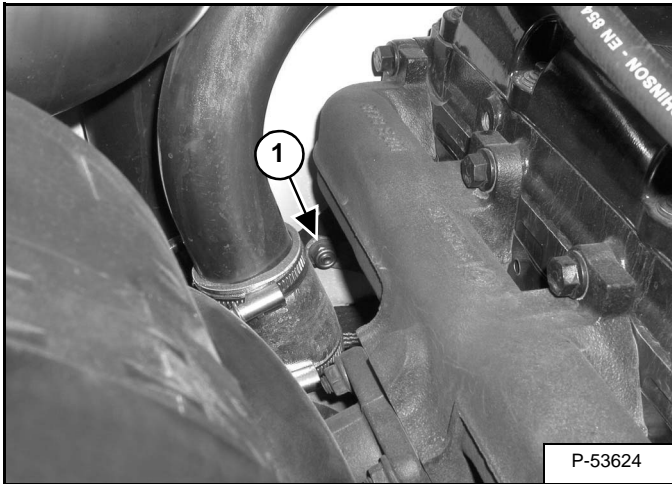

Route the ground strap mounting bolt (Item 1) [Figure 70-80-39].

Figure 70-80-40

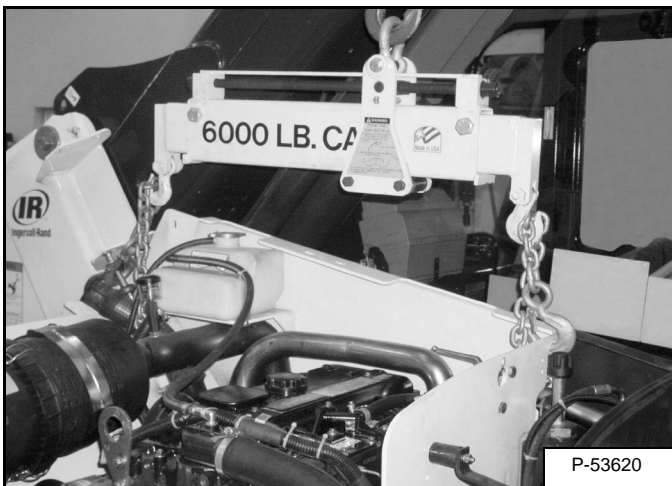

Install a chain hoist to lift and secure the engine assembly [Figure 70-80-40].

Figure 70-80-41

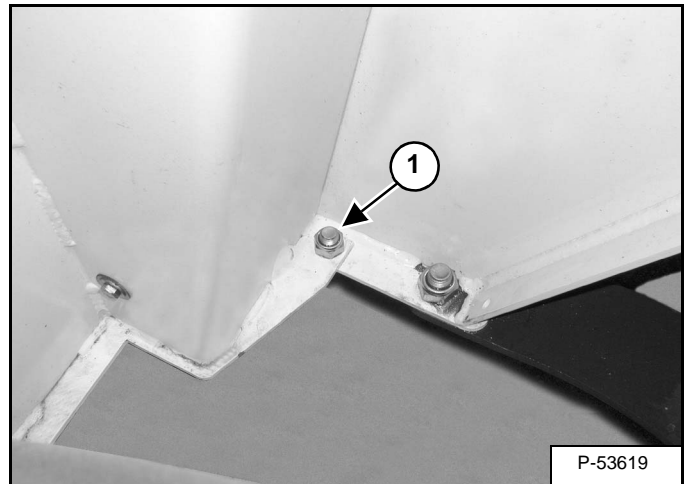

Remove the engine assembly mounting bolt (Item 1) [Figure 70-80-41] from the lower front.

RECONDITIONING THE ENGINE (CONT'D)

Rocker Cover Removal And Installation

Remove the fuel injector cover. (See page 70-100-4)

Figure 70-100-12

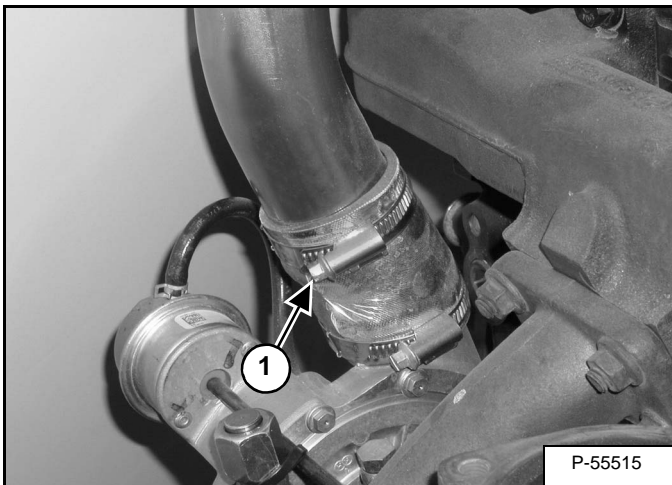

Loosen the intake tube clamp (Item 1) [Figure 70-100-12].

Figure 70-100-13

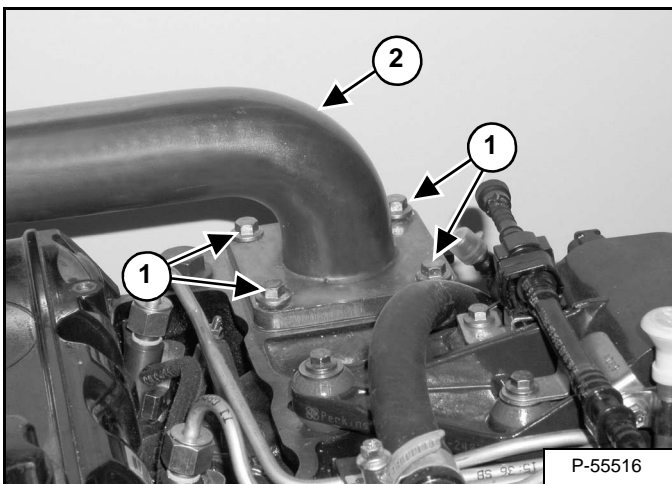

Remove the four bolts (Item 1) and remove the intake tube (Item 2) [Figure 70-100-13].

Figure 70-100-14

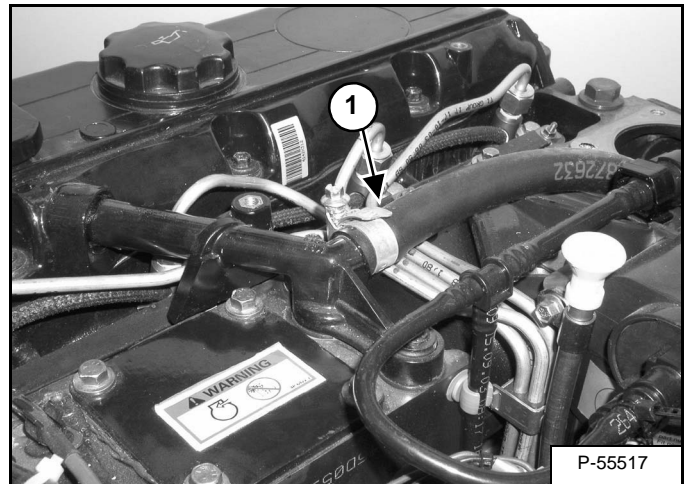

Remove the breather hose (Item 1) [Figure 70-100-14].

Figure 70-100-15

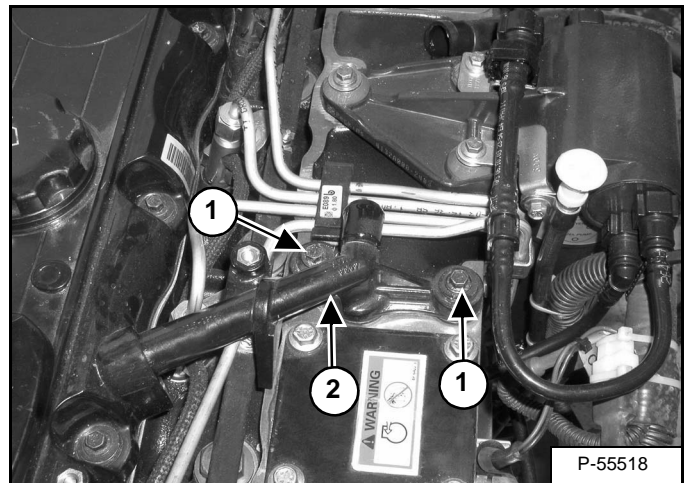

Remove the two bolts (Item 1) and remove the breather fitting (Item 2) [Figure 70-100-15].

RECONDITIONING THE ENGINE (CONT'D)

Valves Checking

NOTE: If the valves do not meet specifications they need to be replaced. They cannot be ground.

Figure 70-100-42

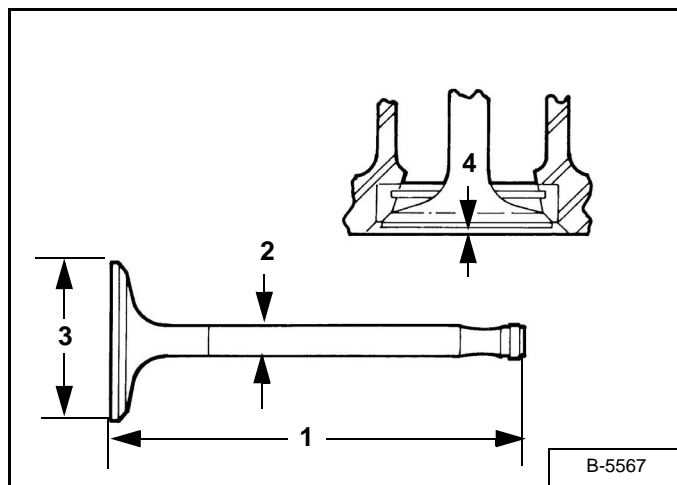

Use the following chart [Figure 70-100-42] to check the valve dimensions.

Ref.	Valve	Specifications
1.	Intake	5.076-5.093 inch (128,92-129,37 mm)
	Exhaust	5.075-5.093 inch (128,92-129,37 mm)
2.	Intake	0.3525-0.3533 inch (8,95-8,98 mm)
	Exhaust	0.3519-0.3528 inch (8,93-8,96 mm)
3.	Intake	1.819-1.829 inch (46,20-46,45 mm)
	Exhaust	1.634-1.644 inch (41,51-41,75 mm)
4.	Intake (Production)	0.062-0.072 inch (1,58-1,84 mm)
	Intake (Service Max.)	0.082 inch (2,09 mm)
	Exhaust (Production)	0.060-0.071 inch (5,53-1,81 mm)
	Exhaust (Service Max.)	0.081 inch (2,06 mm)
	Intake/Exhaust Valve Face Angle	30°

Cutting A Valve Seat

Before any work is done the valve guides must meet specifications or have been replaced.

Install the pilot in the valve guide.

Select the correct size cutter.

Valve Seat Angle	30°
------------------	-----

Figure 70-100-43

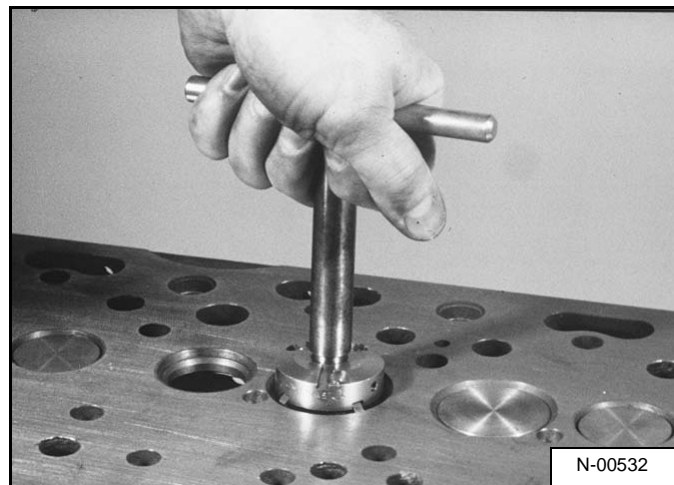

Carefully turn the cutter in a clockwise direction using even downward pressure. Keep the valve seat as narrow as possible [Figure 70-100-43].

Remove any cutting debris.

Install the valve and lightly tap.

Check the valve depth to make sure that it is within limits. (See page 70-100-12)

NOTE: If the valve seat is worn or damaged, a new valve seat insert can be installed.

RECONDITIONING THE ENGINE (CONT'D)

Camshaft And Tappets Installation (Cont'd)

Figure 70-100-71

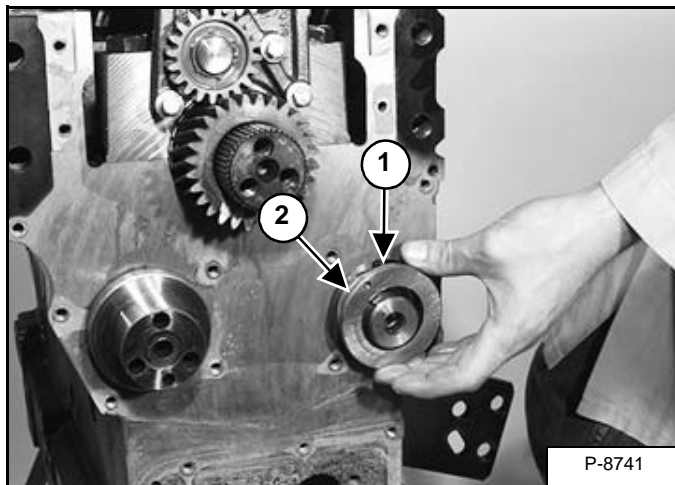

Install the camshaft thrust washer (Item 1). Make sure that the dowel pin (Item 2) **[Figure 70-100-71]** lines up with the hole in the thrust washer.

Install the timing case. (See page 70-100-21)

Check camshaft end play. The end play for a new engine is 0.004 - 0.022 inch (0,10 - 0,55 mm), service limits 0.023 inch (0,60 mm).

Install the timing gears. (See page 70-100-21)

Install the injection pump. (See page 70-70-4)

Install the push rods and rocker assembly. (See page 70-100-11.)

Install the timing cover. (See page 70-100-19)

Install the oil pan. (See page 70-100-43)

RECONDITIONING THE ENGINE (CONT'D)

Inspection Of Crankshaft And Bearings

Figure 70-100-97

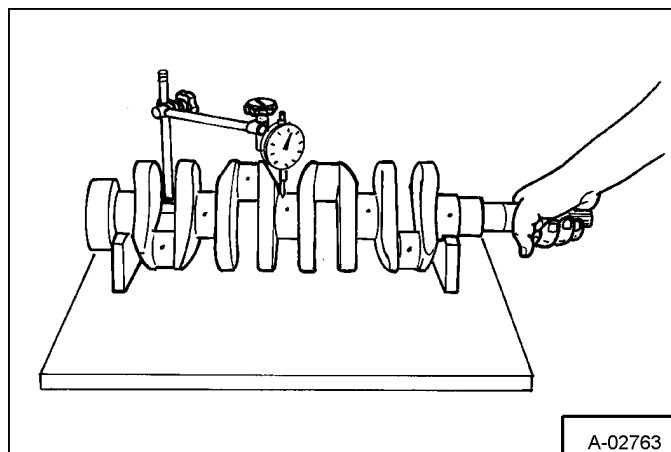

Check the crankshaft for wear [Figure 70-100-97]. The maximum wear and out of round of the crank journals is 0.0016 inch (0,04 mm).

The main journals and the crank pins of standard size can be machined 0.010 inch (0,25 mm) 0.020 inch (0,50 mm) or 0.030 inch (0,75 mm).

NOTE: See “ENGINE SPECIFICATIONS” on page SPEC-20-1 for more crankshaft specifications.

Check the oil clearance of the bearings.

All Main Bearings	0.0022 - 0.0046 inch (0,057 - 0,117 mm)
-------------------	---

Thrust Washer Thickness	
Standard	0.089 - 0.091 inch (2,26 - 2,31 mm)
Oversize	0.096 - 0.098 inch (2,45 - 2,50 mm)

Crankshaft And Bearings Installation

Figure 70-100-98

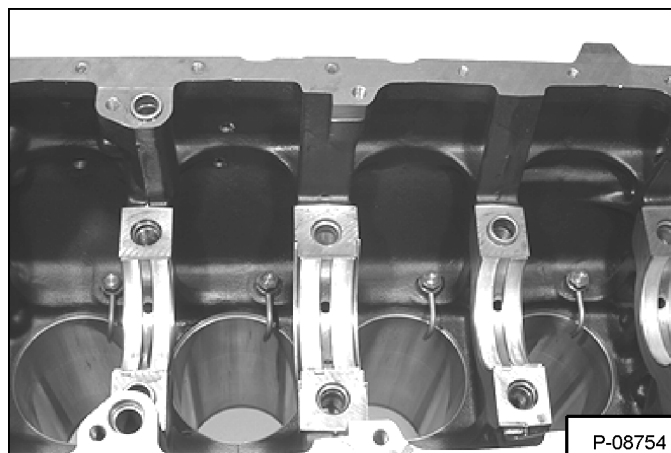

Clean the main bearing bores and install the upper bearing shells in position. Lubricate the bearings with clean engine oil [Figure 70-100-98].

NOTE: Only the upper half of the bearings has oil lubrication holes and must be installed in the cylinder block.

Figure 70-100-99

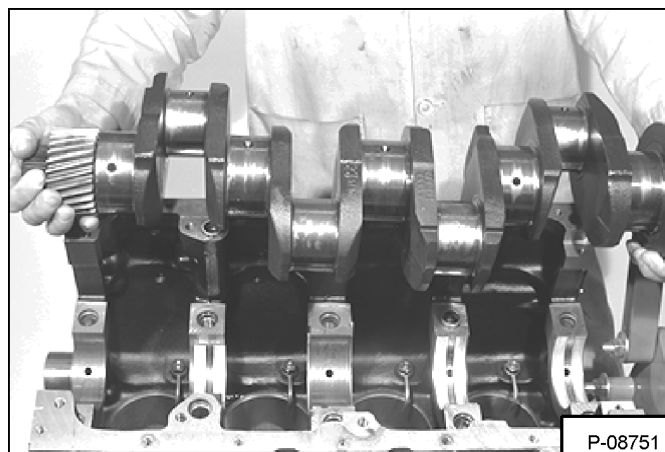

Make sure the main journals are clean and install the crankshaft in the block [Figure 70-100-99].

Make sure the locating pins for the main caps are in position.

RECONDITIONING THE ENGINE (CONT'D)

Oil Pump Installation

Figure 70-100-126

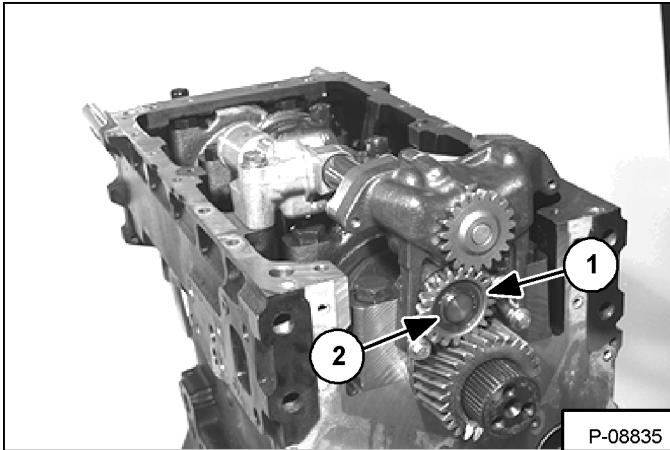

Fill the pump with engine oil.

If the number one main cap was removed, reinstall and tighten to 185 ft.-lbs. (250 Nm) torque.

Install the pump on the main cap and tighten to 16 ft.-lbs. (22 Nm) torque.

Check the idler gear and bushing for wear.

Lubricate with clean engine oil and install the washer, idler gear (Item 1) and snap ring (Item 2) [Figure 70-100-126].

Check the backlash between oil pump and idler gears.

There must be a minimum of 0.003 inch (0,076 mm).

Figure 70-100-127

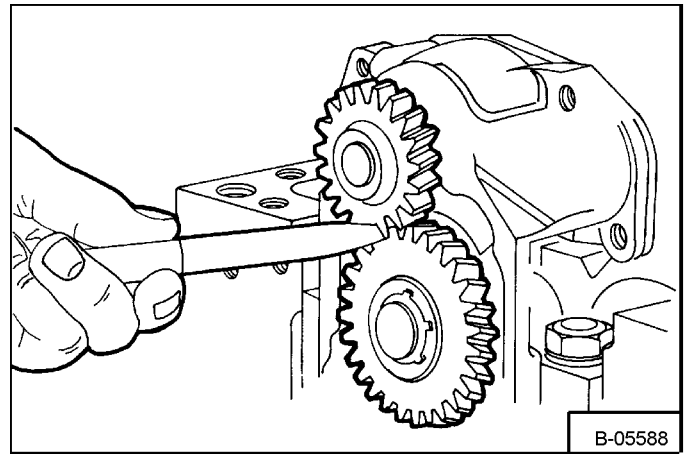

Check that there is a minimum of 0.003 inch (0,076 mm) backlash between the idler gear and oil pump gear [Figure 70-100-127].

End play for the idler gear should be 0.0019/0.0108 inch (0,050/0,275 mm).

Install the oil screen and pick-up tube. (See page 70-100-44.)

Install the pressure relief valve.

Install the oil pan. (See page 70-100-43.)



Bobcat®

BASIC TROUBLESHOOTING

Poor A/C Performance

Start the Telescopic Handler, engage the parking brake. Engage the A/C system with the blower fan on high. Run the Telescopic Handler at full RPM for approximately 15 minutes, with the cab door closed.

Figure 80-50-1

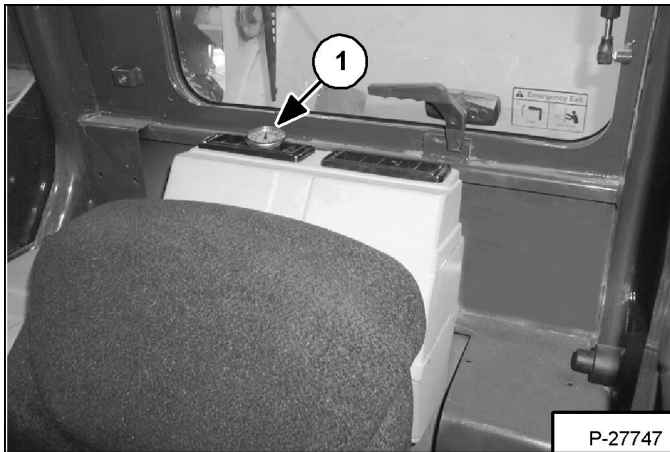
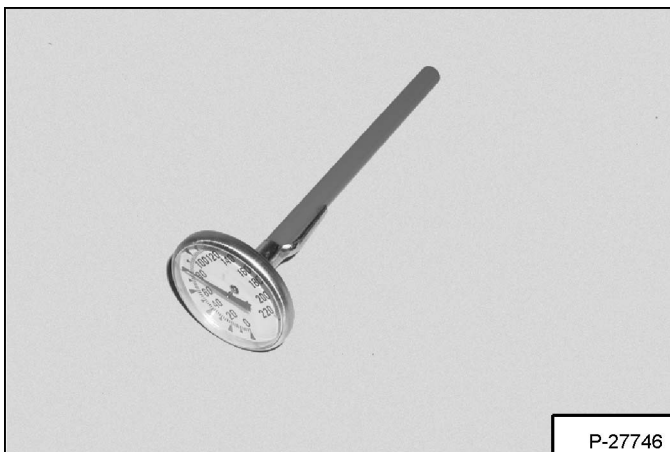

Figure 80-50-2



Check the temperature at the louvers (Item 1) [Figure 80-50-1] with a thermometer [Figure 80-50-2].

The louver temperature should be between 36-53° F (2.2-11,6° C) depending on the amount of humidity in the air.

If the louver temperature is too high. (See "SYSTEM TROUBLESHOOTING CHART" on page 80-70-1)

Check the blower fan for proper operation or noise, and replace if necessary. (See "EVAPORATOR/BLOWER UNIT" on page 80-150-1)

Check the belt tension on the A/C compressor. (See "Compressor Drive Belt Inspection" on page 80-40-2)

Check the A/C condenser for dirt or mud, and clean if necessary. (See "CONDENSER" on page 80-120-1)

Inspect the sight glass located on the receiver/drier for air bubbles. (See "RECEIVER/DRIER" on page 80-130-1)

Compressor Drive Belt Inspection

Regularly inspect (weekly) the compressor drive belt for wear.

Open the engine cover.

Remove the belt cover.

Figure 80-50-3

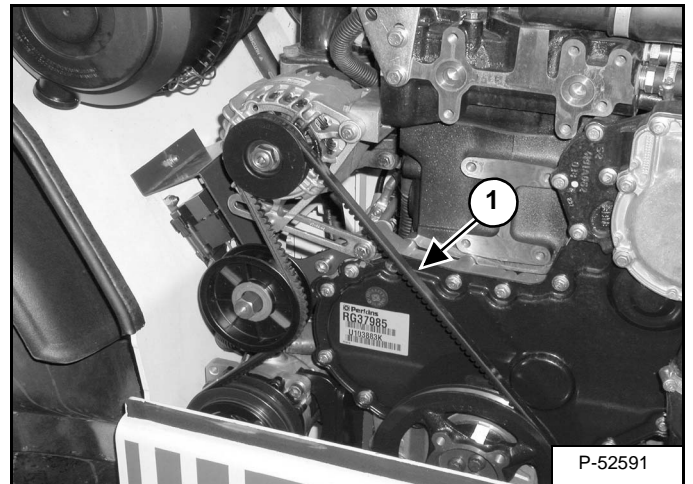

Check the tension on the compressor belt (Item 1) [Figure 80-50-3].

SYSTEM TROUBLESHOOTING CHART (CONT'D)

Gauge Pressure Related Troubleshooting (Cont'd)

POSSIBLE CAUSE	INSPECTION	SOLUTION
High pressure side Too low.		
1. Low refrigerant charge	The high side pressure will be low and bubbles may be present in sight glass on receiver drier.	Repair any leaks and recharge the refrigerant to the correct level.
System pressures Equal		
1. Clutch not operating	See magnetic clutch related topics above.	
2. Compressor not pumping.	Equal high and low pressures.	Replace compressor.

SYSTEM CHARGING AND RECLAMATION (CONT'D)

Charging Procedure With A Manifold Gauge Set (Cont'd)

Figure 80-100-12

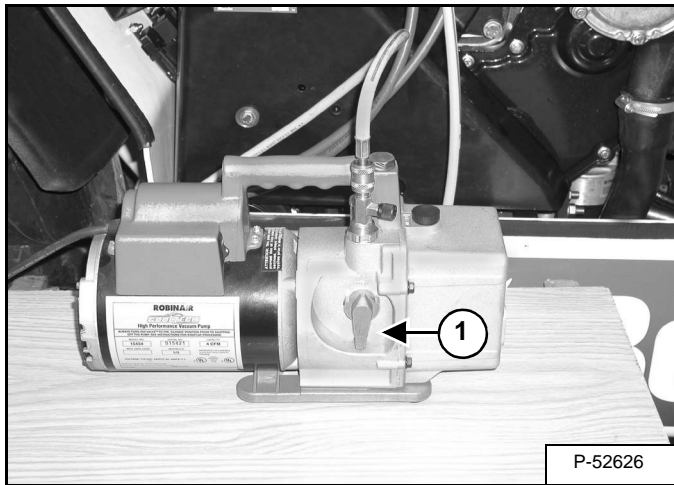

Start the vacuum pump and open ISO-valve (Item 1) [Figure 80-100-12] on the vacuum pump.

Run the vacuum pump for at least 5-10 minutes to insure that a vacuum has been pulled on the system.

Close the ISO-valve (Item 1) [Figure 80-100-12] (which isolates the vacuum pump from the A/C system) and turn OFF the vacuum pump.

Charging Procedure

Figure 80-100-13

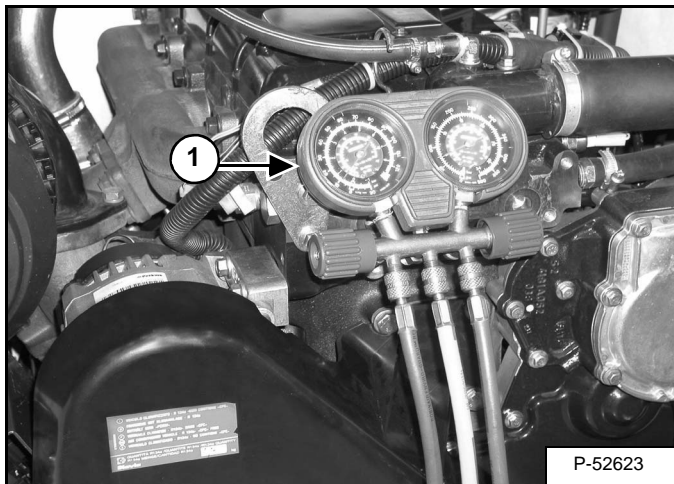

Note vacuum pressure indicated on the low pressure (Blue) gauge (Item 1) [Figure 80-100-13]. Let stand for 5-10 minutes and recheck the pressure for changes.

If the pressure drops, this may be an indication of a leak in the A/C system.

Determine the problem with the A/C system and repair it.

Figure 80-100-14

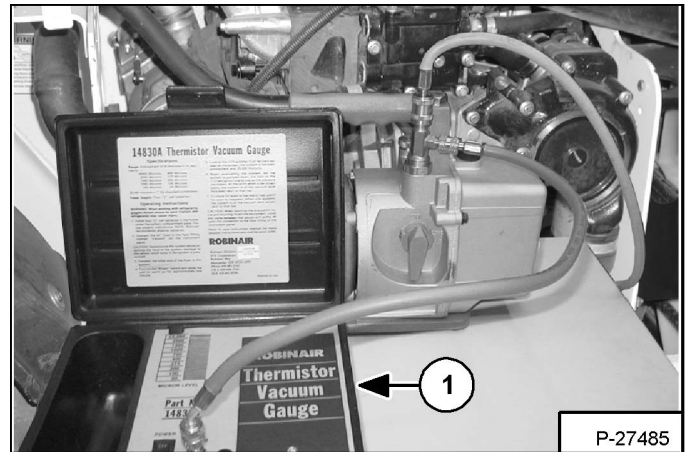

A thermistor vacuum gauge (Item 1) [Figure 80-100-14] can be used to determine the critical vacuum level during evacuation. It is a solid state instrument that constantly monitors and visually indicates the vacuum level.

The thermistor vacuum gauge is used with the vacuum pump [Figure 80-100-14].

Start the vacuum pump and open ISO-valve on the vacuum pump.

Be sure that both hand valves, and both charge port valves are open.

Run the vacuum pump for at least 45 minutes to insure that all the moisture is boiled out of the system.

Stop the vacuum pump and close the ISO-valve on the vacuum pump.

Close both hand valves on the manifold gauge set and remove the yellow hose from the vacuum pump that goes to the manifold gauge set.

Remove the vacuum pump and thermistor vacuum gauge.

RECEIVER/DRIER

Removal And Installation

Open the engine cover.

Remove the refrigerant from the A/C system. (See "Reclamation Procedure" on page 80-100-1)

Remove the air cleaner. (See "Housing Removal And Installation" on page 70-40-1)

Remove the two hoses (Item 1) [Figure 80-130-2] from the Receiver/Drier.

NOTE: Mark the hoses for correct installation.

NOTE: Install caps and plugs on all fittings.

Loosen the bolt (Item 2) [Figure 80-130-2] on the mounting bracket.

WARNING

In the event of a leakage, wear safety goggles. Escaping refrigerant can cause severe injuries to eyes. In contact with a flame, R134a refrigerant gives a toxic gas.

W-2371-0500

Figure 80-130-1

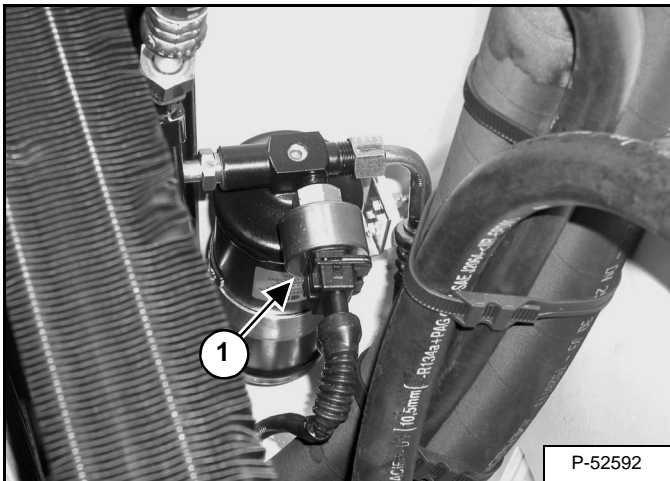

Unplug the connector (Item 1) [Figure 80-130-1] from the pressure switch.

Figure 80-130-2

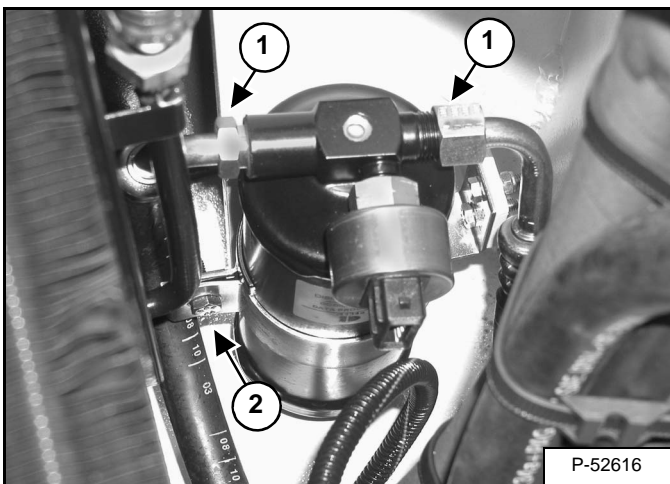

CLICK HERE TO **DOWNLOAD** THE COMPLETE MANUAL

- Thank you very much for reading the preview of the manual.
- You can download the complete manual from: www.heydownloads.com by clicking the link below



- Please note: If there is no response to CLICKING the link, please download this PDF first and then click on it.

CLICK HERE TO **DOWNLOAD** THE COMPLETE MANUAL