



Bobcat®

Service Manual

T300 Compact Track Loader

S/N A5GU20001 & Above
S/N A5GV20001 & Above

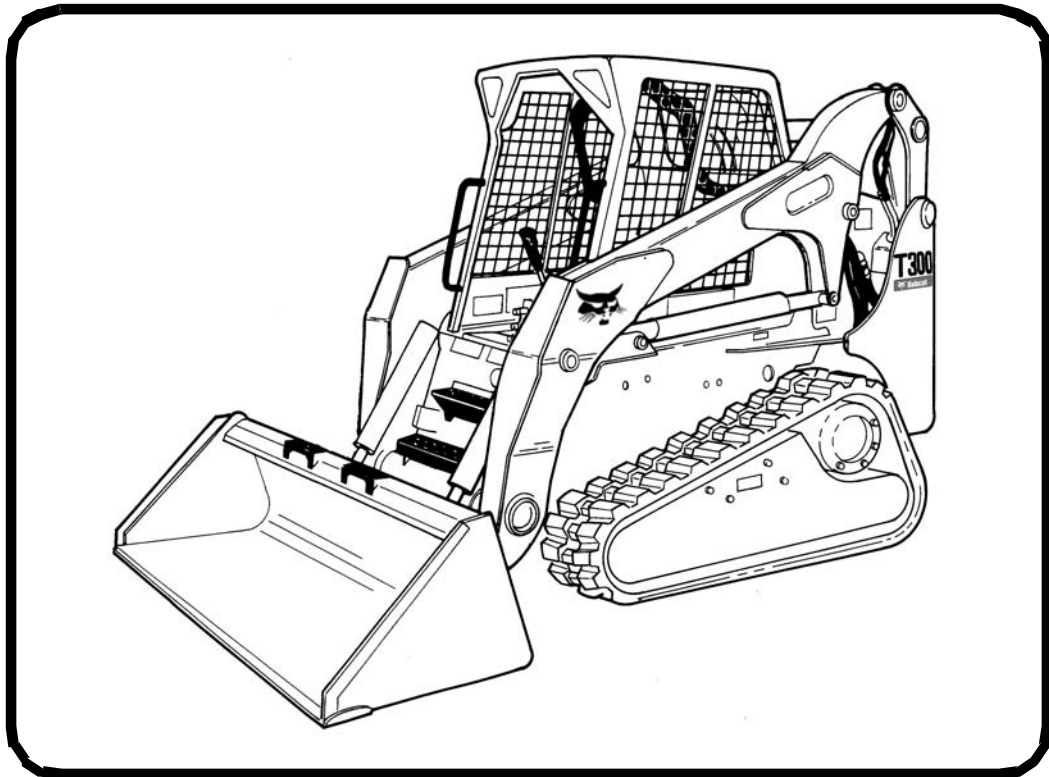

EQUIPPED WITH
BOBCAT INTERLOCK
CONTROL SYSTEM (BICS™)



CLICK HERE TO **DOWNLOAD** THE COMPLETE MANUAL

- Thank you very much for reading the preview of the manual.
- You can download the complete manual from: www.heydownloads.com by clicking the link below



- Please note: If there is no response to CLICKING the link, please download this PDF first and then click on it.

CLICK HERE TO **DOWNLOAD** THE COMPLETE MANUAL

SAFETY INSTRUCTIONS



Safety Alert Symbol

This symbol with a warning statement means: "Warning, be alert! Your safety is involved!" Carefully read the message that follows.



WARNING

Instructions are necessary before operating or servicing machine. Read and understand the Operation & Maintenance Manual, Operator's Handbook and signs (decals) on machine. Follow warnings and instructions in the manuals when making repairs, adjustments or servicing. Check for correct function after adjustments, repairs or service. Untrained operators and failure to follow instructions can cause injury or death.

W-2003-0903

IMPORTANT

This notice identifies procedures which must be followed to avoid damage to the machine.

I-2019-0284



DANGER

The signal word DANGER on the machine and in the manuals indicates a hazardous situation which, if not avoided, will result in death or serious injury.

D-1002-1107



WARNING

The signal word WARNING on the machine and in the manuals indicates a potentially hazardous situation which, if not avoided, could result in death or serious injury.

W-2044-1107

The following publications provide information on the safe use and maintenance of the Bobcat machine and attachments:

- The Delivery Report is used to assure that complete instructions have been given to the new owner and that the machine is in safe operating condition.
- The Operation & Maintenance Manual delivered with the machine or attachment contains operating information as well as routine maintenance and service procedures. It is a part of the machine and can be stored in a container provided on the machine. Replacement Operation & Maintenance Manuals can be ordered from your Bobcat dealer.
- Machine signs (decals) instruct on the safe operation and care of your Bobcat machine or attachment. The signs and their locations are shown in the Operation & Maintenance Manual. Replacement signs are available from your Bobcat dealer.
- An Operator's Handbook fastened to the operator cab. It's brief instructions are convenient to the operator. The handbook is available from your dealer in an English edition or one of many other languages. See your Bobcat dealer for more information on translated versions.
- The AEM Safety Manual delivered with the machine gives general safety information.
- The Service Manual and Parts Manual are available from your dealer for use by mechanics to do shop-type service and repair work.
- The Skid-Steer Loader Operator Training Course is available through your local dealer or at www.training.bobcat.com or www.bobcat.com. This course is intended to provide rules and practices of correct operation of the Skid-Steer Loader. The course is available in English and Spanish versions.
- Service Safety Training Courses are available from your Bobcat dealer or at www.training.bobcat.com or www.bobcat.com. They provide information for safe and correct service procedures.
- The Skid-Steer Loader Safety Video is available from your Bobcat dealer or at www.training.bobcat.com or www.bobcat.com.

SAFETY & MAINTENANCE (CONT'D)

SPARK ARRESTER MUFFLER	10-150-1
Cleaning Procedure	10-150-1
STOPPING THE ENGINE AND LEAVING THE LOADER	10-180-1
Procedure	10-180-1
TOWING THE LOADER	10-50-1
Procedure	10-50-1
TRANSPORTING LOADER ON A TRAILER	10-40-1
Fastening	10-40-1
Loading And Unloading	10-40-1

TIGHTEN ALL HARDWARE PER SIZE TO GRADE 5 TORQUE (SEE STANDARD TORQUE SPECIFICATIONS FOR BOLTS, SECTION SPEC-01) UNLESS OTHERWISE SPECIFIED.

SPECIFICATIONS SUBJECT TO CHANGE WITHOUT NOTICE AND STANDARD ITEMS MAY VARY.

OPERATOR CAB (CONT'D)

Forestry Door And Window Kit

Figure 10-30-9

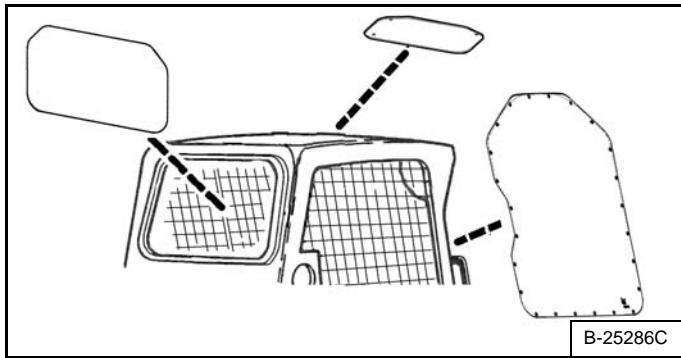

Must be used with Forestry Applications Kit to prevent flying debris and objects from entering the loader. Kit includes 19,05 (0.75 in) thick laminated polycarbonate front door, top and rear windows [Figure 10-30-9].

Forestry Door And Window Kit Inspection And Maintenance

- Inspect for cracks or damage. Replace if required.
- Order P/N 7140090 if door is damaged and needs to be replaced.
- Pre-rinse with water to remove gritty materials.
- Wash with a mild household detergent and warm water.
- Use a sponge or soft cloth. Rinse well with water and dry with a clean soft cloth or rubber squeegee.
- Do not use abrasive or highly alkaline cleaners.
- Do not clean with metal blades or scrapers.

Forestry Door Emergency Exit

Figure 10-30-10

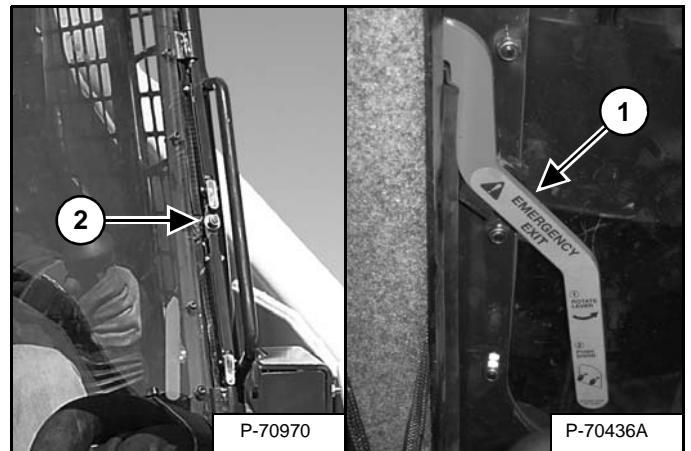

- Inspect the emergency exit lever (Item 1), linkages and hardware (Item 2) [Figure 10-30-10] for loose or damaged parts.
- Repair or replace if necessary.

REMOTE START TOOL KIT-MEL1563 (CONT'D)

Remote Start Procedure (Cont'd)

Figure 10-60-12

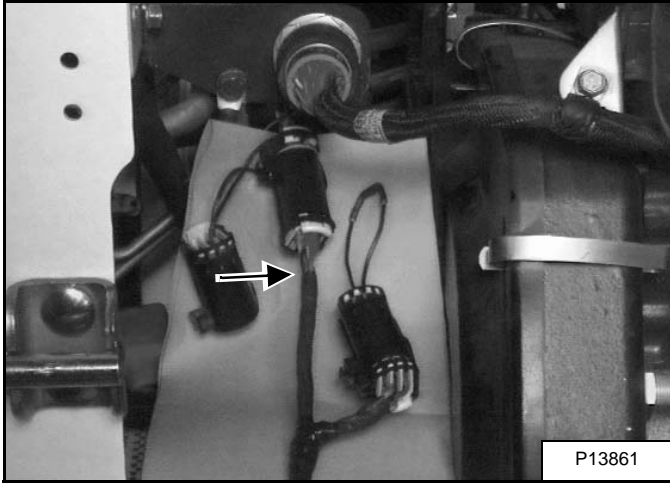

Connect the remote start tool to the engine harness connector [Figure 10-60-12].

NOTE: The key switch on the right-hand side operator panel must be in the off position or the Remote Start Kit will not operate.

WARNING

UNAUTHORIZED AND UNEXPECTED ENGINE STARTUP CAN CAUSE SERIOUS INJURY OR DEATH

With the 7-pin connector plugged into the machine and Remote Start Tool Key Switch in the OFF position, the engine can be started from the operator panel inside the cab.

- Place the key switch of the Remote Start Tool in the RUN position to disconnect the operator panel from the start circuit.
- Remove the operator panel key (key switch), lock the keypad with a unique password (keyless) or otherwise disable the starter before working in the engine area.

W-2457-1110

SERVICE SCHEDULE

Chart

Maintenance work must be done at regular intervals. Failure to do so will result in excessive wear and early failures. The service schedule is a guide for correct maintenance of the Bobcat loader.

 <b style="font-size: 24pt; margin-left: 10px;">WARNING	<p>Instructions are necessary before operating or servicing machine. Read and understand the Operation & Maintenance Manual, Operator's Handbook and signs (decals) on machine. Follow warnings and instructions in the manuals when making repairs, adjustments or servicing. Check for correct function after adjustments, repairs or service. Untrained operators and failure to follow instructions can cause injury or death.</p> <p style="text-align: right; font-size: 10pt;">W-2003-0903</p>
--	--

SERVICE SCHEDULE		HOURS					
ITEM	SERVICE REQUIRED	8-10	50	100	■ 250	■ 500	■ 1000
Engine Oil	Check the oil level and add as needed. Do not overfill.						
Engine Air Filter and Air System	Check display panel. Service only when required. Check for leaks and damaged components.						
Engine Cooling System	Clean debris from oil cooler, radiator and grille. Check coolant level COLD and add premixed coolant as needed.						
Fuel Filter	Remove the trapped water.						
Lift Arms, Cylinders, Bob-Tach Pivot Pins and Wedges	Lubricate with multi-purpose lithium based grease.						
Seat Bar, Control Interlocks, Seat Belt, Seat Belt Retractors	Check the condition of seat belt. Clean or replace seat belt retractors as needed. Check the seat bar and control interlocks for correct operation. Clean dirt and debris from moving parts.						
Bobcat Interlock Control Systems (BICS™)	Check for correct function. Lift and Tilt functions MUST NOT operate with seat bar raised. See details in this Manual.						
Front Horn / Back-up Alarm	Check for proper function.						
Safety Signs and Safety Treads	Check for damaged signs (decals) and safety treads. Replace any signs or safety treads that are damaged or worn.						
Operator Cab	Check the fastening bolts, washers and nuts. Check the condition of the cab.						
Indicators and Lights	Check for correct operation of all indicators and lights.						
Heater and A/C Filters (If Equipped)	Clean or replace filters as needed.						
Hydraulic Fluid, Hoses and Tubelines	Check fluid level and add as needed. Check for damage and leaks. Repair or replace as needed.						
Tracks	Check for damaged or worn tracks and correct tension.	□					
Track Sprocket Nuts	Check torque. Tighten as needed. See procedure in this manual.						
Parking Brake, Foot Pedals, Hand Controls and Steering Levers or Joysticks	Check for correct operation. Repair or adjust as needed.						
Spark Arrester Muffler	Clean the spark chamber.						
Battery	Check cables, connections and electrolyte level. Add distilled water as needed.						
Steering Lever Pivots	Grease fittings.						
Fuel Filter	Replace filter element.						
Engine / Hydro. Drive Belt	Check for wear or damage. Check idler arm stop.		▲				
Drive Belts (Alternator, air conditioning, water pump)	Check condition and tension. Adjust or replace as needed.						
Bobcat Interlock Control System (BICS™)	Check the function of the lift arm bypass control.						
Engine Oil and Filter	Replace oil and filter.		▲	*			
Hydraulic / Hydrostatic Filter, Charge Filter, Reservoir Breather	Replace the hydraulic / hydrostatic filter, charge filter, and the reservoir breather.		●				
Hydrostatic Drive Motor	Replace oil with high performance synthetic oil P/N 7003026.						
Hydraulic Reservoir	Replace the fluid.						
Case Drain Filters	Replace the filters.		▲				
Engine Valves	Adjust the engine valves.						○
Coolant	Replace the coolant	Every 2 years					

- Or every 12 months.
- ▲ Perform at first 50 hours, then as scheduled.
- Check every 8 - 10 hours for the first 24 hours, then at 50 hour intervals.
- Replace the hydraulic / hydrostatic filter element after the first 50 hours, then when service code [M0217] is displayed or as scheduled.
- * Change oil and filter every 100 hours when operating under severe conditions.
- Perform at first 500 hours, then as scheduled.

FUEL SYSTEM (CONT'D)

Removing Air From The Fuel System

After replacing the filter element or when the fuel tank has run out of fuel, the air must be removed from the fuel system before starting the engine.

WARNING

AVOID INJURY OR DEATH

Diesel fuel or hydraulic fluid under pressure can penetrate skin or eyes, causing serious injury or death. Fluid leaks under pressure may not be visible. Use a piece of cardboard or wood to find leaks. Do not use your bare hand. Wear safety goggles. If fluid enters skin or eyes, get immediate medical attention from a physician familiar with this injury.

W-2072-0807

Figure 10-100-4

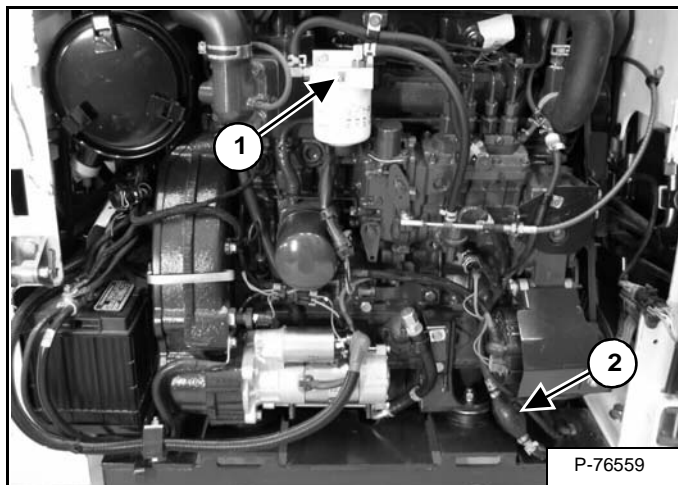

Open the vent (Item 1) [Figure 10-100-4] on the fuel filter housing.

Squeeze the hand pump (priming bulb) (Item 2) [Figure 10-100-4] until fuel flows from the vent with no air bubbles.

Close the vent (Item 1) [Figure 10-100-4].

BOB-TACH (HAND LEVER)

Inspection And Maintenance

Figure 10-130-1

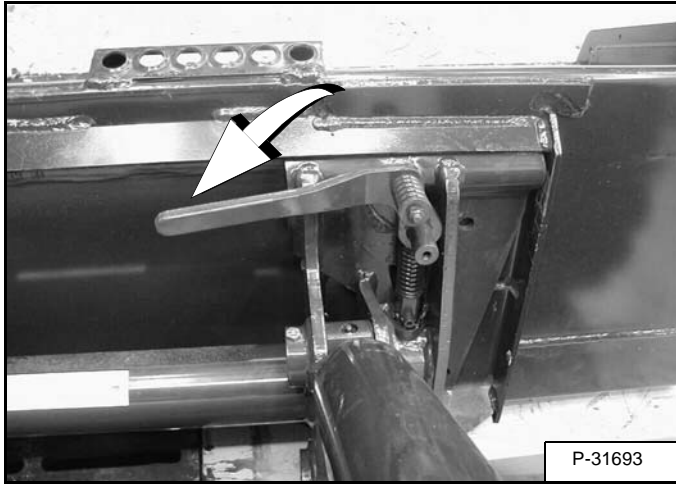

Move the Bob-Tach levers down to engage the wedges [Figure 10-130-1].

The levers and wedges must move freely.

WARNING

AVOID INJURY OR DEATH

The Bob-Tach wedges must extend through the holes in the attachment mounting frame. Levers must be fully down and locked. Failure to secure wedges can allow attachment to come off.

W-2715-0208

Figure 10-130-2

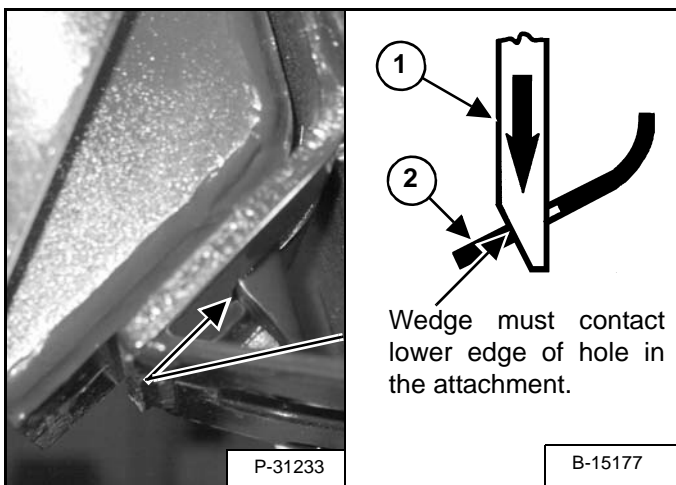

The wedges (Item 1) [Figure 10-130-2] must extend through the holes in the attachment mounting frame.

The spring loaded wedge (Item 1) must contact the lower edge of the hole in the attachment (Item 2) [Figure 10-130-2].

If the wedges do not contact the lower edge of the holes [Figure 10-130-2], the attachment will be loose and can come off the Bob-Tach.

Figure 10-130-3

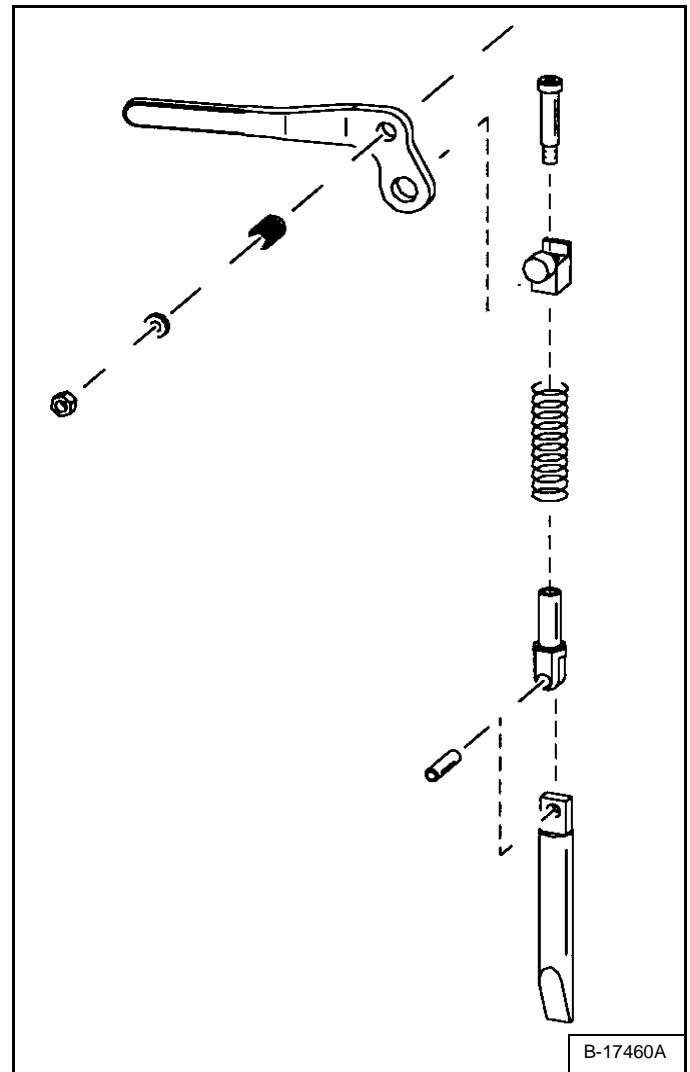

Inspect the mounting frame on the attachment and Bob-Tach, linkages and wedges for excessive wear or damage [Figure 10-130-3]. Replace any parts that are damaged, bent or missing. Keep all fasteners tight.

Look for cracked welds. Contact your Bobcat dealer for repair or replacement parts.

Lubricate the wedges. (See SERVICE SCHEDULE on Page 10-70-1) (See LUBRICATING THE LOADER on Page 10-140-1.)

LOADER STORAGE AND RETURN TO SERVICE

Storage

Sometimes it may be necessary to store your Bobcat Loader for an extend period of time. Below is a list of items to perform before storage.

- Thoroughly clean the loader including the engine compartment.
- Lubricate the loader.
- Replace worn or damaged parts.
- Park the loader in a dry protected shelter.
- Lower the lift arms all the way and put the bucket flat on the ground.
- Put blocks under the frame to remove weight from the tires.
- Put grease on any exposed cylinder rods.
- Put fuel stabilizer in the fuel tank and run the engine a few minutes to circulate the stabilizer to the pump and fuel injectors.
- Drain and flush the cooling system. Refill with premixed coolant.
- Replace all fluids and filters (engine, hyd. / hydro.).
- Replace air cleaner, heater and air conditioning filters.
- Put all controls in neutral position.
- Remove the battery. Be sure the electrolyte level is correct then charge the battery. Store it in a cool dry place above freezing temperatures and charge it periodically during storage.
- Cover the exhaust pipe opening.
- Tag the machine to indicate that it is in storage condition.

Return To Service

After the Bobcat Loader has been in storage, it is necessary to follow a list of items to return the loader to service.

- Check the engine and hydraulic oil levels; check coolant level.
- Install a fully charged battery.
- Remove grease from exposed cylinder rods.
- Check all belt tensions.
- Be sure all shields and guards are in place.
- Lubricate the loader.
- Check tire inflation and remove blocks from under frame.
- Remove cover from exhaust pipe opening.
- Start the engine and let run for a few minutes while observing the instrument panels and systems for correct operation.
- Operate machine, check for correct function.
- Stop the engine and check for leaks. Repair as needed.

HYDRAULIC SYSTEM (CONT'D)

HYDRAULIC CONTROL VALVE (STANDARD)	20-40-1
Anti-Cavitation Valve Removal And Installation (Lift, Rod End) .	20-40-8
Auxiliary Solenoid Removal And Installation (S/N A5GU34999 & Below And A5GV34999 & Below)	20-40-29
Auxiliary Spool Removal And Installation	20-40-27
Check Valve Removal And Installation	20-40-35
Description	20-40-1
End Cap Block Removal And Installation	20-40-14
Identification Chart	20-40-6
Lift Arm Bypass Orifice Removal And Installation	20-32-34
Lift Load Check Valve Removal And Installation	20-40-7
Lift Spool And Detent Removal And Installation	20-40-15
Load Check Valve Removal And Installation (Tilt And Auxiliary)	20-40-8
Lock Valve Removal And Installation	20-40-32
Main Relief Valve Removal And Installation	20-40-34
Mount Bracket Removal And Installation	20-40-7
Plug Removal And Installation	20-40-12
Port Relief / Anti-Cavitation Valve Removal And Installation (Lift, Base End)	20-40-9
Port Relief / Anti-Cavitation Valve Removal And Installation (Tilt, Base End)	20-40-10
Port Relief / Anti-Cavitation Valve Removal And Installation (Tilt, Rod End)	20-40-10
Port Relief Valve Removal And Installation	20-40-11
Removal And Installation	20-40-2
Rubber Boot Removal And Installation	20-40-13
Solenoid Removal And Installation	20-40-31
Tilt Spool Removal And Installation	20-40-25
HYDRAULIC FLUID RESERVOIR	20-90-1
Description	20-90-1
Hydraulic Fluid Screen	20-90-4
Removal And Installation	20-90-1
HYDRAULIC / HYDROSTATIC FILTERS	20-80-1
Description	20-80-1
Housing Removal And Installation	20-80-1

Continued On Next Page

HYDRAULIC/HYDROSTATIC SCHEMATIC WITH SJC AND HIGH FLOW OPTION T300 (S/N A5GU20001 AND ABOVE) (S/N A5GV20001 AND ABOVE)

(PRINTED MARCH 2008)
V-1187legend

LEGEND

- | | | | |
|--|---|---|---|
| <p>① RESERVOIR:
Capacity 18.8 qt. (17,8 L)</p> <p>② SPRING LOADED FILTER BY-PASS VALVE: 45-55 PSI (3,1-3,8 bar)</p> <p>③ DIFFERENTIAL PRESSURE SWITCH:
36-44 PSI (2,5-3,0 bar)
Normally Closed</p> <p>④ DRIVE MOTOR SHUTTLE VALVE</p> <p>⑤ RELIEF/REPLENISHING VALVE - HIGH PRESSURE: 5075 PSI (350 bar)</p> <p>⑥ RELIEF VALVE - CHARGE INLET:
360 PSI (24,8 bar)
at High Engine Idle
With 140 degrees F. (60 degrees C.) Fluid</p> <p>⑦ FRONT AUXILIARY MANUAL PRESSURE BLEED-OFF VALVE</p> <p>⑧ HYDRAULIC PUMP Gear Type
21.2 GPM (80,2 L/min.) at High Engine Idle</p> <p>⑨ RELIEF VALVE - MAIN:
3250-3350 PSI (224-231 bar)
at Front Quick Couplers</p> <p>⑩ PORT RELIEF/ANTICAVITATION VALVE
4000 PSI (276 bar)</p> <p>⑪ ANTICAVITATION VALVE</p> <p>⑫ SOLENOID ACTIVATED DIRECTIONAL CONTROL VALVE - AUXILIARY</p> <p>⑬ PORT RELIEF/ANTICAVITATION VALVE:
. (Optional)
3500 PSI (241,3 bar)</p> <p>⑭ LOAD CHECK VALVE</p> <p>⑮ LIFT CYLINDER SPOOL - MADE TO RESTRICT FLOW DURING BOOM DOWN BUT NOT DURING BOOM UP</p> | <p>⑯ SOLENOID ACTIVATED DIRECTIONAL CONTROL VALVE - BICS CONTROL</p> <p>⑰ PILOTED ACTIVATED DIRECTIONAL CONTROL VALVE - TILT CONTROL</p> <p>⑱ PILOTED ACTIVATED DIRECTIONAL CONTROL VALVE - LIFT CONTROL</p> <p>⑲ PULL BUTTON ACTIVATED DIRECTIONAL CONTROL VALVE - LIFT ARM BY-PASS</p> <p>⑳ PILOTED ACTIVATED DIRECTIONAL CONTROL VALVE - UNLOADING SPOOL</p> <p>㉑ PILOTED ACTIVATED DIRECTIONAL CONTROL VALVE - FLOW CONTROL SPOOL</p> <p>㉒ FLOW DIVIDER ADJUSTMENT VALVE</p> <p>㉓ SOLENOID ACTIVATED DIRECTIONAL CONTROL VALVE - BASE</p> <p>㉔ SOLENOID ACTIVATED DIRECTIONAL CONTROL VALVE - ROD</p> <p>㉕ LOAD SHUTTLE VALVE - BLEED OFF</p> <p>㉖ SOLENOID ACTIVATED DIRECTIONAL CONTROL VALVE - TWO COIL</p> <p>㉗ PILOT ACTIVATED DIRECTIONAL CONTROL VALVE - REAR AUXILIARY</p> <p>㉘ RESTRICTOR - 0.031 inch (0,8 mm)</p> <p>㉙ RELIEF VALVE: 3300 PSI (228 bar)</p> <p>㉚ HYDRAULIC BRAKE - SPRING APPLIED - PRESSURE RELEASE</p> <p>㉛ FILTER - HYDRAULIC (CANISTER)</p> <p>㉜ FILTER - CASE DRAIN (SINTERED BRONZE)</p> | <p>㉝ FILTER - BICS CONTROL VALVE (SCREEN)</p> <p>㉞ CHECK VALVE - BUCKET POSITION VALVE</p> <p>㉟ RESTRICTION</p> <p>㊱ VARIABLE CAPACITY DISPLACEMENT BI-DIRECTIONAL HYDROSTATIC PUMP</p> <p>㊲ SHUTTLE RELIEF VALVE
(Not Adjustable - Factory Set)
65 PSI (4,5 bar)</p> <p>㊳ FIXED CAPACITY DISPLACEMENT BI-DIRECTIONAL HYDROSTATIC MOTOR</p> <p>㊴ CHECK VALVE - With 80 PSI (5,5 bar) Spring</p> <p>㊵ SOLENOID ACTIVATED DIRECTIONAL CONTROL VALVE - BUCKET POSITION VALVE (ON/OFF)</p> <p>㊶ CHECK VALVE - BICS CONTROL VALVE</p> <p>㊷ RESTRICTION - 0.343 inch (8,7 mm)</p> <p>㊸ FILTER - Bob-Tach Valve</p> <p>㊹ PILOT ACTIVATED DIRECTIONAL CONTROL VALVE - HYDRAULIC POWERED BOB-TACH</p> <p>㊺ RESTRICTION - 0.089 inch (2,26 mm)</p> <p>㊻ RESTRICTION - 0.025 inch (0,6 mm)</p> <p>㊼ RELIEF VALVE - 2000 PSI (137 bar)</p> <p>㊽ RELIEF VALVE - 1200 PSI (83 bar)</p> <p>㊾ SOLENOID ACTIVATED DIRECTIONAL CONTROL VALVE (TWO COIL)</p> | <p>㊿ RELIEF VALVE - 3300 PSI (228 bar)</p> <p>51 DUMP VALVE - (ON/OFF)</p> <p>52 CHECK VALVE</p> <p>53 AUXILIARY HYDRAULIC PUMP - 15.8 GPM (59,9 L/min) at High Engine Idle</p> <p>54 CHECK VALVE - With 300 PSI (20,7 bar) Spring with 0.016 inch (0,40 mm) orifice</p> <p>55 SOLENOID ACTIVATED CONTROL VALVE - FORWARD/REVERSE</p> <p>56 SERVO PISTON -Swash Plate</p> <p>57 POSITION SENSOR -Swash Plate</p> <p>58 CHARGE PRESSURE SENSOR</p> <p>59 CHARGE PUMP - 14.2 GPM (53,7 L/min) at High Engine Idle</p> <p>60 FIXED CAPACITY DISPLACEMENT HYDRAULIC MOTOR</p> <p>61 ANTICAVITATION VALVE</p> <p>62 PROPORTIONAL RELIEF VALVE – (Fan Speed Regulator):
1566 - 1784 PSI (108 - 123 bar)</p> <p>63 CHECK VALVE</p> <p>64 SOLENOID ACTIVATED DIRECTIONAL CONTROL VALVE - BRAKE</p> <p>65 FILTER - HYDRAULIC</p> <p>66 SPRING LOADED FILTER BY-PASS VALVE: 75-83 PSI (5,2-5,7 bar)</p> |
|--|---|---|---|

NOTE: Unless otherwise specified, springs have NO significant pressure value.

CYLINDER (LIFT) (CONT'D)

Removal And Installation (Cont'd)

Figure 20-20-7

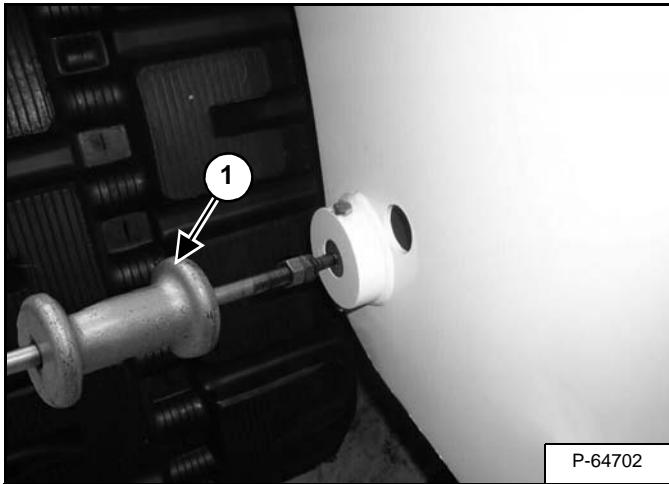

Install a slide hammer (Item 1) [Figure 20-20-7] and remove the base end pivot pin.

Remove the lift cylinder.

WARNING

AVOID INJURY OR DEATH

Always clean up spilled fuel or oil. Keep heat, flames, sparks or lighted tobacco away from fuel and oil. Failure to use care around combustibles can cause explosion or fire.

W-2103-0508

CYLINDER (TILT) (CONT'D)

Removal And Installation (Cont'd)

Figure 20-21-7

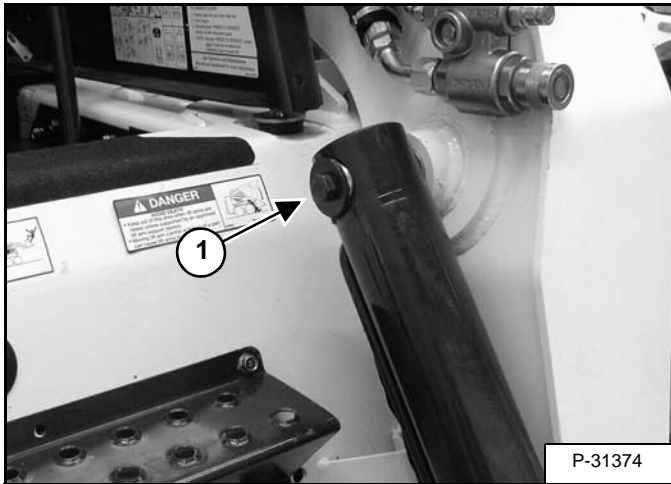

Remove the base end pivot bolt and washer (Item 1) [Figure 20-21-7].

Figure 20-21-8

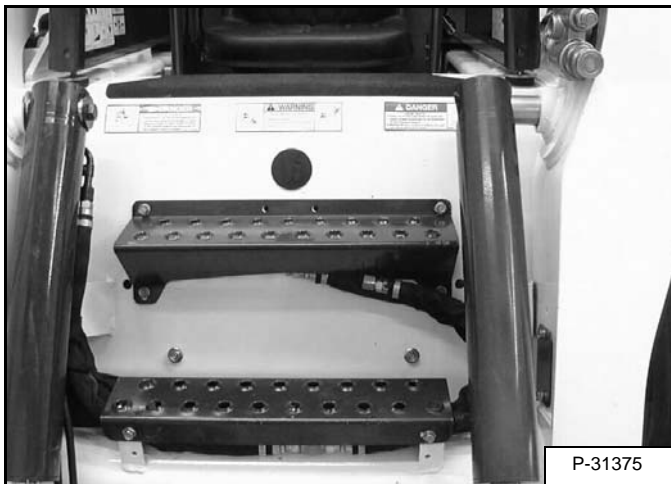

Slide the cylinder from the base pin and remove the tilt cylinder from the loader [Figure 20-21-8].

CYLINDER (BOB-TACH) (CONT'D)

Parts Identification

- | | |
|-------------|-----------|
| 1. Cylinder | 8. Ring |
| 2. Nut | 9. O-ring |
| 3. Piston | 10. Head |
| 4. O-ring | 11. Seal |
| 5. Ring | 12. Seal |
| 6. Spacer | 13. Rod |
| 7. O-ring | |

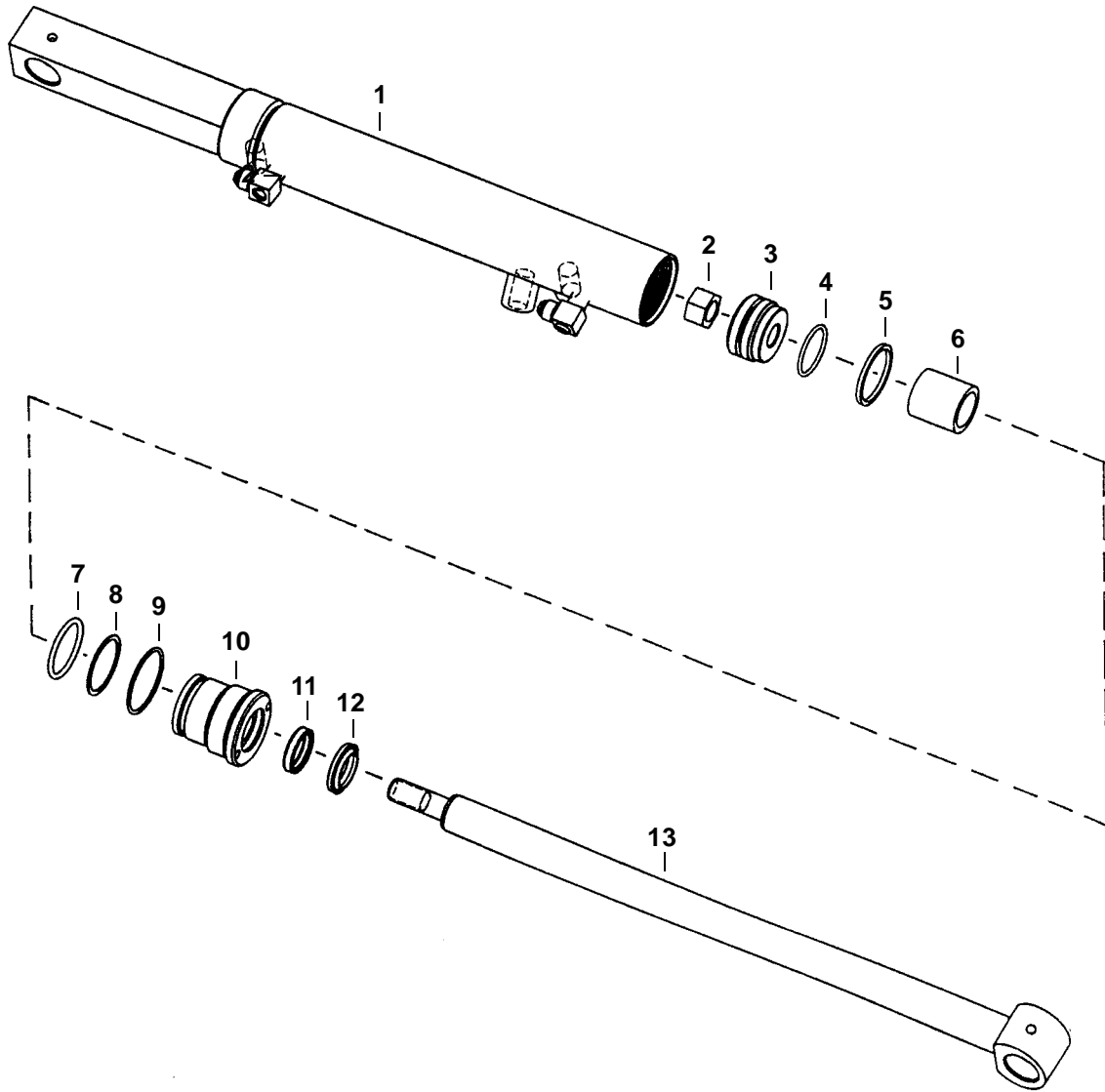

B-16207

MAIN RELIEF VALVE (CONT'D)

Removal And Installation

IMPORTANT

When repairing hydrostatic and hydraulic systems, clean the work area before disassembly and keep all parts clean. Always use caps and plugs on hoses, tubelines and ports to keep dirt out. Dirt can quickly damage the system.

I-2003-0888

Raise the operator cab. (See Raising on Page 10-30-2.)

Clean the area around the control valve.

NOTE: This procedure is for standard loaders, loaders equipped with ACS option and loaders equipped with SJC option. The main relief valve is located in the same place on all of the loaders.

Figure 20-30-6



NOTE: The right side motor cover if removed may provide better access to the main relief valve on some machines.

The main relief valve (Item 1) [Figure 20-30-6] is located at the lower front of the control valve below the lift and tilt spool connections.

Loosen and remove the main relief valve (Item 1) [Figure 20-30-6].

Figure 20-30-7



Remove the O-rings and back-up washers from the main relief valve [Figure 20-30-7].

Clean the main relief valve in clean solvent. Use air pressure to dry the valve.

Install new O-rings and back-up washers. Install the main relief valve and tighten [Figure 20-30-7].

Installation: Tighten the main relief valve to 47 - 54 N•m (35 - 40 ft-lb) torque.

Check the pressure again. (See Testing on Page 20-30-2.)

HYDRAULIC CONTROL VALVE (STANDARD) (CONT'D)

Anti-Cavitation Valve Removal And Installation (Lift, Rod End) (Cont'd)

Figure 20-40-24

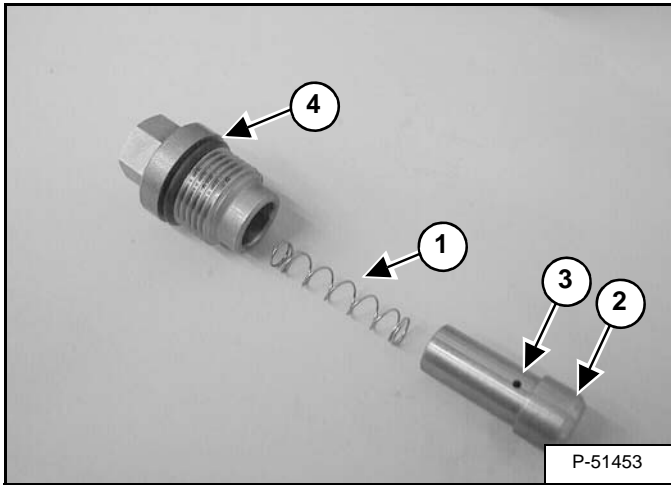

Remove the spring (Item 1) and poppet (Item 2) [Figure 20-40-24].

Check the orifice (Item 3) [Figure 20-40-24] in the poppet to be sure it is not plugged.

Installation: Install a new O-ring (Item 4) [Figure 20-40-24] on the plug and lightly lubricate with oil before installing. Tighten the plug to 52 - 61 N•m (38 - 45 ft-lb) torque.

Port Relief / Anti-Cavitation Valve Removal And Installation (Lift, Base End)

Figure 20-40-25

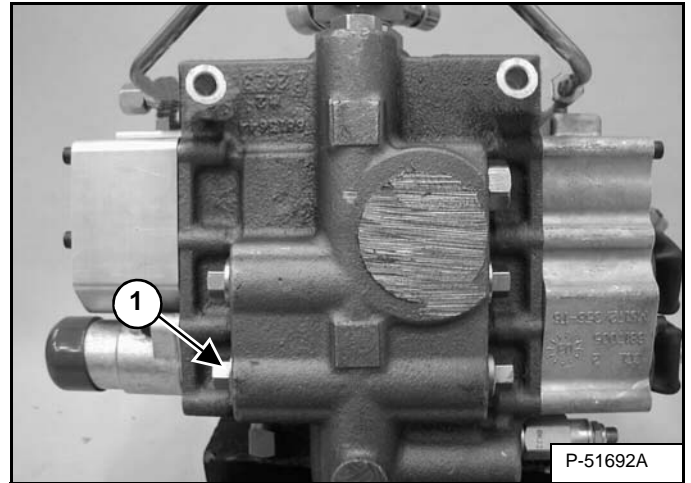

Loosen the lift circuit port relief / anti-cavitation valve (Item 1) [Figure 20-40-25].

Figure 20-40-26

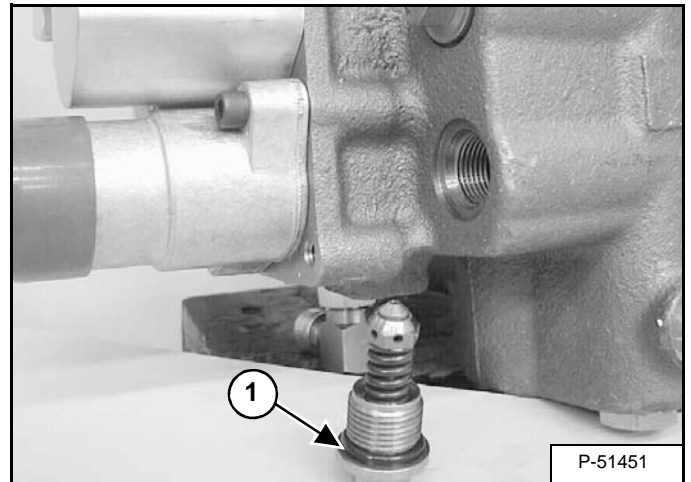

Replace the O-ring (Item 1) [Figure 20-40-26] before installation.

Installation: Tighten to 52 - 61 N•m (38 - 45 ft-lb) torque.

HYDRAULIC CONTROL VALVE (STANDARD) (CONT'D)

Lift Spool And Detent Removal And Installation (Cont'd)

Figure 20-40-60

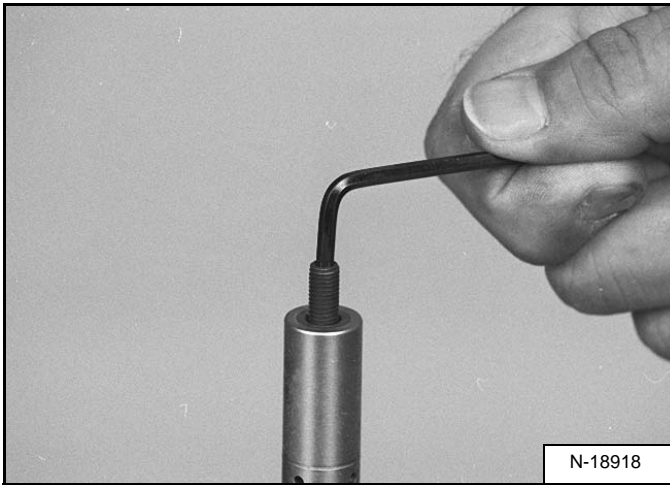

Remove the stud from the end of the spool [Figure 20-40-60].

Figure 20-40-61

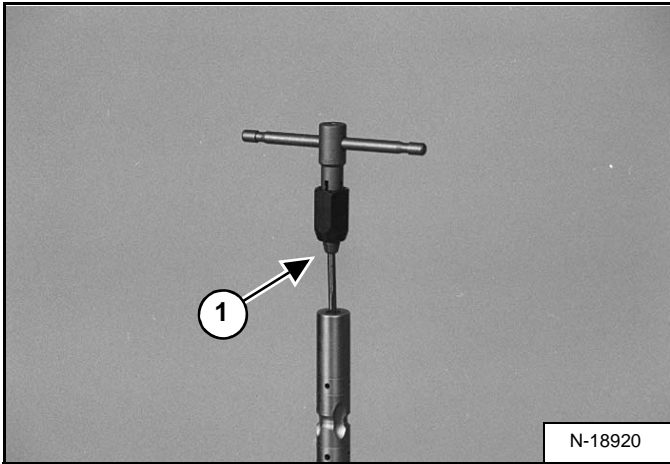

Removal of the plastic plug:

Make a center point in the plug using a 1,6 mm (1/16 in) drill.

Drill a hole all the way through the plug using a 2,8 mm (7/64 in) tap drill

Turn a 6-32 tap (Item 1) [Figure 20-40-61] into the plug. Pull the tap and plug out of the spool. Be careful, do not break the tap.

Clean all the debris from inside the spool bore.

NOTE: DO NOT USE Loctite® ON THE STUD THREADS.

Figure 20-40-62

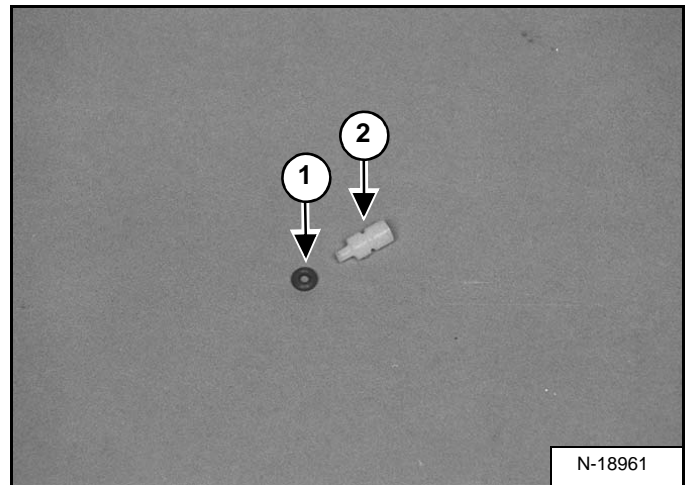

Install the O-ring (Item 1) over the nipple on the plastic plug (Item 2) [Figure 20-40-62].

NOTE: Check the O-ring for damage. The lift spool will have an internal leak if there is damage to this O-ring. Always replace the O-ring and recheck the lift spool before the control valve is replaced.

Figure 20-40-63

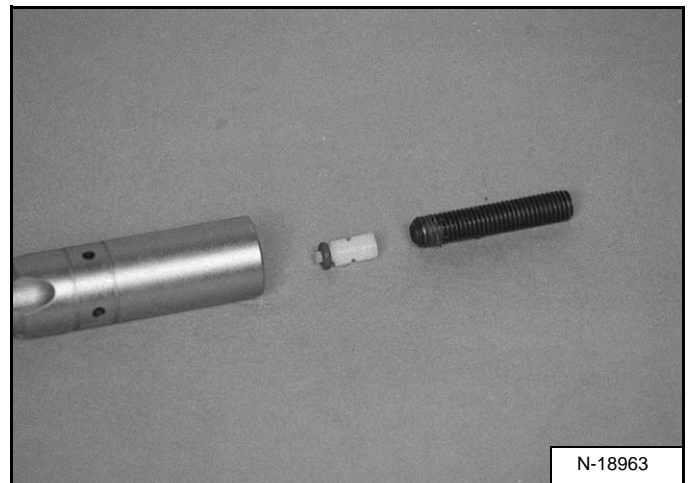

Install the plastic plug and O-ring in the spool [Figure 20-40-63].

HYDRAULIC CONTROL VALVE (STANDARD) (CONT'D)

Auxiliary Solenoid Removal And Installation (S/N A5GU34999 & Below And A5GV34999 & Below)

Figure 20-40-97

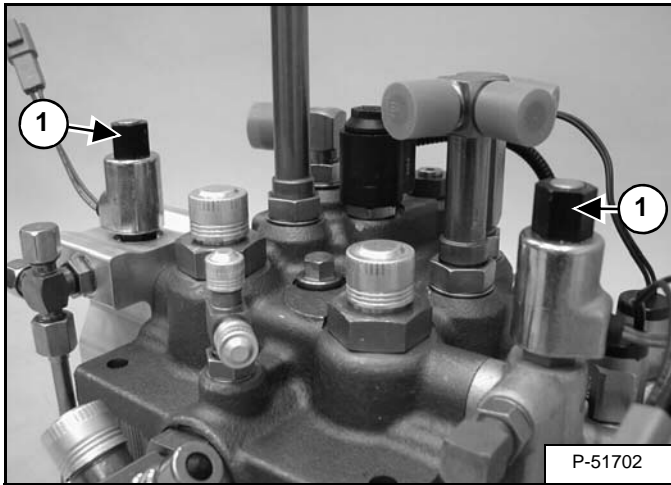

Remove the nut (Item 1) [Figure 20-40-97] from both solenoids.

Installation: Tighten the nut to 5 - 8 N•m (48 - 72 in-lb) torque.

Figure 20-40-98

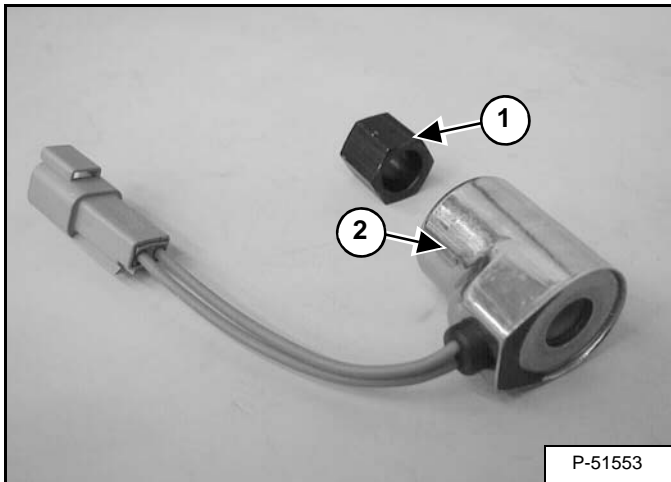

Remove the nut (Item 1) and solenoid coil (Item 2) [Figure 20-40-98].

Use an ohmmeter to measure the solenoid coil resistance.

The correct resistance for the coil is 4.9 ± 0.25 ohm.

Figure 20-40-99

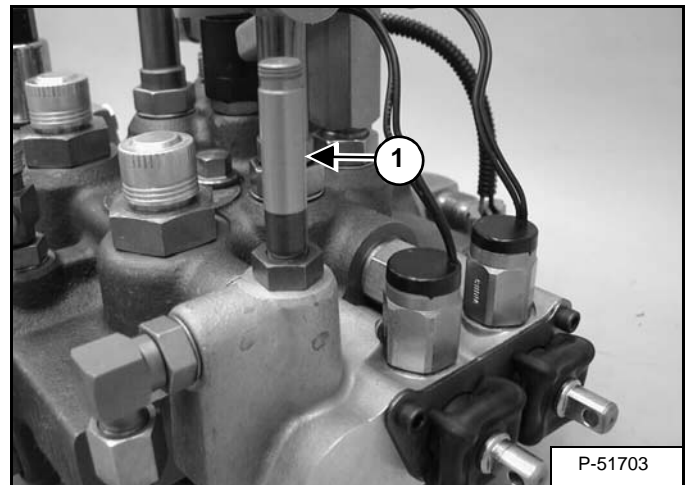

Remove the solenoid stem (Item 1) [Figure 20-40-99].

Installation: Tighten the stem to 14 - 19 N•m (10 - 14 ft-lb) torque.

Figure 20-40-100

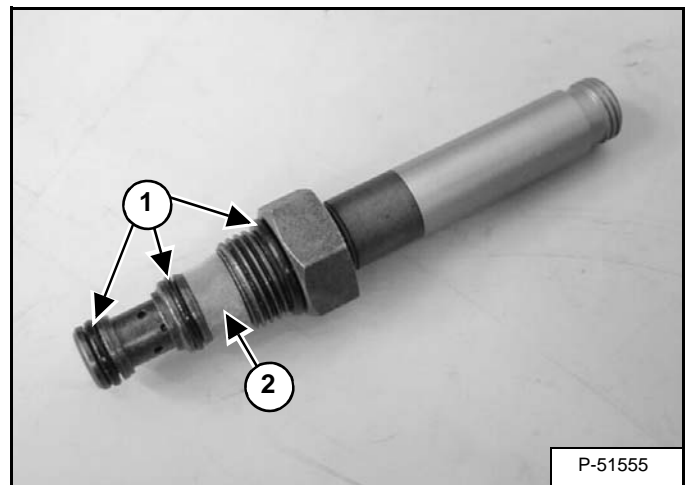

Remove the O-rings (Item 1) [Figure 20-40-100] from the solenoid stem.

Check and clean the screen (Item 2) [Figure 20-40-100].

HYDRAULIC CONTROL VALVE (ACS) OR (SJC) (CONT'D)

Removal And Installation (Cont'd)

Figure 20-41-5

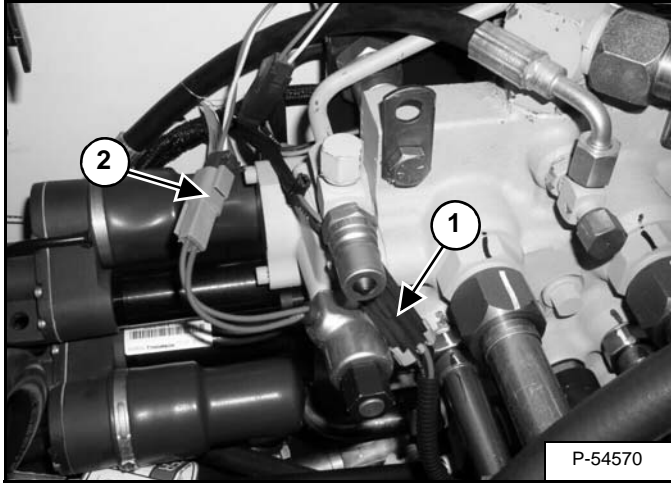

Mark the two wire connectors for proper installation.

Disconnect the wire harness connector (Item 1) from the BICS™ valve solenoid and (Item 2) from auxiliary valve solenoid [Figure 20-41-5].

Figure 20-41-6

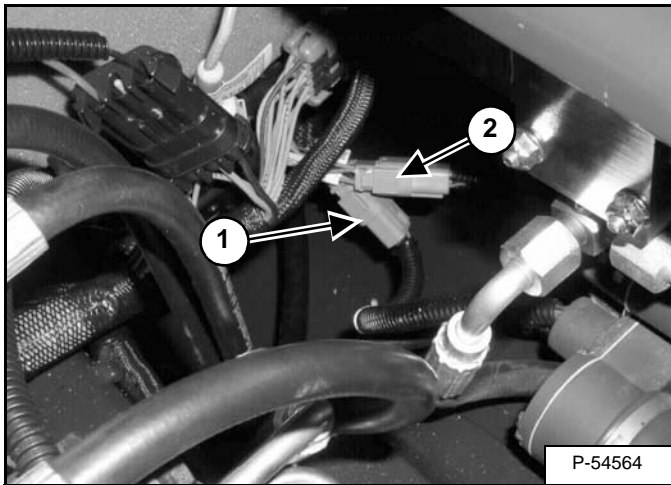

Disconnect the lift and tilt actuator electrical connectors (Item 1) and (Item 2) [Figure 20-41-6] from the control valve.

Figure 20-41-7

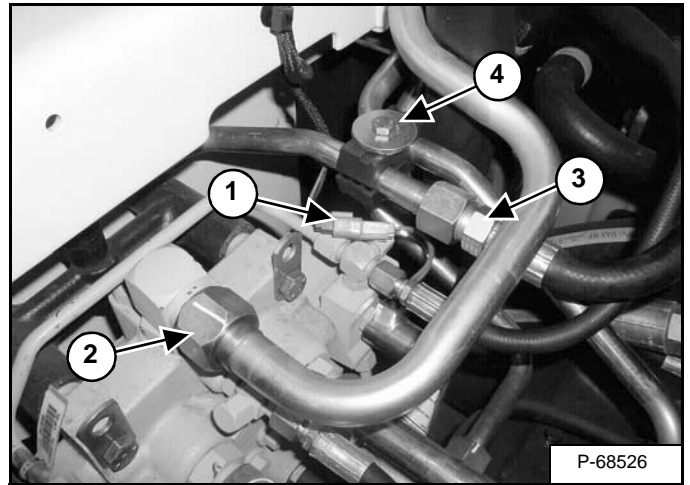

Disconnect the harness connector (Item 1) [Figure 20-41-7] from the auxiliary valve solenoid.

Disconnect the tubeline (Item 2) [Figure 20-41-7] that goes from the control valve to the hydraulic cooler.

Disconnect the hose (Item 3) [Figure 20-41-7] that goes from the gear pump to the control valve.

Remove the tubeline clamp (Item 4) [Figure 20-41-7].

Figure 20-41-8

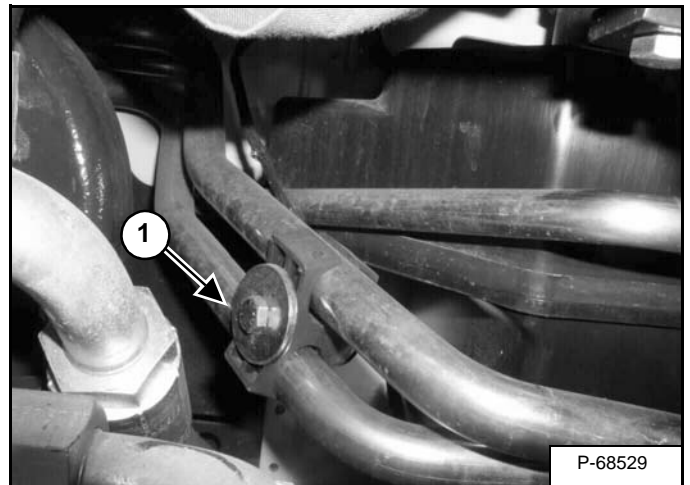

Remove the tubeline clamp (Item 1) [Figure 20-41-8] located on the auxiliary tubelines between the hydraulic reservoir and the hydrostatic pump.

Removing this clamp will allow more movement in the auxiliary tubelines for removing the control valve from the loader.

HYDRAULIC CONTROL VALVE (ACS) OR (SJC) (CONT'D)

Lift Load Check Valve Removal And Installation (Cont'd)

Figure 20-41-32

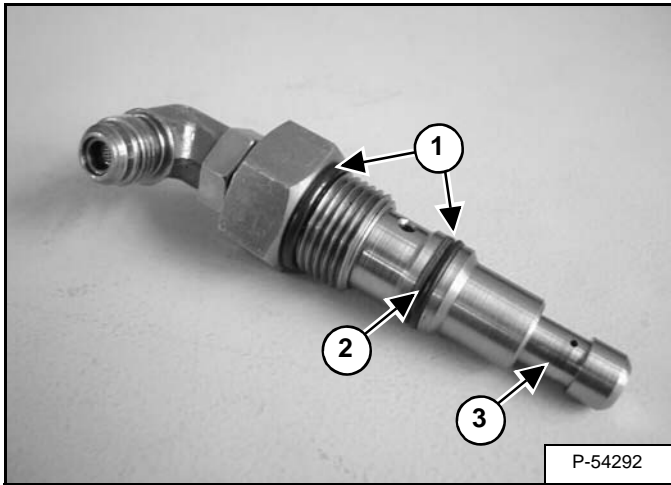

Remove and install new O-rings (Item 1) and back-up ring (Item 2) [Figure 20-41-32].

Check the load check valve (Item 3) [Figure 20-41-32].

Load Check Valve Removal And Installation (Tilt And Auxiliary)

Figure 20-41-33

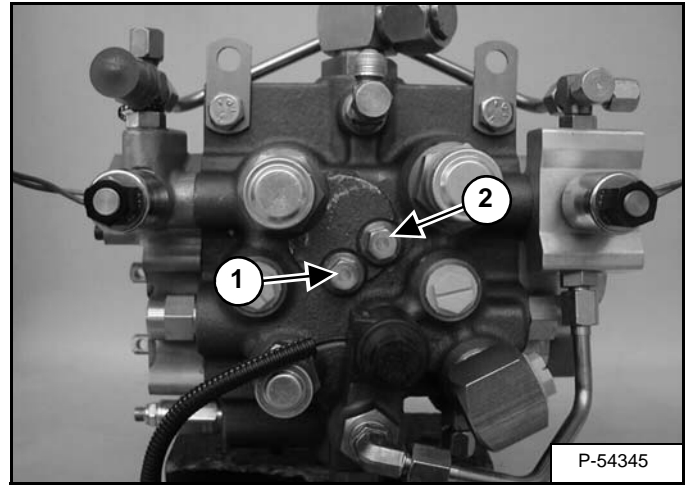

At the front side of the control valve locate the tilt section load check valve (Item 1) [Figure 20-41-33].

At the front side of the control valve locate the auxiliary section load check valve (Item 2) [Figure 20-41-33].

NOTE: The tilt and auxiliary load check valves are interchangeable.

Figure 20-41-34

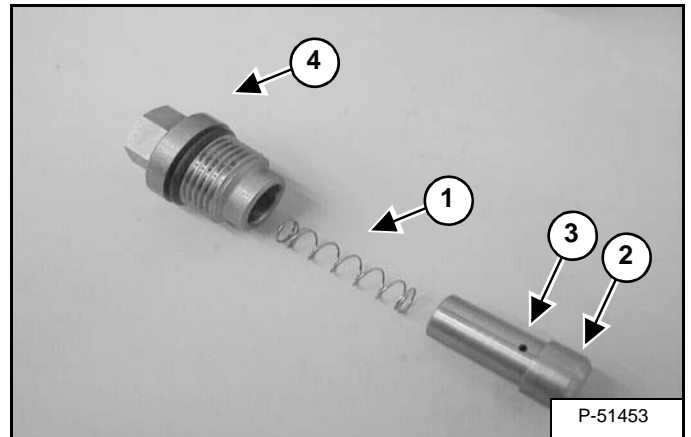

Remove the spring (Item 1) and poppet (Item 2) [Figure 20-41-34].

Check the orifice (Item 3) [Figure 20-41-34] in the poppet to be sure it is not plugged.

Installation: Install a new O-ring (Item 4) [Figure 20-41-34] on the plug and lightly lubricate with oil before installing. Tighten the plug to 52 - 61 N•m (38 - 45 ft-lb) torque.

HYDRAULIC CONTROL VALVE (ACS) OR (SJC) (CONT'D)

Lift Spool And Detent Removal And Installation (Cont'd)

Figure 20-41-69

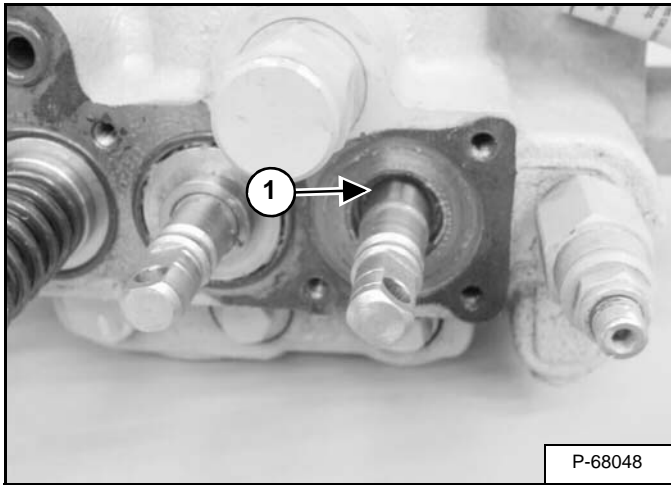

Install the spool seal (Item 1) [Figure 20-41-69] on the linkage end of the valve.

Figure 20-41-70

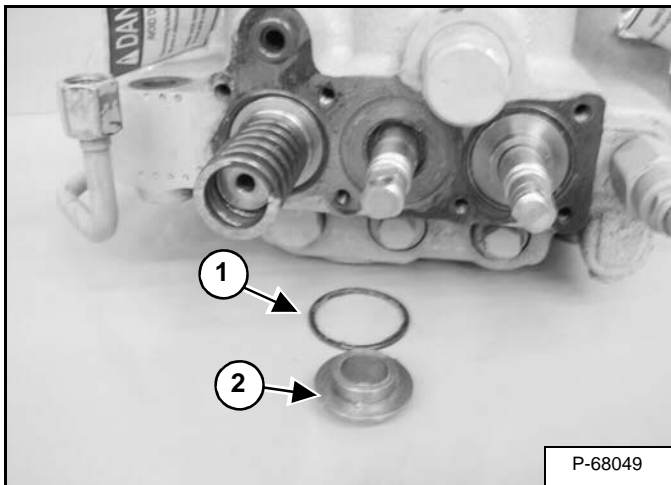

Install the O-ring (Item 1) and bushing (Item 2) [Figure 20-41-70] on the lift spool.

Figure 20-41-71

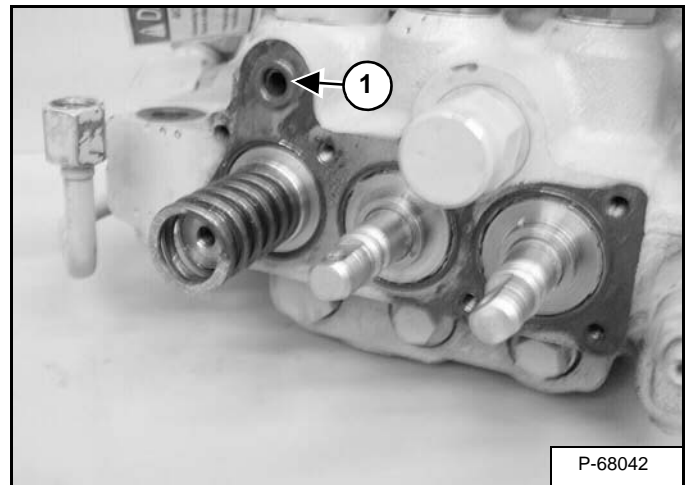

Install the O-ring (Item 1) [Figure 20-41-71] on the control valve.

Installation: Replace the O-ring, lubricate lightly with oil or grease before installation of the end cap block.

Figure 20-41-72

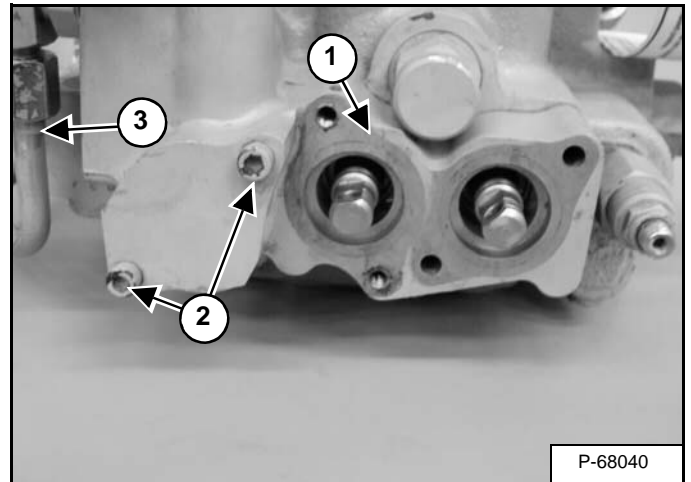

Install the end cap block (Item 1) and the two mount bolts (Item 2) [Figure 20-41-72].

Installation: Tighten the screws to 10,2 - 11,3 N•m (90 - 100 in-lb) torque.

Connect the tubeline (Item 3) [Figure 20-41-72] to the end cap block.

Install the lift and tilt actuators to the control valve.

HYDRAULIC CONTROL VALVE (ACS) OR (SJC) (CONT'D)

Lift Arm Bypass Orifice Removal And Installation

Figure 20-41-102

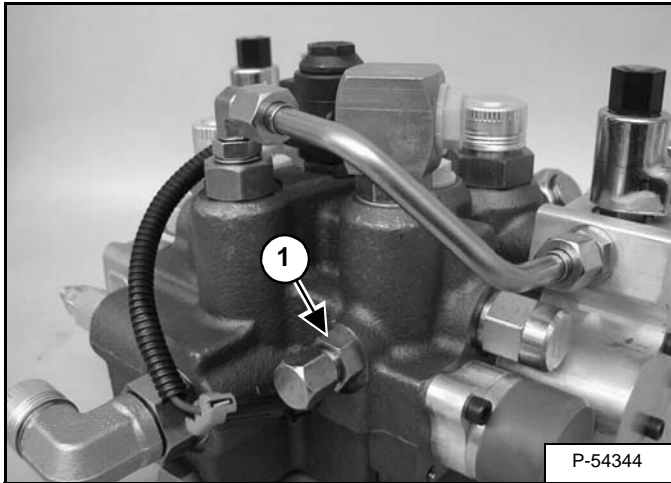

Remove the fitting (Item 1) [Figure 20-41-102] from the valve.

Figure 20-41-103

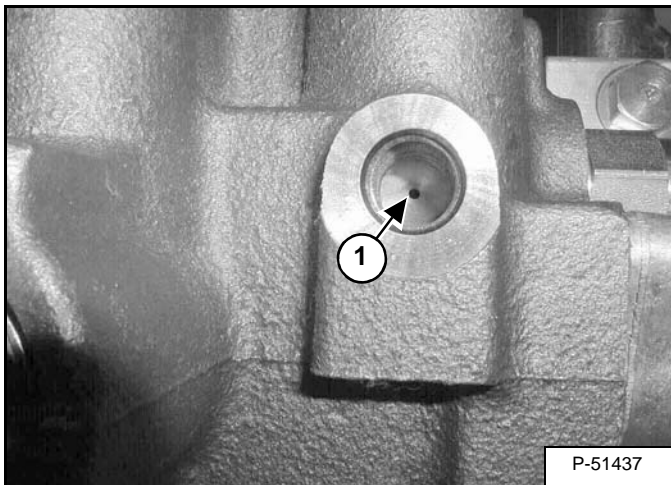

Check the lift arm bypass orifice (Item 1) [Figure 20-41-103].

NOTE: This orifice is not removable from the valve casting.

Main Relief Valve Removal And Installation

Figure 20-41-104

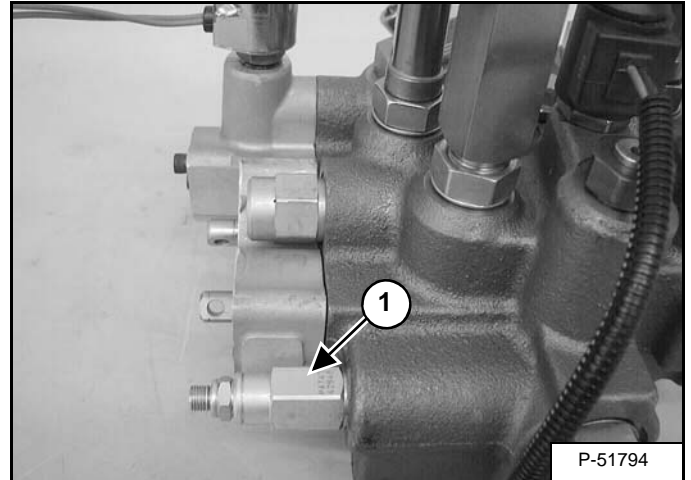

Remove the main relief valve (Item 1) [Figure 20-41-104].

Figure 20-41-105

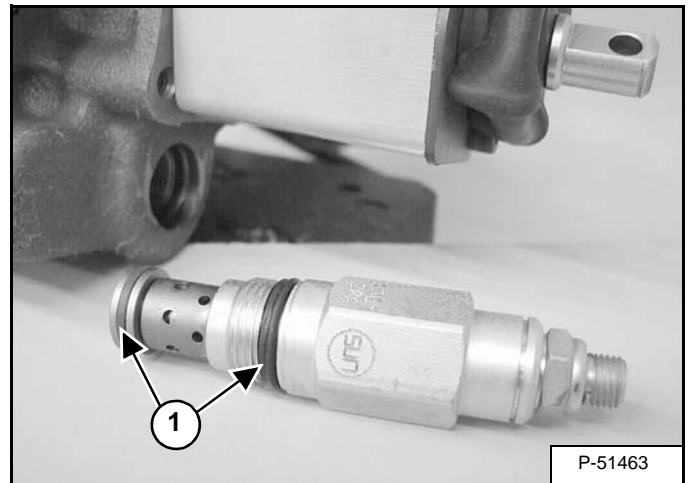

Remove the O-rings from the main relief valve (Item 1) [Figure 20-41-105].

Installation: Always use new O-rings. Tighten to 52 - 61 N•m (38 - 45 ft-lb) torque.

HYDRAULIC PUMP (STANDARD) (CONT'D)

Direct Pump Test (Charge Section) (Cont'd)

*Refer to the Hydraulic Schematics for pump flow and rpm.

Figure 20-60-15



Be sure all connections are tight and that the hoses are not touching any moving parts before starting the loader [Figure 20-60-15].

IMPORTANT

The hydraulic tester must be in the fully open position before you start the engine.

I-2024-0284

Start the engine and run at low idle rpm. Make sure the tester is connected correctly. If no flow is indicated on the tester, the hoses are connected wrong. With the hoses connected correctly, increase the engine speed to full rpm*.

Warm the fluid to 60°C (140°F) by turning the restrictor control (Item 1) on the tester to about 6894,8 kPa (68,9 bar) (1000 psi). DO NOT exceed system relief pressure. Open the restrictor control and record the free flow (L/min [U.S. gpm]) at full rpm.

Turn the restrictor down to system operating pressure. DO NOT EXCEED SYSTEM RELIEF PRESSURE. Refer to Hydraulic Schematics for pressure. The high pressure flow must be at least 80% of free flow.

$$\% = \frac{\text{HIGH PRESSURE FLOW (L/min [U.S. gpm])}}{\text{FREE FLOW (L/min [U.S. gpm])}} \times 100$$

A low percentage may indicate a failed pump.

*Refer to (See Hydraulic System on Page SPEC-10-2.) for system relief pressure and full rpm.

**HYDRAULIC PUMP (STANDARD) (HIGH FLOW)
(CONT'D)**

Direct Pump Test (Charge Section) (Cont'd)

Figure 20-61-7

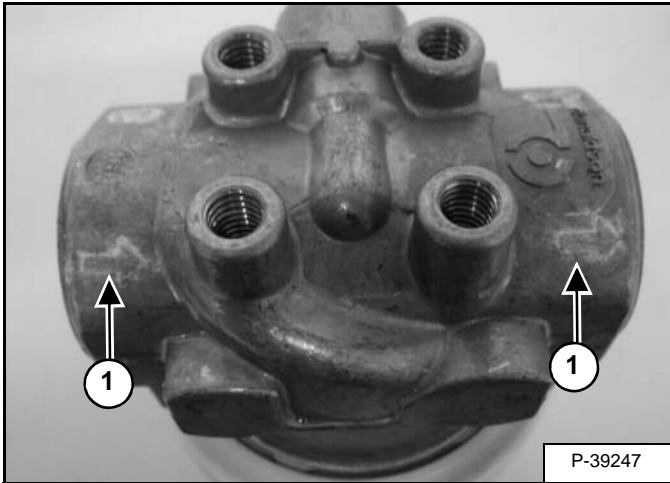

Determine the proper direction of oil flow through the filter housing (Item 1) [Figure 20-61-7] and [Figure 20-61-8].

Figure 20-61-8

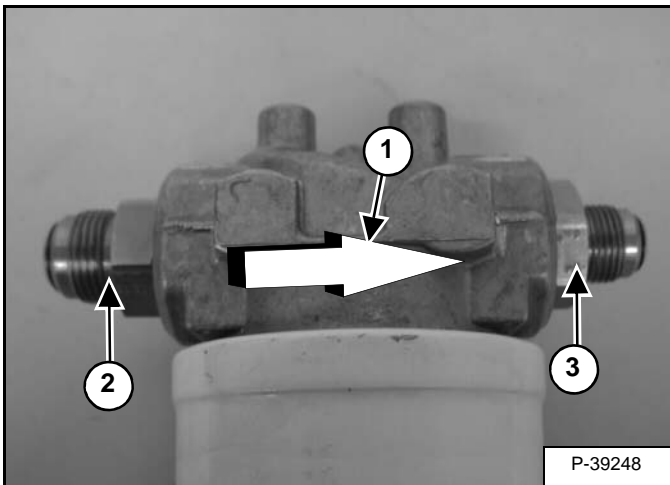

Install the fitting (15KB 1212-Straight Fitting) (Item 2) [Figure 20-61-8] in the filter housing inlet.

Install the fitting (15KB 0812-Reducer Fitting) (Item 3) [Figure 20-61-8] in the filter housing outlet.

Figure 20-61-9

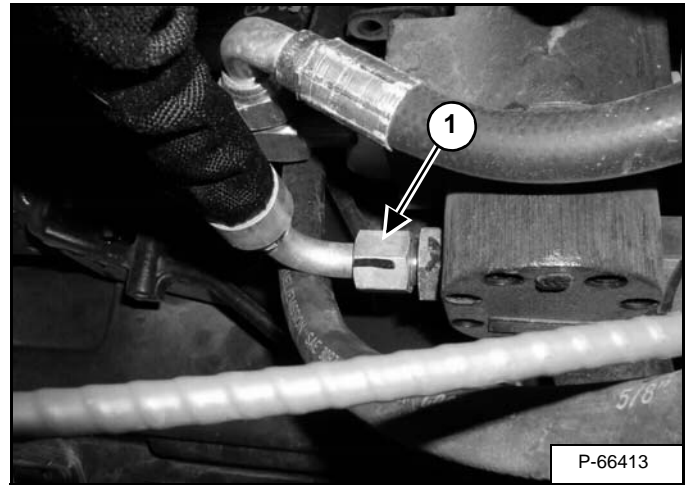

Disconnect the charge pump OUTLET hose (Item 1) [Figure 20-61-9] from the charge pump.

Figure 20-61-10

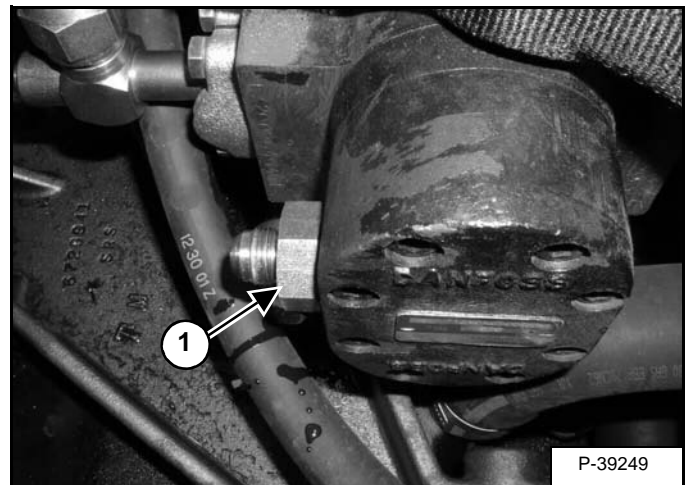

Remove the OUTLET fitting (Item 1) [Figure 20-61-10] from the charge pump.

HYDRAULIC PUMP (STANDARD) (HIGH FLOW) (CONT'D)

Removal And Installation (Cont'd)

Figure 20-61-34

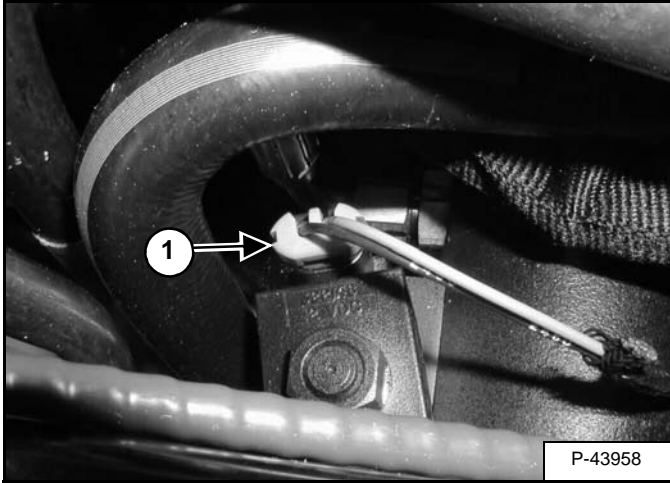

At the right side access hole, disconnect the electrical connector (Item 1) [Figure 20-61-34] from the high flow pump solenoid.

Figure 20-61-35

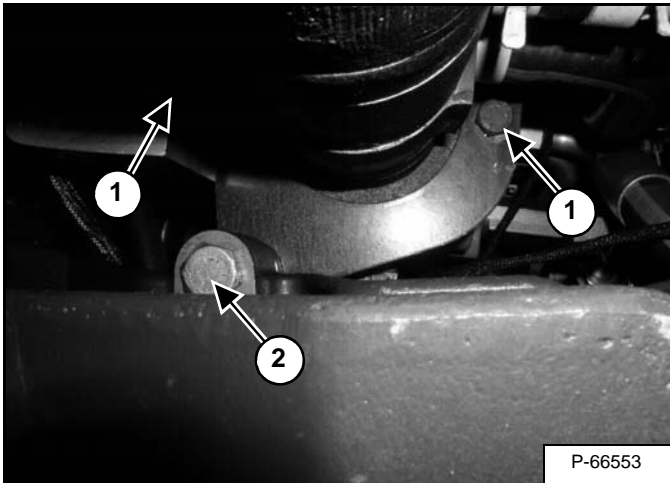

Remove the two mounting bolts (Item 1) [Figure 20-61-35] from the hydraulic pump.

Installation: Tighten the mounting bolts to 88 - 95 N•m (65 - 70 ft-lb) torque.

At the bottom side of the gear pump, remove the pump support bracket bolt (Item 2) [Figure 20-61-35] from pump support bracket.

Installation: Tighten the pump support bracket bolt to 237 - 257 N•m (175 - 190 ft-lb) torque.

Remove the hydraulic pump from the hydrostatic pump.

Remove the O-ring from the hydrostatic pump.

Installation: Use a new O-ring when installing the hydraulic pump.

HYDRAULIC PUMP (SJC) (CONT'D)

Direct Pump Test (Charge Section) (Cont'd)

*Refer to the Hydraulic Schematics for pump flow and rpm.

Figure 20-70-15



Be sure all connections are tight and that the hoses are not touching any moving parts before starting the loader [Figure 20-70-15].

IMPORTANT

The hydraulic tester must be in the fully open position before you start the engine.

I-2024-0284

Start the engine and run at low idle rpm. Make sure the tester is connected correctly. If no flow is indicated on the tester, the hoses are connected wrong. With the hoses connected correctly, increase the engine speed to full rpm*.

Warm the fluid to 60°C (140°F) by turning the restrictor control (Item 1) on the tester to about 6894,8 kPa (68,9 bar) (1000 psi). DO NOT exceed system relief pressure. Open the restrictor control and record the free flow (L/min [U.S. gpm]) at full rpm.

Turn the restrictor down to system operating pressure. DO NOT EXCEED SYSTEM RELIEF PRESSURE. Refer to Hydraulic Schematics for pressure. The high pressure flow must be at least 80% of free flow.

$$\% = \frac{\text{HIGH PRESSURE FLOW (L/min [U.S. gpm])}}{\text{FREE FLOW (L/min [U.S. gpm])}} \times 100$$

A low percentage may indicate a failed pump.

*Refer to (See Hydraulic System on Page SPEC-10-2.) for system relief pressure and full rpm.

HYDRAULIC PUMP (SJC) (HIGH FLOW) (CONT'D)

Direct Pump Test (Charge Section)

The tools listed will be needed to do the following procedure:

MEL1563 or 7003031 - Remote Start Tool
MEL10003 - Hydraulic Tester
MEL10006 - Hydraulic Test Kit
6661247 - Filter Assembly
17 KB 1212 - Elbow Fitting
15 KB 1212 - Straight Fitting
15 KB 0812 - Reducer Fitting

WARNING

Put jackstands under the front axles and rear corners of the frame before running the engine for service. Failure to use jackstands can allow the machine to fall or move and cause injury or death.

W-2017-0286

Lift and block the loader. (See Procedure on Page 10-10-1.)

Raise the lift arms and install an approved lift arm support device. (See Installing on Page 10-20-1.)

WARNING

Never work on a machine with the lift arms up unless the lift arms are secured by an approved lift arm support device. Failure to use an approved lift arm support device can allow the lift arms or attachment to fall and cause injury or death.

W-2059-0598

NOTE: The fluid from the charge pump must be filtered after it passes through the Hydraulic Tester, to prevent any contamination to the Hydrostatic Pumps.

Raise the operator cab. (See Raising on Page 10-30-2.)

Open the rear door of the loader.

Connect the remote start tool. (See REMOTE START TOOL KIT-MEL1563 on Page 10-60-1.)

Figure 20-71-5

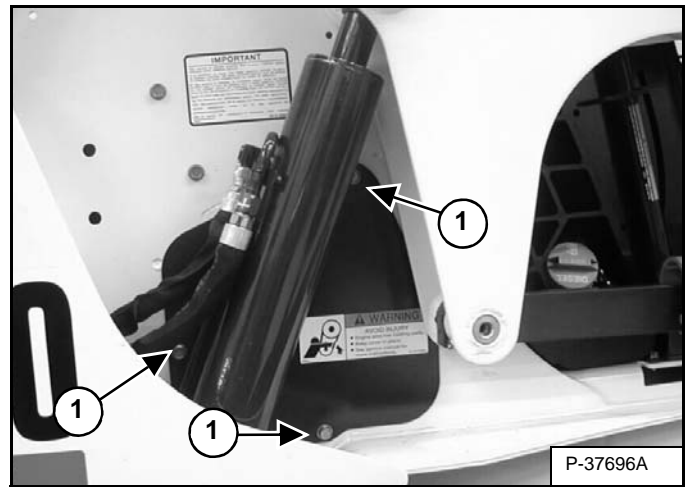

Remove the three mount bolts (Item 1) [Figure 20-71-5] from the right side access panel. Remove the panel.

Figure 20-71-6

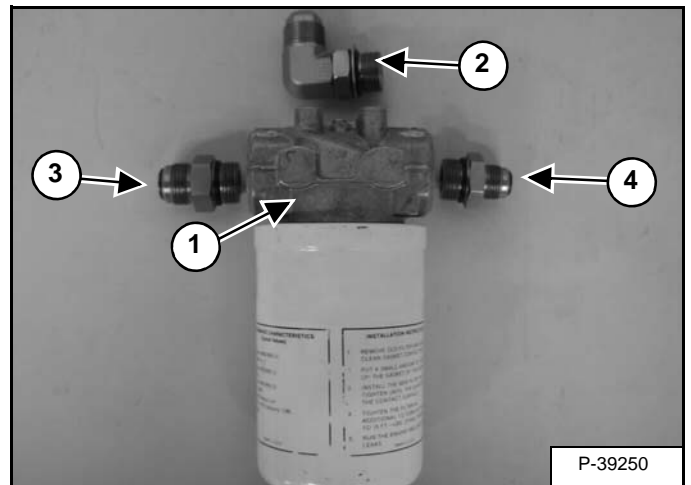

Assemble the filter assembly (Item 1), elbow fitting (Item 2), straight fitting (Item 3) and the reducer fitting (Item 4) [Figure 20-71-6].

HYDRAULIC PUMP (SJC) (HIGH FLOW) (CONT'D)

Removal And Installation



P-90328

AVOID DEATH

- Disconnecting or loosening any hydraulic tubeline, hose, fitting, component or a part failure can cause lift arms to drop.
- Keep out of this area when lift arms are raised unless supported by an approved lift arm support. Replace if damaged.

D-1009-0409



Never work on a machine with the lift arms up unless the lift arms are secured by an approved lift arm support device. Failure to use an approved lift arm support device can allow the lift arms or attachment to fall and cause injury or death.

W-2059-0598

Raise the lift arms and install an approved lift arm support device. (See Installing on Page 10-20-1.)

Stop the engine. Raise the seat bar.

Lift and block the rear of the loader. (See Procedure on Page 10-10-1.)

Raise the operator cab. (See Raising on Page 10-30-2.)

Drain the hydraulic fluid from the reservoir. (See HYDRAULIC / HYDROSTATIC SYSTEM on Page 10-120-1.)

Open the rear door of the loader.

Remove the hoses from the Power Bob-Tach block. (If so equipped.) (See Removal And Installation on Page 20-130-1.)

Figure 20-71-32

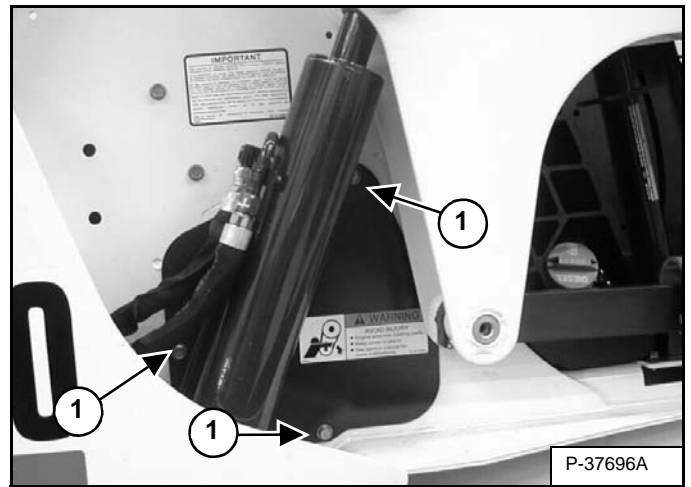

Remove the three mount bolts (Item 1) [Figure 20-71-32] from the right side access panel. Remove the panel.

Figure 20-71-33

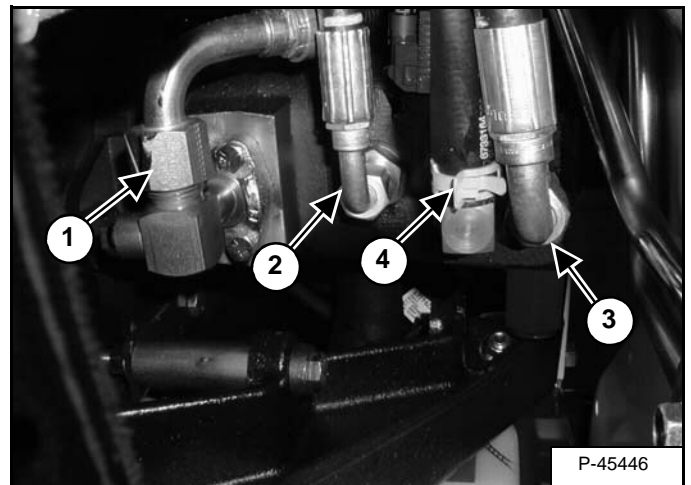

At the back side of the gear pump, disconnect and cap the hose from the outlet fitting (Item 1) of the standard flow pump. Disconnect and cap the hose (Item 2) from the charge pump. Disconnect and cap the hoses from the High Flow pump outlet fitting (Item 3) and the low pressure hose (Item 4) [Figure 20-71-33].

HYDRAULIC FLUID RESERVOIR (CONT'D)

Removal And Installation (Cont'd)

Figure 20-90-6

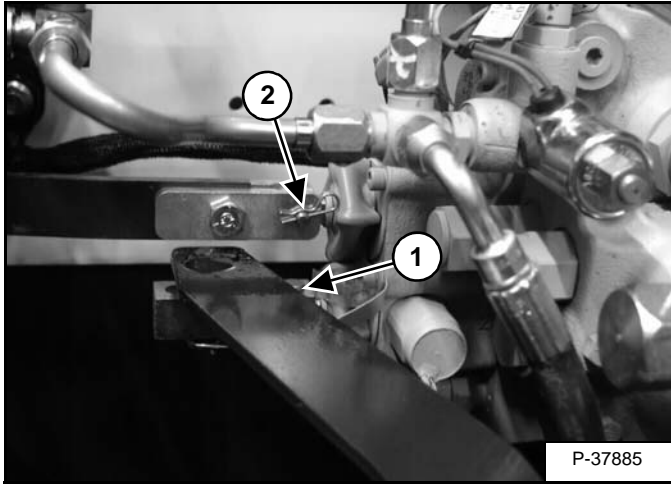

Remove the linkage pin (Item 1) [Figure 20-90-6] from the tilt linkage bar, and remove the linkage bar from the control valve lift spool.

Remove the hairpin clip from the crossmember pin.

Remove the crossmember and lift linkage bar from the pivot, and the loader.

Figure 20-90-7

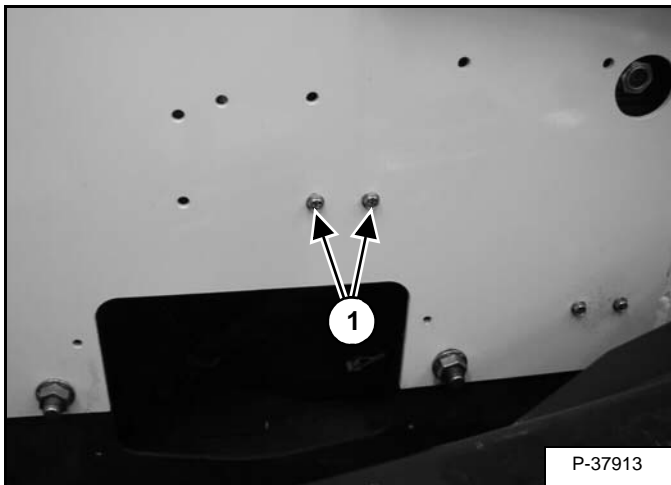

At the left fender, remove the two mount bolts (Item 1) [Figure 20-90-7] from the front reservoir mount bracket.

Remove the mount bracket from the loader.

Figure 20-90-8

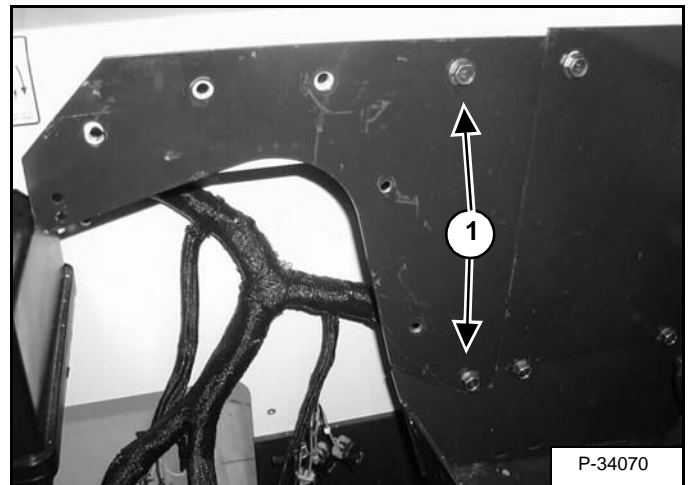

Remove the two mount bolts (Item 1) [Figure 20-90-8] from the side panel.

Remove the side panel from the loader.

Figure 20-90-9

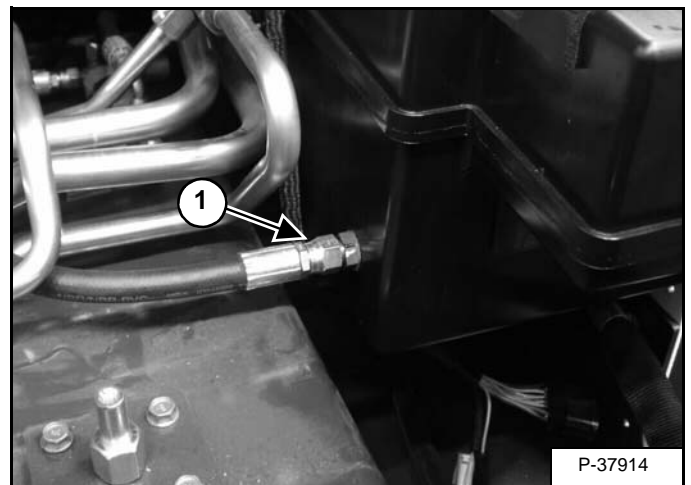

Disconnect the hose (Item 1) [Figure 20-90-9] from the reservoir.

REAR AUXILIARY DIVERTER VALVE

Description

The rear auxiliary diverter valve is an optional valve that diverts oil from the front auxiliary circuit to two sets of rear auxiliary couplers or the right side auxiliaries. The couplers are used for rear mounted attachments. The right side auxiliaries are used for older attachments.

The rear couplers are located, one set on each side of the rear frame uprights.

The right side auxiliaries are located on the inside of the right side lift arm at the front of the machine.

The rear auxiliary valve is located on the right side of the machine behind the blower housing. The valve is accessed by remove a panel on the right side of the machine.

See Hydraulic Schematic for more circuit information.

Solenoid Testing

Figure 20-120-1

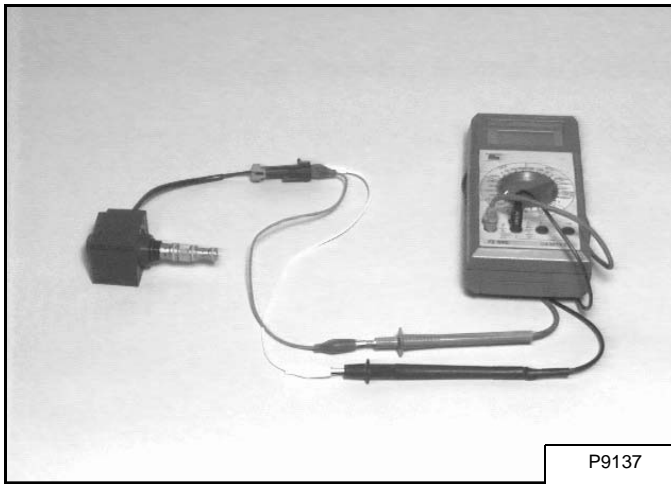

Use a test meter to measure coil resistance [Figure 20-120-1]. Coil wires do not have polarity. Correct resistance is 8.6 - 9.5 ohm.

Replace the test meter with 12 volt power. You can see and hear the spool shift.

BOB-TACH (POWER) BLOCK

Description

The power Bob-Tach block is an option that allows the operator to hydraulically control the Bob-Tach levers for mounting and dismounting the attachments.

The power Bob-Tach is operated by a switch on the front console.

The power Bob-Tach block is mounted on the right side of the machine in front of the engine on the backside of the hydraulic pump.

Removal And Installation

WARNING

Never work on a machine with the lift arms up unless the lift arms are secured by an approved lift arm support device. Failure to use an approved lift arm support device can allow the lift arms or attachment to fall and cause injury or death.

W-2059-0598

DANGER

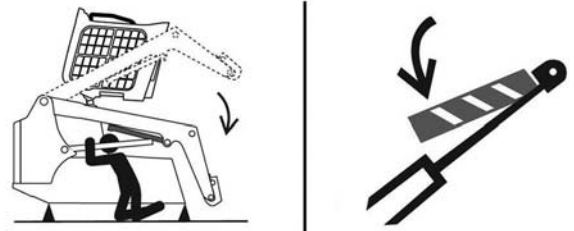

P-90328

AVOID DEATH

- Disconnecting or loosening any hydraulic tubeline, hose, fitting, component or a part failure can cause lift arms to drop.
- Keep out of this area when lift arms are raised unless supported by an approved lift arm support. Replace if damaged.

D-1009-0409

IMPORTANT

When repairing hydrostatic and hydraulic systems, clean the work area before disassembly and keep all parts clean. Always use caps and plugs on hoses, tubelines and ports to keep dirt out. Dirt can quickly damage the system.

I-2003-0888

HYDROSTATIC SYSTEM

CASE DRAIN FILTER	30-60-1
Description	30-50-1
Disassembly And Assembly	30-60-1
CHARGE PRESSURE	30-30-1
Adjusting	30-30-4
Description	30-30-1
Sender Removal And Installation	30-30-3
Testing	30-30-1
DRIVE BELT	30-50-1
Adjusting	30-50-2
Belt Removal And Installation	30-50-2
Description	30-50-1
Shield Removal And Installation	30-50-1
Tensioner Pulley Disassembly And Assembly	30-50-4
Tensioner Pulley Removal And Installation	30-50-3
Tensioner Pulley Tension Spring Disassembly And Assembly	30-50-5
Tensioner Pulley Tension Spring Removal And Installation	30-50-5
HYDROSTATIC DRIVE MOTOR	30-20-1
Description	30-20-1
Disassembly And Assembly	30-20-6
Parts Identification	30-20-4
Removal And Installation	30-20-2
Removing And Replacing Oil	30-20-1
HYDROSTATIC PUMP	30-40-1
Assembly	30-40-13
Description	30-40-1
Disassembly	30-40-6
Hydrostatic Pump Startup	30-40-2
Parts Identification (Left Half)	30-40-4
Parts Identification (Right Half)	30-40-5
Removal And Installation	30-40-1
Replenishing / High Pressure Relief Valve Removal And Installation	30-40-3

HYDROSTATIC SYSTEM

Continued On Next Page

HYDROSTATIC DRIVE MOTOR (CONT'D)

Disassembly And Assembly (Cont'd)

Figure 30-20-10

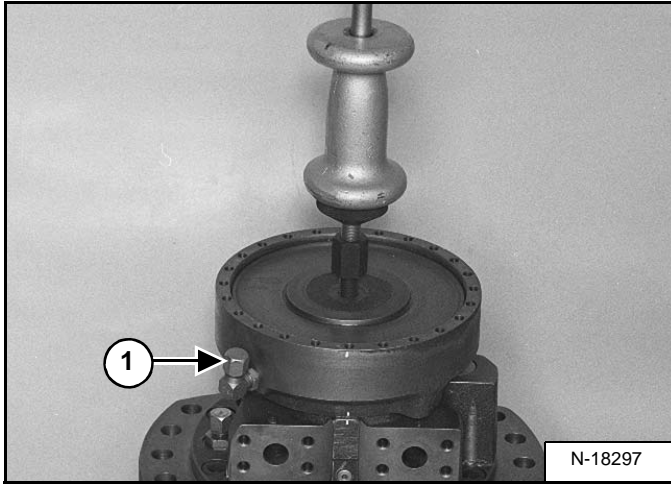

Remove the piston from the brake housing [Figure 30-20-10].

NOTE: The use of air pressure through the brake line connection (Item 1) [Figure 30-20-10] will aid in piston removal.

Figure 30-20-11

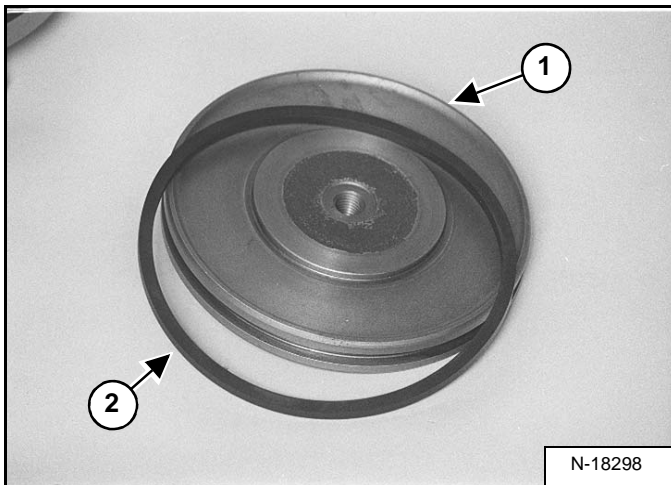

Check the brake piston (Item 1) [Figure 30-20-11] for damage including the surface that contacts the brake shaft.

Replace the seal (Item 2) [Figure 30-20-11].

Assembly: Apply oil to the seal (Item 2) [Figure 30-20-11] for added protection when installing the brake piston.

Figure 30-20-12

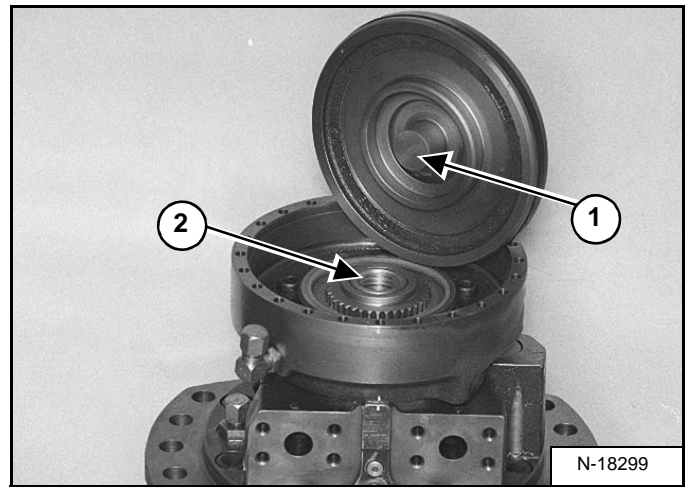

Check the piston surface (Item 1) and the bushing surface (Item 2) [Figure 30-20-12] in the brake shaft.

NOTE: The bushing (Item 2) [Figure 30-20-12] can be replaced in the brake shaft. When the bushing is replaced, install the bushing flush with the top of the brake shaft.

HYDROSTATIC DRIVE MOTOR (CONT'D)

Disassembly And Assembly (Cont'd)

Figure 30-20-48

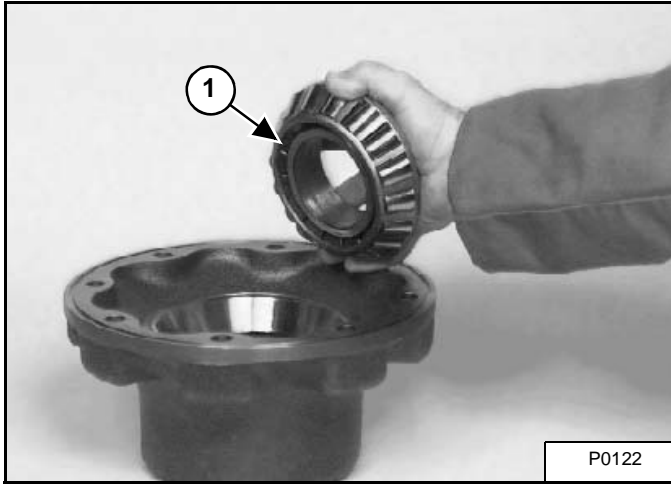

Remove and inspect the bearing (Item 1) [Figure 30-20-48] located in the front housing.

Replace the bearing if worn or damaged.

Figure 30-20-49

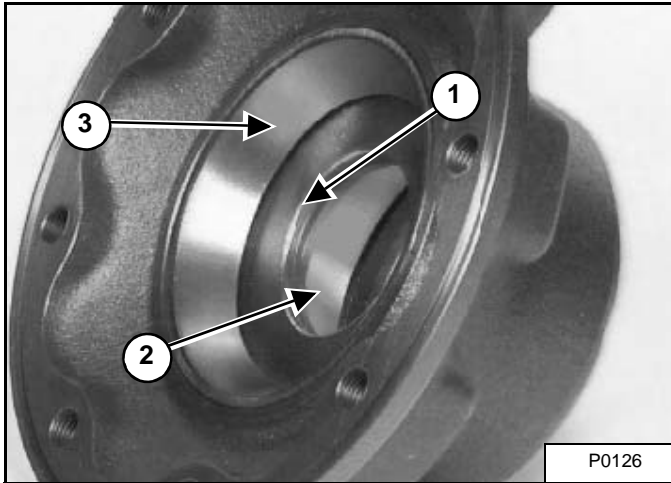

Remove the shaft seal (Item 1) [Figure 30-20-49].

Replace the outer O-ring and inner shaft seal (Item 2) [Figure 30-20-49].

Remove the bearing cup (Item 3) [Figure 30-20-49] if it needs replacement.

Figure 30-20-50

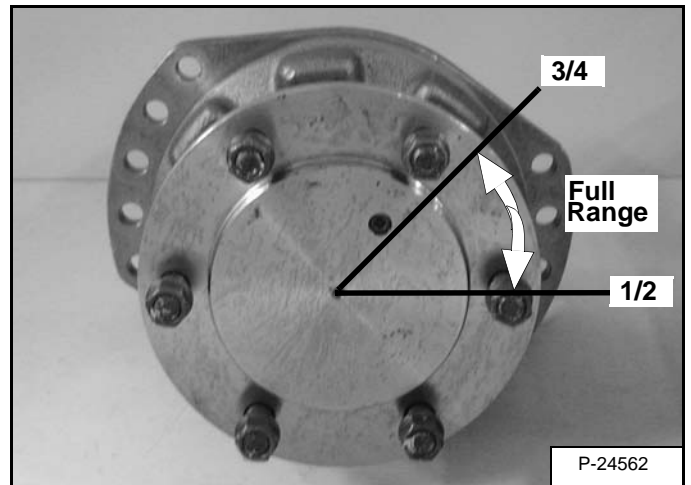

Fill housing with synthetic Mobilgear SHC XMP 150 to [Figure 30-20-50] 1/2 to 3/4 full.

HYDROSTATIC PUMP (CONT'D)

Replenishing / High Pressure Relief Valve Removal And Installation

Figure 30-40-8

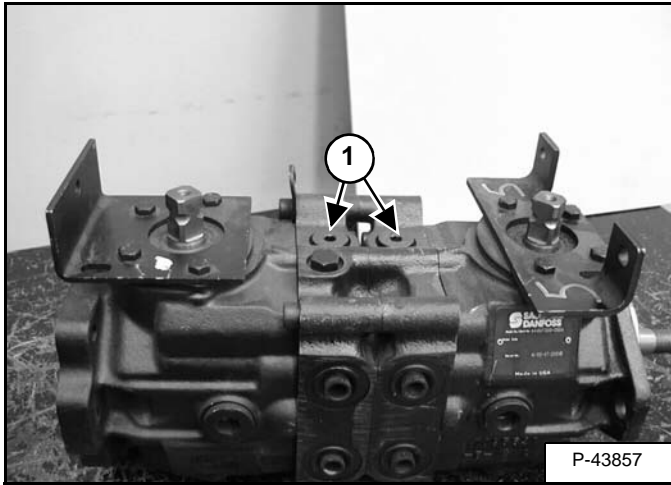

There are four replenishing / high pressure relief valves (Item 1) [Figure 30-40-8] in the hydrostatic pump assembly. Two are located at the top of the pumps and two at the bottom of the pumps for valve function.

NOTE: The two top valves are for the reverse drive loop and the two bottom valves are for the forward drive loop.

Figure 30-40-9

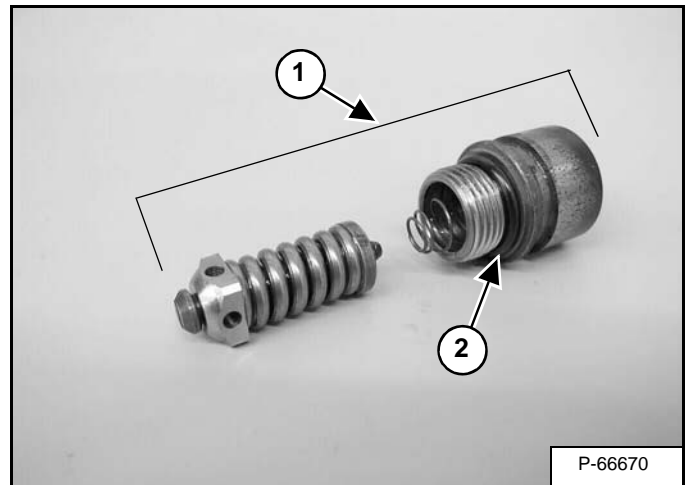

Remove the high pressure relief valve (Item 1) [Figure 30-40-8] and [Figure 30-40-9] from the pump.

Assemble: Tighten the plug to 41 - 68 N•m (30 - 50 ft-lb) torque.

Check for damage and replace as needed.

Check the O-ring (Item 2) [Figure 30-40-9] for damage and replace as needed.

If the high pressure relief valve must be replaced, it must be replaced as a complete unit.

The pressure setting for a new high pressure relief valve is 34473,8 kPa (344,7 bar) (5000 psi).

HYDROSTATIC PUMP (CONT'D)

Assembly

Figure 30-40-37

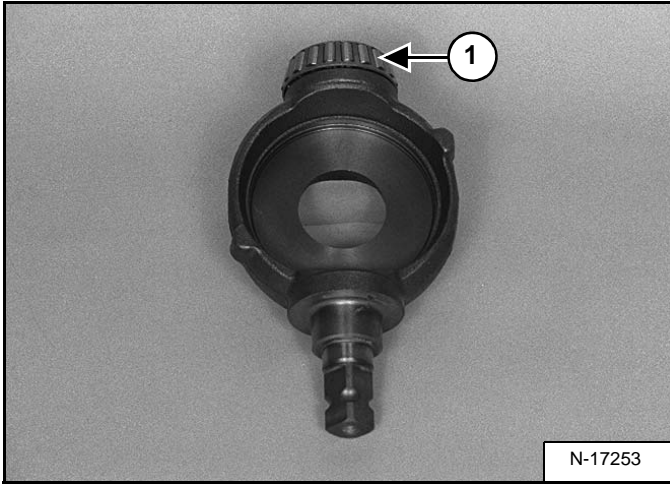

Install the lower bearing (Item 1) [Figure 30-40-37] on the swash plate.

Figure 30-40-38

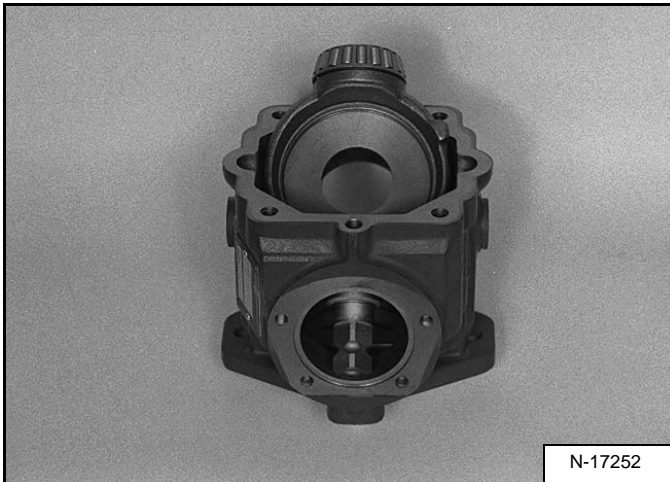

Install the swash plate and bearing into the pump housing [Figure 30-40-38].

Figure 30-40-39

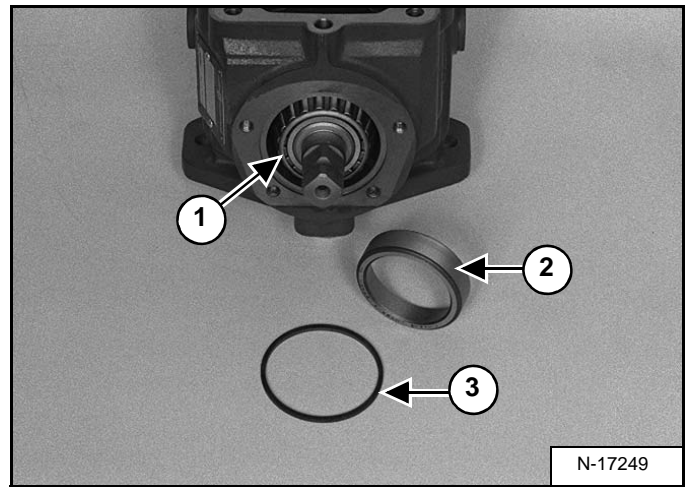

Install the tapered bearing (Item 1) [Figure 30-40-39] on the swash plate shaft.

Figure 30-40-40

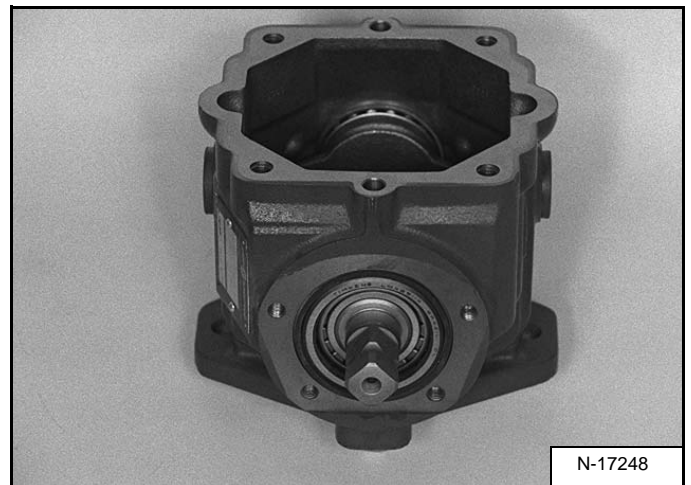

Install the bearing race (Item 2) [Figure 30-40-39] and O-ring (Item 3) [Figure 30-40-39] as shown in [Figure 30-40-40].

HYDROSTATIC PUMP (SJC) (S/N A5GU20001 - A5GU35031 AND A5GV20001 - A5GV35000) (CONT'D)

Removal And Installation (Cont'd)

Figure 30-41-12

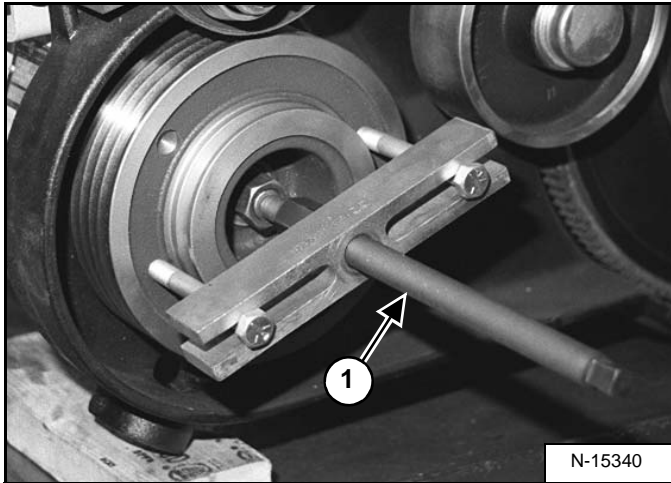

Install the nut on the end of the pump drive shaft (without washer).

Use a puller (Item 1) [Figure 30-41-12] to remove the pulley from the pump drive shaft.

NOTE: DO NOT strike puller or pump shaft with a hammer. Internal pump damage may result.

Remove the nut and washer from the pump drive shaft.

Remove the pump pulley from the pump drive shaft.

Figure 30-41-13

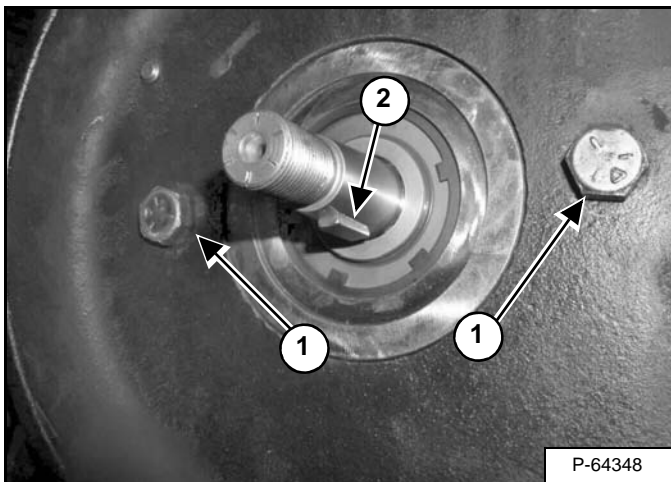
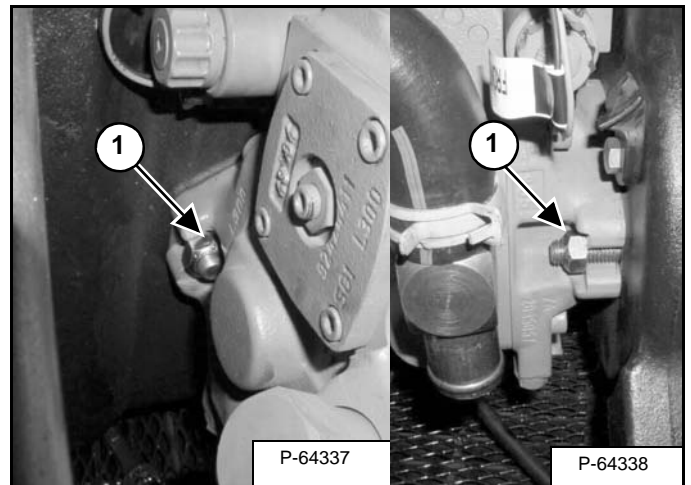

Figure 30-41-14



Remove the two mounting bolts (Item 1) [Figure 30-41-13] and nuts (Item 1) [Figure 30-41-14].

Installation: Tighten the mounting bolts and nuts to 88 - 95 N•m (65 - 70 ft-lb) torque.

Make sure the key (Item 2) [Figure 30-41-13] is installed.

Remove the hydrostatic pump from the mounting bracket and drive belt housing.

Figure 30-41-15

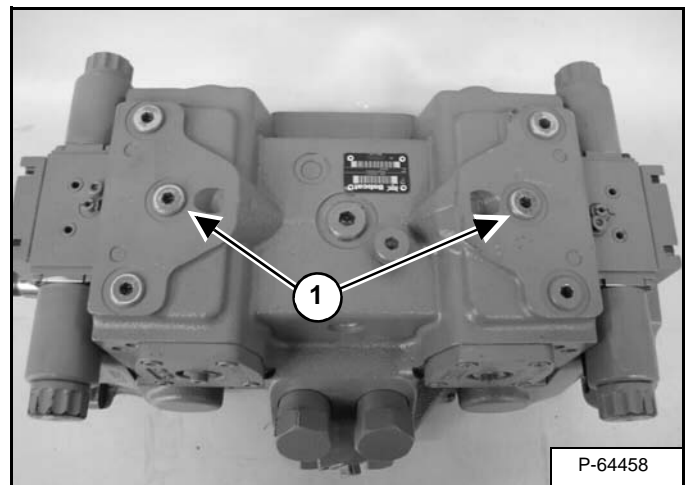

Remove the air bleed plugs (Item 1) [Figure 30-41-15].

BEFORE START UP: Fill one of the air bleed ports with new hydraulic oil until the hydraulic oil flows out of the other air bleed port. This will remove trapped air in the hydrostatic pumps before start up.

Assembly: Tighten plugs to 25 N•m (18 ft-lb) torque.

HYDROSTATIC PUMP (SJC) (S/N A5GU20001 - A5GU35031 AND A5GV20001 - A5GV35000) (CONT'D)

Disassembly And Assembly (Cont'd)

Figure 30-41-37

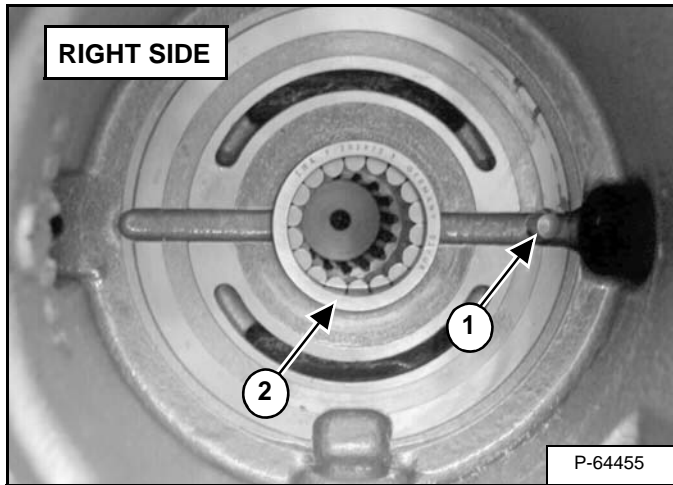

Figure 30-41-38

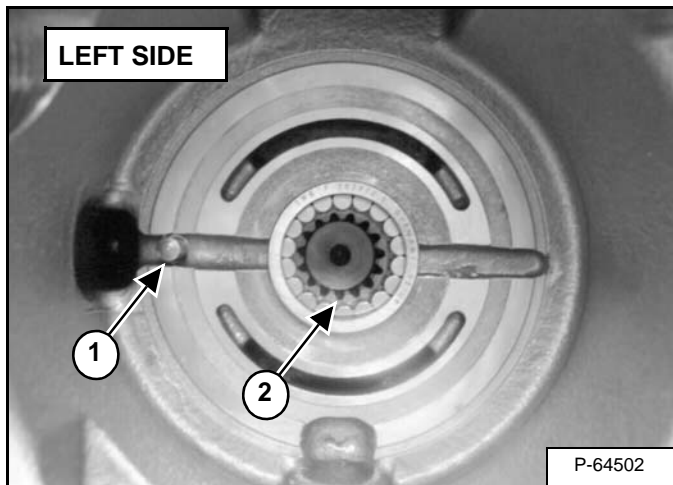

Figure 30-41-39

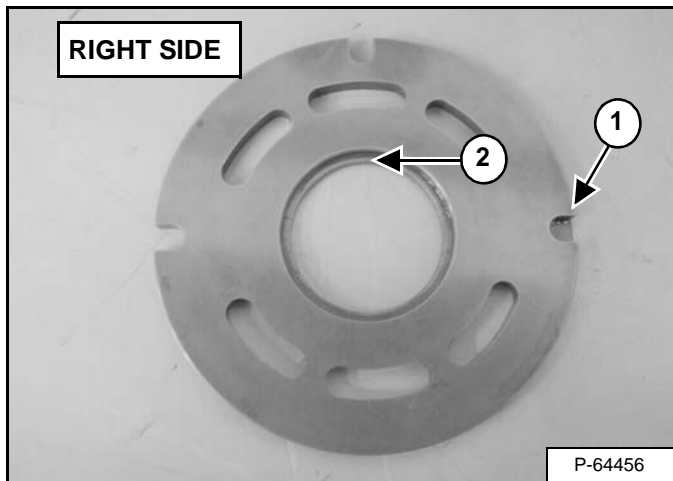
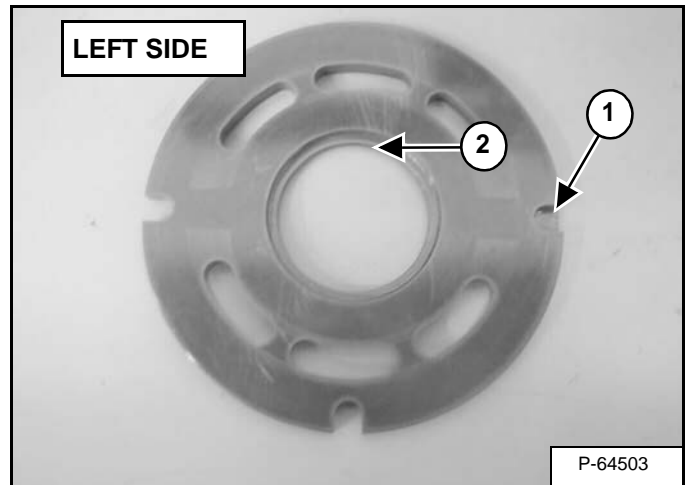

Figure 30-41-40



Assembly: Align the timing pin (Item 1) [Figure 30-41-37] and [Figure 30-41-38] in the case housing with the notch (Item 1) [Figure 30-41-39] and [Figure 30-41-40] that does not go through the valve plate.

Align the shoulder of the roller bearing (Item 2) [Figure 30-41-37] and [Figure 30-41-38] with the beveled edge on the valve plate (Item 2) [Figure 30-41-39] and [Figure 30-41-40].

NOTE: Valve plate should sit FLUSH with the case housing when properly installed.

HYDROSTATIC PUMP (SJC) (S/N A5GU20001 - A5GU35031 AND A5GV20001 - A5GV35000) (CONT'D)

Disassembly And Assembly (Cont'd)

Figure 30-41-75

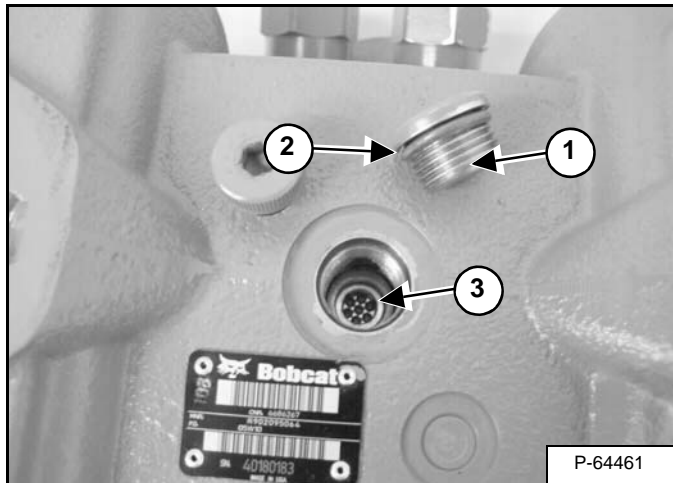

Remove the plug (Item 1) from the top center of the case housing. Replace O-ring (Item 2) [Figure 30-41-75].

Assembly: Tighten plug to 10 N•m (45 ft-lb) torque.

Remove internal screen (Item 3) [Figure 30-41-75].

Assembly: Tighten internal screen to 62 N•m (7.4 ft-lb) torque.

Figure 30-41-76



Ensure screen is clean [Figure 30-41-76].

Figure 30-41-77

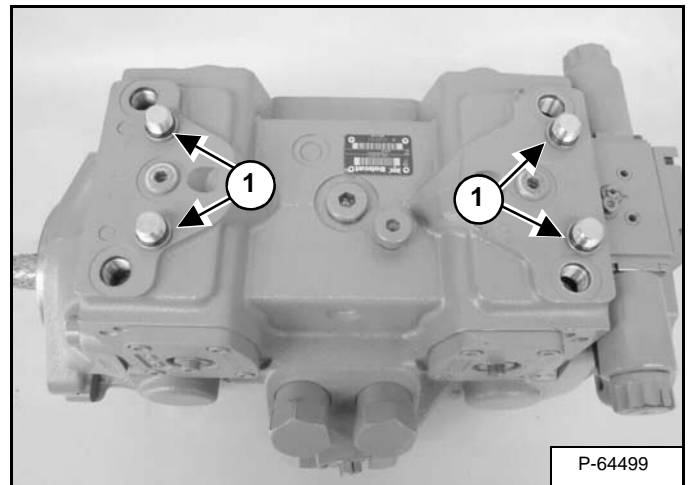

Remove the four control pressure plugs (Item 1) [Figure 30-41-77] at the top of the case housing.

Replace O-rings on plugs.

Assembly: Tighten plugs to 25 N•m (18 ft-lb) torque.

HYDROSTATIC PUMP (SJC) (S/N A5GU35032 & ABOVE AND A5GV35001 & ABOVE) (CONT'D)

Hydraulic Controller Removal And Installation (Cont'd)

Figure 30-42-5

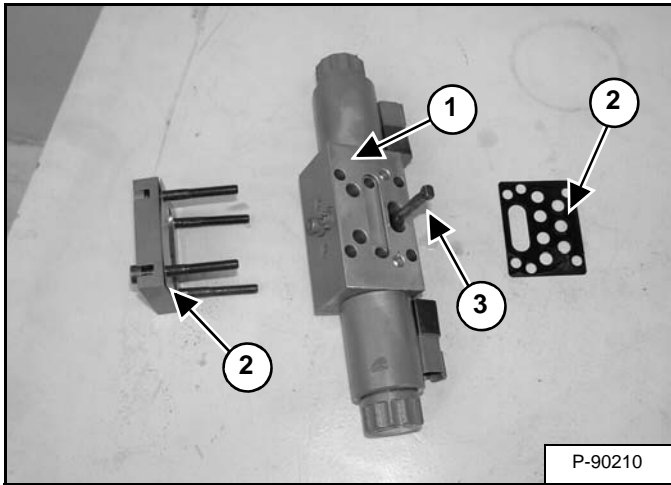

Remove the controller (Item 1) [Figure 30-42-5] from the pump.

Remove the controller gaskets (Item 2) [Figure 30-42-5] from the pump.

Installation:

Figure 30-42-6

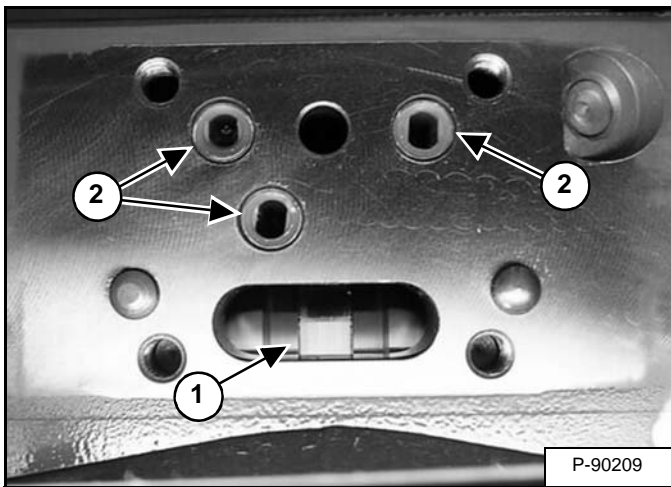

NOTE: Do NOT remove the three screens (Item 2) [Figure 30-42-6] they will be damaged during removal and must be replaced.

Be sure the feedback lever (Item 3) [Figure 30-42-5] is in the center of the servo piston groove (Item 1) [Figure 30-42-6].

Use a small amount of grease on a new gasket and install the gasket on the hydraulic controller (Item 1) [Figure 30-42-5].

Figure 30-42-7

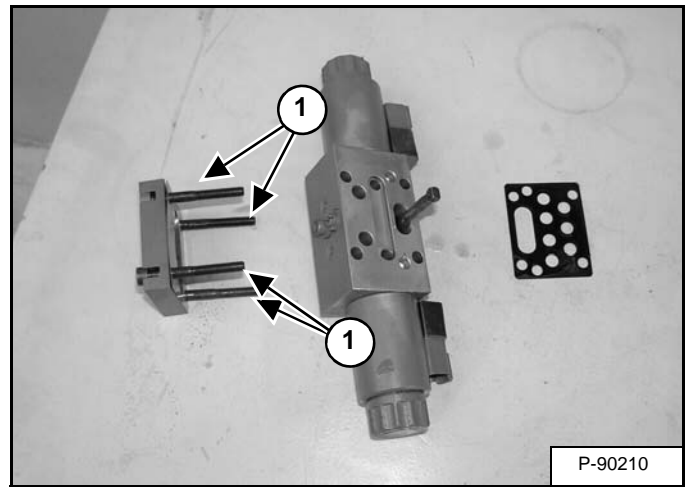

Alternately tighten bolts (Item 1) [Figure 30-42-7] to 10,4 N•m (7.7 ft-lb) torque. Ensure bolts are tightened to specifications.

NOTE: When a hydraulic controller is replaced, the hydrostatic pumps must be calibrated. (See Hydraulic Controller Neutral Adjustment on Page 30-41-25.)

Figure 30-42-8

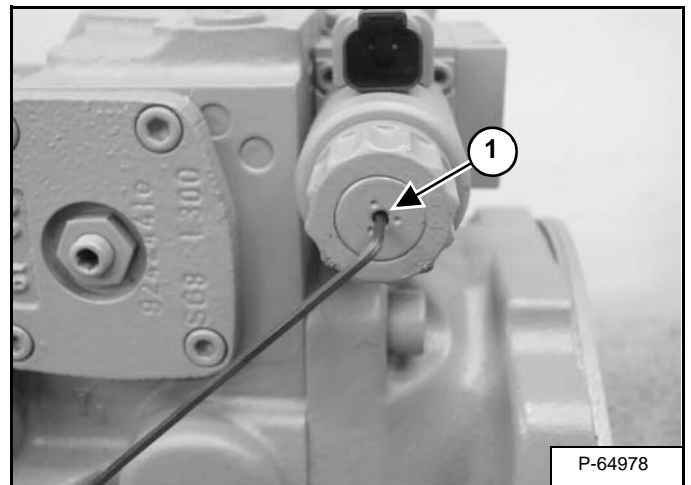

With the engine running and the loader on jackstands: Bleed the trapped air in the controller by loosening the small set screw (Item 1) [Figure 30-42-8] a maximum of 2 turns. Leave the screw loose until oil comes dripping out of the set screw. Tighten set screw to 2 N•m (18 in-lb) torque.

Repeat the bleeding procedure for all of the solenoids.

HYDROSTATIC PUMP (SJC) (S/N A5GU35032 & ABOVE AND A5GV35001 & ABOVE) (CONT'D)

Disassembly And Assembly (Cont'd)

Figure 30-42-33

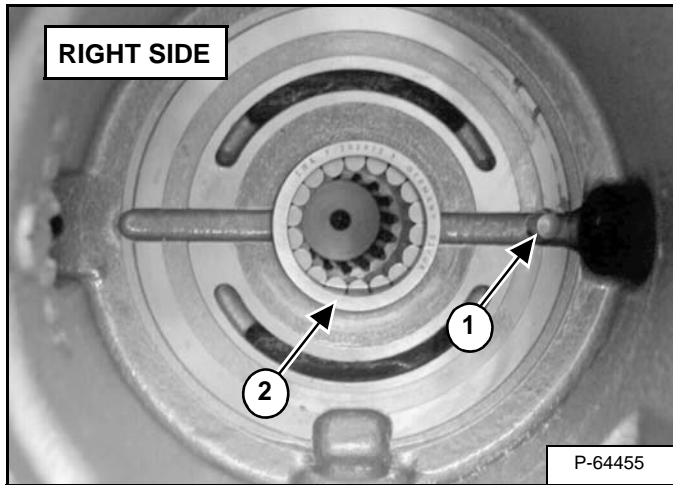

Figure 30-42-34

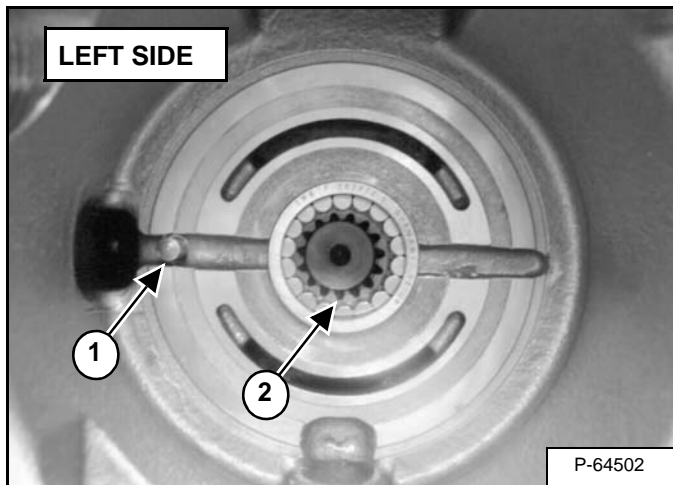

Figure 30-42-35

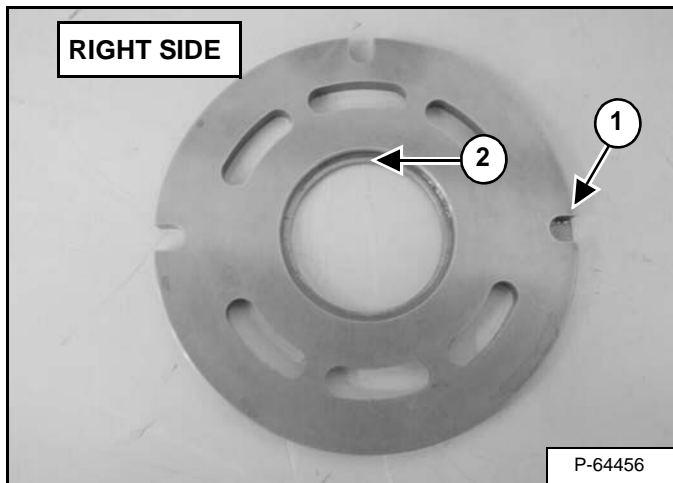
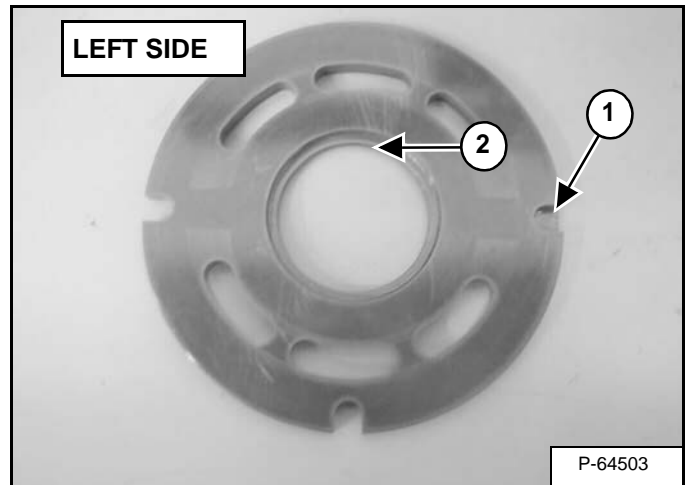

Figure 30-42-36



Assembly: Align the timing pin (Item 1) [Figure 30-42-33] and [Figure 30-42-34] in the case housing with the notch (Item 1) [Figure 30-42-35] and [Figure 30-42-36] that does not go through the valve plate.

Align the shoulder of the roller bearing (Item 2) [Figure 30-42-33] and [Figure 30-42-34] with the beveled edge on the valve plate (Item 2) [Figure 30-42-35] and [Figure 30-42-36].

NOTE: Valve plate should sit FLUSH with the case housing when properly installed.

HYDROSTATIC PUMP (SJC) (S/N A5GU35032 & ABOVE AND A5GV35001 & ABOVE) (CONT'D)

Mechanical Neutral Adjustment (Cont'd)

Figure 30-42-71

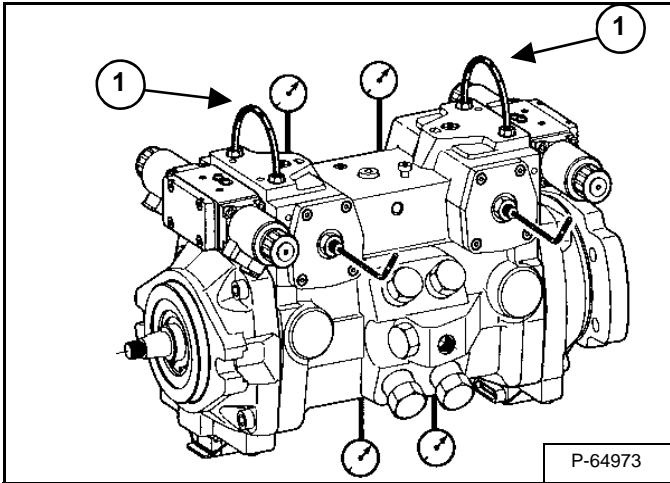

Connect a hydraulic hose (Item 1) [Figure 30-42-71] between port X1 and port X2 on each side of the hydrostatic pump, to equalize the pressures on both ends of the servo pistons.

Figure 30-42-72

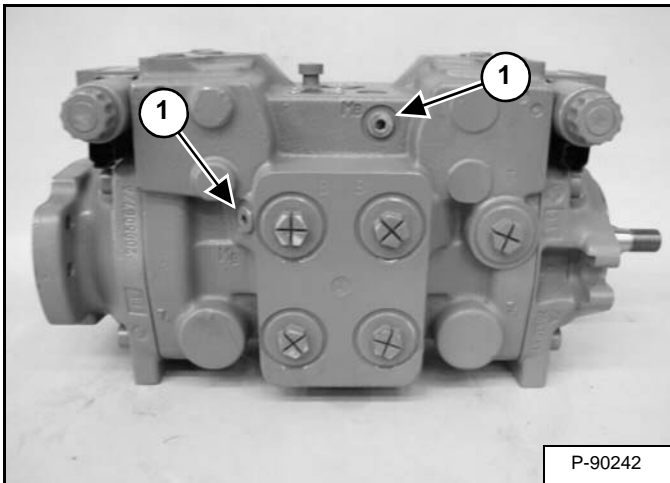

Remove the plugs (Item 1) [Figure 30-42-72] from the MB ports on the front side of the pump, and install 51710,7 kPa (517,1 bar) (7500 psi) pressure gauges.

Figure 30-42-73

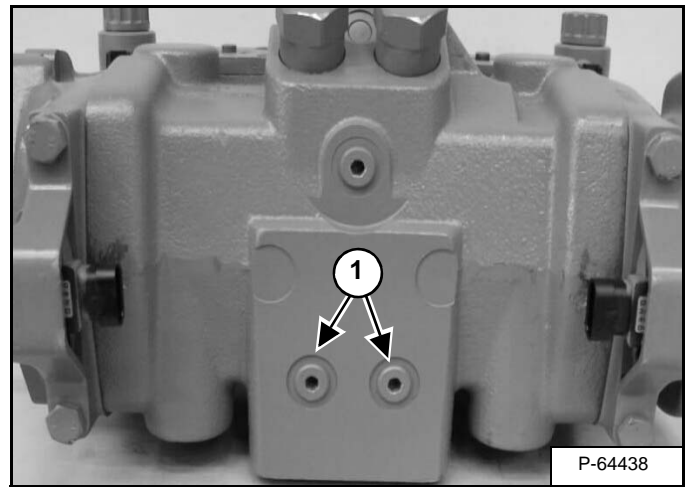

Remove the plugs (Item 1) [Figure 30-42-73] from the MA ports on the bottom of the pump, and install 51710,7 kPa (517,1 bar) (7500 psi) pressure gauges.

Figure 30-42-74

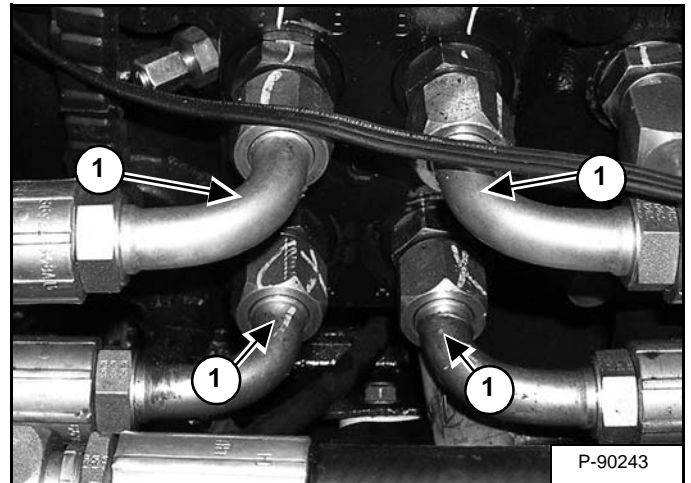

Remove drive hoses from the A and B ports (Item 1) [Figure 30-42-74]. Plug the ports with metal caps. The caps must be able to handle at least 51710,7 kPa (517,1 bar) (7500 psi). Plugging the A and B ports eliminates leakage at the drive motors from causing errors in the pump mechanical neutral setting.

DRIVE BELT (CONT'D)

Tensioner Pulley Tension Spring Removal And Installation

Figure 30-50-14

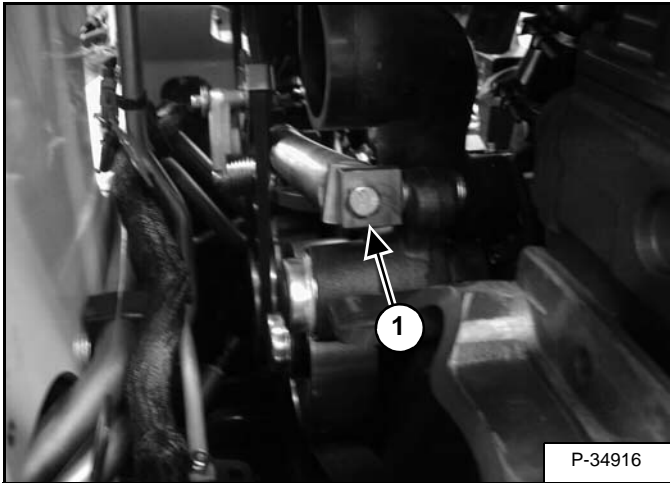

Remove the spring tension bolt (Item 1) [Figure 30-50-14].

Figure 30-50-15

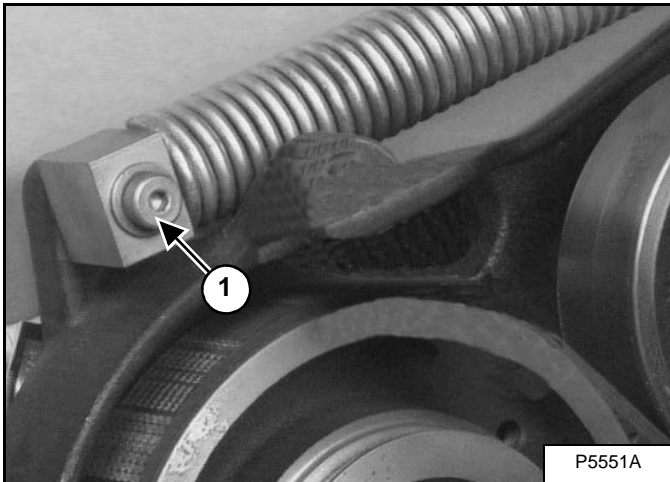

Remove the base end bolt (Item 1) [Figure 30-50-15] from the spring block.

Remove the tension spring from the engine housing.

Tensioner Pulley Tension Spring Disassembly And Assembly

Figure 30-50-16

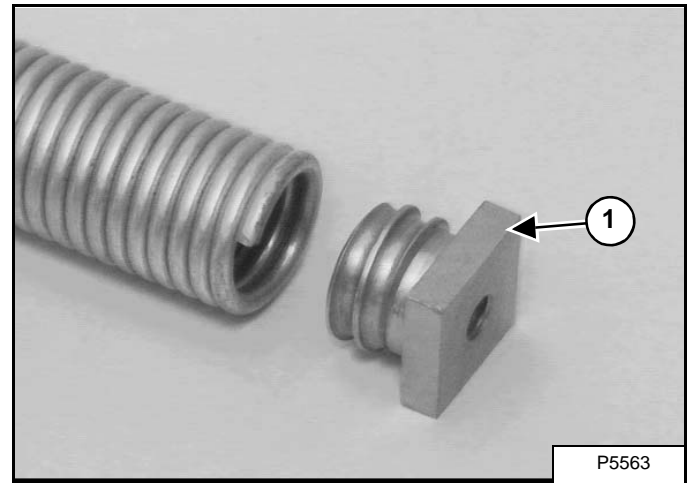

Remove the end block (Item 1) [Figure 30-50-16] (both ends) from the spring.

Check the spring for wear and etc. Replace the spring as needed.

Check the spring end blocks for wear and replace as needed.

**TRACK UNDERCARRIAGE (SOLID-MOUNTED)
(RUBBER TRACK) (S/N A5GU20394 & BELOW AND
A5GV20117 & BELOW)**

Description

Figure 40-20-1

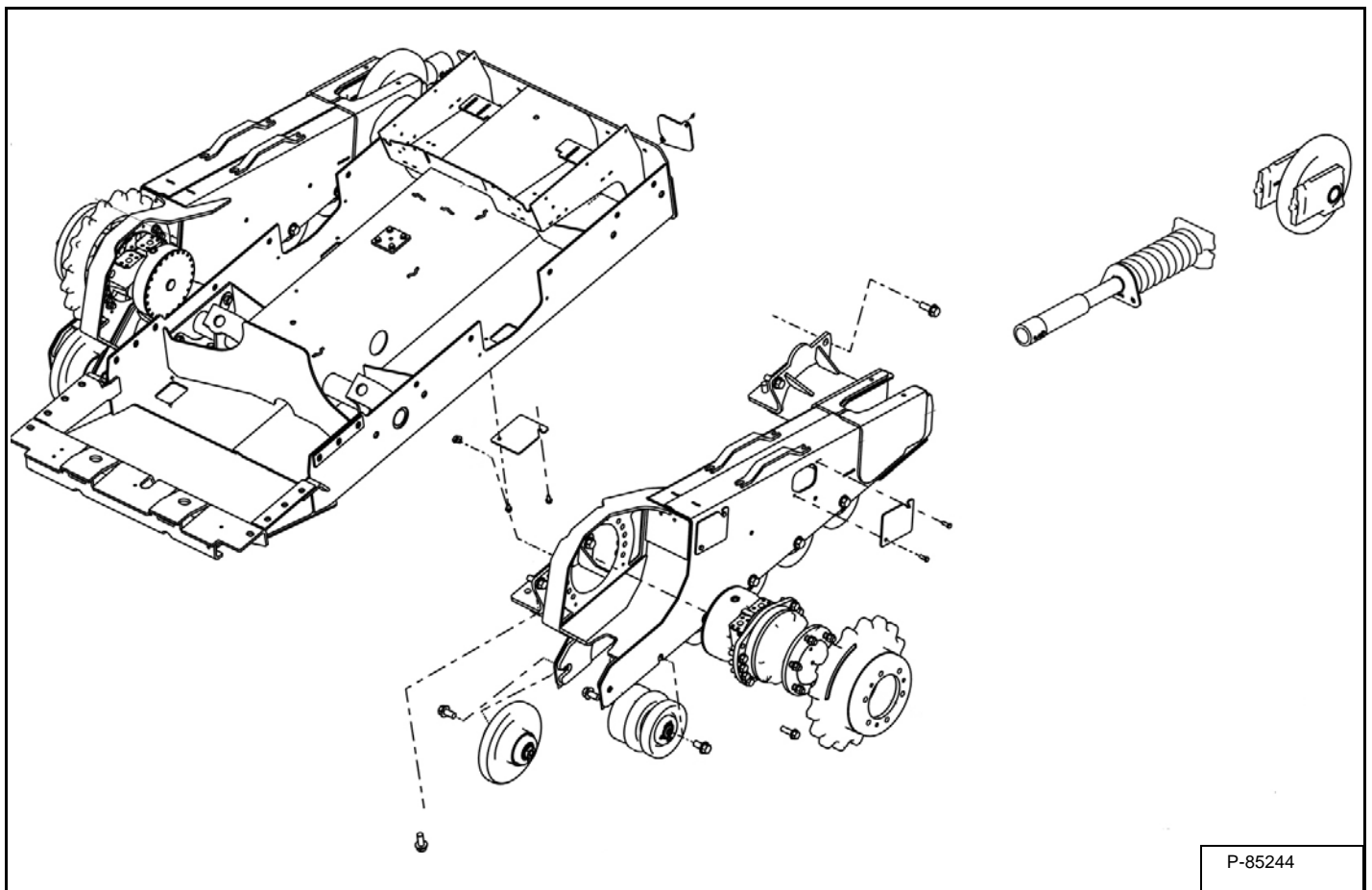

P-85244

The track carriage components consist of front and rear idlers, rollers, the track, track tensioner, the drive sprocket and the track housing [Figure 40-20-1].

**TRACK UNDERCARRIAGE (SOLID-MOUNTED)
(RUBBER TRACK) (S/N A5GU20394 & BELOW AND
A5GV20117 & BELOW) (CONT'D)**

**Track Tensioner Disassembly And Assembly (S/N
A5GU20175 & Below And A5GV20088 & Below)**



P-62574

AVOID INJURY OR DEATH

- Spring loaded components under pressure can cause serious injury or death.
- Do not disassemble the coil spring assembly.

W-2617-1004

Figure 40-20-26

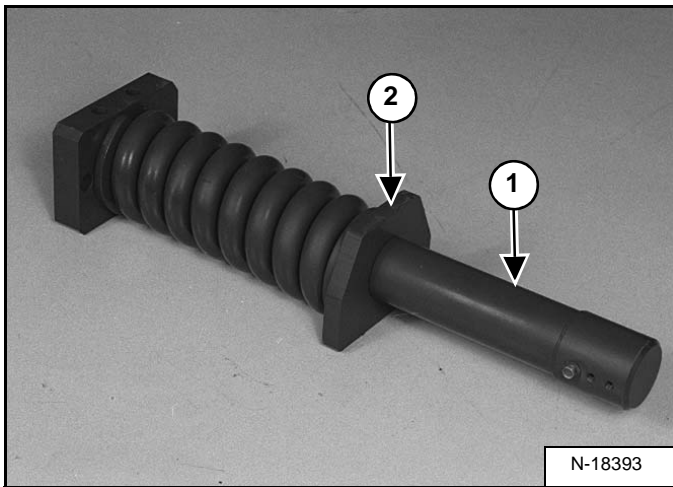

Remove the grease tube (Item 1) [Figure 40-20-26] from the coil spring assembly.

Figure 40-20-27

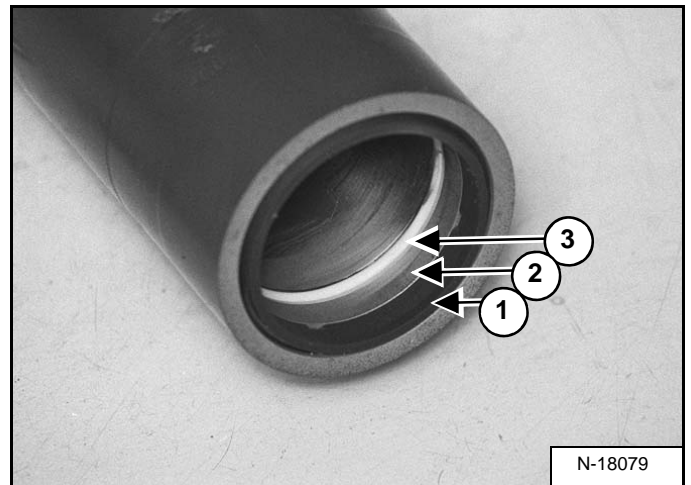

Remove the seal (Item 1), back-up ring (Item 2), and O-ring (Item 3) [Figure 40-20-27] from the grease tube.

Installation: Apply oil to the O-ring, back-up ring and seal before installation.

Installation: Apply grease to area between seal and O-ring before installing.

NOTE: The grease tube (Item 1) must be completely retracted against the coil spring assembly (Item 2) [Figure 40-20-26] before adding grease, to prevent air from being trapped in the grease tube.

Figure 40-20-28

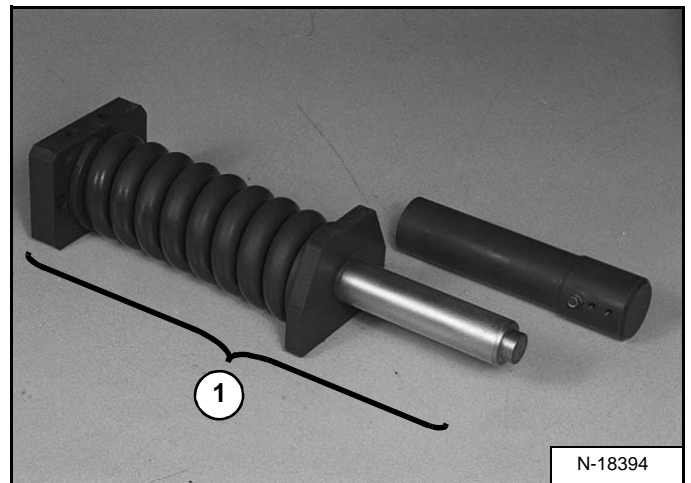

DO NOT DISASSEMBLE OR REPAIR THE COIL SPRING ASSEMBLY. THE COMPRESSION FORCE OF THE SPRING EXCEEDS 6350 kg (14,000 lb).

The coil spring assembly (Item 1) [Figure 40-20-28] is only sold as a complete unit from Bobcat Parts.

**TRACK UNDERCARRIAGE (SOLID-MOUNTED)
(RUBBER TRACK) (S/N A5GU20395 & ABOVE AND
A5GV20118 & ABOVE) (CONT'D)**

Track Removal And Installation (Cont'd)

Figure 40-21-10

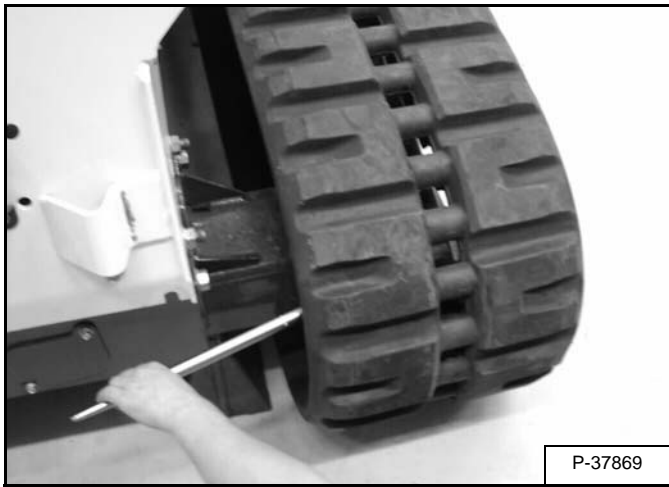

With pry bars, pry the track up and over the front idler **[Figure 40-21-10]**.

Completely remove the track from the front track assembly.

Figure 40-21-11

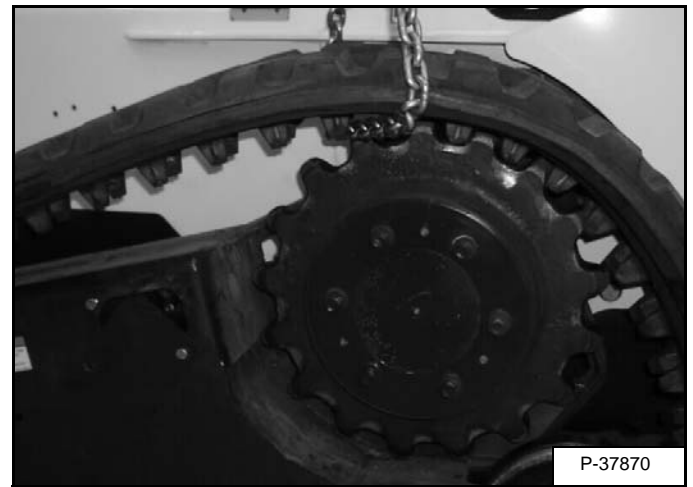

With a chain hoist or arm hoist lift the track clear of the drive sprocket and remove the track from the loader **[Figure 40-21-11]**.

To install the rubber track:

Completely retract the front idler and track tensioner.

Put the track over the rear drive sprocket lugs.

Put the track over the rear idler.

Slide the track under the rollers.

Put the track on the front idler wheel.

Adjust the track to the proper tension. (See Checking Tension on Page 40-21-2.)

NOTE: The grease tube must be completely retracted against the coil spring assembly before adding grease, to prevent air from being trapped in the grease tube.

NOTE: Check the alignment of the grease tube (Item 1) [Figure 40-21-20] before adjusting the track.

TRACK UNDERCARRIAGE (ROLLER SUSPENSION) (RUBBER TRACK)

Description

Figure 40-22-1

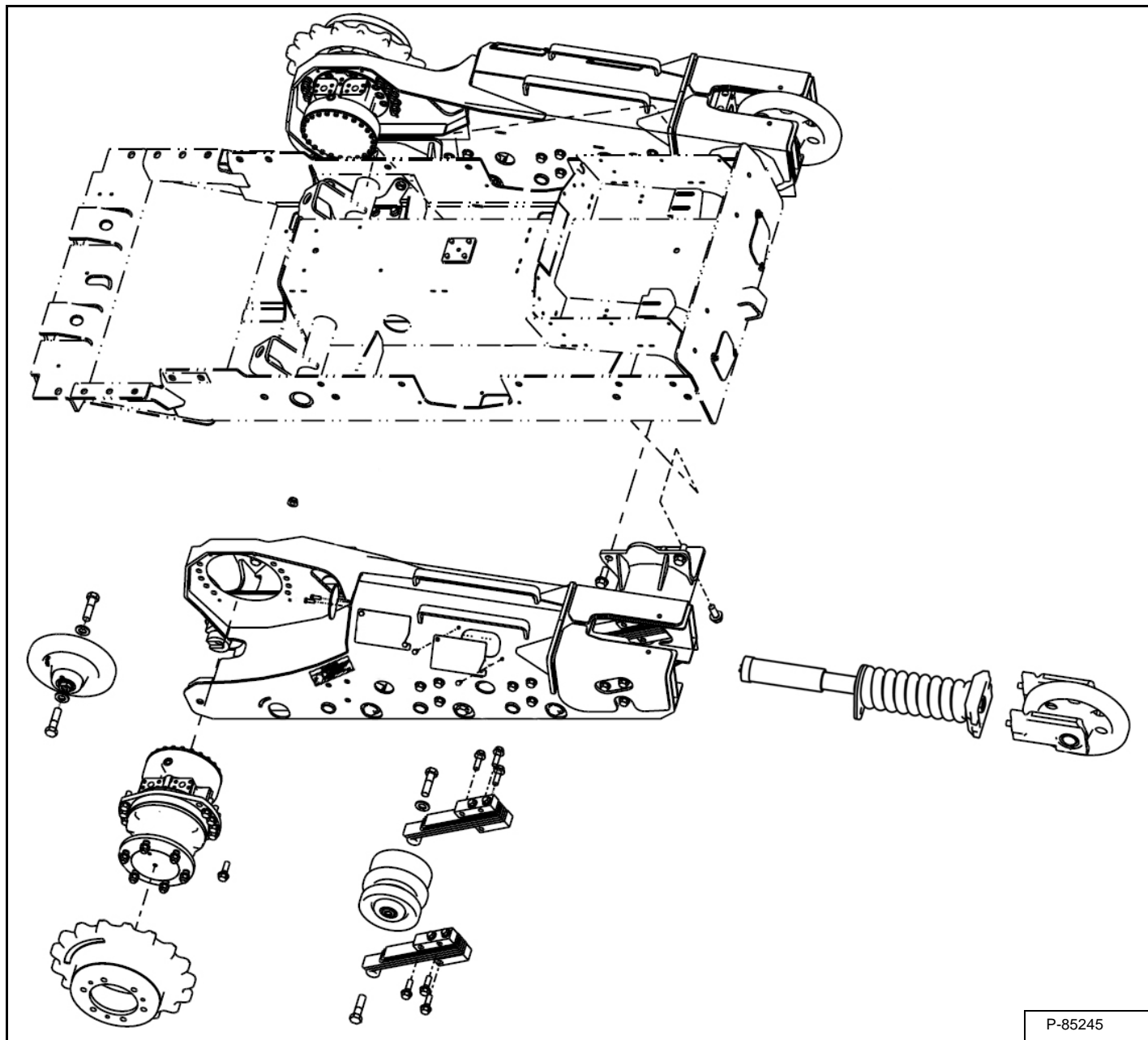

P-85245

The track carriage components consist of front and rear idlers, rollers, leaf springs, the track, track tensioner, the drive sprocket and the track housing [Figure 40-22-1].

**TRACK UNDERCARRIAGE (ROLLER SUSPENSION)
(RUBBER TRACK) (CONT'D)**

**Track Tensioner Disassembly And Assembly (S/N
A5GU20109 & Below And A5GV20057 & Below)**



P-62574

AVOID INJURY OR DEATH

- Spring loaded components under pressure can cause serious injury or death.
- Do not disassemble the coil spring assembly.

W-2617-1004

Figure 40-22-27

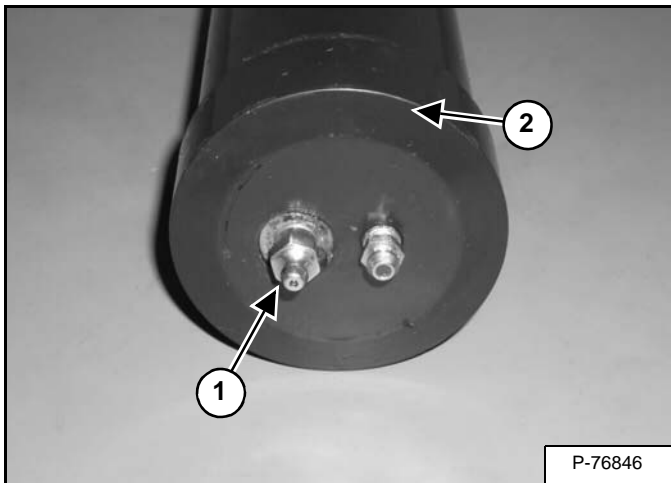

Remove the grease fitting (Item 1). Carefully apply low pressure air to the grease fitting opening until the grease tube (Item 2) [Figure 40-22-27] slowly separates from the coil spring assembly.

Figure 40-22-28

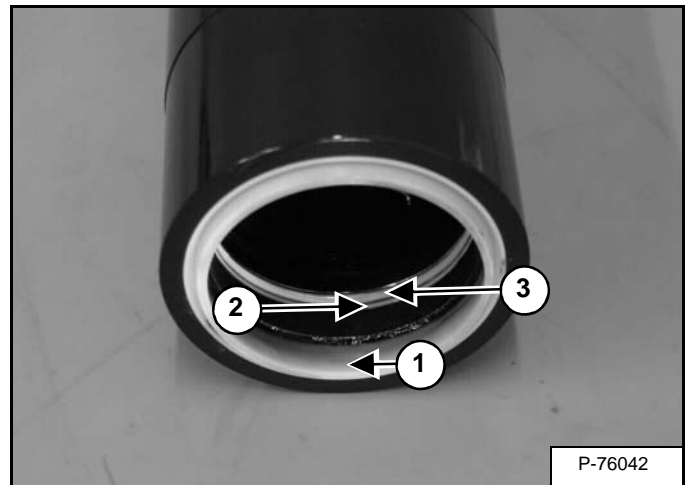

Remove the seal (Item 1), back-up ring (Item 2), and O-ring (Item 3) [Figure 40-22-28] from the grease tube.

Installation: Apply oil to new O-ring, back-up ring and seal before installation.

Installation: Apply grease to area between seal and O-ring before installing.

NOTE: The grease tube must be completely retracted onto the track tensioner before replacing the grease fitting and adding grease, to prevent air from being trapped in the grease tube.

Figure 40-22-29

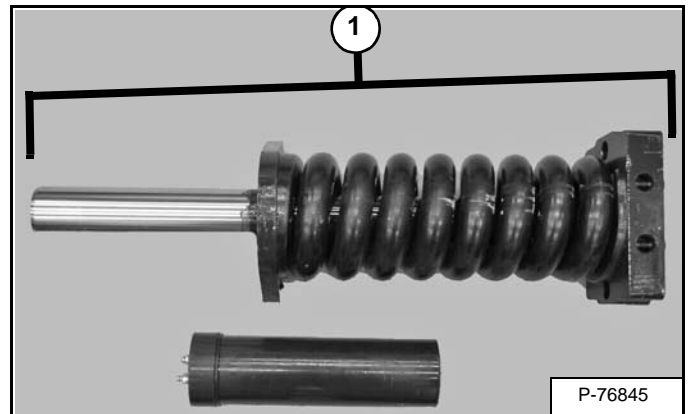

DO NOT DISASSEMBLE OR REPAIR THE COIL SPRING ASSEMBLY. THE COMPRESSION FORCE OF THE SPRING EXCEEDS 6350 kg (14,000 lb).

The coil spring assembly (Item 1) [Figure 40-22-29] is only sold as a complete assembly from Bobcat Parts.

TRACK UNDERCARRIAGE (STEEL TRACK) (CONT'D)

Adjusting Tension

Figure 40-23-5

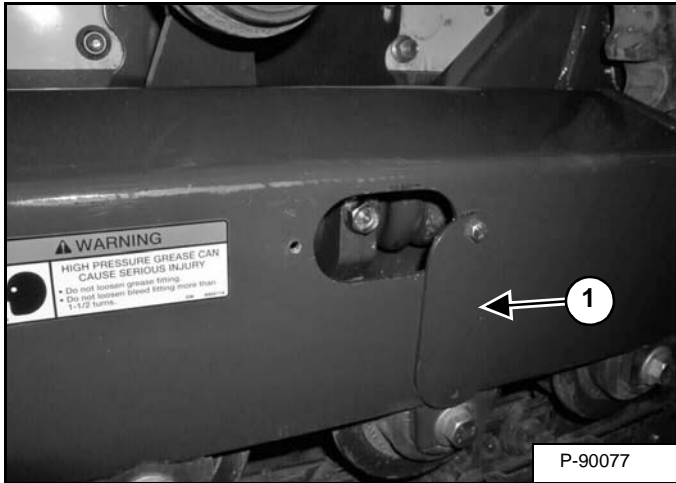

Remove one access cover bolt and loosen the other bolt. Pivot the access cover (Item 1) [Figure 40-23-5] open.

Increase Track Tension

Figure 40-23-6

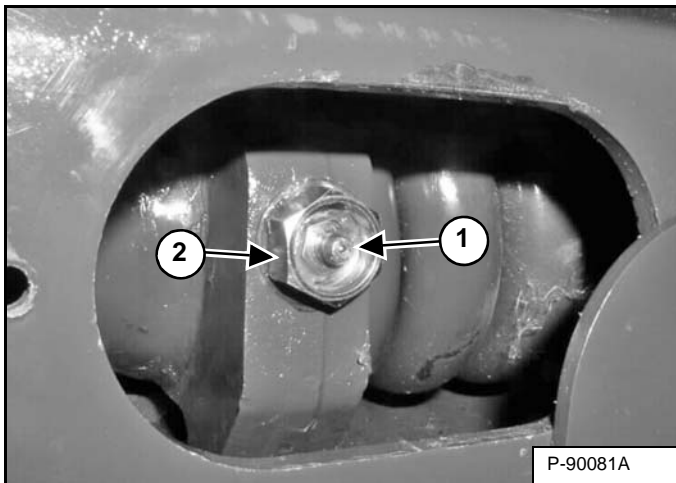

Add grease to the grease fitting (Item 1) [Figure 40-23-6] until the track adjustment is correct [Figure 40-23-3] and [Figure 40-23-4].

NOTE: Do not remove grease fitting unless pressure is released using the bleed fitting. (See Decrease Track Tension on Page 40-23-3.)

NOTE: If replacement is necessary, always replace grease fitting (Item 1) [Figure 40-23-6] with genuine Bobcat Parts. The fitting is a special fitting designed for high pressure.

Decrease Track Tension

! WARNING

HIGH PRESSURE GREASE CAN CAUSE SERIOUS INJURY

- Do not loosen grease fitting.
- Do not loosen bleed fitting more than 1 - 1/2 turns.

W-2781-0109

Pressure must be released from the grease cylinder to decrease track tension.

Loosen the bleed fitting (Item 2) [Figure 40-23-6] between one-quarter and one-half turn using a socket wrench. Grease will flow out around the bleed fitting. Release pressure slowly until the track adjustment is correct [Figure 40-23-3] and [Figure 40-23-4]. Do NOT remove the bleed fitting.

Tighten the bleed fitting.

Pivot the access cover closed and tighten the access cover bolts.

Raise the loader. Remove the jackstands.

Repeat the procedure for the other track.

Dispose of grease in an environmentally safe manner.

**TRACK UNDERCARRIAGE (STEEL TRACK)
(CONT'D)**

Sprocket Removal And Installation

Remove the sprocket. (See Removal And Installation on Page 30-20-2.)

CLICK HERE TO **DOWNLOAD** THE COMPLETE MANUAL

- Thank you very much for reading the preview of the manual.
- You can download the complete manual from: www.heydownloads.com by clicking the link below



- Please note: If there is no response to CLICKING the link, please download this PDF first and then click on it.

CLICK HERE TO **DOWNLOAD** THE COMPLETE MANUAL

TRACK MAINTENANCE (RUBBER TRACK) (CONT'D)

Track Damage Identification (Cont'd)

Cracks And Cuts On The Lug Side Rubber

Figure 40-30-20

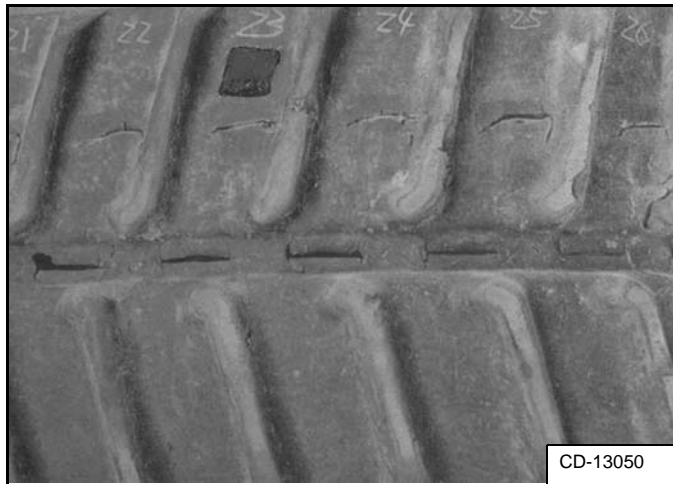

Damage:

Sometimes cracks and cuts on the lug side rubber at the edges of the embedded metals can be observed **[Figure 40-30-20]**.

Replacement:

Basically, no replacement is required unless the cuts on the lug side rubber are discovered all around the edges of the embedded metals, as this will result in a complete cut off.

Figure 40-30-21

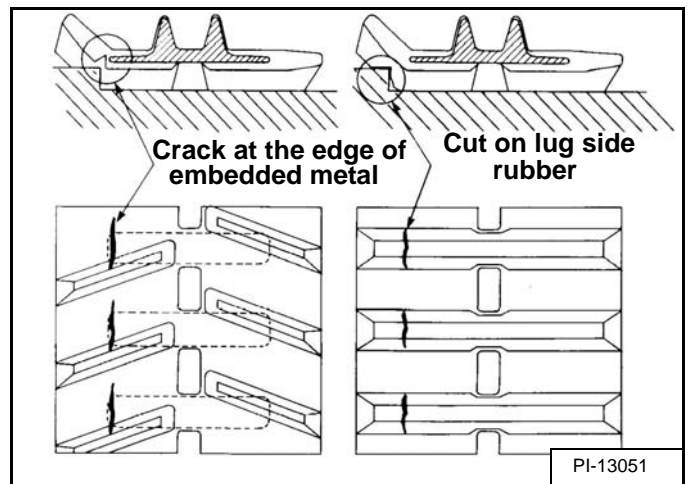

Causes Of The damage:

When rubber tracks drive over sharp projections, intensive stress is applied to the lug side rubber surface, especially at the edges of embedded metals, causing cracks and cuts in the area around the embedded metals **[Figure 40-30-21]**.

Prevention:

To avoid extensive stress applied to the lug root where metals are embedded, machine operators are requested to avoid driving over stumps and ridges.

SEAT BAR (CONT'D)

Compression Spring Disassembly And Assembly

Figure 50-10-9

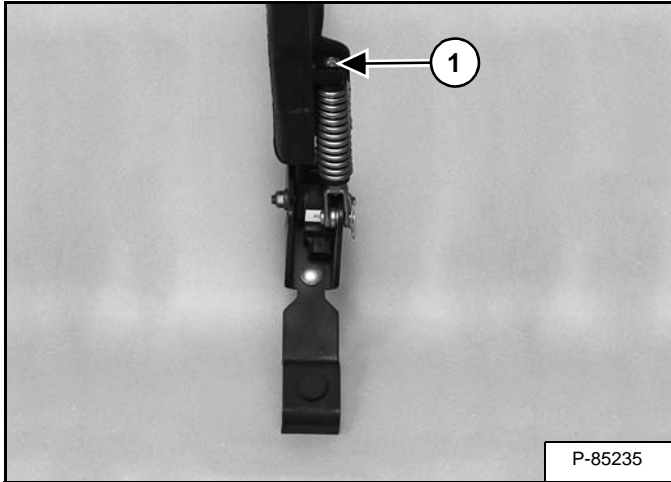

Turn the bolt (Item 1) [Figure 50-10-9] and [Figure 50-10-10] out of the clevis.

Assembly: Apply Loctite® #518 adhesive to the bolt threads. Adjust the compression spring by turning the bolt in past the end of the clevis three turns.

NOTE: For procedures requiring the use of Loctite® #518 adhesive, thoroughly clean and dry affected parts before the application of Loctite® #518.

Figure 50-10-10

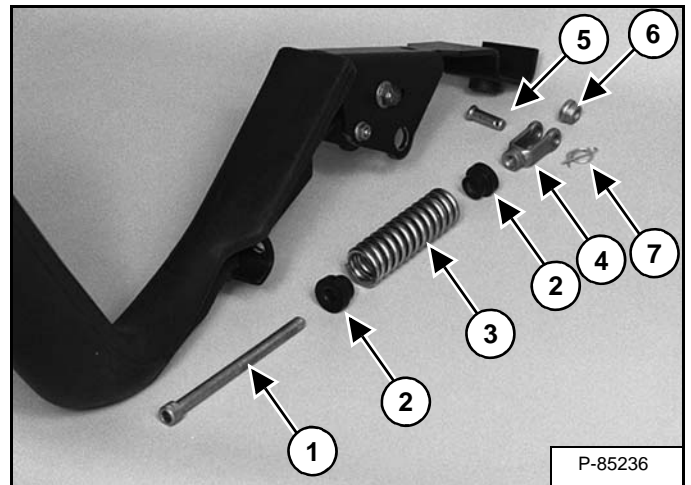

Disassemble and assemble the seat bar compression spring and parts as shown in [Figure 50-10-10].

- Bolt (Item 1)
- Bushings (Items 2)
- Spring (Item 3)
- Clevis (Item 4)
- Retaining Pin (Item 5)
- Bushing (Item 6)
- Cotter Pin (Item 7)

OPERATOR SEAT (SUSPENSION) (CONT'D)

Lower Cushion Removal And Installation

Figure 50-30-7

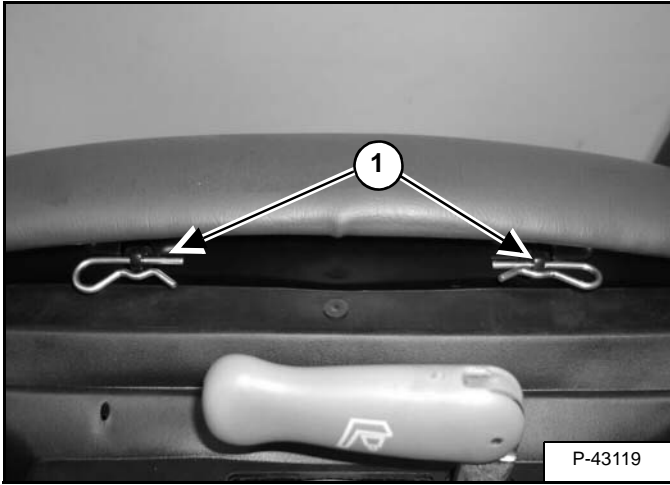

Remove the clips (Item 1) [Figure 50-30-7] from the seat cushion.

Figure 50-30-8

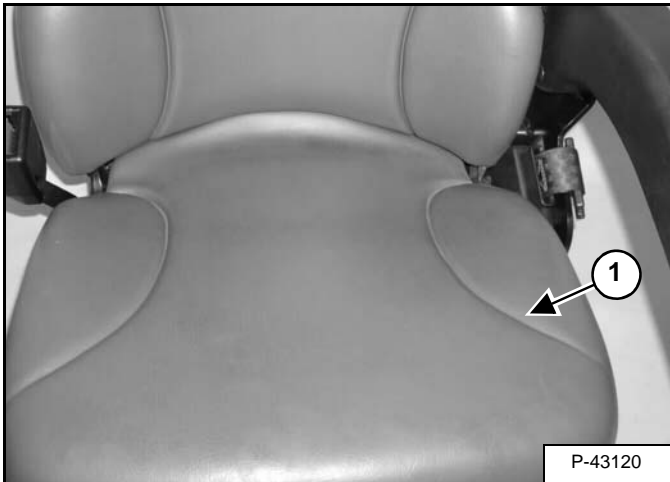

Lift and remove the seat cushion (Item 1) [Figure 50-30-8] from the seat frame.

Figure 50-30-9

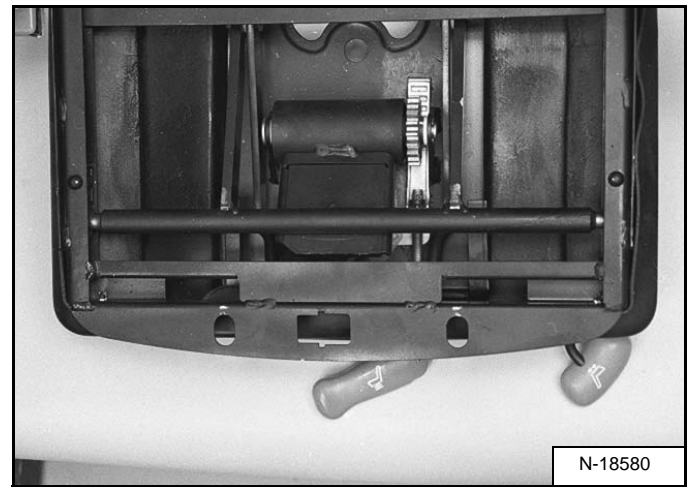

Inspect the seat ride adjustment [Figure 50-30-9].

Reverse the removal procedure to install the operator seat back.

BOB-TACH (POWER)

Description

The Bob-Tach is the section of the loader lift arm that attachments mount to. The Power Bob-Tach option uses two hydraulically operated, spring assisted, locking wedge and lever assemblies to secure the attachment to the Bob-Tach.

The hydraulically operated Power Bob-Tach has a hydraulic cylinder that opens and closes both wedge and lever assemblies by pressing a switch on the front accessory panel. The switch activates the Power Bob-Tach block to allow flow into or out of the hydraulic cylinder connected to the levers on the Bob-Tach.

The Power Bob-Tach block is located on the rear of the gear pump.

The Bob-Tach is located on the front of the loader connected to the loader lift arms.

Removal And Installation

Figure 50-41-1

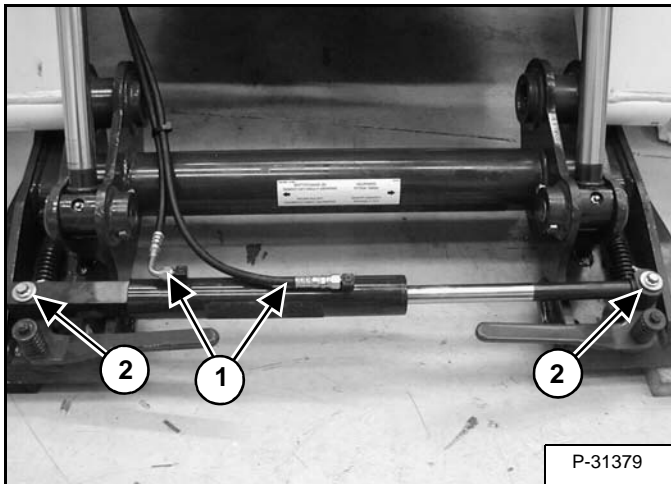

Tilt the Bob-Tach forward, so it is parallel to the floor. Put 2x4 blocks under each side of the Bob-Tach [Figure 50-41-1].

Lower the Bob-Tach onto the blocks.

Mark the hoses (Item 1) [Figure 50-41-1] for correct installation.

Remove the hoses from the cylinder fittings.

Remove the mount bolt (Item 2) [Figure 50-41-1] from the cylinder (both ends).

Remove the cylinder from the Bob-Tach.

Figure 50-41-2

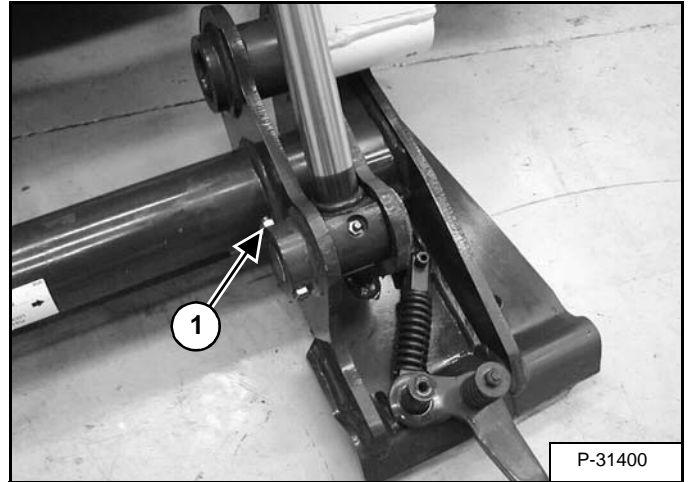

Remove the retainer nut and bolt (Item 1) [Figure 50-41-2] from the tilt cylinder rod end pin (both sides).

Figure 50-41-3

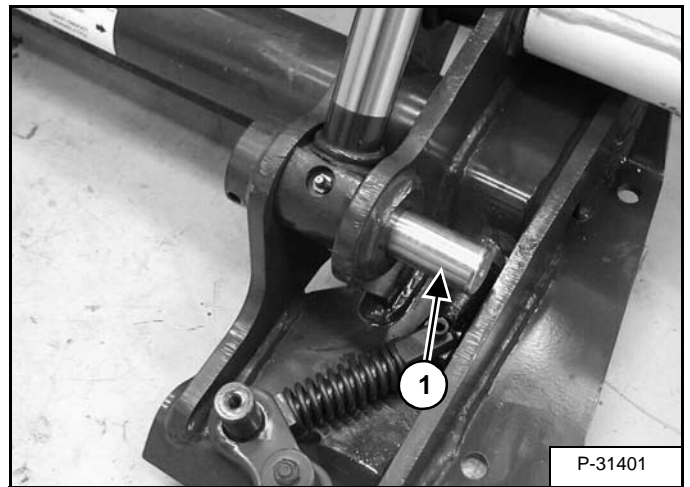

Remove the pivot pin (Item 1) [Figure 50-41-3] from the tilt cylinder rod end (both sides).

Remove the tilt cylinder rod end from the Bob-Tach (both sides).

LIFT ARMS (CONT'D)

Removal And Installation (Cont'd)

Figure 50-50-16

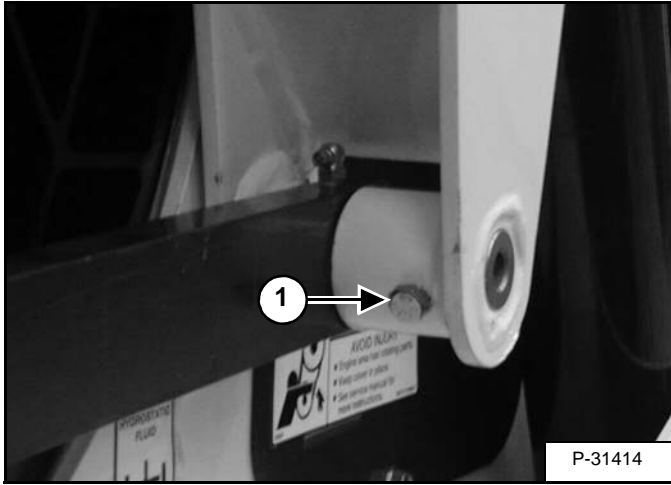

Remove the stabilizer pin retainer bolt and nut (Item 1) [Figure 50-50-16] (both sides).

Figure 50-50-17

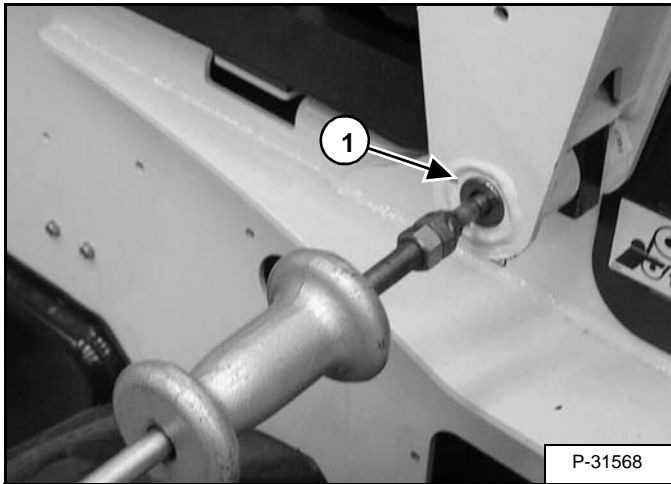

With a slide hammer, remove the rear lift arm stabilizer pin (Item 1) [Figure 50-50-17]. (Both sides.)

Figure 50-50-18

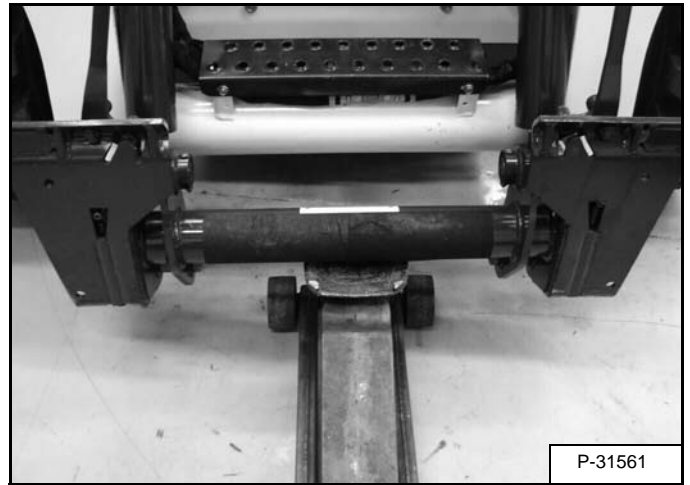

Installation: Support the front of the lift arms with a floor jack.

Installation: Adjusting the lift slings at this point may help to align the stabilizer bar with the lift arm. Use the lifting hoist to align the lift arm with the stabilizer bar.

NOTE: During installation of the lift arm the lift strap on the Bob-Tach may need to be disconnected.

If the Bob-Tach lift strap is disconnected the lift arm link (Item 3) [Figure 50-50-19] needs to be supported to prevent the lift arms from sliding forward.

Figure 50-50-19

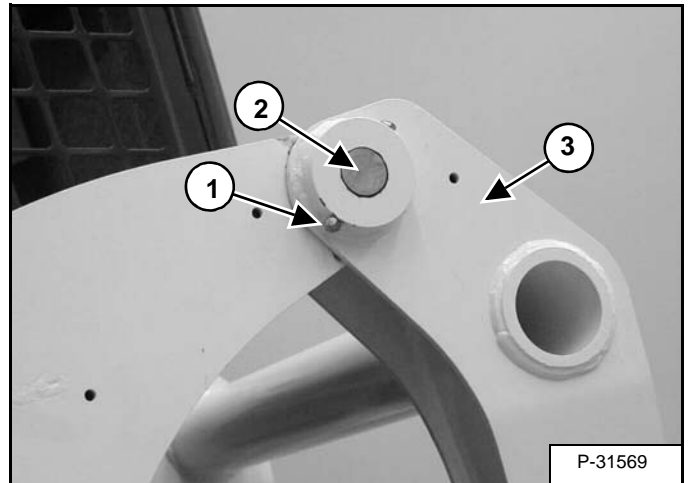

Remove the retainer bolt and nut (Item 1) [Figure 50-50-19] from the lift arm pivot pin (both sides).

Remove the lift arm pivot pin (Item 2) [Figure 50-50-19] (both sides).

Using the chain hoist, remove the lift arms from the loader.

FUEL TANK (CONT'D)

Fuel Level Sender Removal And Installation

Figure 50-80-9

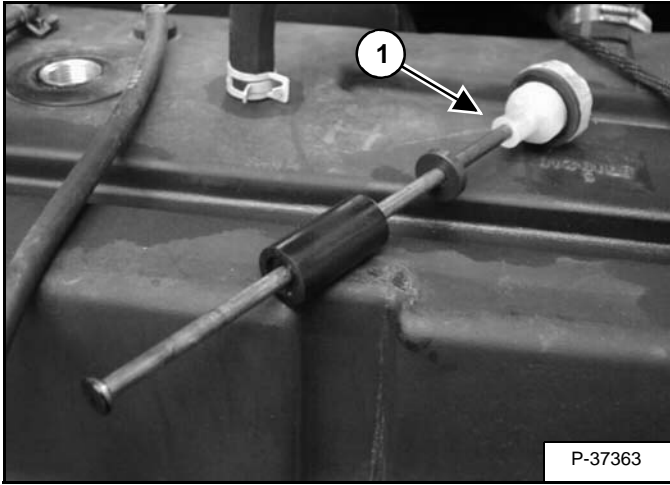

Disconnect the wire harness connector from the fuel level sender.

Loosen the fuel level sender in fuel tank.

Remove the fuel level sender (Item 1) [Figure 50-80-9].

Fuel Fill Screen Removal And Installation

Figure 50-80-10

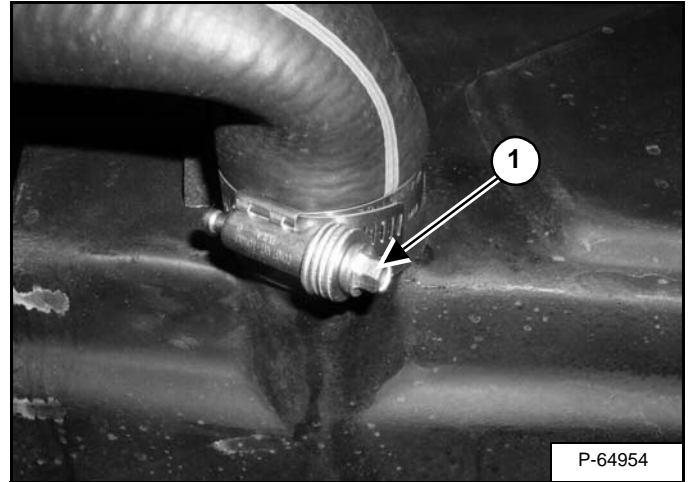

Loosen the hose clamp (Item 1) [Figure 50-80-10] on the tank end of the fuel fill hose.

Figure 50-80-11

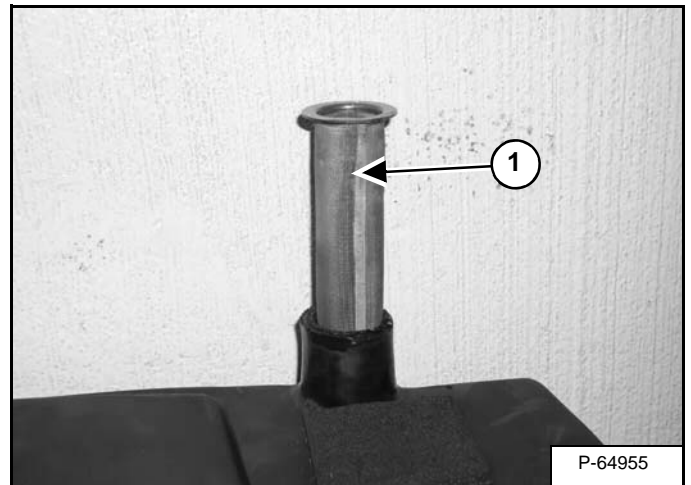

Remove the fuel fill screen (Item 1) [Figure 50-80-11]. Inspect and replace as needed.

CONTROL PANEL (CONT'D)

Removal And Installation (Cont'd)

Figure 50-100-4

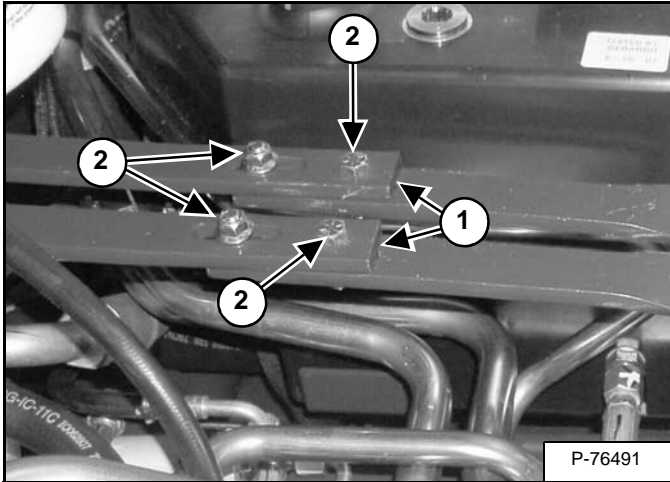

Scribe a mark across the top of the steering linkage bars (Item 1) [Figure 50-100-4] which are connected to the steering shaft on the control panel.

Remove the four steering linkage mounting bolts (Item 2) [Figure 50-100-4].

Installation: Align the marks on the steering linkage bars. Tighten the steering linkage mounting bolts to 47,5 - 54,2 N•m (35 - 40 ft-lb) torque.

Figure 50-100-5

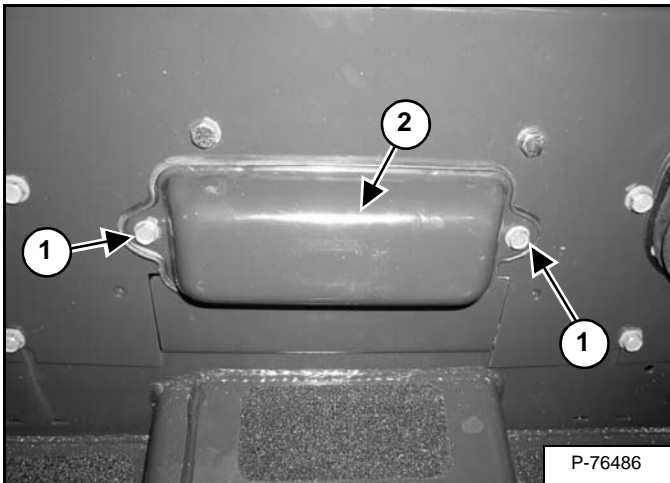

Remove the fuse / relay mounting bolts (Item 1) [Figure 50-100-5].

Remove the fuse / relay cover (Item 2) [Figure 50-100-5].

Figure 50-100-6

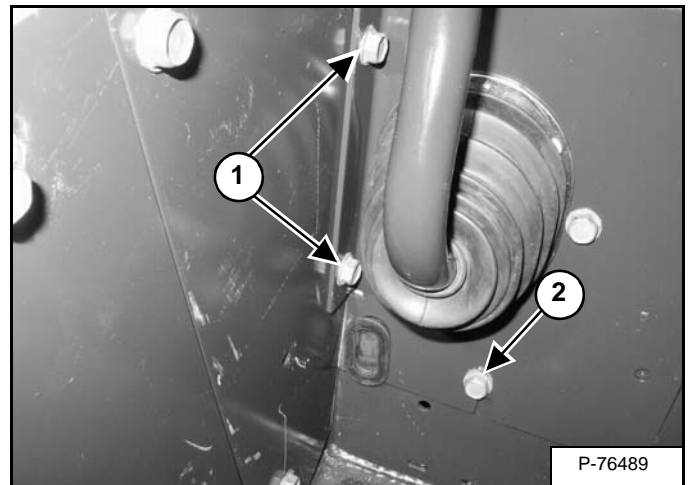
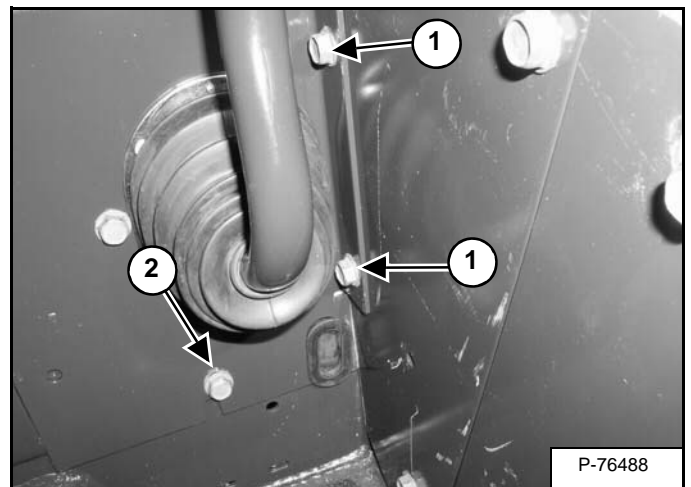

Figure 50-100-7



Remove the control panel mounting bolts (Item 1 and 2) [Figure 50-100-6] and [Figure 50-100-7] from both sides of the control panel.

Installation: Tighten the control panel mounting bolts to 27 N•m (20 ft-lb) torque.

NOTE: Install the bottom bolts (Item 2) [Figure 50-100-6] and [Figure 50-100-7] through the hole in the control panel, do not install them in the slotted area.

CONTROL PANEL (CONT'D)

Linkage Neutral (Adjusting) (Cont'd)

Start the neutral adjustment procedure with the left pump first and complete the neutral adjustment for the left pump before adjusting the right pump.

Figure 50-100-31

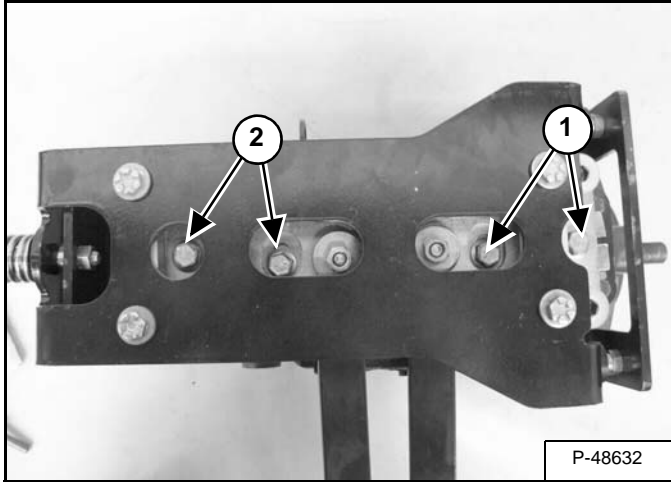

Loosen the left pump pintle adjustment lock bolts (Item 1). (The right pump pintle adjustment lock bolts are (Item 2) [Figure 50-100-31].) Loosen the bolts enough to allow free movement between the pintle arm and the pintle base.

NOTE: If the bolts are too loose or too tight, the neutral adjustment may be affected.

Figure 50-100-32

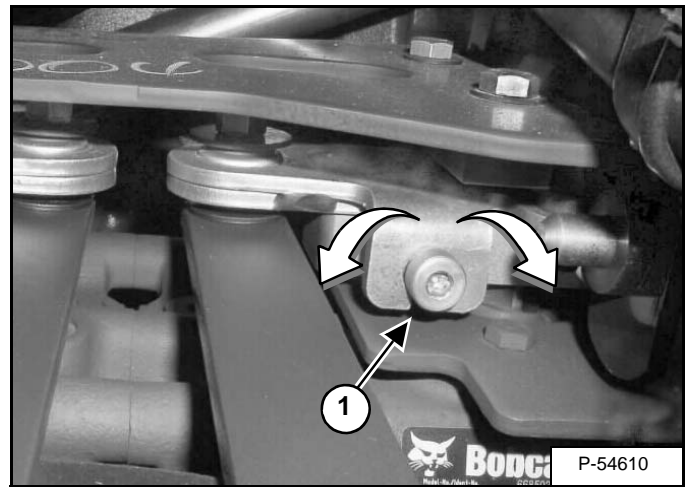

Move the engine speed control to high idle.

NOTE: The neutral range (dead-band) will vary between the hydrostatic pumps.

NOTE: This procedure is shown for neutral adjustment on the left side of the loader. The procedure is the same for the right side neutral adjustment.

Turn the adjustment screw (Item 1) [Figure 50-100-32] counterclockwise until forward creep is seen.

Turn the adjustment screw (Item 1) [Figure 50-100-32] counterclockwise to a point between forward and reverse where there is zero creep.

Stroke the left steering lever to forward and allow the lever to return to neutral. Stroke the left steering lever to reverse and allow the lever to return to neutral. Check that there is zero creep when the lever returns from either direction, on the left side. Turn the adjustment screw (if necessary) until zero creep is obtained.

CONTROL HANDLE / LEVER

Description

The control handles / levers are used to control the forward and reverse travel.

The control handles / levers are mounted to the control panel.

Lever Removal And Installation

Figure 50-110-1

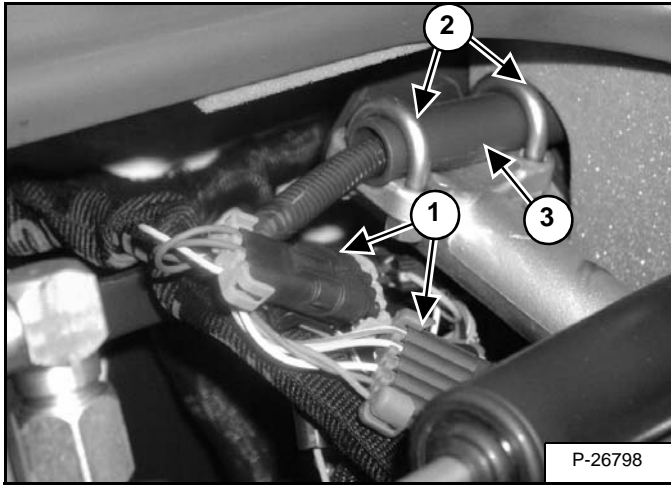

Disconnect the electrical connectors (Item 1) [Figure 50-110-1] from the control lever.

Remove the nuts from the two U-bolts (Item 2) [Figure 50-110-1] used to mount the control lever.

Remove the U-bolts from the control lever mount.

Remove the control lever (Item 3) [Figure 50-110-1] by sliding the lever through the rubber boot (Item 1) [Figure 50-110-2] on the front of the control panel.

Installation: Tighten the U-bolts so the lever can not be moved either right or left when seated in the operator seat. Be sure the control lever does not interfere with the operator cab when lowering or raising the cab.

Boot Removal And Installation

Figure 50-110-2

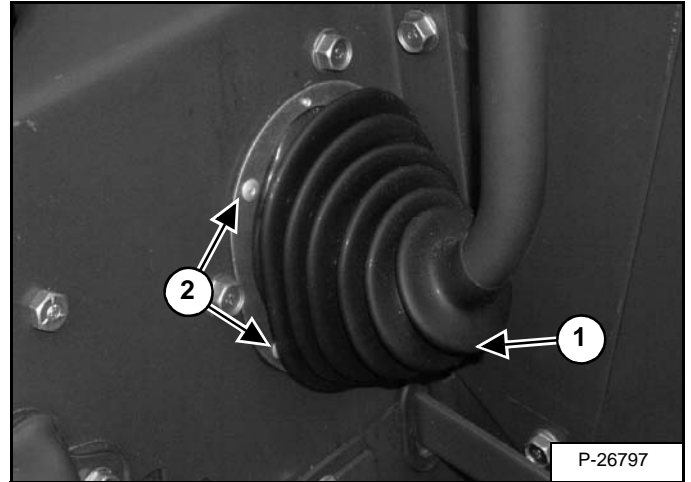

To replace the rubber boot (Item 1) [Figure 50-110-2] on the control panel, remove the steering lever. (See above procedure.)

Drill out the four rivets (Item 2) [Figure 50-110-2] located on the flange of the rubber boot and remove the old boot.

Install the new boot and reinstall the steering lever.

CONTROL HANDLE / LEVER (SJC)

Description

The control panel has two electronic handles that control the steering, lift, and tilt functions. There is no mechanical linkages connecting to the hydrostatic pumps or the control valve.

The control panel is connected to the lower mainframe and wraps around and underneath the operator seat.

WINDOW (REAR)

Removal



AVOID INJURY OR DEATH

Wear safety glasses to prevent eye injury when any of the following conditions exist:

- When fluids are under pressure.
- Flying debris or loose material is present.
- Engine is running.
- Tools are being used.

W-2019-0907

Figure 50-130-1

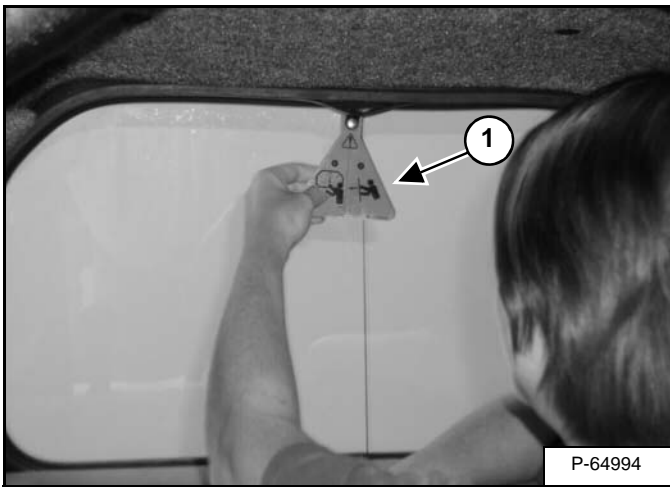

Pull on the tag (Item 1) [Figure 50-130-1] on the rear window to remove the rubber cord.

Using gloves, push the rear window out the rear of the operator cab.

NOTE: If rear window is broken, remove all glass fragments from the rubber molding before installing a new window.

Installation (Split Molding)

Clean the area before installing the rubber molding.

Figure 50-130-2

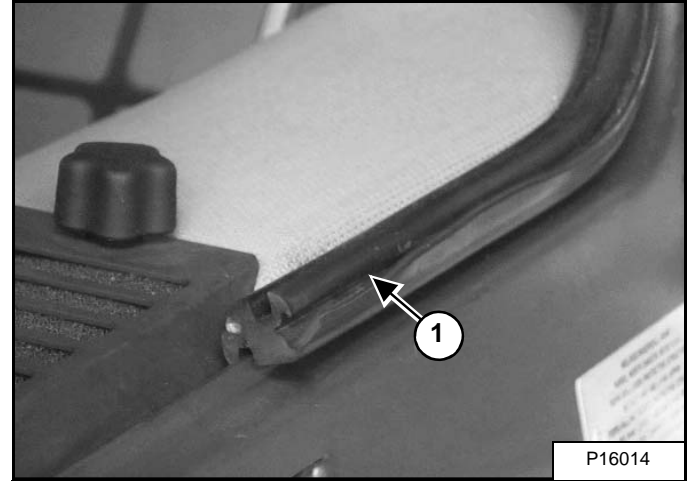

Install the rubber molding (Item 1) [Figure 50-130-2] around the edge of the rear opening in the operator cab.

If replacing the rubber molding (Item 1) [Figure 50-130-2] cut off the excess molding.

Figure 50-130-3

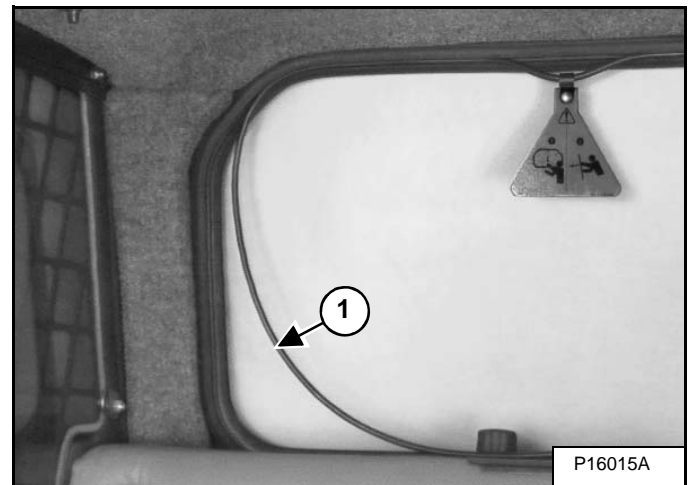

Apply liquid soap on the rubber cord to make installation easier. Install the rubber cord (Item 1) [Figure 50-130-3] into the molding on the inside of the operator cab.

Install the safety tag in the top center of the cord.

WINDOW (CAB DOOR) (CONT'D)

Installation (Standard Window) (Cont'd)

Figure 50-133-8

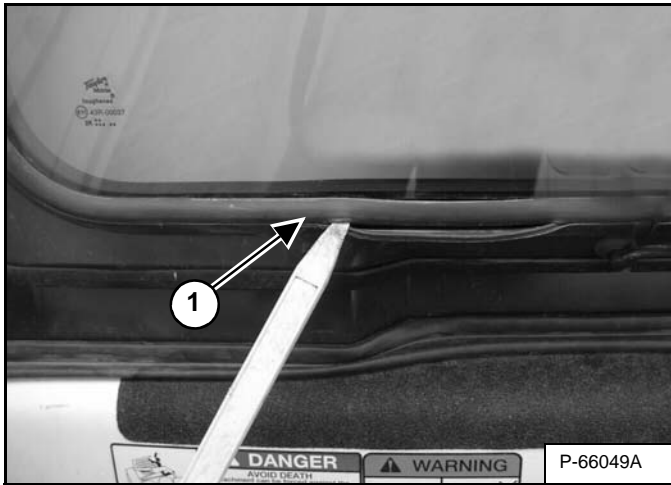

Use the plastic stick (Item 1) [Figure 50-133-8] to position the locking tab into the groove to secure the window in the molding.

Tapping the window corners will help seat the window in the molding.

Figure 50-133-9

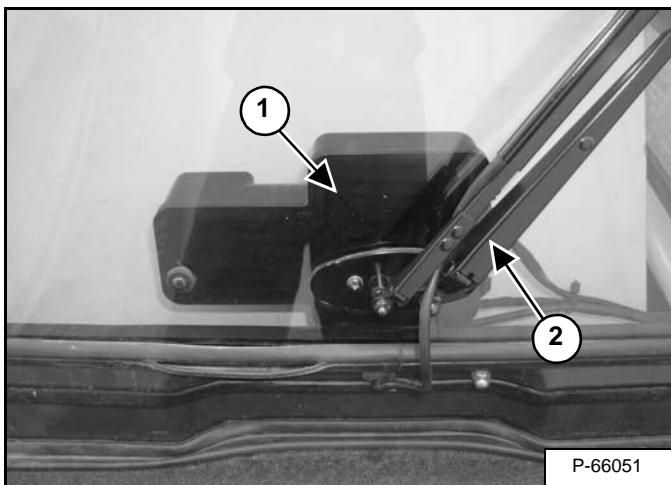

Install the wiper motor (Item 1) and wiper arm assembly (Item 2) [Figure 50-133-9].

ELECTRICAL SYSTEM & ANALYSIS (CONT'D)

SPEED SENSORS (SJC)	60-80-1
Description	60-80-1
Removal And Installation	60-80-3
Testing	60-80-1
STARTER	60-40-1
Parts Identification	60-40-3
Removal And Installation	60-40-2
Testing	60-40-1
STEERING DRIFT COMPENSATION	60-161-1
Description	60-161-1
Operation	60-161-1
TRACTION LOCK	60-120-1
Description	60-120-1
Inspecting	60-120-3
Troubleshooting	60-120-2

TIGHTEN ALL HARDWARE PER SIZE TO GRADE 5 TORQUE (SEE STANDARD TORQUE SPECIFICATIONS FOR BOLTS, SECTION SPEC-01) UNLESS OTHERWISE SPECIFIED.

SPECIFICATIONS SUBJECT TO CHANGE WITHOUT NOTICE AND STANDARD ITEMS MAY VARY.

ELECTRICAL SYSTEM INFORMATION (CONT'D)

Glossary Of Electrical Symbols (Cont'd)

SYMBOL

DESCRIPTION

SENDERS AND SENSORS

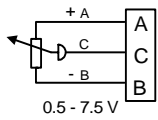

PRESSURE SENDER - Provides a variable voltage proportional to pressure. (Sender voltage rating is listed to show volts at high and low setting.)

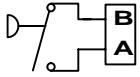

PRESSURE SWITCH - Switch opens or closes at a predetermined pressure to active a function or to turn on a warning light. (Switch is shown in the open position.)

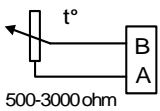

TEMPERATURE SENDER - Provides a variable resistance (ohm) signal proportional to temperature. (Sender ohm rating is listed to show ohms at high and low setting.)

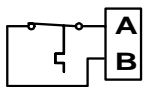

TEMPERATURE SWITCH - The switch opens or closes at a predetermined temperature to active a function or to turn on a warning light. (Switch is shown in the closed position.)

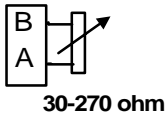

FUEL SENDER - Provides a variable resistance, based on the fuel level in the tank. (Sender ohm rating is listed to show ohms at full and empty setting.)

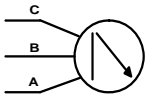

HALL EFFECT SENSOR - Detects linear or rotary position and provides a proportional variable voltage.

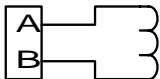

SPEED SENSOR - magnetic pickup - detects rpm.

BATTERY (CONT'D)

Using A Booster Battery (Jump Starting)

If it is necessary to use a booster battery to start the engine, BE CAREFUL! There must be one person in the operator's seat and one person to connect and disconnect the battery cables.

The key switch must be OFF or the STOP button must be pressed. The booster battery must be 12 volt.

WARNING

BATTERY GAS CAN EXPLODE AND CAUSE SERIOUS INJURY OR DEATH

Keep arcs, sparks, flames and lighted tobacco away from batteries. When *jumping* from booster battery make final connection (negative) at machine frame.

Do not jump start or charge a frozen or damaged battery. Warm battery to 16°C (60°F) before connecting to a charger. Unplug charger before connecting or disconnecting cables to battery. Never lean over battery while boosting, testing or charging.

W-2066-0910

Figure 60-20-4

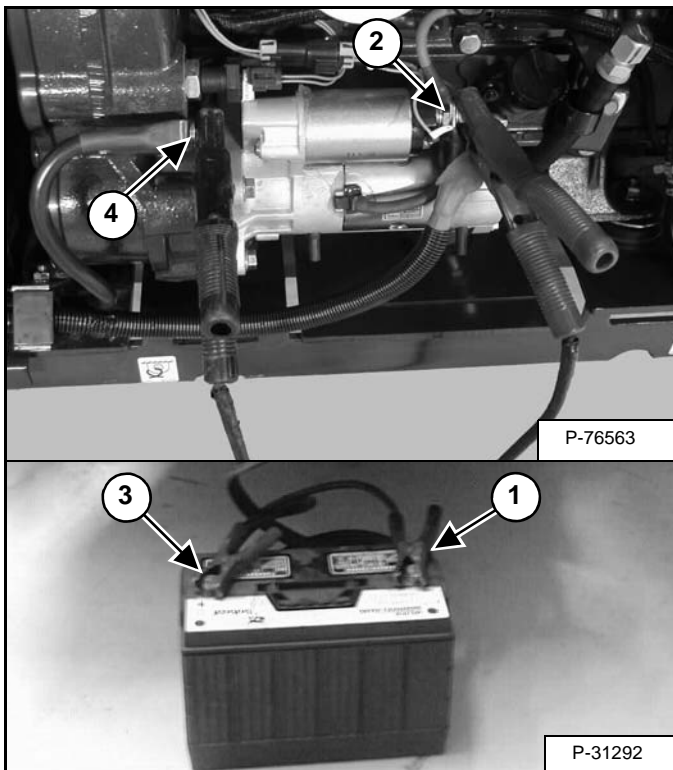

Connect the end of the first cable (Item 1) [Figure 60-20-4] to the positive (+) terminal of the booster battery. Connect the other end of the same cable (Item 2) [Figure 60-20-4] to the positive terminal on the loader starter.

Connect the end of the second cable (Item 3) [Figure 60-20-4] to the negative terminal of the booster battery. Connect the other end of the same cable (Item 4) [Figure 60-20-4] to the engine.

Keep cables away from moving parts. Start the engine.

After the engine has started, remove the ground (-) cable (Item 4) [Figure 60-20-4] first. Remove the cable from the positive terminal (Item 2) [Figure 60-20-4].

IMPORTANT

Damage to the alternator can occur if:

- Engine is operated with battery cables disconnected.
- Battery cables are connected when using a fast charger or when welding on the loader. (Remove both cables from the battery.)
- Extra battery cables (booster cables) are connected wrong.

I-2023-1285

STARTER (CONT'D)

Parts Identification

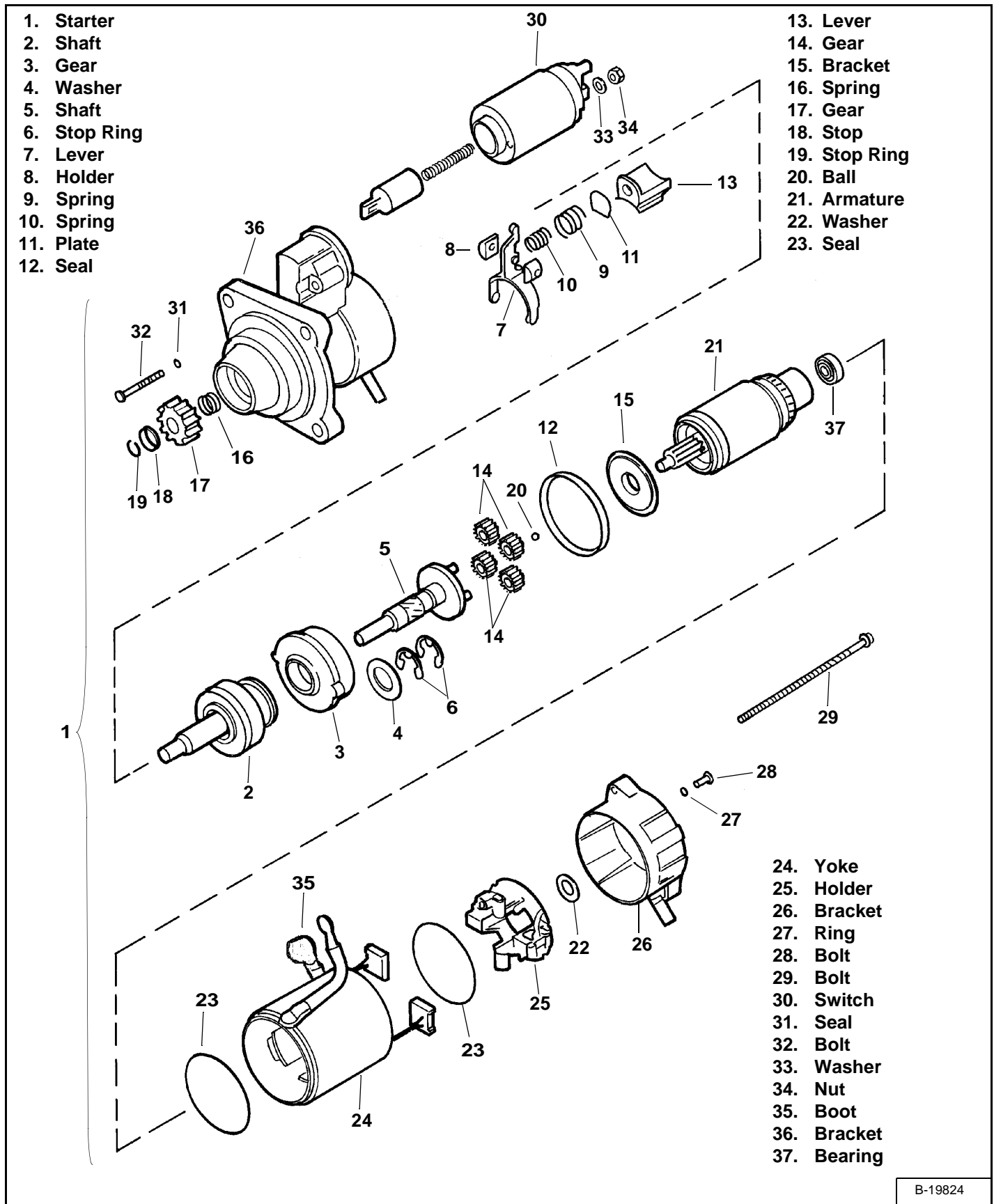

B-19824

INSTRUMENT PANELS (CONT'D)

Alarm Removal And Installation

Remove the left side instrument panel. (See Removal And Installation (Left And Right) on Page 60-50-6.)

Figure 60-50-19

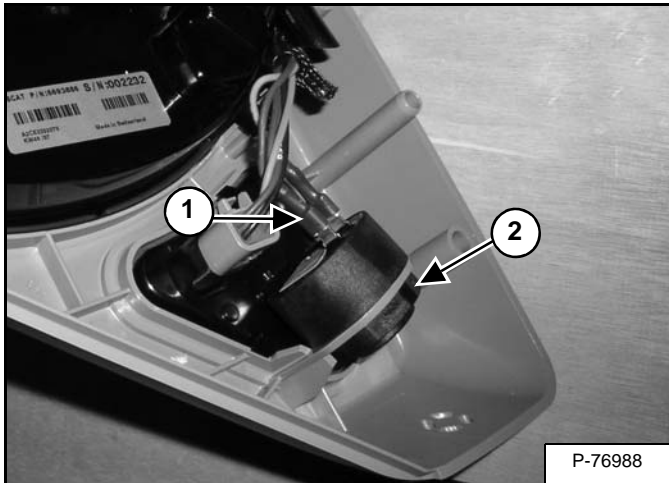

Remove the two wires (Item 1) [Figure 60-50-19] from the loader alarm.

Remove the retaining nut (Item 2) [Figure 60-50-19] from the loader alarm.

Remove the alarm from the loader instrument panel.

BOBCAT CONTROLLER (GATEWAY AND AUXILIARY) (CONT'D)

Connector Identification (Cont'd)

J2B

PIN	WIRE NUMBER	COLOR	DESCRIPTION
1	OPEN	NA	NA
2	1180	RED/WHT	COMPUTER FUSE POWER OUT
3	1150	RED/WHT	COMPUTER FUSE POWER OUT
4	4450	LGN	DIVERTER SOLENOID SIGNAL
5	4440	LGN	REAR BASE SIGNAL
6	4480	LGN	FRONT / REAR AUXILIARY SIGNAL
7	4430	LGN	REAR ROD SIGNAL
8	9220	PURPLE	CAN LO 0
9	9120	PUR/WHT	CAN HI 0
10	OPEN	NA	NA
11	OPEN	NA	NA
12	OPEN	NA	NA
13	4340	LGN	FRONT BASE SOLENOID SIGNAL
14	OPEN	NA	NA
15	2550	BLACK	AUXILIARY CONTROLLER GROUND
16	2540	BLACK	AUXILIARY CONTROLLER GROUND
17	4310	LBL	RIGHT HANDLE PWM LOW
18	4320	LBL	RIGHT HANDLE PWM SIGNAL
19	4330	LGN	FRONT ROD SOLENOID SIGNAL
20	OPEN	NA	NA
21	4920	LGN	RIGHT HANDLE TRIGGER RETURN
22	1560	RNG	SWITCHED INPUT POWER
23	4300	LGN	RIGHT HANDLE PWM HIGH
24	OPEN	NA	NA
25	OPEN	NA	NA
26	4460	LGN	HIGH FLOW SOLENOID SIGNAL

SPEED SENSORS (SJC)

Description

The speed sensors are used to monitor travel speed. The speed sensor communicates to the system by sending a pulse of electricity to the SJC controller.

Testing

Raise the lift arms and install an approved lift arm support device. (See Installing on Page 10-20-1.)

Raise the operator cab. (See Raising on Page 10-30-2.)

Connect the remote start tool to the loader. ((See REMOTE START TOOL KIT-MEL1563 on Page 10-60-1.) or (See REMOTE START TOOL (SERVICE TOOL) KIT - 7003031 on Page 10-60-1.)

Figure 60-80-1

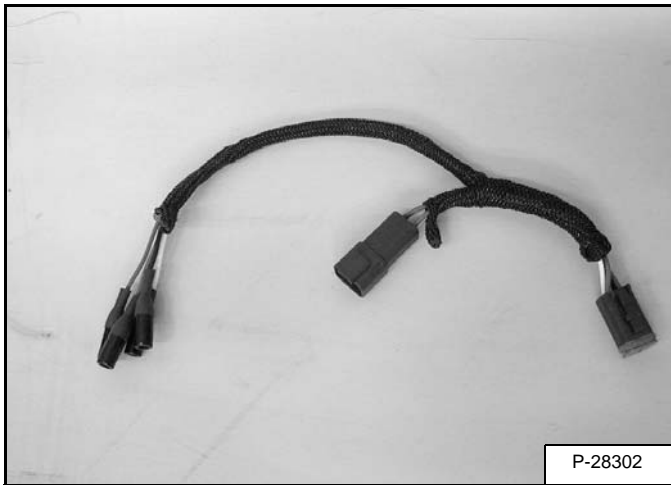

The tools listed will be needed to do the following procedure:

MEL1609-RPM Speed Sensor Test Harness **[Figure 60-80-1]**

MEL1563 or 7003031-Remote Start Tool

Multimeter

Figure 60-80-2

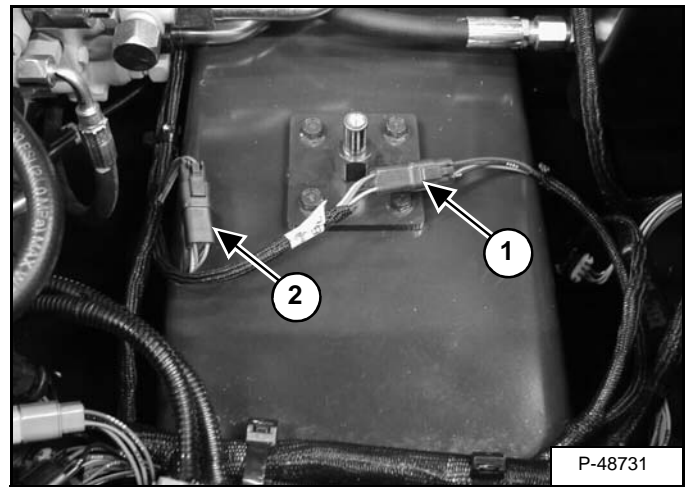

Locate the electrical connector (Item 1) **[Figure 60-80-2]** for the left rpm speed sensor.

Locate the electrical connector (Item 2) **[Figure 60-80-2]** for the right rpm speed sensor.

BOBCAT INTERLOCK CONTROL SYSTEM (BICS™)

Description

The Bobcat Interlock Control System is an electronic system that is used to protect the operator. The system consists of the traction lock, seat bar sensor and the lift and tilt lockouts solenoid.

These all have indicator lights on the left panel **[Figure 60-100-1]** of the loader cab.

The Press To Operate button activates the system and allows the operator to function the loader.

SEAT BAR SENSOR (CONT'D)

Bobcat Interlock Control System (BICS™) Circuit Test (Cont'd)

Figure 60-110-15

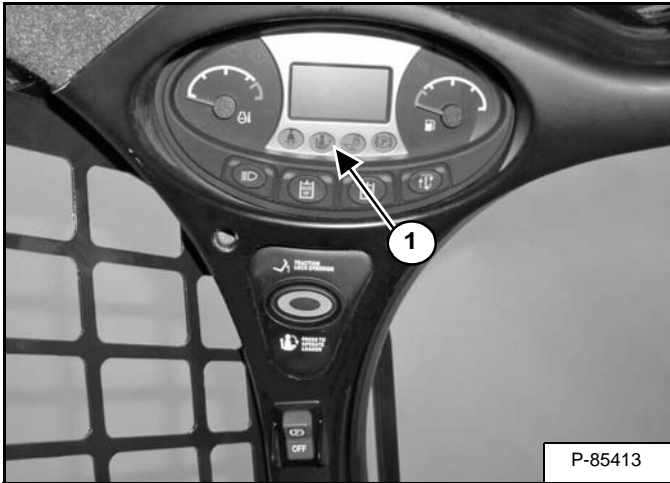

The BICS™ seat bar indicator light (Item 1) [Figure 60-110-15] should turn OFF.

Figure 60-110-16

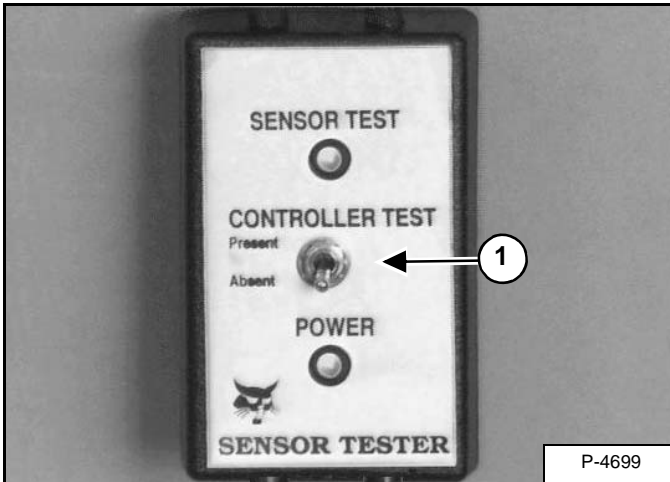

Move the toggle switch (Item 1) [Figure 60-110-16] on the sensor tester to the **Absent** position.

The Seat Bar light (Item 1) [Figure 60-110-15] should illuminate.

If the above test fails, there is a problem with the Bobcat Controller or the wiring harness.

CONTROL SYSTEM (ACS) (CONT'D)

Switch Handle Removal (Cont'd)

Figure 60-130-8

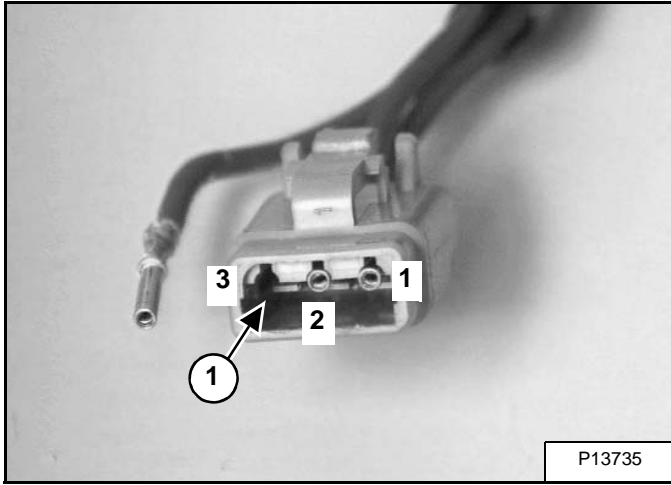

Use a pointed tool, press down on the tab (Item 1) [Figure 60-130-8] and pull the wire from the connector.

Figure 60-130-9

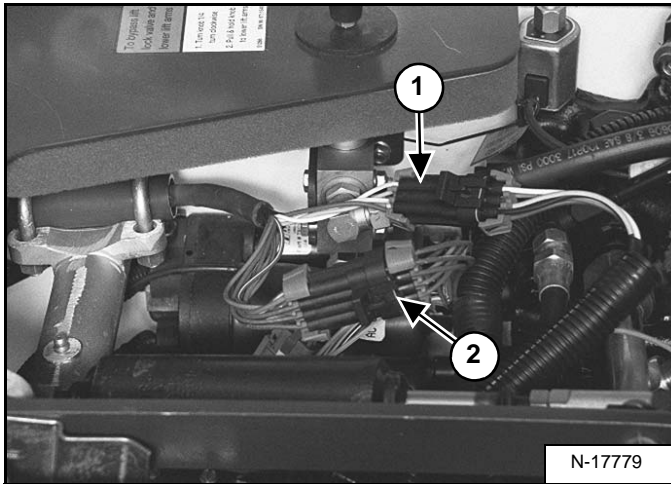

Disconnect the right switch handle connectors (Item 1 and 2) [Figure 60-130-9] from the loader wiring harness connectors.

Figure 60-130-10

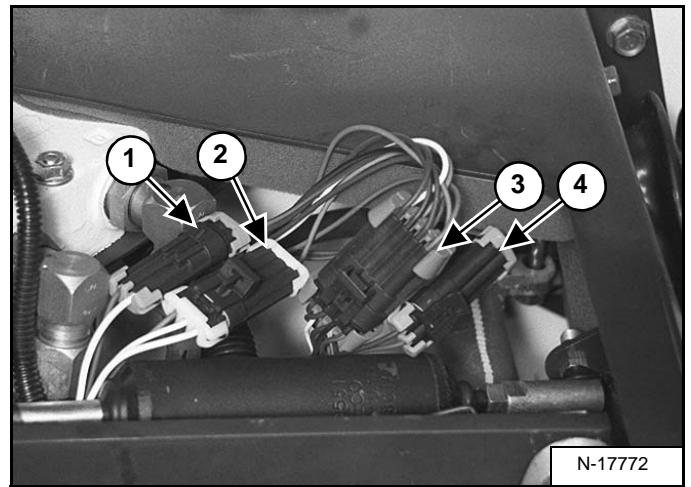

Disconnect the left switch handle connectors (Items 1, 2, 3 and 4) [Figure 60-130-10] from the loader wiring harness connectors.

Figure 60-130-11

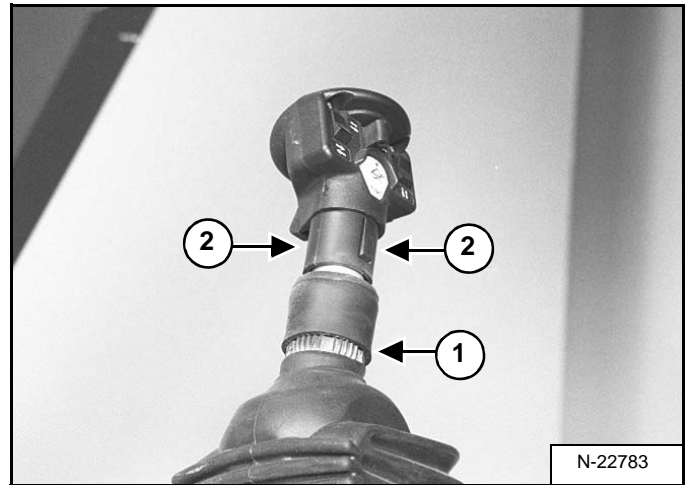

Roll the pistol grip handle cover (Item 1) [Figure 60-130-11] down.

Using a small screwdriver, lift the handle tabs (Item 2) [Figure 60-130-11] and slightly rotate the switch handle.

ELECTRICAL / HYDRAULIC CONTROLS (CONT'D)

Identification Chart ACD Group 0

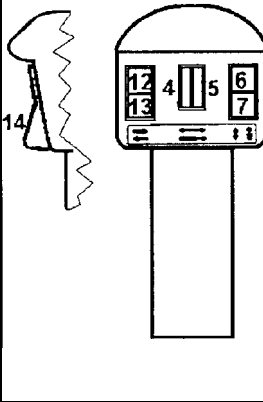
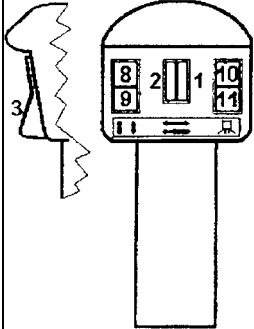
Left side Control Handle Switches	Switch Number	Solenoid Number Activated				Attachment Harness Terminal Activated	Attachment Harness Connector	Right Side Control Handle Switches
		STD	RH	HFH	RH / HFH			
	1	1	1	1, 7	1, 7	K		
	2	2	2	2	2	K		
	3	1	1	1, 7	1, 7	K		
	4	2	3,5,6	2	3,5,6	K,A,D		
	5	1	4,5,6	1	4,5,6	K,A,C		
	6	1	4,5,6	1	4,5,6	K,E		
	7	1	4,5,6	1	4,5,6	K,F		
	8	1	4,5,6	1	4,5,6	K,G		
	9	1	4,5,6	1	4,5,6	K,H		
	10, 11, 12, 13, 14	-	--	--		K		

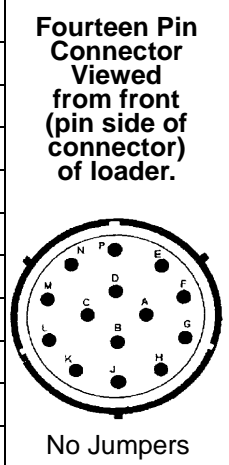

RH - Loaders with Rear Hydraulics Option.
 HFH - Loaders with High Flow Hydraulics Option.
 RH / HFH - Loaders with Rear Hydraulics and High Flow Hydraulics Option.
 Terminal K is activated with Key switch ON.

NOTE: For diagnostics and troubleshooting connect the Service PC (See SERVICE PC (LAPTOP COMPUTER) on Page 60-150-1.)

The ACD (Attachment Control Device) automatically recognizes the use of the seven or fourteen pin connector when connected.

Pressing the auxiliary hydraulics button and moving the rear auxiliary hydraulic switch to the right and left several times activates solenoid numbers 3,4,5, and 6 at the diverter valve.

Front Auxiliary Pressure Release is accomplished by manually pushing the male and female couplers in at the front auxiliary block.

The High Flow Button in the left side instrument panel must be pushed ON to activate solenoid number seven at the gear pump.

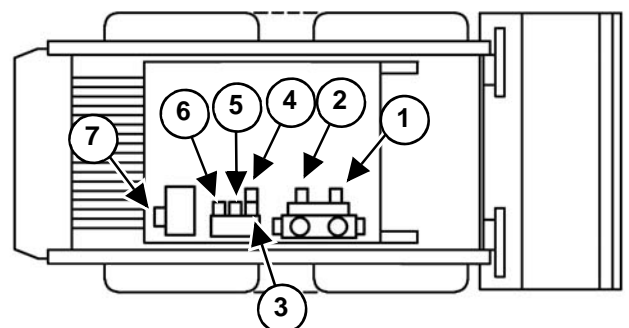

NA1891

Solenoid Number	Hydraulic Coupler	Wiring Number
1	Front Male (Rod)	4330
2	Front Female (Base)	4340
3	Diverter Rear (Rod)	4430
4	Diverter Rear (Base)	4440
5	Bleed / Lock Valve (Base)	4480
6	Bleed / Lock Valve (Rod)	4450
7	High Flow on Pump	4460

ELECTRICAL / HYDRAULIC CONTROLS (SJC)

Identification Chart

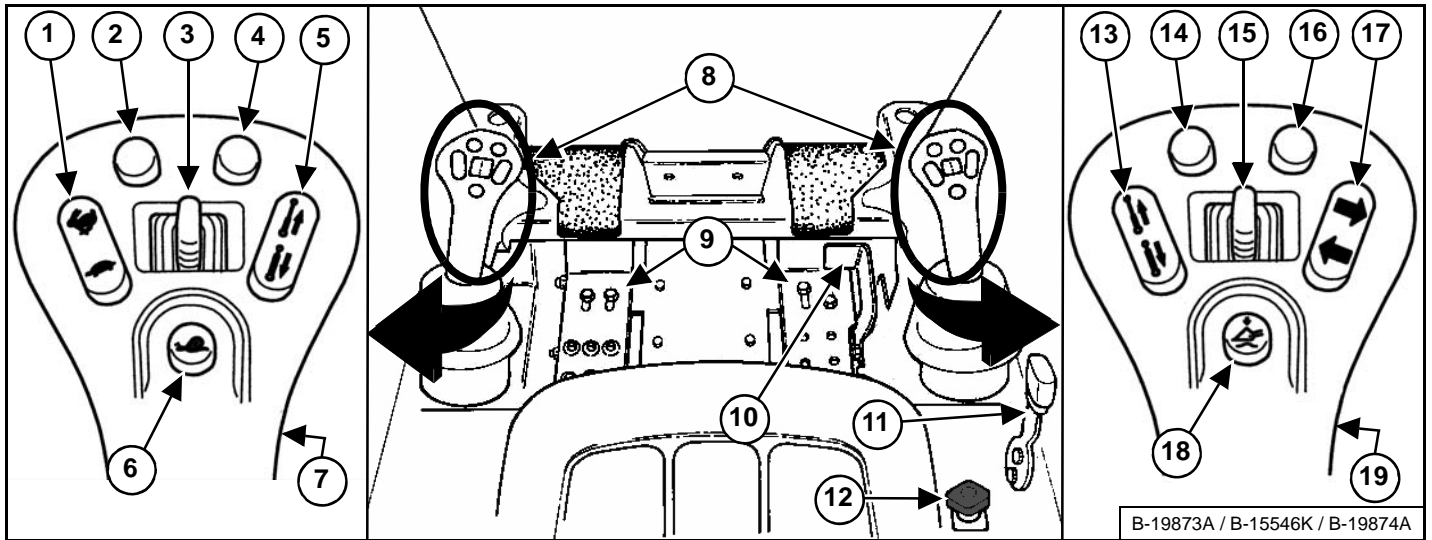

REF. NO.	DESCRIPTION
1	TWO-SPEED CONTROL (Option) Also: SPEED MANAGEMENT
* 2	STEERING DRIFT COMPENSATION Also: DRIVE RESPONSE
3	REAR AUXILIARY HYDRAULICS (Option) Also: ATTACHMENT FUNCTION CONTROL
* 4	STEERING DRIFT COMPENSATION Also: DRIVE RESPONSE
5	ATTACHMENT FUNCTION CONTROL
6	SPEED MANAGEMENT
7	FRONT HORN
8	JOYSTICKS
9	FOOTRESTS
10	ENGINE SPEED CONTROL (FOOT)
11	ENGINE SPEED CONTROL (HAND)
12	LIFT ARM BYPASS CONTROL
13	ATTACHMENT FUNCTION CONTROL
* 14	NOT USED
15	FRONT AUXILIARY HYDRAULICS
* 16	NOT USED
17	TURN SIGNALS (Option)
18	FLOAT CONTROL
19	CONTINUOUS FLOW CONTROL FOR AUXILIARY HYDRAULICS

* Also used as Attachment Function Control: See your attachment Operation & Maintenance Manual.

CALIBRATION (CONT'D)

Actuator Testing (Cont'd)

If the initial Actuator Test results in the fail mode actuator did not fully extend / retract, check the following.

- The actuator connectors may be reversed between the lift and tilt actuator. Reverse the connectors and rerun the Actuator Test.
- The actuator may be weak, replace the actuator.
- The spool end cap may be defective or the centering spring may be broken. Inspect the end cap and the centering spring, replace if necessary.
- Contamination in the spool.

If the initial Actuator Test results in the fail mode actuator out of neutral, check the following.

- The actuator may be defective, replace the actuator.
- The spool end cap may be defective or the centering spring may be broken. Inspect the end cap and the centering spring, replace if necessary.
- Contamination in the spool.

STEERING DRIFT COMPENSATION

Steering Drift Compensation is available on SJC equipped machines.

Description

Steering Drift Compensation can be used to reduce steering drift to maintain a desired travel path in both forward and reverse directions.

Examples of applications where this feature can be used:

- To compensate for normal variations such as tire inflation pressure, track tension, tire wear and track wear.
- Using side shift attachments such as trenchers, planers and silt fence installers.
- Driving on uneven terrain such as crowned road surfaces.

Figure 60-160-1

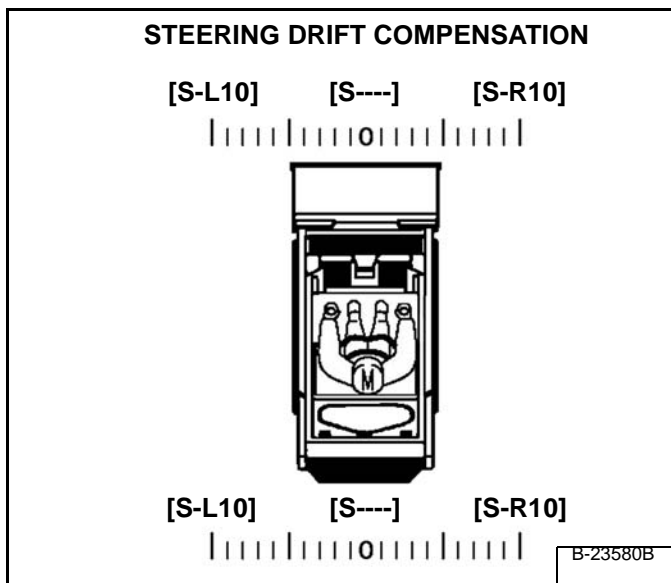

Steering drift compensation contains a total of 21 settings. Steering drift compensation can be set to any point from neutral to **[S-L10]** left and from neutral to **[S-R10]** right. **[S----]** is displayed when set for neutral **[Figure 60-160-1]**.

Operation

NOTE: Changes CANNOT be performed until the seat bar is lowered, the engine is started and the **PRESS TO OPERATE LOADER button is pressed to enable the BICS™.**

Perform pre-starting and starting procedures:

1. Fasten seat belt.
2. Lower seat bar.
3. Place joysticks in neutral position.
4. Start the engine.
5. Press the **PRESS TO OPERATE LOADER** button.
6. Current drive response setting will be displayed briefly in the data display.

NOTE: Raising the seat bar or changing control mode (ISO / H) will cause the machine to disengage from steering drift compensation. The last displayed setting will remain in effect until the **STOP button is pressed or the key is turned OFF.**

MAINTENANCE CLOCK

Description

The Maintenance Clock alerts the operator when the next service interval is due. *EXAMPLE:* The Maintenance Clock can be set to a 250 hour interval as a reminder for the next 250 hour planned maintenance.

Figure 60-200-1

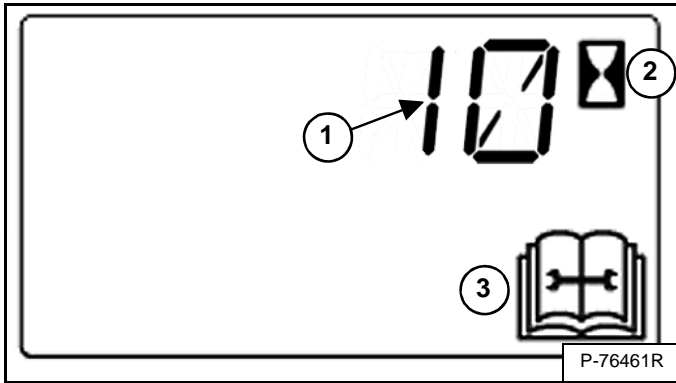

During machine operation, a two beep alarm will sound when there are less than 10 hours until the next planned maintenance.

The remaining hours before maintenance is required will appear in the data display (Item 1) for five seconds while the service icon (Item 3) and hourmeter icon (Item 2) [Figure 60-200-1] flash.

NOTE: The display will show negative numbers after counting down to zero.

The display will then revert back to the previous display and will appear for five seconds every time the machine is started until the maintenance clock is reset.

Figure 60-200-2

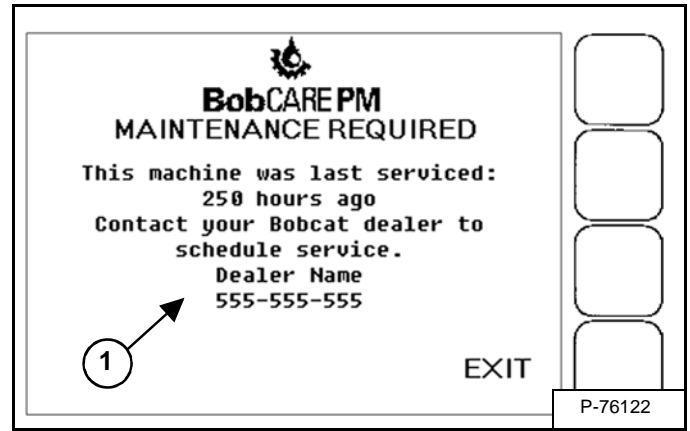

The Deluxe Instrumentation Panel, if equipped, will display a message (Item 1) [Figure 60-200-2] alerting the operator to service the machine.

This message will remain for 10 seconds before reverting back to the previous screen and will appear for 10 seconds every time the machine is started until the maintenance clock is reset.

Figure 60-200-3

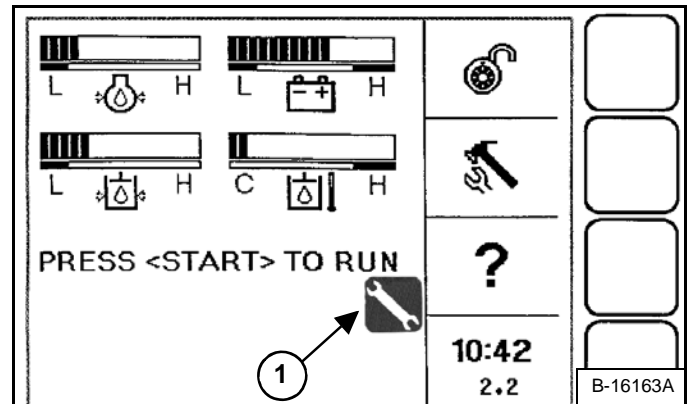

The Deluxe Instrumentation Panel, if equipped, will display a wrench icon (Item 1) [Figure 60-200-3] alerting the operator to service the machine. This icon will remain on the display until the maintenance clock is reset.

NOTE: Loaders equipped with a Standard Key Panel or Keyless Start Panel will not display the BobCARESM PM message or wrench icon on the right panel.

BACK-UP ALARM SYSTEM (CONT'D)

Alarm Removal And Installation

Stop the engine and open the tailgate.

Figure 60-210-4

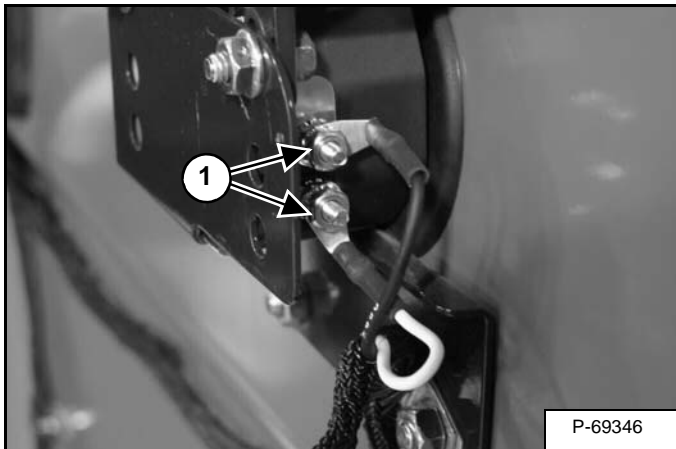

Mark the wires for ease of assembly. Disconnect the wires (Item 1) [Figure 60-210-4] from the alarm.

Installation: Make sure the wire harness ends do not touch the mounting bolts during assembly.

Figure 60-210-5

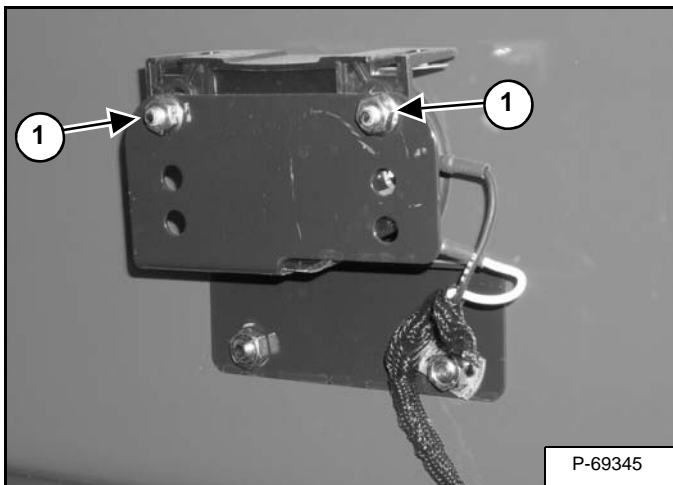

Remove the two hex head bolts, washers, and lock nuts (Item 1) [Figure 60-210-5]. Remove the alarm from the mounting bracket.

Switch Removal And Installation

NOTE: Joystick equipped machines do not have back-up alarm switches and can not be adjusted.

Standard Controls and ACS (If Equipped)

Stop the engine and raise the operator cab. (See Raising on Page 10-30-2.)

Figure 60-210-6

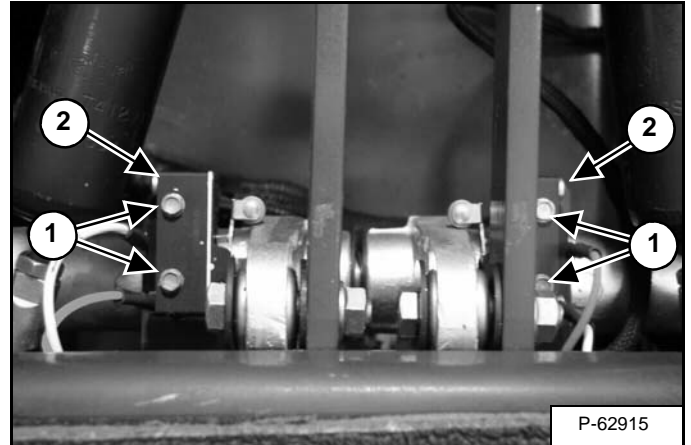

Place the steering levers in the neutral position.

Loosen the screws (Item 1) securing the back-up alarm switches. Slide the switch assemblies (Item 2) [Figure 60-210-6] off the mounting bracket.

Installation: Slide the alarm switches onto the mounting bracket so the threaded plates are under the mounting bracket. The rollers will face to the inside. During installation of switches, adjusting the switches (See Adjusting Switch Position on Page 60-210-2.) and inspecting back-up alarm operation (See Inspecting on Page 60-210-1.) are required.

ENGINE INFORMATION (CONT'D)

Specifications (Cont'd)

All dimensions are given in millimeters. Respective imperial dimensions are given in inches enclosed by parentheses.

Connecting Rod

Connecting Rod Alignment - Allowable Limit	0,05 mm (0.002 in)
Clearance Between Piston Pin And Small End Bushing	0,020 - 0,040 mm (0.00079 - 0.0015 in)
Allowable Limit	0,15 mm (0.0059 in)
Piston Pin O.D.	30,006 - 30,011 mm (1.1814 - 1.1815 in)
Small End Busing I.D.	30,031 - 30,046 mm (1.1824 - 1.1829 in)

Cylinder Bore

Cylinder Bore I.D.	100,000 - 100,022 mm (3.93701 - 3.93787 in)
Allowable Limit	100,150 mm (3.9429 in)
Oversized Cylinder Liner I.D.	100,500 - 100,522 mm (3.95670 - 3.95755 in)
Allowable Limit	100,650 mm (3.96260 in)

Crankshaft

Crankshaft Alignment - Allowable Limit	0,02 mm (0.0008 in)
Crankpin O.D.	52,977 - 52,990 mm (2.0857 - 2.0862 in)
Crankshaft Journal O.D.	74,977 - 74,990 mm (2.9519 - 2.9523 in)
Oil Clearance Between Crankshaft Journal And Crankshaft Bearing	0,018 - 0,062 mm (0.00071 - 0.0024 in)
Allowable Limit	0,20 mm (0.0079 in)
Oil Clearance Between Crank Pin And Pin Bearing	0,018 - 0,051 mm (0.00071 - 0.0020 in)
Allowable Limit	0,20 mm (0.0079 in)
Crankshaft Side Clearance	0,015 - 0,31 mm (0.0059 - 0.012 in)
Allowable Limit	0,50 mm (0.020 in)

ENGINE INFORMATION (CONT'D)

Engine Removal And Installation (Cont'd)

Figure 70-10-18

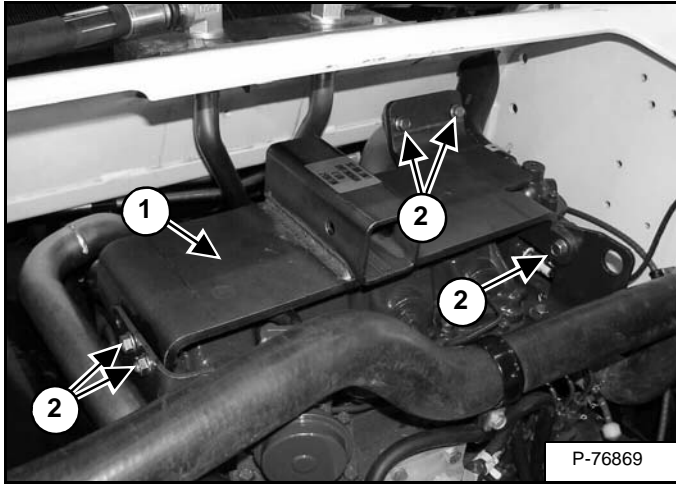

Install the engine removal bracket (Item 1) on the engine using the five holes (Items 2) [Figure 70-10-18].

Installation: Use 9.525 mm x 38,1mm (0.375 in x 1.5 in) bolts and nuts.

Tighten the all bolts and nuts that hold the engine removal bracket onto the engine.

Figure 70-10-19

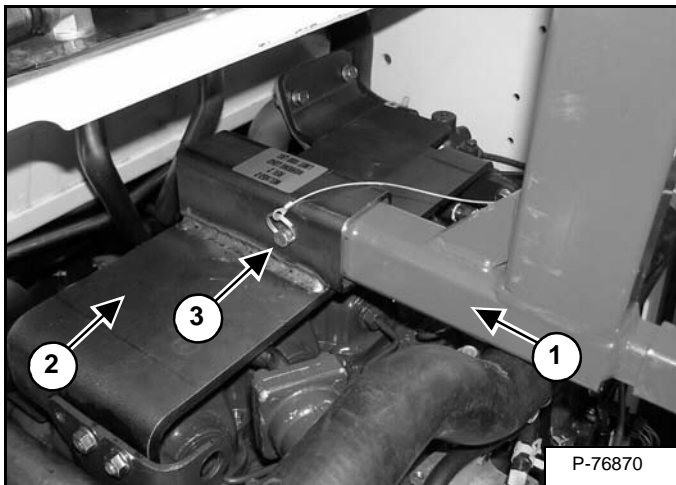

Install the engine removal tool (Item 1) into the attachment (Item 2) and insert the pin (Item 3) [Figure 70-10-19].

Figure 70-10-20

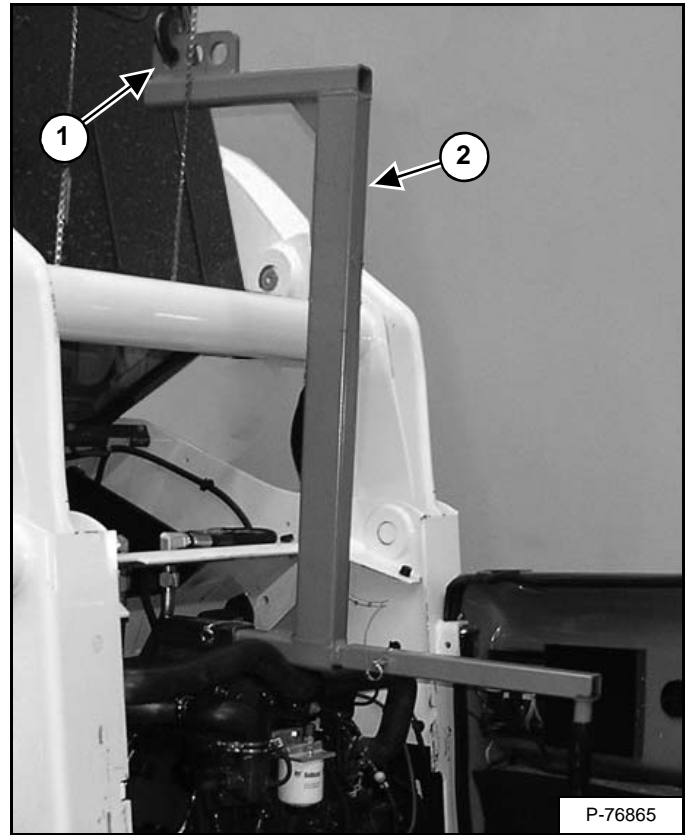

Connect a chain hoist to the first hole (Item 1) on the engine removal tool (Item 2) [Figure 70-10-20].

Remove the engine / hydrostatic pump assembly from the loader.

MUFFLER

Removal And Installation

Figure 70-30-1

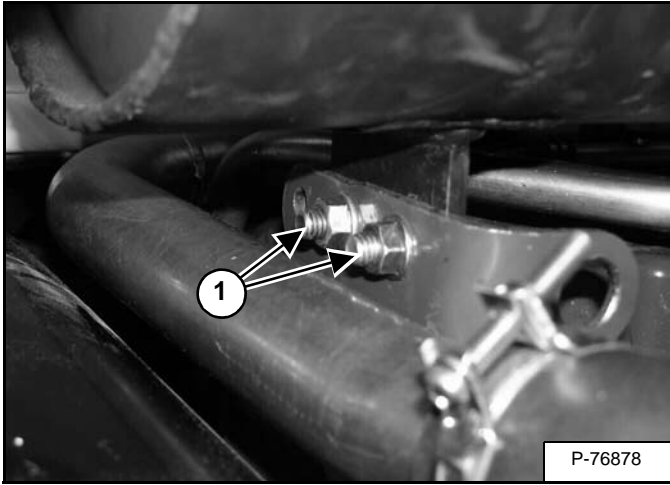

Open the rear door.

Remove the rear grille.

Remove the two bolts and nuts (Item 1) [Figure 70-30-1] from the left end of the engine muffler.

Figure 70-30-2

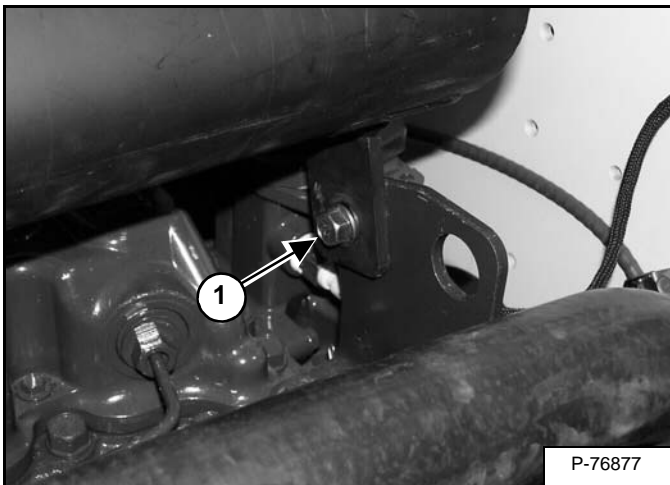

Remove the bolt and nut (Item 1) [Figure 70-30-2] from the right end of the engine muffler.

Figure 70-30-3

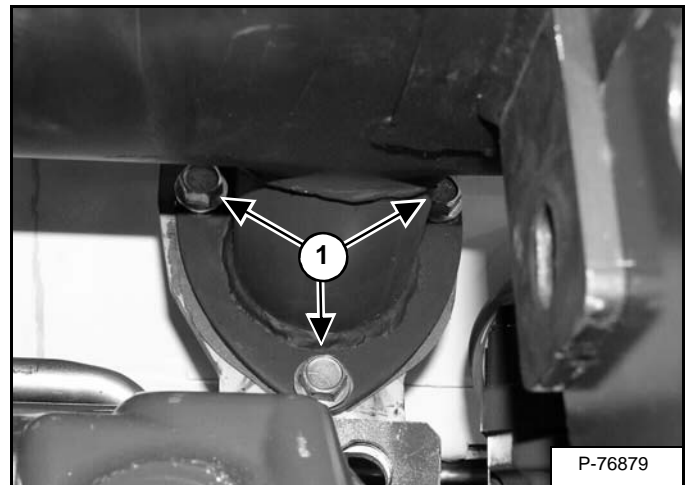

Remove the three bolts and nuts (Item 1) [Figure 70-30-3] from the muffler mounting bracket.

Remove the muffler from the loader.

ENGINE COOLING SYSTEM (CONT'D)

Axial Fan Housing Removal And Installation (Cont'd)

Figure 70-50-21

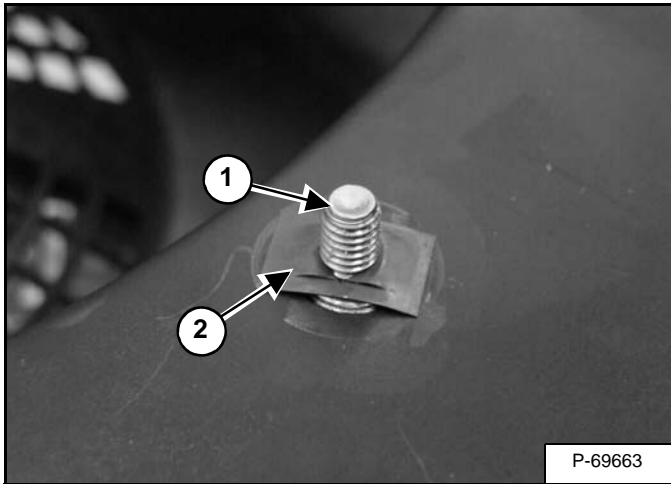

NOTE: The picture shows the fan housing and fan assembly removed from the loader. Two of the mounting bolts (Item 1) have clips (Item 2) [Figure 70-50-21] to hold the bolts from falling out during installation.

Remove the axial fan housing from the loader.

Axial Fan Removal And Installation

Figure 70-50-22

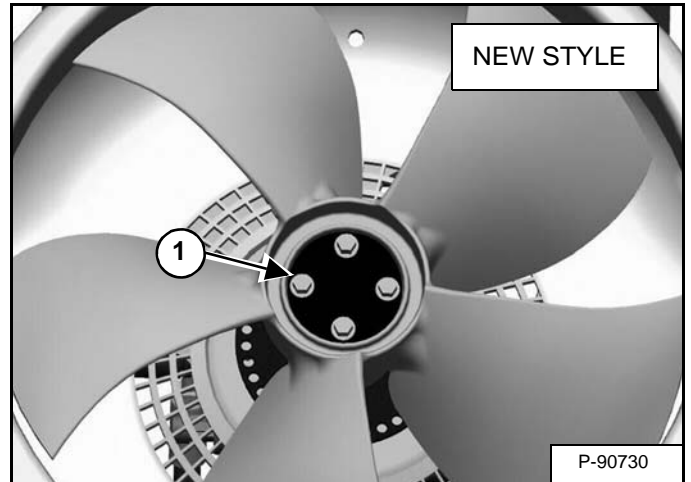
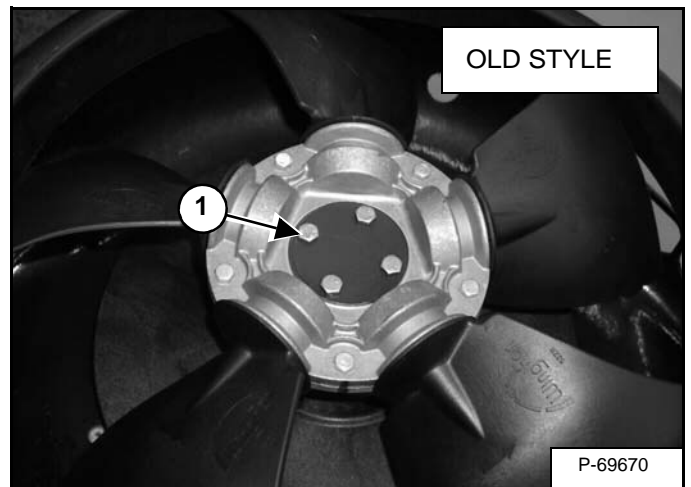

Figure 70-50-23



NOTE: Two different axial fans are used based on the shaft of the hydraulic fan motor. (See Hydraulic Fan Motor Description on Page 70-50-4.) The removal and installation is the same for both.

NOTE: The new style axial fan can **ONLY** be used with the hydraulic fan motor (sculpted shaft).

Remove the four bolts (Item 1) [Figure 70-50-22] or [Figure 70-50-23] to remove the plate and the upper fan.

LUBRICATION SYSTEM (CONT'D)

Oil Filter Cooler Removal And Installation (Cont'd)

Figure 70-60-11

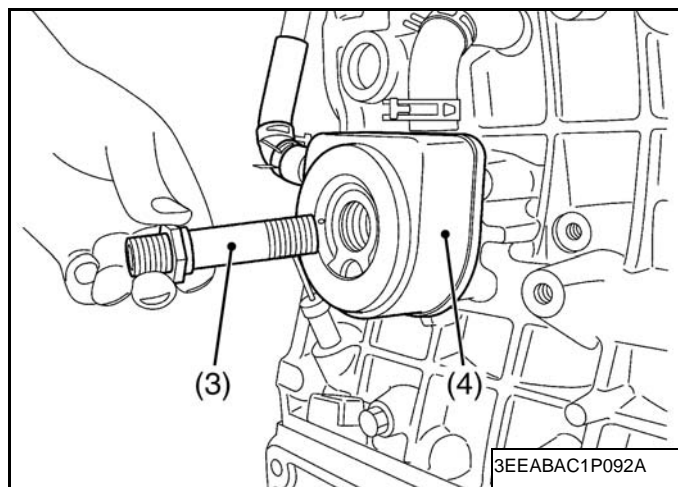

Remove the oil cooler (Item 4) [Figure 70-60-11].

Engine Oil Pressure - Testing

Figure 70-60-12

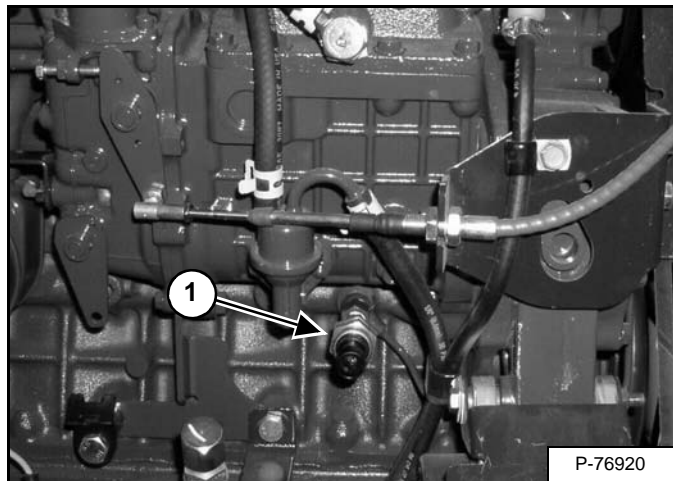

Remove the oil switch (Item 1) [Figure 70-60-12].

FUEL SYSTEM (CONT'D)

Governor Housing Disassembly And Assembly (Cont'd)

Figure 70-70-28

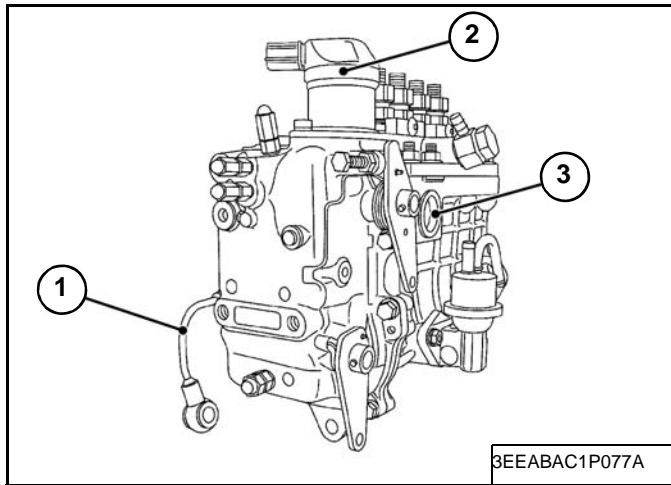

Remove the injection pump unit from the engine.

Remove the governor lubricating pipe (Item 1) [Figure 70-70-28].

Remove the stop solenoid (Item 2) [Figure 70-70-28].

Detach the sight cover (Item 3) [Figure 70-70-28] from the injection pump unit.

Figure 70-70-29

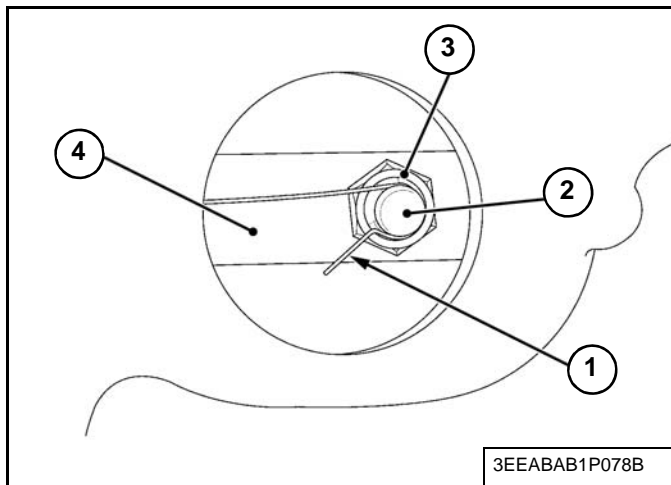

Unhook the start spring (Item 1) from the rack pin (Item 2) [Figure 70-70-29] of injection pump assembly.

Remove the nut (Item 3) [Figure 70-70-29].

NOTE: Be careful not to drop the nut inside.

NOTE: (See Fuel Injection Pump Removal on Page 70-70-14.) for proper alignment of the governor connection rod procedure. The procedure will require a special tool part number MEL1637.

Figure 70-70-30

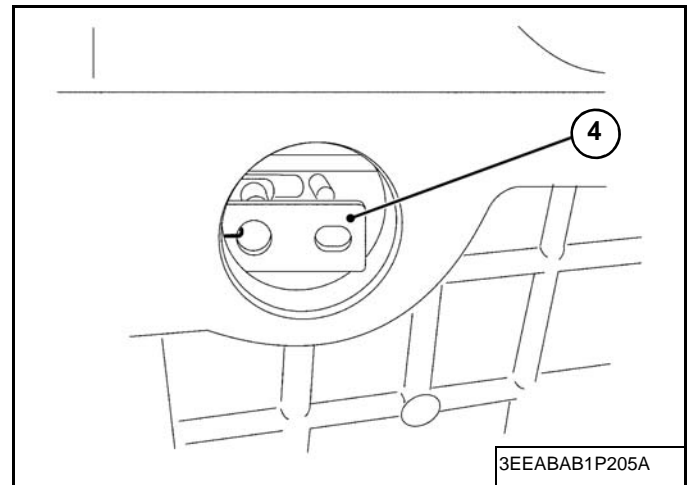

Slide off the governor connecting rod (Item 4) [Figure 70-70-29] and [Figure 70-70-30] from the rack pin of injection pump assembly.

For convenient sake, temporarily hook the start spring on the rack pin hole of the governor connecting rod.

Remove the governor housing mounting bolts.

Figure 70-70-31

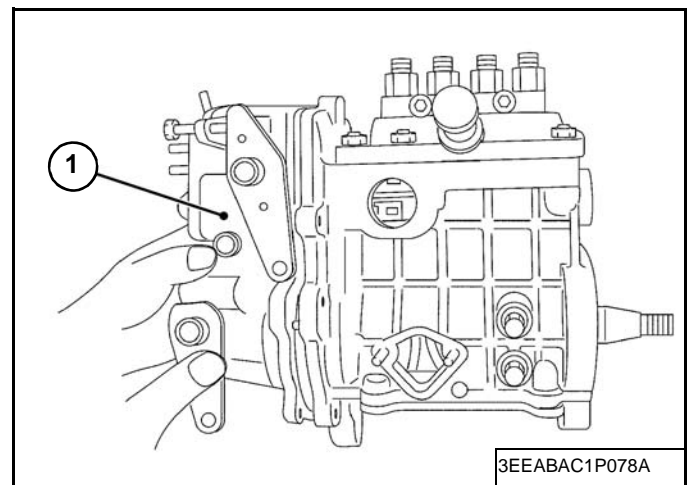

Detach the governor housing assembly (Item 1) [Figure 70-70-31] from the injection pump unit.

NOTE: The injection pump unit is lubricated with engine oil. Oil will leak when the governor housing is removed from the injection pump.

FUEL SYSTEM (CONT'D)

Fuel Injection Pump Installation (Cont'd)

Figure 70-70-62

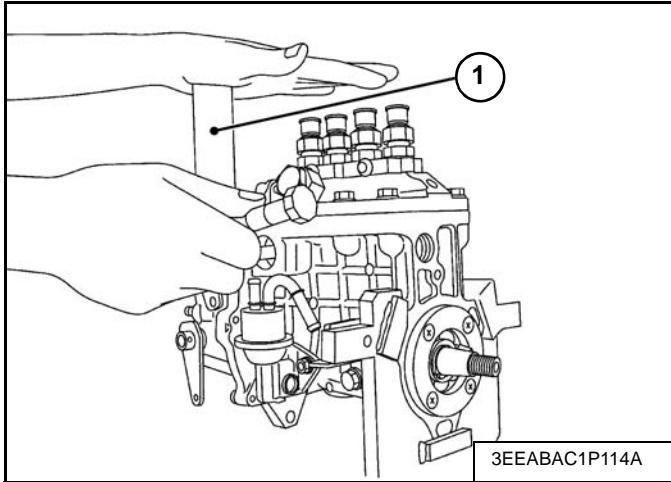

Make sure the permanent magnet at the top of the jig (Item 1) is attracted to the governor connecting rod (Item 2). To do this, turn the jig a little clockwise and counterclockwise and look into the sight cover hole to see if the governor connecting rod (Item 2) [Figure 70-70-60] moves right and left accordingly [Figure 70-70-61] and [Figure 70-70-62].

Figure 70-70-63

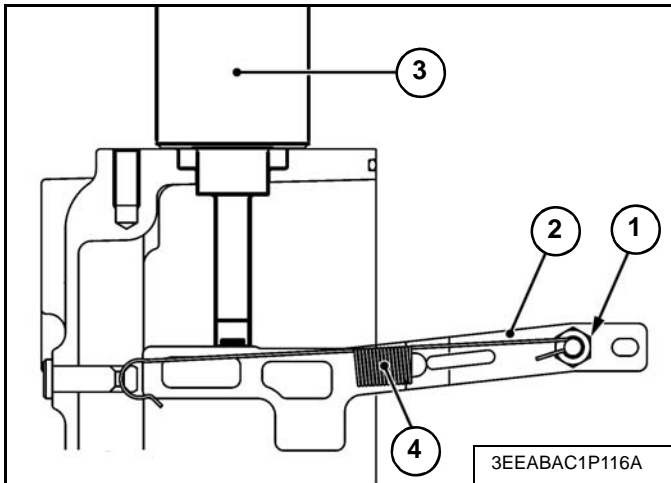

Slightly tighten the anti-rotation nut (Item 1) of the governor connecting rod (Item 2) [Figure 70-70-63].

Holding down the jig (Item 3) by hand, tighten up the anti-rotation nut to the specified torque.

Tighten the anti-rotation nut (Item 1) [Figure 70-70-63] to 2,8 - 4,0 N•m (2.1 - 2.9 ft-lb) torque.

Figure 70-70-64

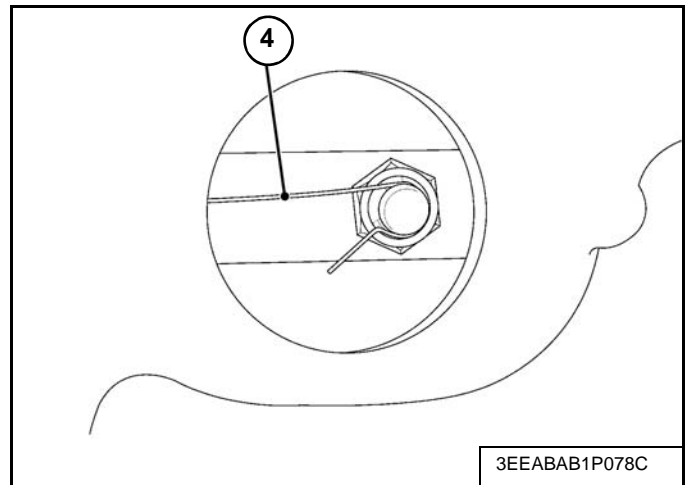

Hook the start spring (Item 4) [Figure 70-70-64] and [Figure 70-70-63] to the rack pin.

CYLINDER HEAD (CONT'D)

Valve Clearance Adjustment (Cont'd)

Figure 70-80-9

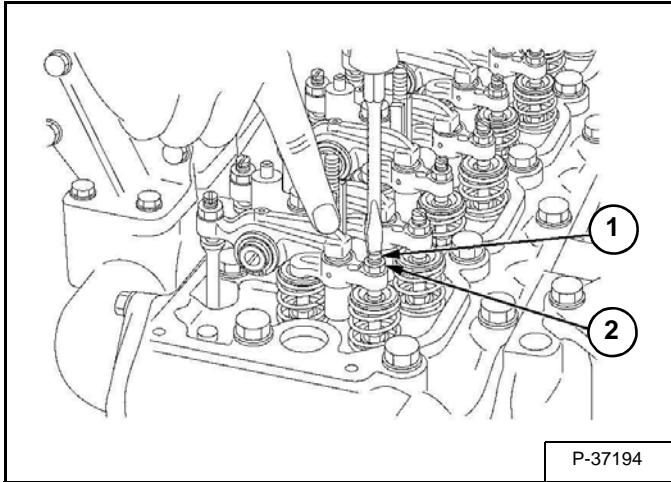

Before adjusting the valve clearance, adjust the bridge to set the height of valves.

Loosen the lock nut (Item 2) and turn the adjusting screw (Item 1) [Figure 70-80-9] to adjust the bridge.

Apply pressure with your finger to the rocker arm and screw in the adjusting screw slowly until you feel the screw touch the top of valve stem, then tighten the lock nut.

Figure 70-80-10

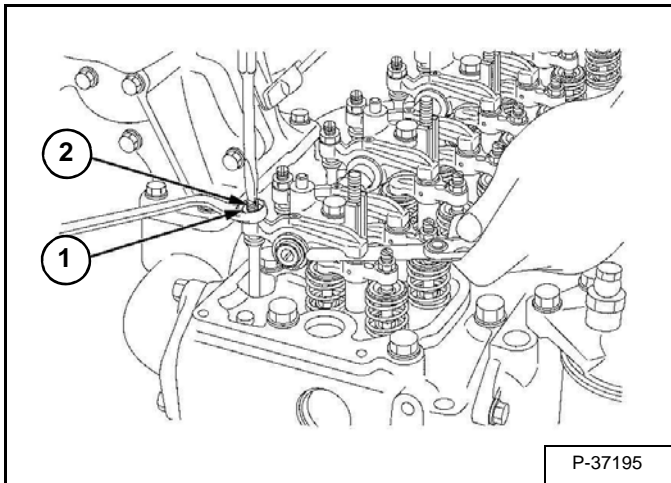

Loosen the lock nut (Item 1) of adjusting screw (Item 2) [Figure 70-80-10] (push rod side) and insert the thickness gauge between the rocker arm and the bridge

head. Set the adjusting screw to the specified value, then tighten the lock nut.

Valve clearance	Factory spec.	0,23 - 0,27 mm (0.0091 - 0.010 in)
-----------------	---------------	---------------------------------------

NOTE: After adjusting, tighten the lock nut (Item 2) [Figure 70-80-10] securely.

Valve arrangement Adjustment cylinder Location of piston		IN.	EX.
When No. 1 piston is compression top dead center	1st	*	*
	2nd	*	
	3rd		*
	4th		
When No. 1 piston is overlap position	1st		
	2nd		*
	3rd	*	
	4th	*	*

CYLINDER HEAD (CONT'D)

Valve Tappets

Figure 70-80-34

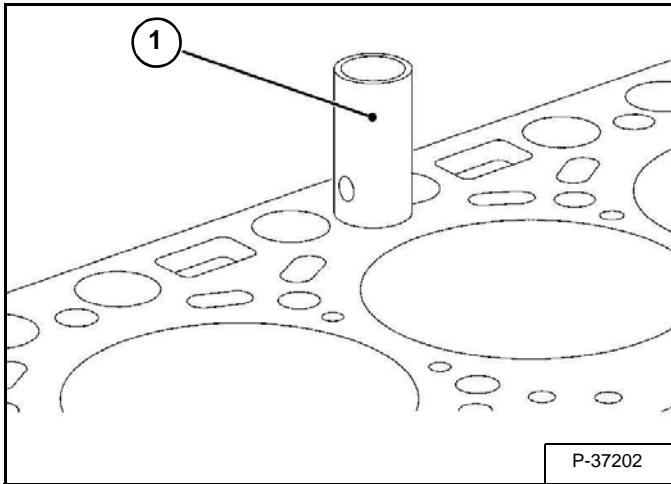

Remove the tappets (Item 1) [Figure 70-80-34] from the crankcase.

When reassembling replace the head gasket with a new one.

Before installing the tappets (Item 1) [Figure 70-80-34], apply engine oil thinly around them.

NOTE: Mark the cylinder number to the tappets to prevent interchanging.

Figure 70-80-35

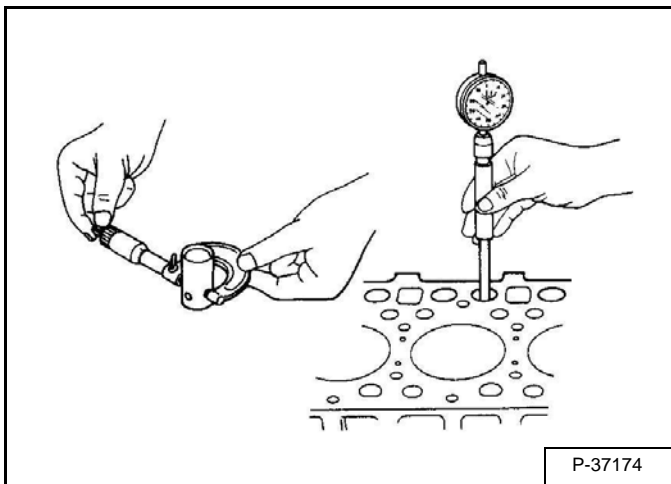

Measure the tappet O.D. with an outside micrometer [Figure 70-80-35].

Measure the I.D. of the tappet guide bore with a cylinder gauge, and calculate the oil clearance [Figure 70-80-35].

If the oil clearance exceeds the allowable limit or the tappet is damaged, replace the tappet.

Oil clearance between tappet and guide	Factory spec.	0,020 - 0,062 mm (0.00079 - 0.0024 in)
	Allowable limit	0,07 mm (0.003 in)

Tappet O.D.	Factory spec.	23,959 - 23,980 mm (0.94327 - 0.94409 in)
Tappet guide I.D.	Factory spec.	24,000 - 24,021 mm (0.94489 - 0.94570 in)

CRANKSHAFT AND PISTONS (CONT'D)

Crankshaft And Bearings Removal

Remove the flywheel housing. (See Housing Removal And Installation on Page 70-120-2.)

Remove the oil pan. (See Oil Pan Removal And Installation on Page 70-60-1.)

Figure 70-90-22

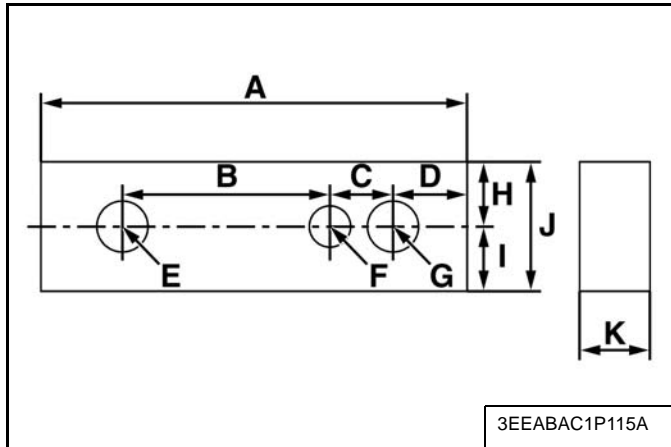

Application: Use for aligning the crankcase 1 and 2.

A	115 mm (4.5276 in)
B	56 mm (2.2047 in)
C	17 mm (0.6693 in)
D	20 mm (0.7874 in)
E	14 mm dia (0.5512 in dia)
F	11 mm dia (0.4331 in dia)
G	14 mm dia (0.5512 in dia)
H	17,5 mm (0.6890 in)
I	17,5 mm (0.6890 in)
J	35 mm (1.3780 in)
K	19mm (0.7480 in)

Figure 70-90-23

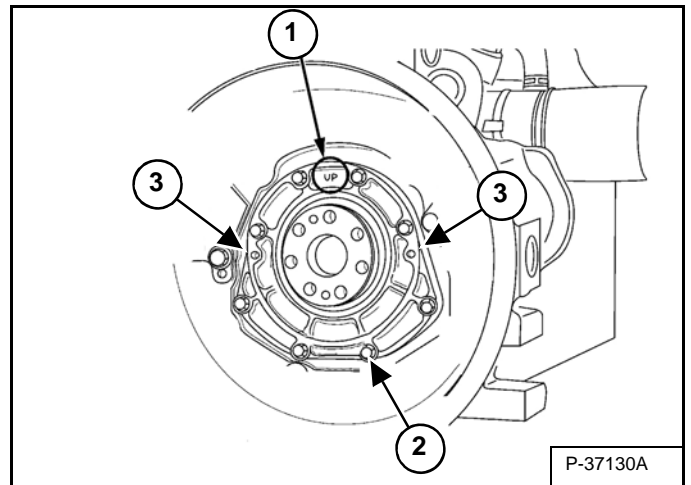

NOTE: Before disassembling, check the side clearance of crankshaft. Also check it during reassembly. Check the crankshaft side clearance. (See on Page 70-90-14.)

Remove the eight bearing case cover mounting screws (Item 2) [Figure 70-90-23].

Install the two screws removed earlier into the screw hole (Item 3) [Figure 70-90-23] of bearing case cover to remove it.

NOTE: Install the bearing case cover / oil seal assembly with the casting mark labeled "UP" (Item 1) [Figure 70-90-23] at the top.

CAMSHAFT AND TIMING GEARS

Timing Gearcase Cover Removal And Installation

Figure 70-100-1

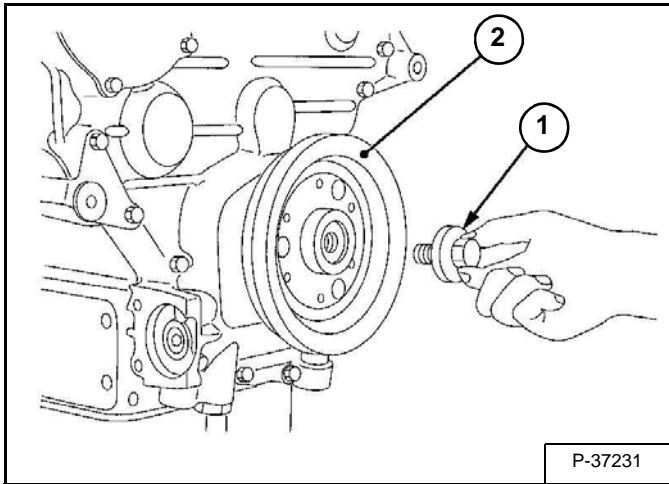

Install the engine flywheel pin.

Remove the crankshaft screw (Item 1) [Figure 70-100-1].

Remove the drive pulley (Item 2) [Figure 70-100-1].

NOTE: Clean the crankshaft screw and the drive pulley sleeve surface thoroughly and tighten the screw securely to specified torque.

Tightening torque	Crankshaft screw	255,0 - 274,6 N•m (188.1 - 202.5 ft-lb)
-------------------	------------------	--

Figure 70-100-2

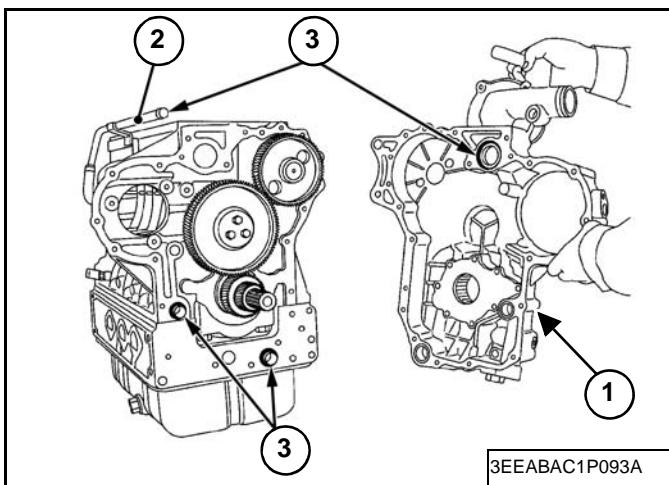

Remove the gearcase cover (Item 1) [Figure 70-100-2].

NOTE: Use care when removing the gearcase cover not to damage the water pipe (Item 2) [Figure 70-100-2].

Figure 70-100-3

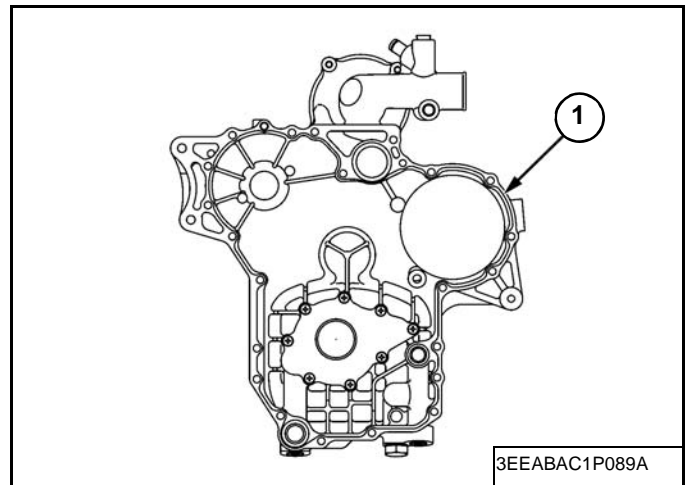

Confirm that the liquid gasket coating surface is free of water, dust and oil in order to maintain sealing effect.

Carefully apply the adhesive evenly (Item 1) [Figure 70-100-3].

NOTE: Apply a liquid gasket to the gearcase cover.

NOTE: Assemble the adhesive-applied parts within the manufactures specified cure time.

Figure 70-100-4

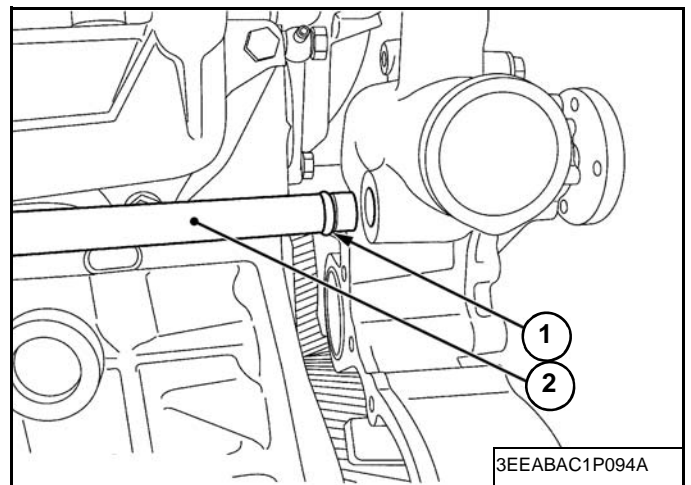

Be careful not to damage the O-ring (Item 1) and water pipe (Item 2) [Figure 70-100-4].

NOTE: Use the new O-rings (Item 3) [Figure 70-100-2] when attaching gearcase cover.

EXHAUST GAS RECIRCULATION (EGR) SYSTEM

Description

Exhaust Gas Recirculation (EGR) is a system in which the exhaust gas with lean oxygen is cooled and returned to the cylinders again in order to lower the combustion temperature.

An External / Mechanical EGR consists of a water cooled EGR cooler, mechanical EGR valve, reed valve and thermo valve. When the coolant temperature is high and the boost pressure is low, the EGR valve will not open. If the coolant temperature is high and the boost pressure is also high, the EGR valve will open allowing cooled gas back into the intake manifold.

The reed valve between the EGR valve and the intake manifold prevents fresh air from flowing into EGR system.

Figure 70-130-1

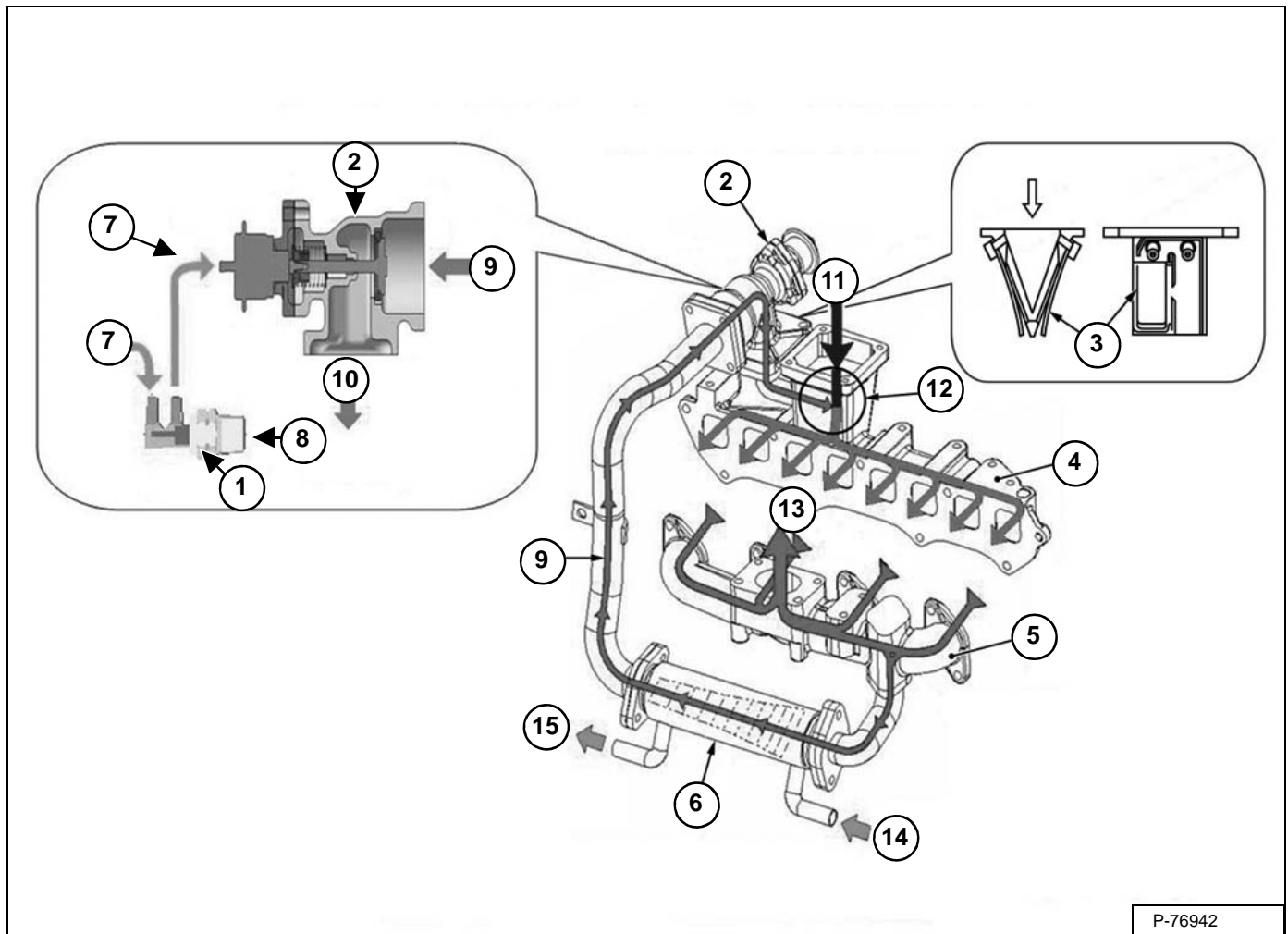

P-76942

The items listed below refer to Page 70-130-1 [Figure 70-130-1].

- | | |
|-------------------------|--|
| 1. Thermo Valve | 9. Cooled EGR Gas |
| 2. Mechanical EGR Valve | 10. To The Intake Manifold |
| 3. Reed Valve | 11. Fresh Air |
| 4. Intake Manifold | 12. Cooled EGR Gas Merges With Fresh Air |
| 5. Exhaust Manifold | 13. Exhaust |
| 6. EGR Cooler | 14. Coolant Inlet |
| 7. Boost Pressure | 15. Coolant Outlet |
| 8. Coolant Temperature | |

AIR CONDITIONING SYSTEM FLOW (CONT'D)

Chart

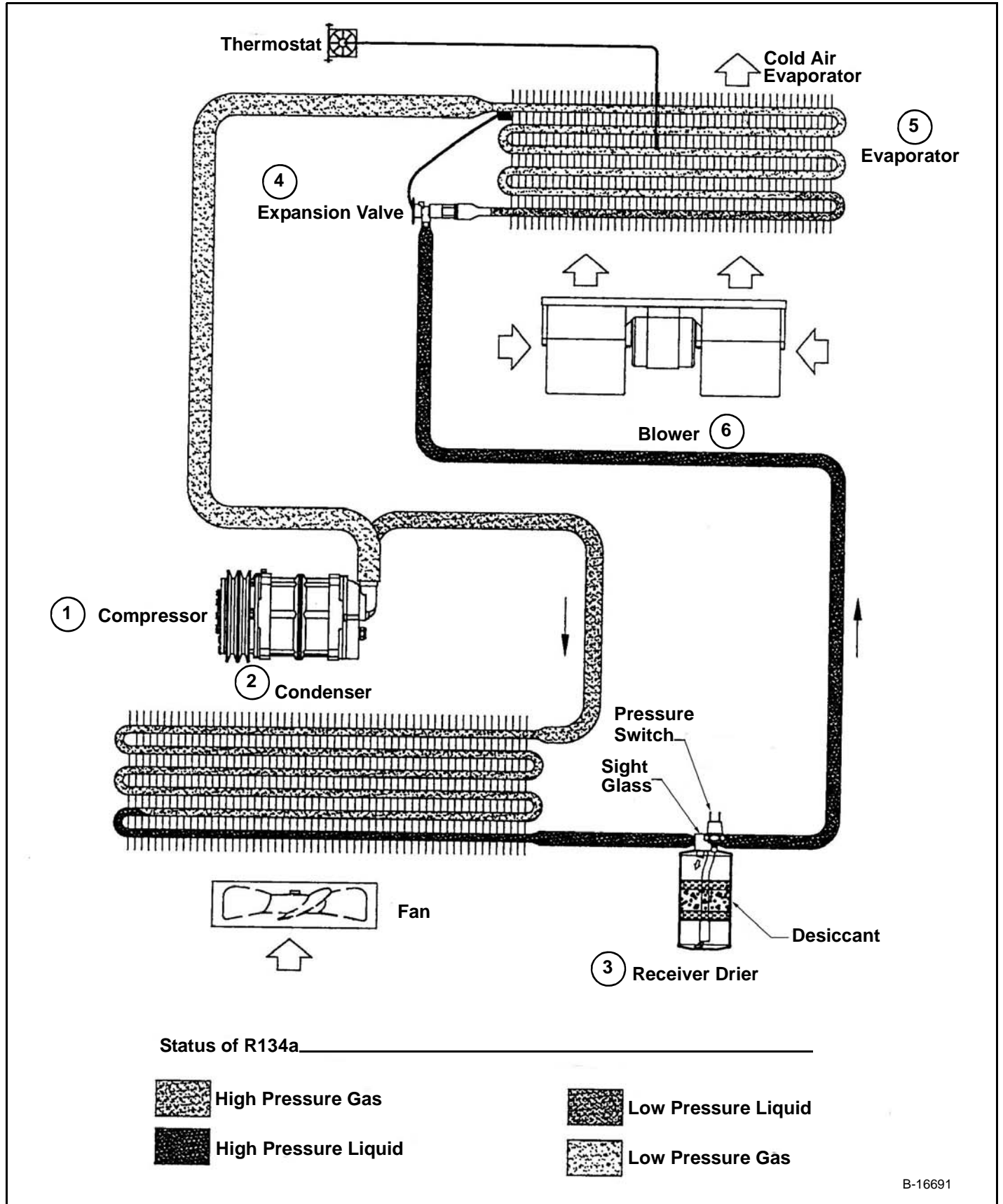

REGULAR MAINTENANCE (CONT'D)

Evaporator / Heater Coil

Raise the operator cab. (See Raising on Page 10-30-2.)

Figure 80-20-5

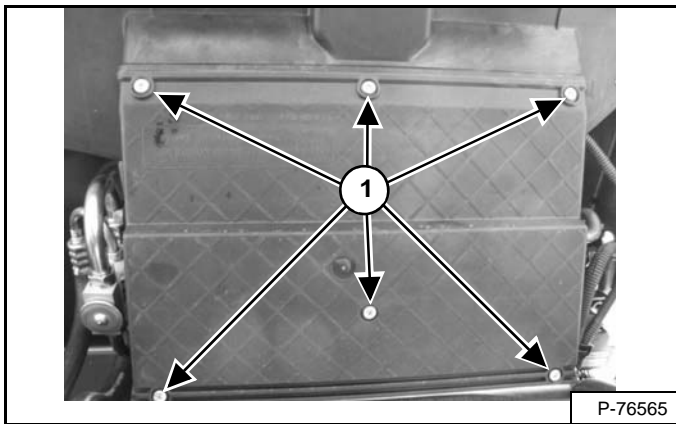

Remove the cover screws (Item 1) [Figure 80-20-5] and remove the cover.

Figure 80-20-6

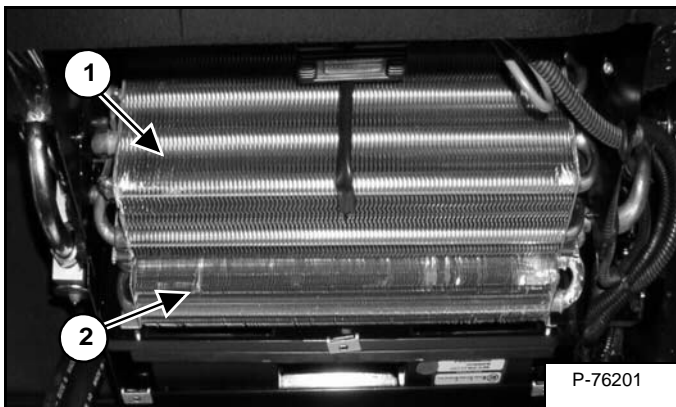

Use low pressure air or water to remove debris from the evaporator (Item 1) and heater coil (Item 2) [Figure 80-20-6].

Install the cover and lower the operator cab. (See Lowering on Page 10-30-3.)

TROUBLESHOOTING (CONT'D)

Temperature / Pressure Chart (Cont'd)

Evaporator

Pressures represent gas temperatures inside the coil. not the coil surface. For an estimate of the temperature of the air coming off the coil add -13 - -12°C (8 - 10°F) to the temperature on the chart.

Condenser

Temperatures are not ambient temperatures but condensing temperatures. Add 4.4°C (40°F) to the ambient temperature to get the condensing temperature and then refer to the pressure chart to see appropriate pressure for ambient temperature.

Example: Ambient

Temperature=90°F

90°F

+40°F

130°F condenser temperature=200 PSG

Conditions and pressures will vary from system to system. Check with MCC for system specifications.

TROUBLESHOOTING (CONT'D)

Electrical System (Cont'd)

Figure 80-30-29

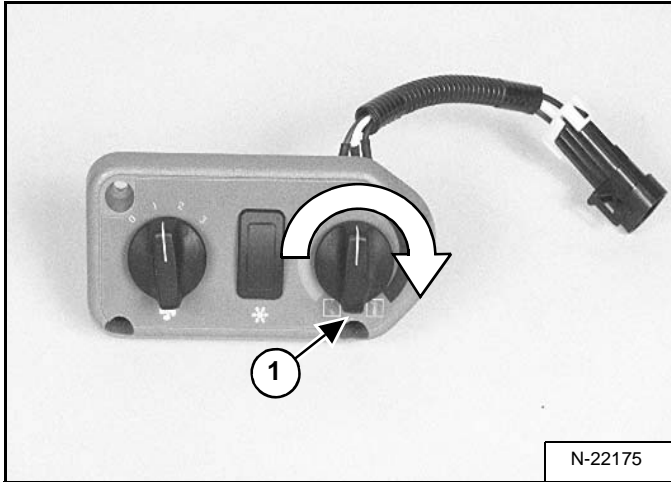

To check the resistance of the white wire, turn the potentiometer control (Item 1) [Figure 80-30-29] to the full Heater position.

Figure 80-30-30

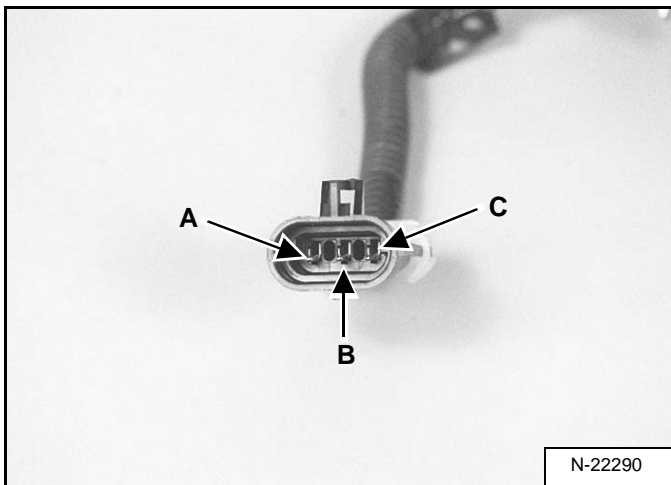

Check the resistance between the wire terminal **A** and wire terminal **B** frame [Figure 80-30-30] should be around 39K ohm.

Check the resistance between the wire terminal **C** and wire terminal **B** frame [Figure 80-30-30] should be around 49K ohm.

If the resistance is not found replace the potentiometer.

Engine Coolant Bypassing The Heater Valve

Raise the lift arms and install an approved lift arm support device. (See Installing on Page 10-20-1.)

Figure 80-30-31

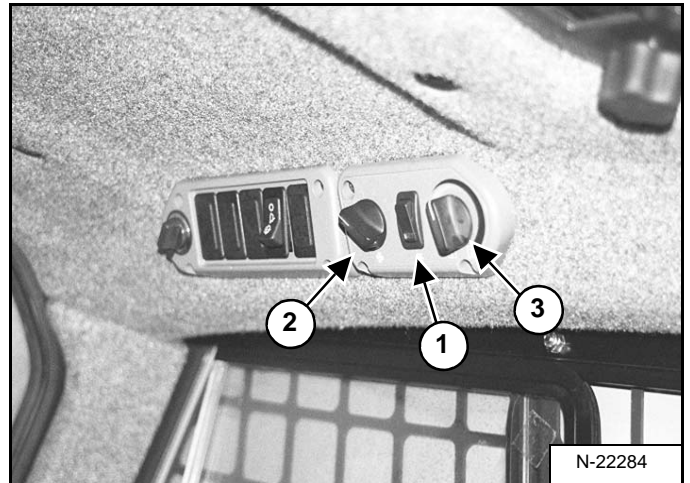

Push the A/C switch (Item 1) to the OFF position, turn the blower switch (Item 2) to position **1**, then turn the temperature control (Item 3) [Figure 80-30-31] to the High A/C position, with the loader ignition switch OFF.

Raise the operator cab. (See Raising on Page 10-30-2.)

Connect the remote start tool to the loader. (See REMOTE START TOOL KIT-MEL1563 on Page 10-60-1.)

Start the loader and run at high idle, for ten minutes.

Figure 80-30-32

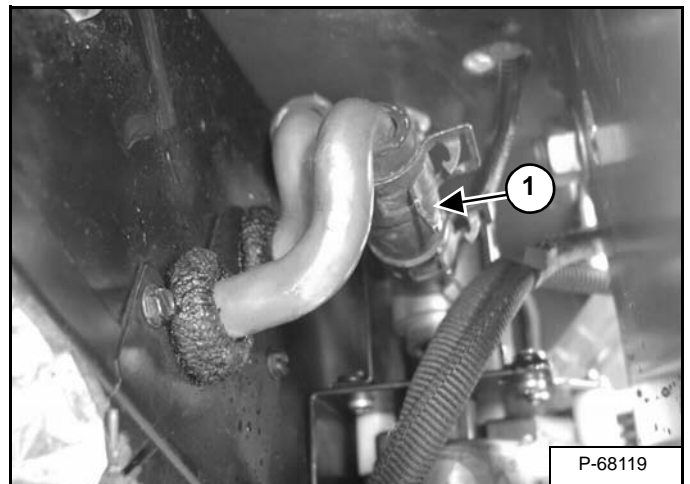

Check the heater hose (Item 1) [Figure 80-30-32] for temperature.

If the hose is hot, the heater valve is leaking by, and needs to be replaced.

COMPRESSOR (CONT'D)

Oil Check

The compressor oil should be checked as follows when oil is being added to an in service loader.

There is a close affinity between oil and refrigerant. During normal operation, part of the oil circulates with the refrigerant in the system. Therefore, when checking the amount of oil in the system or replacing any system component, the compressor must be run in advance to insure return of oil to the compressor.

If the amount of refrigerant in the system has decreased, charge the system. (See Reclamation And Charging With Recovery / Charging Unit on Page 80-40-2.)

Open the cab door and windows.

Run the blower at maximum speed.

Run the compressor for at least 20 minutes at 800 - 1200 rpm.

Remove the compressor from the loader. (See Removal And Installation on Page 80-50-1.)

Figure 80-50-5

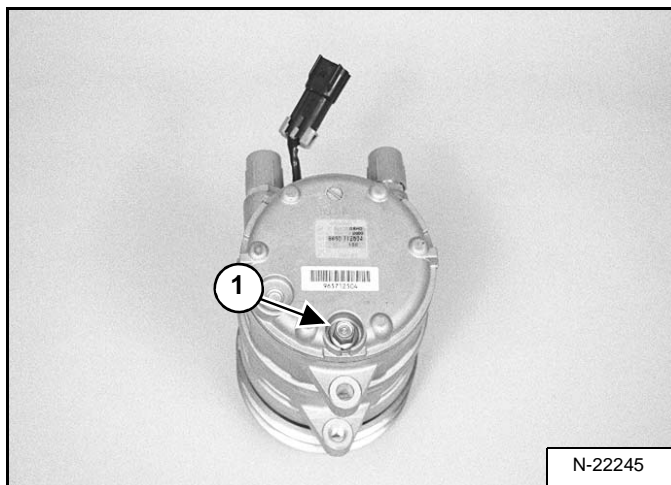
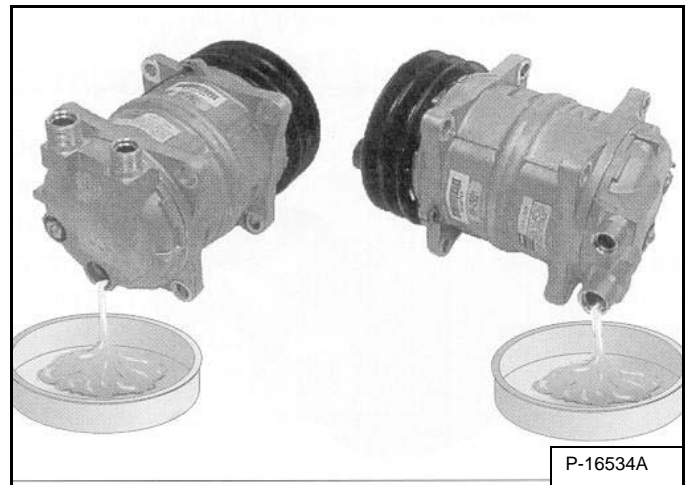

Figure 80-50-6



Remove the oil drain plug (Item 1) [Figure 80-50-5] and drain the oil through the connectors and the oil drain hole [Figure 80-50-6].

Installation: Tighten the oil drain plug to 13 - 15 N•m (9.4 - 10.8 ft-lb) torque.

Figure 80-50-7

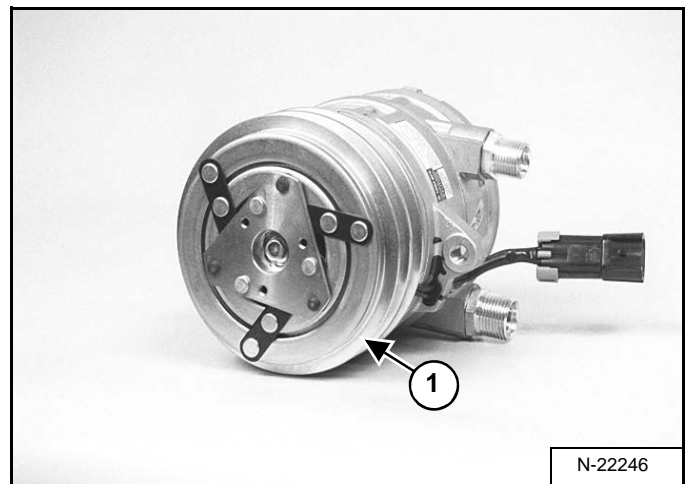

NOTE: After draining the oil through the drain hole and the connectors, extract the remaining oil through the discharge-side connector by rotating the drive pulley (Item 1) [Figure 80-50-7] several times by hand.

Measure the drained oil in a measuring cylinder.

Check the oil for contamination, dirt, metal shavings, or varnish color, discard the oil if contaminated.

NOTE: If metal shavings are found in the compressor oil, replace the complete compressor assembly.

RECEIVER / DRIER (CONT'D)

Schraeder Valve Removal And Installation

Figure 80-70-8

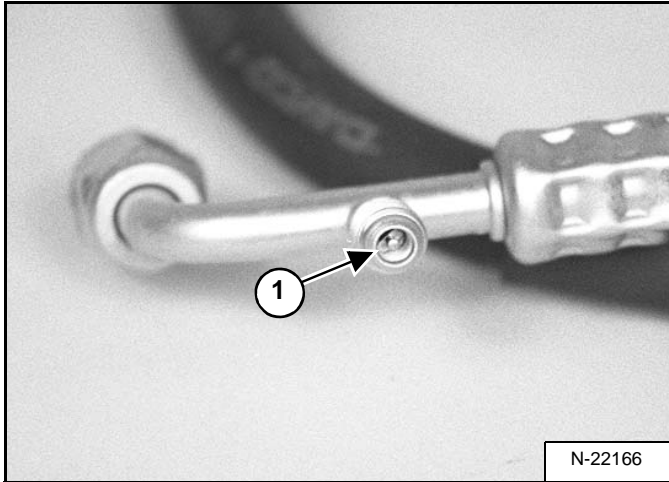

The schraeder valve (Item 1) **[Figure 80-70-8]** is located in the A/C high pressure hose and is located under the pressure switch.

Raise the loader lift arms and install an approved lift arm support device. (See Installing on Page 10-20-1.)

Raise the operator cab. (See Raising on Page 10-30-2.)

Remove the refrigerant from the A/C system. (See Reclamation And Charging With Recovery / Charging Unit on Page 80-40-2.)

Remove the pressure switch.

With a tire valve core removal tool, remove the valve core from the hose.

Replace with a new core.

HEATER COIL

Removal And Installation With A/C

Raise the lift arms and install an approved lift arm support device. (See Installing on Page 10-20-1.)

Raise the operator cab. (See Raising on Page 10-30-2.)

Remove the heater unit from the back of the cab. (See Removal And Installation on Page 80-80-1.)

Figure 80-120-1

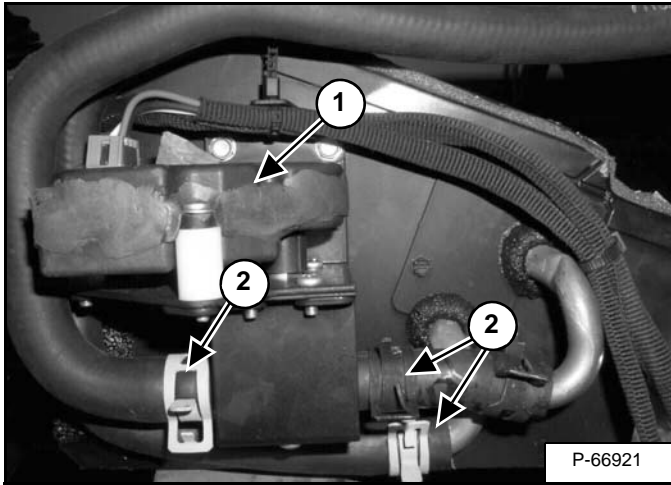

Remove the heater valve (Item 1) [Figure 80-120-1]. (See Removal And Installation on Page 80-140-1.)

Mark the heater hoses (Item 2) [Figure 80-120-1] for proper installation.

Cap the hoses and the heater coil with hydraulic caps and plugs to prevent oil loss from the system.

Remove the rear cover from the evaporator / heater unit. (See Removal And Installation on Page 80-80-1.)

Figure 80-120-2

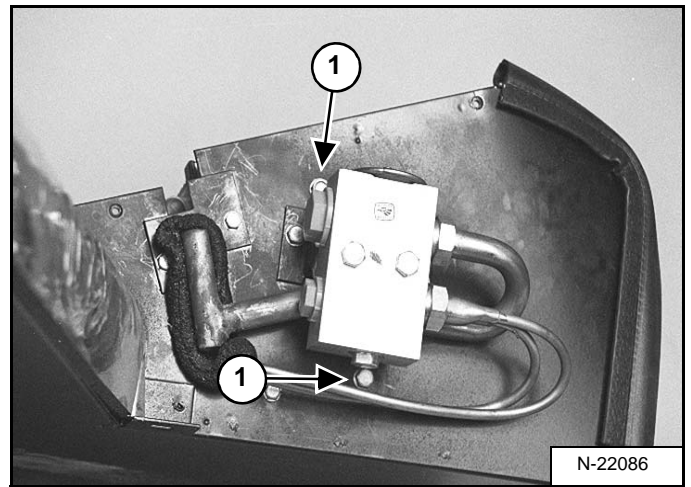

Remove the rear cover from the evaporator / heater unit. (See Removal And Installation on Page 80-80-1.)

Remove the two mount bolts (Item 1) [Figure 80-120-2] from the heater coil at the expansion valve end of the unit.

Figure 80-120-3

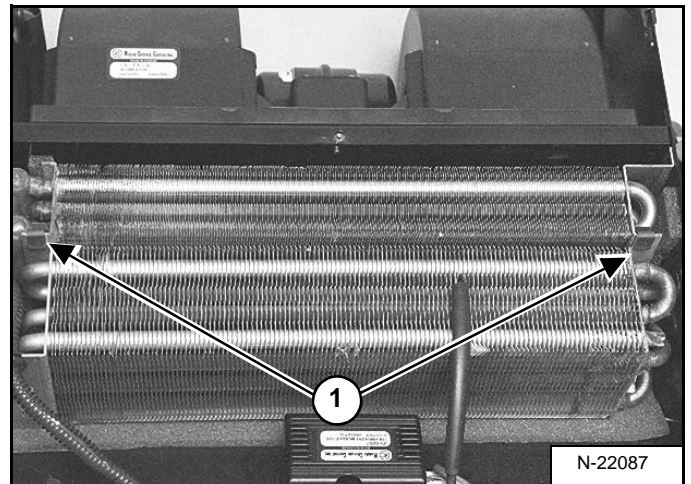

Remove the two retaining clips (Item 1) [Figure 80-120-3] that connect the evaporator coil, to the heater coil.

SPECIFICATIONS

CONVERSIONS	SPEC-50-1
Decimal And Millimeter Equivalent Chart	SPEC-50-1
U.S. To Metric Conversion Chart	SPEC-50-1
HYDRAULIC CONNECTION SPECIFICATIONS	SPEC-30-1
Flare Fitting	SPEC-30-3
O-ring Face Seal Connection	SPEC-30-1
Port Seal Fitting	SPEC-30-4
Straight Thread O-ring Fitting	SPEC-30-2
Tubelines And Hoses	SPEC-30-2
HYDRAULIC / HYDROSTATIC FLUID SPECIFICATIONS	SPEC-40-1
Specifications	SPEC-40-1
(T300) LOADER SPECIFICATIONS	SPEC-10-1
Capacities	SPEC-10-4
Controls	SPEC-10-3
Machine Dimensions	SPEC-10-1
Drive System	SPEC-10-3
Electrical	SPEC-10-4
Engine	SPEC-10-3
Ground Pressure	SPEC-10-4
Hydraulic System	SPEC-10-2
Performance	SPEC-10-2
Tracks	SPEC-10-4
TORQUE SPECIFICATIONS FOR BOLTS	SPEC-20-1
Torque For General SAE Bolts	SPEC-20-1
Torque For General Metric Bolts	SPEC-20-2

TIGHTEN ALL HARDWARE PER SIZE TO GRADE 5 TORQUE (SEE STANDARD TORQUE SPECIFICATIONS FOR BOLTS, SECTION SPEC-01) UNLESS OTHERWISE SPECIFIED.

SPECIFICATIONS

SPECIFICATIONS SUBJECT TO CHANGE WITHOUT NOTICE AND STANDARD ITEMS MAY VARY.

**HYDRAULIC CONNECTION SPECIFICATIONS
(CONT'D)**

Flare Fitting

Figure SPEC-30-4

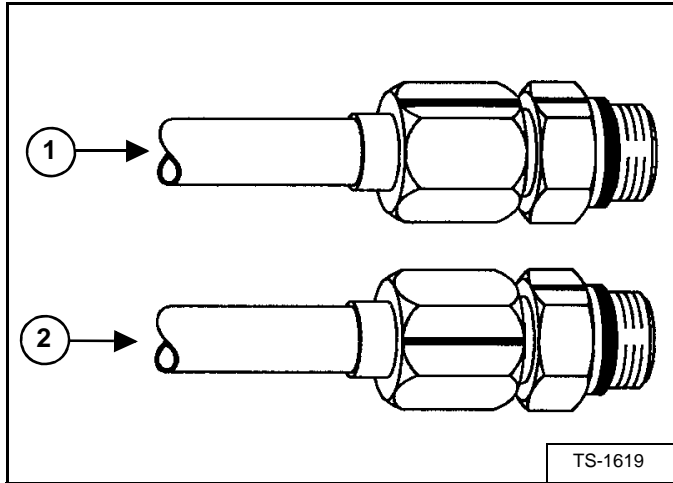

Use the following procedure to tighten the flare fitting:

Tighten the nut until it makes contact with the seat. Make a mark across the flats of both the male and female parts of the connection (Item 1) [Figure SPEC-30-4]

Use the chart [Figure SPEC-30-5] to find the correct tightness needed (Item 2) [Figure SPEC-30-4]. If the fitting leaks after tightening, disconnect it and inspect the seat area for damage.

Figure SPEC-30-5

Flare Fitting Tightening Torque		
Tubeline Outside Diameter	Thread Size	TORQUE N•m (ft-lb)
1/4"	7/16" - 20	18 (13)
5/16"	1/2" - 20	23 (17)
3/8"	9/16" - 18	30 (22)
1/2"	3/4" - 16	54 (40)
5/8"	7/8" - 14	81 (60)
3/4"	1-1/16" - 12	114 (84)
7/8"	1-3/16" - 12	133 (98)
1"	1-5/16" - 12	160 (118)
1-1/4"	1-5/8" - 12	209 (154)
1-1/2"	1-7/8" - 12	221 (163)
2"	2-1/2" - 12	342 (252)



SERVICE MANUAL REVISION

ROUTE TO ATTENTION

PARTS MANAGER	<input type="checkbox"/>
SERVICE MANAGER	<input checked="" type="checkbox"/>
SALES MANAGER	<input type="checkbox"/>

NOTICE

Insert This Sheet With The Below Listed Manual For Future Reference.

Revision No: T300 - 3
Date: 15 October 2008
Product: Bobcat Loader
Model: T300
Manual No: 6987045 (10-08)

The following Sections are a revision to the above Service Manual.

COVER

10-180

20-01

20-40

20-41

40-20

40-21

50-01

50-130

ELECTRICAL SCHEMATICS

60-161

CLICK HERE TO **DOWNLOAD** THE COMPLETE MANUAL

- Thank you very much for reading the preview of the manual.
- You can download the complete manual from: www.heydownloads.com by clicking the link below



- Please note: If there is no response to CLICKING the link, please download this PDF first and then click on it.

CLICK HERE TO **DOWNLOAD** THE COMPLETE MANUAL