

T200
TURBO

T200
TURBO
HIGH FLOW



Bobcat®

Service Manual

S/N 518915001 & Above
S/N 516815001 & Above
S/N 517515001 & Above

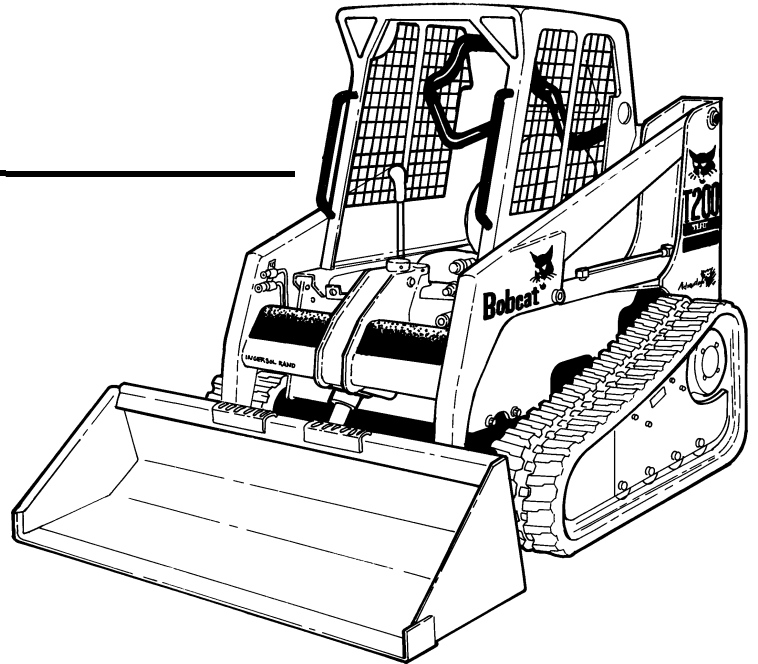

EQUIPPED WITH
BOBCAT INTERLOCK
CONTROL SYSTEM (BICS™)

CLICK HERE TO **DOWNLOAD** THE COMPLETE MANUAL

- Thank you very much for reading the preview of the manual.
- You can download the complete manual from: www.heydownloads.com by clicking the link below



- Please note: If there is no response to CLICKING the link, please download this PDF first and then click on it.

CLICK HERE TO **DOWNLOAD** THE COMPLETE MANUAL

SAFETY INSTRUCTIONS



Safety Alert Symbol

This symbol with a warning statement means: "Warning, be alert! Your safety is involved!" Carefully read the message that follows.



WARNING

Instructions are necessary before operating or servicing machine. Read and understand the Operation & Maintenance Manual, Operator's Handbook and signs (decals) on machine. Follow warnings and instructions in the manuals when making repairs, adjustments or servicing. Check for correct function after adjustments, repairs or service. Untrained operators and failure to follow instructions can cause injury or death.

W-2003-0903

IMPORTANT

This notice identifies procedures which must be followed to avoid damage to the machine.

I-2019-0284



DANGER

The signal word DANGER on the machine and in the manuals indicates a hazardous situation which, if not avoided, will result in death or serious injury.

D-1002-1107



WARNING

The signal word WARNING on the machine and in the manuals indicates a potentially hazardous situation which, if not avoided, could result in death or serious injury.

W-2044-1107

The following publications provide information on the safe use and maintenance of the Bobcat machine and attachments:

- The Delivery Report is used to assure that complete instructions have been given to the new owner and that the machine is in safe operating condition.
- The Operation & Maintenance Manual delivered with the machine or attachment contains operating information as well as routine maintenance and service procedures. It is a part of the machine and can be stored in a container provided on the machine. Replacement Operation & Maintenance Manuals can be ordered from your Bobcat dealer.
- Machine signs (decals) instruct on the safe operation and care of your Bobcat machine or attachment. The signs and their locations are shown in the Operation & Maintenance Manual. Replacement signs are available from your Bobcat dealer.
- An Operator's Handbook fastened to the operator cab. It's brief instructions are convenient to the operator. The handbook is available from your dealer in an English edition or one of many other languages. See your Bobcat dealer for more information on translated versions.
- The AEM Safety Manual delivered with the machine gives general safety information.
- The Service Manual and Parts Manual are available from your dealer for use by mechanics to do shop-type service and repair work.
- The Skid-Steer Loader Operator Training Course is available through your local dealer or at www.training.bobcat.com or www.bobcat.com. This course is intended to provide rules and practices of correct operation of the Skid-Steer Loader. The course is available in English and Spanish versions.
- Service Safety Training Courses are available from your Bobcat dealer or at www.training.bobcat.com or www.bobcat.com. They provide information for safe and correct service procedures.
- The Skid-Steer Loader Safety Video is available from your Bobcat dealer or at www.training.bobcat.com or www.bobcat.com.

SI SSL-1008 SM

**T200 Bobcat Loader
Service Manual**

LIFTING AND BLOCKING THE LOADER



Instructions are necessary before operating or servicing machine. Read and understand the Operation & Maintenance Manual and signs (decals) on machine. Follow warnings and instructions in the manuals when making repairs, adjustments or servicing. Check for correct function after adjustments, repairs or service. Untrained operators and failure to follow instructions can cause injury or death.

W-2408-0801

Figure 10-10-1

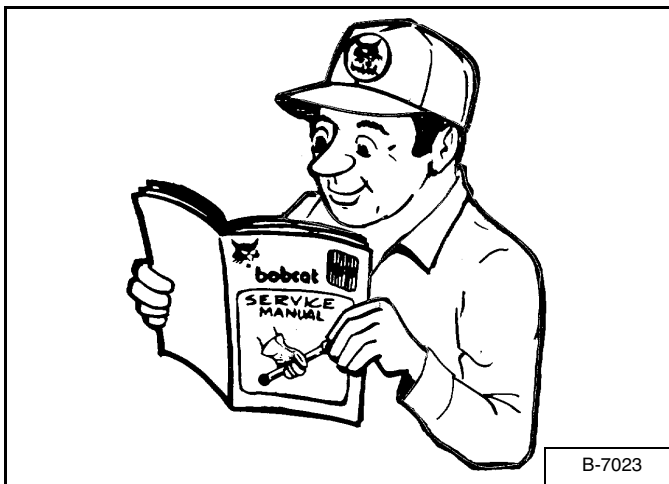

Read the Removal & Installation, Disassembly & Assembly, etc. completely to become familiar with the procedure before beginning [Figure 10-10-1].

Procedure

Always park the loader on a level surface.



Put jackstands under the front axles and rear corners of the frame before running the engine for service. Failure to use jackstands can allow the machine to fall or move and cause injury or death.

W-2017-0286

Figure 10-10-2



P-24728

Put floor jack under the rear of the loader [Figure 10-10-2]

Lift the rear of the loader and install jackstands [Figure 10-10-2].

Figure 10-10-3

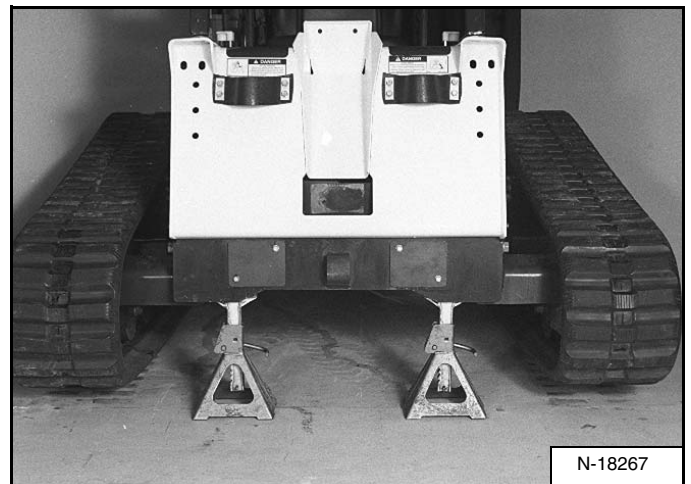

N-18267

Put the floor jack under the front of the loader [Figure 10-10-3].

Lift the front of the loader and put jackstands under the loader frame [Figure 10-10-3].

NOTE: Make sure the jackstands do not touch the tracks. Make sure tracks clear floor or any obstacles.

TRANSPORTING THE BOBCAT LOADER

Procedure



AVOID SERIOUS INJURY OR DEATH

Adequately designed ramps of sufficient strength are needed to support the weight of the machine when loading onto a transport vehicle. Wood ramps can break and cause personal injury.

W-2058-0807

Figure 10-40-1

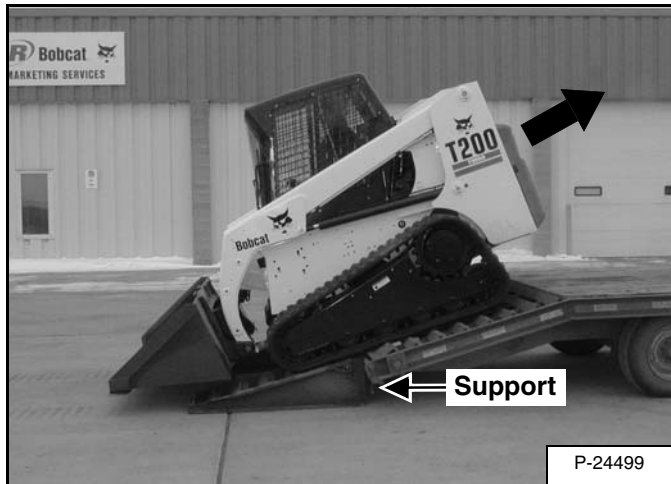

Always drive backward onto the transport vehicle [Figure 10-40-1] when the loader has an empty bucket or no attachment.

The rear of the trailer must be blocked or supported [Figure 10-40-1] when loading or unloading the loader to prevent the front end of the trailer from raising up.

Be sure the transport and towing vehicles are of adequate size and capacity. (See Loader Dimensions on Page SPEC-10-1.)

Figure 10-40-2

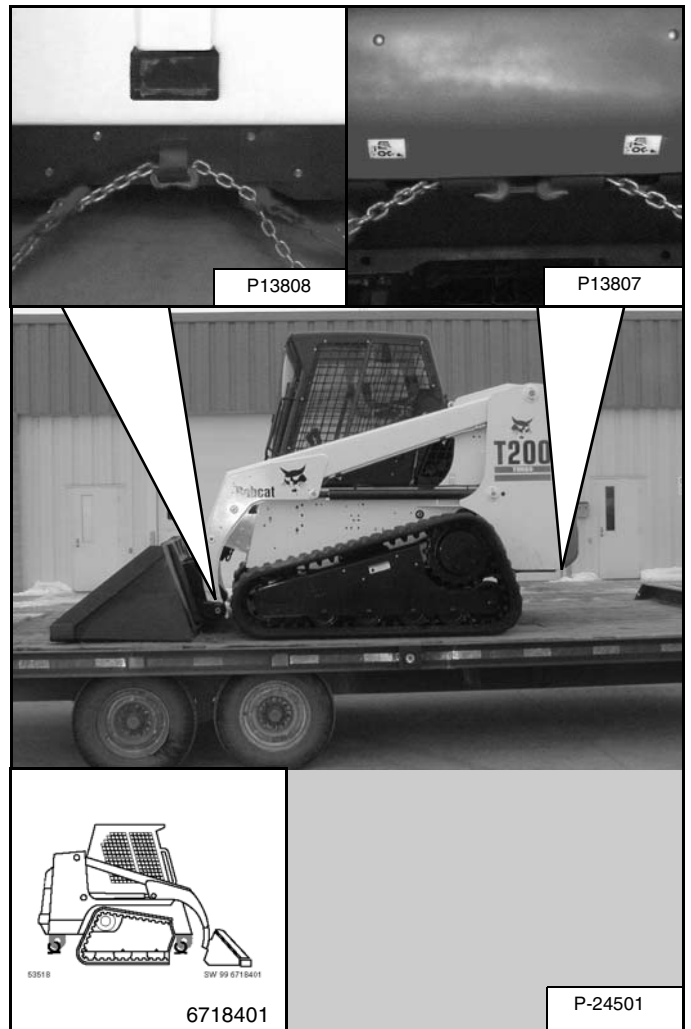

Fasten the Bobcat loader to the transport vehicle to prevent the loader from moving during sudden stops or when going up or down slopes [Figure 10-40-2].

- Lower the bucket or attachment to the floor.
- Stop the engine and engage the parking brake.
- Install chains at the front and rear loader tie down positions (inset) [Figure 10-40-2].
- Fasten each end of the chain diagonally to the transport vehicle.
- Install load binders to tighten the chains.

Stopping The Bobcat Loader

Put the steering levers in neutral.

The hydrostatic transmission will act as a *service brake* to stop the loader.

SERVICE SCHEDULE

Chart

Maintenance work must be done at regular intervals. Failure to do so will result in excessive wear and early failures. The service schedule is a guide for correct maintenance of the Bobcat loader.



Instructions are necessary before operating or servicing machine. Read and understand the Operation & Maintenance Manual, Handbook and signs (decals) on machine. Follow warnings and instructions in the manuals when making repairs, adjustments or servicing. Check for correct function after adjustments, repairs or service. Untrained operators and failure to follow instructions can cause injury or death.

W-2003-0199

| SERVICE SCHEDULE | | HOURS | | | | | |
|--|--|-------|----|-----|-----|------|------|
| ITEM | SERVICE REQUIRED | 8-10 | 50 | 250 | 500 | 1000 | 3000 |
| Engine Oil | Check the oil level and add as needed. | | | | | | |
| Engine Air Filter and Air System | Check display panel. Service only when required. Check for leaks and damaged components. | | | | | | |
| Engine Cooling System | Clean debris from oil cooler, radiator & grill. | | | | | | |
| Lift Arms, Cylinders, Bob-Tach Pivot Pins and Wedges | Lubricate with multi-purpose lithium based grease (12 places). | | | | | | |
| Seat Bar, Control Interlocks, Seat Belt, Seat Belt Retractors | Check the condition of seat belt. Clean or replace seat belt retractors as needed. Check the seat bar and control interlocks for correct operation. Clean dirt and debris from moving parts. | | | | | | |
| Bobcat Interlock Control Systems (BICS™) | Check BICS™ functions. | | | | | | |
| Safety Signs and Safety Treads | Check for damaged signs (decals) and safety treads. Replace any signs or safety treads that are damaged or worn. | | | | | | |
| Operator Cab | Check the fastening bolts, washers and nuts. Check the condition of the cab. | | | | | | |
| Indicators and Lights | Check for correct operation of all indicators and lights. | | | | | | |
| Fuel Filter | Remove the trapped water. | | | | | | |
| Tracks | Check for damaged tracks and correct tension. Adjust as needed. | ¥ | | | | | |
| Hydraulic Fluid, Hoses and Tubelines | Check fluid level and add as needed. Check for damage and leaks. Repair or replace as needed. | | | | | | |
| Battery | Check cables, connections and electrolyte level. Add distilled water as needed. | | | | | | |
| Foot Pedals or Hand Controls, and Steering Levers | Check for correct operation. Repair or adjust as needed. | | | | | | |
| Parking Brake | Check operation. | | | | | | |
| Alternator Belt | Check tension and adjust as needed. | | | | | | |
| Engine / Hydro. Drive Belt | *Check for wear or damage. Check idler arm stop. | | | | | | |
| Fuel Filter | Replace filter element. | | | | | | |
| Steering Shaft | Grease three fittings. | | | | | | |
| Hydraulic Reservoir Breather Cap | Replace the reservoir breather cap. | | | ○ | | | |
| Hyd. / Hydro. Filter | ●Replace the filter element. | | | | | | |
| Engine Oil and Filter | Replace oil and filter. Use CD or better grade oil and Bobcat filter. | | ^ | ○ | | | |
| Hydraulic Reservoir | Clean or replace the fluid. | | | | | | |
| Hydrostatic Motors | Clean or replace the case drain filters. | | | | | | |
| Hydrostatic Motor Carrier | Replace oil. Use SAE 10W-40. | | | | | | |
| Bobcat Interlock Control System (BICS™) | Check lift arm bypass control. | | | | | | |
| Fan Drive Gearbox | Check gear lube level. | | | | | | |
| Engine Valves | Adjust the engine valves. | | | | # | | |
| Track Rollers and Idlers | Replace oil. Use SAE 10W-40. (Rollers-70cc, Idlers-100cc) | | | | | | |
| Engine Timing Belt | Replace the timing belt and belt tensioner assy. | | | | | | ▼ |

● Also replace hydraulic / hydrostatic filter element when the transmission warning light comes ON.

■ Or every 12 months.

* Inspect the new belt after the first 50 hours.

^ First oil and filter change must occur at 50 hours; 500 hours thereafter.

○ When operating under severe conditions, change oil and filter every 250 hours.

After the first 500 hours on new engine, adjust engine valves; 1000 hours thereafter. (See Service Manual for procedure.)

▼ Or every 5 years.

¥ Check every 8-10 hours for the first 50 hours. Then at 50 hour intervals.

ENGINE LUBRICATION SYSTEM

Checking Engine Oil

Figure 10-110-1

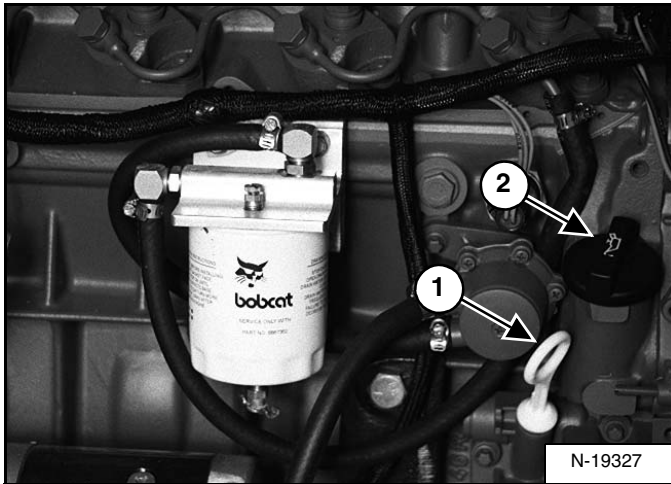

Check the engine oil level every day.

Before starting the engine for the work shift, open the rear door. Remove the dipstick (Item 1) [Figure 10-110-1].

Keep the oil level between the marks on the dipstick.

Use a good quality motor oil that meets API Service Classification of CD, CE or better. (See Oil Chart below.)

RECOMMENDED SAE VISCOSITY NUMBER C° (LUBRICATION OILS FOR DIESEL ENGINE CRANKCASE)

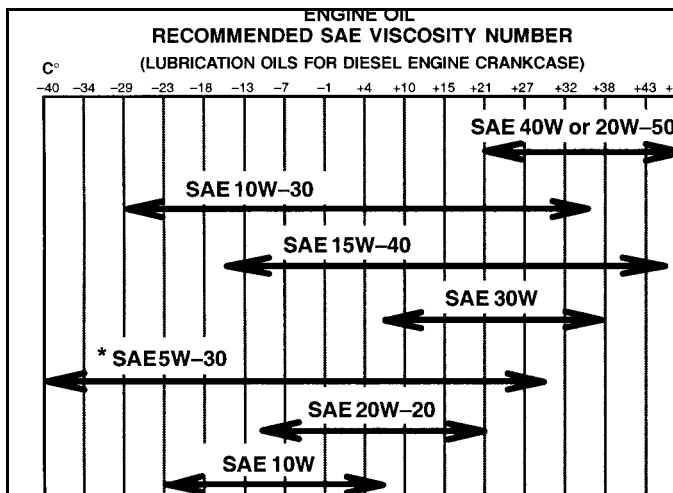

TEMPERATURE RANGE ANTICIPATED
BEFORE NEXT OIL CHANGE (DIESEL ENGINES MUST
USE API CLASSIFICATION CD, CF4, CG4)

* Can be used **ONLY** when available with appropriate diesel rating.

POWER BOB-TACH (OPTION)

Inspection And Maintenance

Figure 10-141-1

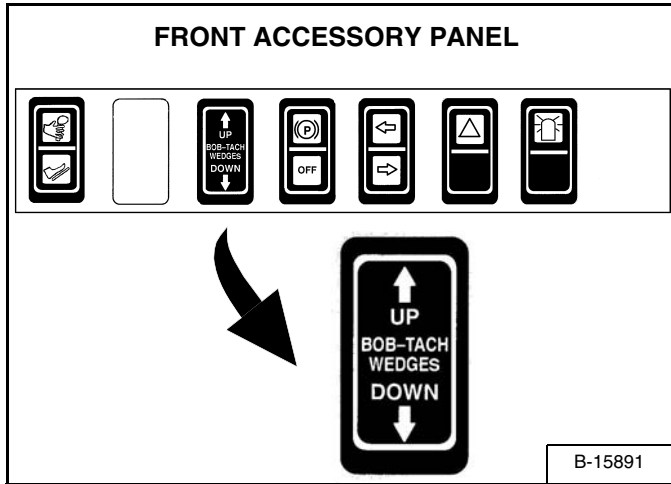

Push and hold the BOB-TACH “WEDGES UP” switch [Figure 10-141-1] until wedges are fully raised. Push and hold the BOB-TACH “WEDGES DOWN” switch [Figure 10-141-1] until the wedges are fully down. The wedges must move freely.

Figure 10-141-2

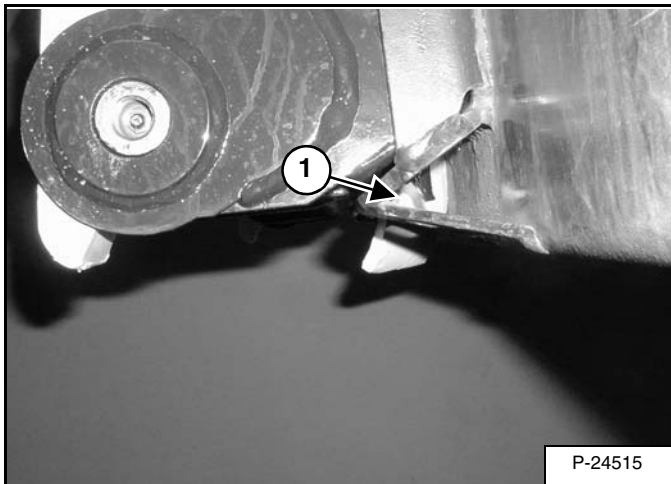

The wedges must extend through the holes in the attachment mounting frame (Item 1) [Figure 10-141-2] and must contact the lower edge of the hole in the attachment [Figure 10-141-2] and (Item 1) [Figure 10-141-3].

Figure 10-141-3

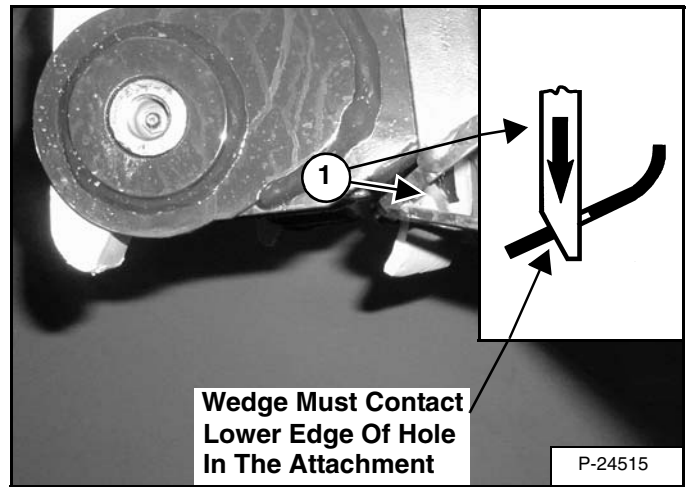

If the wedge does not contact the lower edge of the hole [Figure 10-141-3], the attachment will be loose and can come off the Bob-Tach.

Figure 10-141-4

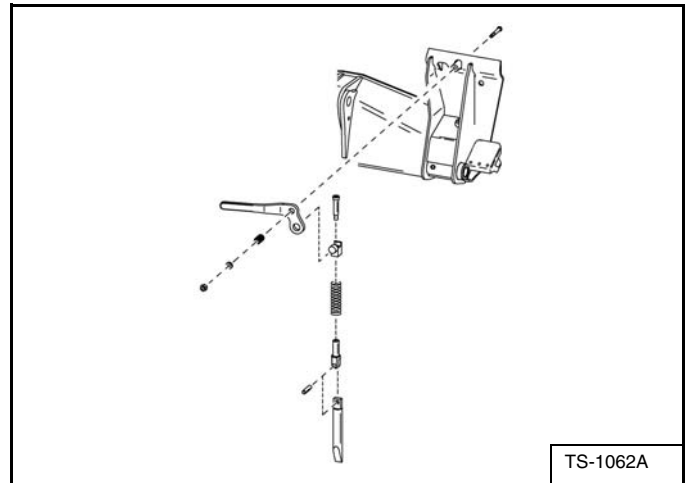

Inspect the mounting frame on the attachment and the Bob-Tach, linkages and wedges for excessive wear or damage [Figure 10-141-4] Replace any parts including decals and lever that are damaged, bent, or missing. Keep all fasteners tight. Inspect the hoses and fittings for leaks.

Look for cracked welds. Contact your Bobcat dealer for repair or replacement parts.

Lubricate the wedges. (See SERVICE SCHEDULE on Page 10-70-1, and See Inspection And Maintenance on Page 10-141-1)

T200 HYDRAULIC/HYDROSTATIC SCHEMATIC

S/N 518915001 - 518916010

S/N 516815001 - 516815094

(PRINTED OCTOBER 2002)

V-0075legend

LEGEND

- | | | | |
|--|--|--|--|
| ① RESERVOIR: Capacity 18.8 Qts. (17.8 L) | ⑩ PILOTED ACTIVATED DIRECTIONAL CONTROL VALVE - FLOW CONTROL SPOOL | ③① DRIVE MOTOR SHUTTLE VALVE | ④⑤ VARIABLE CAPACITY DISPLACEMENT BIDIRECTIONAL HYDROSTATIC PUMP |
| ② FILTER - CASE DRAIN (90 Micron) | ⑪ PILOTED ACTIVATED DIRECTIONAL CONTROL VALVE - UNLOADING SPOOL | ③② SHUTTLE RELIEF VALVE: 200 PSI (1378 kPa) | ④⑥ RESTRICTION - 0.020 inch (0,5 mm) |
| ③ FILTER - HYDRAULIC (CANISTER) | ⑫ PILOTED ACTIVATED DIRECTIONAL CONTROL VALVE - TILT CONTROL | ③③ SOLENOID ACTIVATED DIRECTIONAL CONTROL VALVE - BLEED OFF REAR AUXILIARY ("SV2") | ④⑦ SOLENOID ACTIVATED DIRECTIONAL CONTROL VALVE (TWO COIL) |
| ④ SPRING LOADED FILTER BYPASS VALVE: 45-55 PSI (311-379 kPa) | ⑬ PILOTED ACTIVATED DIRECTIONAL CONTROL VALVE - LIFT CONTROL | ③④ LOAD SHUTTLE VALVE - BLEED OFF | ④⑧ RELIEF VALVE - 1200 PSI (8268 kPa) |
| ⑤ PILOT ACTIVATED DIRECTIONAL CONTROL VALVE - HYDRAULIC POWERED BOB-TACH | ⑭ SOLENOID ACTIVATED DIRECTIONAL CONTROL VALVE - BICS CONTROL | ③⑤ PILOT ACTIVATED DIRECTIONAL CONTROL VALVE - FOR REAR AUXILIARY - NORMALLY CLOSED ("P2" and "F2") | ④⑨ RESTRICTION - 0.090 inch (2,3 mm) |
| ⑥ DIFFERENTIAL PRESSURE SWITCH: 36-44 PSI (248-303 kPa) | ⑮ PULL BUTTON ACTIVATED DIRECTIONAL CONTROL VALVE - LIFT ARM BY PASS | ③⑥ PILOT ACTIVATED DIRECTIONAL CONTROL VALVE - FOR REAR AUXILIARY - NORMALLY OPEN ("D1" and "P1") | ⑤① RELIEF VALVE - PORT: 3500 PSI (24132 kPa) |
| ⑦ FLOW DIVIDER ADJUSTMENT VALVE | | ③⑦ PILOT ACTIVATED DIRECTIONAL CONTROL VALVE - FOR REAR AUXILIARY - NORMALLY OPEN ("D2" and "P2") | ⑤② SOLENOID ACTIVATED DIRECTIONAL CONTROL VALVE - BUCKET POSITION VALVE (ON/OFF) |
| ⑧ CHECK VALVE - BUCKET POSITION VALVE | | ③⑧ FILTER - DIVERTER VALVE (SCREEN) INTEGRATED IN SOLENOID | ⑤③ HYDRAULIC BRAKE - SPRING APPLIED - |
| ⑨ FIXED CAPACITY DISPLACEMENT BIDIRECTIONAL HYDROSTATIC MOTOR | | ③⑨ SOLENOID ACTIVATED DIRECTIONAL CONTROL VALVE - TO ACTIVATE REAR AUXILIARY ("SV1") | ⑤④ PRESSURE TO RELEASE PUSH BUTTON SOLENOID ACTIVATED DIRECTIONAL CONTROL VALVE - BRAKE |
| ⑫ FILTER - BICS CONTROL VALVE (SCREEN) | | ④① CHECK VALVE - BICS CONTROL VALVE | ⑤⑤ SCREEN |
| ⑬ ONE WAY RESTRICTOR | | ④② RESTRICTION | ⑤⑥ ACCUMULATOR |
| ⑭ LOAD CHECK VALVE | | ④③ CHECK VALVE - AUXILIARY | |
| ⑮ RELIEF VALVE - MAIN: 2950-3050 PSI (20340-21030 kPa) at Front Quick Couplers | | *④④ MUFFLER (If Equipped) | |
| ⑯ RELIEF VALVE - PORT: 3500 PSI (24132 kPa) | | | |
| ⑰ ANTICAVITATION VALVE | | | |
| ⑱ RELIEF/ANTICAVITATION VALVE - PORT (TILT BASE END) 3500 PSI (24132 kPa) | | | |
| ⑳ ONE WAY RESTRICTOR VALVE | | | |
| ㉑ SOLENOID ACTIVATED DIRECTIONAL CONTROL VALVE - AUXILIARY | | | |
| ㉒ RELIEF VALVE - PORT: (Optional) 3500 PSI (24132 kPa) | | | |
| ㉓ RELIEF/REPLENISHING VALVE - HIGH PRESSURE: 5000 PSI (34470 kPa) | | | |
| ㉔ PRESSURE SWITCH | | | |
| ㉕ RELIEF VALVE - CHARGE: 120 degrees F. (53 degrees C.)Fluid at 1775 Pump RPM 400 - 420 PSI (2756 - 2894 kPa) | | | |
| ㉖ CHARGE PUMP 11.0 GPM (41,6 L/min.) at 2615 Engine RPM | | | |
| ㉗ HYDRAULIC PUMP Gear Type 19.2 GPM (113,6 L/min.) at 2615 Engine RPM | | | |

NOTE: Unless otherwise specified
springs have NO significant
pressure value.

**T200 HYDRAULIC/HYDROSTATIC SCHEMATIC
WITH HIGH FLOW OPTION
S/N 518916428 - 518917134
S/N 517515147 - 517515202
(PRINTED OCTOBER 2002)
V-0223legend**

LEGEND

- | | | | |
|---|--|---|---|
| <p>① RESERVOIR: Capacity 18.8 Qts. (17.8 L)</p> <p>② FILTER - CASE DRAIN (90 Micron)</p> <p>③ FILTER - HYDRAULIC (CANISTER)</p> <p>④ SPRING LOADED FILTER BYPASS VALVE: 45-55 PSI (311-379 kPa)</p> <p>⑤ PILOT ACTIVATED DIRECTIONAL CONTROL VALVE - HYDRAULIC POWERED BOB-TACH</p> <p>⑥ DIFFERENTIAL PRESSURE SWITCH: 36-44 PSI (248-303 kPa)</p> <p>⑦ FLOW DIVIDER ADJUSTMENT VALVE</p> <p>⑧ CHECK VALVE - BUCKET POSITION VALVE</p> <p>⑨ FIXED CAPACITY DISPLACEMENT BIDIRECTIONAL HYDROSTATIC MOTOR</p> <p>⑩ PILOTED ACTIVATED DIRECTIONAL CONTROL VALVE - FLOW CONTROL SPOOL</p> <p>⑪ PILOTED ACTIVATED DIRECTIONAL CONTROL VALVE - UNLOADING SPOOL</p> <p>⑫ PILOTED ACTIVATED DIRECTIONAL CONTROL VALVE - TILT CONTROL</p> <p>⑬ PILOTED ACTIVATED DIRECTIONAL CONTROL VALVE - LIFT CONTROL</p> <p>⑭ SOLENOID ACTIVATED DIRECTIONAL CONTROL VALVE - BICS CONTROL</p> <p>⑮ PULL BUTTON ACTIVATED DIRECTIONAL CONTROL VALVE - LIFT ARM BY PASS</p> | <p>⑯ FILTER - BICS CONTROL VALVE (SCREEN)</p> <p>⑰ ONE WAY RESTRICTOR</p> <p>⑱ LOAD CHECK VALVE</p> <p>⑲ RELIEF VALVE - MAIN: 2950-3050 PSI (20340-21030 kPa) at Front Quick Couplers</p> <p>⑳ RELIEF VALVE - PORT: 3500 PSI (24132 kPa)</p> <p>㉑ ANTICAVITATION VALVE</p> <p>㉒ RELIEF/ANTICAVITATION VALVE - PORT (TILT BASE END) 3500 PSI (24132 kPa)</p> <p>㉓ ONE WAY RESTRICTOR VALVE</p> <p>㉔ SOLENOID ACTIVATED DIRECTIONAL CONTROL VALVE - AUXILIARY</p> <p>㉕ RELIEF VALVE - PORT: (Optional) 3500 PSI (24132 kPa)</p> <p>㉖ RELIEF/REPLENISHING VALVE - HIGH PRESSURE: 5000 PSI (34470 kPa)</p> <p>㉗ PRESSURE SWITCH</p> <p>㉘ RELIEF VALVE - CHARGE: 120 degrees F. (53 degrees C.) Fluid at 1775 Pump RPM 400 - 420 PSI (2756 - 2894 kPa)</p> <p>㉙ CHARGE PUMP 11.0 GPM (41,6 L/min.) at 2615 Engine RPM</p> <p>㉚ HYDRAULIC PUMP Gear Type 19.2 GPM (72,7 L/min.) at 2615 Engine RPM HIGH FLOW CAPACITY: (Includes ⑤⑤) 30.0 GPM (113,6 L/min.) at 2615 Engine RPM</p> | <p>⑳ DRIVE MOTOR SHUTTLE VALVE</p> <p>㉑ SHUTTLE RELIEF VALVE: 200 PSI (1378 kPa)</p> <p>㉒ SOLENOID ACTIVATED DIRECTIONAL CONTROL VALVE - BLEED OFF REAR AUXILIARY ("SV2")</p> <p>㉓ LOAD SHUTTLE VALVE - BLEED OFF</p> <p>㉔ PILOT ACTIVATED DIRECTIONAL CONTROL VALVE - FOR REAR AUXILIARY - NORMALLY CLOSED ("P2" and "F2")</p> <p>㉕ PILOT ACTIVATED DIRECTIONAL CONTROL VALVE - FOR REAR AUXILIARY - NORMALLY OPEN ("D1" and "P1")</p> <p>㉖ PILOT ACTIVATED DIRECTIONAL CONTROL VALVE - FOR REAR AUXILIARY - NORMALLY OPEN ("D2" and "P2")</p> <p>㉗ FILTER - DIVERTER VALVE (SCREEN) INTEGRATED IN SOLENOID</p> <p>㉘ SOLENOID ACTIVATED DIRECTIONAL CONTROL VALVE - TO ACTIVATE REAR AUXILIARY ("SV1")</p> <p>㉙ PILOT ACTIVATED DIRECTIONAL CONTROL VALVE - FOR REAR AUXILIARY - NORMALLY CLOSED ("P1" and "F1")</p> <p>㉚ CHECK VALVE - BICS CONTROL VALVE</p> <p>㉛ RESTRICTION</p> <p>㉜ CHECK VALVE - AUXILIARY</p> <p>* ㉝ MUFFLER (If Equipped)</p> <p>㉞ VARIABLE CAPACITY DISPLACEMENT BIDIRECTIONAL HYDROSTATIC PUMP</p> | <p>④⑥ TWO STAGE RELIEF 1000 PSI/2000 PSI (6894kPa/13788 kPa)</p> <p>④⑦ SOLENOID ACTIVATED DIRECTIONAL CONTROL VALVE (TWO COIL)</p> <p>④⑧ RELIEF VALVE - 1200 PSI (8268 kPa)</p> <p>④⑨ PRESSURE COMPENSATED FLOW CONTROL</p> <p>④⑩ CHECK VALVE WITH 0.015 (0,38 mm) RESTRICTION</p> <p>④⑪ RELIEF VALVE - PORT: 3500 PSI (24132 kPa)</p> <p>④⑫ SOLENOID ACTIVATED DIRECTIONAL CONTROL VALVE - BUCKET POSITION VALVE (ON/OFF)</p> <p>④⑬ HYDRAULIC BRAKE - SPRING APPLIED - PRESSURE TO RELEASE</p> <p>④⑭ PUSH BUTTON SOLENOID ACTIVATED DIRECTIONAL CONTROL VALVE - BRAKE</p> <p>④⑮ AUXILIARY HYDRAULIC PUMP: PUMP CAPACITY: 10.8 GPM (40,9 L/min.) at 2750 RPM</p> <p>④⑯ RELIEF VALVE - 3300 PSI (22754 kPa)</p> <p>④⑰ FILTER - CASE DRAIN (Attachment)</p> <p>④⑱ FRONT AUXILIARY MANUAL PRESSURE BLEED-OFF VALVE</p> <p>④㉑ DUMP VALVE (ON/OFF)</p> <p>④㉒ CHECK VALVE</p> |
|---|--|---|---|

NOTE: Unless otherwise specified springs have NO significant pressure value.

HYDRAULIC SYSTEM INFORMATION (CONT'D)

Troubleshooting

The Following Troubleshooting Chart Is Provided For Assistance In Locating And Correcting Problems Which Are Most Common. Many Of The Recommended Procedures Must Be Done By Authorized Bobcat Service Personnel Only.



Check for correct function after adjustments, repairs or service. Failure to make correct repairs or adjustments can cause injury or death.

W-2004-1285

| PROBLEM | CAUSE |
|--|------------------------|
| The hydraulic system will not operate. | 1, 2, 3, 5, 8 |
| The transmission warning light comes ON when hydraulics are operating. | 1, 3, |
| Slow hydraulic system action. | 1, 3, 4, 6, 8 |
| Hydraulic action is not smooth. | 1, 4, 5, 6, 7 |
| Lift arms go up slowly at full engine RPM. | 1, 3, 4, 5, 6, 7, 8, 9 |
| The lift arms or Bob-Tach will move when the pedal is in neutral position. | 4 |
| The lift arms come down with the pedal in the neutral position. | 4, 9, 10, 11 |
| Bypass valve stuck. | 12 |
| Bypass valve stem bent or broke. | 13 |

| KEY TO CORRECT THE CAUSE |
|--|
| 1. The fluid level is not correct. |
| 2. The pedal linkage is disconnected. |
| 3. The hydraulic pump has damage. |
| 4. The pedal linkage is not adjusted correctly. |
| 5. Relief valve is not at the correct pressure. |
| 6. Suction leak on the inlet side of the hydraulic pump. |
| 7. Fluid is cold. Wrong viscosity fluid. (See HYDRAULIC/HYDROSTATIC FLUID SPECIFICATIONS on Page SPEC-60-1.) |
| 8. Using the loader for more than its rated capacity. |
| 9. Internal leak in the lift cylinder(s). |
| 10. External leak from the lift cylinder(s). |
| 11. Damaged lift spool. |
| 12. Rotate shaft. |
| 13. Replace manual spool cartridge. |

CYLINDER (TILT)

Checking

Remove the attachment. Roll the Bob-Tach fully back. Stop the engine. Raise the seat bar.



AVOID INJURY OR DEATH

Diesel fuel or hydraulic fluid under pressure can penetrate skin or eyes, causing serious injury or death. Fluid leaks under pressure may not be visible. Use a piece of cardboard or wood to find leaks. Do not use your bare hand. Wear safety goggles. If fluid enters skin or eyes, get immediate medical attention from a physician familiar with this injury.

W-2072-0807

Figure 20-21-1

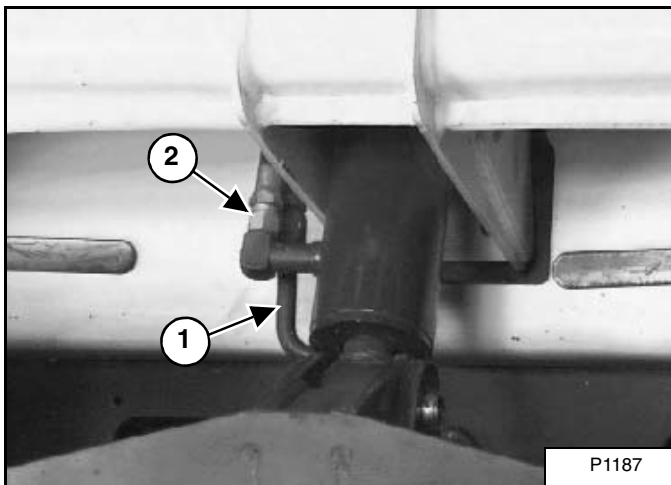

Disconnect the hose (Item 1) [Figure 20-21-1] which goes to the base end of the tilt cylinder.

Put a plug in the hose and tighten.

Install a test hose between cylinder and drain pan.

Engage the parking brake. Lower the seat bar. Start the engine and push the bottom (heel) of the tilt pedal. If there is leakage from the open port, remove the tilt cylinder for repair.

Removal And Installation

Figure 20-21-2



Remove the attachment. Roll the Bob-Tach fully forward [Figure 20-21-2] on blocks.

Stop the engine.

Figure 20-21-3

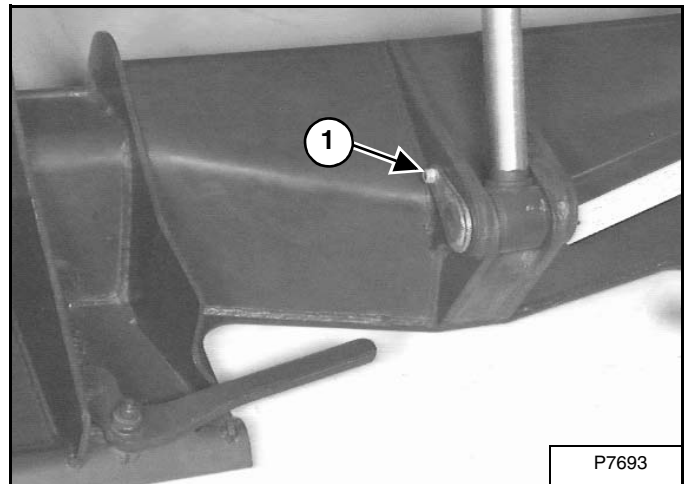

Raise the seat bar. Remove the retainer bolt and nut (Item 1) [Figure 20-21-3] from the rod end pivot pin.

Installation: Tighten the retainer nut to 18 - 20 ft.-lb. (24 - 27 N•m) torque.

CYLINDER (POWER BOB-TACH)

Checking

Figure 20-22-1

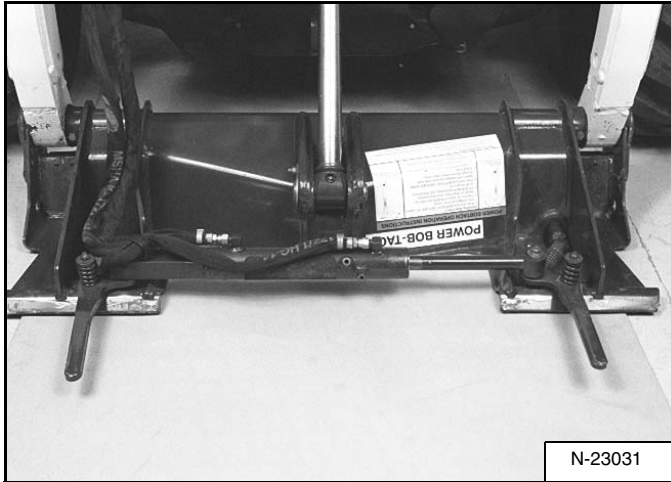

Tilt the Bob-Tach forward, so it is parallel to the floor [Figure 20-22-1].

Figure 20-22-2

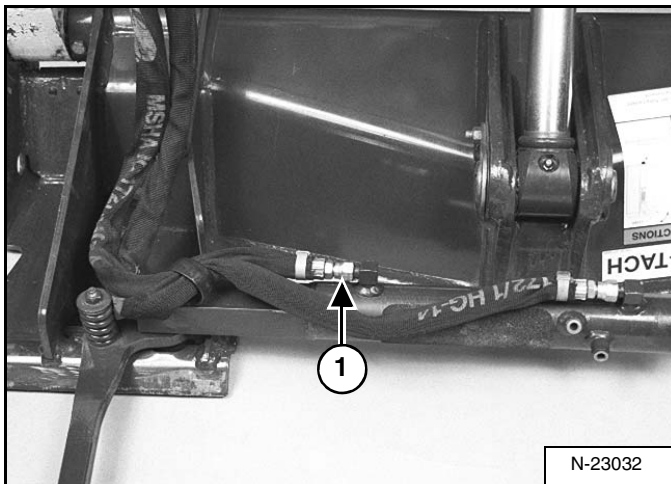

Disconnect the hose (Item 1) [Figure 20-22-2] from the power Bob-Tach cylinder base end port.

Figure 20-22-3

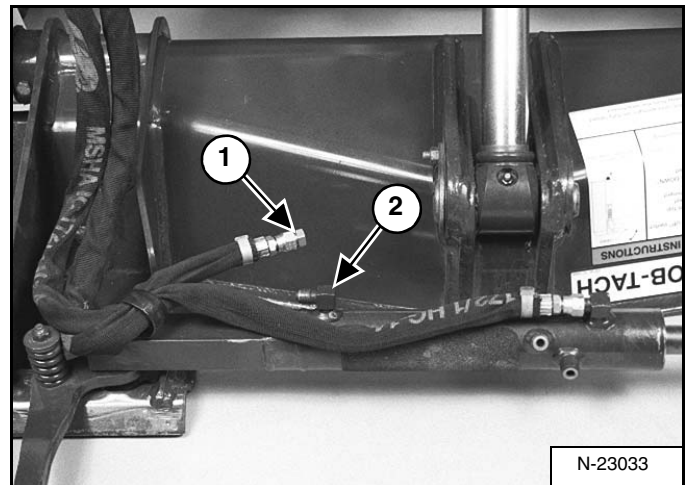

Install a plug in the hose (Item 1) [Figure 20-22-3] and tighten.

Engage the parking brake. Lower the seat bar. Start the engine.

Push and hold the BOB-TACH “WEDGES UP” Switch (Front Accessory Panel).

If there is any leakage from the base end cylinder port (Item 2) [Figure 20-22-3], remove the lift cylinder for repair.

WARNING

AVOID INJURY OR DEATH

Always clean up spilled fuel or oil. Keep heat, flames, sparks or lighted tobacco away from fuel and oil. Failure to use care around combustibles can cause explosion or fire.

W-2103-0508

WARNING

AVOID INJURY OR DEATH

Diesel fuel or hydraulic fluid under pressure can penetrate skin or eyes, causing serious injury or death. Fluid leaks under pressure may not be visible. Use a piece of cardboard or wood to find leaks. Do not use your bare hand. Wear safety goggles. If fluid enters skin or eyes, get immediate medical attention from a physician familiar with this injury.

W-2072-0807

MAIN RELIEF VALVE (CONT'D)

Removal And Installation (Cont'd)

Figure 20-30-6

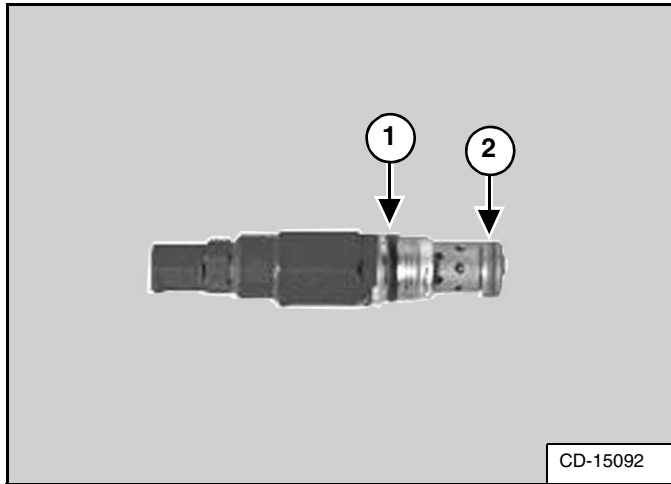

Remove the O-rings and back-up washers from the main relief valve [Figure 20-30-6].

Clean the main relief valve in clean solvent. Use air pressure to dry the valve.

Install new O-rings (Item 1) [Figure 20-30-6] and back-up washers (Item 2) [Figure 20-30-6]. Install the main relief valve and tighten [Figure 20-30-6]. Check the pressure again. (See Checking The Main Relief Valve At Front Auxiliary Hydraulics on Page 20-30-1.)

Adjustment

Figure 20-30-7

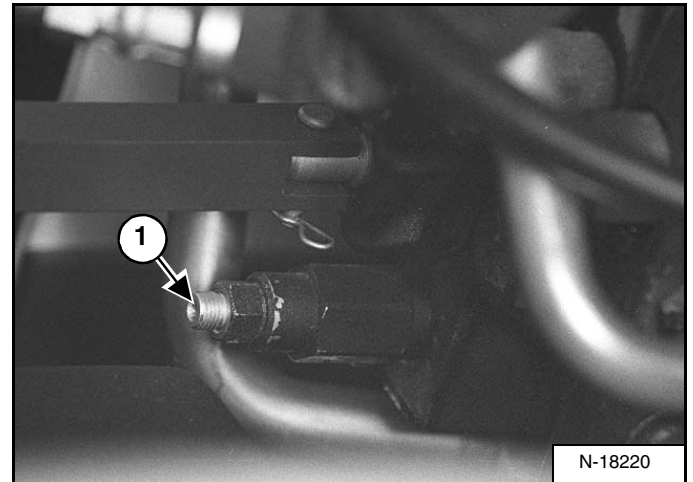

If the pressure is not correct, adjust the main relief valve. Remove the end cap (Item 2) [Figure 20-30-5].

Turn the adjusting screw (Item 1) [Figure 20-30-7] in or out until the pressure is correct. Turning screw in will increase pressure.

NOTE: If the correct pressure can not be reached, replace the main relief valve. Check the pressure setting of the new relief valve.

HYDRAULIC CONTROL VALVE (FOOT CONTROL) (CONT'D)

Removal And Installation (S/N 518915182 & Above) (Cont'd)

Figure 20-40-27

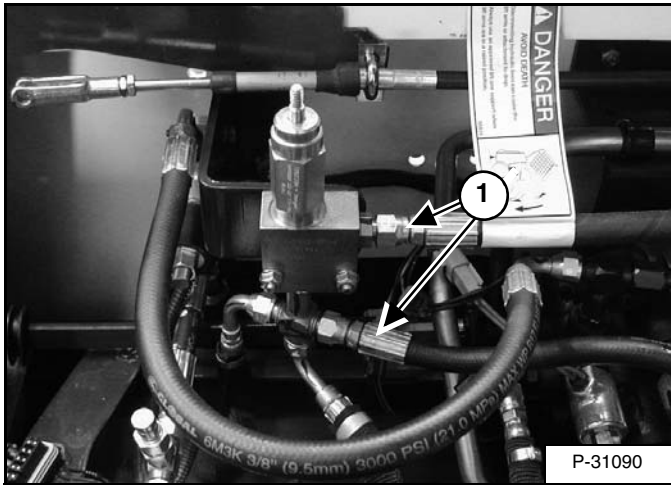

Remove the two hoses (Item 1) [Figure 20-40-27] from the lift arm bypass valve.

Cap and plug the hoses and fittings.

Figure 20-40-28

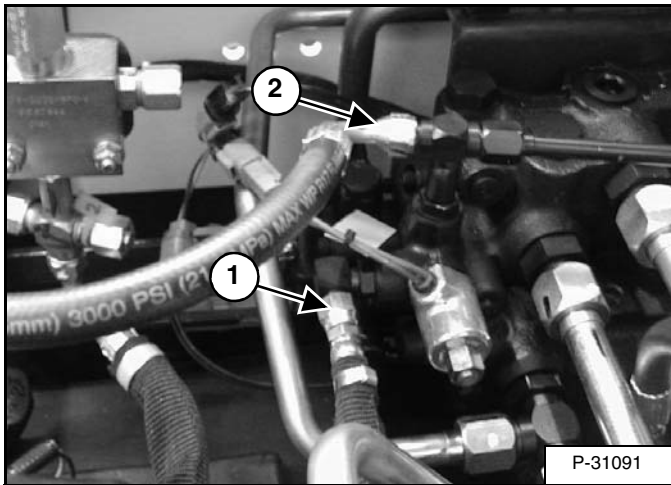

Remove the case drain hose (Item 1) [Figure 20-40-28] and brake valve hose (Item 2) [Figure 20-40-28].

Cap and plug the hoses and fittings.

Figure 20-40-29

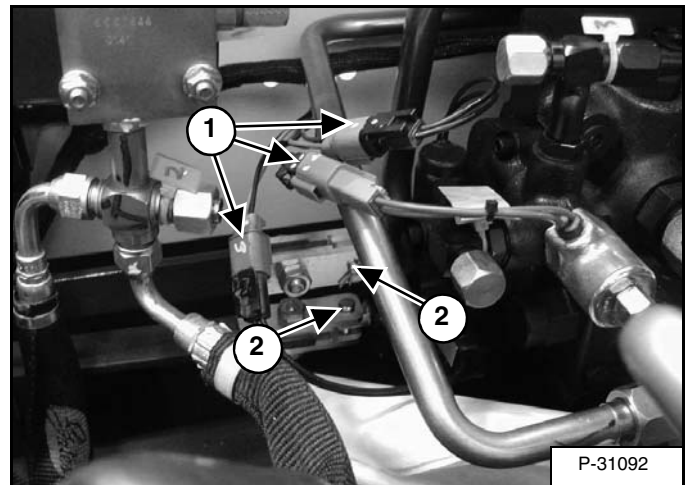

Mark the three wire connectors (Item 1) [Figure 20-40-29] for proper installation.

Disconnect the three wire harness connectors.

Remove the lift and tilt linkage clevis pins (Item 2) [Figure 20-40-29].

Figure 20-40-30

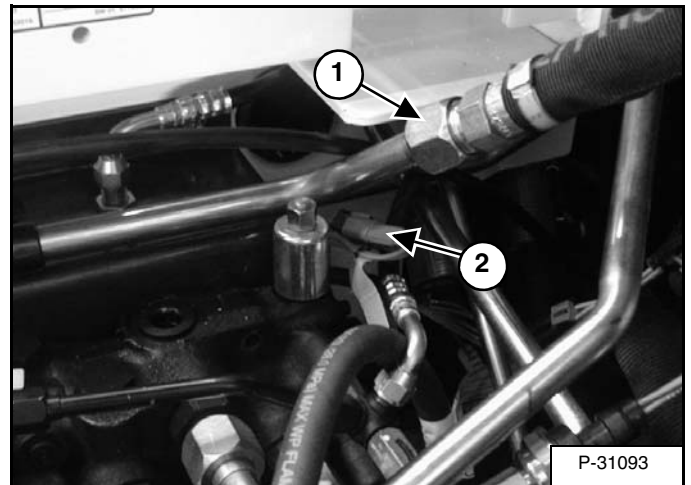

Disconnect the hose (Item 1) [Figure 20-40-30] that goes from the hydraulic pump to the hydraulic control valve.

Disconnect the wire harness (Item 2) [Figure 20-40-30].

HYDRAULIC CONTROL VALVE (FOOT CONTROL) (CONT'D)

BICS™ Valve, Solenoid Disassembly And Assembly (Cont'd)

Figure 20-40-63

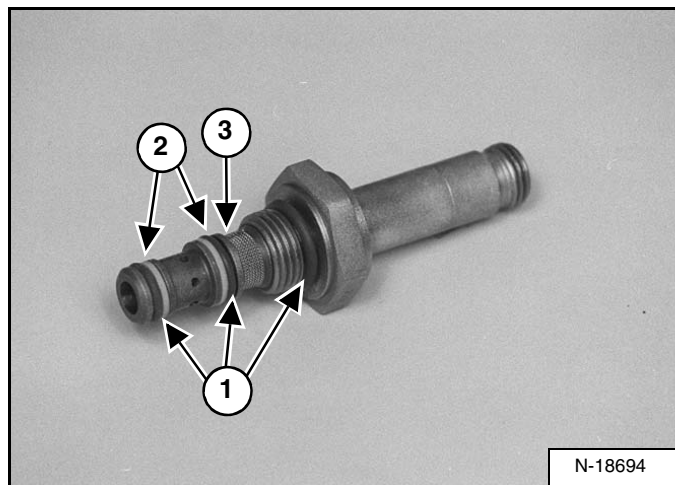

Remove the O-rings (Item 1) [Figure 20-40-63] and back-up washers (Item 2) [Figure 20-40-63] on the stem.

Clean all parts in solvent and dry with compressed air.

Inspect all parts for wear and replace any part showing excessive wear.

NOTE: The screen (Item 3) [Figure 20-40-63] may be cleaned with solvent. If it is torn or worn replace the solenoid stem.

Use only new O-rings and apply oil to all O-rings and back-up washers before installation.

Install new O-rings and new back-up washers on the solenoid stem.

BICS™ Valve, Solenoid Testing

Figure 20-40-64



Use a test meter to measure coil resistance [Figure 20-40-64]. Coil wires do not have polarity. Correct resistance for the auxiliary pressure relief (small) coil is 7-10 ohm and the other coils 5-8 ohms.

Replace the test meter with 12 volt power. You can see and hear the spool shift.

HYDRAULIC CONTROL VALVE (FOOT CONTROL) (CONT'D)

Lift Spool and Detent (Cont'd)

Figure 20-40-96

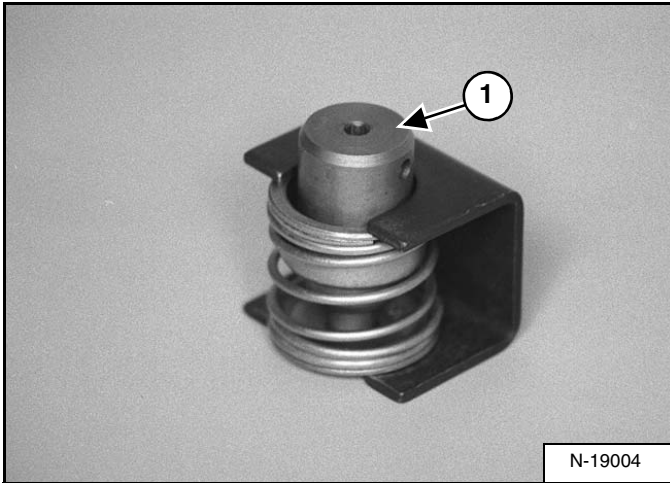

Remove the detent adapter (Item 1) [Figure 20-40-96] from the spring assembly.

Figure 20-40-97

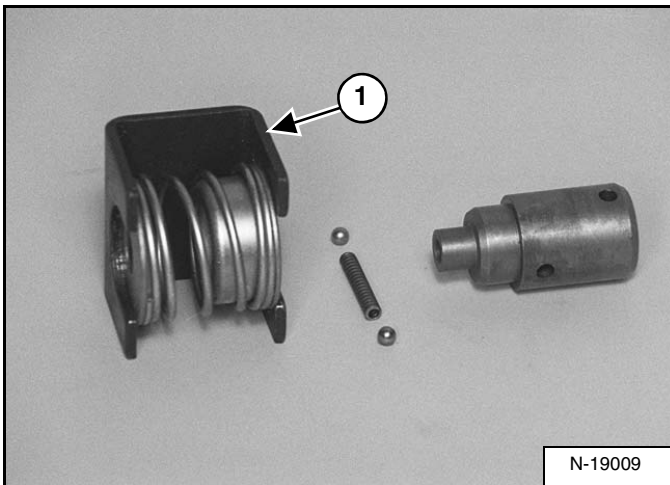

Remove spring tool (Item 1) [Figure 20-40-97] from the spring assembly.

Figure 20-40-98

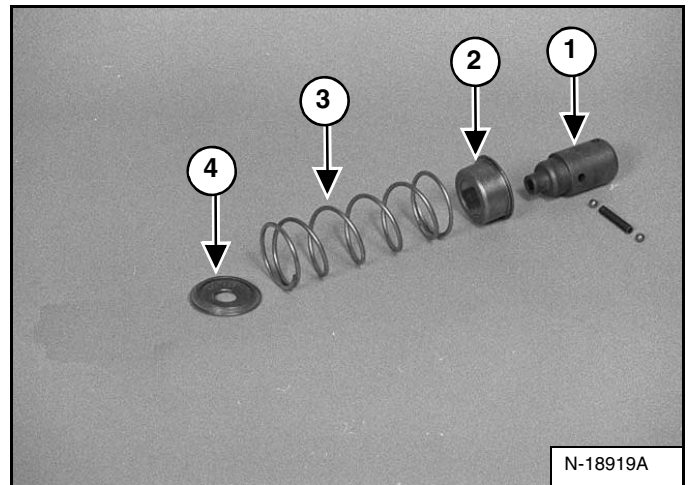

Inspect the adapter (Item 1) [Figure 20-40-98], collar (Item 2) [Figure 20-40-98], spring (Item 3) [Figure 20-40-98], and washer (Item 4) [Figure 20-40-98].

Figure 20-40-99

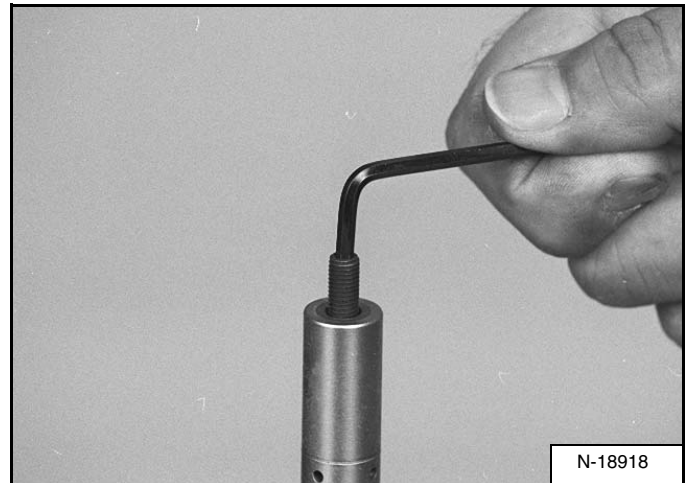

Remove the stud from the end of the spool [Figure 20-40-99].

HYDRAULIC CONTROL VALVE (FOOT CONTROL) (CONT'D)

Auxiliary Electric Solenoid Disassembly

Figure 20-40-136

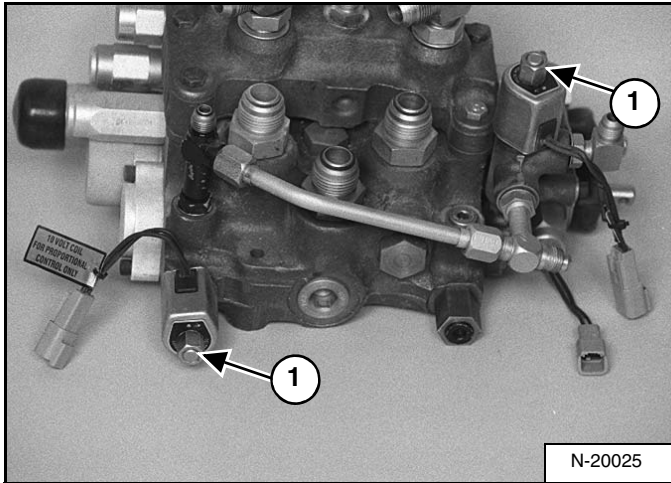

Remove the nut (Item 1) [Figure 20-40-136] from both solenoids.

Installation: Tighten the nut to 8 - 12 ft.-lb. (11 - 16 N•m) torque.

Figure 20-40-137

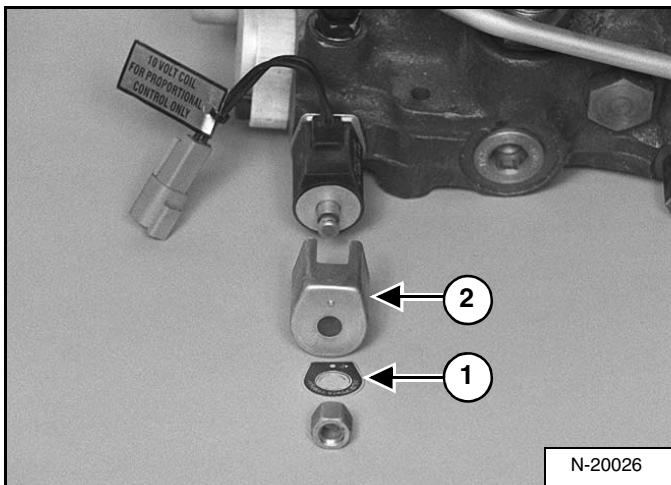

Remove the end plate (Item 1) [Figure 20-40-137] and housing (Item 2) [Figure 20-40-137].

Figure 20-40-138

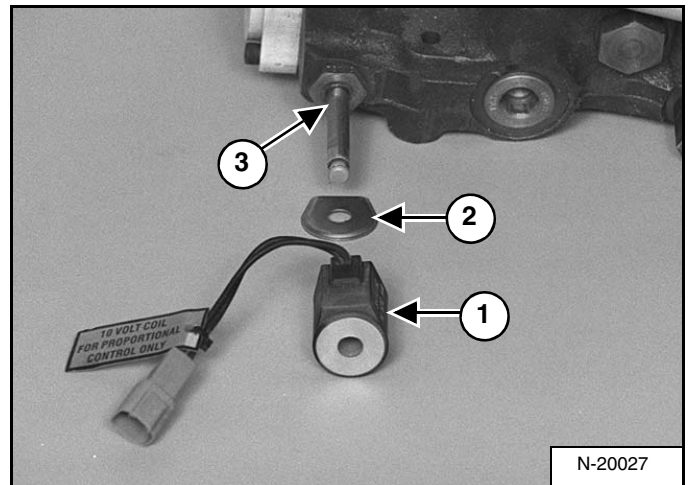

Remove the coil (Item 1) [Figure 20-40-138] and end plate (Item 2) [Figure 20-40-138].

Remove the solenoid stem (Item 3) [Figure 20-40-138].

Installation: Tighten valve to 8 - 12 ft.-lb. (11 - 16 N•m) torque.

Figure 20-40-139

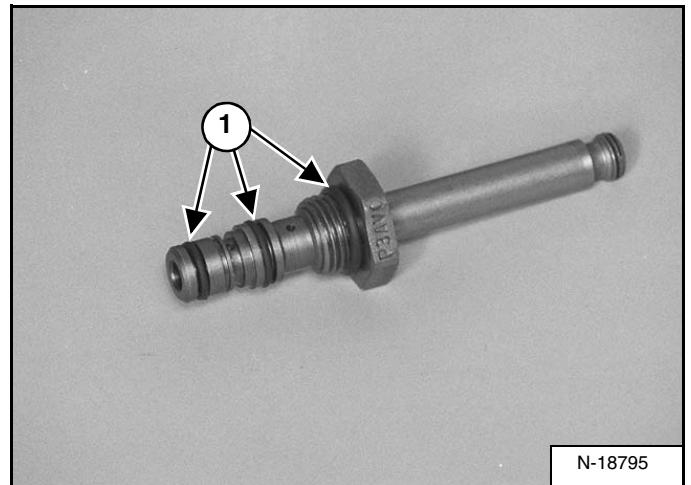

Remove the O-rings (Item 1) [Figure 20-40-139] from the solenoid stem.

HYDRAULIC CONTROL VALVE (ADVANCED CONTROL SYSTEM) (ACS) (CONT'D)

Removal And Installation (S/N 518915181 & Below) (Cont'd)

Figure 20-41-30

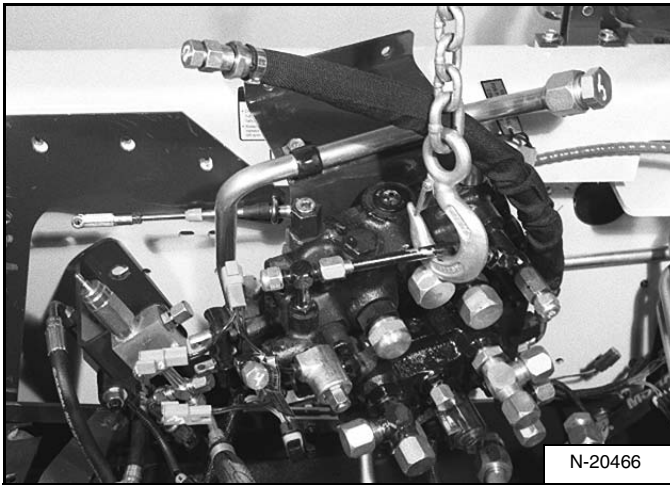

Move the control valve towards the front of the loader and remove the valve from the loader [Figure 20-41-30].

Figure 20-41-31

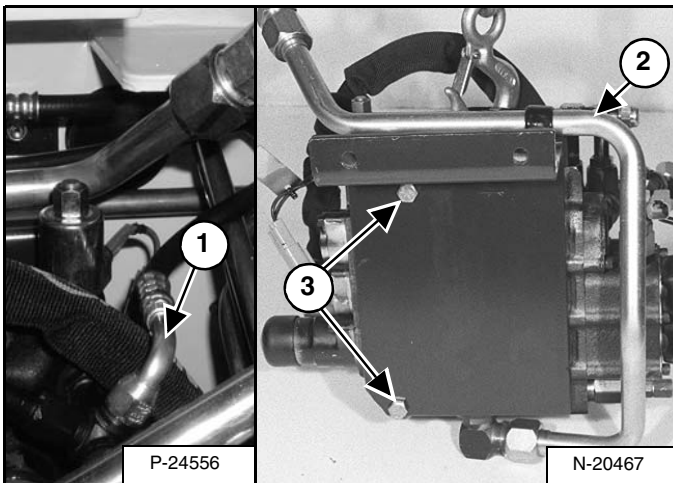

Remove the accumulator hose (Item 1) [Figure 20-41-31].

Remove the tubeline (Item 2) [Figure 20-41-31] from the valve. Remove the two bolts (Item 3) [Figure 20-41-31] and remove the mount.

Actuator Removal And Installation (In Loader) (S/N 518915182 & Above)

Raise the lift arms and install an approved lift arm support device. (See LIFT ARM SUPPORT DEVICE on Page 10-20-1.)

WARNING

Never work on a machine with the lift arms up unless the lift arms are secured by an approved lift arm support device. Failure to use an approved lift arm support device can allow the lift arms or attachment to fall and cause injury or death.

W-2059-0598

Stop the engine. Raise the seat bar.

Figure 20-41-32

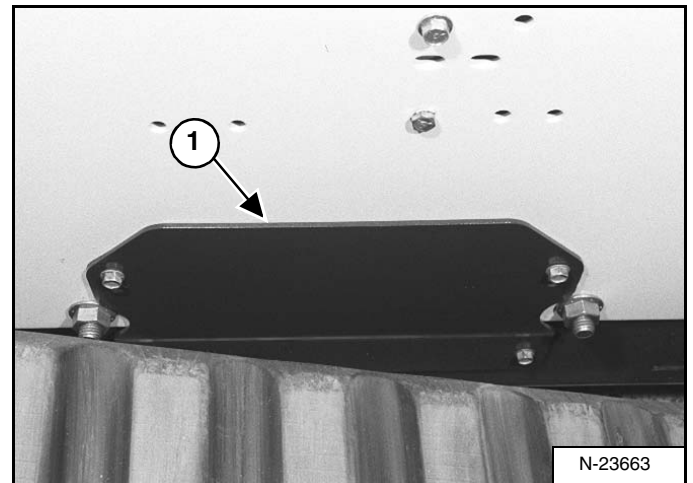

Remove the access cover (Item 1) [Figure 20-41-32] from the right side of the loader frame.

Unplug the actuator connectors from the harness.

HYDRAULIC CONTROL VALVE (ADVANCED CONTROL SYSTEM) (ACS) (CONT'D)

BICS™ Valve, Removal And Installation (Cont'd)

Figure 20-41-64

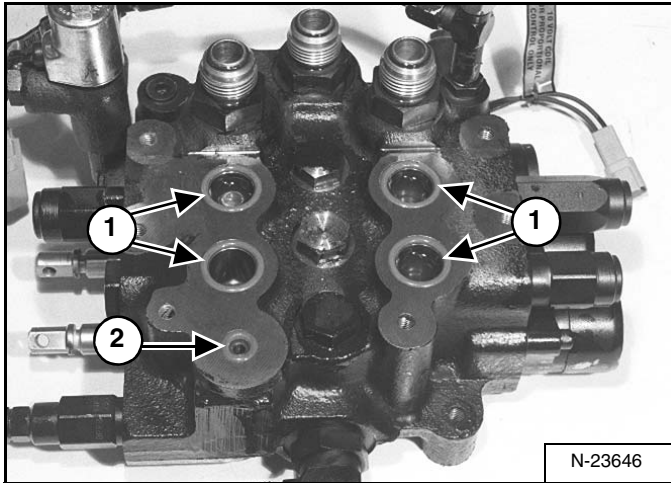

Remove the four large O-rings (Item 1) [Figure 20-41-64] and the small O-ring (Item 2) [Figure 20-41-64] from the top of the control valve.

Install the four large O-rings (Item 1) [Figure 20-41-64] and the small O-ring (Item 2) [Figure 20-41-64] on the top of the control valve.

Figure 20-41-65

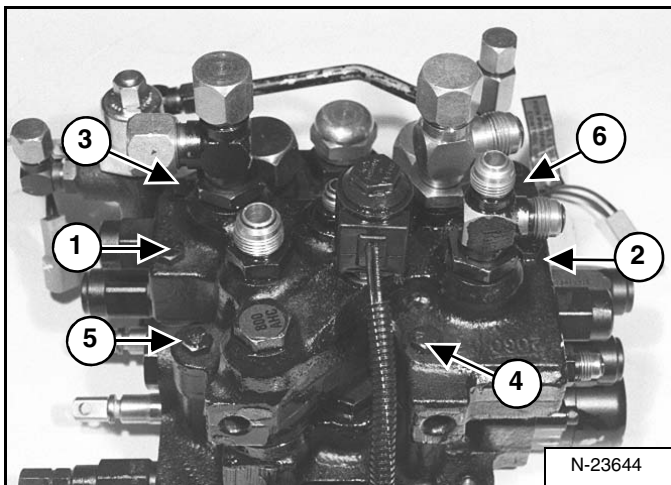

Install the six mounting bolts [Figure 20-41-65].

The chart below lists the correct torque specifications and tightening sequence when reinstalling the BICS™ valve assembly to the control valve. Thoroughly clean and dry bolts and threads in valve. Use liquid adhesive Loctite® #242 or equivalent.

| Step | Torque | Sequence |
|------|--|-------------------|
| 1 | 110 - 130 in.-lb. (12,4 - 14,7 N•m) | 1, 2, 3, 4, 5 & 6 |
| 2 | 190 - 210 in.-lb. (21,5 - 23,7 N•m) | |
| 3* | 190 - 210 in. lb. (21,5 - 23,7 N•m) | |

*Torque must be 190 - 210 in.-lb. (21,5 - 23,7 N•m) for every bolt or repeat step 3.

BICS™ Valve, Lift Arm Bypass Orifice Disassembly And Assembly

Figure 20-41-66

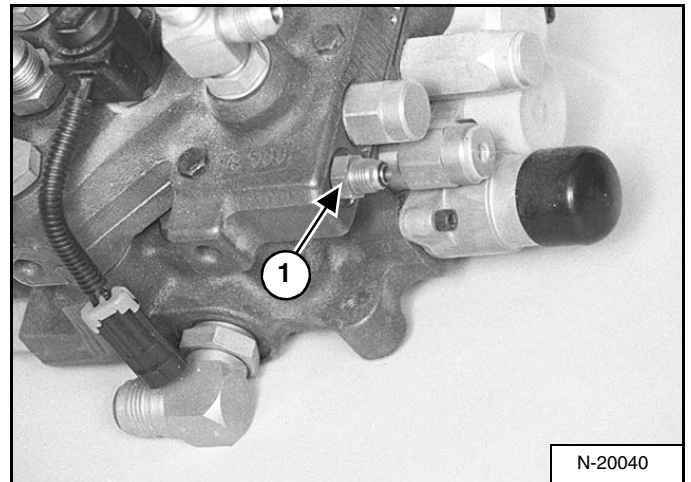

Remove the fitting (Item 1) [Figure 20-41-66] from the valve.

HYDRAULIC CONTROL VALVE (ADVANCED CONTROL SYSTEM) (ACS) (CONT'D)

Port Relief Valve (Cont'd)

Figure 20-41-92

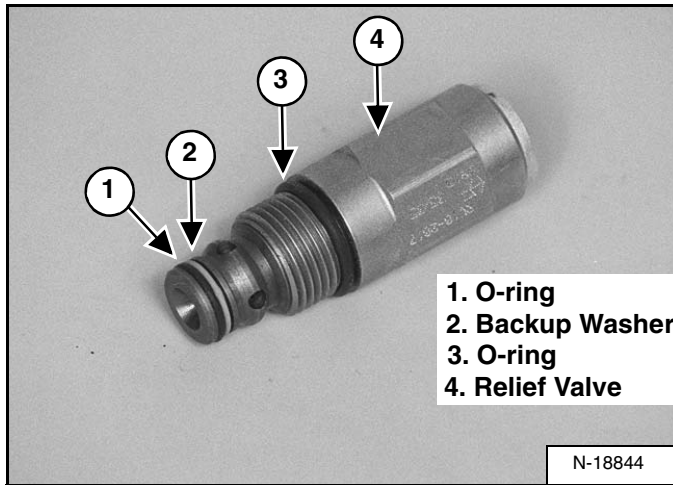

Remove the O-rings and back-up washer from the port relief valve [Figure 20-41-92].

Anti-Cavitation Valve / Port Relief Valve

Figure 20-41-93

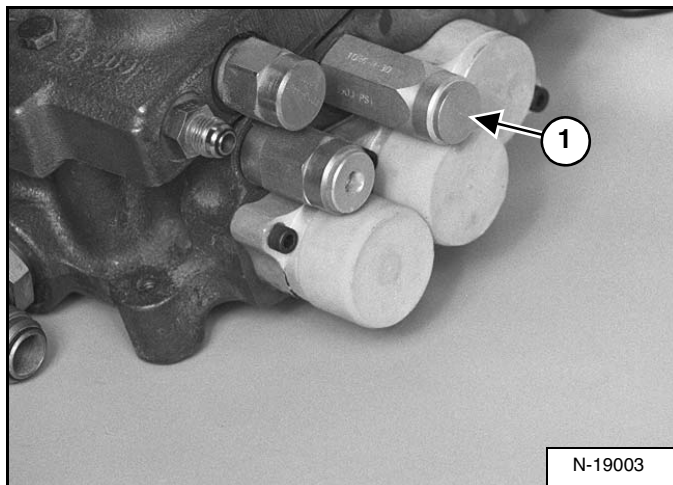

Loosen the anti-cavitation valve (Item 1) [Figure 20-41-93].

Installation: Always use new O-rings and back-up washers. Tighten to 35 - 40 ft.-lb. (47 - 54 N•m) torque.

Figure 20-41-94

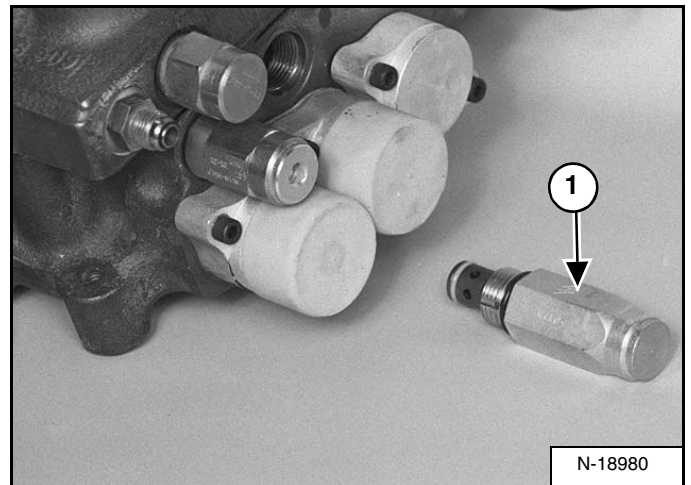

Remove the anti-cavitation / port relief valve (Item 1) [Figure 20-41-94] from the control valve for the tilt section.

Figure 20-41-95

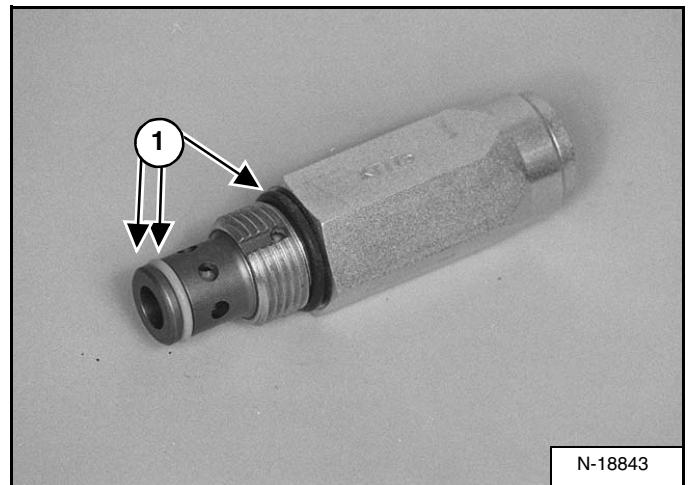

Remove the O-rings (Item 1) [Figure 20-41-95] from the anti-cavitation / port relief valve.

WARNING

AVOID INJURY OR DEATH

Always clean up spilled fuel or oil. Keep heat, flames, sparks or lighted tobacco away from fuel and oil. Failure to use care around combustibles can cause explosion or fire.

W-2103-0508

Disassembly And Assembly

Figure 20-50-5

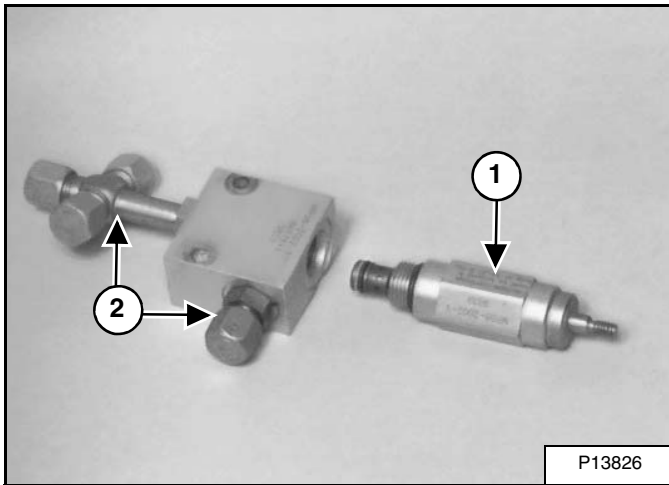

Remove the bypass valve (Item 1) [Figure 20-50-5] from the valve block. Inspect the bypass valve for damage and replace if necessary.

Installation: Tighten the valve to 33 - 37 ft.-lb. (45 - 50 N•m) torque.

Inspect the hydraulic fittings (Item 2) [Figure 20-50-5] on the valve block for damage and replace if necessary.

HYDRAULIC PUMP (ALUMINUM) (CONT'D)

Assembly (518916260 & Below) (Cont'd)

Figure 20-60-21

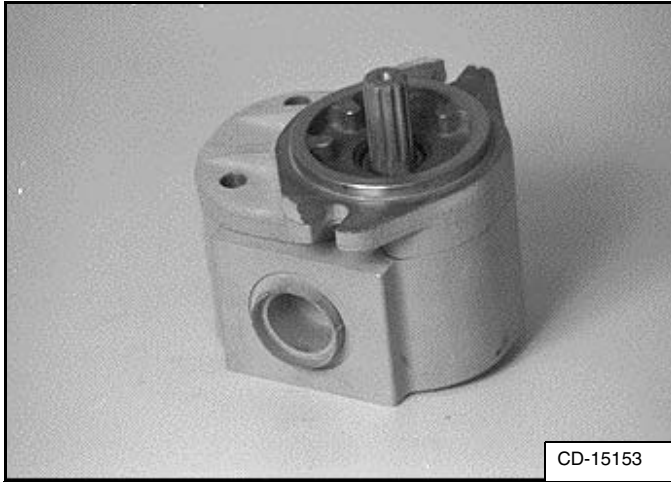

Install the mounting flange housing on the pump housing [Figure 20-60-21].

Figure 20-60-22

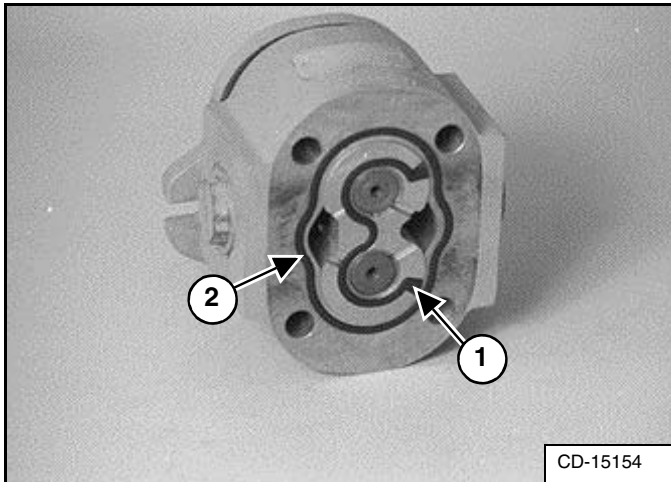

Install the back-up seals / O-ring seals (Item 1) [Figure 20-60-22].

Install the large O-ring (Item 2) [Figure 20-60-22].

Figure 20-60-23

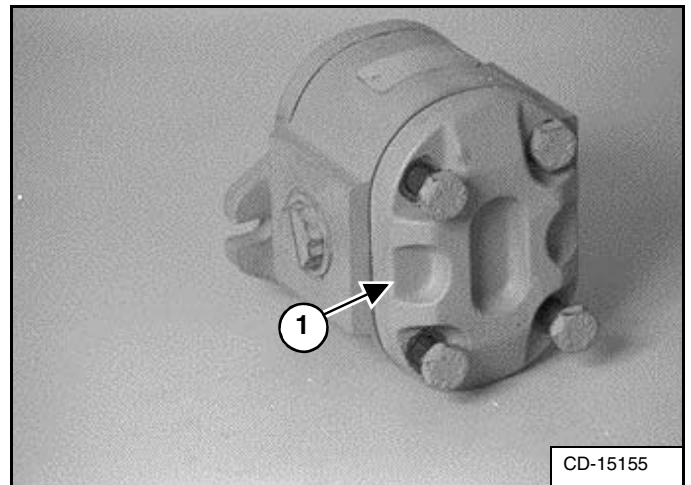

Install the end housing (Item 1) [Figure 20-60-23].

Install the four pump housing bolts [Figure 20-60-23].

Figure 20-60-24

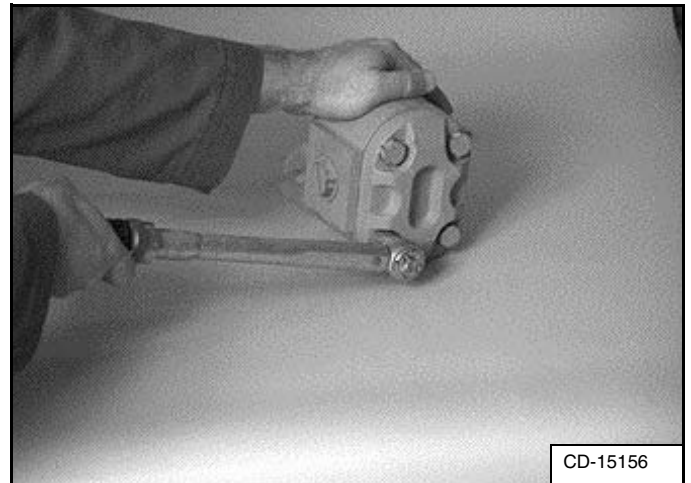

Tighten the bolts to 45 - 50 ft.-lb. (61 - 68 N•m) torque [Figure 20-60-24].

HYDRAULIC PUMP (ALUMINUM HI-FLOW) (CONT'D)

Disassembly (518916427 & Below) (Cont'd)

Figure 20-61-21

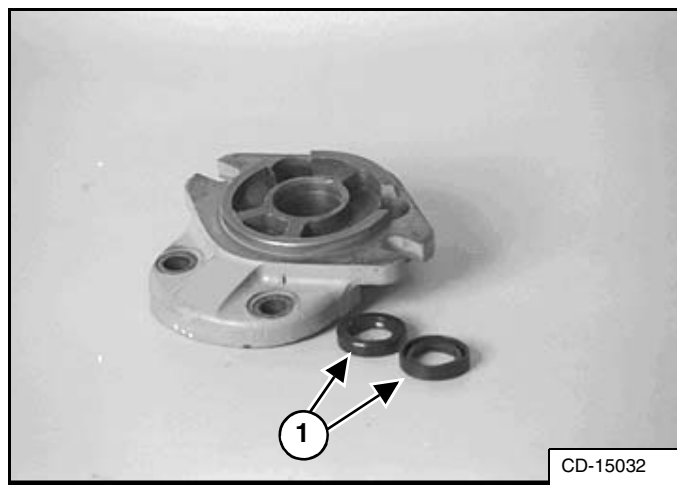

Remove the two seals (Item 1) [Figure 20-61-21] from the mounting flange housing.

Figure 20-61-22

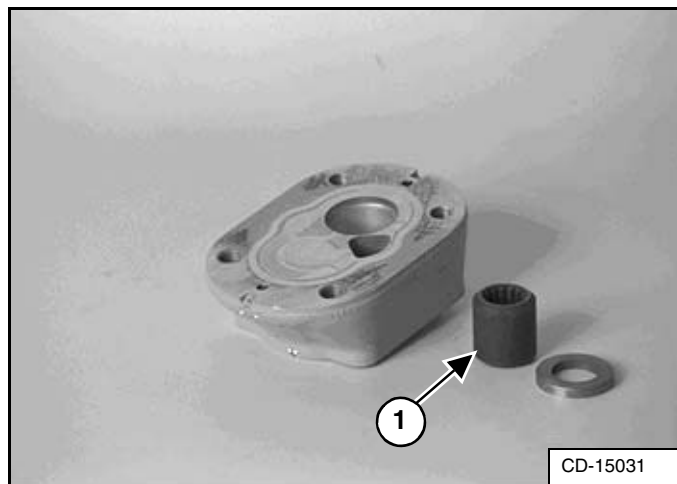

Check the connecting coupler (Item 1) [Figure 20-61-22] in the center housing. If worn or damaged, use a press and correct size driver tool to remove it from the center housing.

HYDRAULIC PUMP (CAST IRON)

Disassembly And Assembly (518916261 & Above)

IMPORTANT

When repairing hydrostatic and hydraulic systems, clean the work area before disassembly and keep all parts clean. Always use caps and plugs on hoses, tubelines and ports to keep dirt out. Dirt can quickly damage the system.

I-2003-0888

Figure 20-62-7

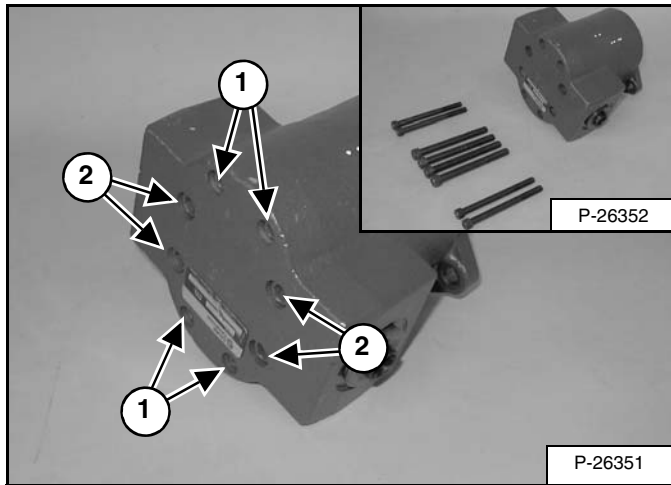

Mark the pump sections for correct assembly [Figure 20-62-7].

Remove the four smaller pump housing bolts (Item 1) [Figure 20-62-7].

Remove the four larger pump housing bolts (Item 2) [Figure 20-62-7].

Installation: Tighten the four smaller bolts (Item 1) [Figure 20-62-7] to 30 ft.-lb. (40,7 N•m) torque. Tighten the four larger bolts (Item 2) [Figure 20-62-7] to 54 ft.-lb. (73,2 N•m) torque.

Figure 20-62-8

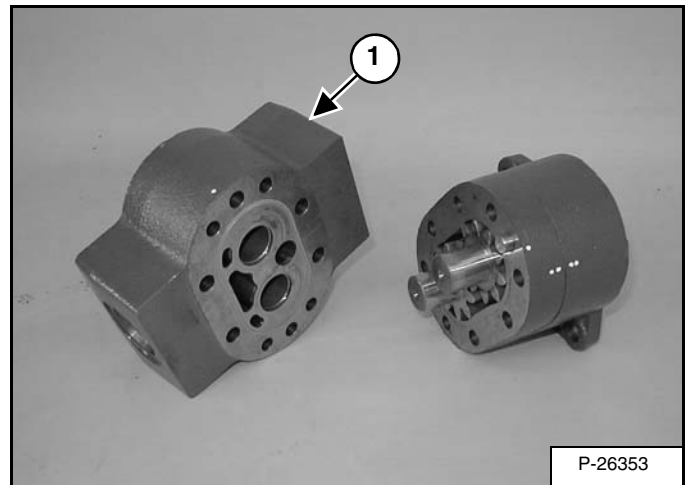

Remove the pump end section (Item 1) [Figure 20-62-8].

Figure 20-62-9

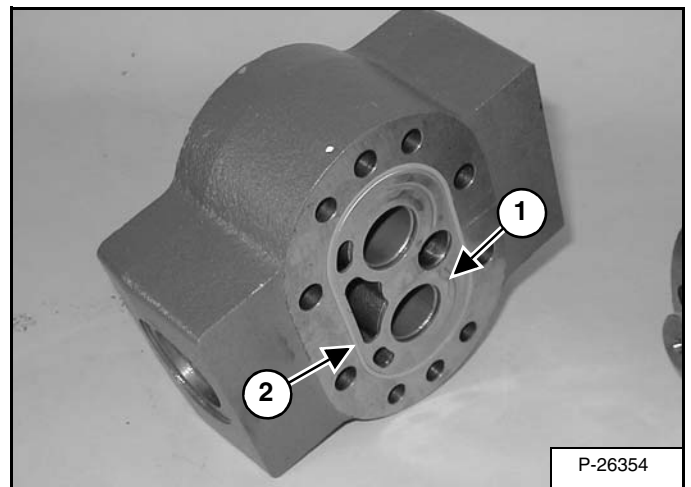

Remove the wear plate (Item 1) [Figure 20-62-9] & [Figure 20-62-10] and section seal (Item 2) [Figure 20-62-9] & [Figure 20-62-10] from the pump end section.

HYDRAULIC PUMP (CAST IRON HI-FLOW) (CONT'D)

Inline Hydraulic Pump Test (518916428 & Above) (HI-FLOW) (Cont'd)

IMPORTANT

The hydraulic tester must be in the fully open position before you start the engine.

I-2024-0284

Figure 20-63-8

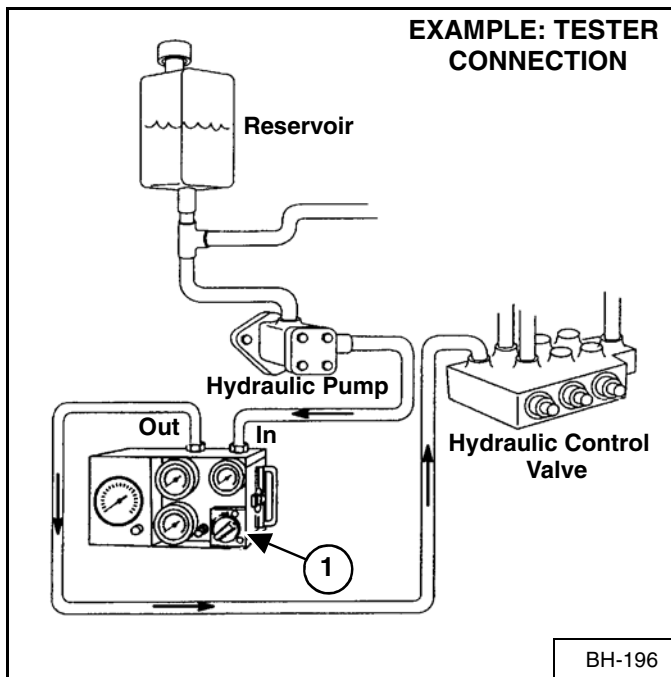

Sample tester connection shown [Figure 20-63-8].

This procedure will require a operator in the cab and one operator running the tester.

Start the engine and run at low idle RPM. Press the Front Auxiliary button. Press the High Flow button. Engage the front auxiliary with the trigger on the right handle. Make sure the tester is connected correctly. If no flow is indicated on the tester, the hoses are connected wrong. With the hoses connected correctly, increase the engine speed to full RPM*.

Warm the fluid to 140° F (60° C) by turning the restrictor control (Item 1) [Figure 20-63-8] on the tester to about 1000 PSI (6895 kPa).

NOTE: DO NOT EXCEED 3300 PSI.

Turn the restrictor control on the tester clockwise to 3000 PSI and the flow should go to zero GPM. If the pressure readings are not obtained go to the High Flow Relief Pump Adjustment (See High Flow Relief Adjustment Procedure (518916428 & Above) on Page 20-63-6.). If the pressure readings are correct, continue on to the next paragraph.

Open the restrictor control and record the free flow (GPM) at full RPM.

Record the flow (GPM) at 2500 PSI, this is the high pressure flow. The high pressure flow must be at least 80% of free flow.

$$\% = \frac{\text{HIGH PRESSURE FLOW (GPM)}}{\text{FREE FLOW (GPM)}} \times 100$$

A low percentage may indicate a failed pump.

*See Hydraulic System on Page SPEC-10-3 for system relief pressure and full RPM.

HYDRAULIC PUMP (CAST IRON HI-FLOW) (CONT'D)

Disassembly And Assembly (518916428 & Above) (Cont'd)

Figure 20-63-31

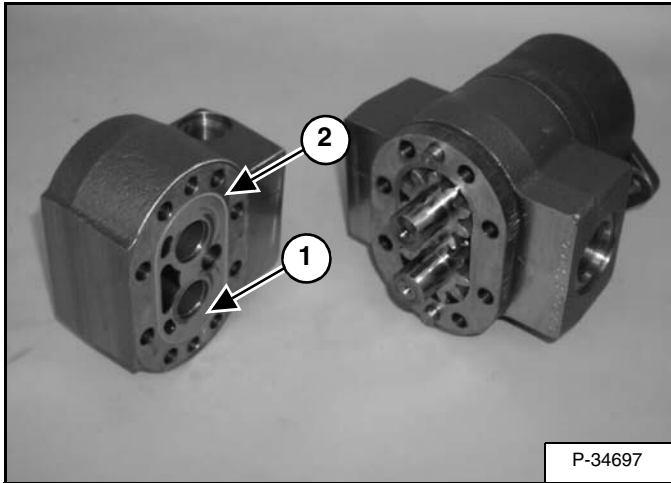

Remove the wear plate (Item 1) and section seal (Item 2) [Figure 20-63-31] from the pump end section.

Figure 20-63-32

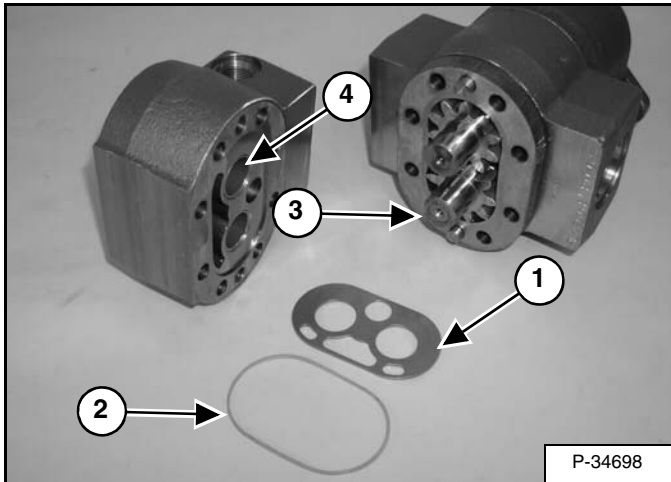

NOTE: Position wear plate (Item 1) [Figure 20-63-32] inlets and traps as shown with bronze side toward gears.

NOTE: Inspect the pump end section (Item 3) and bushings (Item 4) [Figure 20-63-32]. If excessive wear or damage is visible, the pump must be replaced.

Figure 20-63-33

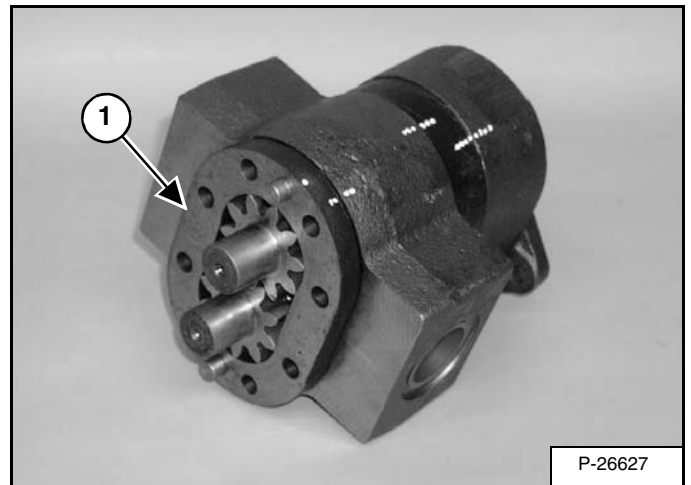

Remove the pump center section (Item 1) [Figure 20-63-33] & [Figure 20-63-34] from the pump center section.

Figure 20-63-34

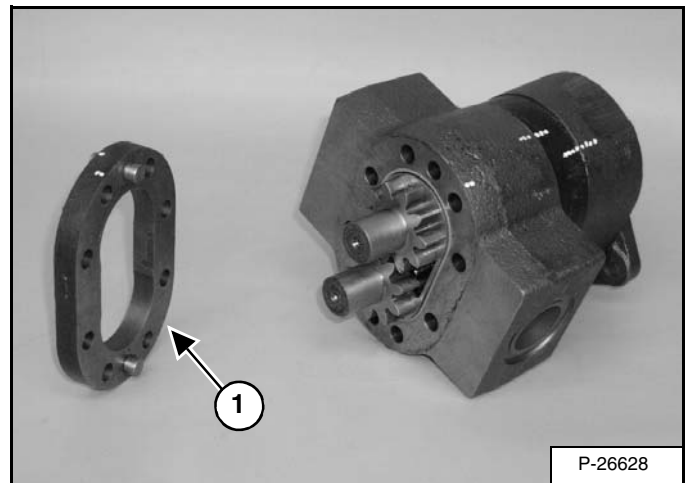

NOTE: Inspect the pump center section (Item 1) [Figure 20-63-34]. If excessive wear or damage is visible, the pump must be replaced.

HYDRAULIC / HYDROSTATIC FILTER (CONT'D)

Housing Removal And Installation (S/N 518913533 & Above)

! DANGER

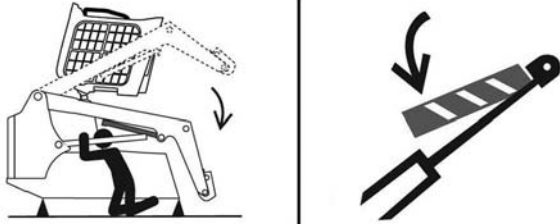

P-90328

AVOID DEATH

- Disconnecting or loosening any hydraulic tubeline, hose, fitting, component or a part failure can cause lift arms to drop.
- Keep out of this area when lift arms are raised unless supported by an approved lift arm support. Replace if damaged.

D-1009-0409

! WARNING

Never work on a machine with the lift arms up unless the lift arms are secured by an approved lift arm support device. Failure to use an approved lift arm support device can allow the lift arms or attachment to fall and cause injury or death.

W-2059-0598

Figure 20-70-5

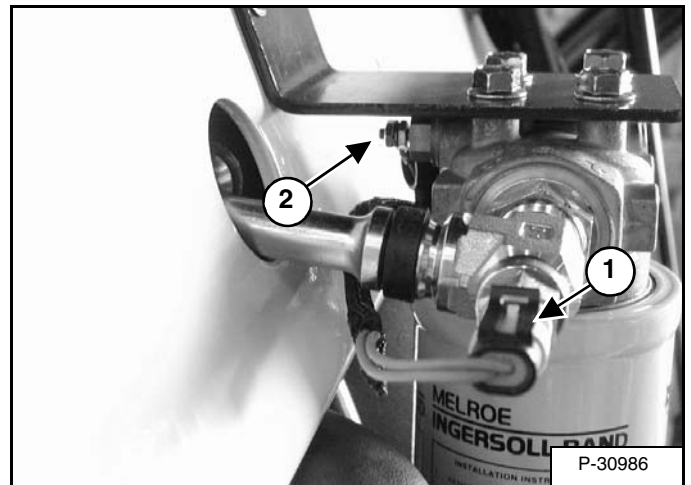

Raise the lift arms and install an approved lift arm support device. (See LIFT ARM SUPPORT DEVICE on Page 10-20-1.)

Raise the operator cab. (See Raising The Operator Cab on Page 10-30-1.)

Disconnect the electrical connector (Item 1) [Figure 20-70-5] from the filter sender.

Loosen the nut (Item 2) [Figure 20-70-5] and remove the electrical wire from the filter block.

Figure 20-70-6



Remove the hose clamp (Item 1) [Figure 20-70-6], and remove the hydraulic hose, breather hose and wiring harness from the filter housing.

SELECT VALVE

Checking The High Flow Pump Relief Valve (518916427 & Below)

Figure 20-100-1

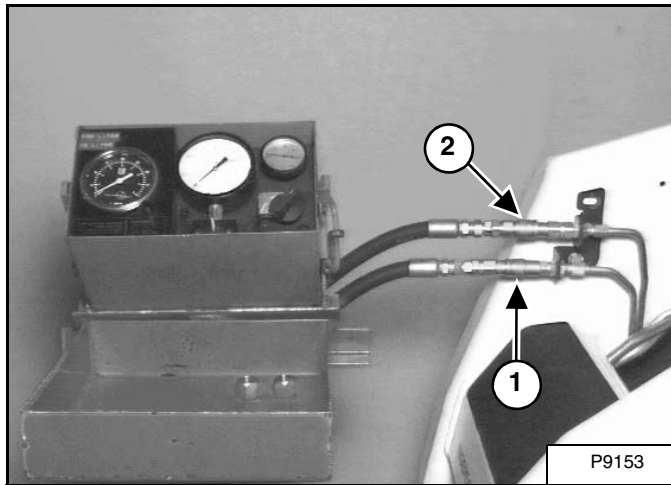

The tools listed will be needed to do the following procedure:

MEL10003 - Hydraulic Tester
MEL10006 - Hydraulic Test Kit

Lift and block the loader. (See **LIFTING AND BLOCKING THE LOADER** on Page 10-10-1.)

Connect the IN port of the hydraulic tester to the female quick couplers (Item 1) [Figure 20-100-1] on the loader.

Connect the OUT port of the hydraulic tester to the male quick coupler (Item 2) [Figure 20-100-1] on the loader.

IMPORTANT

The hydraulic tester must be in the fully open position before you start the engine.

I-2024-0284

WARNING

Put jackstands under the front axles and rear corners of the frame before running the engine for service. Failure to use jackstands can allow the machine to fall or move and cause injury or death.

W-2017-0286

Figure 20-100-2

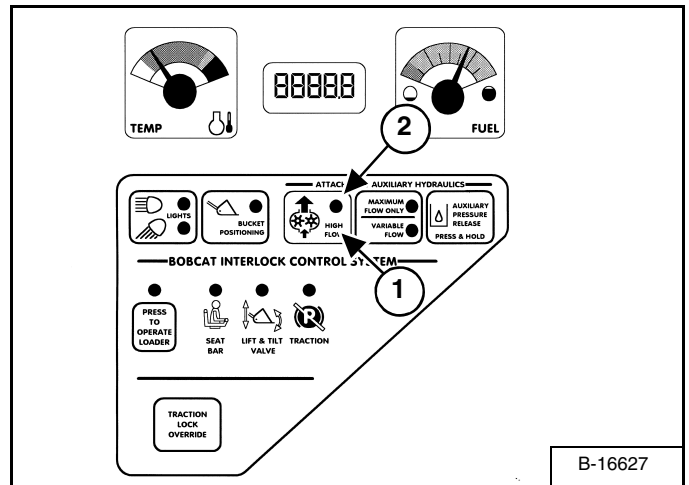

Start the engine and run at low idle RPM. Push the mode switch (Item 1) [Figure 20-100-2] once (on the instrument panel) to engage the front auxiliary hydraulics momentarily, the light (Item 2) [Figure 20-100-2] will come ON.

Push the rocker switch on the left steering handle for fluid pressure to the secondary quick couplers.

Watch the flow meter on the hydraulic tester to make sure the flow is correct. Increase the engine speed to full RPM.

The free flow should be approximately 10.0 GPM (37,85 L/min.). Turn the restrictor control, on the tester, until the main relief valve opens. The correct pressure for the main relief is approximately 3000 PSI (20685 kPa).

Release the rocker switch on the left steering handle to disengage the flow to the secondary quick couplers.

Figure 20-100-3

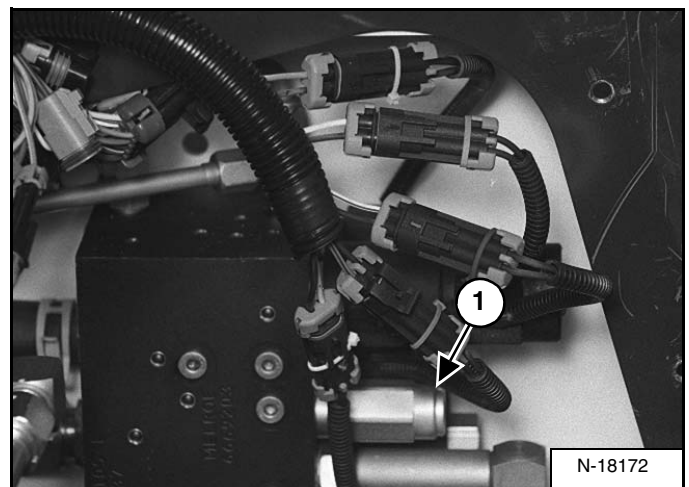

If the relief pressure is not correct, stop the engine. Remove and inspect the relief valve (Item 1) [Figure 20-100-3].

REAR AUXILIARY DIVERTER VALVE

Disassembly

Clean the diverter block to remove dirt before disassembly. Block ports are labeled for correct assembly.

IMPORTANT

When repairing hydrostatic and hydraulic systems, clean the work area before disassembly and keep all parts clean. Always use caps and plugs on hoses, tubelines and ports to keep dirt out. Dirt can quickly damage the system.

I-2003-0888

Figure 20-110-1

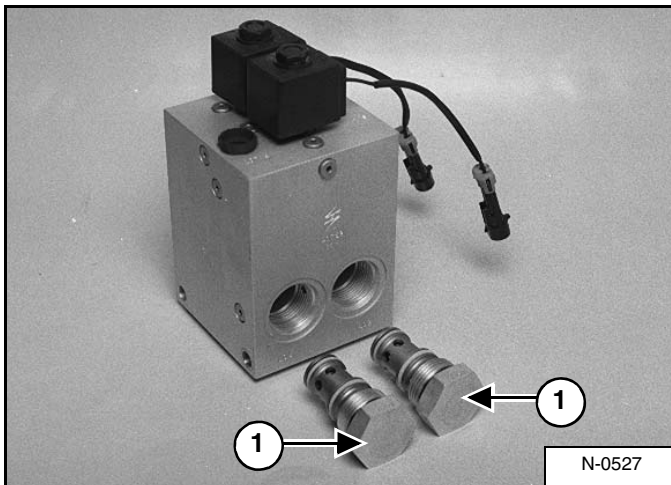

Remove the logic cartridge valves from block ports LC1 and LC2 (Item 1) [Figure 20-110-1].

Figure 20-110-2

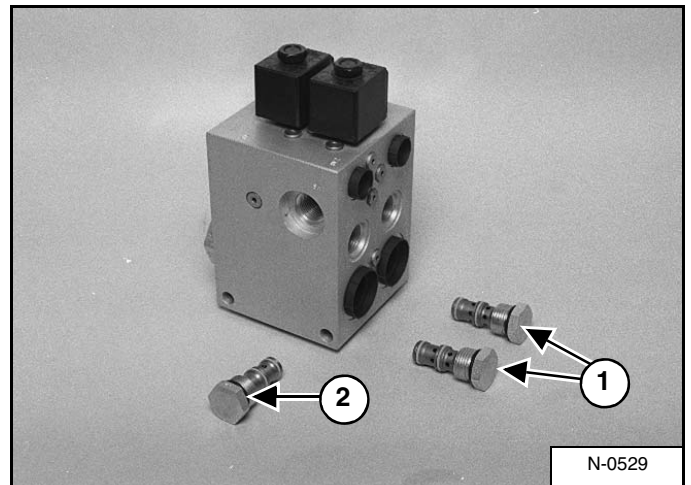

Remove the pilot check valves from block ports PC1 and PC2 (Item 1) [Figure 20-110-2].

Remove the shuttle check valve from block port SH1 (Item 2) [Figure 20-110-2].

Figure 20-110-3

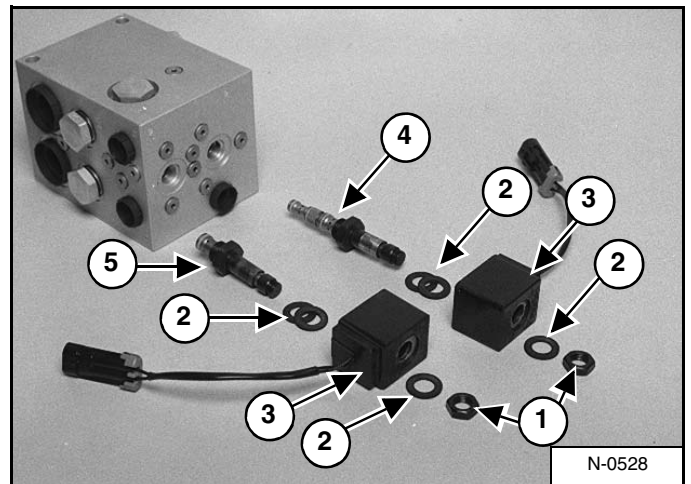

Remove the nuts (Item 1) [Figure 20-110-3], seal washers (Item 2) [Figure 20-110-3], and solenoid valve coils (Item 3) [Figure 20-110-3].

Remove the diverter control solenoid valve (Item 4) [Figure 20-110-3] from port SV1. Remove the pressure relieving solenoid valve (Item 5) [Figure 20-110-3] from block port SV2.

Inspection

Inspect cartridges, check valves, solenoid valves and sealing washers for contamination or damage. Wash all parts in clean solvent. Use air pressure for drying them. Install new O-rings and back-up washers.

Inspect diverter block cavities for contamination. Wash block in clean solvent. Use air pressure to dry.

AUXILIARY PRESSURE RELEASE (ACCUMULATOR)

Removal and Installation (518916010 & Below)

IMPORTANT

When repairing hydrostatic and hydraulic systems, clean the work area before disassembly and keep all parts clean. Always use caps and plugs on hoses, tubelines and ports to keep dirt out. Dirt can quickly damage the system.

I-2003-0888

! DANGER

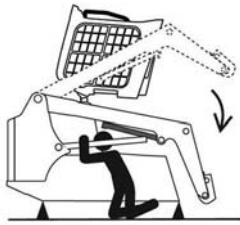

P-90328

AVOID DEATH

- Disconnecting or loosening any hydraulic tubeline, hose, fitting, component or a part failure can cause lift arms to drop.
- Keep out of this area when lift arms are raised unless supported by an approved lift arm support. Replace if damaged.

D-1009-0409

! WARNING

Never work on a machine with the lift arms up unless the lift arms are secured by an approved lift arm support device. Failure to use an approved lift arm support device can allow the lift arms or attachment to fall and cause injury or death.

W-2059-0598

Raise the lift arms and install an approved lift arm support device. (See LIFT ARM SUPPORT DEVICE on Page 10-20-1.)

Stop the engine. Raise the seat bar.

Raise the operator cab. (See Raising The Operator Cab on Page 10-30-1.)

Clean the area around the control valve.

Figure 20-130-1

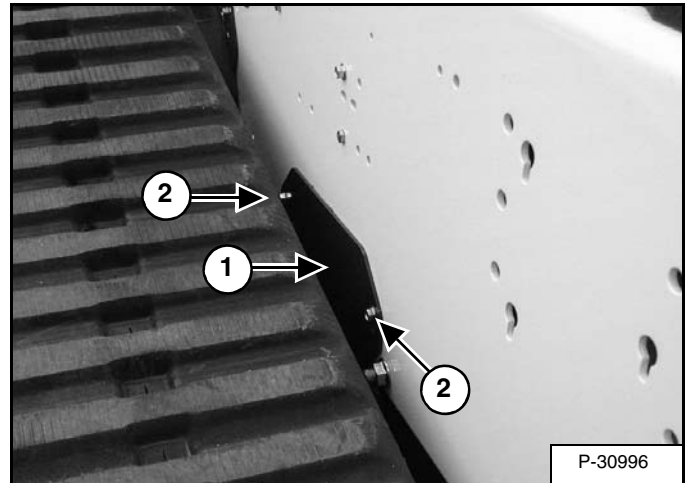

Remove the right side motor cover (Item 1) [Figure 20-130-1], by removing the four bolts (Item 2) [Figure 20-130-1].

Figure 20-130-2

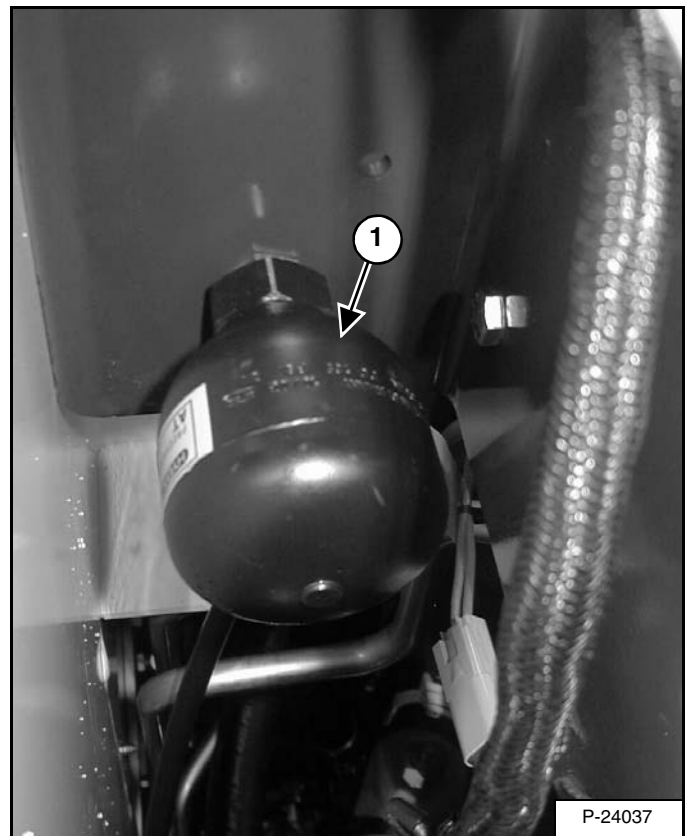

Locate the accumulator (Item 1) [Figure 20-130-2] through the right motor cover opening.

HYDROSTATIC MOTOR (CONT'D)

Parts Identification

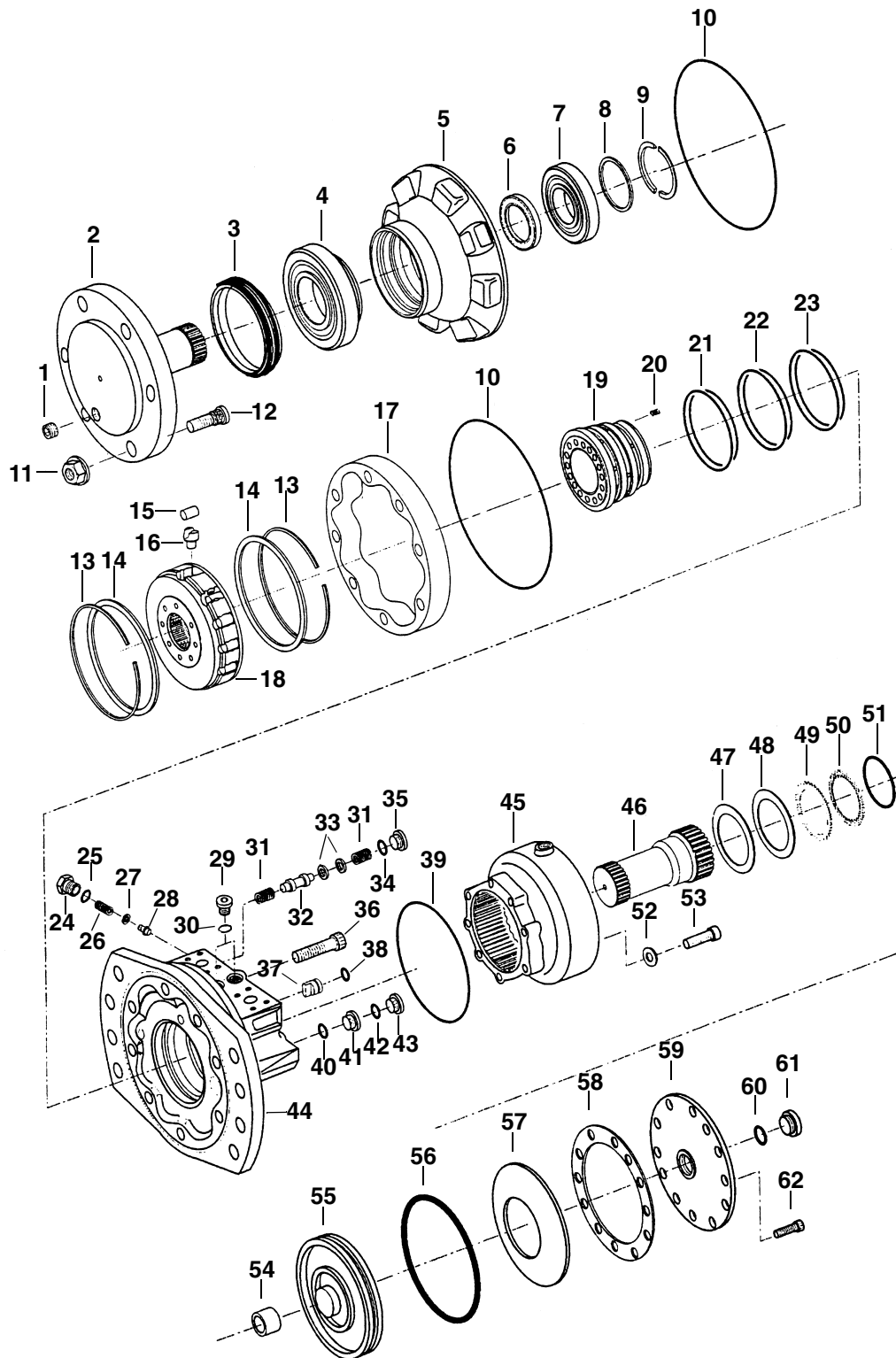

B-16807

HYDROSTATIC MOTOR (CONT'D)

Disassembly (Cont'd)

Figure 30-20-37

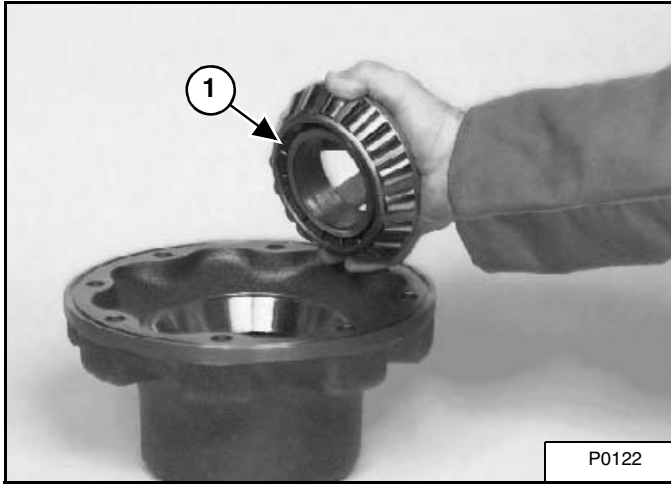

Remove and inspect the bearing (Item 1) [Figure 30-20-37] located in the front housing.

Replace the bearing if worn or damaged.

Figure 30-20-38

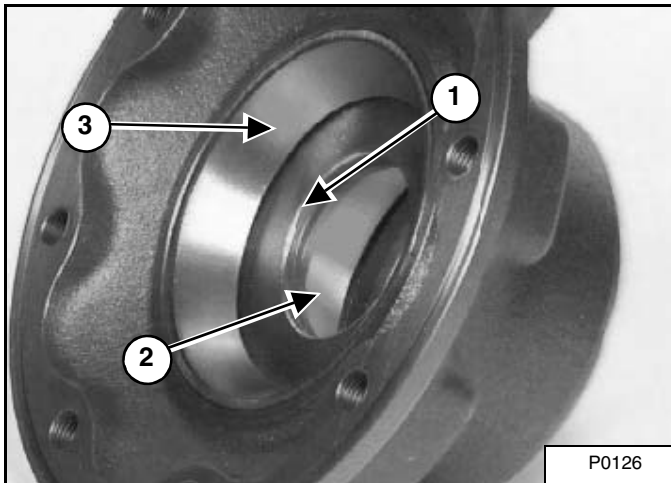

Remove the shaft seal (Item 1) [Figure 30-20-38].

Replace the outer O-ring and inner shaft seal (Item 2) [Figure 30-20-38].

Remove the bearing cup (Item 3) [Figure 30-20-38] if it needs replacement.

Inspection

Figure 30-20-39

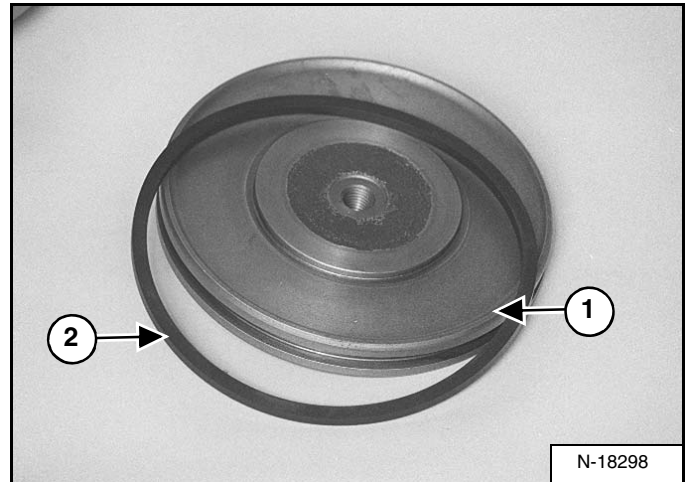

Clean all parts in clean solvent and use air pressure to dry them. Do Not use cloth or paper because small pieces of material can get into the system and cause damage.

Before the motor is assembled, check the following items:

Check the brake piston (Item 1) [Figure 30-20-39] and seal (Item 2) [Figure 30-20-39] and replace as needed.

Figure 30-20-40

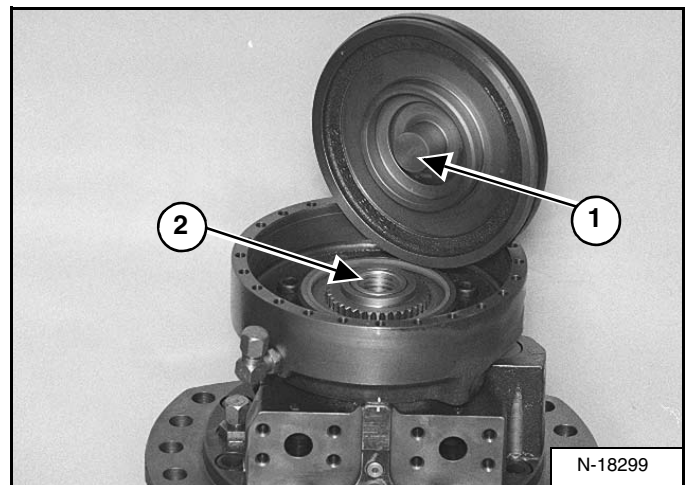

Check the piston surface (Item 1) [Figure 30-20-40] and the bushing surface (Item 2) [Figure 30-20-40] in the brake shaft.

NOTE: The bushing (Item 2) [Figure 30-20-40] can be replaced in the brake shaft.



Bobcat®

HYDROSTATIC PUMP (CONT'D)

Parts Identification (Left Half) (Cont'd)

| Ref. | Description | Ref. | Description |
|-------------|--------------------|-------------|--------------------|
| 1. | SNAP RING | 34. | WASHER |
| 2. | WASHER | 35. | SPRING |
| 3. | SEAL | 36. | WASHER |
| 4. | SNAP RING | 37. | WASHER |
| 5. | SNAP RING | 38. | VALVE PLATE |
| 6. | BEARING | 39. | PIN |
| 7. | SNAP RING | 40. | GASKET |
| 8. | KEY | 41. | BEARING |
| 9. | SHAFT | 42. | PLUG |
| 10. | HOUSING | 43. | POPPET |
| 11. | PLUG | 44. | SPRING |
| 12. | O-RING | 45. | SHIM |
| 13. | BEARING | 46. | O-RING |
| 14. | SEAL | 47. | PLUG |
| 15. | O-RING | 48. | PLUG |
| 16. | COVER | 49. | O-RING |
| 17. | BOLT | 50. | O-RING |
| 18. | PIN | 51. | O-RING |
| 19. | O-RING | 52. | RELIEF VALVE |
| 20. | PLUG | 53. | PLUG |
| 21. | BEARING | 54. | PIN |
| 22. | O-RING | 55. | O-RINGS |
| 23. | PLATE | 56. | PIN |
| 24. | BOLT | 57. | GEROTOR |
| 25. | SWASH PLATE | 58. | SPACER |
| 26. | WEAR PLATE | 59. | O-RING |
| 27. | PISTON ASSEMBLY | 60. | O-RING |
| 28. | PISTON RETAINER | 61. | PIN |
| 29. | RETAINER | 62. | COUPLER |
| 30. | WASHER | 63. | BOLT |
| 31. | PIN | 64. | O-RING |
| 32. | RETAINER | 65. | O-RING |
| 33. | BLOCK | 66. | RELIEF VALVE |

HYDROSTATIC PUMP (CONT'D)

Assembly

Figure 30-40-46

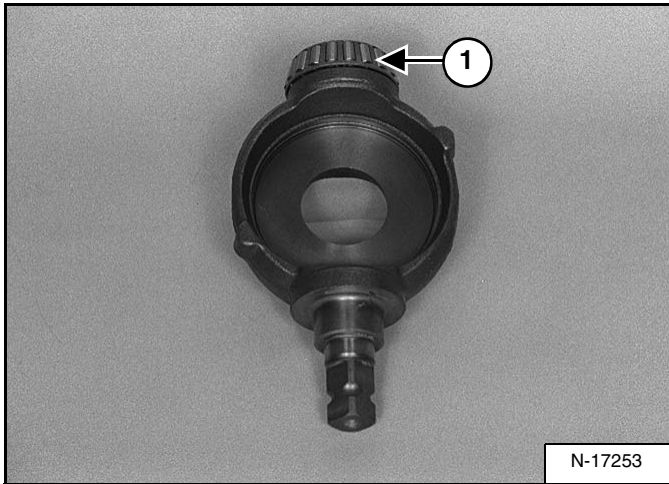

Install the lower bearing (Item 1) [Figure 30-40-46] on the swashplate.

Figure 30-40-47

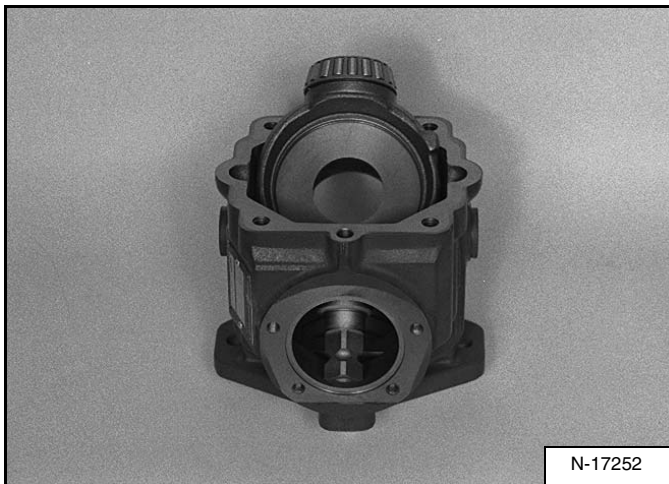

Install the swashplate and bearing into the pump housing [Figure 30-40-47].

Figure 30-40-48

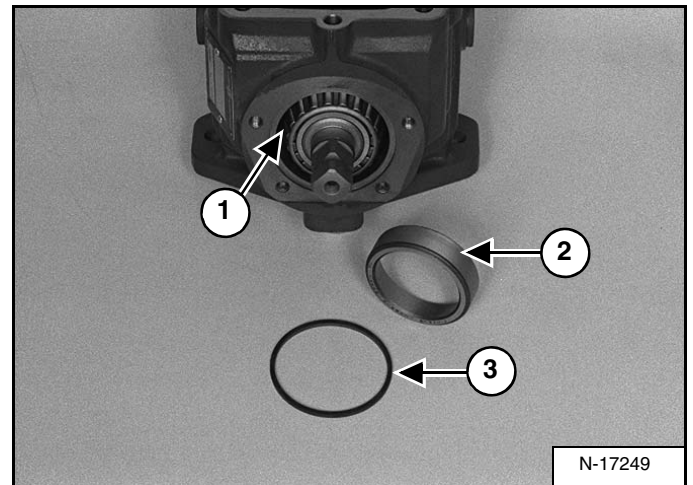

Install the tapered bearing (Item 1) [Figure 30-40-48] on the swashplate shaft.

Figure 30-40-49

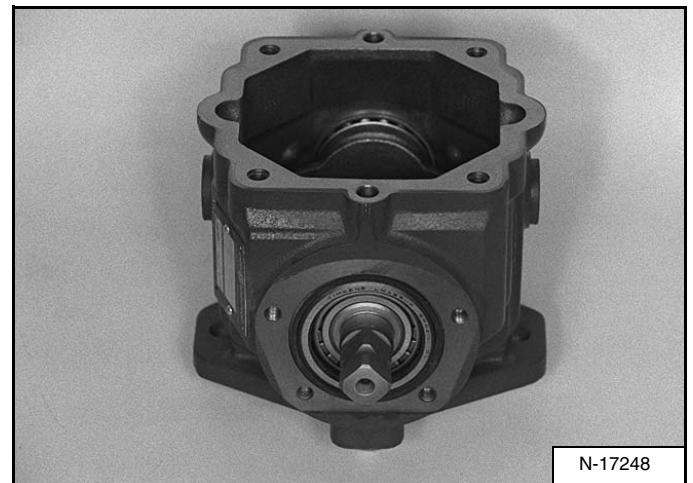

Install the bearing race (Item 2) [Figure 30-40-48] and O-ring (Item 3) [Figure 30-40-48] as shown in [Figure 30-40-49].

DRIVE BELT (CONT'D)

Tensioner Pulley Removal And Installation

Figure 30-50-7

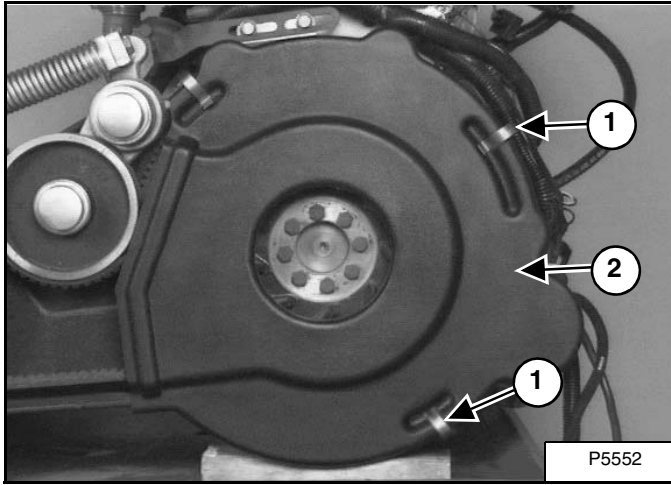

Remove the belt shield clips (Item 1) [Figure 30-50-7].

Remove the belt shield (Item 2)[Figure 30-50-7].

Figure 30-50-8

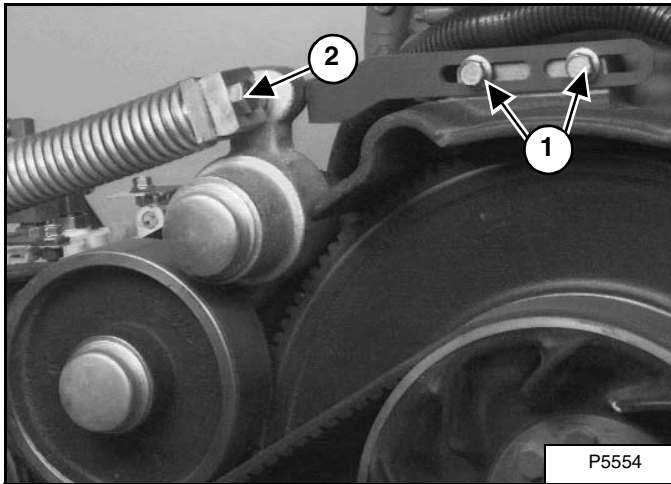

Remove the two stop mounting bolts (Item 1) [Figure 30-50-8].

Remove the stop.

Remove the spring tension bolt (Item 2) [Figure 30-50-8].

Figure 30-50-9

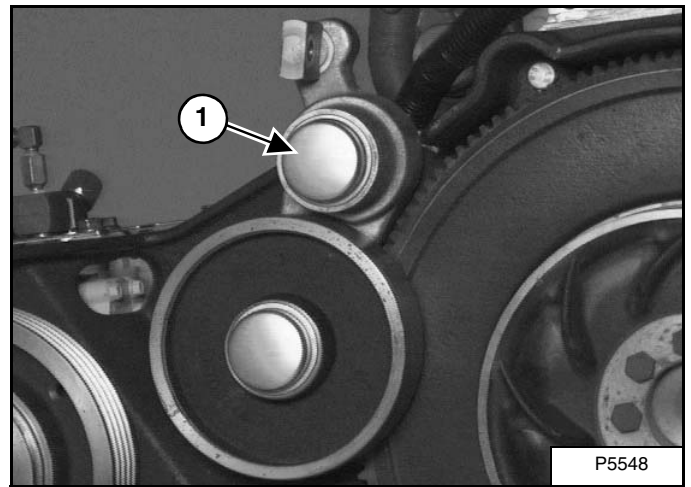

Remove the end cap (Item 1) [Figure 30-50-9] from the tensioner pulley arm.

Figure 30-50-10

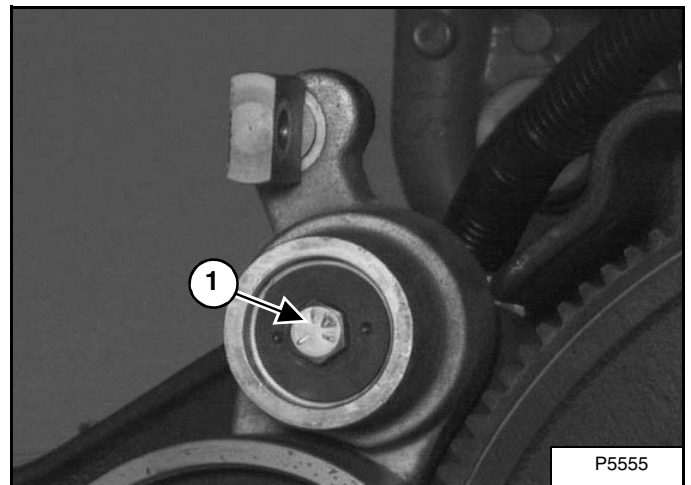

Remove the mounting bolt (Item 1) [Figure 30-50-10] from the tensioner pulley arm.

BRAKE (CONT'D)

Block Removal And Installation (Cont'd)

Figure 40-10-7

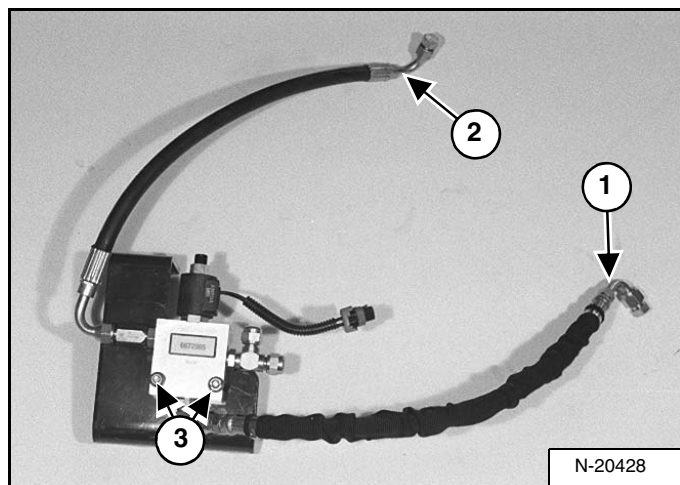

Remove the hoses (Item 1) [Figure 40-10-7] from the block.

Remove the hose (Item 2) [Figure 40-10-7] from the block.

Remove the two mount bolts (Item 3) [Figure 40-10-7] and nuts.

Remove the block from the mount.

DRIVE COMPONENTS (CONT'D)

Track Removal And Installation (Cont'd)

Figure 40-20-15

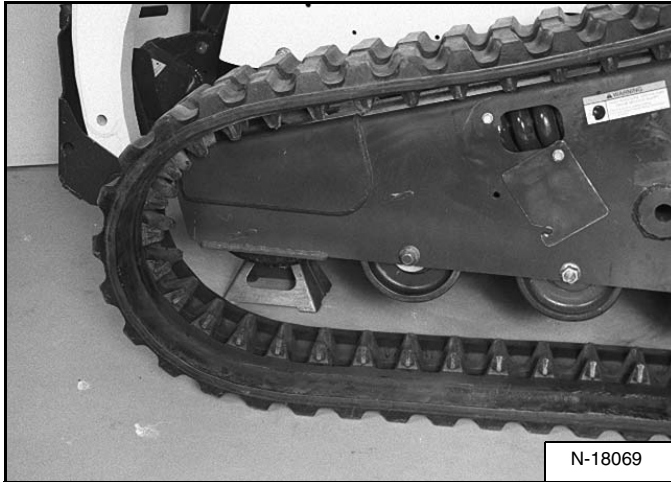

NOTE: To protect your hands from injury always wear gloves before removal or installation of the track.

Completely remove the track from the front track assembly [Figure 40-20-15].

Figure 40-20-16

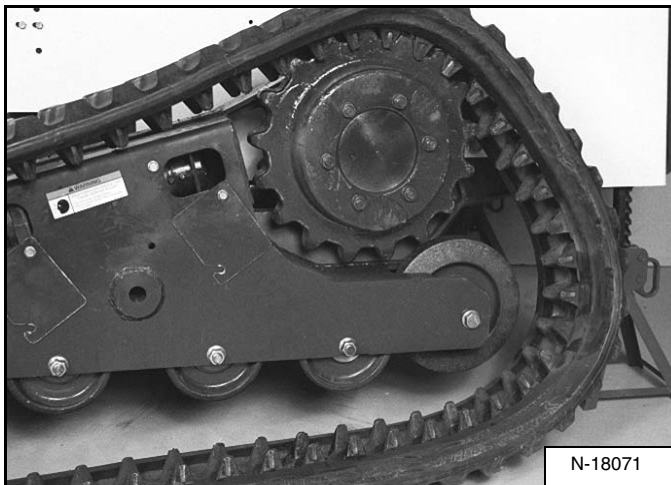

With a pry bar slide the track clear of the rear idler [Figure 40-20-16].

Figure 40-20-17



With a chain hoist or arm hoist lift the track clear of the drive sprocket and remove the track from the loader [Figure 40-20-17].

To install the rubber track:

Completely retracted the front idler / spring assembly.

Put the track over the rear drive sprocket lugs.

Put the track over the rear idler.

Slide the track under the rollers.

Put the track on the front idler wheel.

Adjust the track to the proper tension.(See Track Checking on Page 40-20-1.)

NOTE: The grease cylinder must be completely retracted against the spring assembly block before adding grease, to prevent air from being trapped in the grease cylinder.

DRIVE COMPONENTS (CONT'D)

Track Idler (Rear) Disassembly (S/N 518916540 & Below)

Figure 40-20-40

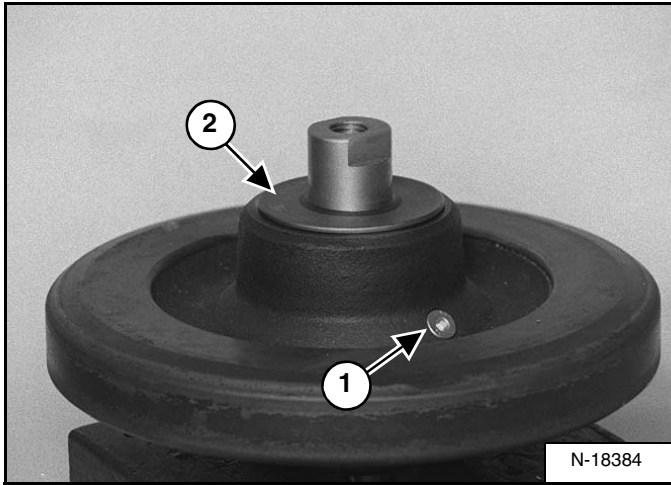

Remove the oil drain plug (Item 1) [Figure 40-20-40] from the rear idler.

Drain the oil from the idler.

Remove seal (Item 2) [Figure 40-20-40]. (Both sides of the rear idler.)

Figure 40-20-41

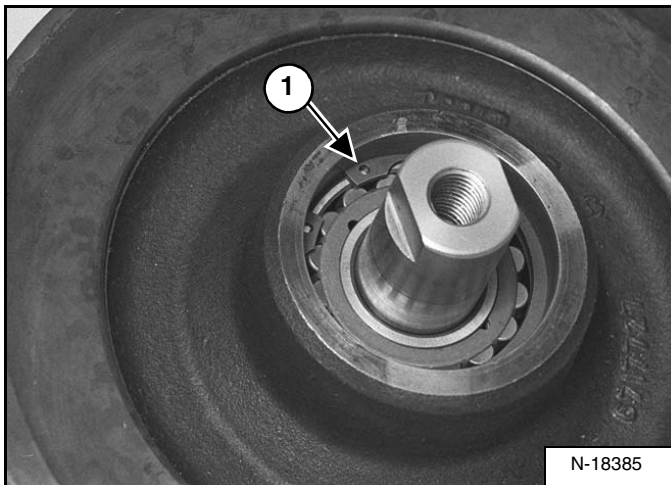

Remove the snap ring (Item 1) [Figure 40-20-41]. (Both sides of the rear idler.)

Figure 40-20-42

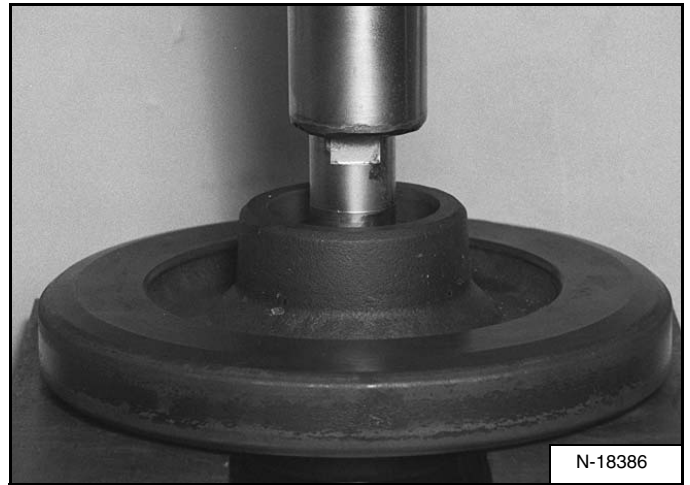

In a press, press the axle shaft and one bearing from the rear idler [Figure 40-20-42].

Figure 40-20-43

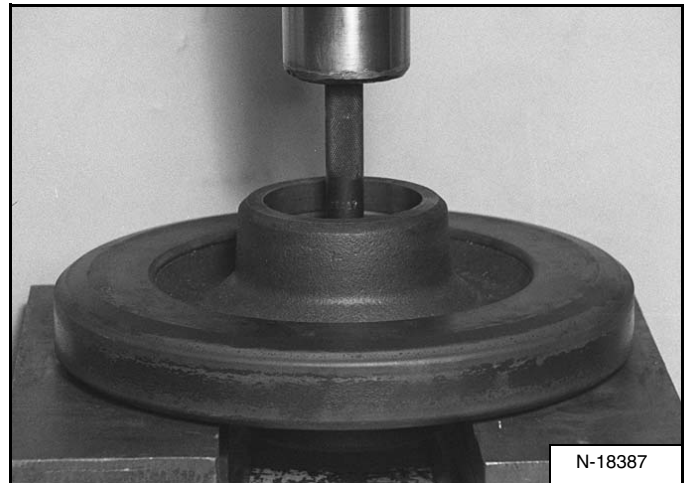

Turn the rear idler over and press the old bearing out [Figure 40-20-43].

Check the idler and replace as needed.

DRIVE COMPONENTS (CONT'D)

Track Idler (Front) Assembly (S/N 518916541 & Above) (Cont'd)

Figure 40-20-71

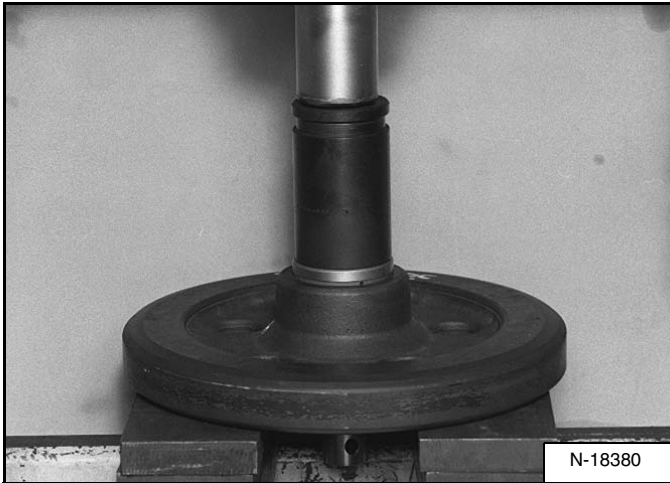

Place the idler, bearing, and axle shaft assembly in a press.

Using a bearing driver tool, press a new bearing over the axle shaft into the front idler [Figure 40-20-71].

Figure 40-20-72

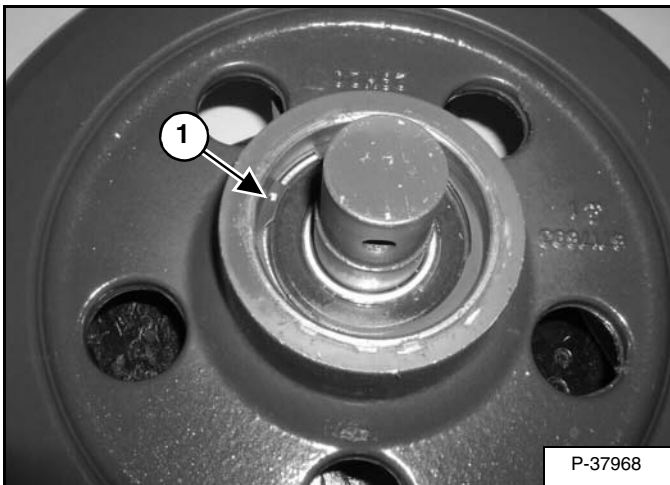

Install the snap ring (Item 1) [Figure 40-20-72].

Figure 40-20-73

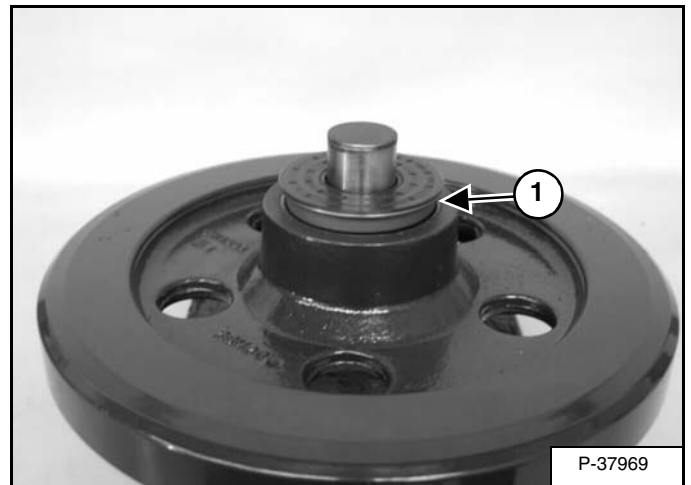

With a seal driver, install the seal (Item 1) [Figure 40-20-73] into the idler. (Both sides.)

NOTE: The seals must be installed, so they are seated against the hub of the idler without distorting the seal surface.

Figure 40-20-74

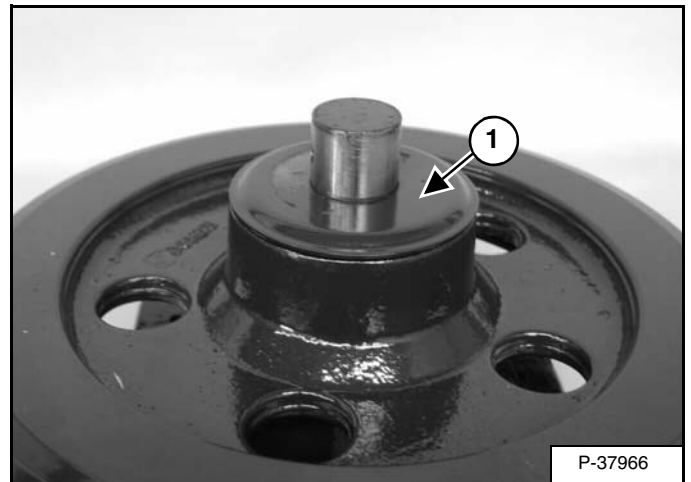

Install the seal cover (Item 1) [Figure 40-20-74] on the idler axle shaft. (Both sides of the idler.)

DRIVE COMPONENTS (CONT'D)

Track Housing Removal And Installation

Figure 40-20-102

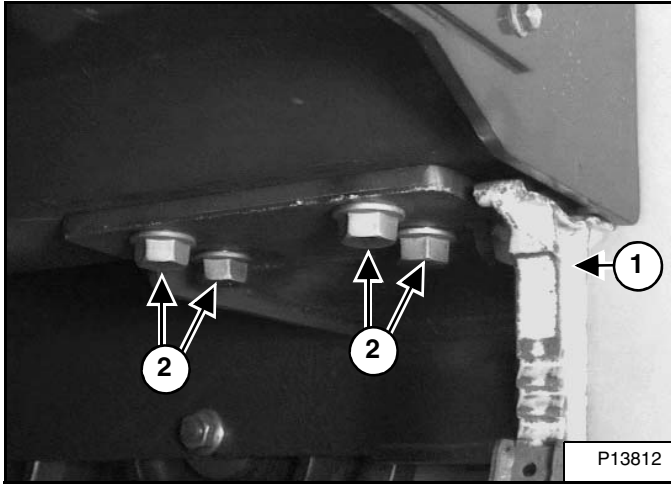

Lift and block the loader. (See LIFTING AND BLOCKING THE LOADER on Page 10-10-1.)

NOTE: Position the jackstand (Item 1) [Figure 40-20-102] at the front of the loader to allow for track housing removal.

Remove the track from the loader. (See Track Removal And Installation on Page 40-20-3.)

Remove the hydrostatic motor from the track housing. (See HYDROSTATIC MOTOR on Page 30-20-1.)

Support the track housing.

Remove the four mounting bolts (Item 2) [Figure 40-20-102] from the track housing mount plate. (At the front and rear of the loader.)

Figure 40-20-103

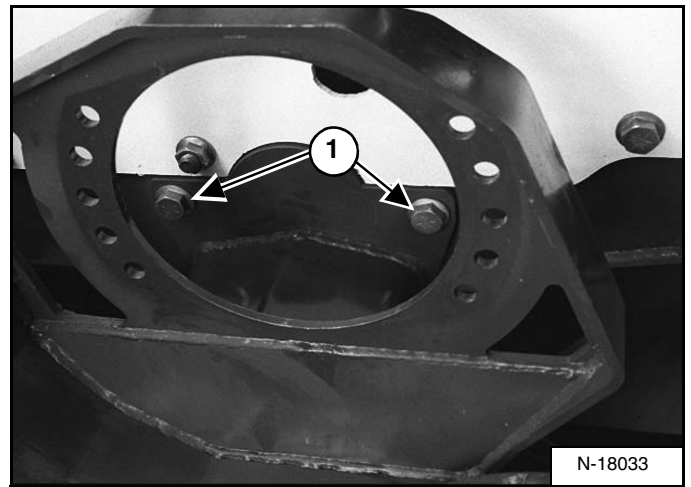

At the rear of the loader remove the two mount bolts (Item 1) [Figure 40-20-103].

Figure 40-20-104

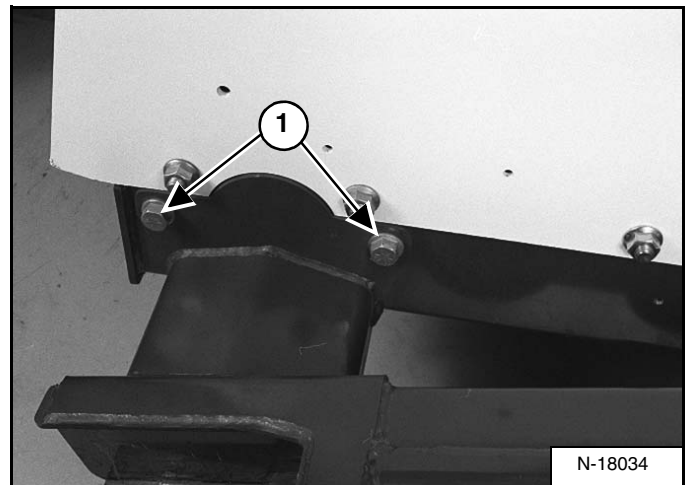

Remove the two mounting bolts (Item 1) [Figure 40-20-104].

Remove the track housing from the loader.

Installation: Tighten the twelve mounting bolts to 330 ft.-lb. (447,5 N•m) torque.

DRIVE COMPONENTS (CONT'D)

Track Damage Identification (Cont'd)

Figure 40-20-128

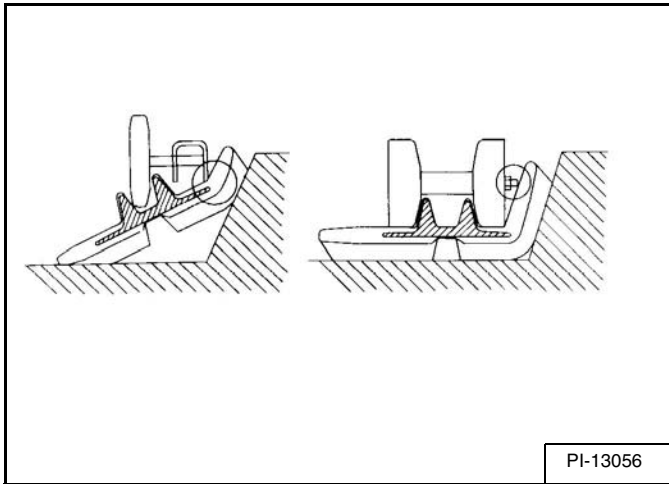
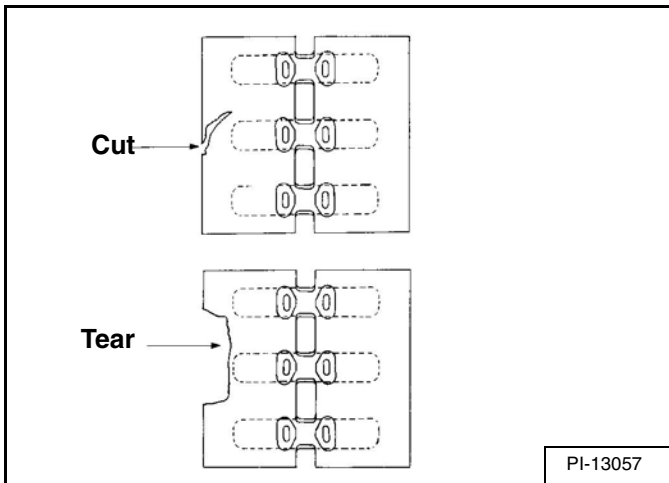

Figure 40-20-129



In case of damage by objects on the operating ground:

The edges of rubber track are often deformed largely due to a bumpy ground surface, stones and other objects, which cause extensive stress on the edges resulting in the damage. Especially, when a machine drives over concrete ridges, this type of damage easily occurs [Figure 40-20-128].

In case of damage by interference with the machine frame

If a machine continues operating with rubber tracks being detracted, the rubber tracks may get caught up in the machine frame or undercarriage parts resulting in damage. Furthermore, when a machine travels along side slopes, the rubber tracks are deformed so much that they come into contact with the machine frame and undercarriage parts, which causes cutting, gouging and rubbing of rubber tracks in the end [Figure 40-20-129].

Prevention:

When traveling, a machine operator should be careful not to drive over any projections on the ground. He should also prevent rubber tracks from coming into contact with concrete walls, ditches and ridges. If rubber tracks are detracted, the machine should be stopped immediately for retracting.

OPERATOR CAB (CONT'D)

Removal And Installation

Figure 50-20-8

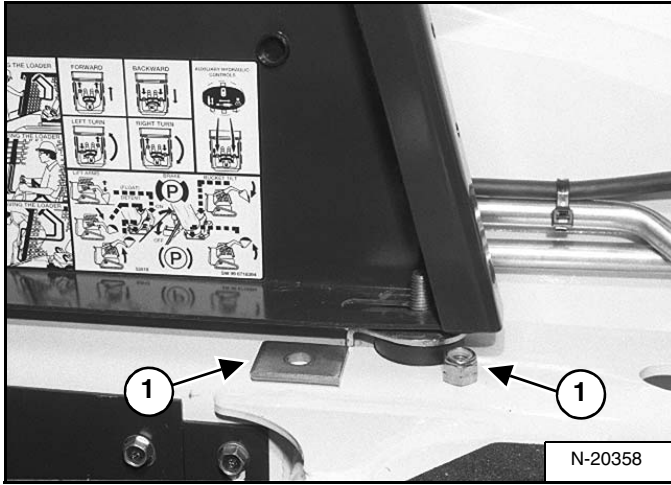

Remove the cab nut and holddown plate (Item 1) [Figure 50-20-8] (both sides).

Installation: Tighten the nut to 40 - 50 ft.-lb. (54 - 68 N•m) torque.

Figure 50-20-9

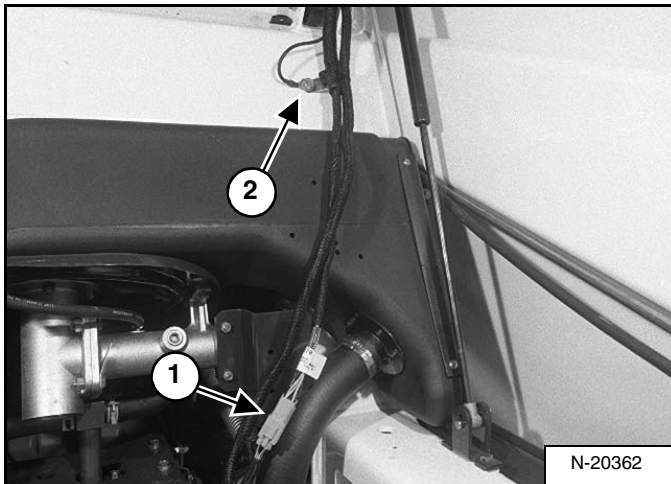

Disconnect the wiring harness connector (Item 1) [Figure 50-20-9].

Disconnect the operator cab ground wire (Item 2) [Figure 50-20-9].

Figure 50-20-10

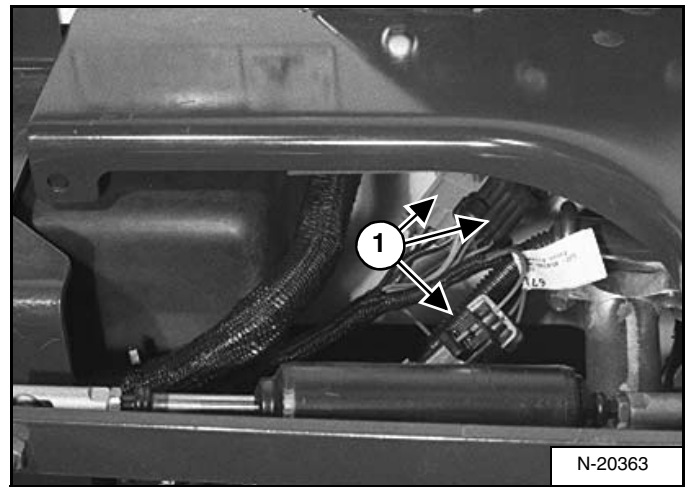

Disconnect the three wiring connectors (Item 1) [Figure 50-20-10] at the left steering lever.

Figure 50-20-11

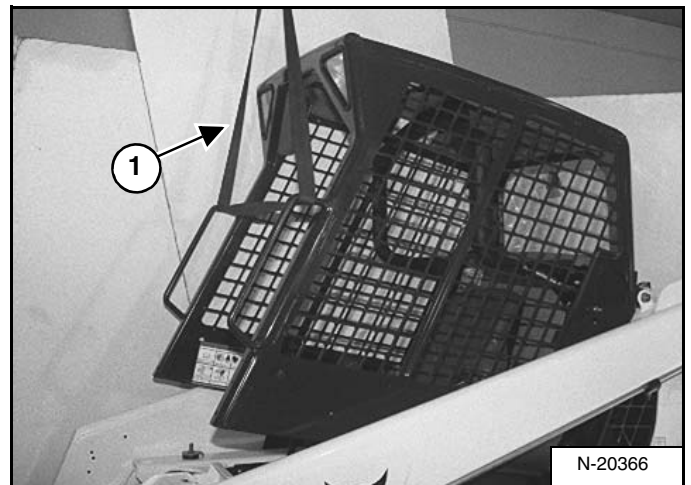

Install a sling (Item 1) [Figure 50-20-11] on the grab handles of the operator cab. Connect a chain hoist to the sling.

Remove both gas cylinders. (See Gas Cylinder Removal And Installation 50-20-1.)

After the gas cylinders are removed, lower the operator cab using the chain hoist.

CLICK HERE TO **DOWNLOAD** THE COMPLETE MANUAL

- Thank you very much for reading the preview of the manual.
- You can download the complete manual from: www.heydownloads.com by clicking the link below



- Please note: If there is no response to CLICKING the link, please download this PDF first and then click on it.

CLICK HERE TO **DOWNLOAD** THE COMPLETE MANUAL

BOB-TACH (CONT'D)

Bob-Tach Lever And Wedge (Cont'd)

Figure 50-40-7

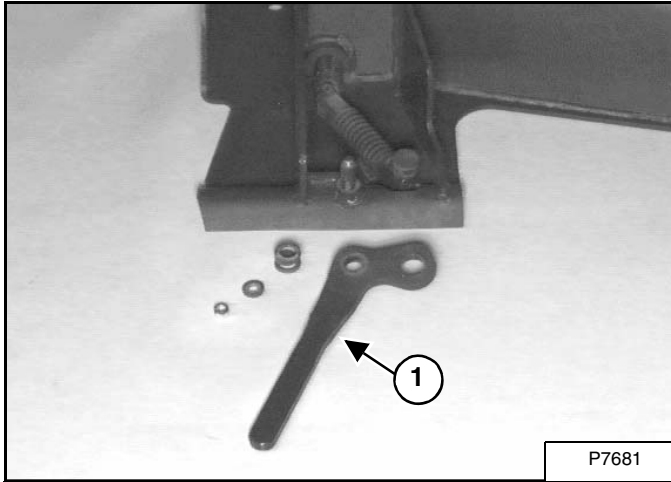

Remove the Bob-Tach lever (Item 1) [Figure 50-40-7].

Figure 50-40-8

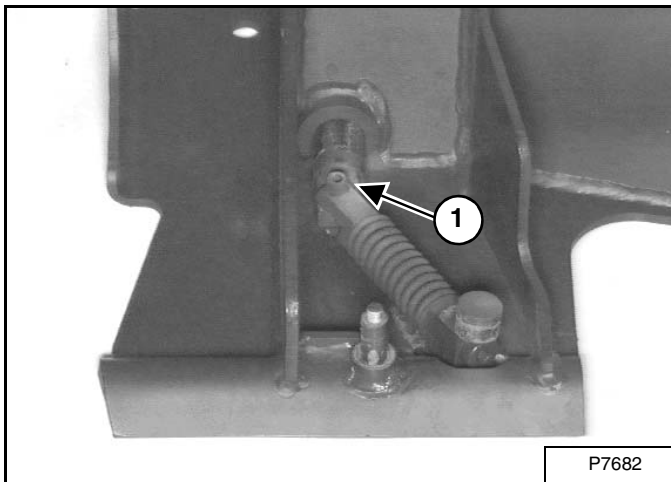

Remove the roll pin (Item 1) [Figure 50-40-8] from the Bob-Tach wedge assembly.

Figure 50-40-9

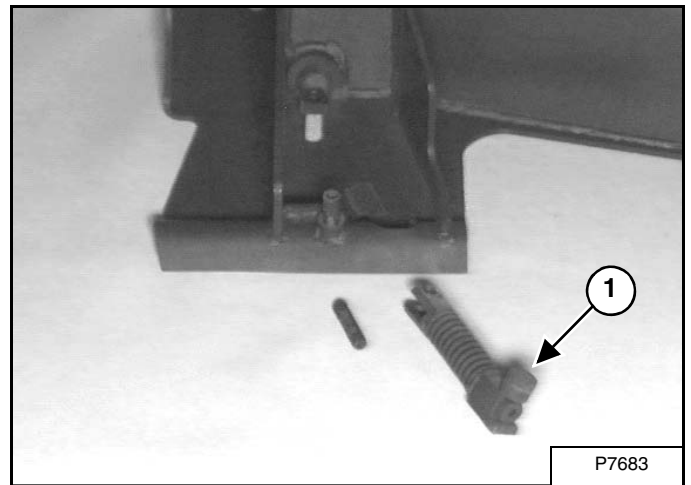

Remove the spring, bolt and clevis assembly (Item 1) [Figure 50-40-9].

Remove the wedge from the Bob-Tach frame.

Always replace bent or broken wedges.

Figure 50-40-10

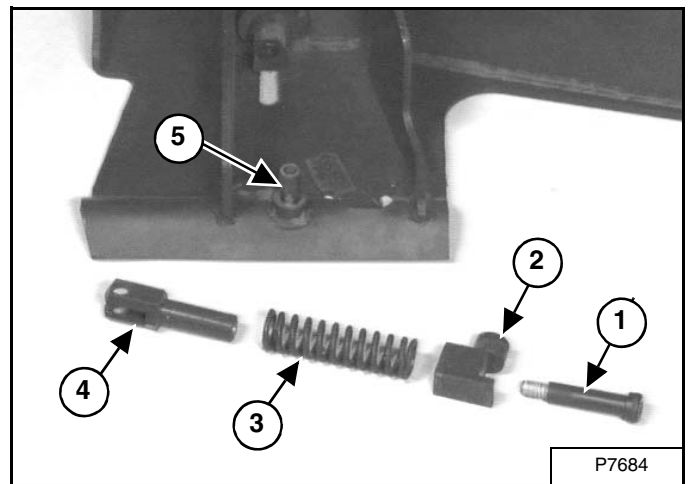

If the bolt (Item 1) [Figure 50-40-10], handle pivot (Item 2) [Figure 50-40-10], spring (Item 3) [Figure 50-40-10] or clevis (Item 4) [Figure 50-40-10] are damaged, put the assembly in the vise for disassembly. Loosen and remove the bolt (Item 1) [Figure 50-40-10] with a 5/16 in. allen wrench.

Replace the worn or damaged parts as needed.

Before installation of the parts, put grease on the handle pivot (Item 2) [Figure 50-40-10], Bob-Tach handle pivot (Item 5) [Figure 50-40-10], and bolt (Item 1) [Figure 50-40-10].

Reverse the removal procedure to install the Bob-Tach lever and wedge assembly.

LIFT ARMS

Removal And Installation

Figure 50-50-1

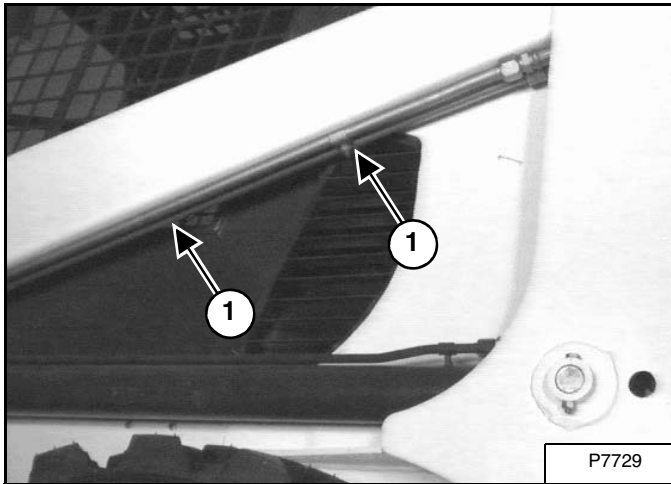

The items listed are necessary for the following procedure:

Three Lifting Straps - 7 ft. in length (with looped ends)
Chain Hoist

Install jackstands under the rear corners of the loader.

Remove the Bob-Tach from the lift arms. (See Removal And Installation on Page 50-40-4.)

Remove the two auxiliary tubeline clamps (Item 1) [Figure 50-50-1] from the left lift arm (if so equipped).

Figure 50-50-2

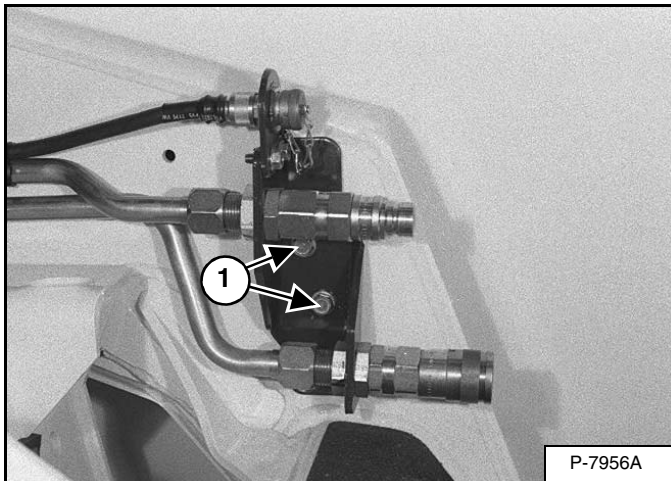

Remove the two mounting bolts (Item 1) [Figure 50-50-2] from the front auxiliary quick coupler mounting bracket (if so equipped).

Figure 50-50-3

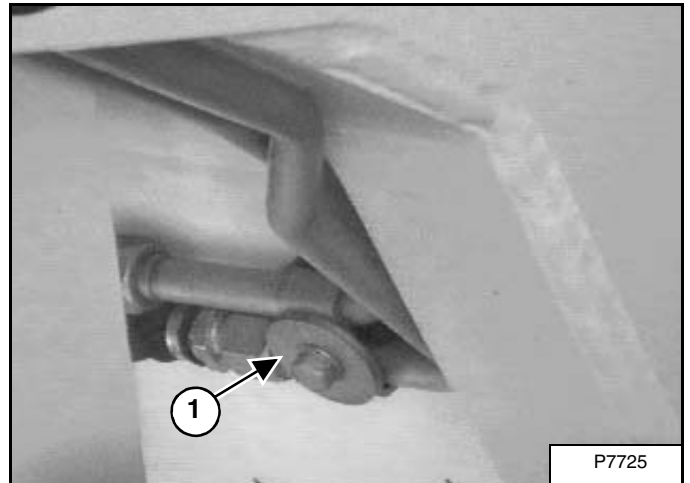

Remove the tilt tubeline mounting clamp (Item 1) [Figure 50-50-3] from the back of the lift arm crossmember.

Raise the operator cab. (See Raising The Operator Cab on Page 10-30-1.)

NOTE: Procedure shown is on 863, but is the same for T200.

Figure 50-50-4

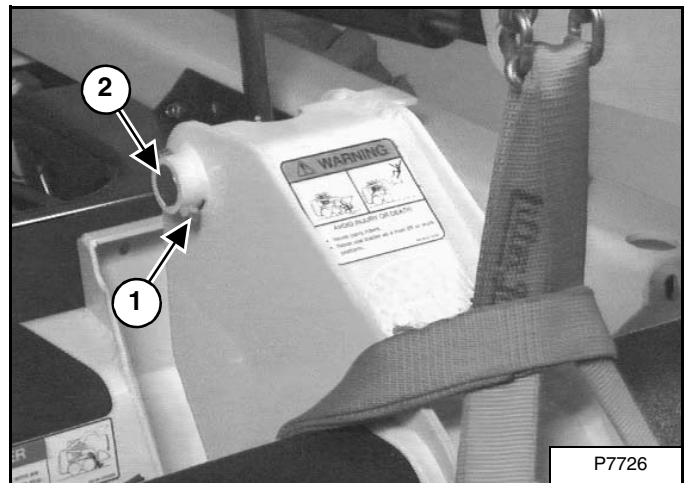

Wrap the lifting strap around the lift arm crossmember as shown in Figure [Figure 50-50-4]. Connect both loops of the lifting strap to a chain hoist.

Raise the lift arms enough to remove the auxiliary tubelines (if so equipped) from the lift arms [Figure 50-50-5].

Remove the nut and retainer bolt (Item 1) [Figure 50-50-4] from the pivot pin for the base of the tilt cylinder.

Remove the pivot pin from the base end of the tilt cylinder (Item 2) [Figure 50-50-4].

FUEL TANK

Removal And Installation

Figure 50-80-1

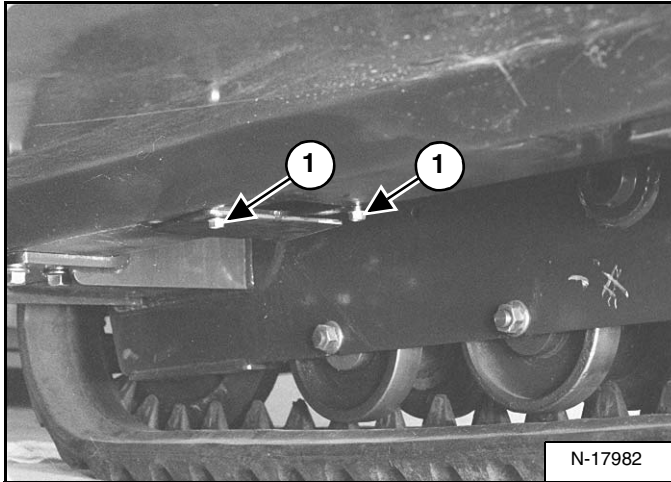

Loosen the bolts (Item 1) [Figure 50-80-1] on the access cover located under the main frame at the left side of the loader.

Pivot the access cover to expose the drain plug on the fuel tank [Figure 50-80-1].

Figure 50-80-2

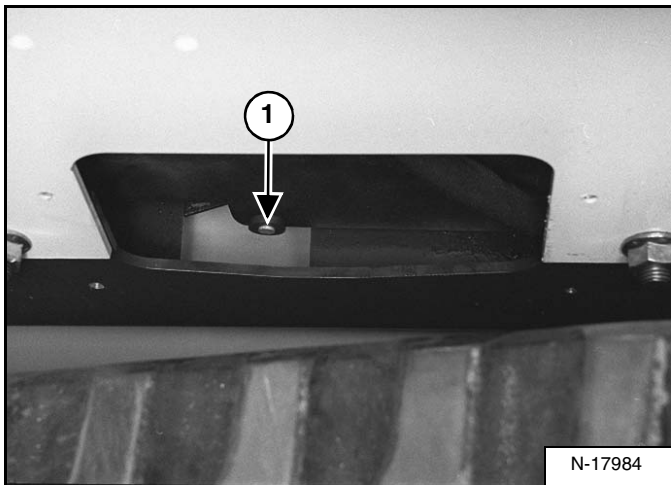

Remove the access cover at the left side of the loader [Figure 50-80-2].

Remove the drain plug (Item 1) [Figure 50-80-2].

Dispose of the fuel in an environmentally safe manner.

Remove the control panel. (See CONTROL PANEL on Page 50-100-1.)

Remove the hydraulic control valve. See Removal And Installation (S/N 518915181 & Below) on Page 20-41-3. See Removal And Installation (S/N 518915182 & Above) on Page 20-41-12.

Remove the hydraulic reservoir. (See Removal And Installation on Page 20-80-1.)

Figure 50-80-3

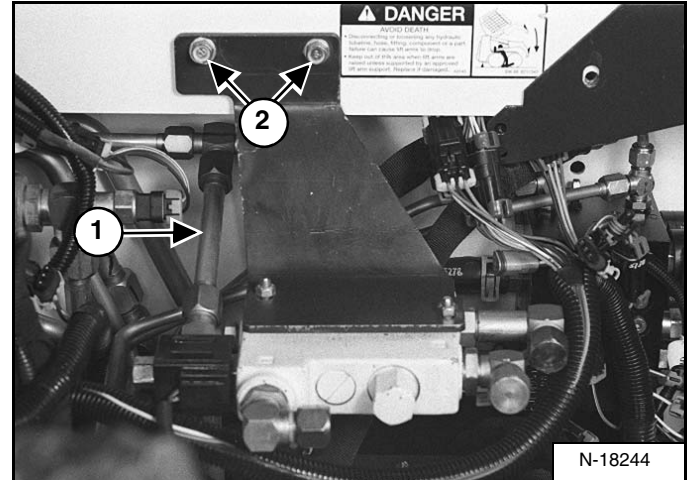

Disconnect the bucket position tube line (Item 1) [Figure 50-80-3].

Disconnect the electrical connection to the solenoid.

Remove the two mount bolts (Item 2) [Figure 50-80-3].

Remove the bucket position valve and mount bracket from the loader.

Figure 50-80-4

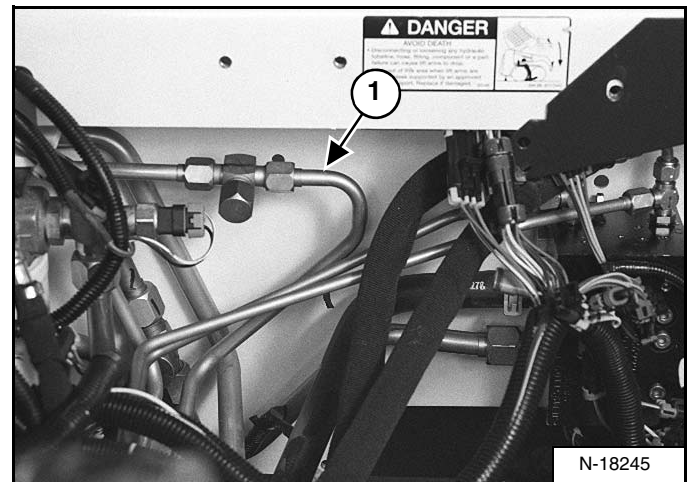

Remove the lift tubeline (Item 1) [Figure 50-80-4].

CONTROL HANDLE

Shock Removal And Installation

Figure 50-110-1

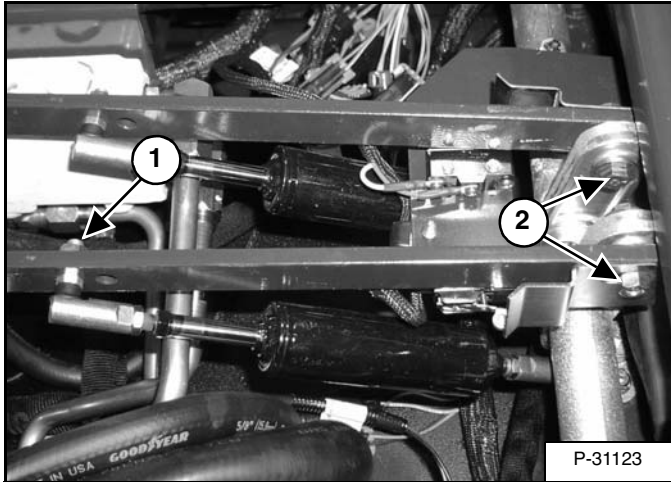

Remove the mounting nut (Item 1) [Figure 50-110-1] from the end of the shock connected to the steering linkage.

Figure 50-110-2

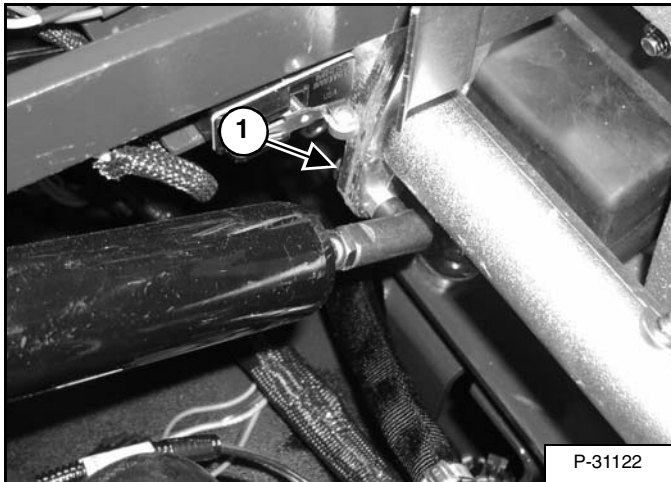

Remove the mounting nut (Item 1) [Figure 50-110-2] from the other end of the shock connected to the bellcrank on the steering shaft.

Remove the shock from the loader.

Installation: Tighten the mounting bolts to 25 - 28 ft.-lb. (34 - 38 N•m) torque.

Shaft Removal And Installation

NOTE: The steering shaft can be removed without removing the control panel from the loader. Photo [Figure 50-110-3] shows the control panel removed for clarity purpose only.

Figure 50-110-3

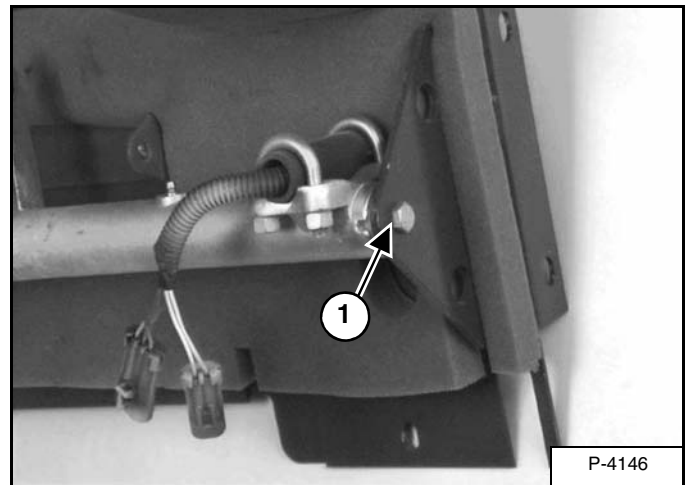

Remove the steering linkage mounting bolts (Item 2) [Figure 50-110-1].

Remove the steering shock. (See above procedure).

Remove the steering shaft pivot bolt (Item 1) [Figure 50-110-3] from both sides of the control panel.

Installation: Tighten the pivot bolts to 180 - 200 in.-lb. (21 - 23 N•m) torque.

Remove the steering shaft from the control panel.

CONTROL HANDLE (CONT'D)

Linkage Neutral Adjustment (Cont'd)

Figure 50-110-31

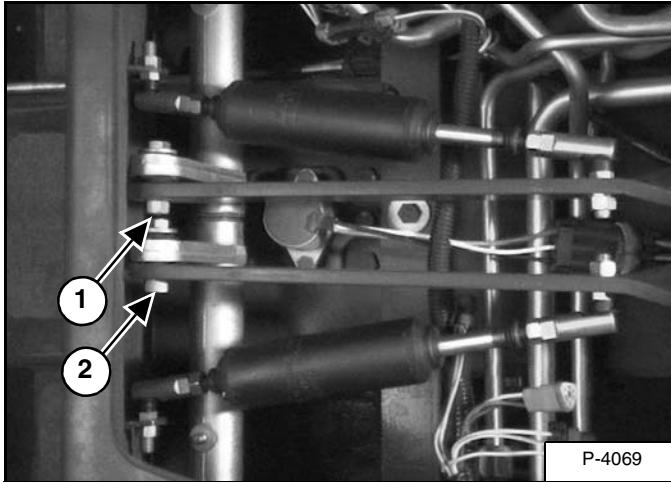

Tighten the two bolts to 11 - 13 ft.-lb. (15 - 17 N•m) torque, then tighten the two nuts to 21 - 25 ft.-lb. (28 - 33 N•m) torque at the steering cross shaft (Items 1 & 2) **[Figure 50-110-31]**.

Remove the service shield. Install the fan drive belt.

Install both access covers.

CONTROL HANDLE (ADVANCED CONTROL SYSTEM) (ACS) SELECTABLE HAND / FOOT CONTROL

Components Identification

Figure 50-112-1

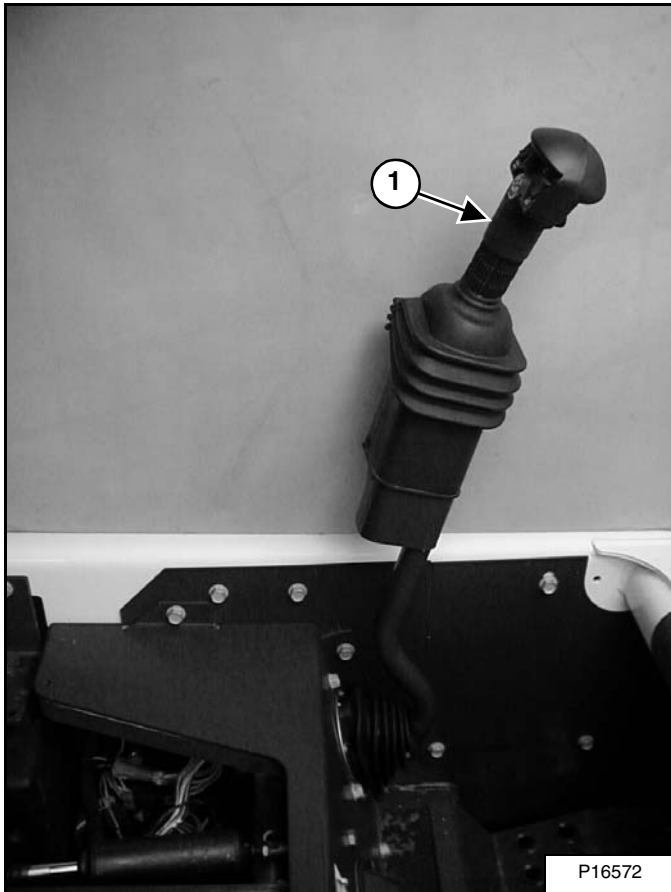

Control Handle (Item 1) [Figure 50-112-1].

Figure 50-112-2

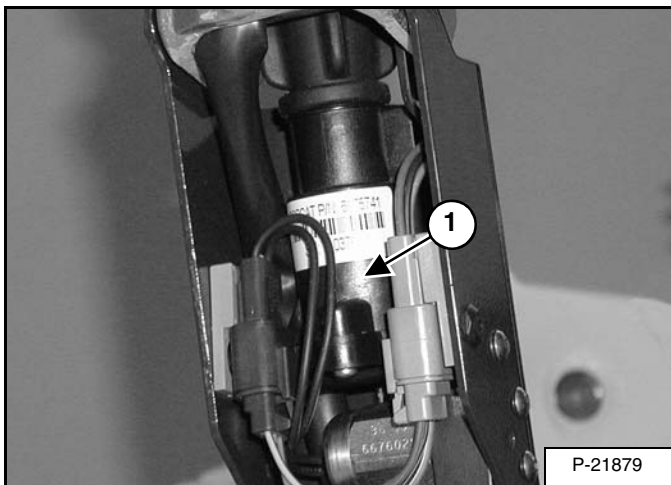

Handle Sensor (Item 1) [Figure 50-112-2].

Handle Sensor Removal And Installation

Figure 50-112-3

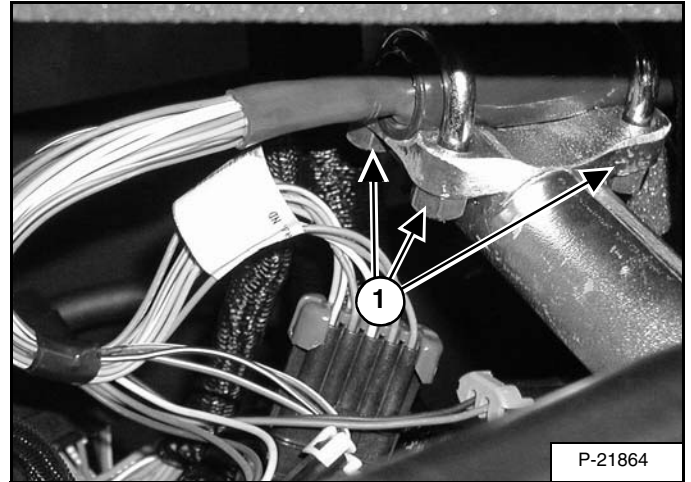

Loosen the nuts (Item 1) [Figure 50-112-3].

Installation: Tighten the u-bolts so the lever can not be moved either right or left when seated in the operator seat. Be sure the control lever does not interfere with the operator cab when lowering or raising the cab.

Figure 50-112-4

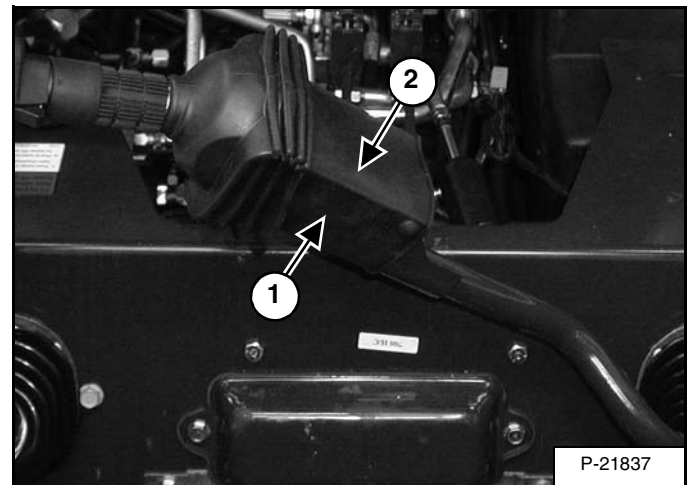

Tilt the control handle (Item 1) [Figure 50-112-4] to the center of the loader.

Lift the boot cover (Item 2) [Figure 50-112-4].

ELECTRICAL SYSTEM & ANALYSIS (CONT'D)

| | |
|--|----------|
| ELECTRICAL SYSTEM INFORMATION | 60-10-1 |
| Description | 60-10-4 |
| Fuse Location | 60-10-6 |
| Relay Switch Location | 60-10-6 |
| Solenoid Test | 60-10-7 |
| Troubleshooting Chart | 60-10-3 |
| INSTRUMENT PANEL | 60-50-1 |
| Deluxe Panel Removal And Installation (Right Side) | 60-50-10 |
| Front Accessory Panel Removal And Installation | 60-50-12 |
| Left Panel (Standard) | 60-50-1 |
| Option And Field Accessory Panels | 60-50-8 |
| Passwords | 60-50-6 |
| Right Panel (Deluxe) (With Keyless Start) | 60-50-3 |
| Right Panel Setup Display Options (Deluxe) | 60-50-5 |
| Right Panel-Standard Instrument Panel (With Key Switch) | 60-50-2 |
| Standard And Deluxe Panel Removal And Installation (Left Side) | 60-50-11 |
| Standard Panel Removal And Installation (Right Side) | 60-50-9 |
| LIGHTS | 60-60-1 |
| Front Removal And Installation | 60-60-1 |
| Rear Removal And Installation | 60-60-2 |
| SEAT BAR SENSOR | 60-100-1 |
| BICS™ Circuit Test | 60-100-4 |
| Removal And Installation | 60-100-3 |
| Test | 60-100-2 |
| Troubleshooting Chart | 60-100-1 |
| STARTER (NIPPONDENSO) | 60-40-1 |
| Disassembly And Assembly | 60-40-3 |
| External Pinion | 60-40-6 |
| Inspection And Repair | 60-40-7 |
| No Load Test | 60-40-11 |
| Parts Identification | 60-40-2 |
| Removal And Installation | 60-40-1 |
| TRACTION LOCK | 60-110-1 |
| Description Of The Control System | 60-110-2 |
| Inspecting The Control System | 60-110-2 |
| Parking Brake Solenoid Removal And Installation (S/N 518916040 & Below) | 60-110-3 |
| Traction Lock Bypass Knob | 60-110-5 |
| Troubleshooting Chart | 60-110-1 |

ELECTRICAL SYSTEM INFORMATION (CONT'D)

Description

Figure 60-10-1

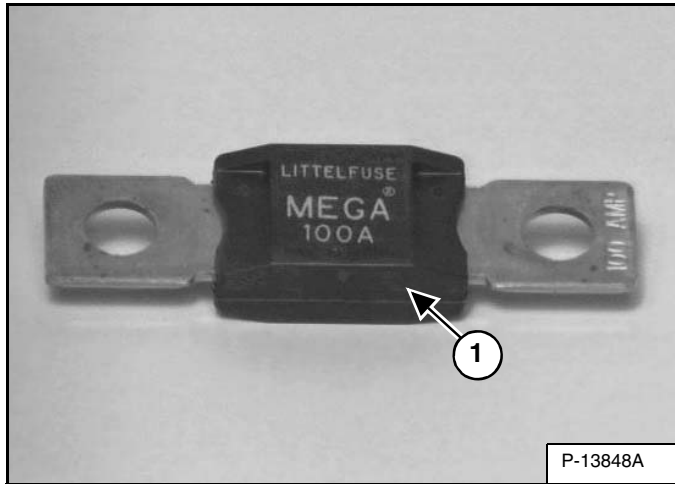

The loader has a 12 volt, negative ground alternator charging system. The electrical system is protected by a 100 amp master fuse (Item 1) [Figure 60-10-1], to protect against serious system overloads that could lead to burned up harness or loader damage.

Figure 60-10-2

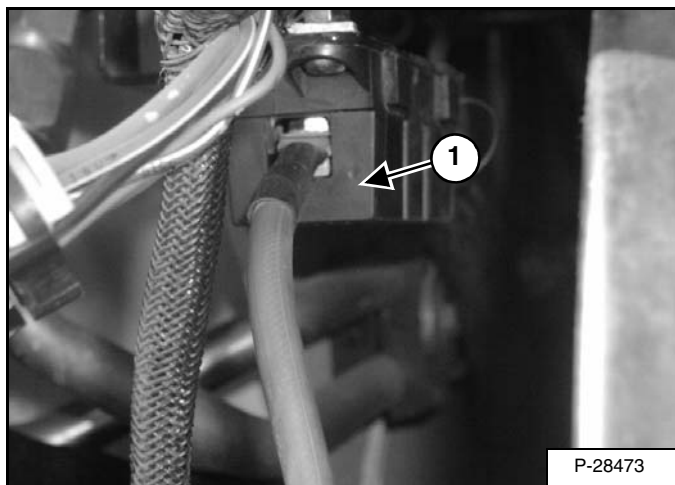
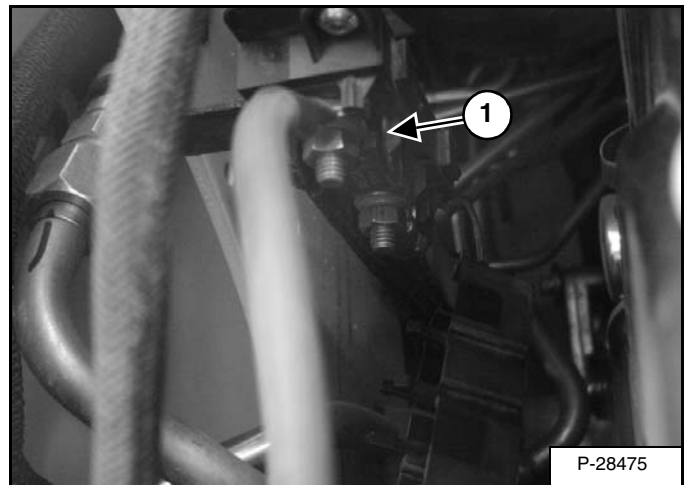
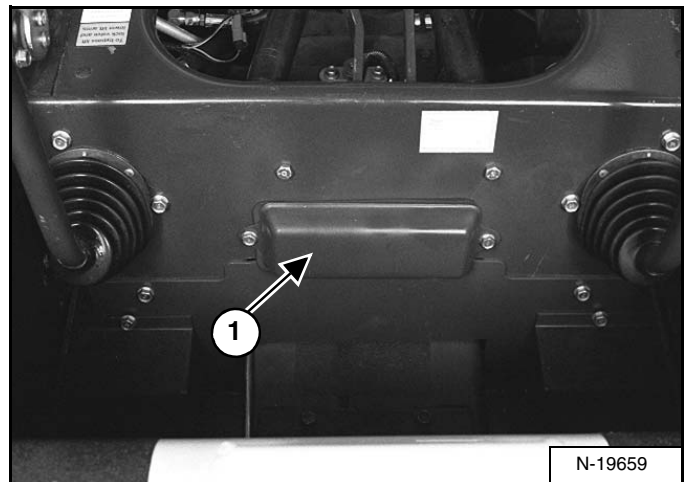

Figure 60-10-3



The fuse holder is located in the engine compartment, below the engine harness connector (Item 1) [Figure 60-10-2] & [Figure 60-10-3].

Figure 60-10-4



The electrical system is also protected by fuses and relays under the fuse panel cover (Item 1) [Figure 60-10-4] located in the cab on the steering control panel.

IMPORTANT

Do Not use silicone base sprays and/or sealants on harness connectors or components.

I-2123-0397

ALTERNATOR (90 AMP) (CONT'D)

Charging System Check

! WARNING

AVOID INJURY OR DEATH

Batteries contain acid which burns eyes and skin on contact. Wear goggles, protective clothing and rubber gloves to keep acid off body.

In case of acid contact, wash immediately with water. In case of eye contact get prompt medical attention and wash eye with clean, cool water for at least 15 minutes.

If electrolyte is taken internally drink large quantities of water or milk! DO NOT induce vomiting. Get prompt medical attention.

W-2065-0807

! WARNING

AVOID INJURY OR DEATH

Keep arcs, sparks flames and lighted tobacco away from batteries. When *jumping* from booster battery make final connection (negative) at machine frame.

Do not jump start or charge a frozen or damaged battery. Warm battery to 60°F (16°C) before connecting to a charger. Unplug charger before connecting or disconnecting cables to battery. Never lean over battery while boosting, testing or charging.

Battery gas can explode and cause serious injury.

W-2066-0705

Figure 60-30-4

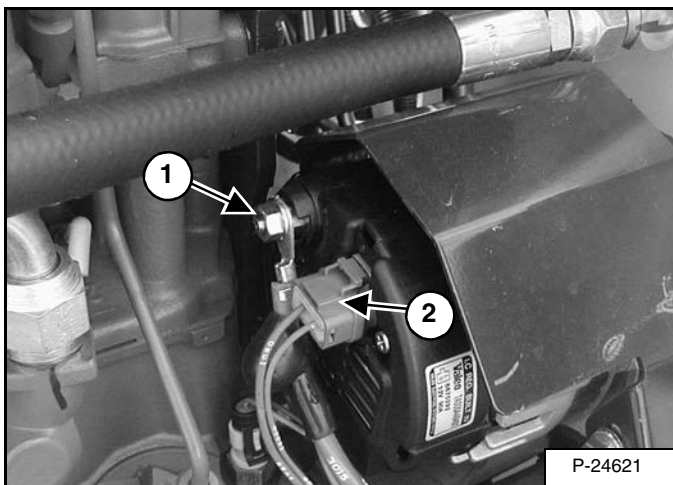

P-24621

IMPORTANT

Damage to the alternator can occur if:

- Engine is operated with battery cables disconnected.
- Battery cables are connected when using a fast charger or when welding on the loader. (Remove both cables from the battery.)
- Extra battery cables (booster cables) are connected wrong.

I-2023-1285

If the charging system malfunctions check the following:

1. Check the condition and tension of the alternator belt. (See Adjusting The Alternator Belt on Page 60-30-1.) If belt is worn or deteriorated replace.
2. Inspect the alternator wiring harness and connectors at alternator. Harness and connectors must be clean and tight.
3. Check the fuse for the alternator in the fuse panel. If fuse is burned, find the cause and repair / replace. If fuse is in doubt, remove it and check for continuity.
4. Check the electrolyte level in the battery. Add distilled water as needed. (Does not apply to maintenance free batteries.)
5. Verify the charge of the battery. Make sure battery is fully charged.
6. Disconnect the battery cables (negative first, then positive). Inspect the cable clamps and battery posts for corrosion. Remove acid or corrosion from the battery and cables with a sodium bicarbonate and water solution. Put grease on the cable ends and battery terminals to prevent corrosion. Reconnect the cable to the positive terminal.
7. With the key off, connect a test light between the negative battery post and the disconnected negative cable clamp.

A. If the test light does not light up, reattach the clamp and proceed to alternator voltage test. (See Below.)

B. If the test light lights up, there is a short (drain) in the electrical system of the loader. The short must be repaired before the charging system can be checked.

C. Disconnect the alternator B+ terminal (Item 1) [Figure 60-30-4] and L & S terminal connector (Item 2) [Figure 60-30-4] and if the test light goes out, the alternator is faulty. If the test light stays on, find the short in the system and repair it.

STARTER (NIPPONDENSO) (CONT'D)

Parts Identification

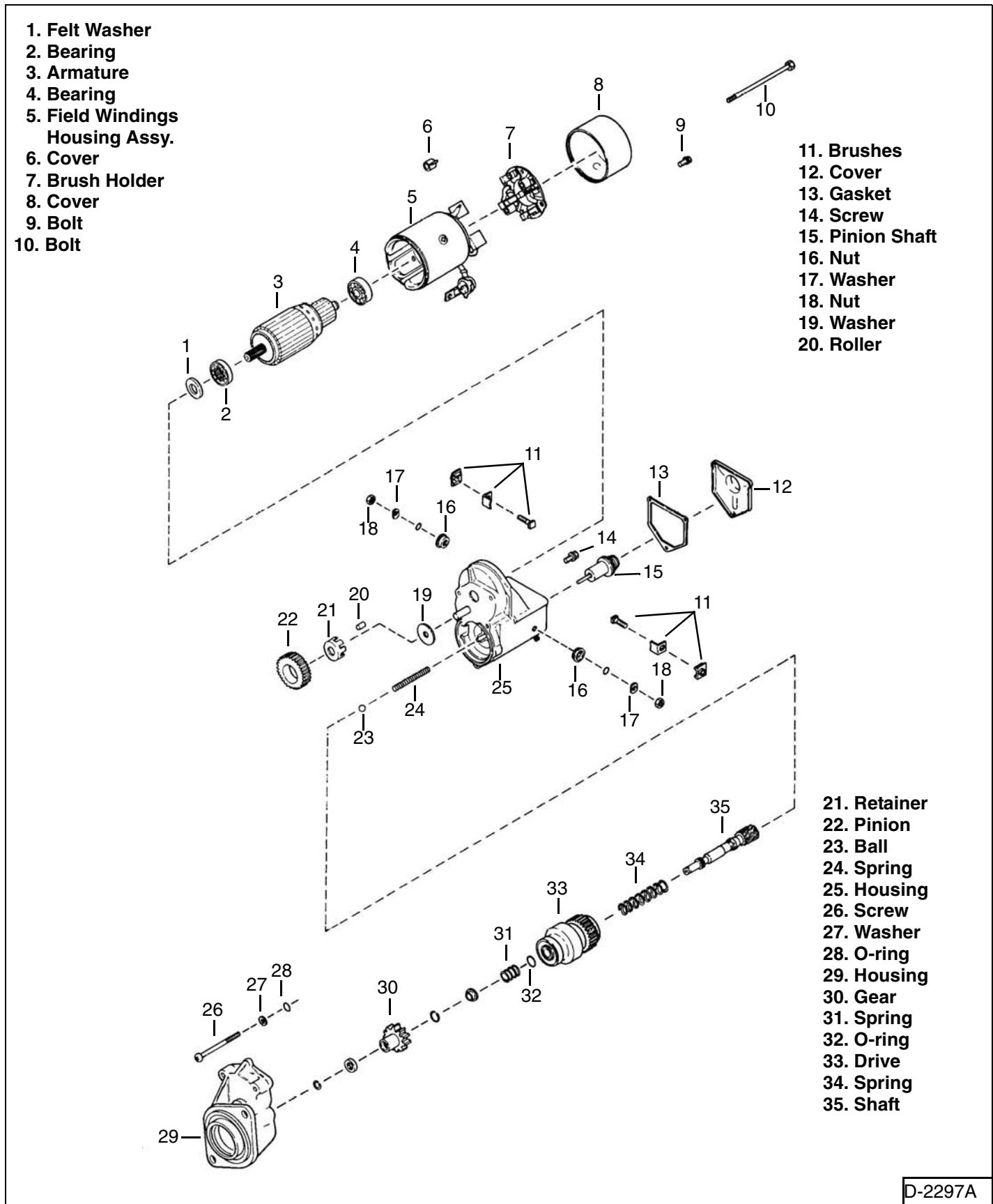



Bobcat®



Bobcat®

INSTRUMENT PANEL (CONT'D)

Standard Panel Removal And Installation (Right Side) (Cont'd)

Ignition Switch Removal And Installation Standard Panel (Cont'd)

Figure 60-50-10

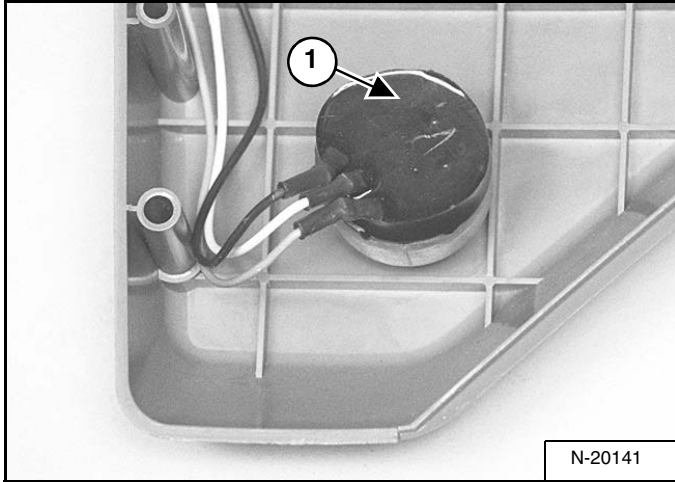

Remove the ignition switch (Item 1) [Figure 60-50-10] from the control panel.

Deluxe Panel Removal And Installation (Right Side)

Figure 60-50-11

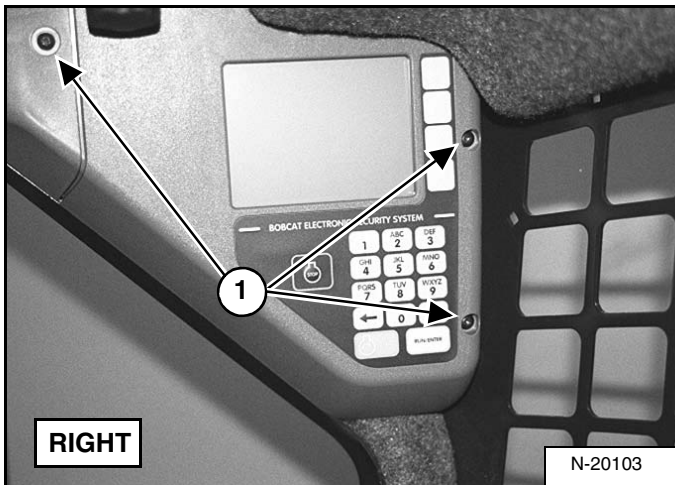

Remove the three mounting bolts (Item 1) [Figure 60-50-11].

Installation: Be careful to not overtighten the instrument panel mounting bolts to prevent stripping of the threaded holes in the panels.

Figure 60-50-12

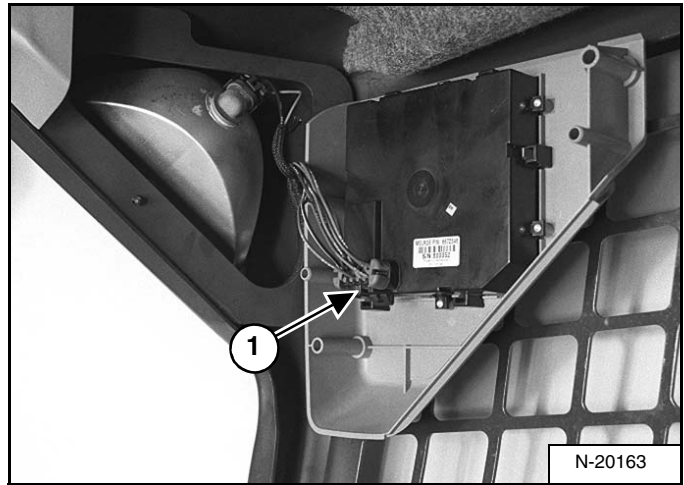

Pull the right instrument panel down and disconnect the wire harness connector (Item 1) [Figure 60-50-12] from the panel.

Remove the panel from the loader cab.

Figure 60-50-13

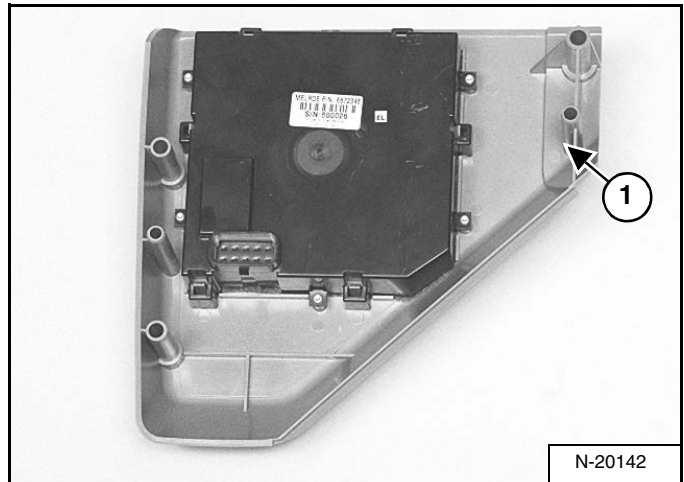

NOTE: The instrument panel (Item 1) [Figure 60-50-13] must be replaced as a complete unit.

BOBCAT CONTROLLER (CONT'D)

Removal And Installation

! WARNING

Never work on a machine with the lift arms up unless the lift arms are secured by an approved lift arm support device. Failure to use an approved lift arm support device can allow the lift arms or attachment to fall and cause injury or death.

W-2059-0598

Figure 60-70-1

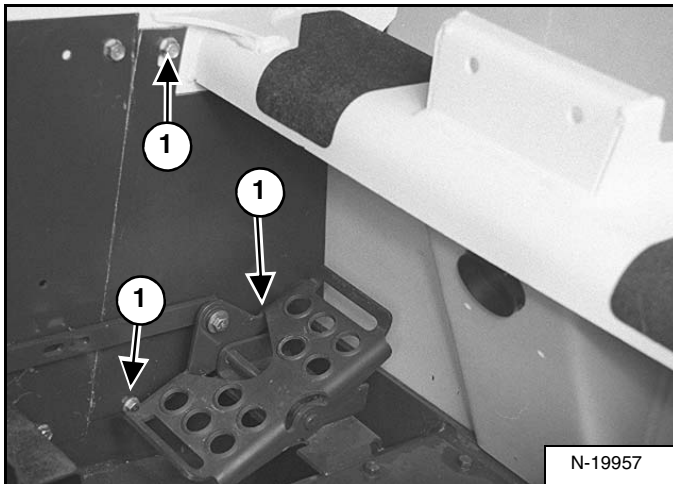

Raise the lift arms and install an approved lift arm support device. (See LIFT ARM SUPPORT DEVICE on Page 10-20-1.)

Stop the engine. Raise the seat bar.

Lift and block the rear of the loader. (See LIFTING AND BLOCKING THE LOADER on Page 10-10-1.)

Raise the operator cab. (See Raising The Operator Cab on Page 10-30-1.)

Remove the left front side panel mount bolts (Item 1)[Figure 60-70-1].

Remove the left front side panel.

Figure 60-70-2

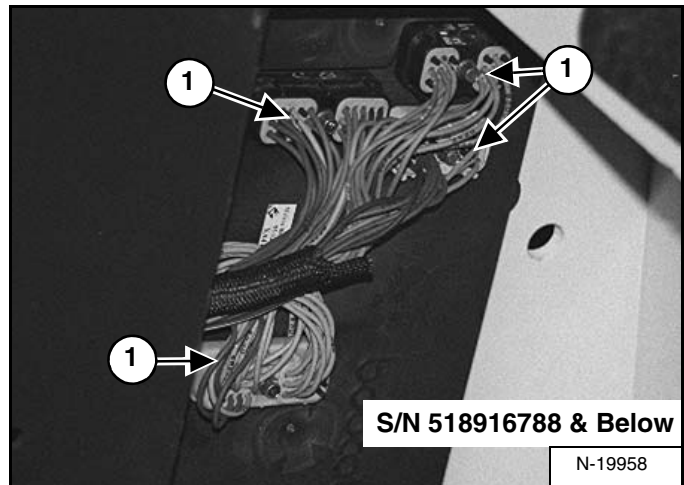

Loosen the harness connector mounting bolts (Item 1) [Figure 60-70-2] from the Bobcat controller.

Installation: Tighten the connector bolts to 30 - 35 in.-lb. (3,39 - 3,96 N•m) torque.

Unplug the individual harness connectors from the controller.

NOTE: The connectors are keyed and will only plug in one way.

Figure 60-70-3

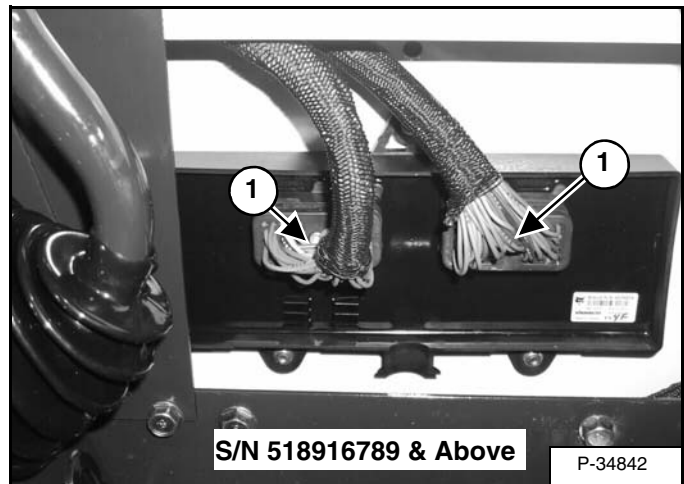

Loosen the harness connectors mounting bolts (Item 1) [Figure 60-70-3] from the Bobcat controller.

Remove the connectors.

NOTE: The connectors are keyed and will only plug in one way.

SEAT BAR SENSOR (CONT'D)

Test

Figure 60-100-1

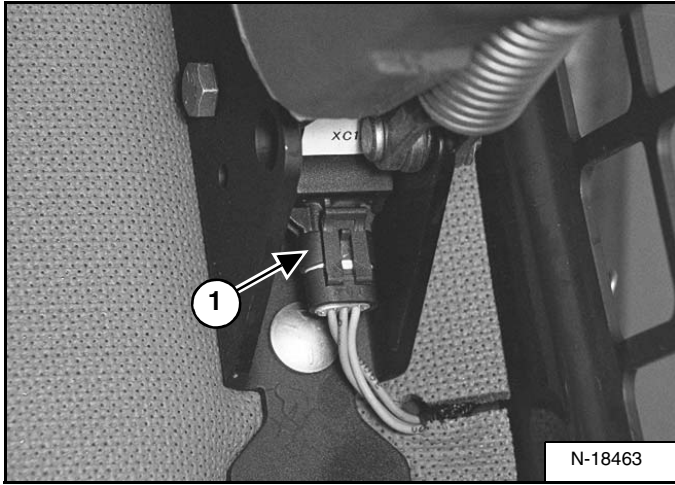

Use Sensor Tester (MEL1428) and seat bar sensor tester adapter (MEL1567) for the following procedure:

Connect the seat bar adapter sensor leads (MEL1567) to the sensor tester.

Disconnect the seat bar sensor connector (Item 1) [Figure 60-100-1].

Figure 60-100-2

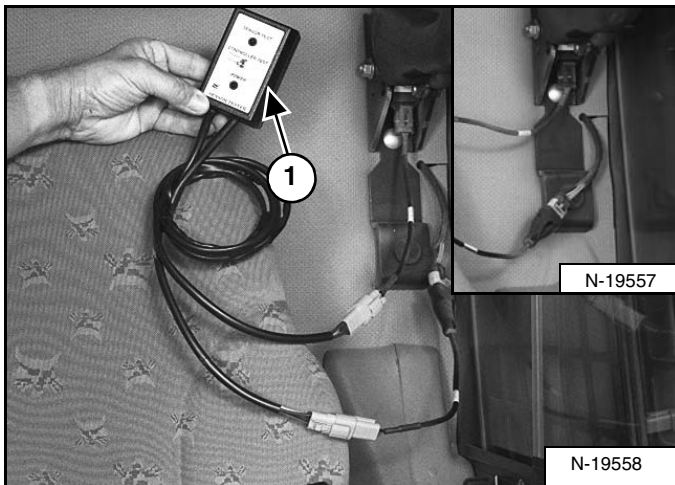

Connect the Sensor Tester (Item 1) [Figure 60-100-2] inline, to the seat bar sensor connectors. See inset [Figure 60-100-2].

Turn the key to the ON position. **DO NOT START THE ENGINE.**

The toggle switch (Item 2) [Figure 60-100-3] can be in either the **Absent** or **Present** position.

Figure 60-100-3

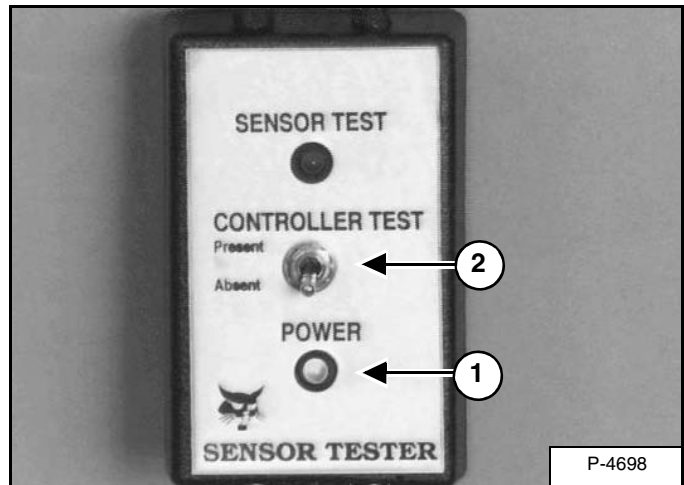

If there is no power light (Item 1) [Figure 60-100-3] on the sensor tester, check the tester or wiring harness.

Figure 60-100-4

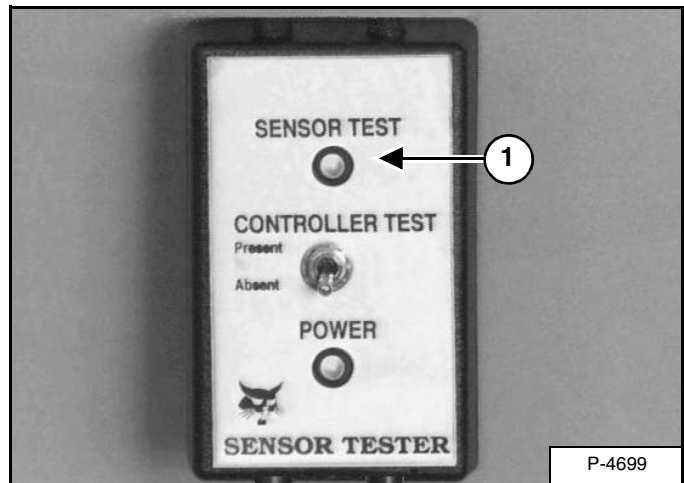

Lower the seat bar. The Sensor Test light (Item 1) [Figure 60-100-4] should illuminate.

Raise the seat bar. The Sensor Test light (Item 1) [Figure 60-100-4] should go off.

If the above test fails, there is a problem with the seat bar sensor.

Disconnect the Sensor Tester.

Replace the Seat Bar Sensor. (See Removal And Installation on Page 60-100-3.)

If the above test passes, run the seat bar sensor BICS circuit test. (See BICS™ Circuit Test on Page 60-100-4.)

ADVANCED CONTROL SYSTEM (ACS) ADVANCED HAND CONTROL (CONT'D)

Troubleshooting Guide

The Advanced Control System (ACS) has a built-in diagnostic function which uses an icon on the right instrument panel to indicate the condition of the ACS SYSTEM. The system also records the alarm condition as a service code.

The control module continually checks the system in the order listed. The checks start with the lift handle sensor and then the lift actuator. If no problems are present, it will then check the tilt handle sensor and the tilt actuator. The system will stop its check at the first problem and then illuminate the icon.

The system starts its diagnostics and calibration when the ignition key is turned ON.

The following list shows the probable causes when the icon is illuminated.

| Advanced Control System | General Warning | Fuel Level | System Voltage | Engine Oil Pressure | Engine Coolant Temperature | Air Filter |
|---|-----------------|------------|----------------|---------------------------|----------------------------|------------------|
| | | | | | | |
| | | | | | | |
| Attachment Control Device | Two Speed | Glow Plugs | Seatbelt | Hydraulic Charge Pressure | Hydraulic Oil Temperature | Hydraulic Filter |
| <p>Advanced Control System</p> <div style="display: flex; justify-content: space-between;"> <div style="width: 45%;"> <p> Errors - lights solid with 3 beeps</p> <p>32-04 - ACS in error</p> <p>32-23 - ACS not calibrated</p> <p>32-49 - Lift actuator short to ground</p> <p>32-50 - Tilt actuator short to ground</p> <p>32-51 - Lift actuator short to battery</p> <p>32-52 - Tilt actuator short to battery</p> <p>32-53 - Lift handle / pedal short to ground</p> <p>32-54 - Tilt handle / pedal short to ground</p> <p>32-55 - Lift handle / pedal short to battery</p> <p>32-56 - Tilt handle / pedal short to battery</p> <p>32-57 - Lift actuator reduced performance</p> </div> <div style="width: 45%;"> <p>32-58 - Tilt actuator reduced performance</p> <p>32-59 - Lift actuator wrong direction</p> <p>32-60 - Tilt actuator wrong direction</p> <p>32-61 - Handle lock short to ground</p> <p>32-62 - Handle lock short to battery</p> <p>32-63 - Pedal lock short to ground</p> <p>32-64 - Pedal lock short to battery</p> <p>32-65 - Sensor supply voltage out of range</p> <p>32-66 - Battery out of range</p> <p>32-67 - Switch moved while operating</p> </div> </div> | | | | | | |

To see what error occurred, check the service code on the left instrument panel. (See DIAGNOSTICS SERVICE CODES on Page 60-80-1.)



Bobcat®

ADVANCED CONTROL SYSTEM (ACS) SELECTABLE HAND / FOOT CONTROL (CONT'D)

Switch Handle Installation (Cont'd)

Figure 60-121-23

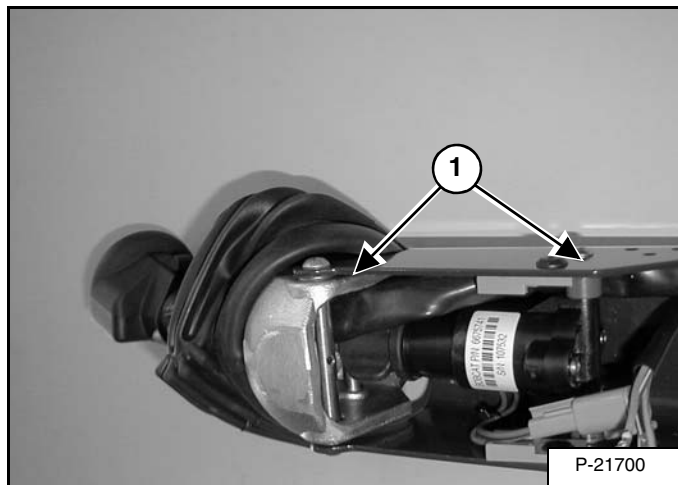

Install the new switch handle and wires from the top of the control lever.

Route wire (Item 1) [Figure 60-121-23] through the casting, along side the handle sensor and into the control lever tube.

NOTE: Do not pull the wire harness tight, allow a small amount of slack or slight bend at the handle pivot area. Verify the control handle returns to neutral position.

Figure 60-121-24

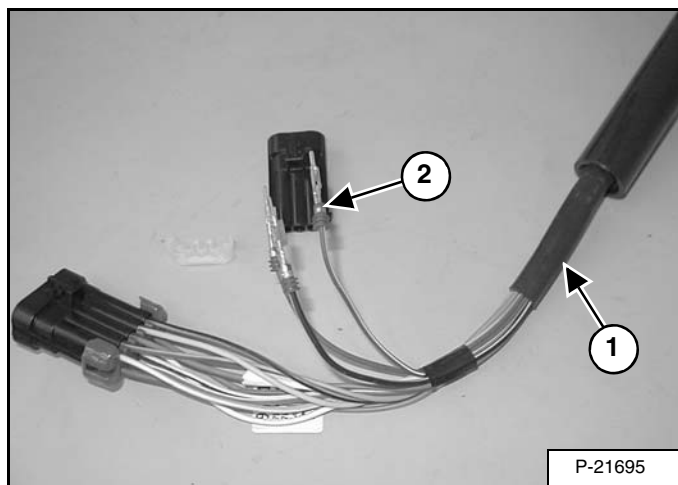

Remove tape from wires for installation and install the 6 in. of heat shrink tube (Item 1) [Figure 60-121-24] approximately 3 in. into the control lever. Apply heat to the exposed heat shrink tube.

Inspect the wire terminal tabs (Item 2) [Figure 60-121-24] and re-bend tabs if necessary.

Install the wires into the connectors as listed below:

Right Switch Handle

Ten-Pin Connector
A-Terminal - Orange
B-Terminal - White
C-Terminal - White/Black
D-Terminal - White/Red
E-Terminal - Dk. Green
F-Terminal - White/Lt. Green
G-Terminal - Yellow/Red
H-Terminal - Lt. Green
J-Terminal - Yellow
K-Terminal - Orange/Black

Three-Pin Connector
A-Terminal - Red/White
B-Terminal - Black/White
C-Terminal - Purple/White

Left Switch Handle

Ten-Pin Connector
A-Terminal - Orange
B-Terminal - Dk. Blue
C-Terminal - White
D-Terminal - Purple
E-Terminal - Yellow/Red
F-Terminal - Tan
G-Terminal - Pink
H-Terminal - Orange/Black
J-Terminal - Blank
K-Terminal - Blank

Three-Pin Connector
A-Terminal - Red/White
B-Terminal - Black/White
C-Terminal - Purple/White

Two-Pin Connector
A-Terminal - Black
B-Terminal - Red

Five-Pin Connector
A-Terminal - Dk. Green
B-Terminal - Brown
C-Terminal - Blank
D-Terminal - Yellow
E-Terminal - Blank

**ADVANCED CONTROL SYSTEM (ACS) SELECTABLE
HAND / FOOT CONTROL (CONT'D)**

Foot Lock Solenoid Connector (Cont'd)

Figure 60-121-56

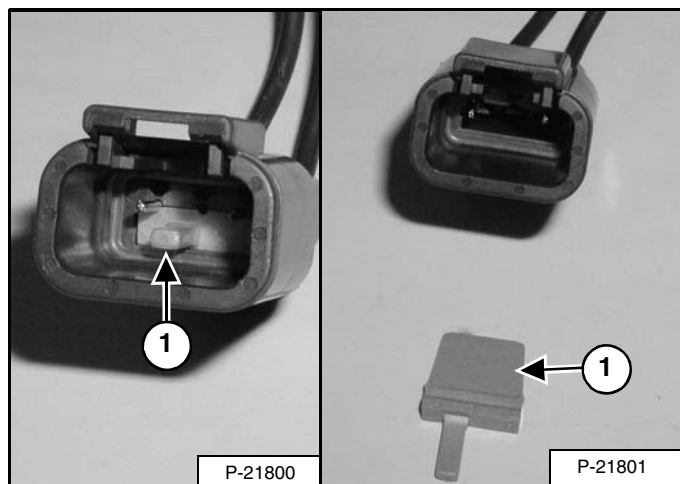

Remove the wedge (Item 1) [Figure 60-121-56] from the connector.

Figure 60-121-57

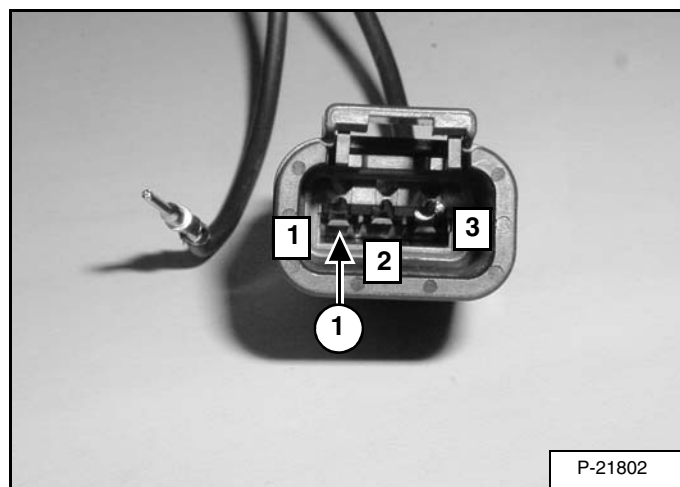

With a pointed tool, lift the tab (Item 1) [Figure 60-121-57] and pull the wire from the connector.

Installation: Install the wires into the connector as listed below [Figure 60-121-57]:

- 1 - Terminal - Black
- 2 - Terminal - Open
- 3 - Terminal - Black



Bobcat®

COOLING FAN (CONT'D)

Gearbox / Blower Housing Removal And Installation (Cont'd)

Figure 70-60-15

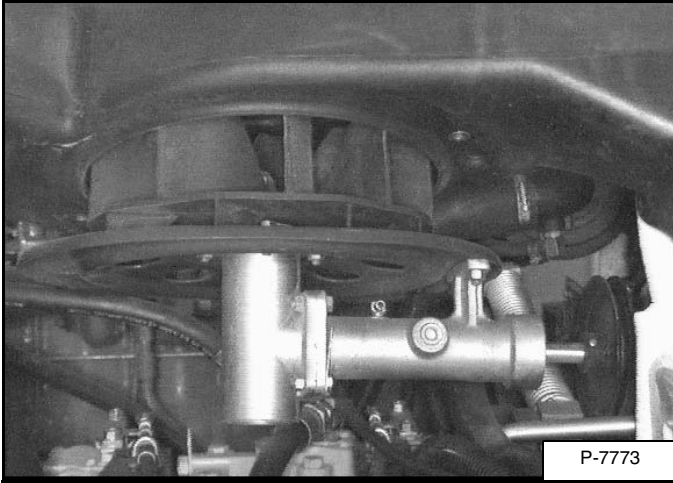

Slide the blower housing forward and remove the fan / fan gearbox assembly. Remove the blower housing [Figure 70-60-15].

Installation: Use R.T.V. sealant to re-seal the blower housing to the loader frame (Item 1) [Figure 70-60-13].

(See Gearbox Disassembly on page 70-60-7 for Disassembly of the Fan Gearbox.)

Figure 70-60-16

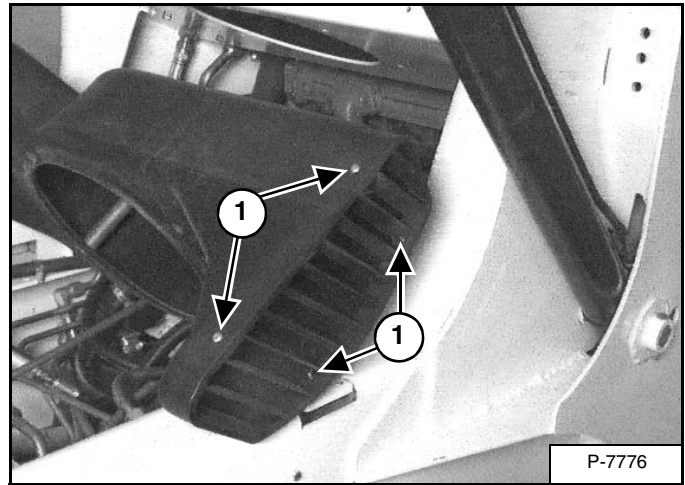

The blower housing must be moved away from the loader frame if the side grills need to be replaced [Figure 70-60-16].

To replace the side grill, remove the four mounting screws (Item 1) [Figure 70-60-16] from the blower housing.

Install the new grill and replace the screws.

COOLING FAN (CONT'D)

Gearbox Assembly (Cont'd)

Figure 70-60-46

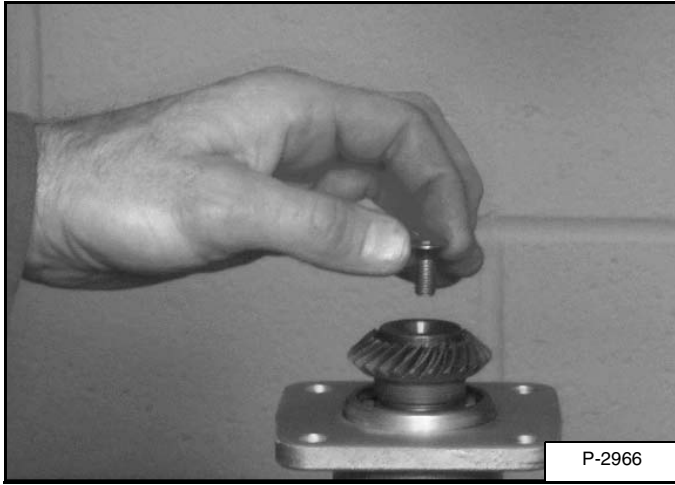

Install the washer [Figure 70-60-46].

Put liquid adhesive (Loctite® #242) on the screw threads. Install and tighten the screw [Figure 70-60-46].

Short Housing

Figure 70-60-47

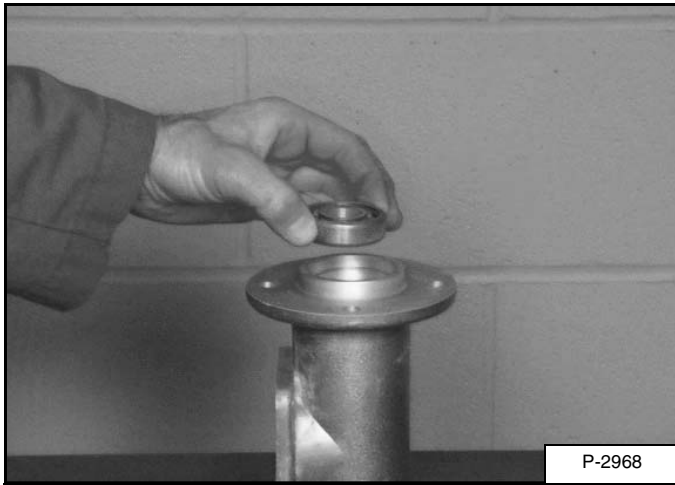

Install a bearing in the flanged end of the housing [Figure 70-60-47].

Figure 70-60-48

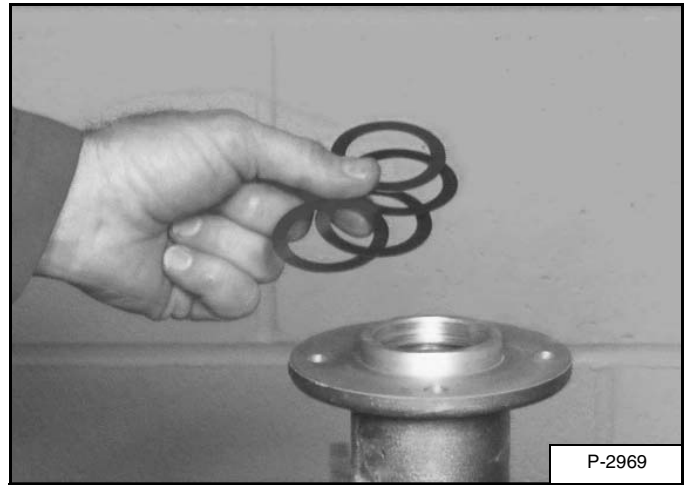

Install the large shims on the bearing (flanged end) [Figure 70-60-48].

Figure 70-60-49

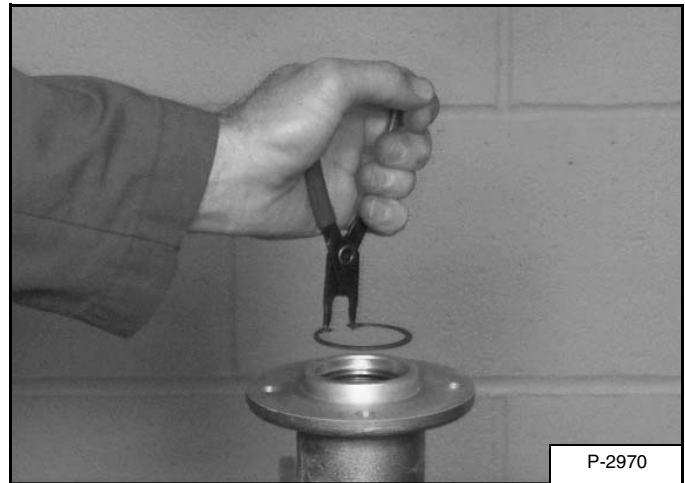

Install the large snap ring in the groove above the shims [Figure 70-60-49].

ENGINE COMPONENTS AND TESTS (CONT'D)

Fuel Shut-Off Solenoid Removal and Installation

Figure 70-70-11

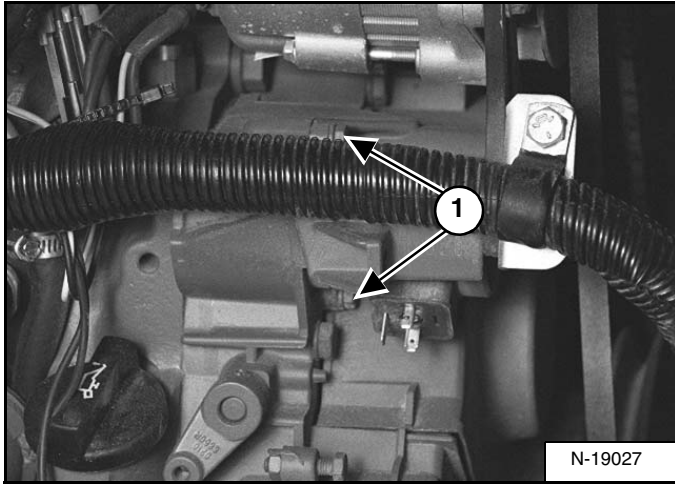

Remove the two mounting bolts (Item 1) [Figure 70-70-11].

Installation: Tighten the mounting bolts to 10 - 12 ft.-lb. (13,5 - 16,3 N•m) torque.

Remove the fuel shut-off solenoid from the engine.

Figure 70-70-12

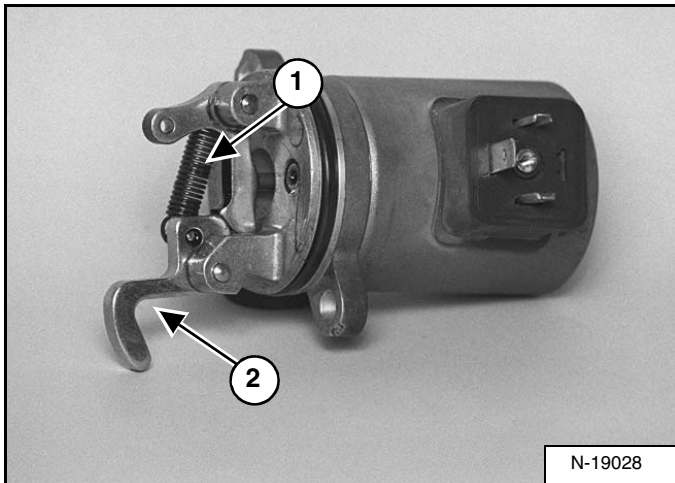

Check the solenoid spring (Item 1) [Figure 70-70-12] and linkage (Item 2) [Figure 70-70-12]. Replace the solenoid as needed.

NOTE: When installing the fuel shut-off solenoid in the engine the linkage (Item 2) [Figure 70-70-12] must engage the fuel control rack.

Fuel Injection Pump Removal

The injection pump(s) contain parts which have a very close tolerance and its operation has a direct effect on the performance of the engine.

IMPORTANT

Do not attempt to maintain or adjust unless you are trained and have the correct equipment.

I-2028-0289

Figure 70-70-13

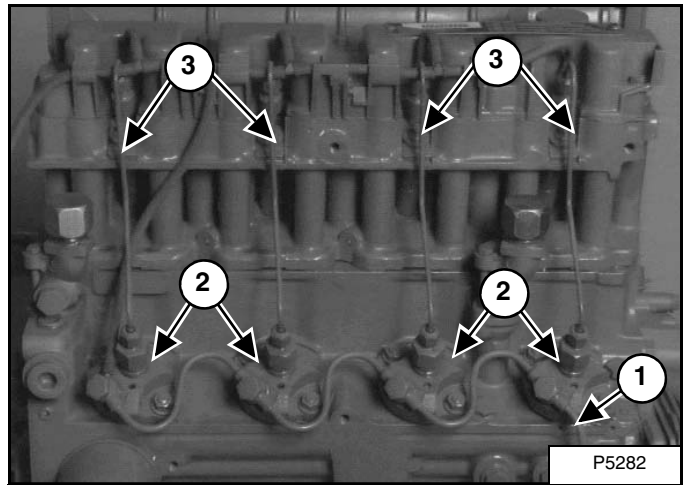

Remove the fuel tubeline (Item 1) [Figure 70-70-13] to the fuel injection pumps (Item 2) [Figure 70-70-13].

Disconnect the respective high pressure fuel line (Item 3) [Figure 70-70-13] from the injection pump to be removed and fuel injector.

ENGINE COMPONENTS AND TESTS (CONT'D)

Timing Belt Inspection

Figure 70-70-45

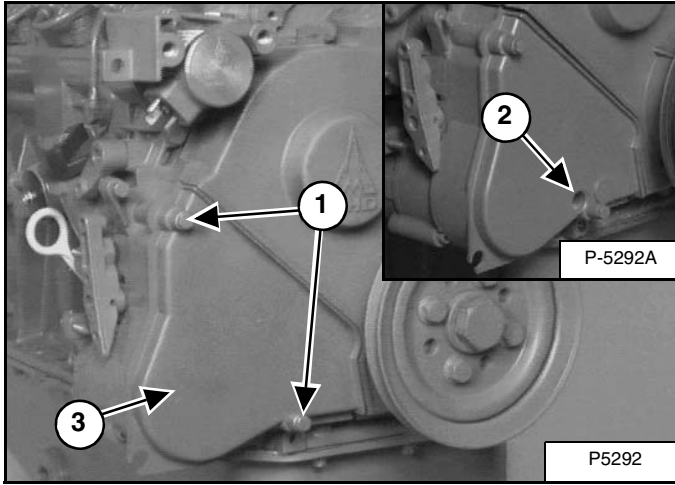

NOTE: The timing belt is maintenance free. Timing belts that are in operation do not need to be re-tensioned. The timing belt, belt tensioner and mount must be replaced every 3000 operating hours or every 5 years. A repair kit is available.

NOTE: If the timing belt has to be removed before 200 hours of engine operation, the timing belt can be re-used and re-tensioned according to the procedure listed.

To do the following procedure you need the following tool:

MEL1552 - Torx Bit

Remove the bolts (Item 1) [Figure 70-70-45] from the timing belt inspection cover.

Remove the torx bolt (Item 2) [Figure 70-70-45].

Remove the cover (Item 3) [Figure 70-70-45].

Figure 70-70-46

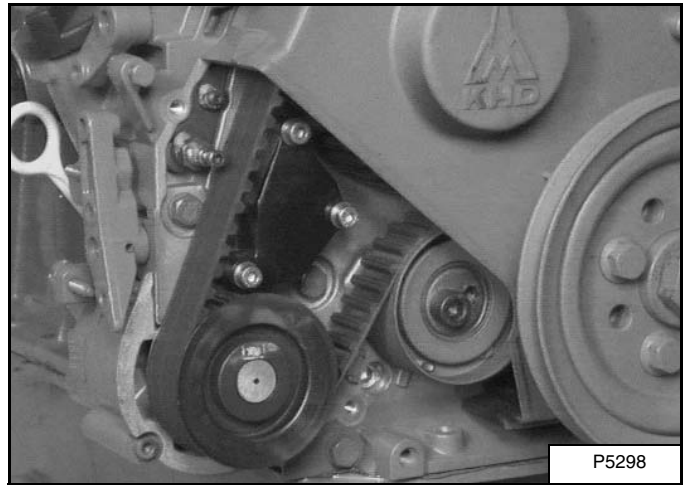

Check the timing belt, sprockets and tensioner for wear, cracks or damage [Figure 70-70-46].

Check the timing belt in detail for the following conditions, replace as needed.

1. Oil deposits
2. Hardened back rubber surfaces
3. Cracked
4. Badly worn teeth
5. Missing tooth
6. Side of belt badly worn
7. Side of belt cracked

Timing Belt Removal

Remove the bolts (Item 1) [Figure 70-70-45] from the timing belt inspection cover.

Remove the torx bolt (Item 2) [Figure 70-70-45].

Remove the cover (Item 3) [Figure 70-70-45].

ENGINE COMPONENTS AND TESTS (CONT'D)

Valve Clearance Adjustment

Figure 70-70-81

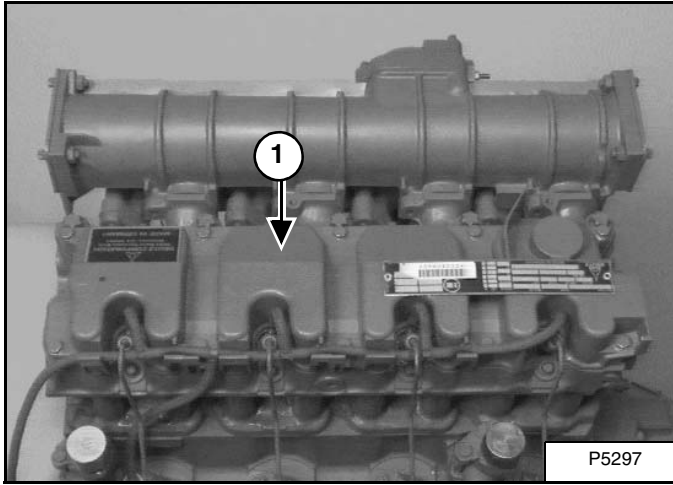

Make the valve clearance adjustment with engine stopped and cold.

Remove the valve cover (Item 1) [Figure 70-70-81].

When installing the valve cover bolts, tighten them to 75 in.-lb. (8,5 N•m) torque.

Figure 70-70-82

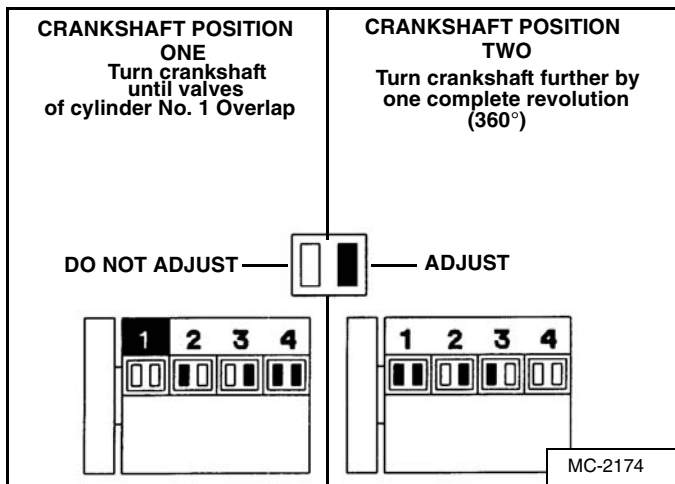

Use the following sequence as shown in figure [Figure 70-70-82] to set the valve clearance.

Turn the crankshaft until the valves of cylinder No. 1 over-lap [Figure 70-70-82].

Turn the crankshaft by one complete revolution (360°) and set the other valves.

Figure 70-70-83

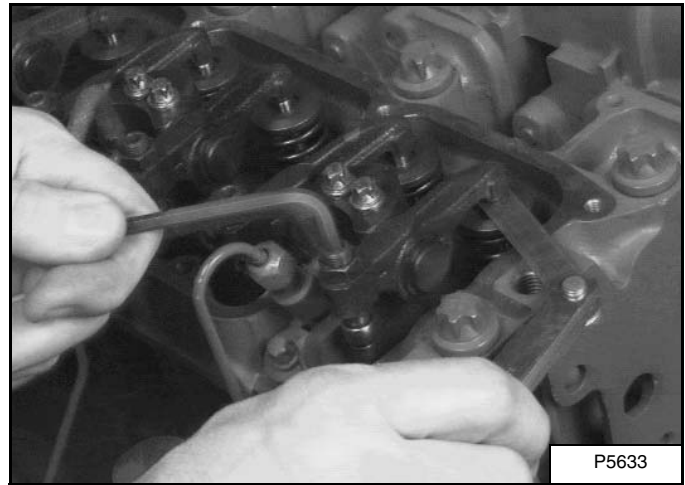

Loosen the locknut and turn the set screw until the clearance is correct.

Intake - 0.012 in. (0,3 mm)

Exhaust - 0.020 in. (0,5 mm)

Tighten the locknut to 13 - 16 ft.-lb. (18 - 22 N•m) torque.

ENGINE AND ENGINE MOUNTS (CONT'D)

Removal And Installation (Cont'd)

Figure 70-80-13

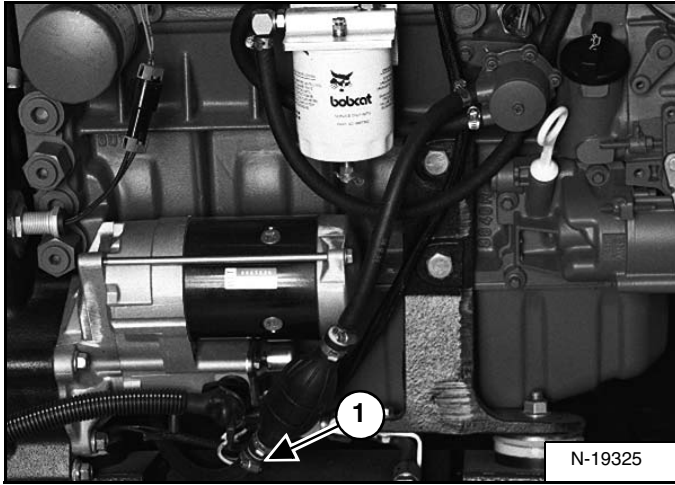

Disconnect and plug the fuel supply hose (Item 1) [Figure 70-80-13].

Figure 70-80-14

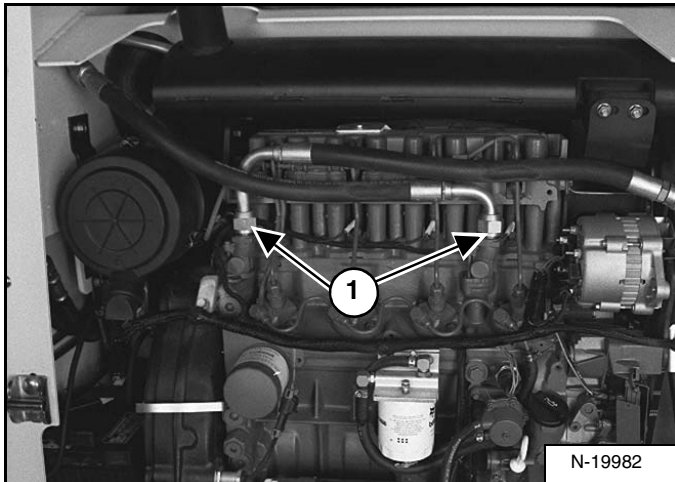

Disconnect and cap the engine oil to cooler hoses (Item 1) [Figure 70-80-14].

Remove the engine air cleaner. (See AIR CLEANER on Page 70-40-1.)

Remove the engine muffler. (See MUFFLER on Page 70-30-1.)

Figure 70-80-15

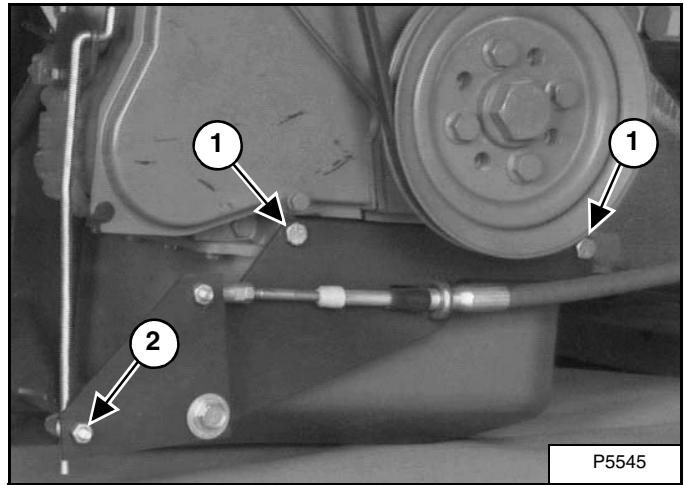

At the right side of the engine, remove the two throttle bracket mount bolts (Item 1) [Figure 70-80-15].

Disconnect the throttle rod connector (Item 2) [Figure 70-80-15].

Figure 70-80-16

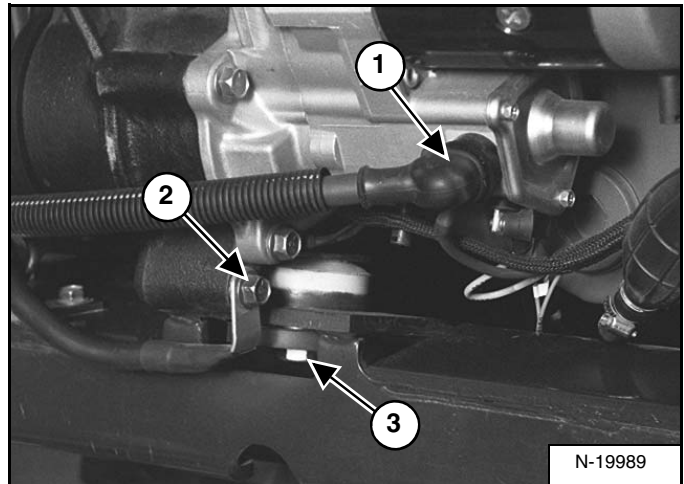

Disconnect the positive battery cable (Item 1) [Figure 70-80-16] from the starter.

Disconnect the negative battery cable (Item 2) [Figure 70-80-16] from the starter.

Remove the left rear engine mounting bolt (Item 3) [Figure 70-80-16] and nut.

Installation: Tighten the bolt and nut to 61 - 69 ft.-lb. (83 - 94 N•m) torque.

RECONDITIONING THE ENGINE (CONT'D)

Disassembly

Figure 70-100-1

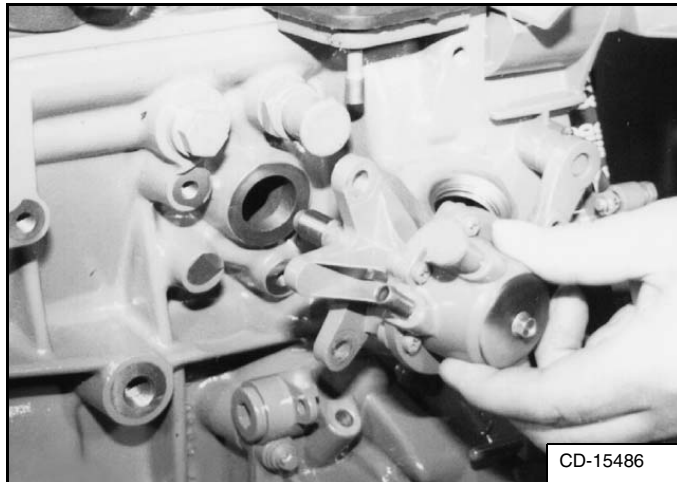

Remove the starter. (See Disassembly And Assembly on Page 60-40-3.)

Remove the alternator. (See Removal And Installation on Page 60-30-5.)

Drain the oil from the engine oil pan.

Remove the turbocharger. (See Turbo Charger Removal and Installation on Page 70-100-57.)

Remove the exhaust manifold.

Remove the intake manifold.

Remove the fuel injection pumps. (See Fuel Injection Pump Removal on Page 70-70-4.)

Remove the fuel injectors. (See Fuel Injector Removal and Installation on Page 70-70-9.)

Remove the oil filter.

Remove the fuel filter & fuel lift pump [Figure 70-100-1].

Remove the valve cover.

Figure 70-100-2

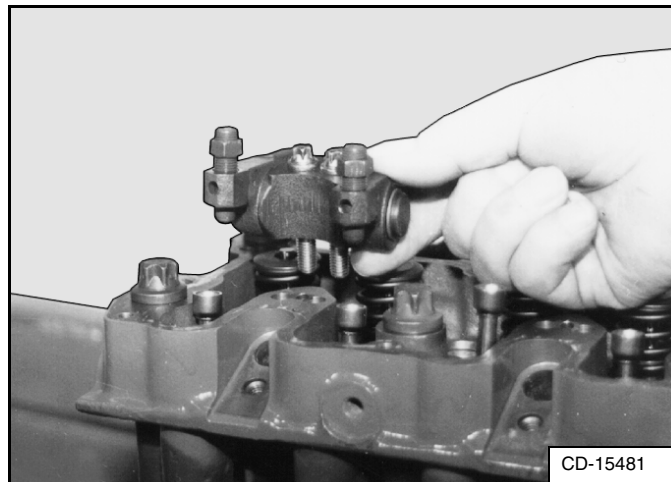

Remove the rocker arms and brackets [Figure 70-100-2].

Figure 70-100-3

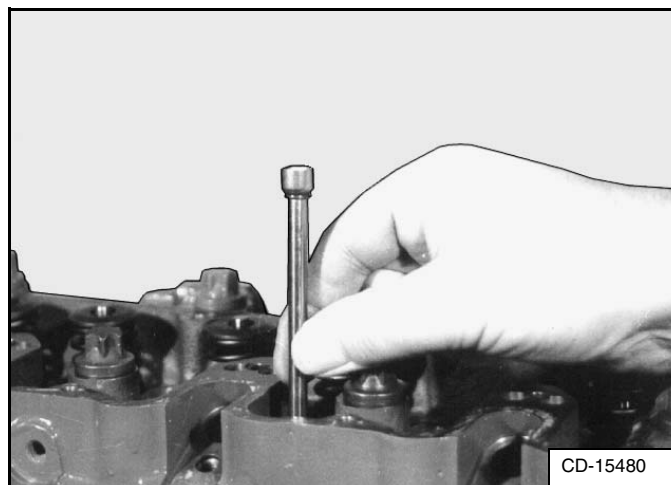

Remove the push rods [Figure 70-100-3].

RECONDITIONING THE ENGINE (CONT'D)

Assembly (Cont'd)

Figure 70-100-38

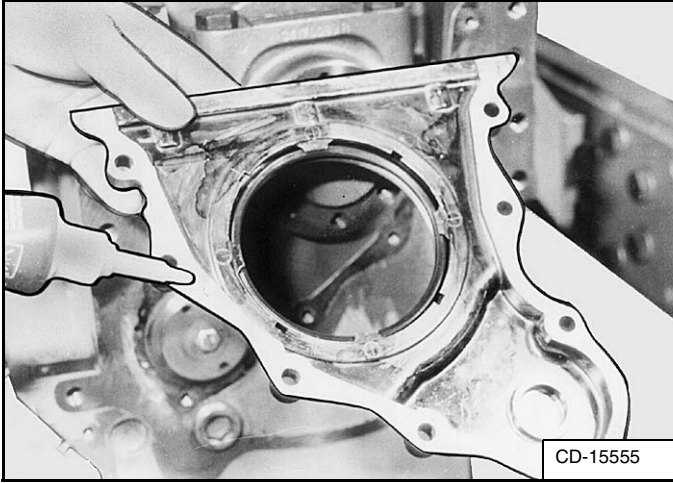

Put sealing compound on the rear cover [Figure 70-100-38].

Figure 70-100-39

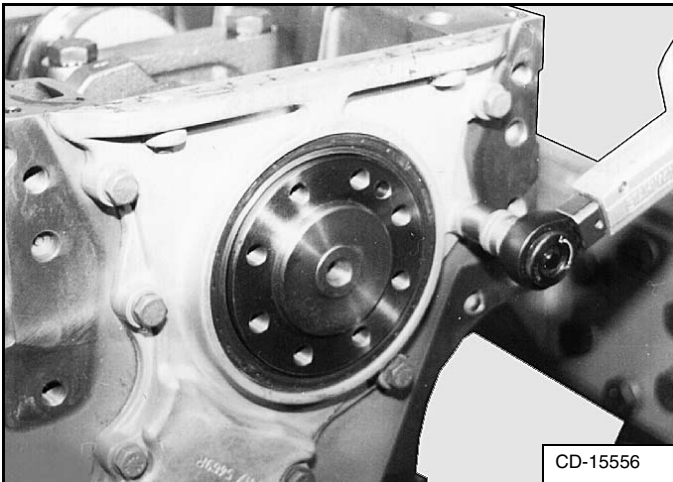

Install the rear cover complete with a new rear seal [Figure 70-100-39].

NOTE: Make sure the rear cover oil pan surface aligns with the engine block surface.

Tighten the bolts to 15 ft.-lb. (21 N•m) torque [Figure 70-100-39].

Figure 70-100-40



Measure the distance between the top edge of the crankpin (TDC) and cylinder head sealing surface at every cylinder [Figure 70-100-40].

Figure 70-100-41

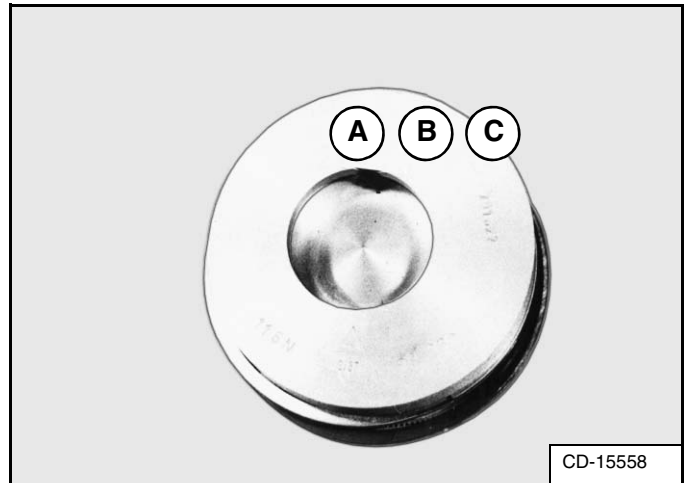

Compare actual dimension with the dimension listed [Figure 70-100-41]:

| Specifications: | |
|-----------------|--|
| Piston Class A | 7.732 - 7.736 in. (196,39 - 196,49mm) |

NOTE: If the crankshaft is undersize, 0.005 in. (0,125 mm) must be added to the dimension listed.

RECONDITIONING THE ENGINE (CONT'D)

Cylinder, Checking

Figure 70-100-77

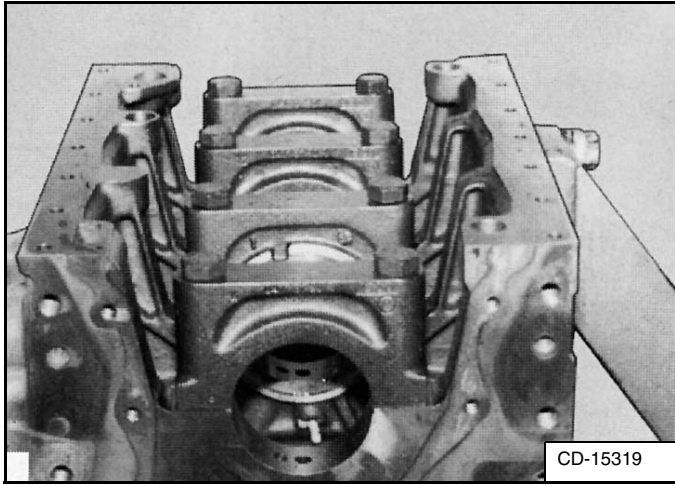

Clean the engine block and inspect for damage.

Install the main bearing caps [Figure 70-100-77].

Tighten the main bearing cap bolts as follows:

| | |
|-----------------|---------------------|
| Initial Torque | 37 ft.-lb. (50 N•m) |
| 1st Stage Angle | 60° |
| 2nd Stage Angle | 45° |

Figure 70-100-78

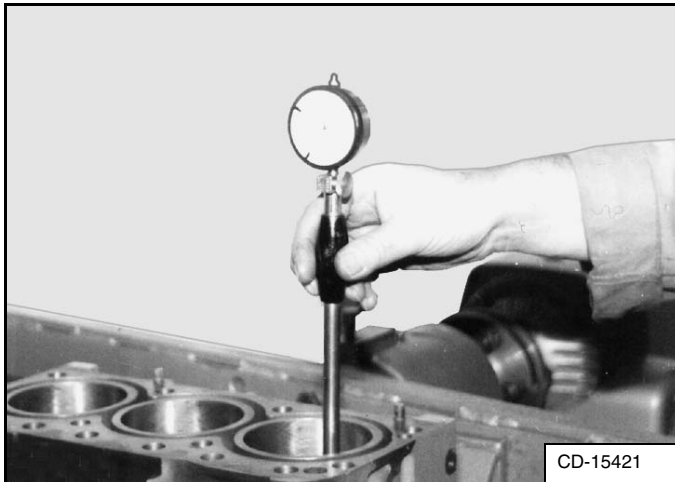

Using a dial indicator gauge check the cylinders [Figure 70-100-78].

Figure 70-100-79

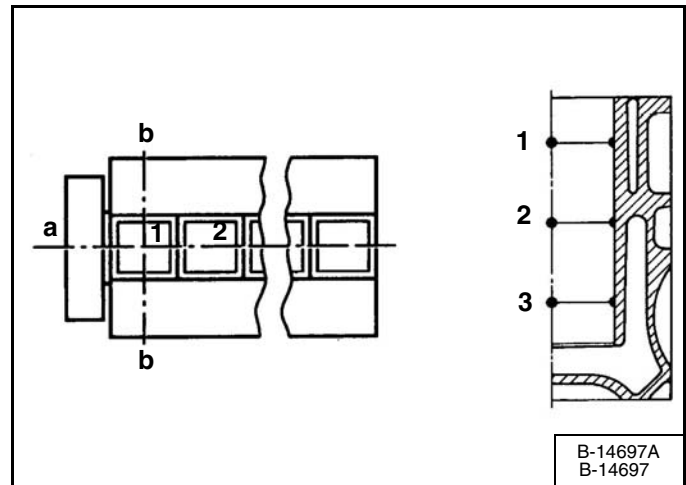

Check the cylinders with engine block longitudinal (a) and transverse (b) axis and in three planes [Figure 70-100-79].

| Specification | |
|---------------|-------------------------------------|
| Cylinder Bore | 3.58 + 0.0008 in. (91 + 0,02 mm) |
| Wear Limit | 3.59 in. (91,1 mm) |

RECONDITIONING THE ENGINE (CONT'D)

Crankshaft, Checking (Cont'd)

Figure 70-100-115

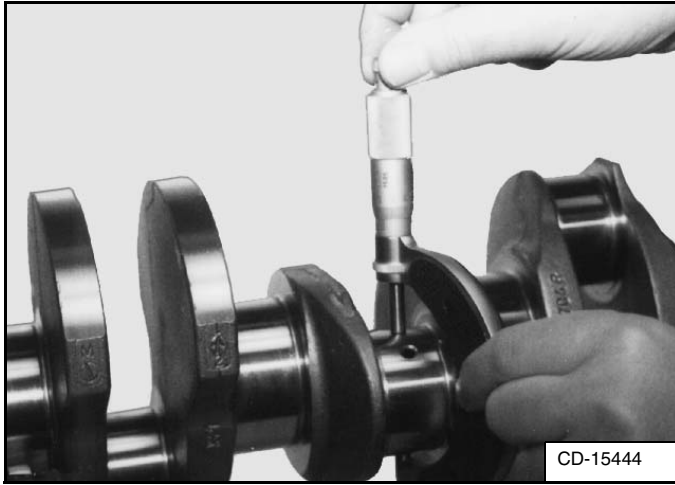

| Specifications: | |
|-----------------|-----------------------------------|
| Journal Width | 1.378 + 0.0016 in. (35+0.04mm) |
| Each Oversize | 0.016 in. (0,4 mm) |
| Oversize Limit | 1.395 in. (35,44 mm) |

Check the connecting rod journals [Figure 70-100-115].

| | |
|------------------------|--|
| Pin Dia. | 2.16 (55 -0.01 mm) -0.03 -0.0004 -0.0012 in. |
| Undersize Limit | 2.146 -0.0004 -0.0012 in. (54,5 -0.01 mm) -0.03 |
| Wear Limit Pin Oval | 0.0004in. (0,01 mm) |

Figure 70-100-116

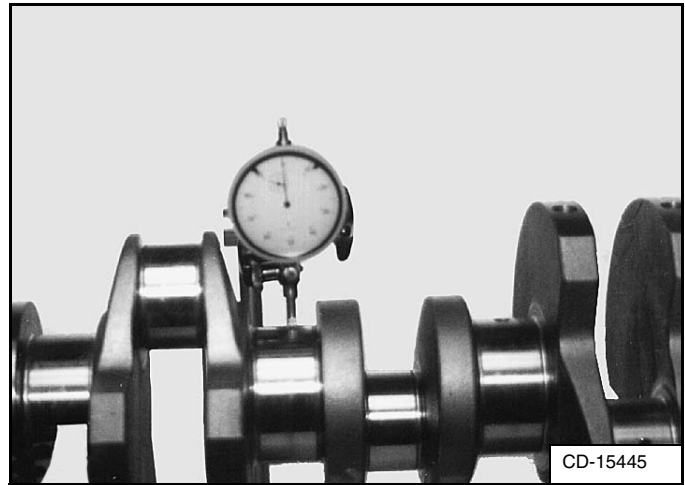

Use a dial indicator and check crankshaft for out of roundness [Figure 70-100-116].

| Specifications: | |
|----------------------|---------------------|
| Out of Roundness Max | 0.002 in. (0,05 mm) |

Figure 70-100-117

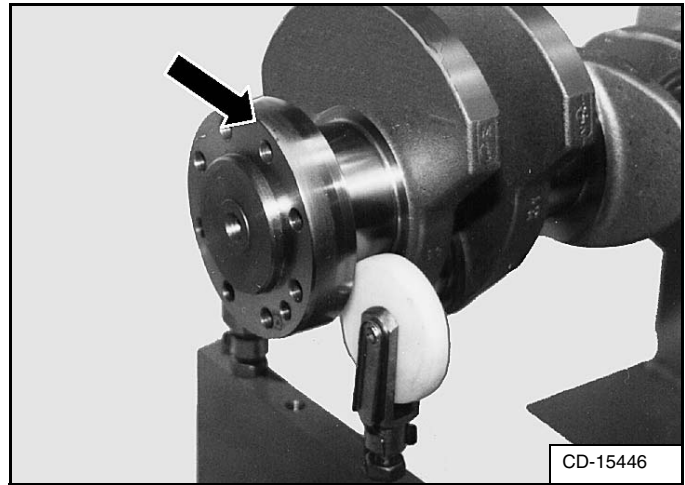

Check the surface of the crankshaft seal area [Figure 70-100-117].

Recondition the crankshaft as needed.

RECONDITIONING THE ENGINE (CONT'D)

Cylinder Head Assembly (Cont'd)

Figure 70-100-151

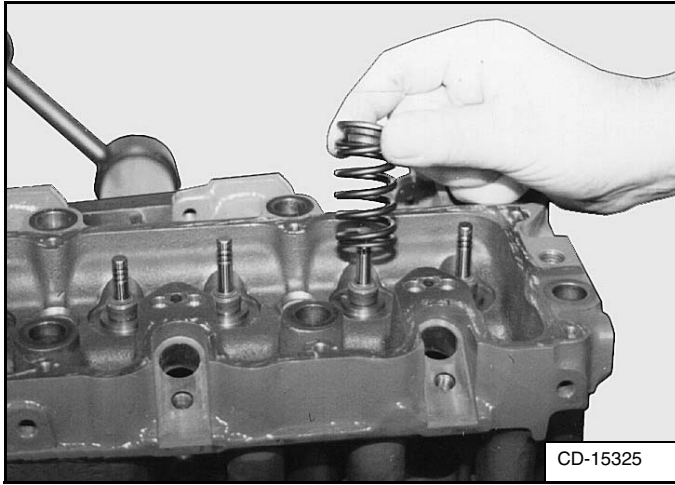

Install the valve spring and cap [Figure 70-100-151].

Figure 70-100-152

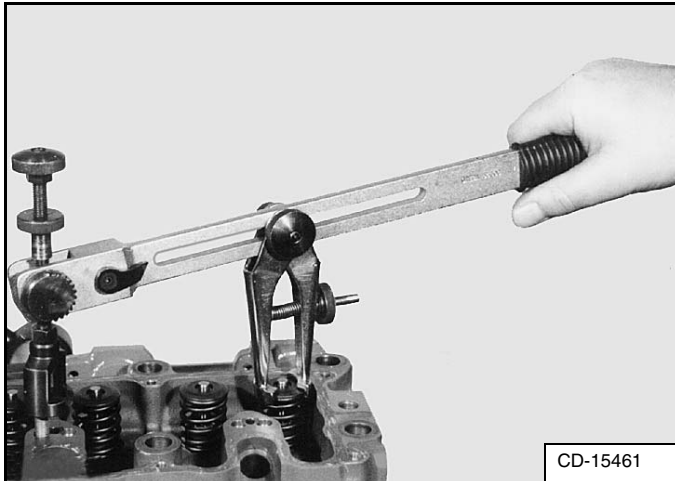

Use the valve spring tool, install the valve spring lock [Figure 70-100-152].

Repeat the above procedure to install all the valves.

Rocker Arm and Bracket, Checking

Figure 70-100-153

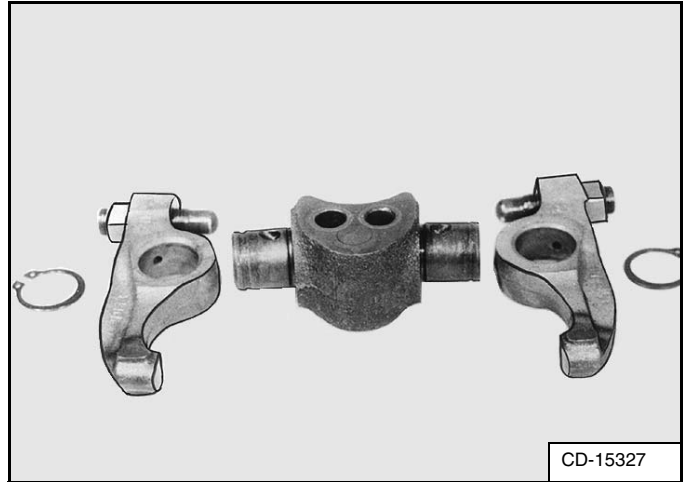

Disassemble the rocker arms from the bracket [Figure 70-100-153].

Figure 70-100-154

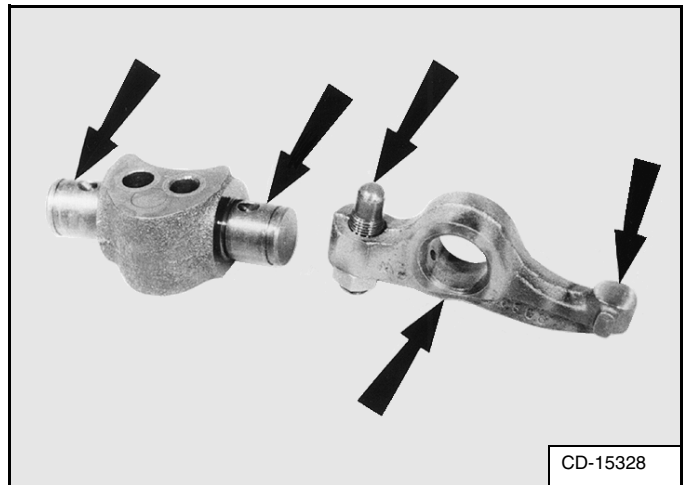

Check for wear at the following locations and replace as needed [Figure 70-100-154]:

- Journals
- Adjusting Bolt
- Rocker Arm Contact Face
- Bore

RECONDITIONING THE ENGINE (CONT'D)

Front Cover Assembly (Cont'd)

Figure 70-100-193

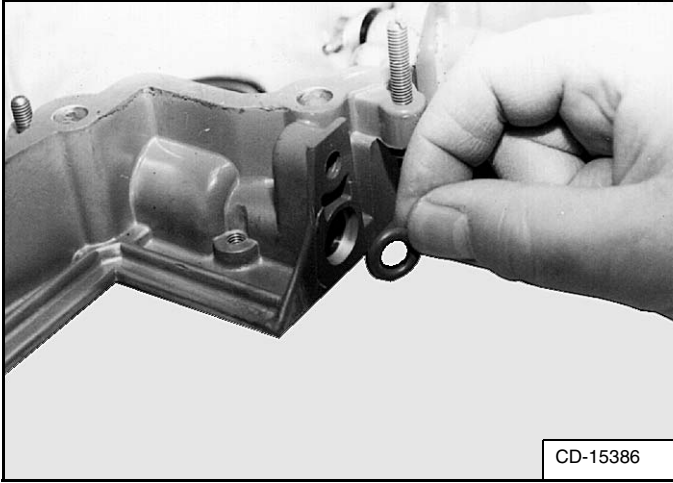

Put grease on the O-ring and install in the front cover [Figure 70-100-193].

Figure 70-100-194

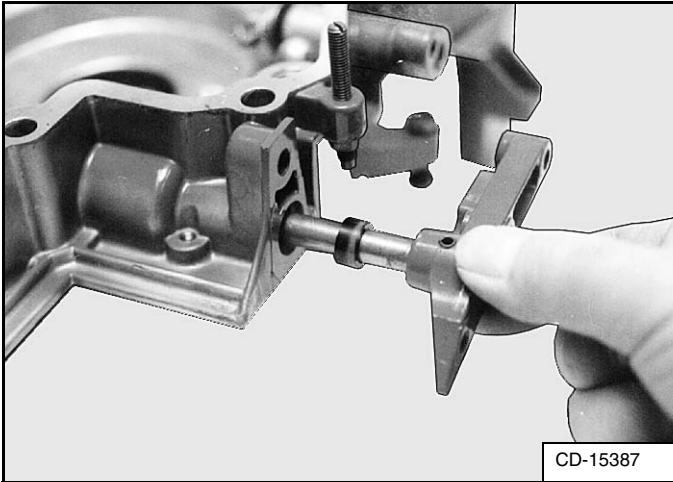

Install the spacer bushing on the speed control lever [Figure 70-100-194].

Install the speed control lever into the front cover [Figure 70-100-194].

Figure 70-100-195

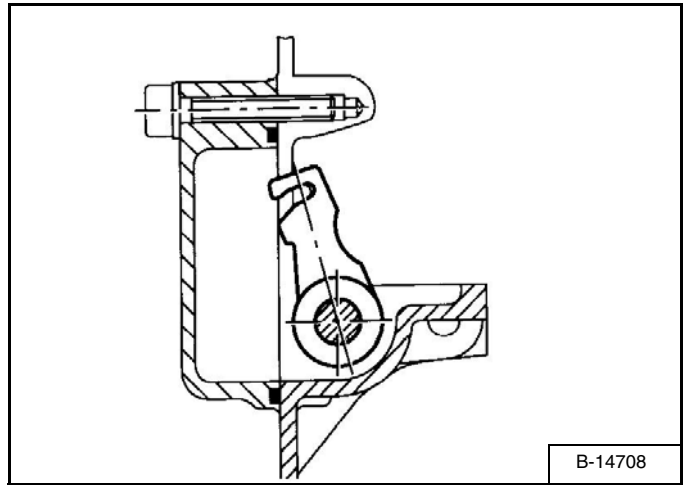

When installing the speed control lever, make sure it is installed in the correct direction [Figure 70-100-195].

Figure 70-100-196

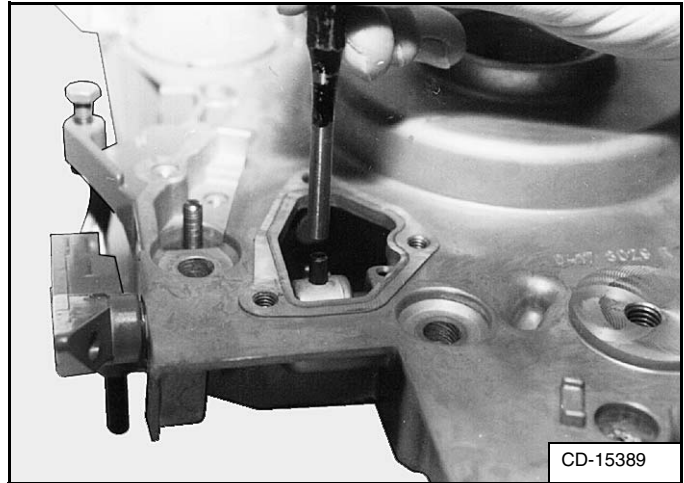

Install the dowel pin into the speed control lever [Figure 70-100-196].

HEATING, VENTILATION, AIR CONDITIONING (CONT'D)

| | |
|--|----------|
| HEATER / AC FAN | 80-210-1 |
| Disassembly And Assembly | 80-210-1 |
| Removal And Installation | 80-210-1 |
| Wire Connector Removal and Installation | 80-210-3 |
| HEATER VALVE | 80-220-1 |
| Disassembly And Assembly | 80-220-2 |
| Removal and Installation | 80-220-1 |
| PRESSURE RELIEF VALVE | 80-140-1 |
| Removal And Installation | 80-140-1 |
| PRESSURE SWITCH | 80-150-1 |
| Removal And Installation | 80-150-1 |
| RECEIVER / DRIER | 80-130-1 |
| Removal And Installation | 80-130-1 |
| REGULAR MAINTENANCE | 80-40-1 |
| Cleaning The Condenser | 80-40-2 |
| Compressor Drive Belt Inspection | 80-40-2 |
| Filter Elements Removal And Installation | 80-40-1 |
| SAFETY | 80-30-1 |
| Safety Equipment | 80-30-1 |
| SYSTEM CHARGING AND RECLAMATION | 80-100-1 |
| Charging Procedure | 80-100-4 |
| Charging Procedure With A Manifold Gauge Set | 80-100-3 |
| Reclamation Procedure | 80-100-1 |
| SYSTEM TROUBLESHOOTING CHART | 80-70-1 |
| Gauge Pressure Related Troubleshooting | 80-70-2 |
| TEMPERATURE / PRESSURE | 80-80-1 |
| Chart | 80-80-1 |
| THERMOSTAT | 80-170-1 |
| Removal And Installation | 80-170-1 |



Bobcat®

BASIC TROUBLESHOOTING (CONT'D)

Checking The Electrical System (Cont'd)

Figure 80-50-19

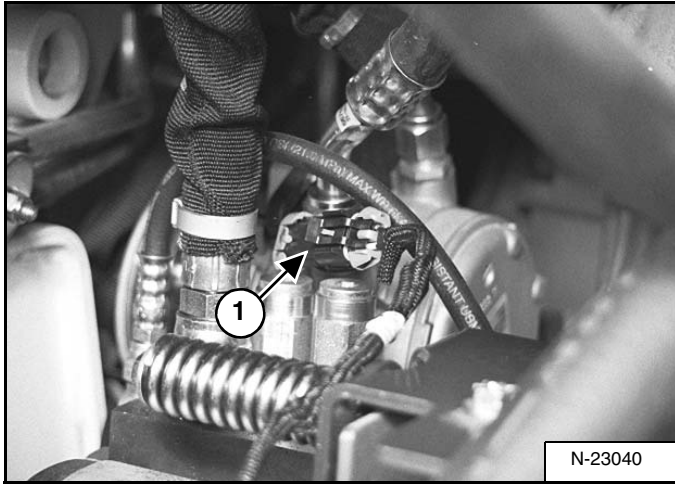

Raise the lift arms and install an approved lift arm support device. (See LIFT ARM SUPPORT DEVICE on Page 10-20-1.)

Raise the operator cab. (See Raising The Operator Cab on Page 10-30-1.)

Disconnect the loader harness (Item 1) [Figure 80-50-19] from the compressor clutch wire.

Figure 80-50-20

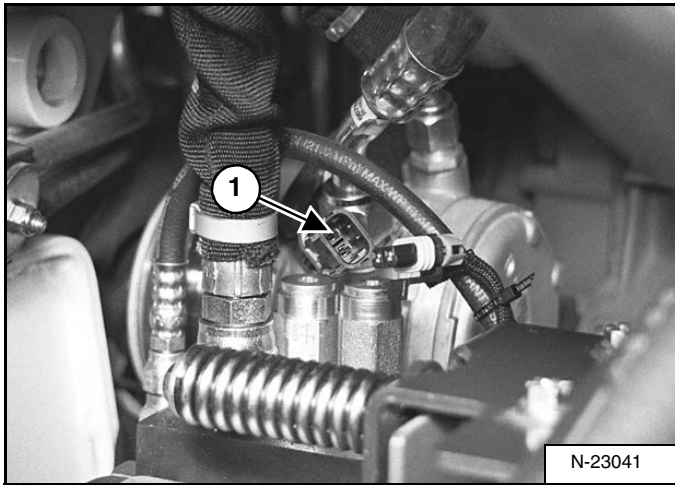

With a multimeter, check the resistance to the compressor clutch (Item 1) [Figure 80-50-20].

If there is no resistance value, replace the compressor clutch. (See Compressor Clutch Disassembly on Page 10-110-2.)

Figure 80-50-21

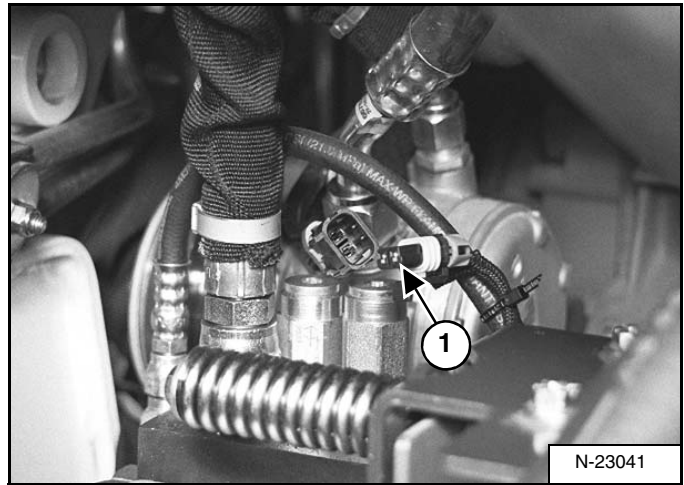

With a multimeter, check the voltage to the compressor clutch at the loader harness (Item 1) [Figure 80-50-21].

The voltage reading should be around 12 volts.

If there is no power at the clutch, check the wiring harness for broken wires.

If there is power at the clutch, reconnect the wiring harness to the compressor clutch.

Figure 80-50-22

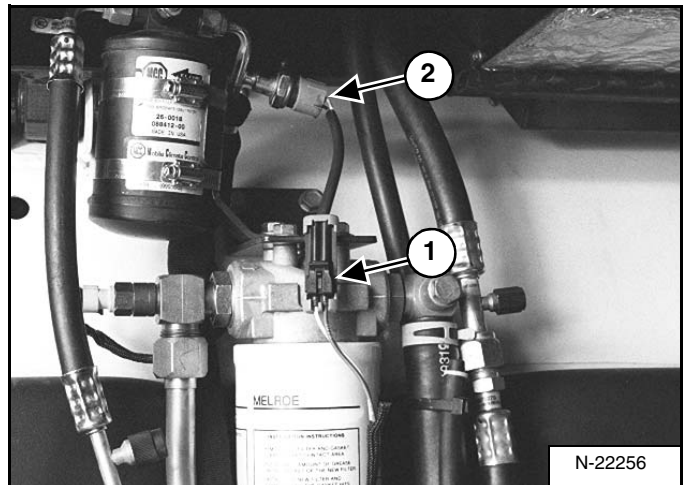

Disconnect the loader harness (Item 1) [Figure 80-50-22] from the pressure switch (Item 2) [Figure 80-50-22].

GENERAL AIR CONDITIONING SERVICE GUIDELINES (CONT'D)

Compressor Oil Check

Figure 80-60-2

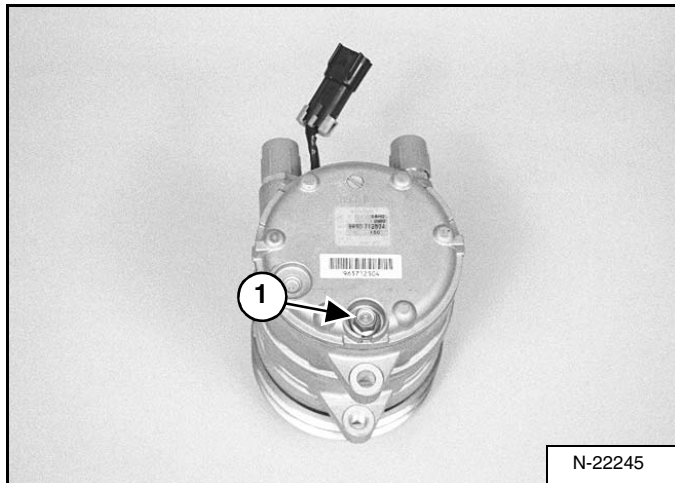
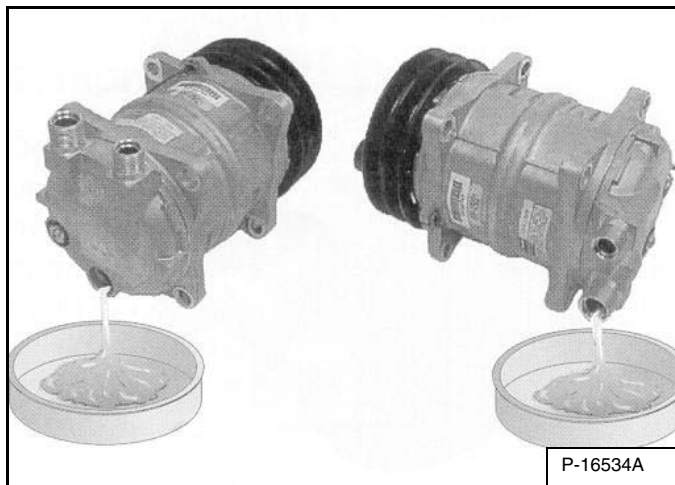

Figure 80-60-3



The compressor oil should be checked as follows when oil is being added to an in service loader.

There is a close affinity between oil and refrigerant. During normal operation, part of the oil circulates with the refrigerant in the system. Therefore, when checking the amount of oil in the system or replacing any system component, the compressor must be run in advance to insure return of oil to the compressor.

If the amount of refrigerant in the system has decreased, charge the system. (See SYSTEM CHARGING AND RECLAMATION on Page 80-100-1.)

Open the cab door and windows.

Run the blower at maximum speed.

Run the compressor for at least 20 minutes at 800-1200 RPM.

Remove the compressor from the loader. (See Removal And Installation on Page 10-110-1.)

Remove the oil drain plug (Item 1) [Figure 80-60-2] and drain the oil through the connectors and the oil drain hole [Figure 80-60-3].

Installation: Tighten the oil drain plug to 9.4 - 10.8 ft.-lb. (13 - 15 N•m) torque.

Figure 80-60-4

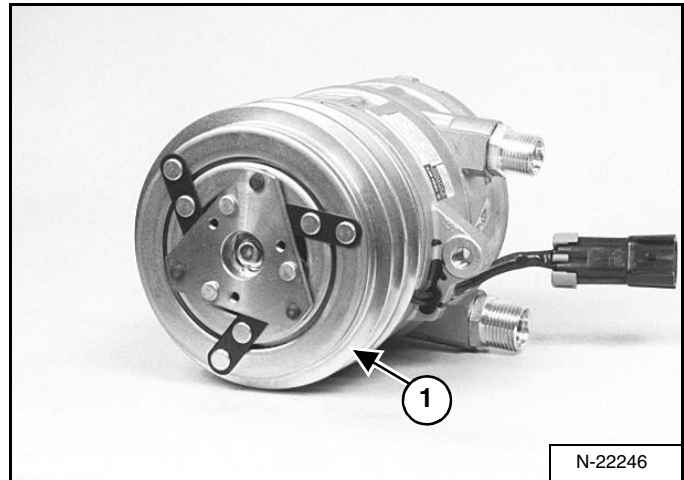

NOTE: After draining the oil through the drain hole and the connectors, extract the remaining oil through the discharge-side connector by rotating the drive pulley (Item 1) [Figure 80-60-4] several times by hand.



Bobcat®

COMPRESSOR (CONT'D)

Compressor Clutch Disassembly (Cont'd)

Figure 80-110-11

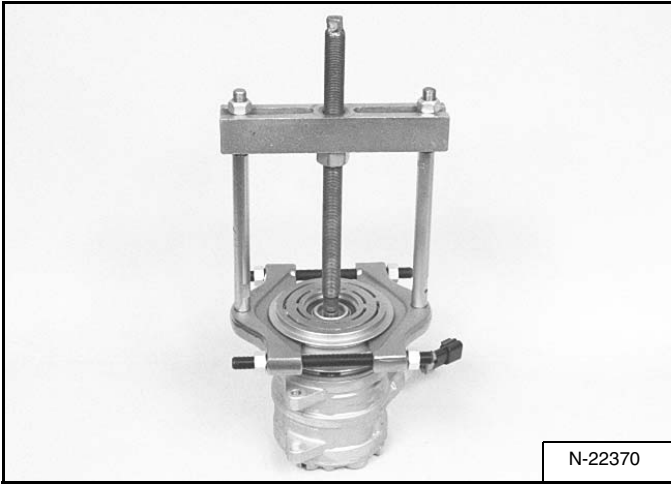

Remove the pulley from the compressor [Figure 80-110-11].

Figure 80-110-12

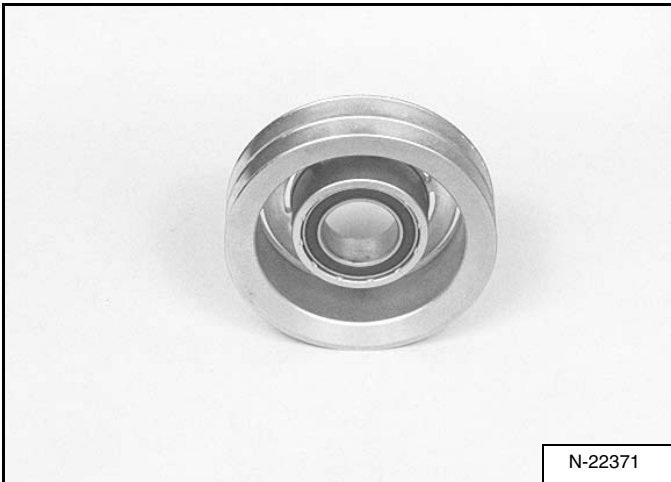

The pulley assembly and bearing [Figure 80-110-12] must be replaced as a complete unit.

Figure 80-110-13

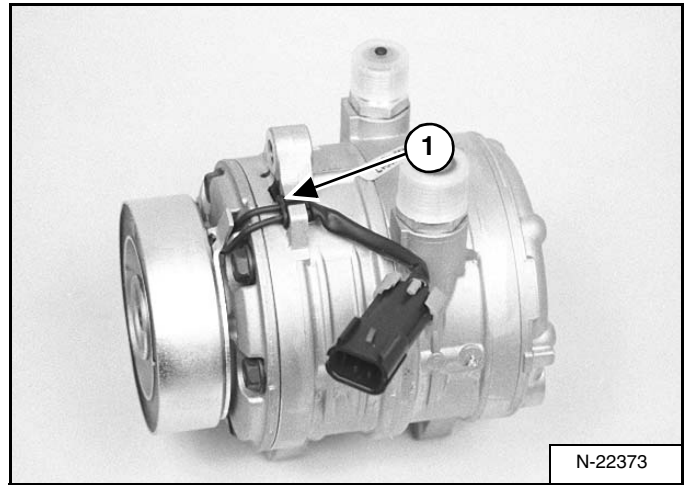

Slide the wire grommet (Item 1) [Figure 80-110-13] from the wire holder.

Figure 80-110-14

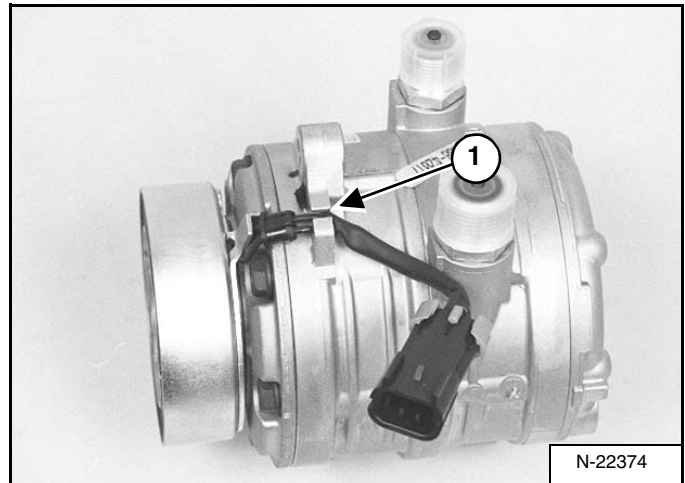

Remove the coil lead wire (Item 1) [Figure 80-110-14] from the wire holder on the compressor.

PRESSURE SWITCH (CONT'D)

Shreader Valve Removal And Installation

Figure 80-150-3

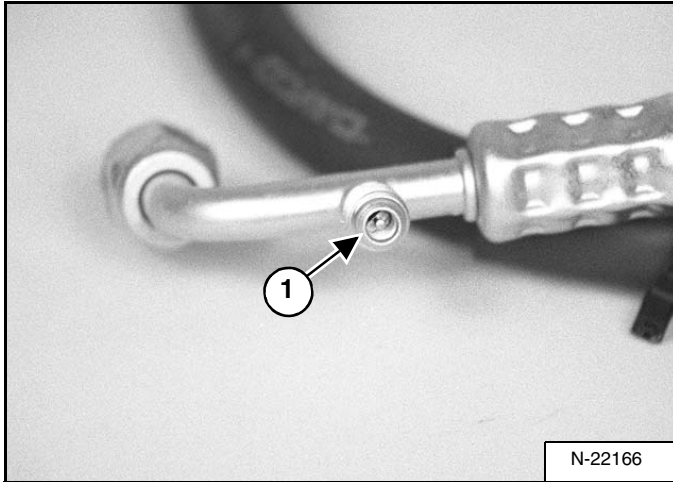

The shreader valve (Item 1) **[Figure 80-150-3]** is located in the A/C high pressure hose and is located under the pressure switch.

Raise the loader lift arms and install an approved lift arm support device. (See LIFT ARM SUPPORT DEVICE on Page 10-20-1.)

Raise the operator cab. (See Raising The Operator Cab on Page 10-30-1.)

Remove the refrigerant from the A/C system. (See Reclamation Procedure on Page 80-100-1.)

Remove the pressure switch.

With a tire valve core removal tool, remove the valve core from the hose.

Replace with a new core.

HEATER COIL (CONT'D)

Removal And Installation With A/C (Cont'd)

Figure 80-200-4

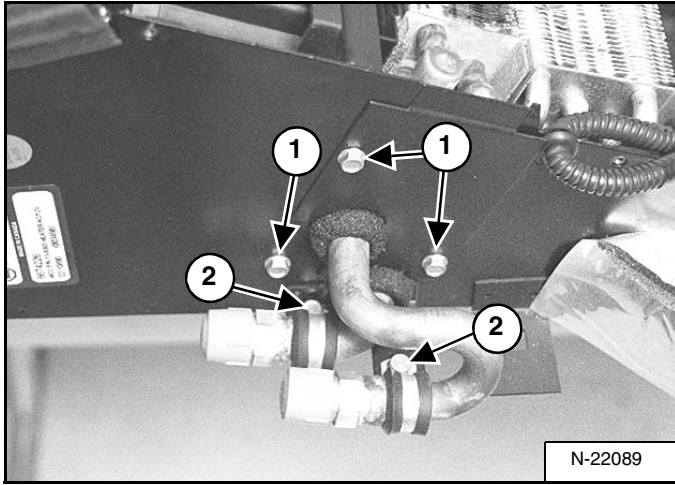

Remove the three mount bolts (Item 1) [Figure 80-200-4] and remove the mount plate from the end of the unit.

Remove the two mount bolts (Item 2) [Figure 80-200-4] that support the heater coil tubelines to the unit.

Remove the heater coil from the unit.

Figure 80-200-5

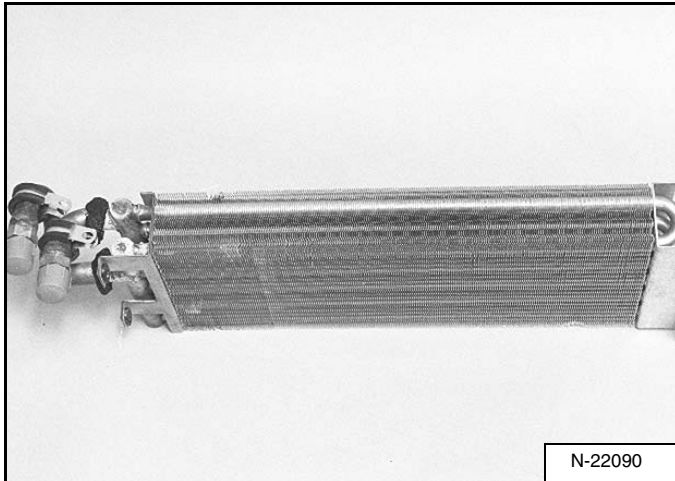

The heater coil [Figure 80-200-5] can be cleaned with low air or water pressure.

If the heater coil needs replacement it must be replaced as complete unit.

Removal And Installation Without A/C

Raise the lift arms and install an approved lift arm support device. (See LIFT ARM SUPPORT DEVICE on Page 10-20-1.)

Raise the operator cab. (See Raising The Operator Cab on Page 10-30-1.)

Remove the heater unit from the back of the cab. (See Removal And Installation Without A/C on Page 80-200-2.)

Figure 80-200-6

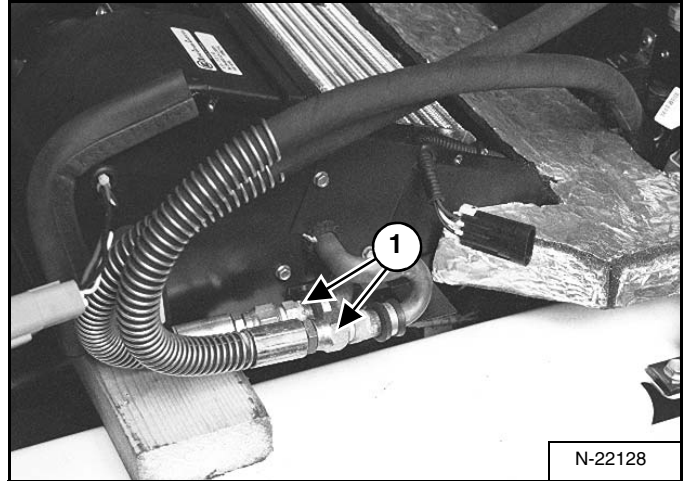

Mark the heater hoses (Item 1) [Figure 80-200-6] for proper installation.

Remove the two heater hoses from the heater coil.

Cap the hoses and the heater coil with hydraulic caps and plugs to prevent oil loss from the system.

Installation: Tighten the two heater hose fittings to 22 ft.-lb. (29,8 N•m) torque.

Remove the rear cover from the evaporator / heater unit. (See Disassembly And Assembly on Page 80-160-2.)



Bobcat®

ENGINE SPECIFICATIONS (CONT'D)

All dimensions are given in inches. Respective metric dimensions are given in millimeters enclosed by parentheses.

Cylinder Head and Block

| | |
|------------------------------|--------------------------|
| Cylinder Head Studs - Length | 5.906±0.031 (150,0±0,8) |
| Cylinder Bore | 3.583+0.0008 (91,0+0,02) |
| Wear Limit | 3.587 (91,1) |

Crankshaft and Main Bearings

| | |
|--------------------------------|--------------------------------------|
| Crankshaft Pin Width | 1.220 (31,0) |
| Crankshaft Pin Diameter | 2.165-0.0004-0.0012 (55,0-0,01-0,03) |
| Oval Wear Limit | 0.0004 (0,01) |
| Crankshaft Journal Width | 1.378+0.0016 (35,0+0,04) |
| Crankshaft Journal Diameter | 2.756-0.0004-0.0012 (70,0-0,01-0,03) |
| Oval Wear Limit | 0.0003 (0,008) |
| Eccentricity Max. Permitted | 0.002 (0,05) |
| Thrust Bearing Journal Width | 1.378+0.002 (35,0+0,04) |
| Main Bearing Shell I.D. | 2.757-2.758 (70,02-70,055) |
| Radial Clearance | 0.0011-0.0033 (0,03-0,084) |
| Wear Limit | 0.0047 (0,12) |
| Bearing Bore in Crankcase | 2.953+0.0007 (75,0+0,019) |
| Thrust Bearing Stop Rings O.D. | 1.374-0.005 (34,9-0,133) |
| Oversize | 0.0157 (0,4) |
| Limit for Oversize | 1.406-0.0052 (35,7-0,133) |
| Crankshaft End Play | 0.0039-0.0106 (0,1-0,27) |
| Wear Limit | 0.016 (0,4) |

Camshaft and Bearings

| | |
|-----------------------|----------------------------|
| Camshaft End Play | 0.0118-0.0236 (0,3-0,6) |
| Wear Limit | 0.0315 (0,8) |
| Camshaft Bearing I.D. | 2.126+0.0021 (54,0+0,054) |
| Wear Limit | 2.129 (54,08) |
| Radial Clearance | 0.0019-0.0048 (0,05-0,124) |
| Cam Lift (Intake) | 0.260 (6,6) |
| Cam Lift (Exhaust) | 0.268 (6,8) |

Oil Pump

| | |
|---|------------------------------|
| Oil Pump Pressure Setting | 101.5 PSI (700 kPa) (7 bar) |
| Min. Eng. Oil Pressure, Oil Temp. 230°F (110°C) at 900RPM | 20.3 PSI (140 kPa) (1.4 bar) |
| 1800 RPM | 31.9 PSI (220 kPa) (2.2 bar) |
| 2800 RPM | 43.5 PSI (300 kPa) (3.0 bar) |
| Thermostat Rating | 203°F (95°C) |

HYDRAULIC CONNECTION SPECIFICATIONS (CONT'D)

O-ring Flare Fitting (Cont'd)

Figure SPEC-50-6

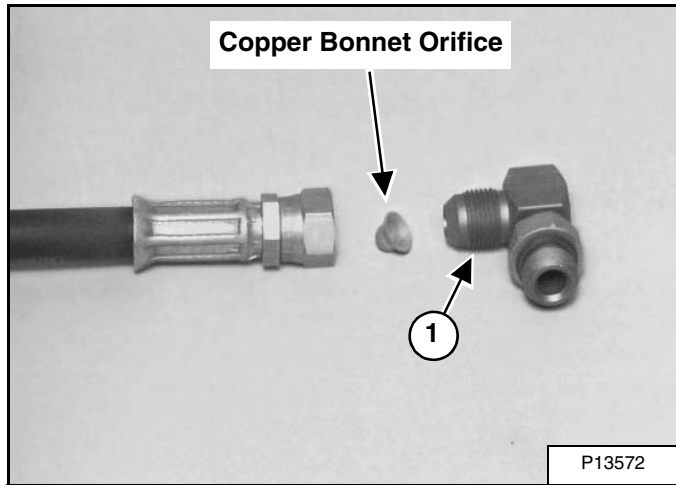

NOTE: O-ring flare fittings are not recommended in all applications. Use the standard flare fittings in these applications.

Do not use a O-ring flare fitting when a copper bonnet orifice is used. When tightened the connection at the bonnet may distort the flare face and prevent it from sealing.

Use a standard flare fitting (Item 1) [Figure SPEC-50-6] as shown.

When a O-ring flare fitting is used as a straight thread port adapter the O-ring flare face is not used to seal. The O-ring may come off the fitting and enter the system.

Figure SPEC-50-7

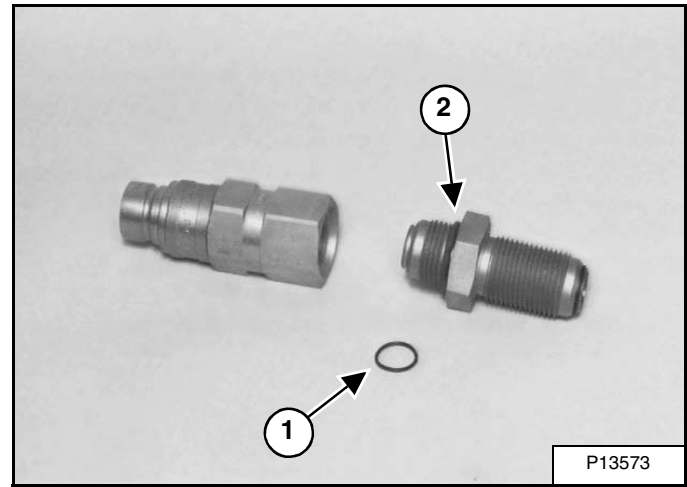

Always remove the O-ring (Item 1) [Figure SPEC-50-7] from the flare face as shown.

An O-ring (Item 2) [Figure SPEC-50-7] is added to the flat boss of the fitting to seal the connection in this application.

CLICK HERE TO **DOWNLOAD** THE COMPLETE MANUAL

- Thank you very much for reading the preview of the manual.
- You can download the complete manual from: www.heydownloads.com by clicking the link below



- Please note: If there is no response to CLICKING the link, please download this PDF first and then click on it.

CLICK HERE TO **DOWNLOAD** THE COMPLETE MANUAL