



Bobcat®

Service Manual



576

Compact Track Loader

B4CD11001 & Above



CLICK HERE TO **DOWNLOAD** THE COMPLETE MANUAL

- Thank you very much for reading the preview of the manual.
- You can download the complete manual from: www.heydownloads.com by clicking the link below



- Please note: If there is no response to CLICKING the link, please download this PDF first and then click on it.

CLICK HERE TO **DOWNLOAD** THE COMPLETE MANUAL

SAFETY INSTRUCTIONS



Safety Alert Symbol

This symbol with a warning statement means:
“Warning, be alert! Your safety is involved!”
Carefully read the message that follows.



WARNING

AVOID INJURY OR DEATH

Instructions are necessary before operating or servicing machine. Read and understand the Operation & Maintenance Manual, Operator's Handbook and signs (decals) on machine. Follow warnings and instructions in the manuals when making repairs, adjustments or servicing. Check for correct function after adjustments, repairs or service. Untrained operators and failure to follow instructions can cause injury or death.

W-2003-0807

IMPORTANT

This notice identifies procedures which must be followed to avoid damage to the machine.

I-2019-0284



DANGER

The signal word DANGER on the machine and in the manuals indicates a hazardous situation which, if not avoided, will result in death or serious injury.

D-1002-1107



WARNING

The signal word WARNING on the machine and in the manuals indicates a potentially hazardous situation which, if not avoided, could result in death or serious injury.

W-2044-1107

The following publications provide information on the safe use and maintenance of the Bobcat machine and attachments:

- The Delivery Report is used to assure that complete instructions have been given to the new owner and that the machine is in safe operating condition.
- The Operation & Maintenance Manual delivered with the machine or attachment contains operating information as well as routine maintenance and service procedures. It is a part of the machine and can be stored in a container provided on the machine. Replacement Operation & Maintenance Manuals can be ordered from your Bobcat dealer.
- Machine signs (decals) instruct on the safe operation and care of your Bobcat machine or attachment. The signs and their locations are shown in the Operation & Maintenance Manual. Replacement signs are available from your Bobcat dealer.
- An Operator's Handbook fastened to the operator cab. It's brief instructions are convenient to the operator. The handbook is available from your dealer in an English edition or one of many other languages. See your Bobcat dealer for more information on translated versions.
- The AEM Safety Manual delivered with the machine gives general safety information.
- The Service Manual and Parts Manual are available from your dealer for use by mechanics to do shop-type service and repair work.
- The Skid-Steer Loader Operator Training Course is available through your local dealer or at **Bobcat.com/training** or **Bobcat.com**. This course is intended to provide rules and practices of correct operation of the skid-steer loader. The course is available in English and Spanish versions.
- Service Safety Training Courses are available from your Bobcat dealer or at **Bobcat.com/training** or **Bobcat.com**. They provide information for safe and correct service procedures.
- The Skid-Steer Loader Safety Video is available from your Bobcat dealer or at **Bobcat.com/training** or **Bobcat.com**.

SI SSL-1016 SM

EMERGENCY EXITS	10-200-1
Removing Rear Window With Latches	10-200-1
Removing Rear Window With Rubber Cord	10-200-1
Removing Rear Window With Latches From Outside Loader	10-200-2
Removing Rear Window With Rubber Cord From Outside Loader	10-200-3
Removing Front Door	10-200-3
Front Door Reassembly	10-200-4
SEAT BELT	10-210-1
Inspection And Maintenance	10-210-1

OPERATOR CAB (CONT'D)

Raising Operator Cab (Cont'd)

Figure 10-30-5

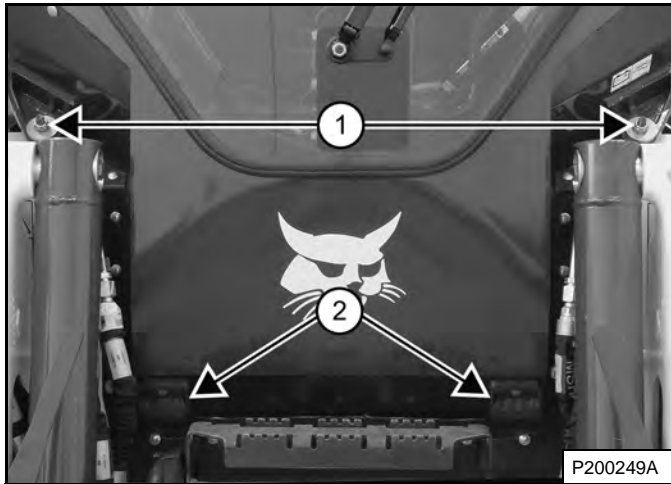

5. Remove the nuts and washers (Item 1) [Figure 10-30-5] at the front corners of the operator cab.
6. Lift on the grab handles (Item 2) [Figure 10-30-5] at the bottom of the operator cab.

Figure 10-30-6



7. Push the bottom of the operator cab [Figure 10-30-6] slowly until the operator cab is all the way up and the latching mechanism engages.

Always stop the engine before raising or lowering the operator cab.

Figure 10-30-7



1. Pull down on the bottom of the operator cab until stopped by the latching mechanism [Figure 10-30-7].

NOTE: The weight of the operator cab increases when equipped with options and accessories, such as: cab door, heater, and air conditioning. In these cases, the operator cab may need to be raised slightly from the latch to be able to release the latch.

! WARNING

PINCH POINT CAN CAUSE INJURY

Remove your hand from the latching mechanism when the cab is past the latch stop.

W-2469-0803

REMOTE START TOOL (SERVICE TOOL) KIT - 7217666

Description

The Remote Start Tool (Service Tool) Kit is a replacement tool for MEL1563 Remote Start Tool and MEL1400B - BOSS® Diagnostic Tool.

The Remote Start Tool (Service Tool) Kit, P/N 7217666, can be used to service newer loaders using the supplied harness P/N 6689747.

A computer can be connected to the Remote Start Tool (Service Tool) for diagnostics and software updates using the computer harness P/N 6689746 in conjunction with the loader harness.

SERVICE SCHEDULE (CONT'D)

Maintenance Intervals (Cont'd)

Every 250 Hours or Every 12 Months

Accessory Drive Belt (Alternator, air conditioning, water pump)	Check condition. Replace as needed.
Bobcat Interlock Control System (BICS™)	Check the function of the lift arm bypass control.
Battery	Check cables and connections.

Every 750 Hours or Every 12 Months

Engine Oil and Filter	Replace oil and filter element.
-----------------------	---------------------------------

Every 1000 Hours or Every 12 Months

Hydraulic Filters	Replace the hydraulic main, case drain, and charge filters.
Hydraulic Reservoir	Replace the fluid and reservoir vent filter.
Final Drive Transmissions (Chaincases)	Replace the fluid.
Heater Coil and Air Conditioning Evaporator (if equipped)	Clean the heater coil and air conditioning evaporator. Clean the plenum drain.
Fuel System	Replace fuel pre-filter element and fuel tank vent filter.

Every 1500 Hours or Every 24 Months

Coolant	Replace the coolant.
---------	----------------------

FUEL SYSTEM

Fuel Specifications

NOTE: Contact your local fuel supplier to receive recommendations for your region.

U.S. Standard (ASTM D975)

Use only clean, high quality diesel fuel, Grade Number 2-D or Grade Number 1-D.

Ultra low sulfur diesel fuel must be used in this machine. Ultra low sulfur is defined as 15 mg/kg (15 ppm) sulfur maximum.

The following is one suggested blending guideline that should prevent fuel gelling during cold temperatures:

TEMPERATURE	GRADE 2-D	GRADE 1-D
Above -9°C (+15°F)	100%	0%
Down to -21°C (-5°F)	50%	50%
Below -21°C (-5°F)	0%	100%

NOTE: Biodiesel blend fuel may also be used in this machine. Biodiesel blend fuel must contain no more than five percent biodiesel mixed with ultra low sulfur petroleum based diesel. This biodiesel blend fuel is commonly marketed as B5 blended diesel fuel. B5 blended diesel fuel must meet ASTM specifications.

E.U. Standard (EN590)

Use only clean, high quality diesel fuel that meets the EN590 specifications listed below:

- Ultra low sulfur diesel fuel defined as 10 mg/kg (10 ppm) sulfur maximum
- Diesel fuel with cetane number of 51.0 and above.

NOTE: Biodiesel blend fuel may also be used in this machine. Biodiesel blend fuel must contain no more than seven percent biodiesel mixed with ultra low sulfur petroleum based diesel. This biodiesel blend fuel is commonly marketed as B7 blended diesel fuel. B7 blended diesel fuel must meet EN590 specifications.

Biodiesel Blend Fuel

Biodiesel blend fuel has unique qualities that should be considered before using in this machine:

- Cold weather conditions can lead to plugged fuel system components and hard starting.
- Biodiesel blend fuel is an excellent medium for microbial growth and contamination that can cause corrosion and plugging of fuel system components.
- Use of biodiesel blend fuel may result in premature failure of fuel system components, such as: plugged fuel filters and deteriorated fuel lines.
- Shorter maintenance intervals may be required, such as: cleaning the fuel system and replacing fuel filters and fuel lines.
- Using biodiesel blended fuels containing more than five percent biodiesel can affect engine life and cause deterioration of hoses, tubelines, injectors, injector pump, and seals.

Apply the following guidelines if biodiesel blend fuel is used:

- Ensure the fuel tank is as full as possible at all times to prevent moisture from collecting in the fuel tank.
- Ensure that the fuel tank cap is securely tightened.
- Biodiesel blend fuel can damage painted surfaces, remove all spilled fuel from painted surfaces immediately.
- Drain all water from the fuel filter daily before operating the machine.
- Do not exceed engine oil change interval. Extended oil change intervals can cause engine damage.
- Before machine storage; drain the fuel tank, refill with 100% petroleum diesel fuel, add fuel stabilizer, and operate the engine for at least 30 minutes.

NOTE: Biodiesel blend fuel does not have long term stability and should not be stored for more than 3 months.

ENGINE LUBRICATION SYSTEM (CONT'D)

Replacing Engine Oil And Filter (Cont'd)

Figure 10-110-6

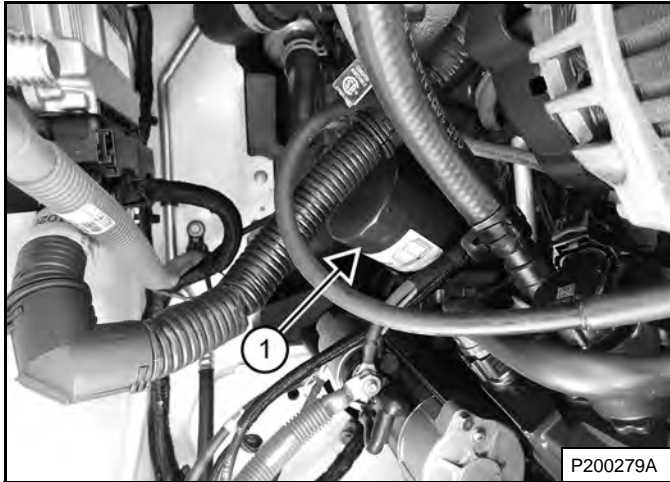

11. Remove the oil filter (Item 1) [Figure 10-110-6].

The oil filter is located on the left side of the engine compartment.

12. Clean the filter base.
13. Put clean oil on the new filter gasket.
14. Install the new filter and hand tighten.

Use genuine Bobcat filter only.

Figure 10-110-7

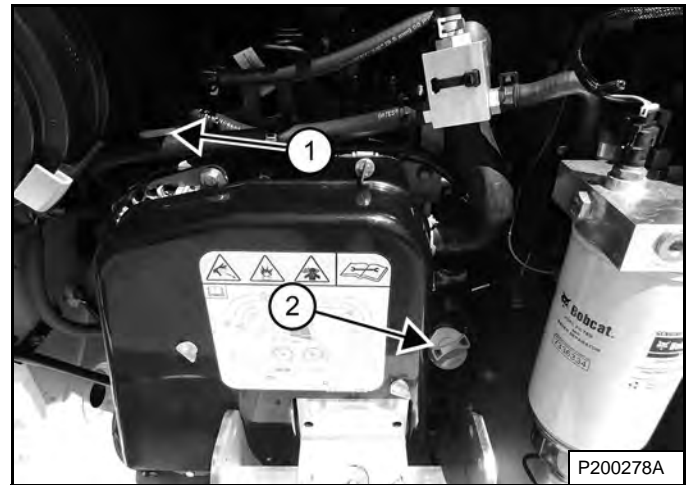

15. Remove the oil fill cap (Item 2) [Figure 10-110-7].
16. Put oil into the engine and replace the oil fill cap. (See Fluid Capacities on Page SPEC-10-6.) Do not overfill.
17. Start the engine and allow to operate for several minutes.
18. Stop the engine.
19. Check for leaks at the filter.
20. Remove the dipstick (Item 1) [Figure 10-110-7] and check the oil level.
21. Add oil as needed if oil level is not at the top mark on the dipstick.
22. Install the dipstick.
23. Close the rear door.

WARNING

AVOID INJURY OR DEATH

Always clean up spilled fuel or oil. Keep heat, flames, sparks or lighted tobacco away from fuel and oil. Failure to use care around combustibles can cause explosion or fire.

W-2103-0508

HYDRAULIC SYSTEM (CONT'D)

Replacing Hydraulic Case Drain Filter

See the SERVICE SCHEDULE for the correct service interval. (See SERVICE SCHEDULE on Page 10-70-1.)

1. Stop the engine.
2. Raise the operator cab. (See Raising Operator Cab on Page 10-30-2.)

Figure 10-120-18

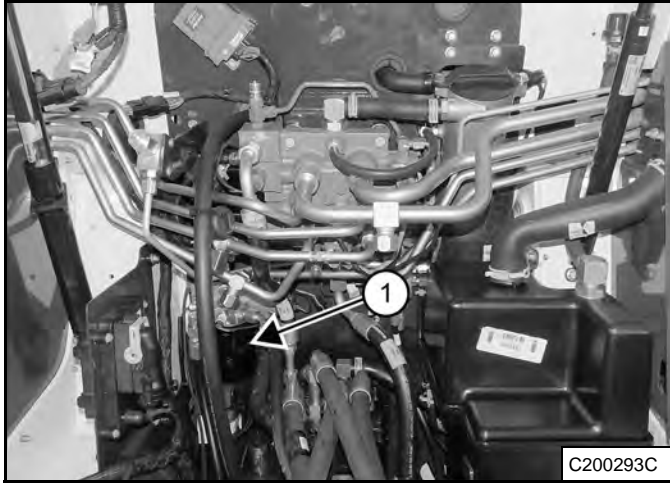

3. Locate the filter (Item 1) [Figure 10-120-18].

Figure 10-120-19

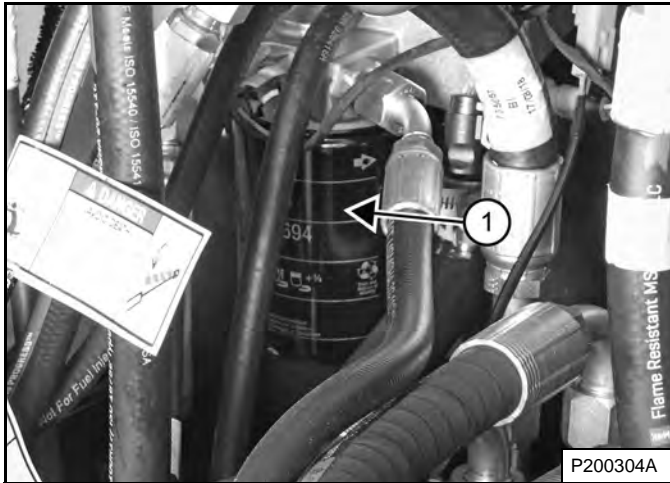

4. Put a suitable container below the filter, remove the filter (Item 1) [Figure 10-120-19] and discard.
5. Clean the filter base.
6. Put clean oil on the new filter gasket.
7. Install the new filter and tighten to 18 – 23 N•m (13 – 17 ft-lb) torque.

8. Recycle or dispose of used fluid in an environmentally safe manner.

! WARNING

AVOID INJURY OR DEATH

Always clean up spilled fuel or oil. Keep heat, flames, sparks or lighted tobacco away from fuel and oil. Failure to use care around combustibles can cause explosion or fire.

W-2103-0508

9. Lower the operator cab. (See Lowering Operator Cab on Page 10-30-4.)
10. Start the engine and operate the loader hydraulic controls.
11. Stop the engine.

! WARNING

AVOID INJURY OR DEATH

Diesel fuel or hydraulic fluid under pressure can penetrate skin or eyes, causing serious injury or death. Fluid leaks under pressure may not be visible. Use a piece of cardboard or wood to find leaks. Do not use your bare hand. Wear safety goggles. If fluid enters skin or eyes, get immediate medical attention from a physician familiar with this injury.

W-2072-0807

12. Check for leaks at the filter.
13. Check the fluid level in the reservoir and add as needed. (See Checking And Adding Hydraulic Fluid on Page 10-120-1.)

LUBRICATING THE LOADER

Lubricating Grease Fittings

See the SERVICE SCHEDULE for the correct service interval. (See SERVICE SCHEDULE on Page 10-70-1.)

Record the operating hours each time you lubricate the Bobcat loader.

Always use a good quality lithium based multipurpose grease when you lubricate the loader. Apply the lubricant until extra grease shows.

1. Remove attachment from the loader.
2. Stop the engine.
3. Lubricate the following grease fittings:

Figure 10-150-1

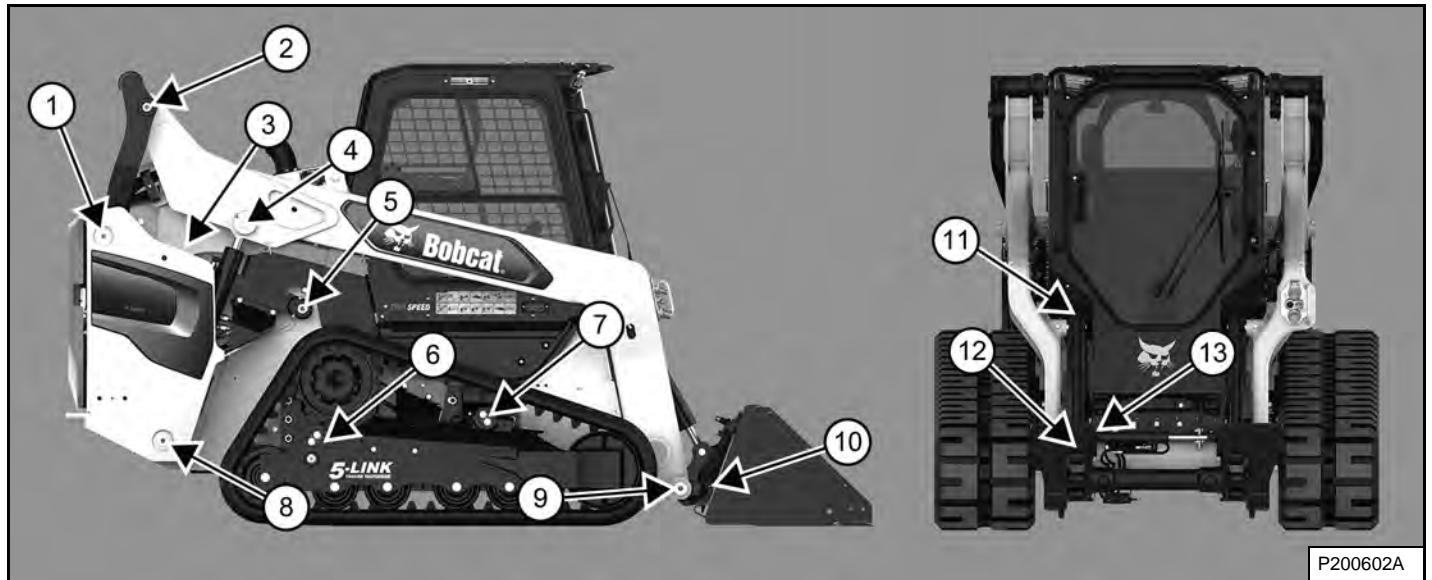

REF.	DESCRIPTION	QUANTITY
1	Lower Follower Link	1 per side
2	Upper Follower Link	1 per side
3	Rear Driver Assembly	1 per side
4	Rod End Lift Cylinder	1 per side
5	Front Driver Assembly	1 per side
6	Rear Torsion Axle Spindle	3 per side
7	Front Torsion Axle Spindle	2 per side
8	Base End Lift Cylinder	1 per side
9	Bob-Tach Pivot Pin	1 per side
10	Bob-Tach Wedge Pin	1 per side
11	Base End Tilt Cylinder	1 per side
12	Rod End Tilt Cylinder	1 per side
13	Power Bob-Tach Hydraulic Cylinder (If equipped)	1 per side

EMERGENCY EXITS

The front opening on the operator cab and the rear window provide exits.

Removing Rear Window With Latches

Figure 10-200-1

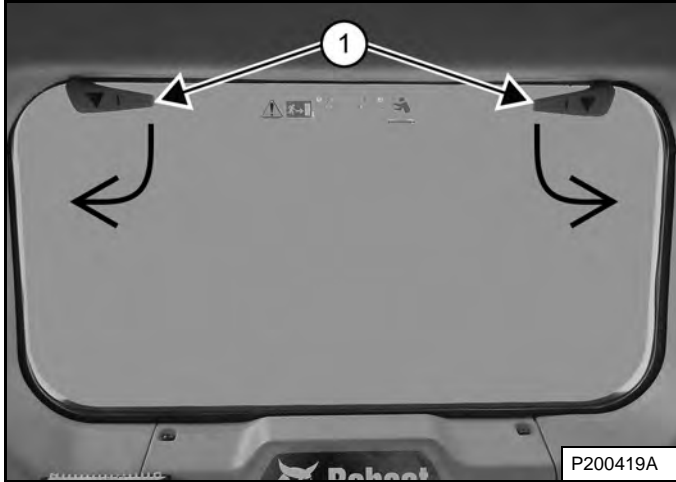

1. Turn both latches (Item 1) [Figure 10-200-1] in until they disengage from the window frame.
2. Push the rear window out of the rear of the operator cab.
3. Exit through the rear of the operator cab.

NOTE: Use this procedures to remove the rear window only under emergency conditions. Damage to machine may occur.

Removing Rear Window With Rubber Cord

Figure 10-200-2



1. Pull on the tag on the top of the rear window to remove the rubber cord [Figure 10-200-2].
2. Push the rear window out of the rear of the operator cab.
3. Exit through the rear of the operator cab.

NOTE: Use this procedure to remove the rear window only under emergency conditions. Damage to machine may occur.

HYDRAULIC/HYDROSTATIC SCHEMATIC MANUAL WITH NO OPTIONS S76 (S/N B4CD110011 AND ABOVE)

(PRINTED MAY 2020)
V-1708 legend





LEGEND

- | | | |
|--|--|---|
| <p>① RESERVOIR:
Capacity at sight gauge . . 12 L (3.2 U.S. gal)
System Capacity 51,1 L (13.5 U.S. gal)</p> <p>② SIGHT GAUGE</p> <p>③ FILTER RESITRICTION PRESSURE SWITCH: 107 kPa (1,07 bar) (15 psi)</p> <p>④ FILTER - HYDRAULIC (CANISTER)</p> <p>⑤ SPRING LOADED FILTER BY-PASS VALVE: 172 kPa (1,7 bar) (25 psi)</p> <p>⑥ DIAGNOSTIC COUPLER</p> <p>⑦ RELIEF VALVE - MAIN:
24132 kPa (241 bar) (3500 psi)
at Front Quick Couplers</p> <p>⑧ RELIEF/ANTICAVITATION VALVE - PORT: 20700 kPa (207 bar) (3000 psi)</p> <p>⑨ RELIEF/ANTICAVITATION VALVE - PORT: 27579 kPa (276 bar) (4000 psi)</p> <p>⑩ SOLENOID ACTIVATED DIRECTIONAL CONTROL VALVE - AUXILIARY</p> <p>⑪ LOAD CHECK VALVE</p> <p>⑫ ANTICAVITATION VALVE</p> <p>⑬ PILOTED ACTIVATED DIRECTIONAL CONTROL VALVE – BICS TILT CONTROL</p> <p>⑭ PILOTED ACTIVATED DIRECTIONAL CONTROL VALVE – BICS LIFT CONTROL</p> <p>⑮ SOLENOID ACTIVATED DIRECTIONAL CONTROL VALVE - BICS CONTROL</p> <p>⑯ FILTER - BICS CONTROL VALVE (SCREEN)</p> <p>⑰ RESERVOIR BREATHER: 10 micron</p> <p>⑱ RESTRICTION</p> | <p>⑲ TWIST & PULL BUTTON ACTIVATED DIRECTIONAL CONTROL VALVE - LIFT ARM BY-PASS</p> <p>⑳ CHARGE PRESSURE TRANSDUCER</p> <p>㉑ NOT USED FOR THIS MODEL</p> <p>㉒ RESTRICTION</p> <p>㉓ PROPORTIONAL RELIEF VALVE – (Fan Speed Regulator): 16547 kPa (165 bar) (2400 psi)</p> <p>㉔ SPRING LOADED FILTER BY-PASS VALVE: 540 kPa (5,4 bar) (79 psi)</p> <p>㉕ FIXED CAPACITY DISPLACEMENT HYDRAULIC MOTOR</p> <p>㉖ FILTER - HYDRAULIC (CANISTER)</p> <p>㉗ TEMP SENSOR (Hydrostatic Pump Case Drain)</p> <p>㉘ TEMP SENSOR (Drive Motor Case Drain)</p> <p>㉙ RESTRICTION</p> <p>㉚ CHECK VALVE - With 1400 kPa 14 bar (200 psi) Spring</p> <p>㉛ FLUSHING SPOOL</p> <p>㉜ NOT USED FOR THIS MODEL</p> <p>㉝ FIXED CAPACITY DISPLACEMENT BIDIRECTIONAL HYDROSTATIC MOTOR</p> <p>㉞ NOT USED FOR THIS MODEL</p> <p>㉟ NOT USED FOR THIS MODEL</p> <p>㊱ AIR BLEED ORFICE</p> <p>㊲ OIL COOLER</p> <p>㊳ COLD WEATHER BY-PASS:
345 kPa (3,45 bar) (50 psi)</p> | <p>㊴ CHARGE PUMP -
62,1 L/min (16.4 U.S. gpm) at High Engine Idle</p> <p>㊵ HYDRAULIC PUMP Gear Type
88,1 L/min (23.3 U.S. gpm) at High Engine Idle</p> <p>㊶ VARIABLE CAPACITY DISPLACEMENT BIDIRECTIONAL HYDROSTATIC PUMP</p> <p>㊷ RELIEF/REPLENISHING VALVE – HIGH PRESSURE:
38000-39900 kPa (380-399 bar) (5511-5787 psi)</p> <p>㊸ NOT USED FOR THIS MODEL</p> <p>㊹ RELIEF VALVE - CHARGE INLET:
3172 +/- 414 kPa (31,7 +/- 4,1 bar)
(460 +/- 60 psi) at High Engine Idle
With 60°C (140°F) Fluid</p> <p>㊺ NOT USED FOR THIS MODEL</p> <p>㊻ NOT USED FOR THIS MODEL</p> <p>㊼ NOT USED FOR THIS MODEL</p> <p>㊽ FRONT AUXILIARY MANUAL PRESSURE BLEED-OFF VALVE</p> <p>㊾ FILTER – DRIVE MOTOR CASE DRAIN</p> <p>㊿ SPRING LOADED FILTER BY-PASS VALVE: 103 kPa (1 bar) (15 psi)</p> <p>① RELIEF/ANTICAVITATION VALVE - PORT (OPTIONAL): 27579 kPa (276 bar) (4000 psi)</p> |
|--|--|---|

NOTE: Unless otherwise specified springs have NO significant pressure value.

HYDRAULIC SYSTEM INFORMATION (CONT'D)

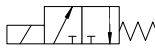
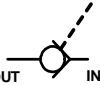
Glossary Of Hydraulic (Cont'd)

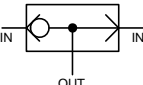
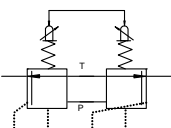
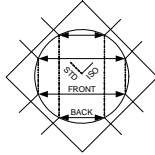
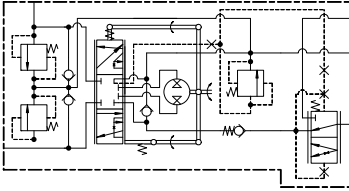
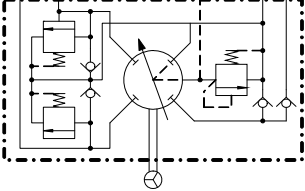
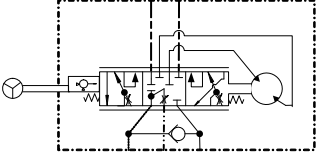
SYMBOL	DESCRIPTION	SYMBOL	DESCRIPTION
	<p>NON-RETURN VALVE (Check Valve) - Used as Replenishing Valve, Lock Check Valve or Anti-cavitation Valve - Opens if the Inlet pressure is higher than the Outlet pressure. Often contains internal spring which has NO significant pressure value.</p>		<p>DIRECTIONAL CONTROL VALVE: Valve providing for the opening (fully or restricted) or the closing of one or more flow paths (represented by several squares).</p> <p>TWO PORTS and CLOSED FLOW PATHS</p>
	<p>SPRING LOADED VALVE (bypass Valve) - Opens if the Inlet pressure is greater than the Outlet pressure plus the spring pressure.</p>		<p>SOLENOID ACTIVATED DIRECTIONAL CONTROL VALVE (Two Position) - controlled by an electric solenoid (with return spring).</p>
	<p>PILOT CONTROLLED NON-RETURN VALVE- It is possible to open the valve by pilot pressure.</p>		<p>PILOT ACTIVATED DIRECTIONAL CONTROL VALVE (Two Position) - controlled by pressure (with return spring).</p>
	<p>SHUTTLE VALVE - The Inlet port connected to the higher pressure is automatically connected to the Outlet port while the other Inlet port is closed.</p>		<p>MANUALLY ACTIVATED DIRECTION CONTROL VALVE (Variable Position) Joystick Controlled, variable pressure to shift the pilot activated directional control valve spool.</p>
			<p>MANUALLY ACTIVATED FLOW CONTROL VALVE (Two Position) allows for changing pilot flow to control switching joystick functions for STD / ISO Control (Excavators Only).</p>
			<p>STEERING CONTROL VALVE (Variable Position) - Used for controlling the hydraulic flow for the steering cylinders in relationship to the amount the steering wheel is rotated.</p>
			
			

CYLINDER (LIFT) (CONT'D)

Disassembly

Use the following tools to disassemble the cylinder:

MEL1074 - O-ring Seal Hook

MEL1075 - Adjustable Gland Nut Wrench

Hold the hydraulic cylinder over a drain pan and move the rod in and out slowly to remove the fluid from the cylinder.

Put the base end of the cylinder in a vise.

Figure 20-20-14

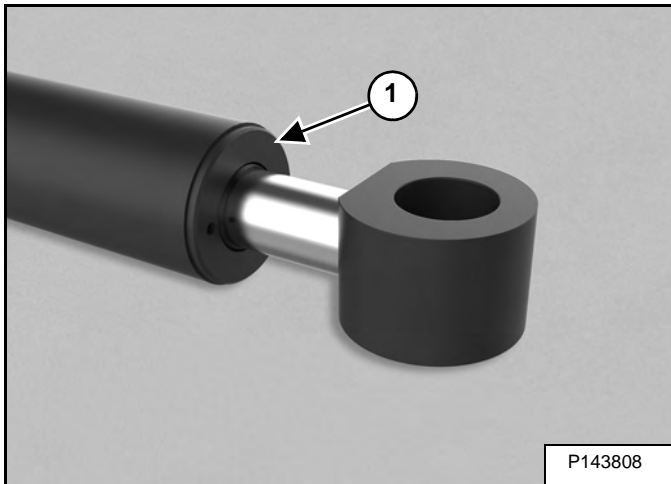

Use a Adjustable Gland Nut Wrench to loosen the head (Item 1) [Figure 20-20-14] from the cylinder tube.

Remove the piston and rod assembly from cylinder tube.

Figure 20-20-15

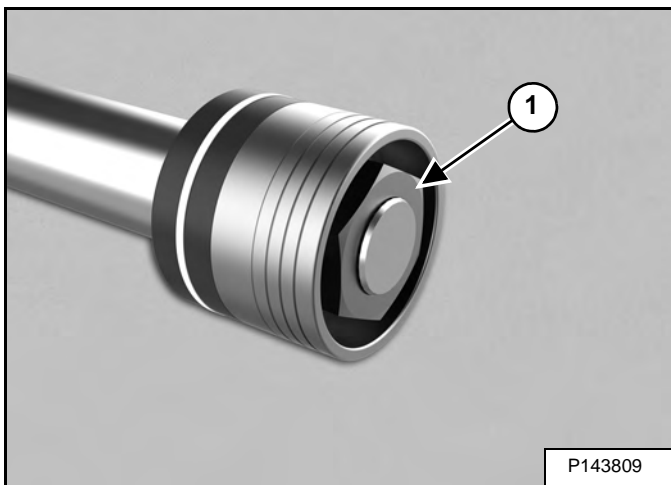

Remove the nut (Item 1) [Figure 20-20-15].

Figure 20-20-16

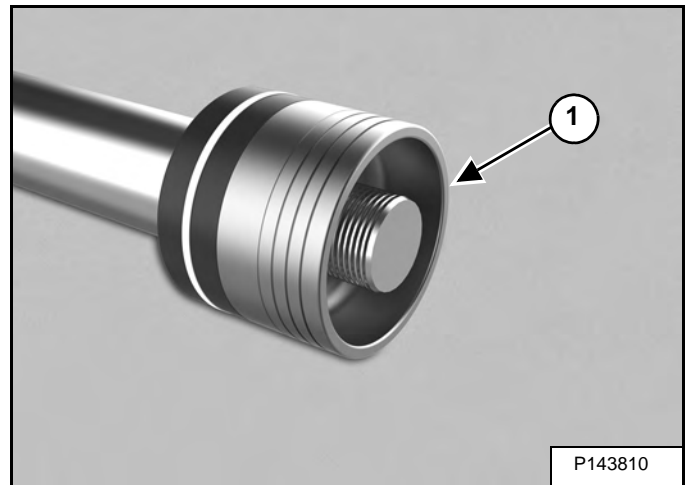

Remove the piston (Item 1) [Figure 20-20-16] from the rod.

Figure 20-20-17

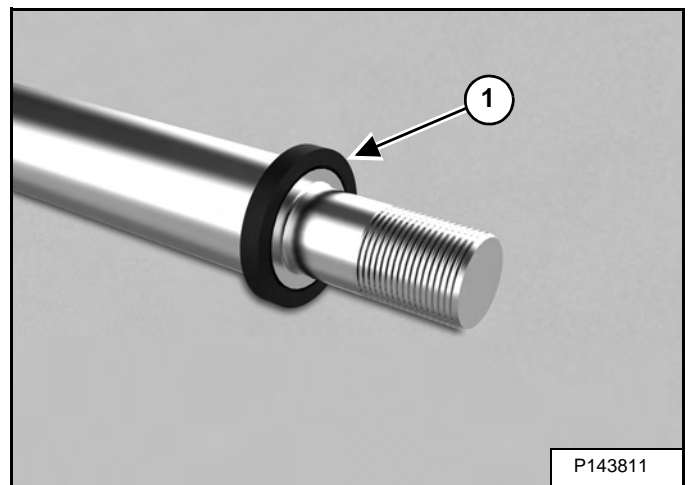

Remove the spacer (Item 1) [Figure 20-20-17].

CYLINDER (TILT) (CONT'D)

Removal And Installation (Cont'd)

Figure 20-21-7



Slide the cylinder from the base pin and remove from the loader **[Figure 20-21-7]**.

CYLINDER (BOB-TACH)

Testing

! WARNING

AVOID INJURY OR DEATH

Diesel fuel or hydraulic fluid under pressure can penetrate skin or eyes, causing serious injury or death. Fluid leaks under pressure may not be visible. Use a piece of cardboard or wood to find leaks. Do not use your bare hand. Wear safety goggles. If fluid enters skin or eyes, get immediate medical attention from a physician familiar with this injury.

W-2072-0807

! WARNING

AVOID INJURY OR DEATH

Always clean up spilled fuel or oil. Keep heat, flames, sparks or lighted tobacco away from fuel and oil. Failure to use care around combustibles can cause explosion or fire.

W-2103-0508

Figure 20-22-1



Tilt the Bob-Tach forward, so it is parallel to the floor [Figure 20-22-1].

Push and hold BOB-TACH “WEDGES UP” switch until levers are in the unlocked position (Wedges fully raised).

Figure 20-22-2

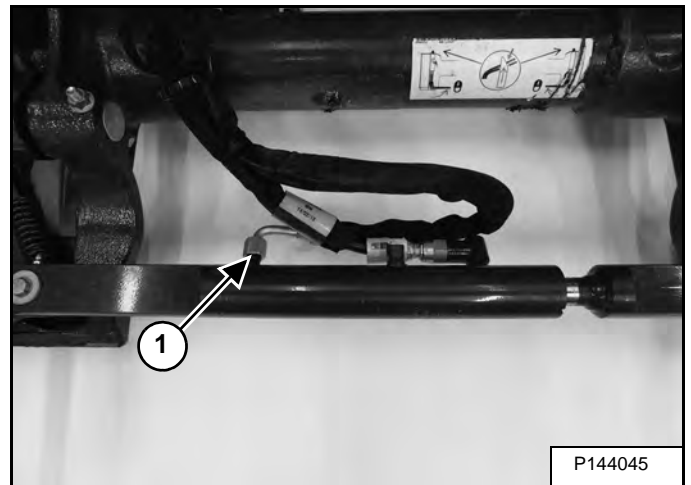

Disconnect the hose (Item 1) [Figure 20-22-2] from the Power Bob-Tach cylinder base end port.

Figure 20-22-3

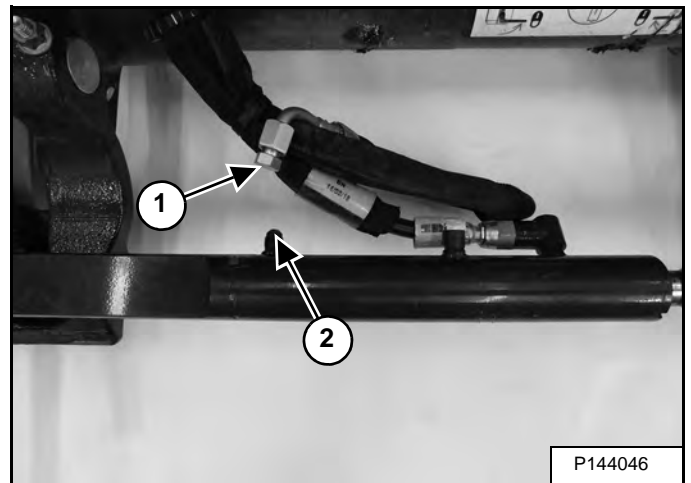

Install a plug (Item 1) [Figure 20-22-3] in the hose and tighten.

Engage the parking brake. Lower the seat bar. Start the engine.

Push and hold the BOB-TACH “WEDGES UP” Switch (Front Accessory Panel).

If there is any leakage from the base end cylinder port (Item 2) [Figure 20-22-3], remove the cylinder for repair.

MAIN RELIEF VALVE (CONT'D)

Testing (Cont'd)

Route the test gauge so it can be used in the operator cab when lowered. Make sure the hose will not interfere with any moving parts.

Lower the operator cab. (See Lowering Operator Cab on Page 10-30-4.)

NOTE: Do not have any attachment connected to the loader auxiliary quick couplers while testing.

Enter the loader and engage the parking brake. Start the engine.

Increase the engine speed to full rpm and make sure the hydraulic fluid is at 60°C (140°F).

The main relief valve setting is 23,8 - 24,5 mPa (238 - 245 bar) (3450 - 3550 psi).

Power loader lift arms down on the stops and monitor the test gauge for the relief pressure setting.

If the relief pressure is not correct, stop the engine and adjust the relief valve. (See Main Relief Valve Adjustment on Page 20-30-4.)

Testing Auxiliary Relief Pressure

The auxiliary relief valve setting is 23787 - 24476 kPa (238 - 245 bar) (3450 - 3550 psi).

Figure 20-30-4

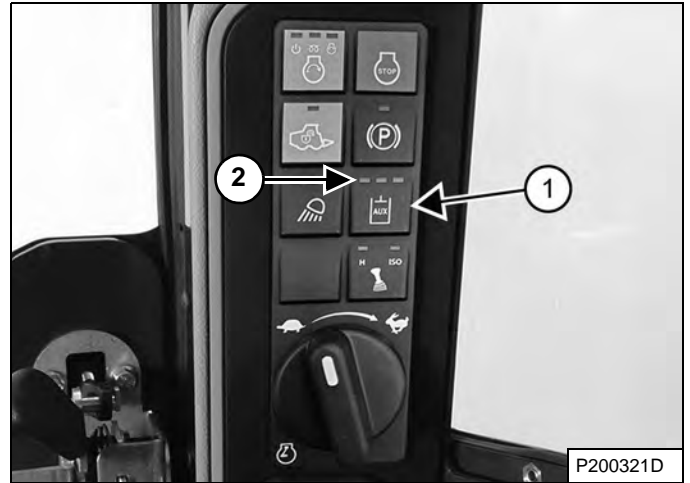

1. Press the auxiliary hydraulics button (Item 1) **[Figure 20-30-4]** on the right control panel once to activate auxiliary hydraulics.

The left LED (Item 2) **[Figure 20-30-4]** in the button will light.

Figure 20-30-5



Move the front auxiliary hydraulic switch (Item 1) **[Figure 20-30-5]** to the left or right and monitor the test gauge for the relief pressure setting.

Stop the machine and exit the loader.

HYDRAULIC CONTROL VALVE (CONT'D)

Actuator Removal And Installation (Cont'd)

Figure 20-40-19

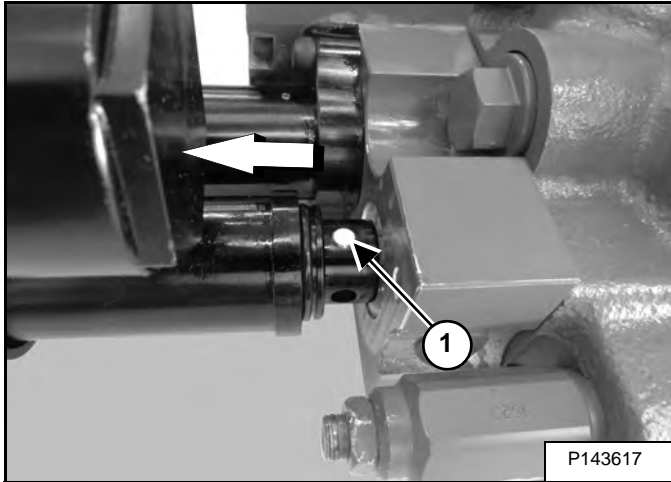

Use a punch to remove the actuator pin (Item 2) [Figure 20-40-19] from the actuator and spool.

Remove the actuator from the hydraulic control valve.

NOTE: The calibration procedure must be followed when replacing a lift or tilt actuator. (See Lift And Tilt Calibration (SJC) on Page 60-150-4.)

Figure 20-40-20

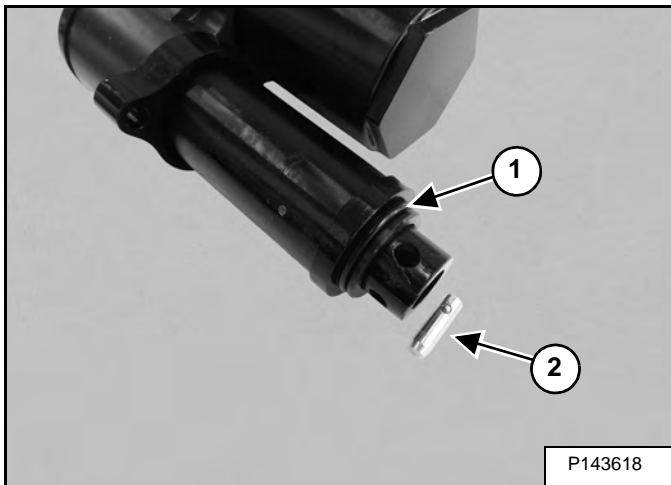

Remove the O-ring (Item 1) [Figure 20-40-20] on the face of the actuator.

Inspect the linkage pin (Item 2) [Figure 20-40-20] and replace as needed.

Figure 20-40-21

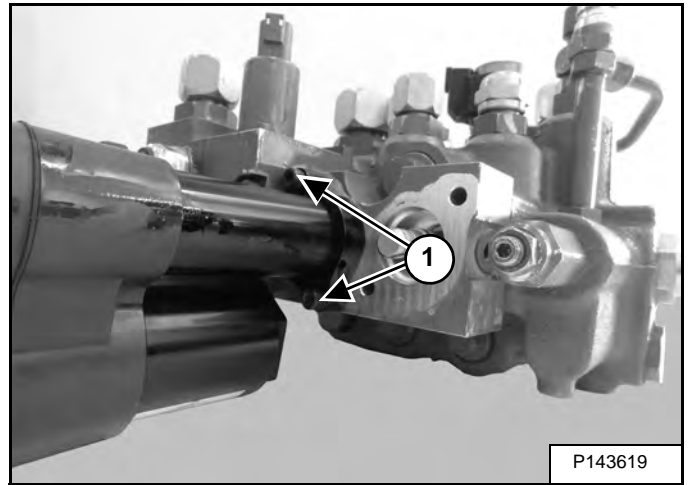

Remove the two mount bolts (Item 1) [Figure 20-40-21] from the actuator.

Installation: Tighten the mounting bolts to 10,2 - 11,3 N•m (90 - 100 in-lb) torque.

Figure 20-40-22

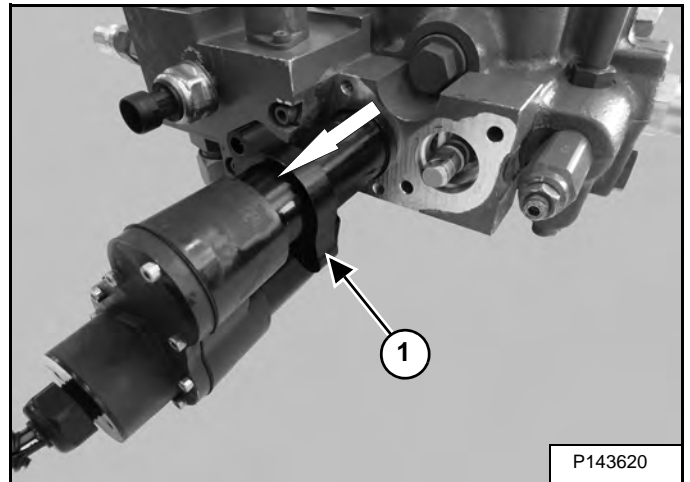

Slide the actuator mount bracket (Item 1) [Figure 20-40-22] away from the control valve.

HYDRAULIC CONTROL VALVE (ACS) OR (SJC) (CONT'D)

End Cap Block Removal And Installation

Remove the lift and tilt actuators from the control valve. (See Actuator Removal And Installation on Page 20-40-6.)

Figure 20-40-52

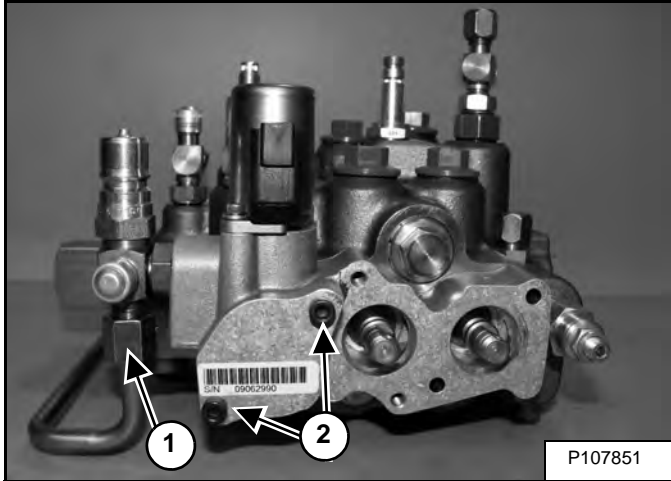

Disconnect the tubeline (Item 1) [Figure 20-40-52] from the end cap block.

Remove the two end cap block mount screws (Item 2) [Figure 20-40-52].

Installation: Lubricate the screws and tighten to 10,4 - 11,6 N•m (95 - 105 in-lb) torque.

Figure 20-40-53

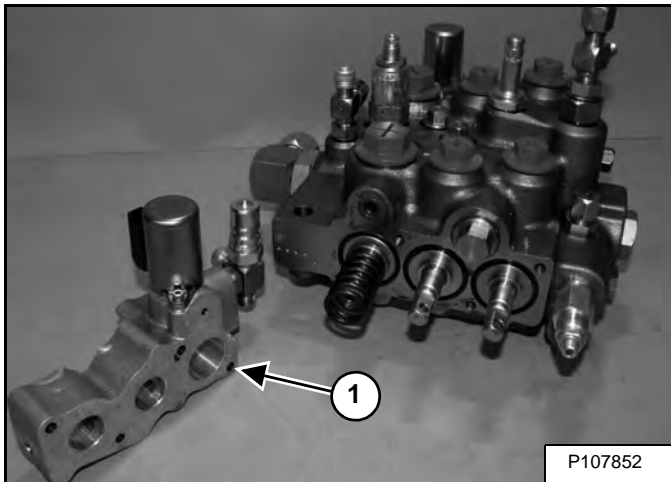

Remove the end cap block (Item 1) [Figure 20-40-53] from the control valve.

Lift Spool Removal And Installation

The tool listed will be needed to do the following procedure:

MEL1285 - Spring Tool

Remove the end cap block from the control valve.

Figure 20-40-54

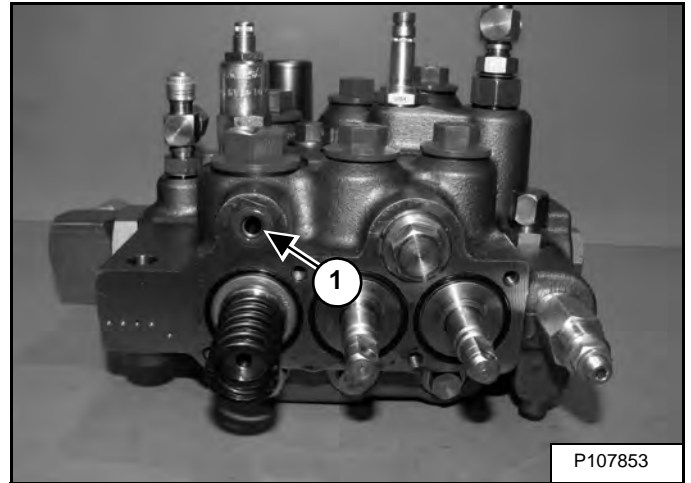

Remove the O-ring (Item 1) [Figure 20-40-54].

Installation: Replace the O-ring, and lubricate lightly with oil before installation of the end cap block.

Figure 20-40-55

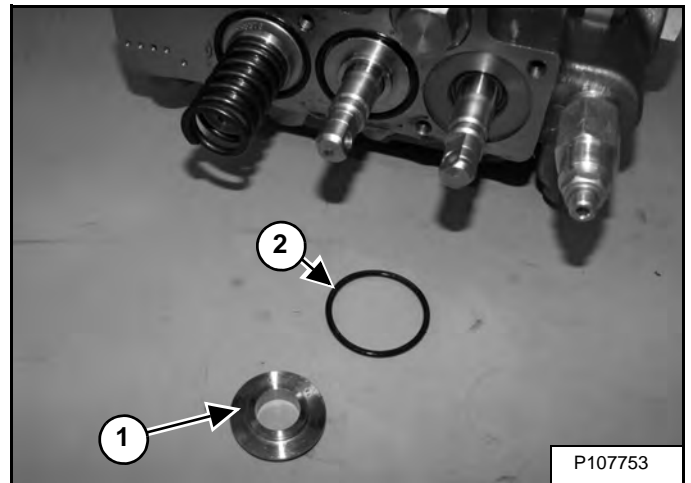

Remove the spacer (Item 1) and O-ring (Item 2) [Figure 20-40-55] from the lift spool.

**HYDRAULIC CONTROL VALVE (ACS) OR (SJC)
(CONT'D)**

Lift Arm Bypass Orifice Removal And Installation

Figure 20-40-89

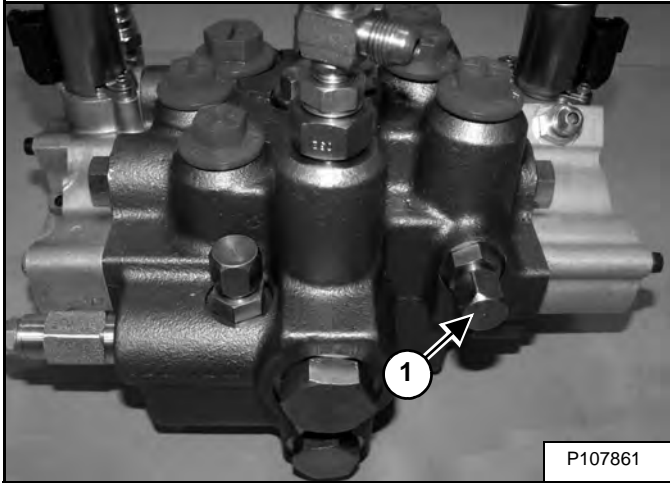

Remove the fitting (Item 1) [Figure 20-40-89] from the valve.

Figure 20-40-90

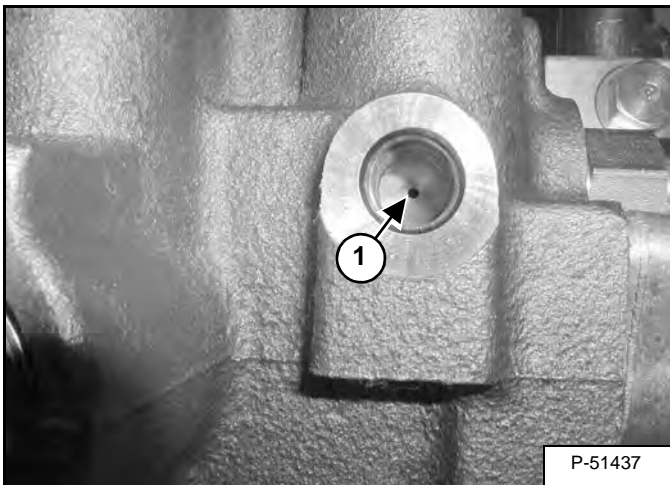

Inspect the lift arm bypass orifice (Item 1) [Figure 20-40-90].

NOTE: This orifice is not removable from the valve casting.

Main Relief Valve Removal And Installation

Figure 20-40-91

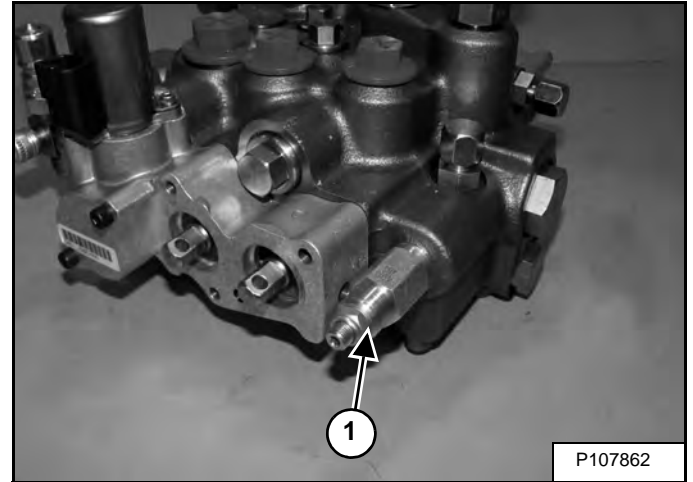

Remove the main relief valve (Item 1) [Figure 20-40-91].

Figure 20-40-92

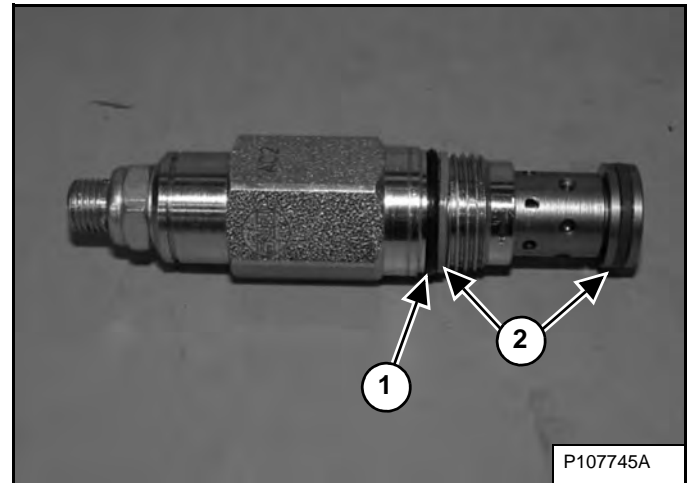

Remove the O-rings (Item 1) [Figure 20-40-92] from the main relief valve.

Installation: Tighten to 52 - 61 N•m (38 - 45 ft-lb) torque.

HYDRAULIC PUMP (CONT'D)

Direct Pump Test (Standard Section) (Cont'd)

Start the engine and run at low idle rpm. Make sure the tester is connected correctly. If no flow is indicated on the tester, the hoses are connected wrong. With the hoses connected correctly, increase the engine speed to full rpm*.

Warm the fluid to 60°C (140°F) by turning the restrictor control on the tester to about 6895 kPa (69 bar) (1000 psi). DO NOT exceed system relief pressure. Open the restrictor control and record the free flow (U.S. gpm) at full rpm*.

On the Remote Start Tool engage the auxiliary hydraulics, the light will come ON. Pull the trigger on the right handle or joystick for fluid flow to the quick coupler (fluid pressure will go over main relief). Record the highest pressure (psi) and flow (gpm). The high pressure flow must be at least 80% of free flow.

$$\% = \frac{\text{HIGH PRESSURE FLOW (U.S. gpm)}}{\text{FREE FLOW (U.S. gpm)}} \times 100$$

A low percentage may indicate a failed pump.

*Refer to (See Hydraulic System Specifications on Page SPEC-10-5.) for system relief pressure and full rpm.

HYDRAULIC PUMP (HIGH FLOW)

Description

The hydraulic pump is attached to the end of the hydrostatic pumps and is located in the center of the loader below the cab.

The hydraulic gear pump is a combination of gear pumps that provide hydraulic flow to several hydraulic systems.

The hydraulic gear pump has a dedicated charge pump. This supplies flow to the hydraulic fan motor and charge pressure to the hydrostatic pump.

Figure 20-61-1

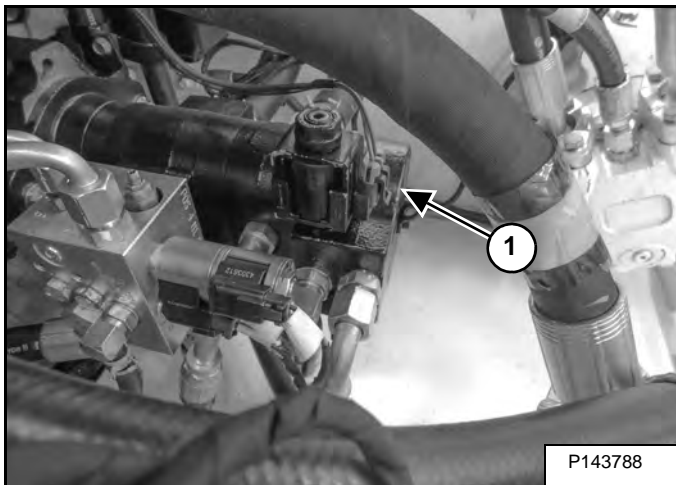

The high flow hydraulic pump (Item 1) **[Figure 20-61-1]** has an additional pump section that provides an additional amount of flow that is controlled by an external valve. The valve is switched from a button on the panel in the cab.

A seal kit is available to service the hydraulic pump. If any of the main components of the pump are damaged, the entire pump must be replaced.

HYDRAULIC PUMP (HIGH FLOW) (CONT'D)

Removal And Installation

! WARNING

Never work on a machine with the lift arms up unless the lift arms are secured by an approved lift arm support device. Failure to use an approved lift arm support device can allow the lift arms or attachment to fall and cause injury or death.

W-2059-0598

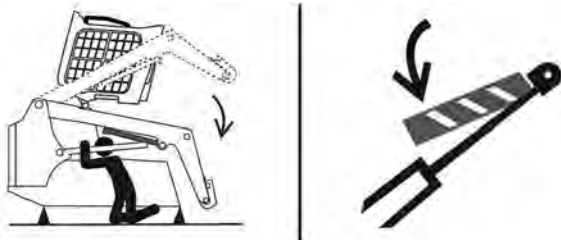

P-90328

AVOID DEATH

- Disconnecting or loosening any hydraulic tubeline, hose, fitting, component or a part failure can cause lift arms to drop.
- Keep out of this area when lift arms are raised unless supported by an approved lift arm support. Replace if damaged.

D-1009-0409

IMPORTANT

When repairing hydrostatic and hydraulic systems, clean the work area before disassembly and keep all parts clean. Always use caps and plugs on hoses, tubelines and ports to keep dirt out. Dirt can quickly damage the system.

I-2003-0888

Lift and block the rear of the loader. (See Procedure on Page 10-10-1.)

Raise the lift arms and install an approved lift arm support device. (See Installing Lift Arm Support Device on Page 10-20-1.)

Raise the operator cab. (See Raising Operator Cab on Page 10-30-2.)

Drain the hydraulic fluid from the reservoir. (See Replacing Hydraulic Fluid on Page 10-120-3.)

Remove the Power Bob-Tach block (if equipped). (See Removal And Installation on Page 20-120-4.)

NOTE: Mark all tubelines, hoses, and electrical connections for correct installation.

NOTE: Cap and plug all hydraulic connection points when tubelines or hoses are removed.

Figure 20-61-18

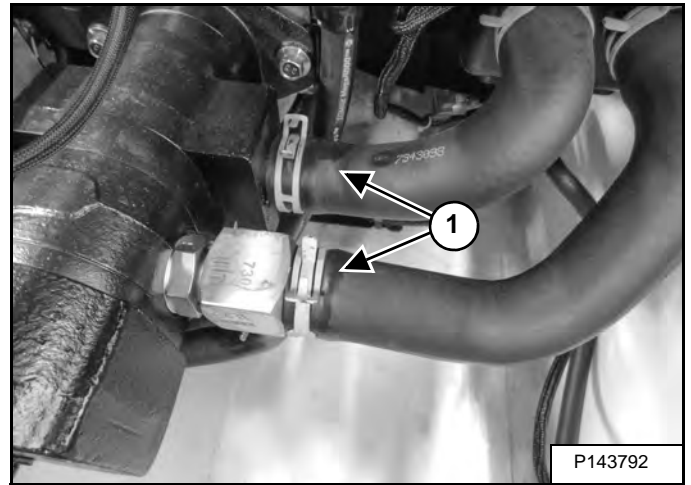

P143792

Disconnect and cap the inlet hoses (Item 1) [Figure 20-61-18].

Figure 20-61-19

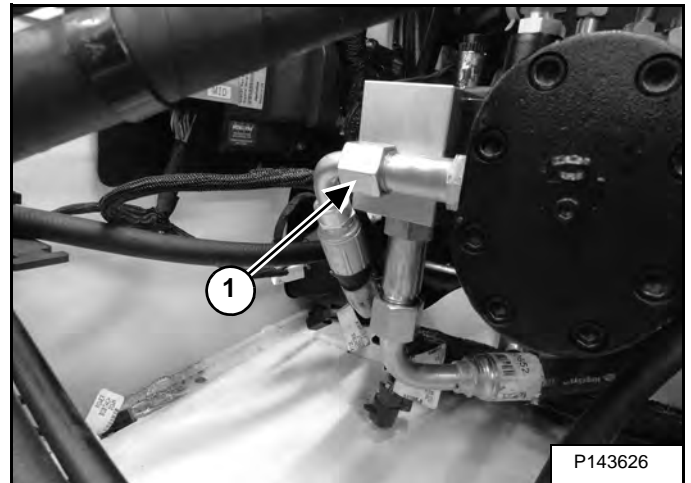

P143626

Remove the hose (Item 1) [Figure 20-61-19].

HYDRAULIC FLUID RESERVOIR (CONT'D)

Removal And Installation (Cont'd)

Figure 20-80-4

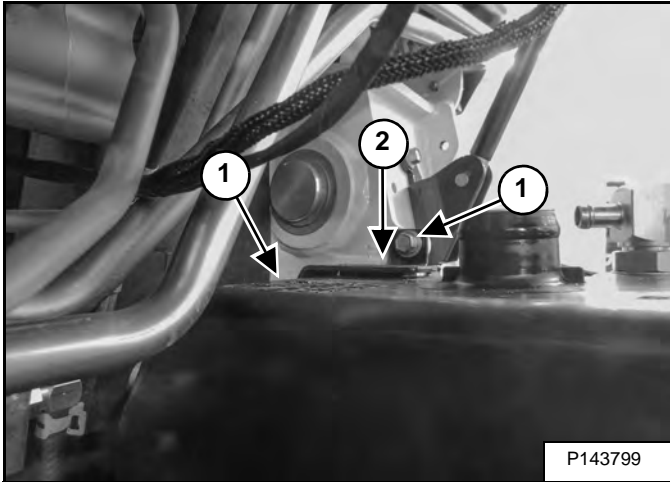

Remove the two bolts (Item 1) and bracket (Item 2) [Figure 20-80-4].

Figure 20-80-5

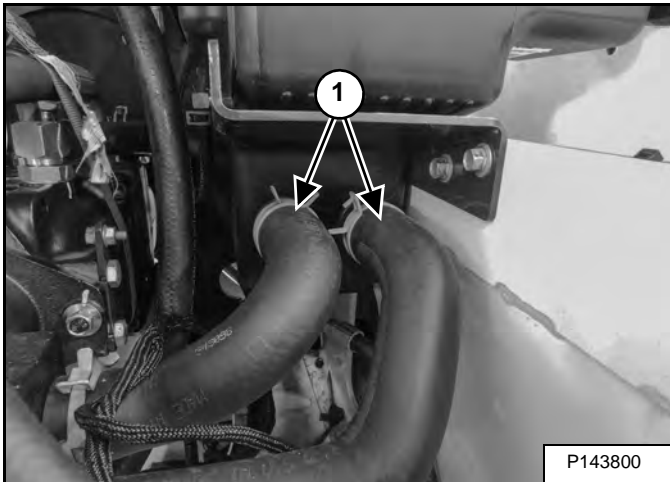

Remove the two hoses (Item 1) [Figure 20-80-5].

Figure 20-80-6

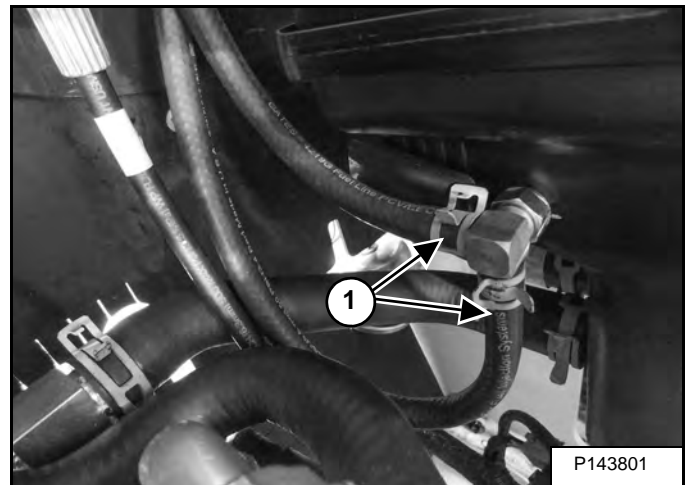

Remove the two hoses (Item 1) [Figure 20-80-6].

Figure 20-80-7

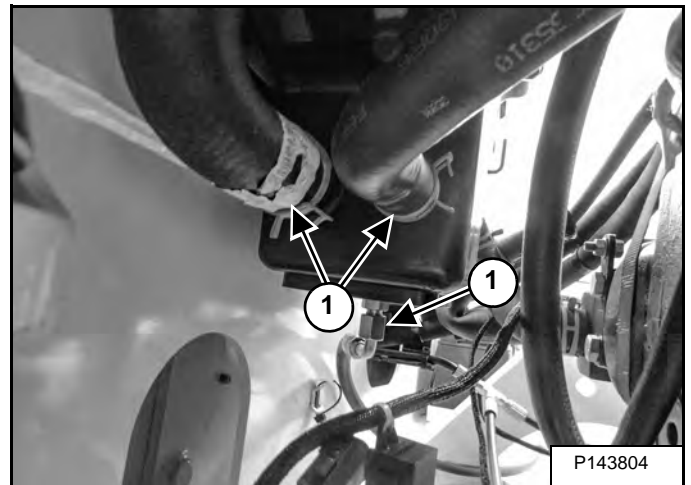

Remove the three hoses (Item 1) [Figure 20-80-7].

NOTE: Photo taken with engine removed for photo clarity.

BOB-TACH (POWER) BLOCK (CONT'D)

Testing Relief Valve (Cont'd)

Figure 20-120-3

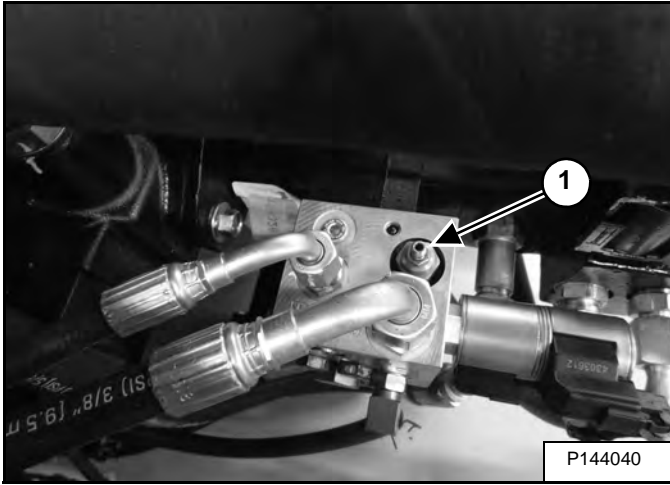
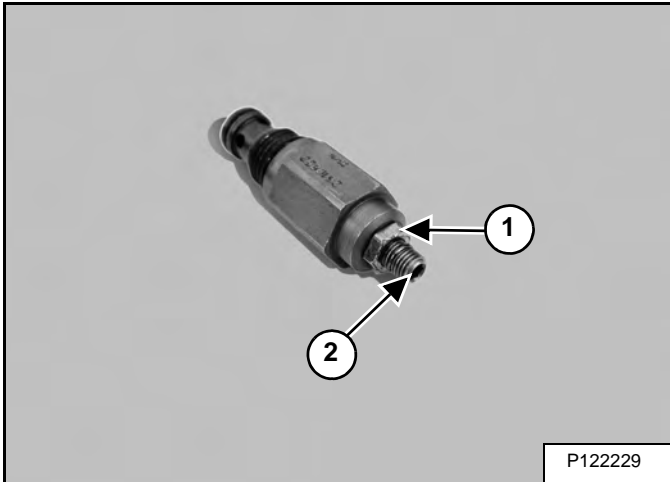

Figure 20-120-4



NOTE: Relief valve (Item 1) [Figure 20-120-3] removed from block for photo clarity.

If adjustment is required loosen the locknut (Item 1) and turn the adjusting screw (Item 2) [Figure 20-120-4] clockwise to increase pressure or counterclockwise to decrease pressure.

Test the relief valve setting after adjustment has been made.

FRONT AUXILIARY HYDRAULIC COUPLER BLOCK (CONT'D)

Disassembly And Assembly (Cont'd)

Figure 20-130-5

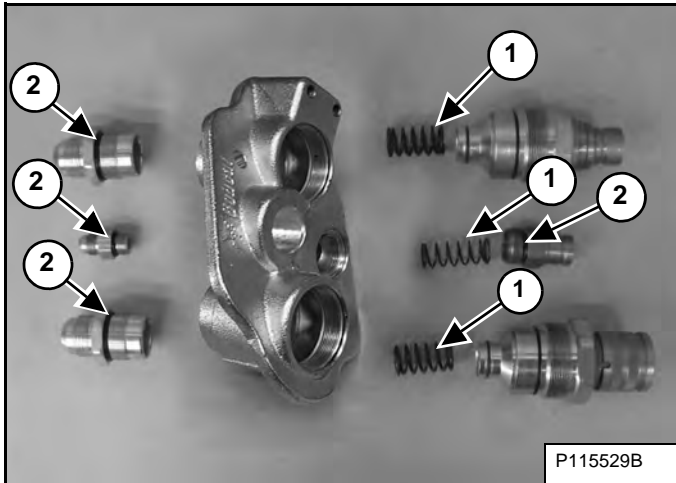

Remove the springs (Item 1) [Figure 20-130-5].

Remove the O-rings (Item 2) [Figure 20-130-5] from the fittings.

Figure 20-130-6

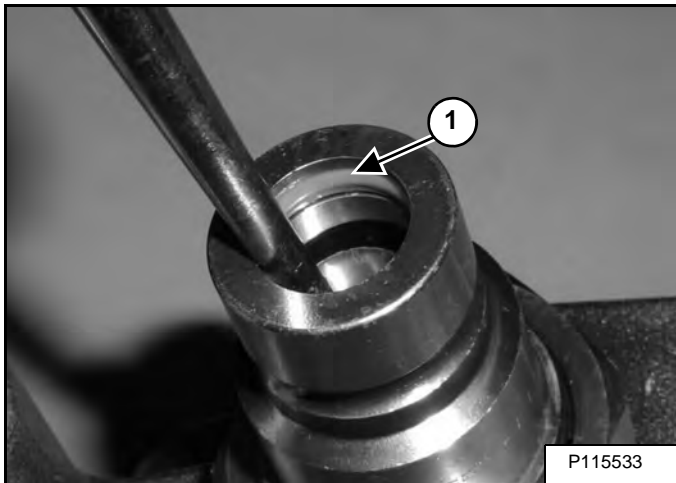

Press center of the male coupler down and replace the seal (Item 1) [Figure 20-130-6].

Figure 20-130-7

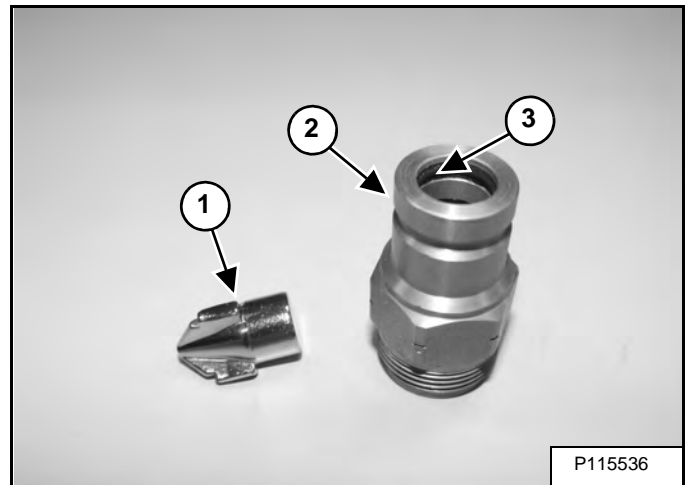

Remove the pintle (Item 1) from the case drain coupler (Item 2) [Figure 20-130-7].

Inspect the pintle (Item 1), the case drain coupler (Item 2) and the seal (Item 3) [Figure 20-130-7].

Replace the case drain coupler (Item 2) [Figure 20-130-7] as an assembly if any part is damaged.

Figure 20-130-8

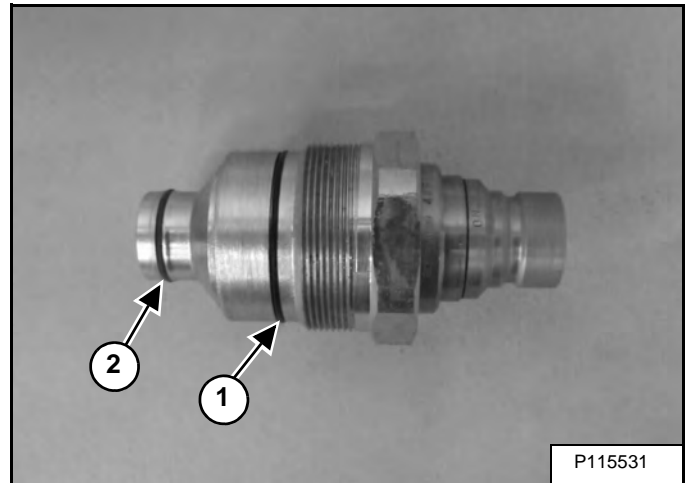

Inspect the O-ring (Item 1) and seal (Item 2) [Figure 20-130-8] and replace coupler if damaged.

HYDROSTATIC SYSTEM

HYDROSTATIC SYSTEM INFORMATION	30-10-1
Troubleshooting	30-10-1
HYDROSTATIC DRIVE MOTOR	30-20-1
Description	30-20-1
Removal And Installation	30-20-2
Parts Identification	30-20-5
Disassembly And Assembly	30-20-6
HYDROSTATIC DRIVE MOTOR (TWO-SPEED)	30-21-1
Description	30-21-1
Removal And Installation	30-21-2
Parts Identification	30-21-5
Disassembly And Assembly	30-21-6
HYDROSTATIC MOTOR CARRIER	30-30-1
Description	30-30-1
Removal And Installation	30-30-2
Disassembly	30-30-4
Assembly	30-30-6
CHARGE PRESSURE	30-40-1
Description	30-40-1
Testing	30-40-1
Sender Removal And Installation	30-40-2
HYDROSTATIC PUMP	30-50-1
Description	30-50-1
Port Locations And Gauge Installation	30-50-2
Removal And Installation	30-50-3
Hydrostatic Pump Startup	30-50-6
Parts Identification	30-50-7
Parts Identification (SJC)	30-50-9
High Pressure Relief And Bypass Valve	30-50-10
Charge Pressure Relief Valve	30-50-11
Disassembly And Assembly	30-50-12
Mechanical Neutral Adjustment	30-50-24
Hydraulic Controller Neutral Adjustment	30-50-26
TWO-SPEED VALVE	30-60-1
Description	30-60-1
Valve Block Removal And Installation	30-60-2
Valve Block Disassembly And Assembly	30-60-4
DRAIN MANIFOLD	30-70-1
Description	30-70-1
Drain Manifold Housing Removal And Installation	30-70-1

HYDROSTATIC DRIVE MOTOR (CONT'D)

Disassembly And Assembly (Cont'd)

Figure 30-20-12

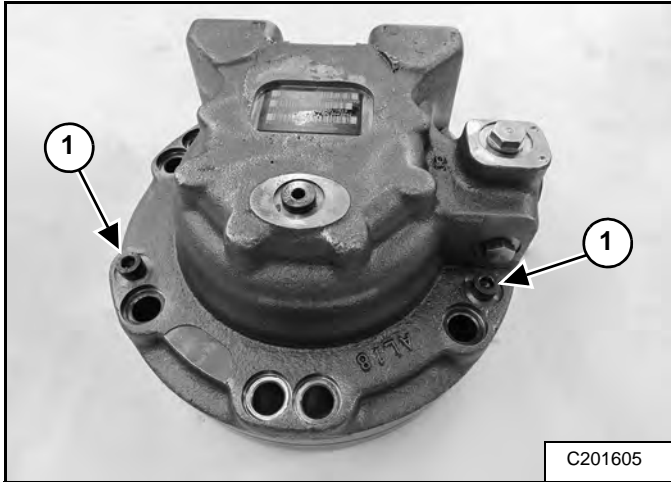

Remove the two cam ring mounting bolts (Item 1) [Figure 30-20-12].

Figure 30-20-13

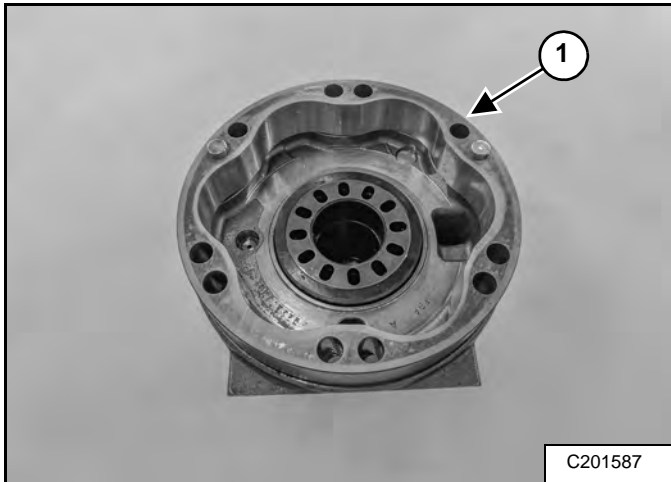

Remove the cam ring (Item 1) [Figure 30-20-13] from the motor housing.

Inspect the cam ring for surface scratches or wear.

Assembly: Install the cam ring (Item 1) [Figure 30-20-13] and align the mounting bolt holes.

Assembly: Install the two cam ring mounting bolts (Item 1) [Figure 30-20-12] and tighten to 67,8 N•m (50 ft-lb) torque.

Figure 30-20-14

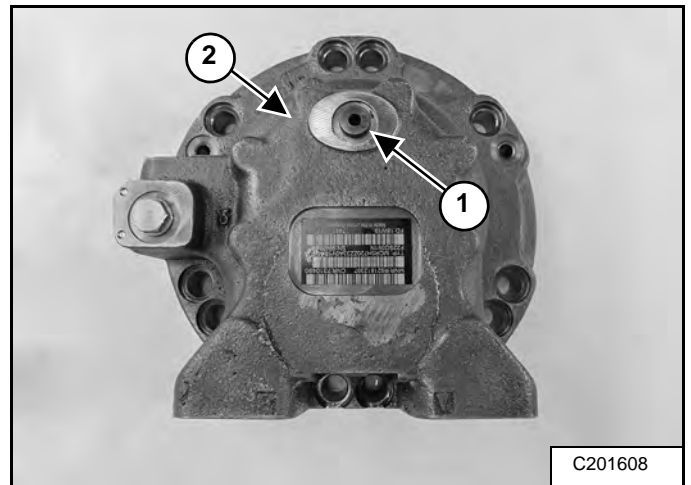

Remove the stop pin (Item 1) from the rear motor housing (Item 2) [Figure 30-20-14].

Assembly: Install the stop pin (Item 1) and tighten to 10 - 12 N•m (7 - 9 ft-lb) torque.

Figure 30-20-15

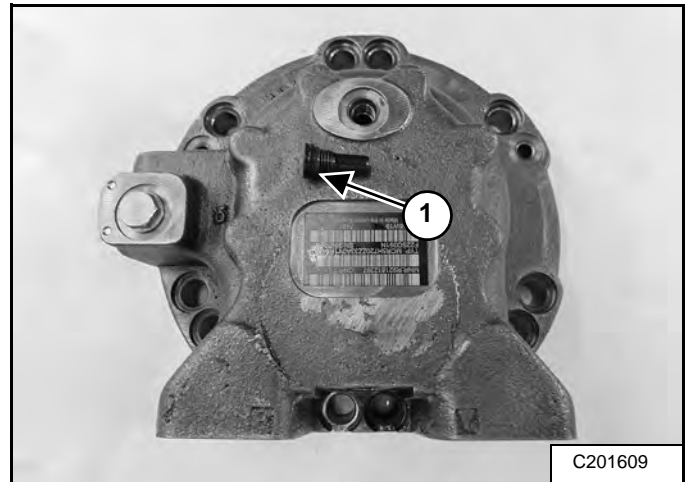

Remove the O-ring (Item 1) [Figure 30-20-15] from the stop pin.

HYDROSTATIC DRIVE MOTOR (TWO-SPEED) (CONT'D)

Disassembly And Assembly (Cont'd)

Figure 30-21-13

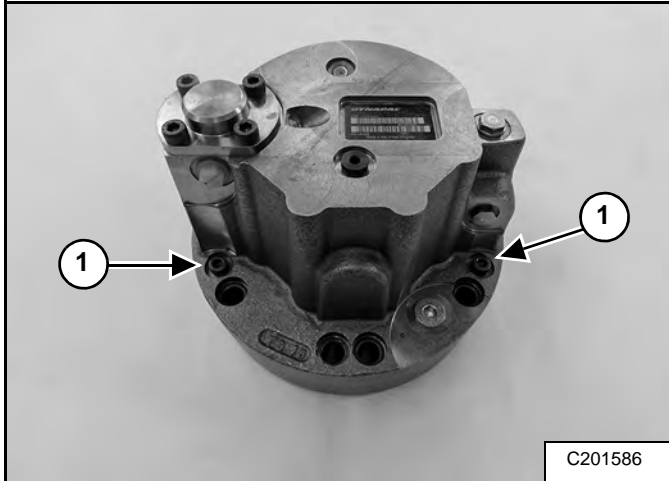

Remove the two cam ring mounting bolts (Item 1) [Figure 30-21-13].

Figure 30-21-14

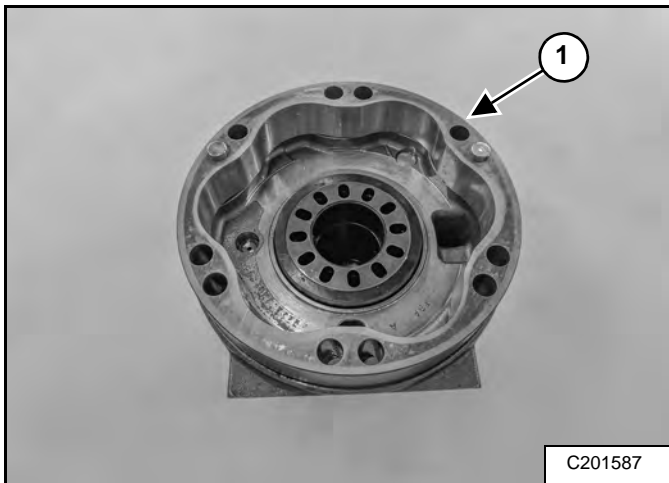

Remove the cam ring (Item 1) [Figure 30-21-14] from the motor housing.

Inspect the cam ring for surface scratches or wear.

Assembly: Install the cam ring (Item 1) [Figure 30-21-14] and align the mounting bolt holes.

Assembly: Install the two cam ring mounting bolts (Item 1) [Figure 30-21-13] and tighten to 67,8 N•m (50 ft-lb) torque.

Figure 30-21-15

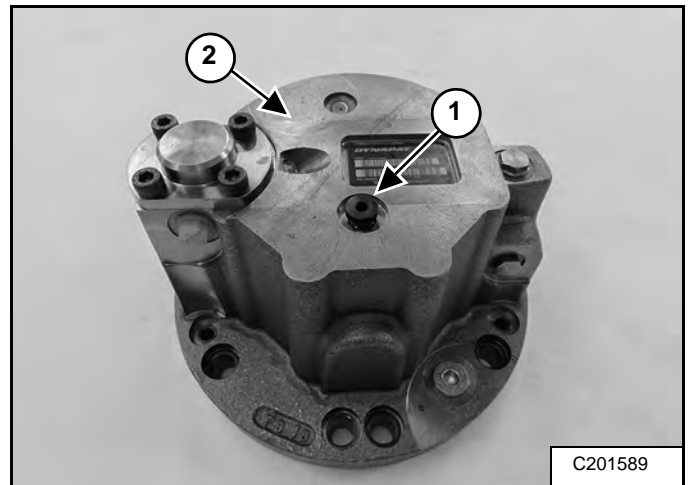

Remove the stop pin (Item 1) from the rear motor housing (Item 2) [Figure 30-21-15].

Assembly: Install the stop pin (Item 1) and tighten to 10 - 12 N•m (7 - 9 ft-lb) torque.

Figure 30-21-16

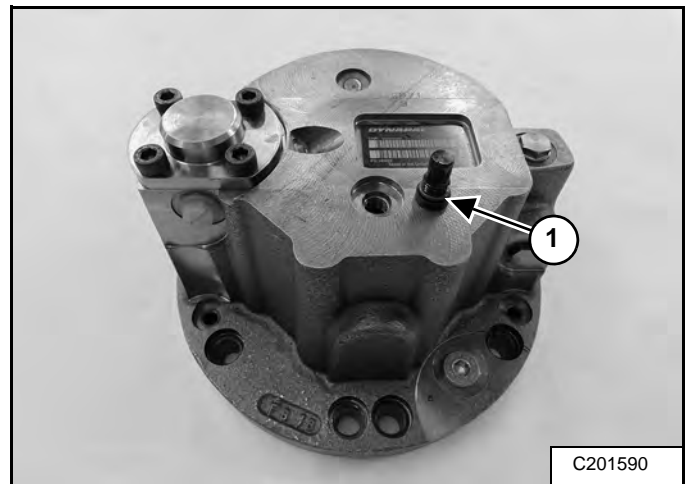

Remove the O-ring (Item 1) [Figure 30-21-15] from the stop pin.

CHARGE PRESSURE

Description

Charge pressure is a supply of fluid to the hydrostatic pumps. Charge pressure is regulated by a charge relief valve located inside the hydrostatic pump. Charge pressure is used to replenish hydrostatic fluid removed from the drive circuit, pump and motor “internal leakage” and from the hydrostatic motors shuttle (flushing) valve.

Charge pressure is also used to operate other hydraulic functions, such as shifting the auxiliary spool, and to pilot open the BICS™ system for the lift and tilt in the main hydraulic control valve.

The charge pressure sender is located on the hydraulic fan motor. Charge pressure alarm settings are pre-programmed into the main controller and are based on loader type and options installed.

Testing

Figure 30-40-1

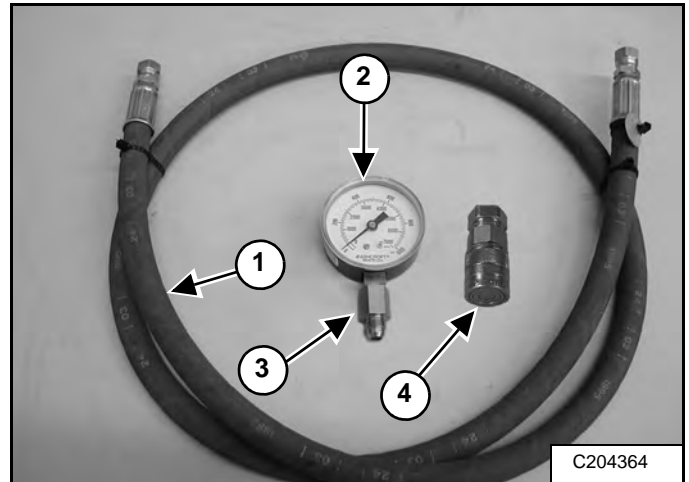

The tools needed to test charge pressure, hydraulic hose (Item 1), hydraulic gauge 6895 kPa (69,0 bar) (1000 psi) (Item 2), adapter fitting (Item 3), coupler (Item 4) [Figure 30-40-1] and 7217666 Remote Start Tool Kit.

Figure 30-40-2

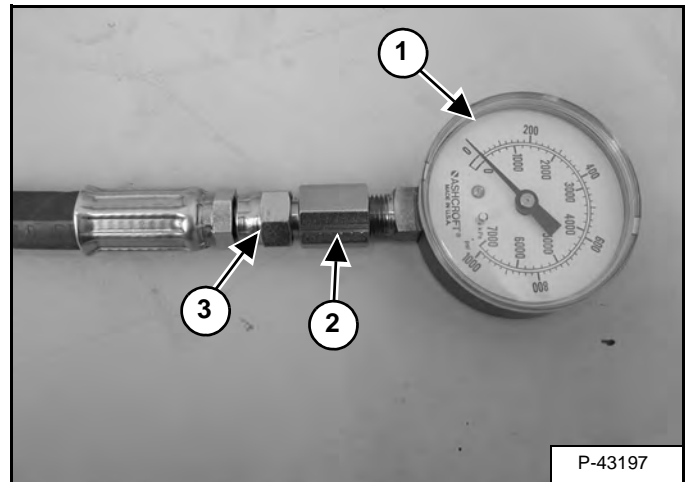

Connect the gauge (Item 1) to the adapter fitting (Item 2) [Figure 30-40-2].

Connect the hydraulic hose (Item 3) [Figure 30-40-2] to the adapter fitting. Tighten all connections.

HYDROSTATIC PUMP (CONT'D)

Parts Identification

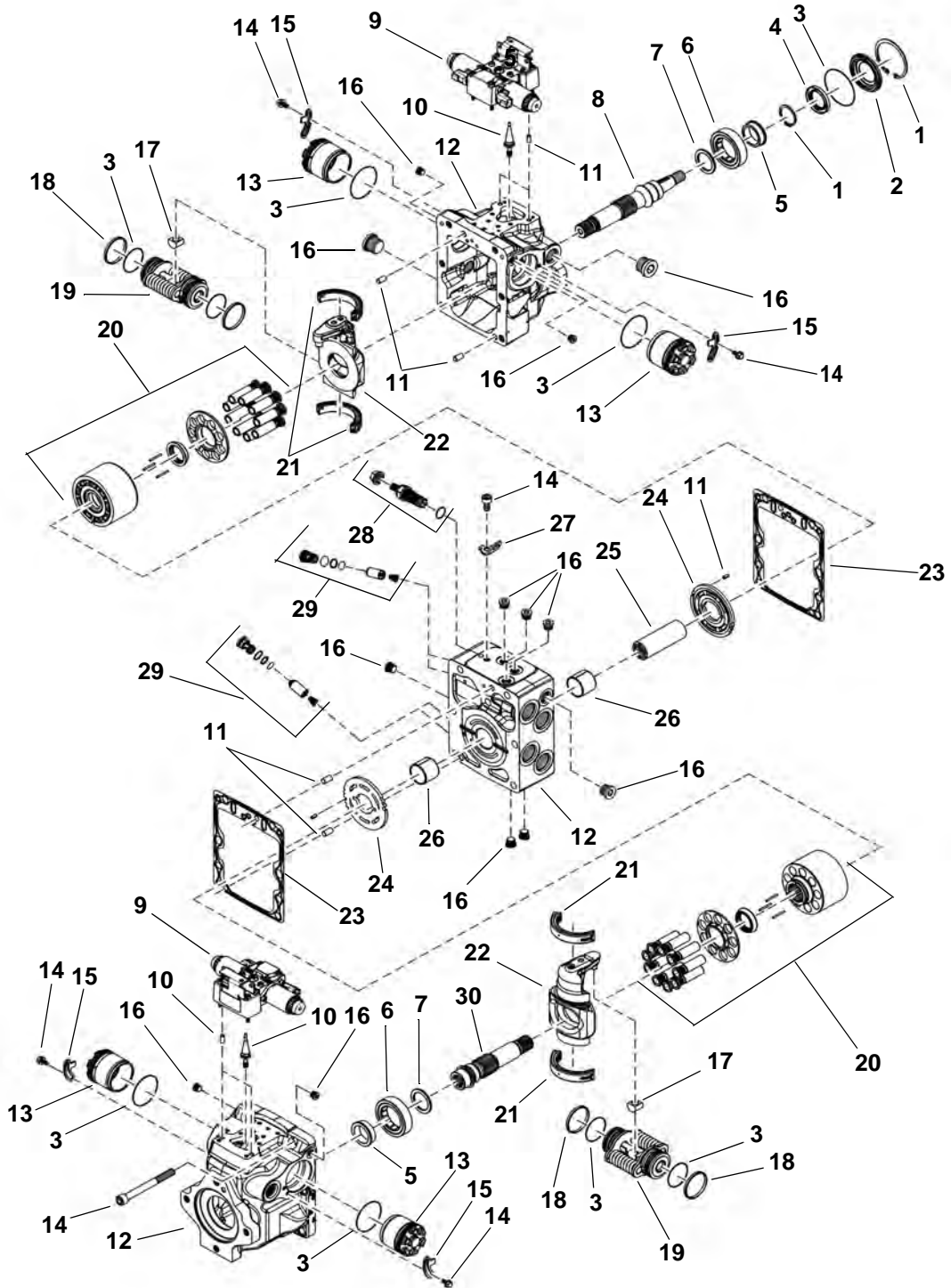

NA14930S

HYDROSTATIC PUMP (CONT'D)

Disassembly And Assembly (Cont'd)

Figure 30-50-40

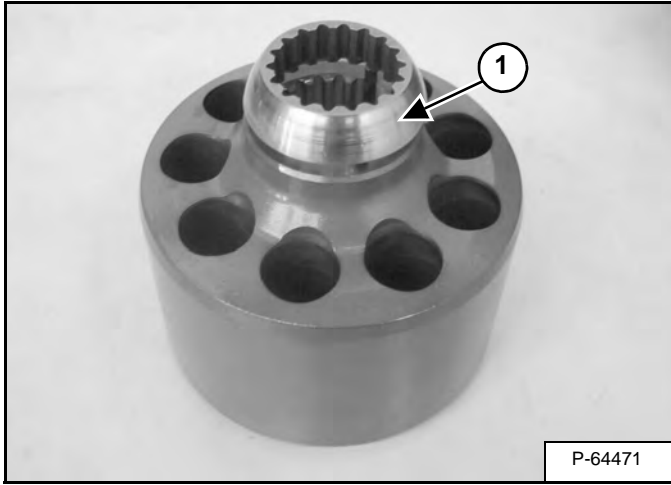

Remove the spherical washer (Item 1) [Figure 30-50-40].

Figure 30-50-41

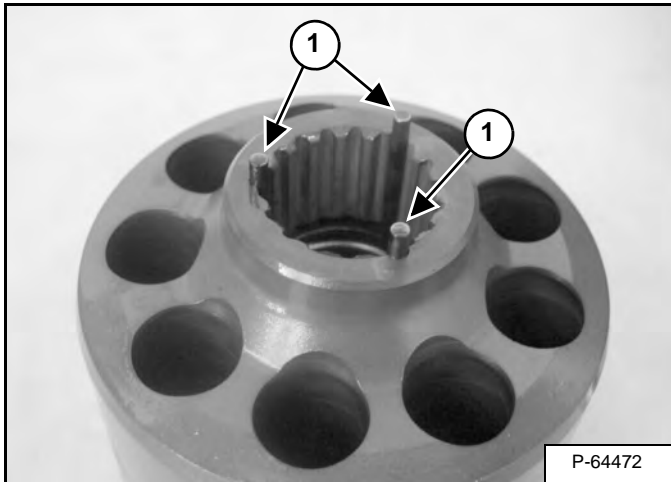

Inspect the pins (Item 1) [Figure 30-50-41]. They should be the same length. Do not remove.

Figure 30-50-42

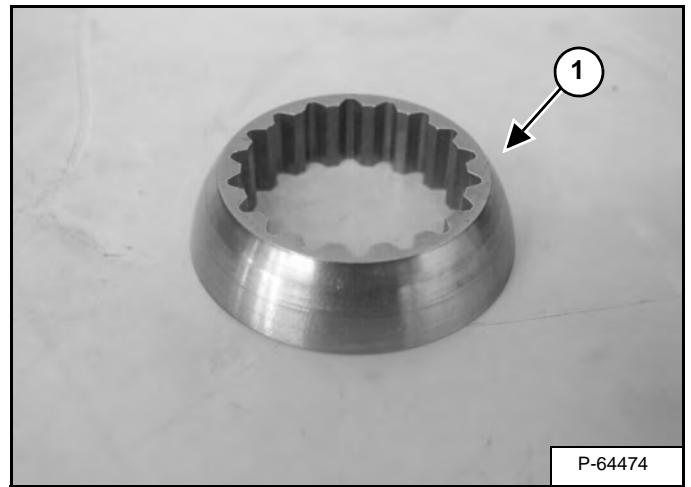

Inspect the spherical washer for scoring and wear (Item 1) [Figure 30-50-42].

Figure 30-50-43

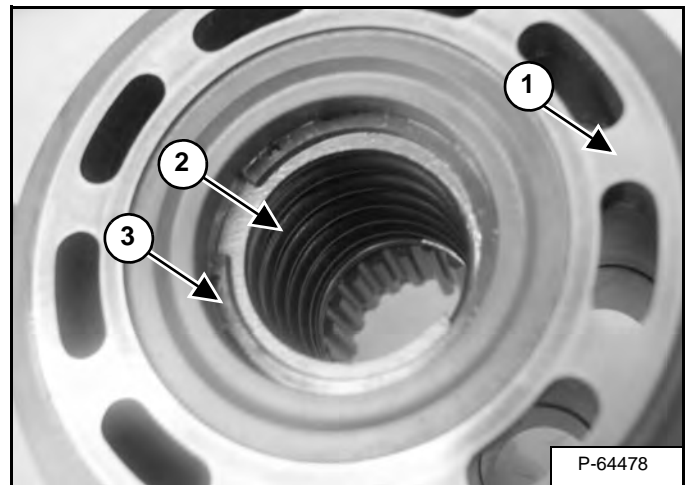

Inspect the back surface of the rotating block (Item 1) [Figure 30-50-43] where the valve plate seals. Ensure there is no scratches or scoring.

Visually ensure spring (Item 2) and c-clip (Item 3) [Figure 30-50-43] are not bent or damaged.

HYDROSTATIC PUMP (CONT'D)

Hydraulic Controller Neutral Adjustment (Cont'd)

Figure 30-50-68

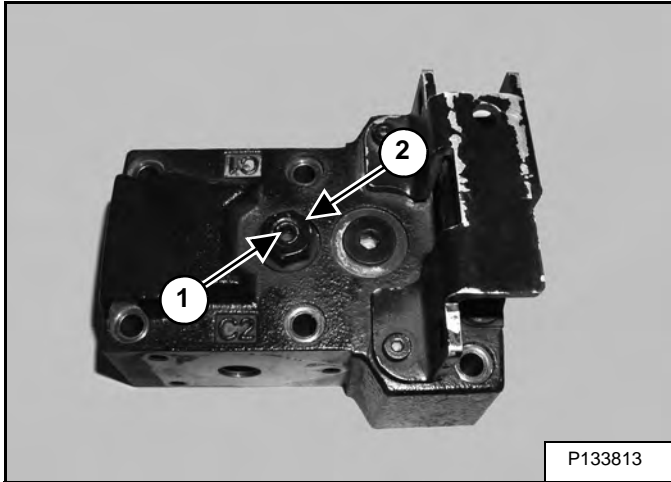

Hold the neutral adjusting screw (Item 1) stationary while loosening the locknut (Item 2) [Figure 30-50-68].

Observe pressure gauges. If necessary, turn adjusting screw to reduce any pressure differential. Adjustment of the EDC is very sensitive. Be sure to hold the hex wrench steady while loosening the locknut. Total adjustment is less than 120 degrees.

Rotate the neutral adjusting screw clockwise until the pressure increases on the gauge. Note the angular position of the wrench. Then rotate the neutral adjusting screw counterclockwise until the pressure increases by an equal amount on the other gauge. Again note the angular position of the wrench.

Rotate the neutral adjusting screw clockwise half the distance between the wrench positions noted above. The gauges should read the same pressure, indicating that the control is in its neutral position.

Figure 30-50-69

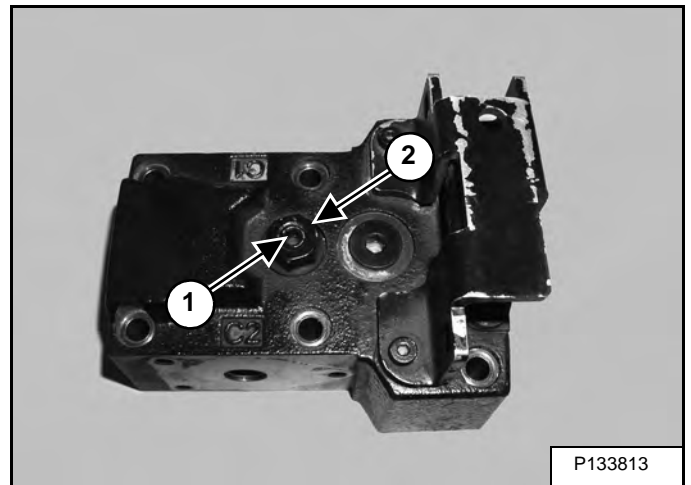

Hold the neutral adjusting screw (Item 1) stationary and tighten the locknut (Item 2) [Figure 30-50-69] to 10 N•m (7 ft-lb) torque. Do not over torque the nut.

When the neutral position is set, stop the engine, remove the gauges, and install the gauge port plugs. Reconnect the external control input. A small pressure differential of 2.5 bar (36 psi) or less is acceptable. Zero differential is usually not possible.

DRIVE SYSTEM

BRAKE	40-10-1
Description	40-10-1
Block Removal And Installation	40-10-1
DRIVE COMPONENTS	40-20-1
Description	40-20-1
Axle Seal Removal And Installation	40-20-2
Axle, Sprocket And Bearings Removal And Installation	40-20-4
Chain Removal And Installation	40-20-9
CHAINCASE	40-30-1
Description	40-30-1
Chaincase Cover Removal And Installation	40-30-1

DRIVE COMPONENTS (CONT'D)

Axle, Sprocket And Bearings Removal And Installation (Cont'd)

Figure 40-20-17

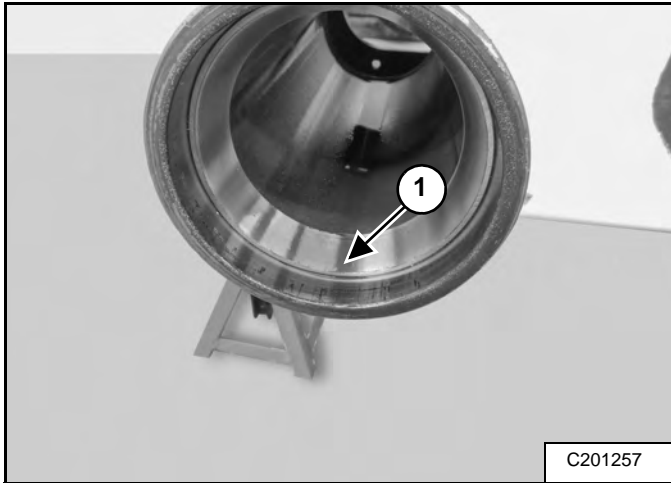

Inspect all races and bearings (Item 1) [Figure 40-20-17].

Figure 40-20-18

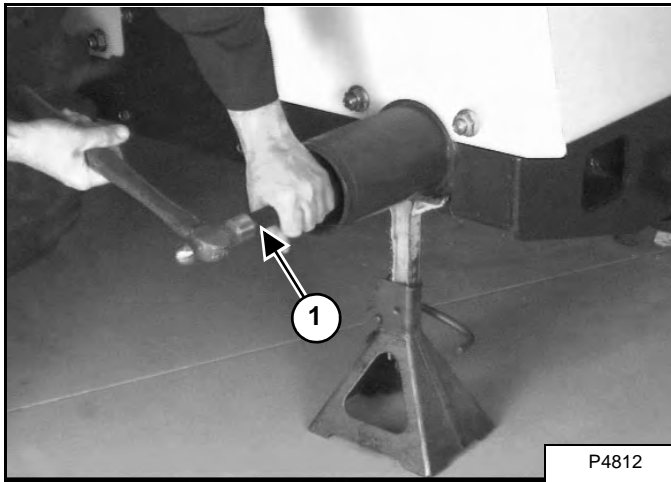

Use the tools provided in the MEL1202 Axle Bearing Service Set. A slide hammer is also needed.

NOTE: Some photos may appear different but the procedure is the same.

Use the long driver handle (Item 1) [Figure 40-20-18] and the bearing cup removal tool to remove the inner bearing cup.

Figure 40-20-19

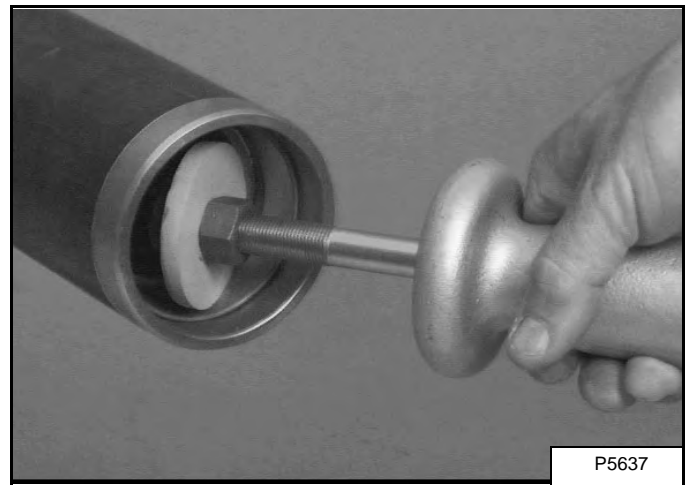

To remove the outer bearing, install a bearing cup removal tool on the slide hammer.

Install the slide hammer / tool assembly behind the bearing cup [Figure 40-20-19].

Figure 40-20-20

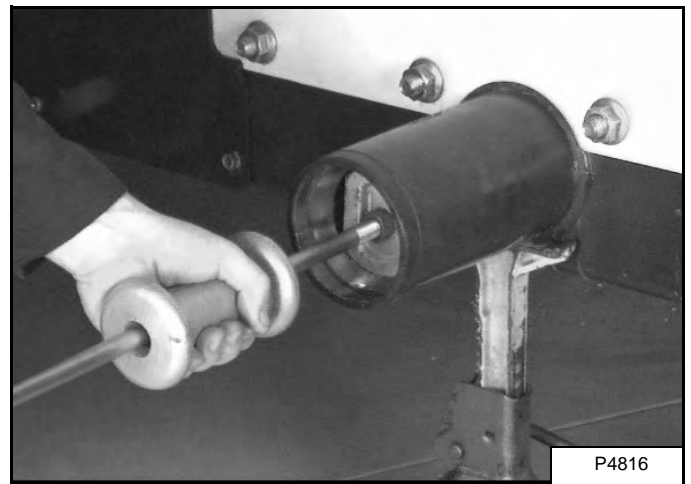

Use the slide hammer to remove the bearing cup from the axle tube [Figure 40-20-20].

SEAT BAR

Description

The seat bar is the secondary restraint system that has a sensor that automatically stops the loader functions until the seat bar is lowered.

Figure 50-10-1

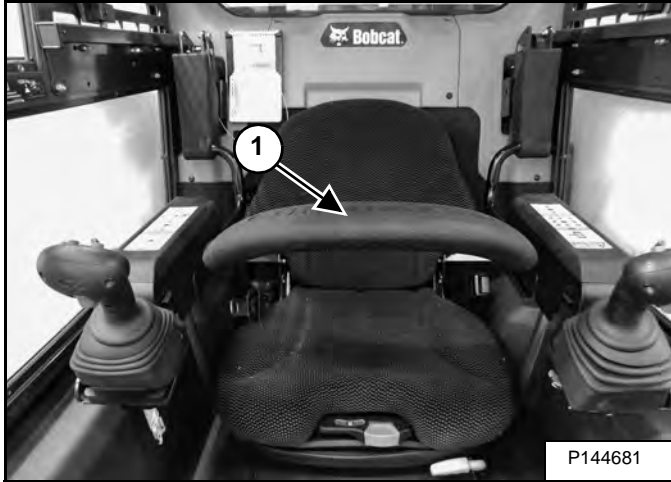

The seat bar is located in the operator cab (Item 1) [Figure 50-10-1].

OPERATOR SEAT (CONT'D)

Seat Belt Removal And Installation (Three Point) (Cont'd)

Figure 50-30-8

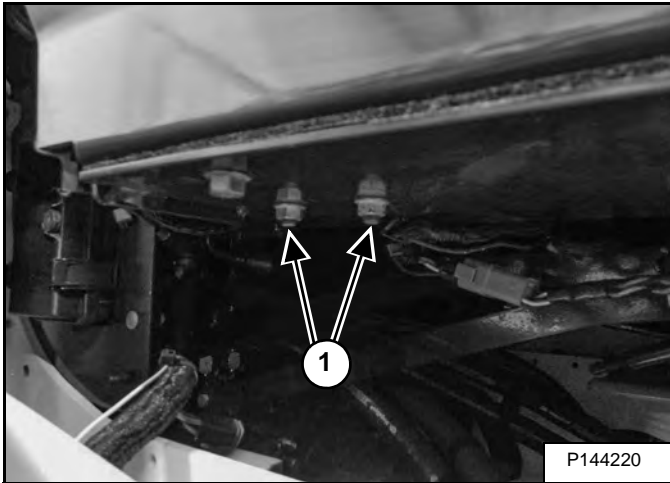

Remove the two nuts (Item 1) [Figure 50-30-8].

Figure 50-30-9

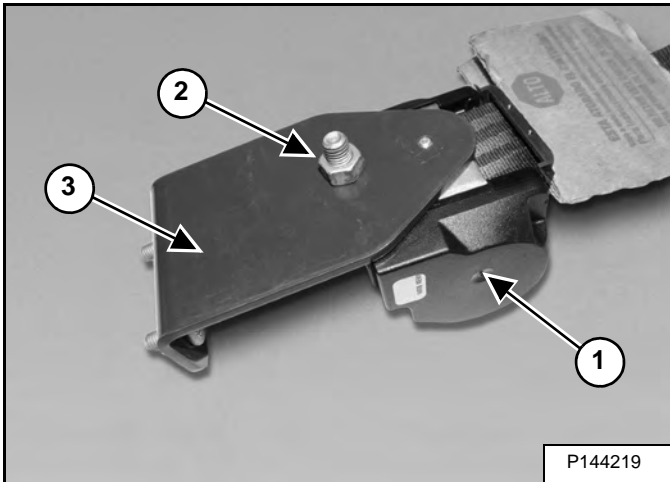

Remove the shoulder belt retractor (Item 1), remove the nut and bolt (Item 2), and bracket (Item 3) [Figure 50-30-9].

BOB-TACH (HAND LEVER) (CONT'D)

Removal And Installation (Cont'd)

Figure 50-40-5

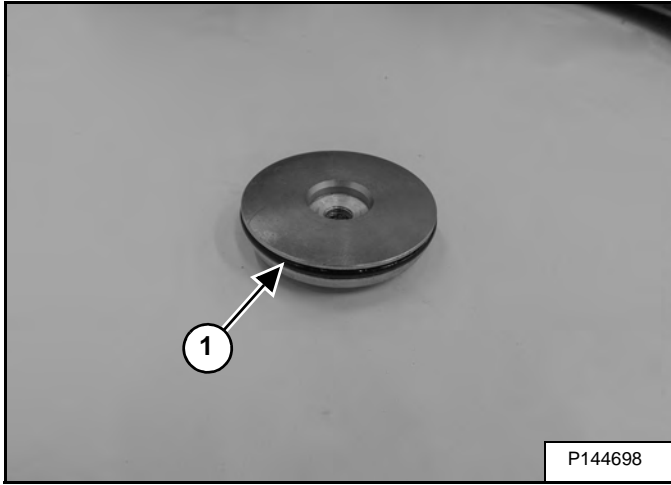

Replace the O-ring (Item 1) [Figure 50-40-5] on the grease plug.

Figure 50-40-6

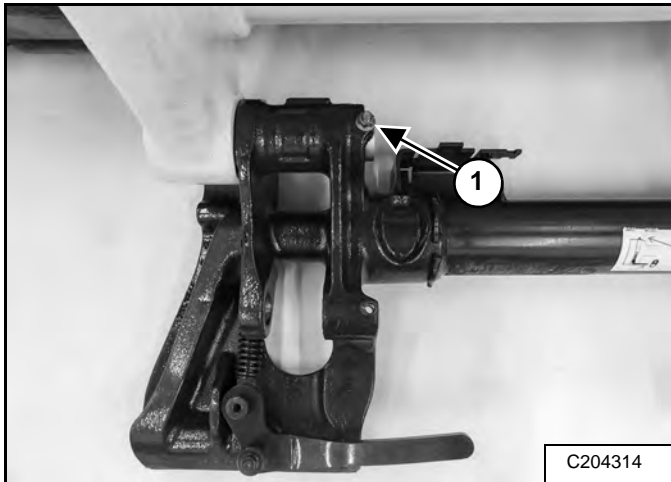

Remove the pivot pin retaining nut and bolt (Item 1) [Figure 50-40-6] from the Bob-Tach (both sides).

Figure 50-40-7

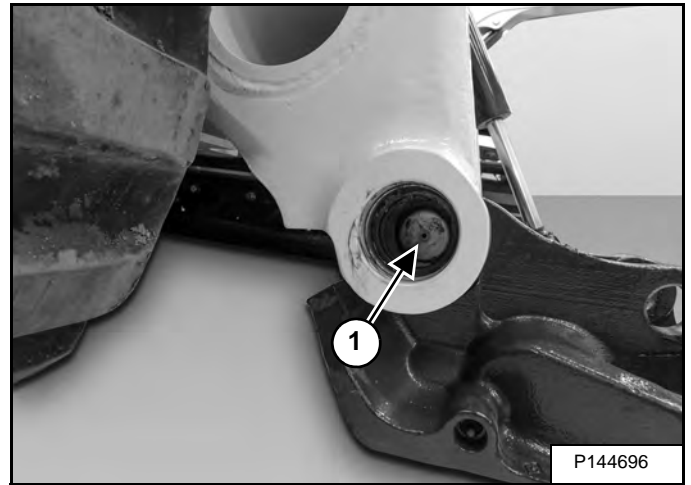

Drive the pivot pin (Item 1) [Figure 50-40-7] from the Bob-Tach (both sides).

Figure 50-40-8

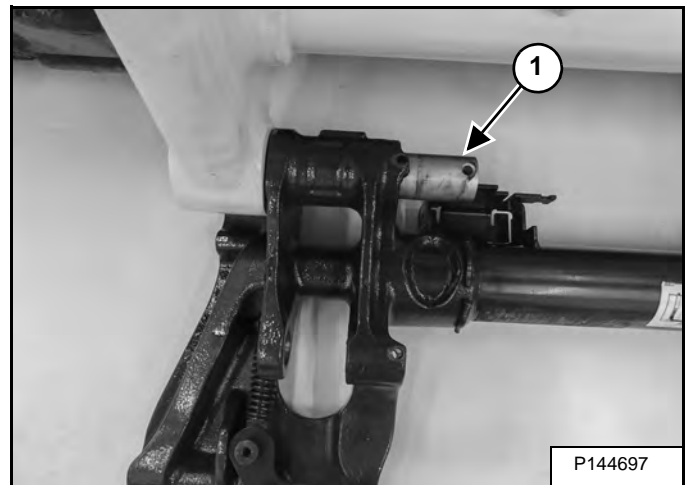

Remove the pivot pin (Item 1) [Figure 50-40-8].

NOTE: APPLY GREASE TO ALL FIXED HOUSING BORES BEFORE INSTALLING THE PIN.

LIFT ARMS

Driver Link Removal And Installation

Raise the lift arms and install an approved lift arm support device. (See Installing Lift Arm Support Device on Page 10-20-1.)

NOTE: Remove the lift arm driver link from one side of the loader at a time.

Figure 50-50-1

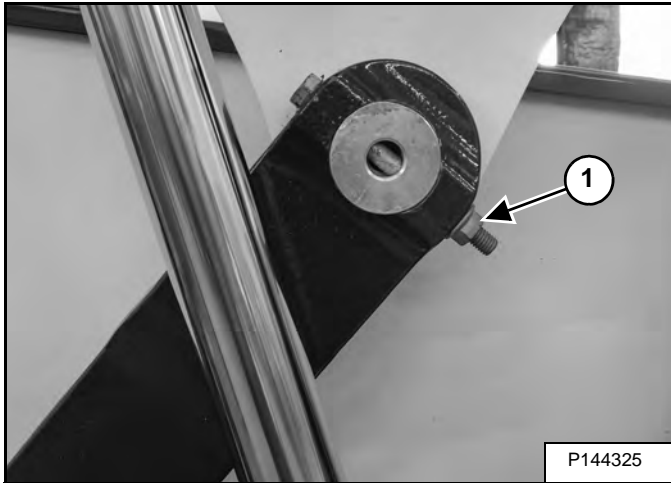

Remove the retainer nut and bolt (Item 1) [Figure 50-50-1].

Installation: Tighten the retainer nut and bolt to 48 - 54 N•m (35 - 40 ft-lb) torque.

Figure 50-50-2

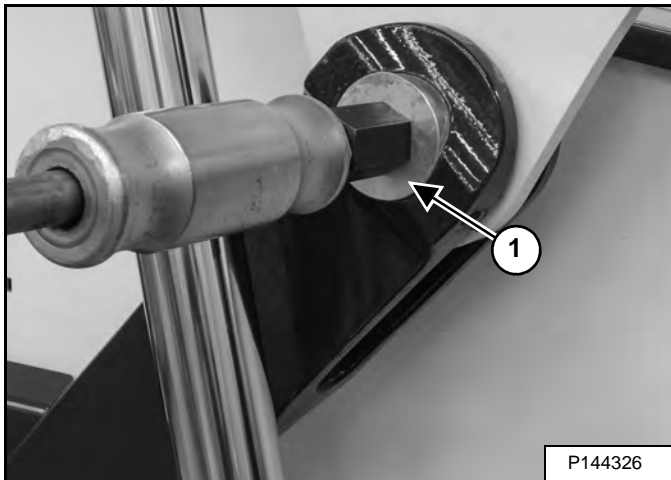

With a slide hammer, remove the pivot pin (Item 1) [Figure 50-50-2].

Figure 50-50-3

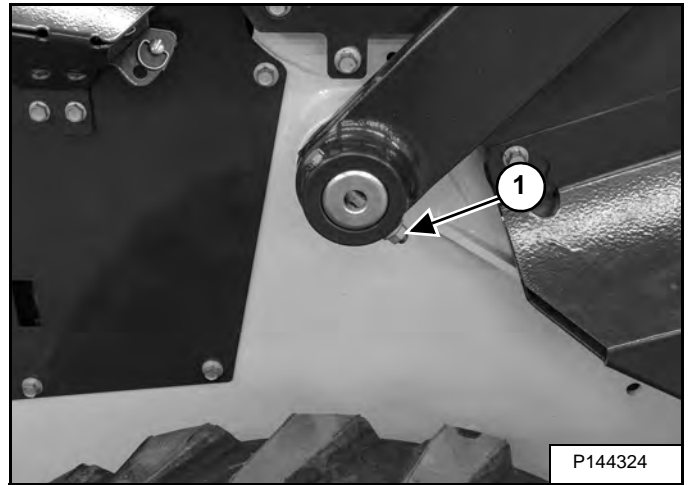

Remove the retainer nut and bolt (Item 1) [Figure 50-50-3].

Installation: Tighten the retainer nut and bolt to 48 - 54 N•m (35 - 40 ft-lb) torque.

NOTE: APPLY GREASE TO ALL FIXED HOUSING BORES BEFORE INSTALLING THE PIN.

Figure 50-50-4



Slide the driver link (Item 1) [Figure 50-50-4] from the loader pivot pin.

REAR DOOR (TAILGATE)

Removal And Installation

Figure 50-70-1

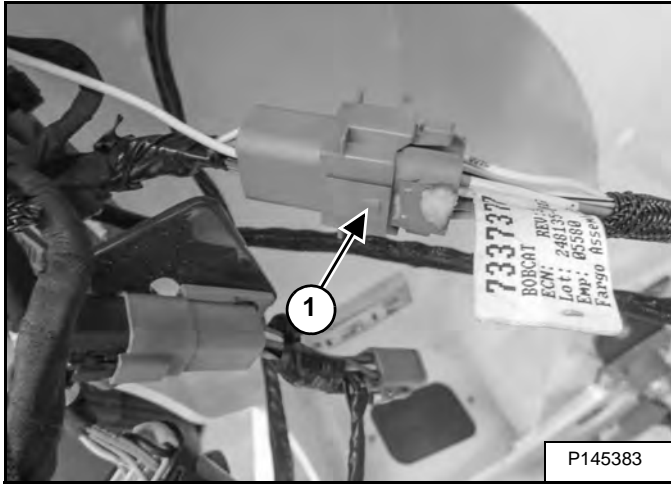

Disconnect the wire harness connector (Item 1) [Figure 50-70-1] from the main frame harness.

Remove both rear lights (Item 2) [Figure 50-70-1] from the door. (See Rear Removal And Installation on Page 60-60-1.)

Figure 50-70-2

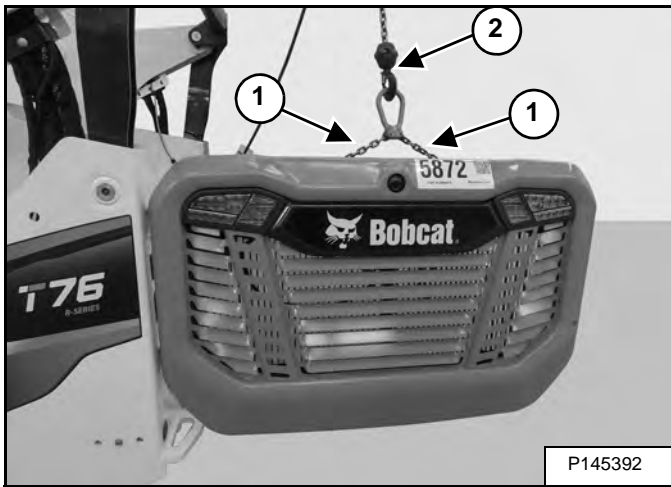

Secure the chain hooks (Item 1) [Figure 50-70-2] to the door.

Connect a lifting device (Item 2) [Figure 50-70-2] to the lifting chain.

Figure 50-70-3

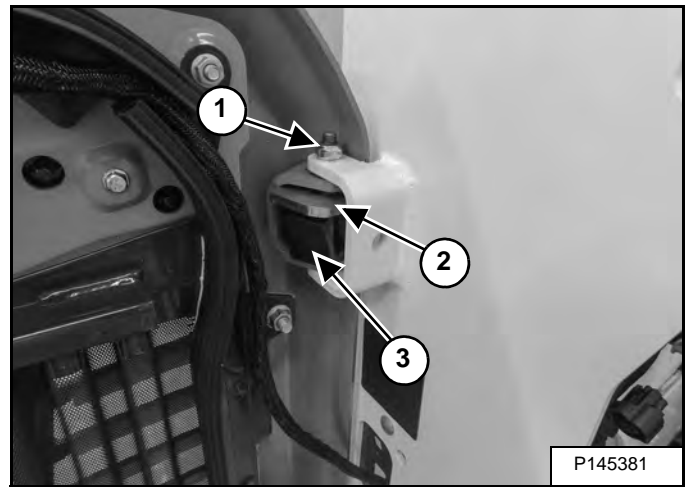

Remove the top and bottom door hinge mounting nuts and bolts (Item 1) [Figure 50-70-3].

NOTE: Install the door stop (Item 2) and the door stop retainer (Item 3) in the top hinge as shown [Figure 50-70-3].

Figure 50-70-4

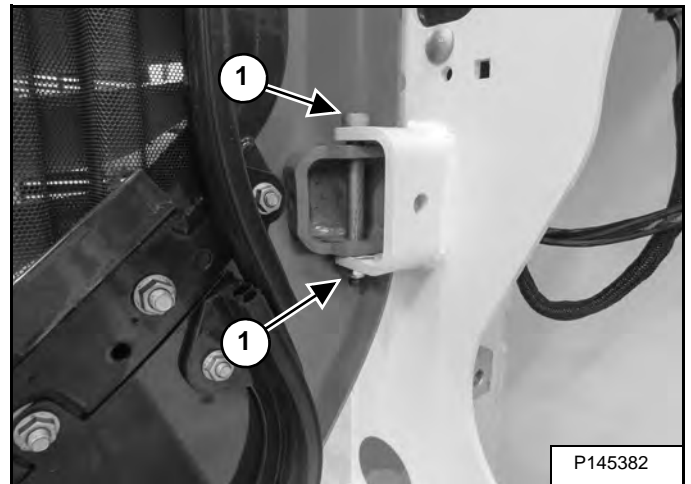

Remove the bottom door hinge mounting nut and bolt (Item 1) [Figure 50-70-4].

Installation: Tighten the mounting nuts and bolts to 34 - 38 N•m (25 - 28 ft-lb) torque.

Lift the door away from the loader frame and put the door flat on the floor.

FOOTREST (SJC)

Footrest Removal And Installation (Right Side)

Figure 50-91-1

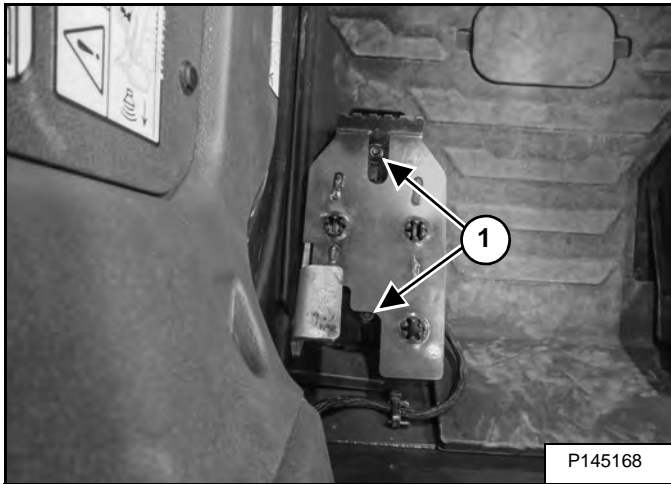

Remove the two nuts (Item 1) [Figure 50-91-1].

Figure 50-91-2

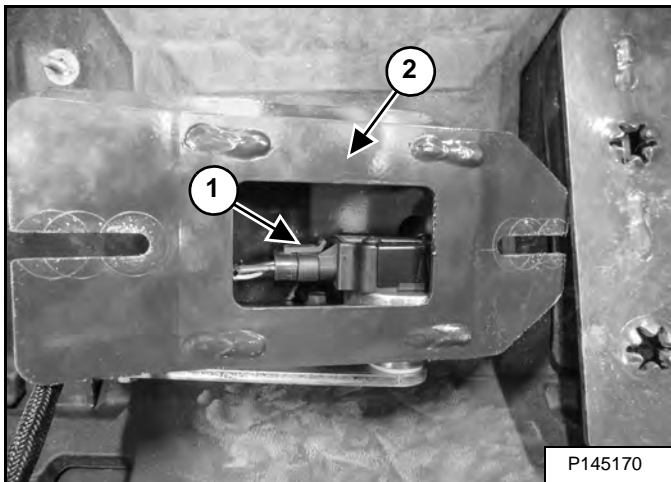

Disconnect the wire harness connector (Item 1) and remove the footrest assembly (Item 2) [Figure 50-91-2].

Footrest Removal And Installation (Left Side)

Figure 50-91-3

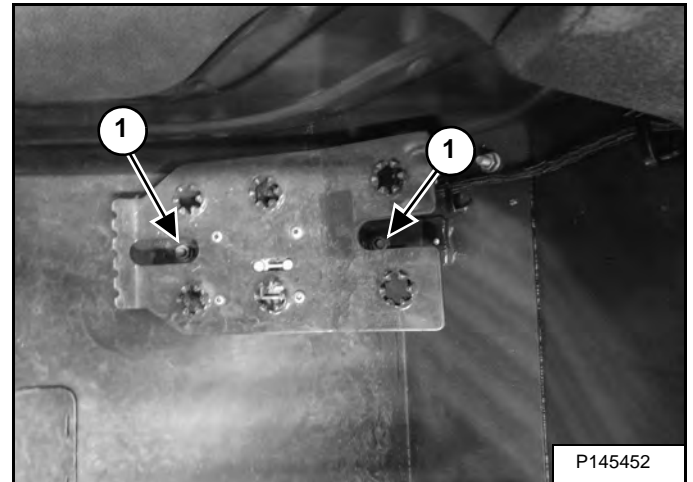

Remove the two nuts (Item 1) and the footrest assembly [Figure 50-91-3].

CONTROL HANDLE / LEVER (SJC)

Description

Figure 50-111-1

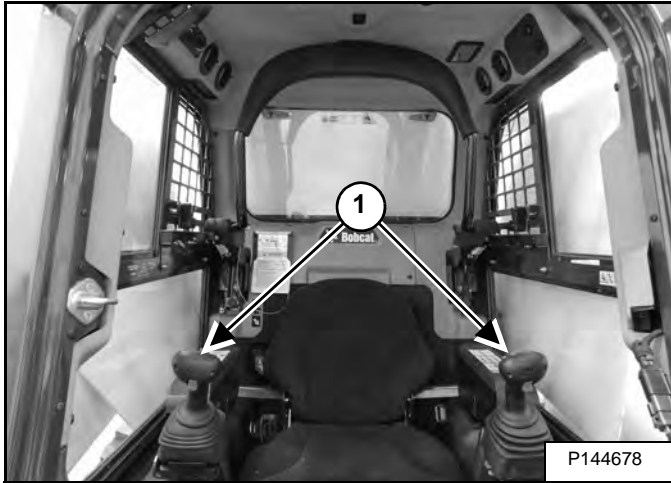

The loader has two electronic handles (Item 1) [Figure 50-111-1] that control the steering, lift, and tilt functions. There are no mechanical connections to the hydrostatic pumps or the control valve.

Joystick Testing

See Bobcat Advanced Troubleshooting System (B.A.T.S.) or connect to service analyzer to test function.

ACCESS PANELS (UPPER) (CONT'D)

Removal And Installation (Right Side)

Figure 50-121-5

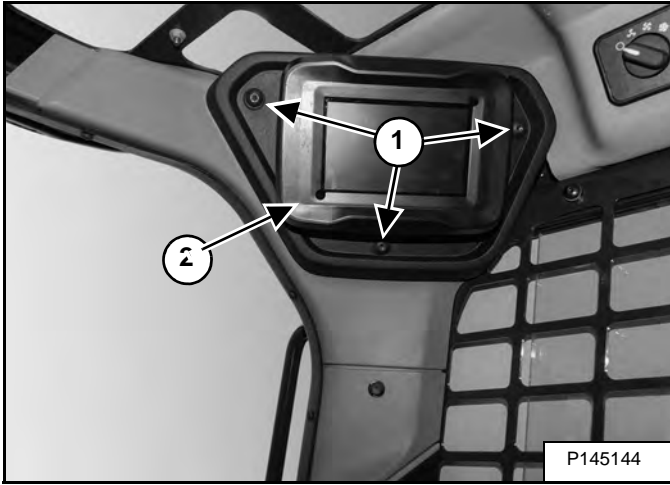

Remove the three screws (Item 1) and pull display (Item 2) out of upper right panel.

Figure 50-121-6

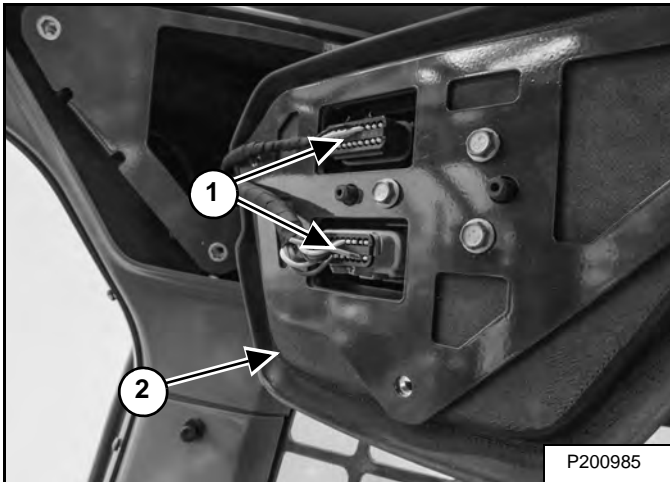

Disconnect the two wire harness connectors (Item 1) and remove the display (Item 2) [Figure 50-121-6].

Figure 50-121-7

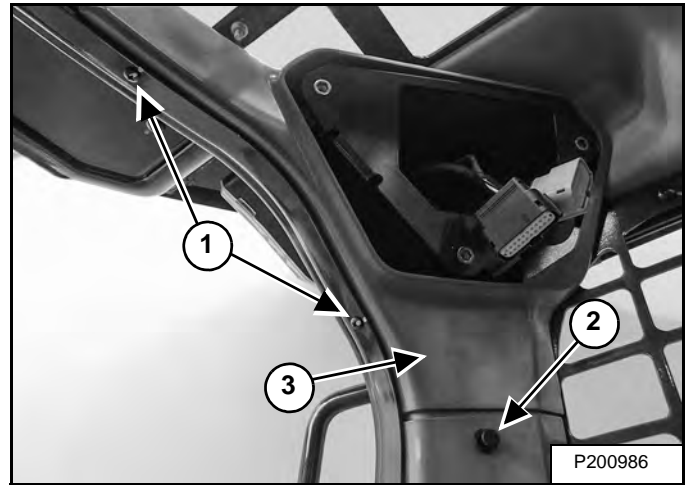

Remove the two screws (Item 1), fastener (Item 2), and remove the upper right panel (Item 3) [Figure 50-121-7].

CLICK HERE TO **DOWNLOAD** THE COMPLETE MANUAL

- Thank you very much for reading the preview of the manual.
- You can download the complete manual from: www.heydownloads.com by clicking the link below



- Please note: If there is no response to CLICKING the link, please download this PDF first and then click on it.

CLICK HERE TO **DOWNLOAD** THE COMPLETE MANUAL

WINDOW (SIDE)

Removal And Installation

Raise the lift arms and install an approved lift arm support device. (See Installing Lift Arm Support Device on Page 10-20-1.)

Figure 50-132-1

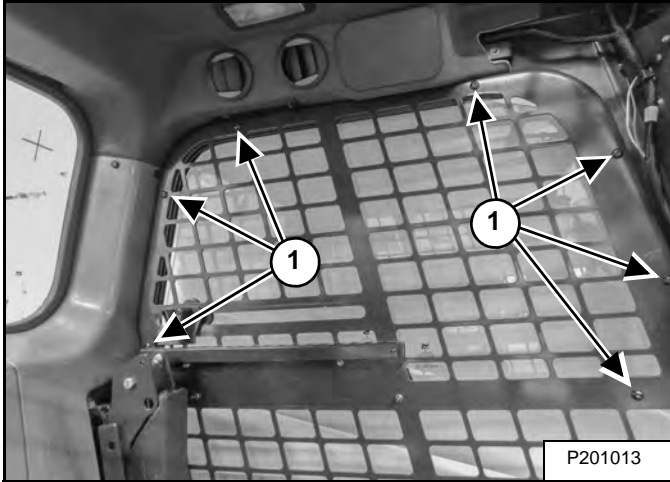

Remove the seven screws (Item 1) [Figure 50-132-1] from the side window assembly.

Figure 50-132-2

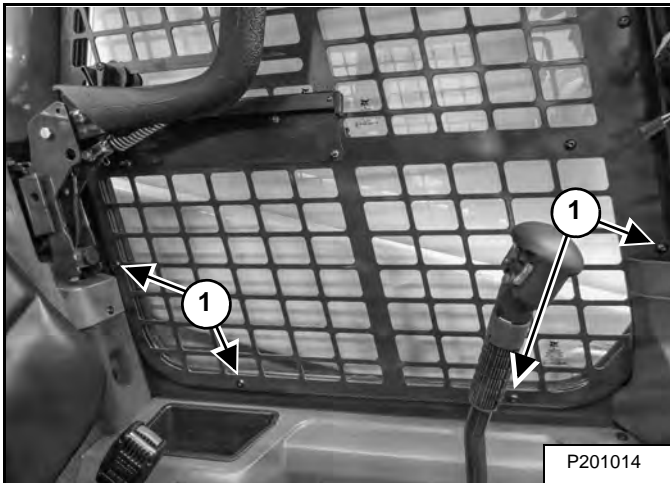

Support the side window assembly and remove the four remaining screws (Item 1) [Figure 50-132-2] and remove the side window assembly.

Installation: Tighten the screws to 9 - 10 N•m (80 - 90 in-lb) torque.

NOTE: The window assembly can only be replaced as a complete unit.

ARMREST (CONT'D)

Removal And Installation (Cont'd)

Figure 50-150-5

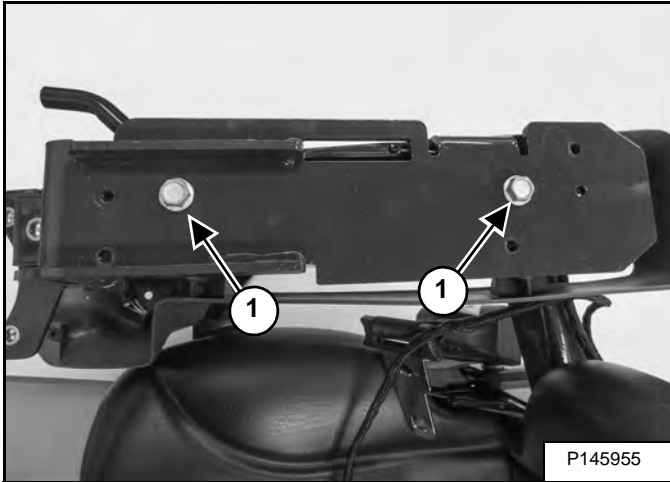

Remove the two screws (Item 1) [Figure 50-150-5].

Figure 50-150-6

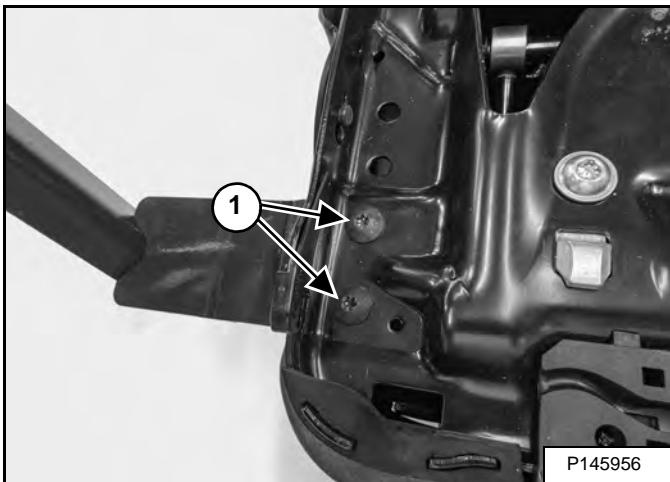

Remove the two screws (Item 1) [Figure 50-150-6] under seat bottom cushion.

Figure 50-150-7

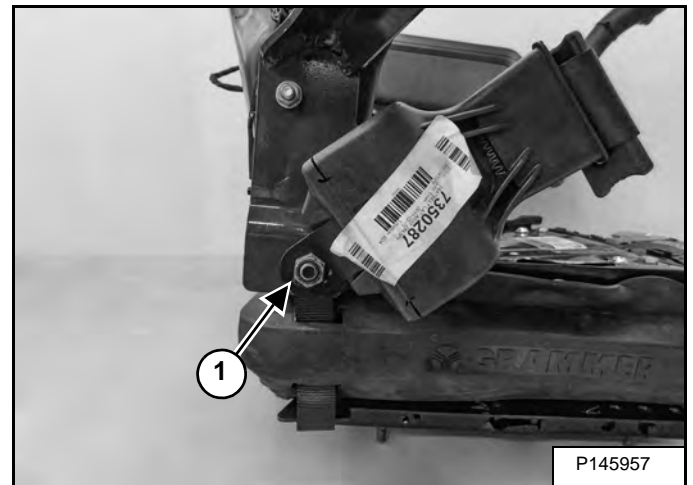

Remove the nut (Item 1) [Figure 50-150-7].

Figure 50-150-8

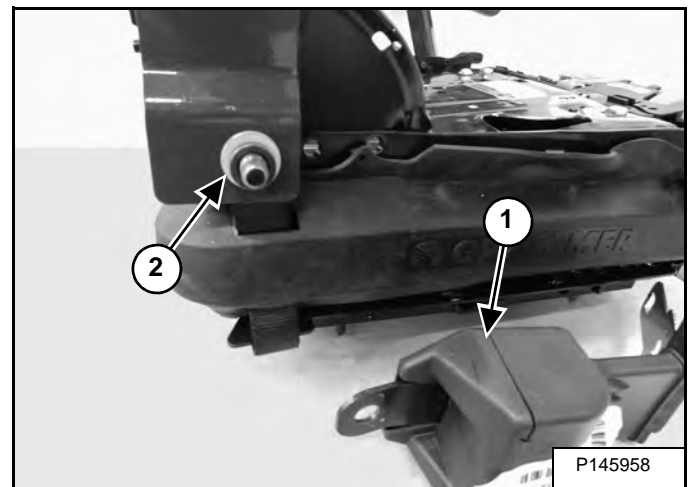

Remove the seat belt retractor (Item 1), washer and spacer (Item 2) [Figure 50-150-8].

Remove the armrest assembly.

CALIBRATION	60-150-1
Description	60-150-1
Actuator Testing	60-150-1
Lift And Tilt Calibration (SJC)	60-150-4
Adjusting Lift And Tilt Compensation	60-150-4
Hydrostatic Pump Calibration (SJC)	60-150-7
STEERING DRIFT COMPENSATION	60-160-1
Steering Drift Compensation Description	60-160-1
Adjusting Steering Drift Compensation	60-160-2
NAVIGATION (STANDARD DISPLAY)	60-170-1
Navigation Bar	60-170-1
Viewing Active Shortcuts	60-170-1
VITALS (STANDARD DISPLAY)	60-171-1
Vital Detail And Machine Performance	60-171-1
SERVICE (STANDARD DISPLAY)	60-172-1
Record A Service	60-172-1
SETTINGS (STANDARD DISPLAY)	60-173-1
Display Settings	60-173-1
Machine Settings	60-173-2
Language Settings	60-173-3
Units	60-173-4
Software	60-173-5
PASSWORD SETUP	60-180-1
Security Settings	60-180-1
Security Settings (Manage Operators)	60-180-2
CAMERA (TOUCH DISPLAY)	60-181-1
Camera Settings	60-181-1
PHONE (TOUCH DISPLAY)	60-182-1
AUDIO (TOUCH DISPLAY)	60-183-1
SERVICE (TOUCH DISPLAY)	60-184-1
Record A Service	60-184-1
View Service Schedule	60-184-2
View Service Record	60-184-3
View Service Codes	60-184-4
ATTACHMENTS (TOUCH DISPLAY)	60-185-1
Attachment Information	60-185-1

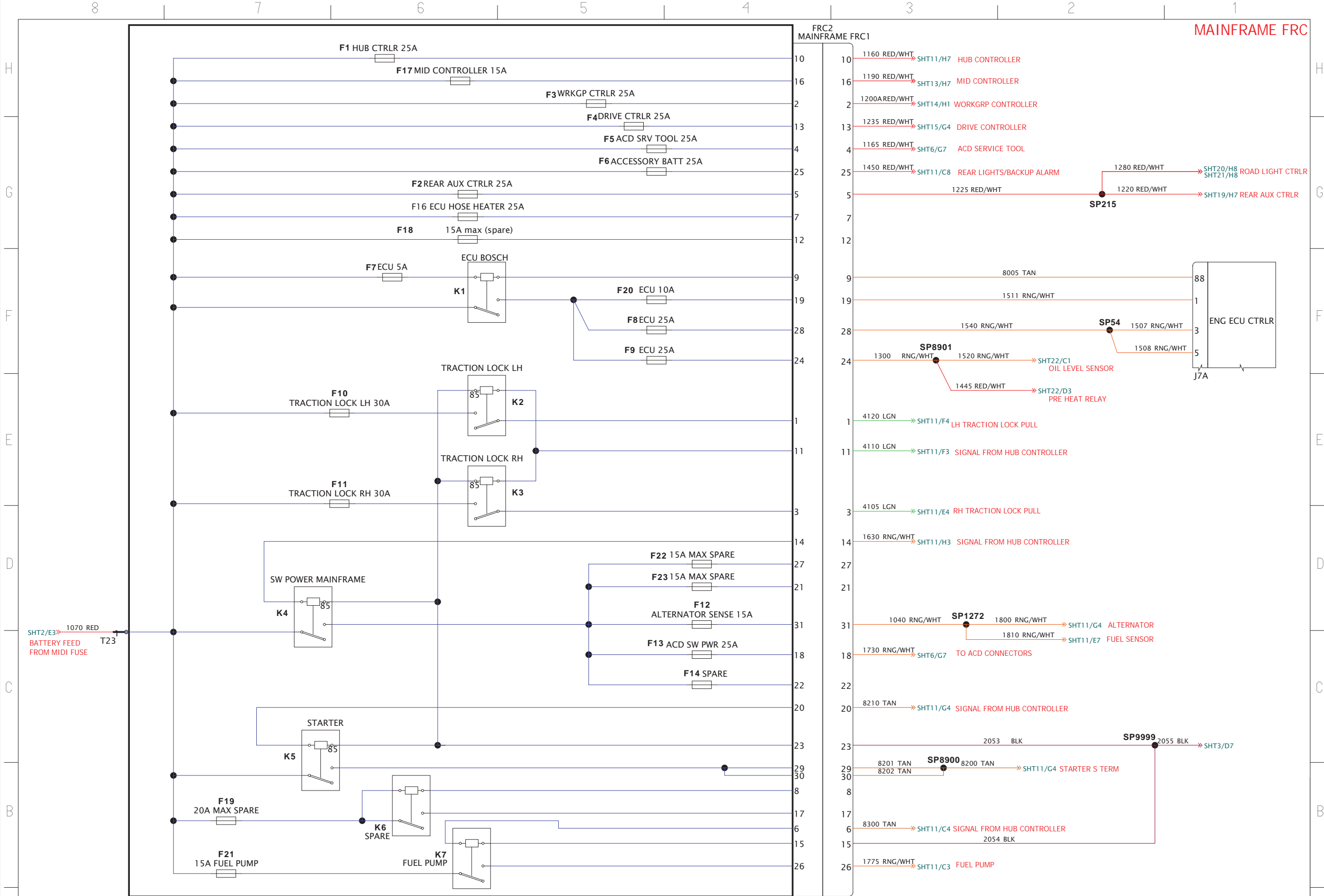

Wiring Schematic
Standard Machine

S76

S/N B4CD11001 & Above

Printed On April 2020
7400003 (F)
Sheet 9 of 23

[Printable Version Click Here](#)

7319142
REAR AUX CTLR

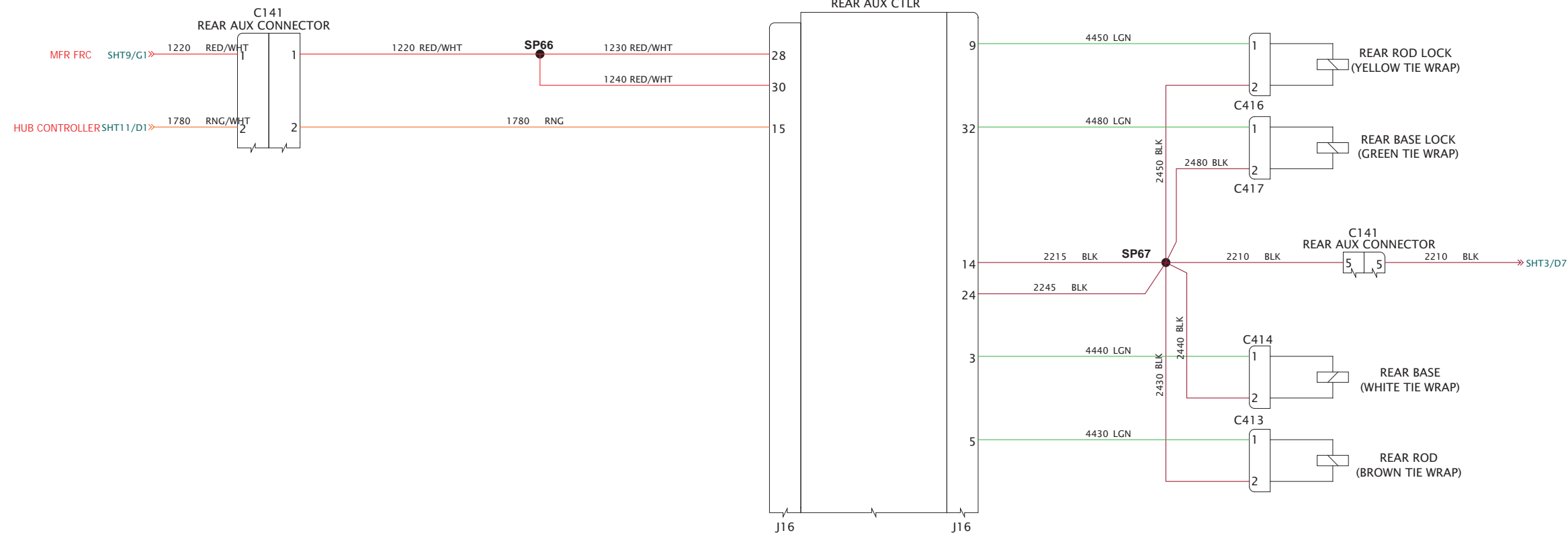

ELECTRICAL SYSTEM (CONT'D)

Fuse And Relay Identification

Master Fuse Panel

Figure 60-10-1

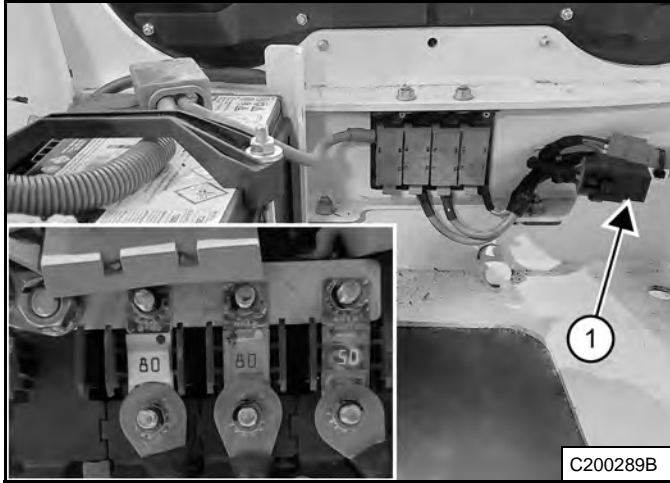

The master fuses (Inset) **[Figure 60-10-1]** are located next to the battery under the operator cab. (See Raising Operator Cab on Page 10-30-2.)

The glow plug relay (Item 1) **[Figure 60-10-1]** is located in the harness next to the master fuse panel under the operator cab. (See Raising Operator Cab on Page 10-30-2.)

Operator Cab Fuse Panel

Figure 60-10-2

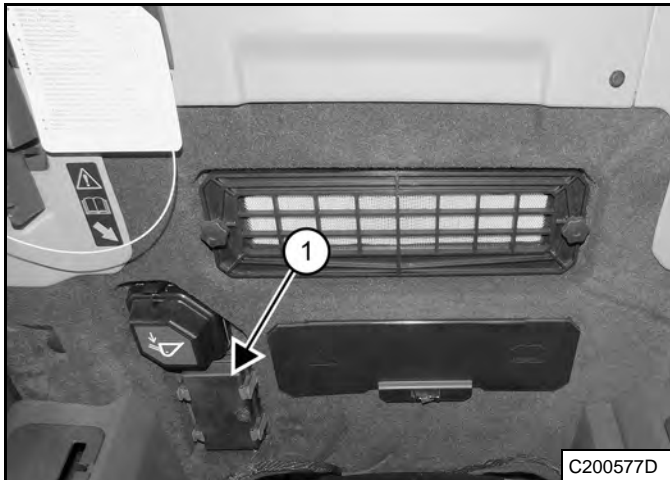

The operator cab fuse panel is located behind the operator seat on the right side. The cover (Item 1) **[Figure 60-10-2]** can be removed by opening four latches while pressing the cover tightly closed.

A decal **[Figure 60-10-3]** located inside the fuse panel cover indicates fuse and relay location and fuse amperage ratings.

Figure 60-10-3

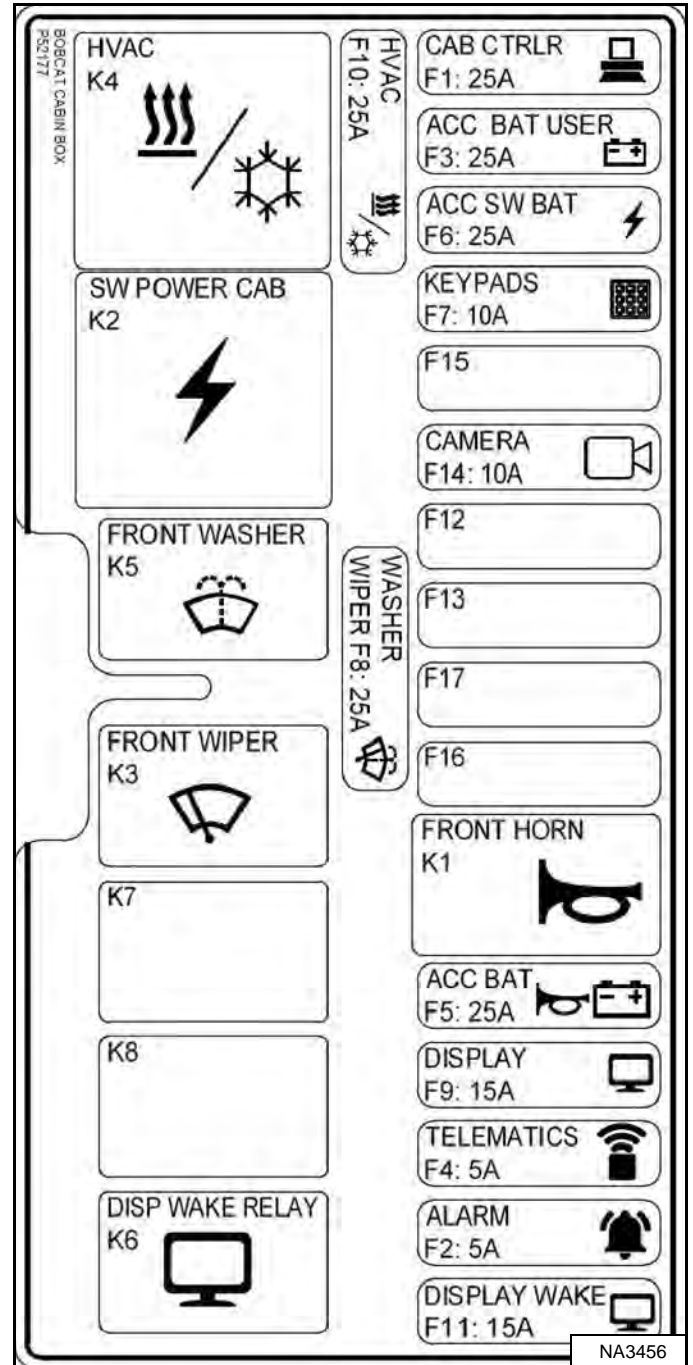

A table is provided with details on amperage ratings and the circuits affected by each fuse and relay. (See Operator Cab Fuse Panel (Cont'd) on Page 60-10-6.)

ALTERNATOR

Adjusting Belt (Machines Without Air Conditioning)

This belt is a special maintenance free type that is pretensioned over the pulleys. This belt eliminates the need for a tensioning device and does not require periodic adjustment. Contact your dealer for replacement parts.

Replacing Belt (Machines Without Air Conditioning)

A stretch fit belt tool is required to install the new belt. The tool is commonly available from an auto parts store or tool supplier.

1. Stop the engine.
2. Open the rear door.

Figure 60-30-1

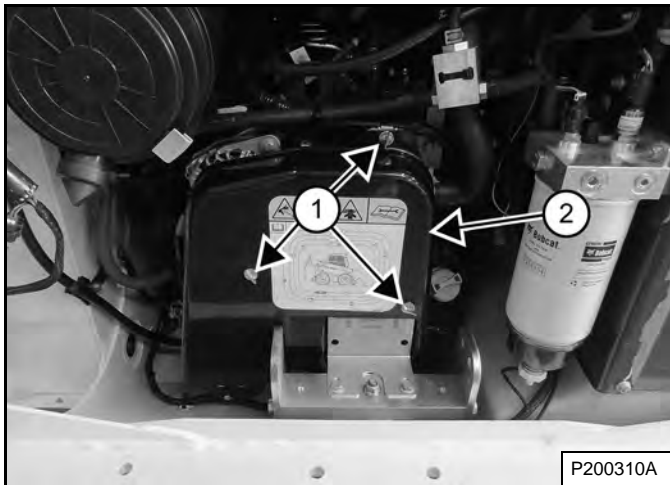

3. Loosen three fasteners (Item 1) and remove belt shield (Item 2) [Figure 60-30-1].

Figure 60-30-2

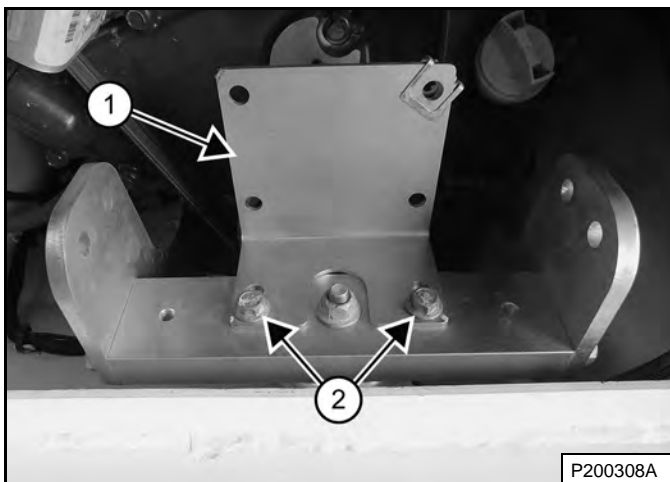

4. Remove two bolts (Item 2) and bracket (Item 1) [Figure 60-30-2].
5. Cut the old belt and remove the belt from the pulleys.
6. Inspect the pulleys for wear.

Figure 60-30-3

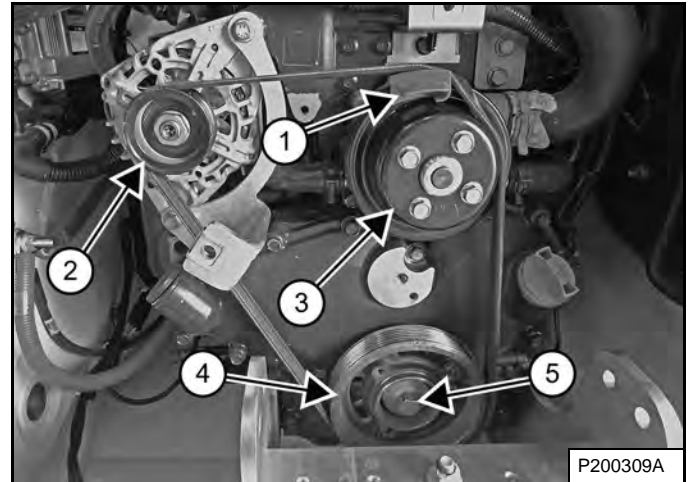

7. Install new belt around the crankshaft pulley (Item 4) and the alternator pulley (Item 2) [Figure 60-30-3].
8. Position the belt and the belt tool (Item 1) on the top side of the water pump pulley (Item 3) [Figure 60-30-3].
9. Rotate the engine clockwise using the large crankshaft pulley bolt (Item 5) [Figure 60-30-3].

Do not use the alternator pulley nut or the water pump pulley bolts.

10. Ensure the belt is fully installed on all three pulleys.
11. Repeat the procedure using the belt tool on each pulley if necessary until the belt is fully installed.
12. Remove the belt tool.
13. Install the bracket [Figure 60-30-2].
14. Install the belt shield [Figure 60-30-1].
15. Close the rear door.

INSTRUMENT PANEL IDENTIFICATION

Instrument Panel Overview

Figure 60-50-1

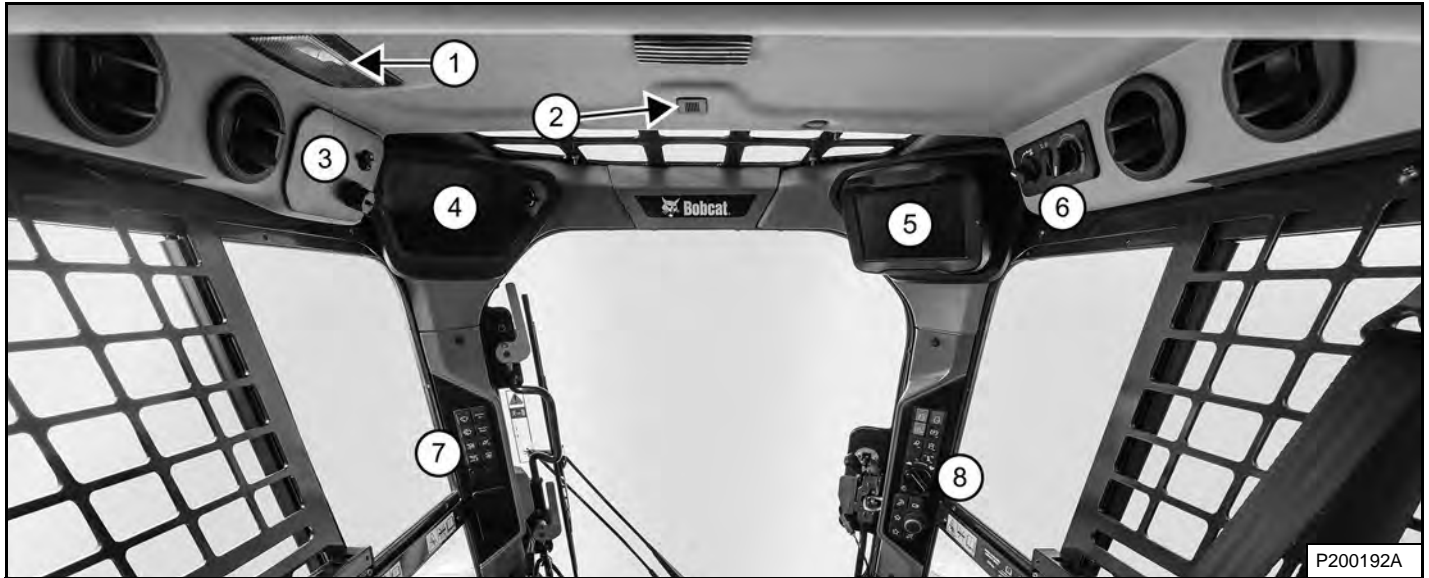

REF.	DESCRIPTION	FUNCTION
1	Cab Light	Press either side of the lens to turn the light on. Return the lens to the middle position to turn the light off.
2	Hands-Free Microphone	Used for hands-free talking with the touch display phone feature. Not installed with standard display.
3	Touch Display Radio Input Ports	(See Touch Display Radio Input Ports on Page 60-50-8.)
	Standard Display Optional Radio	(See Radio Identification on Page 60-50-10.)
4	Storage Compartment	Storage compartment includes a storage net and 12 volt power port for accessories.
5	Standard Display	(See Standard Display on Page 60-50-2.)
	Touch Display	(See Touch Display on Page 60-50-4.)
6	HVAC Controls (If equipped)	(See Heating, Ventilation, And Air Conditioning (HVAC) Controls on Page 60-50-8.)
7	Left Control Panel	Option controls. (See Left Control Panel on Page 60-50-6.)
8	Right Control Panel	Includes keyless start. (See Right Control Panel on Page 60-50-6.)

INSTRUMENT PANEL IDENTIFICATION (CONT'D)

Radio Identification (Cont'd)

REF.	DESCRIPTION	FUNCTION
1	POWER	Press to turn on; press again to turn off.
2	MUTE	Press to mute audio output; [MUTE] will appear in display screen; press again to turn off.
3	DISPLAY	Press to toggle between function mode (showing tuner frequency, auxiliary input, weather band information, or timer) and clock mode. Press and hold to enter clock setting mode; use FREQUENCY DOWN (TUN -) button to adjust hours and FREQUENCY UP (TUN +) button to adjust minutes; normal operation will resume automatically.
4	BAND	Press to select tuner mode. Press to cycle through 2 AM (MW) bands and 3 FM bands.
5	AUXILIARY	Press to select Auxiliary Input mode. Portable audio device (MP3 player) must be attached to auxiliary input jack.
6	WEATHER BAND	Press to select weather band; use FREQUENCY UP (TUN +) and FREQUENCY DOWN (TUN -) buttons to adjust to the clearest station. The weather alert feature, if activated, will automatically switch from the current function to the weather band if a weather warning is received. See AUDIO / MENU ADJUSTMENT in this table.
7	TIMER	Press to access timer mode. Press to start the timer function; press again to stop timer; press again to resume timer or press and hold to reset timer and exit from timer mode.
8	DISPLAY SCREEN	Displays the time, frequency, and activated functions.
9	VOLUME UP	Adjusts volume up; current volume (0 – 40) will appear briefly in display screen.
10	AUDIO / MENU ADJUSTMENT	AUDIO ADJUSTMENT: Press to cycle through bass, treble, and balance settings; use VOLUME UP (VOL +) and VOLUME DOWN (VOL -) buttons to adjust when desired option is displayed; normal operation will resume automatically. MENU ADJUSTMENT: Press and hold for 3 seconds to enter menu adjustment settings; press to cycle through the following settings; use VOLUME UP (VOL +) and VOLUME DOWN (VOL -) buttons to adjust when desired option is displayed; normal operation will resume automatically. <ul style="list-style-type: none"> • Beep Confirm (On or Off) – Determines if beep will sound with each button press. • Operation Region (USA or Europe) – Selects the appropriate region. • Clock Display (12 or 24) – Selects a 12-hour or 24-hour clock display. • Display Brightness (Low, Medium, or High) – Determines brightness level of display screen. • Backlight Color (Amber or Green) – Determines backlight color of display screen. • Power On Volume (0 – 40) – Selects default volume setting when radio is turned on. • WB Alert (On or Off) – Determines if weather band alert feature is activated.
11	FREQUENCY DOWN	Press to manually tune the radio frequency down.
12	FREQUENCY UP	Press to manually tune the radio frequency up.
13	VOLUME DOWN	Adjusts volume down; current volume (0 – 40) will appear briefly in display screen.
14	SEEK FREQUENCY DOWN	Press to automatically tune frequency down to next strong station.
15	SEEK FREQUENCY UP	Press to automatically tune frequency up to next strong station.
16	PRESET STATIONS	Used to store and recall stations for each AM and FM band. Press and hold to store current station; press button to recall station.
17	AUXILIARY INPUT JACK	Connect headphone or line output of portable audio device (MP3 player) to 3,5 mm (1/8 in) jack and press AUXILIARY button.

BOBCAT HUB CONTROLLER (CONT'D)

Removal And Installation

Raise the lift arms and install an approved lift arm support device. (See Installing Lift Arm Support Device on Page 10-20-1.)

Lift and block the loader. (See Procedure on Page 10-10-1.)

Raise the operator cab. (See Raising Operator Cab on Page 10-30-2.)

Disconnect the battery negative cable. (See Removing And Installing Battery on Page 60-20-1.)

Figure 60-70-3

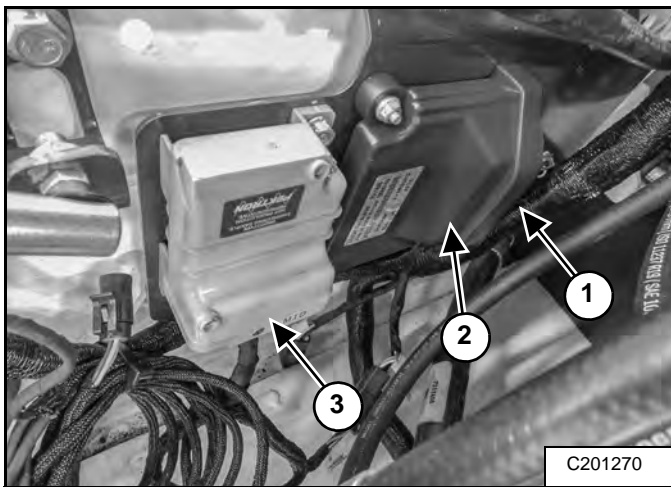

Disconnect the harness (Item 1) from the hub controller (Item 2) and the harness for the mid controller (Item 3) [Figure 60-70-3].

NOTE: The connectors are keyed and will only plug in one way.

Figure 60-70-4

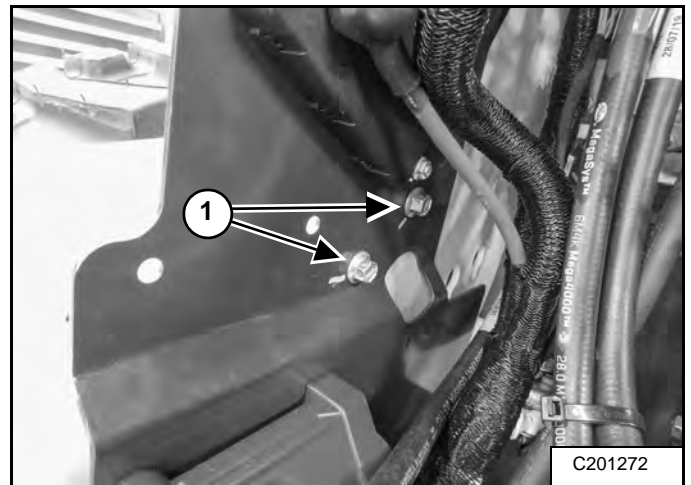

Remove the bolts (Item 1) [Figure 60-70-4].

Figure 60-70-5

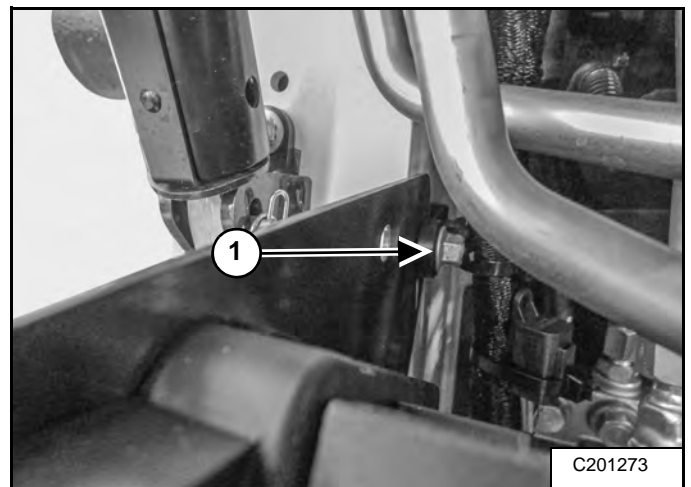

Remove the bolt (Item 1) [Figure 60-70-5].

ENGINE CONTROL UNIT (ECU) (CONT'D)

Removal And Installation

IMPORTANT

Avoid damaging the Engine Control Unit (ECU) and electrical connectors. Use care when removing or installing the ECU connectors.

I-2356-0512

Clean the connectors before removal. (See Cleaning on Page 60-80-2.)

Figure 60-80-6

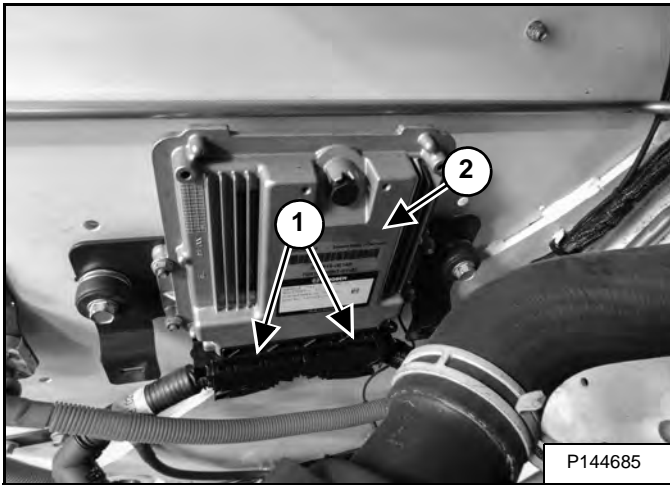

Remove the connectors (Item 1) from the ECU (Item 2) [Figure 60-80-6].

Figure 60-80-7

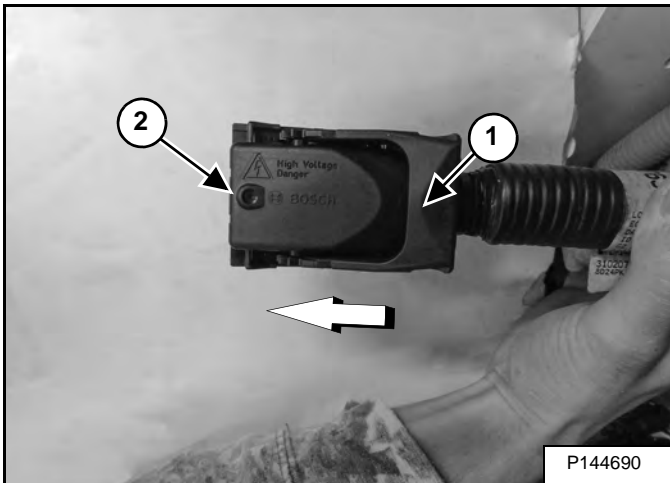

Lift the lever (Item 1) and push fully forward to remove connector (Item 2) [Figure 60-80-7].

Figure 60-80-8

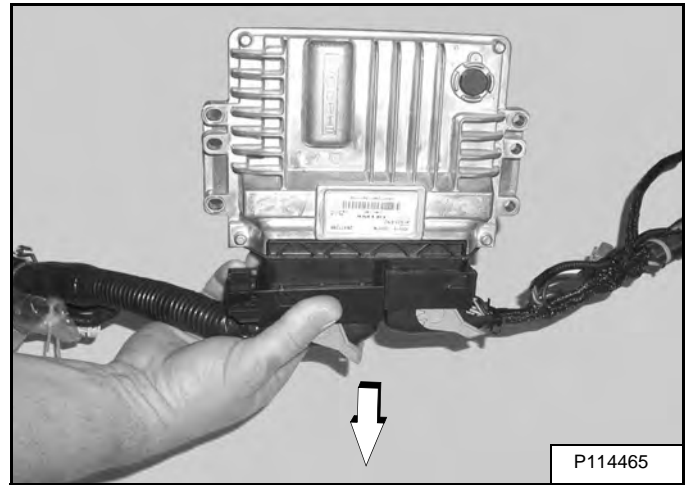

Pull connector straight out to avoid damage [Figure 60-80-8].

NOTE: Removing or installing the connector at an extreme angle will result in seal “scooping”, creating an environment for fluid ingress. Damage to the header or connector may result if undue force is used.

NOTE: If resistance is encountered when opening the lever, lock connector and repeat the cleaning process.

Repeat the above procedure on the remaining connector.

SEAT BAR SENSOR

Description

The seat bar sensor is part of the BICS™ system. The seat bar sensor sends a signal that indicates whether the seat bar is in the down or up position.

The sensor is located on the left side of the seat bar.

Troubleshooting

The following troubleshooting chart is provided for assistance in locating and correcting BICS™ system problems. It is recommended that these procedures be performed by authorized Bobcat Service Personnel only.



Check for correct function after adjustments, repairs or service. Failure to make correct repairs or adjustments can cause injury or death.

W-2004-1285

PROBLEM	SOLUTION #
Indicator icon does not turn OFF when seat bar is lowered.	1, 2, 3, 4, 5

SOLUTION SUGGESTIONS	
1.	Inspect sensor wire connection.
2.	Use the BICS™ Sensor Tester MEL1428 with seat bar adapter MEL1567 to test sensor and controller.
3.	Inspect for loose hardware.
4.	Inspect keyed bushing to make sure magnet collar rotates with seat bar.
5.	Inspect magnet collar magnets for contamination such as metal particles.

TRACTION LOCK (CONT'D)

Operating Parking Brake

Figure 60-120-1



1. Press the parking brake button (Item 1) [Figure 60-120-1] on the right control panel to engage the parking brake.

The LED in the button will light. The traction drive system is locked.

2. Move joystick(s) slowly forward and backward.

The traction lock must be engaged. See your dealer for service if loader fails to stop.

3. Press the button again to disengage the parking brake.

The LED in the button will turn off. The traction drive system is unlocked.

NOTE: The parking brake icon will remain visible on the display until the engine is started, the operate button is pressed, and the parking brake is disengaged.

Operating Hydraulic Controls With Parking Brake Engaged

The following steps allow you to activate the BICS and use loader lift and tilt functions without releasing the parking brake.

Figure 60-120-2

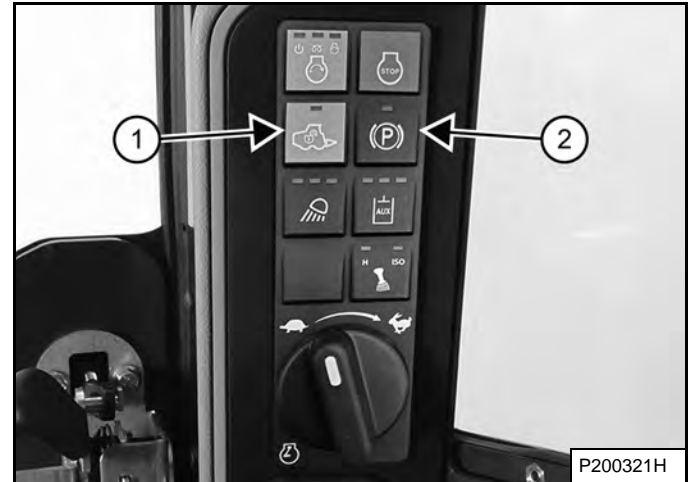

1. Press and hold the parking brake button (Item 2) [Figure 60-120-2] on the right control panel.
2. Press and hold the operate button (Item 1) [Figure 60-120-2] on the right control panel.
3. Release both buttons.

LIFT AND TILT COMPENSATION (CONT'D)

Adjusting Lift And Tilt Compensation (Cont'd)

Figure 60-150-4

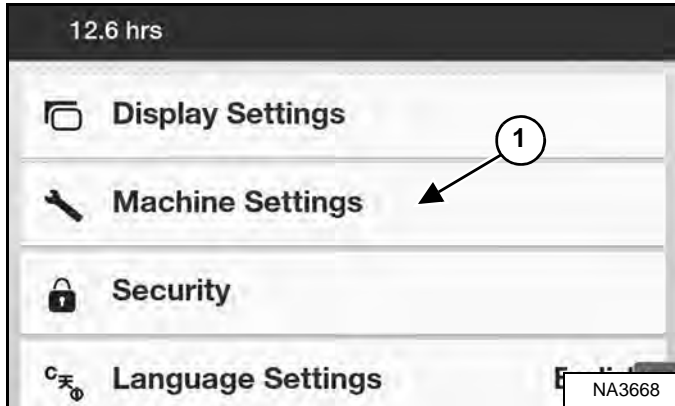

3. Select the Machine Settings icon (Item 1) [Figure 60-150-4].

Figure 60-150-5

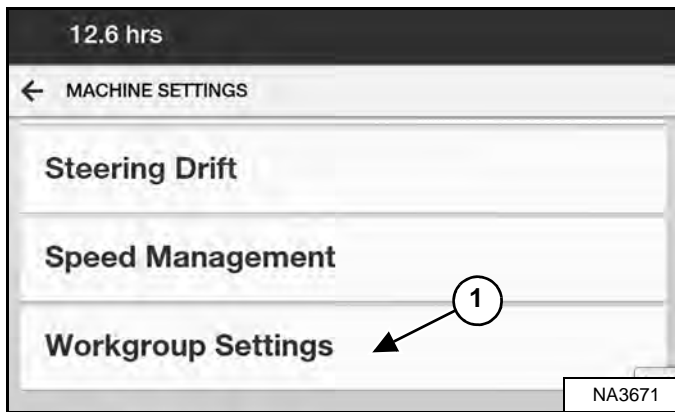

4. Scroll down and select the Work group Settings icon (Item 1) [Figure 60-150-5].

Figure 60-150-6

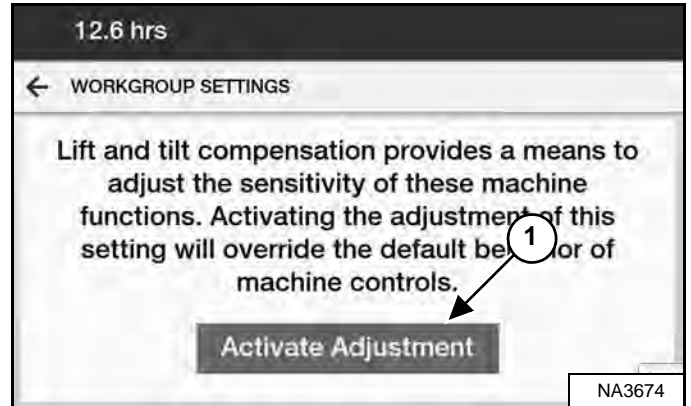

5. Select the Activate Adjustment icon (Item 1) [Figure 60-150-6].

Figure 60-150-7

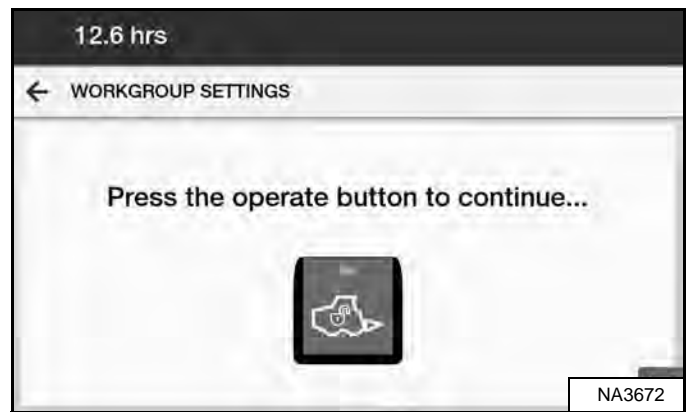

6. Press the operate button [Figure 60-150-7].

NOTE: When the procedure has begun, raising the seat bar will cause the machine to disengage from lift and tilt compensation. Changes made to the lift and tilt compensation settings will **NOT** be saved.

STEERING DRIFT COMPENSATION (CONT'D)

Adjusting Steering Drift Compensation (Cont'd)

Figure 60-160-6

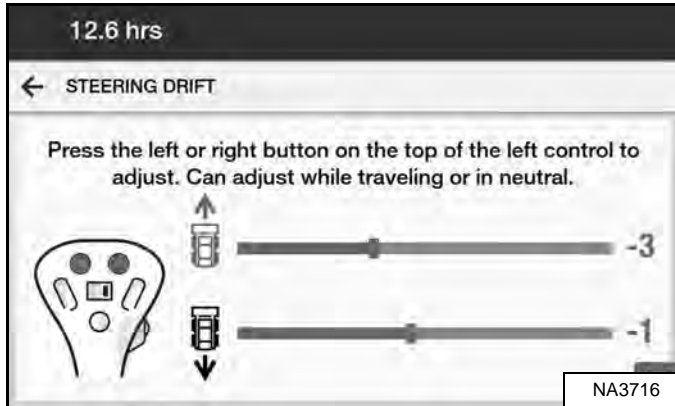

6. The bar graphs on the display will show the current steering drift settings for forward and reverse [Figure 60-160-6].

The current steering drift settings are automatically saved.

NOTE: Rear view camera will display when operating in reverse. Return controls to neutral to view settings.

SETTINGS (STANDARD DISPLAY) (CONT'D)

Language Settings

Figure 60-173-8



1. Select the navigation handle (Item 1) [Figure 60-173-8].
2. Select the SETTINGS icon (Item 2) [Figure 60-173-8].

Figure 60-173-9

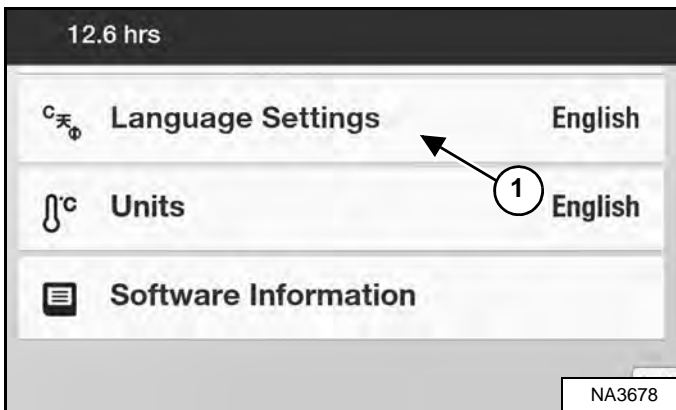

3. Select the Language Settings icon (Item 1) [Figure 60-173-9].

Figure 60-173-10



4. Scroll up or down and select the desired language [Figure 60-173-10]. The selected language will take effect immediately and is set for each operator.

AUDIO (TOUCH DISPLAY)

See your Touch Display User Guide for more information about audio settings.

SETTINGS (TOUCH DISPLAY) (CONT'D)

Display Settings

Figure 60-186-9



1. Select the SETTINGS icon (Item 1) [Figure 60-186-9].

Figure 60-186-10



2. Select the Display Settings icon (Item 1) [Figure 60-186-10].

Figure 60-186-11

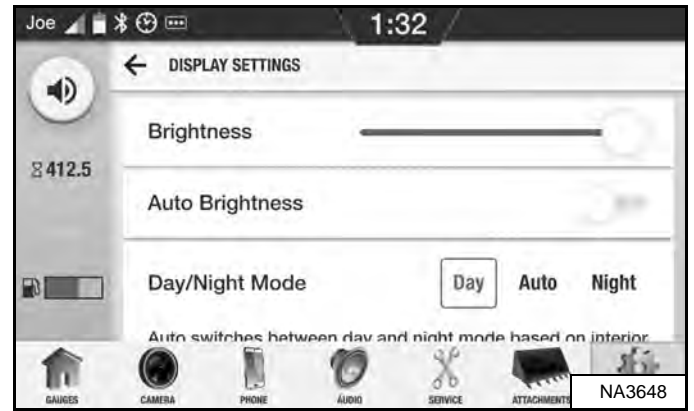
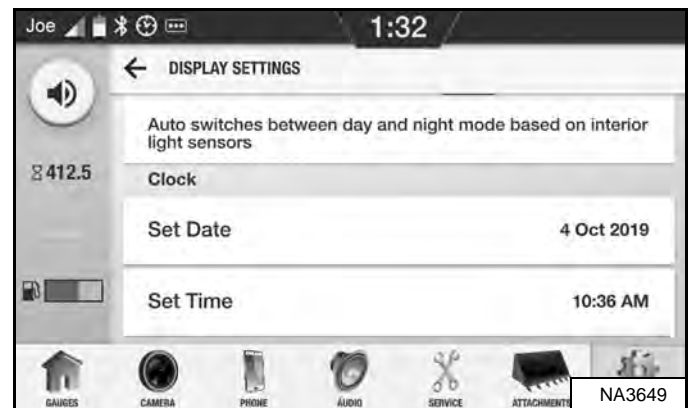

Figure 60-186-12



3. The following display settings are available [Figure 60-186-11] and [Figure 60-186-12]:
 - Screen brightness adjustment (Not available when auto brightness is on.)
 - Auto brightness on or off
 - Day / night mode settings
 - Set date
 - Set time

SETTINGS (TOUCH DISPLAY) (CONT'D)

Language Settings

Figure 60-186-44



1. Select the SETTINGS icon (Item 1) [Figure 60-186-44].

Figure 60-186-45



2. Scroll down and select the Language Settings icon (Item 1) [Figure 60-186-45].

Figure 60-186-46



3. The current language is identified by a check mark icon (Item 1) [Figure 60-186-46].
4. Scroll up or down and select the desired language. The selected language will take effect immediately and is set for each operator.

BACK-UP ALARM SYSTEM (CONT'D)

Troubleshooting (Joystick)

The following troubleshooting chart is provided for assistance in locating and correcting problems which are most common. Many of the recommended procedures must be done by authorized Bobcat Service Personnel only.



WARNING

AVOID INJURY OR DEATH

Instructions are necessary before operating or servicing machine. Read and understand the Operation & Maintenance Manual, Operator's Handbook and signs (decals) on machine. Follow warnings and instructions in the manuals when making repairs, adjustments or servicing. Check for correct function after adjustments, repairs or service. Untrained operators and failure to follow instructions can cause injury or death.

W-2003-0807

PROBLEM	CAUSE
Back-up alarm will not sound when the operator moves joystick(s) into the reverse position.	1, 2, 3, 4, 5, 6
Back-up alarm sounds when joystick(s) in neutral / forward position.	5, 6

KEY TO CORRECT THE CAUSE

1. The ground connection is not making a good contact.
2. The alarm is damaged.
3. The alarm wires are disconnected.
4. Inspect the fuses.
5. The wiring is damaged.
6. The joystick controller is not working correctly.

CAMSHAFT AND CRANKSHAFT POSITION SENSOR

Removal And Installation

Camshaft Position Sensor

Figure 60-240-1

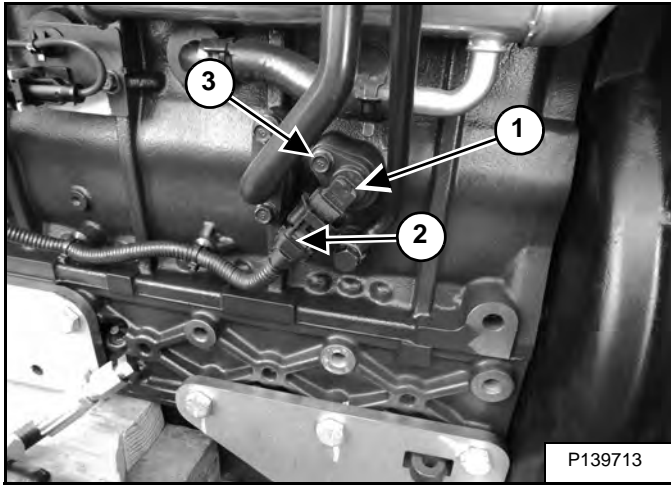

The camshaft sensor (Item 1) is located under the EGR cooler. Disconnect the wire harness connector (Item 2), remove the mounting bolt (Item 3) [Figure 60-240-1] and remove sensor.

Crankshaft Position Sensor

Figure 60-240-2

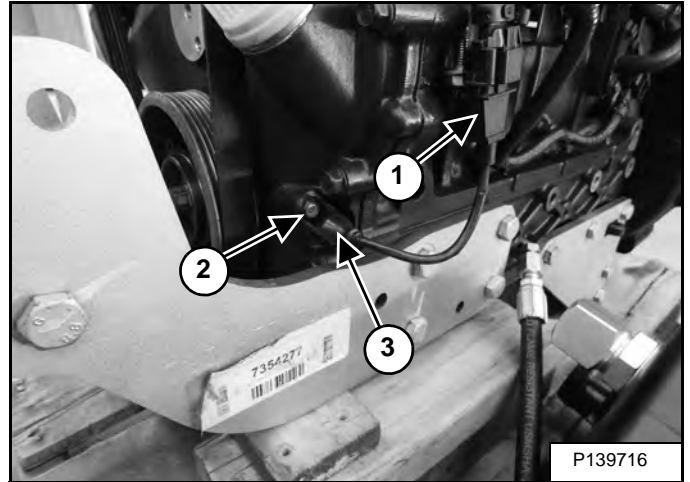

Disconnect the wire harness connector (Item 1), remove the mounting bolt (Item 2) and remove the sensor (Item 3) [Figure 60-240-2].

ENGINE INFORMATION (CONT'D)

Specifications (Cont'd)

Connecting Rod

Piston Pin O.D.	30,995 - 31,000 mm (1.2203 - 1.2205 in)
Small End Bushing I.D.	31,025 - 31,038 mm (1.2215 - 1.2220 in)
Oil Clearance Between Piston Pin And Small End Bushing	0,025 - 0,043 mm (0.0010- 0.0017 in)

Oil Pump

Oil Pressure Rated rpm	392 - 593 kPa (3,9 - 5,4 bar) (57 - 78 psi)
Idle Speed Allowable Limit	147 kPa (7,47 bar) (21 psi)

Crankshaft

Connecting Rod Large End Bore	57,0 - 57,015 mm (in)
Connecting Rod Oil Clearance (Large End Bore)	0,026 - 0,064 mm (in)
Connecting Rod End Play	0,15 - 0,30 mm (in)
Crankshaft Connecting Rod Journal	53,955 - 53,970 mm (in)
Oil Clearance Between Rod Journal and Bearing	0,029 - 0,059 mm (in)
Crankshaft End Play	0,10 - 0,31 mm (in)
I.D. of Cylinder Block Mainbearing Bore	
Class A	62,000 - 62,007 mm (2.4409 - 2.4412 in)
Class B	62,007 - 62,014 mm (2.4412 - 2.4415 in)
Class C	62,014 - 62,021 mm (2.4415 - 2.4418 in)
OD of Crankshaft Main Journal	
Class A	57,955 - 57,960 mm (2.2817 - 2.2819 in)
Class B	57,960 - 57,965 mm (2.2819 - 2.2821 in)
Class C	57,965 - 57,970 mm (2.2821 - 2.2823 in)
Mainbearing Thickness	
Blue	1,995 - 2,000 mm (0.0785 - 0.0787 in)
Yellow	2,000 - 2,005 mm (0.0787 - 0.0789 in)
Red	2,005 - 2,010 mm (0.0789 - 0.0791 in)

Timing Gear

Timing Gear Backlash:	
Fuel Injection Pump Gear To Idle Gear	0,087 - 0,200 mm (0.0034 - 0.0080 in)
Idle Gear To Crankshaft Gear	0,087 - 0,200 mm (0.0034 - 0.0080 in)
Idle Gear To Camshaft Gear	0,087 - 0,200 mm (0.0034 - 0.0080 in)
Crankshaft Gear To Oil Pump Gear	0,060 - 0,259 mm (0.0024 - 0.0010 in)

Thermostat

Valve Opening Temperature	82°C (180°F)
Valve Fully Open	97°C (207°F)

ENGINE INFORMATION (CONT'D)

Troubleshooting

The following troubleshooting chart is provided for assistance in locating and correcting problems which are most common. Many of the recommended procedures must be done by authorized Bobcat Service Personnel only.

PROBLEM	CAUSE
Slow cranking speed.	1, 2, 3, 54
Engine will not start.	2, 5, 6, 7, 8, 9, 10, 11, 12, 13, 14, 15, 16, 19, 27, 28, 29
Difficult to start.	1, 2, 5, 7, 8, 9, 10, 11, 12, 13, 15, 16, 17, 18, 19, 20, 25, 27, 28, 29,54
No power for engine.	8, 9, 10, 11, 12, 13, 15, 16, 17, 18, 20, 21, 22, 23, 27, 28, 29
Engine is mis-firing.	8, 9, 11, 12, 13, 15, 16, 17, 21, 22, 24, 25, 26, 28
Too much fuel consumption.	10, 12, 13, 15, 16, 17, 19, 20, 21, 23, 24, 25, 27, 28, 29
Black exhaust.	10, 12, 13, 15, 16, 17, 19, 20, 21, 23, 24, 25, 27, 28, 29
Blue / white exhaust.	4, 10, 15, 16, 17, 21, 23, 27, 29, 30, 50
Low oil pressure.	4, 31, 32, 33, 34, 35, 37, 38, 39, 52
Engine knocking.	13, 15, 16, 19, 22, 24, 25, 27, 29, 31, 40, 41, 53
Engine running rough.	7, 8, 9, 10, 11, 12, 13, 17, 18, 22, 24, 25, 26, 29, 40, 53
Vibration.	12, 13, 17, 21, 22, 25, 26, 29, 40, 42, 43
High oil pressure warning.	4, 33, 36
Overheating.	10, 12, 13, 15, 16, 20, 21, 40, 44, 45, 46, 47, 48, 51
Too much crankcase pressure.	22, 27, 29, 30, 40, 49
Poor compression.	10, 16, 21, 24, 25, 27, 28, 29, 30, 41, 53
Start and stop.	9, 10, 11

ENGINE INFORMATION (CONT'D)

Compression - Testing

NOTE: Specifications are subject to change without notice.

Remove the air cleaner housing. (See Housing Removal And Installation on Page 70-30-1.)

Prior to performing an engine compression test with a gauge, it is recommended to perform a compression test using Bobcat Engine Analyzer software to determine if a potential compression issue exists.

Wash the machine and then thoroughly clean the external portion of the fuel system components and the surrounding area of the engine compartment with compressed air. Perform engine service in a clean environment.

Figure 70-10-45

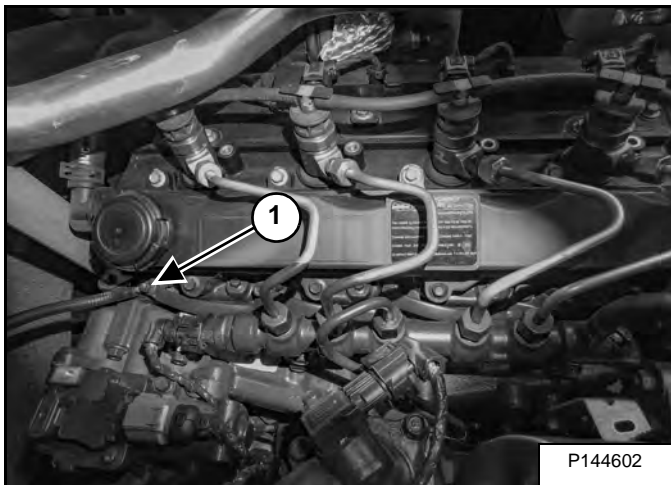

Remove wire and glow plug (Item 1) [Figure 70-10-45].

Figure 70-10-46

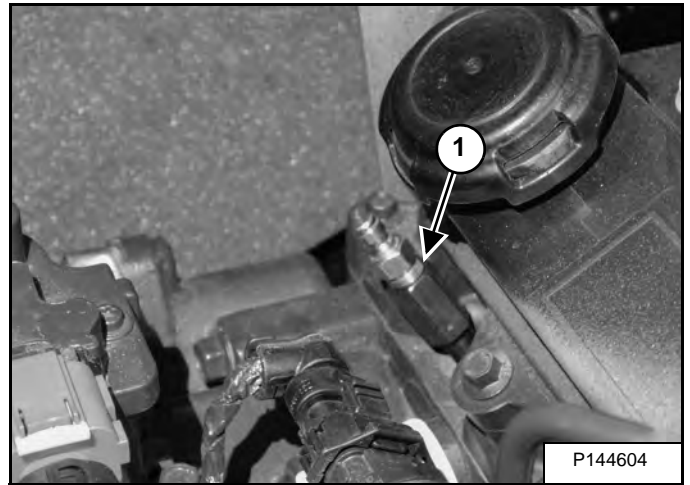

Install the compression tester and test adapter (part number 7313843) (Item 1) [Figure 70-10-46] for diesel engines into the glow plug hole.

Figure 70-10-47

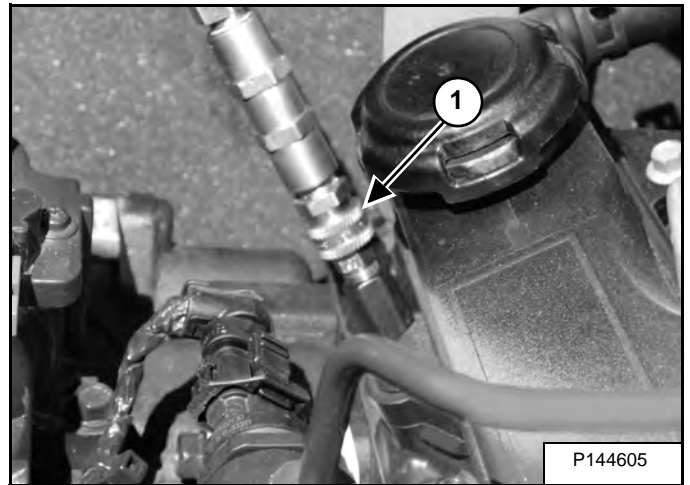

Install the compression tester adapter (Item 1) [Figure 70-10-47] on the glow plug adapter.

NOTE: Always use a fully charged battery for performing this test.

Monitor the engine crank speed to ensure that a minimum of 180 rpm is achieved or reading will not be valid.

Connect the Bobcat Engine Analyzer Diagnostic Tool and run the Compression test in Bobcat Engine Analyzer. This test will cause the engine to crank while the test is running. Observe the maximum compression reading on the compression gauge during cranking, not the test results shown on the computer screen.

Repeat this procedure multiple times per cylinder until an average reading is recorded.

AIR CLEANER

Housing Removal And Installation

Open the rear door

Raise the rear grille and cooling assembly.

Figure 70-30-1

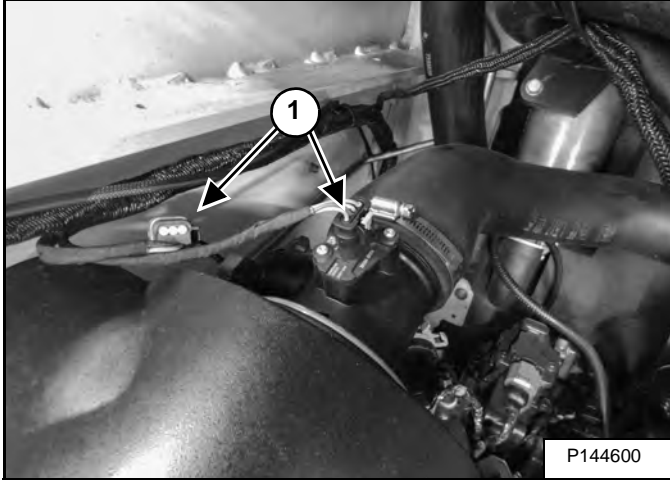

Disconnect the two wire harness connectors (Item 1) [Figure 70-30-1].

Figure 70-30-2

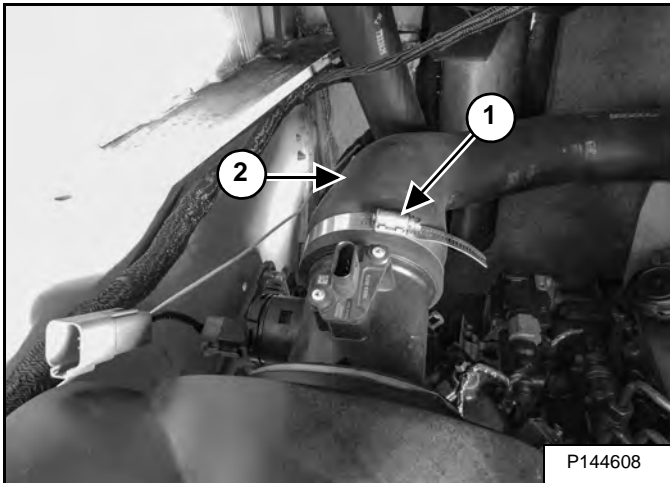

Reposition the hose clamp (Item 1) and remove the hose (Item 2) [Figure 70-30-2].

Figure 70-30-3

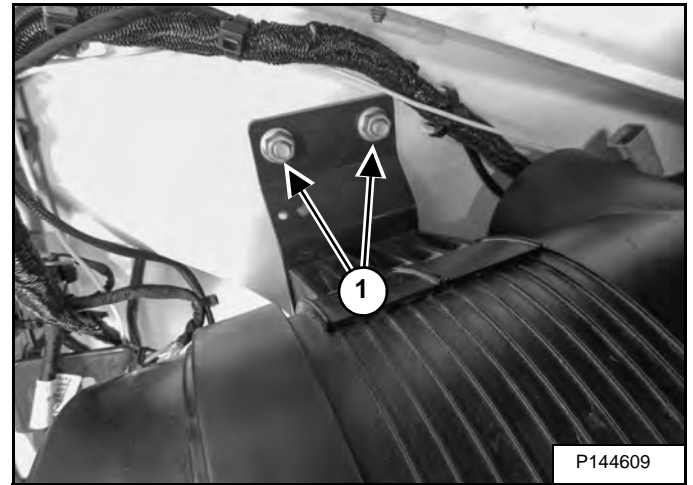

Remove the two nuts (Item 1) [Figure 70-30-3].

Remove the air cleaner housing.

ENGINE COOLING SYSTEM (CONT'D)

Hydraulic Fan Motor Removal And Installation

Figure 70-40-25

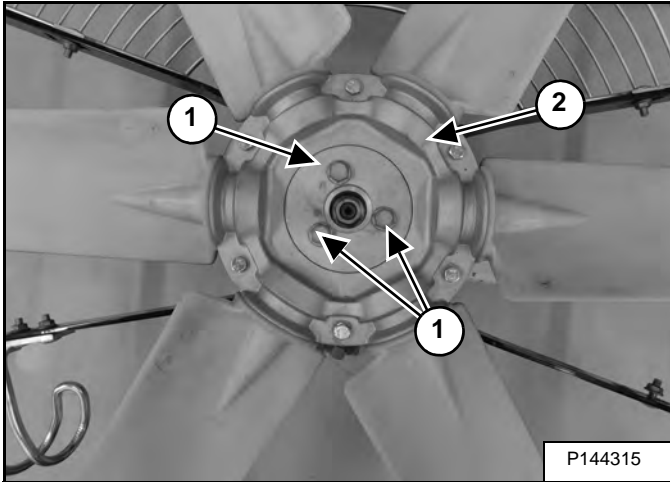

Remove the three bolts (Item 1) and the fan assembly (Item 2) [Figure 70-40-25].

Installation: Tighten the bolts to 10,2 N•m (7.5 ft-lb) torque.

Figure 70-40-26

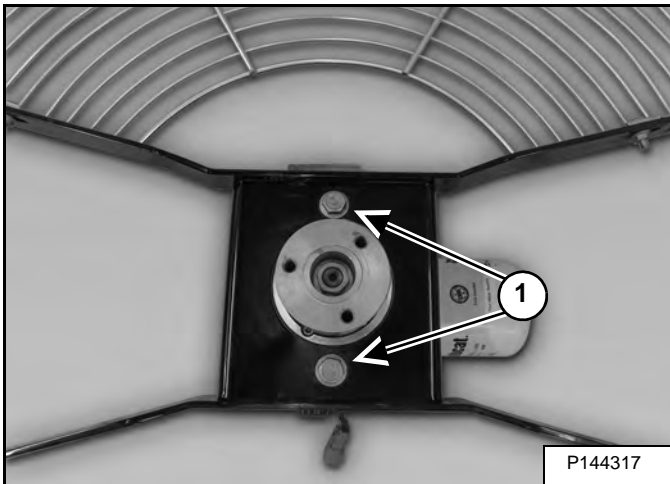

Remove the nuts and bolts (Item 1) [Figure 70-40-26] and remove the fan motor.

ENGINE COOLING SYSTEM (CONT'D)

Hydraulic Fan Motor Disassembly And Assembly (Cont'd)

Figure 70-40-61

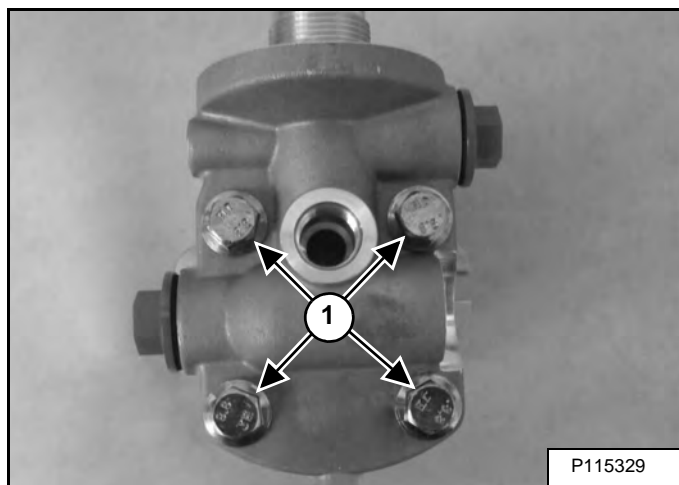

Assemble the fan motor and the filter adapter. Install the four bolts (Item 1) [Figure 70-40-61].

Installation: Tighten the four bolts to 37 - 45 N•m (27 - 33 ft-lb) torque.

LUBRICATION SYSTEM (CONT'D)

Oil Cooler Bypass Description

The oil cooler bypass is set to 145 kPa (1,4 bar) (21 psi).

Oil Cooler Bypass Removal And Installation

Figure 70-50-19

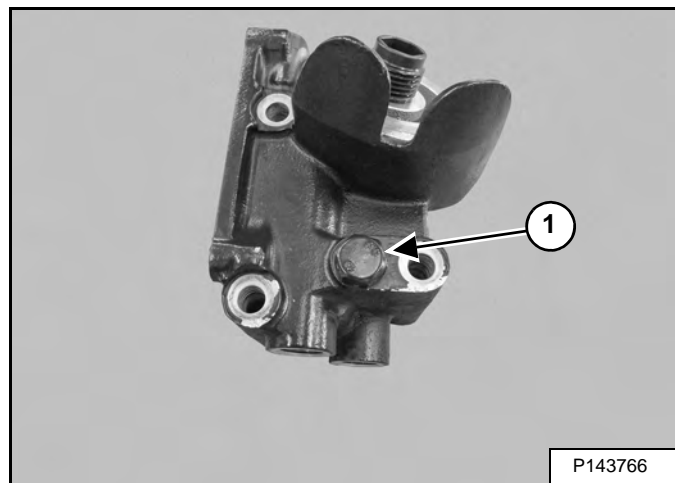

Remove the plug (Item 1) [Figure 70-50-19].

FUEL SYSTEM (CONT'D)

Fuel Injector Removal And Installation

Figure 70-60-23

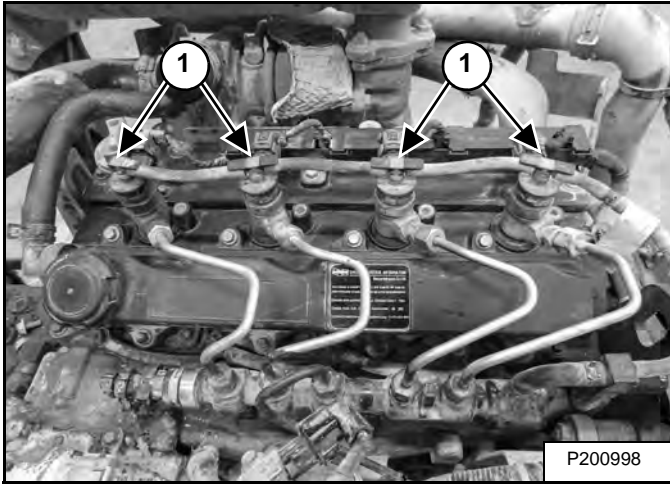

Remove the fuel return lines (Item 1) [Figure 70-60-23].

NOTE: The fuel return line fittings are delicate and should be removed with care to prevent leaks.

Figure 70-60-24

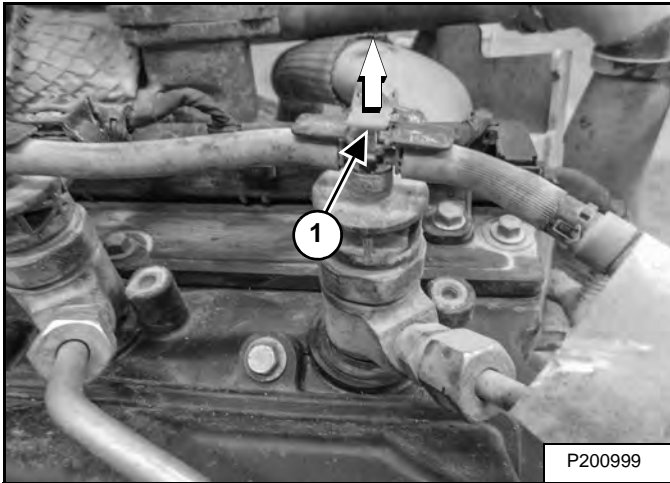

Raise the fuel return line lock (Item 1) [Figure 70-60-24] to release the line from the injector.

Figure 70-60-25

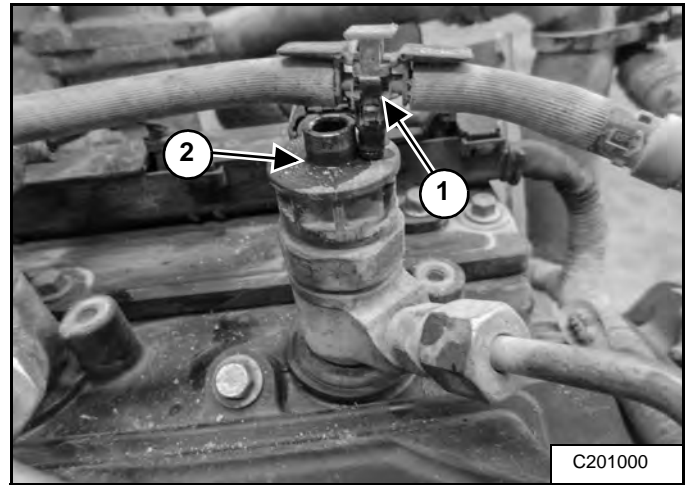

Fuel return line (Item 1) shown removed from injector (Item 2) [Figure 70-60-25].

Figure 70-60-26

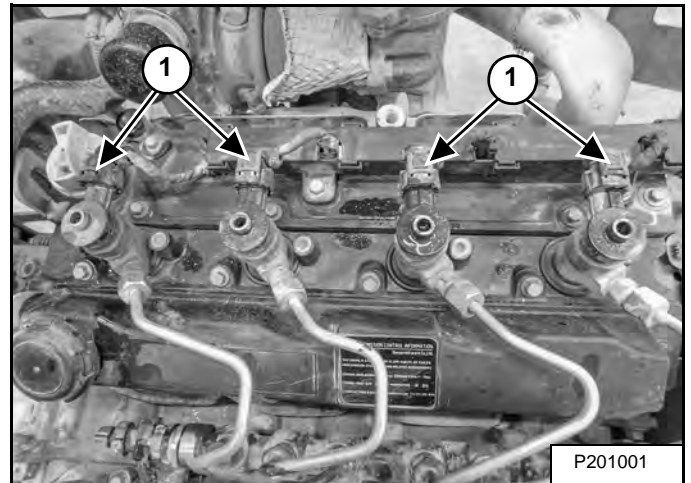

Disconnect the fuel injector wire harness connector (Item 1) [Figure 70-60-26].

CYLINDER HEAD (CONT'D)

Cylinder Head Removal And Installation (Cont'd)

Figure 70-70-22

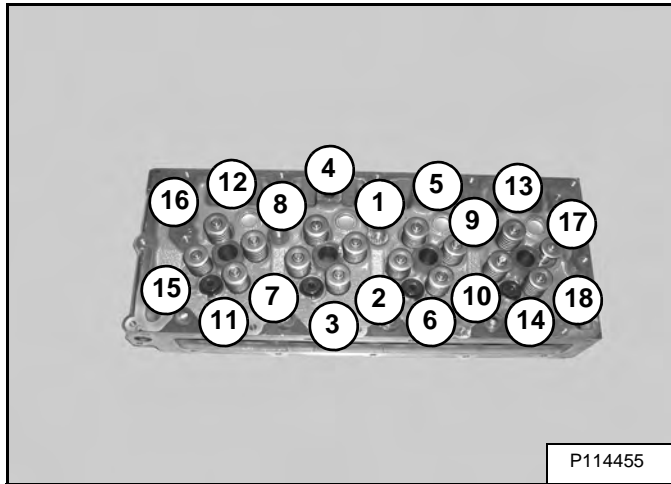

Installation: Tighten the head bolts in the sequence shown [Figure 70-70-22].

Initial torque 40 N•m (30 ft-lb).

2nd torque 90°.

3rd torque 90°.

4th torque 90°.

NOTE: Before installing the cylinder head, piston step height must be measured to determine the correct head gasket thickness required.

Figure 70-70-23

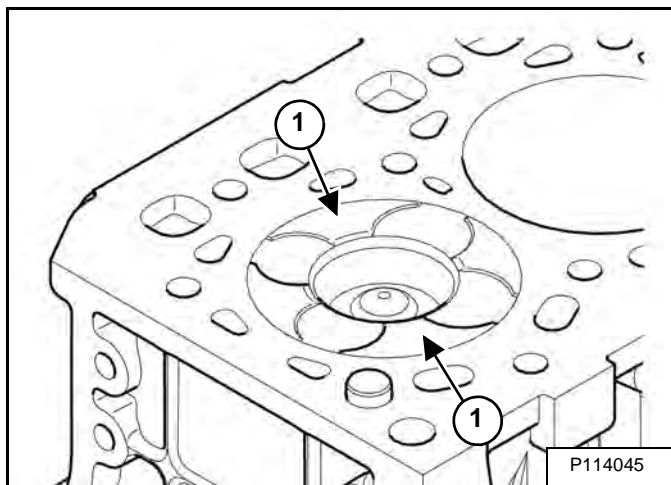

Rotate the crankshaft until the piston is at top dead center. Measure the piston step height in the areas shown (Item 1) [Figure 70-70-23].

Repeat the procedure for all four pistons

Piston step height	0,11 - 0,39 mm (0.0043 - 0.0154 in)
--------------------	--

Figure 70-70-24

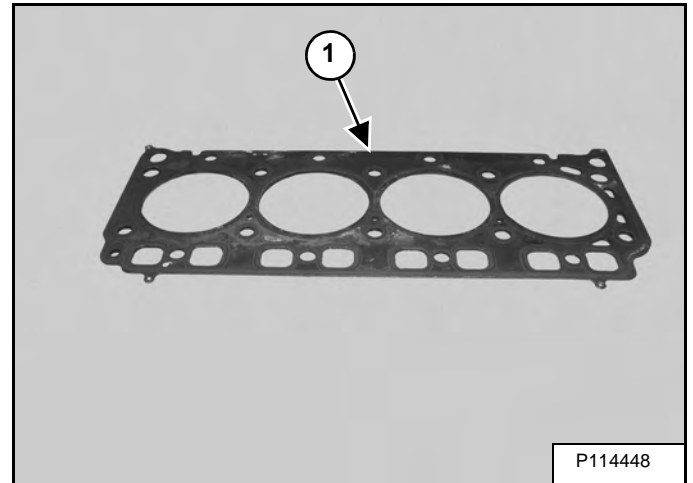

Select the correct class head gasket. The class of gasket is stamped in the gasket where shown (Item 1) [Figure 70-70-24].

Gasket Class and Thickness	Average Piston Step Height
Class A 0,77 mm (0.0303 in)	0,11 - 0,20 mm (0.0043 - 0.0079in)
Class B 0,87 mm (0.0343 in)	0,20 - 0,30 mm (0.0079 - 0.0118 in)
Class C 0,97 mm (0.0382 in)	0,30 - 0,39 mm (0.0118 - 0.0154 in)

CRANKSHAFT AND PISTONS

Piston And Connecting Rod Removal And Installation

Remove the cylinder head. (See Cylinder Head Removal And Installation on Page 70-70-5.)

Remove the top edge from the cylinder bore with a ridge reamer.

Remove the oil pan and oil pump strainer. (See Oil Pan Removal And Installation on Page 70-50-2.)

Figure 70-80-1

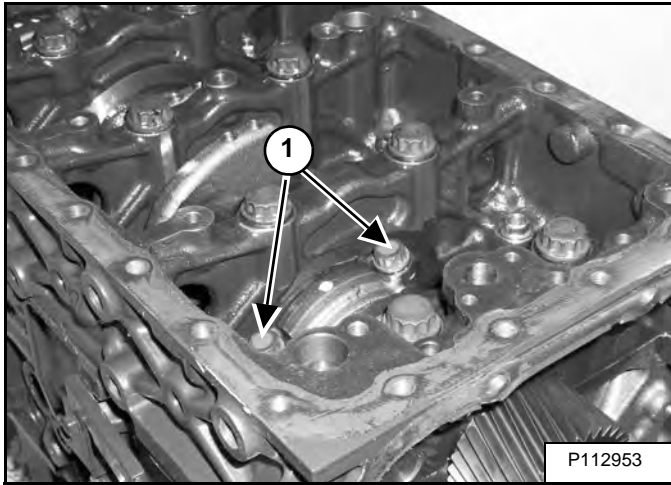

Remove the connecting rod bolts (Item 1) [Figure 70-80-1].

Installation: Tighten the bolts to an initial torque of 19,6 N•m (14.5 ft-lb). Tighten the bolts an additional 90°.

NOTE: The rod bolts are a one time use bolt. Use new bolts when installing the connecting rods.

Figure 70-80-2

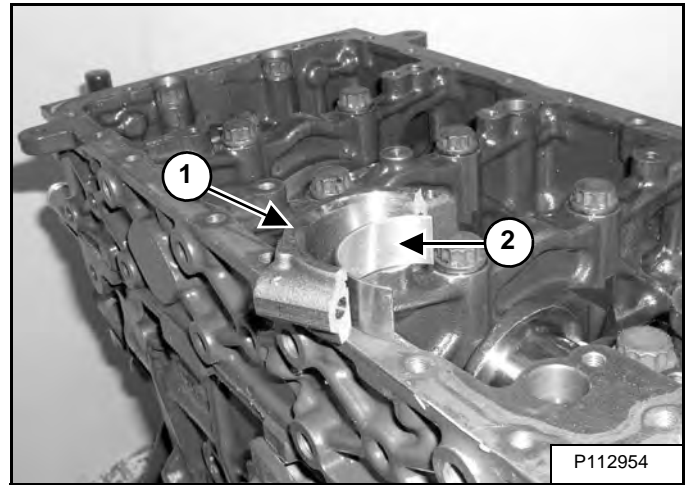

Remove the cap (Item 1) and bearing (Item 2) [Figure 70-80-2].

Figure 70-80-3

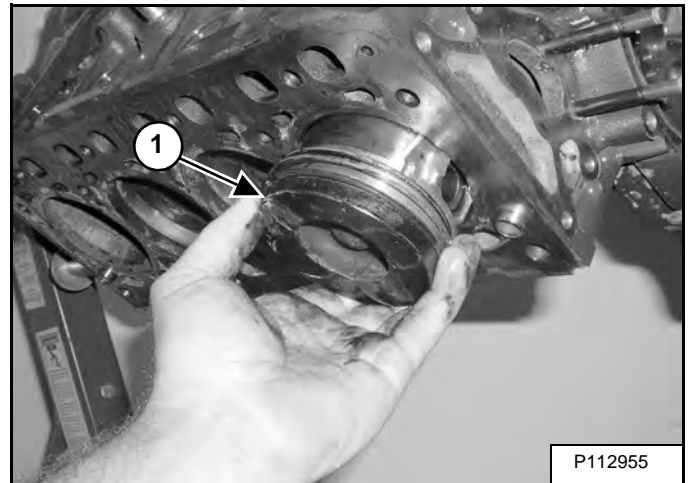

Remove the piston / connecting rod (Item 1) [Figure 70-80-3] from the cylinder block.

NOTE: Install the piston / connecting rod assembly in to the bore it was removed from.

Repeat the procedure to remove the remaining piston / connecting rod assemblies.

CRANKSHAFT AND PISTONS (CONT'D)

Engine Component Class (Cont'd)

Figure 70-80-34

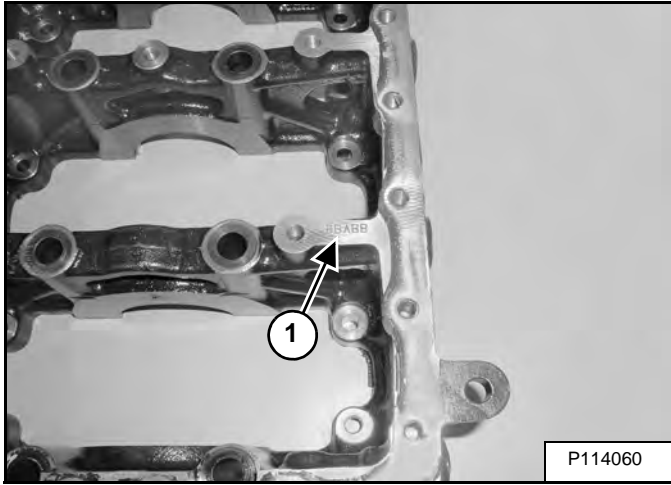

The cylinder block bearing bore class (Item 1) [Figure 70-80-34] is engraved on the flange of the crankcase.

Cylinder Block Main Journal Diameter	
Class A	62,000 - 62,007 mm (2.4409 - 2.4412 in)
Class B	62,007 - 62,014 mm (2.4412 - 2.4415 in)
Class C	62,014 - 62,021 mm (2.4415 - 2.4418 in)

When replacing crankshaft bearings, use the chart below.

Cylinder Block Main Journal Diameter	Crankshaft Main Journal Diameter		
	Class A	Class B	Class C
Class A	Yellow Bearing	Blue Bearing	Blue Bearing
Class B	Yellow Bearing	Yellow Bearing	Blue Bearing
Class C	Red Bearing	Red Bearing	Yellow Bearing

TURBOCHARGER

Description

The turbocharger is located between the exhaust and intake manifolds. It is driven by hot exhaust gases and supplies air at more than atmospheric pressure to the intake. It is lubricated by oil from the main galley. The location of the turbo is between the engine and the blower housing.

Figure 70-110-1

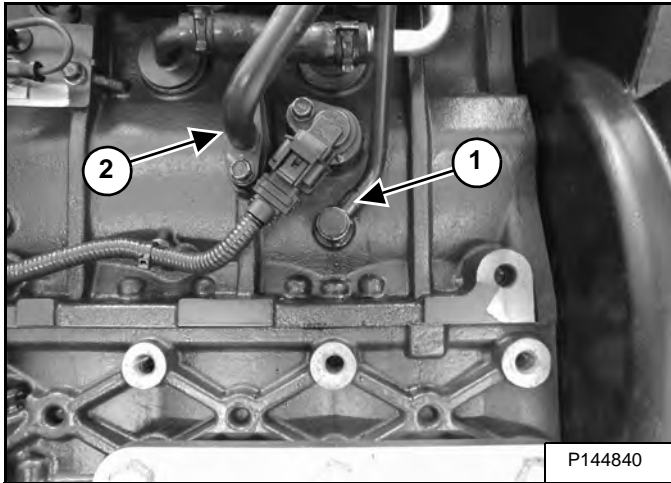

The oil is delivered to the turbocharger through a tubeline (Item 1) and returns to the engine block through a drain line (Item 2) [Figure 70-110-1].

The turbocharger internal components are not serviceable.

Removal And Installation

NOTE: Procedure shown with engine removed for photo clarity.

Remove the DOC assembly. (See Removal And Installation on Page 70-20-1.)

Figure 70-110-2

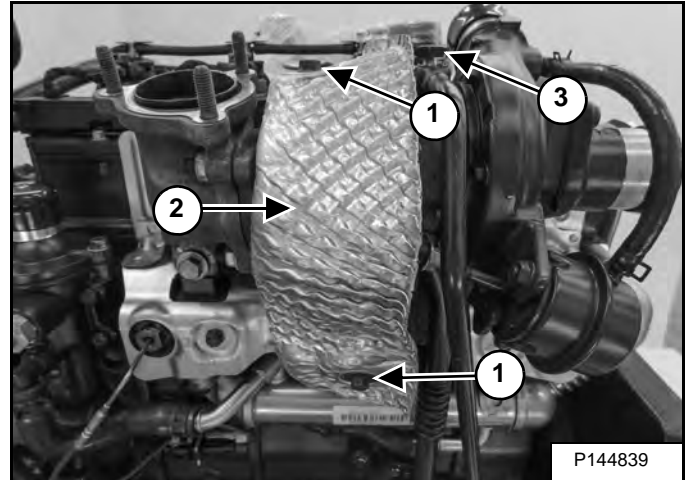

Remove the two bolts (Item 1), heat shield (Item 2) and tubeline bolt (Item 3) [Figure 70-110-2].

NOTE: Replace the copper sealing washer on both sides of the tubeline fitting.

Plug the port on the turbocharger.

Figure 70-110-3

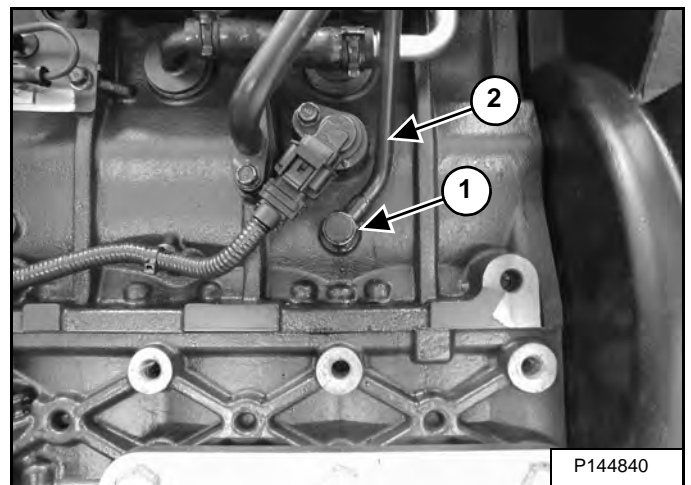

Remove the tubeline bolt (Item 1) and tubeline (Item 2) [Figure 70-110-3].

NOTE: Replace the copper sealing washer on both sides of the tubeline fitting.

Installation: Tighten the bolt to 22 N•m (16 ft-lb) torque.

Plug the port on the block.

**EXHAUST GAS RECIRCULATION (EGR) SYSTEM
(CONT'D)**

Removal And Installation (Cont'd)

Figure 70-130-5

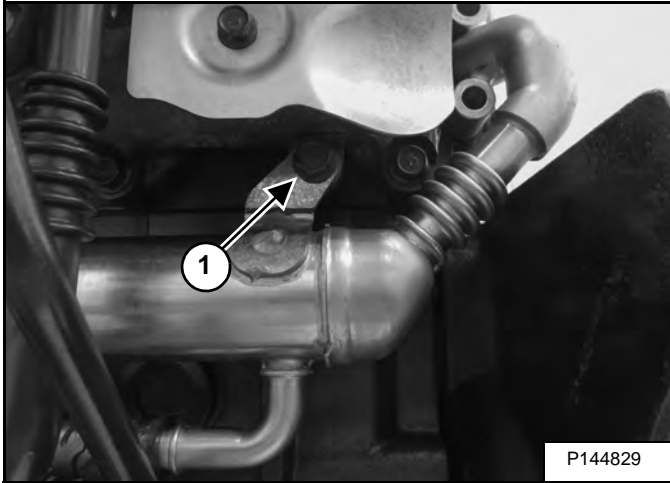

Remove the bolt (Item 1) [Figure 70-130-5].

Figure 70-130-6

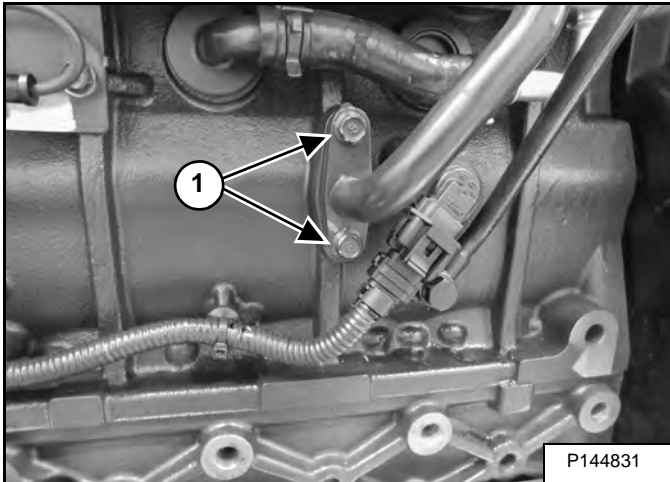

Remove the two bolts (Item 1) [Figure 70-130-6].

Figure 70-130-7

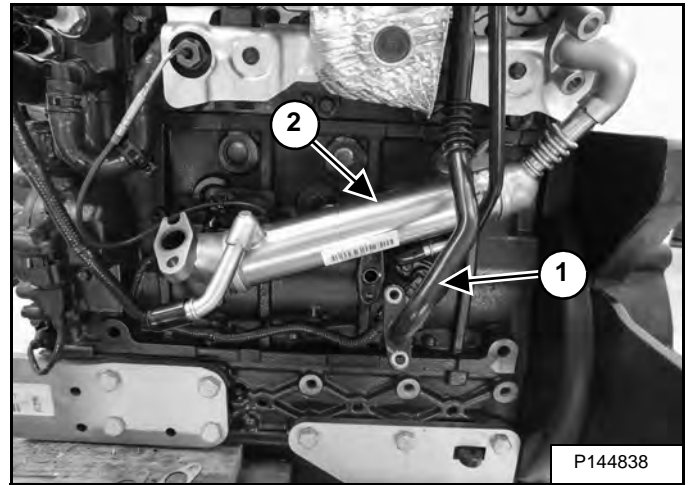

Reposition turbocharger oil drain tube (Item 1) and remove the EGR cooler (Item 2) [Figure 70-130-7].

AIR CONDITIONING SYSTEM FLOW (CONT'D)

Components (Cont'd)

Figure 80-10-9

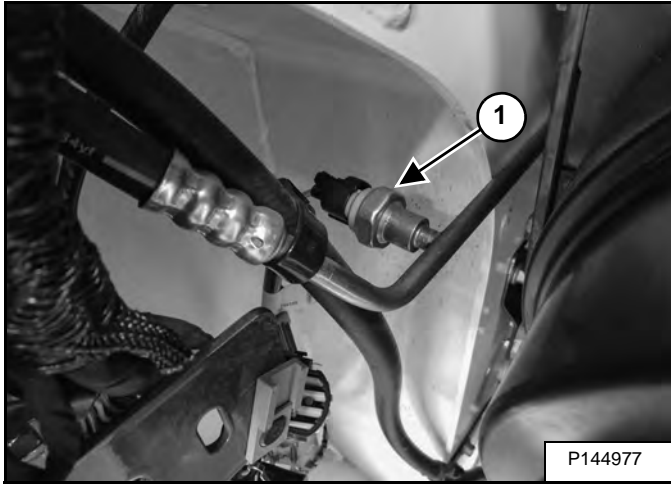

Pressure Switch: The pressure switch (Item 1) [Figure 80-10-9] will disengage the compressor clutch at high pressure readings over 2648 kPa (26,5 bar) (384 psi) on the high side, or at very low pressure of 193 kPa (1,9 bar) (28 psi) or less on the high side, which indicates loss of refrigerant.

TROUBLESHOOTING (CONT'D)

Gauge Pressure Related Troubleshooting (Cont'd)

Possible Cause	Inspection	Solution
High pressure side Too low.		
1. Low refrigerant charge.	The high side pressure will be low.	Repair any leaks and recharge the refrigerant to the correct level.
System pressures Equal		
1. Clutch not operating.	See magnetic clutch related topics above.	
2. Compressor not pumping.	Equal high and low pressures.	Replace compressor.

TROUBLESHOOTING (CONT'D)

Electrical System (Cont'd)

Figure 80-30-8

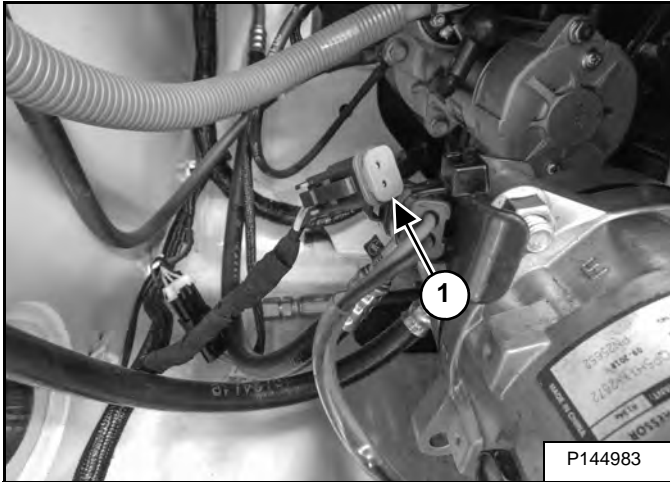

With a multimeter, test the voltage to the compressor clutch at the loader harness connector (Item 1) [Figure 80-30-8].

The voltage reading should be around 12 volts.

If there is no power at the clutch, inspect the wiring harness for broken wires.

If there is power at the clutch, reconnect the wiring harness to the compressor clutch.

Figure 80-30-9

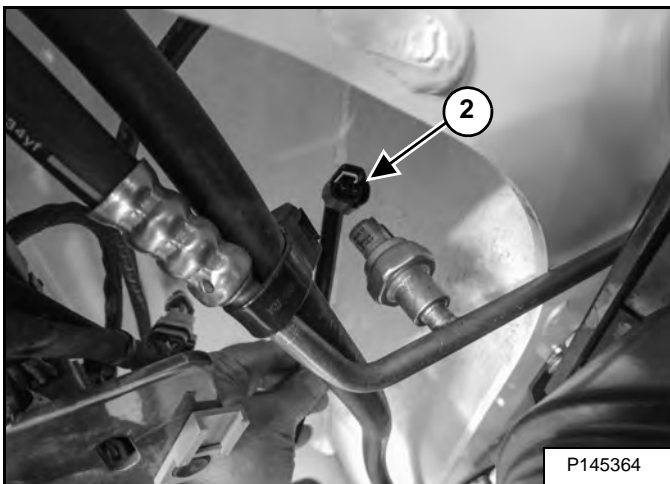

Disconnect the loader harness connector (Item 1) [Figure 80-30-9].

Figure 80-30-10

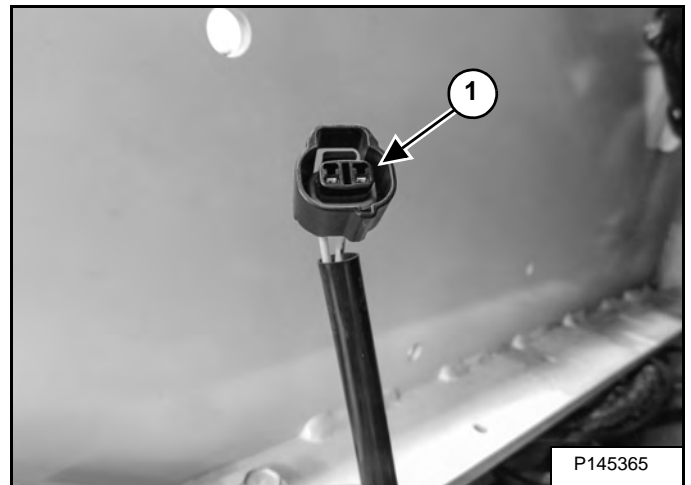

Using a multimeter test the loader wiring harness connector (Item 1) [Figure 80-30-10] for voltage.

The voltage should be around 12 volts.

If there is no voltage at the wiring harness, inspect the harness for broken wires.

Figure 80-30-11

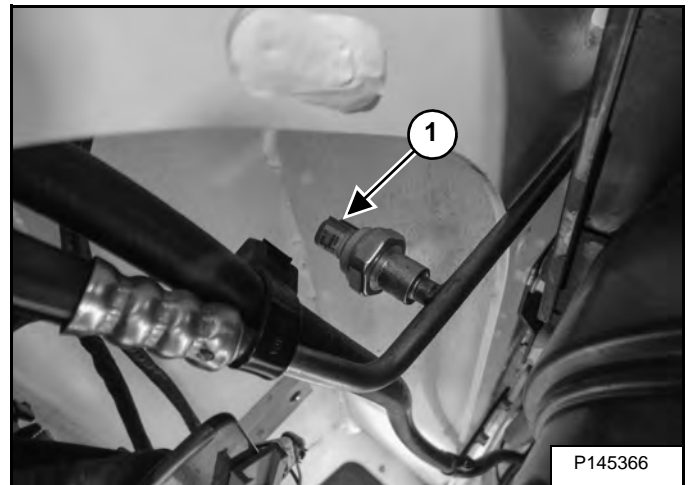

If there is voltage at the harness, test the resistance at the pressure switch (Item 1) [Figure 80-30-11].

If there is no resistance value, inspect for low refrigerant level. (See Reclamation And Charging With Recovery / Charging Unit on Page 80-40-2.)

If a resistance value is seen, the pressure switch is good.

Reconnect the loader harness to the pressure switch.

SYSTEM CHARGING AND RECLAMATION (CONT'D)

Reclamation And Charging With Recovery / Charging Unit (Cont'd)

Figure 80-40-4

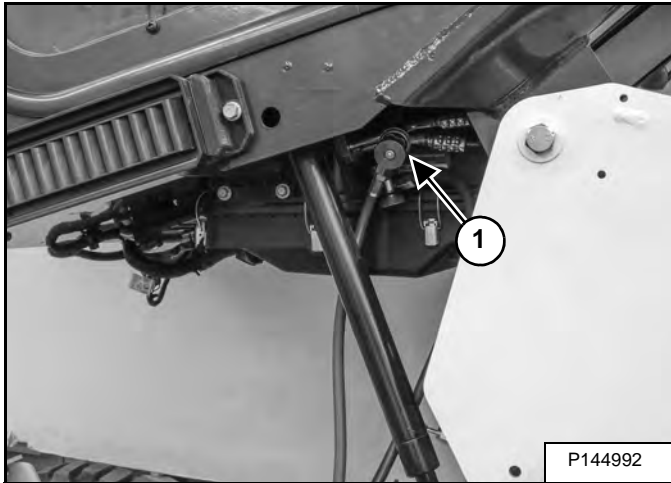
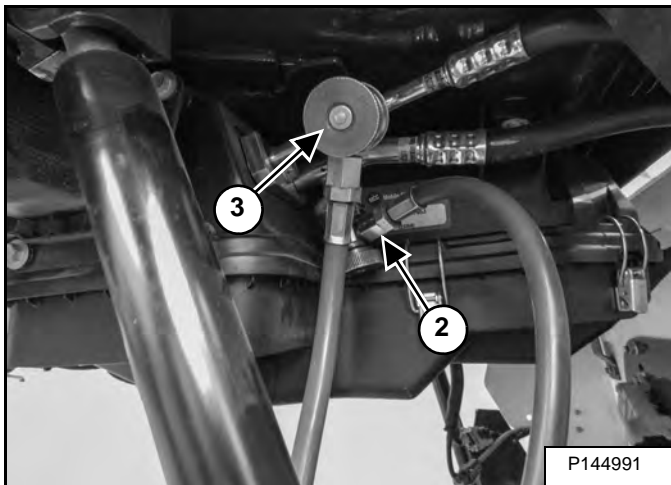

Figure 80-40-5



Connect the reclaimer to the loader A/C charge ports (Item 1) [Figure 80-40-4].

Connect the Blue hose (Item 2) [Figure 80-40-5] to the low pressure port and open the valve.

Connect the Red hose (Item 3) [Figure 80-40-5] to the high pressure port and open the valve.

Figure 80-40-6

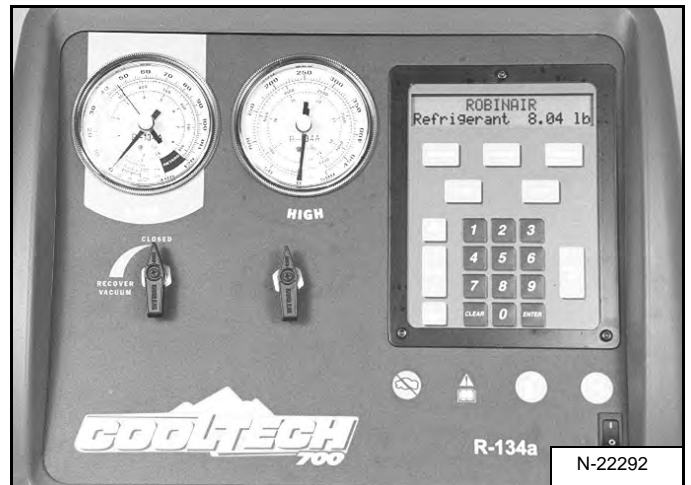

Turn the reclaimer unit [Figure 80-40-6] to the ON position and follow the on screen instructions.

NOTE: For the correct quantity of refrigerant. (See Fluid Capacities on Page SPEC-10-6.)

Figure 80-40-7

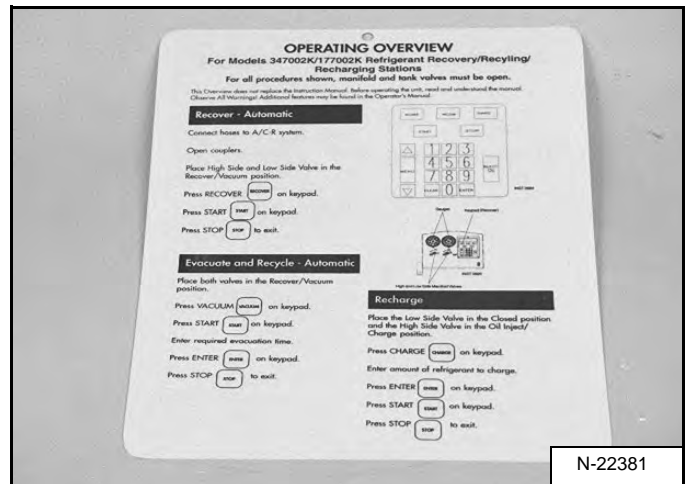

NOTE: The reclaimer unit, has a complete step by step set of instructions [Figure 80-40-7] to follow for reclamation and recharging of the A/C system. A trained technician should follow these instructions as they may vary slightly depending on the model and brand of reclaimer used.

EVAPORATOR / HEATER UNIT

Removal And Installation

Raise the lift arms and install an approved lift arm support device. (See Installing Lift Arm Support Device on Page 10-20-1.)

Raise the operator cab. (See Raising Operator Cab on Page 10-30-2.)

Evacuate the A/C system. (See Reclamation And Charging With Recovery / Charging Unit on Page 80-40-2.)

Figure 80-80-1

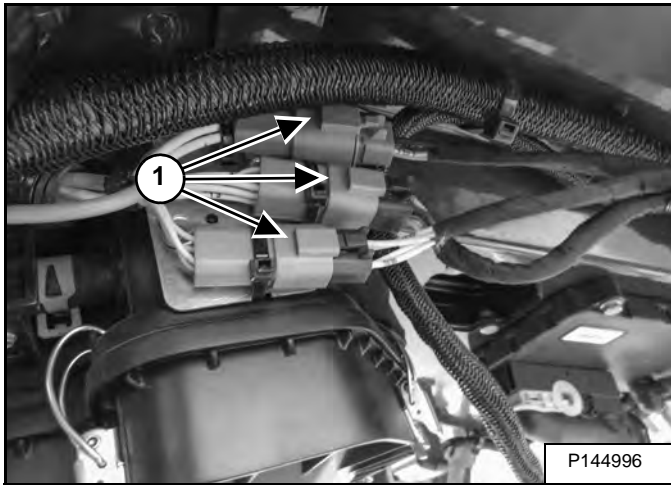

Disconnect the wiring harness connectors (Item 1) [Figure 80-80-1].

Figure 80-80-2

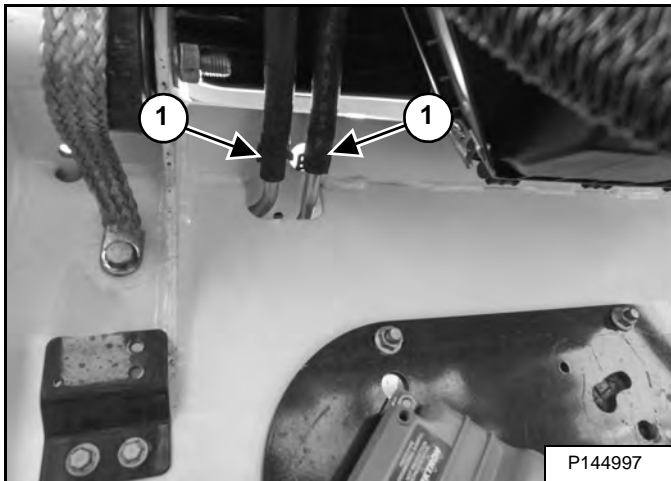

NOTE: Cap the heater hoses and the tubelines with plugs to prevent coolant loss from the system.

Remove the two hoses (Item 1) [Figure 80-80-2].

Figure 80-80-3

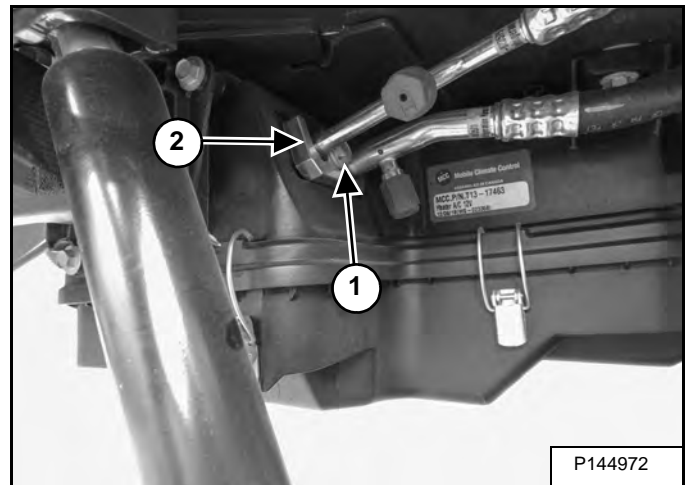

Remove the bolt (Item 1) and the tubeline assembly (Item 2) [Figure 80-80-3].

Cap and plug the hoses and the expansion valve fittings with the proper A/C caps and plugs.

NOTE: Always replace O-rings and lube with compressor oil. Care must be taken not to damage O-rings when installing the hose fittings.

Figure 80-80-4

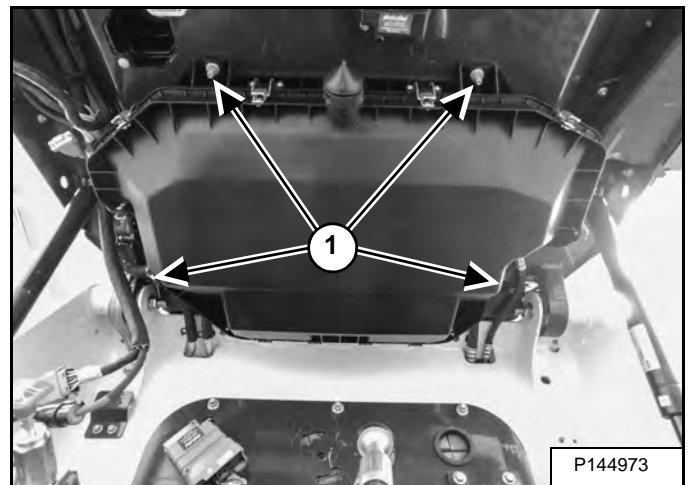

NOTE: Support the evaporator / heater unit before removing the mounting hardware.

Remove the nuts (Item 1) [Figure 80-80-4].

Remove evaporator / heater unit from the loader.

EVAPORATOR COIL

Removal And Installation

Raise the lift arms and install an approved lift arm support device. (See Installing Lift Arm Support Device on Page 10-20-1.)

Raise the operator cab. (See Raising Operator Cab on Page 10-30-2.)

Evacuate the A/C system. (See Reclamation And Charging With Recovery / Charging Unit on Page 80-40-2.)

WARNING

In the event of a leak, wear safety goggles. Escaping refrigerant can cause severe injuries to eyes. In contact with a flame, R-134a refrigerant gives a toxic gas.

W-2371-0611

Figure 80-110-17

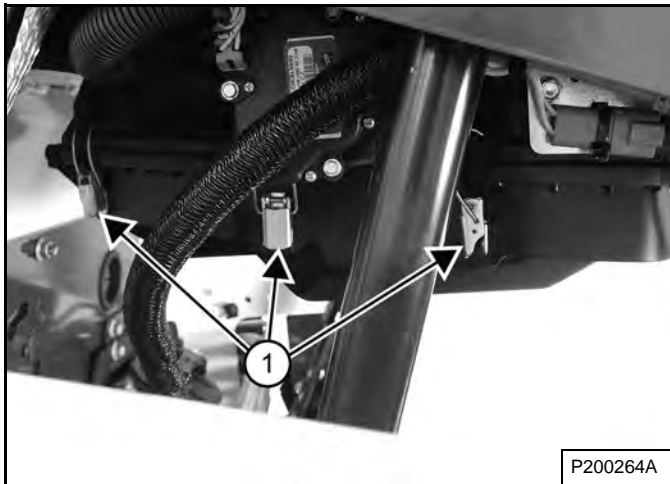

Unhook three cover latches (Item 1) [Figure 80-110-17] on the right side of the HVAC cover.

Figure 80-110-18

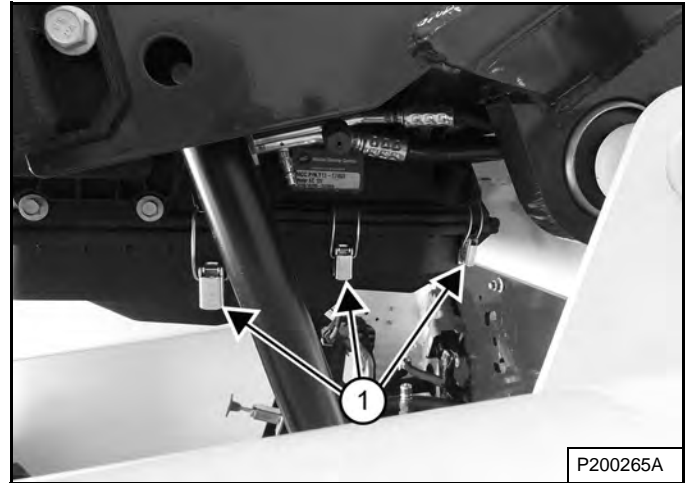

Unhook three cover latches (Item 1) [Figure 80-110-18] on the left side of the HVAC cover.

Figure 80-110-19

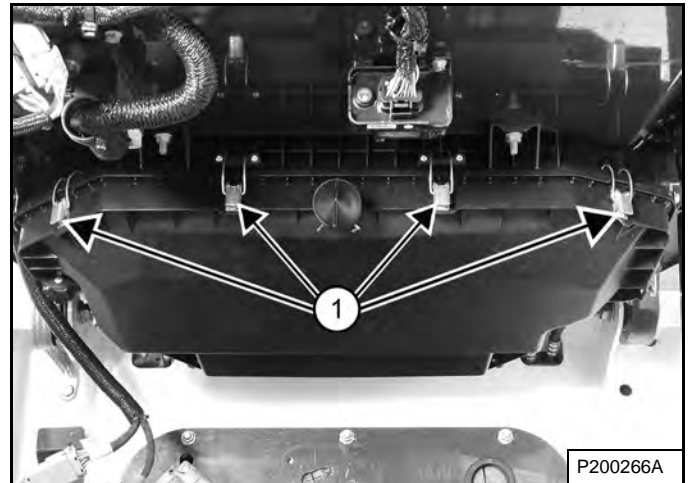

Unhook four cover latches (Item 1) [Figure 80-110-19] on the front side of the HVAC cover.

HEATER VALVE

Removal And Installation

Raise the lift arms and install an approved lift arm support device. (See Installing Lift Arm Support Device on Page 10-20-1.)

Raise the operator cab. (See Raising Operator Cab on Page 10-30-2.)

NOTE: The heater valve is not serviceable and must be replaced as a complete assembly.

Remove any tie straps that hold the heater hoses.

NOTE: The evaporator / heater unit is shown removed for photo clarity.

NOTE: Cap the heater hoses and the heater valve with plugs to prevent coolant loss from the system.

Figure 80-140-1

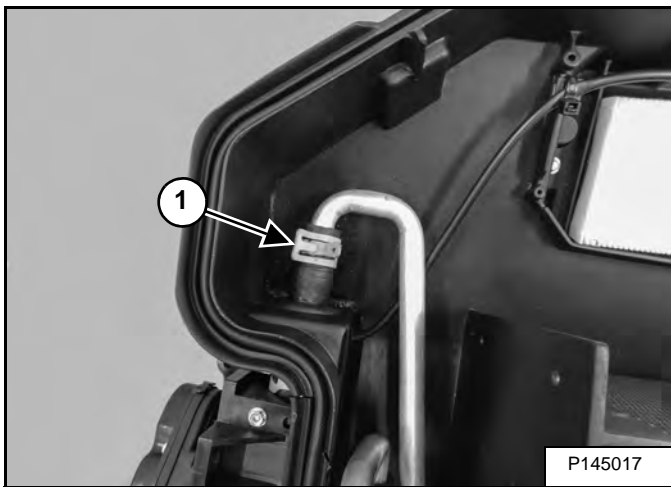

Remove the hose clamp (Item 1) [Figure 80-140-1].

Figure 80-140-2

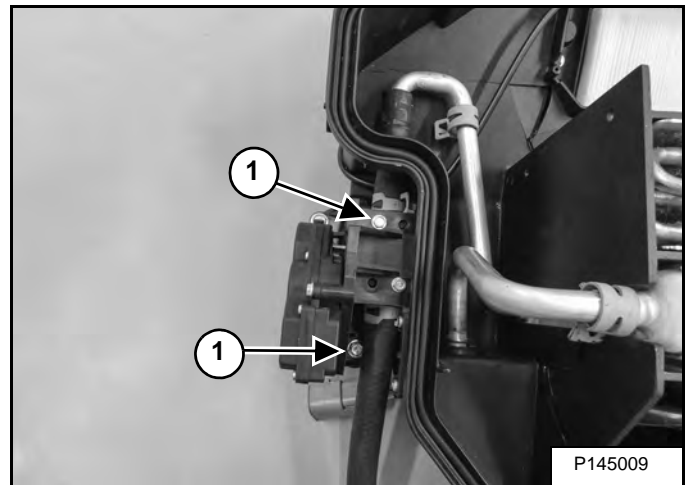

Remove the two screws (Item 1) [Figure 80-140-2].

Remove the heater valve from the evaporator / heater unit.

Figure 80-140-3

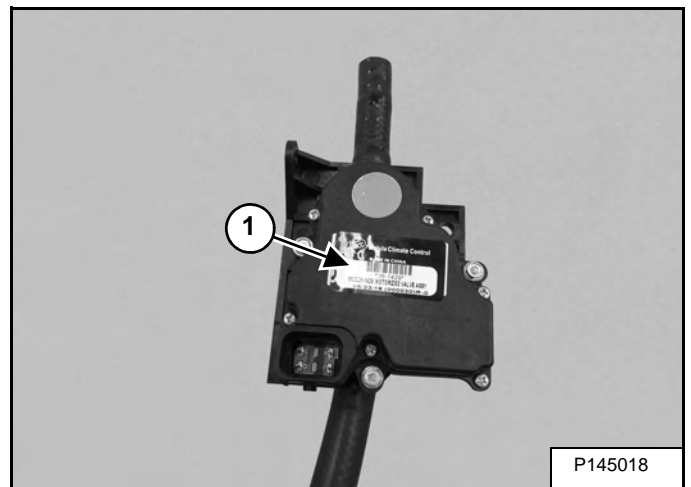

Heater valve (Item 1) [Figure 80-140-3] removed from the evaporator / heater unit.

LOADER SPECIFICATIONS (CONT'D)

Hydraulic System Specifications

Pump Type	Engine driven, gear type
Pump Capacity – Standard-Flow	88,1 L/min (23.3 U.S. gpm)
Pump Capacity – High-Flow	114,7 L/min (30.3 U.S. gpm)
System Relief at Quick Couplers	23,8 – 24,5 MPa (238 – 245 bar) (3450 – 3550 psi)
Filter (Main Hydraulic)	Replaceable β 10(c) \geq 200 ISO 16889, drop in element
Filter (Charge)	Replaceable β 12(c) \geq 200 ISO 16889, spin on element
Filter (Case Drain)	Replaceable β 20(c) \geq 200 ISO 16889, spin on element
Filter (Hydraulic Reservoir Vent)	Replaceable 10 micron, thread on cap
Control Valve	3-Spool, open center with electric actuator controlled lift with float and tilt; Electro-hydraulic piloted auxiliary spool
Fluid Lines	SAE Standard tubelines, hoses, and fittings
Fluid Type	BOBCAT FLUID, Hydraulic / Hydrostatic 6903117 – (Two – 2.5 U.S. gal) 6903118 – (5 U.S. gal) 6903119 – (55 U.S. gal)
Hydraulic Function Time:	
Raise Lift Arms	4.3 seconds
Lower Lift Arms	2.9 seconds
Bucket Dump	2.1 seconds
Bucket Rollback	1.6 seconds

Hydraulic Cylinder Specifications

Double-acting; lift cylinders have cushioning feature on lower, tilt cylinders have cushioning feature on dump and rollback	BORE	STROKE	ROD
Lift	76,2 mm (3.00 in)	648,5 mm (28.53 in)	44,5 mm (1.97 in)
Tilt	76,2 mm (3.00 in)	344,4 mm (13.56 in)	38,1 mm (1.50 in)

CONVERSIONS

Decimal And Millimeter Equivalent Chart

FRACTIONS	DECIMALS	MM	FRACTIONS	DECIMALS	MM	
	1/64 —	0.015625 —	0.397	33/64 —	0.515625 —	13.097
1/32 —	0.03125 —	0.794	17/32 —	0.53125 —	13.494	
	3/64 —	0.046875 —	1.191	35/64 —	0.546875 —	13.891
1/16 —	0.0625 —	1.588	9/16 —	0.5625 —	14.288	
	5/64 —	0.078125 —	1.984	37/64 —	0.578125 —	14.684
3/32 —	0.09375 —	2.381	19/32 —	0.59375 —	15.081	
	7/64 —	0.109375 —	2.778	39/64 —	0.609375 —	15.478
1/8 —	0.1250 —	3.175	5/8 —	0.6250 —	15.875	
	9/64 —	0.140625 —	3.572	41/64 —	0.640625 —	16.272
5/32 —	0.15625 —	3.969	21/32 —	0.65625 —	16.669	
	11/64 —	0.171875 —	4.366	43/64 —	0.671875 —	17.066
3/16 —	0.1876 —	4.762	11/16 —	0.6875 —	17.462	
	13/64 —	0.203125 —	5.159	45/64 —	0.703125 —	17.859
7/32 —	0.21875 —	5.556	23/32 —	0.71875 —	18.256	
	15/64 —	0.234375 —	5.953	47/64 —	0.734375 —	18.653
1/4 —	0.2500 —	6.350	3/4 —	0.7500 —	19.050	
	17/64 —	0.265625 —	6.747	49/64 —	0.765625 —	19.447
9/32 —	0.28125 —	7.144	25/32 —	0.78125 —	19.844	
	19/64 —	0.296875 —	7.541	51/64 —	0.796875 —	20.241
5/16 —	0.3125 —	7.938	13/16 —	0.8125 —	20.638	
	21/64 —	0.328125 —	8.334	53/64 —	0.828125 —	21.034
11/32 —	0.34375 —	8.731	27/32 —	0.84375 —	21.431	
	23/64 —	0.359375 —	9.128	55/64 —	0.859375 —	21.828
3/8 —	0.3750 —	9.525	7/8 —	0.8750 —	22.225	
	25/64 —	0.390625 —	9.922	57/64 —	0.890625 —	22.622
13/32 —	0.40625 —	10.319	29/32 —	0.90625 —	23.019	
	27/64 —	0.421875 —	10.716	59/64 —	0.921875 —	23.416
7/16 —	0.4375 —	11.112	15/16 —	0.9375 —	23.812	
	29/64 —	0.453125 —	11.509	61/64 —	0.953125 —	24.209
15/32 —	0.46875 —	11.906	31/32 —	0.96875 —	24.606	
	31/64 —	0.484375 —	12.303	63/64 —	0.984375 —	25.003
1/2 —	0.5000 —	12.700	1 —	1.000 —	25.400	

1 mm = 0.03937"

0.001 = 0.0254 mm

U.S. To Metric Conversion Chart

	TO CONVERT	INTO	MULTIPLY BY
LINEAR MEASUREMENT	Miles	Kilometers	1.609
	Yards	Meters	0.9144
	Feet	Meters	0.3048
	Feet	Centimeters	30.48
	Inches	Meters	0.0254
	Inches	Centimeters	2.54
	Inches	Millimeters	25.4
AREA	Square Miles	Square Kilometers	2.59
	Square Feet	Square Meters	0.0929
	Square Inches	Square Centimeters	6.452
	Acre	Hectare	0.4047
VOLUME	Cubic Yards	Cubic Meters	0.7646
	Cubic Feet	Cubic Meters	0.02832
	Cubic Inches	Cubic Centimeters	16.39
WEIGHT	Tons (Short)	Metric Tons	0.9078
	Pounds	Kilograms	0.4536
	Ounces (Avdp.)	Grams	28.3495
PRESSURE	Pounds/Sq. In.	Kilopascal	6.895
WORK	Foot-Pounds	Newton-Meter	1.356
LIQUID VOLUME	Quarts	Liters	0.9463
	Gallons	Liters	3.785
LIQUID FLOW	Gallons/Minute	Liters/Minute	3.785
TEMPERATURE	Fahrenheit	Celsius	1. Subtract 32°
			2. Multiply by 5/9

SERVICE TOOLS REQUIRED (CONT'D)

Engine Tools

TOOL PART NUMBER	DESCRIPTION	MODELS USED ON	COMMENT	IMAGE
7024161	Diagmaster Kit (iT4 engine only)	S750 - S850 T750 - T870 A770	Includes: DST-i (Diagmaster Service Tool) Vehicle cable (7024272) USB cable (7024271) Diagmaster Diagnostic Software.	
MEL10630	Engine Compression Test Kit	S70,S100, T110 S450 - S650, T450 - T650	Includes: MEL1352, MEL1433, MEL1489, MEL1546, MEL1551, MEL1594, MEL1594, MEL10630-1 - MEL10630-11 and MEL10630-14	
MEL1655	Compression Adapter	S450 - S650 T550 - T650	Used in glow plug port for testing compression, NOT included with MEL10630. Kubota V2607 and V3307 engines.	
MEL1614	Compression Adapter	S750 - S850 T750 - T870 A770	Used in injector port for testing compression, NOT included with MEL10630. Kubota V3300 and V3800 engines.	
MEL1656	Fuel Injection Pump Degree Restoring Tool			
MEL1657	Timing Gear Puller Tool			
7031222	Bobcat Engine Analyzer Diagnostic Tool Kit	T4 Bobcat Engine Applications	Includes: Diagnostic Service Tool (7031223), Vehicle Cable 6 pin (7031398), Vehicle Cable 14 pin (7031356), USB Cable (7031357)	
7031370	Rear Main Seal Installer	Bobcat 1.8L & 2.4L Engine Models Tier 4	Used for installing rear main seal.	
7031369	Front Seal Installer	T4 Bobcat Engine Applications	Used for installing front seal.	

See BobcatDealerNET.com for parts ordering information. (For EMEA dealers see the Bobcat Special Tools Catalogue and Doosan Shop for parts ordering information.)

ST LDR-0820

CLICK HERE TO **DOWNLOAD** THE COMPLETE MANUAL

- Thank you very much for reading the preview of the manual.
- You can download the complete manual from: www.heydownloads.com by clicking the link below



- Please note: If there is no response to CLICKING the link, please download this PDF first and then click on it.

CLICK HERE TO **DOWNLOAD** THE COMPLETE MANUAL