



# Bobcat®

---

## Service Manual

# S650 Skid-Steer Loader

---

S/N A3NV11001 & Above  
S/N A3NW11001 & Above

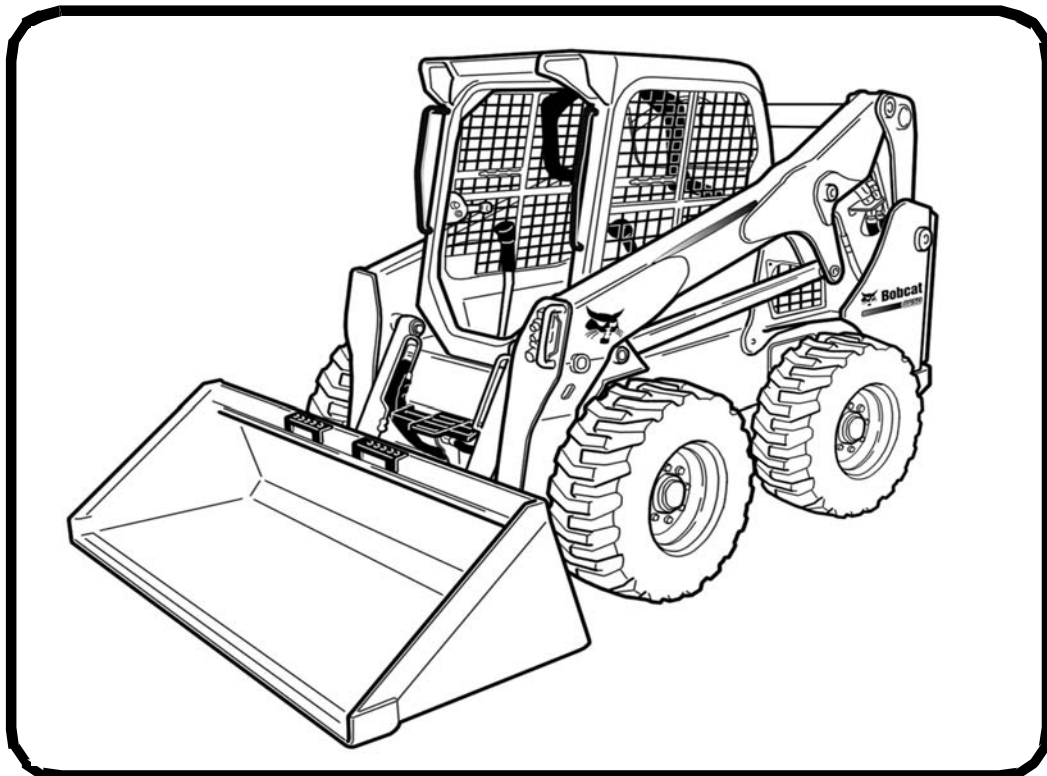

EQUIPPED WITH  
BOBCAT INTERLOCK  
CONTROL SYSTEM (BICS™)

6987168 (10-10)

Printed in U.S.A.



© Bobcat Company 2010

CLICK HERE TO **DOWNLOAD** THE COMPLETE MANUAL

- Thank you very much for reading the preview of the manual.
- You can download the complete manual from: [www.heydownloads.com](http://www.heydownloads.com) by clicking the link below



- Please note: If there is no response to CLICKING the link, please download this PDF first and then click on it.

CLICK HERE TO **DOWNLOAD** THE COMPLETE MANUAL



**Bobcat®**

EMERGENCY EXIT .....	10-210-1
External Access .....	10-210-1
Rear Window .....	10-210-1
Front Door .....	10-210-1
SEAT BELT .....	10-220-1
Inspection And Maintenance .....	10-220-1

## TRANSPORTING LOADER ON A TRAILER

### Loading And Unloading



#### AVOID SERIOUS INJURY OR DEATH

Adequately designed ramps of sufficient strength are needed to support the weight of the machine when loading onto a transport vehicle. Wood ramps can break and cause personal injury.

W-2058-0807

Be sure the transport and towing vehicles are of adequate size and capacity for weight of loader. (See Performance on Page SPEC-10-2.)

Figure 10-40-1



A loader with an empty bucket or no attachment must be loaded backward onto the transport vehicle [Figure 10-40-1].

The rear of the trailer must be blocked or supported (Item 1) [Figure 10-40-1] when loading or unloading the loader to prevent the front end of the trailer from raising up.

## Fastening

Figure 10-40-2

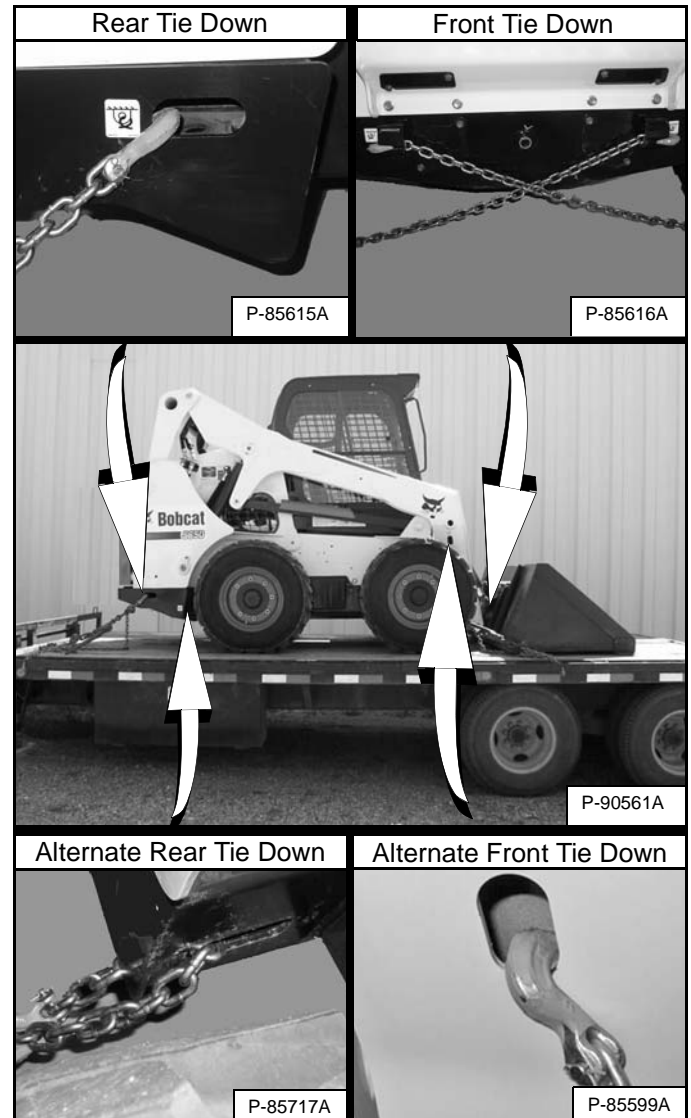

Use the following procedure to fasten the Bobcat loader to the transport vehicle to prevent the loader from moving during sudden stops or when going up or down slopes [Figure 10-40-2].

1. Lower the bucket or attachment to the floor.
2. Stop the engine.
3. Engage the parking brake.
4. Install chains at the front and rear loader tie down positions [Figure 10-40-2]. (Lift arms shown raised for clarity.)
5. Fasten each end of the chain to the transport vehicle.
6. Use chain binders to tighten the chains.

## **REMOTE START TOOL (SERVICE TOOL) KIT - 7003031**

### **Description**

The Remote Start Tool (Service Tool) Kit is a replacement tool for MEL 1563 Remote Start Tool and MEL 1400B - BOSS® Diagnostic Tool.

The Remote Start Tool (Service Tool) Kit, P/N 7003031, can be used to service newer loaders using the supplied harness P/N 6689747.

A computer can be connected to the Remote Start Tool (Service Tool) for diagnostics and software updates using the computer harness P/N 6689746 in conjunction with the loader harness.

## AIR CLEANER SERVICE

### Replacing Filter Elements

Figure 10-80-1

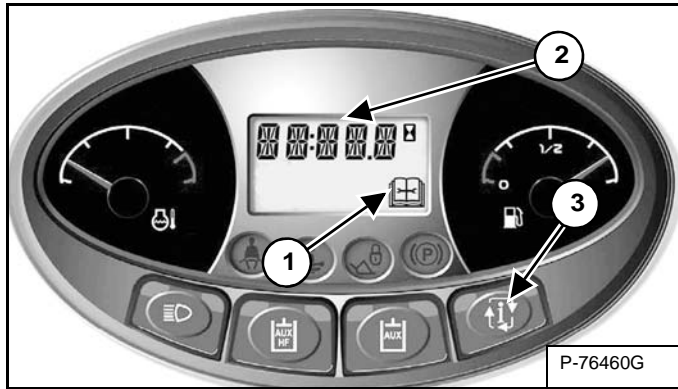

It is important to change the air filter element only when necessary. The service indicator (Item 1) will FLASH. Press the information button (Item 3) until the display screen (Item 2) shows the service codes. Service code **[M0117]** (Air Filter Plugged) will show in the display screen (Item 2) **[Figure 10-80-1]** when air filter change is necessary.

Replace the inner filter every third time the outer filter is replaced or as indicated.

### Outer Filter

Figure 10-80-2

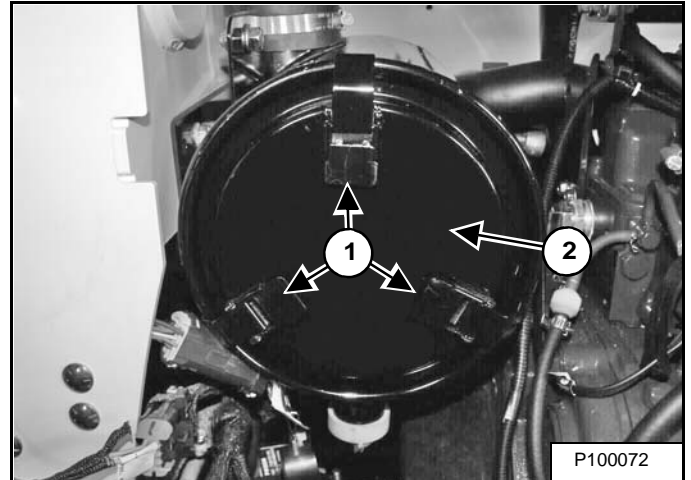

Open the latches (Item 1) and remove the dust cover (Item 2) **[Figure 10-80-2]**.

Figure 10-80-3

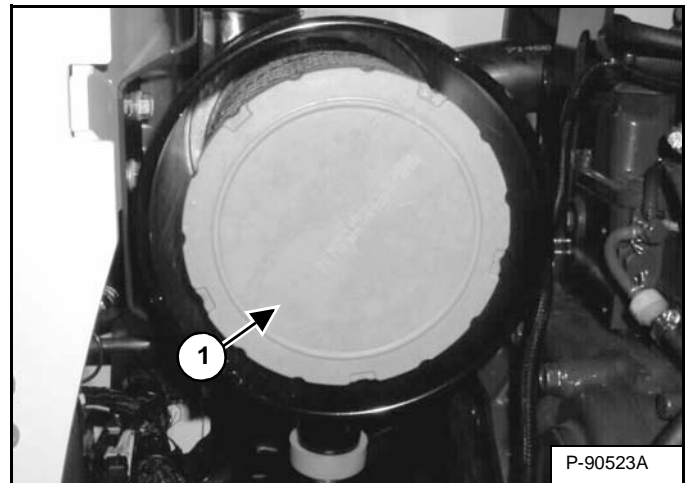

Pull the outer filter element (Item 1) **[Figure 10-80-3]** out and discard.

**NOTE: Make sure all sealing surfaces are free of dirt and debris. DO NOT use compressed air.**

Install new filter element. Push all the way in until it contacts the base of the housing.

Install the dust cover and secure the latches **[Figure 10-80-2]**.

## ENGINE LUBRICATION SYSTEM

### Checking And Adding Engine Oil

Check the engine oil level every day before starting the engine for the work shift.

Figure 10-110-1

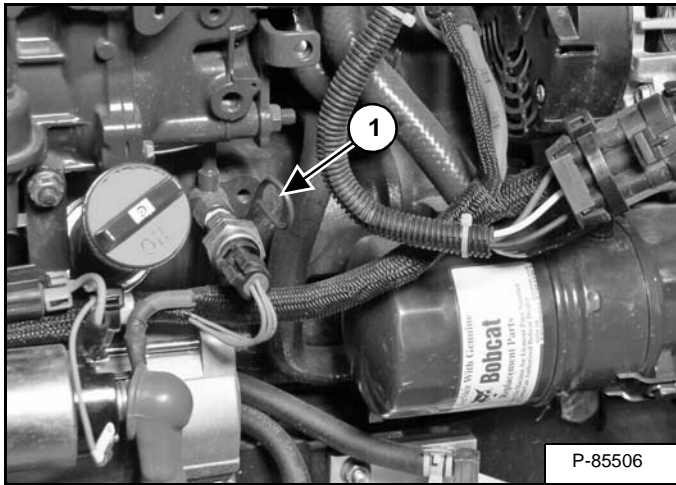

Park the machine on level ground. Open the rear door and remove the dipstick (Item 1) [Figure 10-110-1].

Keep the oil level between the marks on the dipstick. Do not overfill.

## Engine Oil Chart

Figure 10-110-2

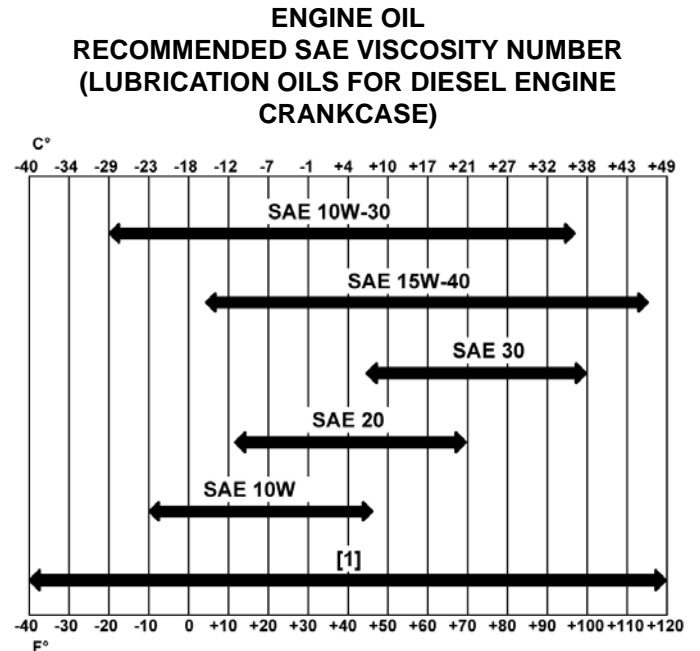

**TEMPERATURE RANGE ANTICIPATED BEFORE  
NEXT OIL CHANGE (DIESEL ENGINES MUST USE API  
CLASSIFICATION CI-4 OR BETTER)**

[1] Synthetic Oil - Use recommendation from Synthetic Oil Manufacturer.

Use good quality engine oil that meets API Service Classification of CI-4 or better [Figure 10-110-2].



### AVOID INJURY OR DEATH

Always clean up spilled fuel or oil. Keep heat, flames, sparks or lighted tobacco away from fuel and oil. Failure to use care around combustibles can cause explosion or fire.

W-2103-0508

## FINAL DRIVE TRANSMISSION (CHAINCASE)

### Checking And Adding Oil

The chaincase contains the final drive sprockets and chains and uses the same type of oil as the hydraulic / hydrostatic system. (See Hydraulic System on Page SPEC-10-3.)

Stop the loader on a level surface and stop the engine.

**Figure 10-130-1**

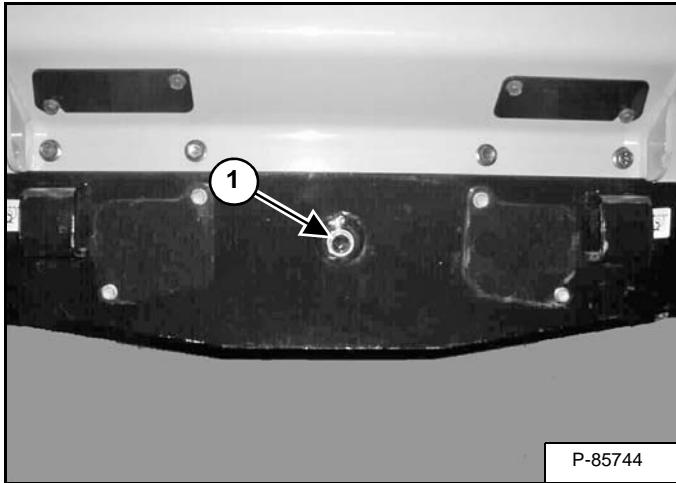

Remove the check plug (Item 1) [Figure 10-130-1] from the front of the chaincase housing. (Lift arms shown raised for clarity.)

If oil can be reached with the tip of your finger through the hole, the oil level is correct.

If the level is low, add oil through the check plug hole until the oil flows from the hole.

Install and tighten the plug.

## Removing And Replacing Oil

**Figure 10-130-2**

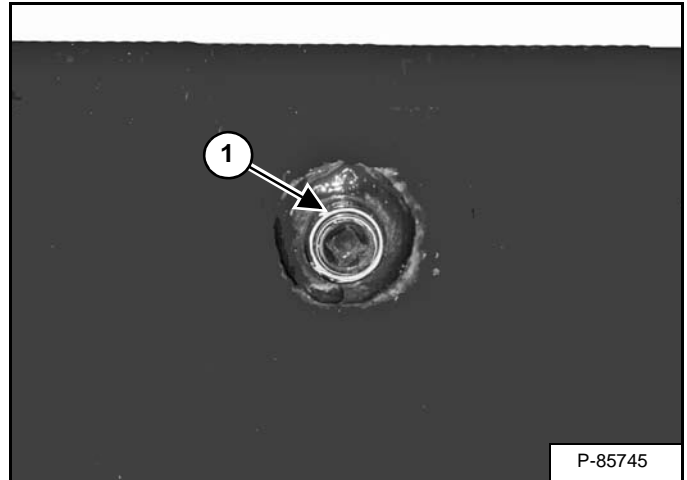

Remove the check plug (Item 1) [Figure 10-130-2] from the front of the chaincase housing.

**Figure 10-130-3**

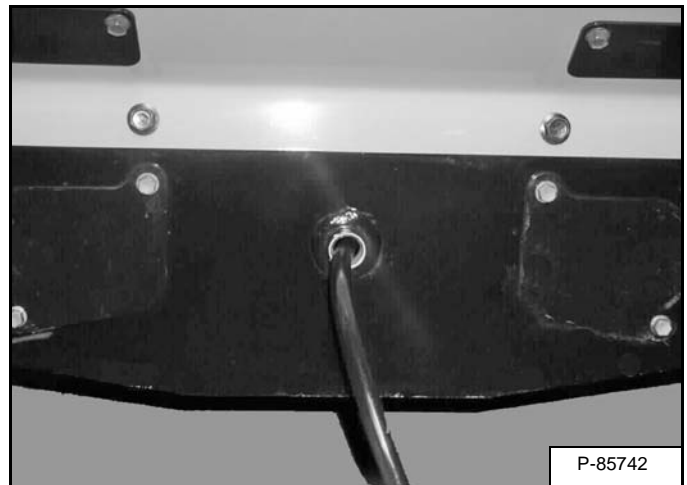

Pump the oil out of the chaincase [Figure 10-130-3].

Recycle or dispose of the used oil in an environmentally safe manner.

Add oil through the check plug hole until the oil flows from the hole.

**! WARNING**

### AVOID INJURY OR DEATH

Always clean up spilled fuel or oil. Keep heat, flames, sparks or lighted tobacco away from fuel and oil. Failure to use care around combustibles can cause explosion or fire.

W-2103-0508

## TIRE MAINTENANCE

### Wheel Nuts

Figure 10-160-1



See your SERVICE SCHEDULE for the correct interval to check the wheel nuts [Figure 10-160-1]. (See SERVICE SCHEDULE on Page 10-70-1.)

When *installing* wheel nuts, tighten to 217 N•m (160 ft-lb) torque.

When *checking* wheel nut torque, set the torque wrench to 190 N•m (140 ft-lb) to prevent over-tightening.

### Rotating

Check the tires regularly for wear, damage and pressure.

Figure 10-160-2

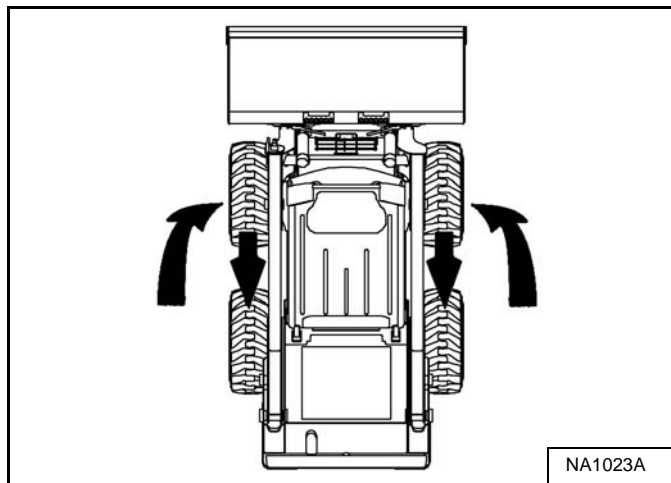

Rear tires usually wear faster than front tires. To keep tire wear even, move the front tires to the rear and rear tires to the front [Figure 10-160-2].

It is important to keep the same size tires on each side of the loader. If different sizes are used, each tire will be turning at a different rate and cause excessive wear. The tread bars of all the tires must face the same direction.

Recommended tire pressure must be maintained to avoid excessive tire wear and loss of stability and handling capability. Check for correct pressure before operating the loader.

### Mounting

Tires are to be repaired only by an authorized person using the proper procedures and safe equipment.

Tires and rims must always be checked for correct size before mounting. Check rim and tire bead for damage.

The rim flange must be cleaned and free of rust.

The tire bead and rim flange must be lubricated with a rubber lubricant before mounting the tire.

Avoid excessive pressure which can rupture the tire and cause serious injury or death.

During inflation of the tire, check the tire pressure frequently to avoid over inflation.

## WARNING

### AVOID INJURY OR DEATH

Do not inflate tires above specified pressure. Failure to use correct tire mounting procedure can cause an explosion which can result in injury or death.

W-2078-1007

## IMPORTANT

Inflate tires to the MAXIMUM pressure shown on the sidewall of the tire. DO NOT mix brands of tires used on the same loader.

I-2057-0794

## EMERGENCY EXIT

The front opening on the operator cab and rear window provide exits.

### External Access

Figure 10-210-1

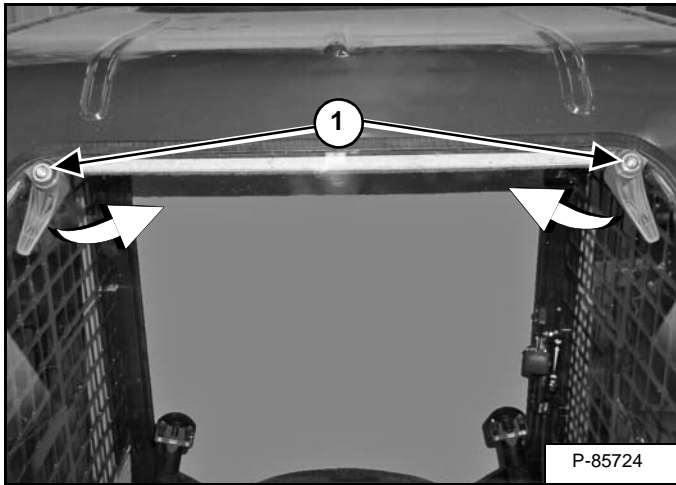

The rear window can be removed from outside the loader using a T40 TORX® driver. Turn both screws (Item 1) [Figure 10-210-1] in until the latches disengage from the window frame. Pull the top of the window away from the cab and lift up to remove.

### Rear Window

**NOTE:** Use this procedure to remove the rear window only under emergency conditions. Damage to machine may occur.

Figure 10-210-2

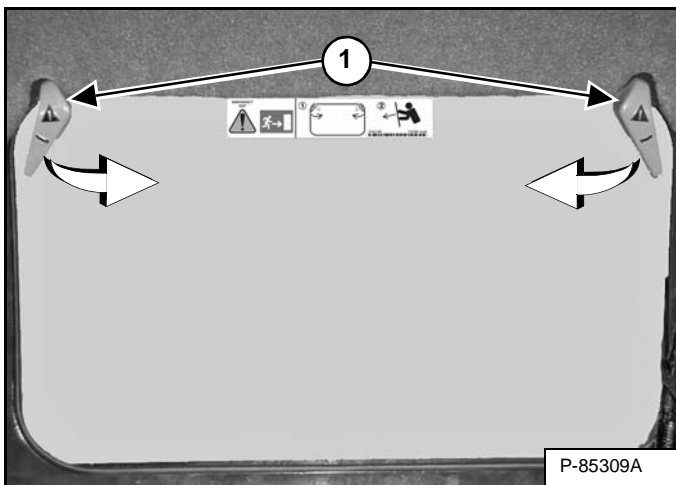

Turn both latches (Item 1) [Figure 10-210-2] in until they disengage from the window frame.

Push the rear window out of the rear of the operator cab.

Figure 10-210-3



Exit through the rear of the operator cab [Figure 10-210-3].

### Front Door

This machine may be equipped with a front door.

**NOTE:** Use this procedure to remove the front door only under emergency conditions. Damage to machine may occur.

Figure 10-210-4

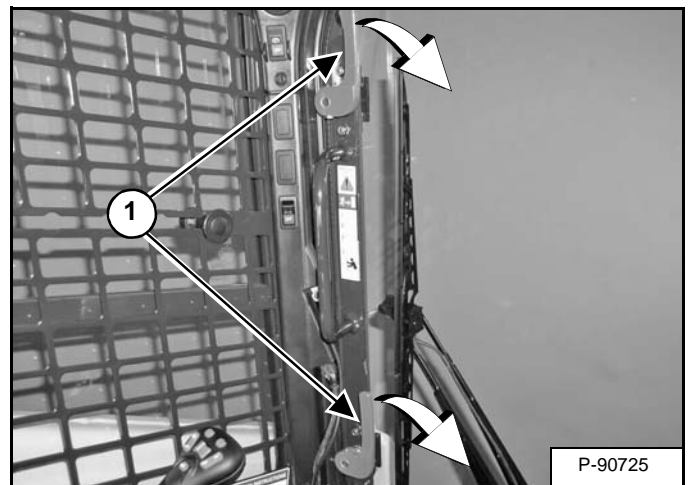

Turn both latches (Item 1) [Figure 10-210-4] down until they disengage from the door frame.

Push the door out of the operator cab door frame.

Exit through the opening.

# HYDRAULIC/HYDROSTATIC SCHEMATIC WITH ALL OPTIONS

## S650 (S/N A3NV11001 AND ABOVE) (S/N A3NW11001 AND ABOVE)

(PRINTED JUNE 2009)

V-1349legend

### LEGEND

- |  |  |   |   |
|--|--|---|---|
| <p>① RESERVOIR:<br/>Capacity at sight gauge . . . 10.7 Qts. (10,2 L)<br/>System Capacity . . . . . 10.5 Gal. (39,7 L)</p> <p>② SIGHT GUAGE</p> <p>③ DIFFERENTIAL PRESSURE SWITCH:<br/>15 PSI (1,07 bar)<br/>Normally Closed</p> <p>④ FILTER - HYDRAULIC (CANISTER)</p> <p>⑤ SPRING LOADED FILTER BY-PASS VALVE: 25 PSI (1,7 bar)</p> <p>⑥ DIAGNOSTIC COUPLER</p> <p>⑦ RELIEF VALVE - MAIN:<br/>3500 PSI (241 bar)<br/>at Front Quick Couplers</p> <p>⑧ RELIEF/ANTICAVITATION VALVE - PORT 4000 PSI (276 bar)</p> <p>⑨ RELIEF/ANTICAVITATION VALVE - PORT (OPTIONAL) 4000 PSI (276 bar)</p> <p>⑩ SOLENOID ACTIVATED DIRECTIONAL CONTROL VALVE - AUXILIARY</p> <p>⑪ LOAD CHECK VALVE</p> <p>⑫ FRONT AUXILIARY MANUAL PRESSURE BLEED-OFF VALVE</p> <p>⑬ PILOTED ACTIVATED DIRECTIONAL CONTROL VALVE - TILT CONTROL</p> <p>⑭ PILOTED ACTIVATED DIRECTIONAL CONTROL VALVE - LIFT CONTROL</p> <p>⑮ SOLENOID ACTIVATED DIRECTIONAL CONTROL VALVE - BICS CONTROL</p> <p>⑯ FILTER - BICS CONTROL VALVE (SCREEN)</p> <p>⑰ CHECK VALVE - With 14.5 PSI (1,0 bar) Spring</p> <p>⑱ RESTRICTION . . . . . 0.079 in. (2,0 mm)</p> | <p>⑲ PULL BUTTON ACTIVATED DIRECTIONAL CONTROL VALVE - LIFT ARM BY-PASS</p> <p>⑳ LIFT CYLINDER SPOOL - MADE TO RESTRICT FLOW DURING BOOM DOWN BUT NOT DURING BOOM UP</p> <p>㉑ ANTICAVITATION VALVE</p> <p>㉒ PROPORTIONAL RELIEF VALVE – (Fan Speed Regulator):<br/>1566 - 1784 PSI (108 - 123 bar)</p> <p>㉓ SPRING LOADED FILTER BY-PASS VALVE: 75 - 83 PSI (5,2 - 5,7 bar)</p> <p>㉔ FIXED CAPACITY DISPLACEMENT HYDRAULIC MOTOR</p> <p>㉕ FILTER - HYDRAULIC (CANISTER)</p> <p>㉖ SENSOR – CHARGE PRESSURE – Fan Filter</p> <p>㉗ SOLENOID ACTIVATED DIRECTIONAL CONTROL VALVE - BUCKET POSITION VALVE (ON/OFF)</p> <p>㉘ FLOW DIVIDER ADJUSTMENT VALVE</p> <p>㉙ PILOTED ACTIVATED DIRECTIONAL CONTROL VALVE - FLOW CONTROL SPOOL</p> <p>㉚ CHECK VALVE - BUCKET POSITION VALVE</p> <p>㉛ PILOTED ACTIVATED DIRECTIONAL CONTROL VALVE - UNLOADING SPOOL</p> <p>㉜ PILOT ACTIVATED DIRECTIONAL CONTROL VALVE - HYDRAULIC POWERED BOB-TACH</p> <p>㉝ FILTER - BOB-TACH VALVE</p> <p>㉞ RESTRICTION - 0.089 inch (2,26 mm)</p> <p>㉟ SOLENOID ACTIVATED DIRECTIONAL CONTROL VALVE (TWO COIL)</p> | <p>㊳ RELIEF VALVE - 1200 PSI (83 bar)</p> <p>㊴ CHECK VALVE - With 80 PSI (5,5 bar) Spring</p> <p>㊵ RELIEF VALVE - 2000 PSI (137 bar)</p> <p>㊶ CHECK VALVE - With 300 PSI (20,7 bar) Spring And With 0.016 inch (0,40 mm) Orifice</p> <p>㊷ RESTRICTION - 0.025 inch (0,6 mm)</p> <p>㊸ SENSOR – HYD. TEMPERATURE</p> <p>㊹ HYDRAULIC PUMP . . . . . Gear Type 23.0 GPM (87,1 L/min.) at High Engine Idle</p> <p>㊺ CHARGE PUMP - 13.5 GPM (51,1 L/min) at High Engine Idle</p> <p>㊻ PILOT ACTIVATED DIRECTIONAL CONTROL VALVE - REAR AUXILIARY</p> <p>㊼ RELIEF VALVE: 3300 PSI (228 bar)</p> <p>㊽ SOLENOID ACTIVATED DIRECTIONAL CONTROL VALVE - TWO COIL</p> <p>㊾ RESTRICTOR - 0.031 inch (0,8 mm)</p> <p>㊿ LOAD SHUTTLE VALVE - BLEED OFF</p> <p>Ⓚ SOLENOID ACTIVATED DIRECTIONAL CONTROL VALVE - BASE</p> <p>Ⓛ SOLENOID ACTIVATED DIRECTIONAL CONTROL VALVE - ROD</p> <p>Ⓜ VARIABLE CAPACITY DISPLACEMENT BIDIRECTIONAL HYDROSTATIC PUMP</p> <p>Ⓨ RELIEF/REPLENISHING VALVE - HIGH PRESSURE: 5294 PSI (365 bar)</p> <p>Ⓩ RELIEF VALVE - CHARGE INLET:<br/>465 PSI (32, bar)<br/>at High Engine Idle<br/>With 140 degrees F. (60 degrees C.) Fluid</p> <p>ⓐ RESTRICTION - 0.06 inch (1,5 mm)</p> <p>ⓑ CHECK VALVE - With 200 PSI (13,8 bar) Spring</p> <p>ⓒ DRIVE MOTOR SHUTTLE VALVE</p> | <p>ⓓ HIGH PRESSURE SHUTTLE</p> <p>ⓔ FIXED CAPACITY DISPLACEMENT BIDIRECTIONAL HYDROSTATIC MOTOR – 2 SPEED</p> <p>ⓕ FIXED CAPACITY DISPLACEMENT BIDIRECTIONAL HYDROSTATIC MOTOR</p> <p>ⓖ HYDRAULIC BRAKE – SPRING APPLIED – PRESSURE RELEASE (SAPR)</p> <p>ⓗ SOLENOID ACTIVATED DIRECECTIONAL CONTROL VALVE – 2 SPEED</p> <p>ⓘ CHECK VALVE</p> <p>ⓙ SOLENOID ACTIVATED DIRECECTIONAL CONTROL VALVE – MAKE-UP</p> <p>ⓚ FILTER - BRAKE</p> <p>ⓛ SOLENOID ACTIVATED DIRECECTIONAL CONTROL VALVE – BRAKE</p> <p>ⓜ HIGH FLOW HYDRAULIC PUMP Gear Type 7.5 GPM (28,4 L/min.) at High Engine Idle</p> <p>ⓝ RELIEF VALVE - 3500 PSI (241 bar)</p> <p>ⓞ DUMP VALVE – ON / OFF</p> <p>ⓟ CHECK VALVE - With 5.0 PSI (0,34 bar) Spring</p> <p>ⓠ ANTICAVITATION VALVE</p> <p>ⓡ RIDE CONTROL VALVE</p> <p>ⓓ HIGH PRESSURE CHAMBER</p> <p>ⓔ LOW PRESSURE CHAMBER</p> <p>ⓖ FILTER – BOB-TACH VALVE</p> <p>ⓗ CHECK VALVE – COLD WEATHER BY-PASS With 50 PSI (3,45 bar) Spring</p> |
|--|--|---|---|

**NOTE:** Unless otherwise specified springs have NO significant pressure value. V-1349legend (6-8-09)

## HYDRAULIC SYSTEM INFORMATION (CONT'D)

### Troubleshooting

The following troubleshooting chart is provided for assistance in locating and correcting problems which are most common. Many of the recommended procedures must be done by authorized Bobcat Service Personnel only.

If a service code appears in the left instrument panel. (See DIAGNOSTIC SERVICE CODES on Page 60-90-1.)



# WARNING

**Check for correct function after adjustments, repairs or service. Failure to make correct repairs or adjustments can cause injury or death.**

W-2004-1285

PROBLEM	CAUSE
The hydraulic system will not operate.	1, 2, 3, 5, 8
Slow hydraulic system action.	1, 3, 4, 6, 8
Hydraulic action is not smooth.	1, 4, 5, 6, 7
Lift arms go up slowly at full engine RPM	1, 3, 4, 5, 6, 7, 8, 9
The lift arms or Bob-Tach will move when the pedal is in neutral position	4
The lift arms come down when the pedal is in neutral position	4, 9, 10, 11
Lift arm bypass control valve stuck	12
Lift arm bypass control valve stem bent or broken	13

### KEY TO CORRECT CAUSE

1. The fluid level is not correct.
2. The pedal linkage is disconnected.
3. The hydraulic pump has damage.
4. The pedal linkage is not adjusted correctly.
5. Relief valve is not at the correct pressure.
6. Suction leak on the inlet side of the hydraulic pump.
7. Fluid is cold. Wrong viscosity fluid.  
(See HYDRAULIC / HYDROSTATIC FLUID SPECIFICATIONS on Page SPEC-40-1.)
8. Exceeding the loaders rated operating capacity.
9. Internal leak in the lift cylinder(s).
10. External leak from the cylinder(s).
11. Damaged lift spool.
12. Rotate shaft.
13. Replace lift arm bypass control valve assembly.

## CYLINDER (LIFT) (CONT'D)

### Assembly (Cont'd)

Figure 20-20-20

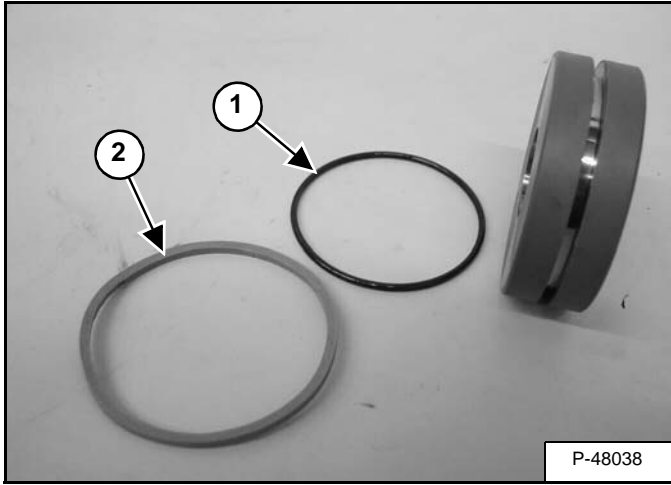

Install the O-ring (Item 1) and seal (Item 2) [Figure 20-20-20] on the cylinder piston.

Figure 20-20-21

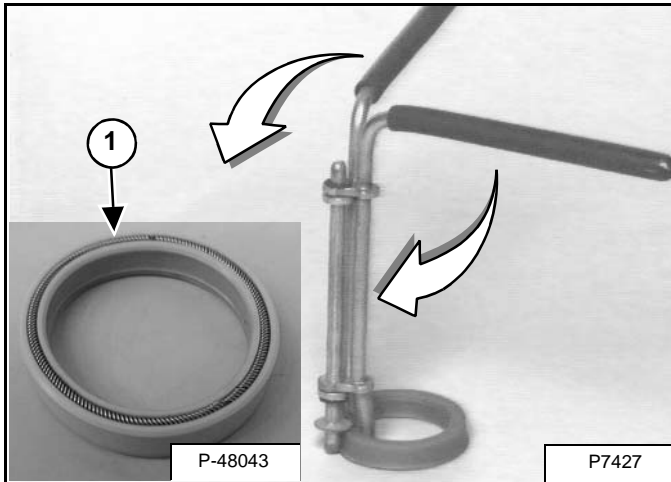

Install the rod seal on the rod seal tool [Figure 20-20-21].

**NOTE:** During installation the spring side of the seal (Item 1) [Figure 20-20-21] must be installed toward the inside of the cylinder.

Rotate the handles to collapse the rod seal [Figure 20-20-21].

Figure 20-20-22

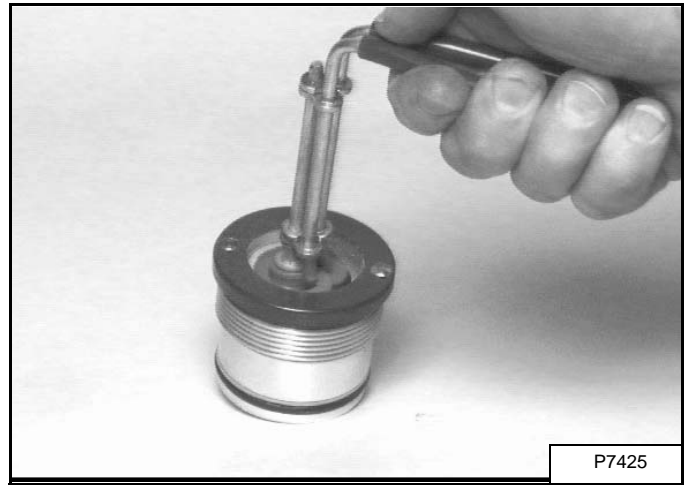

Install the rod seal in the head [Figure 20-20-22].

Figure 20-20-23

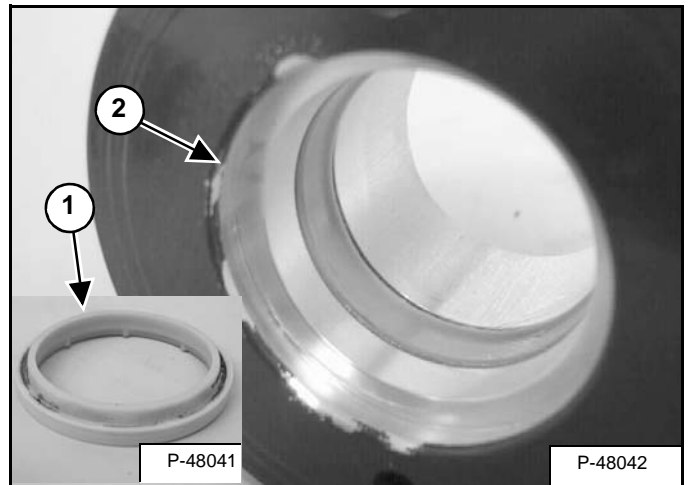

Install the wiper seal, with the wiper side of the seal (Item 1) toward the outside of the head (Item 2) [Figure 20-20-23].

## CYLINDER (TILT) (CONT'D)

### Assembly (Cont'd)

Figure 20-21-21

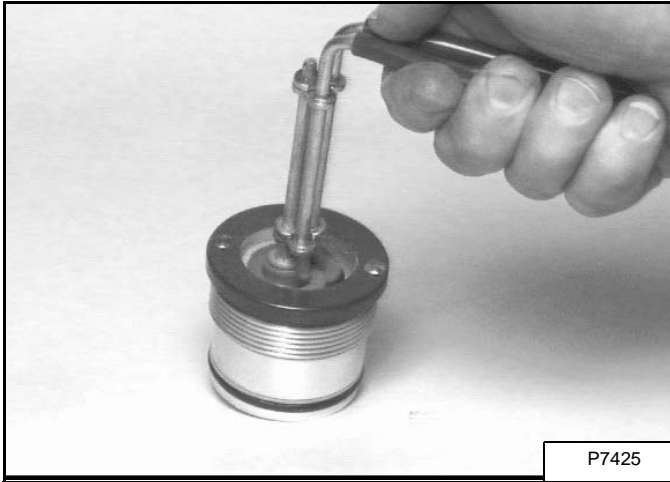

Install the rod seal in the head [Figure 20-21-21].

Figure 20-21-22

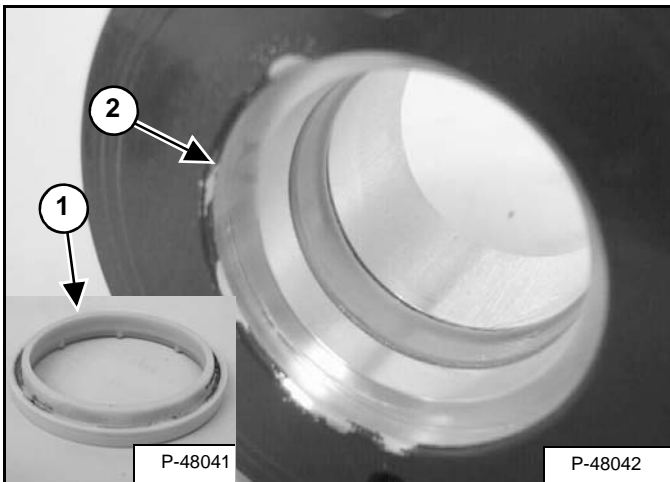

Install the wiper seal, with the wiper side of the seal (Item 1) toward the outside of the head (Item 2) [Figure 20-21-22].

Figure 20-21-23

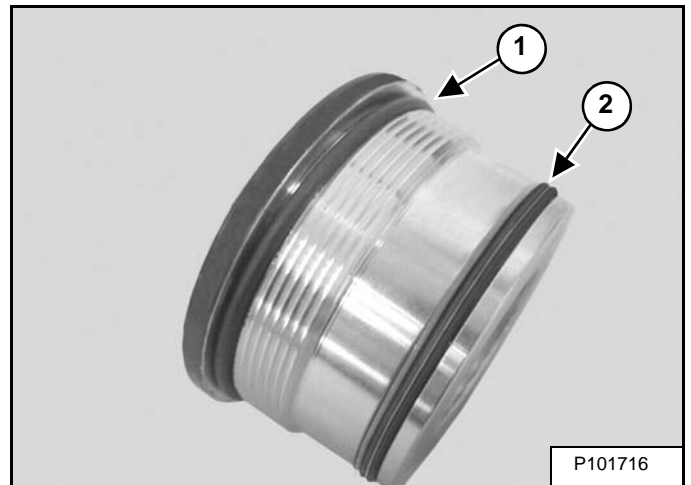

Install the O-ring (Item 1) and seal (Item 2) [Figure 20-21-16] on the cylinder head.

Figure 20-21-24

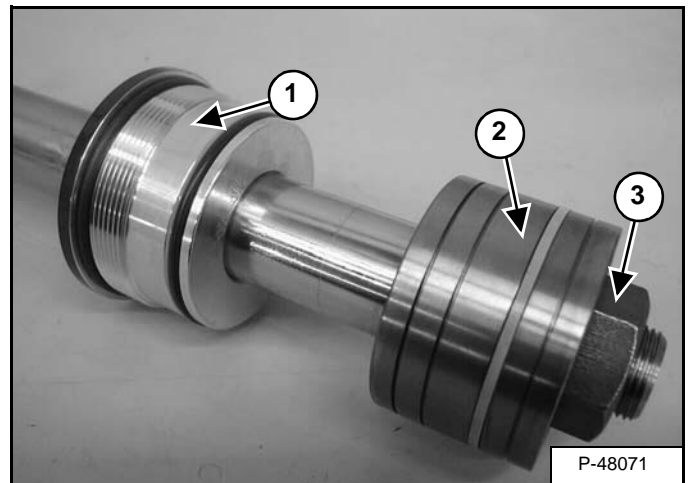

**NOTE:** Clean and dry the threads before installing the nut. Install the new nut from the kit.

Install the head (Item 1), piston (Item 2) and nut (Item 3) [Figure 20-21-24].

Tighten the nut (Item 3) [Figure 20-21-24] to 1152 N•m (850 ft-lb) torque.

Put the base end of the hydraulic cylinder in a vise.

## **MAIN RELIEF VALVE**

### **Description**

The main relief valve limits the hydraulic system pressure by opening at a certain pressure and allowing the hydraulic oil to flow back to the hydraulic reservoir. (See Hydraulic System on Page SPEC-10-3.)

The main relief valve is adjustable and is located on the hydraulic control valve near the bottom, facing the front of the loader.

## HYDRAULIC CONTROL VALVE (STANDARD) (CONT'D)

### Removal And Installation (Cont'd)

Figure 20-40-11

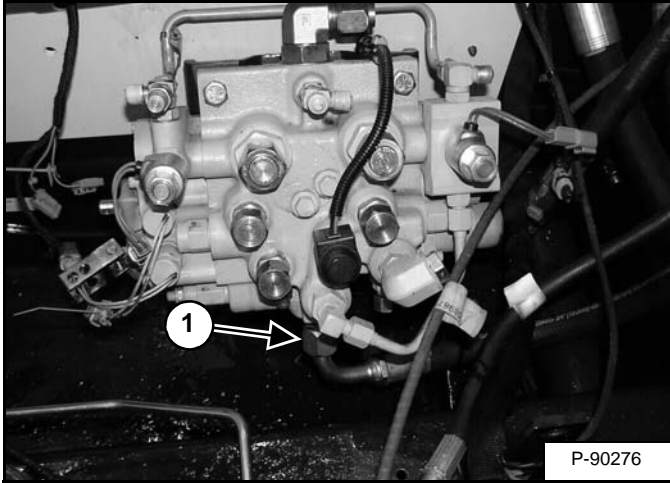

Disconnect the hose (Item 1) [Figure 20-40-11] that routes from the bottom of the control valve to the outlet fitting of the hydraulic pump.

Figure 20-40-12

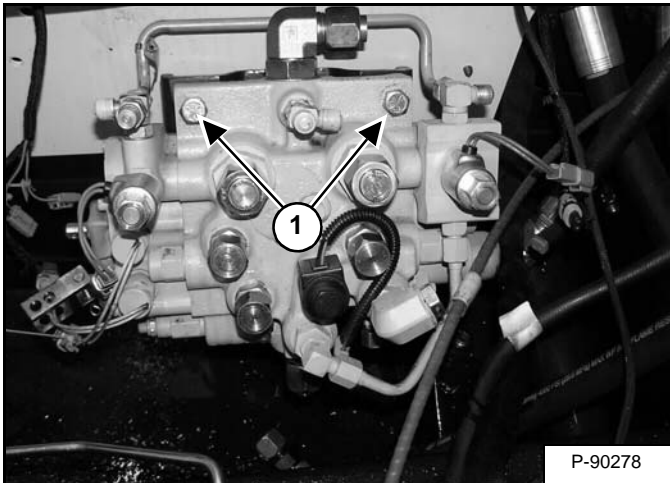

Support the control valve and remove the two bolts (Item 1) [Figure 20-40-12].

Remove the control valve from the loader.

## Mount Bracket Removal And Installation

Figure 20-40-13

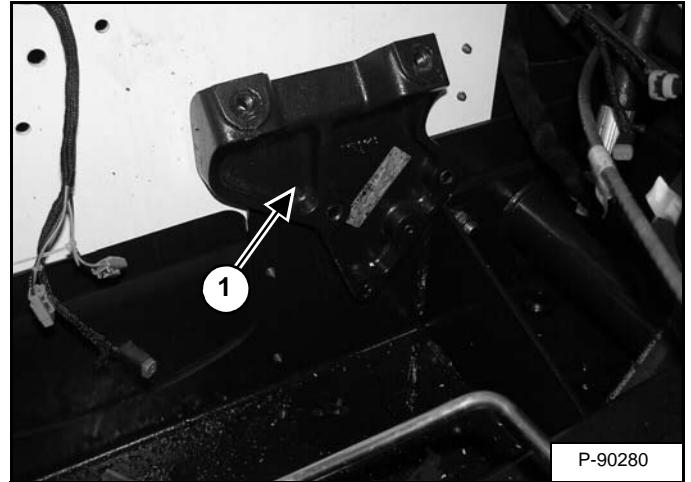

Support the mounting bracket (Item 1) [Figure 20-40-13].

Figure 20-40-14

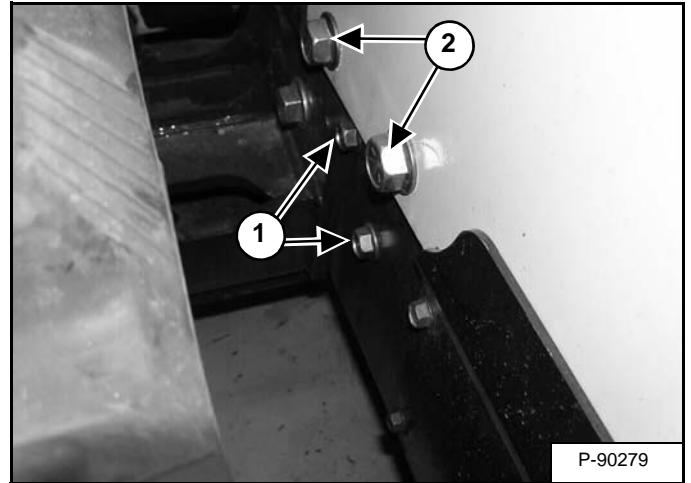

Remove the two control valve mount bolts (Item 1) [Figure 20-40-14].

Remove the two frame bolts (Item 2) [Figure 20-40-14]

**Installation:** Torque the two frame bolts (Item 2) [Figure 20-40-14] to 406 - 447 N•m (300 - 330 ft-lb).

Remove the control valve bracket from the loader.

## HYDRAULIC CONTROL VALVE (STANDARD) (CONT'D)

### Lift Spool And Detent Removal And Installation

The tool listed will be needed to do the following procedure:

MEL1278 - Detent Tool

MEL1285 - Detent Spring Tool

Remove the end cap / spool lock block from the control valve.

**Figure 20-40-43**

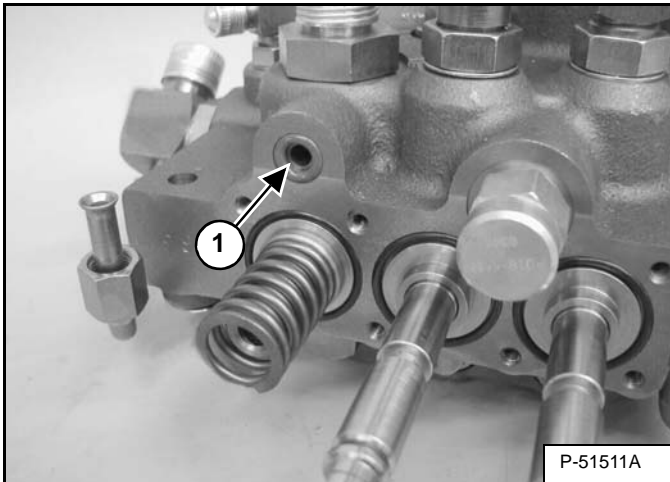

Remove the O-ring (Item 1) [Figure 20-40-43].

**Installation:** Replace the O-ring, and lubricate the o-ring lightly with grease or oil before installation of the end cap/spool lock block.

**Figure 20-40-44**

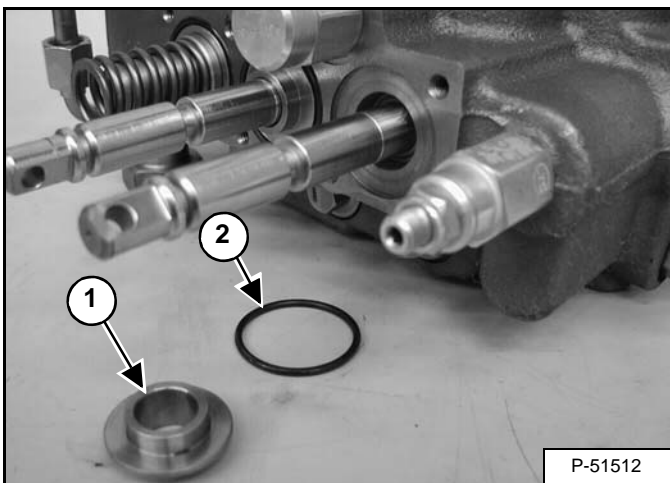

Remove the spacer (Item 1) and O-ring (Item 2) [Figure 20-40-44] from the lift spool.

**Figure 20-40-45**

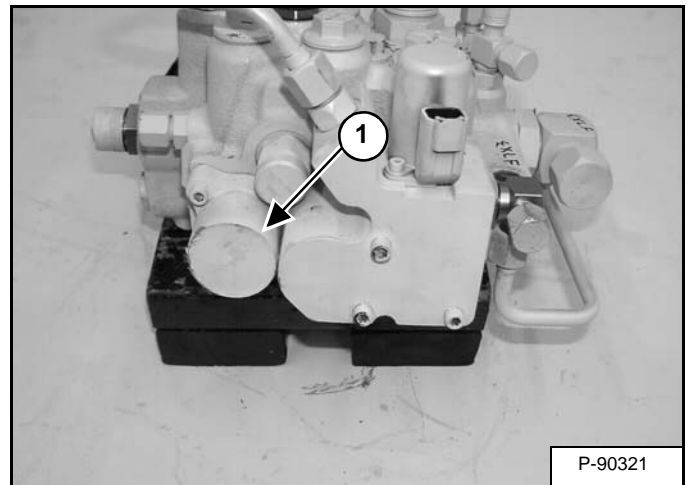

Remove the end cap (Item 1) [Figure 20-40-45].

**Figure 20-40-46**

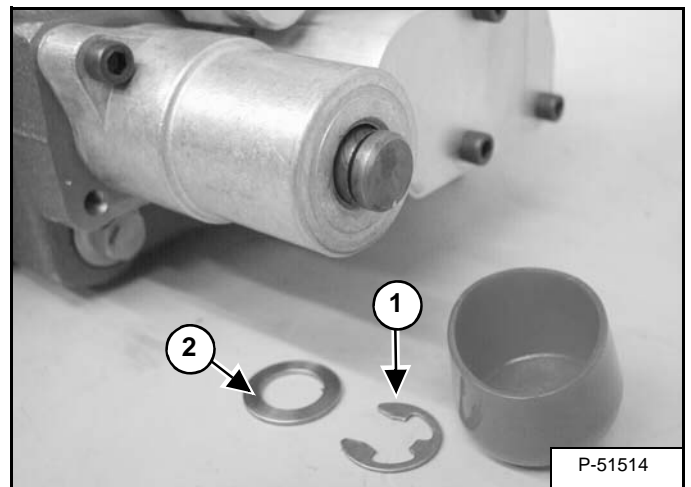

Use a screwdriver to remove the snap ring (Item 1) [Figure 20-40-46].

Remove the washer (Item 2) [Figure 20-40-46].

## HYDRAULIC CONTROL VALVE (STANDARD) (CONT'D)

### Tilt Spool Removal And Installation

Remove the lift and tilt end cap/spool lock block. (See End Cap Block Removal And Installation on Page 20-40-14.)

Figure 20-40-81

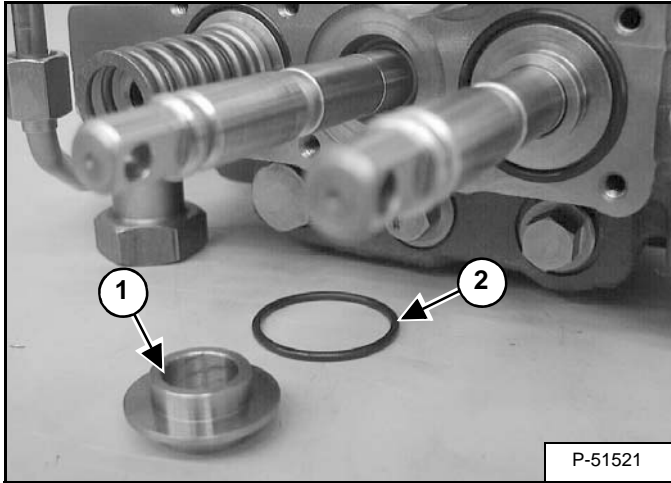

Remove the spacer (Item 1) and O-ring (Item 2) [Figure 20-40-81] from the tilt spool.

Figure 20-40-82

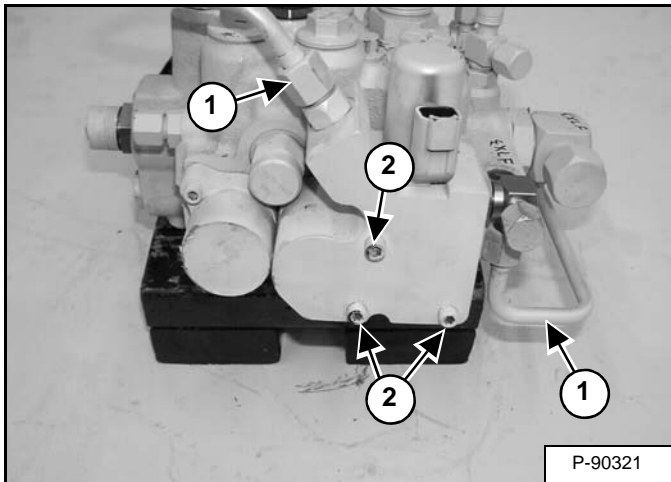

Disconnect the two tubelines (Item 1) [Figure 20-40-82] from the spool centering block.

Remove the three screws (Item 2) [Figure 20-40-82] from the spool centering block.

**Installation:** Tighten the bolt to 10,2 - 11,3 N•m (90 - 100 in-lb) torque.

Figure 20-40-83

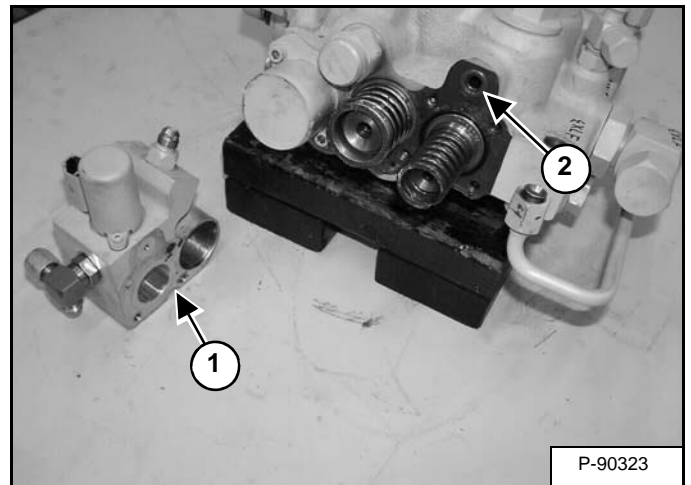

Remove the spool centering block (Item 1) [Figure 20-40-83] from the control valve.

**Installation:** Replace the O-ring (Item 2) [Figure 20-40-83] and lubricate the O-ring lightly with grease or oil before installation of the end cap / spool lock block.

Figure 20-40-84

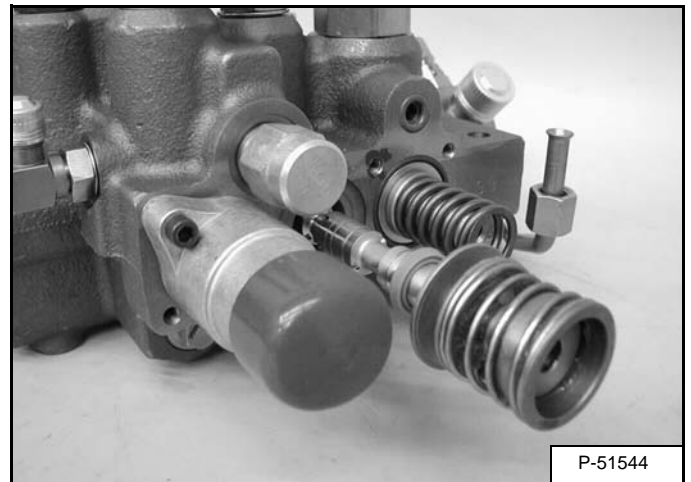

Remove the tilt spool, centering spring, back-up washer and spool seal [Figure 20-40-84].

**Assembly:** Always use a new spool seal.

## HYDRAULIC CONTROL VALVE (ACS) OR (SJC)

### Description

Figure 20-41-1

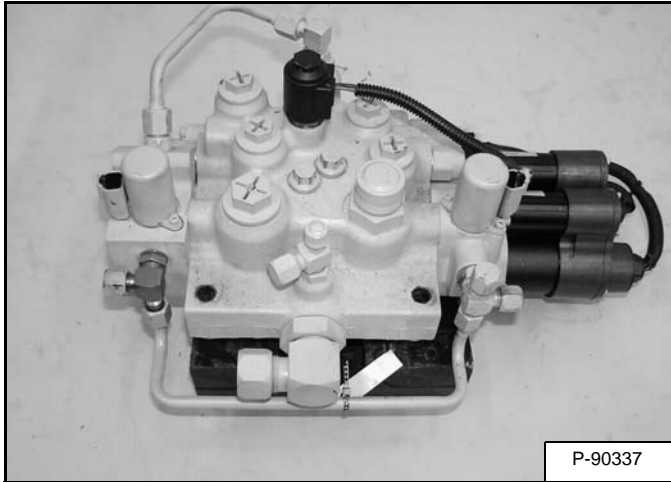

The hydraulic control valve is located inside the main frame on the right hand side, below the operator's cab.

The hydraulic control valve is the hydraulic component that uses spools to direct the flow of hydraulic fluid to the lift, tilt and auxiliary functions.

The lift and tilt functions in the hydraulic control valve are operated using electronic control handles / levers that send an electronic signal to the electronic actuators to move the lift and tilt spools in the control valve.

The auxiliary function is operated by pilot pressure. There is one solenoid located by each side of the spool. Only one solenoid at a time is activated by the switch on the right side control handles / levers. The activated solenoid sends pilot pressure oil to one side of the spool and forces the spool to shift.

The hydraulic control valve also contains a main relief valve which is adjustable.

## Removal And Installation



# DANGER



P-90328

### AVOID DEATH

- Disconnecting or loosening any hydraulic tubeline, hose, fitting, component or a part failure can cause lift arms to drop.
- Keep out of this area when lift arms are raised unless supported by an approved lift arm support. Replace if damaged.

D-1009-0409



# WARNING

Never work on a machine with the lift arms up unless the lift arms are secured by an approved lift arm support device. Failure to use an approved lift arm support device can allow the lift arms or attachment to fall and cause injury or death.

W-2059-0598

# IMPORTANT

When repairing hydrostatic and hydraulic systems, clean the work area before disassembly and keep all parts clean. Always use caps and plugs on hoses, tubelines and ports to keep dirt out. Dirt can quickly damage the system.

I-2003-0888

## HYDRAULIC CONTROL VALVE (ACS) OR (SJC) (CONT'D)

### Mount Bracket Removal And Installation

Figure 20-41-27

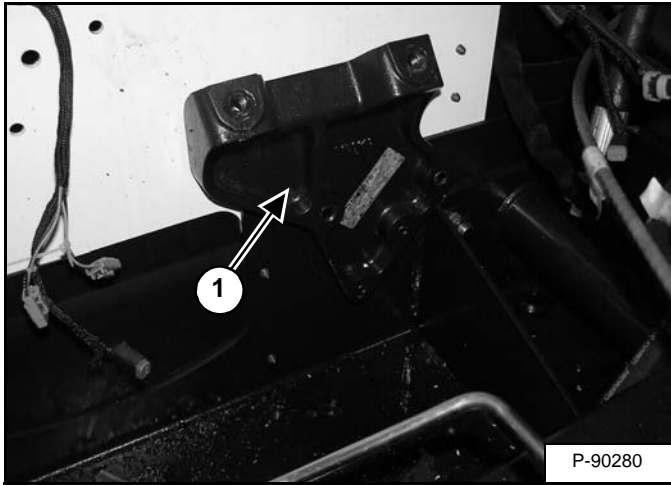

Support the mounting bracket (Item 1) [Figure 20-41-27].

Figure 20-41-28

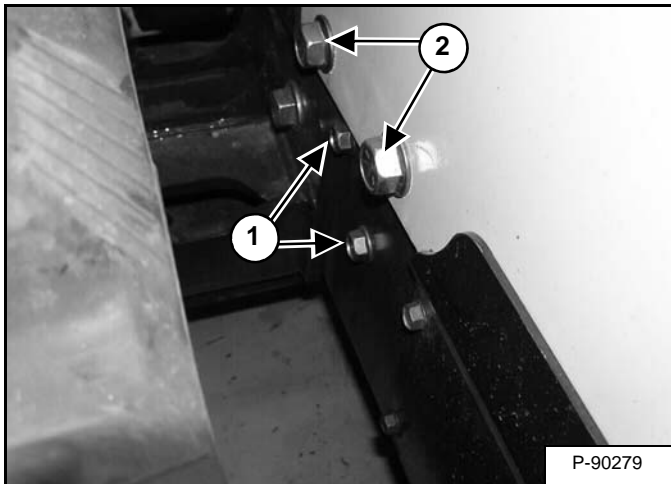

Remove the two control valve mount bolts (Item 1) [Figure 20-41-28].

Remove the two frame bolts (Item 2) [Figure 20-41-28]

**Installation:** Torque the two frame bolts (Item 2) [Figure 20-41-28] to 406 - 447 N•m (300 - 330 ft lb).

Remove the control valve bracket from the loader.

### Lift Load Check Valve Removal And Installation

Figure 20-41-29

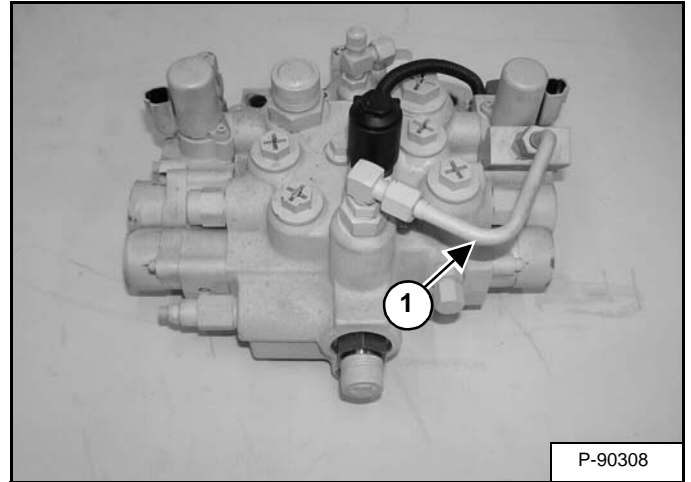

Remove the charge tubeline (Item 1) [Figure 20-41-29] from the BICS valve fitting on the top of the lift load check valve.

Figure 20-41-30

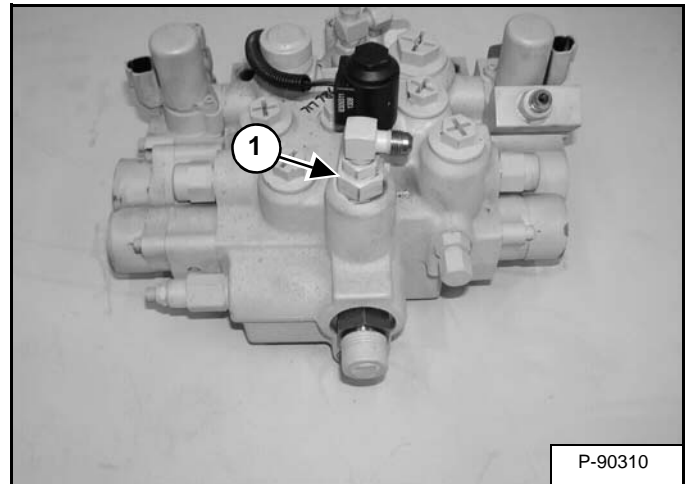

Remove the lift load check valve (Item 1) [Figure 20-41-30] and fitting from the top of the control valve.

**Installation:** Lubricate the O-ring and threads and tighten to 75 - 88 N•m (55 - 65 ft-lb) torque.

## HYDRAULIC CONTROL VALVE (ACS) OR (SJC) (CONT'D)

### Lift Spool Removal And Installation (Cont'd)

Figure 20-41-66

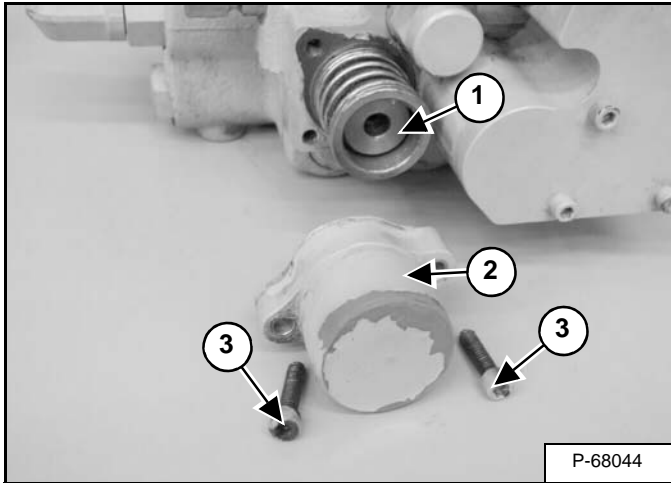

Install the lift spool assembly (Item 1) [Figure 20-41-66] in the spool bore.

Install the end cap (Item 2) [Figure 20-41-66].

Install the mounting screws (Item 3) [Figure 20-41-66].

**Installation:** Lubricate the screws and tighten to 10,2 - 11,3 N•m (90 - 100 in-lb) torque.

Figure 20-41-67

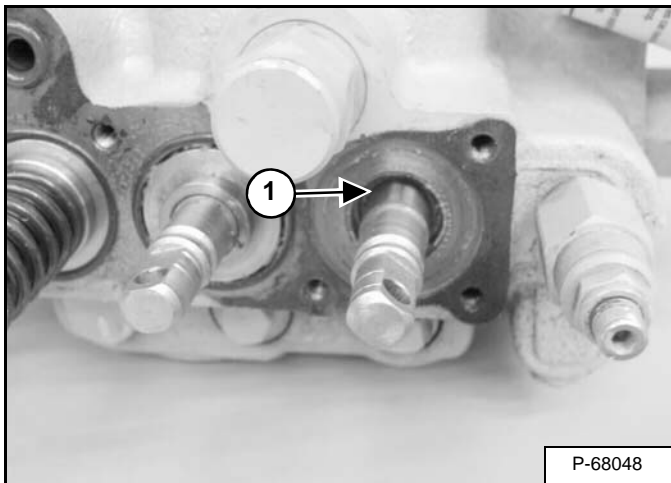

Install the spool seal (Item 1) [Figure 20-41-67] on the linkage end of the valve.

Figure 20-41-68

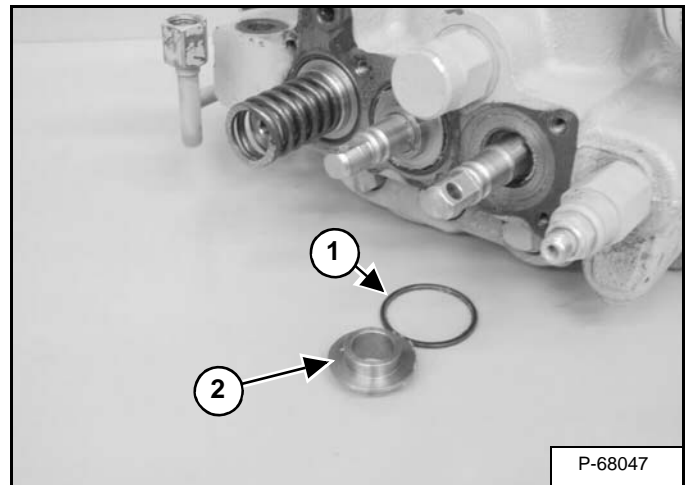

Install the O-ring (Item 1) and bushing (Item 2) [Figure 20-41-68] on the lift spool.

Figure 20-41-69

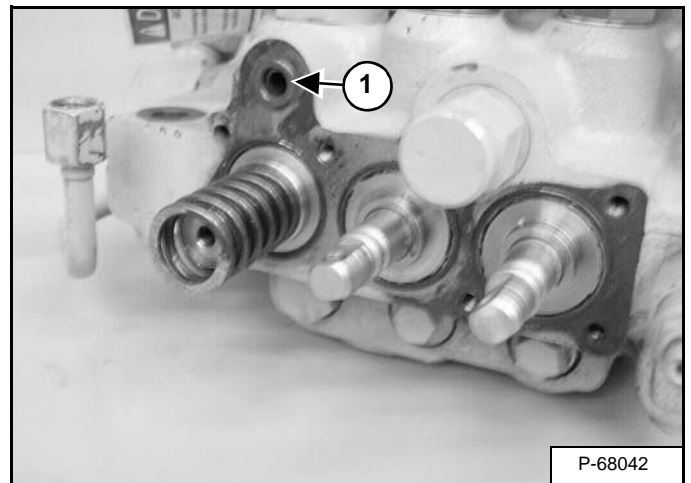

Install the O-ring (Item 1) [Figure 20-41-69] on the control valve.

**Installation:** Replace the O-ring, lubricate lightly with oil or grease before installation of the end cap block.

## LIFT ARM BYPASS CONTROL VALVE

### Description

The lift arm bypass control valve is located on the right side of the machine.

The lift arm bypass control valve is manually operated by pulling on the valve (Item 1) **[Figure 20-50-1]** and turning the knob 90° clockwise. The valve releases the hydraulic fluid from the base end of the lift cylinder(s) which allows the lift arm to slowly come down to the transport position.

### Testing

Figure 20-50-1

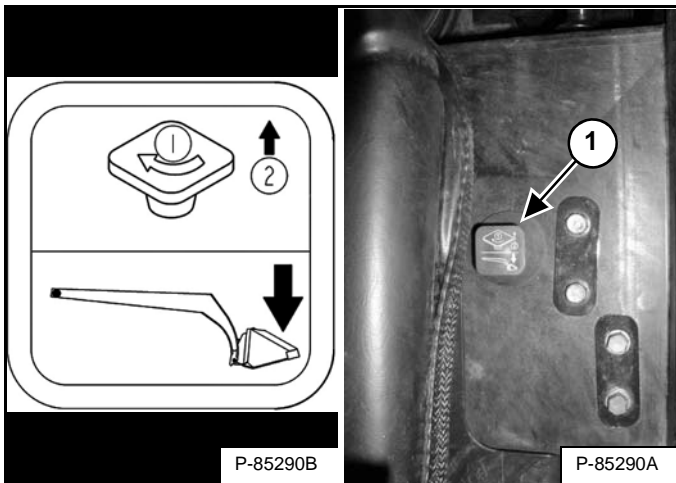

Raise the lift arms 2 m (6 ft) off the ground. Stop the engine. Turn the Lift Arm Bypass Control Knob (Item 1) **[Figure 20-50-1]** 90° clockwise. Then pull up and hold the Lift Arm Bypass Control Knob until the lift arms slowly lower.

The knob should return to its normal position.

## HYDRAULIC PUMP (CONT'D)

### Removal And Installation (Cont'd)

Figure 20-60-8

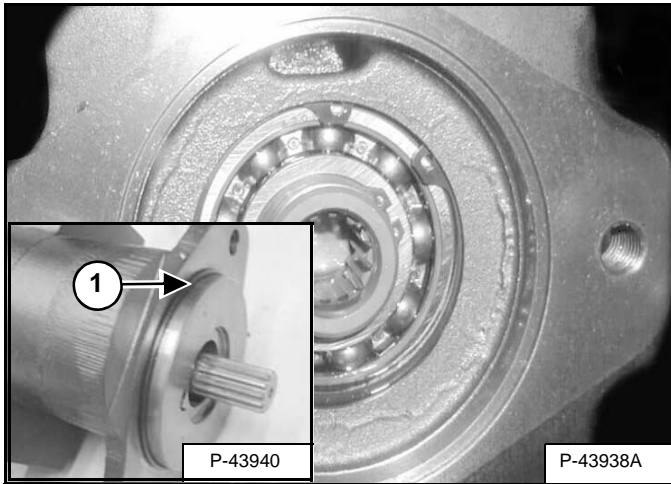

Replace the O-ring (Item 1) [Figure 20-60-8] on the hydraulic pump.

Reverse the removal procedure to install the hydraulic pump.

## Hydraulic Pump Startup

**NOTE:** This procedure is necessary to prevent a dry startup of the hydraulic pump.

Fill the system with hydraulic fluid. (See Removing And Replacing Hydraulic Fluid on Page 10-120-2.)

Figure 20-60-9

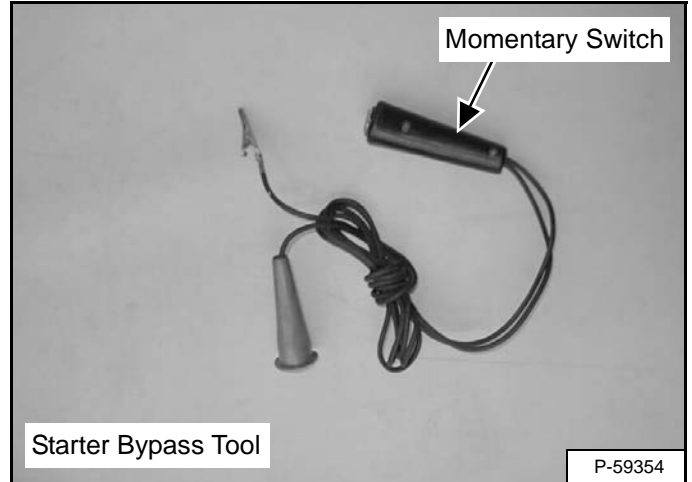

To crank the engine without starting, the machine key switch can be bypassed. Obtain a starter bypass tool from a local source which can be used as a universal connection to remotely crank the engine without starting.

The starter bypass tool consists of two wires, each with a clamp. The momentary switch, when depressed, will allow current to pass through the circuit.

Connect the starter bypass tool to the starter solenoid battery terminal and S terminal. Crank the engine for 15 seconds, then stop for at least 30 seconds. Again, crank the engine for 15 seconds. Remove the starter bypass tool.

Start the loader from the operators cab and run the engine at low idle for 1 - 2 minutes without operating the hydraulics.

After operating the engine at low idle, remove the lift arm support device and fully raise and lower the loader lift arms several times or until air is purged from the system. **Avoid running over the relief valve setting at the end of cylinder stroke.**

With the loader parked on a level surface and lift arms down, check and fill the hydraulic reservoir as required. Check for hydraulic leaks.

## HYDRAULIC PUMP (HIGH FLOW) (CONT'D)

### High Flow Relief Valve Adjustment

If the pump is unable to reach 3500 PSI stop the engine. The relief screw (Item 1) [Figure 20-61-11] will need to be turned clockwise 90° and retested with the procedure above. (90° equals approximately 1,4 MPa (13,8 bar) (200 PSI).)

**NOTE:** If the relief screw has been turned in 1/4 turn and the pressure remains the same, go to the high flow relief valve removal and installation section. (See High Flow Relief Valve Removal And Installation on Page 20-61-8.) If relief valve has been checked and is OK, go to the high flow pump disassembly and assembly section. (See Disassembly And Assembly on Page 20-61-13.)

Remove right rear wheel. (See Wheel Nuts on Page 10-160-1.)

Figure 20-61-9

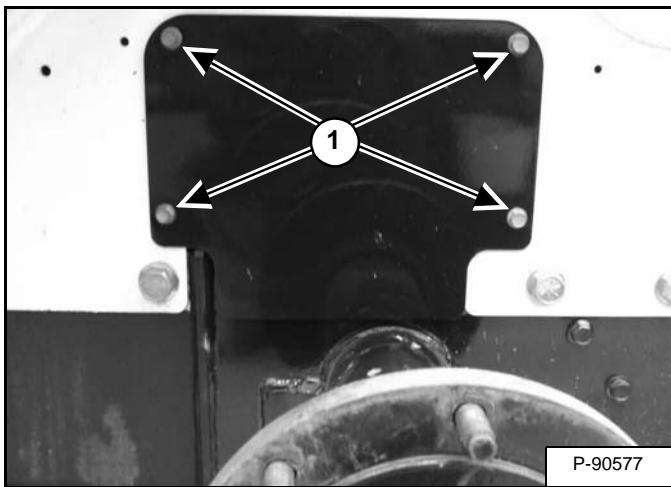

Remove the mounting bolts (Item 1) [Figure 20-61-9] from the access cover and remove the cover from the loader.

Figure 20-61-10

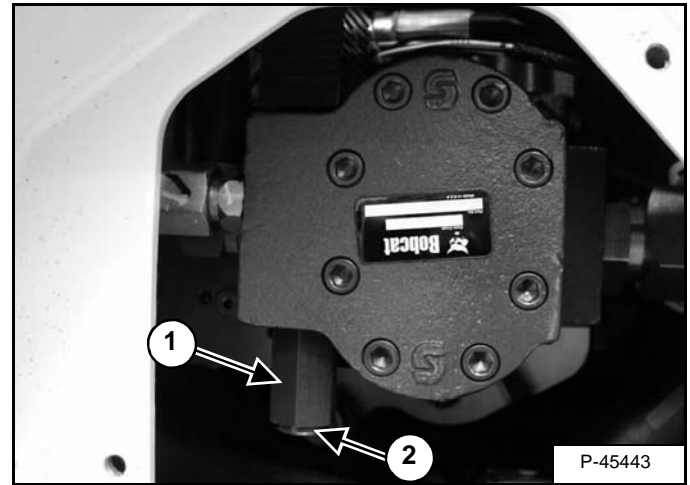

Locate the high flow relief valve (Item 1) [Figure 20-61-10] along the right side of the engine.

Remove the plug (Item 2) [Figure 20-61-10] located on the bottom of the high flow relief valve.

Figure 20-61-11

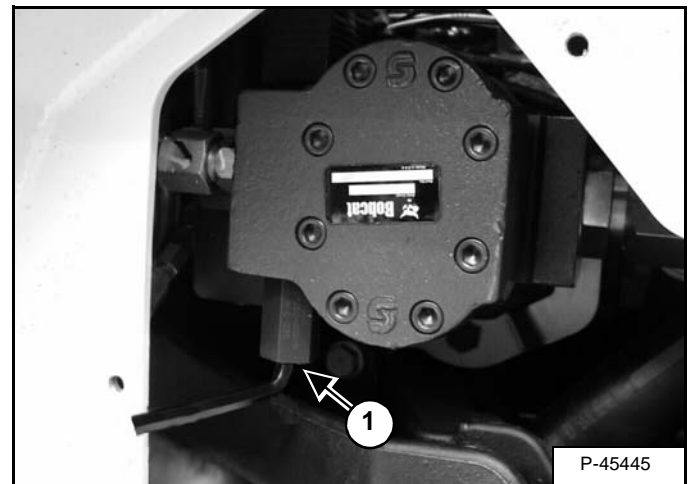

**NOTE:** [Figure 20-61-11] shows adjusting the relief screw.

If the pump reaches 25,5 MPa (255,1 bar) (3700 psi) and there is flow stop the engine. The relief screw must be turned 90° counterclockwise and retested with the procedure above.

## HYDRAULIC FLUID RESERVOIR

### Description

The hydraulic fluid reservoir is a storage container for the loader's hydraulic / hydrostatic fluid. The reservoir contains a vented fill cap with a fluid screen to prevent contaminants from entering the reservoir while adding fluid.

The hydraulic fluid reservoir is located behind the operator's cab under the rear grille on the right side of the loader.

### Removal And Installation

Raise the lift arms and install an approved lift arm support device. (See Installing on Page 10-20-1.)

Raise the operator cab. (See Raising on Page 10-30-2.)

Drain the fluid from the reservoir. (See Removing And Replacing Hydraulic Fluid on Page 10-120-2.)

Remove the Hydraulic / Hydrostatic Filter Housing (See Housing Removal And Installation on Page 20-70-1.)

Remove the rear grille (See Removal And Installation on Page 50-60-1.)

**Figure 20-80-1**

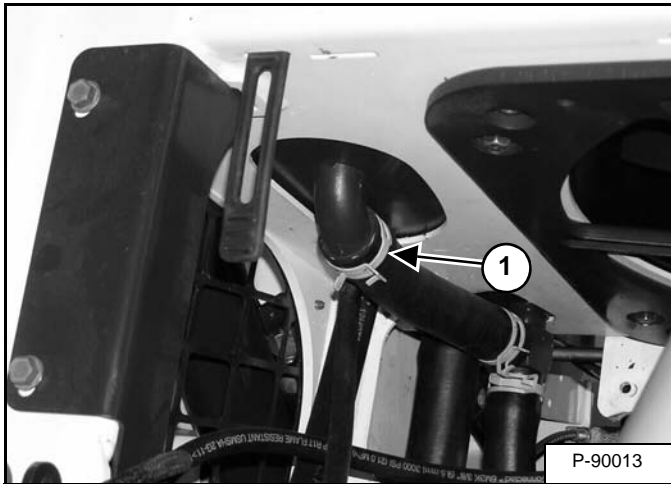

Remove the clamp and the hose (Item 1) [Figure 20-80-1].

**Figure 20-80-2**

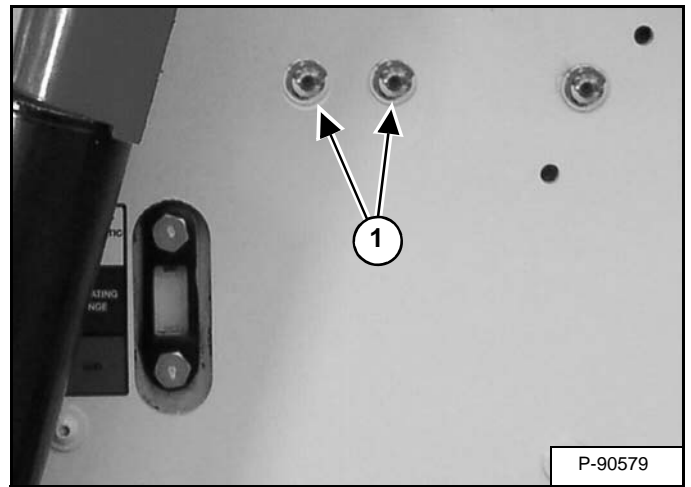

Remove the two bolts (Item 1) [Figure 20-80-2].

Remove the hydraulic fluid reservoir from the loader.

**Installation:** Tighten the mount bolts and nuts to 21,7 - 24,4 N•m (16 - 18 ft-lb) torque.

## REAR AUXILIARY DIVERTER VALVE (CONT'D)

### Removal And Installation (Cont'd)

Figure 20-110-5

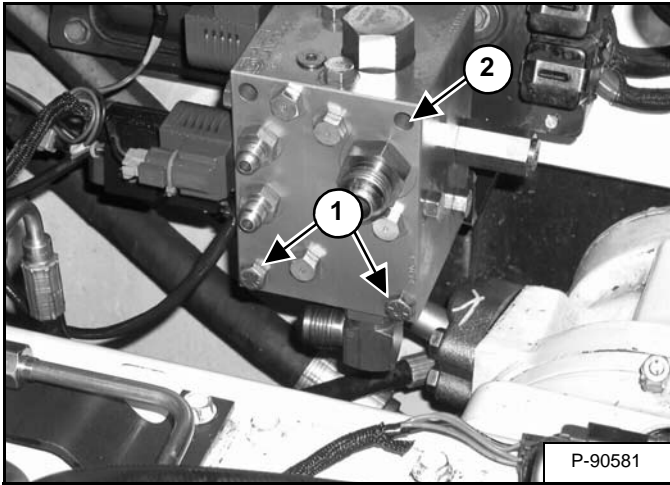

Remove the two bolts (Item 1) and remove the valve (Item 2) [Figure 20-110-5]

## Disassembly And Assembly

Figure 20-110-6

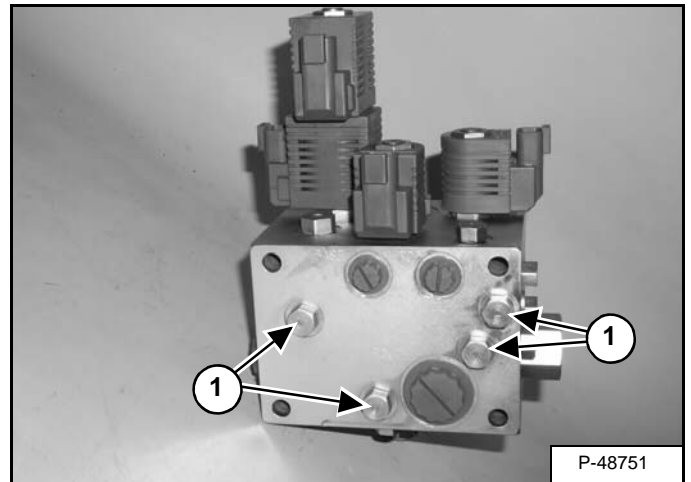
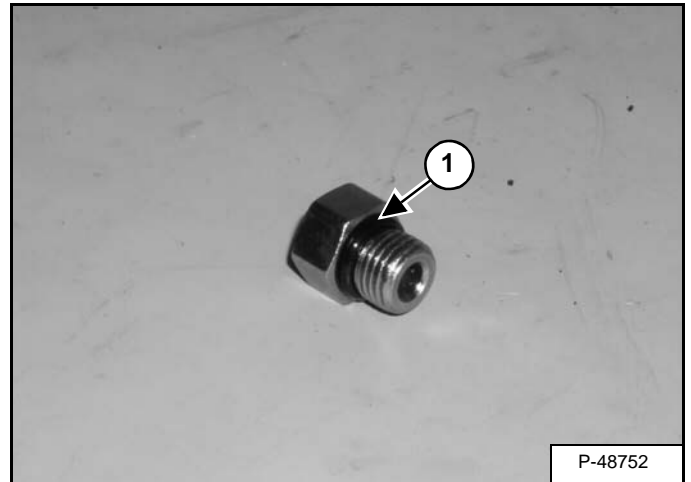

Figure 20-110-7



Clean the diverter valve to remove dirt before disassembly. Valve ports are labeled for correct assembly.

Several plugs (Item 1) [Figure 20-110-6] and [Figure 20-110-7] are located all over the diverter valve and can be removed for clean out purposes.

**Assembly:** Put oil on O-rings and back-up washers. Tighten to 13,6 N•m (10 ft-lb) torque.

## BOB-TACH (POWER) BLOCK (CONT'D)

### Disassembly And Assembly (Cont'd)

Figure 20-120-10

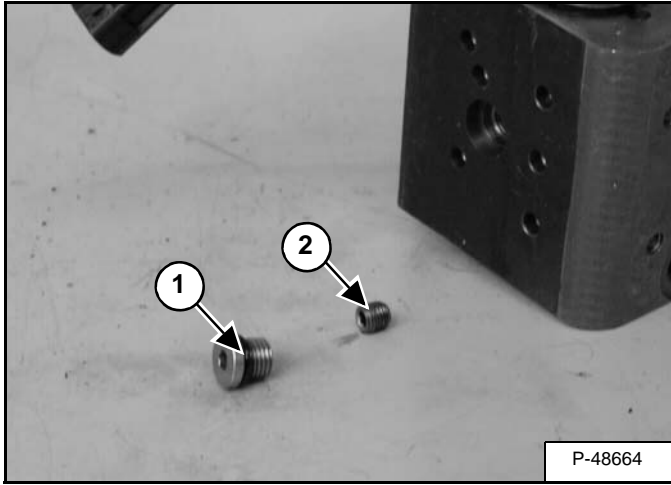

Remove the orifice screw (Item 2) located behind the plug (Item 1) [Figure 20-120-10].

**Installation:** Tighten the orifice screw (Item 2) [Figure 20-120-10] to 8,1 - 10,8 N•m (6 - 8 ft-lb) torque.

Figure 20-120-11

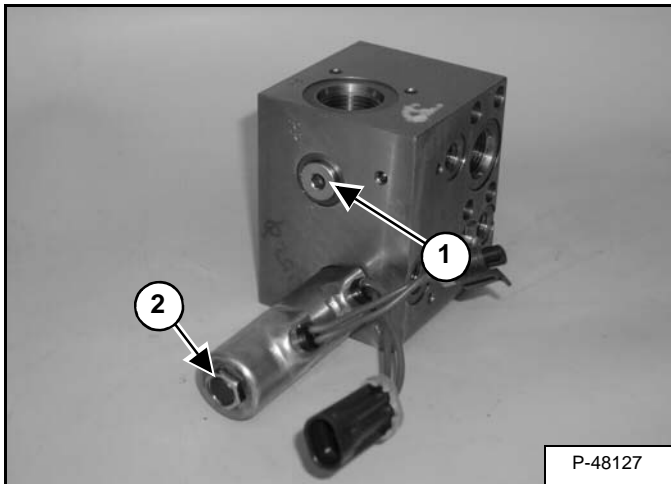

**NOTE:** This plug is a zero leak plug and should not be removed. If removed damage may occur and the plug and O-ring must be replaced.

Do not remove the plug (Item 1) [Figure 20-120-11].

Remove the solenoid nut (Item 2) [Figure 20-120-11].

**Installation:** Tighten the solenoid valve stem nut to 1,7 - 5,1 N•m (15 - 45 in-lb) torque.

Figure 20-120-12

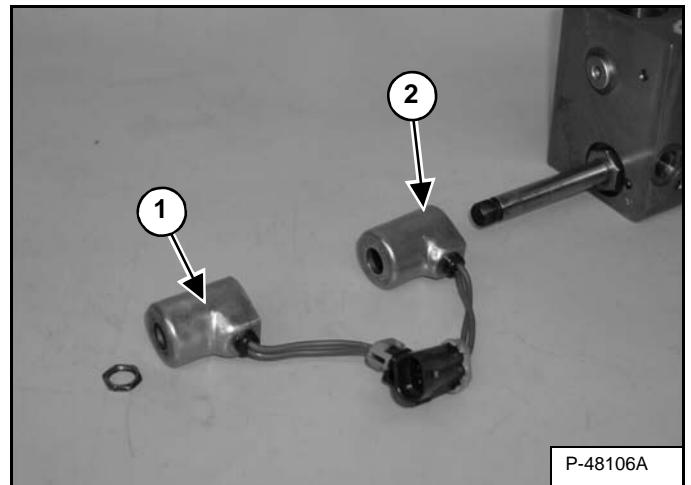

Remove the first solenoid coil (Item 1) and the second solenoid coil (Item 2) [Figure 20-120-12].

**NOTE:** Remember the solenoid coil orientation for ease of installation.

Figure 20-120-13

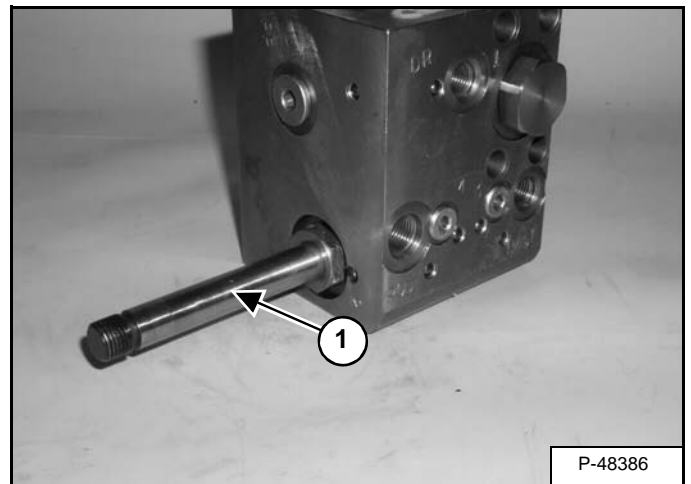

Remove the solenoid stem (Item 1) [Figure 20-120-13].

**Installation:** Tighten the solenoid stem to 27,1 - 34 N•m (20 - 25 ft-lb) torque.

## HYDROSTATIC DRIVE MOTOR (CONT'D)

### Removal And Installation (Cont'd)

Figure 30-20-3

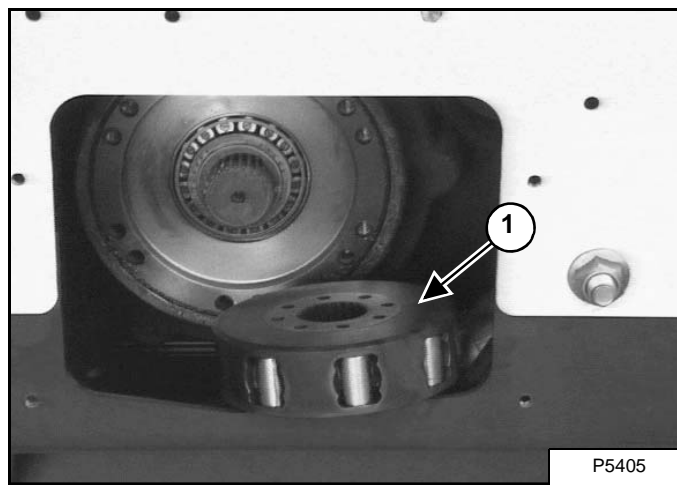

Remove the piston / roller section (Item 1) **[Figure 30-20-3]** from the loader, if it was not removed with the motor/cam ring.

To remove the motor carrier. (See Removal And Installation on Page 30-30-2.)

# HYDROSTATIC DRIVE MOTOR (TWO-SPEED) (CONT'D)

## Disassembly

Figure 30-21-7

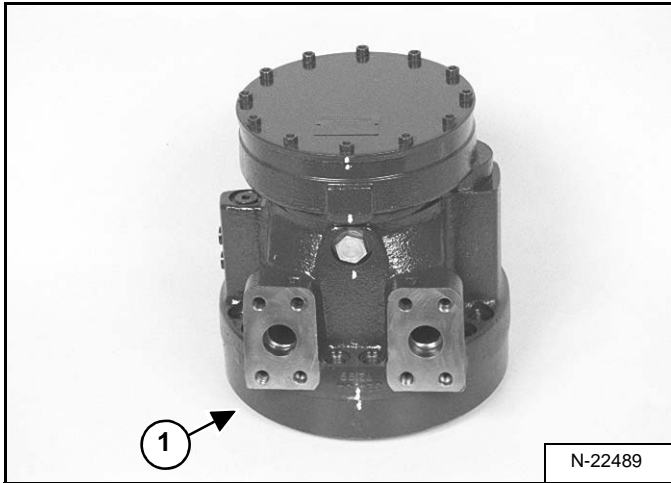

**NOTE:** Install a mark on the motor, brake, and motor carrier housings for correct assembly [Figure 30-21-7].

**NOTE:** Always protect any sealing surfaces. Any scratches or marks will cause premature failure.

Place the cam sealing surface (Item 1) [Figure 30-21-7] on a protective material.

Drain the oil from the motor casing.

Figure 30-21-8

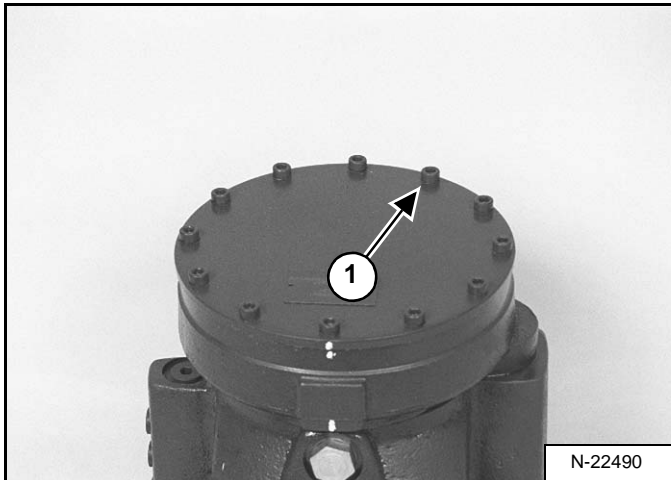

Remove the twelve mounting bolts (Item 1) [Figure 30-21-8] from the brake cover plate.

**NOTE:** Remove and / or tightened the bolts one turn at a time to maintain equal preload on the end cap and the brake spring.

Figure 30-21-9

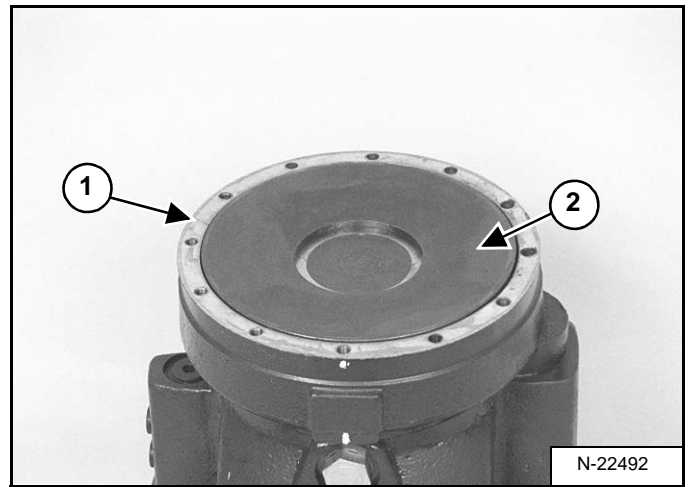

Remove the cover plate from the brake housing.

Remove the cover plate gasket (Item 1) [Figure 30-21-9].

Remove the brake spring (Item 2) [Figure 30-21-9] from the brake housing.

**NOTE:** Mark the top side of the brake spring for proper installation.

Figure 30-21-10

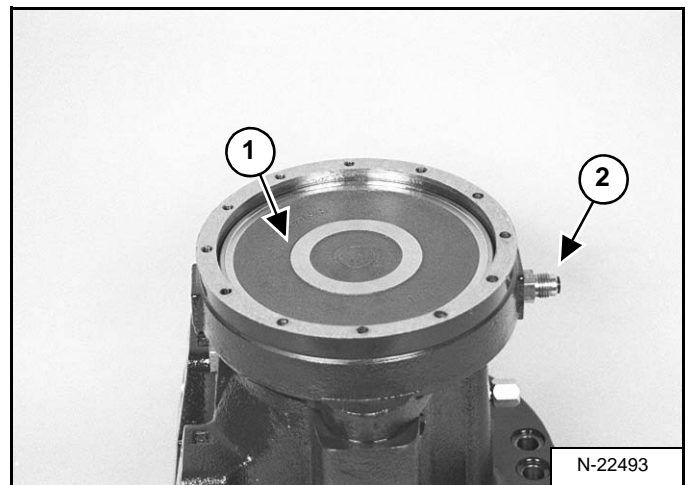

Remove the piston from the brake housing (Item 1) [Figure 30-21-10].

**NOTE:** The use of air pressure through the brake line connection (Item 2) [Figure 30-21-10] will aid in piston removal.

Check the brake piston for damage and replace the seal.

## HYDROSTATIC DRIVE MOTOR (TWO-SPEED) (CONT'D)

### Assembly (Cont'd)

Figure 30-21-47

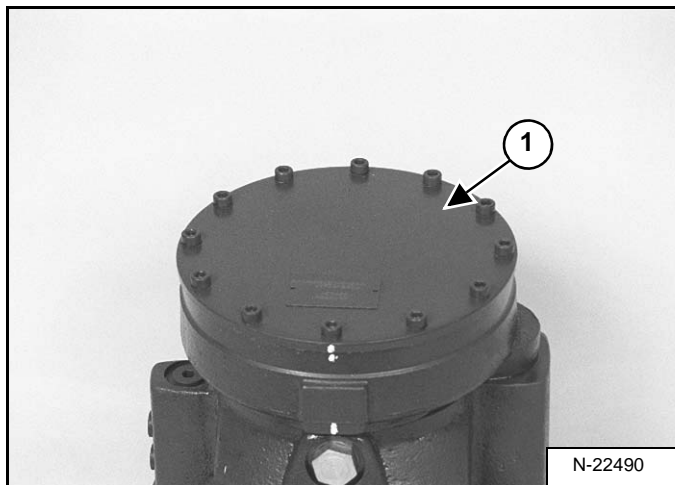

Install the brake end cover (Item 1) [Figure 30-21-47].

Install the twelve end cover mount bolts and tighten evenly to 14 - 16 N•m (10 - 12 ft-lb) torque.

# HYDROSTATIC MOTOR CARRIER (SJC) (CONT'D)

## Parts Identification

Ref.	Description
------	-------------

- |    |              |
|----|--------------|
| 1. | Snap Ring    |
| 2. | Bearing      |
| 3. | Race         |
| 4. | Seal         |
| 5. | Housing      |
| 6. | Speed Washer |
| 7. | Shaft        |
| 8. | Cover        |

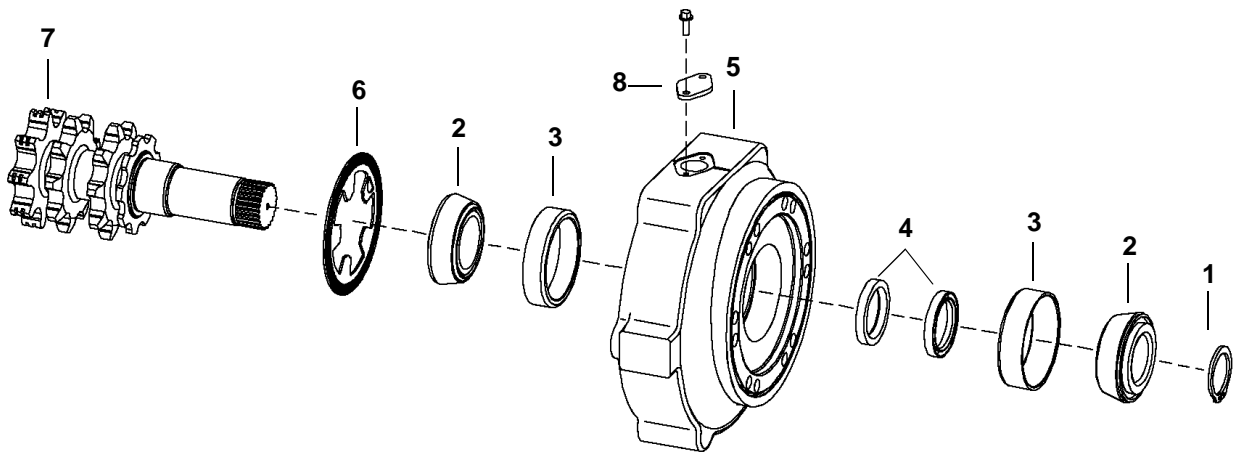

PE3328SA

## CHARGE PRESSURE (CONT'D)

### Adjusting (Cont'd)

SJC Machines

# IMPORTANT

When repairing hydrostatic and hydraulic systems, clean the work area before disassembly and keep all parts clean. Always use caps and plugs on hoses, tubelines and ports to keep dirt out. Dirt can quickly damage the system.

I-2003-0888

Figure 30-40-9

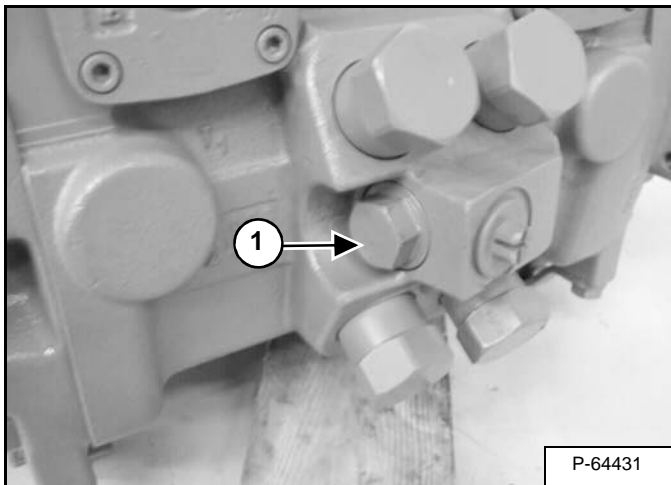

If the charge pressure is not correct remove the charge relief valve (Item 1) [Figure 30-40-9].

**NOTE:** The pump has been removed for photo clarity. The charge pressure relief valve is located on the engine side of the hydrostatic pump when installed in the loader.

**Assembly:** Always use a new O-ring. Tighten the plug to 41 - 68 N•m (30 - 50 ft-lb) torque.

Figure 30-40-10

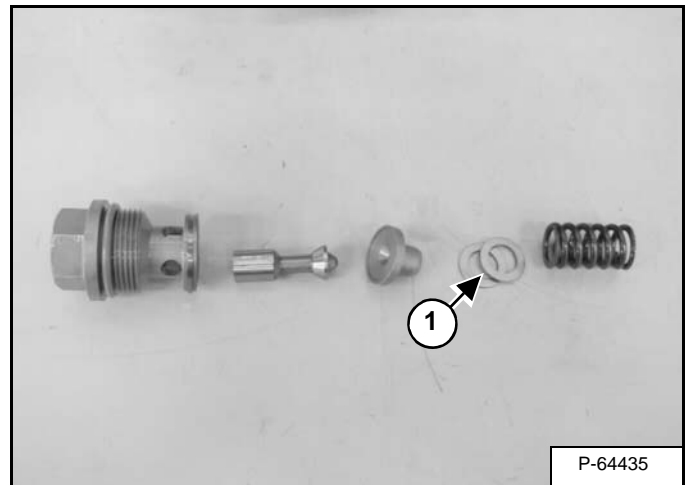

Check the poppet and spring for wear or damage.

Inspect the seat inside the hydrostatic pump case for wear or damage.

There are several different thickness of shims (Item 1) [Figure 30-40-10] used to adjust the charge pressure.

**NOTE:** 1,0 mm shim (Item 1) [Figure 30-40-10] = 300,0 kPa (3 bar) (43.5 PSI) in pressure change. Adding shims increases charge pressure. Removing shims decreases charge pressure.

The charge pressure should be set at 2,5 - 2,8 MPa (24,8 - 28,2 bar) (360 - 410 psi).

## HYDROSTATIC PUMP (CONT'D)

### Disassembly (Cont'd)

Figure 30-50-15

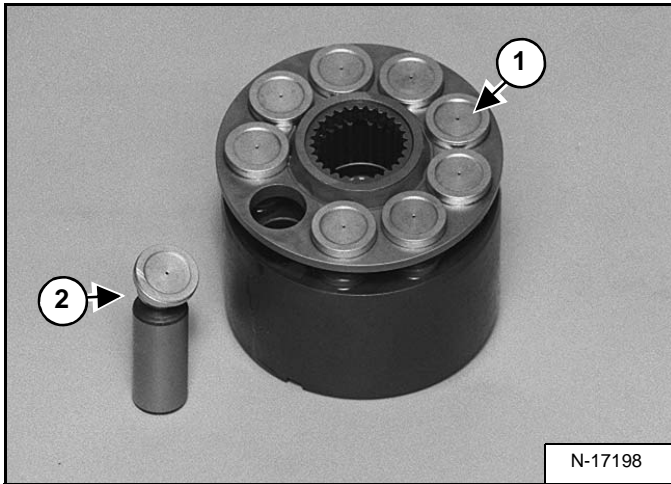

Remove the slipper guide and pistons (Item 1) [Figure 30-50-15] from the cylinder block.

Check all the pistons (Item 2) [Figure 30-50-15] for wear and replace the rotating group as needed.

Figure 30-50-16

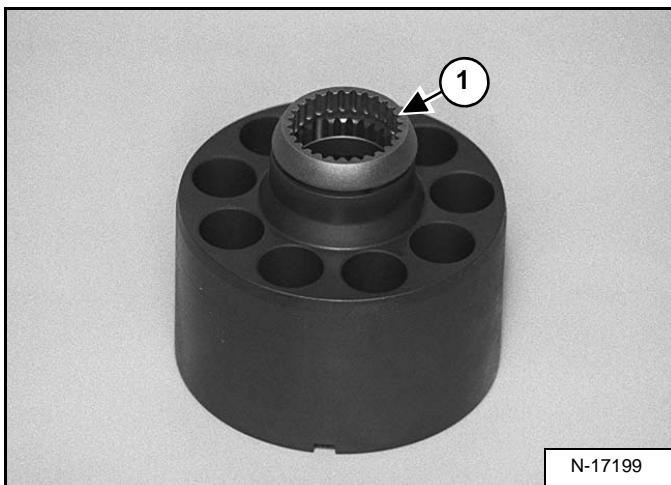

Remove the ball guide retainer (Item 1) [Figure 30-50-16] from the cylinder block.

Figure 30-50-17

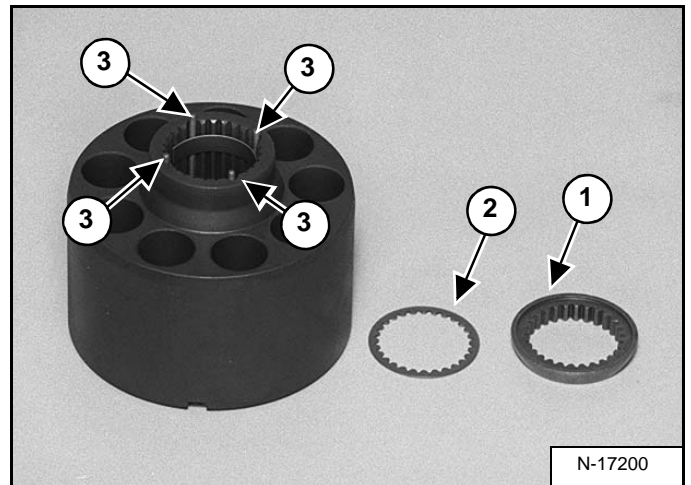

Check the ball guide retainer (Item 1) and washer (Item 2) [Figure 30-50-17] for wear and replace as needed.

Remove the four pins (Item 3) [Figure 30-50-17] from the cylinder block.

Check the cylinder block for wear and replace as needed.

Check pins (Item 3) [Figure 30-50-17] to see if they are all the same length.

Figure 30-50-18

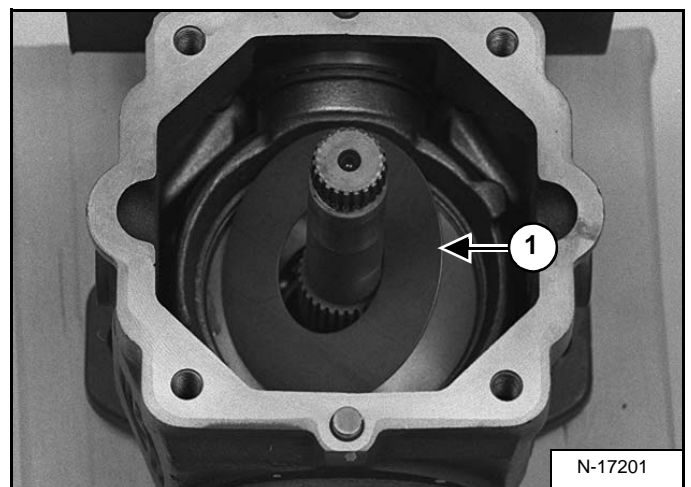

Remove the thrust plate (Item 1) [Figure 30-50-18] from the pump housing.

## HYDROSTATIC PUMP (CONT'D)

### Assembly (Cont'd)

Figure 30-50-54

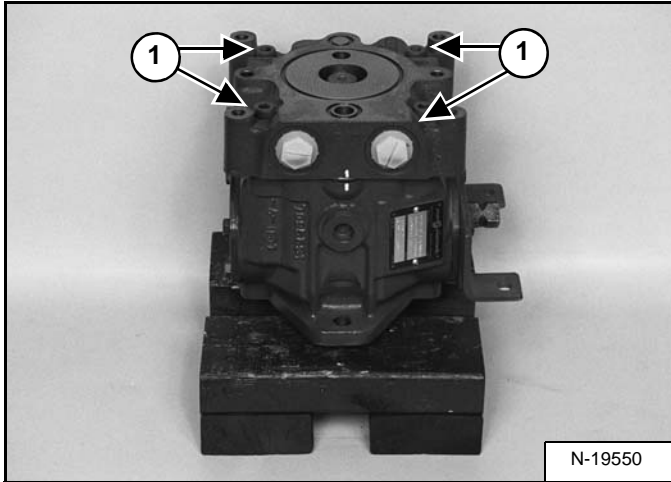

Install the valve plate and end cap on the pump housing. Tighten the bolts (Item 1) [Figure 30-50-54] to 47 - 61 N•m (35 - 45 ft-lb) torque.

Figure 30-50-55

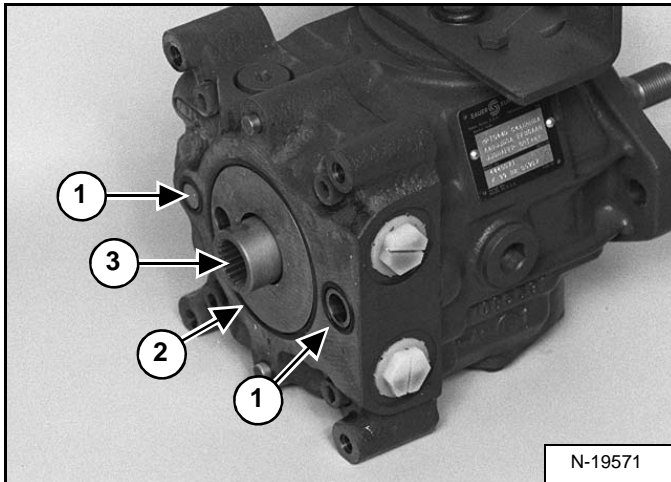

Install the two small O-rings (Item 1) [Figure 30-50-55].

Install the large new O-ring (Item 2) [Figure 30-50-55].

Install the pump coupler (Item 3) [Figure 30-50-55].

Figure 30-50-56

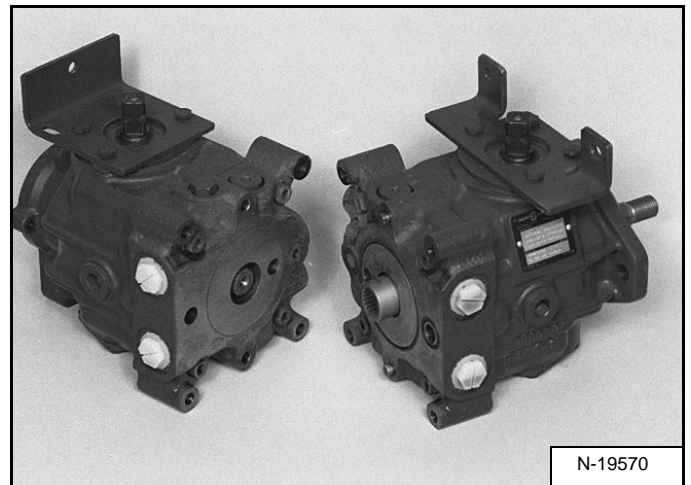

Install the two pumps together [Figure 30-50-56].

Figure 30-50-57

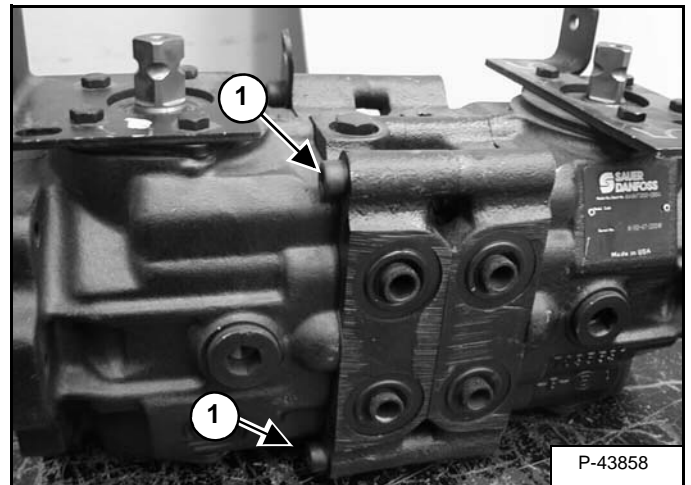

Tighten the four bolts (Item 1) [Figure 30-50-57] to 47 - 61 N•m (35 - 45 ft-lb) torque.

## HYDROSTATIC PUMP (SJC) (CONT'D)

### Charge Relief Valve

Figure 30-51-17

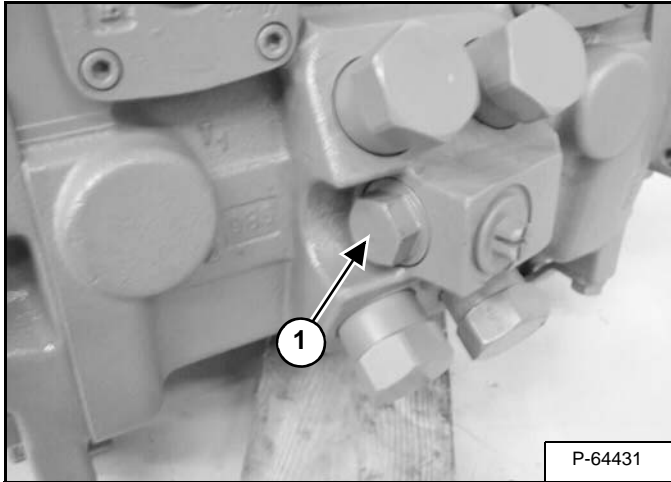

The charge relief valve (Item 1) [Figure 30-51-17] is located on the back of the hydrostatic pump.

Remove the charge relief valve.

**Assembly:** Tighten charge relief valve to 70 N•m (52 ft-lb) torque.

Figure 30-51-18

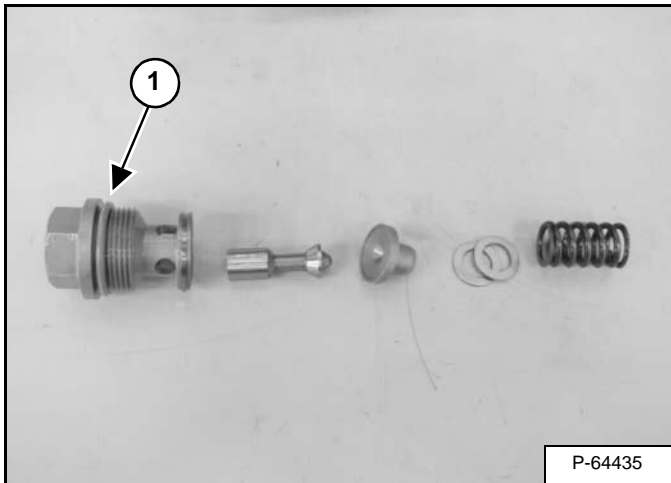

Check and replace the O-ring (Item 1) [Figure 30-51-18].

Figure 30-51-19

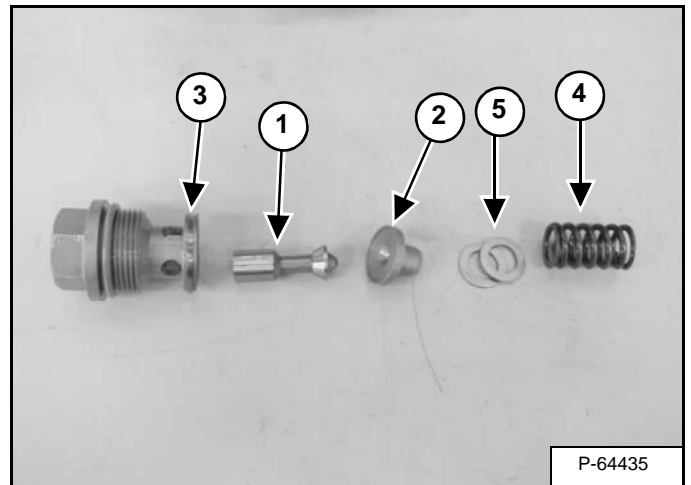

Inspect the poppet (Item 1) and the mating seat (Item 2) [Figure 30-51-19] for damage or foreign material. Ensure the poppet moves freely in its bore.

Inspect the sealing ring (Item 3) [Figure 30-51-19] and the mating seat in the pump housing for damage or foreign material.

Inspect the spring (Item 4) and the charge relief valve shims (Item 5) [Figure 30-51-19].

**NOTE:** 1,0 mm shim (Item 5) [Figure 30-51-19] = 296,5 kPa (3 bar) (43.5 psi) in pressure change. Adding shims increases charge pressure. Removing shims decreases charge pressure.

## HYDROSTATIC PUMP (SJC) (CONT'D)

### Disassembly And Assembly (Cont'd)

Figure 30-51-53

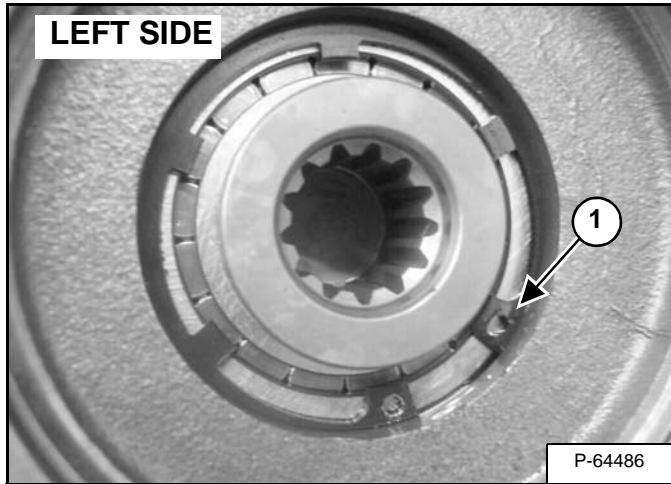
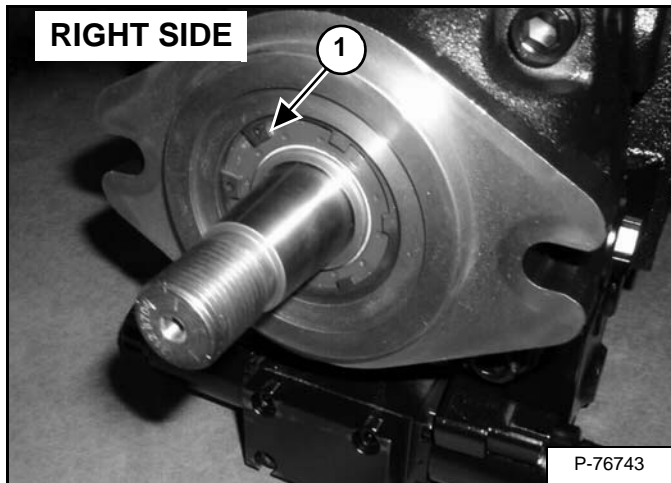
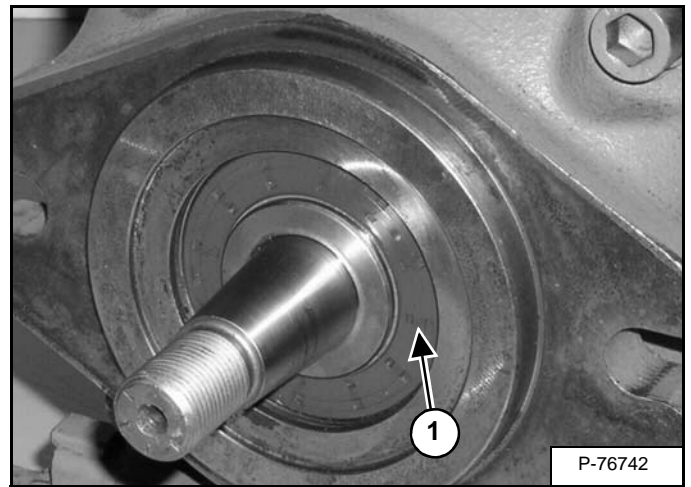

Figure 30-51-54



Remove the snap ring (Item 1) [Figure 30-51-53] and [Figure 30-51-54] from the end housing.

Figure 30-51-55



The pump seal (Item 1) [Figure 30-51-55] is removed by inserting a screw into the seal and prying out.

Figure 30-51-56

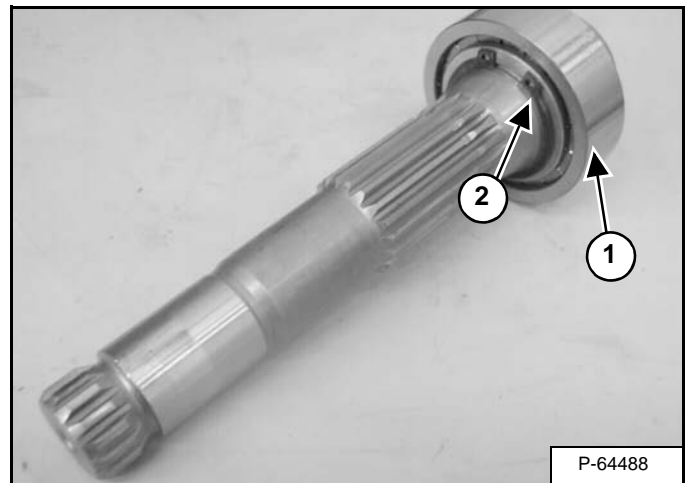

The drive shaft can be tapped out of the end housing with a rubber mallet.

Inspect wear surfaces for scratches, and inspect splines for excessive wear.

Inspect bearing (Item 1); if bearing needs replacement, remove snap ring (Item 2) [Figure 30-51-56] and remove bearing.

## DRIVE BELT

### Belt Adjustment

The drive belt does not need adjustment. The belt has a spring loaded idler which constantly maintains the correct belt tension.

### Belt Replacement

Stop the engine and open the rear door.

Remove the battery. (See Removal And Installation on Page 60-20-1.)

**Figure 30-60-1**

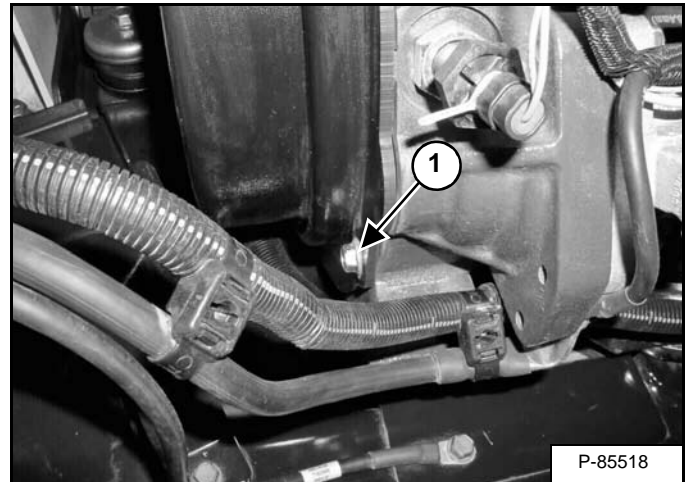

Remove the drive belt shield bolt (Item 1) [Figure 30-60-1].

**Figure 30-60-2**

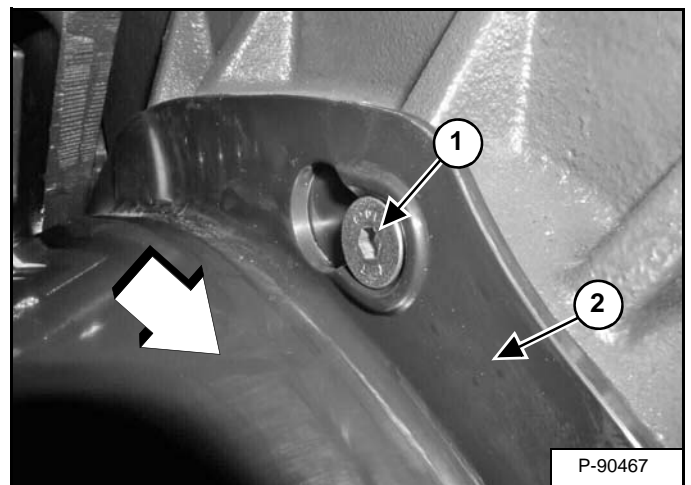

Do **NOT** loosen the drive belt shield mounting bolts (top bolt shown) (Item 1). Slide the drive belt shield (Item 2) toward the back of the loader to unseat the shield from the top and bottom drive belt shield mounting bolts. Remove the drive belt shield (Item 2) [Figure 30-60-2].

## TWO-SPEED / BRAKE VALVE (CONT'D)

### Valve Block Disassembly And Assembly (Cont'd)

Figure 30-70-10

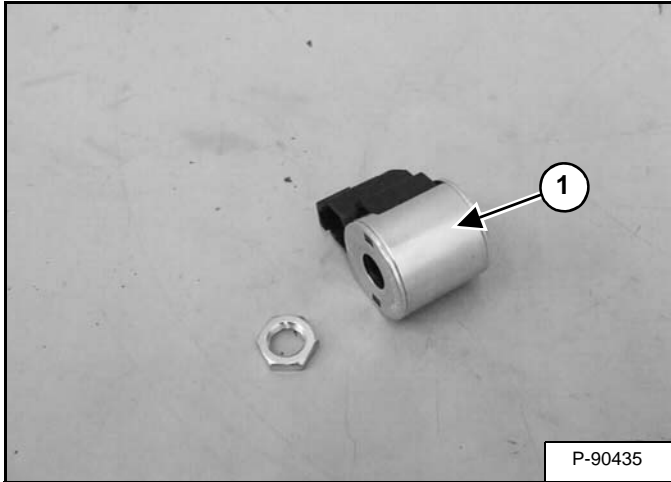

Use a test meter and test the solenoid coils (Item 1) [Figure 30-70-10] for resistance.

The resistance value for the solenoid coil can be found on the electrical schematic.

Figure 30-70-11

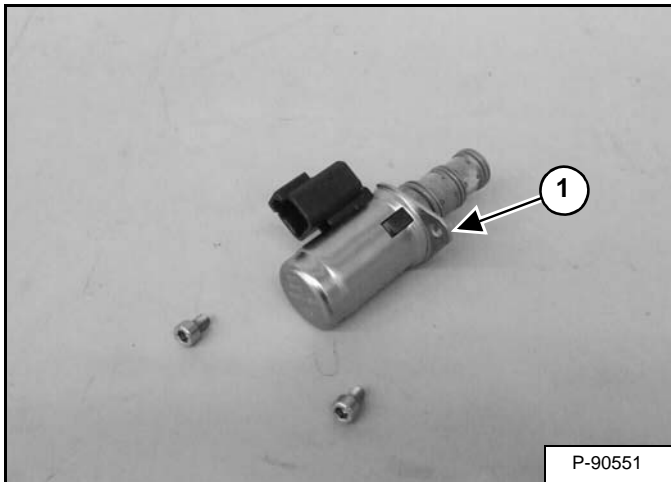

Use a test meter and test the solenoid coils (Item 1) [Figure 30-70-10] for resistance.

The resistance value for the solenoid coil can be found on the electrical schematic.

**Assembly:** Always install new O-rings [Figure 30-70-10].

Figure 30-70-12

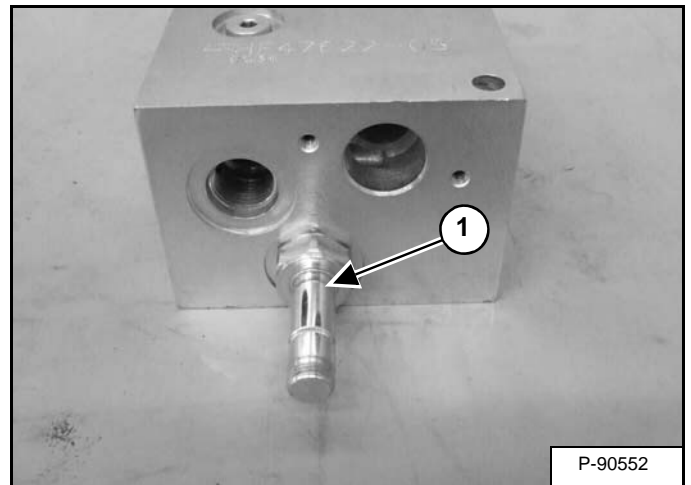

Remove the make-up solenoid (Item 1) [Figure 30-70-12] from the valve block.

Figure 30-70-13

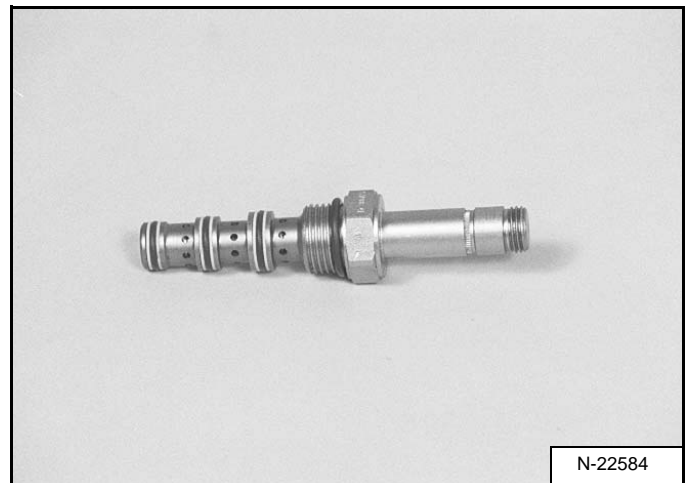

**Assembly:** Always install new O-rings and back-up washers [Figure 30-70-13]. Tighten the solenoid valve to 27,1 N•m (20 ft-lb) torque.

## DRIVE COMPONENTS

### Description

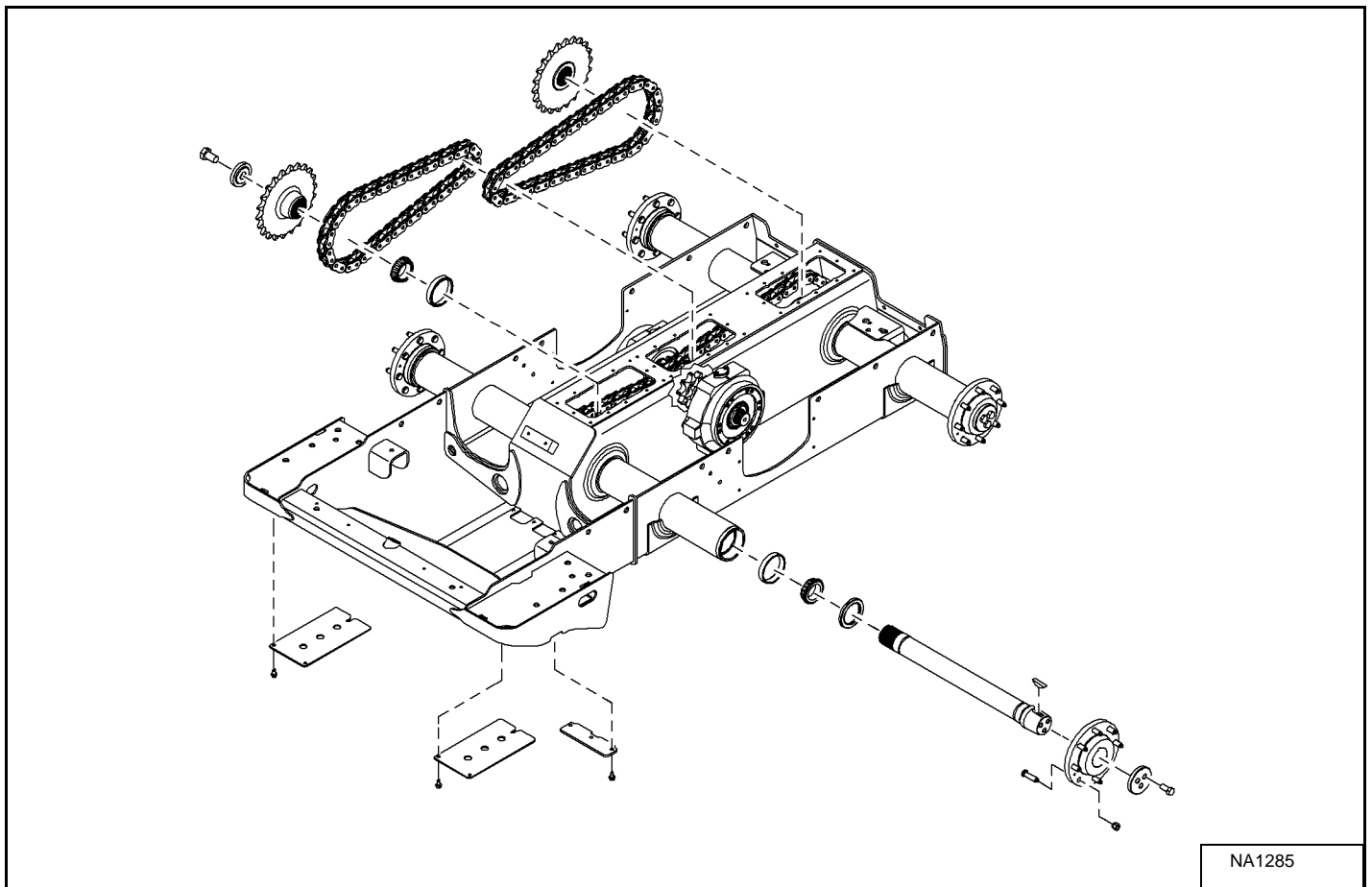

The drive components consist of the chaincase, drive chains, sprockets, axleshafts, hubs, drive motor carrier and a brake (Single speed only).

The two speed brake is part of the two speed drive motor.

The chaincase is partially filled with hydraulic fluid to lubricate the chains and bearings.

On the bottom of the chaincase, there is a cover for access to the fuel tank drain plug.

## CHAINCASE

### Description

The chaincase contains the drive components.

### Front Cover Removal And Installation

Raise the loader lift arms and install an approved lift arm support device. (See Installing on Page 10-20-1.)

Raise the loader operator cab. (See Raising on Page 10-30-2.)

Remove the control panel. (See Removal And Installation on Page 50-100-2.)

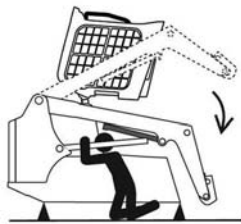

P-90328

### AVOID DEATH

- Disconnecting or loosening any hydraulic tubeline, hose, fitting, component or a part failure can cause lift arms to drop.
- Keep out of this area when lift arms are raised unless supported by an approved lift arm support. Replace if damaged.

D-1009-0409



Never work on a machine with the lift arms up unless the lift arms are secured by an approved lift arm support device. Failure to use an approved lift arm support device can allow the lift arms or attachment to fall and cause injury or death.

W-2059-0598

Figure 40-30-1

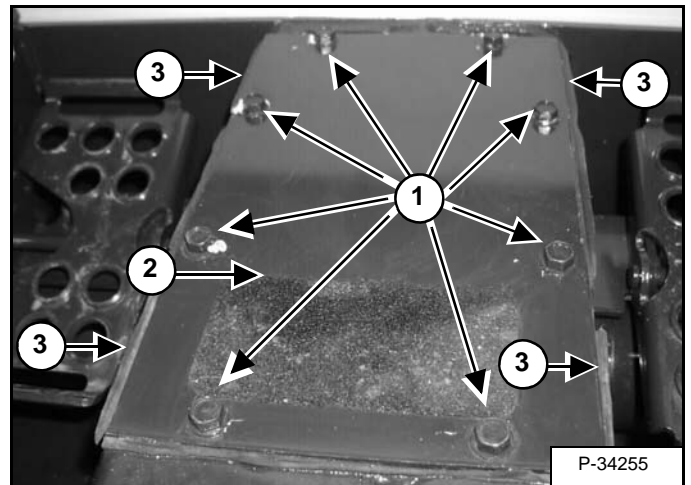

Remove the front chaincase cover mounting screws (Item 1) [Figure 40-30-1].

Remove the front chaincase cover (Item 2) [Figure 40-30-1] from the loader.

**NOTE:** There are tabs (Item 3) [Figure 40-30-1] on the side of the cover to help pry the covers off.

**Installation:** Apply polyurethane sealer to mating surfaces. Polyurethane sealant should be applied to the screw threads to stop oil leakage. Tighten the mounting screws to 34 - 38 N•m (25 - 28 ft-lb) torque.

## SEAT BAR (CONT'D)

### Compression Spring Disassembly And Assembly

Figure 50-10-8

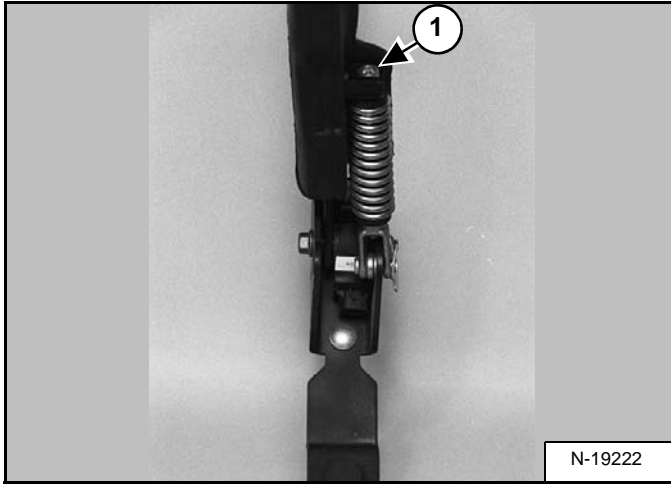

Turn the bolt (Item 1) [Figure 50-10-8] and [Figure 50-10-9] out of the clevis.

**Assembly:** Apply Loctite® #518 adhesive to the bolt threads. Adjust the compression spring by turning the bolt in past the end of the clevis three turns.

**NOTE:** For procedures requiring the use of Loctite® #518 adhesive, thoroughly clean and dry affected parts before the application of Loctite® #518.

Figure 50-10-9

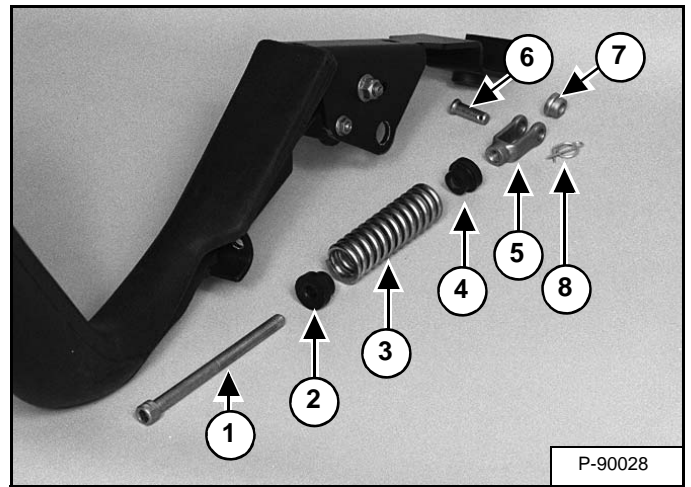

Disassemble and assemble the seat bar compression spring and parts as shown in [Figure 50-10-9].

- Bolt (Item 1)
- Bushing (Item 2)
- Spring (Item 3)
- Bushing (Item 4)
- Clevis (Item 5)
- Pin (Item 6)
- Bushing (Item 7)
- Rue Ring (Item 8)

## OPERATOR SEAT (SUSPENSION) (CONT'D)

### Lower Cushion Installation

Figure 50-31-7

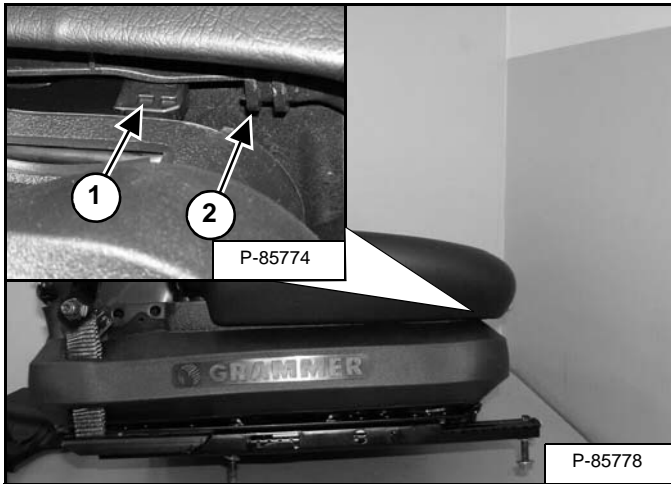

Insert the tab (Item 1) into the slot (Item 2) [Figure 50-31-7].

Figure 50-31-8

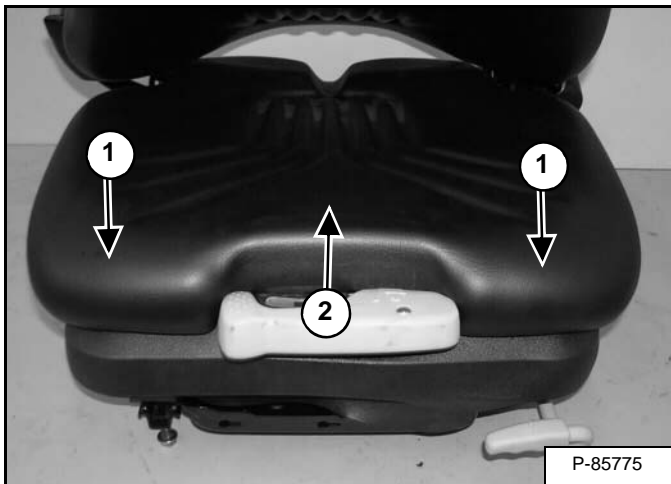

Push down on the front of the seat (Item 1) and push back (Item 2) [Figure 50-31-8] to lock the seat into position.

### Back Cushion Removal And Installation

Figure 50-31-9

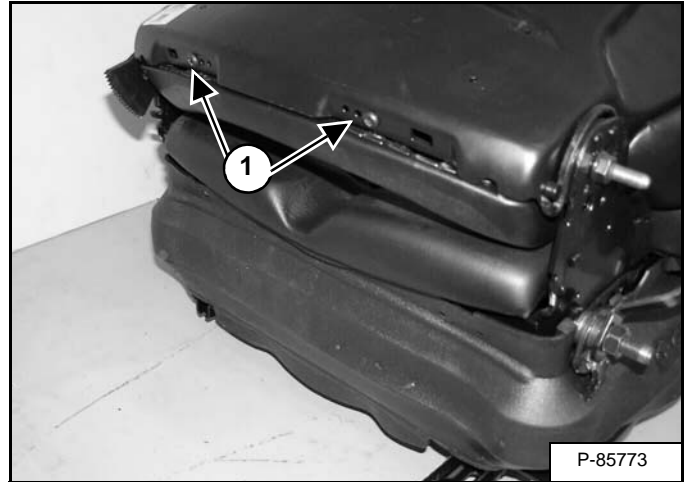

Tilt the seat all the way forward.

Remove the two screws (Item 1) [Figure 50-31-9] and tilt the seat back to the upright position.

Remove the back cushion from the seat

## BOB-TACH (POWER)

### Description

The Bob-Tach is the section of the loader lift arm that attachments mount to. The Power Bob-Tach option uses two hydraulically operated, spring assisted, locking wedge and lever assemblies to secure the attachment to the Bob-Tach.

The hydraulically operated Power Bob-Tach has a hydraulic cylinder that opens and closes both wedge and lever assemblies by pressing a switch on the right switch panel. The switch activates the Power Bob-Tach block to allow flow into or out of the hydraulic cylinder connected to the levers on the Bob-Tach.

The Power Bob-Tach block is located on the rear of the gear pump.

The Bob-Tach is located on the front of the loader connected to the loader lift arms.

## Removal And Installation

Figure 50-41-1

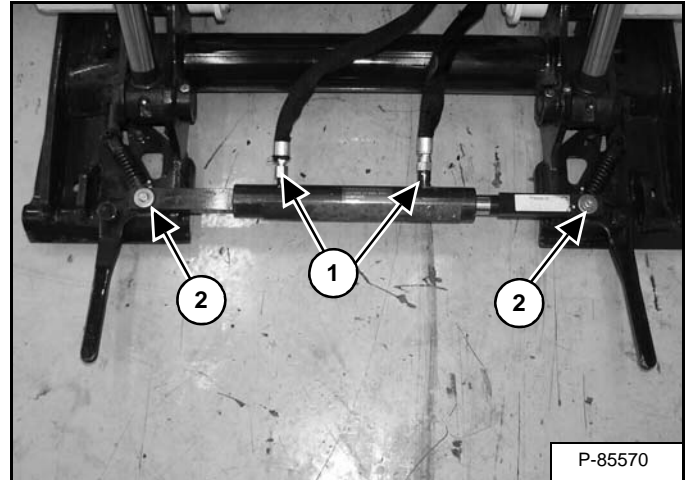

Tilt the Bob-Tach forward, so it is parallel to the floor. Put 2x4 blocks under each side of the Bob-Tach [Figure 50-41-1].

Lower the Bob-Tach onto the blocks.

Mark the hoses (Item 1) [Figure 50-41-1] for correct installation.

Remove and cap the hoses from the cylinder.

Remove the washers and bolts (Item 2) [Figure 50-41-1] from the cylinder (both ends).

**Installation:** Tighten the retainer nut to 48 - 54 N•m (35 - 40 ft-lb) torque.

Remove the cylinder from the Bob-Tach.

## LIFT ARMS (CONT'D)

### Removal And Installation (Cont'd)

Figure 50-50-16

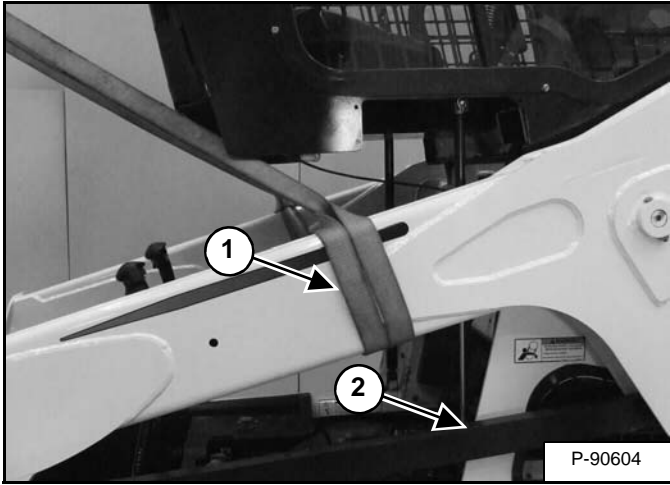

**NOTE:** Be sure the slings on the lift arms are in a position to balance the lift arms when being removed. See (Item 1) [Figure 50-50-16].

Disconnect the stabilizer bar from both sides of the lift arms (Item 2) [Figure 50-50-16].

Figure 50-50-17

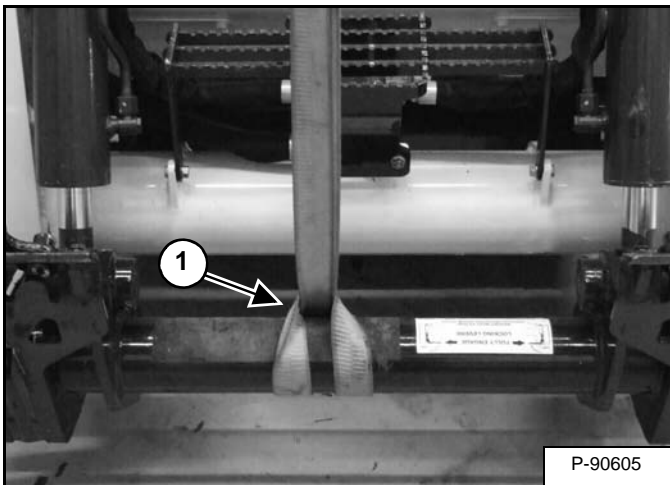

Position the front sling in the middle of the Bob-Tach as shown in (Item 1) [Figure 50-50-17].

Support the lift arms with the chain hoist.

Figure 50-50-18

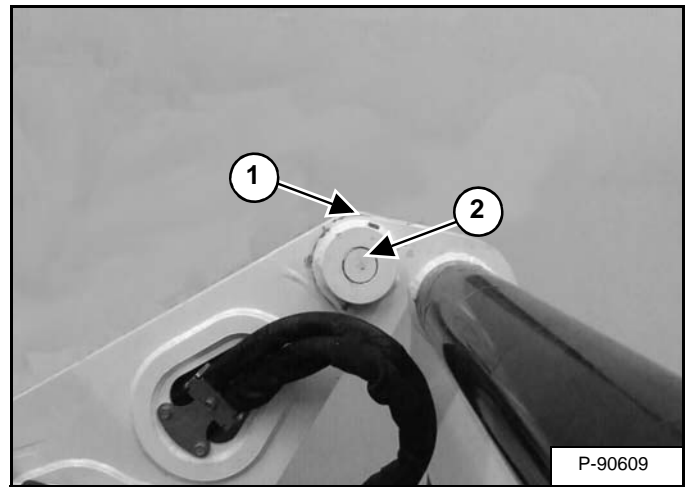

Remove the retaining bolt and nut (Item 1) and the pin (Item 2) [Figure 50-50-18] (both sides).

**Installation:** Tighten the retainer bolt and nut to 48 - 54 N•m (35 - 40 ft-lb) torque.

Remove the lift arms from the loader.

CLICK HERE TO **DOWNLOAD** THE COMPLETE MANUAL

- Thank you very much for reading the preview of the manual.
- You can download the complete manual from: [www.heydownloads.com](http://www.heydownloads.com) by clicking the link below



- Please note: If there is no response to CLICKING the link, please download this PDF first and then click on it.

CLICK HERE TO **DOWNLOAD** THE COMPLETE MANUAL

## FUEL TANK (CONT'D)

### Fuel Level Sender Removal And Installation

Figure 50-80-9

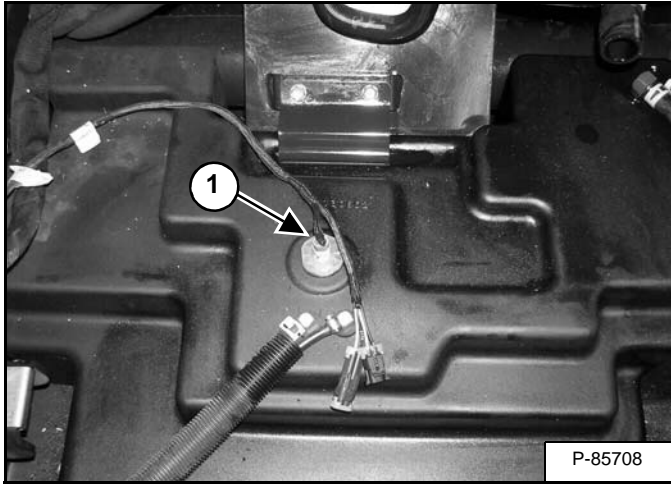

Disconnect the wire harness connector (Item 1) [Figure 50-80-9] from the fuel level sender.

Remove the fuel level sender.

Figure 50-80-10

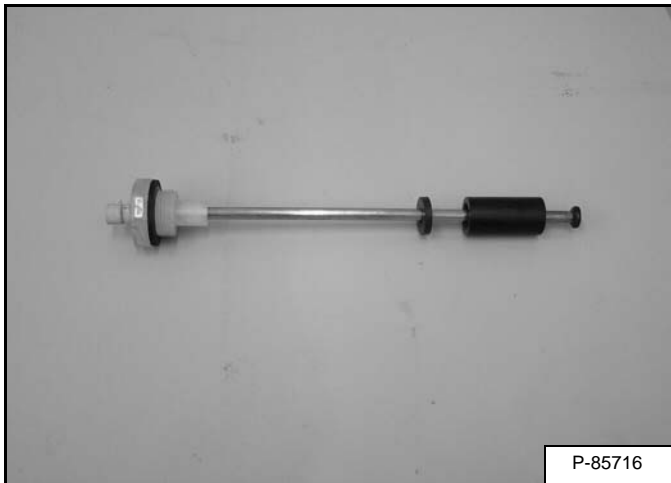

Inspect the fuel level sender and replace if worn or damaged.

### Fuel Fill Screen Removal And Installation

Figure 50-80-11

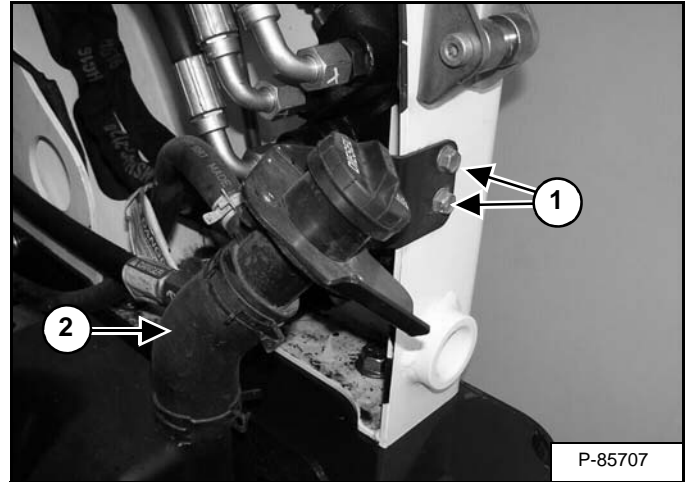

Remove the two bolts (Item 1) and disconnect the fuel fill hose (Item 2) [Figure 50-80-11].

Figure 50-80-12

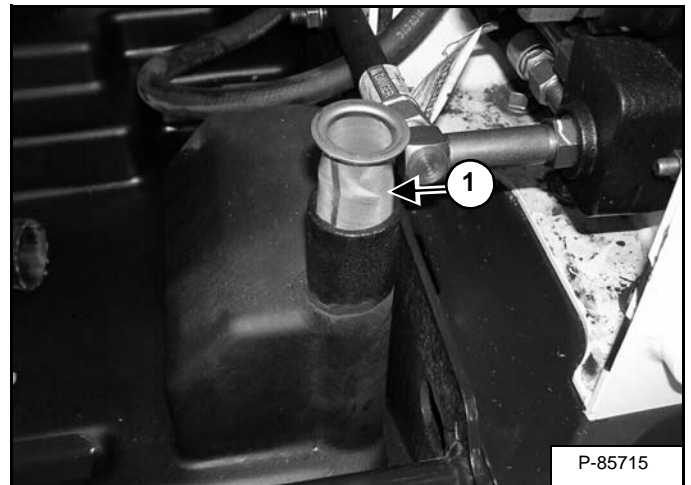

Remove the fuel fill screen (Item 1) [Figure 50-80-12].

Inspect and replace as needed.

## CONTROL PANEL

### Description

Figure 50-100-1

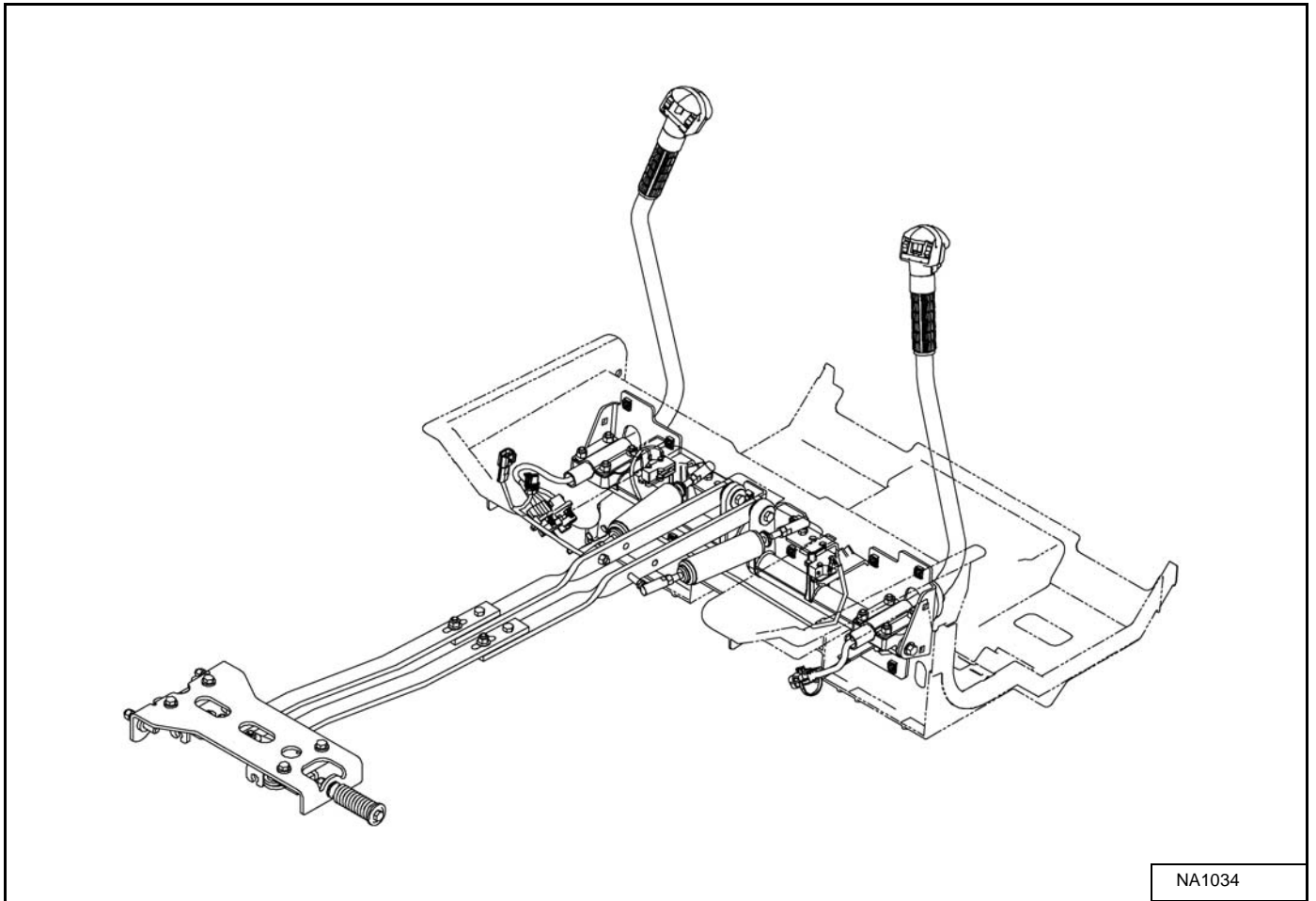

The steering system consists of independent steering levers the operator uses to provide steering input to the loader.

The steering levers are attached to pivoting bellcranks that pivot on a steering shaft and plastic bushings.

The forward travel is adjusted by drift adjustment bolts.

The bellcranks are attached to steering linkage bars with torsion bushings pressed into the bellcranks. Bellcranks mount to the control handle assembly and mount to the control panel.

Steering linkage bars are a two-piece design. Steering linkage bars are adjustable in length for "full travel adjustment".

Steering linkage bars attach to the pintle arms where a rubber torsion bushing is pressed into the pintle arms.

Pintle arms are of a two-piece design that allow easy adjustment of the neutral or "creep".

The steering system returns the levers to their starting position by means of the centering spring and the returning force of the torsion bushings.

**NOTE: Torsion bushings need to be replaced if torn or rotating in the housing. Loosen torsion bushing bolts slightly before adjustments are made.**

Sequence of steering adjustments:

1. Set neutral of pintle arms, "creep"
2. Set full travel at steering linkage bars
3. Set drift at drift adjustment bolts

## CONTROL PANEL (CONT'D)

### Linkage Neutral (Adjusting) (Cont'd)

Figure 50-100-28

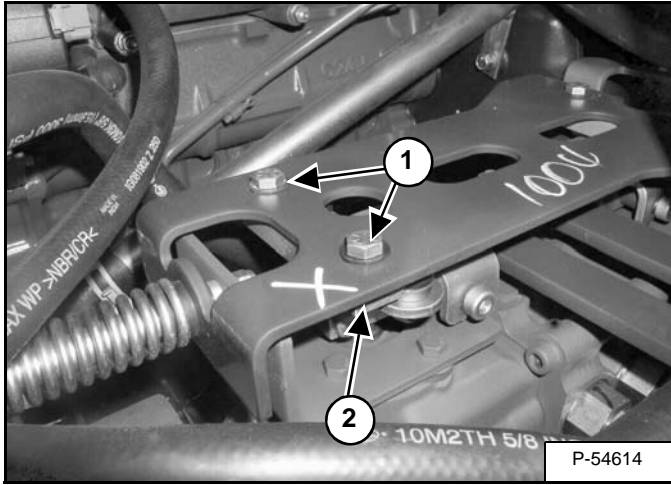

Loosen the two bolts (Item 1) holding the right centering block. Move the right hand centering block (Item 2) [Figure 50-100-28] until both pintle cams contact the centering block.

**NOTE:** The left centering block is not adjustable. By adjusting the right centering block the left centering block will also become aligned properly.

Figure 50-100-29

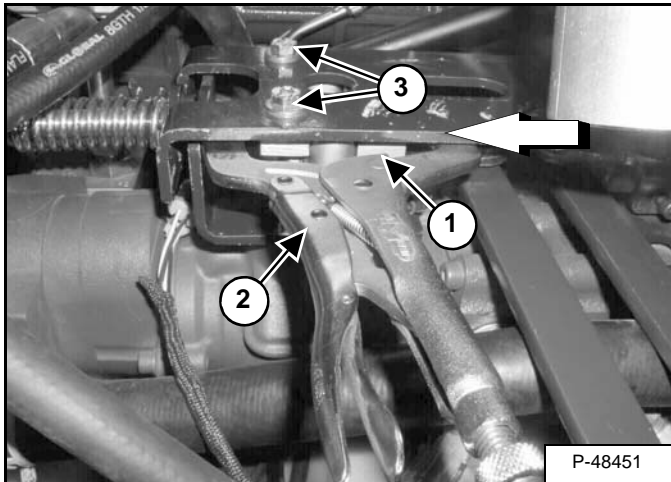

A modified locking grip C-Clamp and steering block shown in [Figure 50-100-25] may be used to help in aligning the centering blocks.

Install the centering block (Item 1) on the inside of the pintle cams and the C-Clamp (Item 2) [Figure 50-100-29] around both centering blocks.

Lock the C-Clamp in place.

## **WARNING**

Put jackstands under the front axles and rear corners of the frame before running the engine for service. Failure to use jackstands can allow the machine to fall or move and cause injury or death.

W-2017-0286

Connect the Remote Start Tool (Service Tool) to the loader. (See REMOTE START TOOL KIT-MEL1563 on Page 10-60-1.) OR (See REMOTE START TOOL (SERVICE TOOL) KIT - 7003031 on Page 10-61-1.)

Start the engine and run at low idle.

Move the traction lock override switch so the traction function is unlocked. On a standard loader the wedge brake will unlock.

**NOTE:** When the engine is started, the wheels / tracks may begin to move.

**NOTE:** In loaders equipped with manual steering and hydraulic brake, the steering levers may have to be moved during engine start-up to reduce the amount of creep. This reduction in creep will allow time for the engine to run and build up hydraulic charge pressure, which will release the hydraulic brake.

Tighten bolts (Item 3) [Figure 50-100-29] to 47,5 - 54,2 N•m (35 - 40 ft-lb).

**NOTE:** Check for slack between centering blocks and pintle cams. If there is excessive slack repeat above steps [Figure 50-100-28] & [Figure 50-100-29].

## CONTROL HANDLE / LEVER

### Description

The control handles / levers are used to control the forward and reverse travel.

The control handles / levers are mounted to the control panel assembly.

### Lever Removal And Installation

Figure 50-110-1

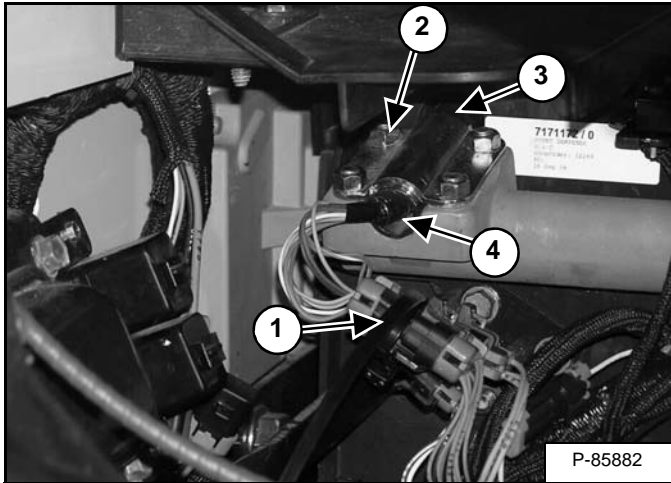

Remove the tie strap and disconnect the electrical connectors (Item 1) [Figure 50-110-1] from the control lever.

Remove the four nuts (Item 2) and the plate (Item 3) [Figure 50-110-1] used to mount the control lever.

Remove the control lever (Item 4) [Figure 50-110-1] by sliding the lever through the control panel.

**Installation:** Tighten the four nuts to the plate so the lever cannot be moved either right or left when seated in the operator's seat.

## ACCESS PANEL (INSIDE)

### Removal And Installation (Left)

Remove the control pedal. (See Pedal Removal And Installation on Page 50-90-1.)

**Figure 50-120-1**

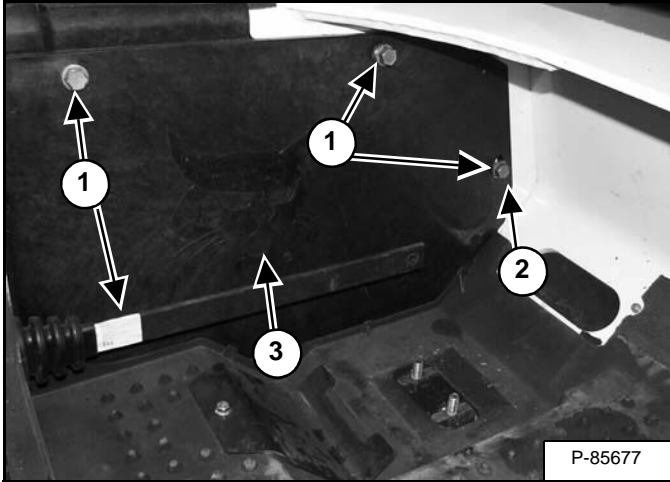

Remove the four mounting screws, (Item 1), washer (Item 2), and remove the left access panel (Item 3) **[Figure 50-120-1]**.

Remove the front access panel from the loader.

### Removal And Installation (Right)

Remove the control pedal. (See Pedal Removal And Installation on Page 50-90-1.)

**Figure 50-120-2**

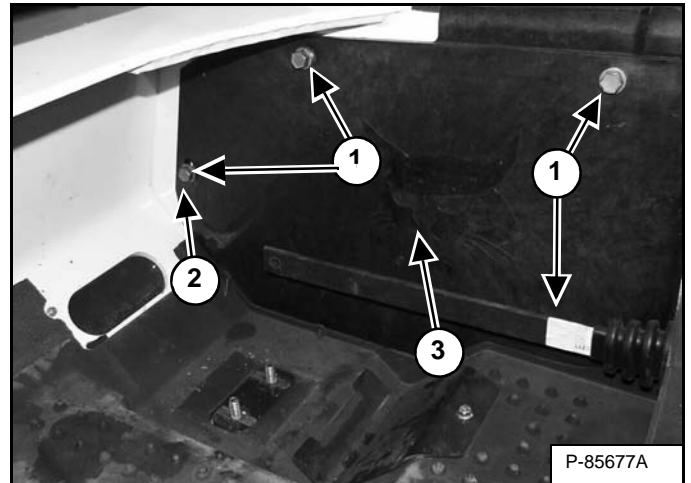

Remove the top mounting screw (Item 1), washer (Item 2), and loosen the two bottom mounting screws (Item 3) **[Figure 50-120-2]** from the front access panel.

Remove the front access panel from the loader.

## CAB DOOR

### Description

The standard cab door is available as an option or dealer installed kit.

### Removal And Installation

Figure 50-140-1

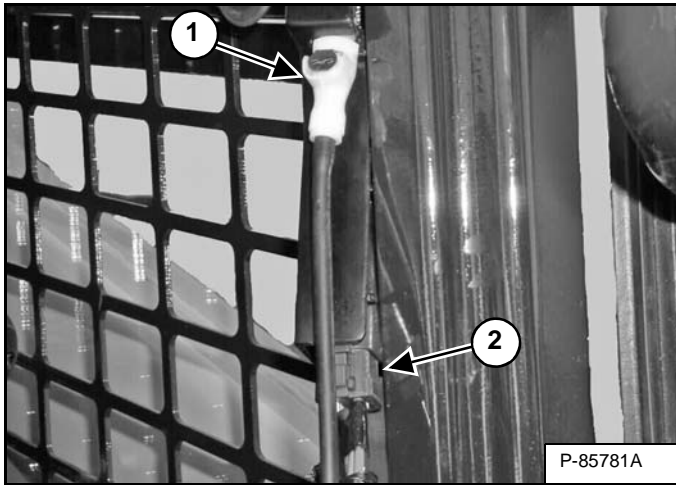

Open the cab door.

Disconnect electrical connector (Item 2) and washer fluid hose (Item 1) [Figure 50-140-1].

Figure 50-140-2

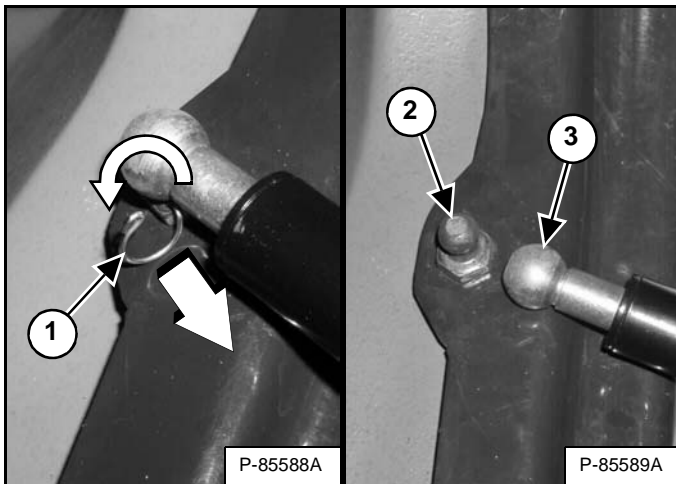

Rotate and pull the clip (Item 1) out of the gas spring socket. Pull the gas spring socket (Item 3) straight off the ball stud fitting (Item 2) [Figure 50-140-2].

Figure 50-140-3

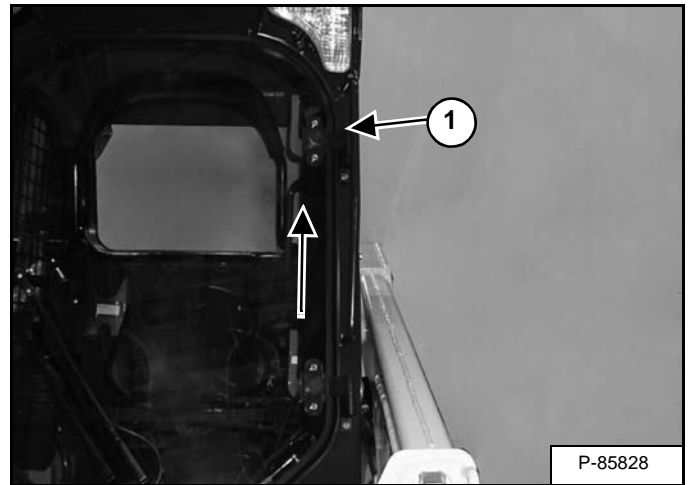

Lift the door (Item 1) [Figure 50-140-3] off the hinges.

Figure 50-140-4

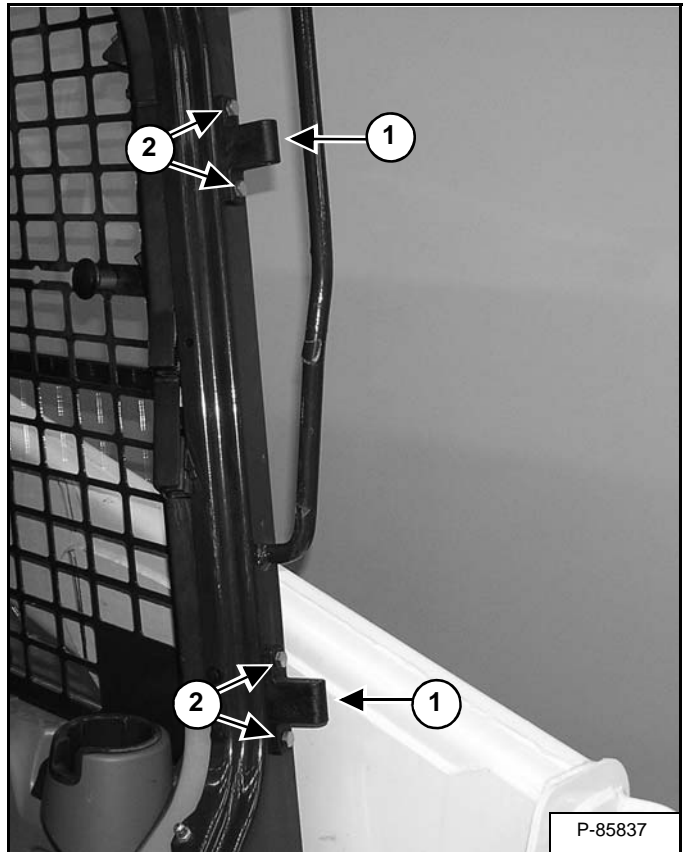

Remove the four bolts and nuts (Item 2) [Figure 50-140-4] from the cab.

Remove the hinges (Item 1) [Figure 50-140-4] from the cab.

**Installation:** Install the hinges (Item 1) on the cab and use the bolts and nuts (Item 2) [Figure 50-140-4] to secure the hinges. Tighten to 9,6 - 10,7 N•m (85 - 90 in-lb) torque.

## LEFT SIDE LOWER PANEL (CONT'D)

### Removal And Installation (Cont'd)

Figure 50-160-9

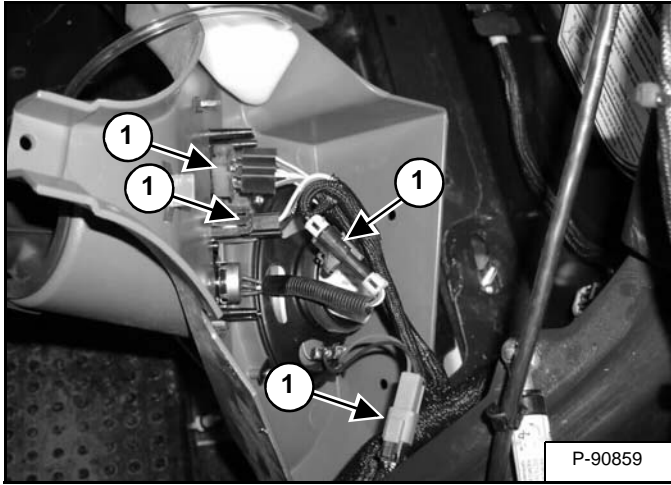

Disconnect the HVAC or radio wire harnesses (Item 1) [Figure 50-160-9] (if equipped).

## Disassembly And Assembly

Figure 50-160-10

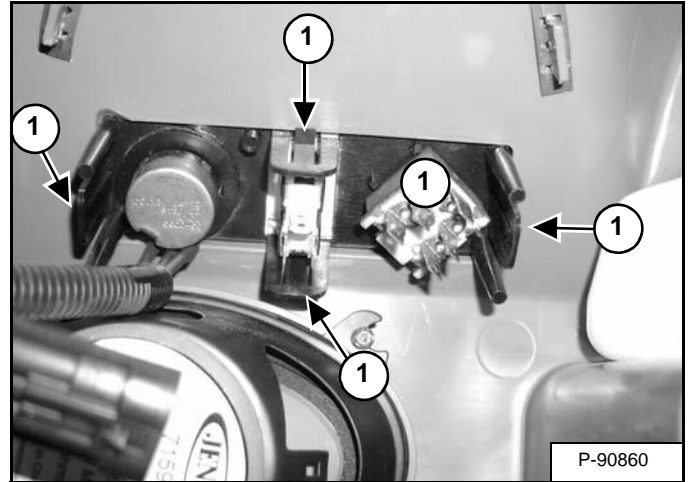

Press the four tabs (Item 1) [Figure 50-160-10] and remove the HVAC control out of the left side lower panel.

Figure 50-160-11

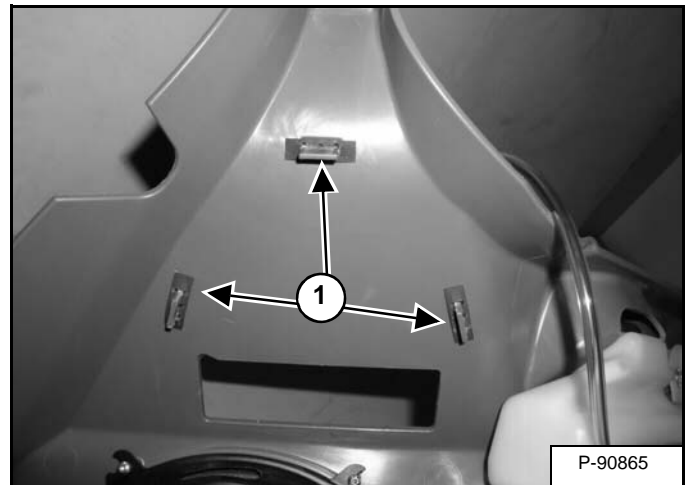

**NOTE:** If the three clips (Item 1) [Figure 50-160-11] are removed the cup holder will need to be replaced.

TRACTION LOCK .....	60-120-1
Description .....	60-120-1
Troubleshooting .....	60-120-2
Inspecting .....	60-120-3
CONTROL SYSTEM (ACS) .....	60-130-1
Description .....	60-130-1
Troubleshooting .....	60-130-2
Handle Sensor Connector Disassembly And Assembly .....	60-130-3
Switch Handle Removal .....	60-130-4
Switch Handle Installation .....	60-130-6
Actuator Connector Disassembly And Assembly .....	60-130-9
Handle Lock Solenoid Removal And Installation .....	60-130-10
Handle Lock Solenoid Disassembly And Assembly .....	60-130-10
Foot Sensor Removal And Installation .....	60-130-11
Foot Sensor Disassembly And Assembly .....	60-130-12
Foot Sensor Lock Solenoid Removal And Installation .....	60-130-12
ELECTRICAL / HYDRAULIC CONTROLS .....	60-140-1
Identification Chart .....	60-140-1
Description .....	60-140-2
Identification Chart ACD Group 0 .....	60-140-3
Identification Chart ACD Group 1 .....	60-140-4
Identification Chart ACD Group 2 .....	60-140-5
Identification Chart ACD Group 3 .....	60-140-6
ELECTRICAL / HYDRAULIC CONTROLS (ACS) .....	60-141-1
Identification Chart .....	60-141-1
Description .....	60-141-2
Identification Chart ACD Group 0 .....	60-141-3
Identification Chart ACD Group 1 .....	60-141-4
Identification Chart ACD Group 2 .....	60-141-5
Identification Chart ACD Group 3 .....	60-141-6
ELECTRICAL / HYDRAULIC CONTROLS (SJC) .....	60-142-1
Identification Chart .....	60-142-1
Description .....	60-142-2
Identification Chart ACD Group 0 .....	60-142-3
Identification Chart ACD Group 1 .....	60-142-4
Identification Chart ACD Group 2 .....	60-142-5
Identification Chart ACD Group 3 .....	60-142-6
SERVICE PC (LAPTOP COMPUTER) .....	60-150-1
Connecting Remote Start Tool .....	60-150-1
Connecting Remote Start Tool (Service Tool) .....	60-150-1



WIRE CATEGORIES FOR COLORS AND NUMBER RANGE			
GROUP DESCRIPTION	GROUP NUMBER RANGE	WIRE COLOR	COLOR CODE
BATT FEED, GENERAL	1000 THROUGH 1499	RED	RED
BATT FEED, FUSED	1000 THROUGH 1499	RED/WHITE	RED/WHT
BATT FEED, SWITCHED	1500 THROUGH 1999	ORANGE/WHITE	RNG/WHT
GROUNDING	2000 THROUGH 2999	BLACK	BLK
MONITORING	3000 THROUGH 3999	LIGHT BLUE	LBL
HYDRAULIC	4000 THROUGH 4999	LIGHT GREEN	LGN
ATTACHMENT CONTROLS	5000 THROUGH 5999	YELLOW	YEL
LIGHTS	6000 THROUGH 6999	PINK	PNK
ACCESSORIES	7000 THROUGH 7999	WHITE	WHT
ENGINE	8000 THROUGH 8999	TAN	TAN
COMMUNICATION	9000 THROUGH 9999	PURPLE	PUR
COMMUNICATION	9000 THROUGH 9999	PURPLE/WHITE	PUR/WHT

SCHEMATIC INDEX	
OVERVIEW	PAGE 1,2
POWER	PAGE 3
GROUND	PAGE 4
CAN BUS	PAGE 5
ENGINE	PAGE 6
HYDRAULICS	PAGE 7
CAB DISPLAY	PAGE 8
CABIN	PAGE 9
MANUAL CONTROLS	PAGE 10
LIGHTS	PAGE 11
HVAC	PAGE 12
OPTIONS	PAGE 13
ACS CONTROL	PAGE 14
SJC CONTROL	PAGE 15

# ENGINE

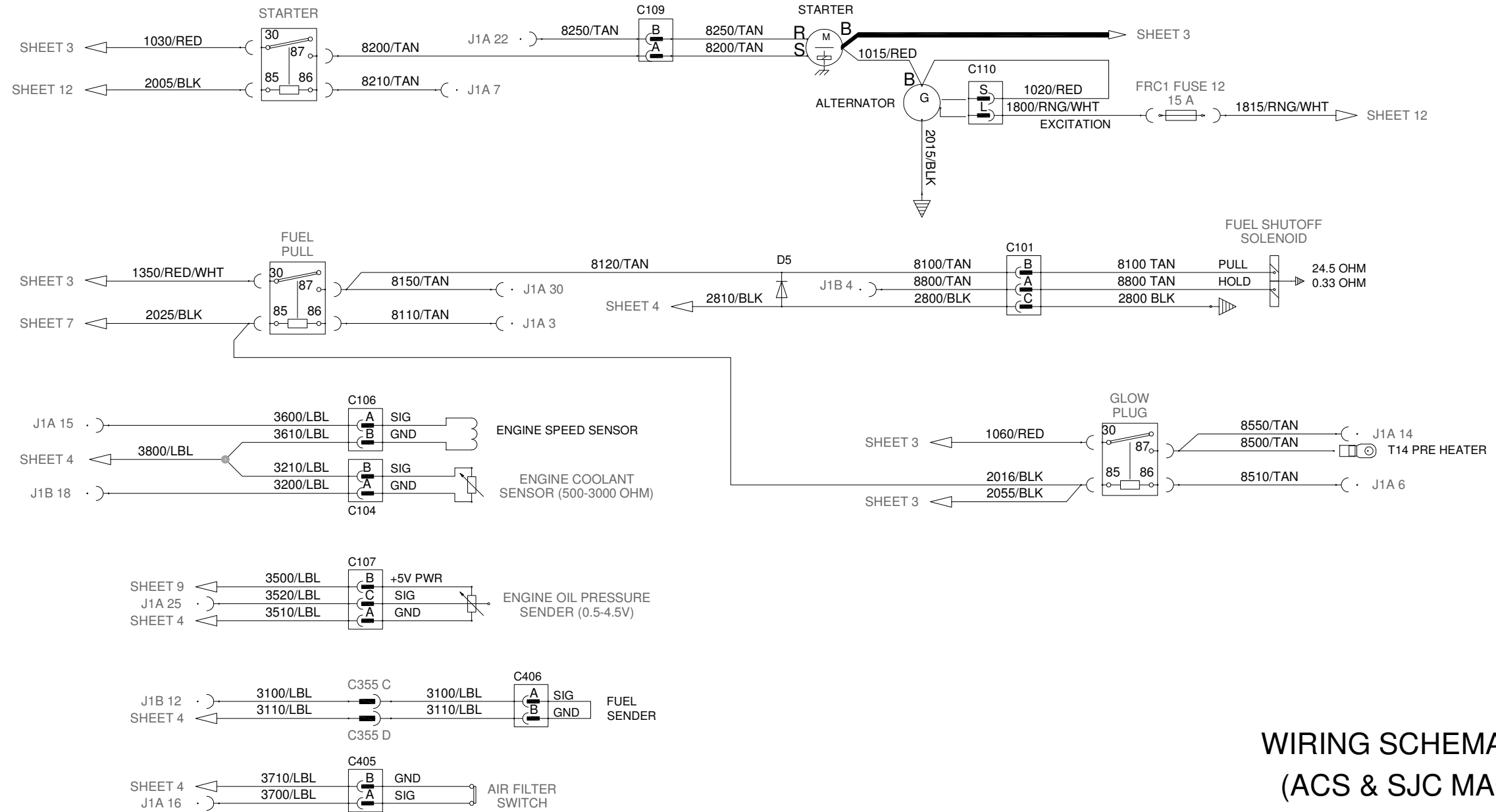









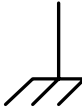
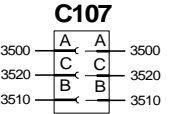
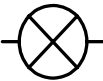
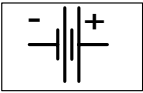

**WIRING SCHEMATIC**  
**(ACS & SJC MACHINE)**  
**S650 (S/N A3NV11001 AND ABOVE)**  
**(S/N A3NW11001 AND ABOVE)**  
 Sheet 6 of 15

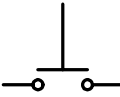
(PRINTED JUNE 2009)

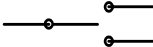
7171253

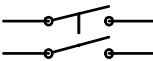
# ELECTRICAL SYSTEM INFORMATION

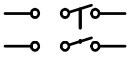
## Glossary Of Electrical Symbols

SYMBOL	DESCRIPTION	SYMBOL	DESCRIPTION
<b>CONNECTIONS</b>			
	<p><b>CONNECTOR - Harness</b> - Used for connecting 2 harnesses together or a harness to a component. The connector can vary from a single pin to any number of pins (Example: 3 pin connectors shown). The connector pins can be numbered alphabetical (shown) or numerical (1, 2, 3 etc.). The harness wires numbers are called out next to the connector (Example: 3500).</p>		<p><b>GROUND - Frame</b> - Used to represent an component that is internally grounded.</p>
	<p>The connector number is called out next to the connector (Example: C107). These connector numbers are used for schematic identification only and do not appear on the harness or connector.</p>		<b>LIGHT</b> -
<b>COMPONENTS</b>			
	<b>BATTERY</b> - Used for supplying and storing electrical power for the machine.		<b>SWITCH - Single Pole - Single Throw (ON-OFF) Normally Open</b>
	<b>POSITIVE ELECTRICAL CIRCUIT</b> - Indicates positive battery circuit.		<b>SWITCH - Single Pole - Single Throw (ON-OFF) Normally Closed.</b>
	<b>NEGATIVE ELECTRICAL CIRCUIT</b> - Indicates battery ground circuit.		<b>SWITCH - Single Pole - Double Throw (ON-OFF-ON)</b> - This switch can be in any of three positions. (Some switches are spring activated to return them to a certain position when released.)
	<b>ALTERNATOR</b> - Used to create the electrical current to supply voltage to the battery and components.		<b>SWITCH - Double Pole - Single Throw (ON-OFF)</b> Open and Closed positions will be specified depending on switch application.)
	<b>STARTER</b> - Uses battery current to start the machine engine.		<b>SWITCH - Double Pole - Double Throw (ON-OFF)</b> Open and Closed positions will be specified depending on switch application.
	<b>GROUND</b> - Used to represent an external ground connection.		<b>POTENTIOMETER</b> - Variable resistance - Provides variable resistance.

# ELECTRICAL SYSTEM (CONT'D)

## Fuse And Relay Location / Identification (Cont'd)

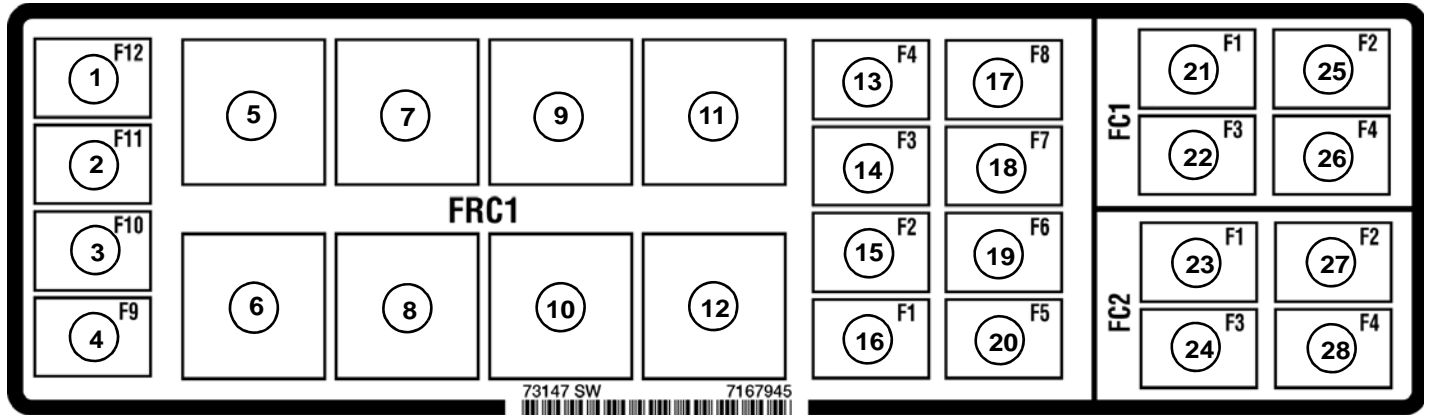

The location and amperage ratings are shown in the table below and on the decal above. Relays are identified by the letter “R” in the AMP column.

REF	ICON	DESCRIPTION	AMP	REF	ICON	DESCRIPTION	AMP	REF	ICON	DESCRIPTION	AMP
1		Alternator	15	11		Glow Plugs	R	21		Bobcat Controller	25
2		Heater / HVAC	25	12		Fuel Shutoff	R	22		ACS Controller	25
3		Front Lights	20	13		Cab Switched Power	5	23		Attachments	25
4		Rear Lights	15	14		Bucket Position	15	24		Not Used	--
5		Starter	R	15		Wiper / Washer	25	25		Auxiliary Controller	25
6		Front Lights	R	16		Switched Power & Back-up Alarm (Standard/ACS)	25	26		Drive Controller & Back-up Alarm (SJC)	25
7		Heater / HVAC	R	17		Switched Power	25	27		Accessories & Front Horn	25
8		Rear Lights	R	18		Switched Power	25	28		Power Port	15
9		Switched Power	R	19		Traction	30				
10		Traction	R	20		Fuel Shutoff	30				

## ALTERNATOR (CONT'D)

### Removal And Installation

Remove the air conditioning belt. (See Compressor Drive Belt Replacement on Page 80-20-2.)

# IMPORTANT

Damage to the alternator can occur if:

- Engine is operated with battery cables disconnected.
- Battery cables are connected when using a fast charger or when welding on the loader. (Remove both cables from the battery.)
- Extra battery cables (booster cables) are connected wrong.

I-2023-1285

Figure 60-30-9

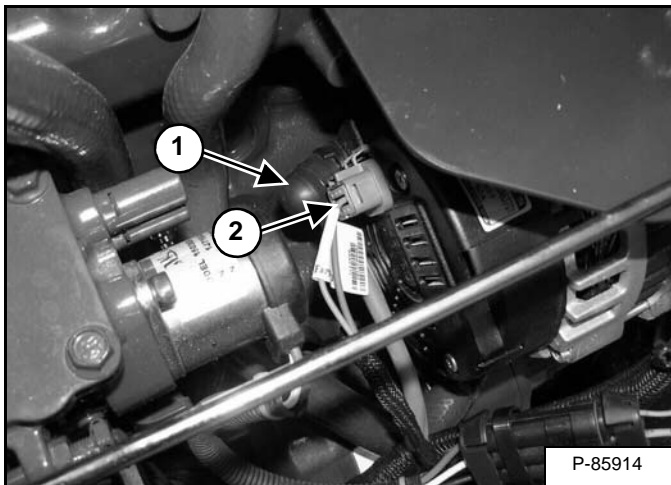

Disconnect the negative (-) cable from the battery.

Disconnect the red wire (Item 1) [Figure 60-30-9] from the alternator which comes from the battery.

Disconnect the wiring harness connector (Item 2) [Figure 60-30-9] from the alternator.

Figure 60-30-10

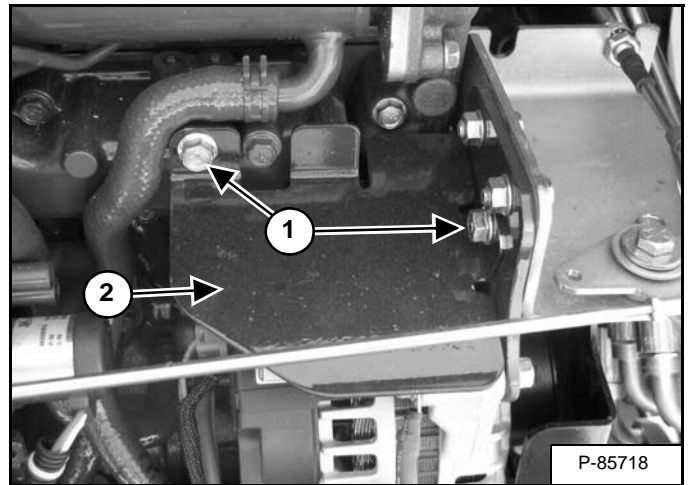

Remove the alternator rain shield mounting nut and bolts (Item 1) and remove the alternator rain shield (Item 2) [Figure 60-30-10].

Figure 60-30-11

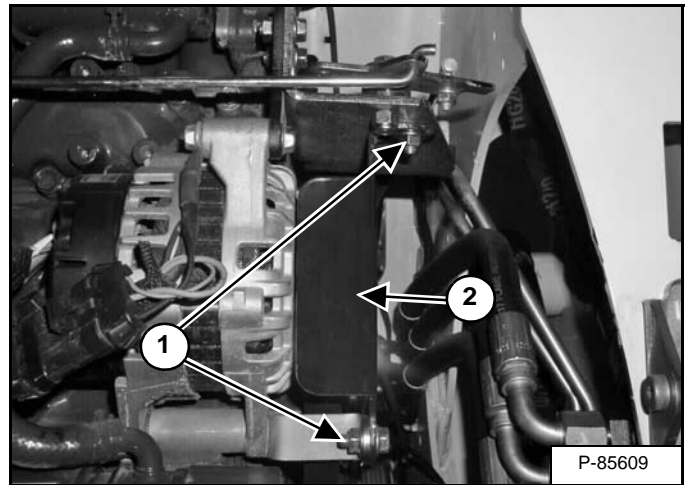

Remove the belt shield mounting nuts and bolts (Item 1) and remove the belt shield (Item 2) [Figure 60-30-11].

## INSTRUMENT PANEL IDENTIFICATION (CONT'D)

### Right Panel (Deluxe Instrumentation Panel) (Cont'd)

Figure 60-50-6



The first screen you will see on your new loader will be as shown in **[Figure 60-50-6]**.

When this screen is on the display you can enter the password and start the engine or change the default language.

**NOTE: Your new loader (with Deluxe Instrumentation Panel) will have an Owner Password. Your dealer will provide you with this password. Change the password to one that you will easily remember to prevent unauthorized use of your loader. Keep your password in a safe place for future needs.**

#### *Change Language:*

Press the left or right scroll button to cycle through the languages. The language that is stopped on will be the default language used for the deluxe instrumentation panel **[Figure 60-50-6]**.

The language can be changed at any time. (See CONTROL PANEL SETUP on Page 60-180-1.)

#### *Enter The Password:*

Use the numbers on the keypad to enter the password. Then press the **[Enter]** button a symbol will appear on the display screen for each number entered **[Figure 60-50-6]**. The left scroll button can be used to backspace if an incorrect number is entered.

If the correct password is not entered, **[INVALID PASSWORD TRY AGAIN]** will appear on the display screen and the password will have to be reentered.

See CONTROL PANEL SETUP for further description of screens to setup the system for your use. (See CONTROL PANEL SETUP on Page 60-180-1.)

**BOBCAT CONTROLLERS (GATEWAY AND AUXILIARY) (CONT'D)**

**Connector Identification (Cont'd)**

J1A

PIN	WIRE NUMBER	COLOR	DESCRIPTION
1	2410	BLACK	HYD LOCK VALVE SOLENOID GROUND
2	2380	BLACK	LIFT SPOOL SOLENOID GROUND
3	8110	TAN	FUEL RELAY SIGNAL
4	8000	TAN	SWITCHED POWER RELAY SIGNAL
5	6320	PINK	MRKR LIGHT PWR RELAY SIGNAL
6	8510	TAN	GLOW PLUG RELAY SIGNAL
7	8210	TAN	STARTER RELAY SIGNAL
8	4110	LGN	TRACTION LOCK RELAY SIGNAL
9	OPEN	NA	NA
10	2370	BLACK	TILT SPOOL LOCK SOLENOID GROUND
11	7023	WHITE	AC SIGNAL MONITOR
12	OPEN	NA	NA
13	4150	LGN	TRACTION LOCK RELAY FEEDBACK
14	8550	TAN	GLOW PLUG RELAY FEEDBACK
15	3600	LBL	ENGINE SPEED SENSOR SIGNAL
16	3700	LBL	AIR FILTER SENDER SIGNAL
17	6210	PINK	REAR LIGHT RELAY SIGNAL
18	2910	BLACK	HYDRAULIC FAN GROUND
19	9370	PURPLE	PTOL LED
20	9380	PURPLE	PTOL SWITCH
21	8020	TAN	SWITCHED POWER RELAY FEEDBACK
22	8250	TAN	STARTER RELAY FEEDBACK
23	3440	LBL	HYD FAN DIFF PRESS SWITCH SIGNAL
24	9360	PURPLE	START ENGINE
25	3520	LBL	ENGINE OIL PRESS SENDER POWER
26	2350	BLACK	TWO SPEED GROUND
27	2360	BLACK	TWO SPEED MAKEUP GROUND
28	6230	PINK	REAR LIGHT RELAY FEEDBACK
29	OPEN	NA	NA
30	8150	TAN	FUEL RELAY FEEDBACK
31	6330	PINK	MRKR LIGHT PWR RELAY FEEDBACK
32	3300	LBL	HYD TEMP SIGNAL
33	OPEN	NA	NA
34	3430	LBL	HYD FILTER DIFF PRESS

## BOBCAT CONTROLLER (SJC) (DRIVE)

### Description

The drive controller is only on loaders equipped with the SJC option. This controller processes information for the drive functions.

The drive controller is located behind the right side access panel near the operator's right foot.

The drive controller monitors the position of the left joystick, pump swash plate angles and the output of the wheel speed sensors.

The drive controller works along with the ACS controller and communicates with the main Bobcat controller in an SJC system. All these controllers are capable of software upgrades.

The SJC system uses electronic joysticks to control both of the workgroups (lift and tilt) and the drive functions of the loader. The control can be switched from ISO and H-Pattern drive control layouts.

The workgroup actuators are the same as those used on the ACS system.

The hydrostatic drive pump is a Rexroth A22 unit. It has two electromagnetic coils on each of the two pumps to control the drive of the loader. The coils will direct the forward and reverse outputs of the pump to the drive motors. The Rexroth pump is equipped with position sensors mounted to the bottom of the swash plates to provide feedback to the controllers to sense uncommanded swash plate movement.

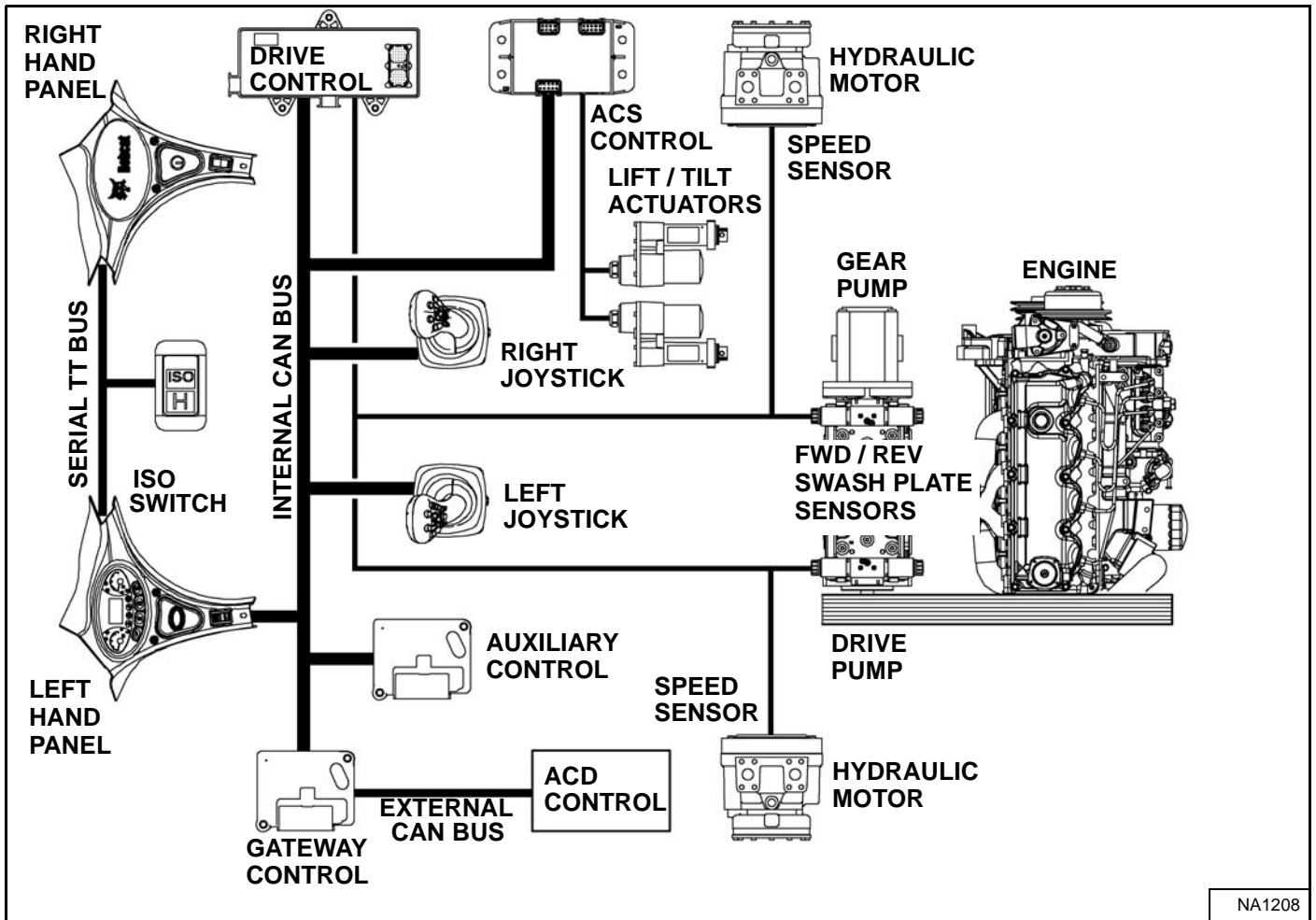

## DIAGNOSTIC SERVICE CODES (CONT'D)

### Service Codes List (Cont'd)

CODE	DESCRIPTION	CODE	DESCRIPTION
D7521	Left joystick Y-axis out of range high	D7572	Drive pump not calibrated
D7522	Right joystick Y-axis out of range high	D7573	Operating mode switch flipped while operating
D7523	Right front wheel angle sensor out of range high	D7574	Right wheel speed uncommanded motion
D7524	Left front wheel angle sensor out of range high	D7575	Left wheel speed uncommanded motion
D7525	Right rear wheel angle sensor out of range high	D7576	No communication from ACS controller
D7526	Left rear wheel angle sensor out of range high	D7577	Left speed sensor out of range high
D7527	Left swash plate out of position	D7578	Right speed sensor out of range high
D7528	Right swash plate out of position	D7579	Left speed sensor out of range low
D7529	Left joystick X-axis out of range low	D7580	Right speed sensor out of range low
D7531	Left joystick Y-axis out of range low	D7581	Right front steer retract short to battery
D7532	Right joystick Y-axis out of range low	D7582	Left front steer retract short to battery
D7533	Right front wheel angle sensor out of range low	D7583	Right rear steer retract short to battery
D7534	Left front wheel angle sensor out of range low	D7584	Left rear steer retract short to battery
D7535	Right rear wheel angle sensor out of range low	D7585	Sensor supply 1 out of range high
D7536	Left rear wheel angle sensor out of range low	D7586	Sensor supply 2 out of range high
D7537	Sensor supply 1 out of range low	D7587	Software update required
D7538	Sensor supply 2 out of range low	D7588	Switched power stuck ON
D7539	Left swash plate sensor out of range high	D7589	Switched power error OFF
D7540	Left swash plate sensor out of range low	D7591	Left swash plate sensor reversed
D7541	Right swash plate sensor out of range high	D7592	Right swash plate sensor reversed
D7542	Right swash plate sensor out of range low	D7593	Right speed sensor unresponsive
D7543	Left forward drive solenoid error ON	D7594	Left speed sensor unresponsive
D7544	Left reverse drive solenoid error ON	D7595	Left speed sensor reversed
D7545	Right forward drive solenoid error ON	D7596	Right speed sensor reversed
D7546	Right reverse drive solenoid error ON	D7597	Controller programmed
D7547	Right front steer extend short to battery	D7598	In drive calibration mode
D7548	Left front steer extend short to battery	D7599	In angle calibration mode
D7549	Right rear steer extend short to battery		
D7550	Left rear steer extend short to battery	H1221	Right Primary out of range high
D7551	Steer pressure short to battery	H1222	Right Primary out of range low
D7552	Back-up alarm error ON	H1224	Right Primary not in neutral
D7553	Left forward drive solenoid error OFF	H1321	Left Primary out of range high
D7554	Left reverse drive solenoid error OFF	H1322	Left Primary out of range low
D7555	Right forward drive solenoid error OFF	H1324	Left Primary not in neutral
D7556	Right reverse drive solenoid error OFF	H2005	Boost solenoid short to battery
D7557	Right front steer extend short to ground	H2006	Boost solenoid short to ground
D7558	Right front steer retract short to ground	H2007	Boost solenoid open circuit
D7559	Left front steer extend short to ground	H2032	Boost solenoid overcurrent
D7560	Left front steer retract short to ground	H2205	Pressure control solenoid short to battery
D7561	Right rear steer extend short to ground	H2206	Pressure control solenoid short to ground
D7562	Right rear steer retract short to ground	H2207	Pressure control solenoid open circuit
D7563	Left rear steer extend short to ground	H2232	Pressure control solenoid overcurrent
D7564	Left rear steer retract short to ground	H2305	Rear base solenoid short to battery
D7565	Steer pressure short to ground	H2306	Rear base solenoid short to ground
D7566	Back-up alarm error OFF	H2307	Rear base solenoid open circuit
D7567	No communication from Gateway controller	H2332	Rear base solenoid overcurrent
D7568	Angle sensors not calibrated	H2405	Rear rod solenoid short to battery
D7569	Battery voltage out of range high	H2406	Rear rod solenoid short to ground
D7570	Interrupted power	H2407	Rear rod solenoid open circuit
D7571	Battery voltage out of range low	H2432	Rear rod solenoid overcurrent

## SEAT BAR SENSOR (CONT'D)

### Removal And Installation

Remove the seat bar from the loader. (See Removal And Installation on Page 50-10-1.)

Figure 60-110-5

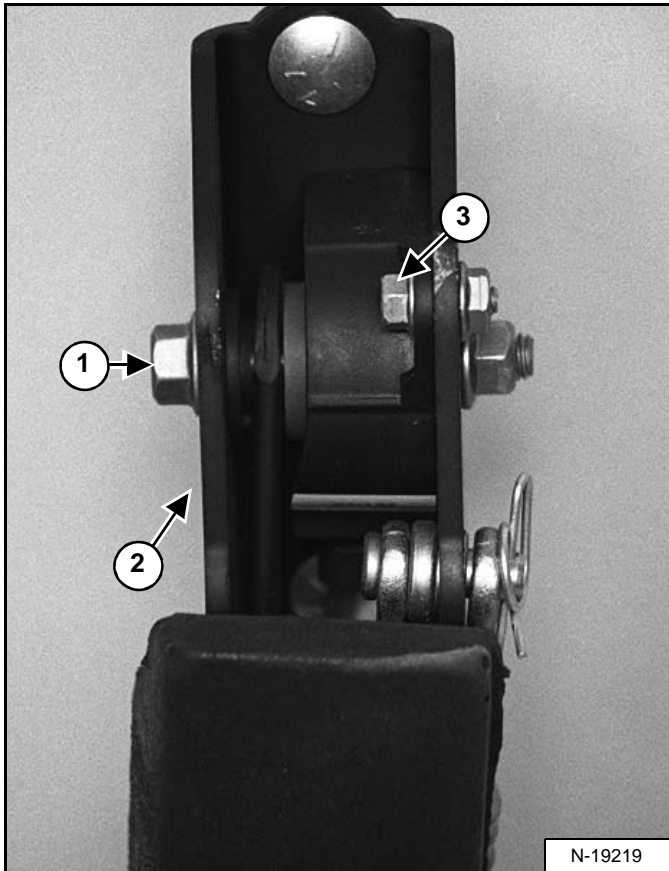

Remove the mounting bolt (Item 1) from the seat bar mount (Item 2) [Figure 60-110-5].

**Installation:** Tighten the mounting bolt to 5,6 - 7,9 N•m (50 - 70 in-lb) torque.

Remove the sensor mounting bolt (Item 3) [Figure 60-110-5] and nut.

Figure 60-110-6

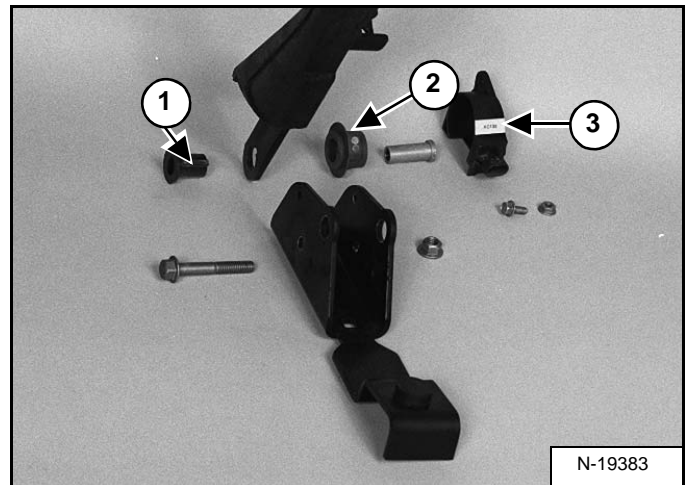

Remove the keyed plastic bushing (Item 1) magnetic bushing assembly (Item 2) and sensor bracket (Item 3) [Figure 60-110-6].

## IMPORTANT

Be careful to not overtighten the sensor mounting bolt and nut to prevent breakage of the sensor.

I-2088-1095

**Installation:** Be sure the tabs on the pivot bushing are positioned in the slotted hole (Item 1) [Figure 60-110-6] of the seat bar.

Inspect all parts for damage and wear and replace if necessary.

Reverse the removal procedure to install the seat bar sensor.

## CONTROL SYSTEM (ACS) (CONT'D)

### Handle Sensor Connector Disassembly And Assembly

Figure 60-130-1

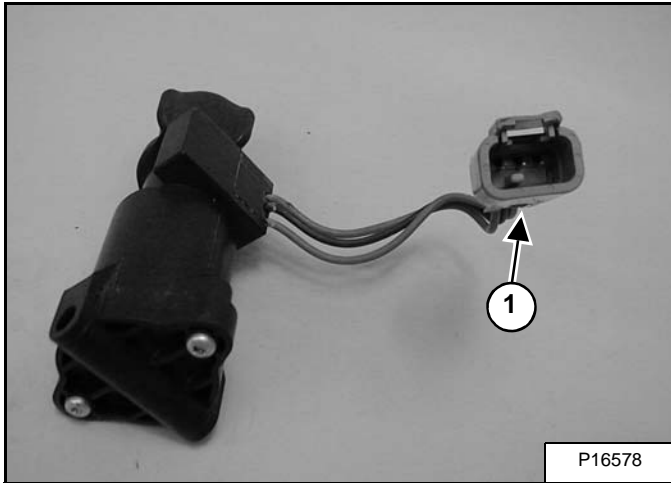

The wire connector (Item 1) [Figure 60-130-1] can be removed from the handle sensor wires, use the following procedure.

Figure 60-130-2

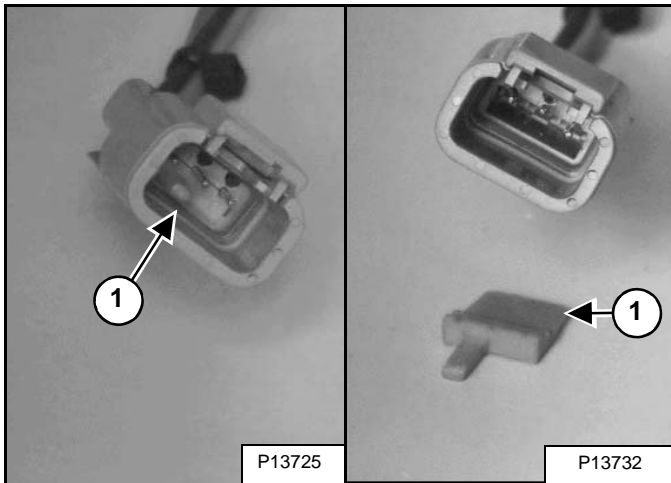

Remove the wedge (Item 1) [Figure 60-130-2] from the connector.

Figure 60-130-3

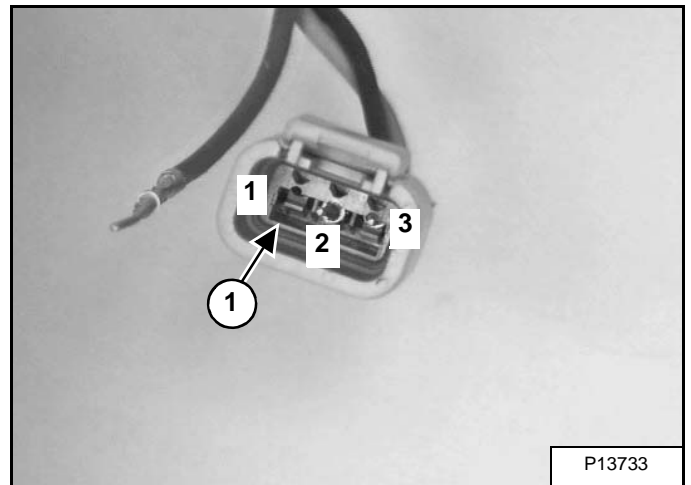

With a pointed tool, lift the tab (Item 1) [Figure 60-130-3] and pull the wire from the connector.

**Installation:** Install the wires into the connector as listed below [Figure 60-130-3]:

- 1-Terminal - Red
- 2-Terminal - Black
- 3-Terminal - Green

# ELECTRICAL / HYDRAULIC CONTROLS

## Identification Chart

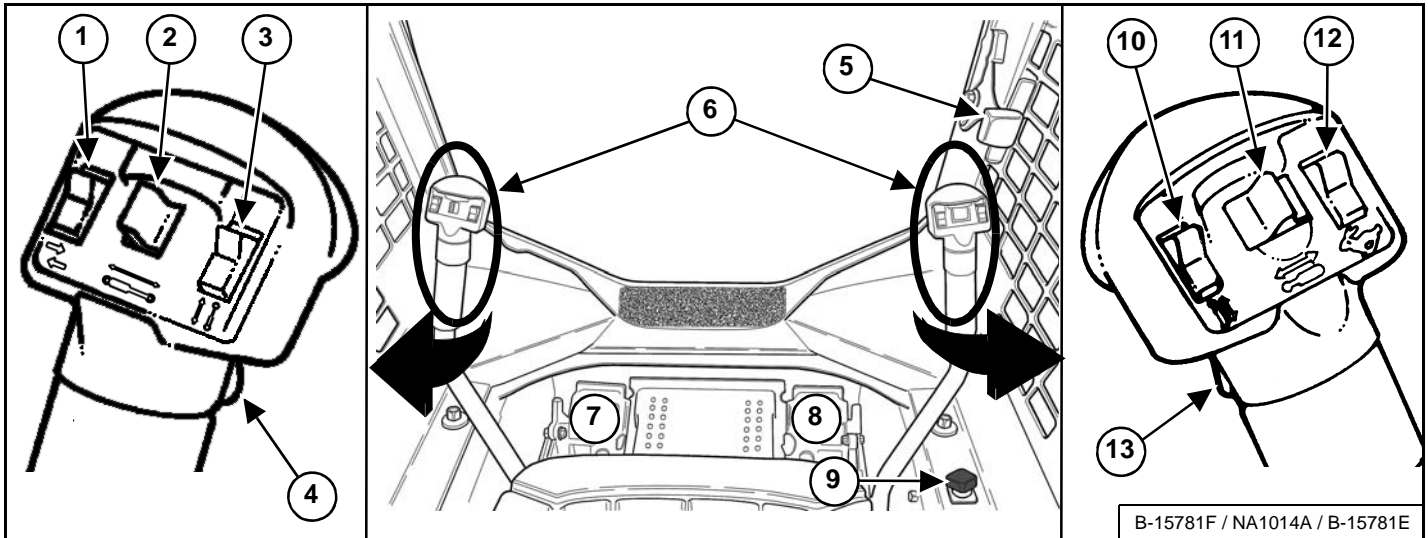

REF. NO.	DESCRIPTION
1	TURN SIGNALS (Option)
2	REAR AUXILIARY HYDRAULICS (Option) Also: ATTACHMENT FUNCTION CONTROL
3	ATTACHMENT FUNCTION CONTROL
4	FRONT HORN
5	ENGINE SPEED CONTROL
6	STEERING LEVERS
7	LIFT ARM PEDAL
8	TILT PEDAL
9	LIFT ARM BYPASS CONTROL
10	ATTACHMENT FUNCTION CONTROL
11	FRONT AUXILIARY HYDRAULICS
12	NOT USED
13	CONTINUOUS FLOW CONTROL FOR AUXILIARY HYDRAULICS

**ELECTRICAL / HYDRAULIC CONTROLS (ACS) (CONT'D)**

**Identification Chart ACD Group 2**

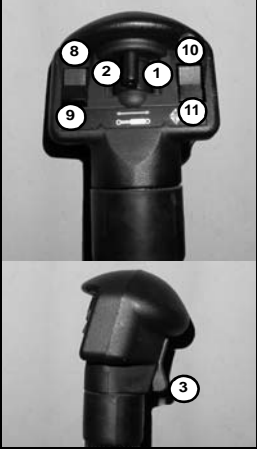
Left side Control Handle Switches	Switch Number	Solenoid Number Activated				Attachment Harness Terminal Activated	Attachment Harness Connector	Right Side Control Handle Switches
		STD	RH	HFH	RH / HFH			
 P-90898 P-90900	1	1	1	1, 7	1, 7	K	 P-90899 P-90900A	
	2	2	2	2	2	K		
	3	1	1	1, 7	1, 7	K		
	4	2	2	2	2	K,A		
	5	1	1	1, 7	1, 7	K,A		
	6	-	-	-	-	K,E		
	7	-	-	-	-	K,F		
	8	-	-	-	-	K,G		
	9	-	-	-	-	K,H		
	10, 11, 12, 13, 14	-	--	--		K		

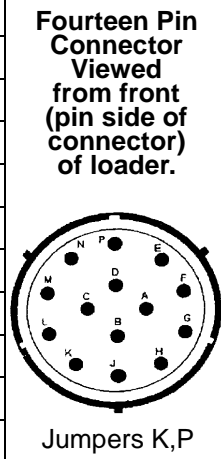

**RH - Loaders with Rear Hydraulics Option.**  
**HFH - Loaders with High Flow Hydraulics Option.**  
**RH / HFH - Loaders with Rear Hydraulics and High Flow Hydraulics Option.**  
**Terminal K is activated with Key switch ON.**

**NOTE:** For diagnostics and troubleshooting connect the Service PC (See SERVICE PC (LAPTOP COMPUTER) on Page 60-150-1.)

The ACD (Attachment Control Device) automatically recognizes the use of the seven or fourteen pin connector when connected.

Pressing the auxiliary hydraulics button and moving the rear auxiliary hydraulic switch to the right and left several times activates solenoid numbers 3,4,5, and 6 at the diverter valve.

Front Auxiliary Pressure Release is accomplished by manually pushing the male and female couplers in at the front auxiliary block.

The High Flow Button in the left side instrument panel must be pushed ON to activate solenoid number seven at the gear pump.

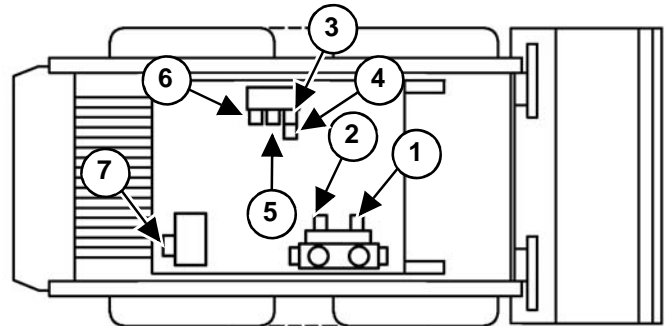

NA1892

Solenoid Number	Hydraulic Coupler	Wiring Number
1	Front Male (Rod)	4330
2	Front Female (Base)	4340
3	Diverter Rear (Rod)	4430
4	Diverter Rear (Base)	4440
5	Bleed / Lock Valve (Base)	4480
6	Bleed / Lock Valve (Rod)	4450
7	High Flow on Pump	4460

## CALIBRATION

### Description

Calibration procedures must be followed when replacing a hydraulic control valve, actuator, Drive / Drive+ Controller, ACS Controller, pump controller, hydrostatic pump, or hydrostatic motor. Failure to calibrate after component replacement may result in poor performance or reduced life of actuator(s).

The Actuator Test is performed with the Service PC. The Actuator Test should be used if reduced performance codes are present or when replacing a controller or actuator.

**NOTE: The Actuator Test should be used as the preferred method of actuator and valve spool calibration.**

The Lift and Tilt Calibration (ACS) provides set points to the ACS controller to actuate the lift and tilt valve. The Lift and Tilt Calibration (ACS) should be used if reduced performance codes are present or when replacing a controller or actuator.

The Lift and Tilt Calibration (SJC) provides set points to the ACS controller to actuate the lift and tilt valve. The Lift and Tilt Calibration (SJC) should be used if reduced performance codes are present or when replacing a controller or actuator.

The Hydrostatic Pump Calibration (SJC) provides set points to the Drive controller to actuate the hydrostatic controller that directs flow to a servo piston. Hydrostatic Pump Calibration (SJC) should be performed when a desired travel path cannot be attained or replacing the hydrostatic pump, hydrostatic motor, or controller. After Performing a Hydrostatic Pump Calibration (SJC), Steering Drift Compensation can be used to fine tune the hydrostatic pump control.

For more information on Steering Drift Compensation (See STEERING DRIFT COMPENSATION on Page 60-161-1.)

**NOTE: The Actuator Test is the only test that uses a Service PC. The Lift and Tilt Calibration (ACS or SJC) does not need to be performed if the Actuator Testing is being performed with the Service PC. The Hydrostatic Pump Calibration does not need to be performed with the Actuator Test or Lift and Tilt Calibration (SJC).**

## Actuator Testing

Figure 60-160-1

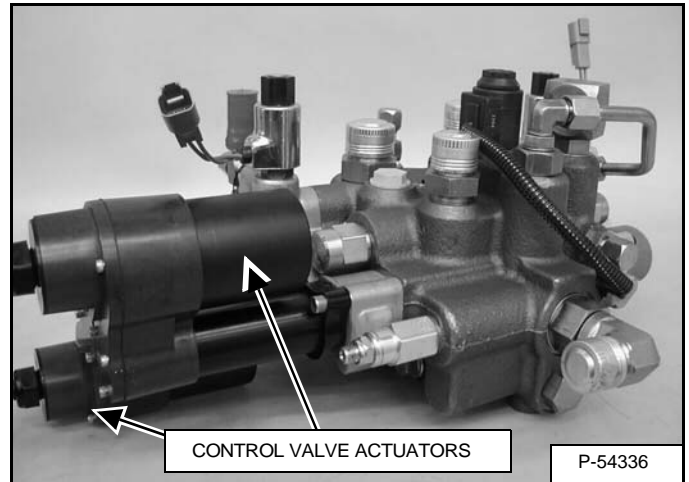

**[Figure 60-160-1]** Excessive actuator loading can occur if the actuator and valve spool components are misaligned. Misalignment may reduce spool stroke performance and reduce the life of the actuator. Starting with software version 36, the Bobcat Service Analyzer will be able to perform tests to diagnose actuator and valve spool misalignment.

Connect the Service PC. (See SERVICE PC (LAPTOP COMPUTER) on Page 60-150-1.)

If a Service PC is not available, (See Lift And Tilt Calibration (SJC) on Page 60-160-4.) or (See Lift And Tilt Calibration (ACS) on Page 60-160-11.).

**NOTE: Warm the hydraulic oil to room temperature 22°C (72°F), stop the engine and clear all active service codes before running the test.**

Once the test is initiated, an automatic calibration sequence will start. When calibration is complete, the test will be performed and the results can be viewed on the Service PC (Laptop) monitor.

## CALIBRATION (CONT'D)

### Lift And Tilt Calibration (ACS)

The controller uses a calibration sequence to optimize the control system. The optimizing ensures full spool stroke (full flow) while preventing over stroke (loading) of the actuator and resets the calibration points in the controller.

**NOTE:** The Actuator Test is the preferred method to calibrate the lift and tilt actuator. (See Actuator Testing on Page 60-160-1.)

**NOTE:** This calibration procedure must be followed when replacing a hydraulic control valve, actuator or ACS controller. Failure to calibrate after component replacement may result in poor performance or reduced life of actuator(s).

Figure 60-160-23

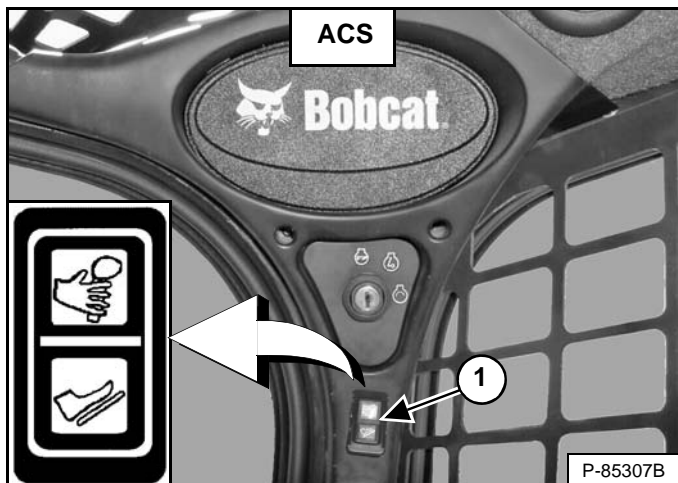

Update the loader service software to the latest version.

Place the rocker switch (Item 1) [Figure 60-160-23] in the hand control mode.

Figure 60-160-24



Close the cab door. (If loader is equipped.)

With the seat bar down, turn the ignition key ON (Deluxe Instrumentation Panel press RUN / ENTER) (Item 1) [Figure 60-160-24].

**NOTE:** Do not start the engine.

Figure 60-160-25



Push the PRESS TO OPERATE button (Item 1) [Figure 60-160-25] to unlock the hand controls.

## PASSWORD SETUP (KEYLESS START PANEL)

### Password Description

#### Master Password:

A permanent, randomly selected password set at the factory which cannot be changed. This password is used for service by the Bobcat dealer if the owner password is not known; or to change the owner password.

#### Owner Password:

Allows for full use of the loader. It must be used to change the owner password.

### Changing The Owner Password

Press the RUN button to turn on the loaders electrical system.

Enter the five digit owner password using the number keys (1 through 0) if locked.

Figure 60-191-1



Press and hold the lock (Item 1) and unlock (Item 2) [Figure 60-191-1] keys for two seconds.

The lock key red light will flash and the left panel display screen will show [ENTER].

Enter a new five digit password using the number keys (1 through 0). An asterisk will show in the left panel display screen for each key press.

The left panel display screen will show [AGAIN].

Enter the new five digit password again.

The lock key red light will become solid.

### Password Lockout Feature

This feature allows the owner to unlock the password feature so that a password does not need to be used every time the engine is started.

Press the RUN button to turn on the loaders electrical system.

Enter the five digit owner password using the number keys (1 through 0).

Figure 60-191-2

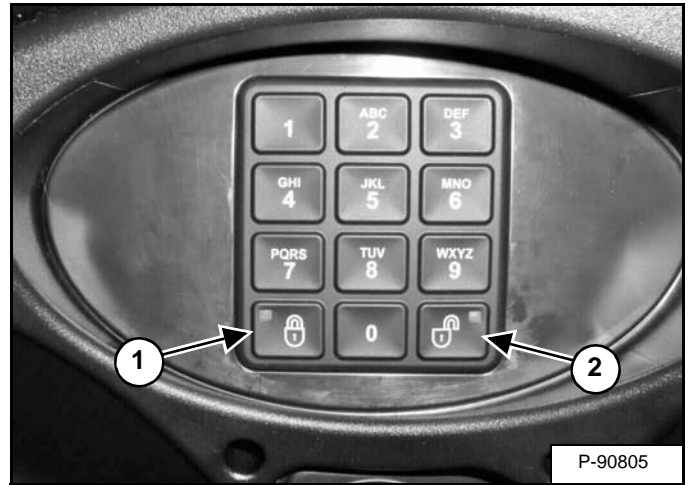

Press the unlock key (Item 2) [Figure 60-191-2].

The left panel display screen will show [CODE].

Enter the five digit owner password using the number keys (1 through 0). The unlock key green light will flash, then become solid.

The loader can now be started without using a password.

**NOTE: Use the following procedure to reset the machine lock so that the loader requires a password to start the engine.**

Press the RUN button to turn on the loaders electrical system.

Press the lock key (Item 1) [Figure 60-191-2].

The lock key red light will flash and the left panel display screen will show [CODE].

Enter the five digit owner password using the number keys (1 through 0). The unlock key green light will flash, then the lock key red light will become solid.

You must now enter the password every time to start the loader.

## BACK-UP ALARM SYSTEM (CONT'D)

### Troubleshooting (Standard And ACS)

The following troubleshooting chart is provided for assistance in locating and correcting problems which are most common. Many of the recommended procedures must be done by authorized Bobcat Service Personnel only.



# WARNING

#### AVOID INJURY OR DEATH

Instructions are necessary before operating or servicing machine. Read and understand the Operation & Maintenance Manual, Operator's Handbook and signs (decals) on machine. Follow warnings and instructions in the manuals when making repairs, adjustments or servicing. Check for correct function after adjustments, repairs or service. Untrained operators and failure to follow instructions can cause injury or death.

W-2003-0807

PROBLEM	CAUSE
Back-up alarm will not sound when the operator moves both steering levers into the reverse position.	1, 2, 3, 4, 5, 6, 7
Back-up alarm sounds when steering levers in neutral / forward position.	2, 6, 7

#### KEY TO CORRECT THE CAUSE

1. The ground connection is not making a good contact.
2. The back-up alarm switches are damaged.
3. The alarm is damaged.
4. The back-up alarm or switch wires are disconnected.
5. Check the fuses.
6. The wiring is damaged.
7. The back-up alarm switches need adjusting.

## ENGINE INFORMATION

### Description

The S650 has a Kubota direct injected V3307-DI-T turbo diesel engine with a displacement of 3,3 L (203 in<sup>3</sup>). The engine is rated at an SAE Gross 55,4 kW (74.3 hp) and has a closed breather system [Figure 70-10-1].

The engine has 4 cylinders and the rotation is counter-clockwise (viewed from the flywheel side). It is equipped with glow plugs for assisting in cold starts. Engine block heaters are also available from Bobcat Parts.

To meet emission regulations it is also equipped with an Exhaust Gas Recirculation (EGR) system to reduce Nitrogen Oxide (NOx).

The engine serial number is stamped on the engine and is located near the injection pump. The model number is located on the valve cover. Use these numbers to obtain the correct service parts.

The engine is liquid cooled with a propylene glycol/water mixture in a radiator. Coolant flow is controlled by a thermostat. The cooling fan is driven by a hydraulic motor. The speed of the fan is determined by the engine coolant temperature sensor and the hydraulic/hydrostatic fluid temperature sensor.

**Figure 70-10-1**

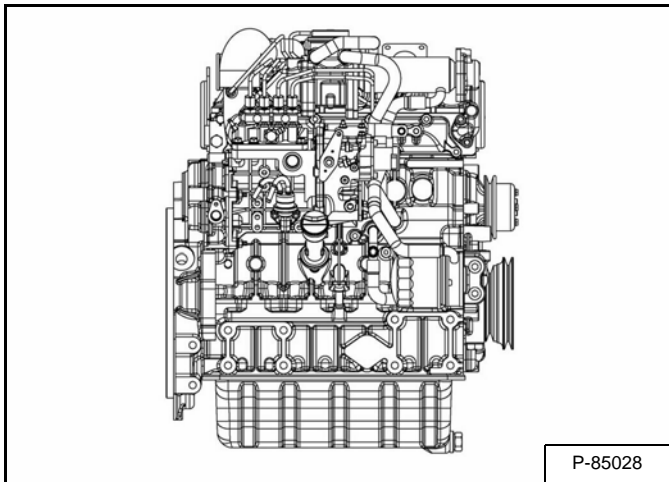

## ENGINE INFORMATION (CONT'D)

### Engine Removal And Installation (Cont'd)

Figure 70-10-16

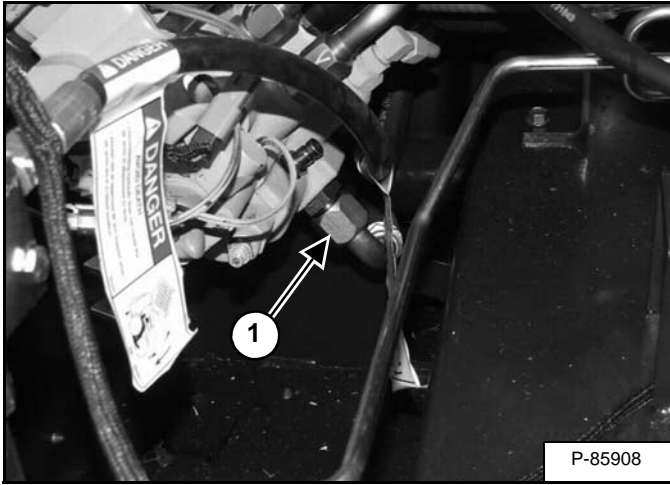

Disconnect hydraulic control valve inlet hose (Item 1) [Figure 70-10-16].

Cap or plug all hoses and fittings.

Figure 70-10-17

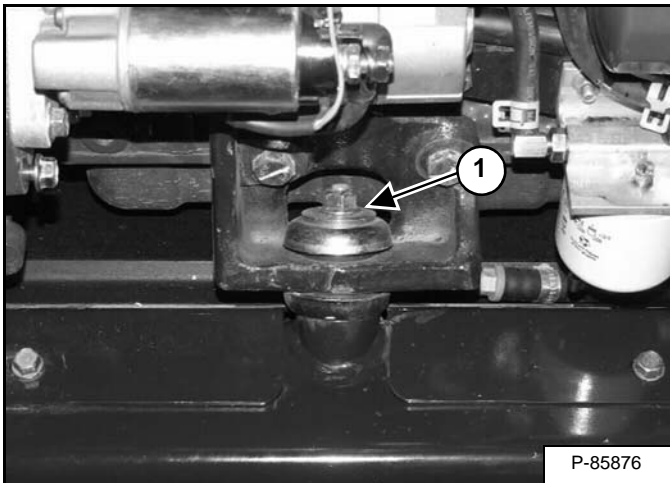

Remove rear engine mounting bolt (Item 1) [Figure 70-10-17].

**Installation:** Tighten the mounting bolt to 135 N•m (100 ft-lb) torque.

Figure 70-10-18

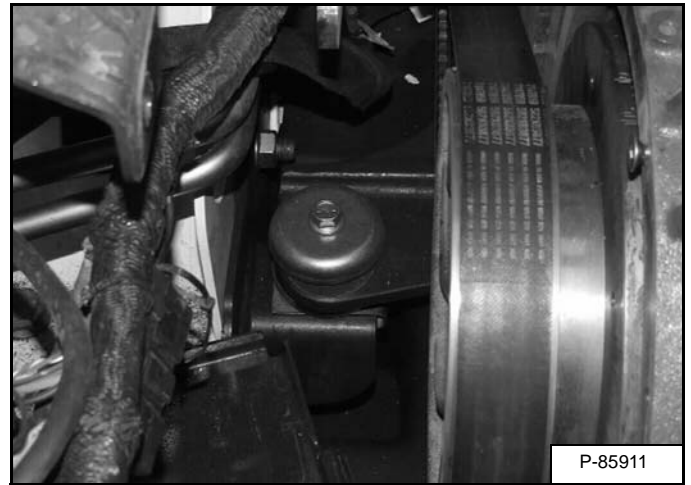

Remove the mounting bolt (Item 1) [Figure 70-10-18] from the left engine mount.

**Installation:** Tighten the mounting bolt (Item 1) [Figure 70-10-18] to 135 N•m (100 ft-lb) torque.

Figure 70-10-19

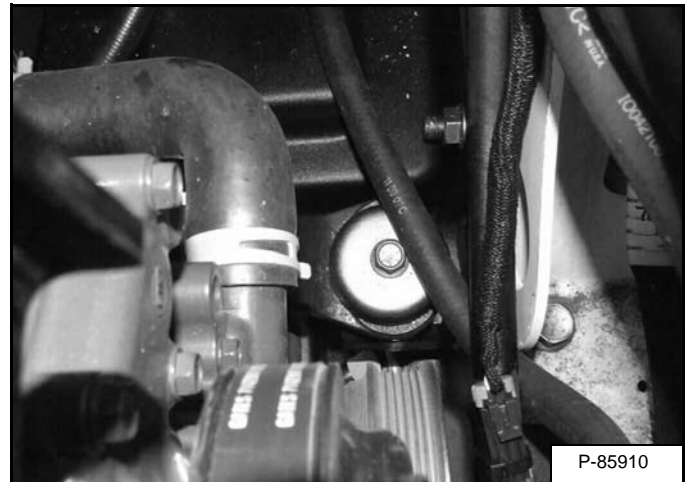

Remove the mounting bolt (Item 1) [Figure 70-10-19] from the right engine mount.

**Installation:** Tighten the mounting bolt to 135 N•m (100 ft-lb) torque.

**ENGINE SPEED CONTROL (SJC) S/N A3NV12469 AND BELOW & S/N A3NW11130 AND BELOW (CONT'D)**

**Disassembly And Assembly (Cont'd)**

**Figure 70-21-9**

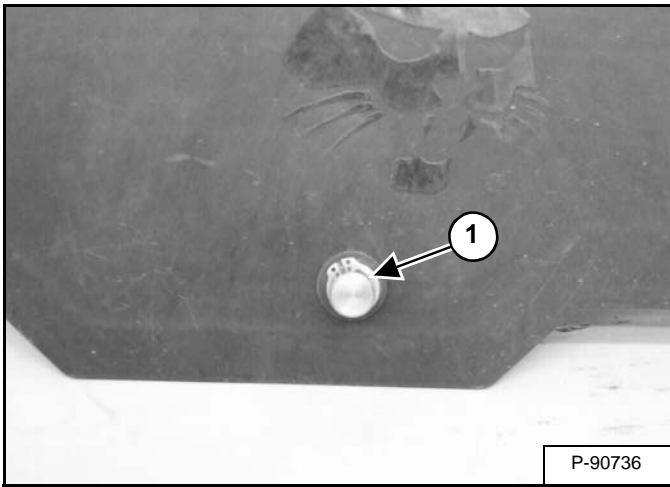

Remove the snap ring (Item 1) [Figure 70-21-9] from the engine speed control foot pedal pivot.

**Figure 70-21-10**

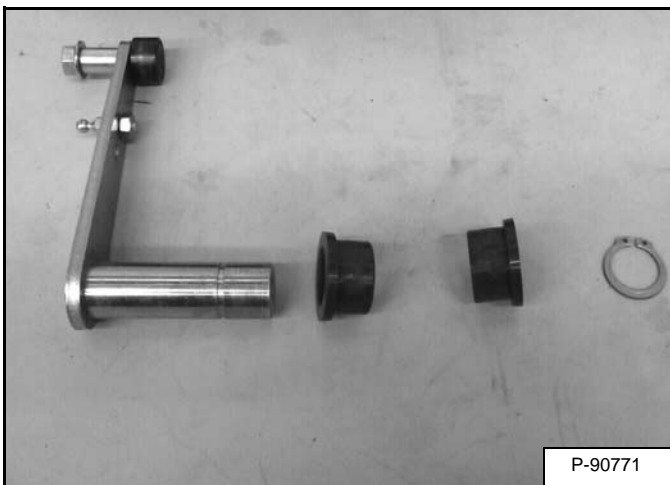

The engine speed control foot pedal pivot assembly shown disassembled, [Figure 70-21-10] replace worn parts as needed.

**NOTE: No lubrication is necessary or recommended on the engine speed control.**

**Figure 70-21-11**

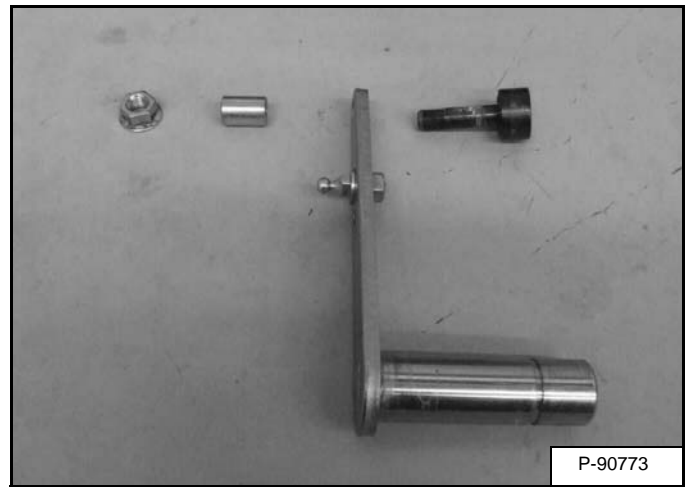

The engine speed control foot pedal pivot assembly roller bearing [Figure 70-21-11] shown disassembled.

## ENGINE COOLING SYSTEM

### Radiator Removal And Installation

Stop the engine and open the rear door.

Remove the rear grille and side panels. (See Removal And Installation on Page 50-60-1.)

Remove the oil cooler. (See Removal And Installation on Page 20-90-1.)

**! WARNING**

#### AVOID BURNS

Do not remove radiator cap when the engine is hot. You can be seriously burned.

W-2070-1203

Figure 70-50-1

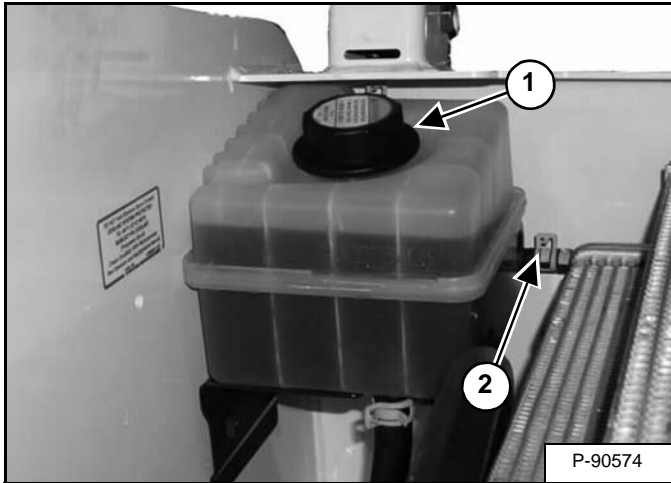

Loosen the radiator cap (Item 1) from the pressurized expansion tank. Disconnect and plug radiator air bleed hose (Item 2) [Figure 70-50-1].

Figure 70-50-2

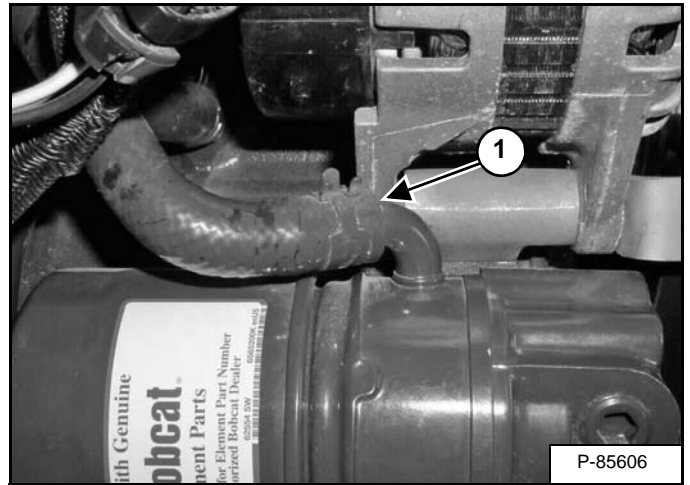

Remove hose (Item 1) [Figure 70-50-2] on the engine oil cooler and drain the coolant into a container.

Figure 70-50-3

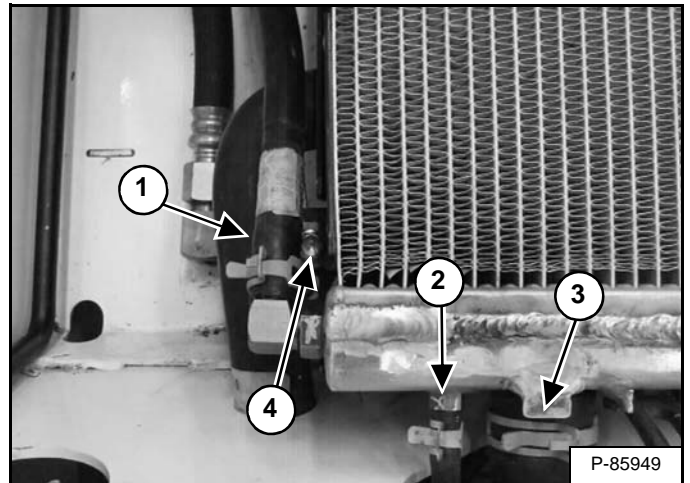

Disconnect the pressurized expansion tank fill hose (Item 1), disconnect the coolant air bleed hose (Item 2) and the radiator hose (Item 3) [Figure 70-50-3].

Remove the radiator hold down bolt (Item 4) [Figure 70-50-3].

## LUBRICATION SYSTEM

### Oil Pan Removal And Installation

Remove the engine and hydrostatic pump assembly from the loader. (See Engine Removal And Installation on Page 70-10-7.)

The engine will have to be on an engine stand or suspended in the air safely to remove the oil pan.

Figure 70-60-1

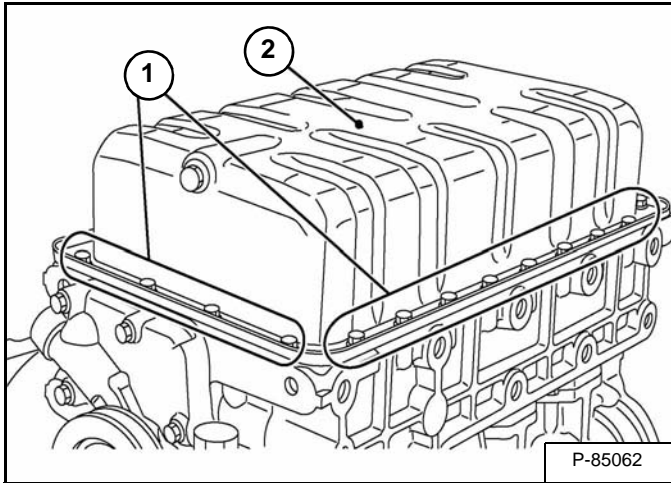

Remove oil pan bolts (Item 1) securing oil pan (Item 2) [Figure 70-60-2]. Slightly tapping on the oil pan with a soft mallet will break loose the oil pan from the engine block.

**Installation:** Use a liquid gasket adhesive to the oil pan side of the oil pan gasket. Tighten oil pan bolts to 39 - 75 N•m (29 - 33 ft-lb) torque.

Figure 70-60-2

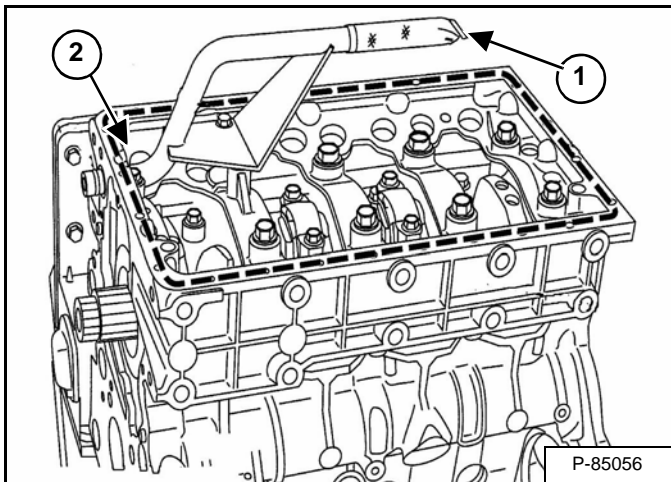

Remove the oil strainer (Item 1) and O-ring (Item 2) [Figure 70-60-2] from the engine block.

**Installation:** Apply oil to O-ring.

### Oil Pump Removal And Installation

Figure 70-60-3

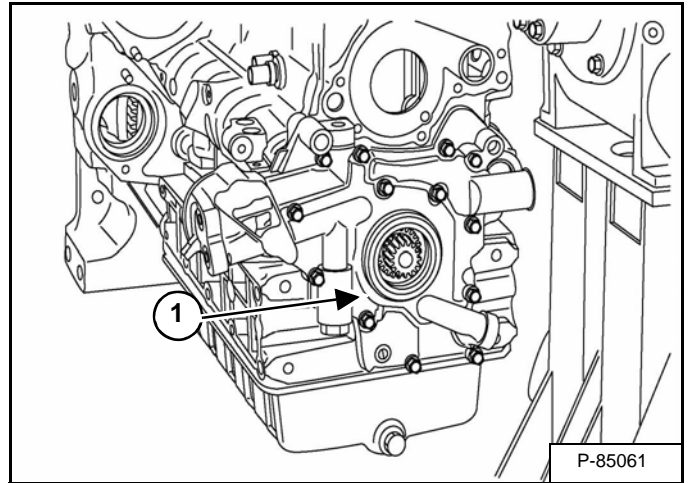

Remove the bolts from the front cover / oil pump (Item 1) [Figure 70-60-3].

**Installation:** Use a liquid gasket adhesive. Tighten the front cover / oil pump mounting bolts to 24 - 27 N•m (18 - 20 ft-lb) torque.

## FUEL SYSTEM (CONT'D)

### Governor Housing Disassembly And Assembly (Cont'd)

Figure 70-70-18

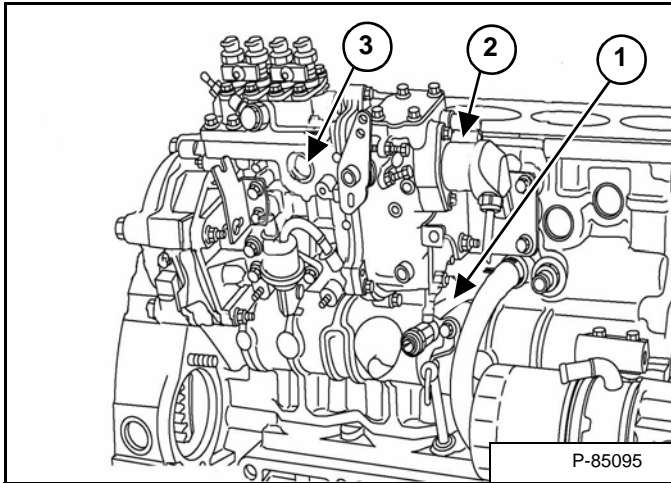

Remove the fuel injection pump assembly. (See Fuel Injection Pump Assembly Removal And Installation on Page 70-70-3.)

Remove the governor lubricating pipe (Item 1) [Figure 70-70-18].

Remove the stop solenoid (Item 2) [Figure 70-70-18].

Remove the sight cover (Item 3) [Figure 70-70-18] from the injection pump unit.

Figure 70-70-19

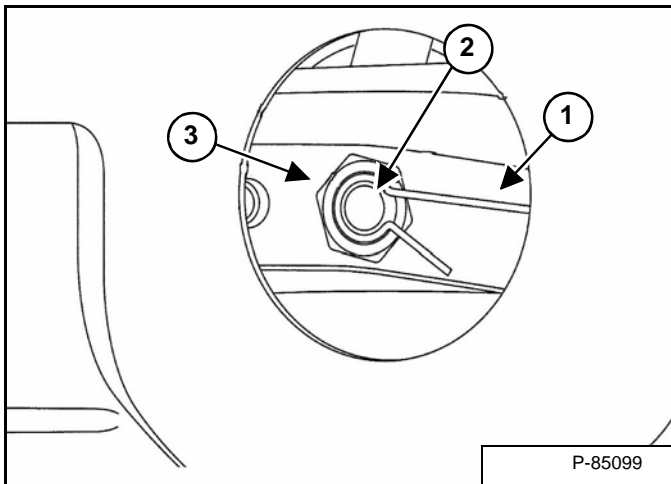

Unhook the start spring (Item 1) from the rack pin (Item 2) [Figure 70-70-19] of injection pump assembly.

Remove the nut (Item 3) [Figure 70-70-19].

**Installation:** Reverse procedure to install. Tighten the nut to 2.9 - 4,0 N•m (2.1 - 2.9 ft-lb) torque.

**NOTE:** Be careful not to drop the nut inside.

**NOTE:** (See Fuel Injection Pump Removal And Installation on Page 70-70-12.) for proper alignment of the governor connection rod procedure. The procedure will require a special tool as shown on page 70-70-6.

Figure 70-70-20

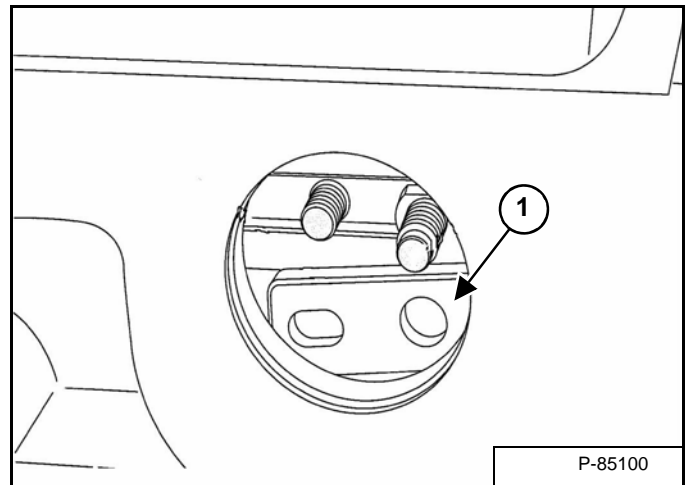

Slide off the governor connecting rod (Item 1) [Figure 70-70-19] from the rack pin of injection pump assembly.

For convenient sake, temporarily hook the start spring on the rack pin hole of the governor connecting rod.

Remove the governor housing mounting bolts.

**Installation:** Tighten the governor housing bolts to 9,81 - 11,2 N•m (7.24 - 8.31 ft-lb) torque.

Figure 70-70-21

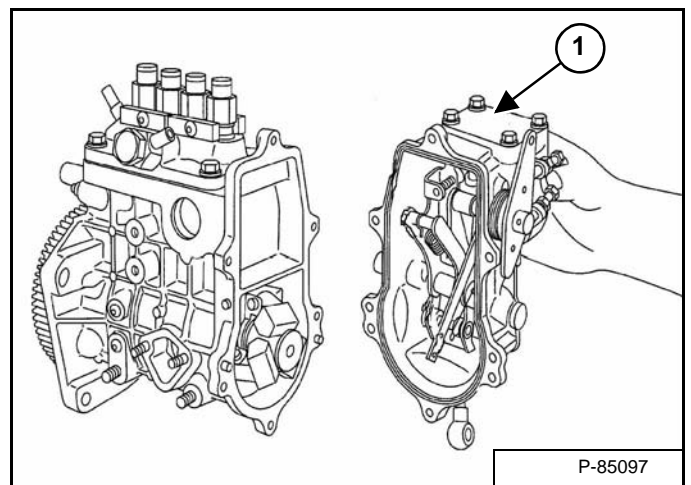

Remove the governor housing assembly (Item 1) [Figure 70-70-21] from the injection pump unit.

**NOTE:** The injection pump unit is lubricated with engine oil. Oil will leak when the governor housing is removed from the injection pump.

## FUEL SYSTEM (CONT'D)

### Fuel Injector Removal And Installation (Cont'd)

Figure 70-70-47

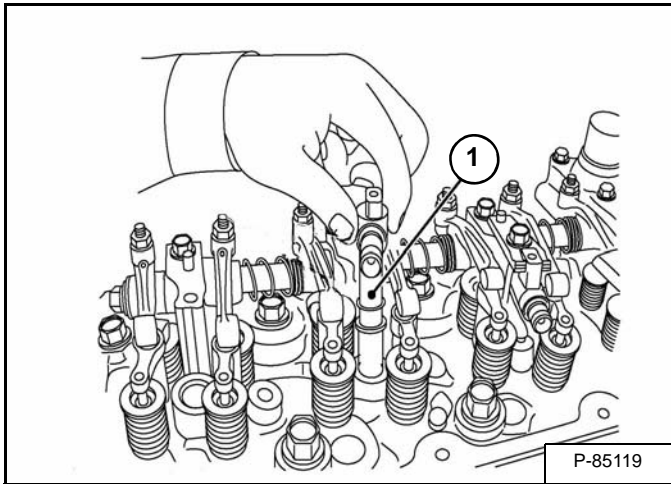

Remove the injector nozzle (Item 1) [Figure 70-70-47] from the cylinder head.

Pull on the injector nozzle to remove the injector nozzle from the cylinder head.

Figure 70-70-48

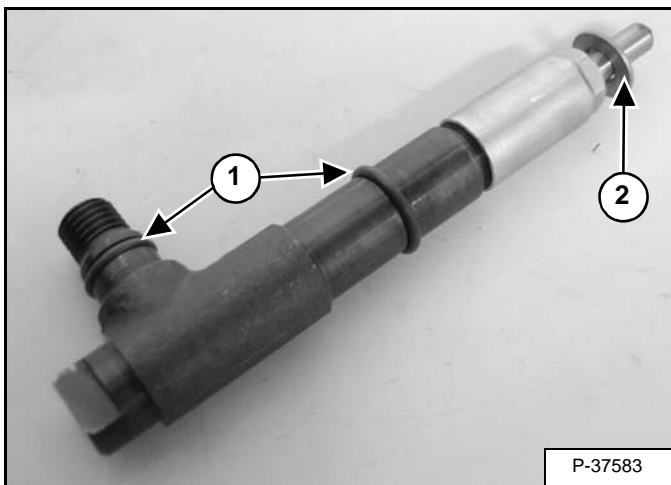

[Figure 70-70-48] shows the injector nozzle removed from the cylinder. Inspect the injector and replace if necessary.

Check and replace the injector nozzle O-rings (Item 1) and the nozzle washer (Item 2) before installing new or used injectors. [Figure 70-70-48].

### Fuel Injector Nozzle Pressure - Checking

The tool listed will be needed to do the following procedure:

OEM1064 - Injector Nozzle Tester

Figure 70-70-49

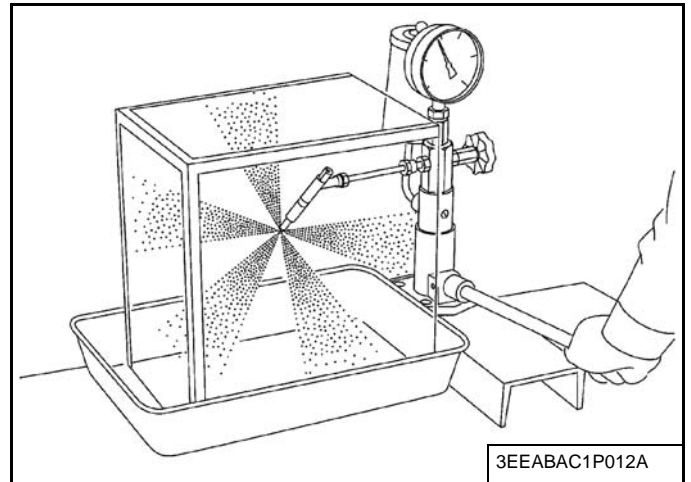

Set the injection nozzle to the nozzle tester.

Slowly move the tester handle to measure the pressure at which fuel begins jetting out from the nozzle.

If the measurement is not within the factory specifications, replace or repair the injection nozzle assembly.

**NOTE: Injection nozzle gasket must be replaced when the injection nozzle is removed for checking.**

Injection pressure	Factory spec.	18,6 -19,6 MPa (186,4 - 96 bar) (2703 - 2844 psi)

## CYLINDER HEAD (CONT'D)

### Valve Guide Removal And Installation

Figure 70-80-30

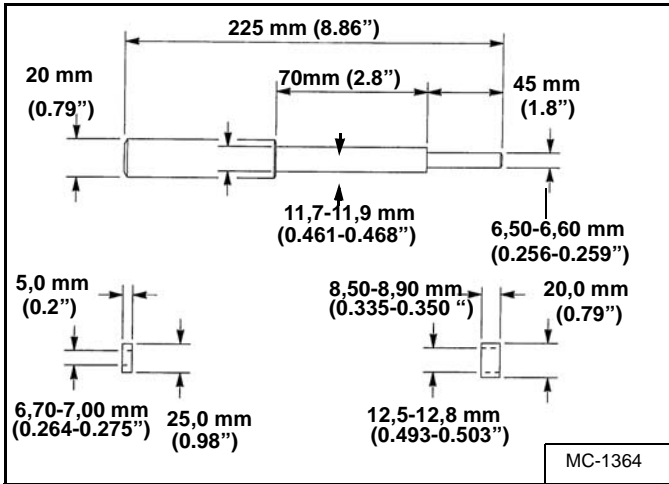

To remove and replace the valve guide, make the driver tools as shown in figure [Figure 70-80-30].

Figure 70-80-31

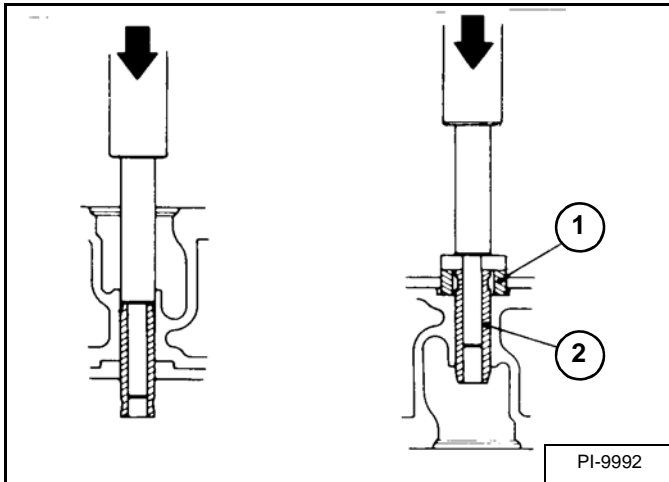

Press the used valve guide out of the cylinder head using the special driver tool [Figure 70-80-31].

Put oil on the outside diameter of the new valve guide. Press the new valve guide into the cylinder head from the top side. Use the special driver tools (Items 1 and 2) [Figure 70-80-31], press the new guide until the tool contacts the cylinder head.

Ream the valve guide to the correct specifications.

## Reconditioning The Valve And Valve Seat

Figure 70-80-32

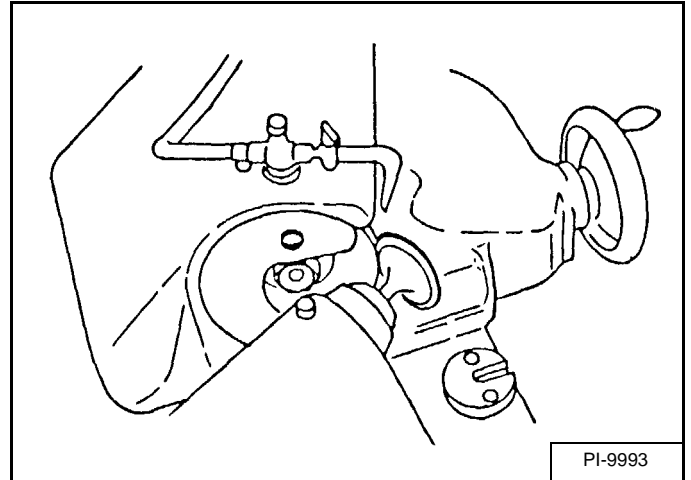

Grind the valve face to the correct angle using a valve refacer [Figure 70-80-32].

Clean the valve seat and combustion chamber.

Figure 70-80-33

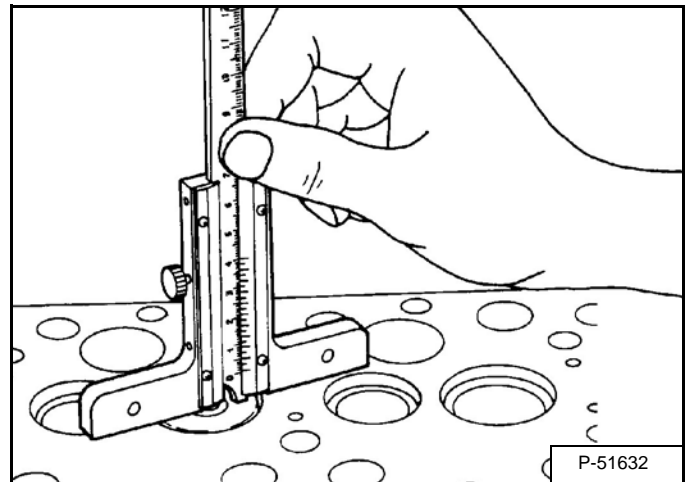

Install the valve into the guide. Measure the valve recessing with a depth gauge [Figure 70-80-33].

## CRANKSHAFT AND PISTONS (CONT'D)

### Piston And Connecting Rod - Servicing (Cont'd)

Figure 70-90-7

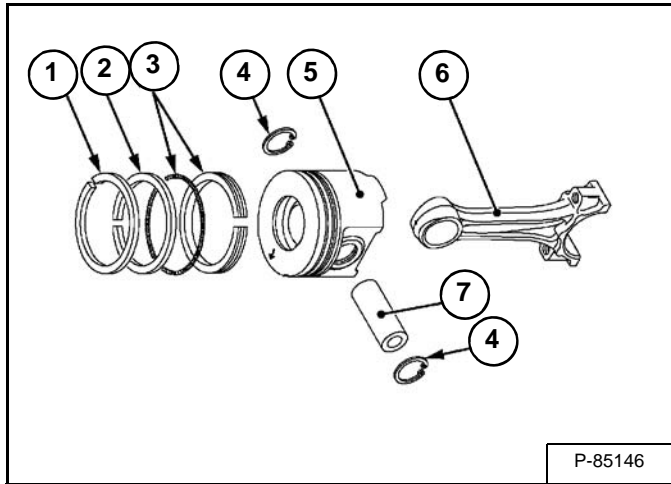

Remove the top ring (Item 1), the second ring (Item 2) and the oil ring (Item 3) [Figure 70-90-7].

Remove the snap rings (Item 4) and piston pin (Item 7) [Figure 70-90-7].

Separate the piston (Item 5) from the connecting rod (Item 6) [Figure 70-90-7].

**Installation:** Heat the piston in clean engine oil to 80°C (176°F) and tap the piston pin into position. Place the piston rings so that there are gaps every 120 degrees with no gap facing the piston pin in the cylinder.

**NOTE:** Mark the piston (Item 5) and connecting rod (Item 6) [Figure 70-90-7] with the same number to ensure correct installation and proper cylinder placement.

Figure 70-90-8

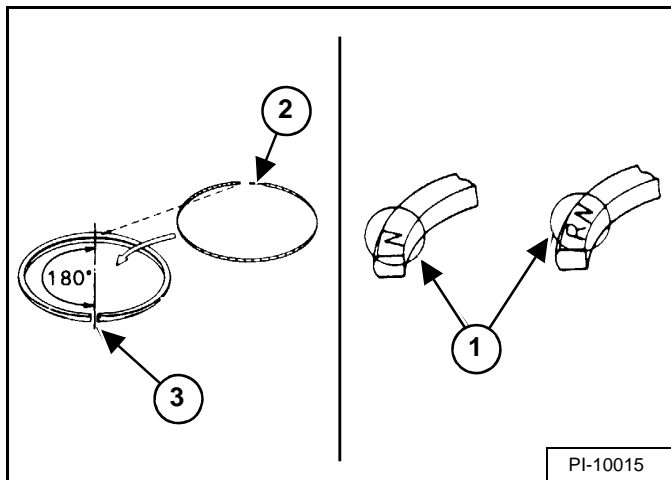

**Installation:** When installing new rings, assemble the ring so the mark (Item 1) near the gap faces the top of the piston. When installing the oil ring, place the expander joint (Item 2) on the opposite side of the oil ring gap (Item 3) [Figure 70-90-8].

Figure 70-90-9

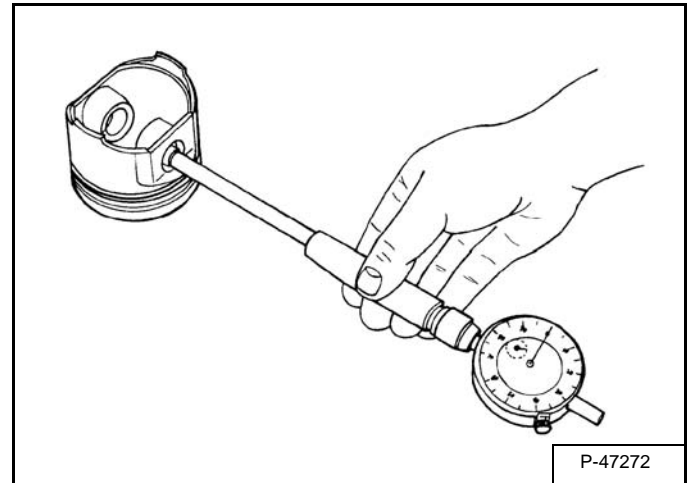

Measure the I.D. of the piston pin bore in both horizontal and vertical directions [Figure 70-90-9].

If the measurement exceeds the allowable limit, replace the piston.

Piston Bore I.D.	28,0 - 28,013 mm (1.1024 - 1.1028 in)
Allowable Limit	28,05 mm (1.104 in)

## CAMSHAFT AND TIMING GEARS

### Timing Gearcase Cover Removal

Remove the flywheel. (See Flywheel Removal And Installation on Page 70-120-1.)

Remove the housing. (See Housing Removal And Installation on Page 70-120-3.)

**Figure 70-100-1**

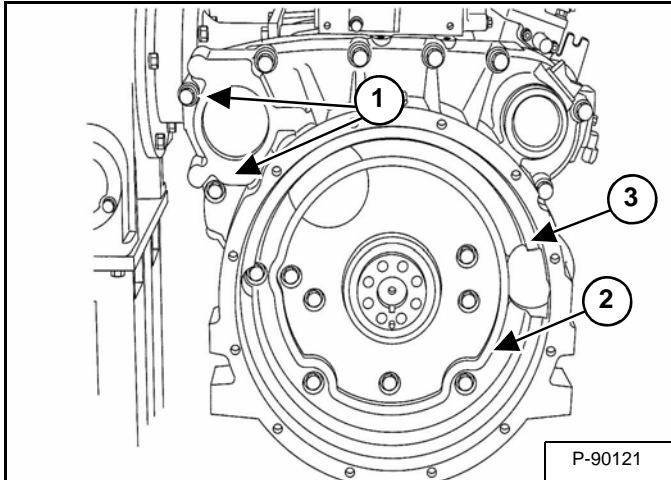

Remove the eight outside timing gearcase cover mounting bolts (Item 1) **[Figure 70-100-1]**.

Remove the eight inside timing gearcase cover mounting bolts (Item 2) **[Figure 70-100-1]**.

Remove the timing gearcase cover (Item 3) **[Figure 70-100-1]**.

## TURBOCHARGER (CONT'D)

### Removal And Installation (Cont'd)

Figure 70-110-6

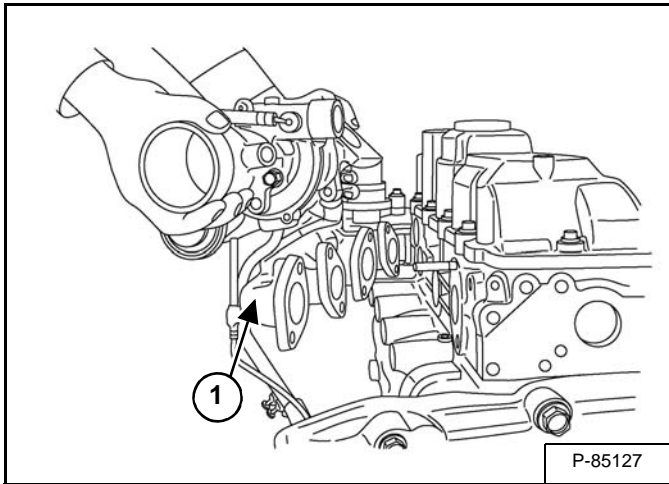

Remove the turbocharger assembly (Item 1) [Figure 70-110-6].

**Installation:** During installation replace all gaskets with new ones.

## EXHAUST GAS RECIRCULATION (EGR) SYSTEM (CONT'D)

### Removal And Installation

**! WARNING**

#### AVOID BURNS

Some surfaces of the Exhaust Gas Recirculation system can be hot. Use caution when conducting diagnostic tests.

Allow the engine to cool before servicing.

W-2716-0208

Allow the engine to cool before working on the EGR system.

Figure 70-130-10

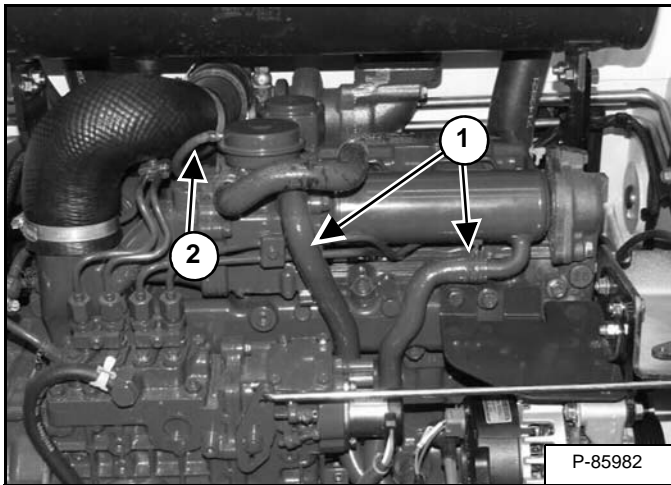

Disconnect and cap the EGR valve coolant hoses (Item 1) [Figure 70-130-10].

Disconnect the boost pressure hose (Item 2) [Figure 70-130-10].

Figure 70-130-11

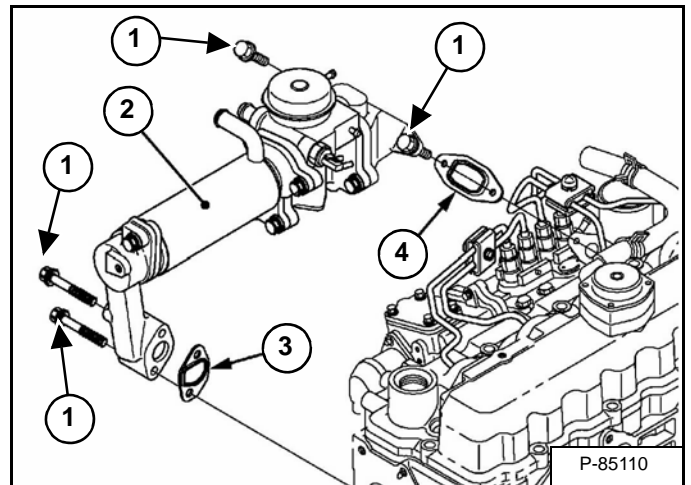

Remove the four EGR cooler mounting bolts (Item 1) and the EGR system assembly (Item 2) [Figure 70-130-11].

**Installation:** Replace the gaskets (Items 3 and 4) [Figure 70-130-11] with new ones.

Figure 70-130-12

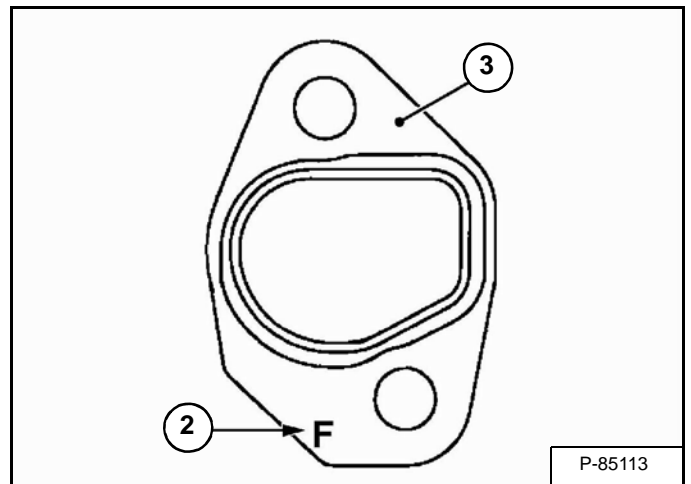

**NOTE:** The gasket (Item 3) [Figure 70-130-11] and [Figure 70-130-12] is marked with the letter "F" and must be installed downward.

## REGULAR MAINTENANCE

### Filters

#### Fresh Air Filters

Figure 80-20-1

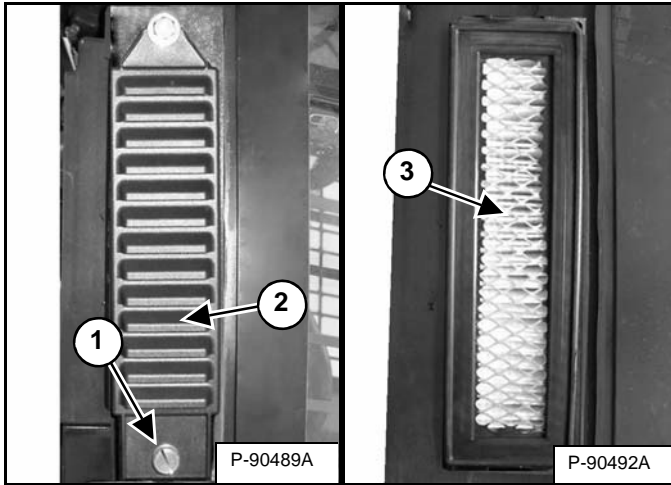

The fresh air filters are located behind the side windows outside the operators cab. (Right side shown) Remove the clamping knob (Item 1) and filter cover (Item 2) [Figure 80-20-1].

Shake the filter (Item 3) [Figure 80-20-1] or use low pressure air to remove dirt. This can be done several times before replacement is required. Install the filter, filter cover and clamping knob.

#### Recirculation Filter (Earlier Models)

Figure 80-20-2

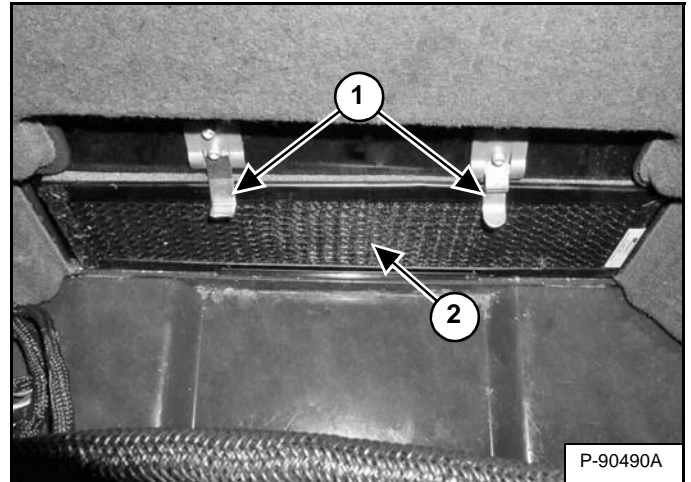

The recirculation filter is located behind the operators seat inside the operators cab. Flip the clamps (Item 1) holding the filter up and remove the filter (Item 2) [Figure 80-20-2].

Shake the filter or use a vacuum to clean. This can be done several times before replacement is required.

Install the filter into the opening and flip the clamps down to hold the filter in place.

#### Recirculation Filter (Later Models)

Figure 80-20-3

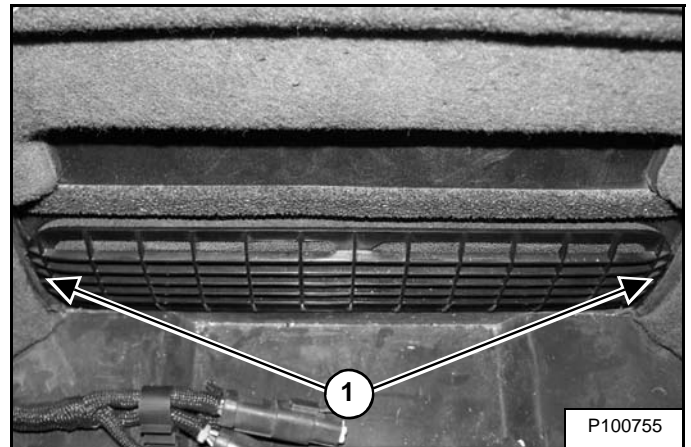

The recirculation filter is located behind the operator's seat inside the operator cab. The filter cover is held in place with three clips. Pull the cover at each end (Item 1) [Figure 80-20-3] to remove.

Rinse the filter elements with water or use a vacuum to clean. Do not use solvents.

Line up the clips on the filter cover with the slots provided and push the cover into place.

# TROUBLESHOOTING (CONT'D)

## Troubleshooting Tree (Cont'd)

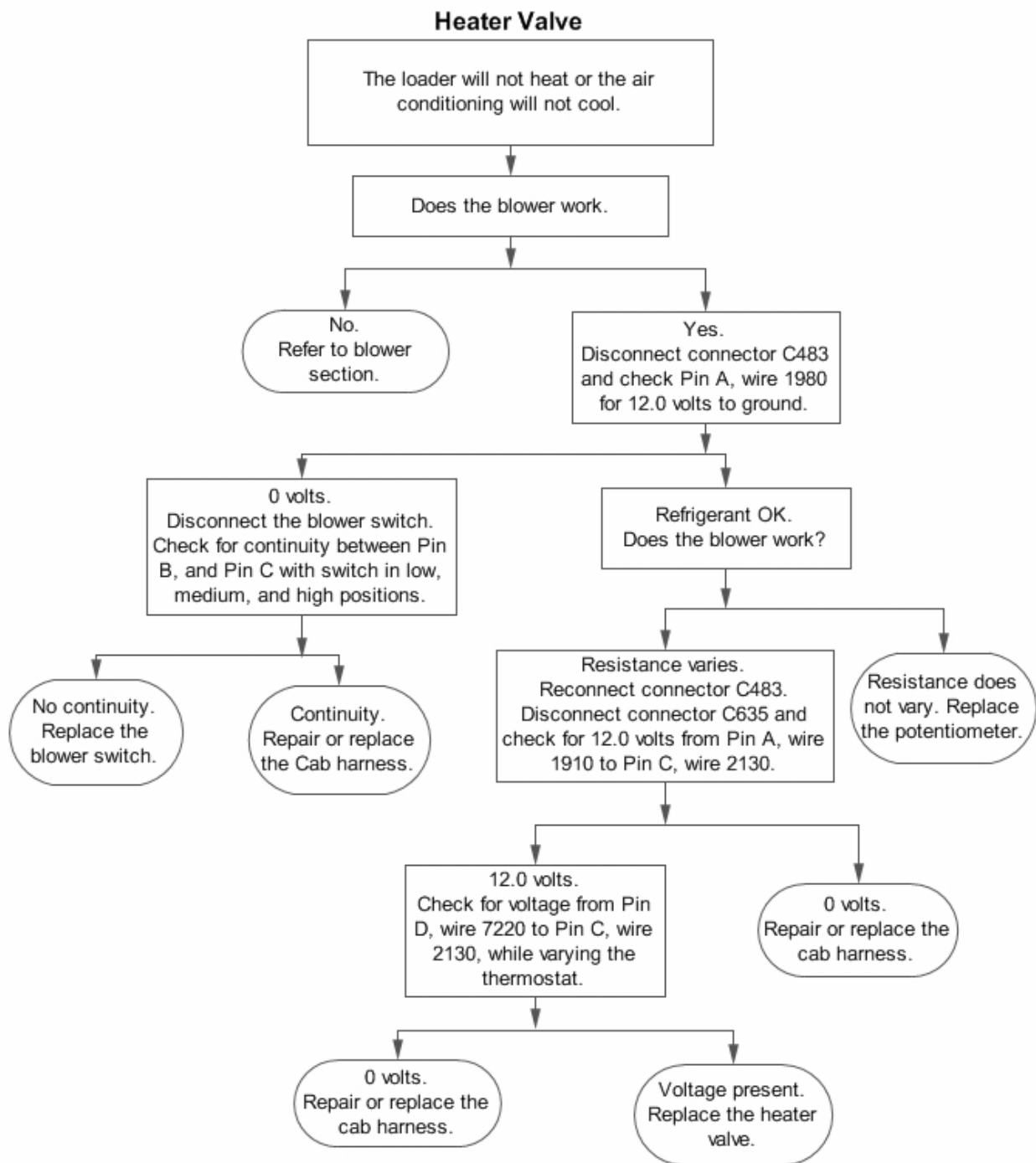

## TROUBLESHOOTING (CONT'D)

### Electrical System (Cont'd)

Figure 80-30-22

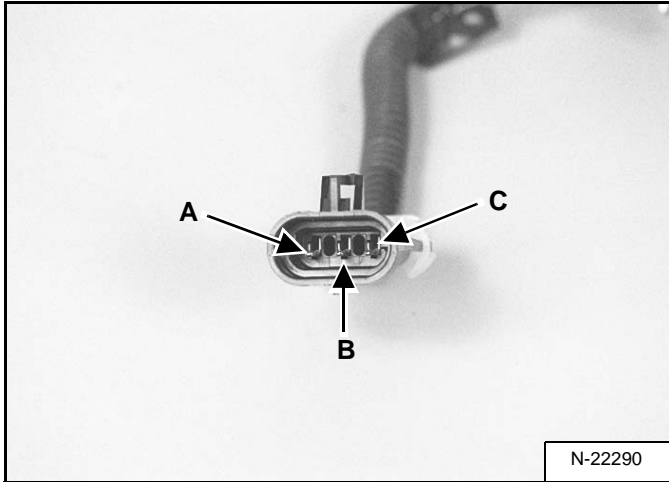

If there is voltage at the wiring harness, check the potentiometer [Figure 80-30-22] for resistance.

The resistance should be 10K Ohm between wire pin **A** and wire pin **C** frame [Figure 80-30-22].

If no resistance is found replace the potentiometer.

Figure 80-30-23

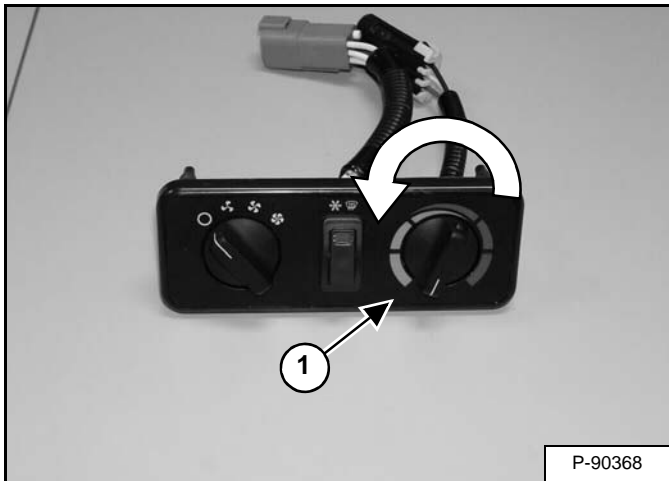

To check the resistance of the white wire, turn the potentiometer control (Item 1) [Figure 80-30-23] counterclockwise to the full A/C position.

Figure 80-30-24

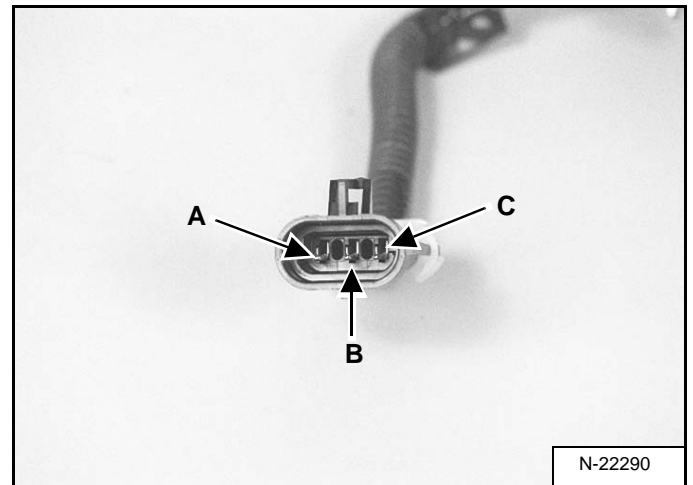

The resistance between the wire terminal **A** and wire terminal **B** frame [Figure 80-30-24] should be around 0 K Ohm.

Check the resistance between the wire terminal **C** and wire terminal **B** frame [Figure 80-30-24] should be around 10 K Ohm.

## COMPRESSOR (CONT'D)

### Oil Check

Figure 80-50-6

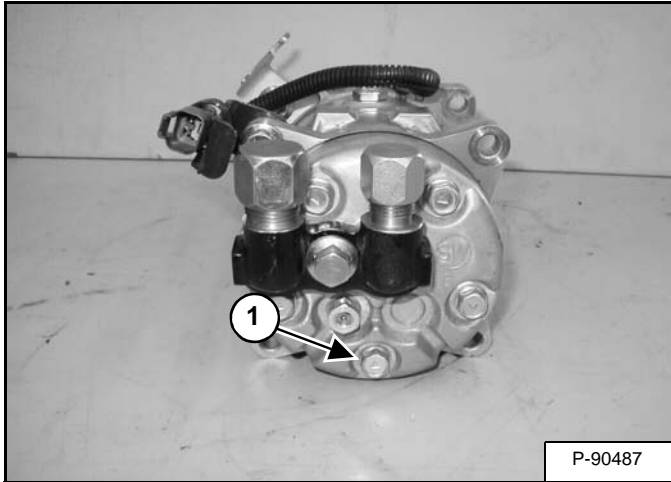
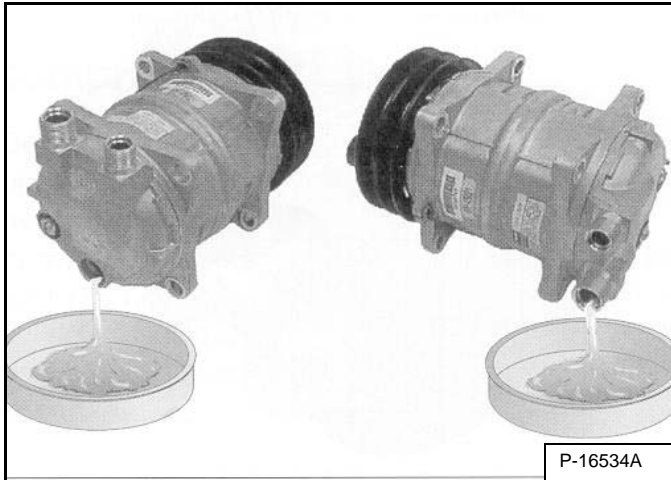

Figure 80-50-7



Remove the oil drain plug (Item 1) [Figure 80-50-6] and drain the oil through the connectors and the oil drain hole [Figure 80-50-7].

**Installation:** Tighten the oil drain plug to 13 - 15 N•m (9.4 - 10.8 ft-lb) torque.

Figure 80-50-8

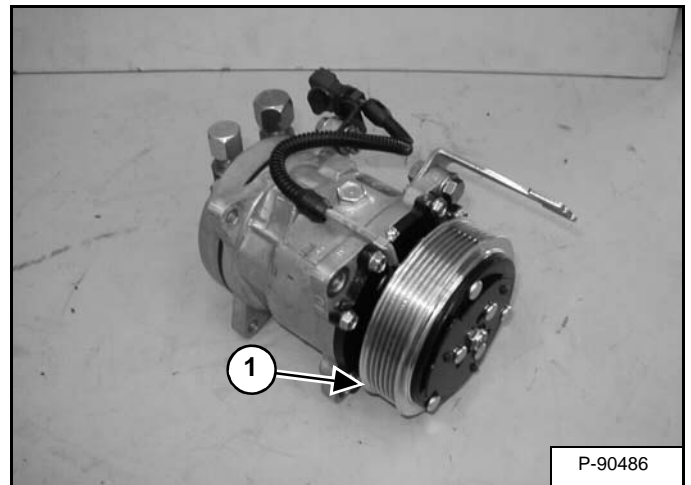

**NOTE:** After draining the oil through the drain hole and the connectors, extract the remaining oil through the discharge-side connector by rotating the drive pulley (Item 1) [Figure 80-50-8] several times by hand.

Measure the drained oil in a measuring cylinder.

Check the oil for contamination, dirt, metal shavings, or varnish color, discard the oil if contaminated.

**NOTE:** If metal shavings are found in the compressor oil, replace the complete compressor assembly.

Figure 80-50-9

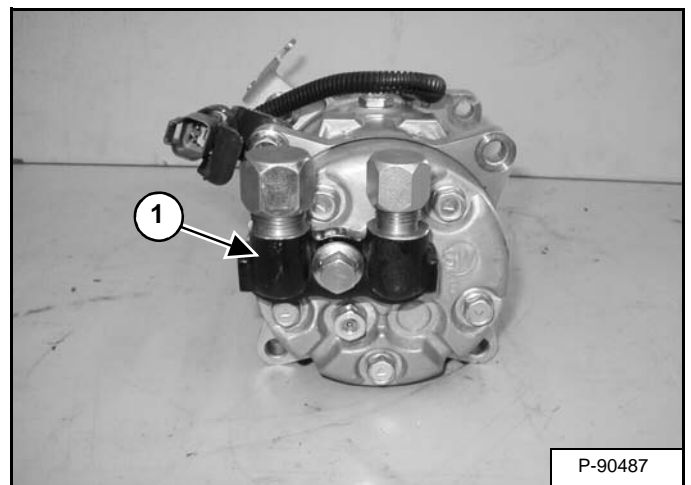

Add new compressor oil through the suction side connector (Item 1) [Figure 80-50-9].

**Installation:** Add 150 - 170 cc's of PAG 100 oil.

**NOTE:** The suction port on the compressor is marked with an SUC and is the larger port on the compressor.

## THERMOSTAT

### Description

The Electronic De-icing Thermostat (EDT) is a micro controller based module that measures evaporator coil temperature and cycles the compressor clutch to maintain a constant evaporator pressure. Onboard circuit protection and diagnostics are also built into the module.

**NOTE: The EDT has a six second delay before start up to protect the compressor clutch.**

The EDT will turn the clutch on when the evaporator coil temperature is above 2°C (35.6°F). If the EDT does not detect any malfunction, it will continue to operate and the status LED will be lit continuously. When the evaporator temperature is below -2°C (28.4°F), the EDT will turn off the clutch and status LED.

Figure 80-90-1

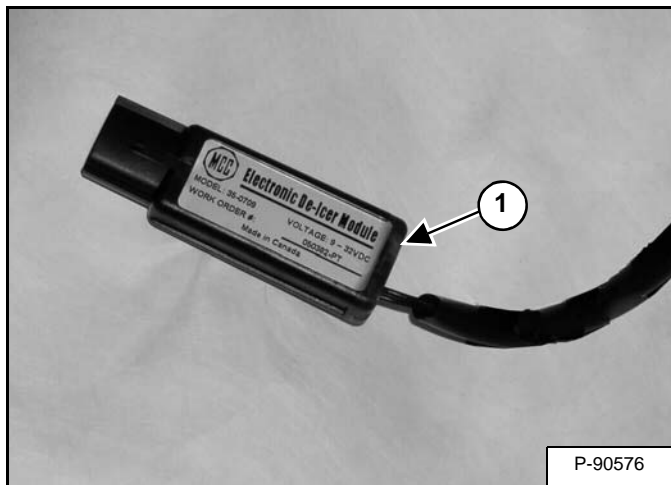

When the EDT detects an open or short from the temperature sensor, the status LED (Item 1) [Figure 80-90-1] will blink once per second and the output signal to the clutch will be turned off. The status LED will flash two times per second when EDT detects an open circuit (current draw less than 200 mA), short circuit or over current (current draw greater than 7A) from the clutch output. The status LED will flash three times per second when the compressor clutch is shorted to ground.

**NOTE: The EDT will attempt to restart every 20 seconds until the fault is repaired.**

**The EDT has the following protection built in:**

1. Over temperature
2. Over current from clutch output
3. Voltage (Above and below operational limits or reverse voltage)

4. Short circuit protection (Output shorted to ground)

5. Temperature sensor open and short detection

MALFUNCTION	DETECTION INTERVAL	STATUS LED
Temperature sensor	Continuous	1x per second
Temperature sensor open and short detection	At A/C start up	2x per second
Compressor clutch short to battery	Continuous	3x per second

## BLOWER FAN (CONT'D)

### Disassembly And Assembly (Cont'd)

Figure 80-130-8

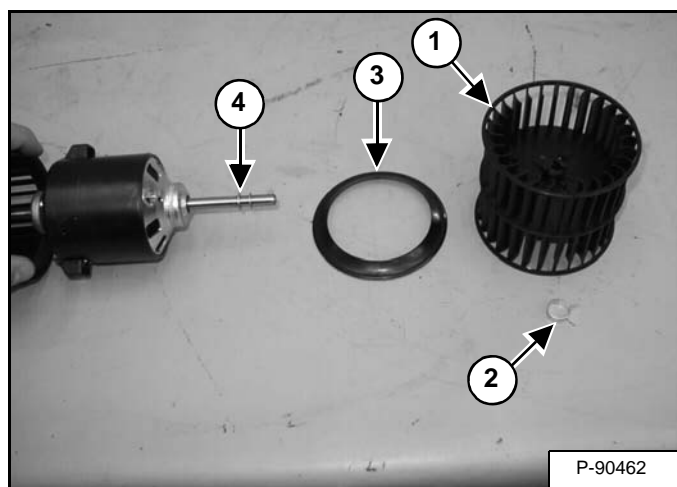

Remove the blower wheel (Item 1), inside clamp (Item 2), inside ring (Item 3), and spacers (Item 4) [Figure 80-130-8] from the blower motor shaft and inspect for wear.

**NOTE: The number and size of spacers (Item 4) [Figure 80-130-8] may vary.**

Repeat the procedure for the other blower wheel.

## TORQUE SPECIFICATIONS FOR BOLTS

### Torque For General SAE Bolts

The following table shows standard torque specifications for bolts with zinc phosphate coating. Bolts purchased from Bobcat that have zinc phosphate coating are specified by the letter H following the part number.

	Thread size	sae grade 5	sae grade 8
N•m (in-lb)	0.250	9,0 - 10,2 (80 - 90)	12,4 - 13,6 (110 - 120)
	0.3125	20,3 - 22,6 (180 - 200)	24,2 - 27,1 (215 - 240)
N•m (ft-lb)	0.375	34 - 38 (25 - 28)	47 - 54 (35 - 40)
	0.4375	54 - 61 (40 - 45)	81 - 88 (60 - 65)
	0.500	88 - 95 (65 - 70)	122 - 136 (90 - 100)
	0.5625	122 - 136 (90 - 100)	170 - 190 (125 - 140)
	0.625	170 - 190 (125 - 140)	240 - 260 (175 - 190)
	0.750	300 - 330 (220 - 245)	410 - 450 (300 - 330)
	0.875	450 - 490 (330 - 360)	645 - 710 (475 - 525)
	1.000	645 - 710 (475 - 525)	985 - 1085 (725 - 800)
	1.125	880 - 975 (650 - 720)	1425 - 1600 (1050 - 1175)
	1.250	1200 - 1360 (900 - 1000)	2000 - 2200 (1475 - 1625)
	1.375	1630 - 1830 (1200 - 1350)	2720 - 2980 (2000 - 2200)
	1.500	2040 - 2240 (1500 - 1650)	3530 - 3870 (2600 - 2850)
	1.625	2720 - 2980 (2000 - 2800)	4680 - 5150 (3450 - 3800)
	1.750	3390 - 3730 (2500 - 2750)	5830 - 6500 (4300 - 4800)
1.875	4270 - 4750 (3150 - 3500)	7450 - 8300 (5500 - 6100)	
2.000	5150 - 5700 (3800 - 4200)	8800 - 9800 (6500 - 7200)	

TRACTION LOCK .....	60-120-1
TRANSPORTING LOADER ON A TRAILER .....	10-40-1
TROUBLESHOOTING .....	80-30-1
TURBOCHARGER .....	70-110-1
TWO-SPEED / BRAKE VALVE .....	30-70-1
WINDOW (REAR) .....	50-130-1
WINDOW (SIDE) .....	50-132-1
WINDOW (TOP) .....	50-131-1

CLICK HERE TO **DOWNLOAD** THE COMPLETE MANUAL

- Thank you very much for reading the preview of the manual.
- You can download the complete manual from: [www.heydownloads.com](http://www.heydownloads.com) by clicking the link below



- Please note: If there is no response to CLICKING the link, please download this PDF first and then click on it.

CLICK HERE TO **DOWNLOAD** THE COMPLETE MANUAL