



Bobcat®

Service Manual

S330 Skid-Steer Loader

S/N A02060001 & Above
S/N A02160001 & Above

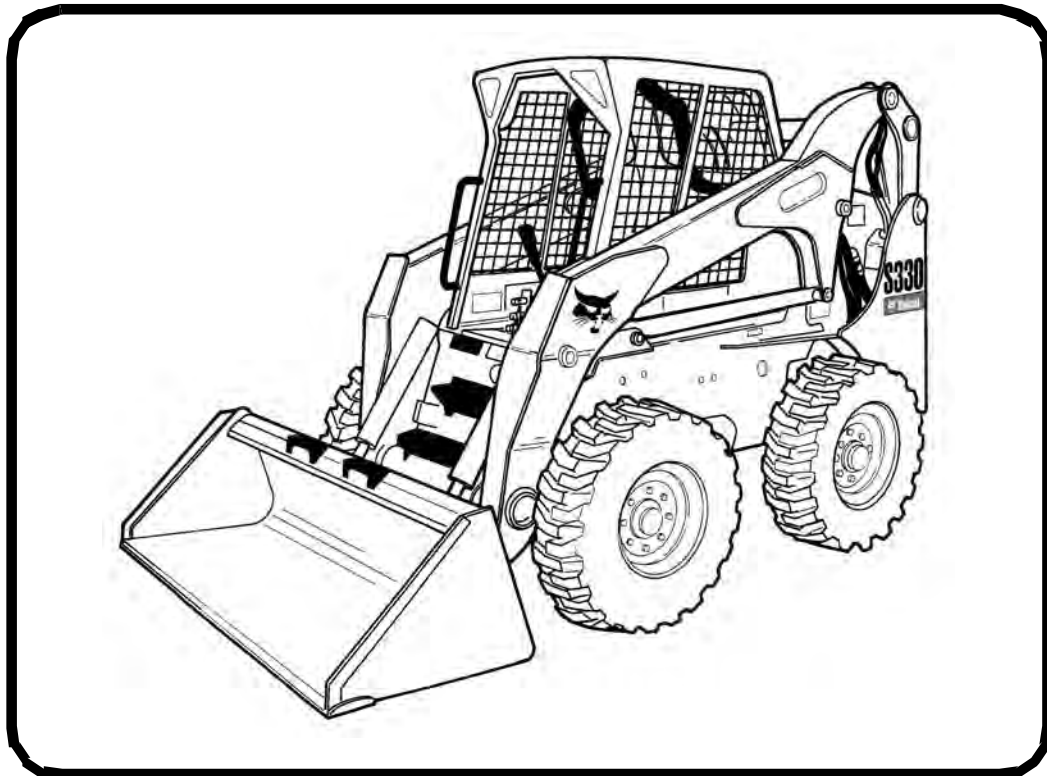

EQUIPPED WITH
BOBCAT INTERLOCK
CONTROL SYSTEM (BICS™)



CLICK HERE TO **DOWNLOAD** THE COMPLETE MANUAL

- Thank you very much for reading the preview of the manual.
- You can download the complete manual from: www.heydownloads.com by clicking the link below



- Please note: If there is no response to CLICKING the link, please download this PDF first and then click on it.

CLICK HERE TO **DOWNLOAD** THE COMPLETE MANUAL



Bobcat®

SAFETY AND MAINTENANCE (CONT'D)

TIRE MAINTENANCE	10-160-1
Mounting	10-160-2
Rotating	10-160-2
Wheel Nuts	10-160-1
TOWING THE LOADER	10-50-1
Procedure	10-50-1
TRANSPORTING THE LOADER ON A TRAILER	10-40-1
Fastening	10-40-1
Loading And Unloading	10-40-1

TIGHTEN ALL HARDWARE PER SIZE TO GRADE 5 TORQUE (SEE STANDARD TORQUE SPECIFICATIONS FOR BOLTS, SECTION SPEC-01) UNLESS OTHERWISE SPECIFIED.

SPECIFICATIONS SUBJECT TO CHANGE WITHOUT NOTICE AND STANDARD ITEMS MAY VARY.

TRANSPORTING THE LOADER ON A TRAILER

Loading And Unloading



AVOID SERIOUS INJURY OR DEATH

Adequately designed ramps of sufficient strength are needed to support the weight of the machine when loading onto a transport vehicle. Wood ramps can break and cause personal injury.

W-2058-0807

Be sure the transport and towing vehicles are of adequate size and capacity for weight of loader. (See Capacities on Page SPEC-10-4.)

Figure 10-40-1



A loader with an empty bucket or no attachment must be loaded backward onto the transport vehicle [Figure 10-40-1].

The rear of the trailer must be blocked or supported (Item 1) [Figure 10-40-1] when loading or unloading the loader to prevent the front end of the trailer from raising up.

Fastening

Figure 10-40-2

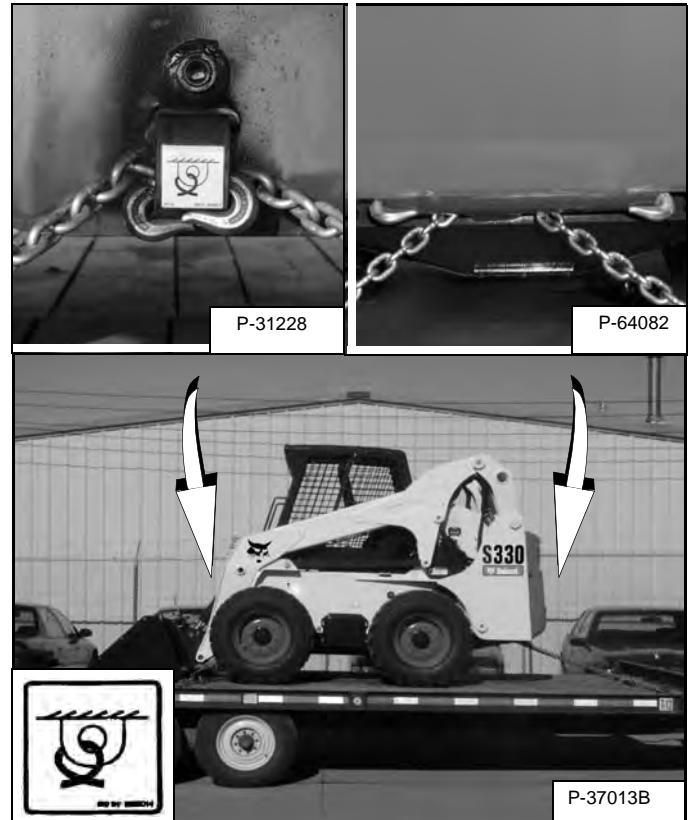

Use the following procedure to fasten the Bobcat Loader to the transport vehicle to prevent the loader from moving during sudden stops or when going up or down slopes [Figure 10-40-2].

- Lower the bucket or attachment to the floor.
- Stop the engine.
- Engage the parking brake.
- Install chains at the front and rear loader tie down positions [Figure 10-40-2]
- Fasten each end of the chain to the transport vehicle.

REMOTE START TOOL (SERVICE TOOL) KIT - 6689779

Description

The Remote Start Tool (Service Tool) Kit is a replacement tool for MEL 1563 Remote Start Tool and MEL 1400B - BOSS® Diagnostic Tool.

The Remote Start Tool (Service Tool) Kit, P/N 6689779, can be used to service older loaders with the BOSS® system using the supplied BOSS® Service Tool Harness P/N 6689745.

The Remote Start Tool (Service Tool) Kit, P/N 6689779, can be used to service newer loaders using the supplied harness P/N 6689747.

A computer can be connected to the Remote Start Tool (Service Tool) for diagnostics and software updates using the computer harness P/N 6689746 in conjunction with the loader harness.

AIR CLEANER SERVICE

Replacing Filter Elements

Figure 10-80-1



Figure 10-80-2

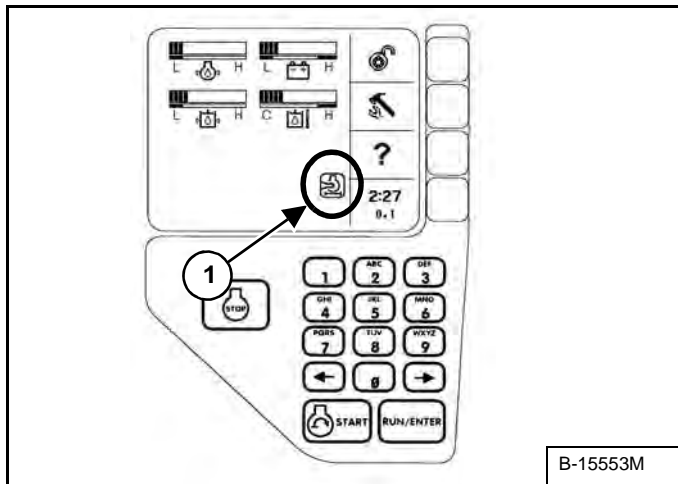

It is important to change the air filter element only when necessary. The Service indicator (Item 1) will FLASH and service code **[M0117]** (Air Filter Plugged) will show in the Data Display (Item 2) when the Information button (Item 3) **[Figure 10-80-1]** is held for two seconds.

The Air Cleaner icon on the Deluxe Instrumentation Panel, if equipped, will be ON (Item 1) **[Figure 10-80-2]**.

Replace the inner filter every third time the outer filter is replaced or as indicated.

Outer Filter

Figure 10-80-3



Remove the wing nut and remove the dust cover (Item 1) **[Figure 10-80-3]**.

Figure 10-80-4

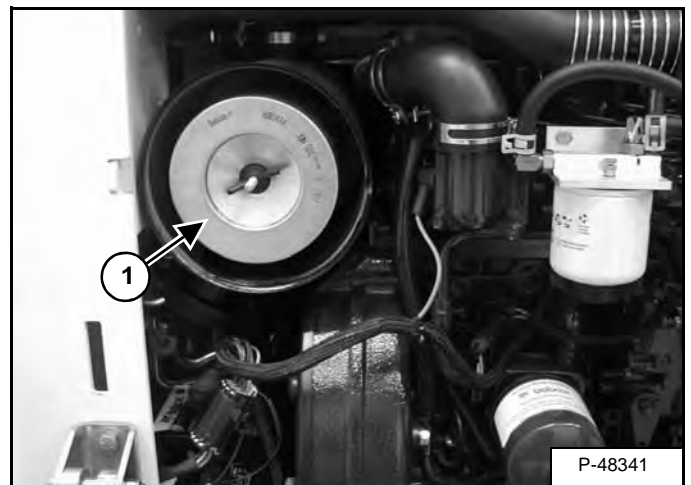

Remove the wing nut and pull the outer filter element (Item 1) **[Figure 10-80-4]** out and discard.

NOTE: Make sure all sealing surfaces are free of dirt and debris.

Install new filter. Push all the way in until it contacts the base of the housing. Install wing nut.

Install the dust cover and the wing nut **[Figure 10-80-3]**.

HYDRAULIC / HYDROSTATIC SYSTEM

Checking And Adding Fluid

Put the loader on a level surface, lower the lift arms and tilt the Bob-Tach fully back.

Stop the engine.

Figure 10-120-1

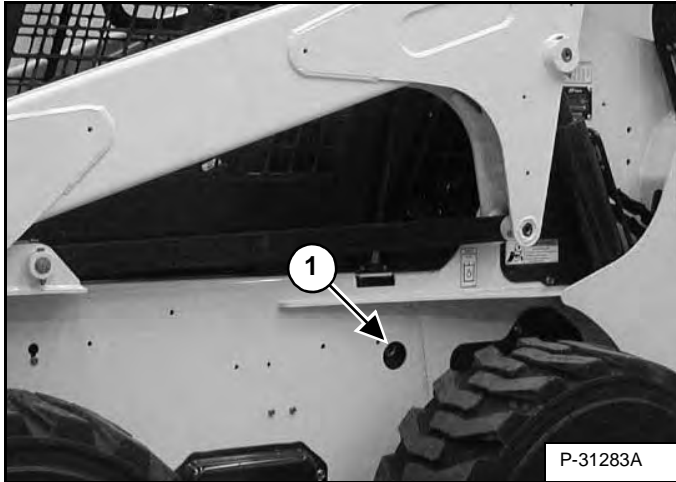

Check the fluid level in the sight gauge (Item 1) [Figure 10-120-1].

Figure 10-120-2

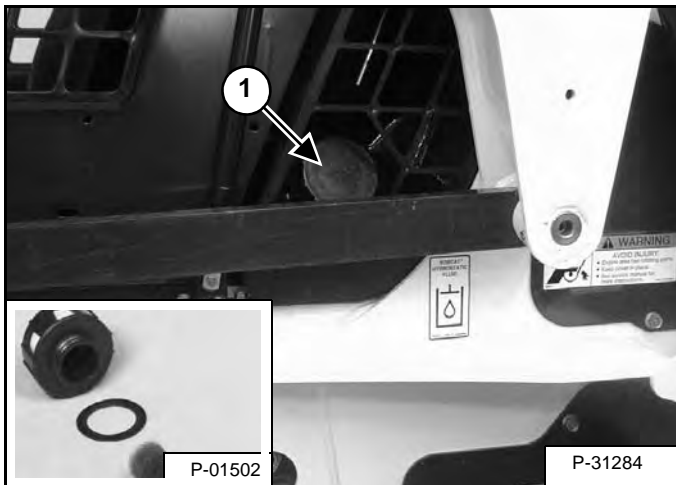

Remove the fill cap (Item 1) [Figure 10-120-2].

Add fluid [Figure 10-120-3] as needed to bring the level to the center of the sight gauge.

NOTE: Before installing the fill cap, make sure the rubber gasket is installed on fill cap (Inset) [Figure 10-120-2].

Install the fill cap [Figure 10-120-2].

Hydraulic / Hydrostatic Fluid Chart

Figure 10-120-3

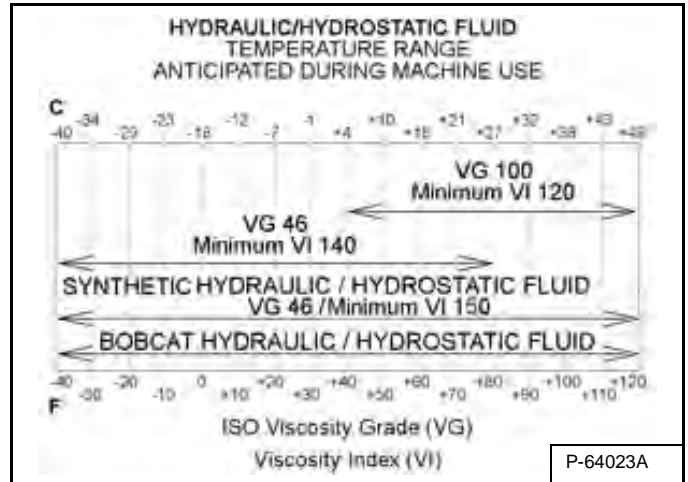

Use only recommended fluid in the hydraulic system. (See Specifications on Page SPEC-40-1.) and [Figure 10-120-3].

BOB-TACH (HAND LEVER)

Inspection And Maintenance

Figure 10-140-1

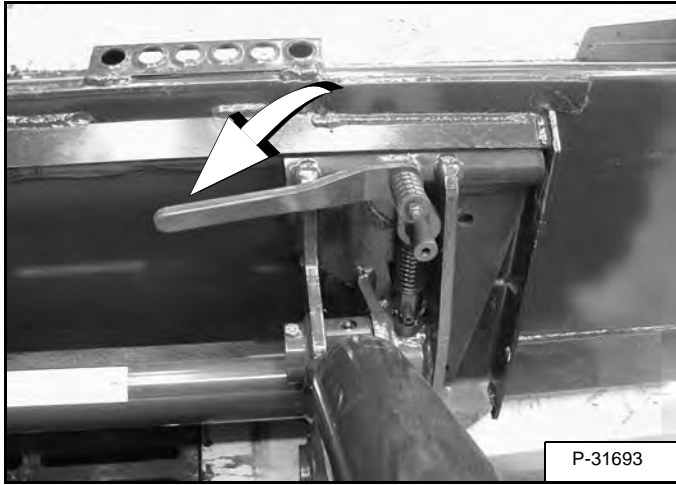

Move the Bob-Tach levers down to engage the wedges [Figure 10-140-1].

The levers and wedges must move freely.

WARNING

Bob-Tach wedges must extend through the holes in attachment. Levers must be fully down and locked. Failure to secure wedges can allow attachment to come off and cause injury or death.

W-2102-0588

Figure 10-140-2

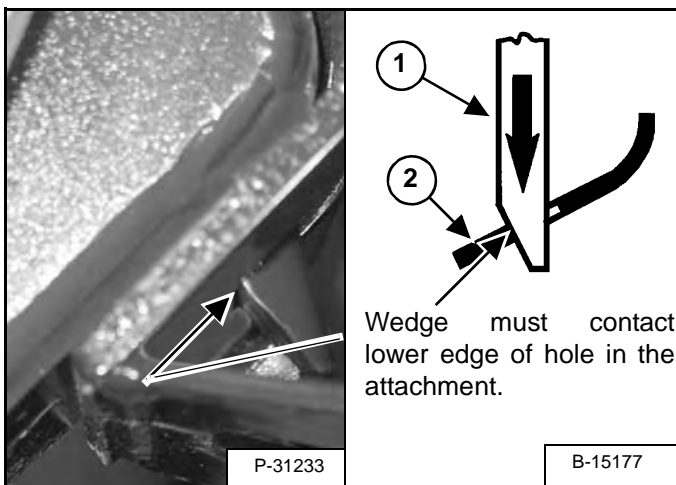

The wedges (Item 1) [Figure 10-140-2] must extend through the holes in the attachment mounting frame.

The spring loaded wedge (Item 1) must contact the lower edge of the hole in the attachment (Item 2) [Figure 10-140-2].

If the wedge does not contact the lower edge of the hole [Figure 10-140-2], the attachment will be loose and can come off the Bob-Tach.

Figure 10-140-3

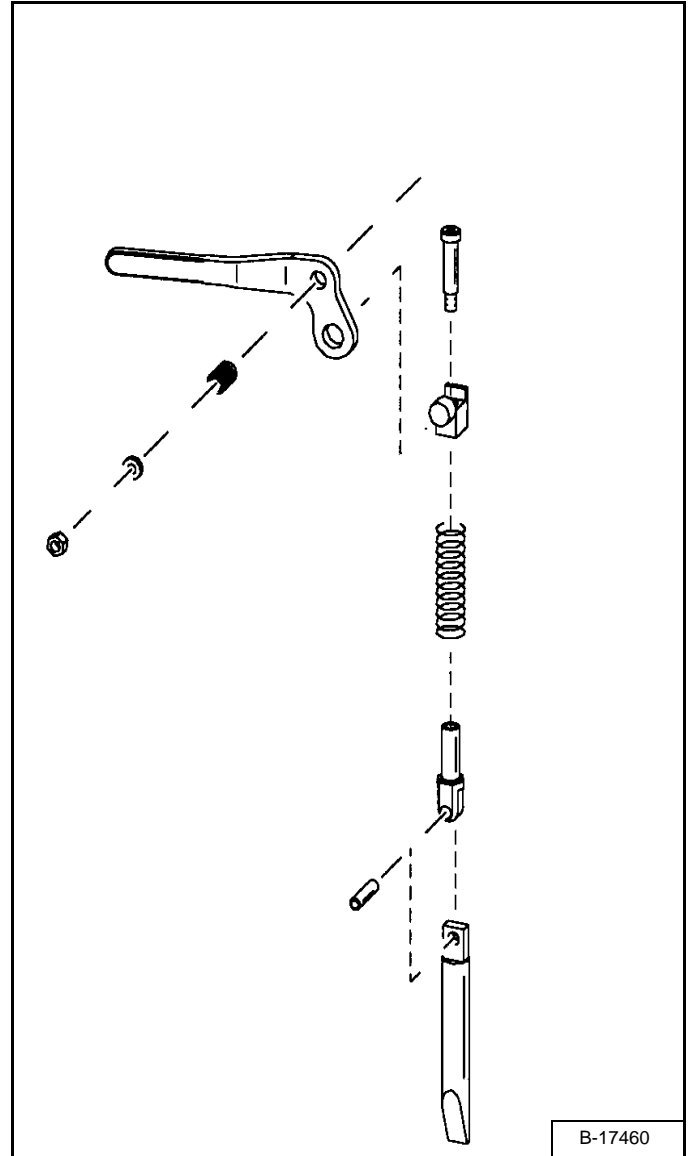

Inspect the mounting frame on the attachment and Bob-Tach, linkages and wedges for excessive wear or damage [Figure 10-140-3]. Replace any parts that are damaged, bent or missing. Keep all fasteners tight.

Look for cracked welds. Contact your Bobcat dealer for repair or replacement parts.

Lubricate the wedges. (See SERVICE SCHEDULE on Page 10-70-1) (See LUBRICATING THE LOADER on Page 10-150-1.)

PIVOT PINS

Inspection And Maintenance

Figure 10-180-1

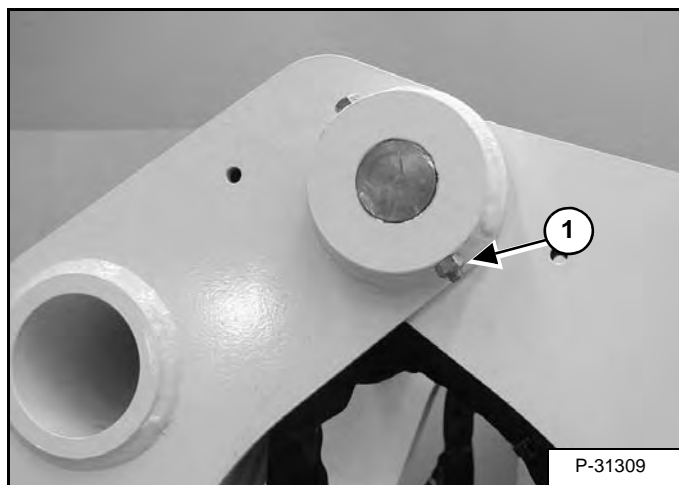

All lift arm and cylinder pivots have a large pin held in position with a retainer bolt and lock nut (Item 1) **[Figure 10-180-1]**.

Check that the lock nuts are tightened to 35 - 40 ft.-lb. (48 - 54 N•m) torque.

HYDRAULIC SYSTEM (CONT'D)

HYDRAULIC SYSTEM INFORMATION	20-10-1
Glossary Of Hydraulic / Hydrostatic Symbols	20-10-1
Troubleshooting	20-10-5
HYDRAULIC/HYDROSTATIC FILTERS	20-80-1
Charge Filter Housing Removal And Installation	20-80-3
Description	20-80-1
Housing Removal And Installation	20-80-1
LIFT ARM BYPASS CONTROL VALVE	20-50-1
Description	20-50-1
Disassembly And Assembly	20-50-3
Removal And Installation	20-50-2
Testing	20-50-1
MAIN RELIEF VALVE	20-30-1
Adjusting	20-30-4
Description	20-30-1
Removal And Installation	20-30-5
Testing	20-30-2
OIL COOLER	20-100-1
Description	20-100-1
Removal And Installation	20-100-1
REAR AUXILIARY DIVERTER VALVE	20-120-1
Description	20-120-1
Disassembly And Assembly	20-120-4
Removal And Installation	20-120-2
Solenoid Testing	20-120-1

TIGHTEN ALL HARDWARE PER SIZE TO GRADE 5 TORQUE (SEE STANDARD TORQUE SPECIFICATIONS FOR BOLTS, SECTION SPEC-01) UNLESS OTHERWISE SPECIFIED.

SPECIFICATIONS SUBJECT TO CHANGE WITHOUT NOTICE AND STANDARD ITEMS MAY VARY.

**HYDRAULIC/HYDROSTATIC SCHEMATIC
WITH SJC OPTION
S330 (S/N A02060001 AND ABOVE)
(S/N A02160001 AND ABOVE)**

(PRINTED APRIL: 2008)

V-1227legend

[Printable Version Click Here](#)







LEGEND

- | | | | |
|--|--|---|--|
| <p>① RESERVOIR:
Capacity 18.8 qt. (17,8 L)</p> <p>② SPRING LOADED FILTER BY-PASS VALVE: 45-55 PSI (3,1-3,8 bar)</p> <p>③ DIFFERENTIAL PRESSURE SWITCH:
36-44 PSI (2,5-3,0 bar)
Normally Closed</p> <p>④ DRIVE MOTOR SHUTTLE VALVE</p> <p>⑤ RELIEF/REPLENISHING VALVE - HIGH PRESSURE: 5075 PSI (350 bar)</p> <p>⑥ RELIEF VALVE - CHARGE INLET:
360 PSI (24,8 bar)
at High Engine Idle
With 140 degrees F. (60 degrees C.) Fluid</p> <p>⑦ FRONT AUXILIARY MANUAL PRESSURE BLEED-OFF VALVE</p> <p>⑧ HYDRAULIC PUMP Gear Type
20.7 GPM (78,4 L/min.) at High Engine Idle</p> <p>⑨ RELIEF VALVE - MAIN:
3250-3350 PSI (224-231 bar)
at Front Quick Couplers</p> <p>⑩ PORT RELIEF/ANTICAVITATION VALVE
4000 PSI (276 bar)</p> <p>⑪ ANTICAVITATION VALVE</p> <p>⑫ SOLENOID ACTIVATED DIRECTIONAL CONTROL VALVE - AUXILIARY</p> <p>⑬ PORT RELIEF/ANTICAVITATION VALVE:
. (Optional)
3500 PSI (241,3 bar)</p> <p>⑭ LOAD CHECK VALVE</p> <p>⑮ LIFT CYLINDER SPOOL - MADE TO RESTRICT FLOW DURING BOOM DOWN BUT NOT DURING BOOM UP</p> | <p>⑯ SOLENOID ACTIVATED DIRECTIONAL CONTROL VALVE - BICS CONTROL</p> <p>⑰ PILOTED ACTIVATED DIRECTIONAL CONTROL VALVE - TILT CONTROL</p> <p>⑱ PILOTED ACTIVATED DIRECTIONAL CONTROL VALVE - LIFT CONTROL</p> <p>⑲ PULL BUTTON ACTIVATED DIRECTIONAL CONTROL VALVE - LIFT ARM BY-PASS</p> <p>⑳ PILOTED ACTIVATED DIRECTIONAL CONTROL VALVE - UNLOADING SPOOL</p> <p>㉑ PILOTED ACTIVATED DIRECTIONAL CONTROL VALVE - FLOW CONTROL SPOOL</p> <p>㉒ FLOW DIVIDER ADJUSTMENT VALVE</p> <p>㉓ SOLENOID ACTIVATED DIRECTIONAL CONTROL VALVE - BASE</p> <p>㉔ SOLENOID ACTIVATED DIRECTIONAL CONTROL VALVE - ROD</p> <p>㉕ LOAD SHUTTLE VALVE - BLEED OFF</p> <p>㉖ SOLENOID ACTIVATED DIRECTIONAL CONTROL VALVE - TWO COIL</p> <p>㉗ PILOT ACTIVATED DIRECTIONAL CONTROL VALVE - REAR AUXILIARY</p> <p>㉘ RESTRICTOR - 0.031 inch (0,8 mm)</p> <p>㉙ RELIEF VALVE: 3300 PSI (228 bar)</p> <p>㉚ CHARGE PRESSURE SENSOR</p> <p>㉛ FILTER - HYDRAULIC (CANISTER)</p> <p>㉜ FILTER - CASE DRAIN (SINTERED BRONZE)</p> | <p>㉝ FILTER - BICS CONTROL VALVE (SCREEN)</p> <p>㉞ CHECK VALVE - BUCKET POSITION VALVE</p> <p>㉟ RESTRICTION</p> <p>㊱ VARIABLE CAPACITY DISPLACEMENT BI-DIRECTIONAL HYDROSTATIC PUMP</p> <p>㊲ SHUTTLE RELIEF VALVE
(Not Adjustable - Factory Set)
200 PSI (13,8 bar)</p> <p>㊳ FIXED CAPACITY DISPLACEMENT BI-DIRECTIONAL HYDROSTATIC MOTOR</p> <p>㊴ CHECK VALVE - With 80 PSI (5,5 bar) Spring</p> <p>㊵ SOLENOID ACTIVATED DIRECTIONAL CONTROL VALVE - BUCKET POSITION VALVE (ON/OFF)</p> <p>㊶ CHECK VALVE - BICS CONTROL VALVE</p> <p>㊷ RESTRICTION - 0.343 inch (8,7 mm)</p> <p>㊸ FILTER - Bob-Tach Valve</p> <p>㊹ PILOT ACTIVATED DIRECTIONAL CONTROL VALVE - HYDRAULIC POWERED BOB-TACH</p> <p>㊺ RESTRICTION - 0.089 inch (2,26 mm)</p> <p>㊻ RESTRICTION - 0.025 inch (0,6 mm)</p> <p>㊼ RELIEF VALVE - 2000 PSI (137 bar)</p> <p>㊽ RELIEF VALVE - 1200 PSI (83 bar)</p> <p>㊾ SOLENOID ACTIVATED DIRECTIONAL CONTROL VALVE (TWO COIL)</p> | <p>㊿ FIXED CAPACITY DISPLACEMENT HYDRAULIC MOTOR</p> <p>① ANTICAVITATION VALVE</p> <p>② PROPORTIONAL RELIEF VALVE – (Fan Speed Regulator):
1566 - 1784 PSI (108 - 123 bar)</p> <p>③ CHARGE PUMP -
13.6 GPM (51,5 L/min) at High Engine Idle</p> <p>④ CHECK VALVE - With 300 PSI (20,7 bar) Spring with 0.016 inch (0,40 mm) orifice</p> <p>⑤ SOLENOID ACTIVATED CONTROL VALVE - FORWARD/REVERSE</p> <p>⑥ SERVO PISTON -Swash Plate</p> <p>⑦ POSITION SENSOR -Swash Plate</p> <p>⑧ SWITCH – CHARGE PRESSURE – Fan Filter</p> <p>⑨ SWITCH – HYD. TEMP. – Hyd. Filter</p> <p>⑩ FILTER - HYDRAULIC (CANISTER)</p> <p>⑪ SPRING LOADED FILTER BY-PASS VALVE: 75-83 PSI (5,2-5,7 bar)</p> |
|--|--|---|--|

NOTE: Unless otherwise specified, springs have NO significant pressure value.

HYDRAULIC SYSTEM INFORMATION (CONT'D)

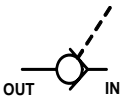
Glossary Of Hydraulic / Hydrostatic Symbols (Cont'd)

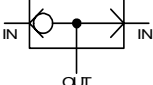
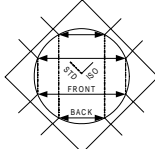
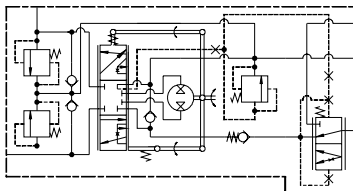
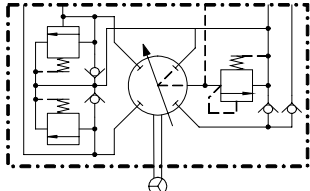
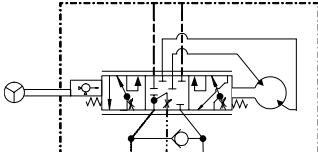
SYMBOL	DESCRIPTION	SYMBOL	DESCRIPTION
	<p>NON-RETURN VALVE (Check Valve) - Used as Replenishing Valve, Lock Check Valve or Anticavitation Valve - Opens if the Inlet pressure is higher than the Outlet pressure. Often contains internal spring which has NO significant pressure value.</p>		<p>TWO PORTS and CLOSED FLOW PATHS</p>
	<p>SPRING LOADED VALVE (bypass Valve) - Opens if the Inlet pressure is greater than the Outlet pressure plus the spring pressure.</p>		<p>SOLENOID ACTIVATED DIRECTIONAL CONTROL VALVE (Two Position) - controlled by an electric solenoid (with return spring).</p>
	<p>PILOT CONTROLLED NON-RETURN VALVE- It is possible to open the valve by pilot pressure.</p>		<p>PILOT ACTIVATED DIRECTIONAL CONTROL VALVE (Two Position) - controlled by pressure (with return spring).</p>
	<p>SHUTTLE VALVE - The Inlet port connected to the higher pressure is automatically connected to the Outlet port while the other Inlet port is closed.</p>		<p>MANUALLY ACTIVATED DIRECTION CONTROL VALVE (Variable Position) Joystick Controlled, variable pressure to shift the pilot activated directional control valve spool.</p> <p>MANUALLY ACTIVATED FLOW CONTROL VALVE (Two Position) allows for changing pilot flow to control switching joystick functions for STD / ISO Control (Excavators Only).</p>
			<p>STEERING CONTROL VALVE (Variable Position) - Used for controlling the hydraulic flow for the steering cylinders in relationship to the amount the steering wheel is rotated.</p>
			
			

CYLINDER (LIFT) (CONT'D)

Assembly

Use the following tools to assemble the cylinder:

MEL1396 - Seal Installation Tool
MEL1033 - Rod Seal Installation Tool
Piston Ring Compressor
Spanner Wrench

Figure 20-20-14

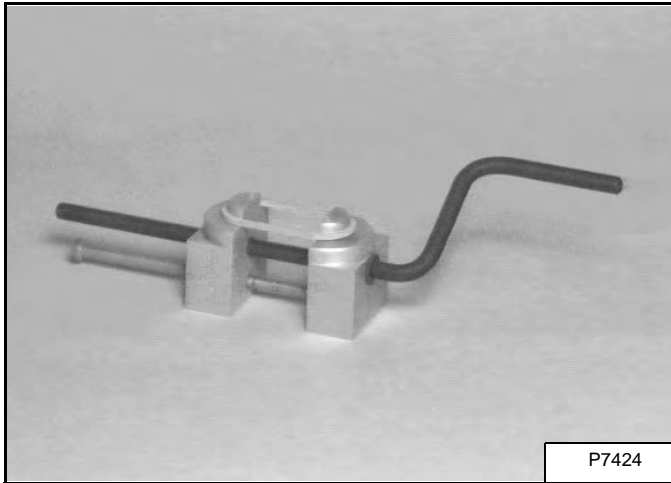

Wash the cylinder parts in solvent and air dry them.

Inspect the cylinder parts for nicks, scratches or other damage. Replace any damaged parts.

Always install new O-rings and seals during assembly.

Lubricate all O-rings and seals with hydraulic oil during installation.

Install the new seal on the tool and slowly stretch it until it fits the piston **[Figure 20-20-14]**.

Allow the seal to stretch for 30 seconds before installing it on the piston.

Figure 20-20-15

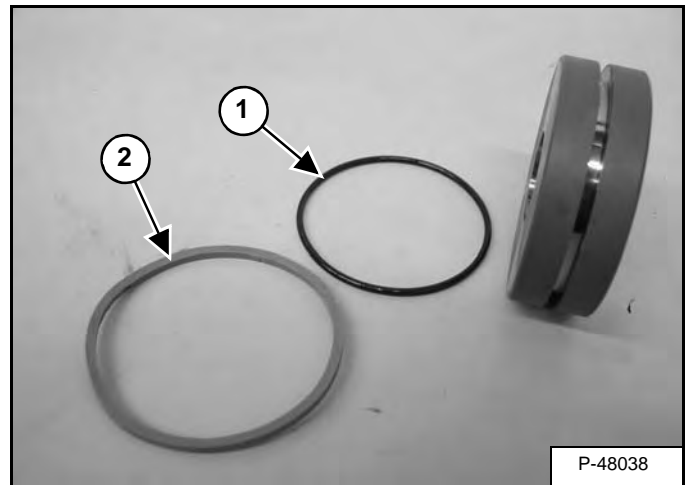

Install the O-ring (Item 1) and seal (Item 2) **[Figure 20-20-15]** on the cylinder piston.

Figure 20-20-16

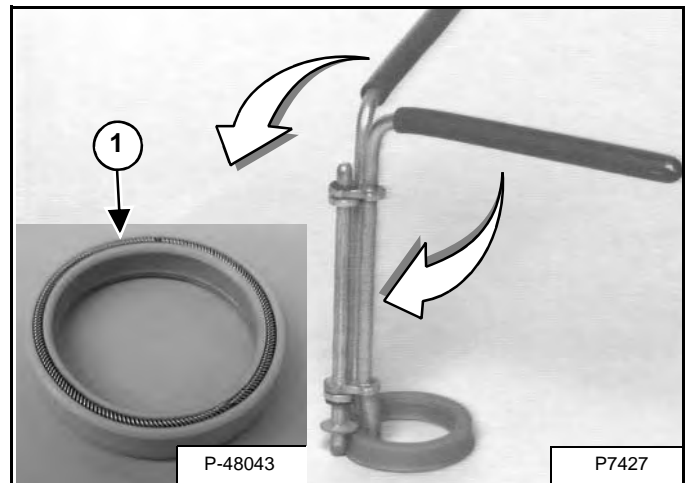

Install the rod seal on the rod seal tool **[Figure 20-20-16]**.

NOTE: During installation the spring side of the seal (Item 1) **[Figure 20-20-16]** must be installed toward the inside of the cylinder.

Rotate the handles to collapse the rod seal **[Figure 20-20-16]**.

CYLINDER (TILT) (CONT'D)

Assembly (Cont'd)

Figure 20-21-21

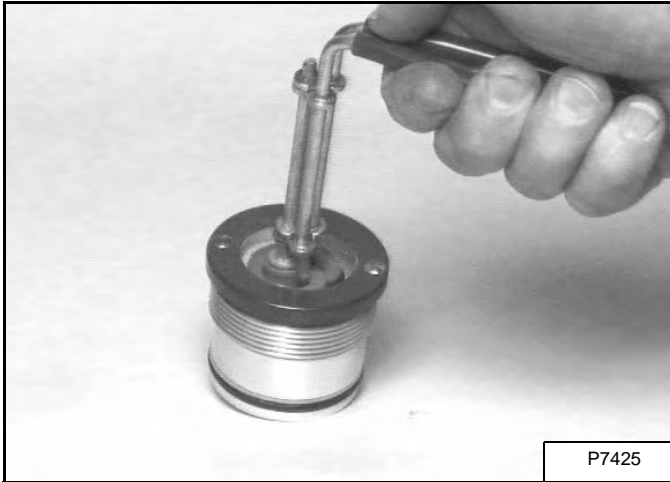

Install the rod seal in the head [Figure 20-21-21].

Figure 20-21-22

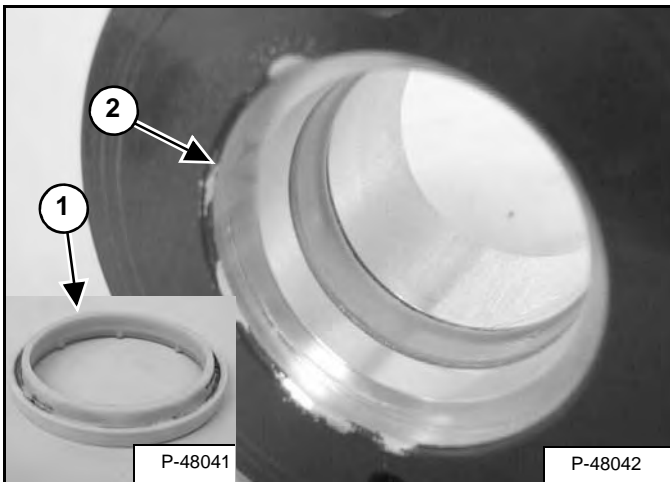

Install the wiper seal, with the wiper side of the seal (Item 1) toward the outside of the head (Item 2) [Figure 20-21-22].

Figure 20-21-23

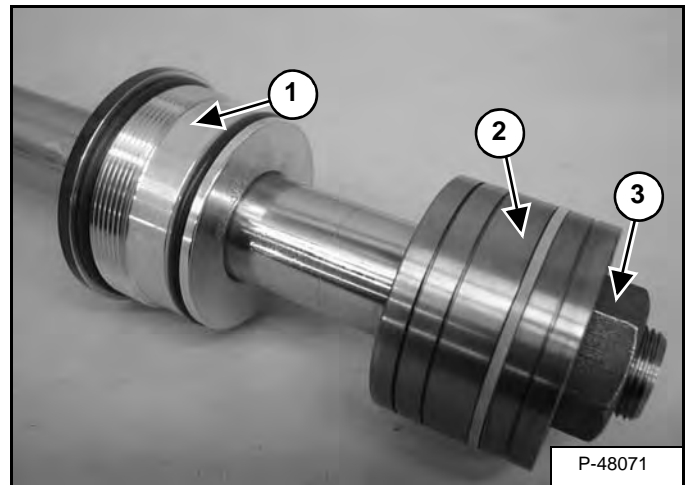

NOTE: Clean and dry the threads before installing the nut. Install the new nut from the kit.

Install the head (Item 1), piston (Item 2) and nut (Item 3) [Figure 20-21-23].

Tighten the nut (Item 3) [Figure 20-21-23] to 100 ft.-lb. (136 N•m) torque.

Figure 20-21-24

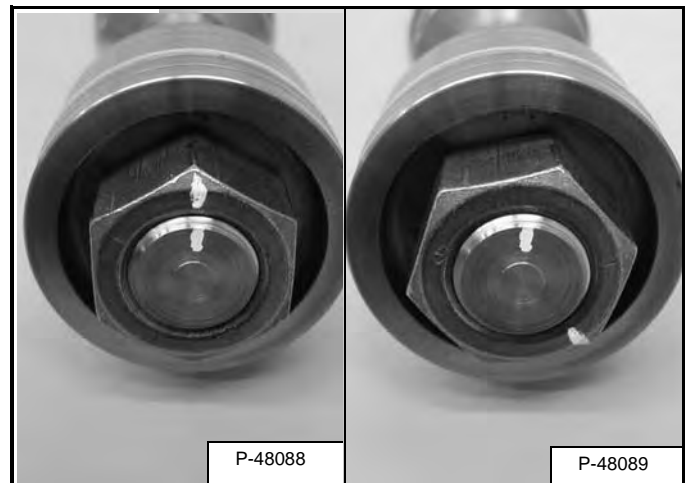

Mark the end of the shaft and nut [Figure 20-21-24]. Tighten the nut an additional 135 degrees or 2-1/4 flats [Figure 20-21-24].

MAIN RELIEF VALVE

Description

The main relief valve limits the hydraulic system pressure by opening at a certain pressure and allowing the hydraulic oil to flow back to the hydraulic reservoir. (See Hydraulic System on Page SPEC-10-3.)

The main relief valve is adjustable and is located on the hydraulic control valve near the bottom, facing the front of the loader.

HYDRAULIC CONTROL VALVE (STANDARD) (CONT'D)

Removal And Installation (Cont'd)

Figure 20-40-12

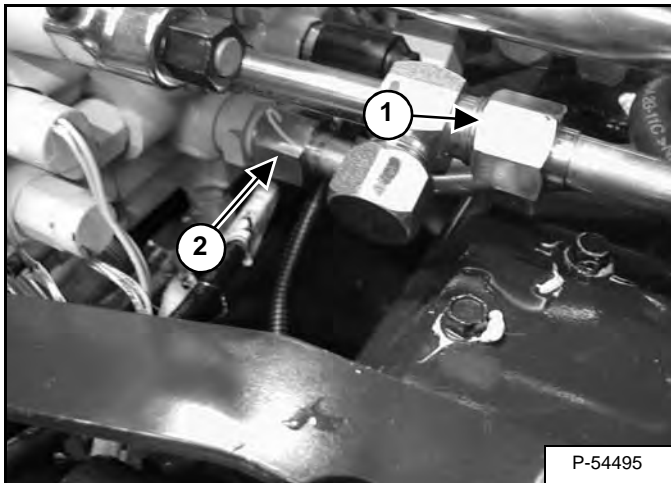

Disconnect the tilt tubeline (Item 1) [Figure 20-40-12] from the control valve.

Disconnect the lift tubeline (Item 2) [Figure 20-40-12] from the control valve.

Figure 20-40-13

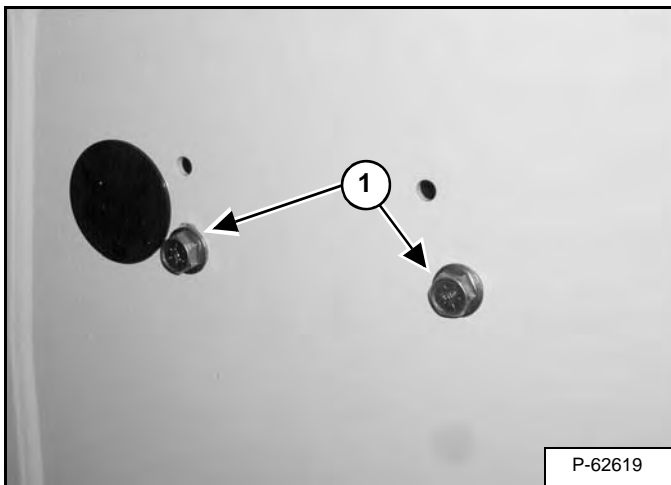

Remove the two control valve mount bolts (Item 1) [Figure 20-40-13] located on the outside of the frame.

Installation: Torque the bolts (Item 1) [Figure 20-40-13] to 90 - 100 ft.-lb. (123 - 135 N•m).

Remove the control valve from the loader.

HYDRAULIC CONTROL VALVE (STANDARD) (CONT'D)

Lift Spool And Detent Removal And Installation

The tool listed will be needed to do the following procedure:

MEL1278 - Detent Tool

MEL1285 - Detent Spring Tool

Remove the end cap/spool lock block from the control valve.

Figure 20-40-44

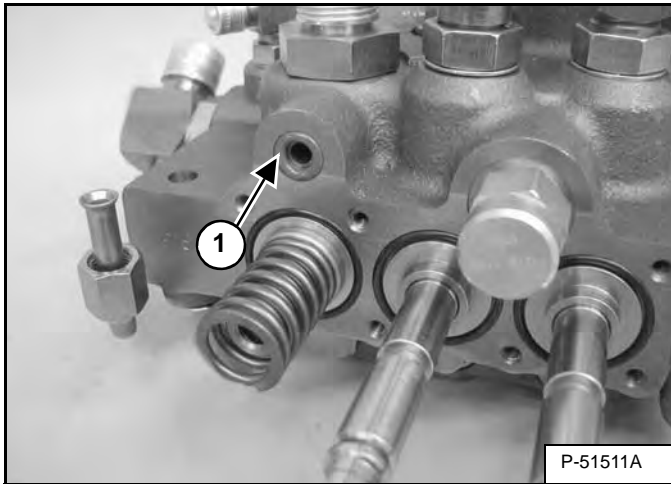

Remove the O-ring (Item 1) [Figure 20-40-44].

Installation: Replace the O-ring, and lubricate the O-ring lightly with grease or oil before installation of the end cap/spool lock block.

Figure 20-40-45

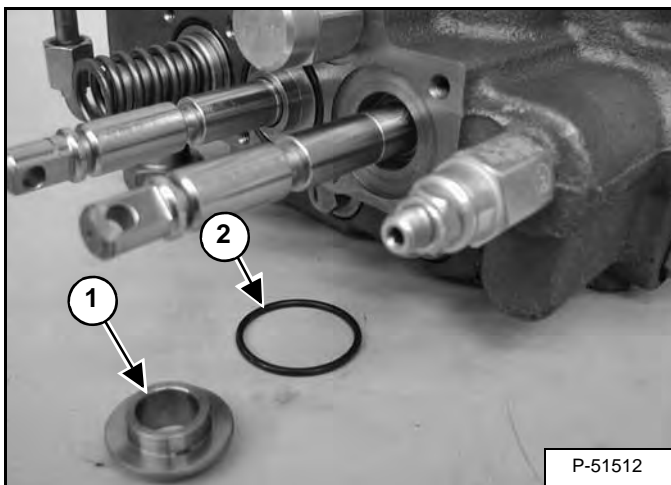

Remove the spacer (Item 1) and O-ring (Item 2) [Figure 20-40-45] from the lift spool.

Figure 20-40-46

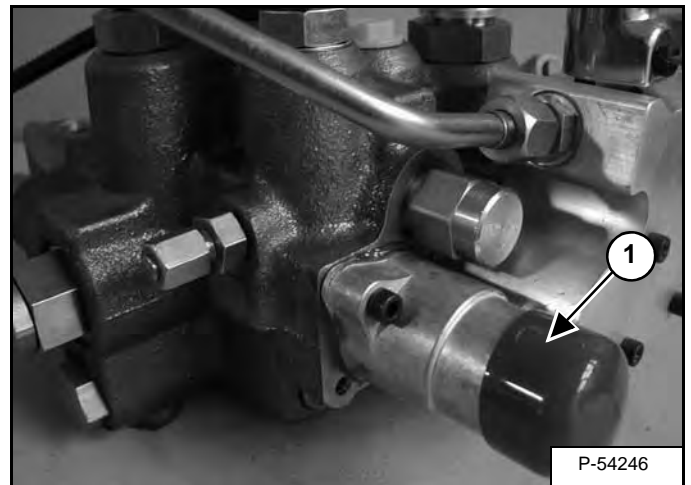

Remove the end cap (Item 1) [Figure 20-40-46].

Figure 20-40-47

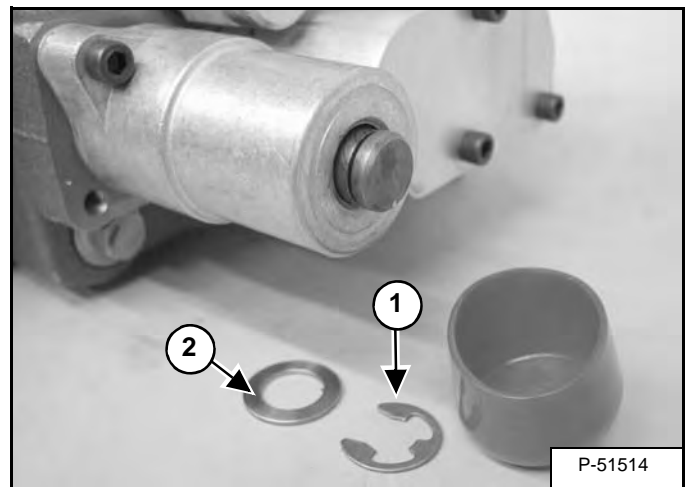

Use a screwdriver to remove the snap ring (Item 1) [Figure 20-40-47].

Remove the washer (Item 2) [Figure 20-40-47].

HYDRAULIC CONTROL VALVE (STANDARD) (CONT'D)

Tilt Spool Removal And Installation

Remove the lift and tilt end cap/spool lock block. (See End Cap Block Removal And Installation on Page 20-40-14.)

Figure 20-40-82

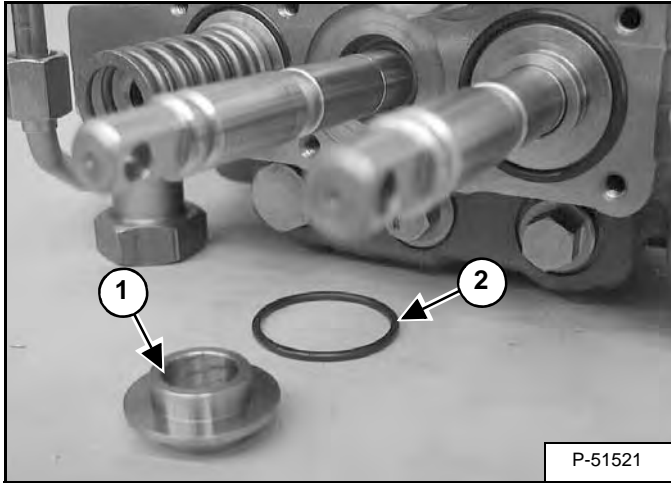

Remove the spacer (Item 1) and O-ring (Item 2) [Figure 20-40-82] from the tilt spool.

Figure 20-40-83

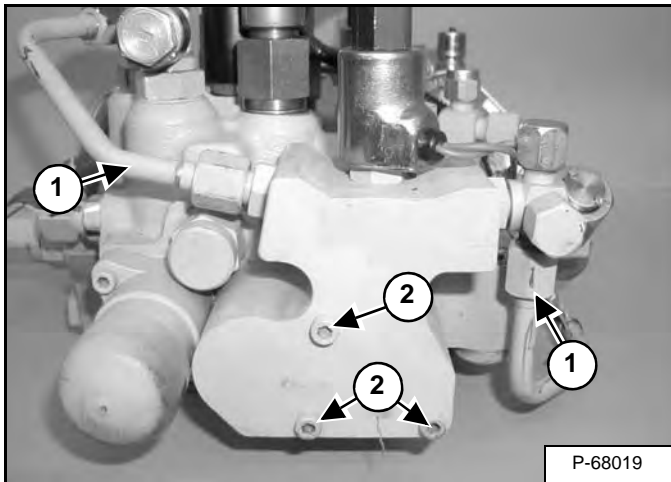

Disconnect the two tubelines (Item 1) [Figure 20-40-83] from the spool centering block.

Remove the three screws (Item 2) [Figure 20-40-83] from the spool centering block.

Installation: Tighten the bolt to 90 - 100 in.-lb. (10 - 11,3 N•m) torque.

Figure 20-40-84

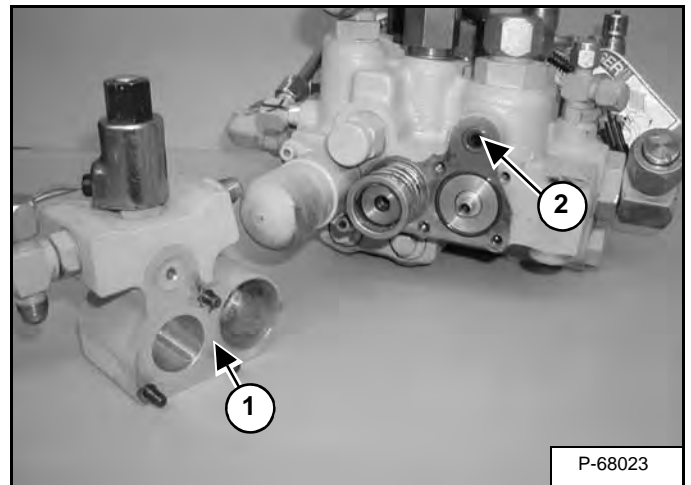

Remove the spool centering block (Item 1) [Figure 20-40-84] from the control valve.

Installation: Replace the O-ring (Item 2) [Figure 20-40-84] and lubricate the O-ring lightly with grease or oil before installation of the end cap/spool lock block.

Figure 20-40-85

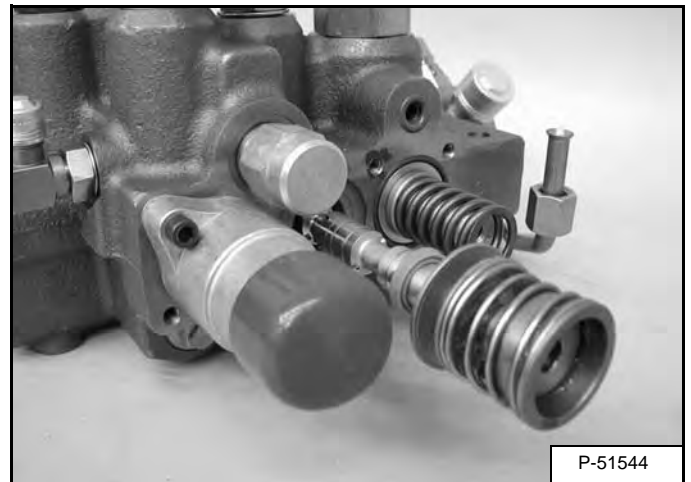

Remove the tilt spool, centering spring, back-up washer and spool seal [Figure 20-40-85].

Assembly: Always use a new spool seal.

HYDRAULIC CONTROL VALVE (ACS) OR (SJC)

Description

Figure 20-41-1

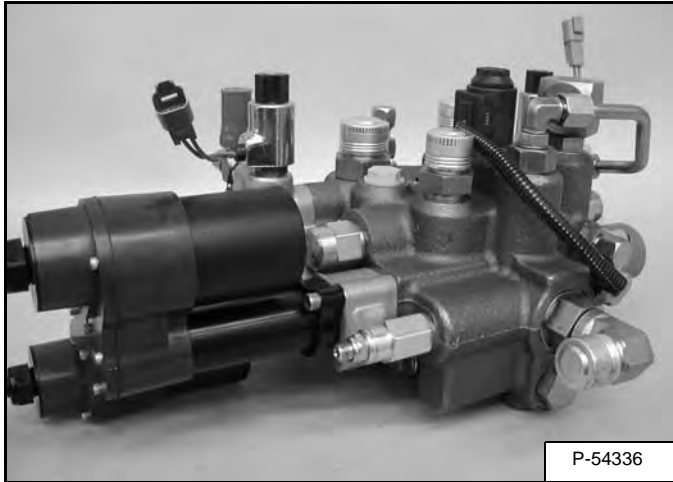

The hydraulic control valve is located inside the main frame on the right hand side, below the operators cab.

The hydraulic control valve **[Figure 20-41-1]** is the hydraulic component that uses spools to direct the flow of hydraulic fluid to the lift, tilt and auxiliary functions.

The lift and tilt functions in the ACS or the SJC hydraulic control valve are operated using electronic control handle/levers or foot pedals that send an electronic signal to the electronic actuators to move the lift and tilt spools in the control valve.

The auxiliary function is operated by pilot pressure. There is one solenoid located by each side of the spool. Only one solenoid at a time is activated by the switch on the right side control handle/lever. The activated solenoid sends pilot pressure oil to one side of the spool and forces the spool to shift.

The hydraulic control valve also contains a main relief valve which is adjustable.

**HYDRAULIC CONTROL VALVE (ACS) OR (SJC)
(CONT'D)**

Identification Chart

Figure 20-41-27

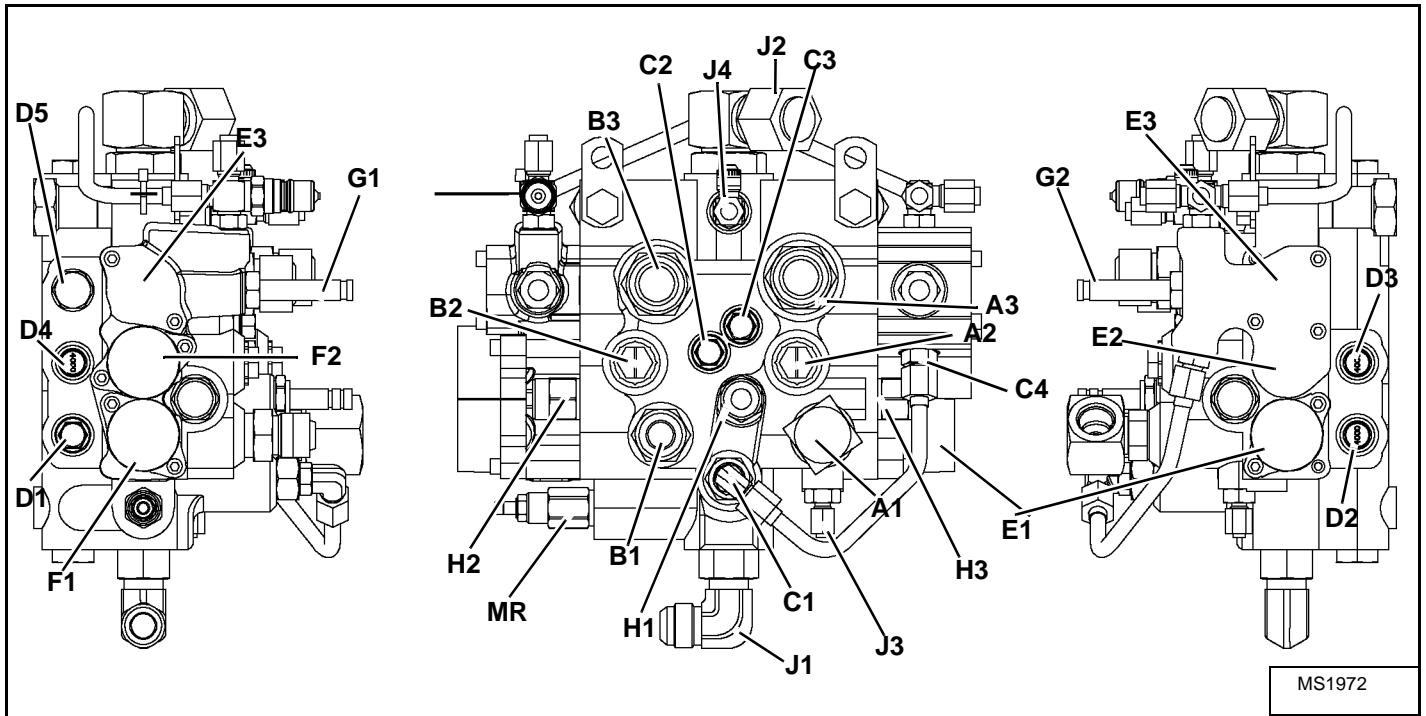

ITEM	S330 LOADER
A1	Lift Cylinder Base End
A2	Tilt Cylinder Base End
A3	Auxiliary Hydraulic Rod End
B1	Lift Cylinder Rod End
B2	Tilt Cylinder Rod End
B3	Auxiliary Hydraulics Base End
C1	Lift Load Check
C2	Load Check Valve Tilt Function
C3	Load Check Valve Auxiliary Function
C4	Check Valve
D1	Anti-Cavitation Valve Lift (Rod End)
D2	Port Relief/Anti-Cavitation Valve – 4000 PSI Lift (Base End)
D3	Port Relief/Anti-Cavitation Valve – 4000 PSI Tilt (Base End)
D4	Port Relief/Anti-Cavitation Valve – 4000 PSI Tilt (Rod End)
D5	Port Relief/Anti-Cavitation Valve (Auxiliary) 3500 PSI (Optional)

ITEM	S330 LOADER
E1	Lift Spool Centering Spring
E2	Tilt Spool Centering Spring
E3	Auxiliary Spool/Centering Springs
F1	Lift Spool
F2	Tilt Spool
G1	Auxiliary Solenoid Stem
G2	Auxiliary Solenoid Stem
H1	BICS Valve Solenoid
H2	BICS Lock Valve (Tilt)
H3	BICS Lock Valve (Lift)
J1	Inlet Fluid Flow (From Pump)
J2	Outlet Fluid Flow (Return to Tank)
J3	Lift Arm Bypass Orifice
J4	Drain (Case)
MR	Main Relief Valve – 3300 PSI

HYDRAULIC CONTROL VALVE (ACS) OR (SJC) (CONT'D)

Lift Spool And Detent Removal And Installation (Cont'd)

Figure 20-41-61

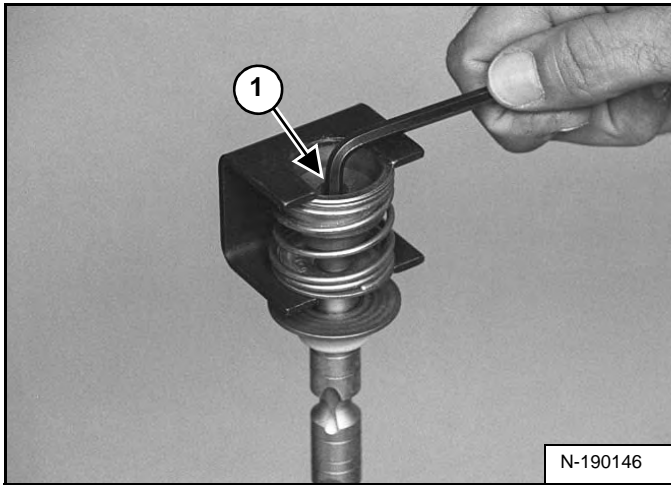

Remove the bolt (Item 1) [Figure 20-41-61] holding the centering spring to the spool.

Installation: Tighten the bolt to 90 - 100 in.-lb. (10,2 - 11,3 N•m) torque.

Remove spring tool from the spring assembly.

Figure 20-41-62

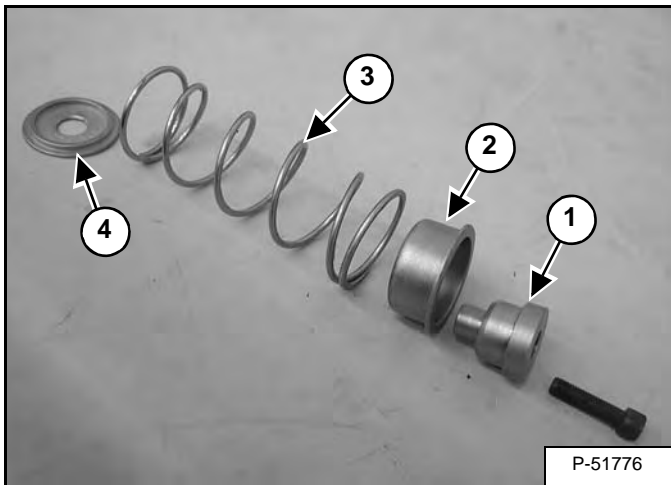

Inspect the adapter (Item 1), collar (Item 2), spring (Item 3) and washer (Item 4) [Figure 20-41-62].

Figure 20-41-63

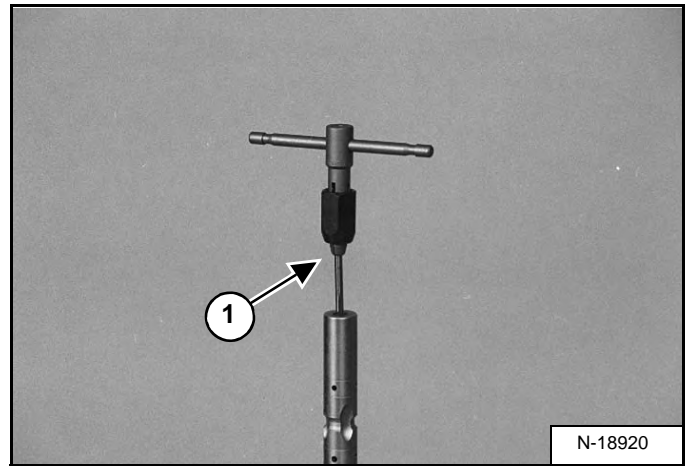

Removal of the plastic plug:

Make a center point in the plug using a 1/16 in. drill.

Drill a hole all the way through the plug using a 7/64 in. tap drill

Turn a 6-32 tap (Item 1) [Figure 20-41-63] into the plug. Pull the tap and plug out of the spool. Be careful, do not break the tap.

Clean all the debris from inside the spool bore.

NOTE: DO NOT USE LOCTITE® ON THE STUD THREADS.

Figure 20-41-64

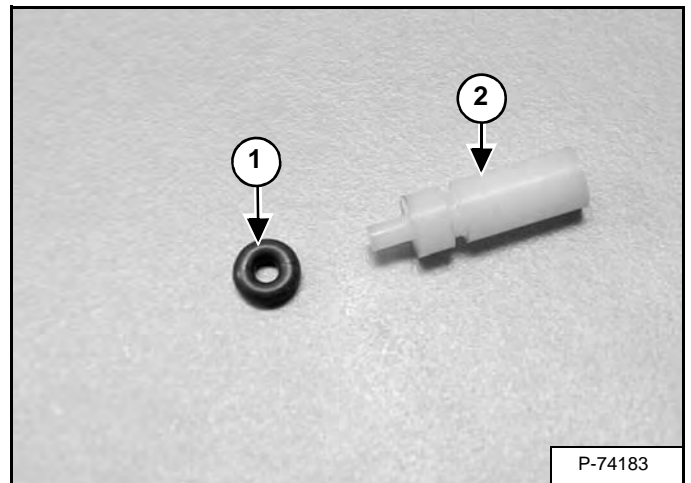

Install the O-ring (Item 1) over the nipple on the plastic plug (Item 2) [Figure 20-41-64].

NOTE: Check the O-ring for damage. The lift spool will have an internal leak if there is damage to this O-ring. Always replace the O-ring and recheck the lift spool before the control valve is replaced.

HYDRAULIC CONTROL VALVE (ACS) OR (SJC)
(CONT'D)

Lock Valve Removal And Installation (Cont'd)

Figure 20-41-98

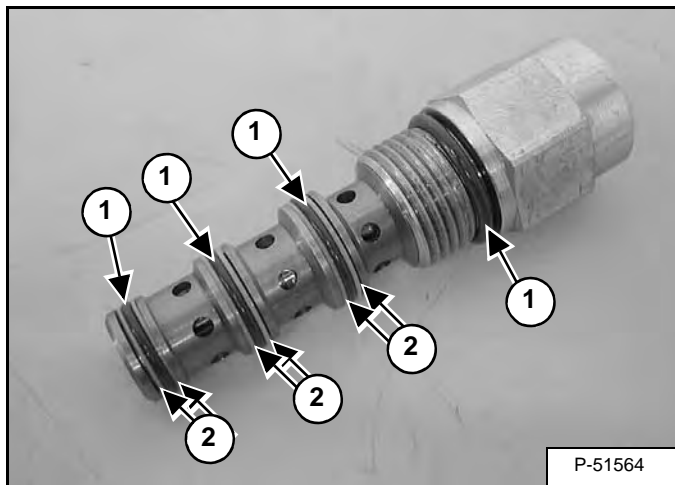

Remove the O-rings (Item 1) and back-up rings (Item 2) [Figure 20-41-98] from the tilt lock valve, and replace with new.

HYDRAULIC PUMP (STANDARD) (CONT'D)

Direct Pump Test (Standard Section)

The tools listed will be needed to do the following procedure:

MEL1563 or 6689779 - Remote Start Tool
MEL10103 - Hydraulic Tester
MEL10106 - Hydraulic Test Kit

WARNING

Put jackstands under the front axles and rear corners of the frame before running the engine for service. Failure to use jackstands can allow the machine to fall or move and cause injury or death.

W-2017-0286

Lift and block the loader. (See Procedure on Page 10-10-1.)

Raise the lift arms and install an approved lift arm support device. (See Installing on Page 10-20-1.)

WARNING

Never work on a machine with the lift arms up unless the lift arms are secured by an approved lift arm support device. Failure to use an approved lift arm support device can allow the lift arms or attachment to fall and cause injury or death.

W-2059-0598

Raise the operator cab. (See Raising on Page 10-30-1.)

Open the rear door of the loader.

Connect the remote start tool. (See REMOTE START TOOL KIT-MEL1563 on Page 10-60-1.)

Figure 20-60-2

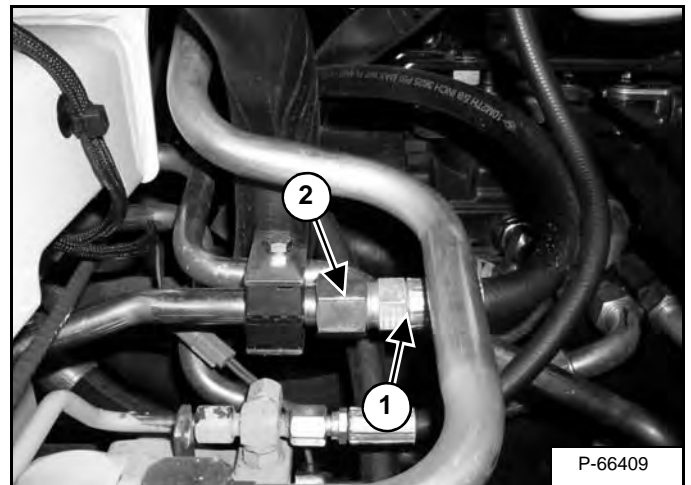

Disconnect the OUTLET hose (Item 1) [Figure 20-60-2] that comes from the gear pump, and connects to the tubeline on the control valve.

Figure 20-60-3

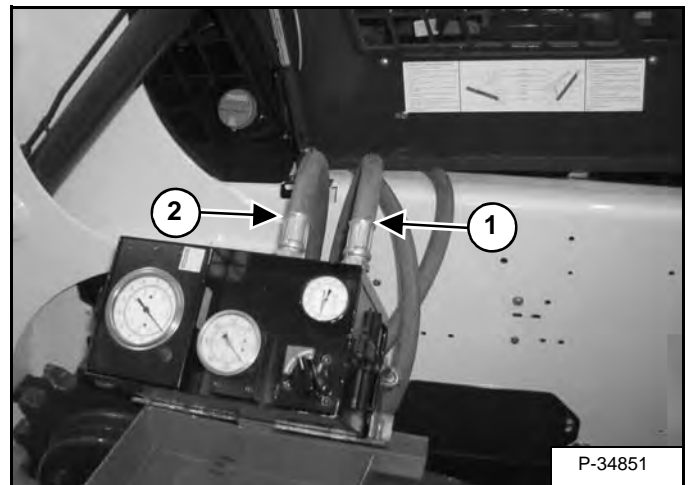

Connect the INLET hose (Item 1) [Figure 20-60-3] from the tester to the OUTLET hose (Item 1) [Figure 20-60-2] of the pump. Connect the OUTLET hose (Item 2) [Figure 20-60-3] from the tester to the tubeline (Item 2) [Figure 20-60-2] on the control valve.

IMPORTANT

The hydraulic tester must be in the fully open position before you start the engine.

I-2024-0284

HYDRAULIC PUMP (STANDARD) (CONT'D)

Parts Identification (Cont'd)

The items listed below refer to Page 20-60-12 [Figure 20-60-23].

1. Auxiliary Pump End Section
2. Section Seal
3. Pre-Load Seal
4. Load Seal
5. Wear Plate
6. Alignment Pins
7. Drive Gear (Auxiliary Pump)
8. Idler Gear (Auxiliary Pump)
9. Auxiliary Pump Center Section
10. Auxiliary Pump End Section
11. Spline Shaft
12. Drive Gear (Charge Pump)
13. Idler Gear (Charge Pump)
14. Charge Pump Center Section
15. Charge Pump End Section
16. Shaft Seal
17. Bolts (4)
18. Bolts (4)

Disassembly And Assembly

IMPORTANT

When repairing hydrostatic and hydraulic systems, clean the work area before disassembly and keep all parts clean. Always use caps and plugs on hoses, tubelines and ports to keep dirt out. Dirt can quickly damage the system.

I-2003-0888

Mark the pump sections for correct assembly.

To disassemble and assemble the hydraulic pump, follow the Parts Identification page [Figure 20-60-23] for proper placement of components along with the information below.

NOTE: A seal kit is available through Bobcat Service Parts.

Assembly: Tighten the eight pump housing bolts (Item 19) [Figure 20-60-23] to 37 ft.-lb. (50 N•m) torque.

NOTE: Position the wear plate (Item 5) and (Item 10) [Figure 20-60-23] inlets and traps as shown with the bronze side toward the gears on all wear plates.

NOTE: Inspect all gears, shafts and pump end sections. If any of these components have excessive wear or damage is visible, the complete pump must be replaced.

HYDRAULIC PUMP (STANDARD) (HIGH FLOW) (CONT'D)

Direct Pump Test (High Flow Section)

The tools listed will be needed to do the following procedure:

MEL10103 - Hydraulic Tester
MEL10106 - Hydraulic Test Kit

WARNING

Put jackstands under the front axles and rear corners of the frame before running the engine for service. Failure to use jackstands can allow the machine to fall or move and cause injury or death.

W-2017-0286

Lift and block the loader. (See Procedure on Page 10-10-1.)

Figure 20-61-39

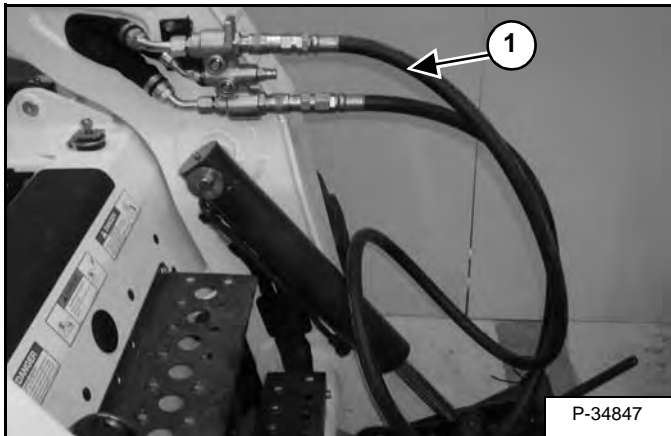

Install a jumper hose (Item 1) [Figure 20-61-39] onto the front auxiliary quick couplers.

Raise the lift arms and install an approved lift arm support device. (See Installing on Page 10-20-1.)

WARNING

Never work on a machine with the lift arms up unless the lift arms are secured by an approved lift arm support device. Failure to use an approved lift arm support device can allow the lift arms or attachment to fall and cause injury or death.

W-2059-0598

Raise the operator cab. (See Raising on Page 10-30-1.)

Figure 20-61-40

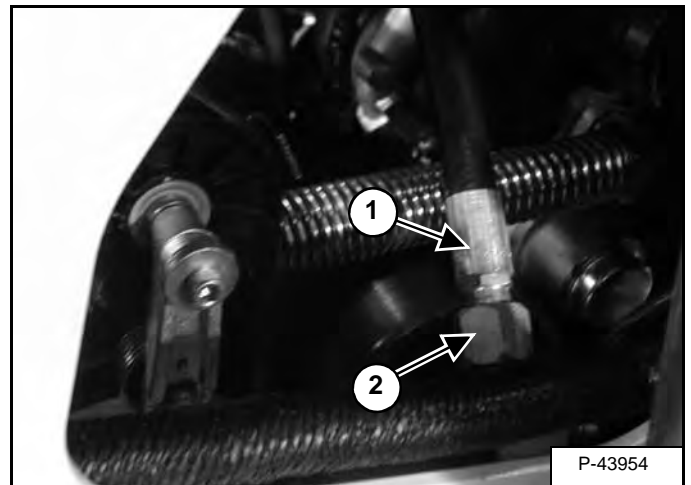

Remove the left side access cover.

Disconnect the high flow pump OUTLET hose (Item 1) from the fitting (Item 2) [Figure 20-61-40] on the tube line.

Figure 20-61-41

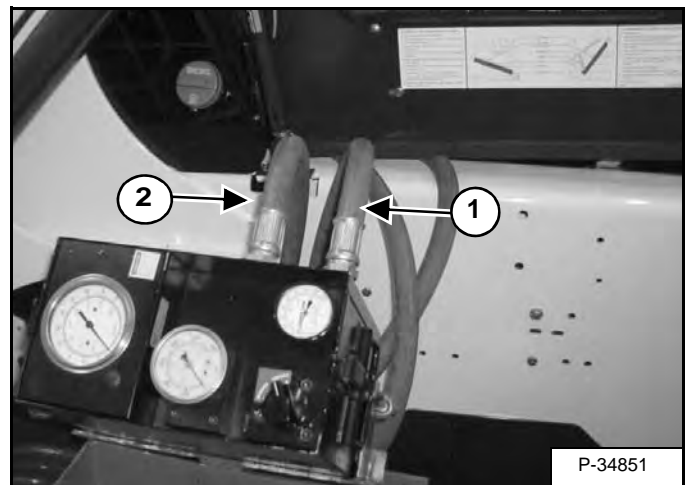

NOTE: When testing the hydraulic flow of a machine hoses must be at least 3/4 inch in diameter and connected directly to the hydraulic tester without using any type of “quick coupler” on the connection to the tester. Also make sure your hydraulic tester is capable of at least 50 GPM.

Connect the INLET hose (Item 1) [Figure 20-61-41] from the tester to the OUTLET hose (Item 1) [Figure 20-61-40] of the pump. Connect the OUTLET hose (Item 2) [Figure 20-61-41] from the tester to the fitting (Item 2) [Figure 20-61-40] on the tube line.

Lower the cab down.



Bobcat®

HYDRAULIC PUMP (SJC) (CONT'D)

Direct Pump Test (Charge Section) (Cont'd)

Figure 20-70-74

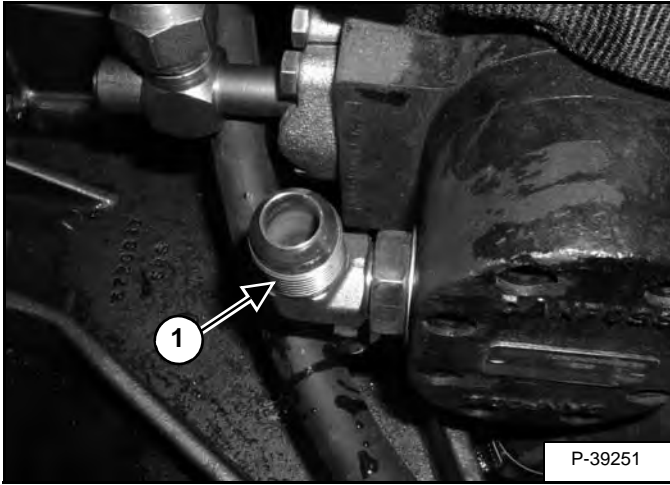

Install the elbow fitting 17KB 1212 (Item 1) [Figure 20-70-74] into the OUTLET of the charge pump.

Figure 20-70-75

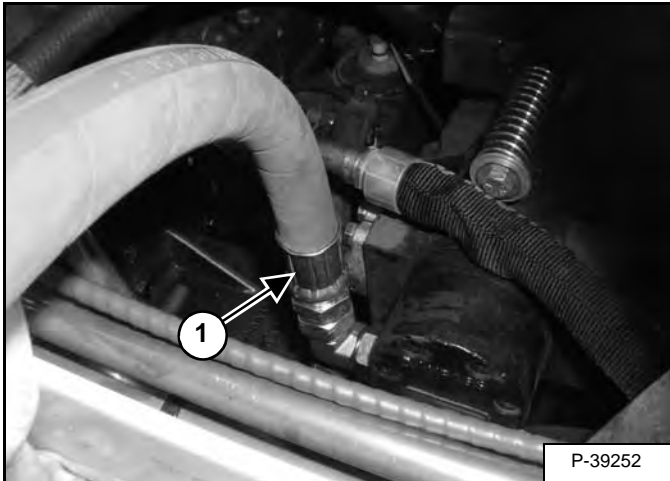

Connect the Inlet hose from the hydraulic tester (Item 1) [Figure 20-70-75] to the OUTLET fitting of the charge pump.

Figure 20-70-76

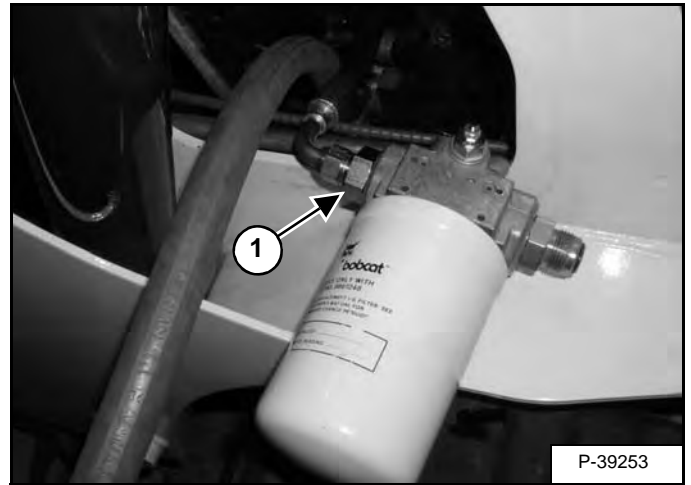

Connect the outlet fitting on the hydraulic filter (Item 1) [Figure 20-70-76] to the hose that was removed from the charge pump and routes to the back side of the hydrostatic pump.

Figure 20-70-77

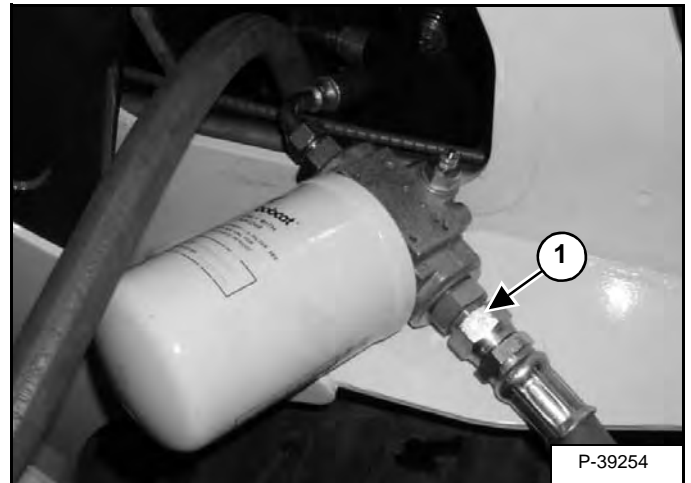

Connect the outlet hose on the hydraulic tester (Item 1) [Figure 20-70-77] to the inlet fitting on the hydraulic filter assembly.

HYDRAULIC PUMP (SJC) (HIGH FLOW) (CONT'D)

Direct Pump Test (Standard Section)

The tools listed will be needed to do the following procedure:

MEL10103 - Hydraulic Tester
MEL10106 - Hydraulic Test Kit

WARNING

Put jackstands under the front axles and rear corners of the frame before running the engine for service. Failure to use jackstands can allow the machine to fall or move and cause injury or death.

W-2017-0286

Lift and block the loader. (See Procedure on Page 10-10-1.)

Raise the lift arms and install an approved lift arm support device. (See Installing on Page 10-20-1.)

WARNING

Never work on a machine with the lift arms up unless the lift arms are secured by an approved lift arm support device. Failure to use an approved lift arm support device can allow the lift arms or attachment to fall and cause injury or death.

W-2059-0598

Raise the operator cab. (See Raising on Page 10-30-1.)

Figure 20-71-88

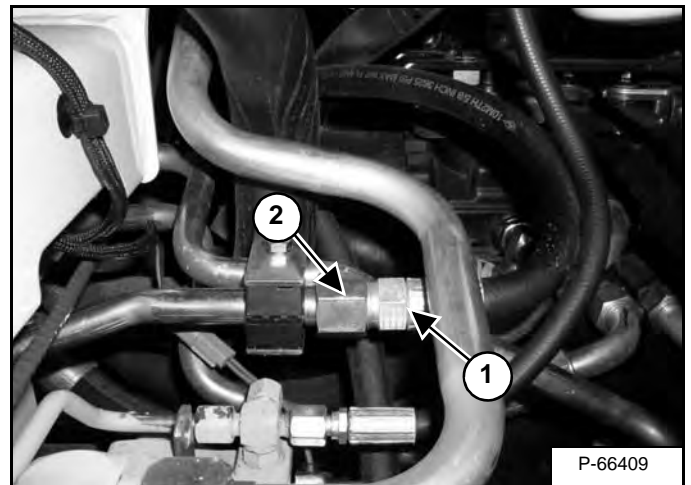

At the control valve, disconnect the standard (auxiliary) pump OUTLET hose (Item 1) [Figure 20-71-88] from the tubeline.

Figure 20-71-89

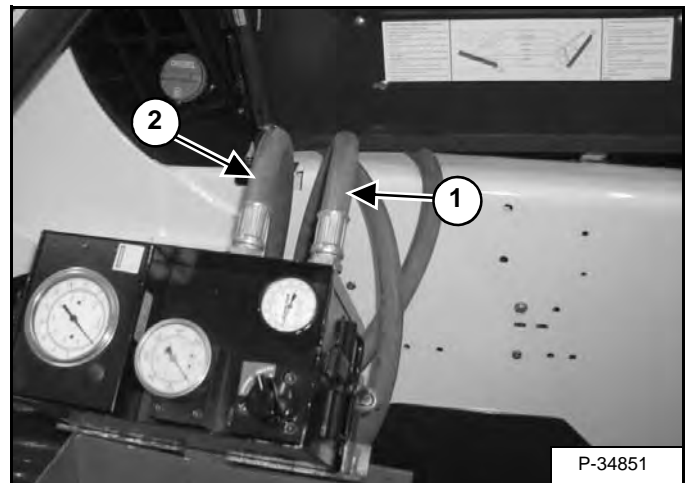

NOTE: When testing the hydraulic flow of a machine hoses must be at least 3/4 inch in diameter and connected directly to the hydraulic tester without using any type of “quick coupler” on the connection to the tester. Also make sure your hydraulic tester is capable of at least 50 GPM.

Connect the INLET hose (Item 1) [Figure 20-71-89] from the tester to the OUTLET hose (Item 1) [Figure 20-71-88] of the pump. Connect the OUTLET hose (Item 2) [Figure 20-71-89] from the tester to the tubeline (Item 2) [Figure 20-71-88] which goes to the control valve.

Lower the cab down.

HYDRAULIC PUMP (SJC) (HIGH FLOW) (CONT'D)

High Flow Relief Valve Adjustment (Cont'd)

Figure 20-71-111

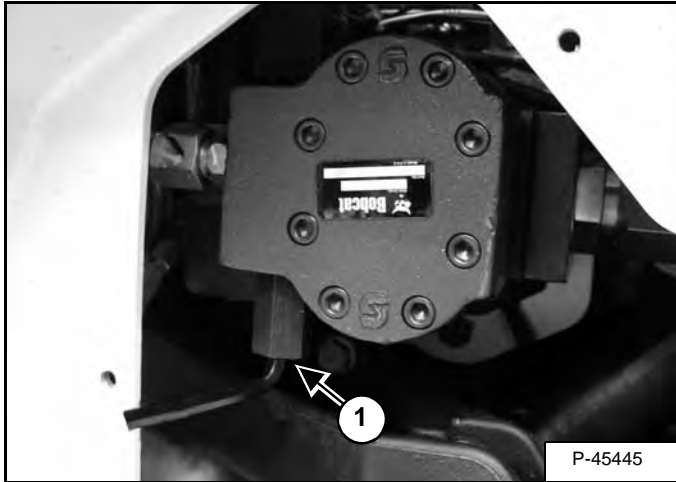

Start the engine and run at low idle RPM. Press the Front Auxiliary button. Press the High Flow button. Engage the front auxiliary with the trigger on the right handle. Make sure the tester is connected correctly. If no flow is indicated on the tester, the hoses are connected wrong. With the hoses connected correctly, increase the engine speed to full RPM*.

Warm the fluid to 140°F. (60°C.) by turning the restrictor control clockwise on the tester to about 1000 PSI (69 bar).

NOTE: DO NOT EXCEED 3300 PSI.

Turn the restrictor control clockwise on the tester to causing more restriction on the flow. The GPM should drop off slightly until the pressure reaches approximately 3100 PSI. At approximately 3100 PSI the flow should start decreasing rapidly until the pressure reaches 3250-3350 PSI. At 3250-3350 PSI the flow should be at 0 GPM. Turn the restrictor counterclockwise to free flow. Shut the front auxiliary hydraulics off.

If the specs from above are reached, the pump is OK.

If the pump is unable to reach 3300 PSI stop the engine. The relief screw (Item 1) [Figure 20-71-111] will need to be turned clockwise a 1/4 turn and retested with the procedure above. (1/4 turn equals approximately 200 PSI.)

NOTE: If the relief screw has been turned in 1/4 turn and the pressure remains the same, go to the high flow relief valve removal and installation section. (See High Flow Relief Valve Removal And Installation on Page 20-71-14.) If relief valve has been checked and is OK, go to the high flow pump disassembly and assembly section. (See Disassembly And Assembly on Page 20-71-21.)

If the pump reaches 3300 PSI and there is flow stop the engine. The relief screw must be turned counterclockwise 1/4 turn and retested with the procedure above.

HYDRAULIC/HYDROSTATIC FILTERS

Description

The hydraulic/hydrostatic filters help to remove contaminants from the fluid when the hydraulic/hydrostatic systems are operating.

The hydraulic/hydrostatic filter system consists of one main filter and one charge pressure filter.

The main filter removes contaminants after the oil cooler.

The charge pressure filter removes contaminants after the charge pump.

Housing Removal And Installation

 DANGER	
AVOID DEATH <ul style="list-style-type: none">• Disconnecting or loosening any hydraulic tubeline, hose, fitting, component or a part failure can cause lift arms to drop.• Keep out of this area when lift arms are raised unless supported by an approved lift arm support. Replace if damaged. <small>67116 SW 6717343A enUS</small>	



Never work on a machine with the lift arms up unless the lift arms are secured by an approved lift arm support device. Failure to use an approved lift arm support device can allow the lift arms or attachment to fall and cause injury or death.

W-2059-0598

Figure 20-80-1

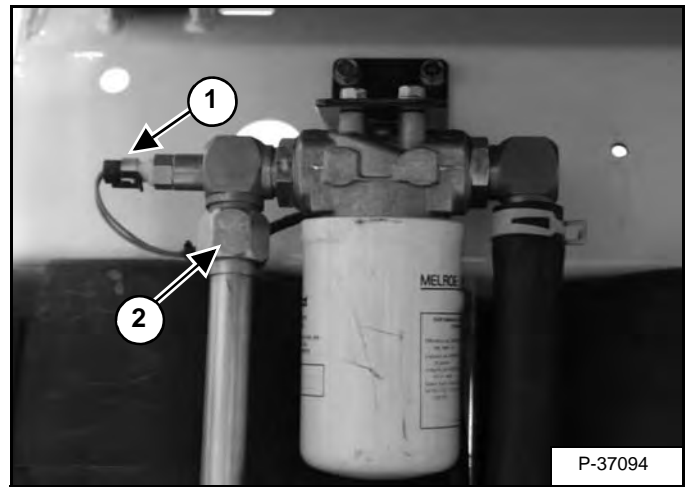

Raise the lift arms and install an approved lift arm support device. (See Installing on Page 10-20-1.)

Raise the operator cab. (See Raising on Page 10-30-1.)

Disconnect the electrical connector (Item 1) [Figure 20-80-1] from the filter sender.

Loosen the nut (Item 2) [Figure 20-80-1] and disconnect the tubeline from the filter block.

BUCKET POSITION VALVE

Description

The Bucket Position Valve is an option that allows the loader to meter the lift and tilt circuits. The metering of the lift and tilt circuits allows the operator to hold the attachment at the same angle from the ground to maximum lift height without using the tilt function.

The bucket position valve is located below the operators cab on the right side of the hydraulic fluid reservoir.

See Hydraulic Schematic for more circuit information.

REAR AUXILIARY DIVERTER VALVE (CONT'D)

Disassembly And Assembly (Cont'd)

Figure 20-120-20

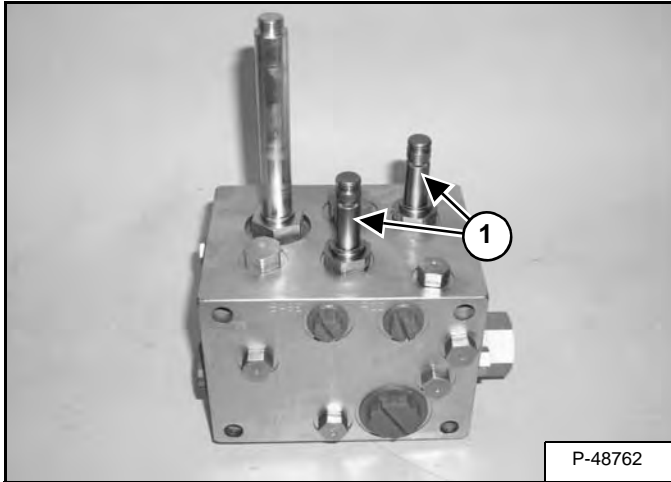
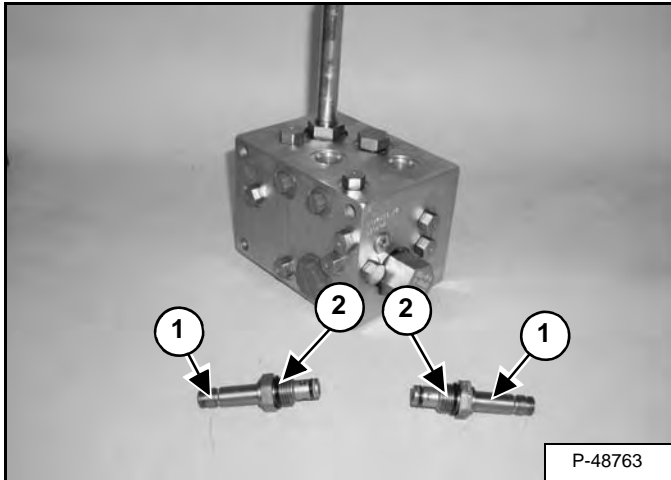

Figure 20-120-21



Remove the solenoid valve stem (Item 1) [Figure 20-120-20] & [Figure 20-120-21] and inspect the O-rings and back-up washers (Item 2) [Figure 20-120-21] for damage.

Assembly: Put oil on O-rings and back-up washers. Tighten to 20 - 25 ft.-lb. (27 - 34 N•m) torque.

Figure 20-120-22

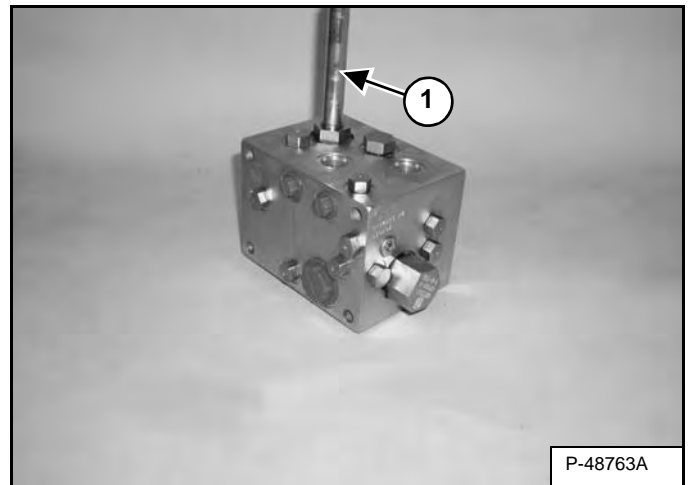
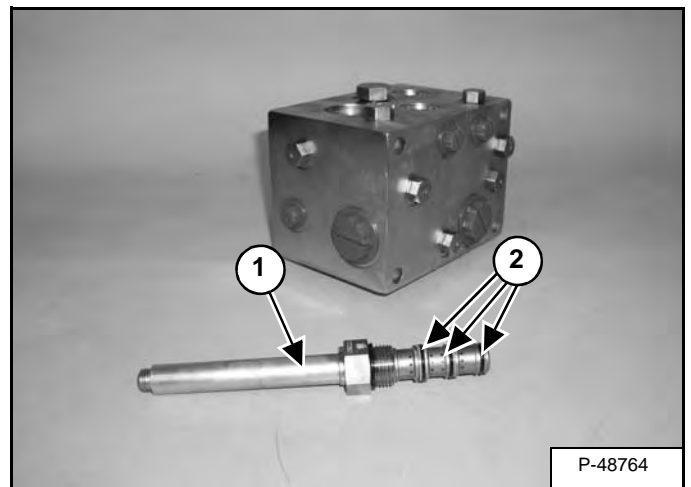

Figure 20-120-23



Remove the solenoid valve stem (Item 1) [Figure 20-120-22] & [Figure 20-120-23] and inspect the O-rings and back-up washers (Item 2) [Figure 20-120-23] for damage.

Assembly: Put oil on O-rings and back-up washers. Tighten to 30 - 35 ft.-lb. (41 - 47 N•m) torque.

FRONT AUXILIARY HYDRAULIC COUPLER BLOCK

Description

The front auxiliary hydraulic coupler block is the connection block that houses the two main auxiliary couplers along with a case drain coupler. These couplers are for supplying hydraulic flow for various attachments.

The front auxiliary coupler block is located at the front of the left side lift arm.

Removal And Installation

IMPORTANT

When repairing hydrostatic and hydraulic systems, clean the work area before disassembly and keep all parts clean. Always use caps and plugs on hoses, tubelines and ports to keep dirt out. Dirt can quickly damage the system.

I-2003-0888

Figure 20-140-1

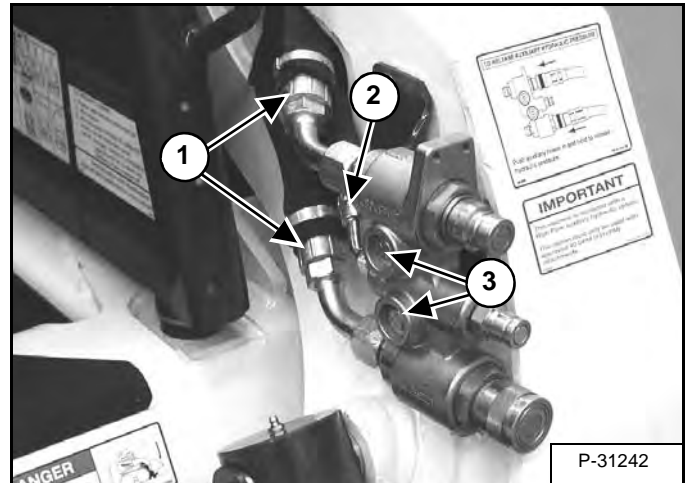

Disconnect the auxiliary hoses (Item 1) and drain hose (Item 2) [Figure 20-140-1] from the coupler block.

Remove the two mounting bolts (Item 3) [Figure 20-140-1].

HYDROSTATIC MOTOR (CONT'D)

Removal And Installation (Cont'd)

Figure 30-20-3

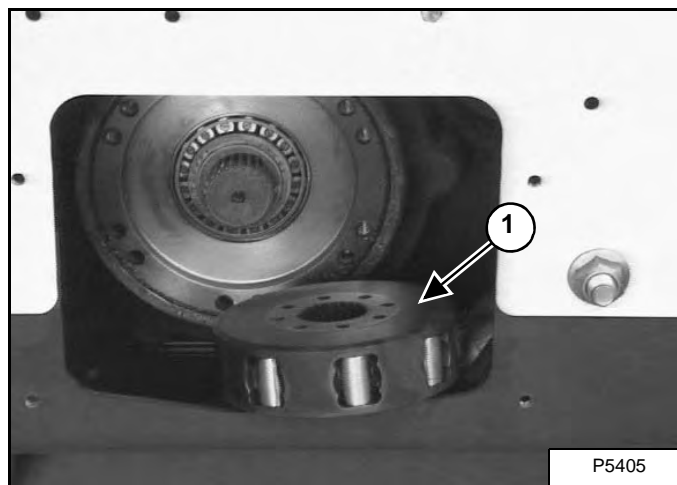

Remove the piston/roller section (Item 1) **[Figure 30-20-3]** from the loader, if it was not removed with the motor/cam ring.

To remove the motor carrier. (See Removal And Installation on Page 30-30-2.)

HYDROSTATIC MOTOR (TWO-SPEED) (CONT'D)

Disassembly

Figure 30-21-8

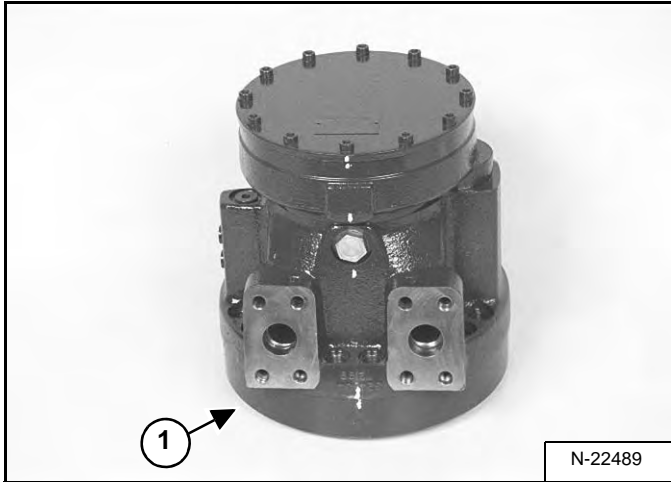

NOTE: Install a mark on the motor, brake, and motor carrier housings for correct assembly [Figure 30-21-8].

NOTE: Always protect any sealing surfaces. Any scratches or marks will cause premature failure.

Place the cam sealing surface (Item 1) [Figure 30-21-8] on a protective material.

Drain the oil from the motor casing.

Figure 30-21-9

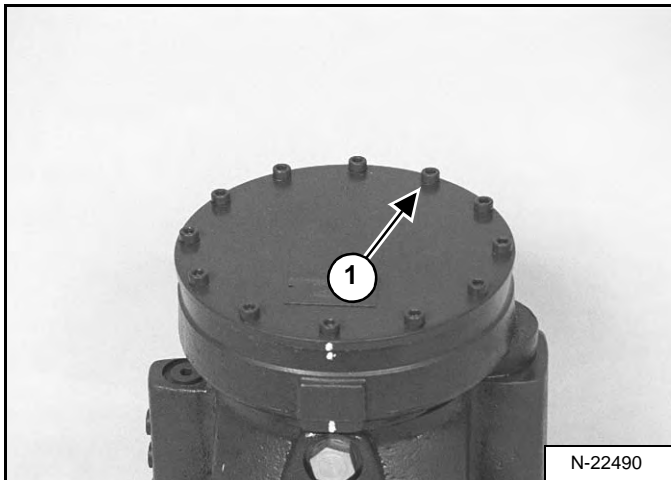

Remove the twelve mounting bolts (Item 1) [Figure 30-21-9] from the brake cover plate.

NOTE: Remove and/or tightened the bolts one turn at a time to maintain equal preload on the end cap and the brake spring.

Figure 30-21-10

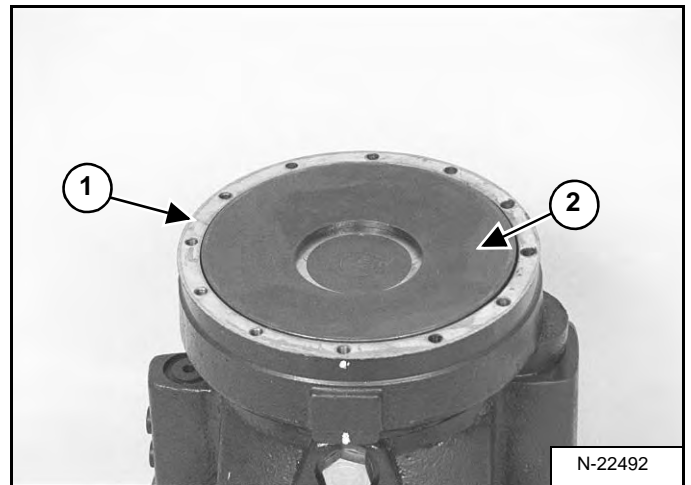

Remove the cover plate from the brake housing.

Remove the cover plate gasket (Item 1) [Figure 30-21-10].

Remove the brake spring (Item 2) [Figure 30-21-10] from the brake housing.

NOTE: Mark the top side of the brake spring for proper installation.

Figure 30-21-11

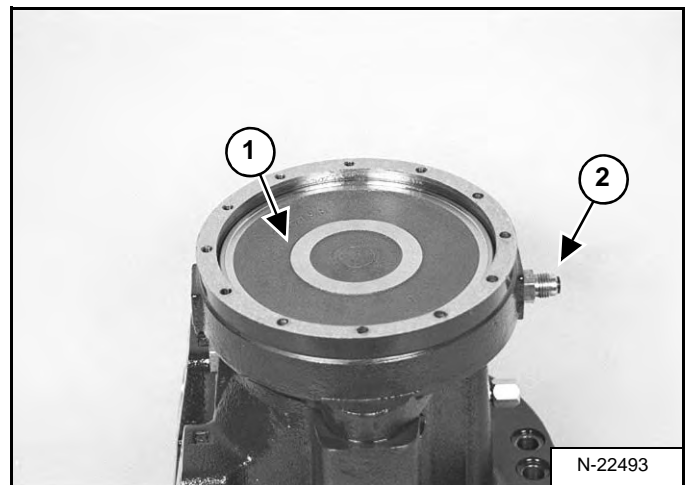

Remove the piston from the brake housing (Item 1) [Figure 30-21-11].

NOTE: The use of air pressure through the brake line connection (Item 2) [Figure 30-21-11] will aid in piston removal.

Check the brake piston for damage and replace the seal.

HYDROSTATIC MOTOR (TWO-SPEED) (CONT'D)

Assembly (Cont'd)

Figure 30-21-48

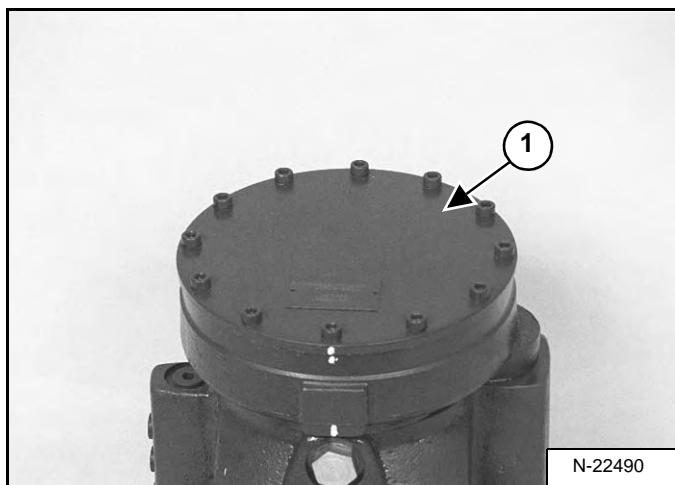

Install the brake end cover (Item 1) **[Figure 30-21-48]**.

Install the twelve end cover mount bolts and tighten evenly to 10 - 12 ft.-lb. (14 - 16 N•m) torque.

HYDROSTATIC MOTOR CARRIER (SJC) (CONT'D)

Parts Identification

Ref. Description

- 1. Snap Ring
- 2. Bearing
- 3. Race
- 4. Seal
- 5. Housing
- 6. Speed Washer
- 7. Shaft
- 8. Cover

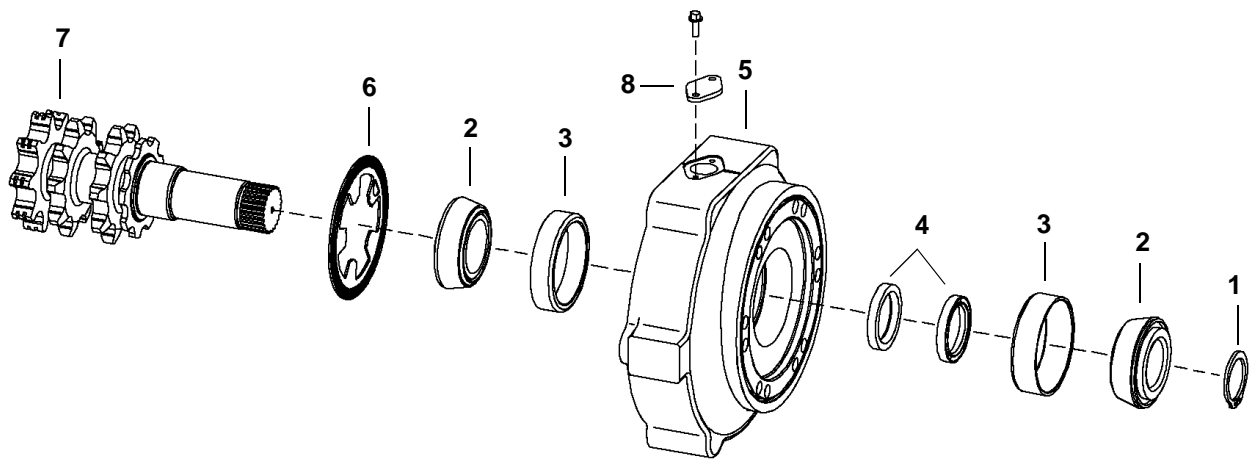

PE3328SA

CHARGE PRESSURE (CONT'D)

Adjusting

Non SJC Machines

IMPORTANT

When repairing hydrostatic and hydraulic systems, clean the work area before disassembly and keep all parts clean. Always use caps and plugs on hoses, tubelines and ports to keep dirt out. Dirt can quickly damage the system.

I-2003-0888

Figure 30-40-6

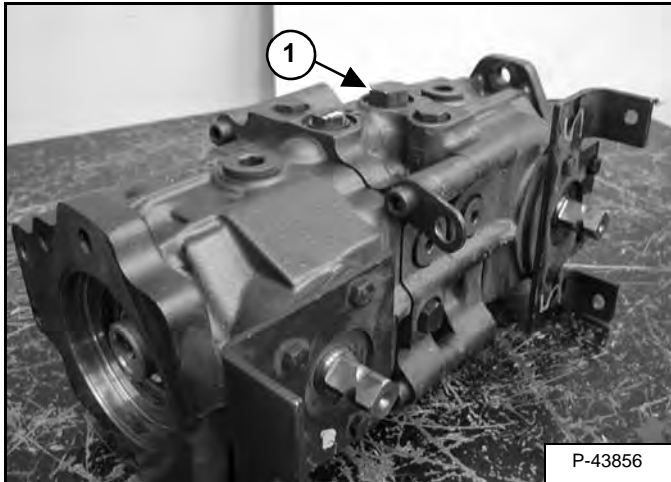

If the charge pressure is not correct loosen the charge relief valve plug (Item 1) [Figure 30-40-6].

Always use a new O-ring. Tighten the plug to 30 - 50 ft.-lb. (41 - 68 N•m) torque.

Figure 30-40-7

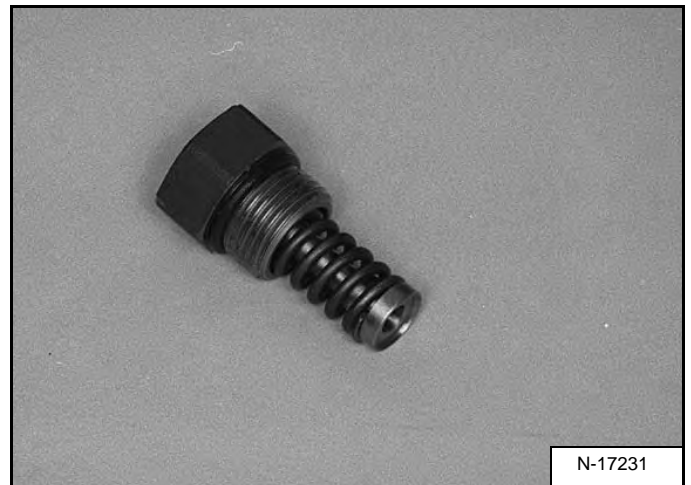

Remove the plug, spring and poppet [Figure 30-40-7].

Check the poppet, spring and poppet seat for wear or damage.

Figure 30-40-8

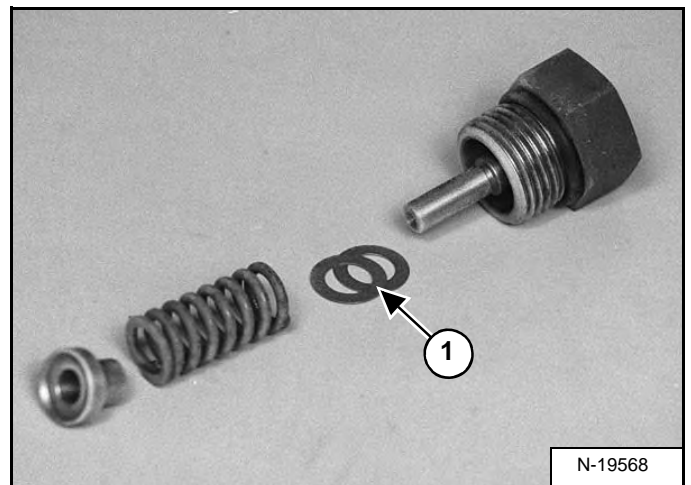

There are several different thickness of the shims (Item 1) [Figure 30-40-8] and are used to adjust the charge pressure.

NOTE: 0.010 inch (0,254 mm) is approximately 8 PSI (55.16 kPa) increase in pressure. Do not add more than 5 shims without retesting. If testing is still low more shims may be added.

On non-SJC equipped loaders the charge pressure at high idle, with the fluid temperature of 140°F (60°C) is **410 - 470 PSI (28,3 - 32,4 bar)** with the pump in neutral.

HYDROSTATIC PUMP (CONT'D)

Disassembly (Cont'd)

Figure 30-50-14

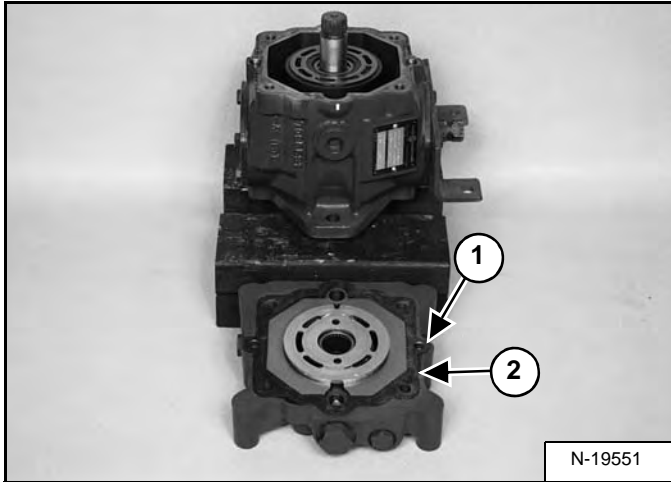

Remove the pump housing end cap (Item 1) [Figure 30-50-14].

Remove the gasket (Item 2) [Figure 30-50-14].

Figure 30-50-15

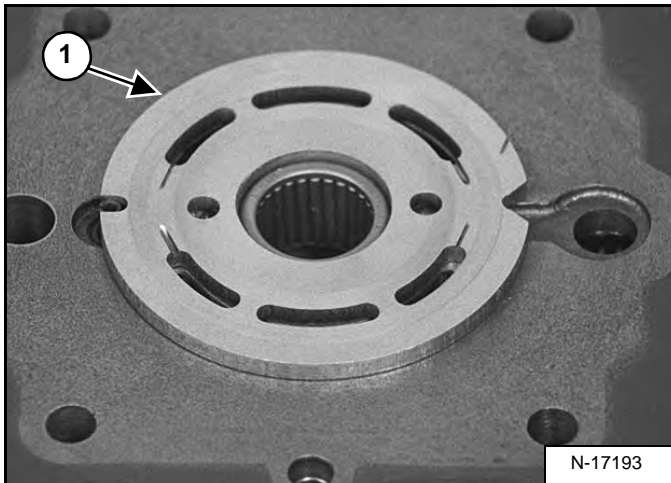

Remove the valve plate (Item 1) [Figure 30-50-15].

Check the valve plate for wear. (Both Sides.)

Figure 30-50-16

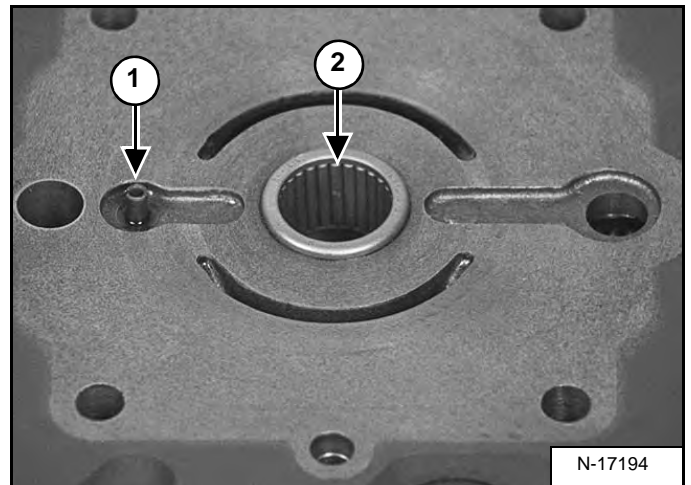

Check the valve plate locating pin (Item 1) [Figure 30-50-16] for wear and replace if needed.

Check the needle bearing (Item 2) [Figure 30-50-16] for wear and replace if needed.

Figure 30-50-17

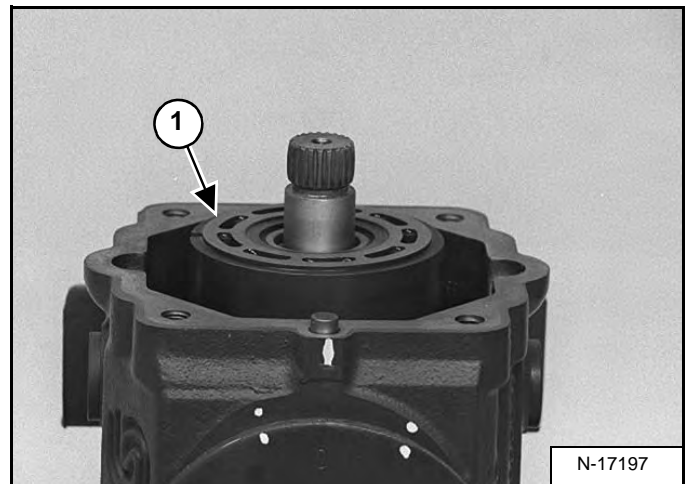

Remove the rotating group (Item 1) [Figure 30-50-17] from the pump.

HYDROSTATIC PUMP (CONT'D)

Assembly (Cont'd)

Figure 30-50-53

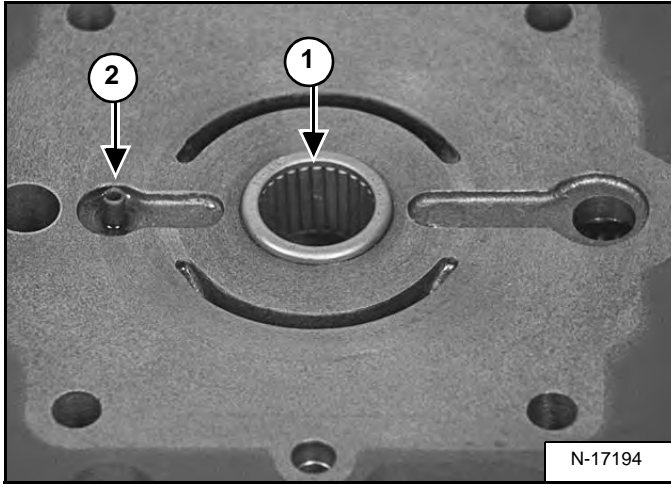

Replace the needle bearing (Item 1) and valve plate locating pin (Item 2) [Figure 30-50-53] in the charge pump.

Figure 30-50-54

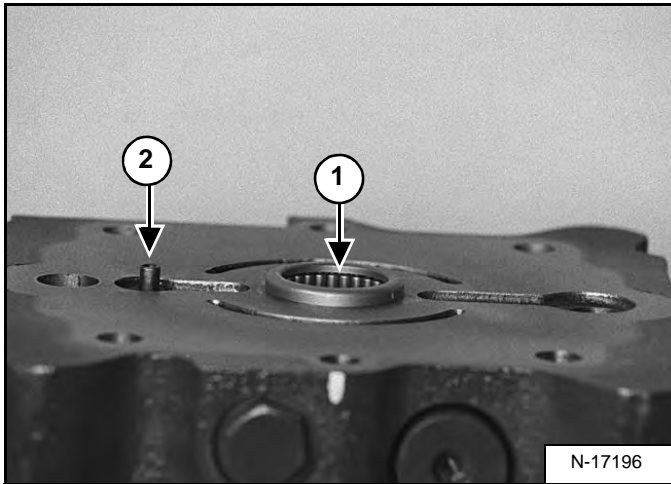

The bearing cage (Item 1) [Figure 30-50-54] will protrude from 0.08 - 0.10 in. (2,0 - 2,5 mm) from the surface of the charge pump.

The valve plate locating spring pin (Item 2) [Figure 30-50-54] will protrude from 0.165 - 0.185 in. (4,19 - 4,70 mm) from the surface of the charge pump.

Figure 30-50-55

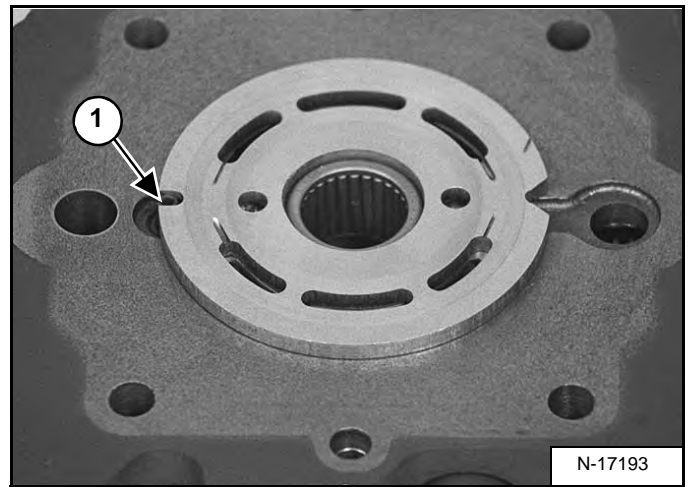

Coat the backside of the valve plate with petroleum jelly to hold it in position and install the valve plate onto the charge pump, bronze face up [Figure 30-50-55].

The notch (Item 1) [Figure 30-50-55] on the valve plate must engage the locating pin.

Figure 30-50-56

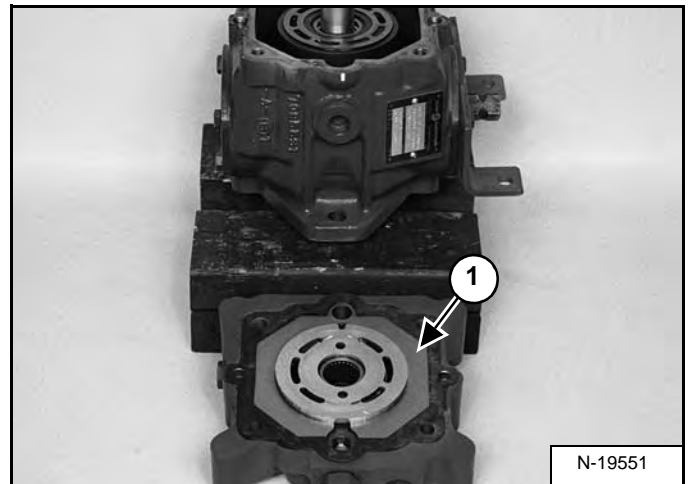

Coat a new end cap gasket (Item 1) [Figure 30-50-56] with petroleum jelly and install onto the end cap.

HYDROSTATIC PUMP (SJC) (CONT'D)

Charge Relief Valve

Figure 30-51-19

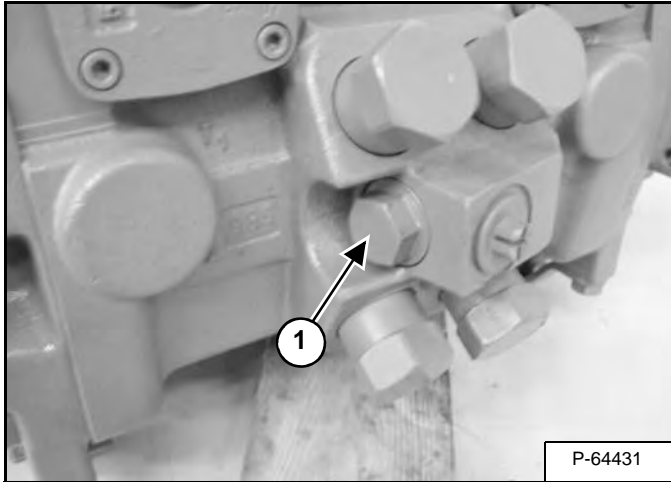

The charge relief valve (Item 1) [Figure 30-51-19] is located on the back of the hydrostatic pump.

Remove the charge relief valve.

Assembly: Tighten charge relief valve to 52 ft.-lb. (70 N•m) torque.

Figure 30-51-20

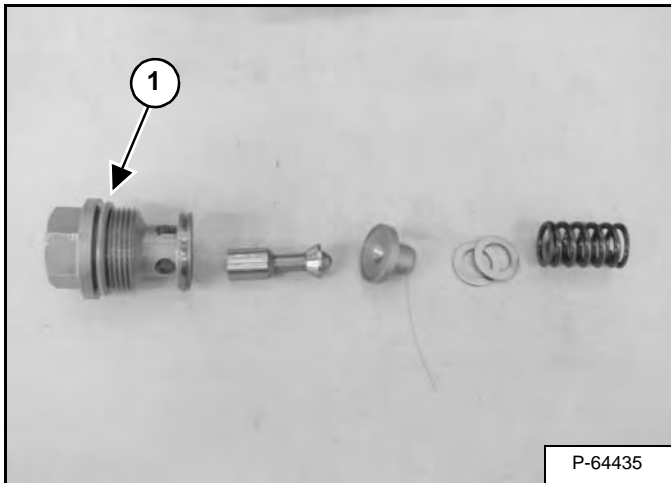

Check and replace the O-ring (Item 1) [Figure 30-51-20].

Figure 30-51-21

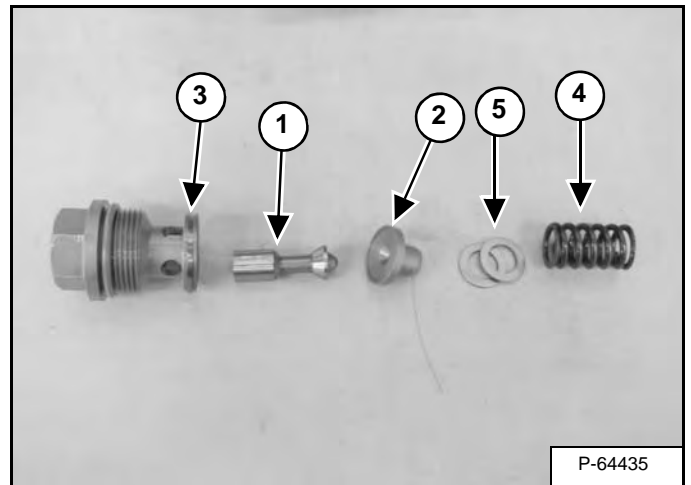

Inspect the poppet (Item 1) and the mating seat (Item 2) [Figure 30-51-21] for damage or foreign material. Ensure the poppet moves freely in its bore.

Inspect the sealing ring (Item 3) [Figure 30-51-21] and the mating seat in the pump housing for damage or foreign material.

Inspect the spring (Item 4) and the charge relief valve shims (Item 5) [Figure 30-51-21].

NOTE: 1,0 mm shim (Item 5) [Figure 30-51-21] = 43.5 PSI (3 bar) in pressure change. Adding shims increases charge pressure. Removing shims decreases charge pressure.

HYDROSTATIC PUMP (SJC) (CONT'D)

Disassembly And Assembly (Cont'd)

Figure 30-51-53

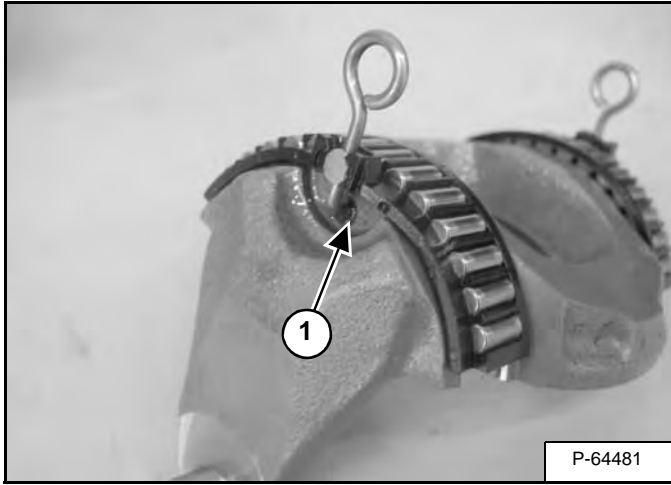

Assembly: Ensure bearing pins are in the holes of the swash plate (Item 1) [Figure 30-51-53].

Figure 30-51-54

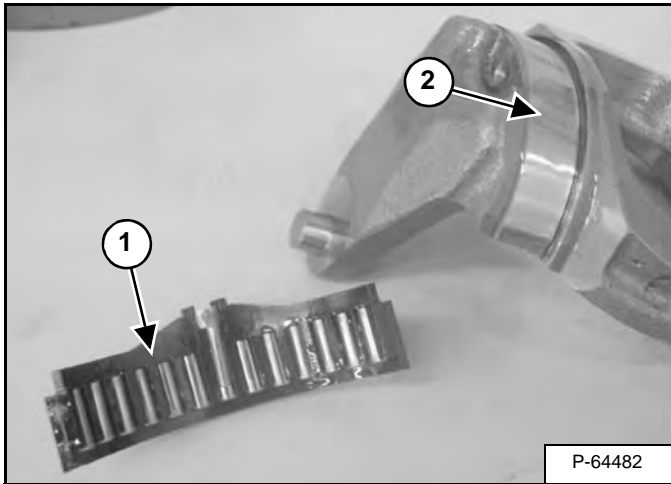

Remove the shell bearing (Item 1) [Figure 30-51-54].

Inspect individual roller bearings and machined surfaces (Item 2) [Figure 30-51-54] on swash plate.

Figure 30-51-55

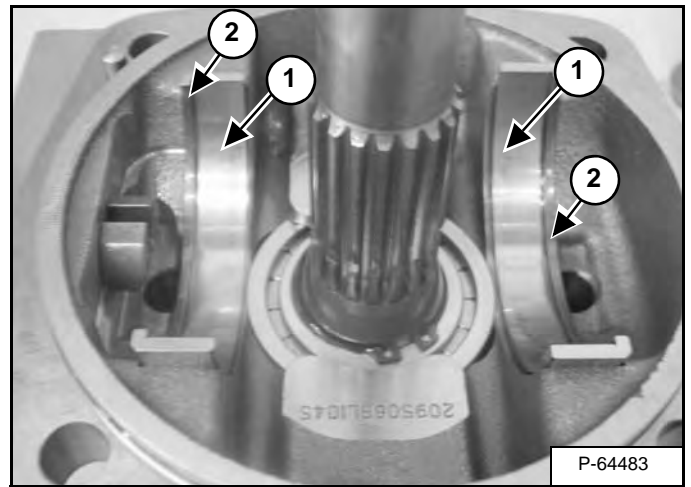

Remove the shell bearing races (Item 1) [Figure 30-51-55].

Assembly: Note shell bearing races have an edge (Item 2) [Figure 30-51-55] on them. The edges face towards the outside of the endcap housing

Inspect bearing surfaces for scratches or scoring.

HYDROSTATIC PUMP (SJC) (CONT'D)

Mechanical Neutral Adjustment (Cont'd)

Figure 30-51-85

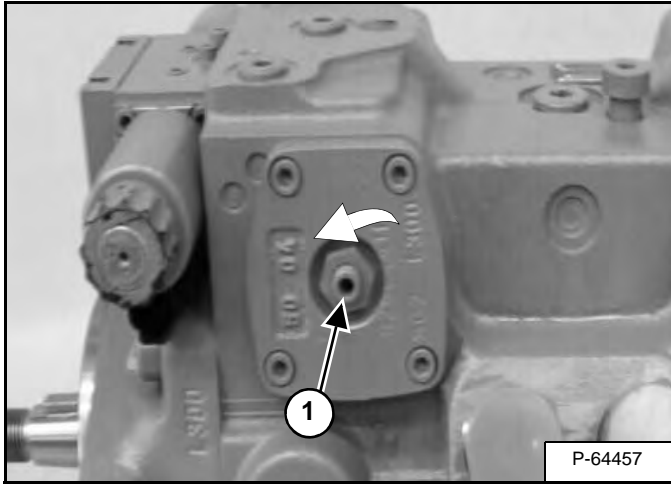

Turn the adjustment screw (Item 1) [Figure 30-51-85] counterclockwise, until the other gauge registers an increase in system pressure. Mark the position of the adjustment screw.

Figure 30-51-86

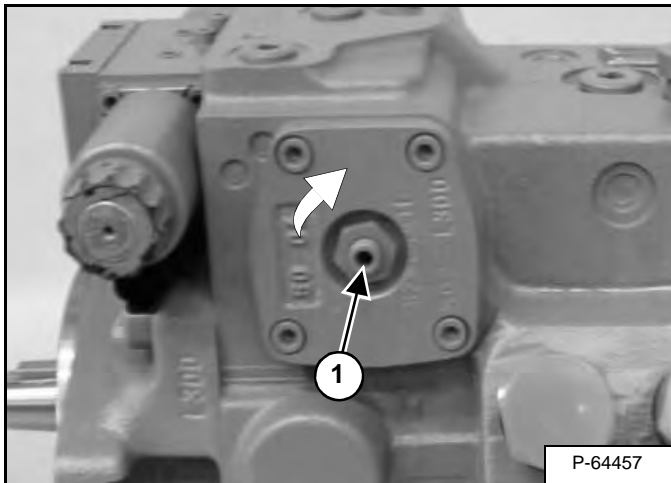

Turn the adjustment screw (Item 1) [Figure 30-51-86] clockwise, to a position halfway between the recorded positions. The pressure gauges should read equal pressures.

Figure 30-51-87

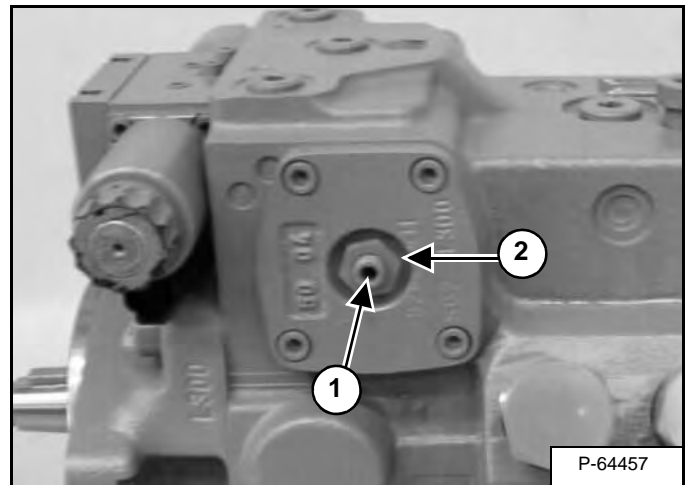

While holding the adjustment screw (Item 1) in position, tighten the lock nut (Item 2) [Figure 30-51-87] to 22 ft.-lb. (30 N•m) torque.

Shut loader OFF.

Remove the hydraulic hose from the X1 and X2 ports on the pump. Install the plugs and tighten to 18 ft.-lb. (25 N•m) torque.

Remove the pressure gauges from the MA and MB ports on the pump. Install the plugs and tighten to 18 ft.-lb. (25 N•m) torque.

NOTE: The Hydraulic Controller Neutral Adjustment must be performed whenever the Mechanical Neutral Adjustment is done. (See Hydraulic Controller Neutral Adjustment on Page 30-41-30.)

CASE DRAIN FILTER

Description

The case drain filter is an external filter assembly in the case drain circuit that filters the case drain hydraulic oil. The case drain filter can be replaced as a complete assembly or disassembled to replace the element with an element kit and/or the spring kit purchased from Bobcat Parts.

Disassembly And Assembly

Remove the case drain filter(s) from the machine. (See Removing And Replacing Hydraulic Fluid on Page 10-120-2.)

Figure 30-70-1

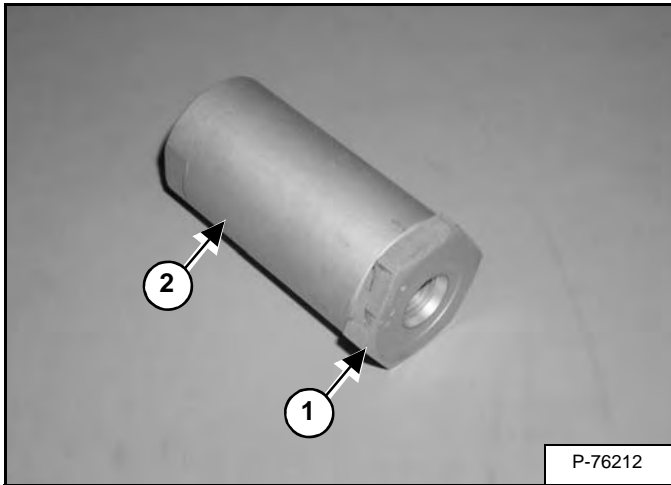

Remove the filter housing nut (Item 1) from the filter housing (Item 2) [Figure 30-70-1].

Figure 30-70-2

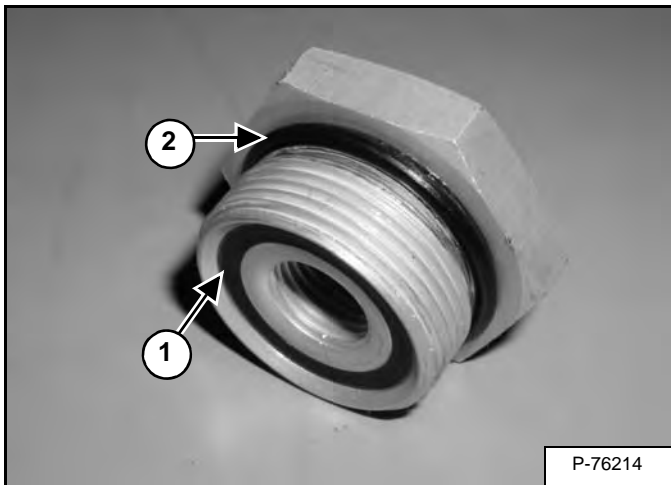

Remove the packing (Item 1) and O-ring (Item 2) [Figure 30-70-2] from the filter housing nut.

Figure 30-70-3

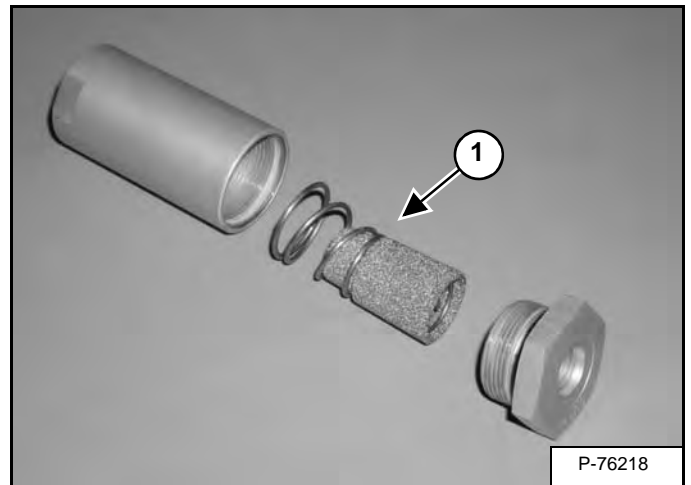

Remove the filter element and spring assembly (Item 1) [Figure 30-70-3]

NOTE: Remember the orientation of the filter element and spring assembly for correct assembly.

Figure 30-70-4

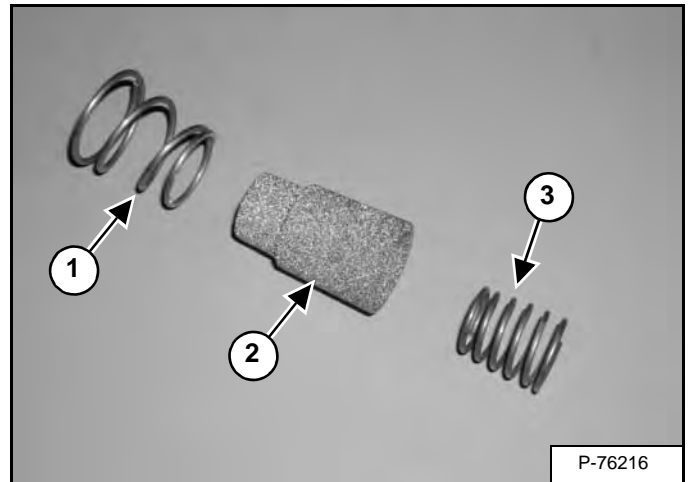

The larger taper spring (Item 1) slides over the end of the filter element (Item 2) and the smaller tapered spring (Item 3) [Figure 30-70-4] slides into the filter element.

BRAKE (CONT'D)

Block Disassembly And Assembly (Cont'd)

Figure 40-10-20

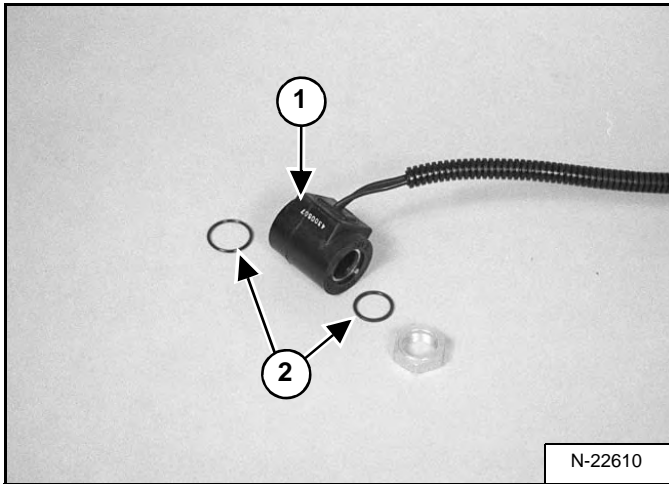

Use a test meter and test the solenoid (Item 1) [Figure 40-10-20] for resistance.

The resistance value for the solenoid coil can be found on the electrical schematic.

Replace the O-rings (Item 2) [Figure 40-10-20].

Figure 40-10-21



Assembly: Always install new O-rings. Tighten the solenoid valve to 20 ft.-lb. (27,1 N•m) torque.

Check the O-rings [Figure 40-10-21] and replace as needed.

CLICK HERE TO **DOWNLOAD** THE COMPLETE MANUAL

- Thank you very much for reading the preview of the manual.
- You can download the complete manual from: www.heydownloads.com by clicking the link below



- Please note: If there is no response to CLICKING the link, please download this PDF first and then click on it.

CLICK HERE TO **DOWNLOAD** THE COMPLETE MANUAL

SEAT BAR

Description

The seat bar is the secondary restraint system that has a sensor that automatically stops the loader functions until the seat bar is lowered.

The seat bar is located in the operator cab.

Removal And Installation

Figure 50-10-1

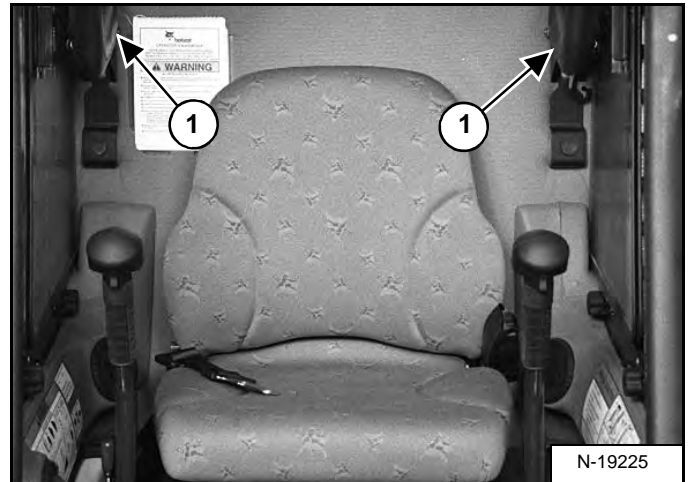

Raise the seat bar (Item 1) [Figure 50-10-1].

Figure 50-10-2

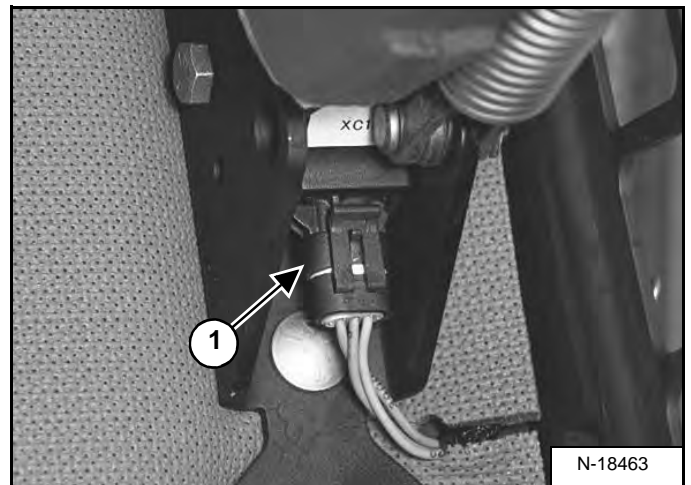

Disconnect the seat bar sensor (Item 1) [Figure 50-10-2] from the cab harness.

Lower the seat bar.

OPERATOR SEAT

Removal And Installation

Figure 50-30-1

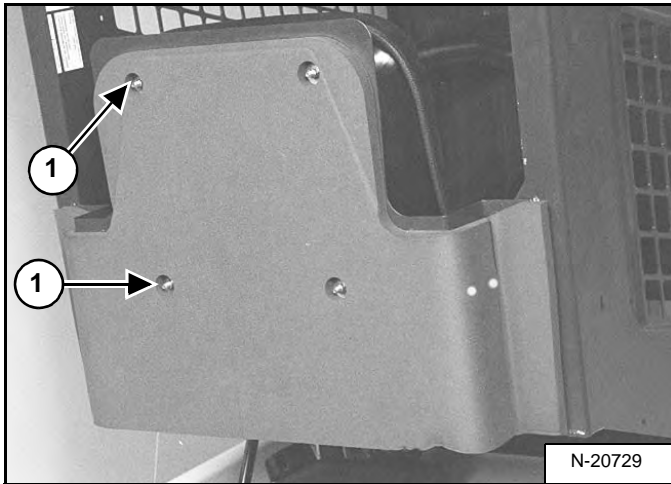

Raise the operator cab. (See Raising on Page 10-30-1.)

Remove the four seat mounting nuts (Item 1) [Figure 50-30-1] and washers from the operator seat mounting studs.

Installation: Tighten the mounting nuts to 20 ft.-lb. (27 N•m) torque.

NOTE: Ensure the washers are installed.

Figure 50-30-2

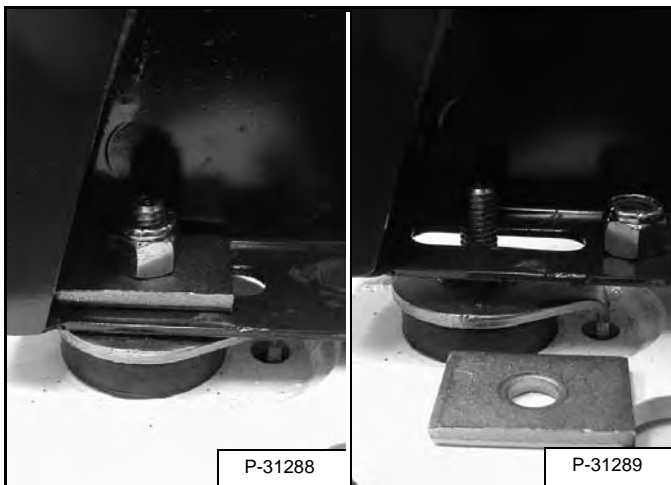

Lower the cab and install one of the mounting washer and nut [Figure 50-30-2].

NOTE: With the seat removed the cab will raise.

Reverse the removal procedure to install the operator seat.

Seat Belt Removal And Installation

Figure 50-30-3

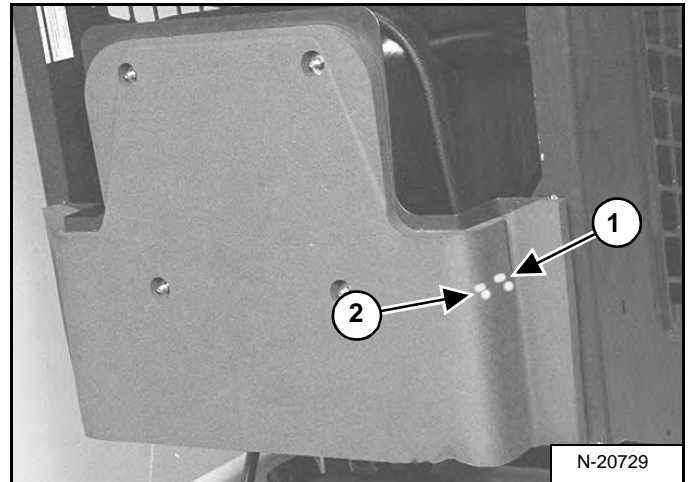

Raise the operator cab. (See Raising on Page 10-30-1.)

Locate the seat belt bolts under seat pan insulation (Items 1 & 2) [Figure 50-30-3] and peel back or cut insulation to gain access to the head.

Figure 50-30-4

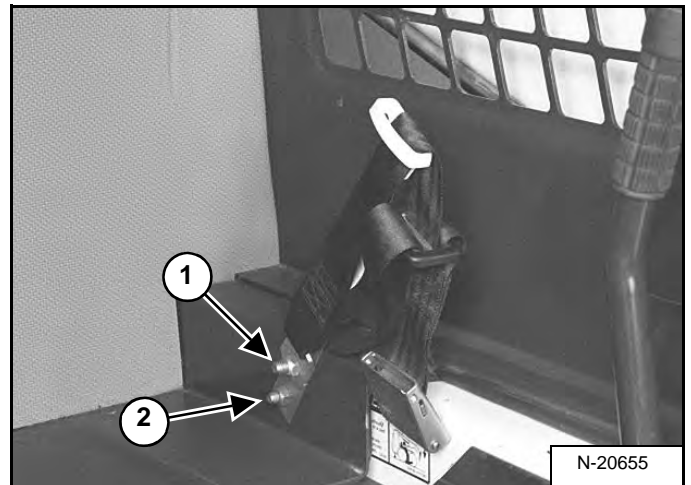

Remove the two nuts (Items 1 & 2) [Figure 50-30-4].

Installation: Tighten nut (Item 1) [Figure 50-30-4] to 54 ft.-lb. (73 N•m) torque. Tighten nut (Item 2) [Figure 50-30-4] to 34 ft.-lb. (46 N•m) torque.

Repeat for other half of seat belt and guide.

BOB-TACH (HAND LEVER) (CONT'D)

Removal And Installation (Cont'd)

Figure 50-40-7

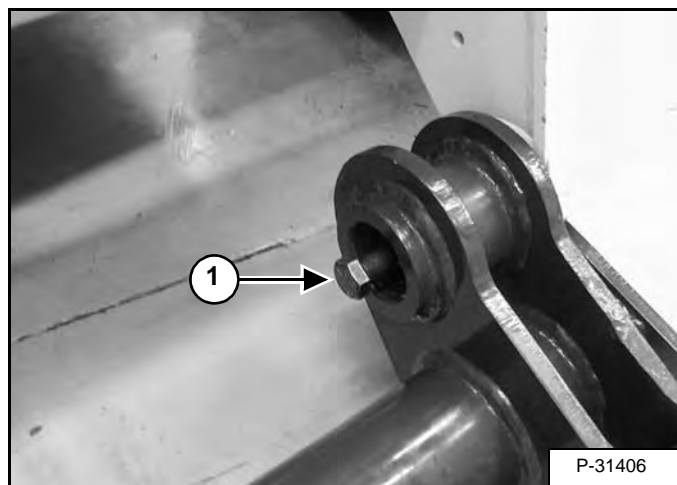

Remove the retainer bolt (Item 1) [Figure 50-40-7] from the Bob-Tach pin.

Figure 50-40-8

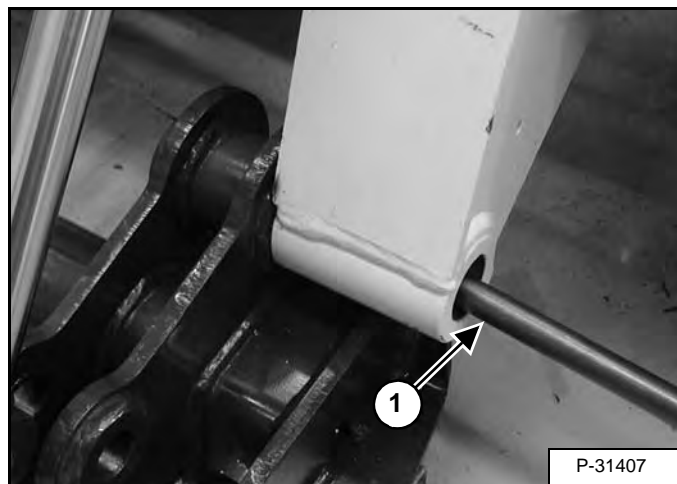

With a 7/8 in. (0.875 mm) drift (Item 1) [Figure 50-40-8] and a hammer, drive the pivot pin out of the lift arm & Bob-Tach.

LIFT ARMS

Stabilizer Bar Removal And Installation

Figure 50-50-1

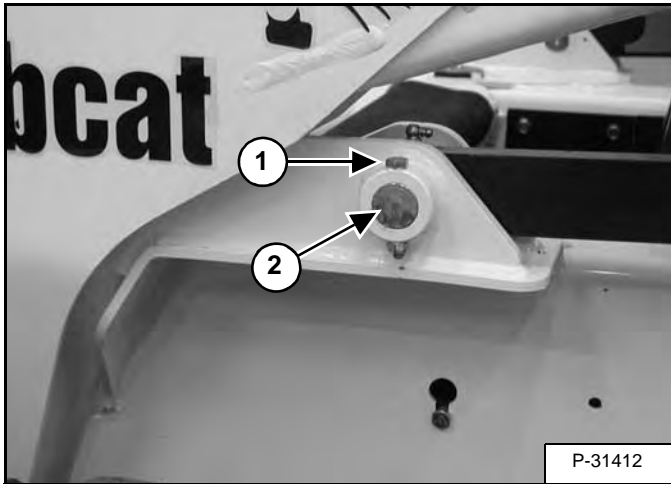

Raise the operator cab. (See Raising on Page 10-30-1.)

NOTE: Remove the lift arm stabilizer bar from one side of the loader at a time.

Remove the retainer bolt (Item 1) [Figure 50-50-1] and nut from the front stabilizer bar pivot pin.

Remove the stabilizer bar pivot pin (Item 2) [Figure 50-50-1].

Figure 50-50-2

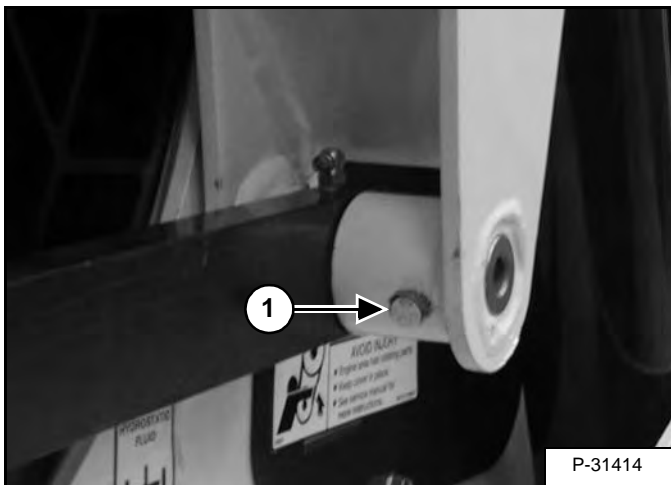

Remove the retainer bolt (Item 1) [Figure 50-50-2] from the stabilizer bar rear pivot pin at the lift arm.

Figure 50-50-3

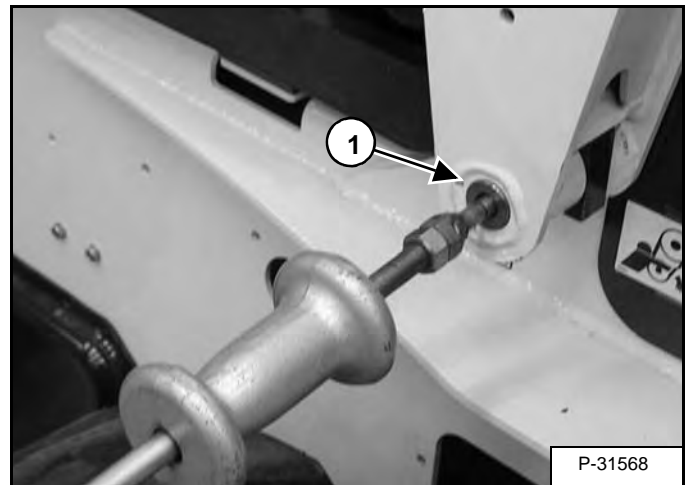

With a slide hammer, remove the rear lift arm stabilizer pin (Item 1) [Figure 50-50-3].

Remove the stabilizer bar from the loader.

Figure 50-50-4

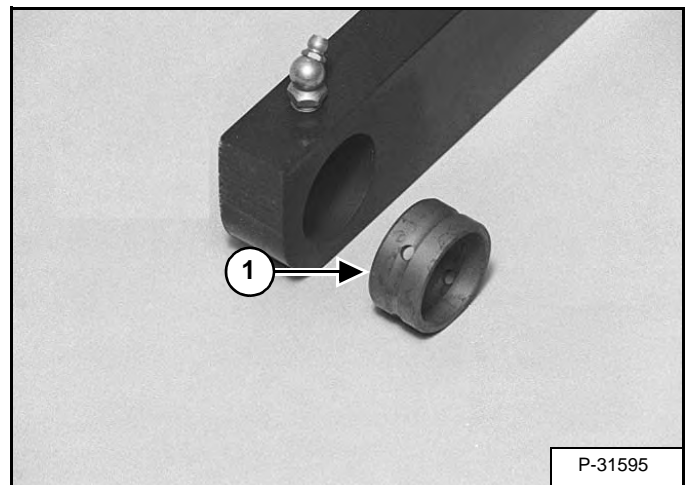

Remove the bushings (Item 1) [Figure 50-50-4] from the stabilizer bar (both ends).

Inspect the bushings and replace as needed.

REAR DOOR (CONT'D)

Striker (Adjusting)

WARNING

AVOID INJURY OR DEATH

Never service or adjust the machine when the engine is running unless instructed to do so in the manual.

W-2012-0497

Figure 50-70-6

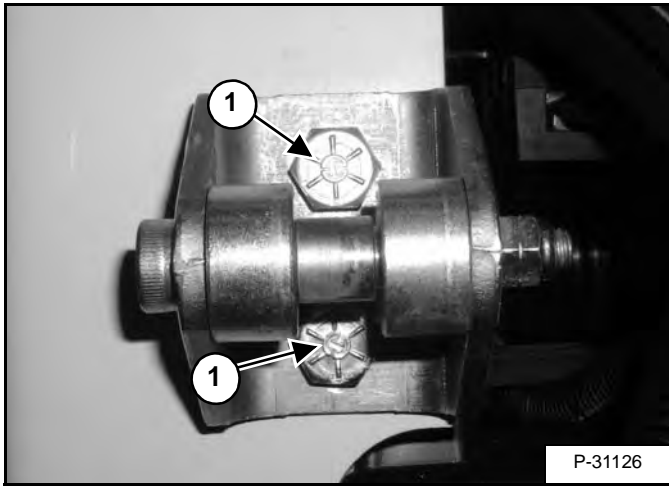

Loosen the striker assembly mount bolts (Item 1) [Figure 50-70-6].

Align the striker assembly in the center of the mounting holes.

NOTE: Tighten the striker assembly, top mount bolt only, until it will hold the striker assembly in the center of the mounting slots.

Close the rear door. (This will align the striker assembly to the correct position.)

Open the door.

Installation: Tighten the mounting bolts (Item 1) [Figure 50-70-6] to 90 - 100 ft.-lb. (125 - 135 N•m) torque.

Close the rear door.

CONTROL PEDALS (ACS)

Description

The control pedals send an electronic pulse to the actuators on the control valve. The electronic pulse tells the actuators to move the lift or tilt spools on the control valve.

The control pedals are located on the lower mainframe at the operators feet.

CONTROL PANEL (CONT'D)

Linkage Removal And Installation (Cont'd)

Figure 50-100-15

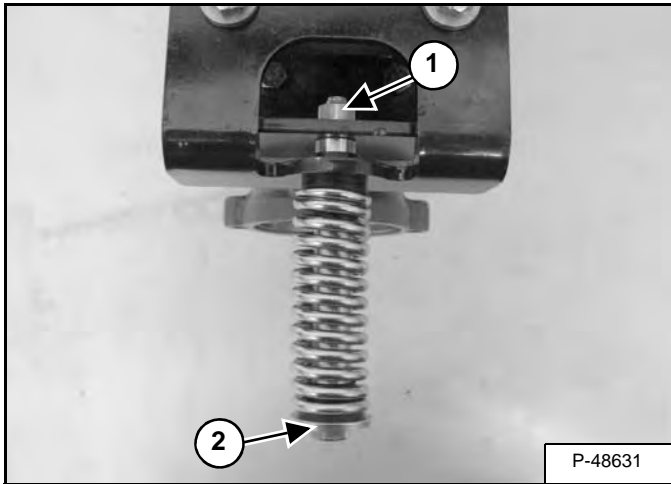

Remove the nut (Item 1) from the end of the centering spring shoulder bolt (Item 2) [Figure 50-100-15].

Remove the bolt / spring assembly.

Installation: Tighten the centering spring bolt and a **NEW** lock nut to 25 - 28 ft.-lb. (34 - 38 N•m) torque.

Figure 50-100-16

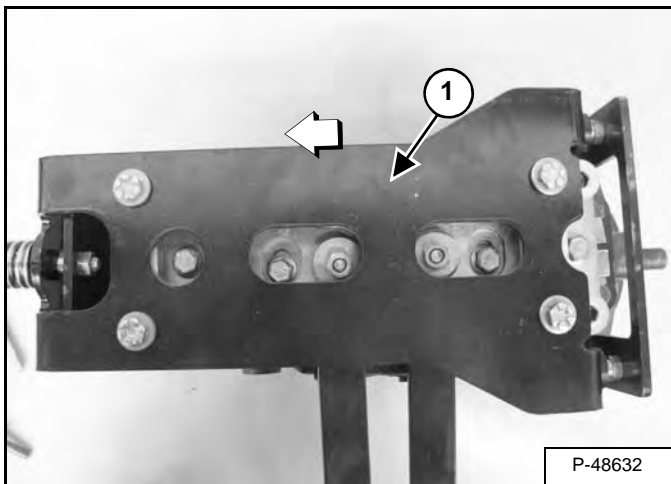

Slide the centering plate (Item 1) [Figure 50-100-16] to the right to remove it from the hydrostatic pumps.

NOTE: Directions are shown and stated as if you were sitting in the operator's seat.

Figure 50-100-17

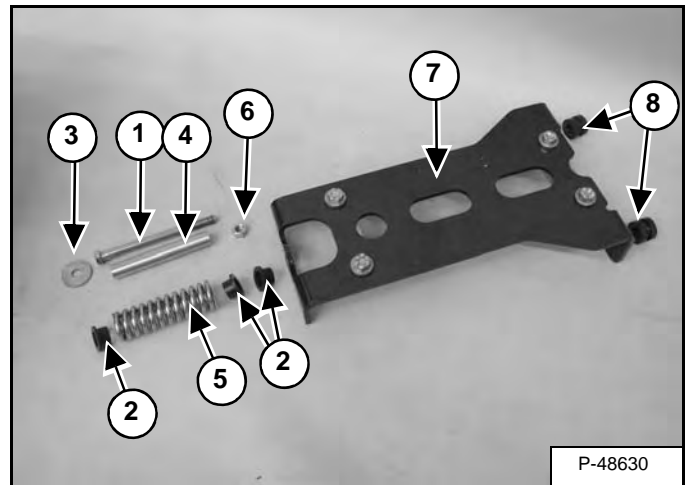

The centering plate / centering spring assembly consists of the following parts:

ITEM	DESCRIPTION
1	Bolt
2	Bushings
3	Washer
4	Bushing Spacer
5	Spring
6	Lock Nut
7	Centering Plate
8	Guide Bushings

CONTROL PANEL (CONT'D)

Linkage Travel (Adjusting) (Cont'd)

Figure 50-100-40

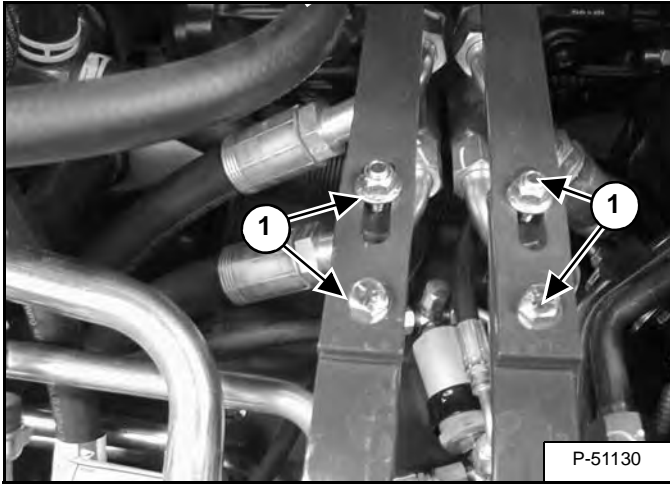

Loosen the two bolts and nuts (Item 1) [Figure 50-100-40] on each steering linkage bar.

Figure 50-100-41



Move the left control lever to the full forward position, then pull forward on the left rear linkage bar until the pintle arm is rotated to the front as far as possible [Figure 50-100-41]. Use a locking plier, clamp the two linkage bars together.

Installation: Tighten the nuts and bolts to 35 - 40 ft.-lb. (47,5 - 54,2 N•m) torque.

Check the lever movement to make sure that the pintle arm and the control lever are both at full stroke at the same time. This will allow for maximum forward speed.

Repeat the linkage travel adjustment procedure for the right side linkage.

Figure 50-100-42

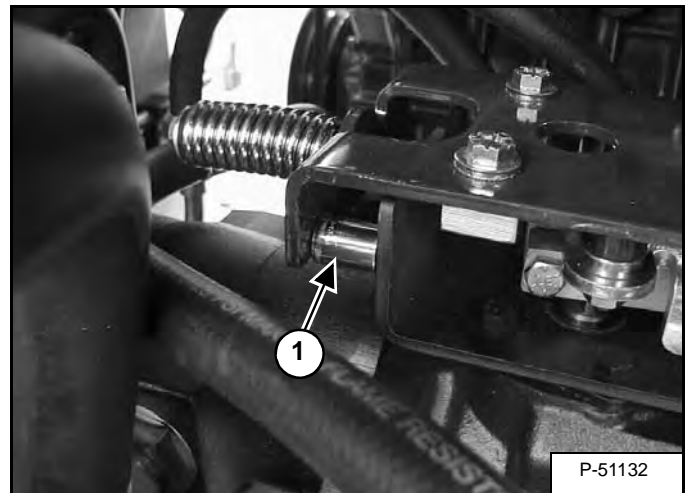

Remove the spacer (Item 1) [Figure 50-100-42].

Figure 50-100-43

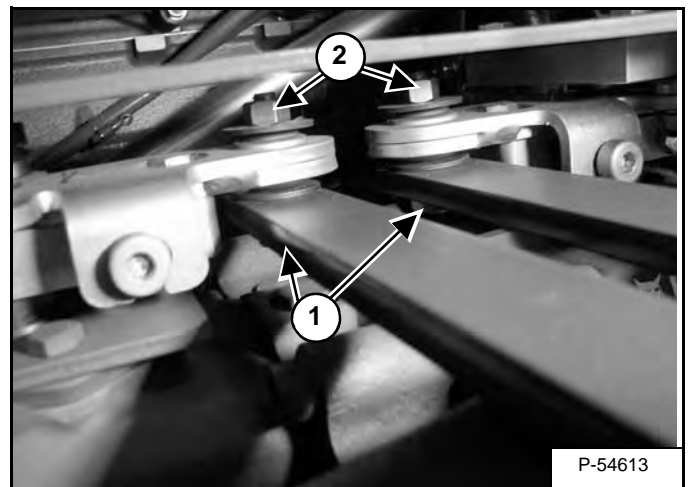

Tighten the two bolts (Item 1) and nuts (Item 2) to 35 - 40 ft.-lb. (47,5 - 54,2 N•m) [Figure 50-100-43].

CONTROL HANDLE / LEVER (ACS) (CONT'D)

Handle Sensor Removal And Installation (Cont'd)

Figure 50-111-8

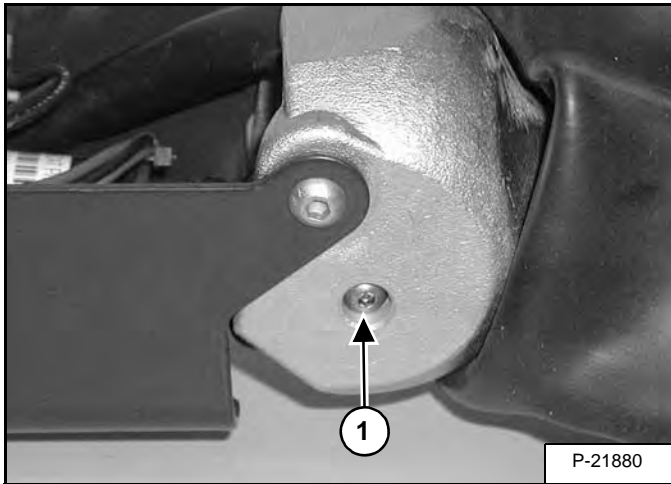

Remove one of the two mounting screws (Item 1) [Figure 50-111-8] from the handle sensor.

Installation: Tighten bolt to 32 - 38 in.-lb. (3,6 - 4,3 N•m) torque.

Figure 50-111-9

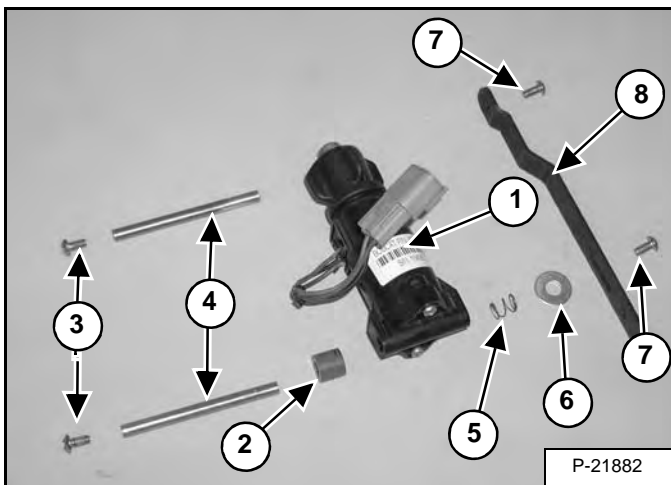

Remove the handle sensor (Item 1) [Figure 50-111-9] from the handle assembly.

NOTE: The handle sensor (Item 1) [Figure 50-111-9] can only be replaced as a complete assembly.

Check the spacers (Item 2), and screws (Item 3), mounting pins (Item 4), spring (Item 5), washer (Item 6), bolt/nut (Item 7), stop strap (Item 8) [Figure 50-111-9] and replace as needed.

Figure 50-111-10

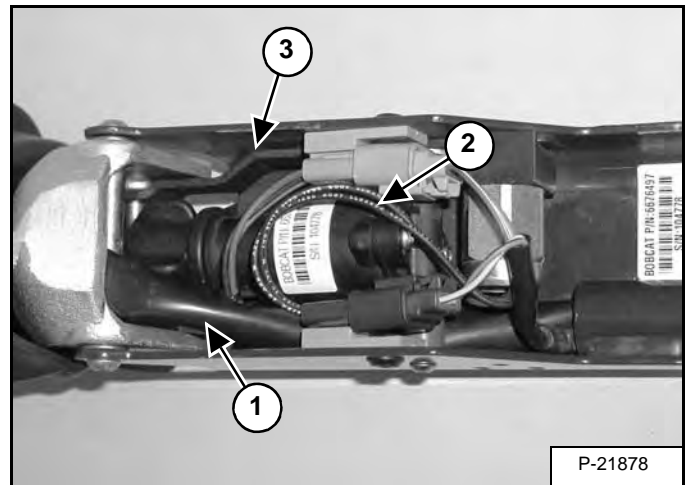
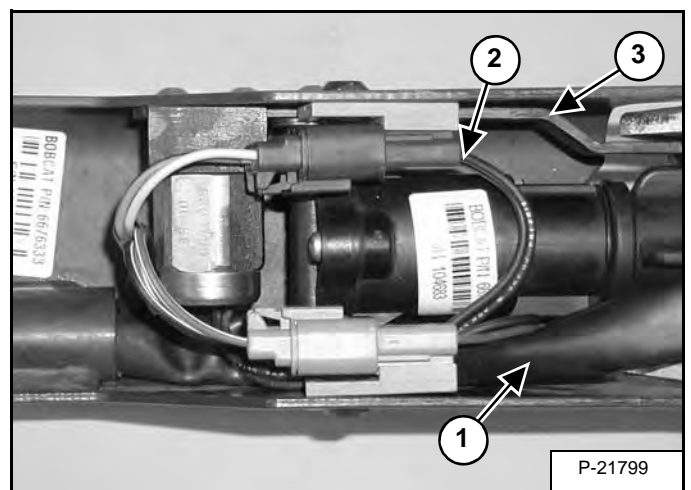

Figure 50-111-11



Installation: When installing the handle sensor into the control handle, check the routing of the switch handle wire harness (Item 1) [Figure 50-111-10] & [Figure 50-111-11] to assure proper return of the control handle to neutral and minimize harness movement.

NOTE: Route wires (Item 2) [Figure 50-111-10] & [Figure 50-111-11] as shown away from stop strap (Item 3) [Figure 50-111-10] & [Figure 50-111-11] to avoid wire damage.

NOTE: The calibration procedure must be followed when replacing handle sensor, foot pedal sensor, actuator or ACS Controller. (See Lift And Tilt Calibration (ACS) on Page 60-160-11.)

ACCESS PANEL (INSIDE)

Removal And Installation (Left)

Figure 50-120-1

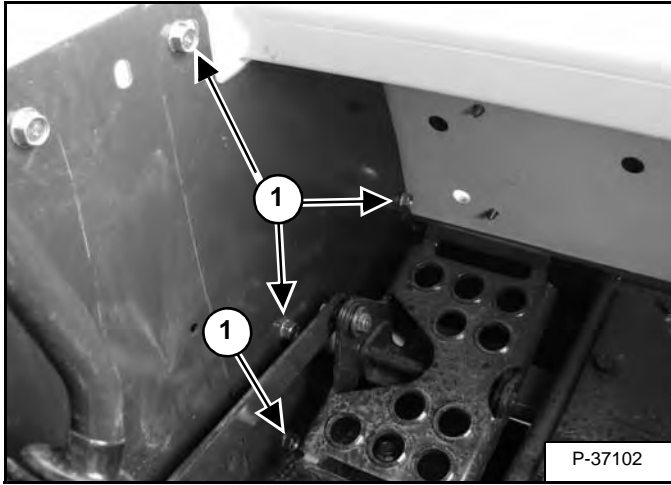

Remove the four mounting bolts (Item 1) [Figure 50-120-1] from the front access panel.

Remove the front access panel from the loader.

Figure 50-120-2

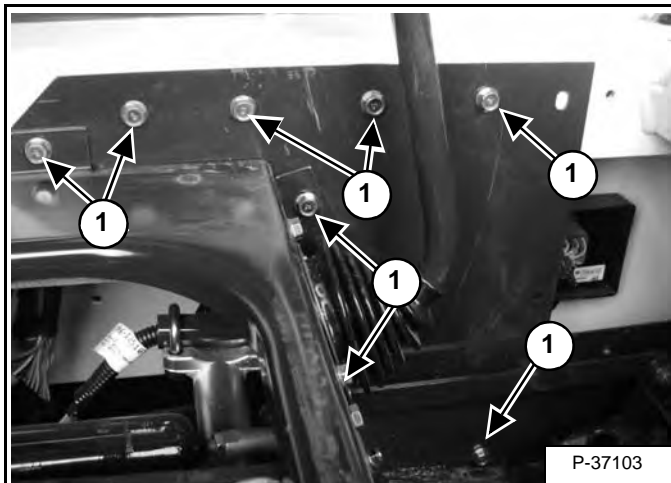

Remove the eight mount bolts (Item 1) [Figure 50-120-2] from the rear access panel.

Remove the rear access panel from behind the steering panel, remove the panel from the loader.

Removal And Installation (Right)

Figure 50-120-3

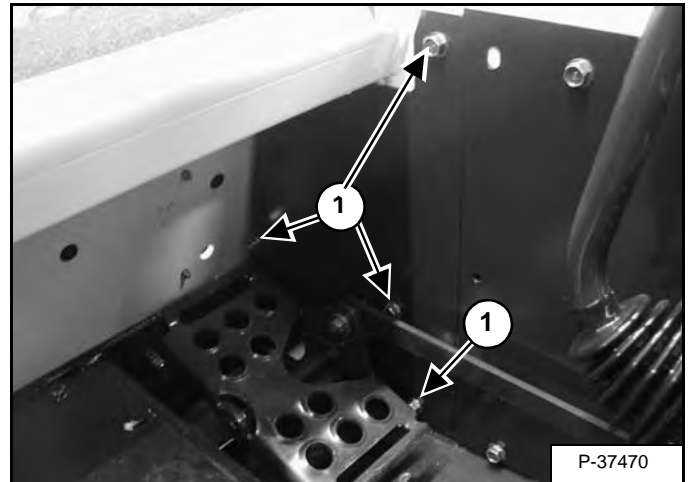

Remove the four mounting bolts (Item 1) [Figure 50-120-3] from the front access panel.

Remove the front access panel from the loader.

Figure 50-120-4

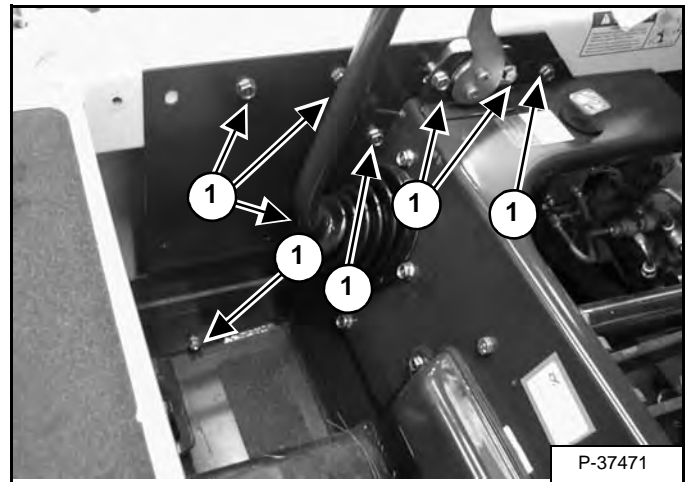

Remove the eight mount bolts (Item 1) [Figure 50-120-4] from the rear access panel.

Remove the throttle lever assembly from the access panel.

Remove the rear access panel from behind the steering panel, remove the panel from the loader.

WINDOW (SIDE)

Removal And Installation

Figure 50-132-1

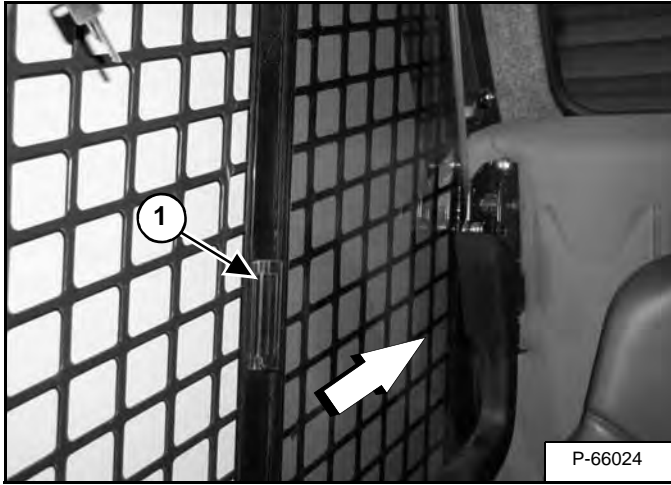

Release the latch (Item 1) [Figure 50-132-1] and slide the front window back towards the rear of the operator cab.

Figure 50-132-2

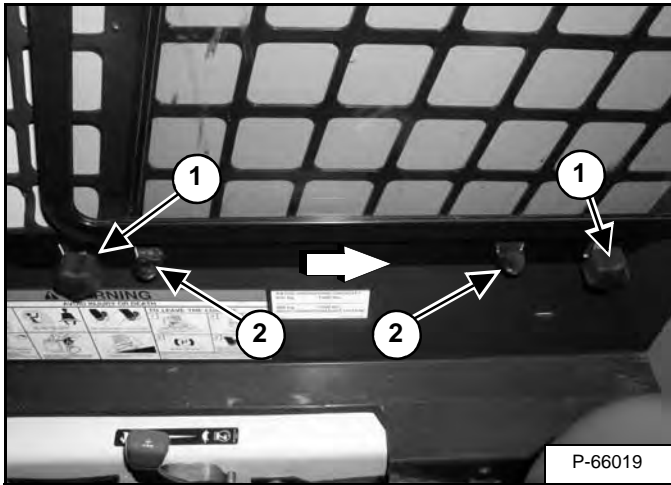

From inside the operator cab, loosen the knobs (Item 1) [Figure 50-132-2] and [Figure 50-132-3] on the window slide rail bolts.

Figure 50-132-3

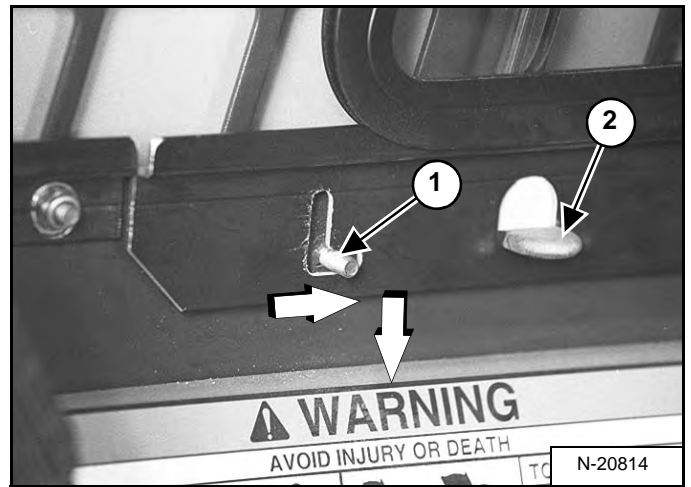

NOTE: [Figure 50-132-3] is shown with the washer and knob removed to illustrate the direction of movement.

Move the window slide rail using the two thumb pads (Item 2) [Figure 50-132-2] and [Figure 50-132-3] towards the rear of the operator cab and then down towards the bottom of the operator cab.

NOTE: The top of the window should come out of the top slide rail at this time. Make sure the window is secure and does not fall. Make sure the slide rails are in alignment and the window is positioned in the top track during installation.

Remove the front side window from the operator cab.

ELECTRICAL SYSTEM & ANALYSIS











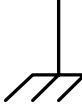
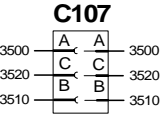

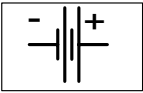
ALTERNATOR	60-30-1
Alternator Voltage Testing	60-30-3
Belt Adjustment	60-30-1
Belt Replacement.	60-30-1
Charging System Inspection	60-30-2
High Voltage Testing	60-30-4
Low Voltage Testing.	60-30-3
Parts Identification	60-30-6
Removal And Installation	60-30-5
BACK-UP ALARM SYSTEM	60-210-1
Adjusting Switch Position.	60-210-2
Alarm Removal And Installation.	60-210-5
Description.	60-210-1
Inspecting.	60-210-1
Switch Removal And Installation	60-210-5
Troubleshooting (Joystick)	60-210-4
Troubleshooting (Standard And ACS)	60-210-3
BATTERY	60-20-1
Removal And Installation	60-20-1
Servicing	60-20-2
Using A Booster Battery (Jump Starting)	60-20-3
BOBCAT CONTROLLER (ACS)	60-71-1
Connector And Wire Identification	60-71-2
Description.	60-71-1
Removal And Installation	60-71-3
BOBCAT CONTROLLERS (GATEWAY AND AUXILIARY).	60-70-1
Connector Identification	60-70-2
Description.	60-70-1
Removal And Installation	60-70-8
BOBCAT CONTROLLER (SJC) (DRIVE)	60-72-1
Connector Identification	60-72-2
Description.	60-72-1
Removal And Installation	60-72-4

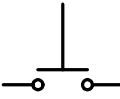
**ELECTRICAL
SYSTEM &
ANALYSIS**

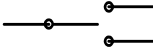
Continued On Next Page

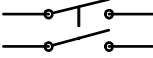
ELECTRICAL SYSTEM INFORMATION

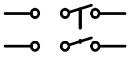
Glossary Of Electrical Symbols

SYMBOL	DESCRIPTION	SYMBOL	DESCRIPTION
CONNECTIONS			
	<p>CONNECTOR - Harness - Used for connecting 2 harnesses together or a harness to a component. The connector can vary from a single pin to any number of pins (Example: 3 pin connectors shown). The connector pins can be numbered alphabetical (shown) or numerical (1, 2, 3 etc.). The harness wires numbers are called out next to the connector (Example: 3500).</p>		<p>GROUND - Frame - Used to represent an component that is internally grounded.</p>
	<p>The connector number is called out next to the connector (Example: C107). These connector numbers are used for schematic identification only and do not appear on the harness or connector.</p>		LIGHT -
COMPONENTS			
	BATTERY - Used for supplying and storing electrical power for the machine.		SWITCH - Single Pole - Single Throw (ON-OFF) Normally Open
	POSITIVE ELECTRICAL CIRCUIT - Indicates positive battery circuit.		SWITCH - Single Pole - Single Throw (ON-OFF) Normally Closed.
	NEGATIVE ELECTRICAL CIRCUIT - Indicates battery ground circuit.		SWITCH - Single Pole - Double Throw (ON-OFF-ON) - This switch can be in any of three positions. (Some switches are spring activated to return them to a certain position when released.)
	ALTERNATOR - Used to create the electrical current to supply voltage to the battery and components.		SWITCH - Double Pole - Single Throw (ON-OFF) Open and Closed positions will be specified depending on switch application.)
	STARTER - Uses battery current to start the machine engine.		SWITCH - Double Pole - Double Throw (ON-OFF) Open and Closed positions will be specified depending on switch application.
	GROUND - Used to represent an external ground connection.		POTENTIOMETER - Variable resistance - Provides variable resistance.

BATTERY

Removal And Installation

WARNING

AVOID INJURY OR DEATH

Batteries contain acid which burns eyes and skin on contact. Wear goggles, protective clothing and rubber gloves to keep acid off body.

In case of acid contact, wash immediately with water. In case of eye contact get prompt medical attention and wash eye with clean, cool water for at least 15 minutes.

If electrolyte is taken internally drink large quantities of water or milk! DO NOT induce vomiting. Get prompt medical attention.

W-2065-0807

Open the rear door.

Figure 60-20-1

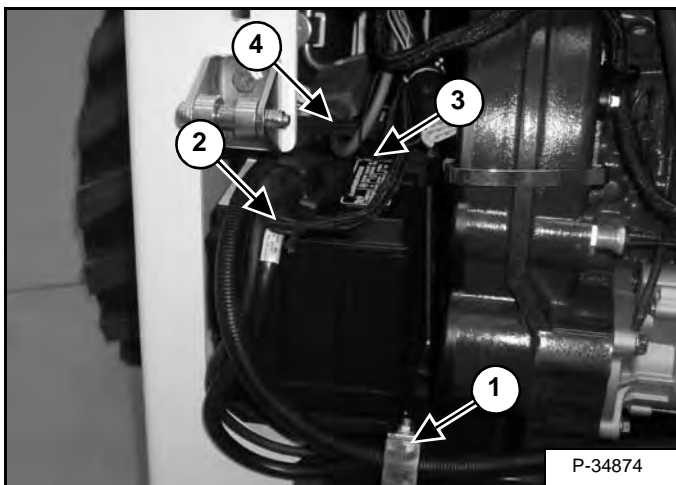

Remove the harness clamp (Item 1) [Figure 60-20-1].

Disconnect the negative (-) cable (Item 2) [Figure 60-20-1].

Remove the battery hold down clamp (Item 3) [Figure 60-20-1].

Disconnect the positive (+) cable (Item 4) [Figure 60-20-1] from the battery.

Remove the battery from the loader.

Figure 60-20-2

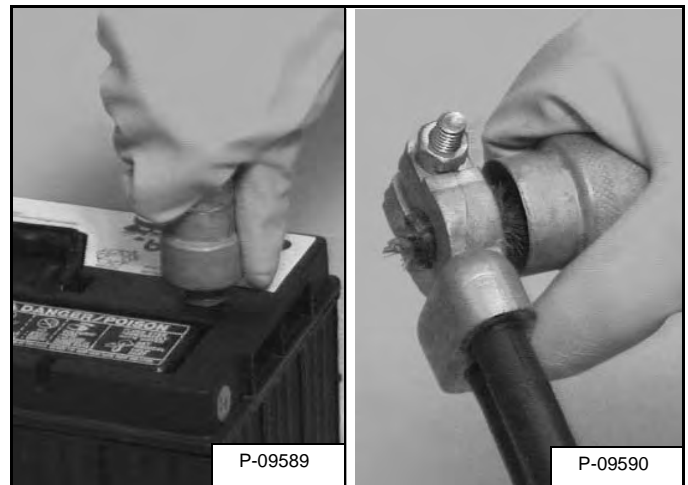

Always clean the battery terminals and cable ends when installing a new or used battery [Figure 60-20-2].

When installing the battery in the loader, do not touch any metal parts with the battery terminals.

Connect the negative (-) cable last to prevent sparks.

Connect and tighten the battery cables.

Install and tighten the battery hold down.

Install the harness clamp.

WARNING

AVOID INJURY OR DEATH

Keep arcs, sparks flames and lighted tobacco away from batteries. When *jumping* from booster battery make final connection (negative) at machine frame.

Do not jump start or charge a frozen or damaged battery. Warm battery to 60°F (16°C) before connecting to a charger. Unplug charger before connecting or disconnecting cables to battery. Never lean over battery while boosting, testing or charging.

Battery gas can explode and cause serious injury.

W-2066-0705

STARTER

Testing

Figure 60-40-1

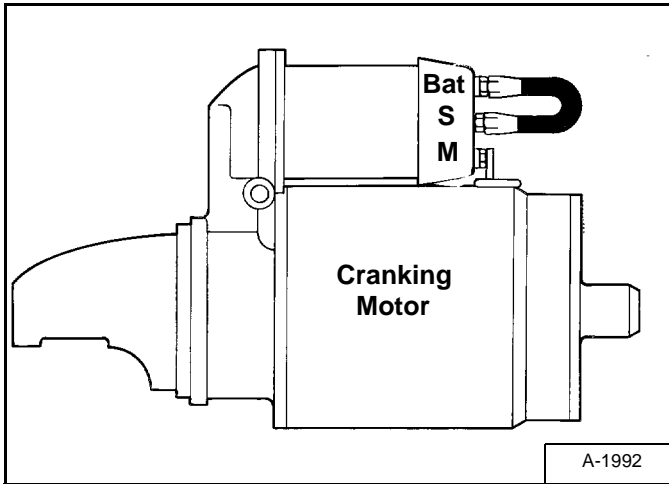

The key switch must be in the OFF position.

The battery must be at full charge.

The cable connections on the battery must be clean and tight.

Connect a jumper wire between S terminal and BAT terminal [Figure 60-40-1].

If the starter turns but does not turn the engine, the starter drive has a defect.

Figure 60-40-2

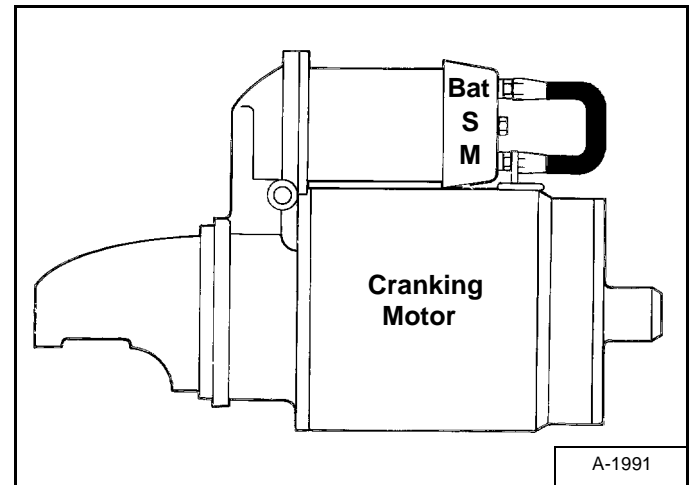

Connect a jumper wire (of at least 4 gauge in size) between the M terminal and the BAT terminal [Figure 60-40-2].

If the starter turns, the defect is in the solenoid.

If the starter does not turn, the starter is defective.

INSTRUMENT PANELS (CONT'D)

Front Panel Removal And Installation

Figure 60-50-7

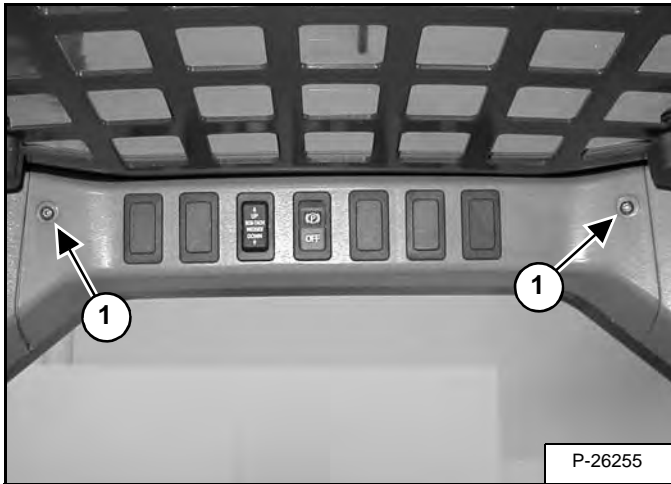

Remove the two mounting bolts (Item 1) [Figure 60-50-7].

Installation: Be careful to not overtighten the front accessory panel mounting bolts to prevent damage to the plastic panel.

Figure 60-50-8

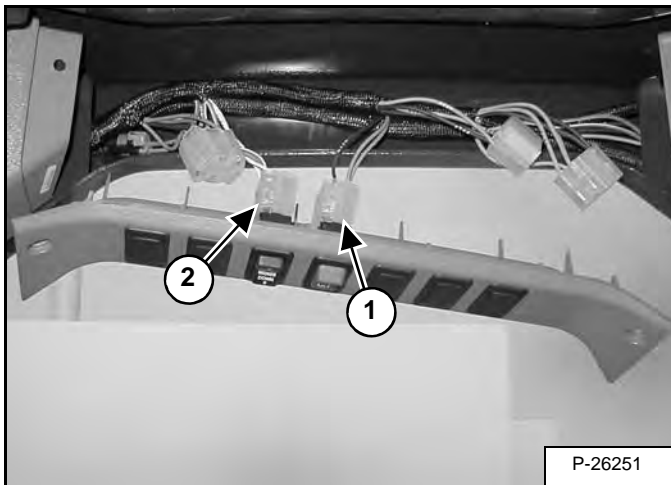

Pull the front accessory panel down and disconnect the wire harness connector(s) (Items 1 & 2) [Figure 60-50-8] from the switches.

Remove the panel.

Removal And Installation (Left And Right)

Figure 60-50-9

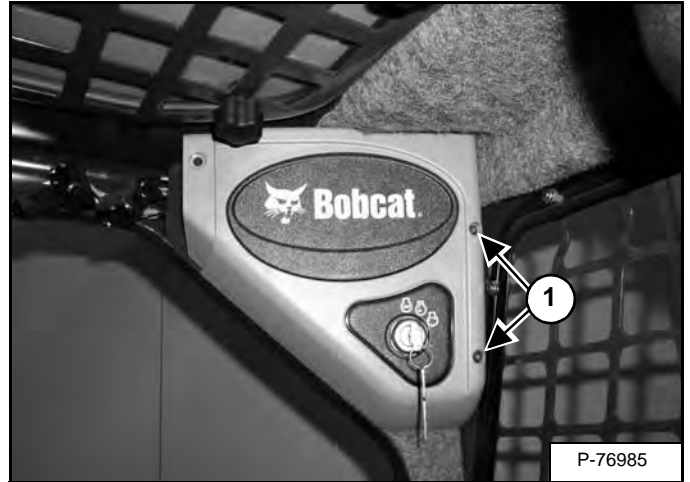

Remove the two mounting bolts (Item 1) [Figure 60-50-9].

Installation: Be careful to not overtighten the instrument panel mounting bolts to prevent stripping of the threaded holes in the panels.

Figure 60-50-10

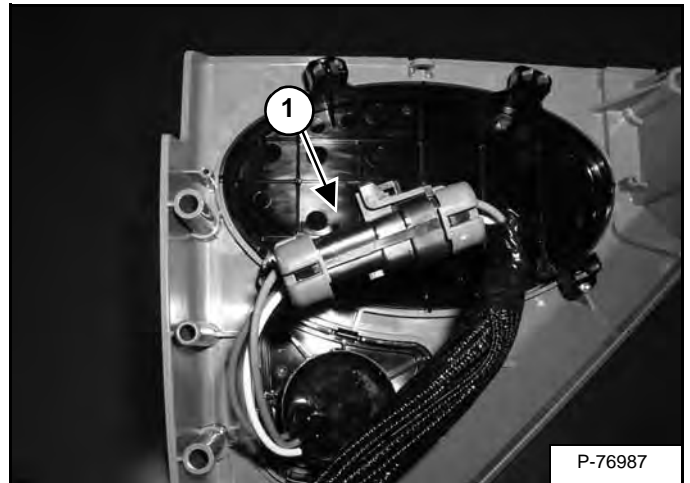

Pull the right instrument panel down and disconnect the wire harness connector (Item 1) [Figure 60-50-10] from the panel.

Remove the panel from the loader cab.

BOBCAT CONTROLLERS (GATEWAY AND AUXILIARY) (CONT'D)

Connector Identification (Cont'd)

Auxiliary Controller

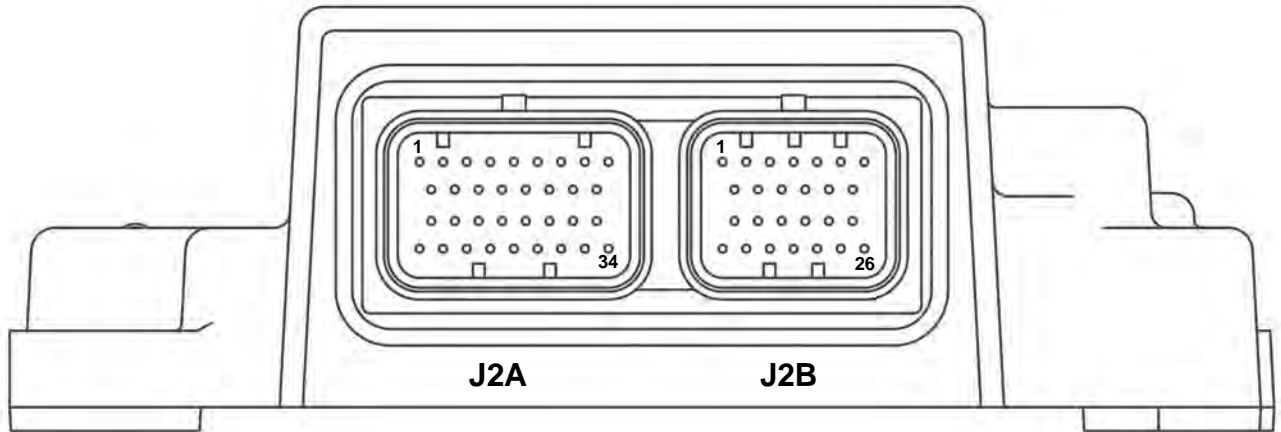

Harness Connector View



J2A

Harness Connector View

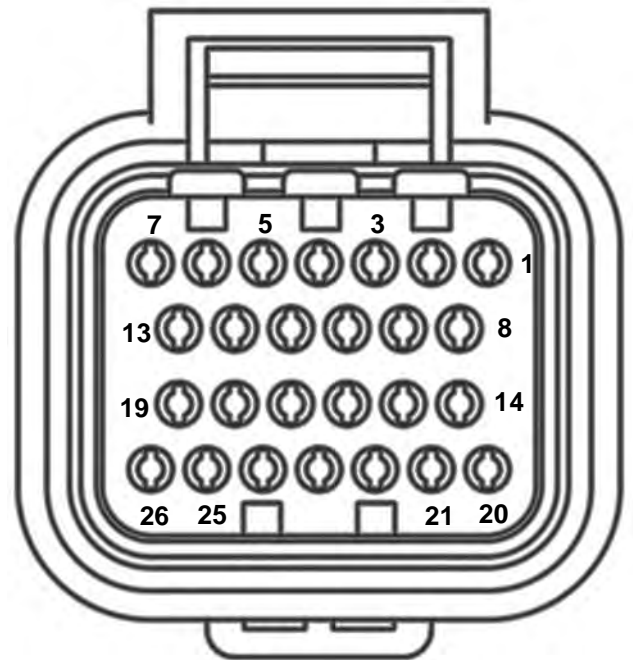

J2B

P-76647
P-76646
P-76645

BOBCAT CONTROLLER (SJC) (DRIVE) (CONT'D)

Connector Identification (Cont'd)

SAFETY IN 1 9420	OPEN 2	OPEN 3	H-PATTERN SWITCH 4 4550	OPEN 5		ISO LIGHT 6 4220	LEFT SWASH ANGLE 7 4950	RIGHT SWASH ANGLE 8 4720	OPEN 9	OPEN 10
LEFT FORWARD RETURN 11 2670	CAN HIGH 12 9530	LEFT FRONT ANGLE 13 3040	RIGHT FRONT ANGLE 14 3140	LEFT REAR ANGLE 15 3030		H-PATTERN LIGHT 16 4275	R REAR ANGLE 17 3130	LEFT JOYSTICK X-AXIS 18 4530	LEFT JOYSTICK Y-AXIS 19 4540	OPEN 20
LEFT FWD DRIVE 21 4270	CAN LOW 22 9630	RIGHT WHEEL SPEED A 23 3000	RIGHT WHEEL SPEED B 24 3070	TWO SPEED 25 4350		BRAKE LIGHT 26 4210	GROUND 27 2470	GROUND 28 2490	SENSOR GROUND 29 2510	5V SUPPLY WHEEL ANGLE 30 1590
LEFT REVERSE DRIVE 31 4280	CAN SHIELD 32 9730	LEFT WHEEL SPEED A 33 3020	LEFT WHEEL SPEED B 34 3080	SAFETY OUT 35 9410		BACKUP ALARM 36 7100	OPEN 37	OPEN 38	OPEN 39	5V SUPPLY WHL SPD - JOYSTICK 40 1640
LEFT REVERSE RETURN 41 2680	RIGHT FORWARD RETURN 42 2660	RIGHT FORWARD DRIVE 43 4260	RIGHT REVERSE DRIVE 44 4250	RIGHT REVERSE RETURN 45 2650		TWO SPEED 2 46 4390	UNSWITCH BATT #1 47 1250	UNSWITCH BATT #2 48 1260	OPEN 49	SWITCHED POWER 50 1750

DIAGNOSTIC SERVICE CODES (CONT'D)

Service Codes List (Cont'd)

CODE	DESCRIPTION	CODE	DESCRIPTION
M5002	Front light output error ON	W3231	Tilt actuator fault
M5003	Front light output error OFF	W3234	Tilt actuator not in neutral
M5007	Front light output open circuit	W3235	Tilt handle / pedal not in neutral
M5028	Front light output failure	W3236	Lift actuator fault
M5102	Rear light output error ON	W3239	Lift actuator not in neutral
M5103	Rear light output error OFF	W3240	Lift handle / pedal not in neutral
M5107	Rear light output open circuit	W3249	Lift actuator short to ground
M5128	Rear light output failure	W3250	Tilt actuator short to ground
M5202	PTOL switch error ON	W3251	Lift actuator short to battery
M5221	PTOL switch out of range high	W3252	Tilt actuator short to battery
M5222	PTOL switch out of range low	W3253	Lift handle / pedal short to ground
M5305	PTOL LED short to battery	W3254	Tilt handle / pedal short to ground
M5306	PTOL LED short to ground	W3255	Lift handle / pedal short to battery
M5405	Tilt spool lock short to battery	W3256	Tilt handle / pedal short to battery
M5406	Tilt spool lock short to ground	W3257	Lift actuator reduced performance
M5407	Tilt spool lock open circuit	W3258	Tilt actuator reduced performance
M5432	Tilt spool lock overcurrent	W3259	Lift actuator wrong direction
M6402	Switched power relay error ON	W3260	Tilt actuator wrong direction
M6403	Switched power relay error OFF	W3261	Handle lock short to ground
M7002	Switched power output error ON	W3262	Handle lock short to battery
M7003	Switched power output error OFF	W3263	Pedal lock short to ground
M7007	Switched power output open circuit	W3264	Pedal lock short to battery
M7028	Switched power output failure	W3265	Sensor supply out of range
M7304	Remote control no communication	W3266	Battery voltage out of range
M7423	Main controller unprogrammed	W3267	Handle/pedal switch flipped while operating
M7504	Drive no communication	W3275	Recovery mode error
M7604	Left display panel no communication	W3276	CAN joystick information error
M7748	Key switch multiple	W3277	Remote control information error
M7974	Door open	W3905	Left joystick X-axis not in neutral
		W4005	Right joystick X-axis not in neutral
W3223	ACS calibration required	W4007	Right joystick Y-axis not in neutral
W3224	ACS calibration performed		

SEAT BAR SENSOR (CONT'D)

Bobcat Interlock Control System (BICS) Circuit Test

This (BICS) circuit test is for the seat bar section only.

Figure 60-110-8

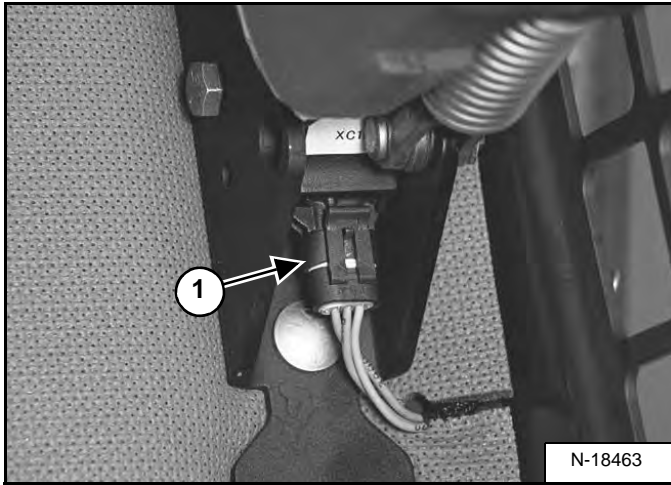

Use Sensor Testers (MEL1428) and seat bar sensor tester adapter (MEL1567) for the following procedure:

Connect the seat bar sensor tester adapter MEL1567 to the sensor tester.

Disconnect the seat bar sensor connector (Item 1) [Figure 60-110-8].

Figure 60-110-9

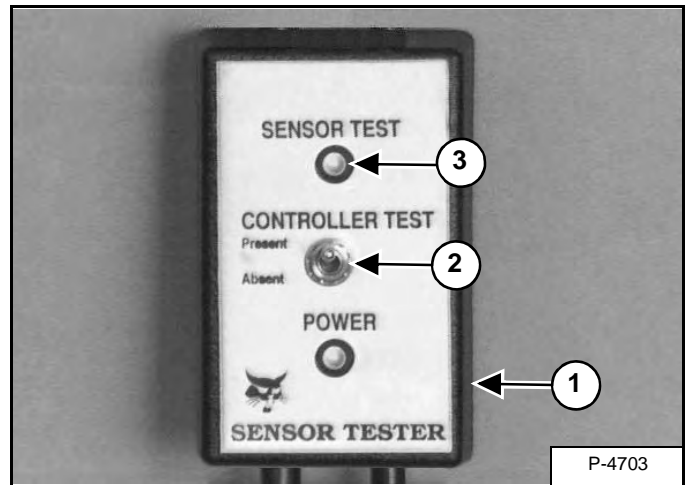

Connect Sensor Tester (Item 1) [Figure 60-110-9] inline to the seat bar sensor connectors.

Turn the key to the ON position. DO NOT START THE ENGINE.

If there is no power light on the sensor tester, check the tester or wiring harness.

When the power light is illuminated, move the toggle switch (Item 2) [Figure 60-110-9] on the sensor tester to the Present position.

NOTE: The sensor test light (Item 3) [Figure 60-110-9] is only activated by the seat bar. It will be off with the seat bar up or on with the seat bar down.

CONTROL SYSTEM (ACS)

Description

The ACS option allows the operator to quickly switch between foot and hand control modes. It uses the electric actuators to control the lift and tilt spools, foot sensors, handle sensors and a specially designed control handle.

CONTROL SYSTEM (ACS) (CONT'D)

Handle Lock Solenoid Disassembly And Assembly

Figure 60-130-26

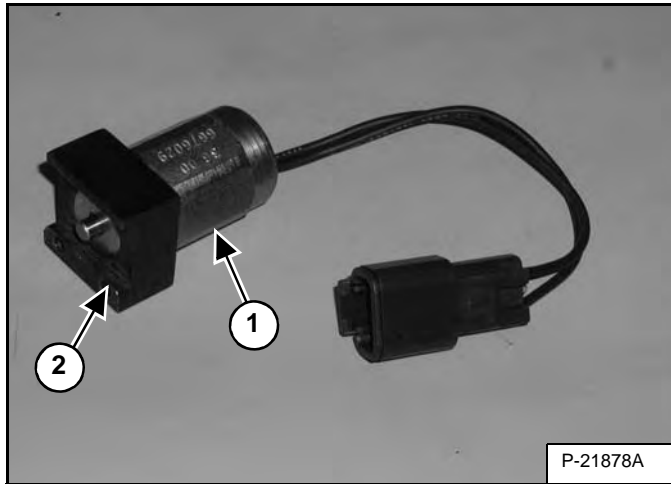

Remove solenoid (Item 1) from the solenoid mount (Item 2) [Figure 60-130-26].

Installation: Apply a drop of oil to the solenoid threads and tighten solenoid to 35 - 40 ft.-lb. (47 - 54 N•m) lubed torque.

Figure 60-130-27

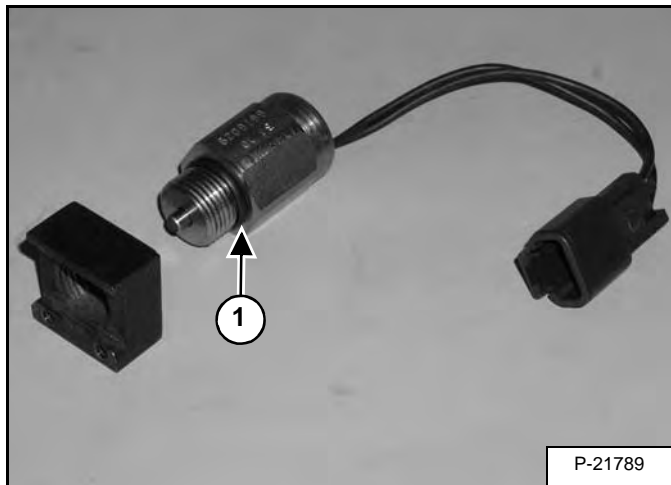

Check the O-ring (Item 1) [Figure 60-130-27] for damage. Replace as necessary.

Foot Sensor Disassembly And Assembly

Figure 60-130-28

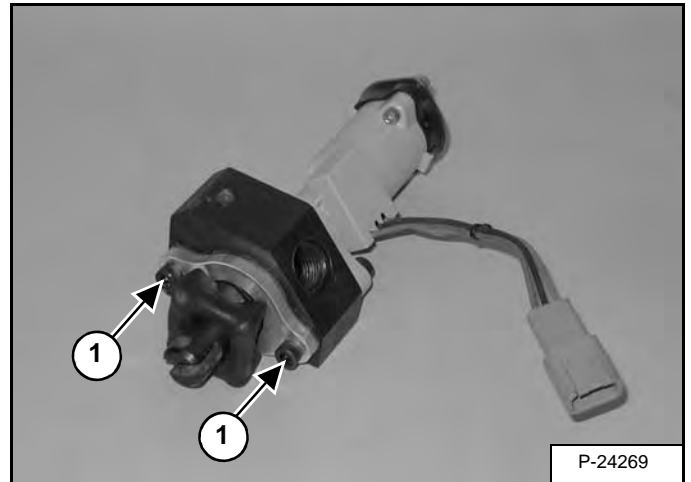

Remove the two bolts (Item 1) [Figure 60-130-28] from the end of the foot sensor.

Installation: Tighten the bolts to 90 in.-lb. (10,2 N•m) torque. Apply Loctite® #242 to the threads.

Figure 60-130-29

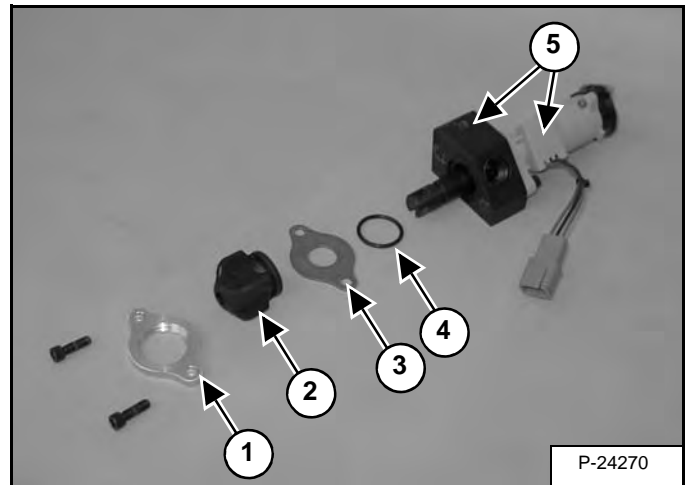

Remove the boot retainer (Item 1), boot (Item 2), spool stop plate (Item 3) and O-ring (Item 4) [Figure 60-130-29].

NOTE: Do not disassemble the sensor assembly (Item 5) [Figure 60-130-29]. The sensor assembly is a calibrated assembly and cannot be serviced. Order through Bobcat Parts.

CALIBRATION

Description

Calibration procedures must be followed when replacing a hydraulic control valve, actuator, Drive / Drive+ Controller, ACS Controller, pump controller, hydrostatic pump, or hydrostatic motor. Failure to calibrate after component replacement may result in poor performance or reduced life of actuator(s).

The **Actuator Test** is performed with the Service PC. The Actuator Test should be used if reduced performance codes are present or when replacing a controller or actuator.

NOTE: The Actuator Test should be used as the preferred method of actuator and valve spool calibration.

The **Lift and Tilt Calibration (ACS)** provides set points to the ACS controller to actuate the lift and tilt valve. The Lift and Tilt Calibration (ACS) should be used if reduced performance codes are present or when replacing a controller or actuator.

The **Lift and Tilt Calibration (SJC)** provides set points to the ACS controller to actuate the lift and tilt valve. The Lift and Tilt Calibration (SJC) should be used if reduced performance codes are present or when replacing a controller or actuator.

The **Hydrostatic Pump Calibration (SJC)** provides set points to the Drive controller to actuate the hydrostatic controller that directs flow to a servo piston. Hydrostatic Pump Calibration (SJC) should be performed when a desired travel path can not be attained or replacing the hydrostatic pump, hydrostatic motor, or controller. After Performing a Hydrostatic Pump Calibration (SJC), Steering Drift Compensation can be used to fine tune the hydrostatic pump control.

For more information on Steering Drift Compensation (See STEERING DRIFT COMPENSATION on Page 60-161-1.)

NOTE: The Actuator Test is the only test that uses a Service PC. The Lift and Tilt Calibration (ACS or SJC) does not need to be performed if the Actuator Testing is being performed with the Service PC. The Hydrostatic Pump Calibration does not need to be performed with the Actuator Test or Lift and Tilt Calibration (SJC).

Actuator Testing

Figure 60-160-1

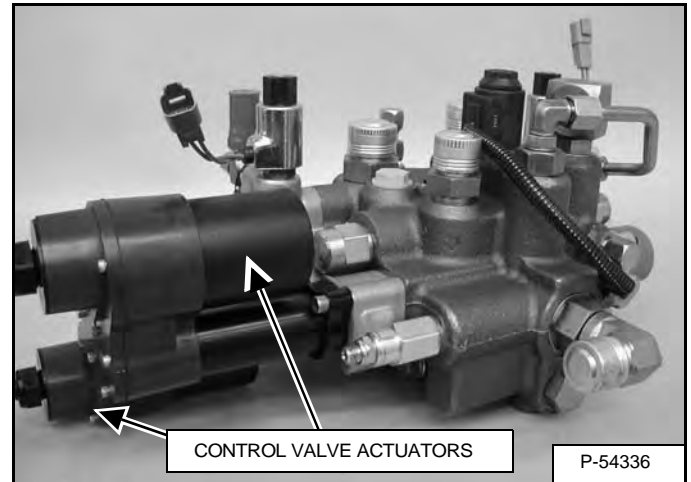

[Figure 60-160-1] Excessive actuator loading can occur if the actuator and valve spool components are misaligned. Misalignment may reduce spool stroke performance and reduce the life of the actuator. Starting with software version 36, the Bobcat Service Analyzer will be able to perform tests to diagnose actuator and valve spool misalignment.

Connect the Service PC (See SERVICE PC (LAPTOP COMPUTER) on Page 60-150-1.)

If a Service PC is not available, (See Lift And Tilt Calibration (SJC) on Page 60-160-4.) or (See Lift And Tilt Calibration (ACS) on Page 60-160-11.).

NOTE: Warm the hydraulic oil to room temperature 72°F (22°C), stop the engine and clear all active service codes before running the test.

Once the test is initiated, an automatic calibration sequence will start. When calibration is complete, the test will be performed and the results can be viewed on the Service PC (Laptop) monitor.

CALIBRATION (CONT'D)

Lift And Tilt Calibration (ACS)

The controller uses a calibration sequence to optimize the control system. The optimizing ensures full spool stroke (full flow) while preventing over stroke (loading) of the actuator and resets the calibration points in the controller.

NOTE: The Actuator Test is the preferred method to calibrate the lift and tilt actuator. (See Actuator Testing on Page 60-160-1.)

NOTE: This calibration procedure must be followed when replacing a hydraulic control valve, actuator or ACS controller. Failure to calibrate after component replacement may result in poor performance or reduced life of actuator(s).

Figure 60-160-22



Update the loader service software to the latest version.

Place the rocker switch (Item 1) [Figure 60-160-22] in the hand control mode.

Figure 60-160-23

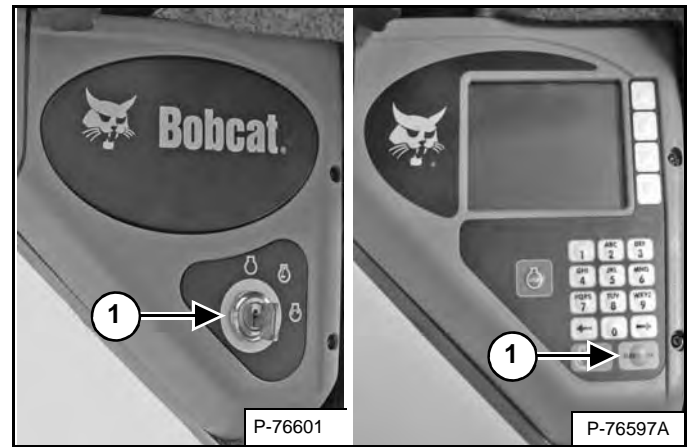

Close the cab door. (If loader is equipped.)

With the seat bar down, turn the ignition key ON (Deluxe Instrumentation Panel press RUN/ENTER) (Item 1) [Figure 60-160-23].

NOTE: Do not start the engine.

Figure 60-160-24

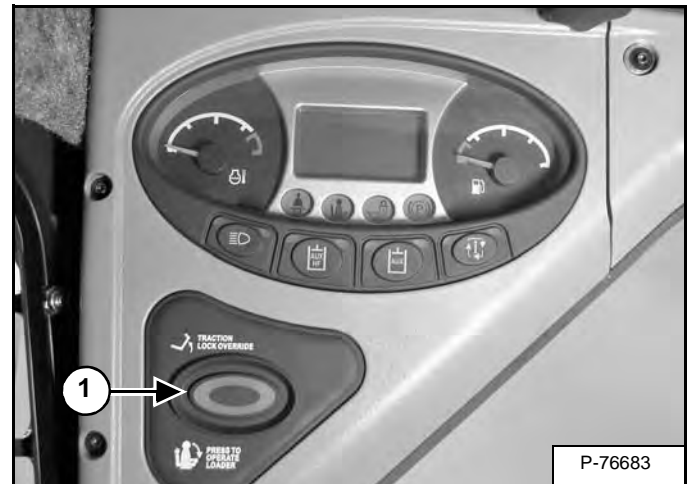

Push the PRESS TO OPERATE button (Item 1) [Figure 60-160-24] to unlock the hand controls.

MAINTENANCE CLOCK

Description

The Maintenance Clock alerts the operator when the next service interval is due. *EXAMPLE:* The Maintenance Clock can be set to a 250 hour interval as a reminder for the next 250 hour planned maintenance.

Figure 60-200-1

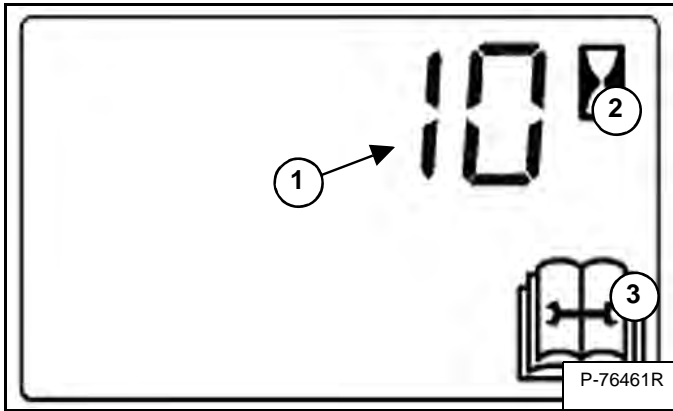

During machine operation, a two beep alarm will sound when there are less than 10 hours until the next planned maintenance.

The remaining hours before maintenance is required will appear in the data display (Item 1) while the service icon (Item 3) and hour meter icon (Item 2) [Figure 60-200-1] flash.

NOTE: The display will show negative numbers after counting down to zero.

The display will then revert back to the previous display and will appear every time the machine is started until the maintenance clock is reset.

Figure 60-200-2



The Deluxe Instrumentation Panel, if equipped, will display a message (Item 1) [Figure 60-200-2] alerting the operator to service the machine. This message will remain on the screen before reverting back to the previous screen and will appear every time the machine is started until the maintenance clock is reset.

Figure 60-200-3

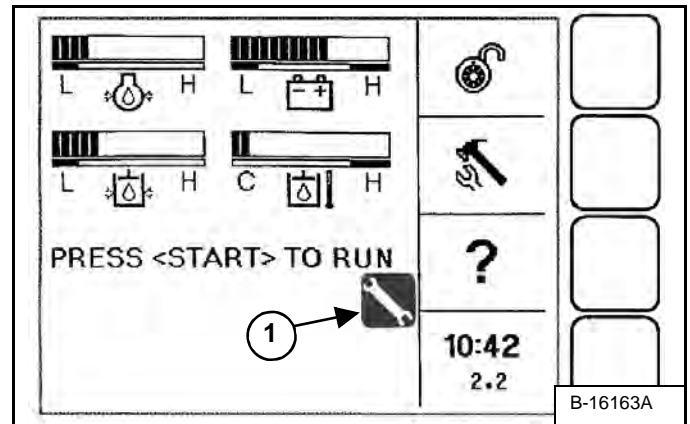

The Deluxe Instrumentation Panel, if equipped, will display a wrench icon (Item 1) [Figure 60-200-3] alerting the operator to service the machine. This icon will remain on the display until the maintenance clock is reset.

NOTE: Key Switch machines will not display the BobCARE PMSM message or wrench icon on the right panel.

BACK-UP ALARM SYSTEM (CONT'D)

Alarm Removal And Installation

Stop the engine and open the tailgate.

Figure 60-210-4

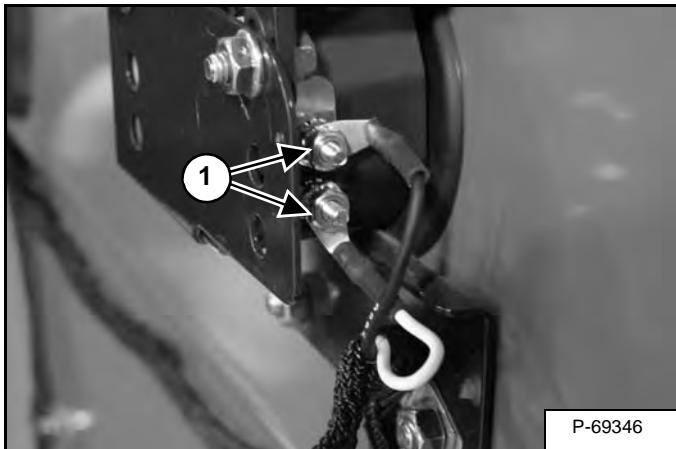

Mark the wires for ease of assembly. Disconnect the wires (Item 1) [Figure 60-210-4] from the alarm.

Installation: Make sure the wire harness ends do not touch the mounting bolts during assembly.

Figure 60-210-5

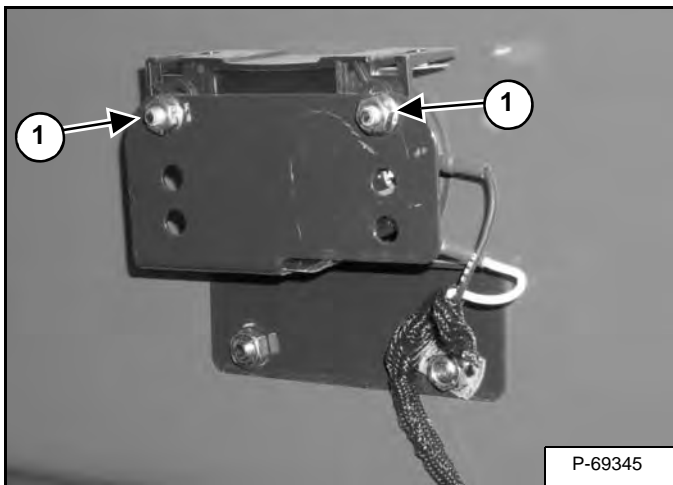

Remove the two hex head bolts, washers, and lock nuts (Item 1) [Figure 60-210-5]. Remove the alarm from the mounting bracket.

Switch Removal And Installation

NOTE: Joystick equipped machines do not have back-up alarm switches and can not be adjusted.

Standard Controls and ACS (If Equipped)

Stop the engine and raise the operator cab. (See Raising on Page 10-30-1.)

Figure 60-210-6

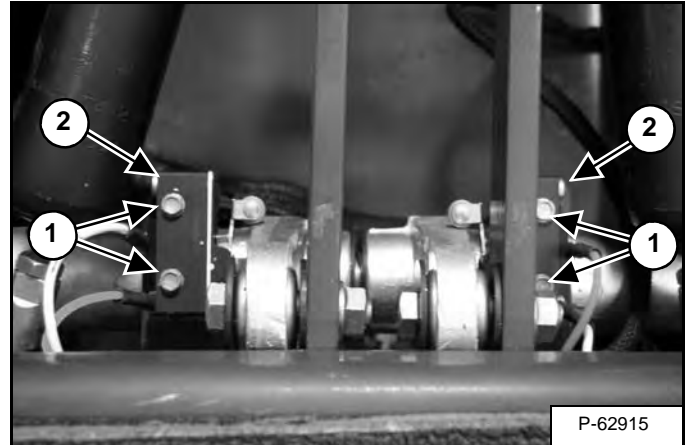

Place the steering levers in the neutral position.

Loosen the screws (Item 1) securing the back-up alarm switches. Slide the switch assemblies (Item 2) [Figure 60-210-6] off the mounting bracket.

Installation: Slide the alarm switches onto the mounting bracket so the threaded plates are under the mounting bracket. The rollers will face to the inside. During installation of switches, adjusting the switches (See Adjusting Switch Position on Page 60-210-2.) and inspecting back-up alarm operation (See Inspecting on Page 60-210-1.) are required.

ENGINE INFORMATION (CONT'D)

Specifications (Cont'd)

All dimensions are given in inches. Respective metric dimensions are given in millimeters enclosed by parentheses.

Cylinder Head

Cylinder Head Surface Flatness - Allowable Limit	0.0019 in. (0,05 mm)
Compression Pressure	503 PSI / 250 RPM (34,7 bar / 250 RPM)
Allowable Limit	371 PSI / 250 RPM (25,6 bar / 250 RPM)
Compression Ratio	19.0
Variance Among Cylinder - Allowable Limit	10% or less
Firing Order	1-3-4-2

Piston And Piston Ring

Piston Pin Bore I.D.	1.1811 - 1.1816 in. (30,000 - 30,013 mm)
Allowable Limit	1.1831 in. (30,05 mm)
Clearance Between Compression Ring 1 and Ring Groove	0.0020 - 0.0028 in. (0,05 - 0,07 mm)
Allowable Limit	0.0059 in. (0,15 mm)
Clearance Between Compression Ring 2 and Ring Groove	0.0037 - 0.0047 in. (0,093 - 0,120 mm)
Allowable Limit	0.0079 in. (0,20 mm)
Clearance Between Oil Ring And Ring Groove	0.0008 - 0.0023 in. (0,02 - 0,06 mm)
Allowable Limit	0.0059 in. (0,15 mm)
Ring Gap	
Compression Ring 1	0.0118 - 0.0177 in. (0,30 - 0,45 mm)
Allowable Limit	0.0492 in. (1,25 mm)
Compression Ring 2	0.0118 - 0.0177 in. (0,30 - 0,45 mm)
Allowable Limit	0.0492 in. (1,25 mm)
Oil Ring	0.0098 - 0.0177 in. (0,25 - 0,45 mm)
Allowable Limit	0.0492 in. (1,25 mm)

Connecting Rod

Connecting Rod Alignment - Allowable Limit	0.0020 in. (0,05 mm)
Clearance Between Piston Pin And Small End Bushing	0.0008 - 0.0016 in. (0,02 - 0,040 mm)
Allowable Limit	0.0059 in. (0,15 mm)
Piston Pin O.D.	1.1813 - 1.1815 in. (30,006 - 30,011 mm)
Small End Busing I.D.	1.1823 - 1.1829 in. (30,031 - 30,046 mm)

Cylinder Bore

Cylinder Bore I.D.	3.9370 - 3.9379 in. (100,000 - 100,022 mm)
Allowable Limit	3.9429 in. (100,15 mm)
Oversized Cylinder Liner I.D.	3.9567 - 3.9576 in. (100,500 - 100,522 mm)
Allowable Limit	3.9626 in. (100,65 mm)

ENGINE INFORMATION (CONT'D)

Engine Removal And Installation (Cont'd)

Figure 70-10-24

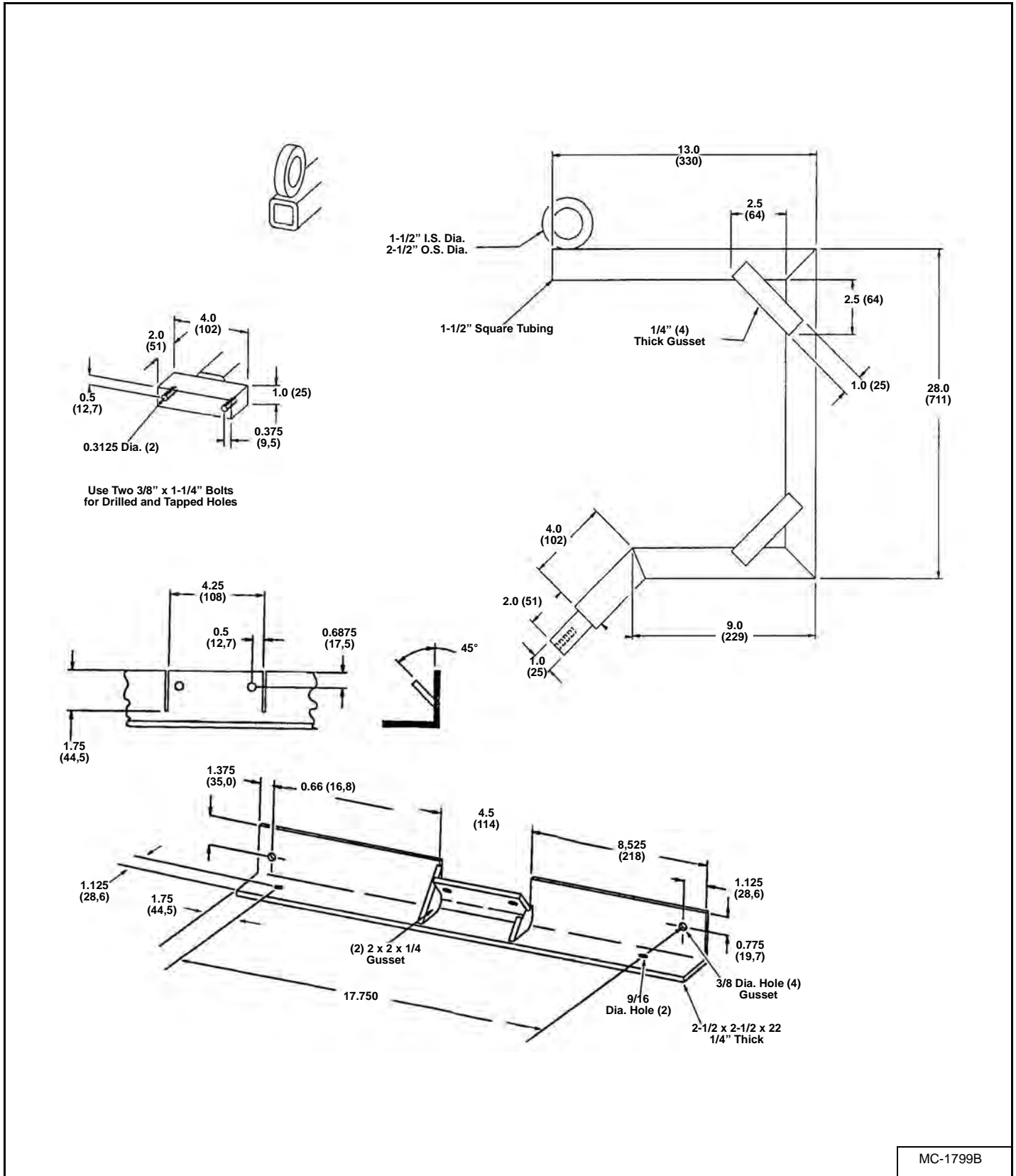

MC-1799B

ENGINE SPEED CONTROL (SJC) (CONT'D)

Removal And Installation (Cont'd)

Figure 70-21-9

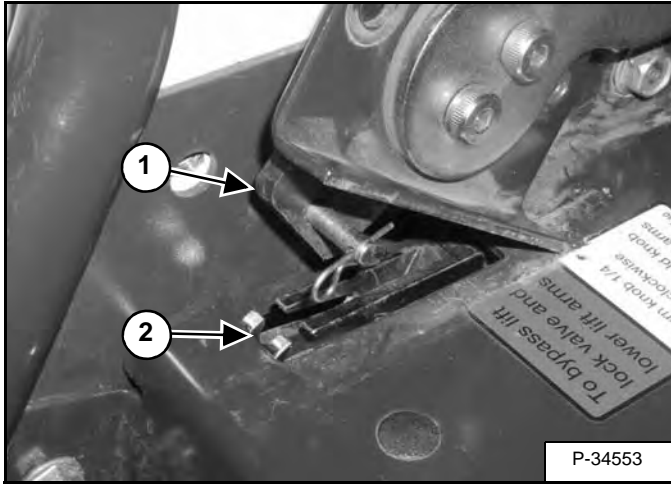

Installation: When installing the hand speed control to the speed control cable, be sure the speed control lever (Item 1) fits in the notch (Item 2) [Figure 70-21-9] of the speed control cable clevis.

Disassembly And Assembly

Figure 70-21-10

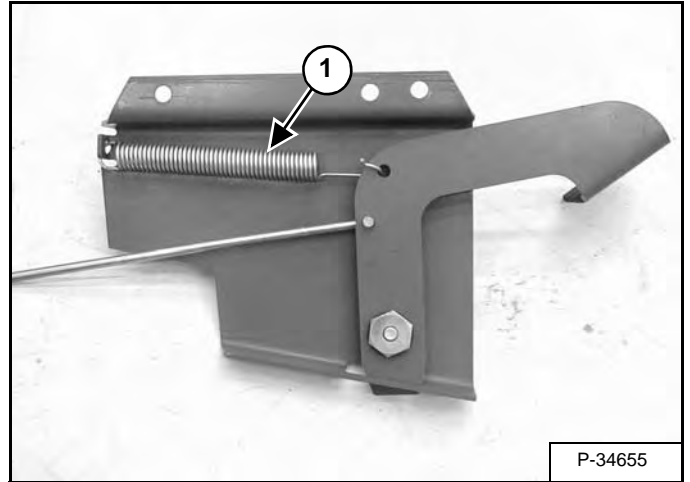

Remove the spring (Item 1) [Figure 70-21-10] from the foot speed control assembly.

Figure 70-21-11

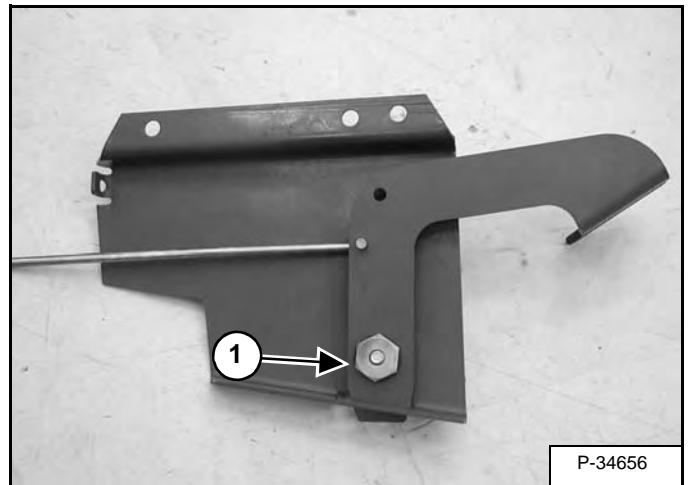

Remove the bushing/nut (Item 1) [Figure 70-21-11] from the pedal lever.

ENGINE COOLING SYSTEM (CONT'D)

Radiator Removal And Installation (Cont'd)

Figure 70-50-9

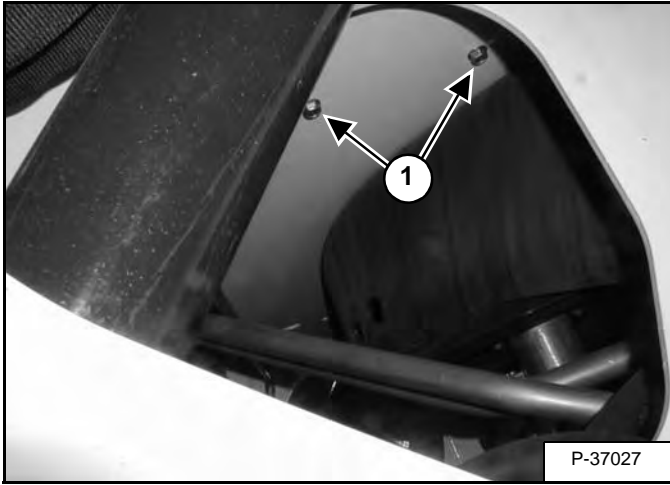

At the right side access hole, remove the two radiator mount bolts (Item 1) [Figure 70-50-9].

Remove the radiator and mount assembly from the loader.

Radiator Mount Removal And Installation

Figure 70-50-10

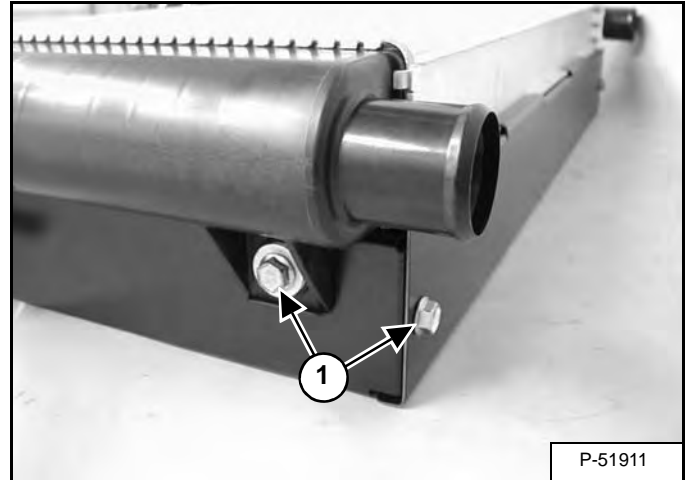

Remove the two mounting bolts (Item 1) [Figure 70-50-10] from the radiator and radiator mount bracket.

Installation: Tighten the bolts to 7.5 - 11.5 ft.-lb. (10,1 - 15,5 N•m) torque.

Figure 70-50-11

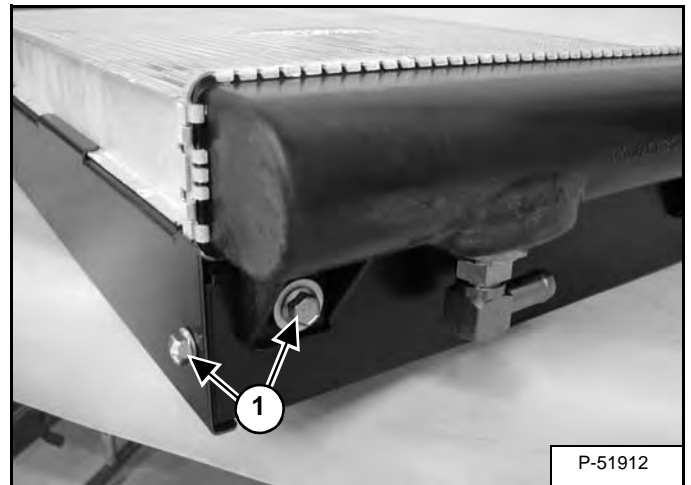

Remove the two mounting bolts (Item 1) [Figure 70-50-11] from the radiator and radiator mount bracket.

Installation: Tighten the bolts to 7.5 - 11.5 ft.-lb. (10,1 - 15,5 N•m) torque.

LUBRICATION SYSTEM

Oil Pan Removal And Installation

Remove the engine/hydrostatic pump package from the loader. (See Engine Removal And Installation on Page 70-10-10.)

Figure 70-60-1

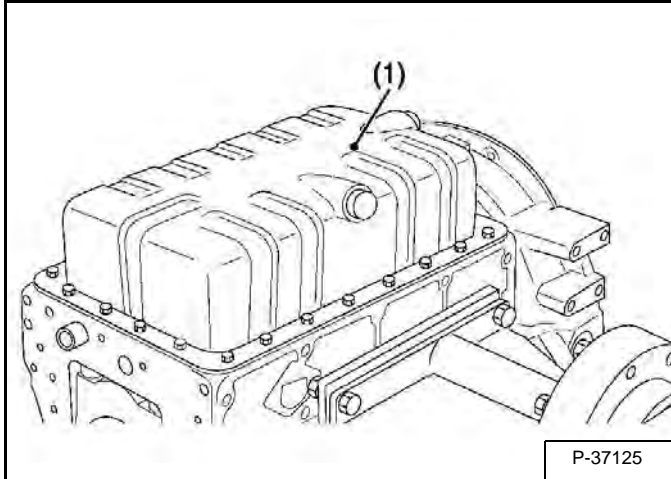

Unscrew the oil pan mounting screws and remove the oil pan (Item 1) [Figure 70-60-1].

Figure 70-60-2

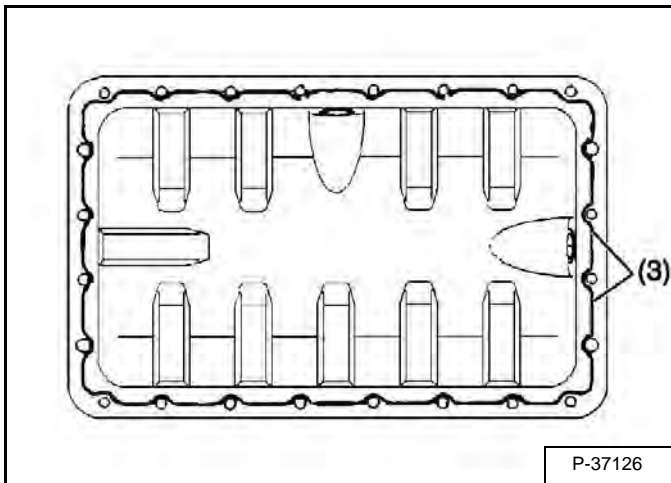
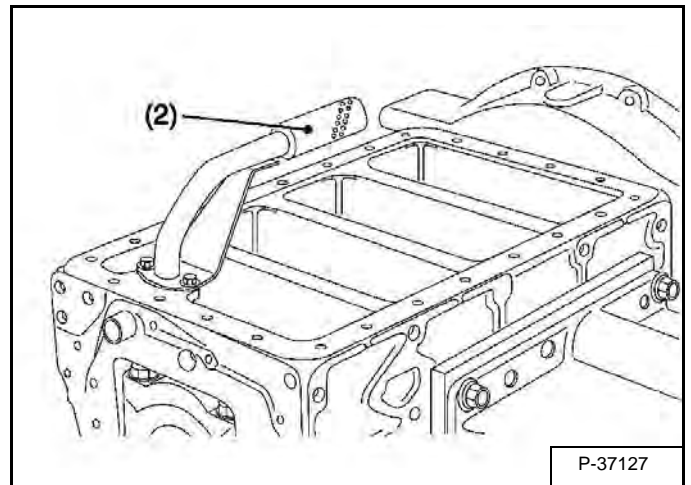

Figure 70-60-3



Unscrew the oil strainer mounting screw, and remove the oil strainer (Item 2) [Figure 70-60-3].

Install the oil strainer, using care not to damage the O-ring.

Apply liquid gasket to the oil pan (Item 3) [Figure 70-60-2].

Confirm that the liquid gasket coating surface is free of water, dust and oil in order to maintain sealing effect.

Carefully apply the adhesive evenly.

NOTE: When mounting the adhesive-applied parts, take care to fit them to the mating parts. Assemble the adhesive-applied parts within ten minutes.

To avoid uneven tightening, tighten mounting screws in diagonal order from the center. After cleaning the oil strainer, install it. Attach the oil pan with its central drain plug facing toward the air suction side.

FUEL SYSTEM (CONT'D)

Fuel Injection Pump Assembly Installation

Set the number four cylinder to T.D.C. (See Valve Timing - Checking on Page 70-80-4.)

Figure 70-70-15

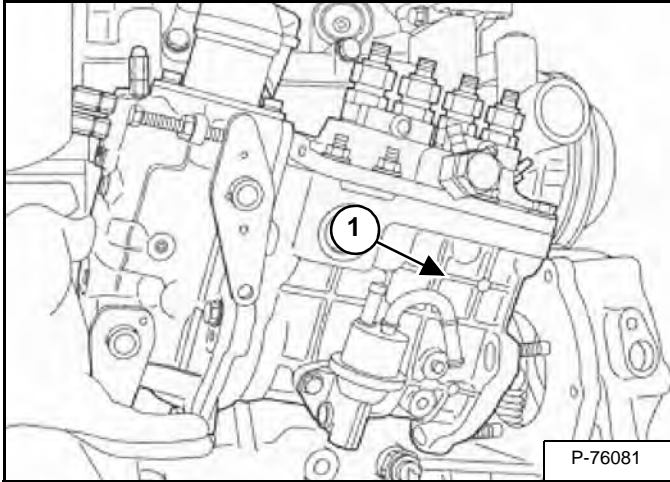

Install the injection pump unit into the engine (Item 1) [Figure 70-70-15].

Do not tighten the assembly at this point.

Figure 70-70-16

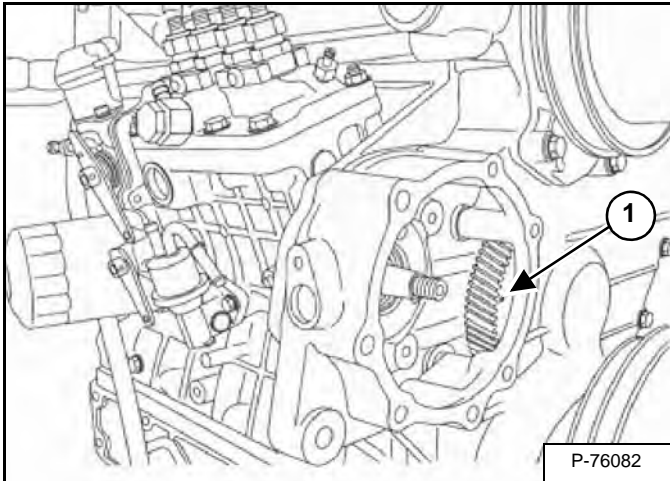

Make sure the alignment mark on the idler gear is in position (Item 1) [Figure 70-70-16].

Figure 70-70-17

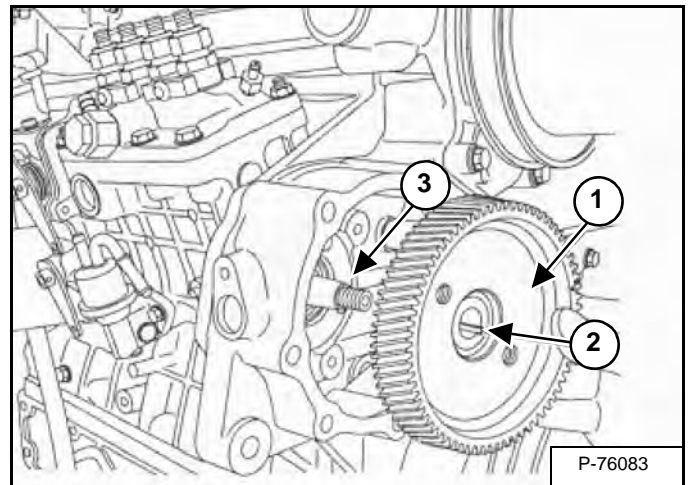

Install the injection pump gear (Item 1) [Figure 70-70-17] to the injection pump assembly while aligning the two marks (Item 2) [Figure 70-70-18] of the injection pump gear and idler gear.

NOTE: Make sure the key (Item 3) is fit in the keyway (Item 2) [Figure 70-70-17] of the injection pump gear.

Figure 70-70-18

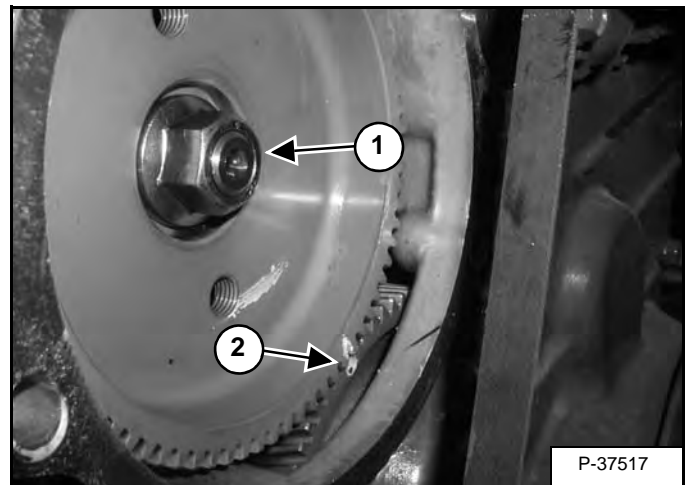

Tighten the injection pump gear nut (Item 1) [Figure 70-70-18] to 54 - 62 ft.-lb. (74 - 83 N•m) torque.

FUEL SYSTEM (CONT'D)

Fuel Injection Pump Removal (Cont'd)

Figure 70-70-47

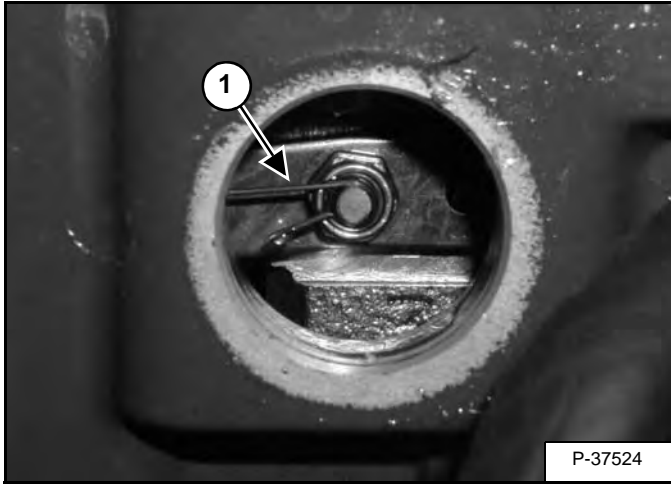

Disconnect the starter spring hook (Item 1) [Figure 70-70-47].

NOTE: Be careful to not deform the starter spring.

Figure 70-70-48

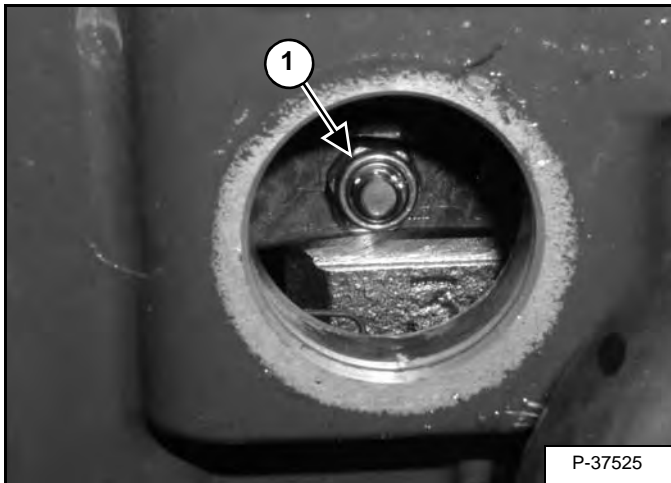

Remove the control rod nut (Item 1) [Figure 70-70-48].

NOTE: Be careful not to drop the control rod nut.

Installation: Tighten the control rod nut to 24 - 36 in.-lb. (3 - 4 N•m) torque.

Figure 70-70-49

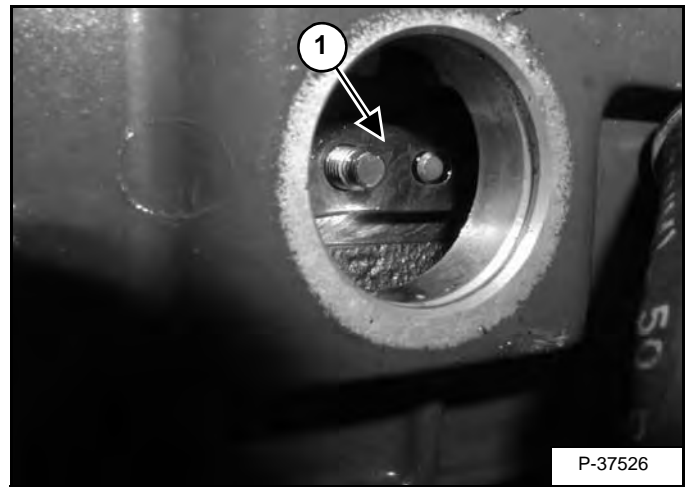

Disconnect the control rod (Item 1) [Figure 70-70-49] from the injection pump.

Figure 70-70-50

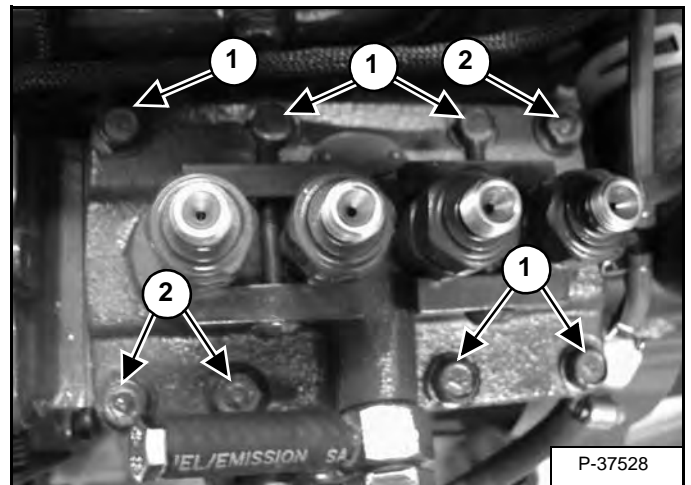

Remove the five injection pump mounting bolts (Item 1) [Figure 70-70-50].

Remove the three injection pump mounting nuts (Item 2) [Figure 70-70-50].

Installation: Tighten the injection pump mounting bolts to 17 - 20 ft.-lb. (24 - 28 N•m) torque. Tighten the injection pump mounting nuts to 13 - 15 ft.-lb. (18 - 21 N•m) torque.

FUEL SYSTEM (CONT'D)

Nozzle Spraying Condition

Figure 70-70-84

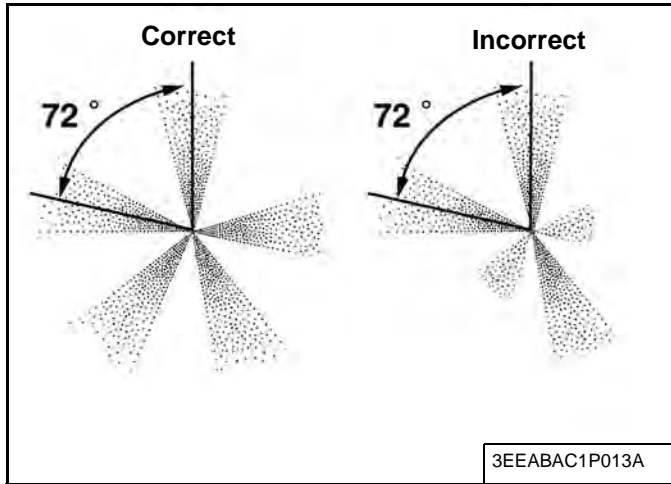

Set the injection nozzle to a nozzle tester (Code No. 07909-31361), and check the nozzle spraying condition.

If the spraying condition is defective, replace the injection nozzle assembly or repair at Denso service shop.

Valve Seat Tightness

Figure 70-70-85

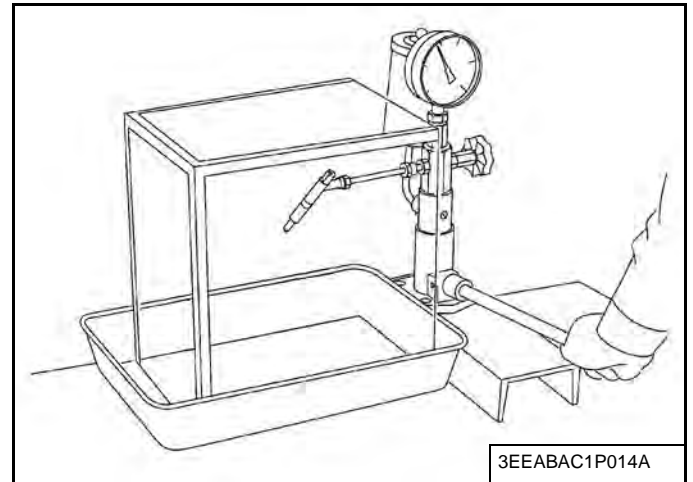

Set the injection nozzle to a nozzle tester (Code No. 07909-31361).

Raise the fuel pressure, and keep at 2418 PSI (166,7 bar) for 10 seconds.

If any fuel leak is found, replace the injection nozzle assembly or repair at Denso service Shop.

Valve seat tightness	Factory spec.	No fuel leak at 2418 PSI (166,7 bar)
----------------------	---------------	--------------------------------------

CYLINDER HEAD (CONT'D)

Cylinder Head Top Clearance

Select the suitable cylinder head gasket refer to the table below.

Notch of Cylinder Head Gasket	Thickness of cylinder head gasket		Part Code	Piston Head's recessing or protrusion from the level of crankcase cylinder face. (average of 4 pistons)
	Before tightening	After tightening		
2 notches (a)	0.0354 in. (0,90 mm)	0.0315 in. (0,80 mm)	1G514 - 03310	-0.0028 - +0.0019 in. (-0,07 - +0,0490 mm)
1 notch (b)	0.0394 in. (1,00 mm)	0.0354 in. (0,90 mm)	1G514-03600	+0.0020 - +0.0058 in. (+0,050 - +0,149 mm)
Without notch (c)	0.0413 in. (1,05 mm)	0.0374 in. (0,95 mm)	1G514-03610	+0.0059 - +0.0078 in. (+0,150 - +0,20 mm)

CRANKSHAFT AND PISTONS (CONT'D)

Piston And Connecting Rod - Servicing

The Small End Bushing Replacing Tool can be made using the dimensions below. One set of dimensions is for the press out tool and one for press fit.

Figure 70-90-6

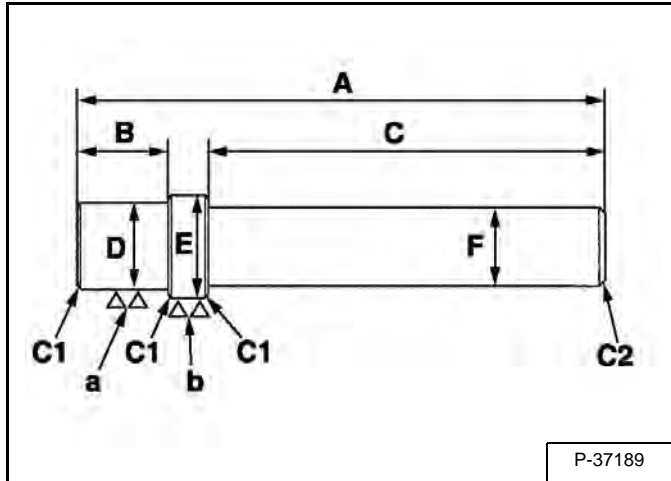

Small End Bushing Replacing Tool

Application: Use to press out and to press fit the small end bushing in the connection rod.

(Press out)

A	6.181 in. (157 mm dia.)
B	0.571 in. (14,5 mm)
C	4.7244 in. (120 mm)
D	1.1851 - 1.187 in. dia. (30,101 - 30,156 mm dia.)
E	1.3021 - 1.3031 in. dia. (33,075 - 33,100 mm dia.)
F	0.7874 in. (20 mm)
a	0.00025 in. (0,0000063 mm)
b	0.00025 in. (0,0000063 mm)
C1	Chamfer 0.039 in. (1,0 mm)
C2	Chamfer 0.079 in. (2,0 mm)

(Press fit)

A	6.181 in. (157 mm dia.)
B	0.571 in. (14,5 mm)
C	4.7244 in. (120 mm)
D	1.1851 - 1.187 in. dia. (30,101 - 30,156 mm dia.)
E	1.6535 in. dia. (42,000 mm dia.)
F	0.7874 in. (20 mm)
a	0.00025 in. (0,0000063 mm)
b	0.00025 in. (0,0000063 mm)
C1	Chamfer 0.039 in. (1,0 mm)
C2	Chamfer 0.079 in. (2,0 mm)

CRANKSHAFT AND PISTONS (CONT'D)

Crankshaft And Bearings Installation (Cont'd)

Figure 70-90-32

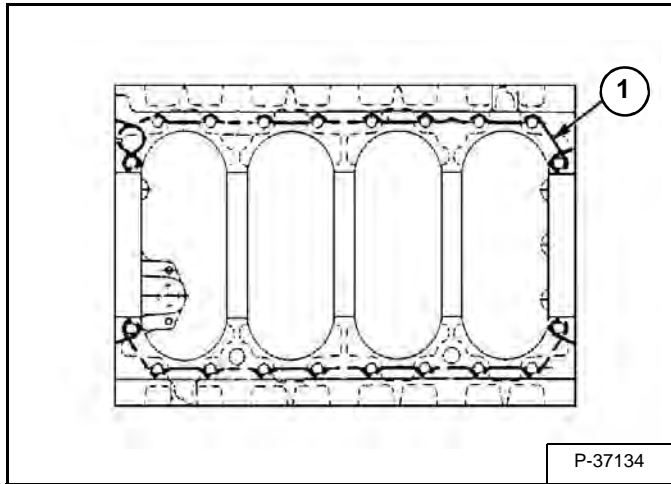

NOTE: Make sure the crankcase 1 and 2 are clean. Apply liquid gasket (Item 1) [Figure 70-90-32] to the crankcase 2 as shown in the figure.

Tighten the crankcase 2 mounting screws with even force on the diagonal line. Confirm that the liquid gasket coating surface is free of water, dust and oil in order to maintain sealing effect. Carefully apply the adhesive evenly.

Figure 70-90-33

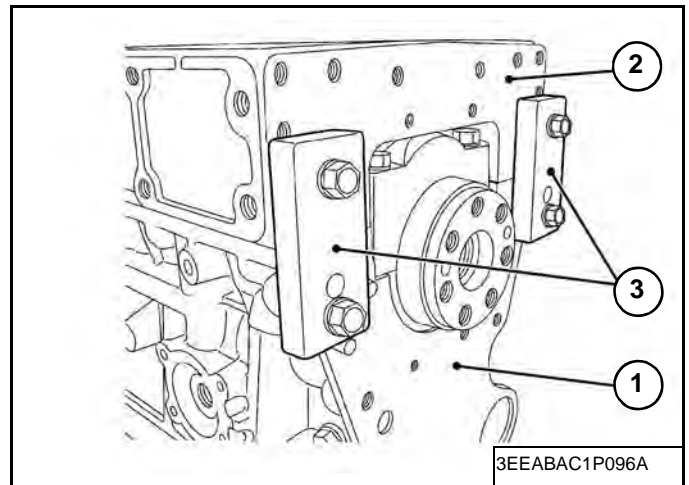

Match the crankcase 1 (Item 1) and crankcase 2 (Item 2), [Figure 70-90-33] referring to the flywheel's contoured face.

Tighten the crankcase 2 mounting bolts loosely.

Install the jig (Item 3) [Figure 70-90-33] to the specified torque, same as the flywheel housing screw. This helps to minimize the level difference between the crankcase 1 and the crankcase 2 (at the flywheel side). Possible gap must be 0.002 in. (0,05 mm) or smaller.

Tightening torque	Flywheel housing screw	57.1 - 66.5 ft.-lb. (77,5 - 90,2 N•m)
-------------------	------------------------	--

CAMSHAFT AND TIMING GEARS (CONT'D)

Camshaft - Servicing

Side Clearance

Figure 70-100-8

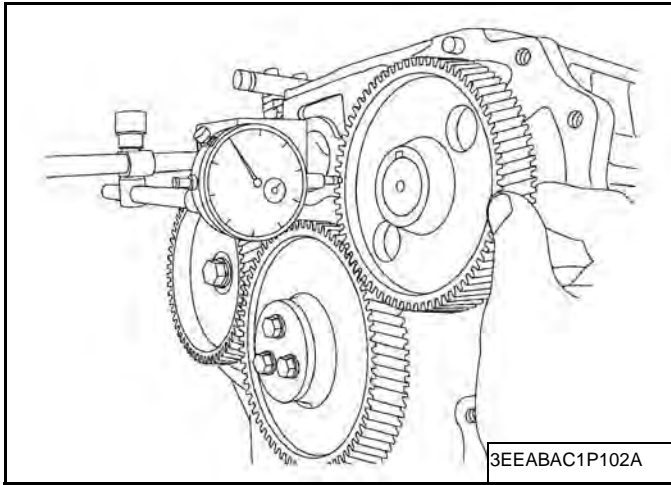

Set a dial indicator with its tip on the camshaft **[Figure 70-100-8]**.

Measure the side clearance by moving the cam gear to the front and rear.

If the measurement exceeds the allowable limit, replace the camshaft stopper.

Side clearance	Factory spec.	0.0028 - 0.0087 in. (0,07 - 0,22 mm)
	Allowable limit	0.0118 in. (0,03 mm)

Alignment

Figure 70-100-9

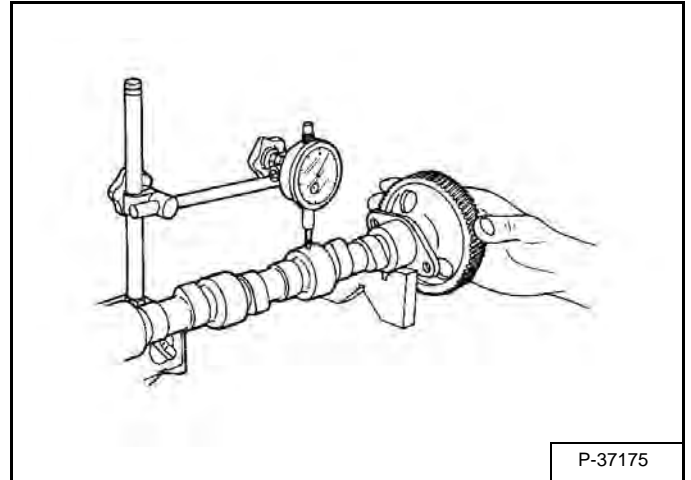

Support the camshaft with V block on the surface plate and set a dial indicator with its tip on the intermediate journal at right angle **[Figure 70-100-9]**.

Rotate the camshaft on the V blocks and get the misalignment (half of the measurement).

If the misalignment exceeds the allowable limit, replace the camshaft.

Camshaft alignment	Allowable limit	0.00039 in. (0,01 mm)
--------------------	-----------------	--------------------------

HEATING, VENTILATION, AIR CONDITIONING

AIR CONDITIONING SYSTEM FLOW	80-10-2
Chart	80-10-3
Components.	80-10-4
Description.	80-10-2
Safety Equipment.	80-10-7
BLOWER FAN.	80-130-1
Connector Identification	80-130-4
Disassembly And Assembly.	80-130-2
Removal And Installation	80-130-1
COMPRESSOR	80-50-1
Clutch Disassembly And Assembly	80-50-4
Oil.	80-50-2
Oil Check.	80-50-3
Removal And Installation	80-50-1
CONDENSER	80-60-1
Removal And Installation	80-60-1
EVAPORATOR COIL.	80-110-1
Removal And Installation	80-110-1
EVAPORATOR / HEATER UNIT	80-80-1
Removal And Installation	80-80-1
EXPANSION VALVE	80-100-1
Removal And Installation	80-100-1
HEATER COIL.	80-120-1
Removal And Installation With A/C	80-120-1
Removal And Installation Without A/C.	80-120-3
HEATER VALVE	80-140-1
Disassembly And Assembly.	80-140-2
Removal and Installation	80-140-1
RECEIVER / DRIER	80-70-1
Pressure Relief Valve Removal And Installation	80-70-2
Pressure Switch Removal And Installation	80-70-3
Receiver / Drier Removal And Installation	80-70-1
Schraeder Valve Removal And Installation	80-70-3

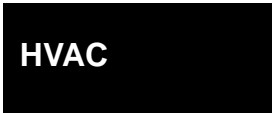

Continued On Next Page

REGULAR MAINTENANCE

Filters

Figure 80-20-1

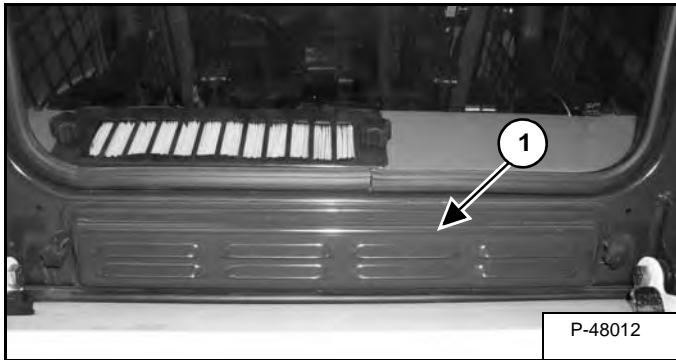

The *Fresh Air Filter* (Item 1) [Figure 80-20-1] is located below the rear window outside the cab. Remove the clamping knobs, filter cover and filter.

Shake the filter or use low pressure air to remove dirt. This can be done several times before replacement is required. Install the filter, filter cover and clamping knobs.

Figure 80-20-2

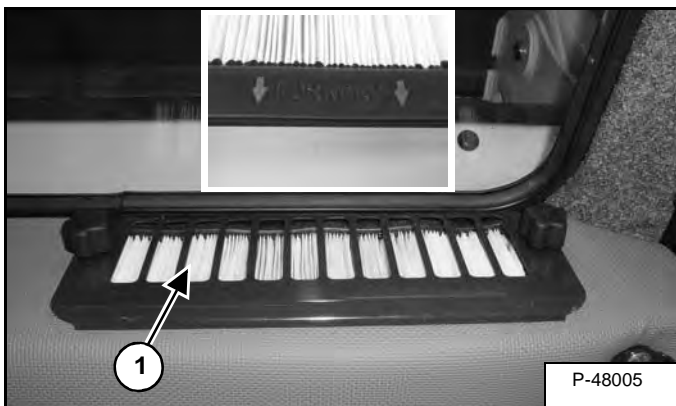

The *Recirculation Filter* (Item 2) [Figure 80-20-2] is located in front of the rear window inside the cab. Remove the clamping knobs, filter cover, and filter.

Shake the filter or use a vacuum to clean. This can be done several times before replacement is required. Install the filter with the arrows pointing forward (Inset) [Figure 80-20-2], install the filter cover and clamping knobs.

TROUBLESHOOTING (CONT'D)

Troubleshooting Tree (Cont'd)

Air Conditioning

Continued on previous page.

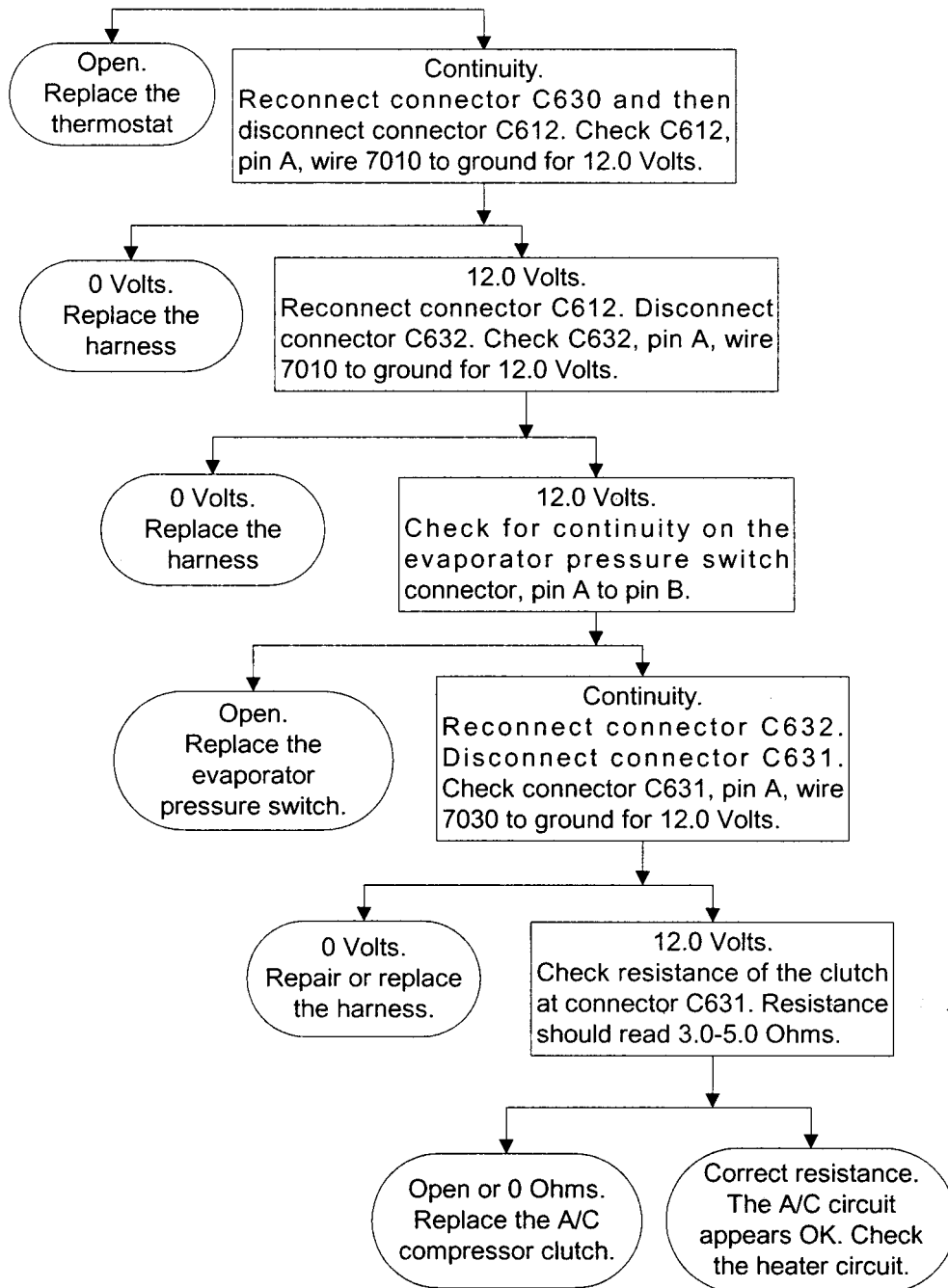

TROUBLESHOOTING (CONT'D)

Electrical System (Cont'd)

Figure 80-30-16

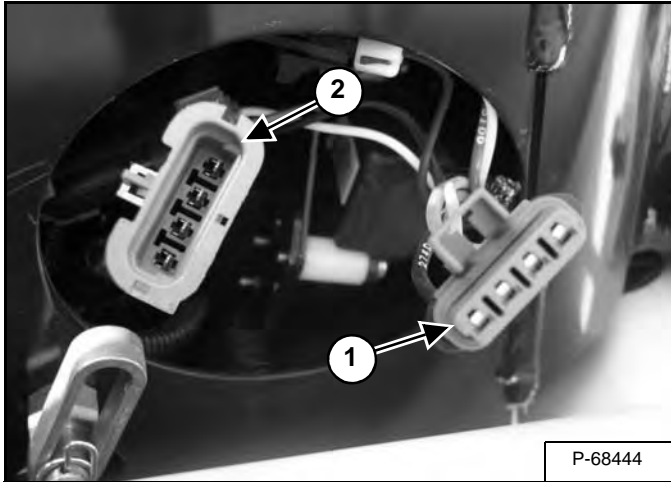

Check the loader harness (Item 1) [Figure 80-30-16] for voltage. The voltage should be 12 volts.

If there is no voltage at the wiring harness, check the harness for broken wires.

If there is voltage at the wiring harness, check the resistance to the blower at the blower wiring connector (Item 2) [Figure 80-30-16].

If there is no resistance value replace the blower. (See Removal And Installation on Page 80-130-1.)

If there is a resistance value check the climate controls at the control panel inside the loader cab.

Figure 80-30-17

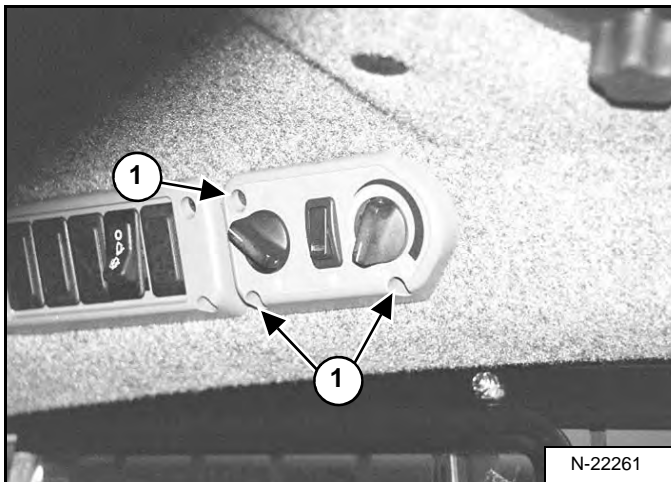

Remove the three mount bolts (Item 1) [Figure 80-30-17] from the cab control panel.

Figure 80-30-18



Remove the control panel and wiring harness from the cab [Figure 80-30-18].

Figure 80-30-19

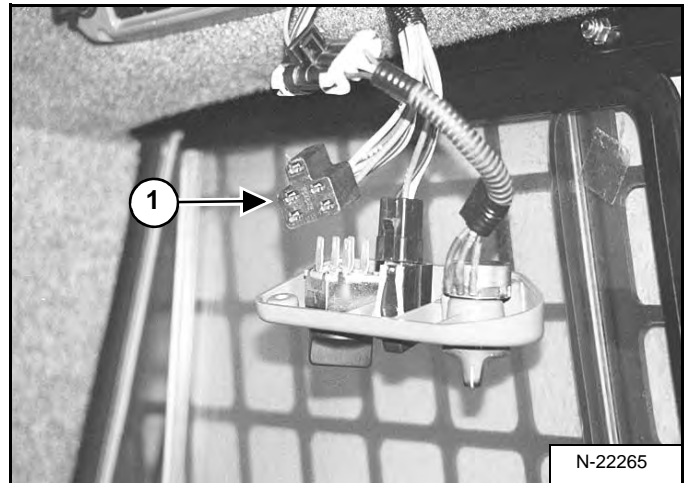

Disconnect the loader wiring harness (Item 1) [Figure 80-30-19] from the blower switch.

Check the loader harness for voltage. The voltage should be 12 volts.

If there is no voltage at the wiring harness, check the harness for broken wires.

SYSTEM CHARGING AND RECLAMATION (CONT'D)

Charging With A Manifold Gauge Set (Cont'd)

Figure 80-40-11

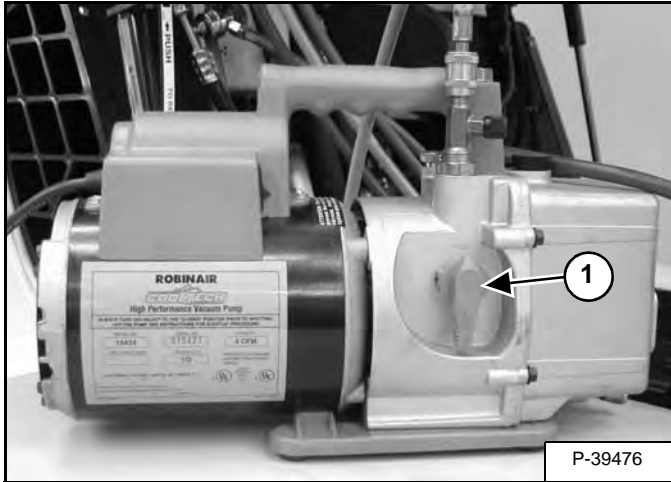

Start the vacuum pump and open Iso-valve (Item 1) [Figure 80-40-11] on the vacuum pump.

Run the vacuum pump for at least 5-10 minutes to insure that a vacuum has been pulled on the system.

Close the Iso-valve (Item 1) [Figure 80-40-11] (which isolates the vacuum pump from the A/C system) and turn OFF the vacuum pump.

Figure 80-40-12

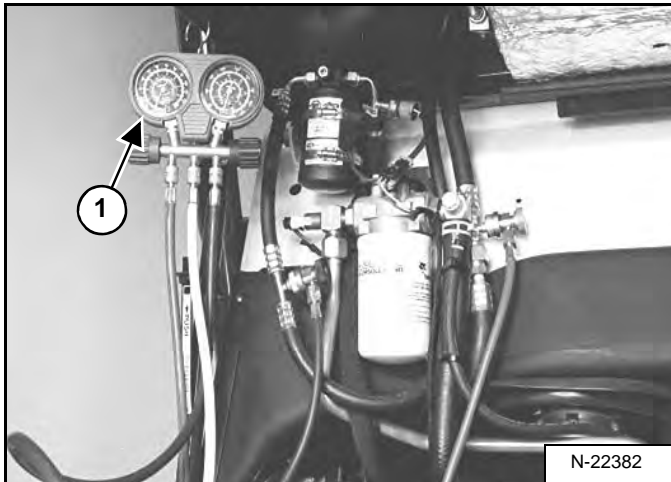

Note vacuum pressure indicated on the low pressure (Blue) gauge (Item 1) [Figure 80-40-12]. Let stand for 5-10 min. and recheck the pressure for changes.

If the pressure drops, this may be an indication of a leak in the A/C system.

Determine the problem with the A/C system and repair it.

Figure 80-40-13

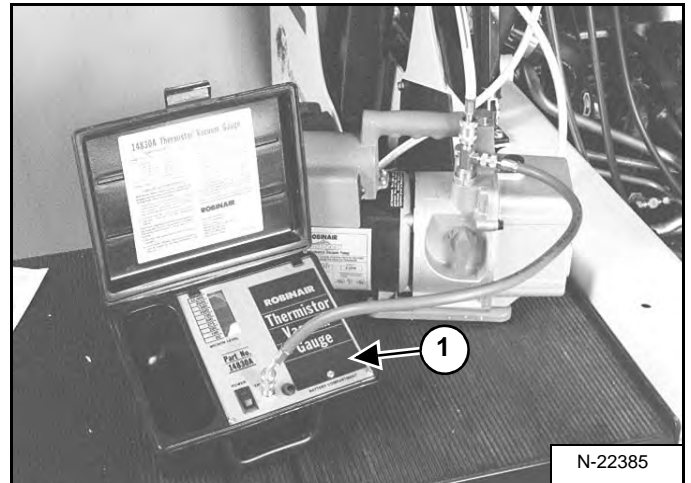

A thermistor vacuum gauge (Item 1) [Figure 80-40-13] may be necessary to use to determine the critical vacuum level during evacuation. It is a solid state instrument that constantly monitors and visually indicates the vacuum level.

The thermistor vacuum gauge is used with the vacuum pump [Figure 80-40-13].

Start the vacuum pump and open Iso-valve on the vacuum pump.

Be sure that both hand valves, and both charge port valves are open.

Run the vacuum pump for at least 45 minutes to insure that all the moisture is boiled out of the system.

Stop the vacuum pump and close the Iso-valve on the vacuum pump.

Close both hand valves on the manifold gauge set and remove the yellow hose from the vacuum pump that goes to the manifold gauge set.

Remove the vacuum pump and thermistor vacuum gauge.

CONDENSER

Removal And Installation

Remove the refrigerant from the A/C system. (See Reclamation And Charging With Recovery / Charging Unit on Page 80-40-2.)

Open the rear door of the loader.

Remove the rear grill from the loader. (See Removal And Installation on Page 50-60-1.)

Figure 80-60-1

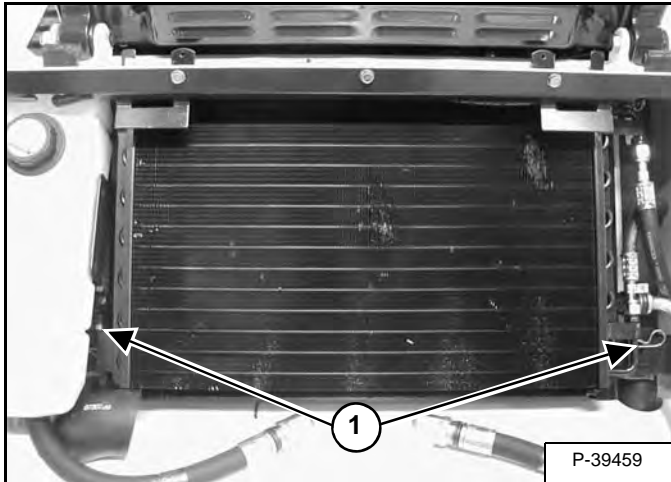

Remove the two retaining clips (Item 1) [Figure 80-60-1] from the condenser mount bracket.

Figure 80-60-2

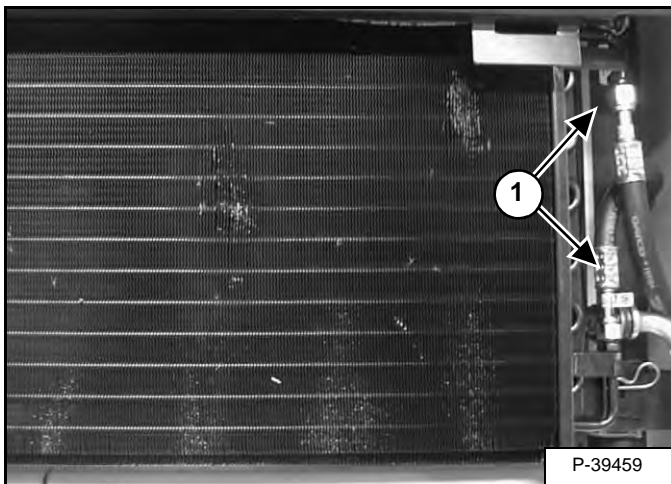

Mark the two A/C hoses (Item 1) [Figure 80-60-2] for proper installation.

Disconnect the two hoses from the condenser.

Cap and plug the hoses and the condenser fittings with the proper A/C caps and plugs.

Figure 80-60-3

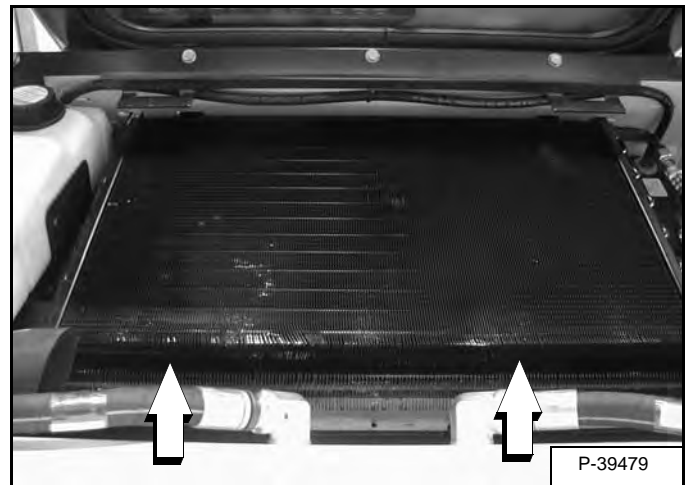

Lift the rear of the condenser, and pull toward the rear of the loader [Figure 80-60-3].

Remove the condenser from the loader.

Figure 80-60-4

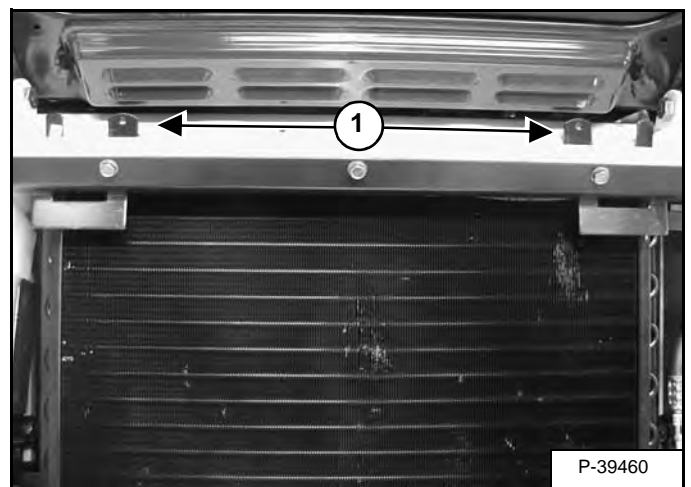

Installation: When installing the condenser, be sure the condenser tabs (Item 1) [Figure 80-60-4] are positioned in the slots in the loader frame.

EXPANSION VALVE

Removal And Installation

NOTE: The expansion valve can be changed without removing the evaporator/heater unit from the loader.

Raise the lift arms and install an approved lift arm support device. (See Installing on Page 10-20-1.)

Raise the operator cab. (See Raising on Page 10-30-1.)

Evacuate the A/C system. (See Reclamation And Charging With Recovery / Charging Unit on Page 80-40-2.)

Figure 80-100-1

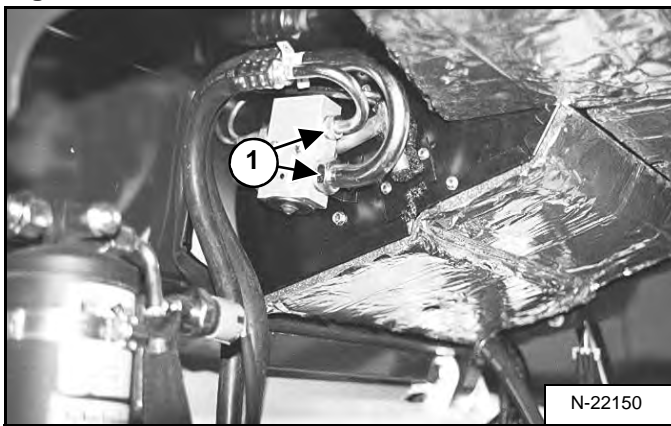

Remove the two A/C hoses (Item 1) [Figure 80-100-1] from the expansion valve.

Installation: Tighten the two A/C hose fittings to 22 ft.-lb. (29,8 N•m) torque.

Cap and plug the hoses and the expansion valve fittings with the proper A/C caps and plugs.

Figure 80-100-2

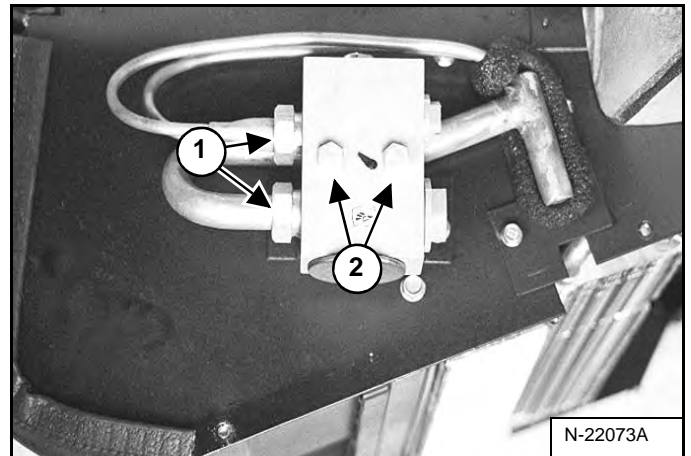

Remove the two evaporator fittings (Item 1) [Figure 80-100-2] from the expansion valve.

Installation: Tighten the two evaporator fittings to 22 ft.-lb. (29,8 N•m) torque.

Remove the two mount bolts (Item 2) [Figure 80-100-2].

Remove the expansion valve from the loader.

Figure 80-100-3

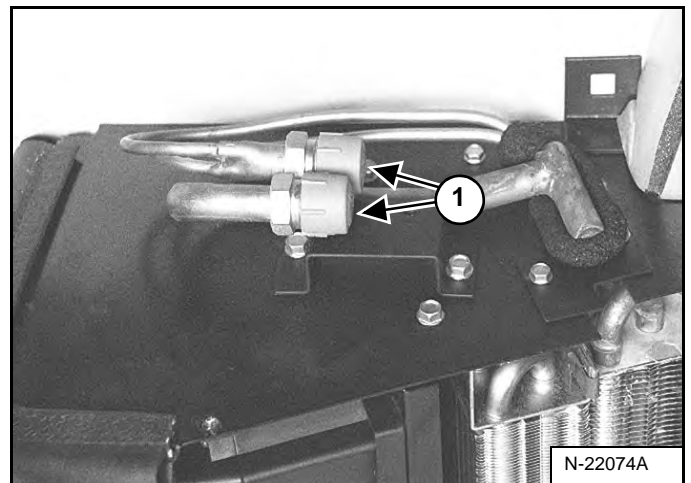

Check the condition of the o-rings and replace as needed. Cap and plug the evaporator tubelines (Item 1) [Figure 80-100-3] and the expansion valve fittings with the proper A/C caps and plugs.

BLOWER FAN (CONT'D)

Disassembly And Assembly (Cont'd)

Figure 80-130-9

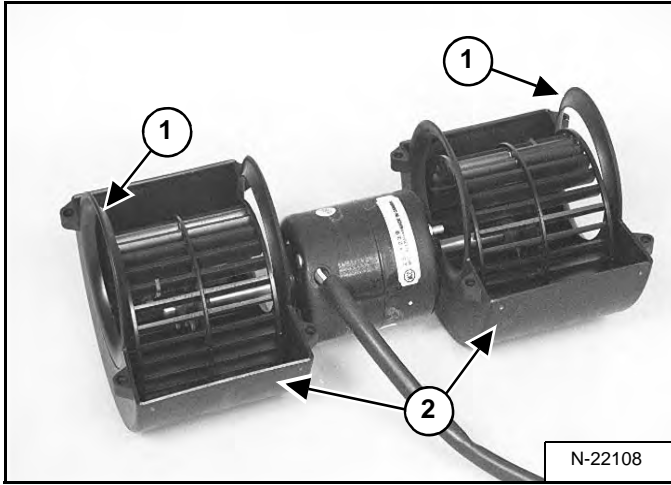

Remove the outside rings (Item 1) and blower wheel covers (Item 2) [Figure 80-130-9] from the blower motor and blower wheels.

Figure 80-130-10

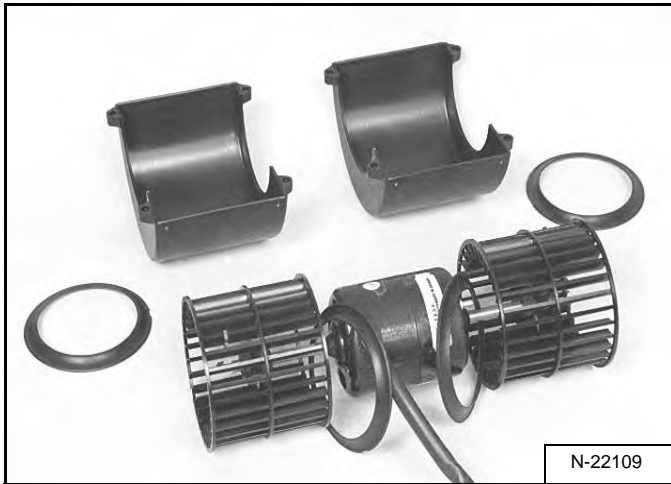

Inspect the end rings and blower wheel covers for wear and replace as needed [Figure 80-130-10].

Figure 80-130-11

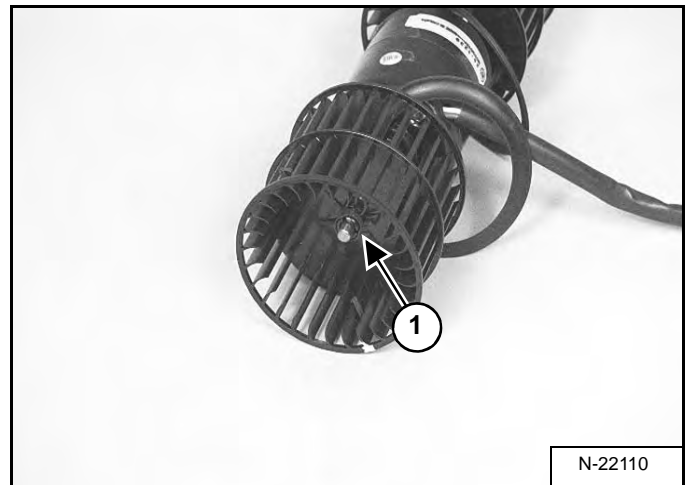
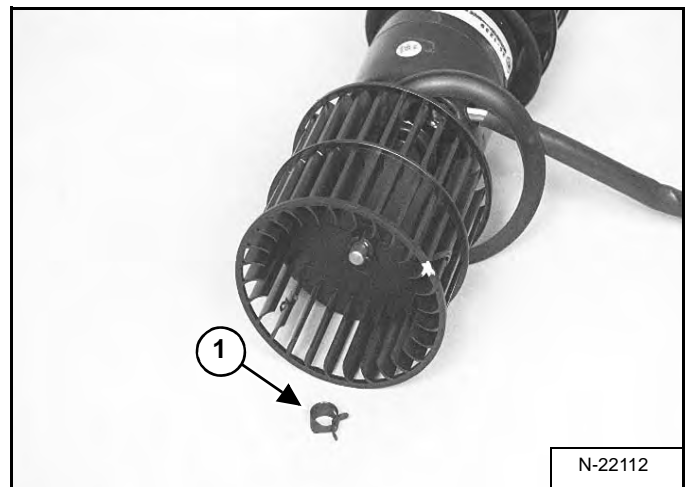

Figure 80-130-12



Remove the outside blower wheel clamp (Item 1) [Figure 80-130-11] & [Figure 80-130-12] from the blower wheel.

TORQUE SPECIFICATIONS FOR BOLTS

Torque For General SAE Bolts

The following table shows standard torque specifications for bolts with zinc phosphate coating. Bolts purchased from Bobcat that have zinc phosphate coating are specified by the letter "H" following the part number.

	THREAD SIZE	SAE GRADE 5	SAE GRADE 8
in.-lb. (N•m)	0.250	80 - 90 (9 - 10)	110 - 120 (13 - 14)
	0.3125	180 - 200 (21 - 23)	215 - 240 (24 - 27)
ft.-lb. (N•m)	0.375	25 - 28 (34 - 38)	35 - 40 (48 - 54)
	0.4375	40 - 45 (54 - 61)	60 - 65 (82 - 88)
	0.500	65 - 70 (88 - 95)	90 - 100 (125 - 135)
	0.5625	90 - 100 (125 - 135)	125 - 140 (170 - 190)
	0.625	125 - 140 (170 - 190)	175 - 190 (240 - 190)
	0.750	220 - 245 (300 - 330)	300 - 330 (410 - 450)
	0.875	330 - 360 (450 - 490)	475 - 525 (645 - 710)
	1.000	475 - 525 (645 - 710)	725 - 800 (985 - 1085)
	1.125	650 - 720 (880 - 975)	1050 - 1175 (1425 - 1600)
	1.250	900 - 1000 (1200 - 1360)	1475 - 1625 (2000 - 2200)
	1.375	1200 - 1350 (1630 - 1830)	2000 - 2200 (2720 - 2980)
	1.500	1500 - 1650 (2040 - 2240)	2600 - 2850 (3530 - 3870)
	1.625	2000 - 2800 (2720 - 2980)	3450 - 3800 (4680 - 5150)
	1.750	2500 - 2750 (3390 - 3730)	4300 - 4800 (5830 - 6500)
	1.875	3150 - 3500 (4270 - 4750)	5500 - 6100 (7450 - 8300)
2.000	3800 - 4200 (5150 - 5700)	6500 - 7200 (8800 - 9800)	

CLICK HERE TO **DOWNLOAD** THE COMPLETE MANUAL

- Thank you very much for reading the preview of the manual.
- You can download the complete manual from: www.heydownloads.com by clicking the link below



- Please note: If there is no response to CLICKING the link, please download this PDF first and then click on it.

CLICK HERE TO **DOWNLOAD** THE COMPLETE MANUAL