



Bobcat®

Service Manual

S185 Skid-Steer Loader

S/N A3L911001 & Above
S/N A3LH11001 & Above
S/N AEYU11001 & Above

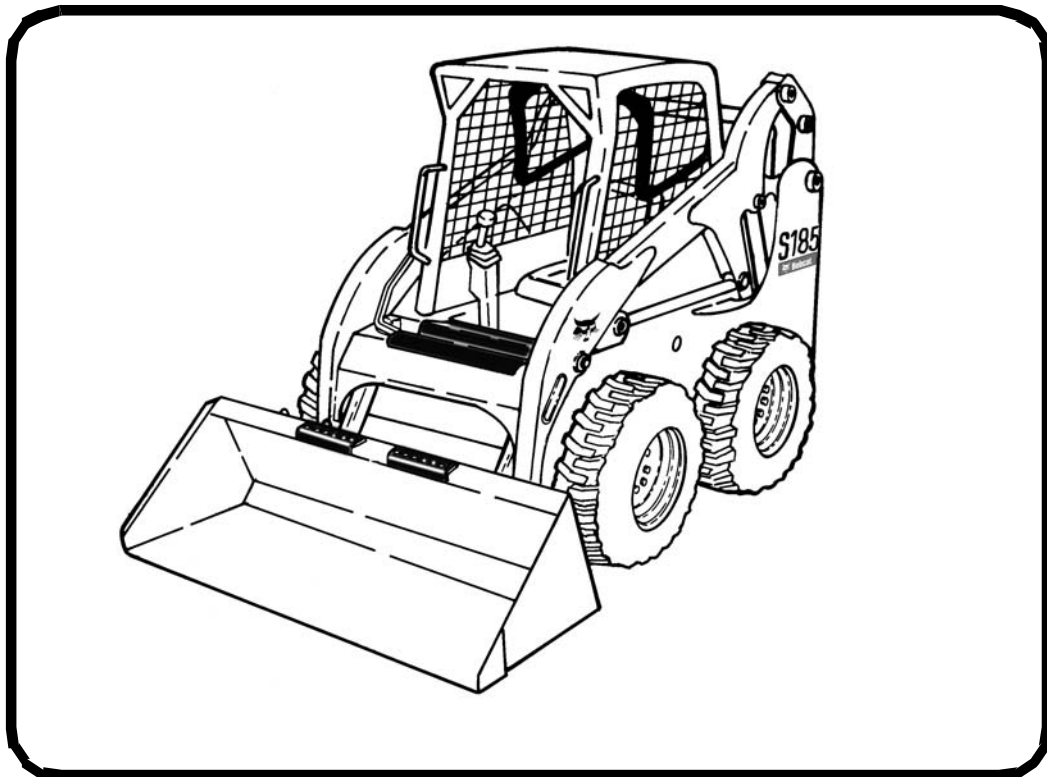

EQUIPPED WITH
BOBCAT INTERLOCK
CONTROL SYSTEM (BICS™)



CLICK HERE TO **DOWNLOAD** THE COMPLETE MANUAL

- Thank you very much for reading the preview of the manual.
- You can download the complete manual from: www.heydownloads.com by clicking the link below



- Please note: If there is no response to CLICKING the link, please download this PDF first and then click on it.

CLICK HERE TO **DOWNLOAD** THE COMPLETE MANUAL



Bobcat®

STOPPING THE ENGINE AND LEAVING THE LOADER	10-200-1
Procedure	10-200-1
EMERGENCY EXIT	10-210-1
Rear Window	10-210-1
Front Door	10-210-1
SEAT BELT	10-220-1
Inspection And Maintenance	10-220-1

TRANSPORTING LOADER ON A TRAILER

Loading And Unloading



AVOID SERIOUS INJURY OR DEATH

Adequately designed ramps of sufficient strength are needed to support the weight of the machine when loading onto a transport vehicle. Wood ramps can break and cause personal injury.

W-2058-0807

Be sure the transport and towing vehicles are of adequate size and capacity for weight of loader. (See Capacities on Page SPEC-10-4.)

Figure 10-40-1

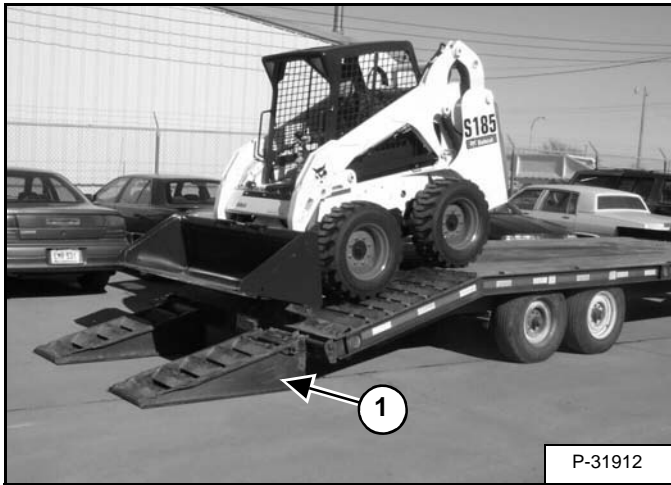

A loader with an empty bucket or no attachment must be loaded backward onto the transport vehicle [Figure 10-40-1].

The rear of the trailer must be blocked or supported (Item 1) [Figure 10-40-1] when loading or unloading the loader to prevent the front end of the trailer from raising up.

Fastening

Figure 10-40-2

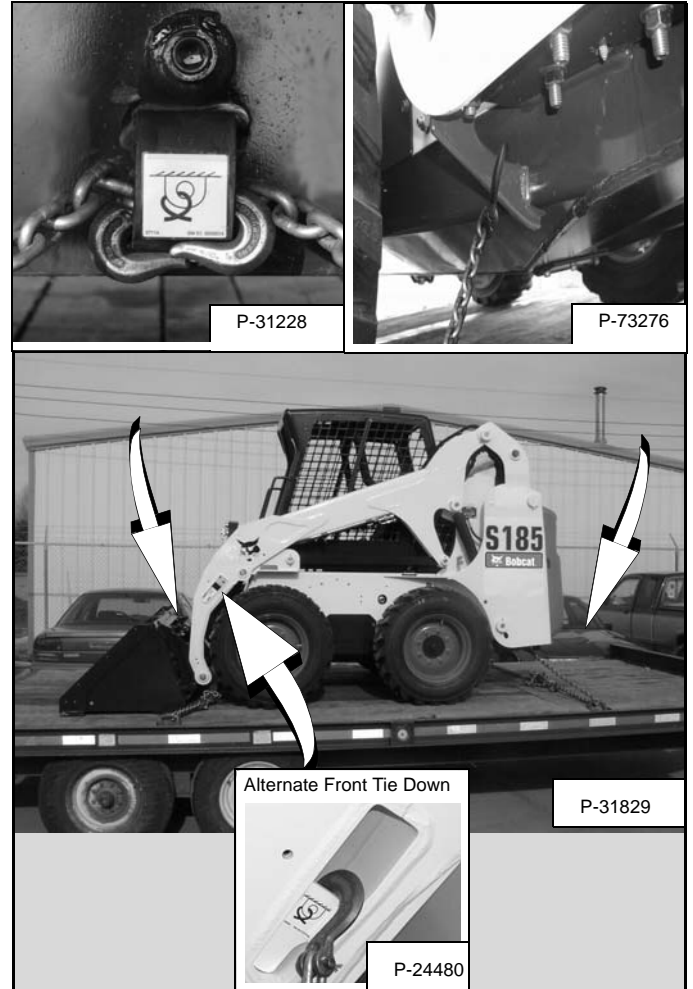

Use the following procedure to fasten the Bobcat loader to the transport vehicle to prevent the loader from moving during sudden stops or when going up or down slopes [Figure 10-40-2].

- Lower the bucket or attachment to the floor.
- Stop the engine.
- Engage the parking brake.
- Install chains at the front and rear loader tie down positions [Figure 10-40-2].
- Fasten each end of the chain to the transport vehicle.
- Use chain binders to tighten the chains.

REMOTE START TOOL (SERVICE TOOL) KIT - 7003031

Description

The Remote Start Tool (Service Tool) Kit is a replacement tool for MEL 1563 Remote Start Tool and MEL 1400B - BOSS® Diagnostic Tool.

The Remote Start Tool (Service Tool) Kit, P/N **7003031**, can be used to service older loaders with the BOSS® system using the supplied BOSS® Service Tool Harness P/N 6689745.

The Remote Start Tool (Service Tool) Kit, P/N **7003031**, can be used to service newer loaders using the supplied harness P/N 6689747.

A computer can be connected to the Remote Start Tool (Service Tool) for diagnostics and software updates using the computer harness P/N 6689746 in conjunction with the loader harness.

AIR CLEANER SERVICE

Replacing Filter Elements

Figure 10-80-1



Figure 10-80-2

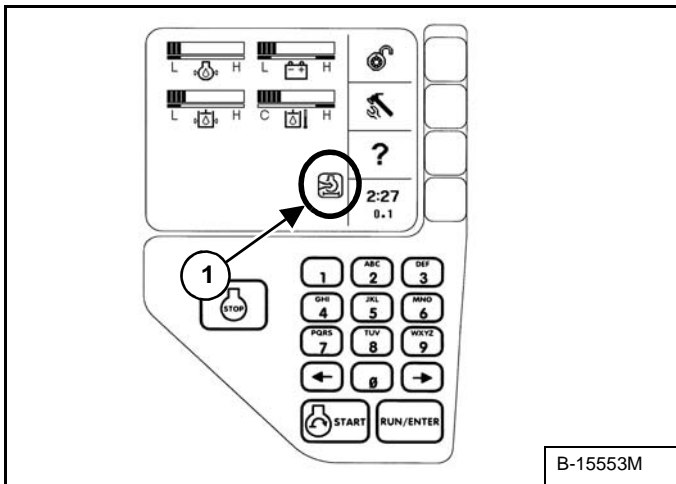

It is important to change the air filter element only when necessary. The Service indicator (Item 1) will FLASH and service code [M0117] (Air Filter Plugged) will show in the Data Display (Item 2) when the Information button (Item 3) [Figure 10-80-1] is held for two seconds.

The Air Cleaner icon on the Deluxe Instrumentation Panel, if equipped, will be ON (Item 1) [Figure 10-80-2].

Replace the inner filter every third time the outer filter is replaced or as indicated.

Outer Filter

Figure 10-80-3

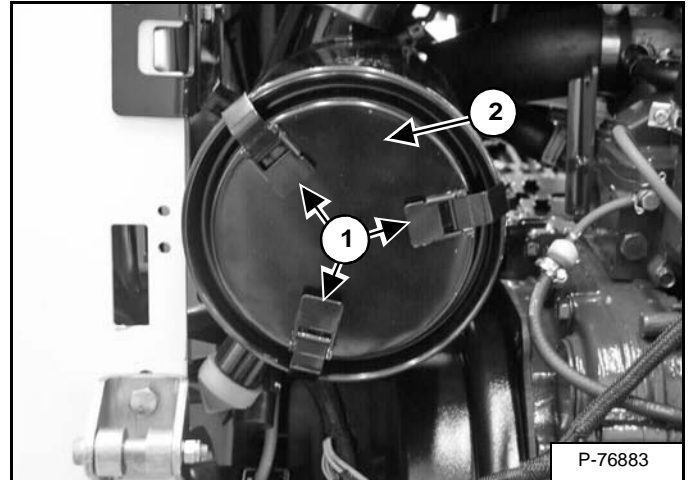

Open the latches (Item 1) and remove the dust cover (Item 2) [Figure 10-80-3].

Figure 10-80-4

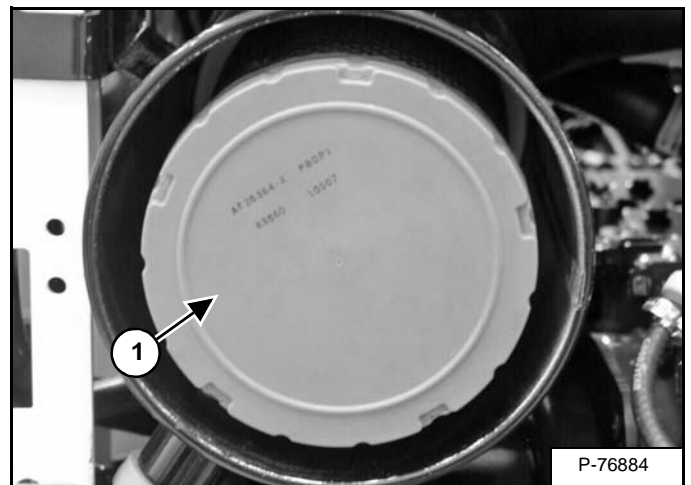

Pull the outer filter element (Item 1) [Figure 10-80-4] out and discard.

NOTE: Make sure all sealing surfaces are free of dirt and debris. Do not use compressed air.

Install new filter element. Push all the way in until it contacts the base of the housing.

Install the dust cover and secure the latches [Figure 10-80-3]

ENGINE LUBRICATION SYSTEM

Checking And Adding Engine Oil

Check the engine oil level every day before starting the engine for the work shift.

Figure 10-110-1

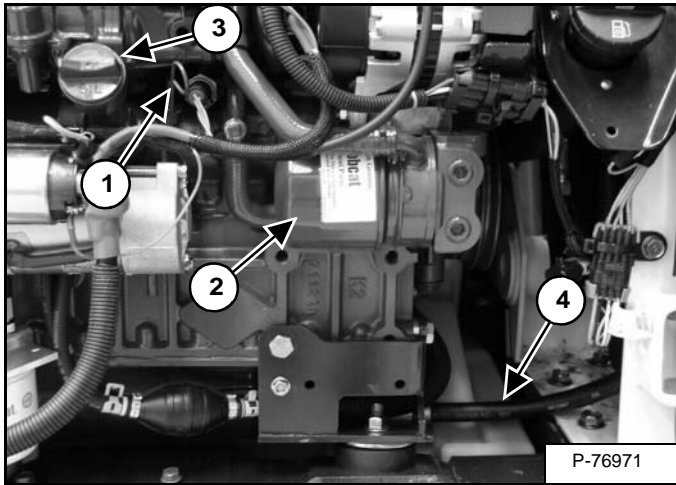

Open the rear door and remove the dipstick (Item 1) [Figure 10-110-1].

Keep the oil level between the marks on the dipstick. Do not overfill.

Engine Oil Chart

ENGINE OIL RECOMMENDED SAE VISCOSITY NUMBER (LUBRICATION OILS FOR DIESEL ENGINE CRANKCASE)

Figure 10-110-2

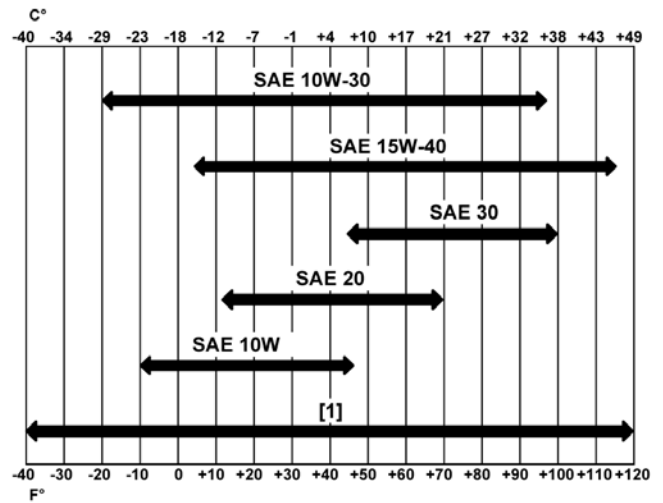

**TEMPERATURE RANGE ANTICIPATED BEFORE
NEXT OIL CHANGE (DIESEL ENGINES MUST USE API
CLASSIFICATION CI-4 OR BETTER)**

[1] Synthetic Oil - Use recommendation from Synthetic Oil Manufacturer.

Use good quality engine oil that meets API Service Classification of CI-4 or better. [Figure 10-110-2].

FINAL DRIVE TRANSMISSION (CHAINCASE)

Checking And Adding Oil

The chaincase contains the final drive sprockets and chains. Use the same type of oil as the hydraulic / hydrostatic system. (See (S185) LOADER SPECIFICATIONS on Page SPEC-10-1.).

Stop the loader on a level surface and stop the engine.

Figure 10-130-1

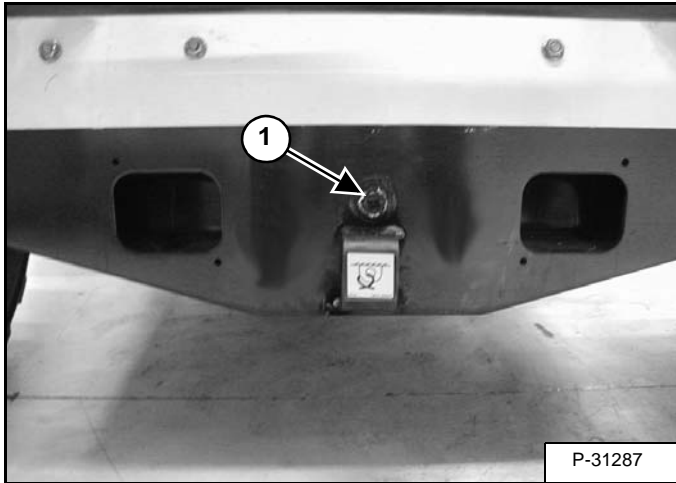

Remove the check plug (Item 1) [Figure 10-130-1] from the front of the chaincase housing.

If oil can be reached with the tip of your finger through the hole, the oil level is correct.

If the level is low, add oil through the check plug hole until oil flows from the hole.

Install and tighten the plug.

Removing And Replacing Oil

Figure 10-130-2

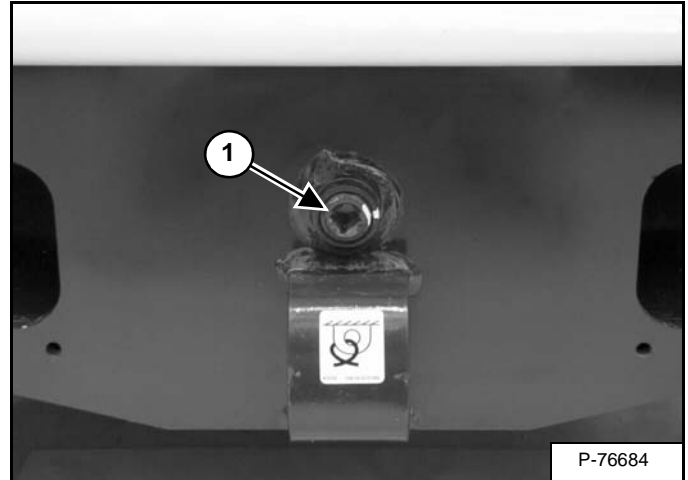

Remove the check plug (Item 1) [Figure 10-130-2] from the front of the chaincase housing.

Figure 10-130-3



Remove the oil from the chaincase [Figure 10-130-3].

Recycle or dispose of the used oil in an environmentally safe manner.

Add oil through the check plug hole until the oil flows from the hole.

! WARNING

AVOID INJURY OR DEATH

Always clean up spilled fuel or oil. Keep heat, flames, sparks or lighted tobacco away from fuel and oil. Failure to use care around combustibles can cause explosion or fire.

W-2103-0508

SPARK ARRESTER MUFFLER

Cleaning Procedure

See the SERVICE SCHEDULE for service interval for cleaning the spark arrester muffler. (See SERVICE SCHEDULE on Page 10-70-1.)

Do not operate the loader with a defective exhaust system.

IMPORTANT

This machine is factory equipped with a U.S.D.A. Forestry Service approved spark arrester exhaust system.

The spark arrester muffler, if equipped, must be cleaned to keep it in working condition. The spark arrester muffler must be serviced by dumping the spark chamber every 100 hours of operation.

On some models, the turbocharger functions as the spark arrester and must operate correctly for proper spark arrester function.

If this machine is operated on flammable forest, brush, or grass covered land, it must be equipped with a spark arrester attached to the exhaust system and maintained in working order. Failure to do so will be in violation of California State Law, Section 4442. PRC. Refer to local laws and regulations for spark arrester requirements.

I-2284-0111

Stop the engine. Open the rear door.

Figure 10-170-1

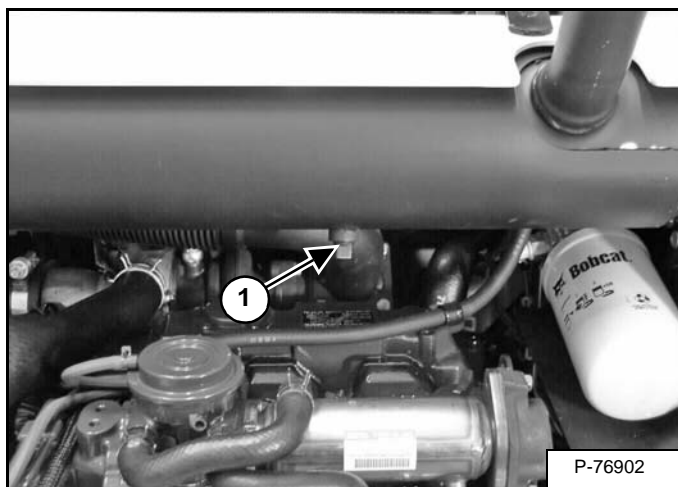

Remove the plug (Item 1) [Figure 10-170-1] from the bottom of the muffler.

! WARNING

When the engine is running during service, the driving and steering controls must be in neutral and the parking brake engaged. Failure to do so can cause injury or death.

W-2006-1209

Start the engine and run for about 10 seconds while a second person, wearing safety glasses, holds a piece of wood over the outlet of the muffler.

This will force contaminants out through the clean out hole.

Stop the engine.

Install and tighten the plug.

Close the rear door.

! WARNING

AVOID INJURY OR DEATH

When an engine is running in an enclosed area, fresh air must be added to avoid concentration of exhaust fumes. If the engine is stationary, vent the exhaust outside. Exhaust fumes contain odorless, invisible gases which can kill without warning.

W-2050-0807

! WARNING

Stop engine and allow the muffler to cool before cleaning the spark chamber. Wear safety goggles. Failure to obey can cause serious injury.

W-2011-1285

! WARNING

Never use machine in atmosphere with explosive dust or gases or where exhaust can contact flammable material. Failure to obey warnings can cause injury or death.

W-2068-1285

SEAT BELT

Inspection And Maintenance

WARNING

Failure to properly inspect and maintain the seat belt can cause lack of operator restraint resulting in serious injury or death.

W-2466-0703

Check the seat belt daily for correct function.

Inspect the seat belt system thoroughly at least once each year or more often if the machine is exposed to severe environmental conditions or applications.

Any seat belt system that shows cuts, fraying, extreme or unusual wear, significant discolorations due to ultraviolet UV exposure, dusty / dirty conditions, abrasion to the seat belt webbing, or damage to the buckle, latch plate, retractor (if equipped), hardware or any other obvious problem should be replaced immediately.

The items below are referenced in **[Figure 10-220-1]**.

1. Check the webbing. If the system is equipped with a retractor, pull the webbing completely out and inspect the full length of the webbing. Look for cuts, wear, fraying, dirt and stiffness.
2. Check the buckle and latch for correct operation. Make sure latch plate is not excessively worn, deformed or buckle is not damaged or casing broken.
3. Check the retractor web storage device (if equipped) by extending webbing to determine if it looks correct and that it spools out and retracts webbing correctly.
4. Check webbing in areas exposed to ultraviolet (UV) rays from the sun or extreme dust or dirt. If the original color of the webbing in these areas is extremely faded and / or the webbing is packed with dirt, the webbing strength may have deteriorated.

See your Bobcat dealer for seat belt system replacement parts for your machine.

Figure 10-220-1

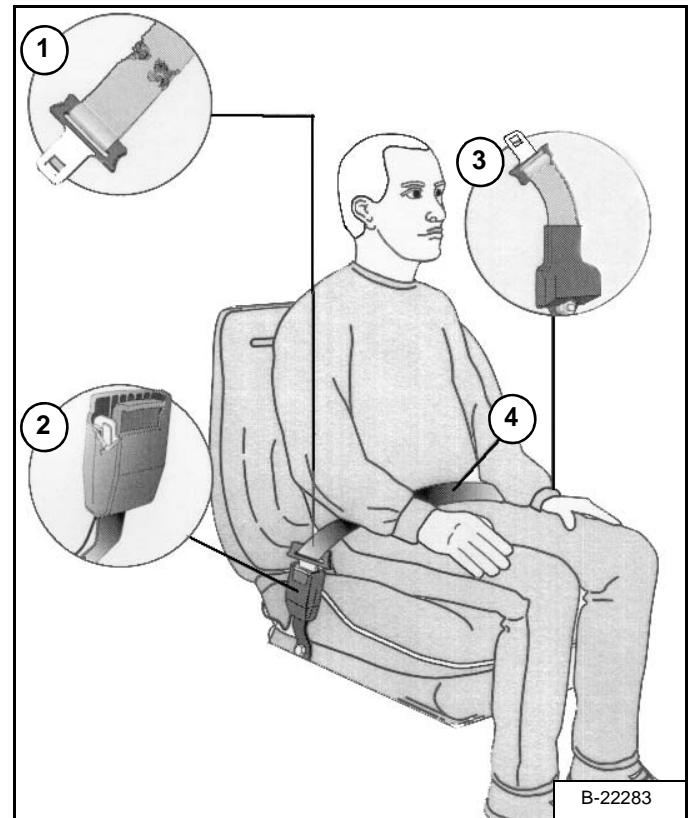

HYDRAULIC/HYDROSTATIC SCHEMATIC WITH 2 SPEED OPTION S185 (S/N A3L911001 AND ABOVE) (S/N A3LH11001 AND ABOVE) (S/N AEYU11001 AND ABOVE)

(PRINTED JANUARY 2009)

V-1131legend LEGEND

- | | | | |
|---|---|--|--|
| <p>① RESERVOIR:
Capacity 19.2 Qts. (18,2 L)</p> <p>② SPRING LOADED FILTER BY-PASS
VALVE: 45-55 PSI (3,1-3,8 Bar)</p> <p>③ DIFFERENTIAL PRESSURE SWITCH:
36-44 PSI (2,5-3,0 Bar)
Normally Closed</p> <p>④ DRIVE MOTOR SHUTTLE VALVE</p> <p>⑤ RELIEF/REPLENISHING VALVE - HIGH
PRESSURE: 5000 PSI (345 Bar)</p> <p>⑥ RELIEF VALVE - CHARGE INLET:
360 PSI (24,8 Bar)
at High Engine Idle
With 140 degrees F. (60 degrees C.) Fluid</p> <p>⑦ FRONT AUXILIARY MANUAL PRESSURE
BLEED-OFF VALVE</p> <p>⑧ HYDRAULIC PUMP Gear Type
16.9 GPM (64 L/min.) at High Engine Idle</p> <p>⑨ RELIEF VALVE - MAIN:
3250-3350 PSI (224-231 Bar)
at Front Quick Couplers</p> <p>⑩ RELIEF/ANTICAVITATION VALVE -
PORT 3500 PSI (241,3 Bar)</p> <p>⑪ ANTICAVITATION VALVE</p> <p>⑫ SOLENOID ACTIVATED DIRECTIONAL
CONTROL VALVE - AUXILIARY</p> <p>⑬ RELIEF/ANTICAVITATION VALVE -
PORT (OPTIONAL) 3500 PSI (241,3 Bar)</p> <p>⑭ LOAD CHECK VALVE</p> | <p>⑮ LIFT CYLINDER SPOOL - MADE TO
RESTRICT FLOW DURING BOOM
DOWN BUT NOT DURING BOOM UP</p> <p>⑯ SOLENOID ACTIVATED DIRECTIONAL
CONTROL VALVE - BICS CONTROL</p> <p>⑰ PILOTED ACTIVATED DIRECTIONAL
CONTROL VALVE - TILT CONTROL</p> <p>⑱ PILOTED ACTIVATED DIRECTIONAL
CONTROL VALVE - LIFT CONTROL</p> <p>⑲ PULL BUTTON ACTIVATED
DIRECTIONAL CONTROL VALVE - LIFT
ARM BY-PASS</p> <p>⑳ PILOTED ACTIVATED DIRECTIONAL
CONTROL VALVE - UNLOADING
SPOOL</p> <p>㉑ PILOTED ACTIVATED DIRECTIONAL
CONTROL VALVE - FLOW CONTROL
SPOOL</p> <p>㉒ FLOW DIVIDER ADJUSTMENT VALVE</p> <p>㉓ SOLENOID ACTIVATED DIRECTIONAL
CONTROL VALVE - BASE</p> <p>㉔ SOLENOID ACTIVATED DIRECTIONAL
CONTROL VALVE - ROD</p> <p>㉕ LOAD SHUTTLE VALVE - BLEED OFF</p> <p>㉖ SOLENOID ACTIVATED DIRECTIONAL
CONTROL VALVE - TWO COIL</p> <p>㉗ PILOT ACTIVATED DIRECTIONAL
CONTROL VALVE - REAR AUXILIARY</p> <p>㉘ RESTRICTOR - 0.140 inch (3,6 mm)</p> <p>㉙ RESTRICTOR - 0.031 inch (0,8 mm)</p> | <p>⑳ RELIEF VALVE: 3300 PSI (228 Bar)</p> <p>㉑ FILTER - HYDRAULIC (CANISTER)</p> <p>㉒ FILTER - CASE DRAIN (SINTERED
BRONZE)</p> <p>㉓ FILTER - BICS CONTROL VALVE
(SCREEN)</p> <p>㉔ CHECK VALVE - BUCKET POSITION
VALVE</p> <p>㉕ RESTRICTION</p> <p>㉖ VARIABLE CAPACITY DISPLACEMENT
BIDIRECTIONAL HYDROSTATIC PUMP</p> <p>㉗ CHECK VALVE - With 5 PSI (0,34 Bar) Spring</p> <p>㉘ BIDIRECTIONAL HYDROSTATIC
MOTOR - 2 SPEED</p> <p>㉙ CHECK VALVE - With 80 PSI (5,5 Bar) Spring</p> <p>㉚ SOLENOID ACTIVATED DIRECTIONAL
CONTROL VALVE - BUCKET POSITION
VALVE (ON/OFF)</p> <p>㉛ CHECK VALVE - BICS CONTROL VALVE</p> <p>㉜ CHARGE PUMP -
12.8 GPM (48,5 L/min) at High Engine Idle</p> <p>㉝ CHECK VALVE - With 300 PSI (20,7 Bar)
Spring And With 0.016 inch (0,40 mm) Orifice</p> <p>㉞ PILOT ACTIVATED DIRECTIONAL
CONTROL VALVE - HYDRAULIC
POWERED BOB-TACH</p> <p>㉟ RESTRICTION - 0.089 inch (2,26 mm)</p> <p>㊱ RESTRICTION - 0.025 inch (0,6 mm)</p> | <p>㊲ RELIEF VALVE - 2000 PSI (137 Bar)</p> <p>㊳ RELIEF VALVE - 1200 PSI (83 Bar)</p> <p>㊴ SOLENOID ACTIVATED DIRECTIONAL
CONTROL VALVE (TWO COIL)</p> <p>㊵ FIXED CAPACITY DISPLACEMENT
HYDRAULIC MOTOR</p> <p>㊶ ANTICAVITATION VALVE</p> <p>㊷ PROPORTIONAL RELIEF VALVE -
(Fan Speed Regulator):
1566 - 1784 PSI (108 - 123 bar)</p> <p>㊸ FILTER - BOB-TACH VALVE</p> <p>㊹ RESTRICTION - 0.343 inch (8,73 mm)</p> <p>㊺ SENSOR - CHARGE PRESSURE - Fan
Filter</p> <p>㊻ SENSOR - HYD. TEMP. - Hyd. Filter</p> <p>㊼ HIGH PRESSURE SHUTTLE</p> <p>㊽ SOLENOID ACTIVATED DIRECTIONAL
CONTROL VALVE - WARM UP</p> <p>㊾ SOLENOID ACTIVATED DIRECTIONAL
CONTROL VALVE - 2 SPEED</p> <p>㊿ PILOT ACTIVATED DIRECTIONAL
CONTROL VALVE - HIGH / LO SPEED</p> <p>① CHECK VALVE - With 125 PSI (8,6 bar) Spring</p> |
|---|---|--|--|

NOTE: Unless otherwise specified
springs have NO significant
pressure value.

HYDRAULIC/HYDROSTATIC SCHEMATIC WITH SJC AND HIGH FLOW OPTION

**S185 (S/N A3L911001 AND ABOVE)
(S/N A3LH11001 AND ABOVE)
(S/N AEYU11001 AND ABOVE)**

(PRINTED JANUARY 2009)

V-1136legend

LEGEND

- | | | | |
|--|---|---|---|
| <p>① RESERVOIR:
Capacity 19.2 qt. (18,2 L)</p> <p>② SPRING LOADED FILTER BY-PASS VALVE: 45-55 PSI (3,1-3,8 bar)</p> <p>③ DIFFERENTIAL PRESSURE SWITCH:
36-44 PSI (2,5-3,0 bar)
Normally Closed</p> <p>④ DRIVE MOTOR SHUTTLE VALVE</p> <p>⑤ RELIEF/REPLENISHING VALVE - HIGH PRESSURE: 5075 PSI (350 bar)</p> <p>⑥ RELIEF VALVE - CHARGE INLET:
360 PSI (24,8 bar)
at High Engine Idle
With 140 degrees F. (60 degrees C.) Fluid</p> <p>⑦ FRONT AUXILIARY MANUAL PRESSURE BLEED-OFF VALVE</p> <p>⑧ HYDRAULIC PUMP Gear Type
16.9 GPM (64 L/min.) at High Engine Idle</p> <p>⑨ RELIEF VALVE - MAIN:
3250-3350 PSI (224-231 bar)
at Front Quick Couplers</p> <p>⑩ PORT RELIEF/ANTICAVITATION VALVE
3500 PSI (241,3 bar)</p> <p>⑪ ANTICAVITATION VALVE</p> <p>⑫ SOLENOID ACTIVATED DIRECTIONAL CONTROL VALVE - AUXILIARY</p> <p>⑬ PORT RELIEF/ANTICAVITATION VALVE:
. (Optional)
3500 PSI (241,3 bar)</p> <p>⑭ LOAD CHECK VALVE</p> <p>⑮ LIFT CYLINDER SPOOL - MADE TO RESTRICT FLOW DURING BOOM DOWN BUT NOT DURING BOOM UP</p> | <p>⑯ SOLENOID ACTIVATED DIRECTIONAL CONTROL VALVE - BICS CONTROL</p> <p>⑰ PILOTED ACTIVATED DIRECTIONAL CONTROL VALVE - TILT CONTROL</p> <p>⑱ PILOTED ACTIVATED DIRECTIONAL CONTROL VALVE - LIFT CONTROL</p> <p>⑲ PULL BUTTON ACTIVATED DIRECTIONAL CONTROL VALVE - LIFT ARM BY-PASS</p> <p>⑳ PILOTED ACTIVATED DIRECTIONAL CONTROL VALVE - UNLOADING SPOOL</p> <p>㉑ PILOTED ACTIVATED DIRECTIONAL CONTROL VALVE - FLOW CONTROL SPOOL</p> <p>㉒ FLOW DIVIDER ADJUSTMENT VALVE</p> <p>㉓ SOLENOID ACTIVATED DIRECTIONAL CONTROL VALVE - BASE</p> <p>㉔ SOLENOID ACTIVATED DIRECTIONAL CONTROL VALVE - ROD</p> <p>㉕ LOAD SHUTTLE VALVE - BLEED OFF</p> <p>㉖ SOLENOID ACTIVATED DIRECTIONAL CONTROL VALVE - TWO COIL</p> <p>㉗ PILOT ACTIVATED DIRECTIONAL CONTROL VALVE - REAR AUXILIARY</p> <p>㉘ RESTRICTOR - 0.140 inch (3,6 mm)</p> <p>㉙ RESTRICTOR - 0.031 inch (0,8 mm)</p> <p>㉚ RELIEF VALVE: 3300 PSI (228 bar)</p> <p>㉛ FILTER - HYDRAULIC (CANISTER)</p> | <p>㉜ FILTER - CASE DRAIN (SINTERED BRONZE)</p> <p>㉝ FILTER - BICS CONTROL VALVE (SCREEN)</p> <p>㉞ CHECK VALVE - BUCKET POSITION VALVE</p> <p>㉟ RESTRICTION</p> <p>㊱ VARIABLE CAPACITY DISPLACEMENT BI-DIRECTIONAL HYDROSTATIC PUMP</p> <p>㊲ SHUTTLE RELIEF VALVE
(Not Adjustable - Factory Set)
65 PSI (4,5 bar)</p> <p>㊳ FIXED CAPACITY DISPLACEMENT BI-DIRECTIONAL HYDROSTATIC MOTOR</p> <p>㊴ CHECK VALVE - With 80 PSI (5,5 bar) Spring</p> <p>㊵ SOLENOID ACTIVATED DIRECTIONAL CONTROL VALVE - BUCKET POSITION VALVE (ON/OFF)</p> <p>㊶ CHECK VALVE - BICS CONTROL VALVE</p> <p>㊷ RESTRICTION - 0.343 inch (8,7 mm)</p> <p>㊸ FILTER - Bob-Tach Valve</p> <p>㊹ PILOT ACTIVATED DIRECTIONAL CONTROL VALVE - HYDRAULIC POWERED BOB-TACH</p> <p>㊺ RESTRICTION - 0.089 inch (2,26 mm)</p> <p>㊻ RESTRICTION - 0.025 inch (0,6 mm)</p> <p>㊼ RELIEF VALVE - 2000 PSI (137 bar)</p> <p>㊽ RELIEF VALVE - 1200 PSI (83 bar)</p> | <p>㊾ SOLENOID ACTIVATED DIRECTIONAL CONTROL VALVE (TWO COIL)</p> <p>㊿ RELIEF VALVE - 3300 PSI (228 bar)</p> <p>① DUMP VALVE - (ON/OFF)</p> <p>② CHECK VALVE</p> <p>③ AUXILIARY HYDRAULIC PUMP - 9.5 GPM (36 L/min) at High Engine Idle</p> <p>④ CHECK VALVE - With 300 PSI (20,7 bar) Spring with 0.016 inch (0,40 mm) orifice</p> <p>⑤ SOLENOID ACTIVATED CONTROL VALVE - FORWARD/REVERSE</p> <p>⑥ SERVO PISTON -Swash Plate</p> <p>⑦ POSITION SENSOR -Swash Plate</p> <p>⑧ CHARGE PRESSURE SENSOR</p> <p>⑨ CHARGE PUMP - 12.8 GPM (48,5 L/min) at High Engine Idle</p> <p>⑩ FIXED CAPACITY DISPLACEMENT HYDRAULIC MOTOR</p> <p>⑪ ANTICAVITATION VALVE</p> <p>⑫ PROPORTIONAL RELIEF VALVE – (Fan Speed Regulator):
1566 - 1784 PSI (108 - 123 bar)</p> <p>⑬ SENSOR – CHARGE PRESSURE – Fan Filter</p> <p>⑭ SENSOR – HYD. TEMP. – Hyd. Filter</p> |
|--|---|---|---|

NOTE: Unless otherwise specified, springs have NO significant pressure value.

CYLINDER (LIFT)

Testing

WARNING

AVOID INJURY OR DEATH

Diesel fuel or hydraulic fluid under pressure can penetrate skin or eyes, causing serious injury or death. Fluid leaks under pressure may not be visible. Use a piece of cardboard or wood to find leaks. Do not use your bare hand. Wear safety goggles. If fluid enters skin or eyes, get immediate medical attention from a physician familiar with this injury.

W-2072-0807

Figure 20-20-1

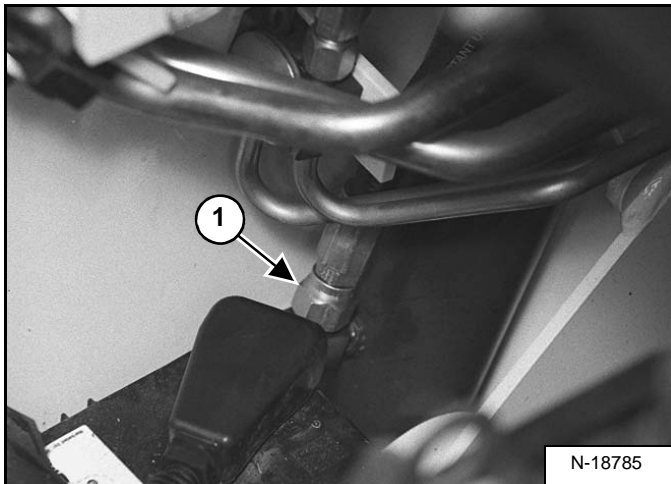

Lower the lift arms. Stop the engine. Pull up on the lift arm bypass control and move the lift pedal to release the hydraulic pressure. Raise the seat bar.

Check only one cylinder at a time. Open the rear door.

Disconnect the negative ground cable to the battery.

Disconnect the hose (Item 1) [Figure 20-20-1] from the lift cylinder base end port.

Figure 20-20-2

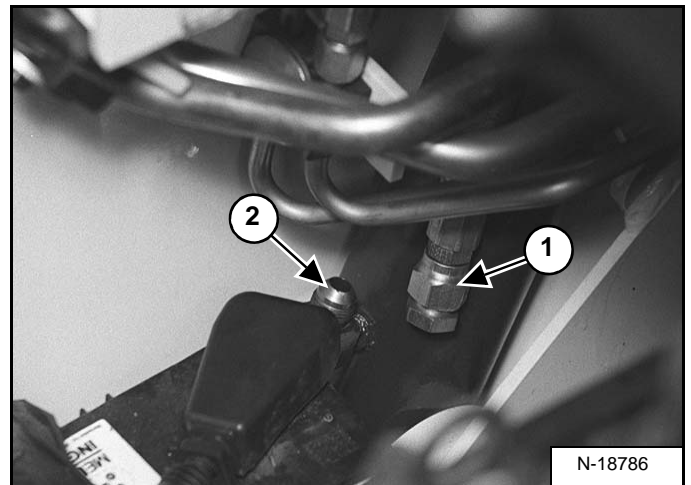

Install a plug in the hose (Item 1) [Figure 20-20-2] and tighten.

Connect the negative ground cable to the battery.

Engage the parking brake. Lower the seat bar. Start the engine. Press the PRESS TO OPERATE BUTTON. Push the top (toe) of the lift pedal.

If there is any leakage from the base end cylinder port (Item 2) [Figure 20-20-2], remove the lift cylinder for repair.

Repeat the procedure to check the other lift cylinder.

WARNING

AVOID INJURY OR DEATH

Always clean up spilled fuel or oil. Keep heat, flames, sparks or lighted tobacco away from fuel and oil. Failure to use care around combustibles can cause explosion or fire.

W-2103-0508

CYLINDER (TILT) (CONT'D)

Removal And Installation (Cont'd)

Figure 20-21-6

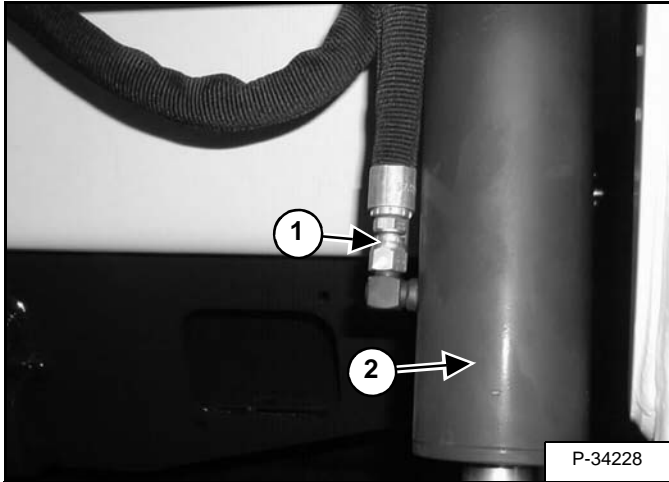

Disconnect the hose (Item 1) [Figure 20-21-6] from the cylinder.

Remove the cylinder (Item 2) [Figure 20-21-6] from the rod end pivot pin.

Remove the cylinder from the loader.

CYLINDER (BOB-TACH) (CONT'D)

Disassembly And Assembly (Cont'd)

Figure 20-22-9

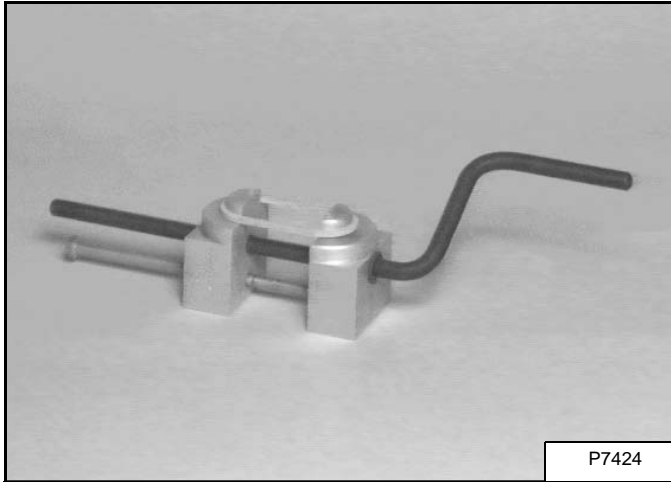

Assembly: Install the new seal on the tool and slowly stretch it until it fits the piston [Figure 20-22-9]. Allow the seal to stretch for 30 seconds before installing it on the piston.

Once the seal is installed on the piston, a piston ring compressor can be used on the piston for 3 minutes to compress the seal into place.

Figure 20-22-10

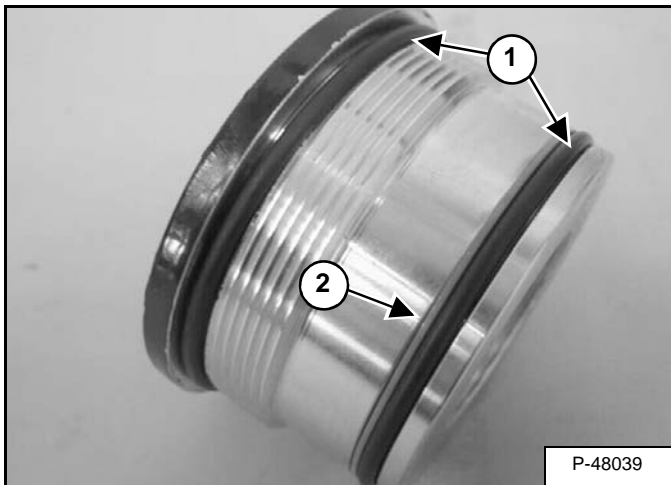

Remove the two O-rings (Item 1) and the back-up washer (Item 2) [Figure 20-22-10] from the cylinder head.

Figure 20-22-11

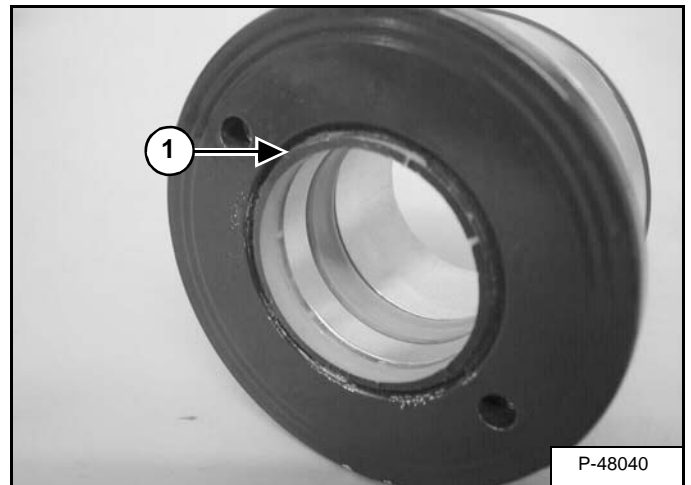

Remove the wiper seal (Item 1) [Figure 20-22-11] from the cylinder head.

Figure 20-22-12

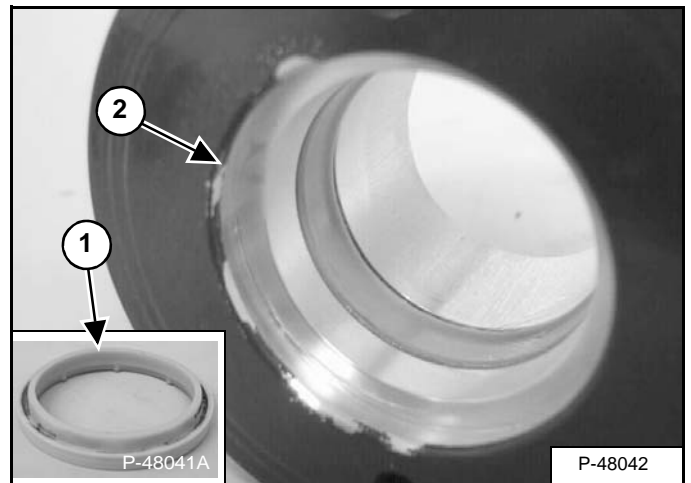

Install the wiper seal, with the wiper side of the seal (Item 1), toward the outside of the head (Item 2) [Figure 20-22-12].

HYDRAULIC CONTROL VALVE (STANDARD) (CONT'D)

Removal And Installation (Cont'd)

Figure 20-40-5

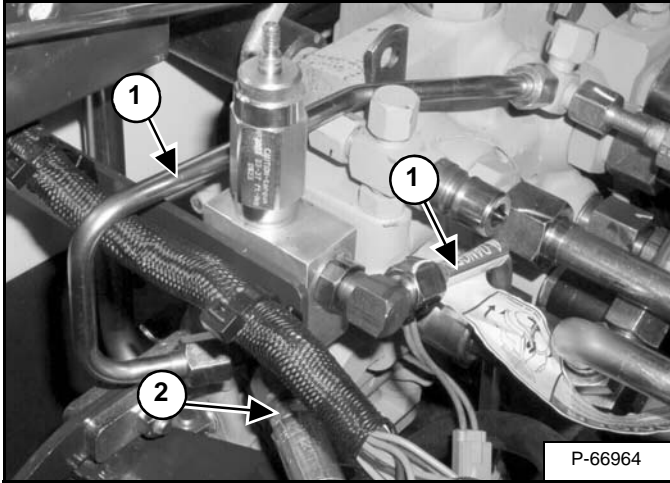

Disconnect and cap the tubelines (Item 1) [Figure 20-40-5] from the lift arm bypass valve to the hydraulic control valve.

Disconnect and cap the hose (Item 2) [Figure 20-40-5] from the lift arm bypass valve to the drive motor case drain.

Figure 20-40-6

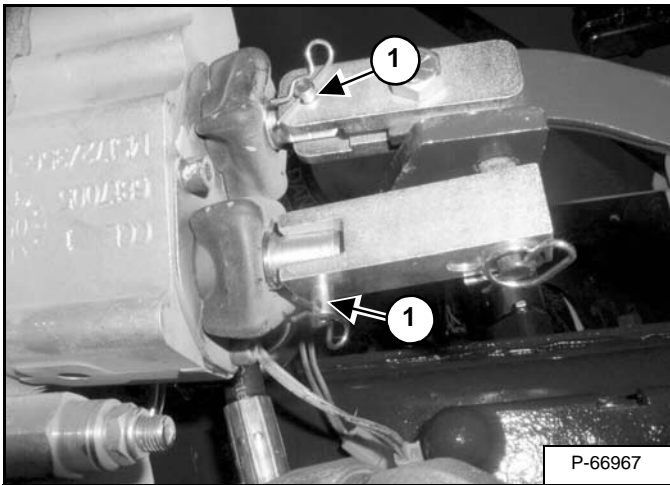

Remove the connector pins (Item 1) [Figure 20-40-6].

Figure 20-40-7

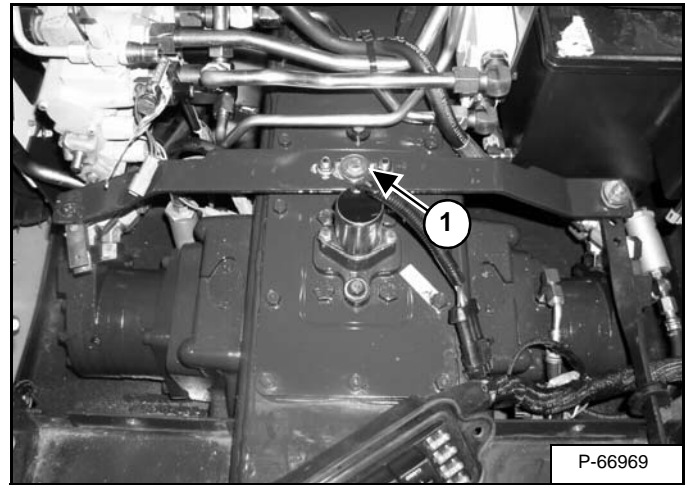

Remove the crossbar linkage bolt (Item 1) [Figure 20-40-7].

Remove the control pedal crossbar linkage and tilt linkage. (See Linkage Removal And Installation on Page 50-90-2.)

Figure 20-40-8

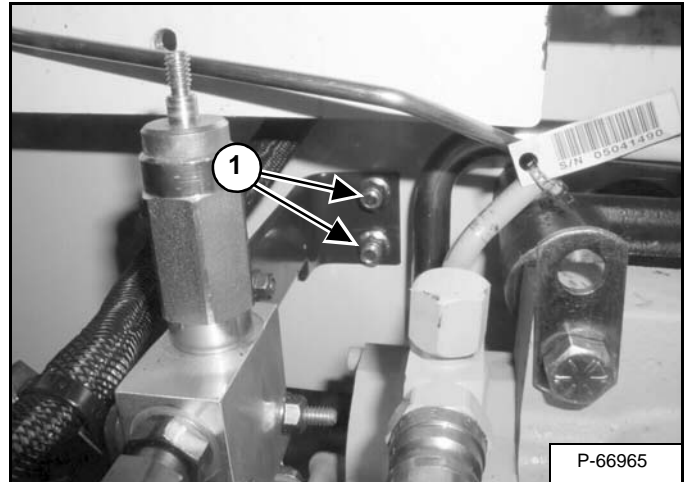

Remove the two lift arm bypass valve bracket mounting bolts (Item 1) [Figure 20-40-8].

Remove the lift arm bypass valve and mounting bracket.

HYDRAULIC CONTROL VALVE (STANDARD) (CONT'D)

Port Relief Valve Removal And Installation (Cont'd)

Figure 20-40-38

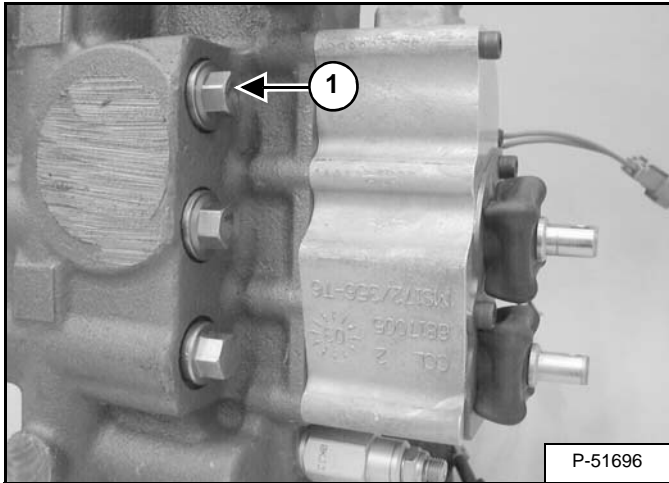

The control valve may be equipped with an optional auxiliary port relief valve (Item 1) [Figure 20-40-38].

Remove the auxiliary port relief valve.

Figure 20-40-39

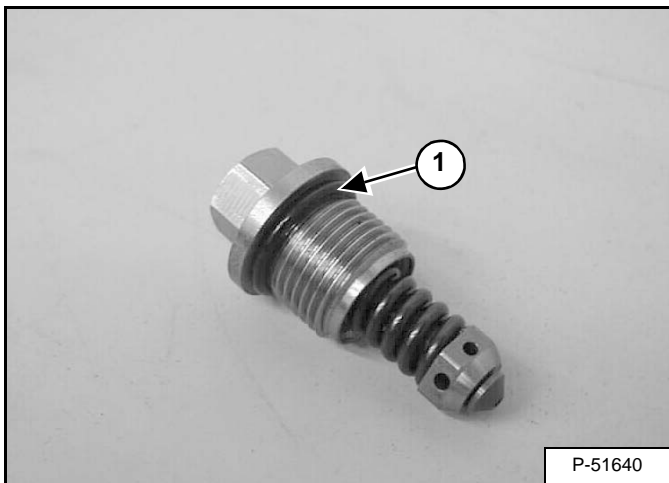

Installation: Always use new O-rings (Item 1) [Figure 20-40-39]. Tighten to 52 - 61 N•m (38 - 45 ft-lb) torque.

Plug Removal And Installation

Figure 20-40-40

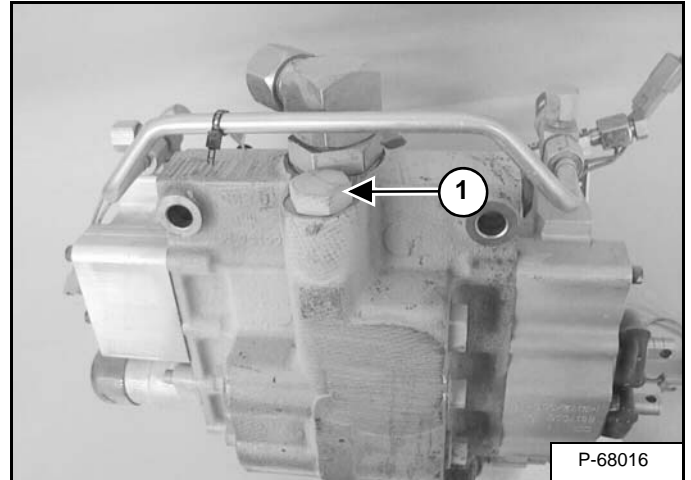

At the top side of the control valve, remove the plug (Item 1) [Figure 20-40-40].

Figure 20-40-41

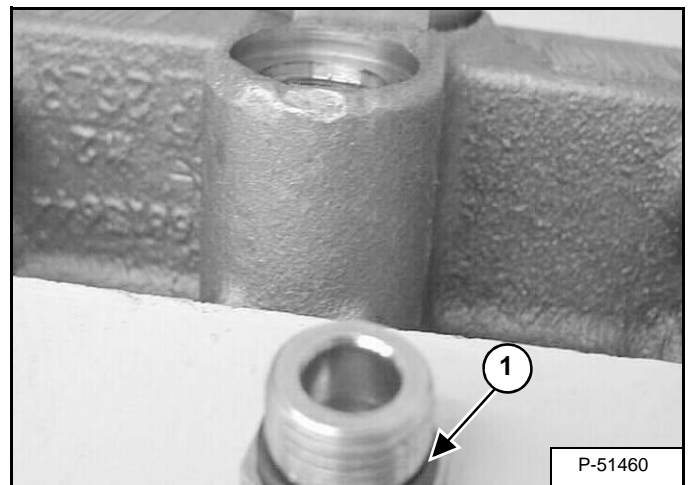

Installation: Always use new O-rings (Item 1) [Figure 20-40-41]. Tighten to 54 N•m (40 ft-lb) torque.

HYDRAULIC CONTROL VALVE (STANDARD) (CONT'D)

Lift Spool And Detent Removal And Installation (Cont'd)

Figure 20-40-77

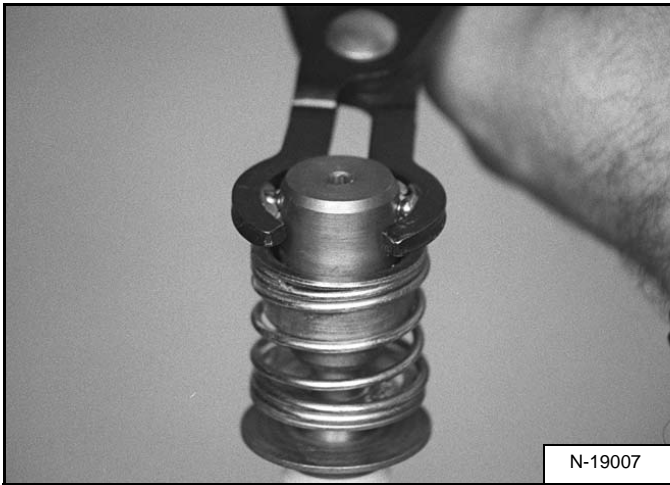

Hold the detent balls in place with the detent pliers [Figure 20-40-77].

Figure 20-40-78

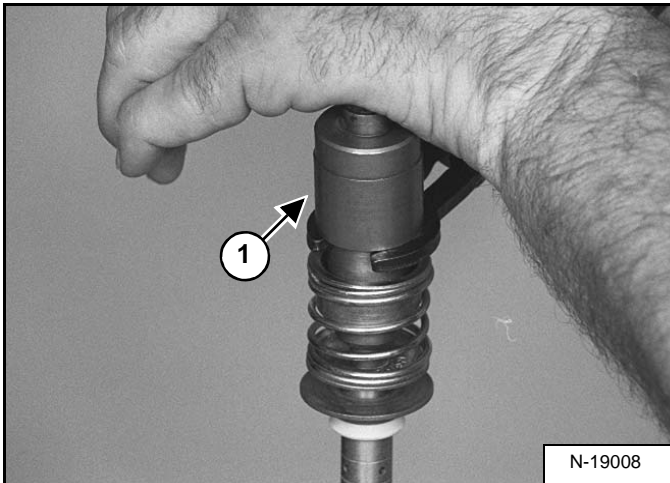

Install the detent sleeve (Item 1) [Figure 20-40-78] to the detent adapter.

Figure 20-40-79

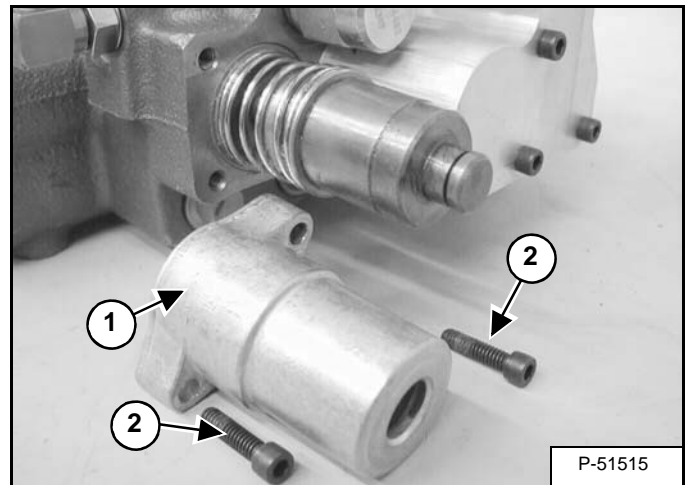

Install the lift spool assembly in the spool bore [Figure 20-40-79].

Install the detent bonnet (Item 1) [Figure 20-40-79].

Install the mounting screws (Item 2) [Figure 20-40-79].

Installation: Lubricate the screws and tighten to 10 - 11,3 N•m (90 - 100 in-lb) torque.

Figure 20-40-80

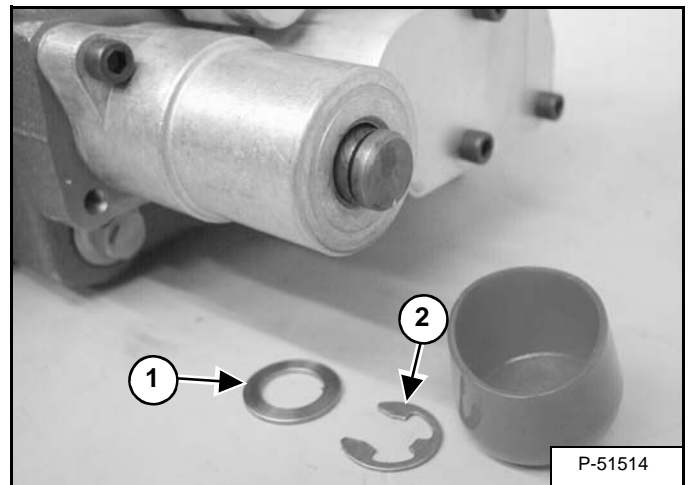

Install the washer (Item 1) and snap ring (Item 2) [Figure 20-40-80].

HYDRAULIC CONTROL VALVE (STANDARD) (CONT'D)

Lock Valve Removal And Installation

Figure 20-40-112

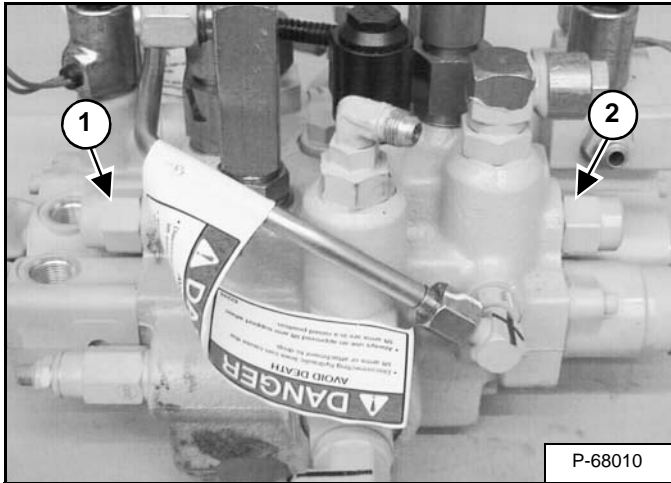

Locate the two BICS™ lock valves, (Item 1) is for the tilt circuit and (Item 2) [Figure 20-40-112] is for the lift circuit.

Figure 20-40-113

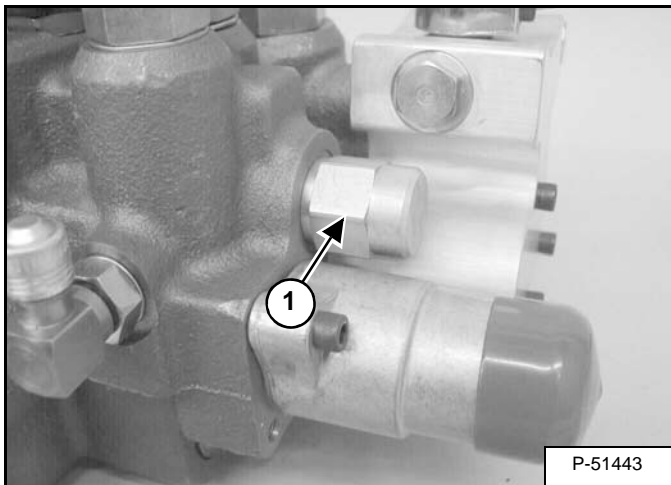

Remove the lift lock valve (Item 1) [Figure 20-40-113] from the back of the control valve.

Installation: Lightly lubricate the lock valve O-rings and tighten to 27 - 33 N•m (20 - 24 ft-lb) torque.

Figure 20-40-114

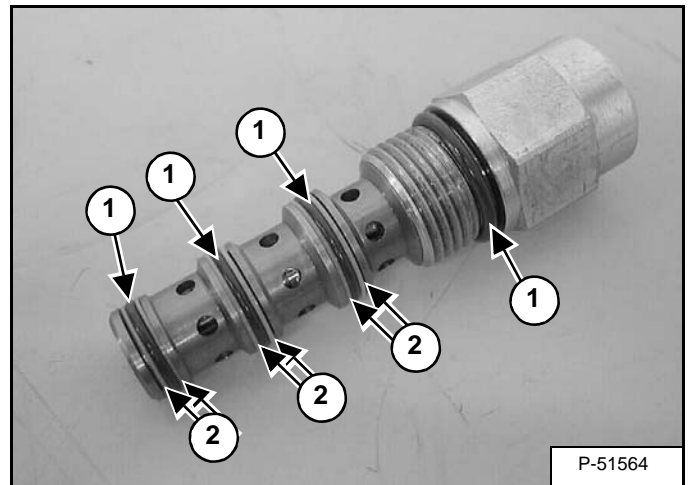

Remove the O-rings (Item 1) and back-up rings (Item 2) [Figure 20-40-114] from the lift lock valve, and replace with new.

HYDRAULIC CONTROL VALVE (ACS) OR (SJC) (CONT'D)

Actuator Removal And Installation (Out of Loader) (Cont'd)

Figure 20-41-20

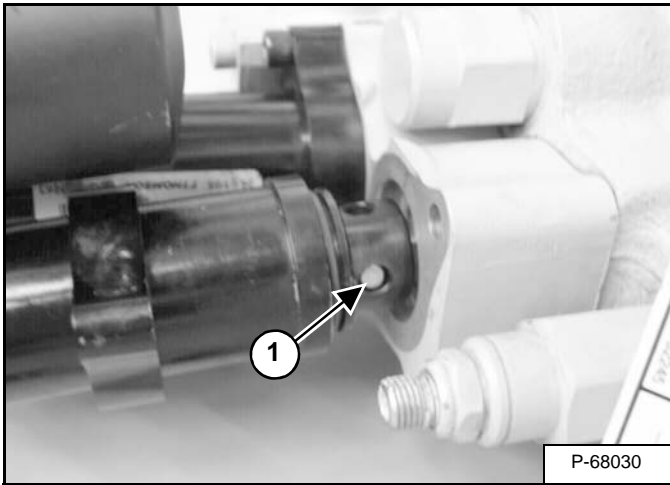

Using a drift pin and a hammer, remove the actuator linkage pin (Item 1) [Figure 20-41-20] from the actuator and the lift spool.

Remove the actuator and linkage pin from the valve.

Figure 20-41-21

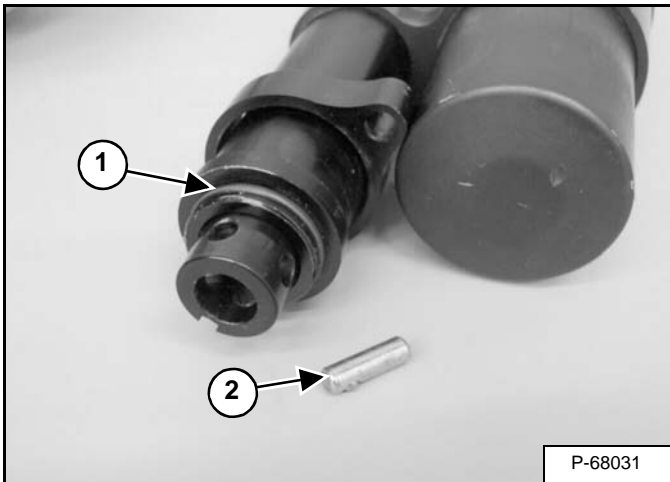

Inspect the O-ring (Item 1) [Figure 20-41-21] on the nose of the actuator, and replace as needed.

Check the linkage pin (Item 2) [Figure 20-41-21] and replace as needed.

Figure 20-41-22

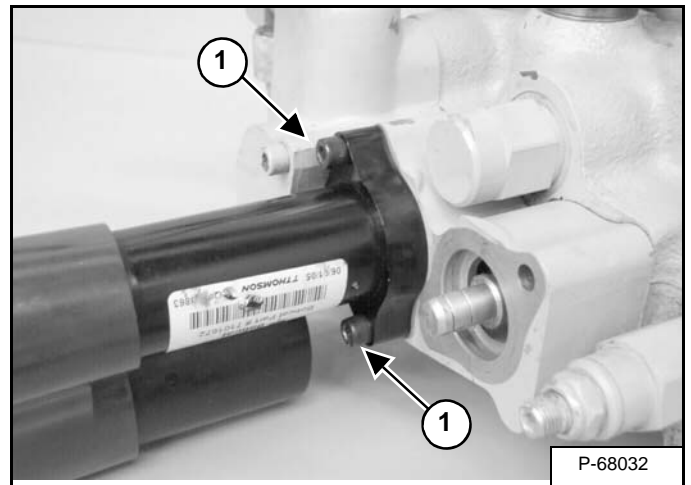

Remove the two mount bolts (Item 1) [Figure 20-41-22] from the tilt actuator.

Installation: Tighten the mounting bolts to 10 - 11,3 N•m (90 - 100 in-lb) torque.

Figure 20-41-23

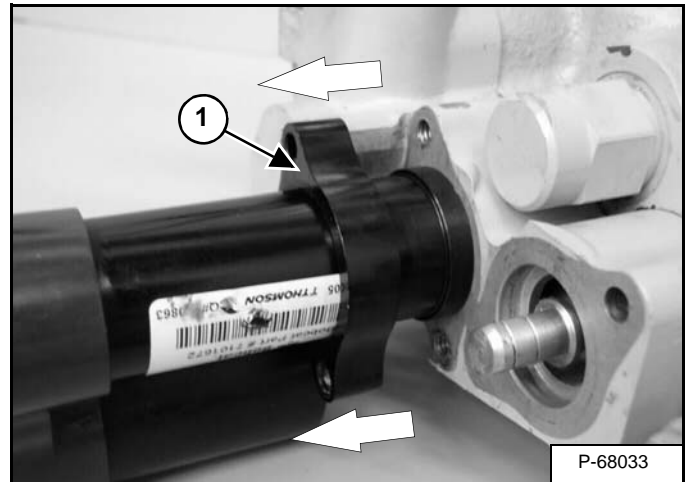

Slide the actuator mount bracket (Item 1) [Figure 20-41-23] away from the control valve.

Pull the actuator away from the control valve [Figure 20-41-23].

HYDRAULIC CONTROL VALVE (ACS) OR (SJC) (CONT'D)

Lift Spool And Detent Removal And Installation

The tool listed will be needed to do the following procedure:

MEL 1285 - Spring Tool

Remove the end cap block from the control valve.

Figure 20-41-54

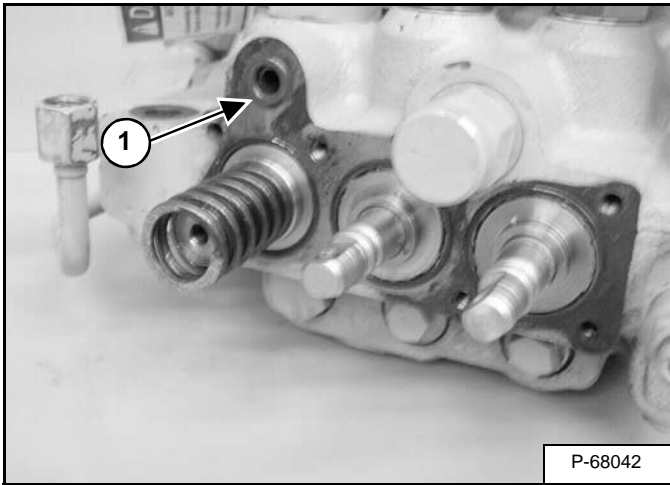

Remove the O-ring (Item 1) [Figure 20-41-54].

Installation: Replace the O-ring, and lubricate lightly with oil before installation of the end cap block.

Figure 20-41-55

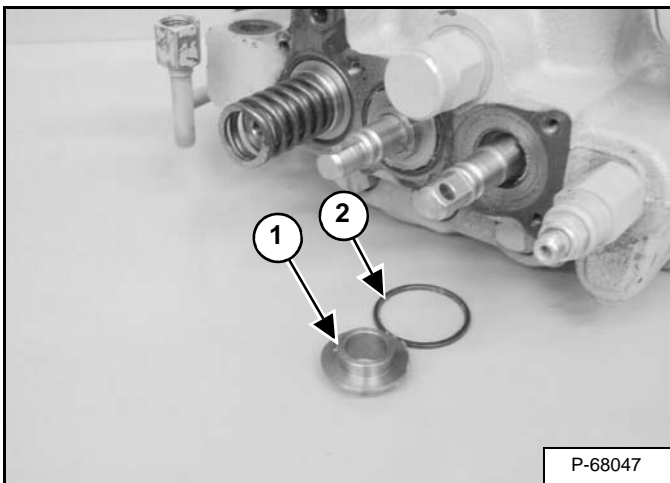

Remove the spacer (Item 1) and O-ring (Item 2) [Figure 20-41-55] from the lift spool.

Figure 20-41-56

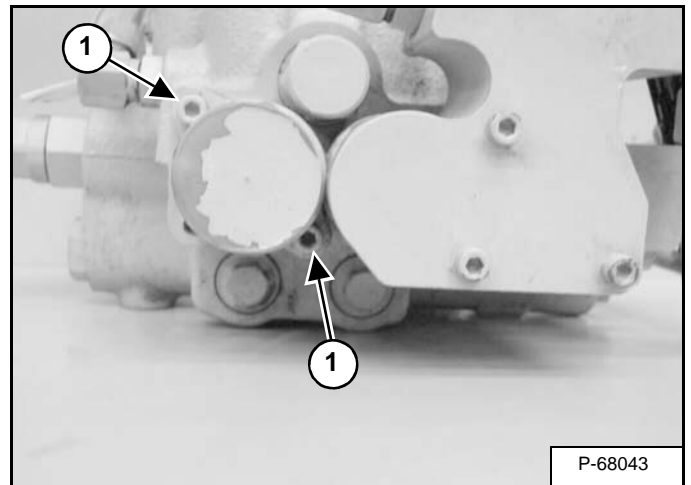

Remove the two screws (Item 1) [Figure 20-41-56] from the lift spool end cap.

Installation: Lubricate the screws and tighten to 10 - 11,3 N•m (90 - 100 in-lb) torque.

Figure 20-41-57

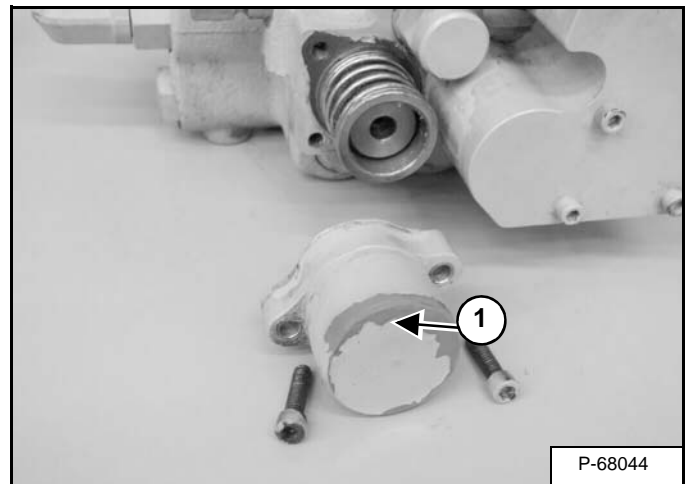

Remove the lift spool end cap (Item 1) [Figure 20-41-57] from the control valve.

**HYDRAULIC CONTROL VALVE (ACS) OR (SJC)
(CONT'D)**

**Auxiliary Solenoid Removal And Installation (S/N
A3L935001 & Above And A3LH35001 & Above)**

Figure 20-41-91

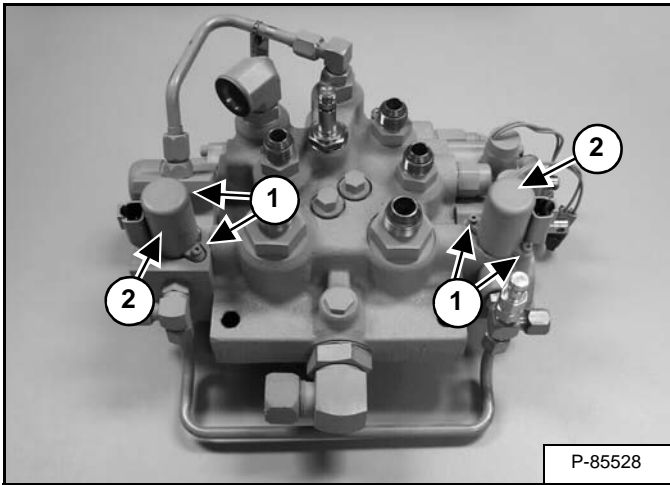

Remove the screws (Item 1) [Figure 20-41-91] from both solenoids.

Remove the solenoids (Item 1) [Figure 20-41-91] from the control valve.

Installation: Tighten the nut to 2,44 - 2,98 N•m (21.6 - 26.4 in-lb) torque.

Figure 20-41-92

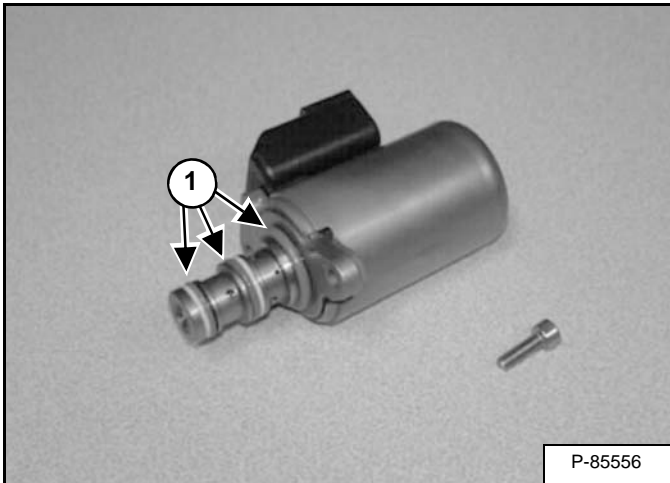

Check and remove the O-rings (Item 1) [Figure 20-41-92] from the solenoid stem.

Use an ohmmeter to measure the solenoid coil resistance.

The correct resistance for the coil is 4.1 ± 6.1 ohm.

HYDRAULIC PUMP (STANDARD) (CONT'D)

Direct Pump Test (Standard Section) (Cont'd)

Figure 20-60-4

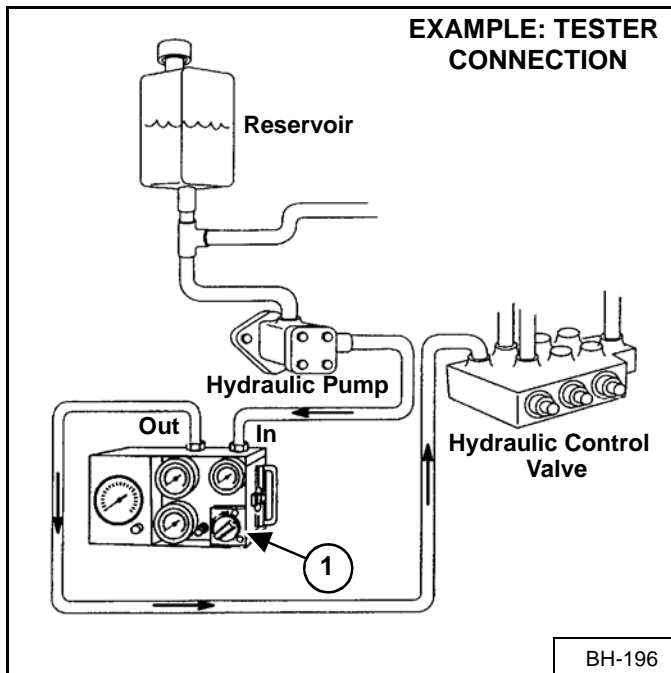

Sample tester connection shown [Figure 20-60-4].

Start the engine and run at low idle rpm. Make sure the tester is connected correctly. If no flow is indicated on the tester, the hoses are connected wrong. With the hoses connected correctly, increase the engine speed to full rpm*.

Warm the fluid to 60°C (140°F) by turning the restrictor control (Item 1) [Figure 20-60-4] on the tester to about 6895 kPa (68,9 bar) (1000 psi). DO NOT exceed system relief pressure. Open the restrictor control and record the free flow (L/min [U.S. gpm]) at full rpm*.

Push the maximum / variable flow switch (on the remote start tool) to engage the front auxiliary hydraulics, the light will come ON. Push the button (on the right control lever) for fluid flow to the quick coupler (fluid pressure will go over main relief). Record the highest pressure (psi) and flow (L/min [U.S. gpm]). The high pressure flow must be at least 80% of free flow.

$$\% = \frac{\text{HIGH PRESSURE FLOW (L/min [U.S. gpm])}}{\text{FREE FLOW (L/min [U.S. gpm])}} \times 100$$

A low percentage may indicate a failed pump.

*Refer to (See Hydraulic System on Page SPEC-10-3.) for system relief pressure and full rpm.

HYDRAULIC PUMP (STANDARD) (CONT'D)

Disassembly And Assembly (Cont'd)

Figure 20-60-27

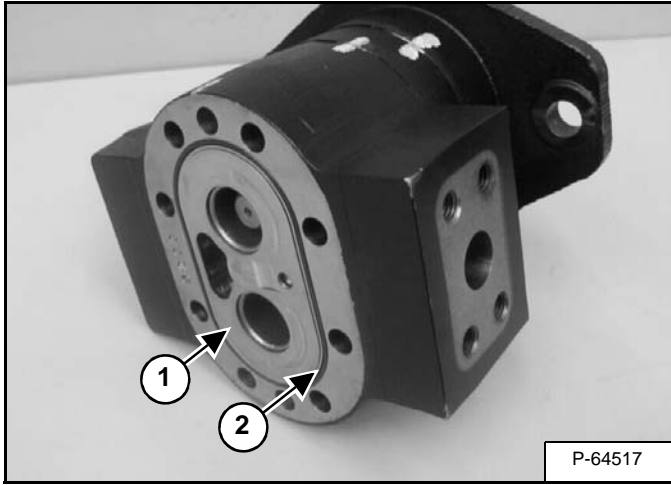
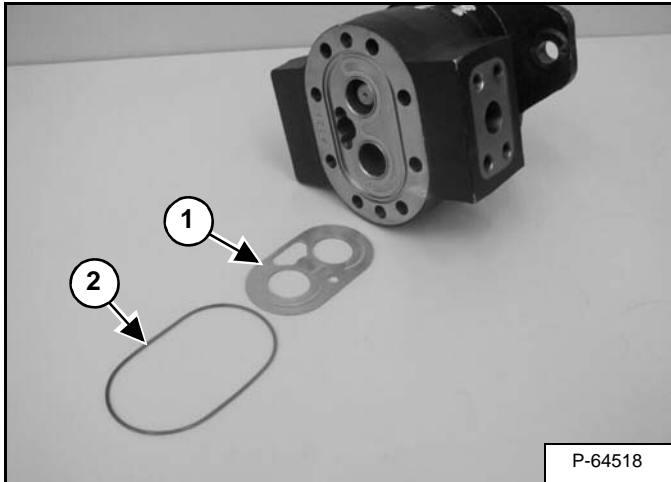

Figure 20-60-28



Remove the wear plate (Item 1) and O-ring (Item 2) [Figure 20-60-27] and [Figure 20-60-28] from the pump center section. Inspect for damage and replace as needed.

NOTE: Position wear plate (Item 1) [Figure 20-60-28] inlets and traps as shown with bronze side toward gears.

Figure 20-60-29

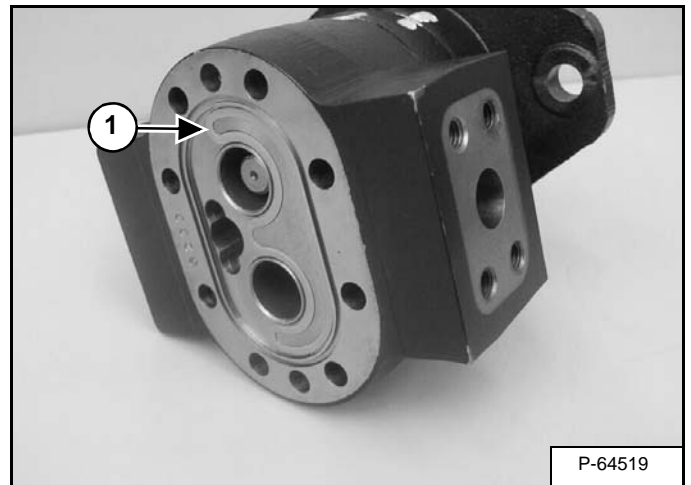
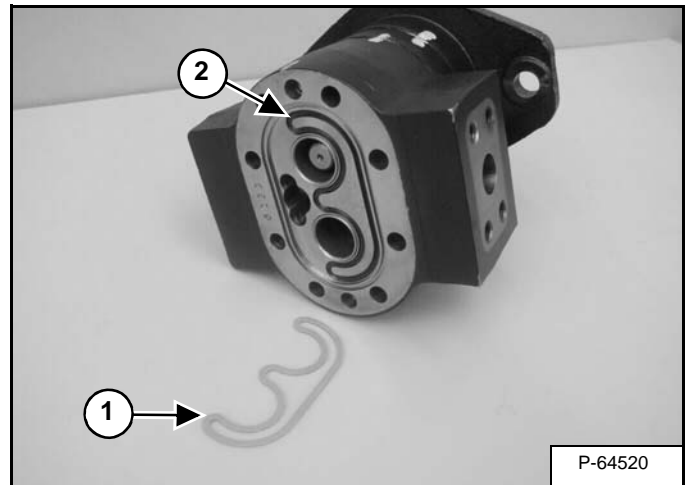

Figure 20-60-30



Remove the load seal (Item 1) [Figure 20-60-29] and [Figure 20-60-30]. Inspect for damage and replace as needed.

Remove the pre-load seal (Item 2) [Figure 20-60-30].

HYDRAULIC PUMP (STANDARD) (HIGH FLOW) (CONT'D)

Direct Pump Test (Charge Section) (Cont'd)

Figure 20-61-7

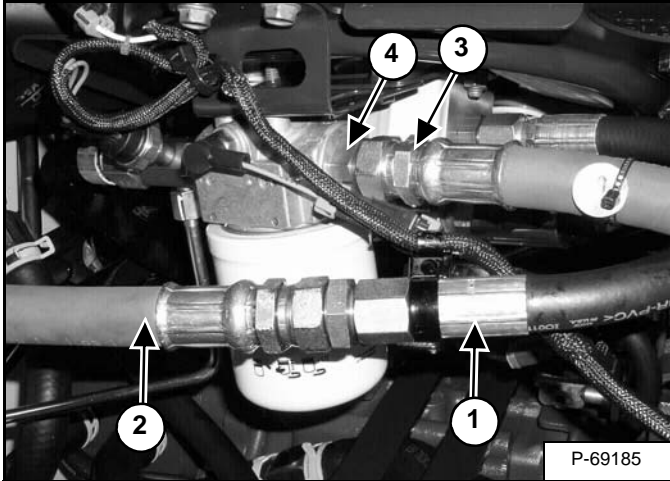

Connect the filter inlet hose (Item 1) to the inlet side of the tester (Item 2) [Figure 20-61-7].

Connect the OUTLET hose (Item 3) from the hydraulic tester to the inlet fitting (Item 4) of the charge filter [Figure 20-61-7].

Figure 20-61-8

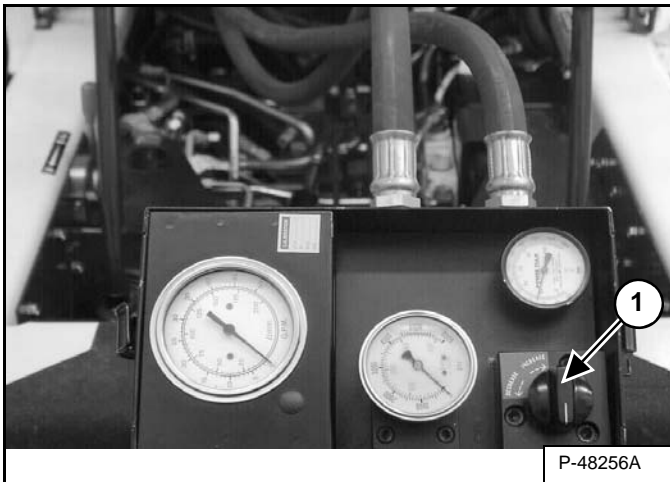

Be sure all connections are tight and that the hoses are not touching any moving parts before starting the loader [Figure 20-61-8].

IMPORTANT

The hydraulic tester must be in the fully open position before you start the engine.

I-2024-0284

Start the engine and run at low idle rpm. Make sure the tester is connected correctly. If no flow is indicated on the tester, the hoses are connected wrong. With the hoses connected correctly, increase the engine speed to full rpm*.

Warm the fluid to 60°C (140°F) by turning the restrictor control (Item 1) [Figure 20-61-8] on the tester to about 4137 kPa (41,4 bar) (600 psi). DO NOT exceed 8274 kPa (82,7 bar) (1200 psi). Open the restrictor control and record the free flow (L/min [U.S. gpm]) at full rpm*.

Turn the restrictor down to system operating pressure approximately 6895 kPa (68,9 bar) (1000 psi). DO NOT EXCEED 8274 kPa (82,7 bar) (1200 psi). Refer to Hydraulic Schematics for flow. The high pressure flow must be at least 80% of free flow.

$$\% = \frac{\text{HIGH PRESSURE FLOW (L/min [U.S. gpm])}}{\text{FREE FLOW (L/min [U.S. gpm])}} \times 100$$

A low percentage may indicate a failed pump.

*Refer to the Hydraulic Schematics for pump flow and rpm.

**HYDRAULIC PUMP (STANDARD) (HIGH FLOW)
(CONT'D)**

Disassembly And Assembly (Cont'd)

Figure 20-61-31

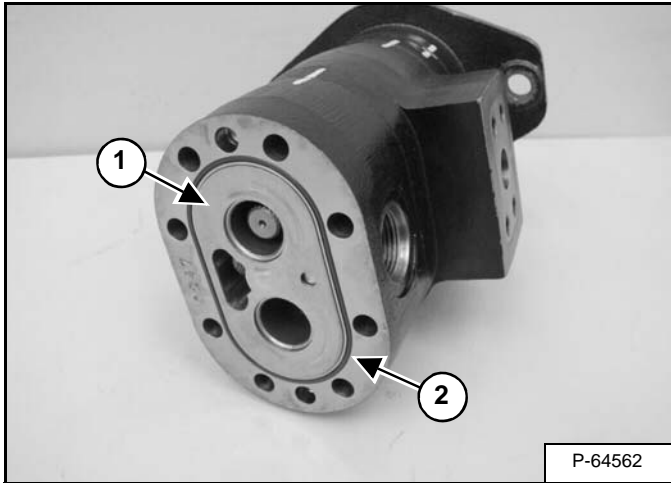
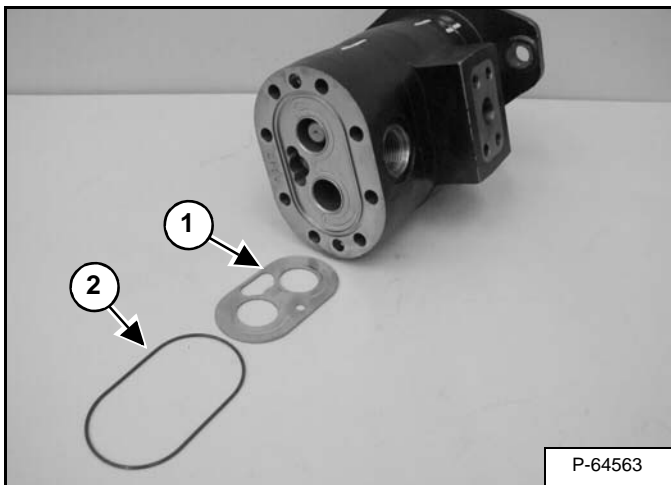

Figure 20-61-32



Remove the wear plate (Item 1) and O-ring (Item 2) [Figure 20-61-31] and [Figure 20-61-32] from the charge center section. Inspect for damage and replace as needed.

NOTE: Position wear plate (Item 1) [Figure 20-61-32] inlets and traps as shown with bronze side toward gears.

Figure 20-61-33

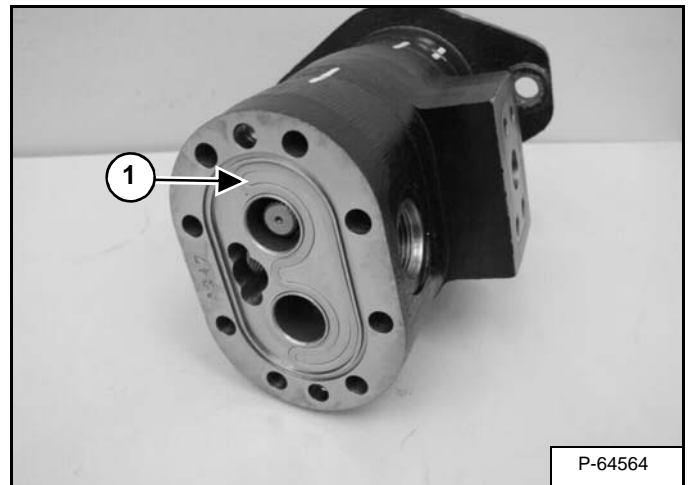
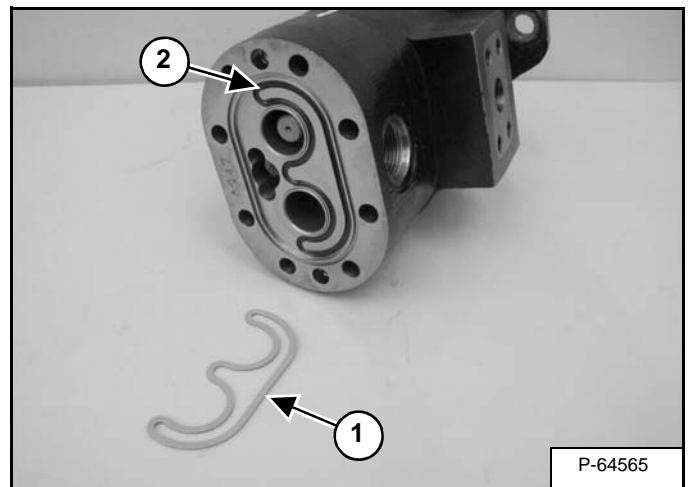

Figure 20-61-34



Remove the load seal (Item 1) [Figure 20-61-33] and [Figure 20-61-34]. Inspect for damage and replace as needed.

Remove the pre-load seal (Item 2) [Figure 20-61-34].

HYDRAULIC PUMP (SJC)

Description

The hydraulic gear pump is attached to the end of the hydrostatic pumps and is located on the right side of the loader between the hydraulic control valve and the engine.

The hydraulic gear pump is a combination of gear pumps that provide hydraulic flow to several hydraulic systems.

The hydraulic gear pump has a dedicated charge pump. This supplies flow to the hydraulic fan motor and charge pressure to the hydrostatic pump.

A seal kit is available to service the hydraulic pump. If any of the main components of the pump are damaged, the entire pump must be replaced.

Pump Test At Quick Couplers

The tools listed will be needed to do the following procedure:

MEL10003 - In-Line Hydraulic Tester
MEL10006 - Flow Meter Fitting Kit

Figure 20-70-1

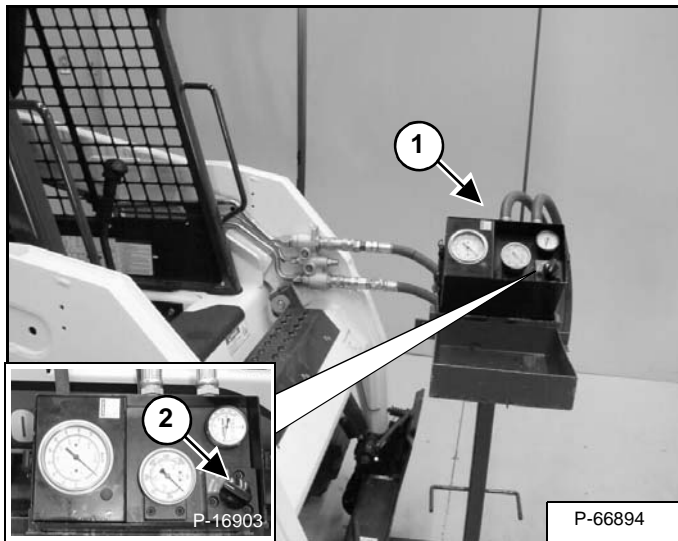

Install a hydraulic tester (Item 1) [Figure 20-70-1] onto the front auxiliary quick couplers.

NOTE: When testing the hydraulic flow of a machine, hoses must be at least 19,05 mm (0.75 in) in diameter and connected directly to the hydraulic tester without using any type of “quick coupler” on the connection to the tester. Also make sure your hydraulic tester is capable of at least 189,3 L/min (50 U.S. gpm).

This procedure will require a operator in the cab and one operator running the tester.

Start the engine and run at low idle rpm. Press the Front Auxiliary button. Engage the front auxiliary with the trigger on the right handle. Make sure the tester is connected correctly. If no flow is indicated on the tester, the hoses are connected wrong. With the hoses connected correctly, increase the engine speed to full rpm*.

Warm the fluid to 60°C (140°F) by turning the restrictor control clockwise on the tester so it reads about a 6895 kPa (68,9 bar) (1000 psi).

NOTE: DO NOT EXCEED 22752,7 kPa (227,5 bar) (3300 psi).

Turn the restrictor control (Item 2) [Figure 20-70-1] on the tester counterclockwise to obtain free flow, the flow should be approximately 60,6 - 34,4 L/min (16 - 17 U.S. gpm). Start turning the restrictor clockwise, causing more restriction on the flow. The L/min (U.S. gpm) should drop off slightly until the pressure reaches approximately 19305 kPa (193,1 bar) (2800 psi). At approximately 19305 kPa (193,1 bar) (2800 psi) the flow should start decreasing rapidly until the pressure reaches 22408 - 22752,7 kPa (224,1 - 227,5 bar) (3250 - 3300 psi). At 22408 - 22752,7 kPa (224,1 - 227,5 bar) (3250 - 3300 psi) the flow should be at 0 L/min (0 U.S. gpm). Turn the restrictor (Item 2) [Figure 20-70-1] counterclockwise to free flow. Shut the front auxiliary hydraulics off.

If flow and pressure specs are not obtained, go to Direct Pump Testing. (See Direct Pump Test (Standard Section) on Page 20-70-2.)

*Refer to (See Hydraulic System on Page SPEC-10-3.) for system relief pressure and full rpm.

HYDRAULIC PUMP (SJC) (CONT'D)

Disassembly And Assembly (Cont'd)

Figure 20-70-19

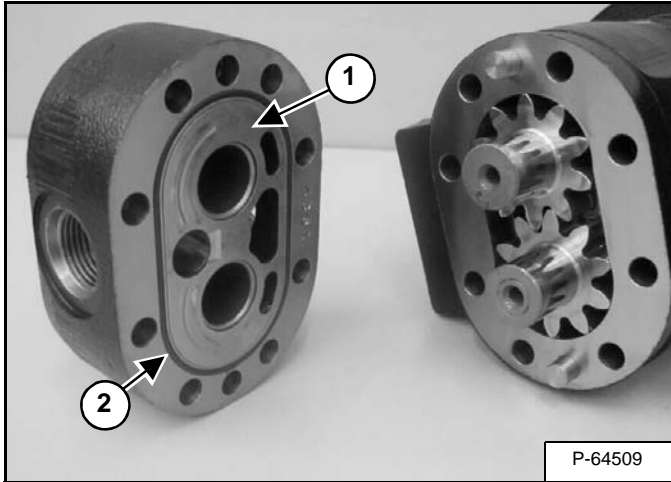
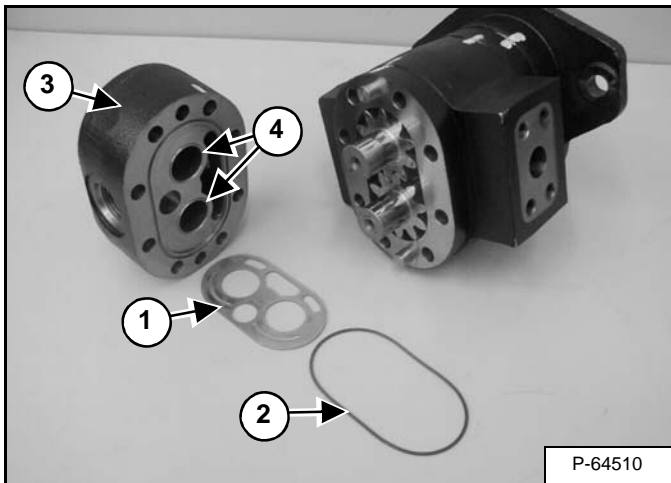

Figure 20-70-20



Remove the wear plate (Item 1) and section seal (Item 2) [Figure 20-70-19] and [Figure 20-70-20] from the pump end section.

NOTE: Position wear plate (Item 1) [Figure 20-70-20] inlets and traps as shown with bronze side toward gears.

NOTE: Inspect the pump end section (Item 3) [Figure 20-70-20] and bushings (Item 4) [Figure 20-70-20]. If excessive wear or damage is visible, the pump must be replaced.

Figure 20-70-21

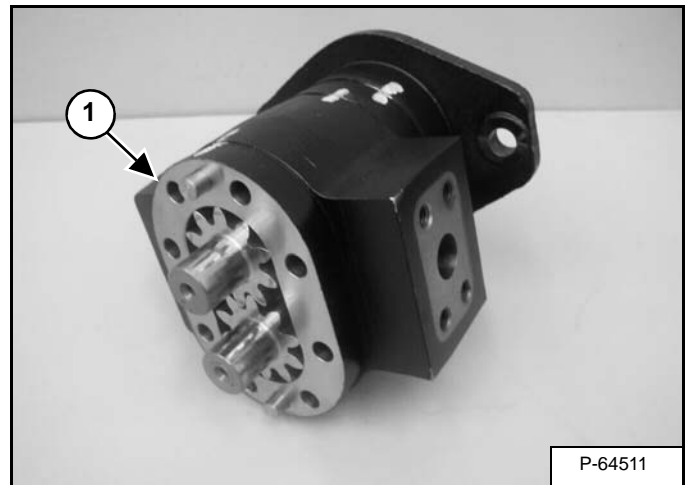
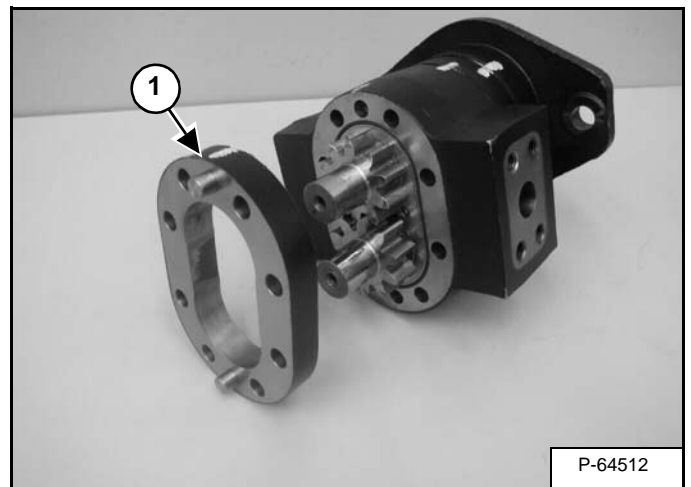

Figure 20-70-22



Remove the charge pump section (Item 1) [Figure 20-70-21] and [Figure 20-70-22] from the pump center section.

NOTE: Inspect the pump section (Item 1) [Figure 20-70-22]. If excessive wear or damage is visible, the pump must be replaced.

HYDRAULIC PUMP (SJC) (HIGH FLOW) (CONT'D)

Direct Pump Test (Standard Section) (Cont'd)

Figure 20-71-4

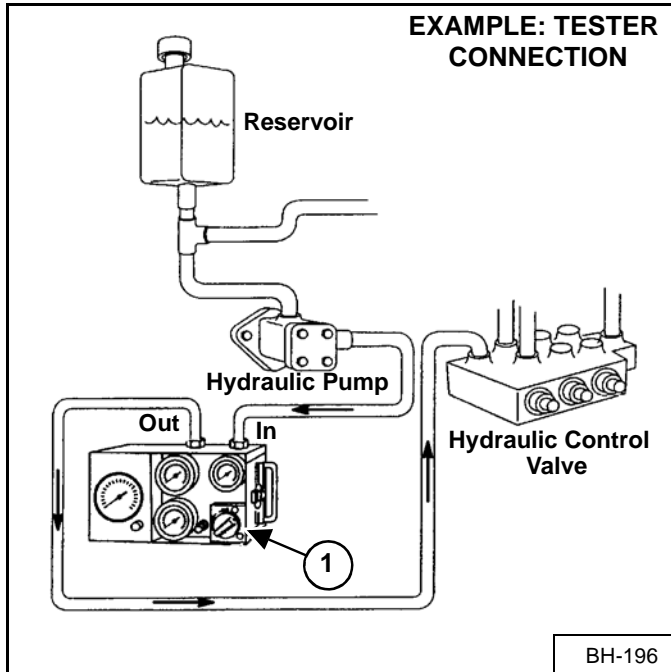

Sample tester connection shown [Figure 20-71-4].

Start the engine and run at low idle rpm. Make sure the tester is connected correctly. If no flow is indicated on the tester, the hoses are connected wrong. With the hoses connected correctly, increase the engine speed to full rpm*.

Warm the fluid to 60°C (140°F) by turning the restrictor control (Item 1) [Figure 20-71-4] on the tester to about 6895 kPa (68,9 bar) (1000 psi). DO NOT exceed system relief pressure. Open the restrictor control and record the free flow (L/min [U.S. gpm]) at full rpm*.

Push the maximum / variable flow switch (on the remote start tool) to engage the front auxiliary hydraulics, the light will come ON. Push the button (on the right control lever) for fluid flow to the quick coupler (fluid pressure will go over main relief). Record the highest pressure (psi) and flow (L/min [U.S. gpm]). The high pressure flow must be at least 80% of free flow.

$$\% = \frac{\text{HIGH PRESSURE FLOW (L/min [U.S. gpm])}}{\text{FREE FLOW (L/min [U.S. gpm])}} \times 100$$

A low percentage may indicate a failed pump.

*Refer to (See Hydraulic System on Page SPEC-10-3.) for system relief pressure and full rpm.

HYDRAULIC PUMP (SJC) (HIGH FLOW) (CONT'D)

Disassembly And Assembly (Cont'd)

Figure 20-71-24

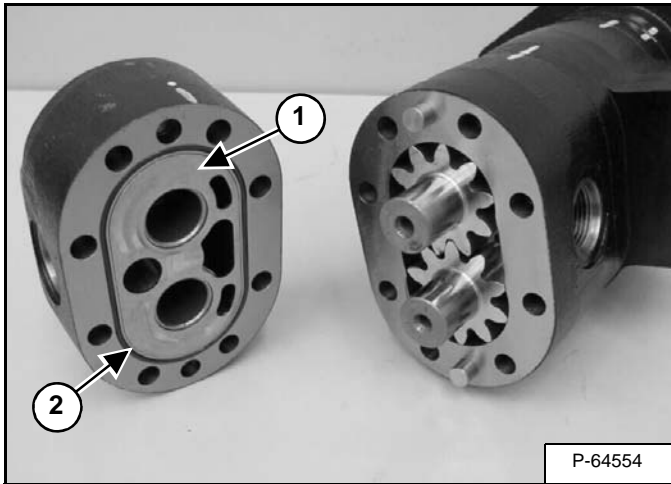
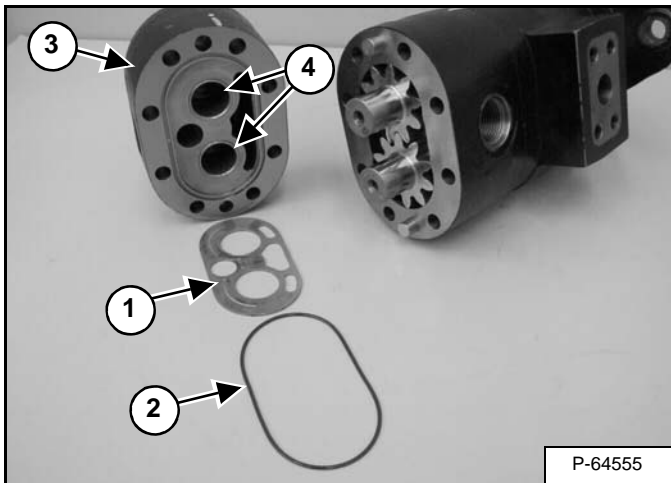

Figure 20-71-25



Remove the wear plate (Item 1) and O-ring (Item 2) [Figure 20-71-24] and [Figure 20-71-25] from the high flow end section.

NOTE: Position wear plate (Item 1) [Figure 20-71-25] inlets and traps as shown with bronze side toward gears.

NOTE: Inspect the high flow end section (Item 3) and bushings (Item 4) [Figure 20-71-25]. If excessive wear or damage is visible, the pump must be replaced.

Figure 20-71-26

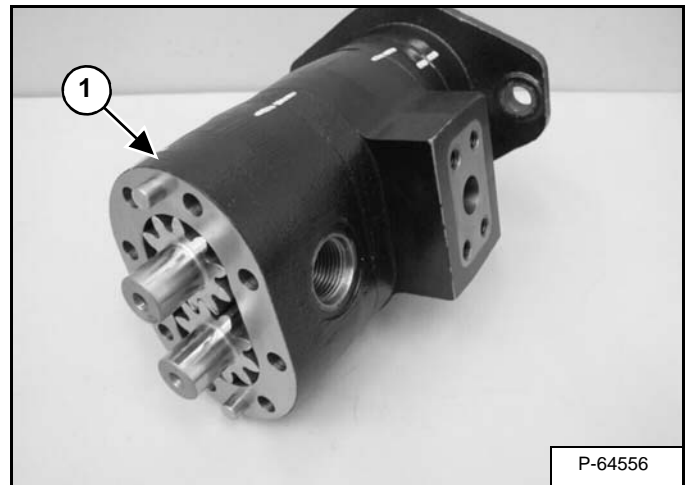
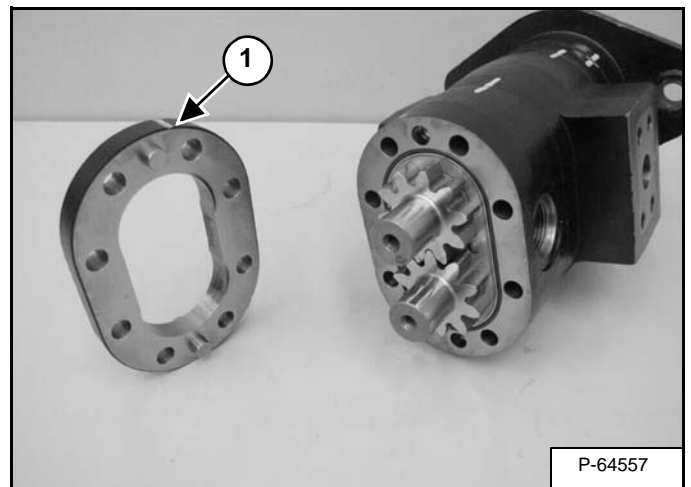

Figure 20-71-27



Remove the high flow pump section (Item 1) [Figure 20-71-26] and [Figure 20-71-27] from the charge center section.

NOTE: Inspect the high flow pump section (Item 1) [Figure 20-71-27]. If excessive wear or damage is visible, the pump must be replaced.

HYDRAULIC PUMP (SJC) (HIGH FLOW) (CONT'D)

Disassembly And Assembly (Cont'd)

Figure 20-71-64

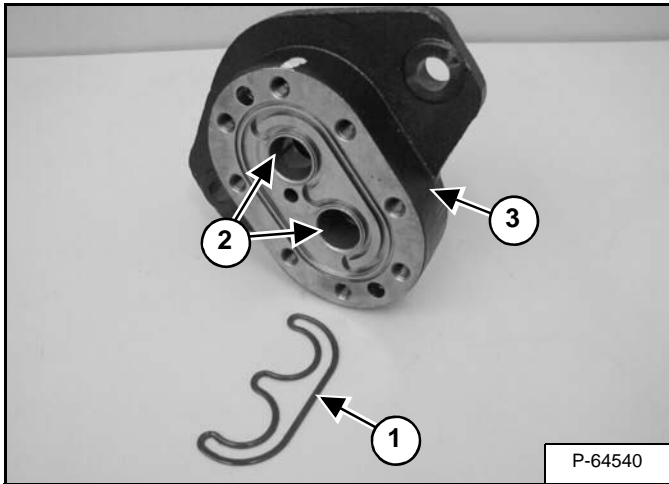

Inspect the pre-load seal (Item 1) [Figure 20-71-64] for damage and replace as needed.

NOTE: Inspect the pump flange section (Item 2) and bushings (Item 3) [Figure 20-71-64]. If excessive wear or damage is visible, the pump must be replaced.

Figure 20-71-65

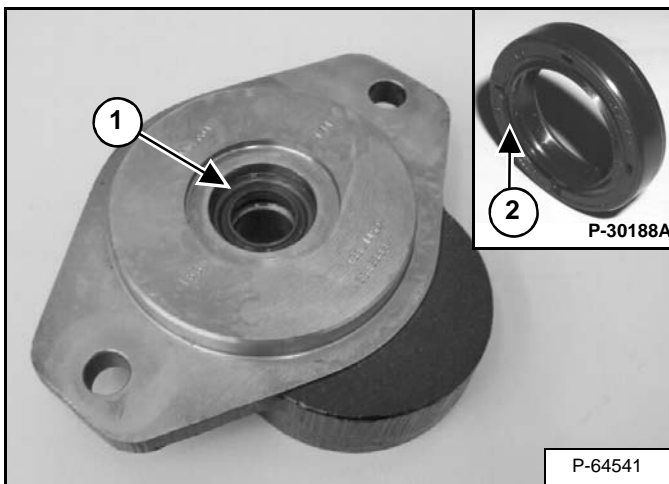

Remove the shaft seal (Item 1) [Figure 20-71-65] from the pump flange section.

Installation: The shaft seal flush surface (Item 2) [Figure 20-71-65] must be facing out away from the pump.

OIL COOLER

Description

The oil cooler is used to cool the loaders hydraulic and hydrostatic oil. Oil passages are coiled into a heat exchanger. Air is forced, with the cooling fan, around the passages cooling the oil.

The oil cooler is located underneath the rear grille between the A/C condenser (if so equipped) and the radiator.

Removal And Installation

IMPORTANT

When repairing hydrostatic and hydraulic systems, clean the work area before disassembly and keep all parts clean. Always use caps and plugs on hoses, tubelines and ports to keep dirt out. Dirt can quickly damage the system.

I-2003-0888

Remove the rear grille from the loader. (See Removal And Installation on Page 50-60-1.)

Figure 20-100-1

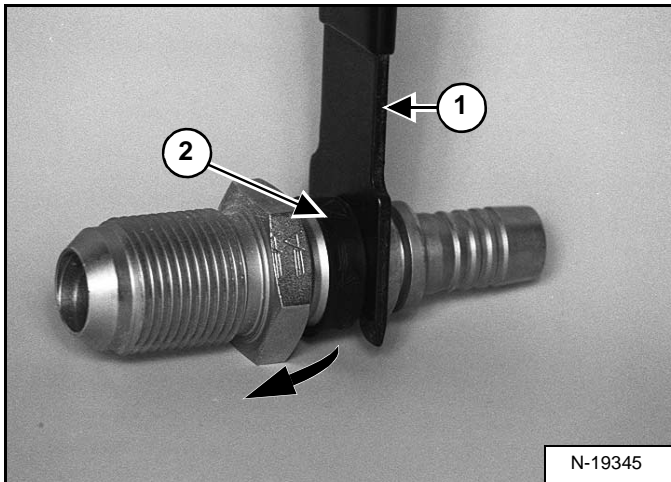

Install tool MEL 1558 (Item 1) to outside of rubber sleeve (Item 2) [Figure 20-100-1].

Figure 20-100-2

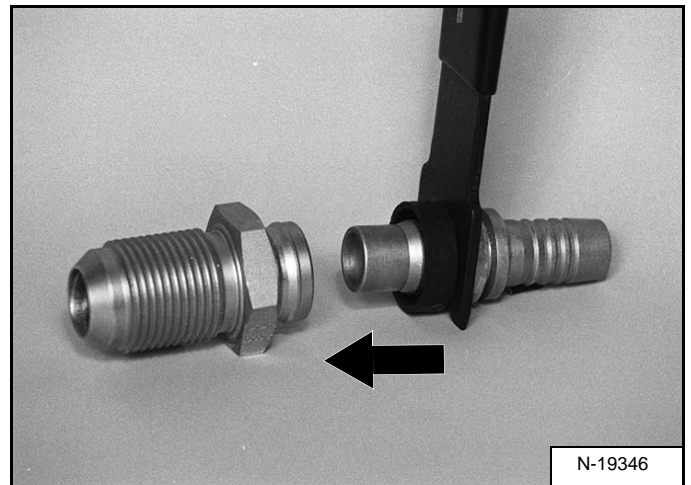
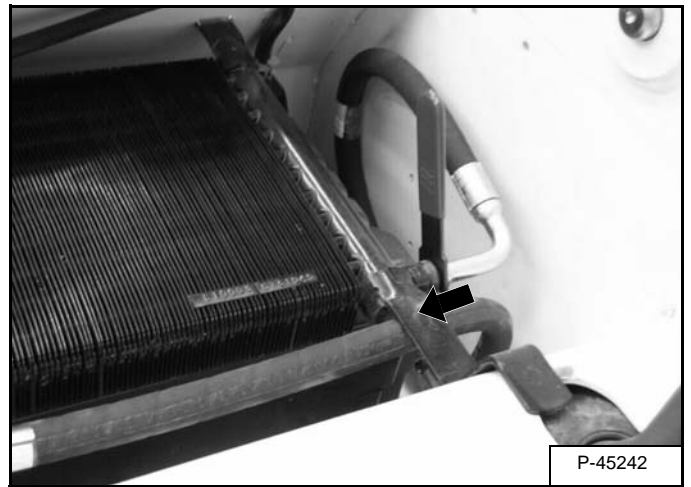

Figure 20-100-3



Slide the rubber sleeve in toward the radiator. The connector will release [Figure 20-100-2] and [Figure 20-100-3].

REAR AUXILIARY DIVERTER VALVE (CONT'D)

Removal And Installation (Cont'd)

Figure 20-120-3

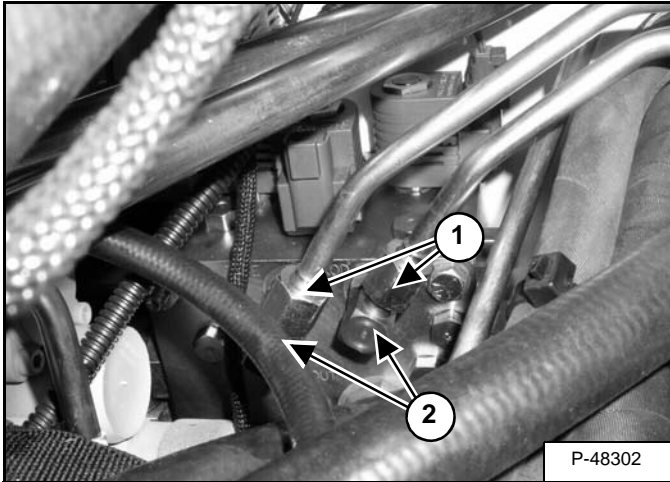

Disconnect the base and rod end tubelines (Item 1) [Figure 20-120-3].

Remove the fittings (Item 2) [Figure 20-120-3] from the valve.

Figure 20-120-4

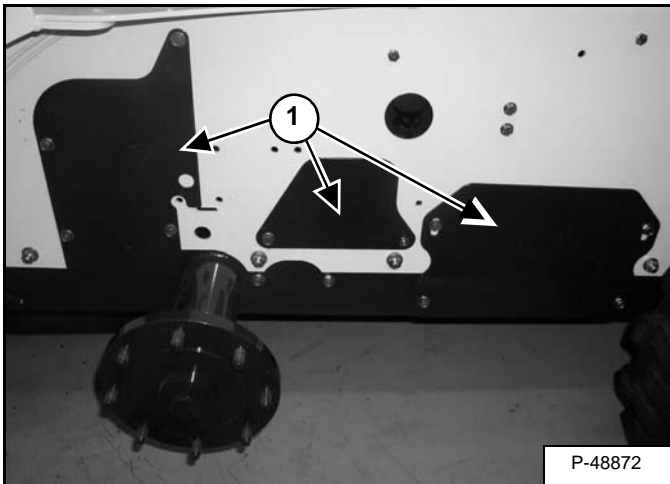

Remove the three access covers (Item 1) [Figure 20-120-4] on the right side of the machine.

Figure 20-120-5

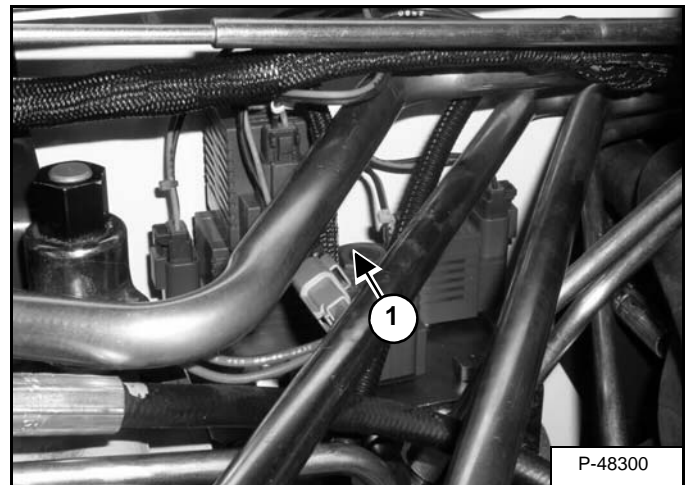

Disconnect the four solenoid connectors (Item 1) [Figure 20-120-5] from the rear auxiliary valve.

Figure 20-120-6

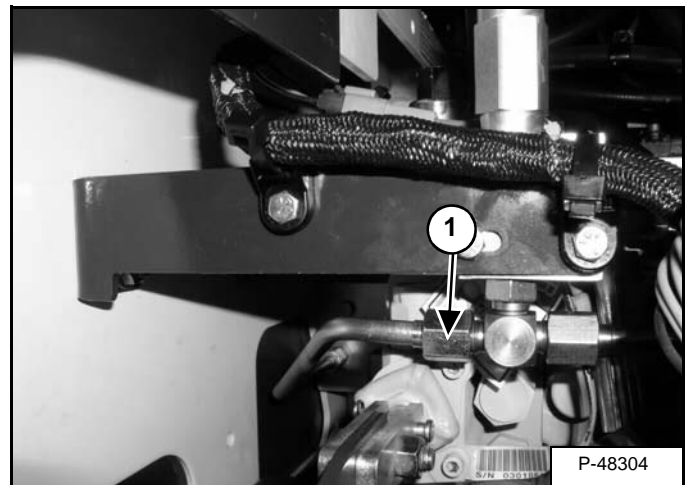

Disconnect the drain tubeline (Item 1) [Figure 20-120-6] from the lift arm by pass valve.

BOB-TACH (POWER) BLOCK (CONT'D)

Disassembly And Assembly

Figure 20-130-5

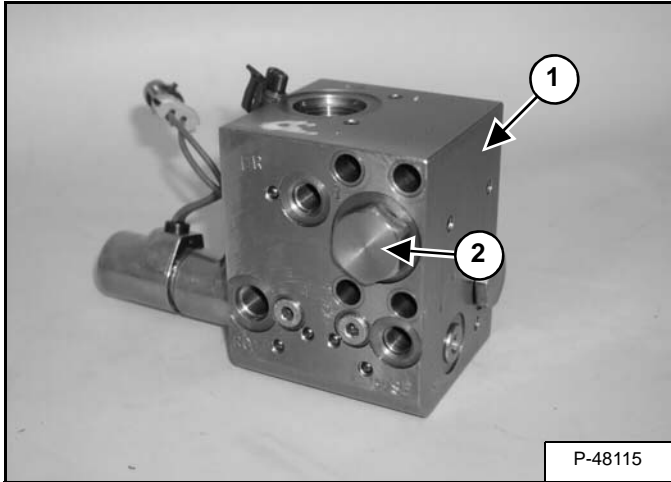

Clean the block (Item 1) [Figure 20-130-5] to remove dirt before disassembly. Block ports are labeled for correct assembly.

Remove the plug (Item 2) [Figure 20-130-5].

Assembly: Tighten the plug to 34 - 40,6 N•m (25 - 30 ft-lb) torque.

IMPORTANT

When repairing hydrostatic and hydraulic systems, clean the work area before disassembly and keep all parts clean. Always use caps and plugs on hoses, tubelines and ports to keep dirt out. Dirt can quickly damage the system.

I-2003-0888

Figure 20-130-6

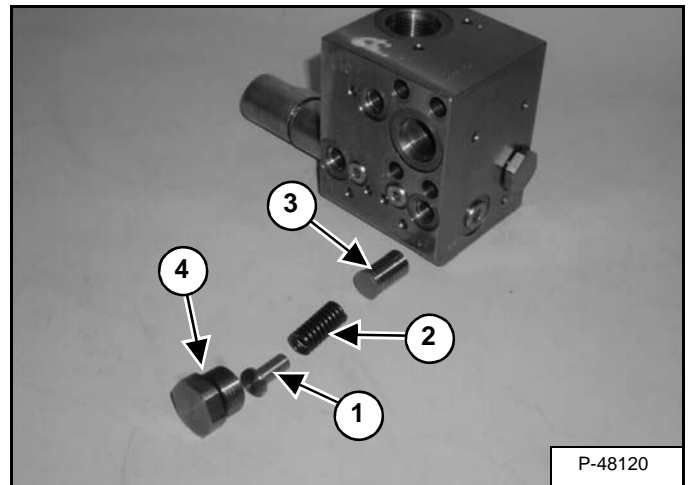

Remove the spring guide (Item 1), spring (Item 2) and the spool (Item 3) [Figure 20-130-6].

Inspect the O-ring (Item 4) [Figure 20-130-6] on the plug and replace as needed.

Figure 20-130-7

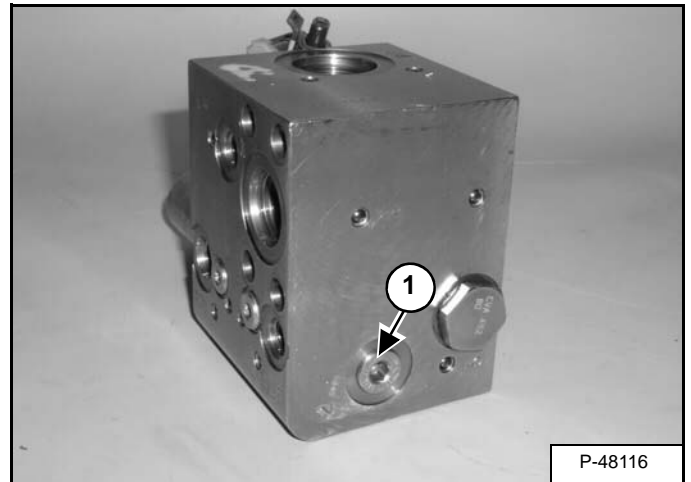

NOTE: This plug is a zero leak plug and should not be removed. If removed damage may occur and the plug and O-ring must be replaced.

Do not remove the plug (Item 1) [Figure 20-130-7].

Assembly: Tighten the plug to 16,3 - 19 N•m (12 - 14 ft-lb) torque.

HIGH FLOW VALVE (CONT'D)

Removal And Installation (Cont'd)

Figure 20-150-10

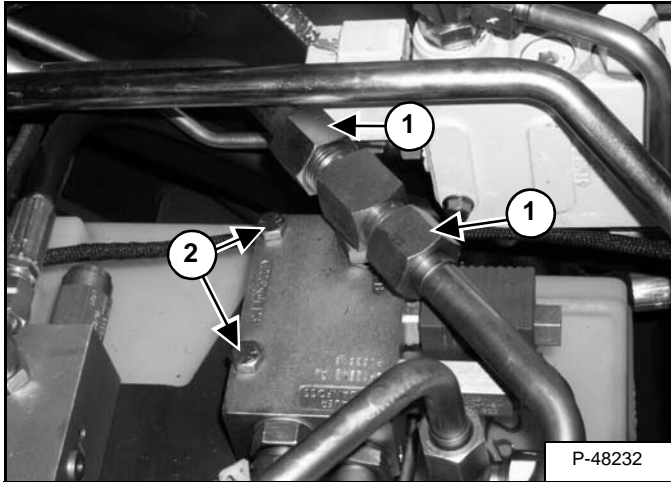

Disconnect and cap the tubelines (Item 1) [Figure 20-150-10] to the tilt cylinders.

Remove the two mounting bolts (Item 2) [Figure 20-150-10].

Installation: Tighten the mounting bolts to 34 - 38 N•m (25 - 28 ft-lb) torque.

Disassembly And Assembly

Figure 20-150-11

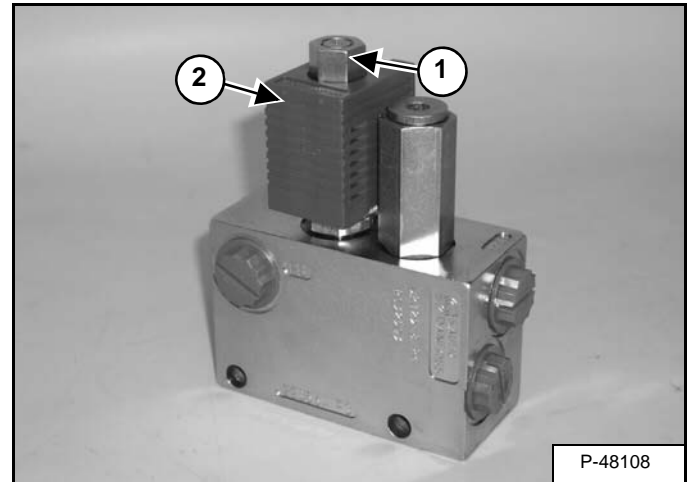

Remove the solenoid nut (Item 1) and solenoid (Item 2) [Figure 20-150-11] from the solenoid valve.

Assembly: Tighten to 5 - 8 N•m (4 - 6 ft-lb) torque.

Figure 20-150-12

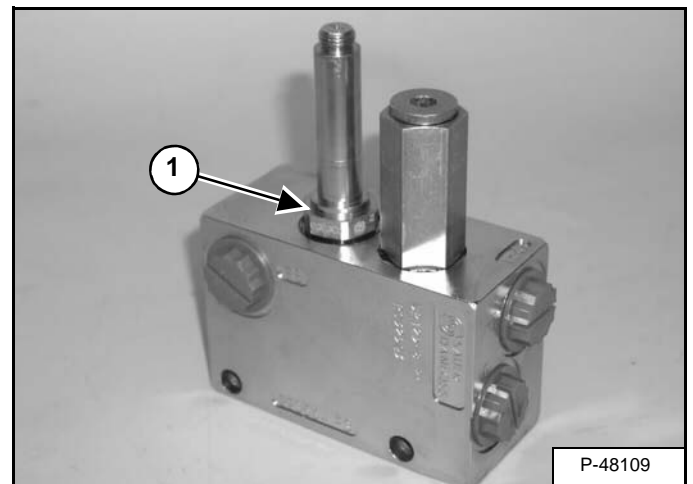

Remove the solenoid valve (Item 1) [Figure 20-150-12] from the valve.

Assembly: Tighten to 41 - 47 N•m (30 - 35 ft-lb) torque.

HYDROSTATIC DRIVE MOTOR (CONT'D)

Removal And Installation (Cont'd)

Figure 30-20-5

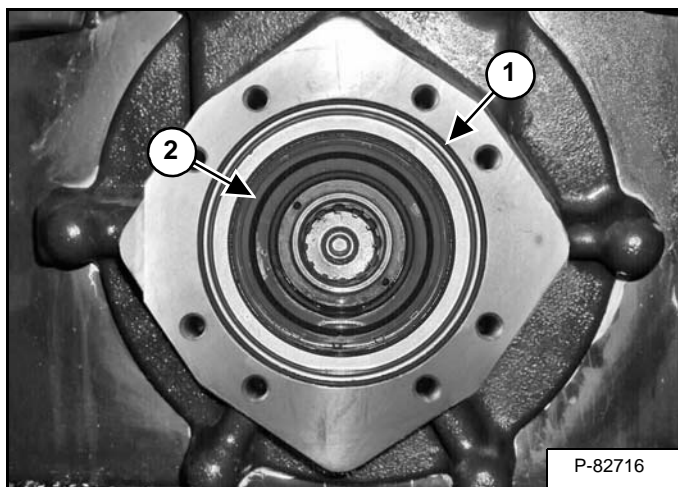

Remove the hydrostatic motor from the access hole in the loader frame **[Figure 30-20-5]**.

Inspect hydrostatic motor O-ring (Item 1) and carrier shaft seal (Item 2) **[Figure 30-20-5]**.

Reverse the removal procedure to install the hydrostatic motor.

HYDROSTATIC DRIVE MOTOR (TWO-SPEED) (CONT'D)

Removal And Installation (Left Side) (Cont'd)

Figure 30-21-3

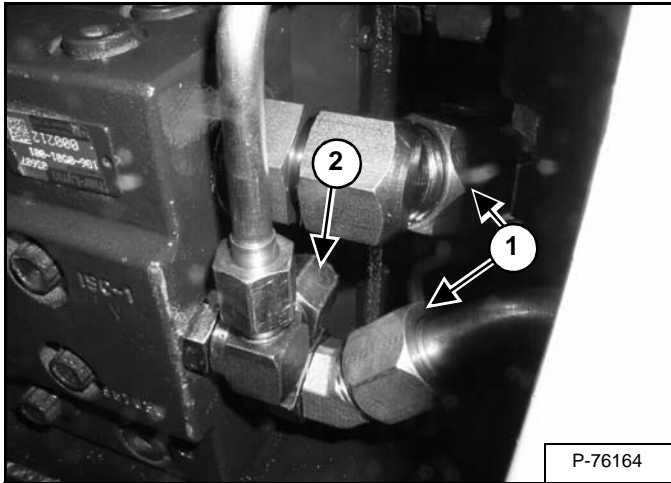

Mark the hoses and tubeline for correct installation.

Disconnect both high pressure hydraulic tubelines (Item 1) [Figure 30-21-3] from the motor.

Disconnect the pre-warming tubeline (Item 2) [Figure 30-21-3] from the motor.

Figure 30-21-4

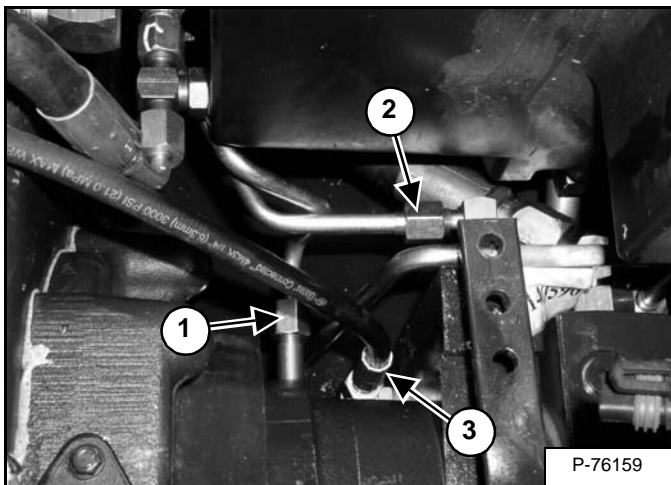

Mark the hose and tubelines for correct installation.

Disconnect the case drain tubeline (Item 1) [Figure 30-21-4] from the motor.

Disconnect the shift pressure tubeline (Item 2) [Figure 30-21-4] from the motor.

Disconnect the hose (Item 3) [Figure 30-21-4] from the motor.

Figure 30-21-5

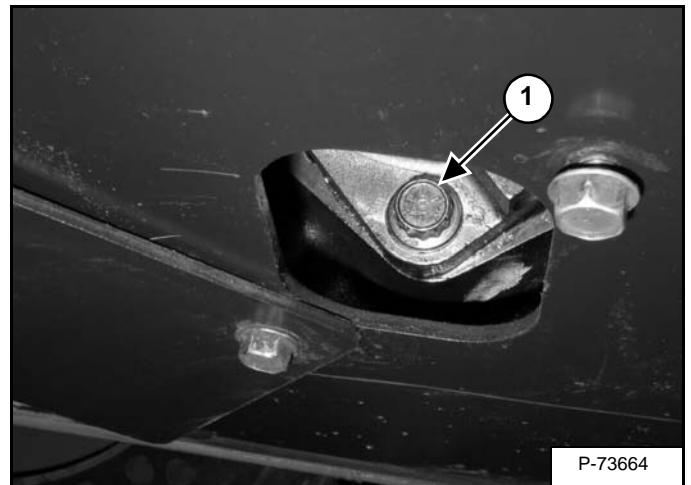

Remove the lower mounting bolt (Item 1) [Figure 30-21-5] from the motor.

Installation: Tighten the mounting bolt to 285 N•m (210 ft-lb) torque.

Figure 30-21-6

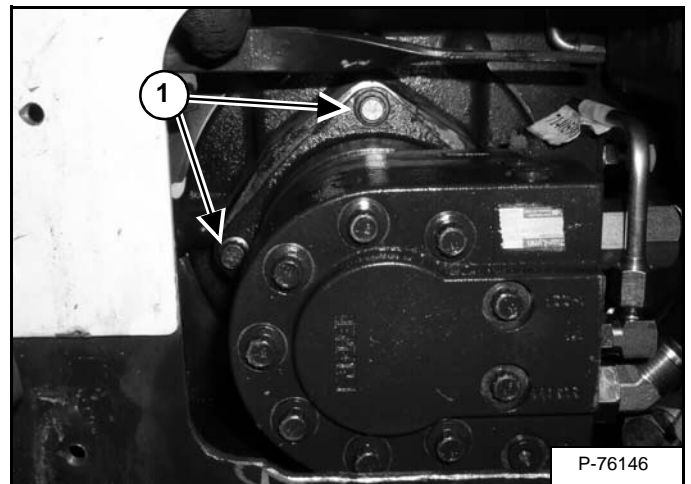

Remove two mounting bolts (Item 1) [Figure 30-21-6] from the motor.

Installation: Tighten the mounting bolts to 285 N•m (210 ft-lb) torque.

Remove the motor from the access hole in the loader frame.

HYDROSTATIC DRIVE MOTOR (TWO-SPEED) (CONT'D)

Disassembly (Cont'd)

Figure 30-21-34

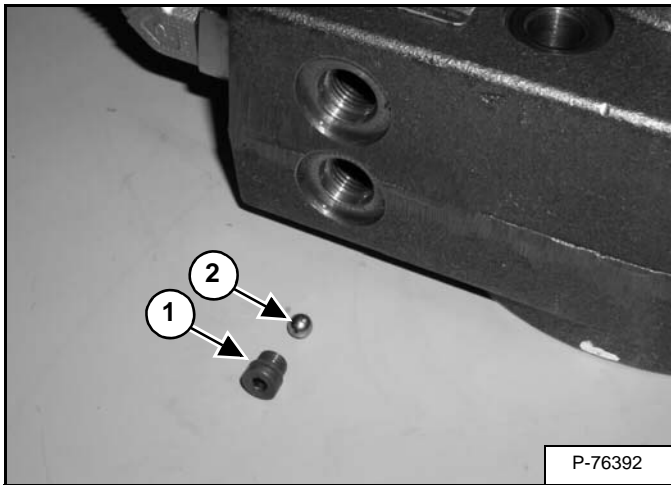

Remove the ball seat (Item 1) and ball (Item 2) [Figure 30-21-34] from the valve housing.

NOTE: To remove the ball seat, use a long allen wrench to reach down into the valve housing.

Figure 30-21-35

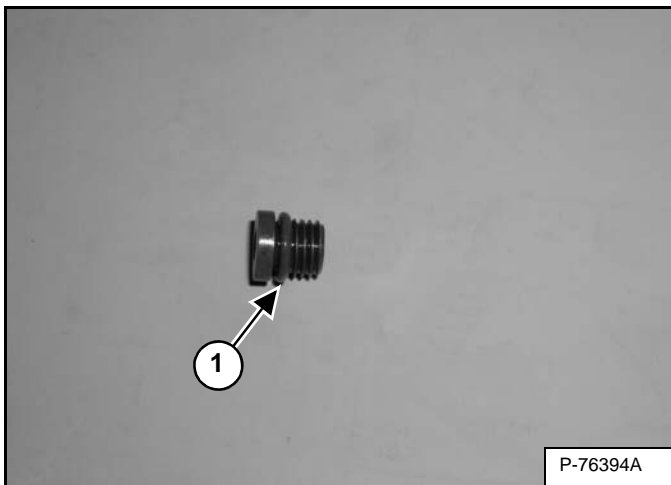

Remove O-ring (Item 1) [Figure 30-21-35] on plug.

Figure 30-21-36

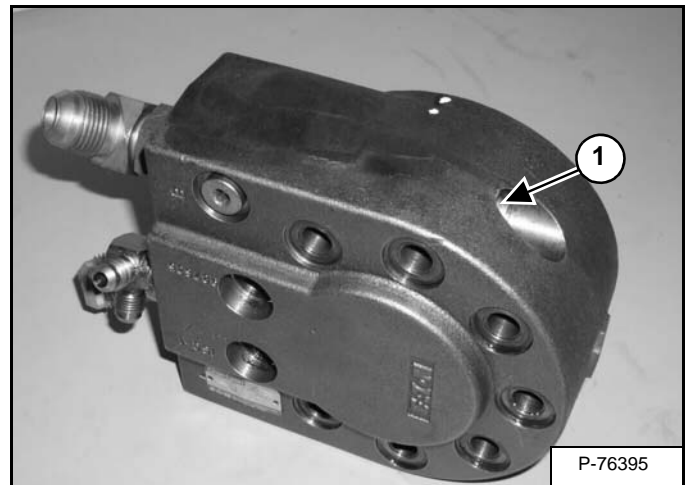

Remove the plug (Item 1) [Figure 30-21-36] from the valve housing.

Figure 30-21-37

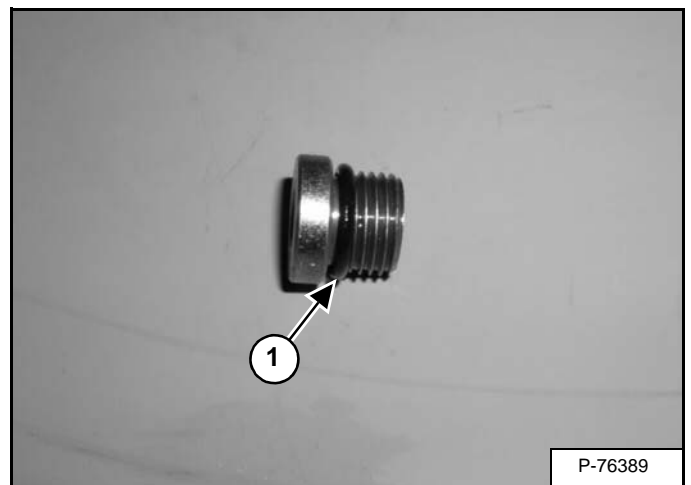

Remove O-ring (Item 1) [Figure 30-21-37] on plug.

HYDROSTATIC DRIVE MOTOR (TWO-SPEED) (CONT'D)

Assembly (Cont'd)

Motor Timing (Cont'd)

Figure 30-21-71

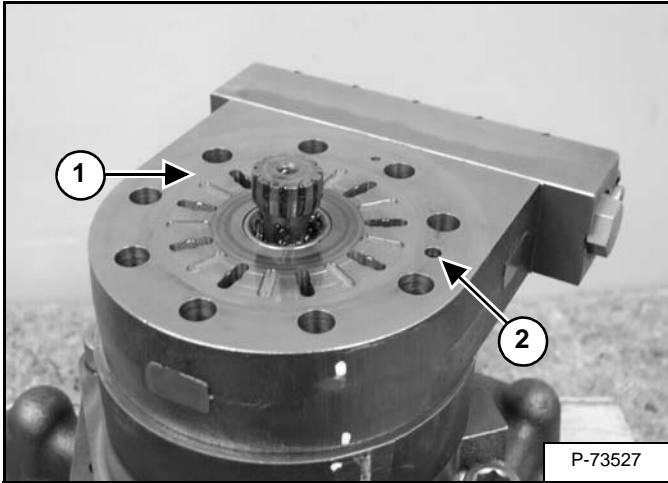

Install the selector plate (Item 1) with the slotted holes facing up. Be sure to line up the shuttle flow hole (Item 2) [Figure 30-21-71].

Figure 30-21-72

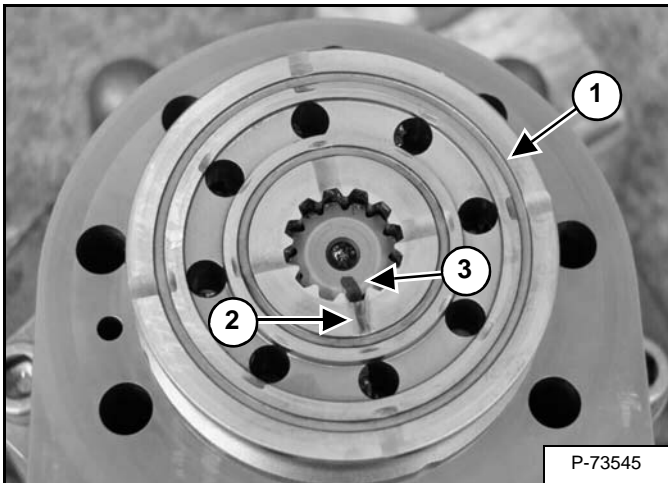

Install the valve (Item 1) [Figure 30-21-72] on the valve drive. The round holes and four grooves must be facing up.

Align any one of the four grooves (Item 2) in the valve with the marked tooth on the valve drive (Item 3) [Figure 30-21-72].

Figure 30-21-73

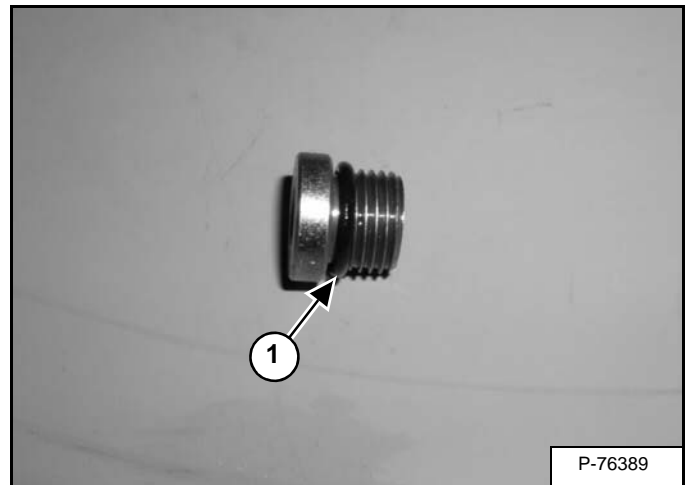

Install new O-rings (Item 1) [Figure 30-21-73] on both plugs.

Figure 30-21-74

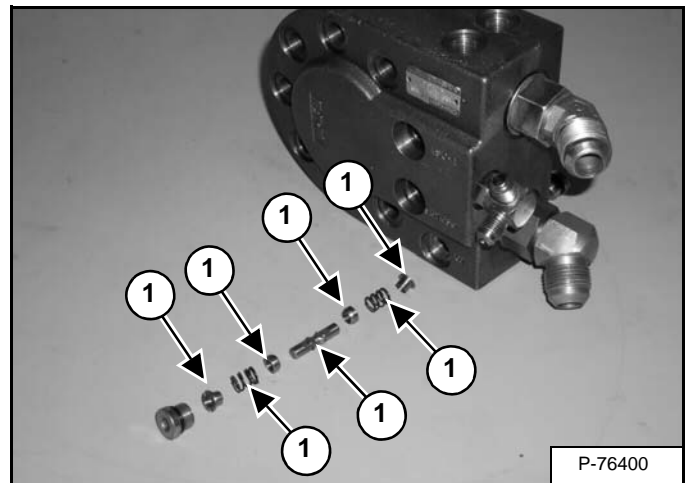

Assemble the shuttle valve assembly (Item 1) [Figure 30-21-74] and insert into the valve housing.

HYDROSTATIC MOTOR CARRIER (SINGLE AND TWO-SPEED WITH MANUAL CONTROLS) (CONT'D)

Shaft Seal Removal And Installation (Cont'd)

Figure 30-30-6

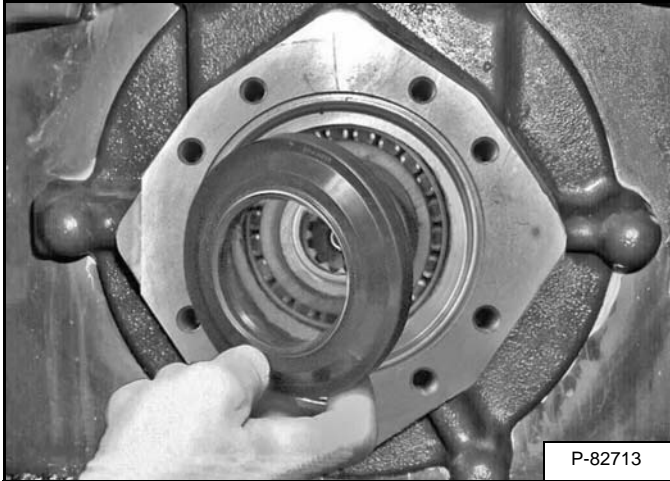

Installation: Install a new seal over the motor carrier shaft [Figure 30-30-6].

Figure 30-30-7



Installation: Install MEL1420 Carrier Seal Tool over the carrier seal [Figure 30-30-7].

Hit the tool with a hammer until the seal is fully seated on the carrier shaft [Figure 30-30-7].

Figure 30-30-8

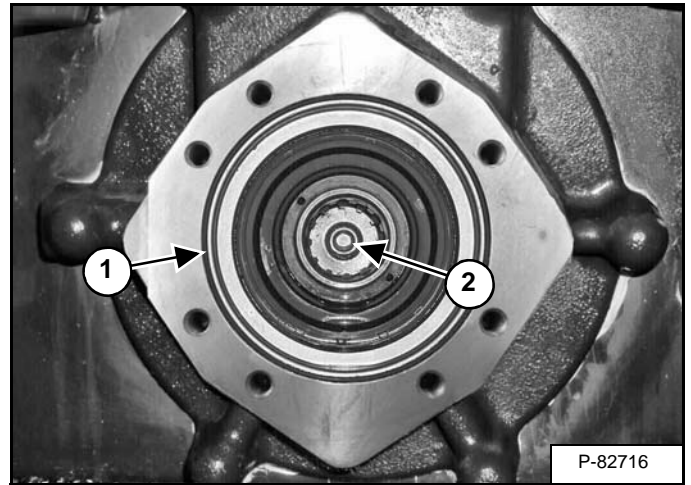

Photo [Figure 30-30-8] shows the motor carrier seal correctly installed.

Inspect the O-ring (Item 1) [Figure 30-30-8] and replace if needed.

NOTE: Before reinstalling the hydrostatic motor, check the plug (Item 2) [Figure 30-30-8] located in the center of the carrier shaft for tightness. If the plug becomes loosened, case drain lubrication oil from the hydrostatic motor can leak into the chaincase.

HYDROSTATIC MOTOR CARRIER (SINGLE AND TWO-SPEED WITH SJC CONTROLS)

Description

The hydrostatic motor carrier is the mating connection from the hydrostatic drive motor to the transmission case.

The hydrostatic motor carrier contains a shaft that rotates on two tapered roller bearings. The shaft has two sprockets that turn the drive chains.

The hydrostatic motor carrier has a seal which isolates the chain case oil from the hydrostatic motor case drain oil.

Loaders equipped with Selectable Joystick Controls (SJC) use a speed sensor installed in the motor carrier housing. The speed sensor senses a disk that is fixed to the shaft in the motor carrier. If the loader does not have (SJC), a plate covers the hole where the sensor would be.

A brake disk is installed on each hydrostatic motor carrier. The brake disk is mounted to the shaft in the motor carrier.

The hydrostatic motor carriers are made to fit on both the right or left hand side of the loader. There are two sets of mounting holes on each hydrostatic motor carrier to fasten the hydrostatic motors. One set for the left hand side and another set for the right hand side of the loader.

Figure 30-31-1

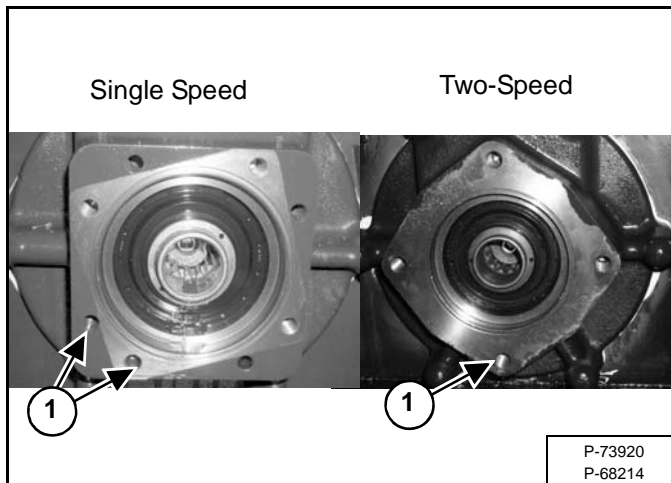
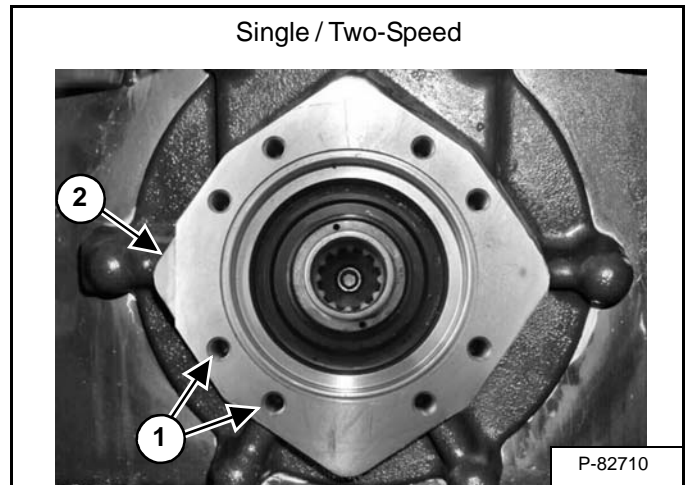

Figure 30-31-2



The motor carrier hydrostatic motor mounting holes (Item 1) [Figure 30-31-1] and [Figure 30-31-2] are the only difference between the single, two-speed and single / two-speed motor carriers with SJC controls. The disassembly and assembly procedures are the same.

The single / two speed motor carrier has a notch (Item 2) [Figure 30-31-2] removed from one side of the carrier.

HYDROSTATIC MOTOR CARRIER (SINGLE AND TWO-SPEED WITH SJC CONTROLS) (CONT'D)

Disassembly And Assembly (Cont'd)

Figure 30-31-27

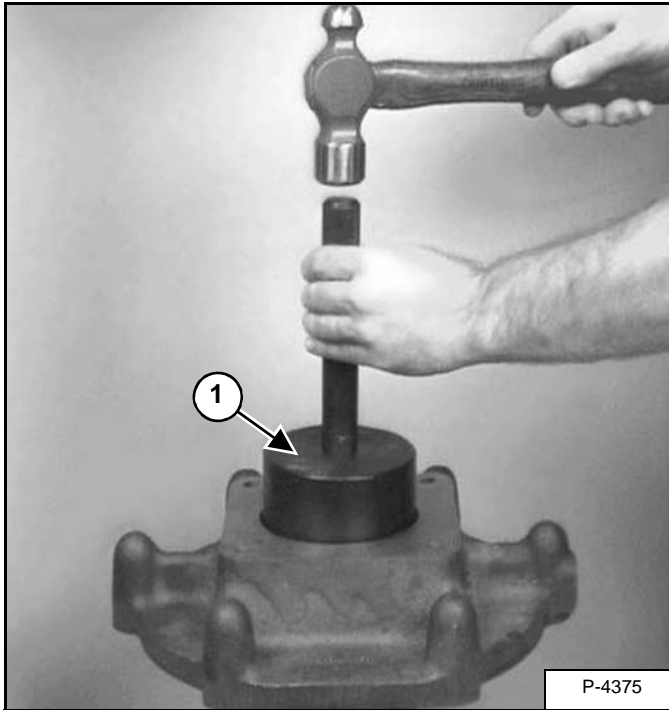

Use MEL1420 Carrier Seal Tool (Item 1) [Figure 30-31-27] and install the shaft seal.

Hit the tool with a hammer until the seal is fully seated on the carrier shaft [Figure 30-31-27].

Figure 30-31-28

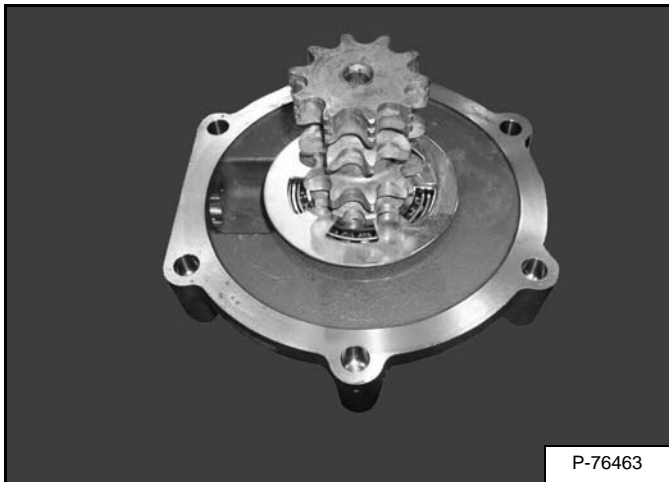

Use a rubber mallet [Figure 30-31-28], tap down on the cluster shaft.

Figure 30-31-29

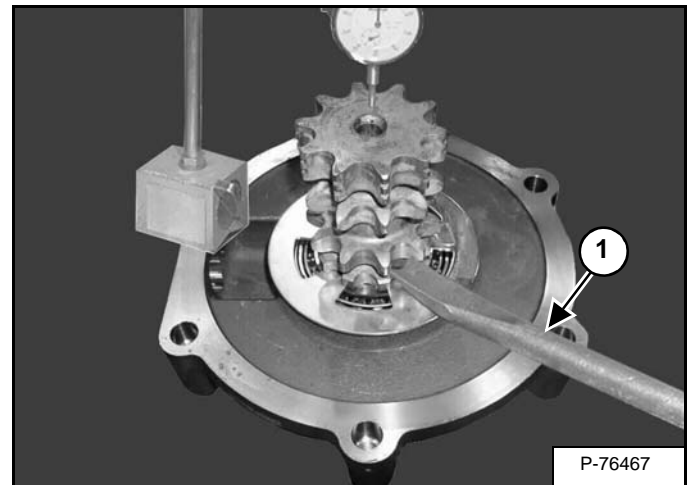

Install a dial indicator as shown in Photo [Figure 30-31-29].

Use a pry bar (Item 1) [Figure 30-31-29] to lift the carrier shaft and read the end play on the dial indicator.

The carrier shaft must turn freely with end play not to exceed 0,17 mm (0.007 in).

HYDROSTATIC PUMP

Description

The hydrostatic pump is composed of two hydrostatic piston pumps connected together. The pumps provide bi-directional flow to two separate hydrostatic drive motors. The pump flow and direction are controlled by two hand levers, one for each pump.

The hydrostatic pump contains replenishing valves. The function of these valves is to give replacement fluid to the low pressure side of the hydrostatic circuit. Replacement fluid is needed because of normal internal leakage and the controlled flow to the oil cooler for cooling. Another function of the replenishing valve is to keep high pressure fluid out of the low pressure side of the hydrostatic circuit.

The hydrostatic pump contains the charge pressure relief. The charge pressure relief is adjustable with shims.

The hydrostatic pump is located in the center of the mainframe mounted to the engine flywheel housing.

Replenishing / High Pressure Relief Valve Removal And Installation

Figure 30-50-1

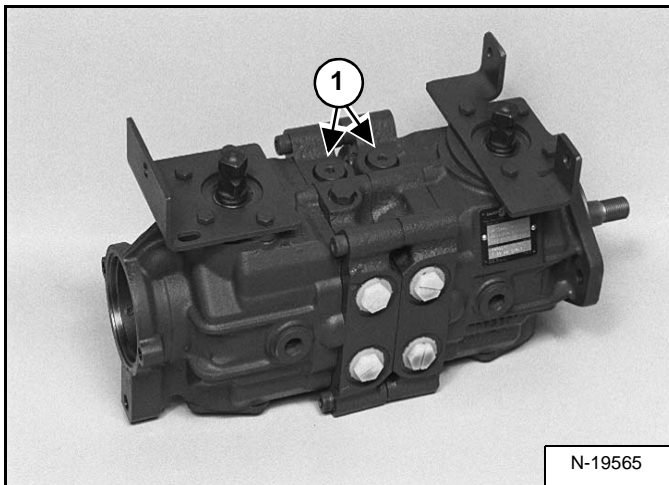

There are four replenishing / high pressure relief valves (Item 1) [Figure 30-50-1] in the hydrostatic pump assembly. Two are located at the top of the pumps and two at the bottom of the pumps.

NOTE: The two top valves are for the reverse drive loop and the two bottom valves are for the forward drive loop.

Figure 30-50-2

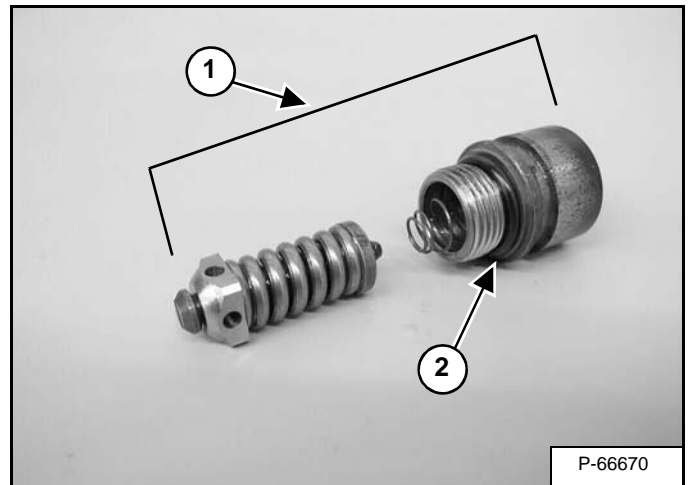

Remove the replenishing / high pressure relief valve (Item 1) [Figure 30-50-2] from the pump.

Assembly: Tighten the plug to 41 - 68 N•m (30 - 50 ft-lb) torque.

Check for damage and replace as needed.

Check the O-ring (Item 2) [Figure 30-50-2] for damage and replace as needed.

If the replenishing / high pressure relief valve must be replaced, it must be replaced as a complete unit.

The pressure setting for a new replenishing / high pressure relief valve is 34473,8 kPa (344,7 bar) (5000 psi).

HYDROSTATIC PUMP (CONT'D)

Disassembly (Cont'd)

Figure 30-50-27

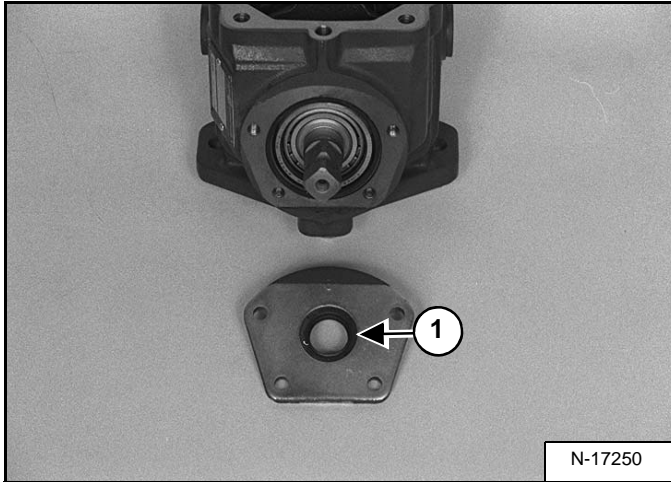

Inspect the seal (Item 1) [Figure 30-50-27] in the upper trunnion cover and replace if needed.

Figure 30-50-28

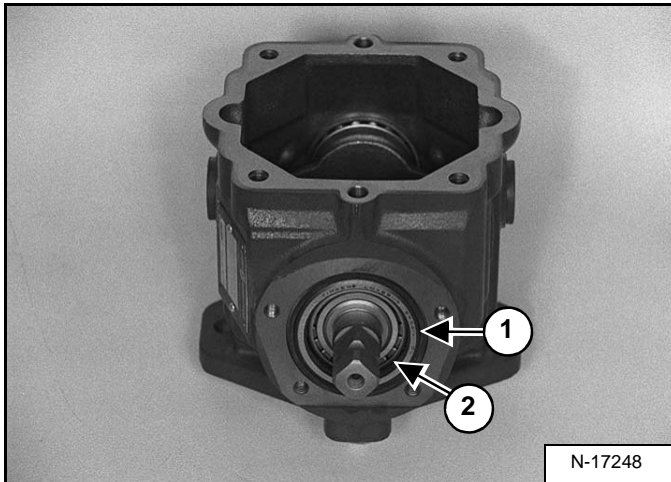

Remove the O-ring (Item 1) and bearing race (Item 2) [Figure 30-50-28] from the pump housing.

Figure 30-50-29

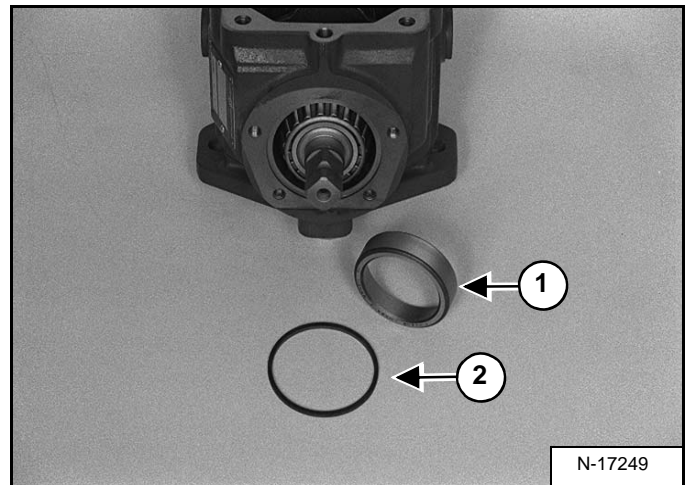

Inspect the bearing race (Item 1) and O-ring (Item 2) [Figure 30-50-29] and replace as needed.

Figure 30-50-30

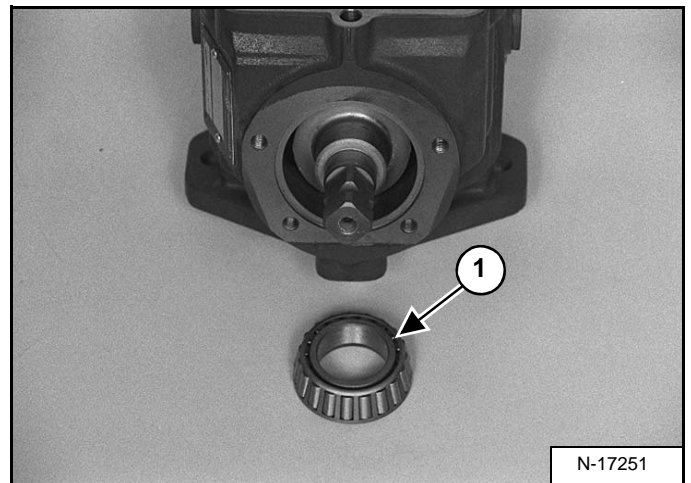

Slide the swash plate from side to side and remove the tapered roller bearing (Item 1) [Figure 30-50-30] from the swash plate shaft.

HYDROSTATIC PUMP (SJC) (CONT'D)

Hydraulic Controller Removal And Installation (Cont'd)

Figure 30-51-5

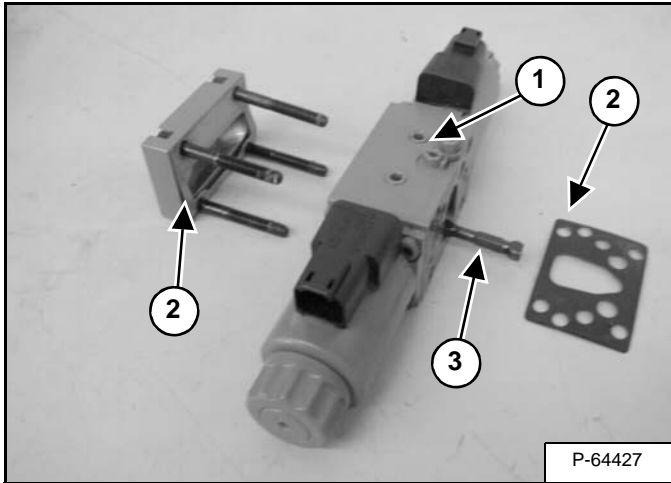

Remove the controller (Item 1) [Figure 30-51-5] from the pump.

Remove the controller gaskets (Item 2) [Figure 30-51-5] from the pump.

Installation:

Figure 30-51-6

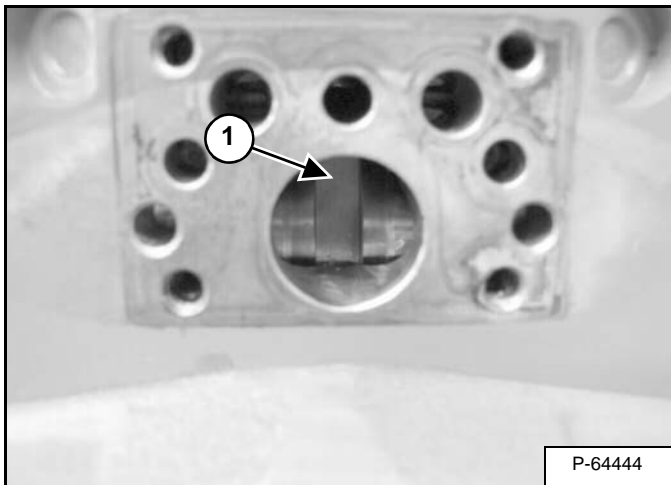

Be sure the feedback lever (Item 3) [Figure 30-51-5] is in the center of the servo piston groove (Item 1) [Figure 30-51-6].

Use a small amount of grease on a new gasket and install the gasket on the hydraulic controller (Item 1) [Figure 30-51-5].

Be sure the pump surface is clean.

Figure 30-51-7

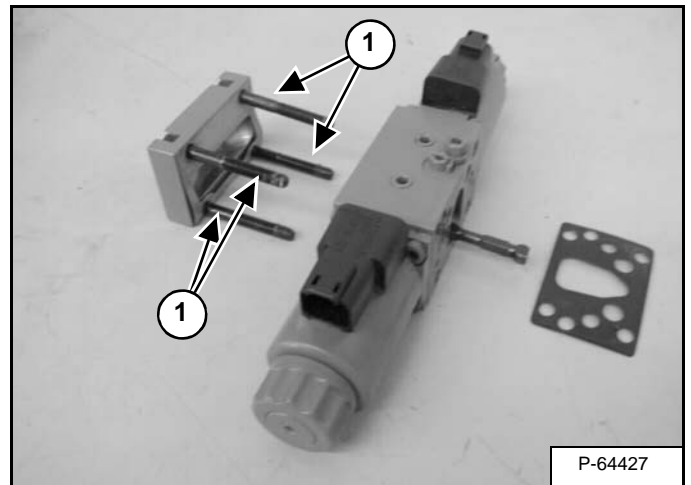

Alternately tighten bolts (Item 1) [Figure 30-51-7] to 10,4 N•m (7.7 ft-lb) torque. Ensure bolts are tight to specifications.

NOTE: When a hydraulic controller is replaced, the hydrostatic pumps must be calibrated. (See Hydraulic Controller Neutral Adjustment on Page 30-51-29.)

Figure 30-51-8

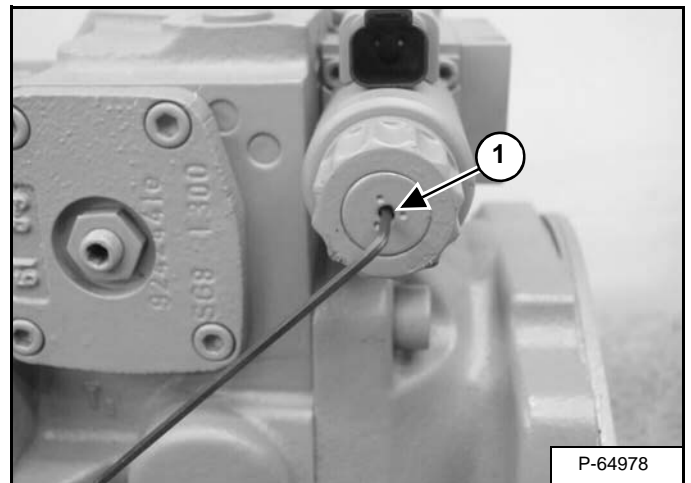

With the engine running and the loader on jack stands: Bleed the trapped air in the controller by loosening the small set screw (Item 1) [Figure 30-51-8] a maximum of 2 turns. Leave the screw loose until oil comes dripping out of the set screw. Tighten set screw to 2 N•m (18 in-lb) torque.

Repeat the bleeding procedure for all of the solenoids.

HYDROSTATIC PUMP (SJC) (CONT'D)

Disassembly And Assembly (Cont'd)

Figure 30-51-32

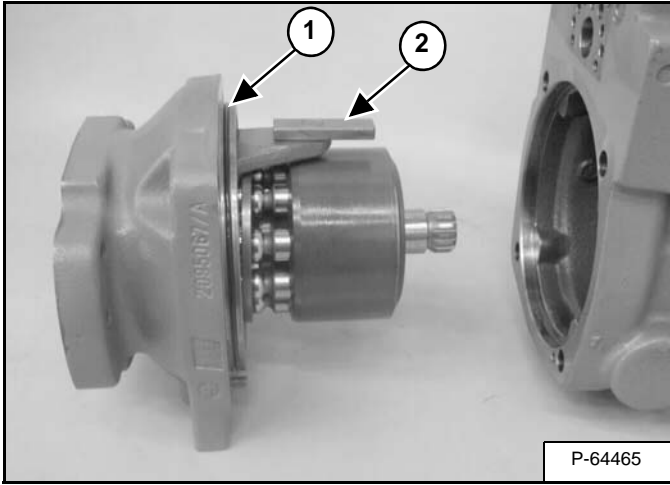

Replace O-ring (Item 1) [Figure 30-51-32].

Figure 30-51-33

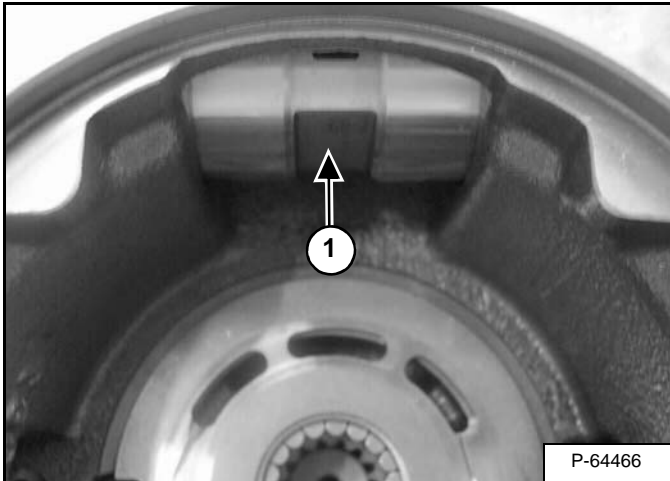

Ensure servo follower (Item 2) [Figure 30-51-32] is swung out for proper engagement with the notch in the servo piston (Item 1) [Figure 30-51-33].

Figure 30-51-34

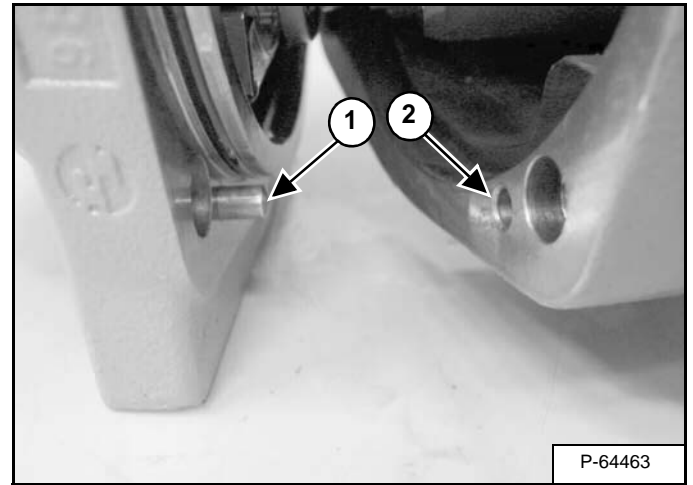

Assembly: Ensure dowel pin (Item 1) is aligned with hole in case housing (Item 2) [Figure 30-51-34] before tightening screws.

HYDROSTATIC PUMP (SJC) (CONT'D)

Disassembly And Assembly (Cont'd)

Figure 30-51-67

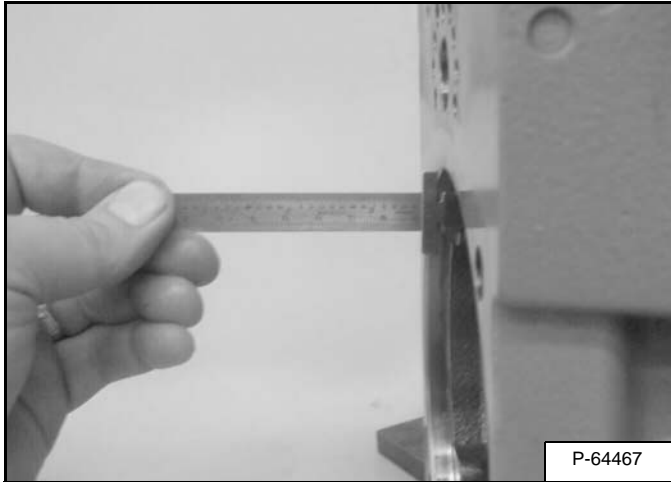
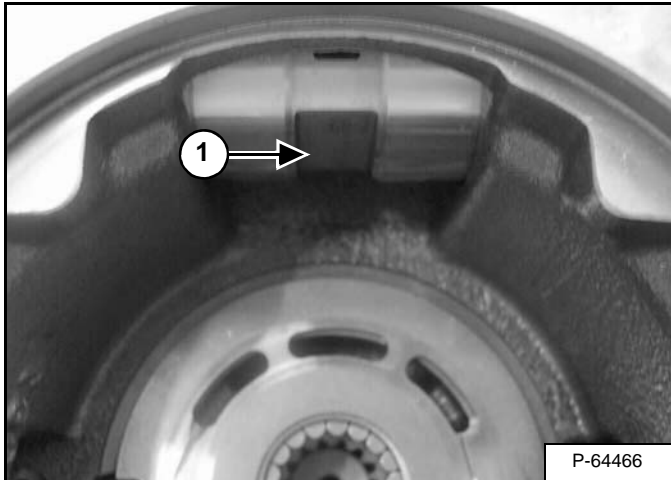
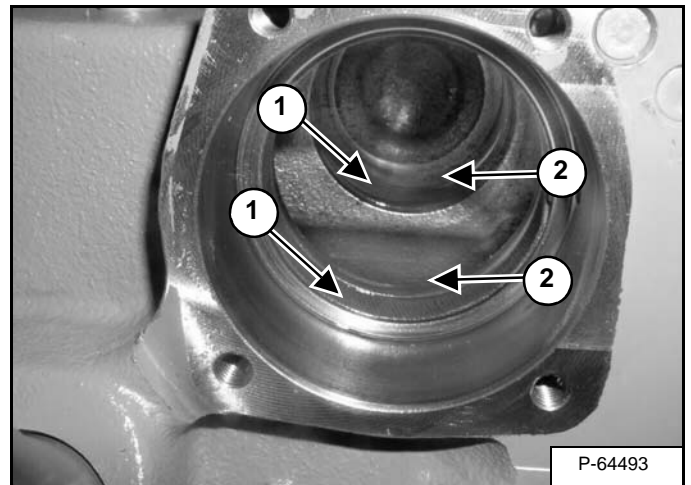

Figure 30-51-68



Assembly: Align the servo piston so the guide slot (Item 1) [Figure 30-51-68] is parallel to the driveshaft centerline. Measure with a straight-edge [Figure 30-51-67].

Figure 30-51-69



Remove the bushings (Item 1), seals and O-rings (Item 2) [Figure 30-51-69] from the pump housing.

Figure 30-51-70

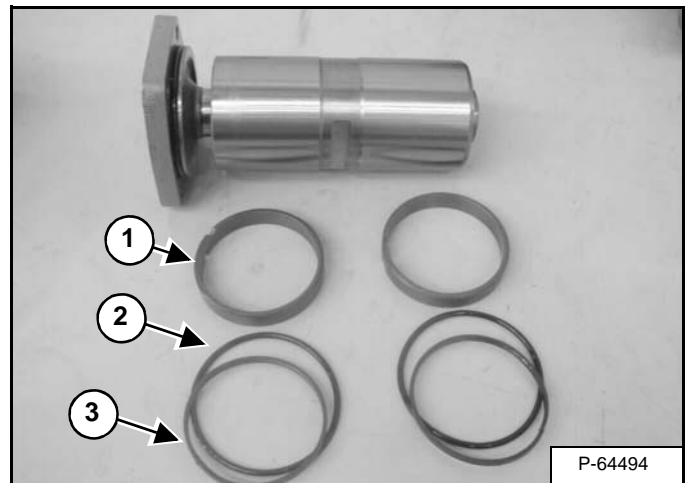

Each servo has a pair of bushings (Item 1), O-rings (Item 2) and square-cut seals (Item 3) [Figure 30-51-70].

DRIVE BELT

Description

The drive belt makes the mechanical connection from the engine flywheel to the hydrostatic pump pulley.

The belt is a cord-reinforced rubber design.

Constant tension is applied to the drive belt by the use of a spring-loaded belt tensioner.

The drive belt is protected by a plastic shield fastened to the flywheel housing by metal clips. The shield is also in place to protect the operator.

Shield Removal And Installation

Figure 30-60-1

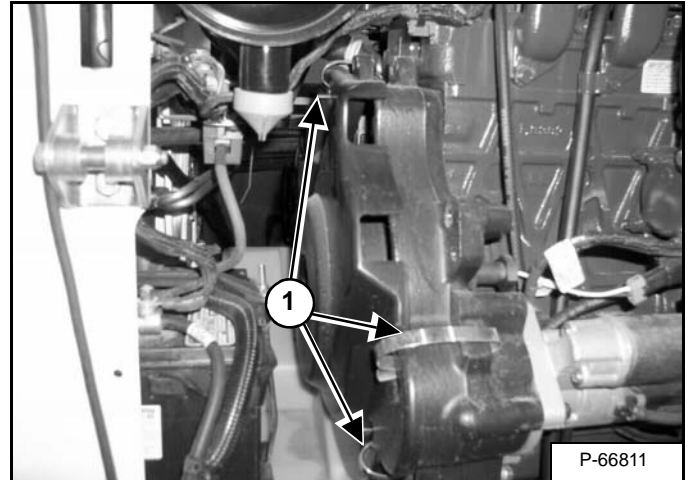

Remove the three drive belt shield mounting clips (Item 1) [Figure 30-60-1].

Figure 30-60-2

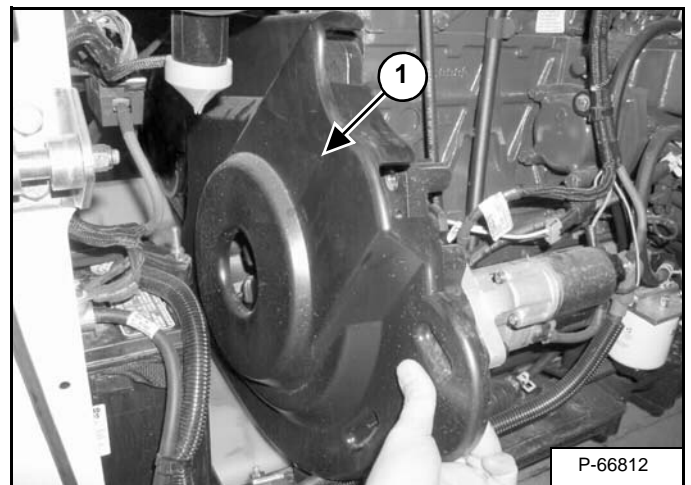

Remove the belt shield (Item 1) [Figure 30-60-2].

TWO-SPEED VALVE (CONT'D)

Valve Removal And Installation (Cont'd)

Figure 30-70-4

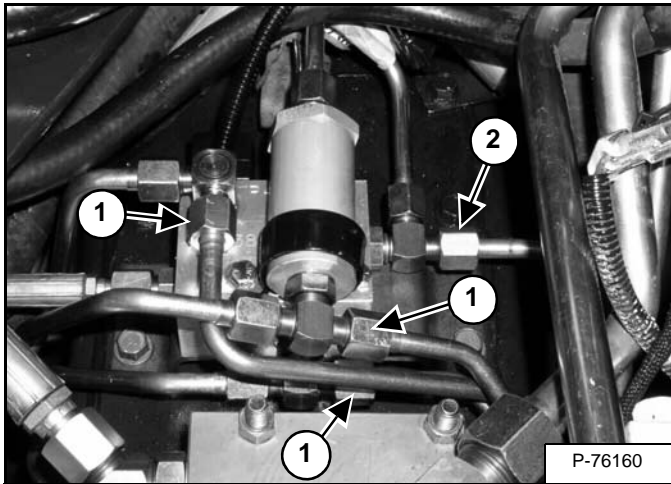

Disconnect the three hydraulic tubelines (Item 1) [Figure 30-70-4] from the two-speed valve.

Disconnect the hydraulic hose (Item 2) [Figure 30-70-4] from the two-speed valve.

Figure 30-70-5

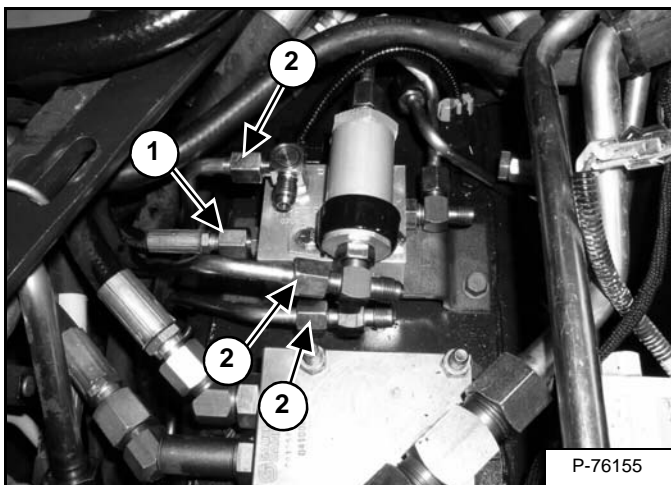

Disconnect the hydraulic hose (Item 1) and the three tubelines (Item 2) [Figure 30-70-5] from the two-speed valve.

Figure 30-70-6

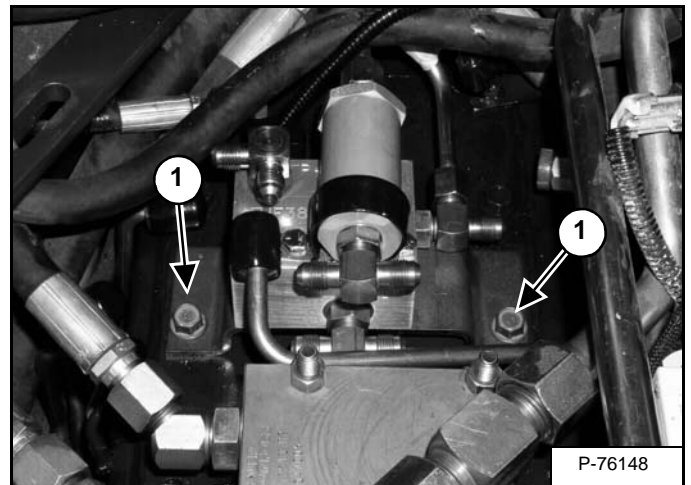

Remove the two mounting bolts (Item 1) [Figure 30-70-6] from the valve bracket.

Remove the two-speed valve assembly from the loader.

BRAKE (TWO-SPEED)

Description

The brake discs on two-speed loaders have a rubber isolator riveted to the side of the brake discs.

The brake is used to hold the machine in place. The brake is operated by a switch (Item 1) [Figure 40-11-1] located on the front accessory panel.

The brake is applied by a spring-loaded wedge that drops into two notched brake discs attached to the motor carrier shafts. An electric solenoid is sent power from a relay to pull the wedge away from the discs. A signal from the main Bobcat controller holds the wedge away from the discs.

The hold signal will be interrupted and the wedge will drop if the engine drops below 700 , the seat bar sensor fails or if there is a break in the wires for the brake solenoid.

For more information on the brake. (See TRACTION LOCK on Page 60-120-1.)

Figure 40-11-1

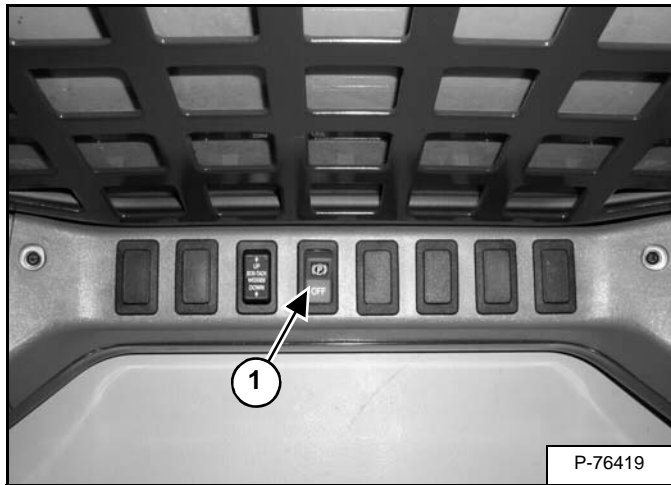

Disc Removal And Installation

Raise the loader lift arms and install an approved lift arm support device. (See Installing on Page 10-20-1.)



Never work on a machine with the lift arms up unless the lift arms are secured by an approved lift arm support device. Failure to use an approved lift arm support device can allow the lift arms or attachment to fall and cause injury or death.

W-2059-0598

Raise the loader operator cab. (See Raising on Page 10-30-1.)

Disconnect and remove the engine speed control. (See Removal And Installation on Page 70-20-1.)

Remove the control panel from the loader. (See Removal And Installation on Page 50-100-2.)

Remove the center chaincase cover. (See Center Cover Removal And Installation on Page 40-30-2.)

Remove the traction lock assembly. (See Removal And Installation on Page 60-120-2.)

Figure 40-11-2

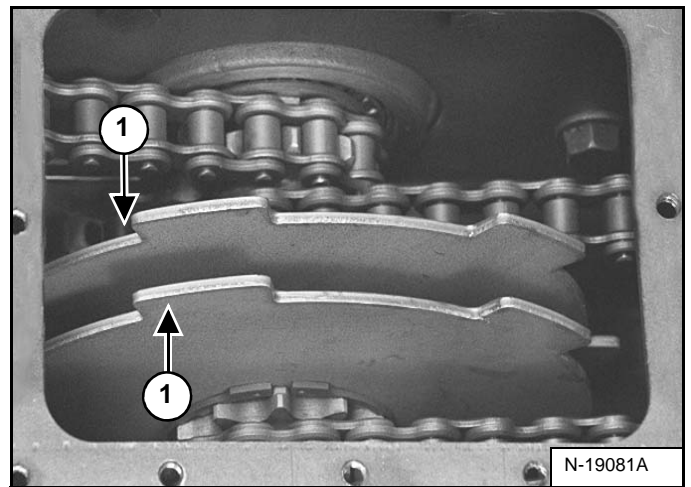

The parking brake discs (Item 1) [Figure 40-11-2] are located beneath the center chaincase cover.

Figure 40-11-3

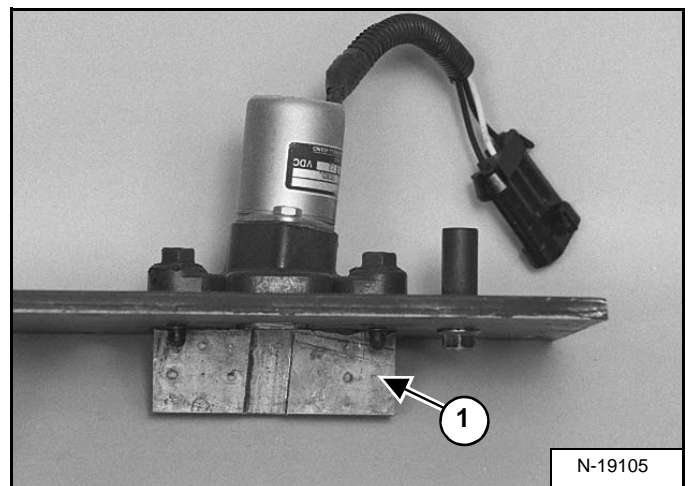

Inspect the traction lock guides (Item 1) [Figure 40-11-3] and the brake disc for damage or wear and replace as necessary. (See Inspecting on Page 60-120-6.)

CLICK HERE TO **DOWNLOAD** THE COMPLETE MANUAL

- Thank you very much for reading the preview of the manual.
- You can download the complete manual from: www.heydownloads.com by clicking the link below



- Please note: If there is no response to CLICKING the link, please download this PDF first and then click on it.

CLICK HERE TO **DOWNLOAD** THE COMPLETE MANUAL

DRIVE COMPONENTS (CONT'D)

Chain Removal And Installation

! WARNING

Never work on a machine with the lift arms up unless the lift arms are secured by an approved lift arm support device. Failure to use an approved lift arm support device can allow the lift arms or attachment to fall and cause injury or death.

W-2059-0598

Raise the loader lift arms and install an approved lift arm support device. (See Installing on Page 10-20-1.)

Lift and block the loader. (See Procedure on Page 10-10-1.)

Raise the loader operator cab. (See Raising on Page 10-30-1.)

Drain the fluid from the chaincase. (See Removing And Replacing Oil on Page 10-130-1.)

Remove the engine speed control. (See Removal And Installation on Page 70-20-1.)

Remove the control panel. (See Removal And Installation on Page 50-100-2.)

Remove the traction lock assembly. (See Removal And Installation on Page 60-120-2.)

Remove the center chaincase cover. (See Center Cover Removal And Installation on Page 40-30-2.)

Remove the front (or rear) chaincase cover. (See Front Cover Removal And Installation on Page 40-30-1.)

Remove the front (or rear) axle and sprocket. (See Axle, Sprocket And Bearings Removal And Installation on Page 40-20-4.)

Figure 40-20-20

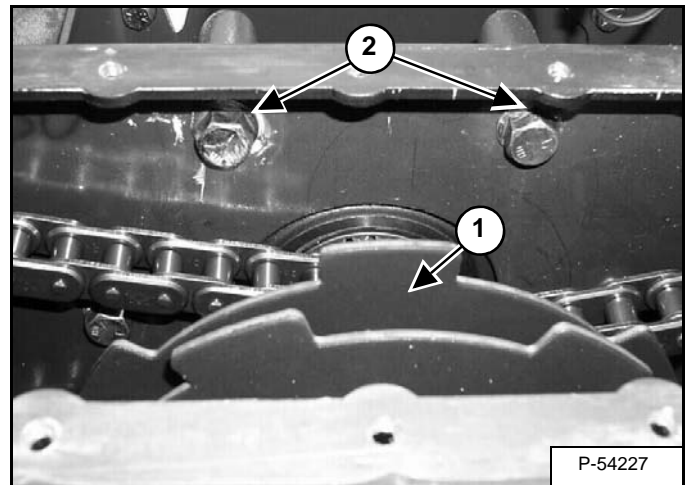

Remove the parking brake disc (Item 1) [Figure 40-20-20]. (See Disc Removal And Installation on Page 40-10-1.) or (See Disc Removal And Installation on Page 40-11-1.)

Remove the six carrier mounting bolts (Item 2) [Figure 40-20-20] from inside the chaincase.

Installation: Tighten the motor carrier mounting bolts to 170 - 190 N•m (125 - 140 ft-lb) torque.

Figure 40-20-21

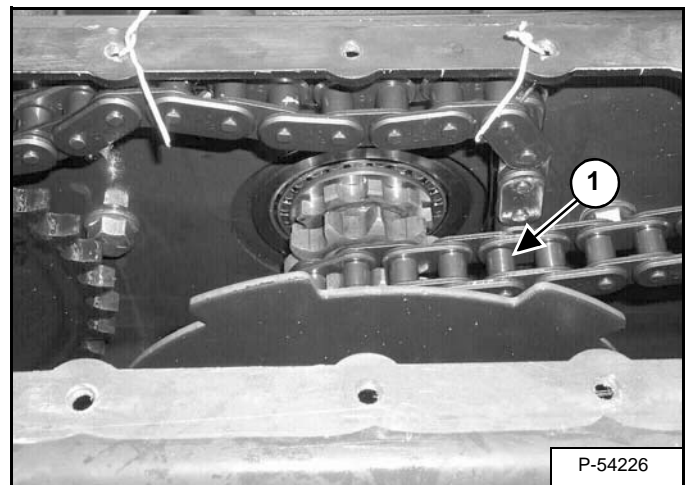

Tip the end of the sprocket on the motor carrier toward the rear of the loader and remove the rear drive chain from the sprocket.

NOTE: It may be necessary to tie the front drive chain up as shown in photo [Figure 40-20-21], so the carrier / motor assembly can be moved enough to free the rear drive chain (Item 1) [Figure 40-20-21] from the sprocket.

Remove the front drive chain from the chaincase.

SEAT BAR

Description

The seat bar is the secondary restraint system that has a sensor that automatically stops the loader functions until the seat bar is lowered.

The seat bar is located in the operator cab.

Removal And Installation

Figure 50-10-1

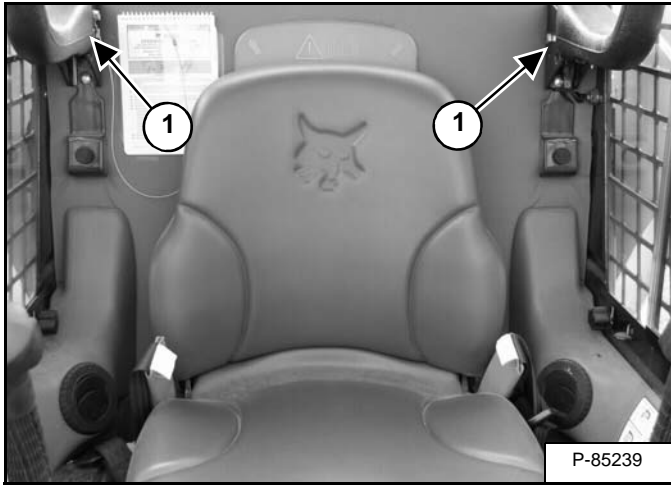

Raise the seat bar (Item 1) [Figure 50-10-1].

Figure 50-10-2

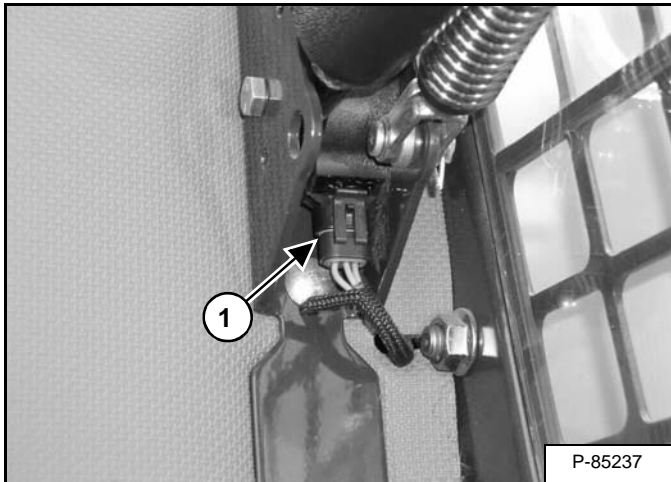

Disconnect the seat bar sensor (Item 1) [Figure 50-10-2] from the cab harness.

Lower the seat bar.

Raise the operator cab. (See Raising on Page 10-30-1.)

Figure 50-10-3

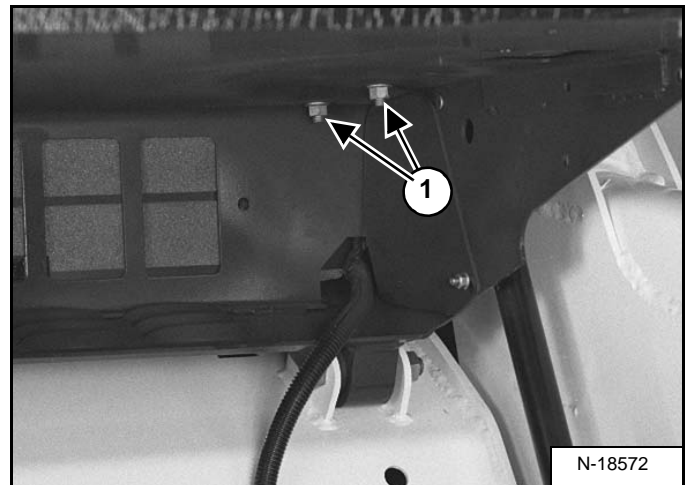

Remove the seat bar mounting nuts (Item 1) [Figure 50-10-3] (both sides).

Installation: Tighten the nuts to 33,9 - 38 N•m (25 - 28 ft-lb) torque.

Lower the operator cab. (See Lowering on Page 10-30-2.)

Figure 50-10-4



Remove the seat bar (Item 1) [Figure 50-10-4] from the operator cab.

Reverse the above procedure to install the seat bar into the operator cab.

OPERATOR SEAT

Removal And Installation

Figure 50-30-1

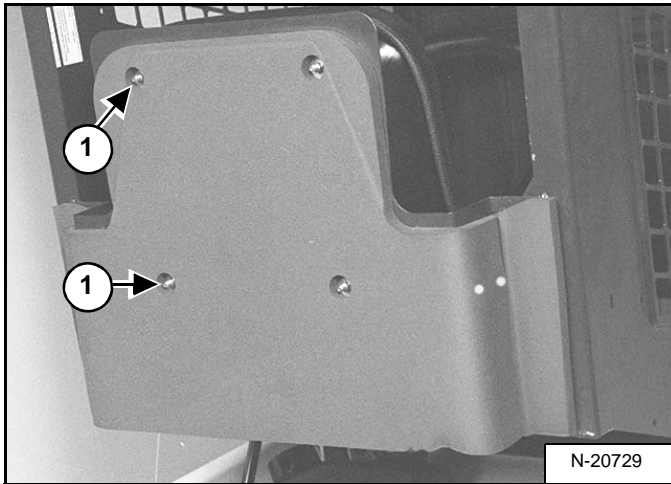

Raise the operator cab. (See Raising on Page 10-30-1.)

Remove the four seat mounting nuts (Item 1) [Figure 50-30-1] and washers from the operator seat mounting studs.

Installation: Tighten the mounting nuts to 27 N•m (20 ft-lb) torque.

NOTE: Ensure the washers are installed.

Figure 50-30-2

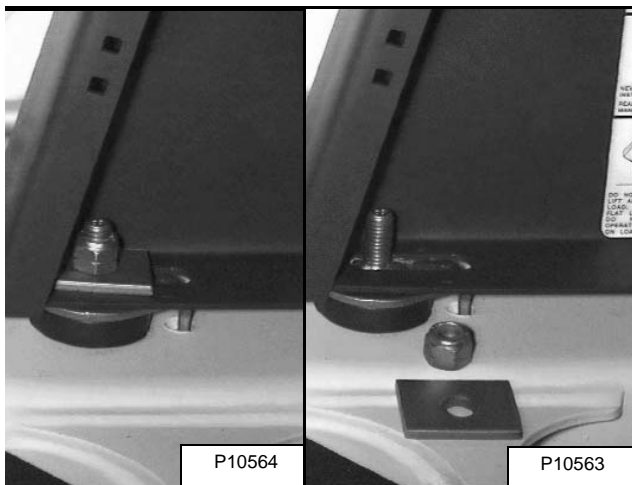

Lower the cab and install one of the mounting washers and a nut [Figure 50-30-2].

NOTE: With the seat removed the cab will raise.

Reverse the removal procedure to install the operator seat.

Seat Belt Removal And Installation

Figure 50-30-3

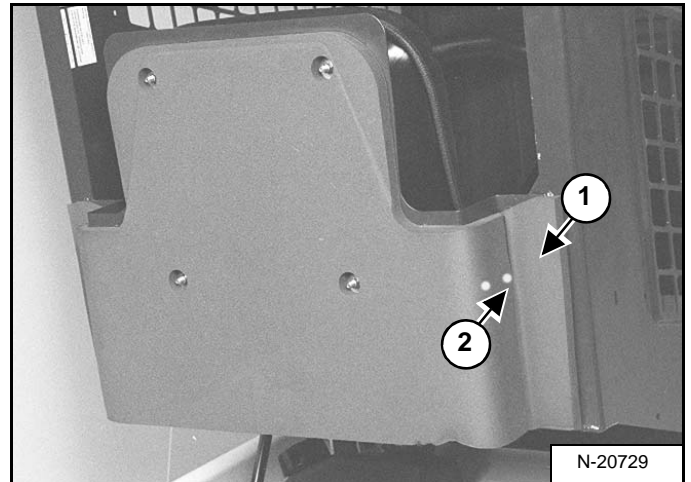

Raise the operator cab. (See Raising on Page 10-30-1.)

Locate the seat belt bolts under seat pan insulation (Item 1 and 2) [Figure 50-30-3] and peel back or cut insulation to gain access to the head.

Figure 50-30-4

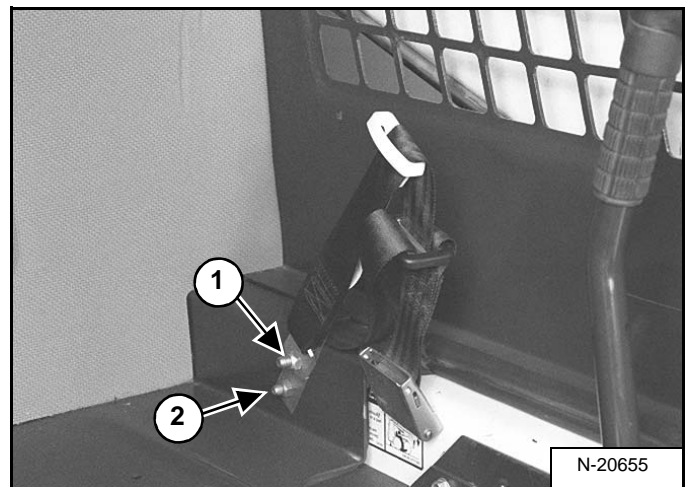

Remove the two nuts (Item 1 and 2) [Figure 50-30-4].

Installation: Tighten nut (Item 1) [Figure 50-30-4] to 73 N•m (54 ft-lb) torque. Tighten nut (Item 2) [Figure 50-30-4] to 46 N•m (34 ft-lb) torque.

Repeat for other half of seat belt and guide

BOB-TACH (HAND LEVER) (CONT'D)

Lever And Wedge Disassembly And Assembly (Cont'd)

Figure 50-40-8

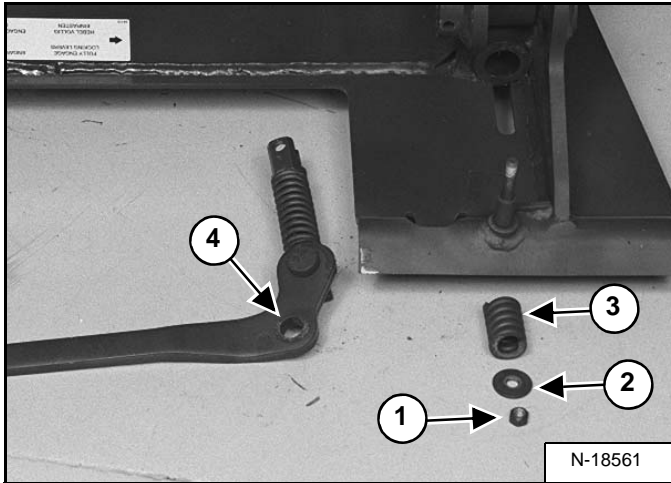

Remove the lever mounting nut (Item 1), washer (Item 2), spring (Item 3) and lever (Item 4) [Figure 50-40-8].

Installation: Tighten the nut to 34 - 38 N•m (25 - 28 ft-lb) torque.

Figure 50-40-9

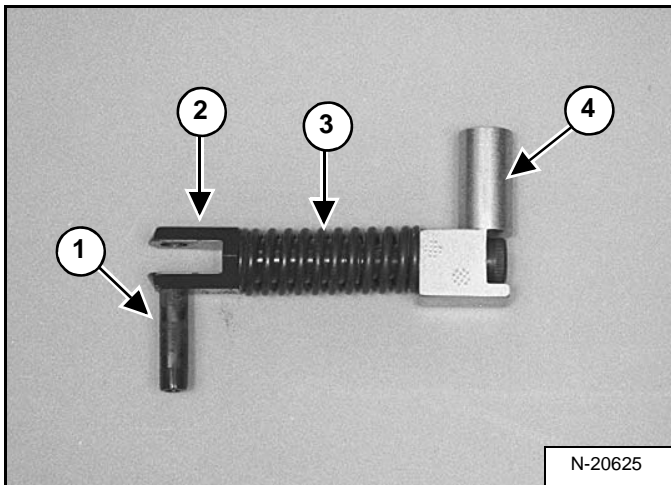

If the bolt (Item 1), handle pivot (Item 2), spring (Item 3), or clevis (Item 4) [Figure 50-40-9] are damaged, put the assembly in a vise.

Remove the bolt and replace the damaged parts as needed.

Figure 50-40-10

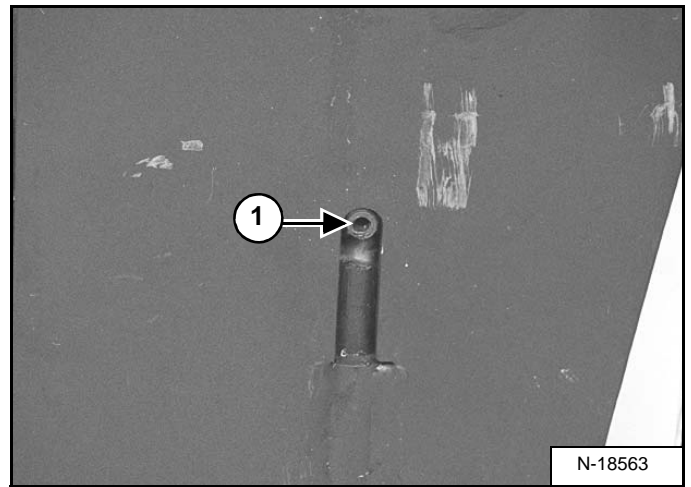

Use a punch and hammer to drive the roll pin (Item 1) [Figure 50-40-10] flush with the face of the Bob-Tach.

Reverse the removal procedure to install the Bob-Tach lever and wedge [Figure 50-40-10].

LIFT ARMS (CONT'D)

Removal And Installation (Cont'd)

Figure 50-50-16

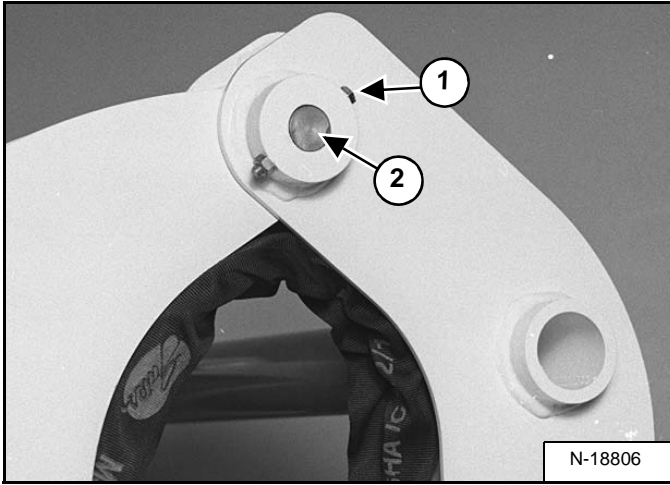

Remove the retainer bolt (Item 1) [Figure 50-50-16] and nut from the lift arm pin (both sides).

Use a drift pin and hammer remove the lift arm pivot pin (Item 2) [Figure 50-50-16] (both sides).

Figure 50-50-17

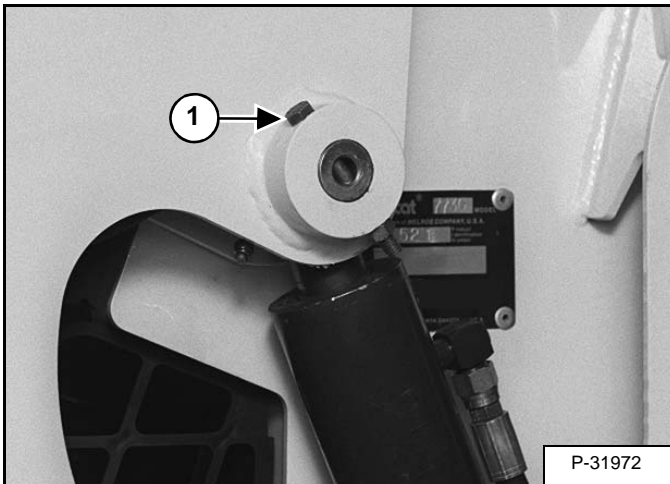

Remove the retainer bolt (Item 1) [Figure 50-50-17] and nut from the lift cylinder rod end pivot pin (both sides).

Figure 50-50-18

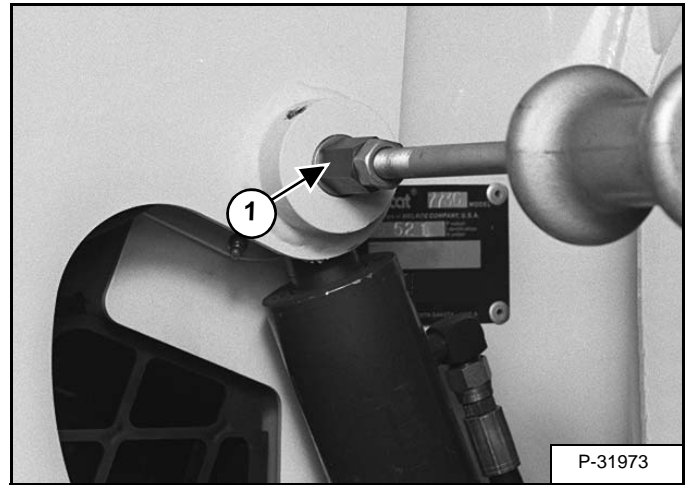

Use a slide hammer remove the lift cylinder rod end pivot pin (Item 1) [Figure 50-50-18] (both sides).

Strap the lift cylinders to rear of the uprights.

FUEL TANK (CONT'D)

Fuel Fill Screen Removal And Installation

Figure 50-80-7

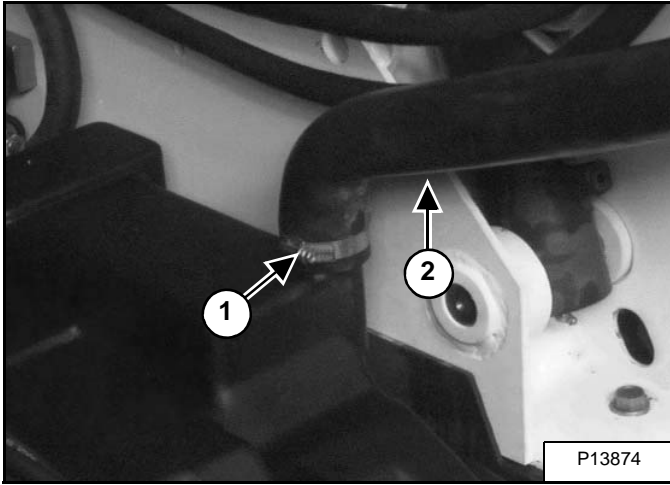

Remove the clamp (Item 1) [Figure 50-80-7] and remove the fuel fill hose (Item 2) [Figure 50-80-7] from the tank.

Figure 50-80-8

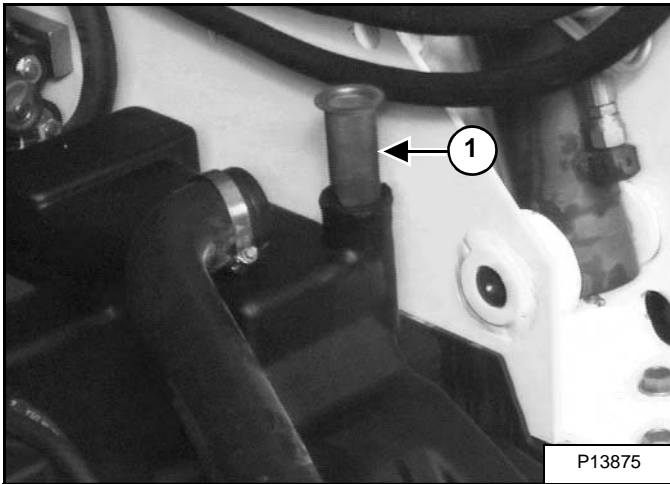

Remove the fuel fill screen (Item 1) [Figure 50-80-8] from the tank. Check the screen for damage and replace if necessary.

Remove the fuel supply screen (Item 1) [Figure 50-80-8] from the hose. Check the screen for damage and replace if necessary.

CONTROL PANEL

Description

Figure 50-100-1

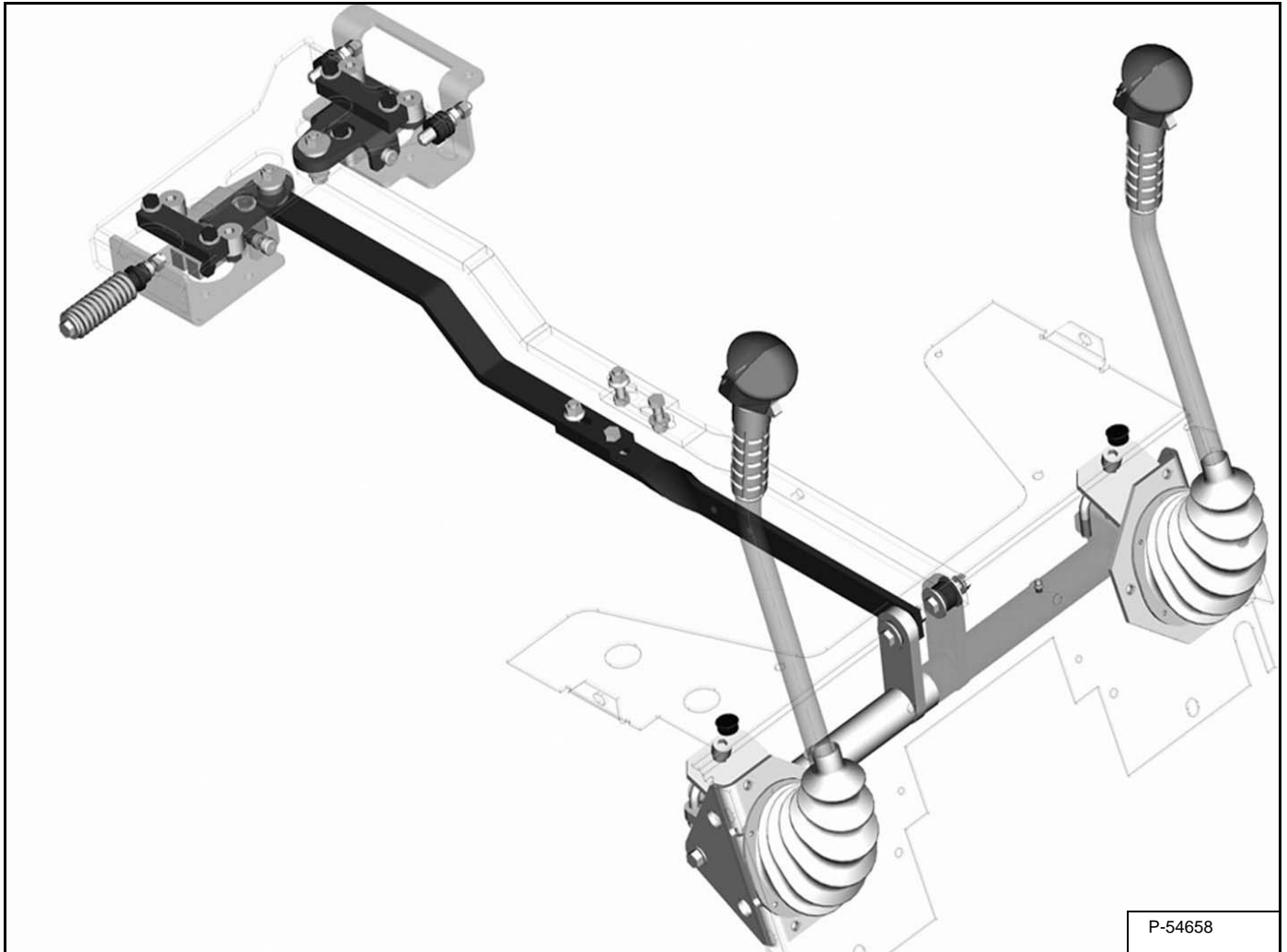

The steering system [Figure 50-100-1] consists of independent steering levers the operator uses to provide steering input to the loader.

The steering levers are attached to pivoting bellcranks that pivot on a steering shaft and plastic bushings. The bellcranks have grease fittings.

The forward travel is adjusted by drift adjustment bolts.

The bellcranks are attached to steering linkage bars with rubber torsion bushings pressed into the bellcranks. Bellcranks mount to the control panel.

Steering linkage bars are a two-piece design. Steering linkage bars are adjustable in length for "full travel adjustment".

Steering linkage bars attach to the pintle arms where a rubber torsion bushing is pressed into the pintle arms.

Pintle arms are of a two-piece design that allow easy adjustment of the neutral or "creep".

The steering system returns the levers to their starting position by means of the centering spring and the returning force of the torsion bushings.

NOTE: Torsion bushings need to be replaced if torn or rotating in the housing. Loosen torsion bushing bolts slightly before adjustments are made. Do not fully tighten torsion bushing bolts again until all steering adjustments have been made first.

Sequence of steering adjustments:

1. Set neutral of pintle arms, "creep"
2. Set full travel at steering linkage bars
3. Set drift at drift adjustment bolts

CONTROL PANEL (CONT'D)

Linkage Removal And Installation (Cont'd)

Figure 50-100-23

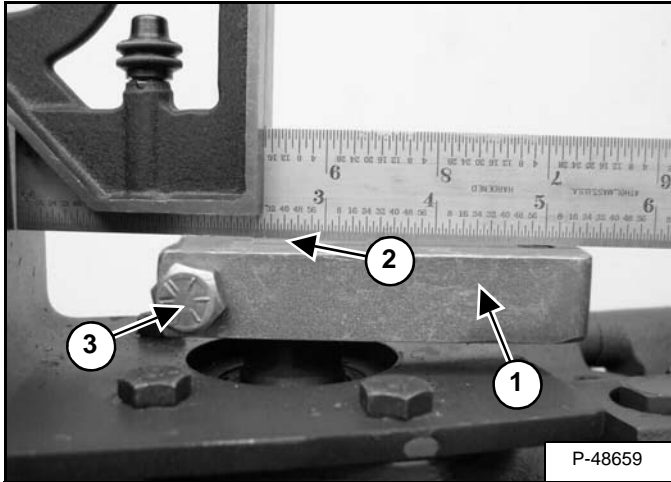

NOTE: When installing the pintle base (Item 1) onto the pump shaft (Item 2) [Figure 50-100-24] and inspect the pintle solid cams for damage or excessive wear.

Installation: Install the pintle base (Item 1) onto the pump shaft (Item 2) [Figure 50-100-23]. The top of the pintle base should be level with the top of the pump shaft. Tighten the bolt to 47,5 - 54,2 N•m (35 - 40 ft-lb) torque.

NOTE: After installing the linkage onto the hydrostatic pumps the linkage neutral adjustment procedure must be performed. (See Linkage Neutral (Adjusting) on Page 50-100-13.)

Pintle Arm Disassembly And Assembly

Figure 50-100-24

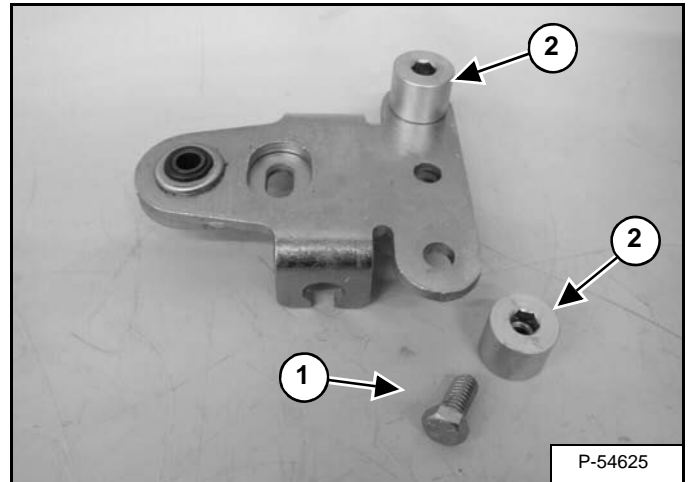

Remove the bolt (Item 1) from the pintle solid cams (Item 2) [Figure 50-100-24] and inspect the pintle solid cams for damage or excessive wear.

Installation: Tighten the bolts to 47,5 - 54,2 N•m (35 - 40 ft-lb) torque.

Figure 50-100-25

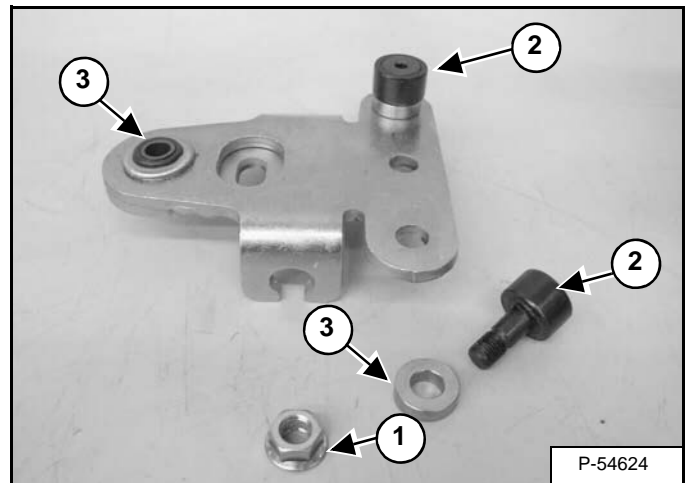

NOTE: The pintle roller cams (Item 2) [Figure 50-100-25] are used on ACS loaders only.

Remove the nut (Item 1) from the pintle roller cams (Item 2) and inspect the pintle roller cams and washers (Item 3) for damage [Figure 50-100-25].

Inspect the torsion bushing (Item 3) [Figure 50-100-25] for damage and replace as needed.

Installation: Tighten the nuts to 47,5 - 54,2 N•m (35 - 40 ft-lb) torque.

CONTROL PANEL (SJC)

Description

The SJC control panel has two electronic handles that control the steering, lift, and tilt functions. There is no mechanical linkages connecting to the hydrostatic pumps or the control valve.

The control panel is connected to the lower mainframe and wraps around and underneath the operator seat.

Removal And Installation

! WARNING

Put jackstands under the front axles and rear corners of the frame before running the engine for service. Failure to use jackstands can allow the machine to fall or move and cause injury or death.

W-2017-0286

! DANGER

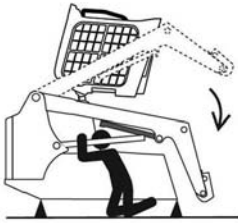

P-90328

AVOID DEATH

- Disconnecting or loosening any hydraulic tubeline, hose, fitting, component or a part failure can cause lift arms to drop.
- Keep out of this area when lift arms are raised unless supported by an approved lift arm support. Replace if damaged.

D-1009-0409

! WARNING

Never work on a machine with the lift arms up unless the lift arms are secured by an approved lift arm support device. Failure to use an approved lift arm support device can allow the lift arms or attachment to fall and cause injury or death.

W-2059-0598

Raise the lift arms and install an approved lift arm support device. (See Installing on Page 10-20-1.)

Raise the operator cab. (See Raising on Page 10-30-1.)

Remove the engine speed control. (See Removal And Installation on Page 70-20-1.)

Figure 50-101-1

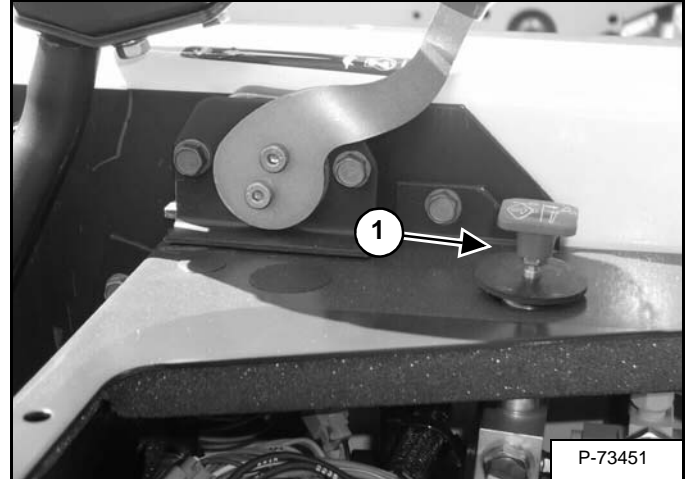

Remove the lift arm bypass control knob and rubber washer (Item 1) [Figure 50-101-1].

Figure 50-101-2

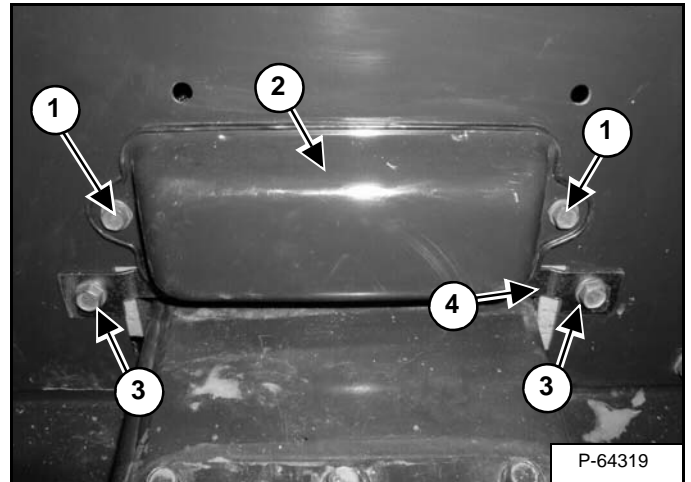

Remove the fuse cover mount screws (Item 1) [Figure 50-101-2].

Installation: Tighten screws to 11 - 15 N•m (8 - 11 ft-lb) torque.

Remove the fuse / relay cover (Item 2) [Figure 50-101-2].

Remove the fuse / relay shield mounting screws (Item 3) [Figure 50-101-2].

Installation: Tighten screws to 20 - 27 N•m (15 - 20 ft-lb) torque.

Remove the fuse / relay shield (Item 4) [Figure 50-101-2]

CONTROL HANDLE / LEVER (ACS) (CONT'D)

Boot Removal And Installation

Figure 50-111-22

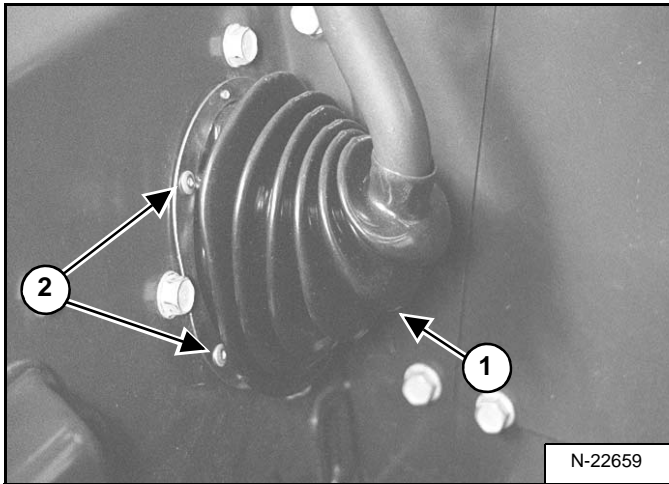

To replace the rubber boot (Item 1) **[Figure 50-111-22]** on the control panel, remove the control lever. (See Boot Removal And Installation on Page 50-110-2.)

Drill out the four rivets (Item 2) **[Figure 50-111-22]** located on the flange of the rubber boot and remove the old boot.

Install the new boot and reinstall the control lever. (See Boot Removal And Installation on Page 50-110-2.)

ACCESS PANEL (INSIDE) (SJC) (CONT'D)

Removal And Installation (Right) (Cont'd)

Figure 50-121-6

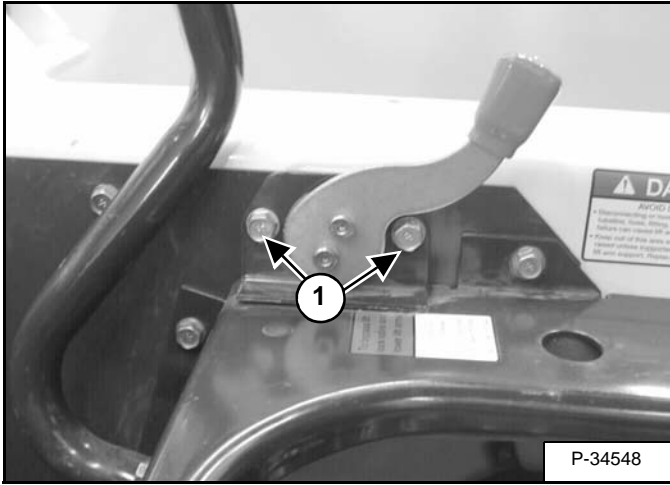

Remove the two mount screws (Item 1) [Figure 50-121-6] from the hand operated speed control lever.

Installation: Tighten the screws to 20 - 27 N•m (15 - 20 ft-lb) torque.

Figure 50-121-7

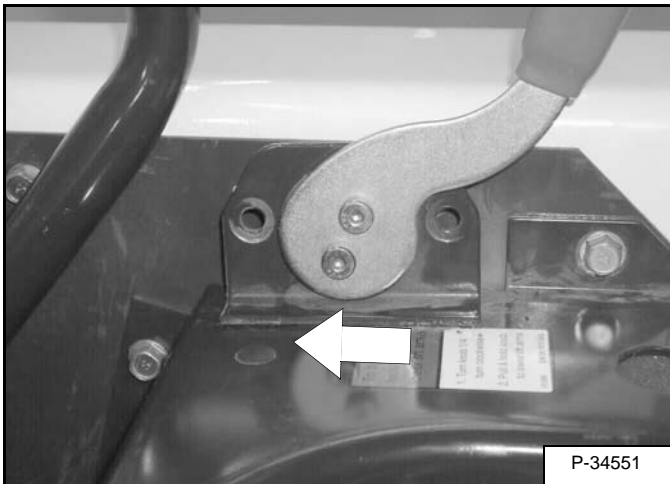

Lift slightly on the speed control handle and move it toward the front of the loader [Figure 50-121-7].

Figure 50-121-8

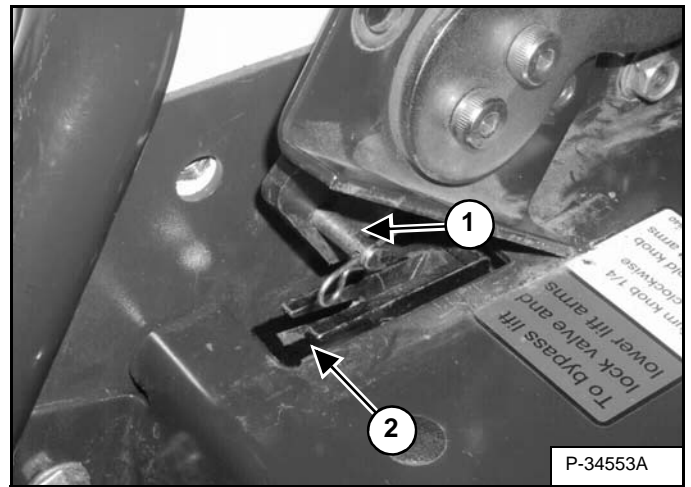

Lift the speed control pin (Item 1) from the notch (Item 2) in the speed control rod [Figure 50-121-8].

Figure 50-121-9

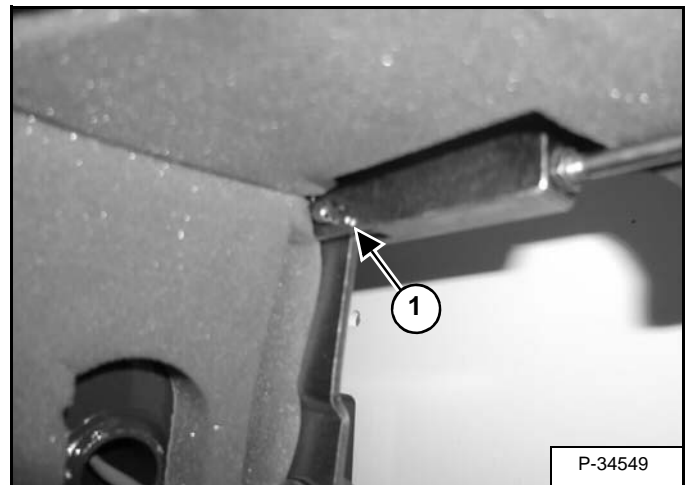

At the bottom right side of the control panel, remove the keeper and pin (Item 1) [Figure 50-121-9] that connects the speed control linkage arm to the speed control rod.

WINDOW (CAB DOOR)

Removal (Standard Window)

Figure 50-133-1

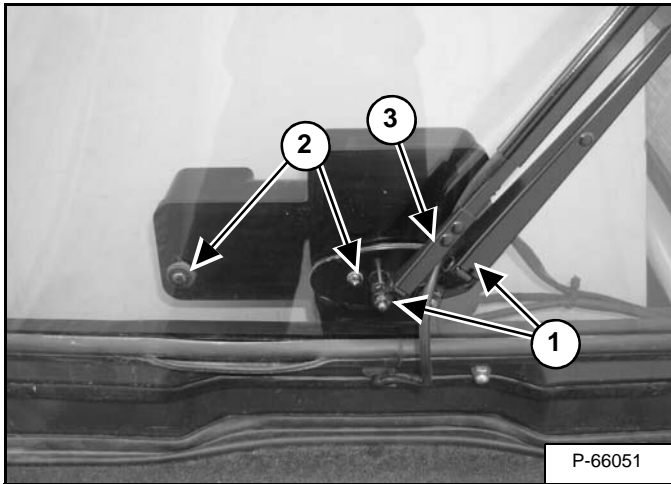

Remove the wiper arm assembly (Item 1) [Figure 50-133-1].

Remove the two screws (Item 2) and the nut (Item 3) [Figure 50-133-1].

Secure the wiper motor inside the cab.

Figure 50-133-2

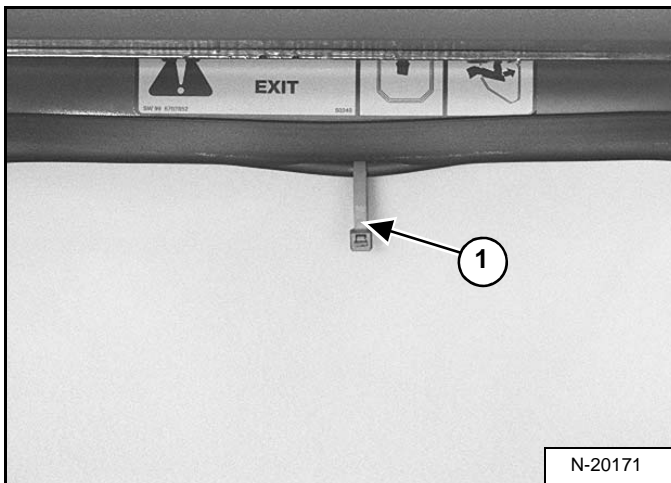

Pull the plastic loop (Item 1) [Figure 50-133-2] at the top of the window to remove the rubber cord.

Figure 50-133-3

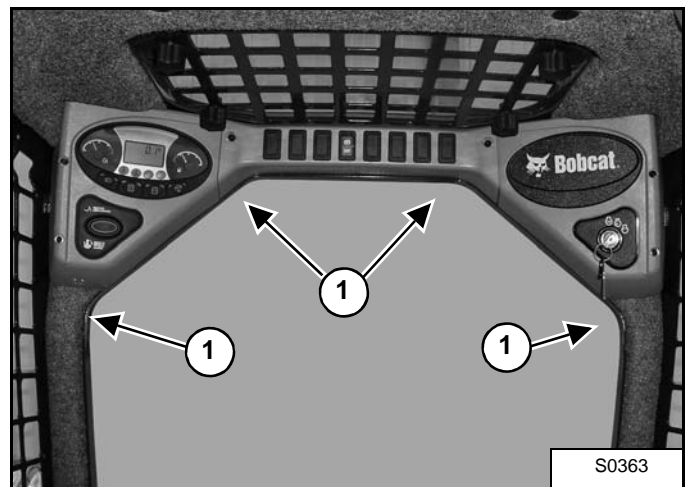

Push the window out at any corner of the window (Item 1) [Figure 50-133-3].

NOTE: The window may fall when pushing on the corners. Have a second technician assist you during the removal of the window.

CONTROL SYSTEM (ACS)	60-130-1
Description	60-130-1
Troubleshooting	60-130-2
Handle Sensor Connector Disassembly And Assembly	60-130-3
Switch Handle Removal	60-130-4
Switch Handle Installation	60-130-6
Actuator Connector Disassembly And Assembly	60-130-9
Handle Lock Solenoid Removal And Installation	60-130-10
Handle Lock Solenoid Disassembly And Assembly	60-130-10
Foot Sensor Disassembly And Assembly	60-130-11
Foot Lock Solenoid Removal And Installation	60-130-12
ELECTRICAL / HYDRAULIC CONTROLS	60-140-1
Identification Chart	60-140-1
Description	60-140-2
Identification Chart ACD Group 0	60-140-3
Identification Chart ACD Group 1	60-140-4
Identification Chart ACD Group 2	60-140-5
Identification Chart ACD Group 3	60-140-6
ELECTRICAL / HYDRAULIC CONTROLS (ACS)	60-141-1
Identification Chart	60-141-1
Description	60-141-2
Identification Chart ACD Group 0	60-141-3
Identification Chart ACD Group 1	60-141-4
Identification Chart ACD Group 2	60-141-5
Identification Chart ACD Group 3	60-141-6
ELECTRICAL / HYDRAULIC CONTROLS (SJC)	60-142-1
Identification Chart	60-142-1
Description	60-142-2
Identification Chart ACD Group 0	60-142-3
Identification Chart ACD Group 1	60-142-4
Identification Chart ACD Group 2	60-142-5
Identification Chart ACD Group 3	60-142-6
SERVICE PC (LAPTOP COMPUTER)	60-150-1
Connecting Remote Start Tool	60-150-1
Connecting Remote Start Tool (Service Tool)	60-150-1
CALIBRATION	60-160-1
Description	60-160-1
Actuator Testing	60-160-1
Lift And Tilt Calibration (SJC)	60-160-4
Hydrostatic Pump Calibration (SJC)	60-160-6
Lift And Tilt Calibration (ACS)	60-160-11
STEERING DRIFT COMPENSATION	60-161-1
Description	60-161-1
Operation	60-161-1

ELECTRICAL SYSTEM INFORMATION (CONT'D)

Glossary Of Electrical Symbols (Cont'd)

SYMBOL

DESCRIPTION

SENDERS AND SENSORS

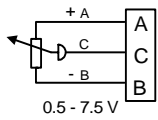

PRESSURE SENDER - Provides a variable voltage proportional to pressure. (Sender voltage rating is listed to show volts at high and low setting.)

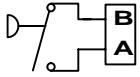

PRESSURE SWITCH - Switch opens or closes at a predetermined pressure to active a function or to turn on a warning light. (Switch is shown in the open position.)

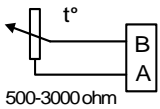

TEMPERATURE SENDER - Provides a variable resistance (ohm) signal proportional to temperature. (Sender ohm rating is listed to show ohms at high and low setting.)

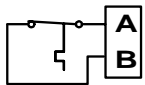

TEMPERATURE SWITCH - The switch opens or closes at a predetermined temperature to active a function or to turn on a warning light. (Switch is shown in the closed position.)

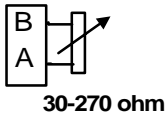

FUEL SENDER - Provides a variable resistance, based on the fuel level in the tank. (Sender ohm rating is listed to show ohms at full and empty setting.)

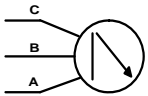

HALL EFFECT SENSOR - Detects linear or rotary position and provides a proportional variable voltage.

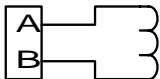

SPEED SENSOR - magnetic pickup - detects rpm.

BATTERY (CONT'D)

Using A Booster Battery (Jump Starting)

If it is necessary to use a booster battery to start the engine, BE CAREFUL! There must be one person in the operator's seat and one person to connect and disconnect the battery cables.

The key switch must be OFF or the STOP button must be pressed. The booster battery must be 12 volt.

WARNING

**BATTERY GAS CAN EXPLODE AND CAUSE
SERIOUS INJURY OR DEATH**

Keep arcs, sparks, flames and lighted tobacco away from batteries. When *jumping* from booster battery make final connection (negative) at machine frame.

Do not jump start or charge a frozen or damaged battery. Warm battery to 16°C (60°F) before connecting to a charger. Unplug charger before connecting or disconnecting cables to battery. Never lean over battery while boosting, testing or charging.

W-2066-0910

Figure 60-20-4

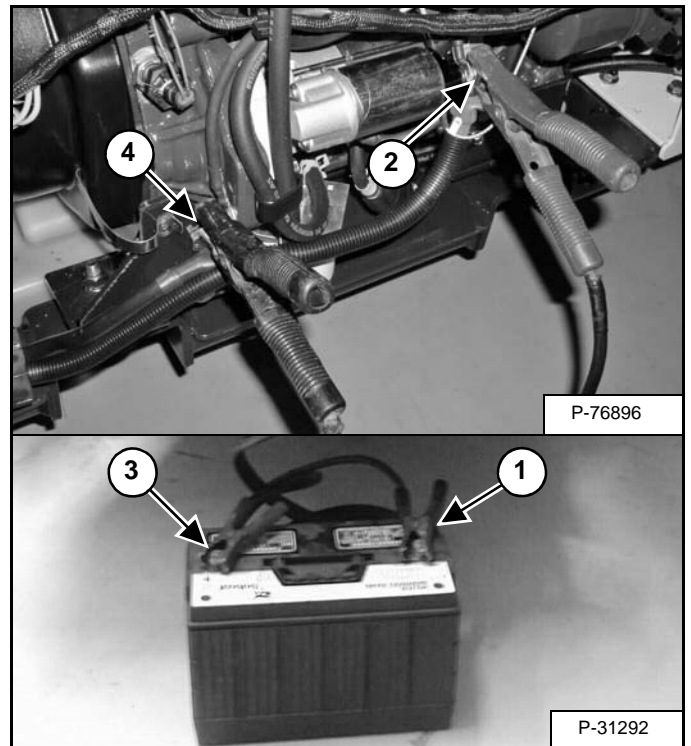

Connect the end of the first cable (Item 1) [Figure 60-20-4] to the positive (+) terminal of the booster battery. Connect the other end of the same cable (Item 2) [Figure 60-20-4] to the positive terminal on the loader starter.

Connect the end of the second cable (Item 3) [Figure 60-20-4] to the negative terminal of the booster battery. Connect the other end of the same cable (Item 4) [Figure 60-20-4] to the engine.

Keep cables away from moving parts. Start the engine.

After the engine has started, remove the ground (-) cable (Item 4) [Figure 60-20-4] first. Remove the cable from the positive terminal (Item 2) [Figure 60-20-4].

IMPORTANT

Damage to the alternator can occur if:

- Engine is operated with battery cables disconnected.
- Battery cables are connected when using a fast charger or when welding on the loader. (Remove both cables from the battery.)
- Extra battery cables (booster cables) are connected wrong.

I-2023-1285

INSTRUMENT PANELS (CONT'D)

Key Switch Removal And Installation

Remove the right side instrument panel. (See Removal And Installation (Left And Right) on Page 60-50-7.)

Figure 60-50-17

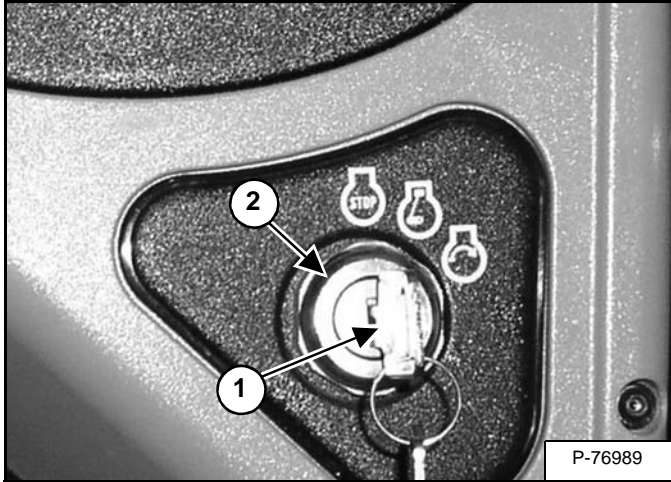

Remove the ignition key (Item 1) from the switch. Remove the ignition switch retaining nut (Item 2) [Figure 60-50-17] from the switch.

Remove the ignition switch from the control panel.

Alarm Removal And Installation

Figure 60-50-18

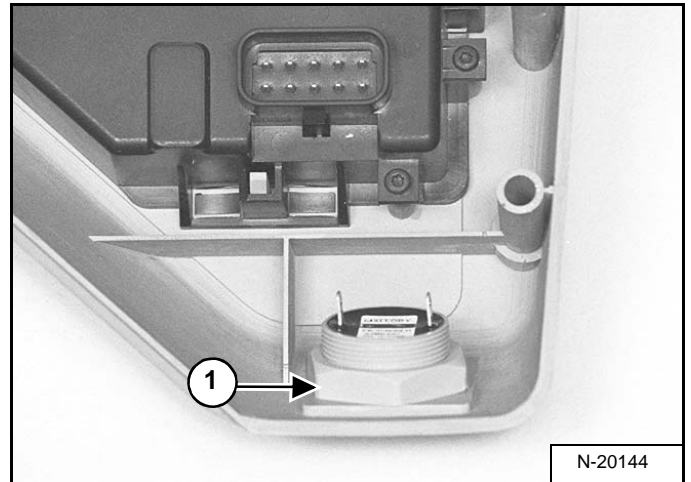

Remove the left side instrument panel.

Remove the retaining nut (Item 1) [Figure 60-50-18] from the loader alarm.

Remove the alarm from the loader instrument panel.

Figure 60-50-19

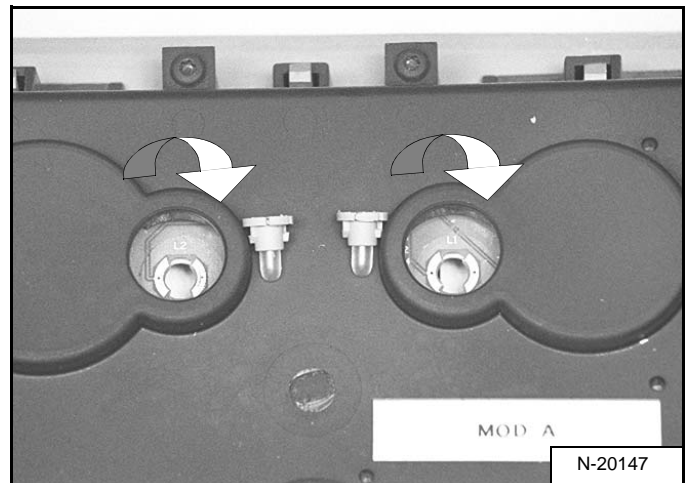

To install the bulbs, place them in the sockets and turn clockwise [Figure 60-50-19].

BOBCAT CONTROLLER (GATEWAY AND AUXILIARY) (CONT'D)

Connector Identification (Cont'd)

J2B

PIN	WIRE NUMBER	COLOR	DESCRIPTION
1	OPEN	NA	NA
2	1180	RED/WHT	COMPUTER FUSE POWER OUT
3	1150	RED/WHT	COMPUTER FUSE POWER OUT
4	4450	LGN	DIVERTER SOLENOID SIGNAL
5	4440	LGN	REAR BASE SIGNAL
6	4480	LGN	FRONT / REAR AUXILIARY SIGNAL
7	4430	LGN	REAR ROD SIGNAL
8	9220	PURPLE	CAN LO 0
9	9120	PUR/WHT	CAN HI 0
10	OPEN	NA	NA
11	OPEN	NA	NA
12	OPEN	NA	NA
13	4340	LGN	FRONT BASE SOLENOID SIGNAL
14	OPEN	NA	NA
15	2550	BLACK	AUXILIARY CONTROLLER GROUND
16	2540	BLACK	AUXILIARY CONTROLLER GROUND
17	4310	LBL	RIGHT HANDLE PWM LOW
18	4320	LBL	RIGHT HANDLE PWM SIGNAL
19	4330	LGN	FRONT ROD SOLENOID SIGNAL
20	OPEN	NA	NA
21	4920	LGN	RIGHT HANDLE TRIGGER RETURN
22	1560	RNG	SWITCHED INPUT POWER
23	4300	LGN	RIGHT HANDLE PWM HIGH
24	OPEN	NA	NA
25	OPEN	NA	NA
26	4460	LGN	HIGH FLOW SOLENOID SIGNAL

BOBCAT CONTROLLER (SJC) (DRIVE) (CONT'D)

Connector Identification (Cont'd)

SAFETY IN 1 9420	OPEN 2	OPEN 3	H-PATTERN SWITCH 4 4550	OPEN 5		ISO LIGHT 6 4220	LEFT SWASH ANGLE 7 4950	RIGHT SWASH ANGLE 8 4720	OPEN 9	OPEN 10
LEFT FORWARD RETURN 11 2670	CAN HIGH 12 9530	LEFT FRONT ANGLE 13 3040	RIGHT FRONT ANGLE 14 3140	LEFT REAR ANGLE 15 3030		H-PATTERN LIGHT 16 4275	R REAR ANGLE 17 3130	LEFT JOYSTICK X-AXIS 18 4530	LEFT JOYSTICK Y-AXIS 19 4540	OPEN 20
LEFT FWD DRIVE 21 4270	CAN LOW 22 9630	RIGHT WHEEL SPEED A 23 3000	RIGHT WHEEL SPEED B 24 3070	TWO SPEED 25 4350		BRAKE LIGHT 26 4210	GROUND 27 2470	GROUND 28 2490	SENSOR GROUND 29 2510	5V SUPPLY WHEEL ANGLE 30 1590
LEFT REVERSE DRIVE 31 4280	CAN SHIELD 32 9730	LEFT WHEEL SPEED A 33 3020	LEFT WHEEL SPEED B 34 3080	SAFETY OUT 35 9410		BACKUP ALARM 36 7100	OPEN 37	OPEN 38	OPEN 39	5V SUPPLY WHL SPD - JOYSTICK 40 1640
LEFT REVERSE RETURN 41 2680	RIGHT FORWARD RETURN 42 2660	RIGHT FORWARD DRIVE 43 4260	RIGHT REVERSE DRIVE 44 4250	RIGHT REVERSE RETURN 45 2650		TWO SPEED 2 46 4390	UNSWITCH BATT #1 47 1250	UNSWITCH BATT #2 48 1260	OPEN 49	SWITCHED POWER 50 1750

DIAGNOSTIC SERVICE CODES (CONT'D)

Service Codes List (Cont'd)

CODE	DESCRIPTION	CODE	DESCRIPTION
M1502	Traction lock pull output error ON	M3805	Auxiliary hydraulic lock short to battery
M1503	Traction lock pull output error OFF	M3806	Auxiliary hydraulic lock short to ground
M1507	Traction lock pull output open circuit	M3807	Auxiliary hydraulic lock open circuit
M1528	Traction lock pull output failure	M3832	Auxiliary hydraulic lock overcurrent
M1605	Traction lock hold solenoid short to battery	M4109	Alternator low
M1606	Traction lock hold solenoid short to ground	M4110	Alternator high
M1607	Traction lock hold solenoid open circuit	M4304	Keyless panel no communication
M1705	Hydraulic lock valve solenoid short to battery	M4404	Auxiliary no communication
M1706	Hydraulic lock valve solenoid short to ground	M4621	5 volt sensor supply out of range high
M1707	Hydraulic lock valve solenoid open circuit	M4622	5 volt sensor supply out of range low
M1732	Hydraulic lock valve solenoid overcurrent	M4721	8 volt sensor supply out of range high
M1805	Lift spool lock short to battery	M4722	8 volt sensor supply out of range low
M1806	Lift spool lock short to ground	M4802	Front light relay error ON
M1807	Lift spool lock open circuit	M4803	Front light relay error OFF
M1832	Lift spool lock overcurrent	M4807	Front light relay open circuit
M2005	Two-speed primary short to battery	M4902	Rear light relay error ON
M2006	Two-speed primary short to ground	M4903	Rear light relay error OFF
M2007	Two-speed primary open circuit	M4907	Rear light relay open circuit
M2032	Two-speed primary overcurrent	M5002	Front light output error ON
M2102	Glow plug output error ON	M5003	Front light output error OFF
M2103	Glow plug output error OFF	M5007	Front light output open circuit
M2107	Glow plug output open circuit	M5028	Front light output failure
M2128	Glow plug output failure	M5102	Rear light output error ON
M2202	Starter output error ON	M5103	Rear light output error OFF
M2203	Starter output error OFF	M5107	Rear light output open circuit
M2207	Starter output open circuit	M5128	Rear light output failure
M2228	Starter output failure	M5202	PTOL switch error ON
M2302	Starter relay error ON	M5221	PTOL switch out of range high
M2303	Starter relay error OFF	M5222	PTOL switch out of range low
M2402	Fuel pull relay error ON	M5305	PTOL LED short to battery
M2403	Fuel pull relay error OFF	M5306	PTOL LED short to ground
M2502	Traction pull relay error ON	M5405	Tilt spool lock short to battery
M2503	Traction pull relay error OFF	M5406	Tilt spool lock short to ground
M2602	Glow plug relay error ON	M5407	Tilt spool lock open circuit
M2603	Glow plug relay error OFF	M5432	Tilt spool lock overcurrent
M2721	Throttle primary out of range high	M6402	Switched power relay error ON
M2722	Throttle primary out of range low	M6403	Switched power relay error OFF
M2821	Throttle secondary out of range high	M6505	EEC power short to battery
M2822	Throttle secondary out of range low	M6506	EEC power short to ground
M3128	Interrupted power failure	M6507	EEC power open circuit
M3204	Workgroup no communication	M6604	EEC power no communications
M3304	Deluxe panel no communication	M7002	Switched power output error ON
M3505	Hydraulic fan short to battery	M7003	Switched power output error OFF
M3506	Hydraulic fan short to ground	M7007	Switched power output open circuit
M3507	Hydraulic fan open circuit	M7028	Switched power output failure
M3532	Hydraulic fan overcurrent	M7102	Electric fan 1 output error ON
M3705	Two-speed secondary short to battery	M7103	Electric fan 1 output error OFF
M3706	Two-speed secondary short to ground	M7128	Electric fan 1 output failure
M3707	Two-speed secondary open circuit	M7202	Electric fan 1 relay error ON
M3732	Two-speed secondary overcurrent	M7203	Electric fan 1 relay error OFF

SEAT BAR SENSOR (CONT'D)

Removal And Installation (Cont'd)

Figure 60-110-12

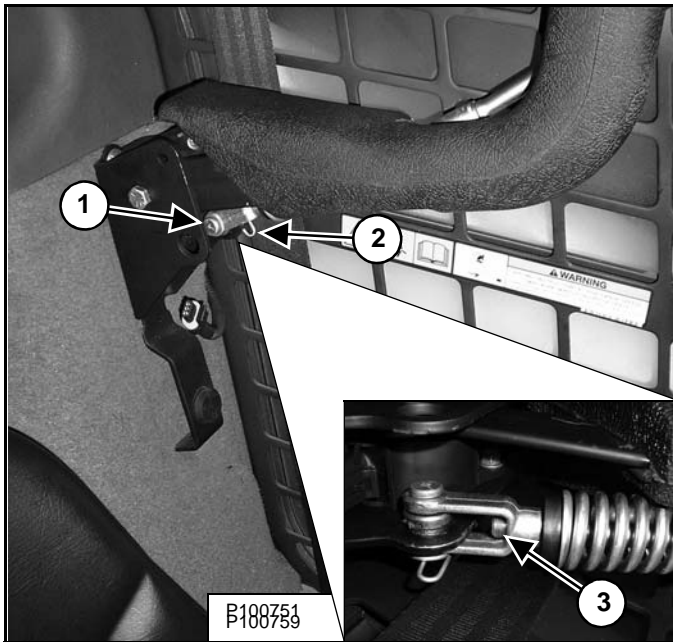

Reinstall the clevis pin (Item 1), and retaining pin (Item 2) **[Figure 60-110-12]**.

Loosen the clevis bolt (Item 3) until the end of the bolt is flush with the clevis, then tighten the clevis bolt three full turns to set proper tension of the compression spring.

Reconnect the sensor wiring connector (Item 2) **[Figure 60-110-5]**.

Reinstall the sensor mounting bolt and nut (Item 1) **[Figure 60-110-5]** and tighten to 6,8 N•m (60 in-lb) torque.

IMPORTANT

Be careful to not overtighten the sensor mounting bolt and nut to prevent breakage of the sensor.

I-2088-1095

Verify correct seat bar sensor function by performing all of the steps in the Bobcat Interlock Control System (BICS™) inspection as described in the loader Operation & Maintenance Manual.

CONTROL SYSTEM (ACS)

Description

The (ACS) Actuator Control System system is an option that allows the operator to quickly switch between foot and hand control modes.

The ACS control uses the electric actuators on the main hydraulic control valve to control the lift and tilt spools in the hydraulic control valve, foot sensors, handle sensors and a specially designed control handle.

Hand controls contain a locking solenoid which lock when the switch on the center control panel is switched to foot mode.

Foot controls also contain solenoids which lock when the switch on the center control panel is switched to hand mode.

Both the hand and foot controls contain sensors that relay information to the ACS controller as to which function should be activated and how far the spool should be moved.

CONTROL SYSTEM (ACS) (CONT'D)

Foot Sensor Disassembly And Assembly

Figure 60-130-28

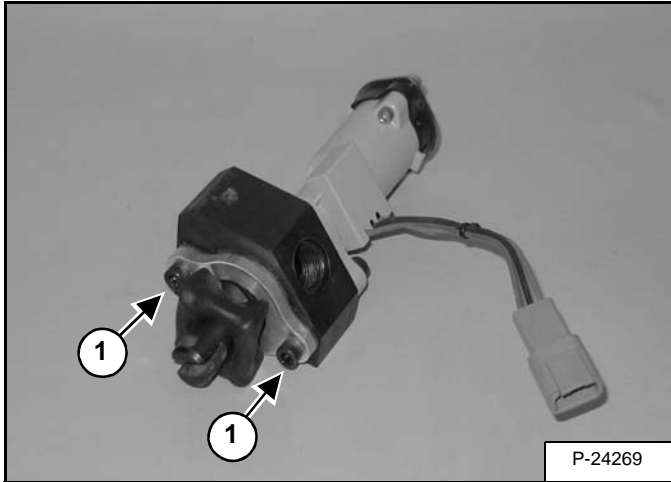

Remove the two bolts (Item 1) [Figure 60-130-28] from the end of the foot sensor.

Installation: Tighten the bolts to 10,2 N•m (90 in-lb) torque. Apply Loctite® 242 to the threads.

Figure 60-130-29

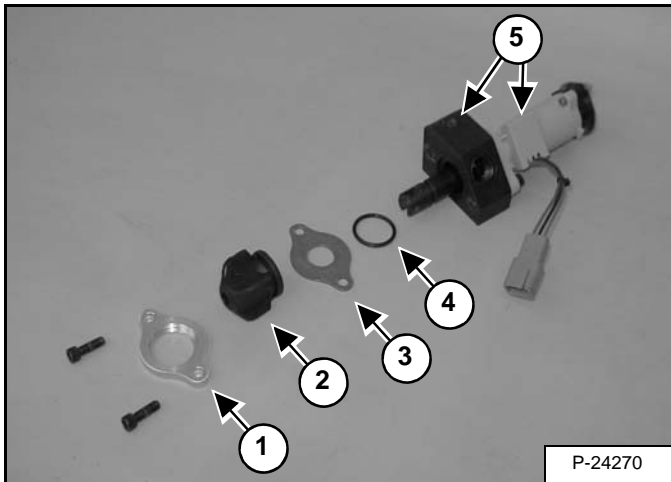

Remove the boot retainer (Item 1), boot (Item 2), spool stop plate (Item 3), O-ring (Item 4) [Figure 60-130-29].

NOTE: Do not disassemble the sensor assembly (Item 5) [Figure 60-130-29]. The sensor assembly is a calibrated assembly and cannot be serviced. Order through Bobcat Parts.

ELECTRICAL / HYDRAULIC CONTROLS (ACS) (CONT'D)

Identification Chart ACD Group 0

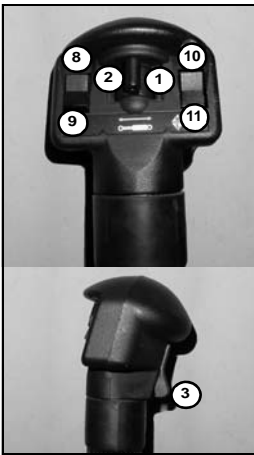
Left side Control Handle Switches	Switch Number	Solenoid Number Activated				Attachment Harness Terminal Activated	Attachment Harness Connector	Right Side Control Handle Switches
		STD	RH	HFH	RH / HFH			
	1	1	1	1, 7	1, 7	K		
	2	2	2	2	2	K		
	3	1	1	1, 7	1, 7	K		
	4	2	3,5,6	2	3,5,6	K,A,D		
	5	1	4,5,6	1	4,5,6	K,A,C		
	6	1	4,5,6	1	4,5,6	K,E		
	7	1	4,5,6	1	4,5,6	K,F		
	8	1	4,5,6	1	4,5,6	K,G		
	9	1	4,5,6	1	4,5,6	K,H		
	10, 11, 12, 13, 14	-	--	--		K		

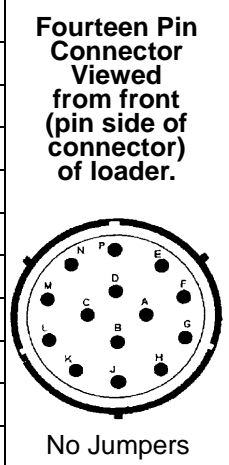

RH - Loaders with Rear Hydraulics Option.
HFH - Loaders with High Flow Hydraulics Option.
RH / HFH - Loaders with Rear Hydraulics and High Flow Hydraulics Option.
Terminal K is activated with Key switch ON.

NOTE: For diagnostics and troubleshooting connect the Service PC (See SERVICE PC (LAPTOP COMPUTER) on Page 60-150-1.)

The ACD (Attachment Control Device) automatically recognizes the use of the seven or fourteen pin connector when connected.

Pressing the auxiliary hydraulics button and moving the rear auxiliary hydraulic switch to the right and left several times activates solenoid numbers 3,4,5, and 6 at the diverter valve.

Front Auxiliary Pressure Release is accomplished by manually pushing the male and female couplers in at the front auxiliary block.

The High Flow Button in the left side instrument panel must be pushed ON to activate solenoid number seven at the gear pump.

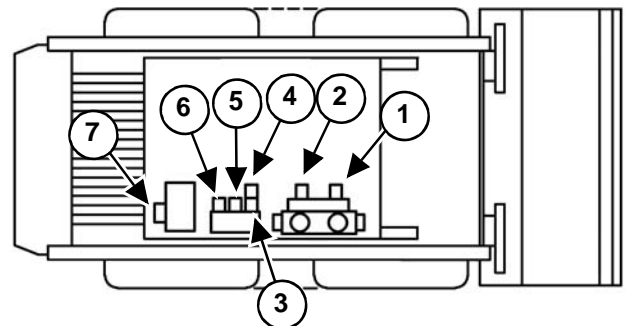

NA1891

Solenoid Number	Hydraulic Coupler	Wiring Number
1	Front Male (Rod)	4330
2	Front Female (Base)	4340
3	Diverter Rear (Rod)	4430
4	Diverter Rear (Base)	4440
5	Bleed / Lock Valve (Base)	4480
6	Bleed / Lock Valve (Rod)	4450
7	High Flow on Pump	4460

SERVICE PC (LAPTOP COMPUTER)

Connecting Remote Start Tool

Figure 60-150-1

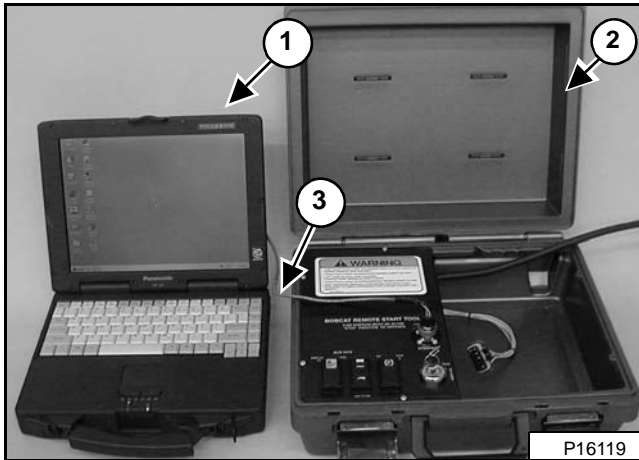

The tools listed will be needed to do the following procedure:

MEL1563 or 7003031 - Remote Start Tool
MEL1565 - Service Tool Harness Control
MEL1566 - Service Tool Harness Communicator (Computer Interface)

NOTE: Make all connections with the key in the OFF position.

The Service PC (Item 1) with the Remote Start Tool (Item 2) [Figure 60-150-1]. When connected to the loader, the Service PC is used to monitor, conduct diagnostics, and upgrade software.

Connect the Service Tool Harness Communicator (MEL1566) (Item 3) [Figure 60-150-1] to the designated serial port on the Service PC.

NOTE: The recommended serial cable length should not exceed 4,6 m (15 ft). A serial cable longer than 4,6 m (15 ft) will create a degraded signal causing communication errors.

Connect the other end to the connector on the Remote Start Tool.

Connect the Remote Start Tool to the loader. (See REMOTE START TOOL KIT-MEL1563 on Page 10-60-1.)

NOTE: Refer to BobcatNET for PC requirements and the latest Service Analyzer software.

Connecting Remote Start Tool (Service Tool)

Figure 60-150-2

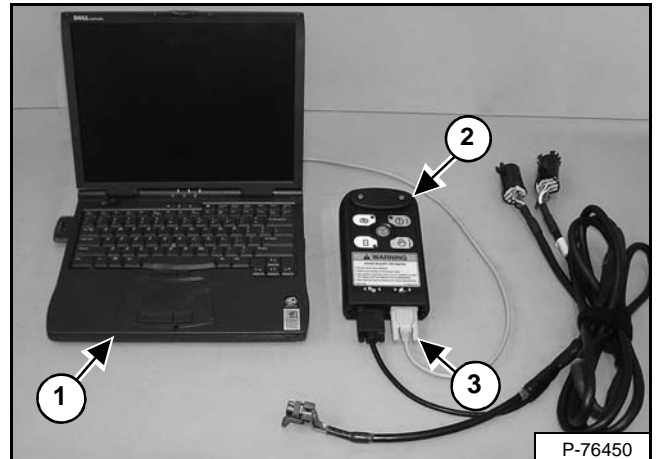

The tools listed will be needed to do the following procedure:

Order from Bobcat Parts P/N: 7003031 - Remote Start Tool (Service Tool) Kit

Kit Includes:

7003030 - Remote Start Tool (Service Tool)
6689747 - Loader Service Tool Harness
6689746 - Computer Service Tool Harness
6689745 - BOSS® Service Tool Harness

NOTE: Make all connections with the key in the OFF position.

The Service PC (Item 1) with the Remote Start Tool (Service Tool) (Item 2) [Figure 60-150-2]. When connected to the loader, the Service PC is used to monitor, conduct diagnostics, and upgrade software.

Connect the Remote Start Tool (Service Tool) Computer Service Tool Harness (Item 3) [Figure 60-150-2] to the designated serial port on the Service PC.

NOTE: The recommended serial cable length should not exceed 4,6 m (15 ft). A serial cable longer than 4,6 m (15 ft) will create a degraded signal causing communication errors.

Connect the other end to the connector on the Remote Start Tool (Service Tool).

Connect the Remote Start Tool (Service Tool) to the loader. (See REMOTE START TOOL (SERVICE TOOL) KIT - 7003031 on Page 10-61-1.)

NOTE: Refer to BobcatNET for PC requirements and the latest Service Analyzer software.

CALIBRATION (CONT'D)

Hydrostatic Pump Calibration (SJC) (Cont'd)

WARNING

Put jackstands under the front axles and rear corners of the frame before running the engine for service. Failure to use jackstands can allow the machine to fall or move and cause injury or death.

W-2017-0286

Figure 60-160-18

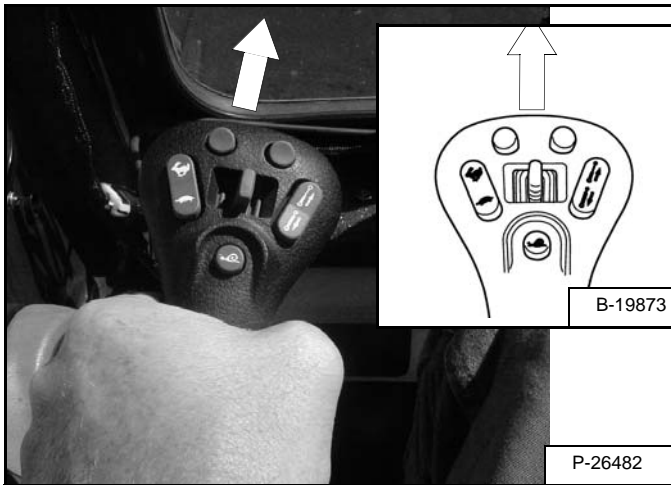

Move and hold the left joystick to the forward position [Figure 60-160-18] until the forward calibration is completed.

Figure 60-160-19

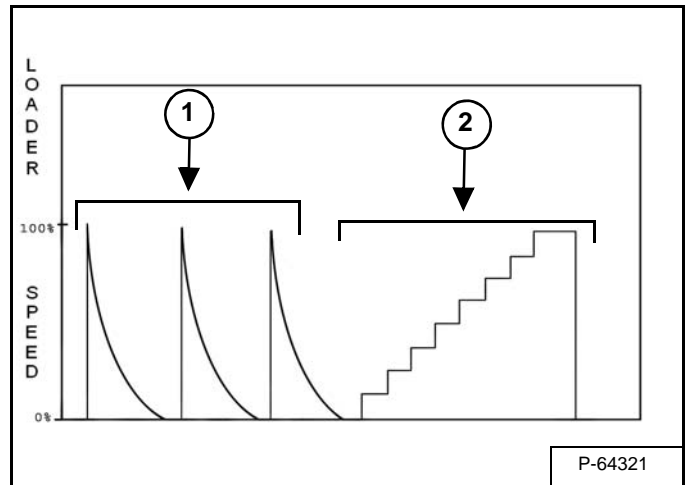

The loader speed will “ramp up” quickly (Item 1) [Figure 60-160-19] and slow down 3 times in a row.

The loader will then “stair step” the speed (Item 2) [Figure 60-160-19] until it reaches full speed and then come to a stop.

Continue to hold the left joystick in the forward position until the loader wheels or tracks come to a stop and an audible beep is heard.

Forward calibration is complete.

NOTE: If the wheels or tracks do not stop moving in Full Speed Forward in 2 minutes or less, there was an error in the calibration procedure. The operator must shut the loader OFF, and start the calibration procedure from the beginning.

PASSWORD SETUP (DELUXE INSTRUMENTATION PANEL)

Password Setup is available on machines with a Deluxe Instrumentation Panel.

Password Description

All new machines with a Deluxe Instrumentation Panel arrive at Bobcat dealerships with the keypad in locked mode. This means that a password must be used to start the engine.

For security purposes, your dealer may change the password and also set it in the locked mode. Your dealer will provide you with the password.

Master Password:

A permanent, randomly selected password set at the factory which cannot be changed. This password is used for service by the Bobcat dealer if the owner password is not known; or to change the owner password.

Owner Password:

Allows for full use of the loader and to setup the Deluxe Instrumentation Panel. There is only one owner password. It must be used to change the owner or user passwords. Owner should change the password as soon as possible for security of the loader.

User Password:

Allows starting and operating the loader; cannot change password or any of the other setup features.

For the procedures to change passwords (See Changing The Owner Password on this page) (See Changing The User Password on Page 60-190-2.)

Changing The Owner Password

Figure 60-190-1

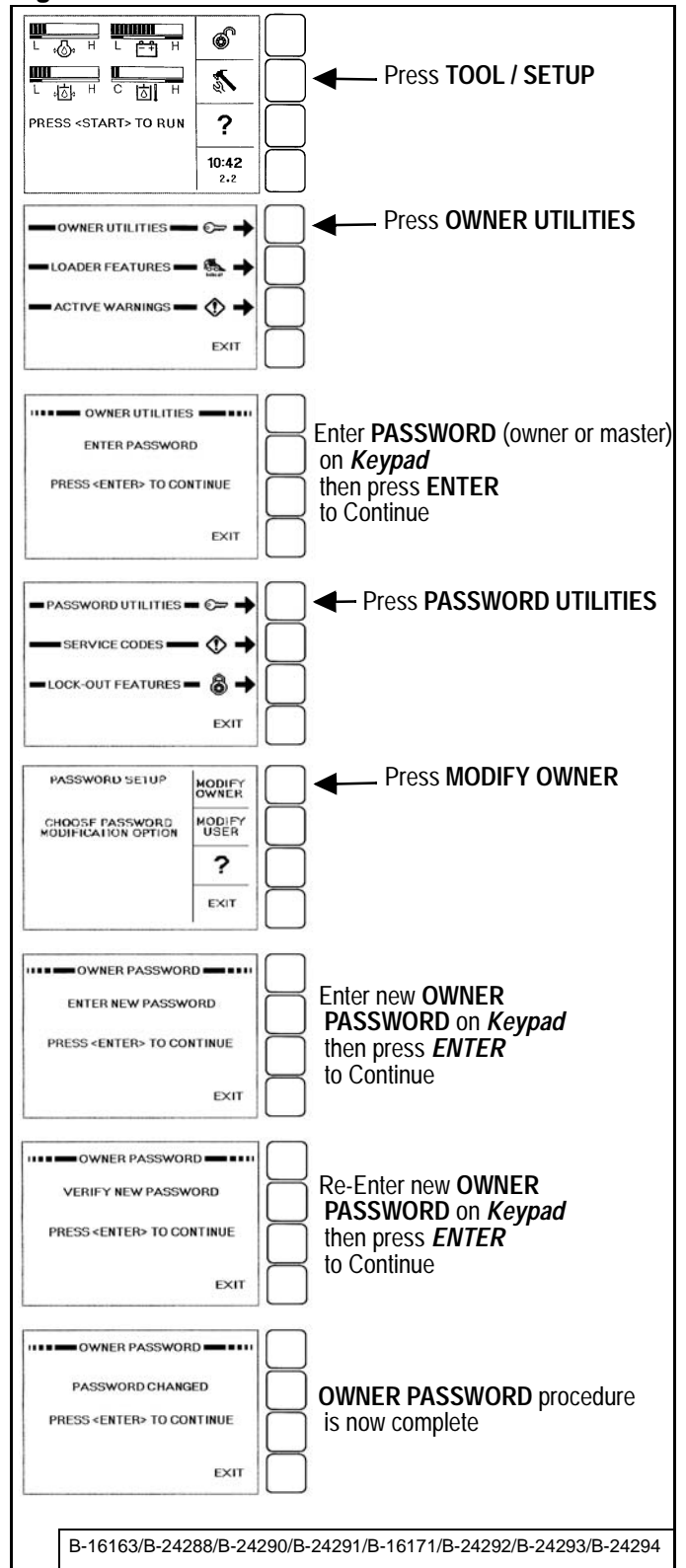

BACK-UP ALARM SYSTEM

Description

This machine may be equipped with a back-up alarm system. The back-up alarm will sound when the operator moves both steering levers or joystick(s) into the reverse position. Slight movement of the steering levers into the reverse position is required with hydrostatic transmissions, before the back-up alarm will sound.

Inspecting

Figure 60-210-1

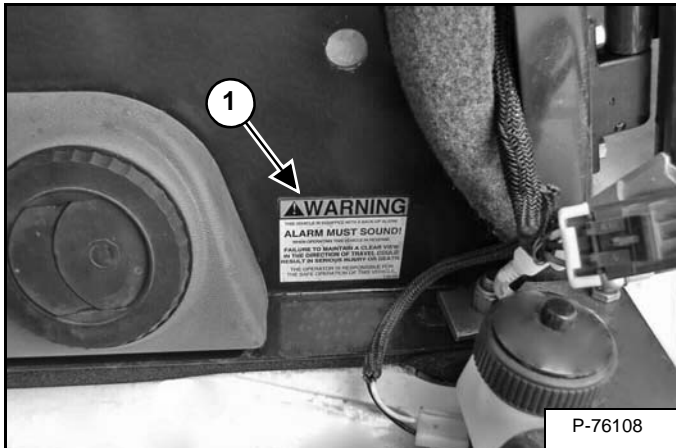

Inspect for damaged or missing back-up alarm decal (Item 1) [Figure 60-210-1]. Replace if required.

Sit in the seat and fasten the seat belt. Engage the parking brake. Pull the seat bar all the way down. Start the engine. Press the PRESS TO OPERATE LOADER button. Disengage the parking brake.

Move both steering levers or joystick(s) into the reverse position. The back-up alarm must sound when all wheels or both tracks are moving in reverse.

The back-up alarm is located on the inside of the rear door.

Figure 60-210-2

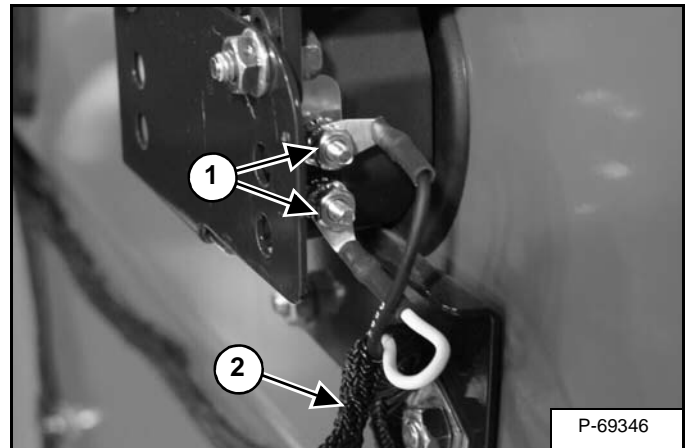

Inspect the back-up alarm electrical connections (Item 1) [Figure 60-210-2], wire harness (Item 2) [Figure 60-210-2] and back-up alarm switches (if equipped) (Item 2) [Figure 60-210-3] for tightness and damage. Repair or replace any damaged components.

If the back-up alarm switches require adjustment, (See Adjusting Switch Position on Page 60-210-2.)

ENGINE INFORMATION

Description

The S185 has a Kubota direct injected V2607-DI-T turbo diesel engine with a displacement of 2,6 L (158.7 in³). The engine is rated at an SAE Net 43,3 kW (58 hp) and has a closed crankcase ventilation system **[Figure 70-10-1]**.

The engine has 4 cylinders and the rotation is counter-clockwise (viewed from the flywheel side). It is equipped with glow plugs for assisting in cold starts. Engine block heaters are also available from Bobcat Parts. To meet emission regulations it is also equipped with an Exhaust Gas Recirculation (EGR) system to reduce Nitrogen Oxide (NOx).

The engine serial number is stamped on the engine and is located near the injection pump. The model number is located on the valve cover. Use these numbers to obtain the correct service parts.

The engine is liquid cooled with a propylene glycol / water mixture in a radiator. Coolant flow is controlled by a thermostat. The cooling fan is driven by a hydraulic motor. The speed of the fan is determined by the engine coolant temperature sensor and the hydraulic / hydrostatic fluid temperature sensor.

Figure 70-10-1

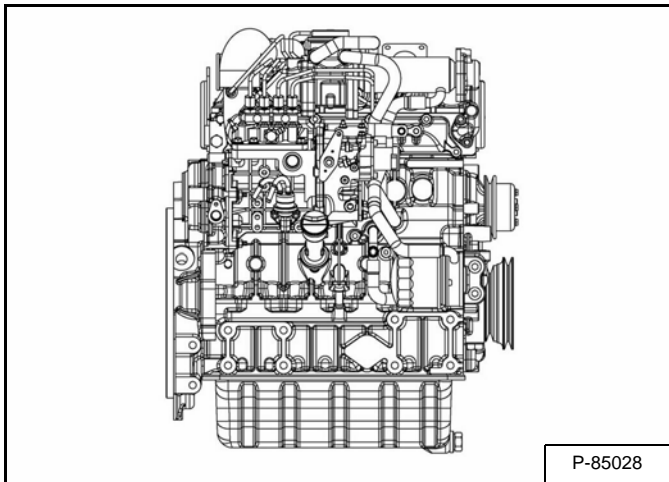

ENGINE INFORMATION (CONT'D)

Engine Removal And Installation (Cont'd)

Figure 70-10-12

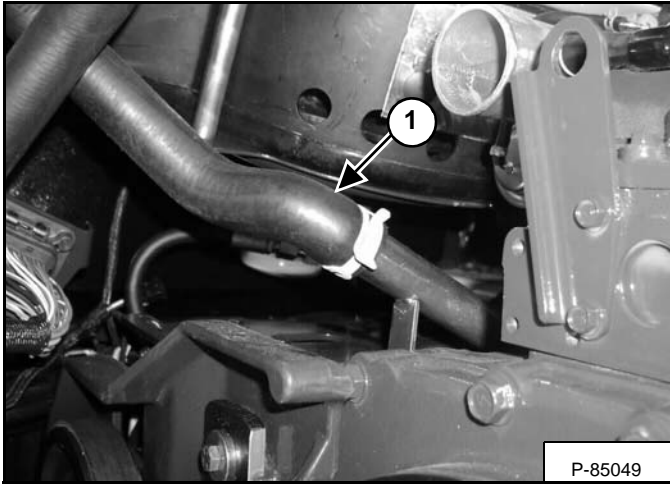

Disconnect engine coolant hose (Item 1) [Figure 70-10-12].

Cap or plug all hoses and fittings.

Figure 70-10-13

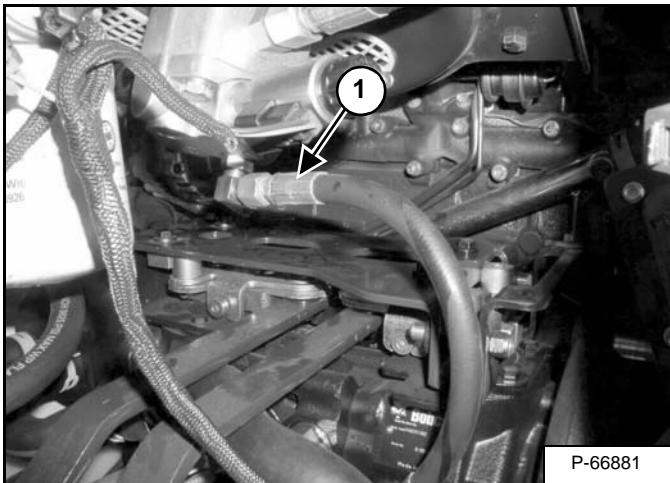

Disconnect drain hose (Item 1) [Figure 70-10-13] from the hydraulic cooling fan.

Cap or plug all hoses and fittings.

Figure 70-10-14

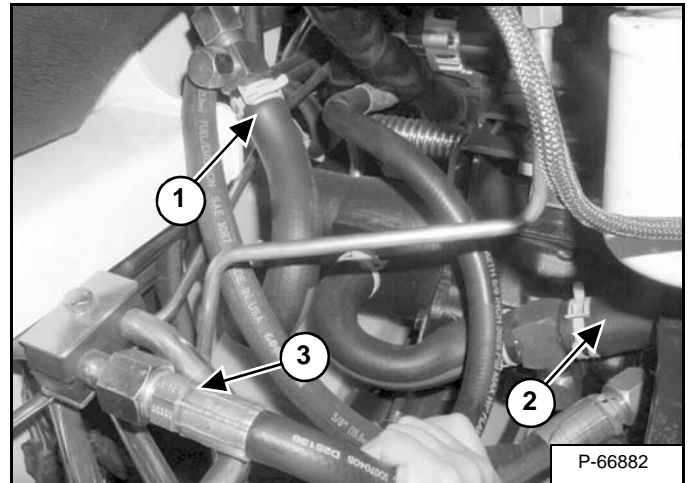

Disconnect gear pump inlet hose (Item 1) [Figure 70-10-14].

Disconnect supply hose (Item 2) [Figure 70-10-14] from hydraulic fluid reservoir.

Disconnect gear pump outlet hose (Item 3) [Figure 70-10-14].

Cap or plug all hoses and fittings.

Figure 70-10-15

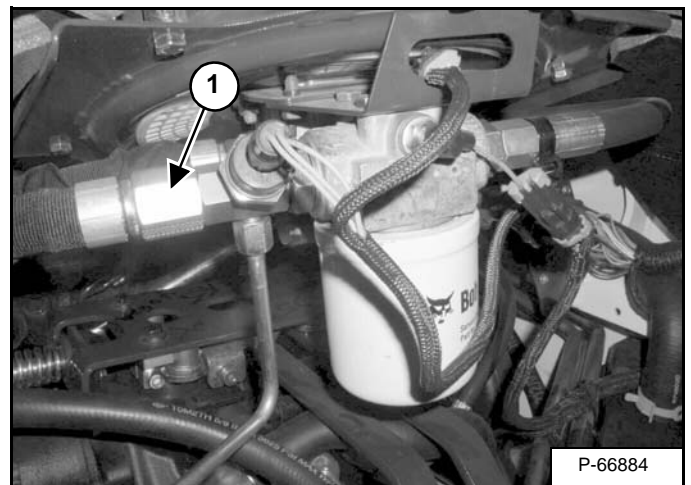

Mark and disconnect the charge pump / fan filter outlet hose (Item 1) [Figure 70-10-15].

Cap or plug all hoses and fittings.

ENGINE SPEED CONTROL (SJC) (CONT'D)

Removal And Installation (Cont'd)

Figure 70-21-8

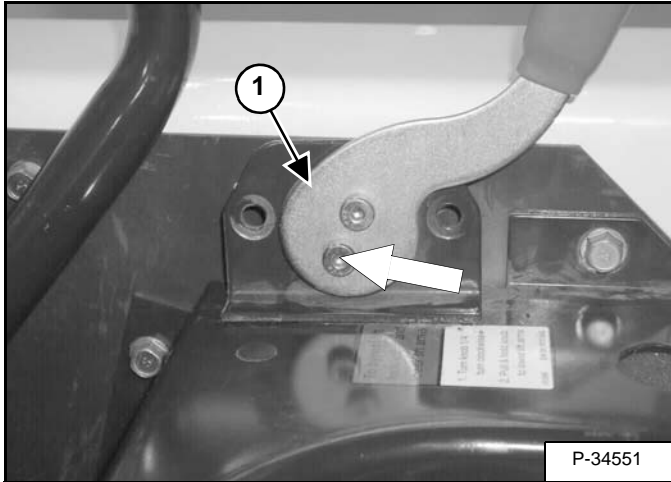

At the bottom side of the control panel, move the speed control linkage toward the rear of the loader.

Slide the hand speed control lever (Item 1) [Figure 70-21-8] forward and lift, and disconnect the assembly from the speed control cable.

Figure 70-21-9

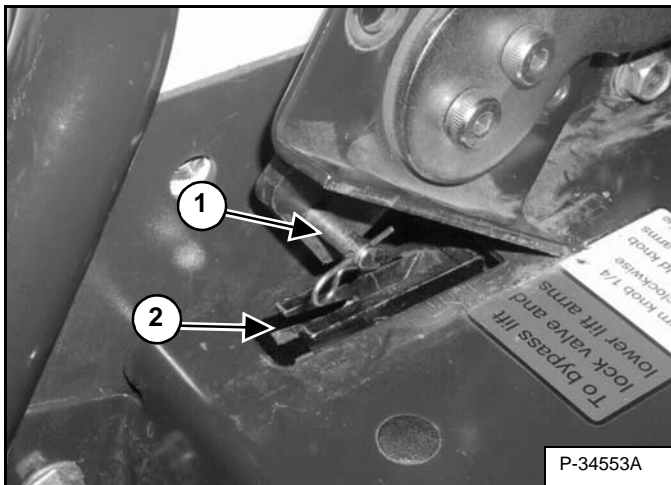

Installation: When installing the hand speed control to the speed control cable, be sure the speed control lever (Item 1) fits in the notch (Item 2) [Figure 70-21-9] of the speed control rod clevis.

Disassembly And Assembly

Figure 70-21-10

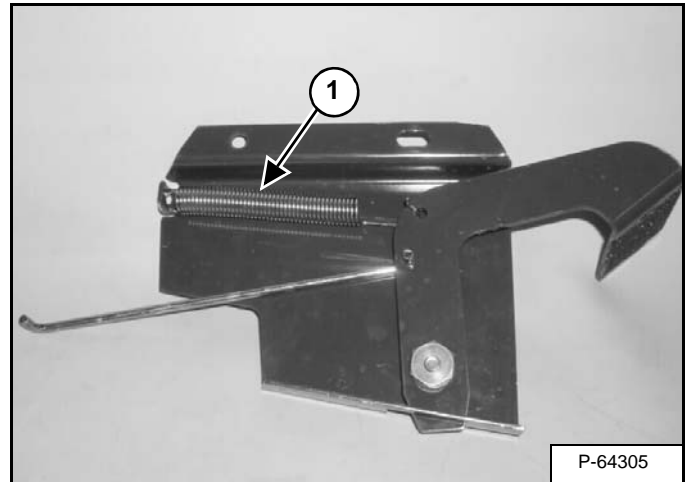

Remove the spring (Item 1) [Figure 70-21-10] from the foot speed control assembly.

Figure 70-21-11

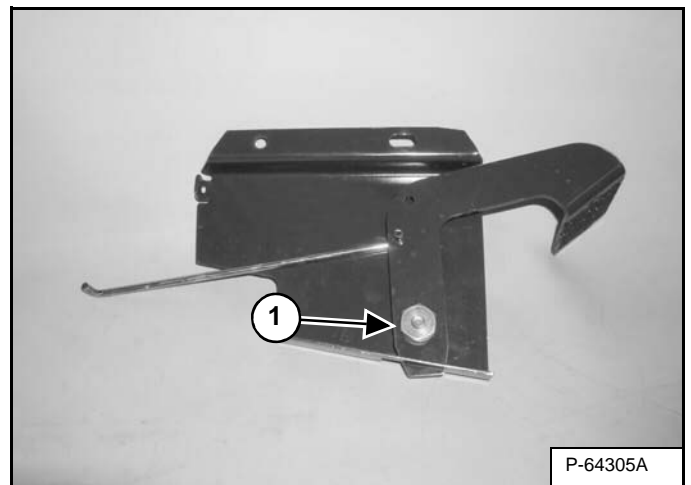

Remove the bushing / nut (Item 1) [Figure 70-21-11] from the pedal lever.

ENGINE COOLING SYSTEM (CONT'D)

Blower Housing Removal And Installation (S/N A3L929999 & Below And A3LH29999 & Below)

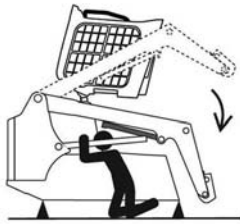

P-90328

AVOID DEATH

- Disconnecting or loosening any hydraulic tubeline, hose, fitting, component or a part failure can cause lift arms to drop.
- Keep out of this area when lift arms are raised unless supported by an approved lift arm support. Replace if damaged.

D-1009-0409



Never work on a machine with the lift arms up unless the lift arms are secured by an approved lift arm support device. Failure to use an approved lift arm support device can allow the lift arms or attachment to fall and cause injury or death.

W-2059-0598



When repairing hydrostatic and hydraulic systems, clean the work area before disassembly and keep all parts clean. Always use caps and plugs on hoses, tubelines and ports to keep dirt out. Dirt can quickly damage the system.

I-2003-0888

Raise the lift arms and install an approved lift arm support device. (See Installing on Page 10-20-1.)

Raise the operator cab.(See Raising on Page 10-30-1.)

Remove the fan motor / charge pump filter housing. (See Charge Filter Housing Removal And Installation on Page 20-80-3.)

Figure 70-50-10

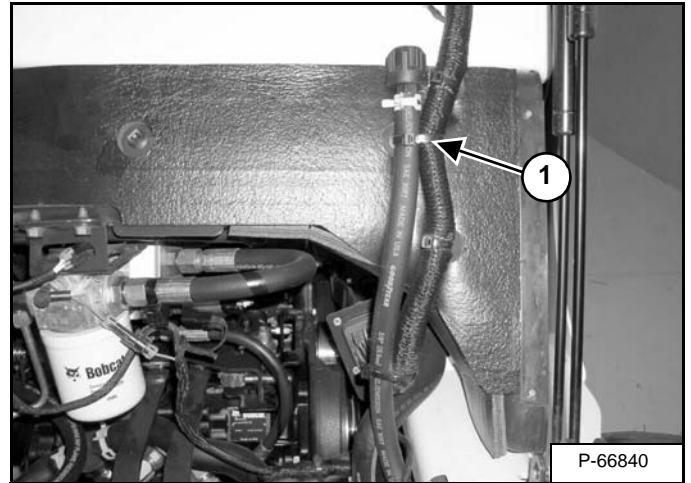

Remove cable ties (Item 1) [Figure 70-50-10] attached to blower housing.

Figure 70-50-11

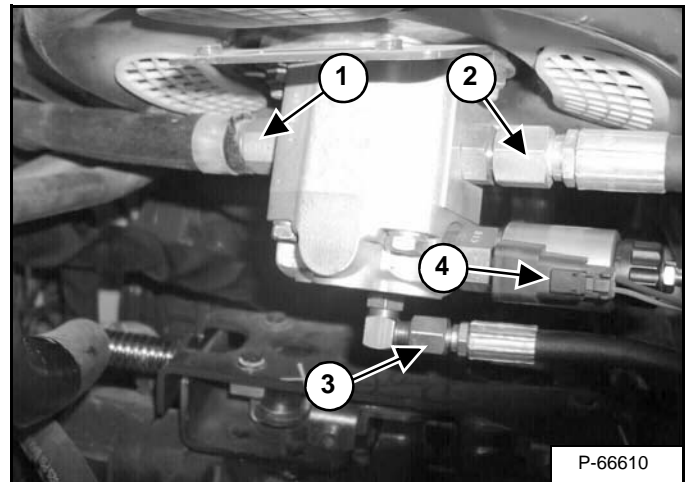

Remove the fan motor inlet hose (Item 1) and outlet hose (Item 2) [Figure 70-50-11].

Remove the fan case drain hose (Item 3) [Figure 70-50-11].

Disconnect the electrical connector (Item 4) [Figure 70-50-11].

ENGINE COOLING SYSTEM (CONT'D)

Thermostat - Checking

Figure 70-50-35

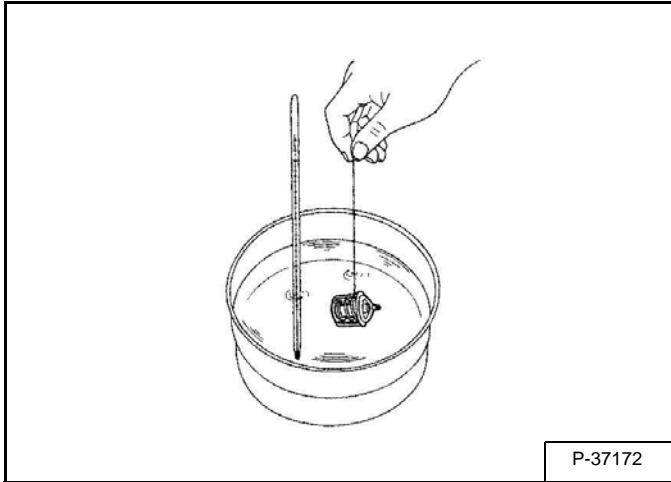

Push down the thermostat valve and insert a string between the valve and the valve seat.

Place the thermostat and a thermometer in a container with water and gradually heat the water **[Figure 70-50-35]**.

Hold the string to suspend the thermostat in the water. When the water temperature rises, the thermostat valve will open, allowing it to fall down from the string.

Continue heating the water and read the temperature when the valve has risen by about 8 mm (0.315 in).

If the measurement is not acceptable, replace the thermostat.

Thermostat's valve opening temperature	Factory spec.	80 - 84°C 176 - 183°F
Temperature at which thermostat completely opens	Factory spec.	95°C 203°F

FUEL SYSTEM (CONT'D)

Fuel Injection Pump Assembly Removal And Installation (Cont'd)

Figure 70-70-13

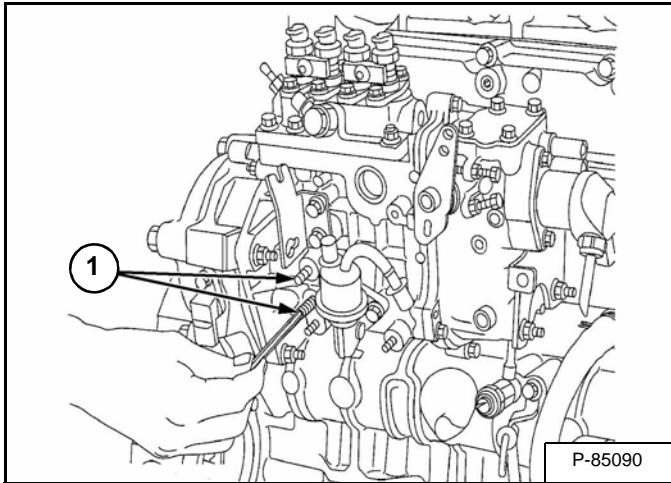

Install one lock tool in the upper plug opening (Item 1) and tighten until it comes in contact with the fuel camshaft. Make sure the fuel camshaft is not moving. Install second lock tool in lower opening (Item 1) [Figure 70-70-13] and repeat the process.

NOTE: Do not over tighten the lock screws after they have contacted the fuel camshaft. Otherwise the injection pump may become damaged.

Figure 70-70-14

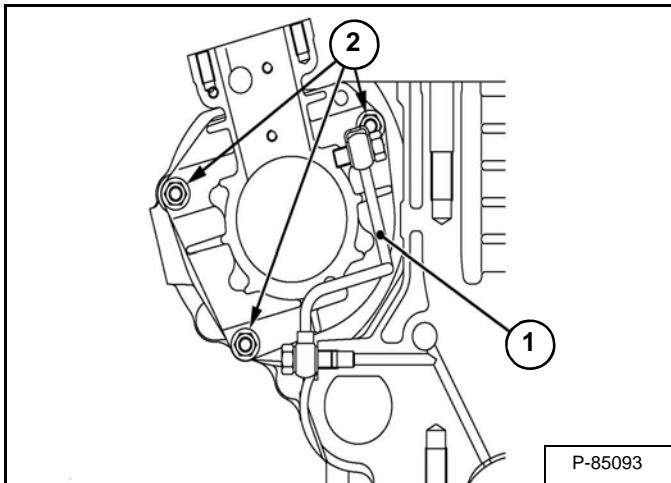

Remove the lubricating oil pipe (Item 1) [Figure 70-70-14].

Remove the three injection pump mounting nuts (Item 2) [Figure 70-70-14]

Installation: Tighten the lubricating oil pipe to 16 - 19 N•m (12 - 14 ft-lb) torque.

Installation: Tighten the injection pump mounting nuts to 18 - 20 N•m (13 - 15 ft-lb) torque.

Figure 70-70-15

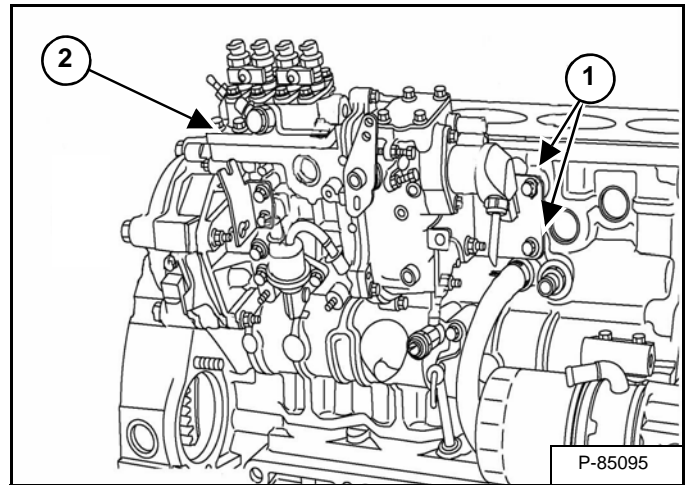

Remove injection pump support (Item 1) [Figure 70-70-15].

Remove injection pump assembly (Item 2) [Figure 70-70-15].

Installation: Reverse procedure to install.

FUEL SYSTEM (CONT'D)

Injection Pump - Timing (Cont'd)

Figure 70-70-42

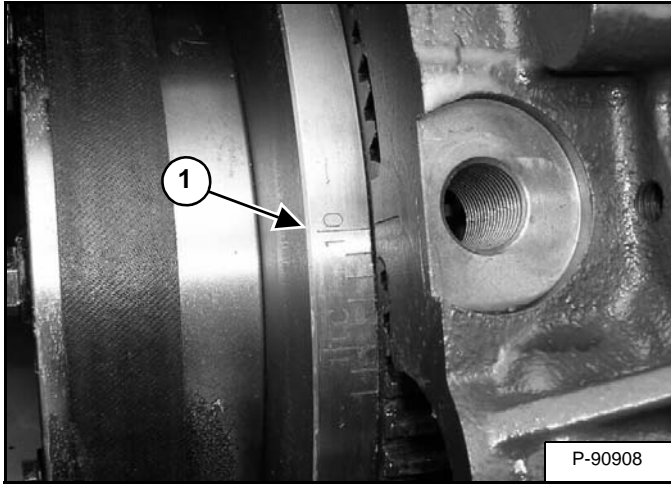

Next turn the flywheel counterclockwise to 0,17 rad (10°) before top dead center (Item 1) [Figure 70-70-42].

Then slowly turn the flywheel counterclockwise and stop turning when the fuel just begins to come up the holder (Item 2) [Figure 70-70-41] to get the present injection timing.

Figure 70-70-43

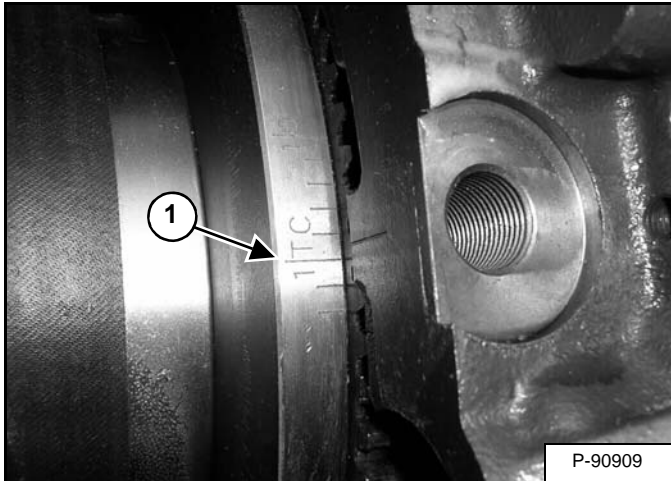

Check the degree marks on the flywheel. The flywheel has a 1TC mark (Item 1) [Figure 70-70-43] that indicates top dead center for cylinder number one. Each mark on the flywheel is 2 degrees.

NOTE: If the injection pump timing is not within the specification, then rotate the injection pump assembly upwards to advance, or downwards to retard the injection pump timing. Rotating the pump 0,64 mm (0.025 in) is equal to approximately 1 degree.

The table below lists the fuel timing specification, based on the engine serial number.

KUBOTA V2607T	RANGE	SETTING
ENGINE S/N 8W0001 & Above	1.00° B.T.D.C. TO 0.50° A.T.D.C	1.00° B.T.D.C.
ENGINE S/N 8G0001 - 8V9999	0.50° B.T.D.C. TO 1.00° A.T.D.C.	0.50° B.T.D.C.

NOTE: Set the timing to the advanced end of the specification range [Figure 70-70-44]. An engine timed after top dead center will exhibit long cranking times on initial startup in cold temperatures.

Figure 70-70-44

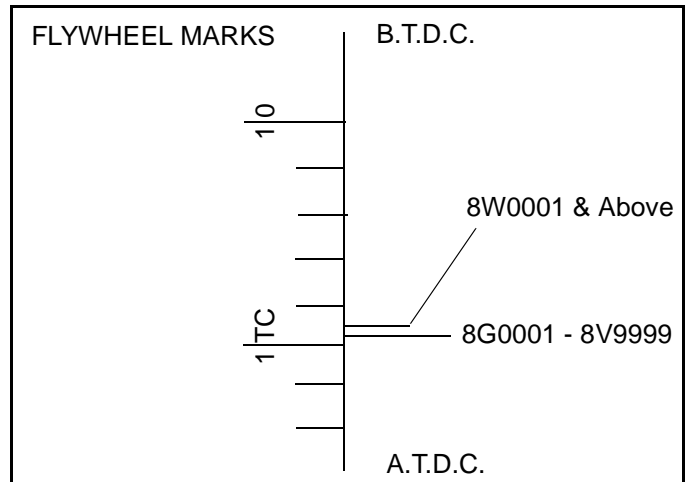

When timing is correct tighten the three injection pump mounting bolts to 19 N•m (14 ft-lb) torque.

CYLINDER HEAD (CONT'D)

Cylinder Head Disassembly And Assembly

Figure 70-80-23

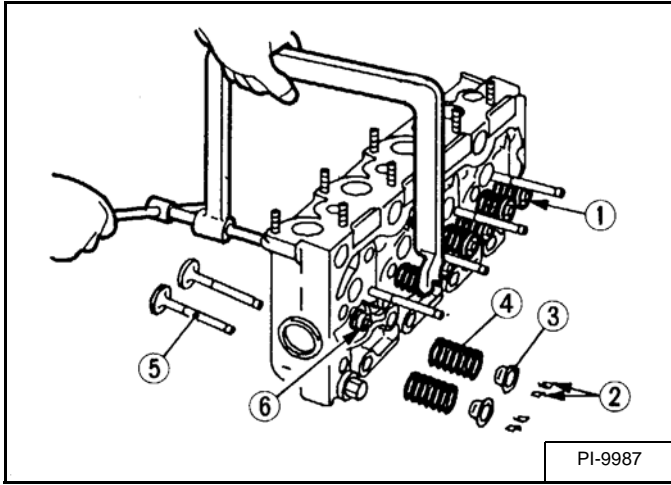

Use a valve spring compressor to compress the valve spring [Figure 70-80-23].

Figure 70-80-24

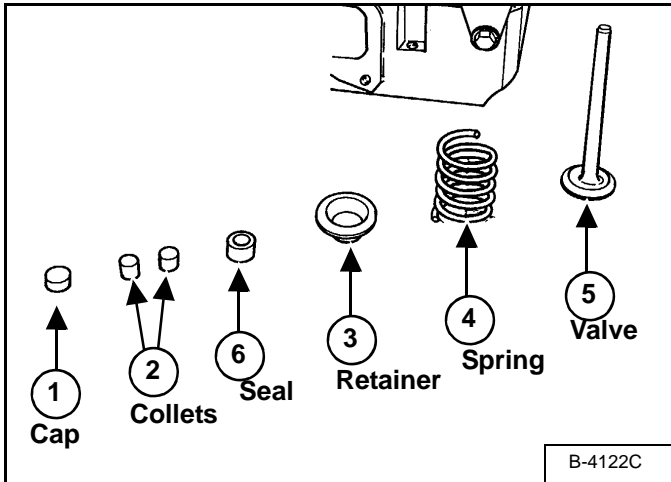

Remove the valve cap (Item 1) and valve spring collet (Item 2) [Figure 70-80-23] and [Figure 70-80-24].

Remove the valve spring retainer (Item 3) and the spring (Item 4) [Figure 70-80-23] and [Figure 70-80-24].

Remove the seal (Item 6) and the valve (Item 5) [Figure 70-80-23] and [Figure 70-80-24].

Cylinder Head - Servicing

Clean the surface of the cylinder head.

Figure 70-80-25

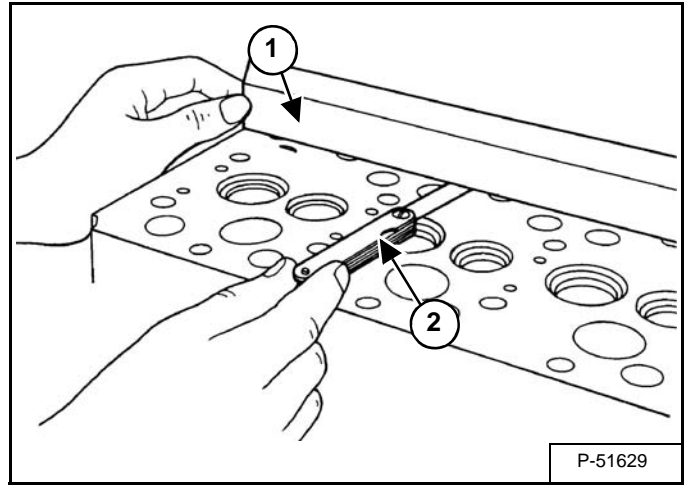

Put a straight edge (Item 1) [Figure 70-80-25] on the cylinder head.

NOTE: Do not put the straight edge across combustion chambers.

Put a feeler gauge (Item 2) [Figure 70-80-25] between the straight edge and the surface of the cylinder head.

Figure 70-80-26

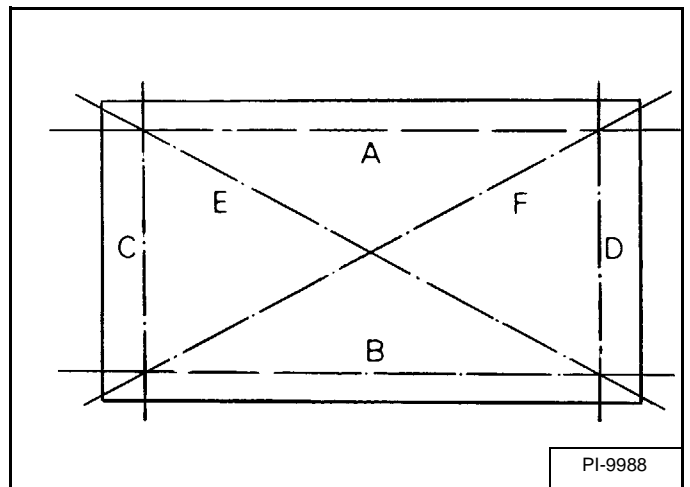

Put the straight edge on the cylinder head's four sides and two diagonal as shown in figure [Figure 70-80-26].

The maximum distortion of the head surface is $\pm 0,05$ mm (± 0.002 in). If the measurement exceeds the specification, replace the cylinder head.

CRANKSHAFT AND PISTONS

Piston And Connecting Rod Removal And Installation

Remove the cylinder head. (See Cylinder Head Removal And Installation on Page 70-80-4.)

Remove the top edge from the cylinder bore with a ridge reamer.

Remove the oil pan and oil pump strainer. (See Oil Pan Removal And Installation on Page 70-60-1.)

Figure 70-90-1

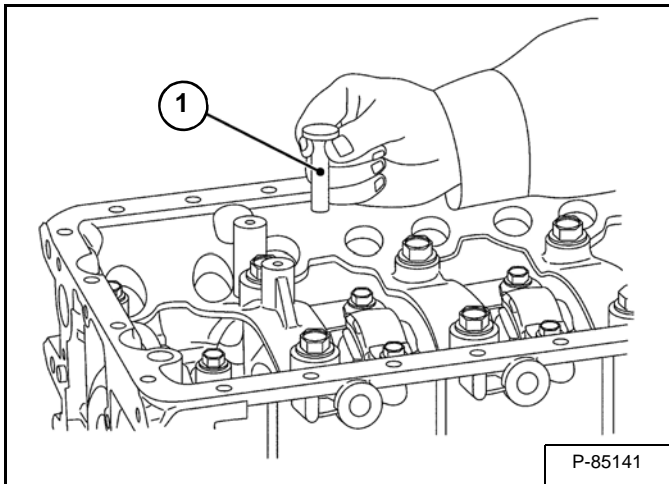
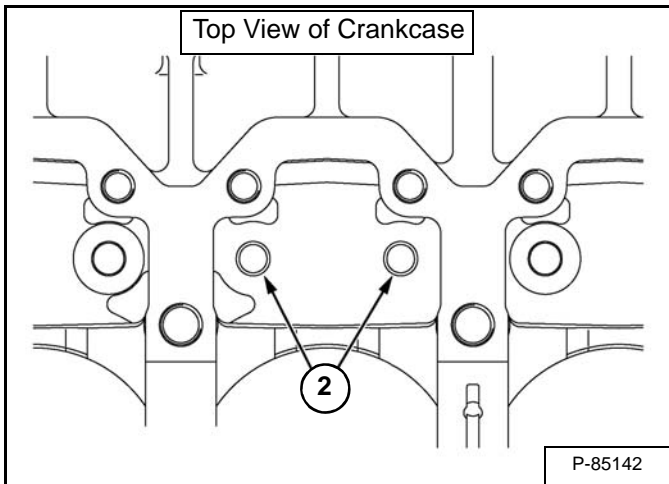

Figure 70-90-2



Remove the tappet (Item 1) [Figure 70-90-1] from the tappet bore (Item 2) [Figure 70-90-2] using a magnetic tool.

Installation: Apply engine oil to the tappet during installation.

NOTE: Mark the location of the tappets to prevent them from becoming interchanged.

Figure 70-90-3

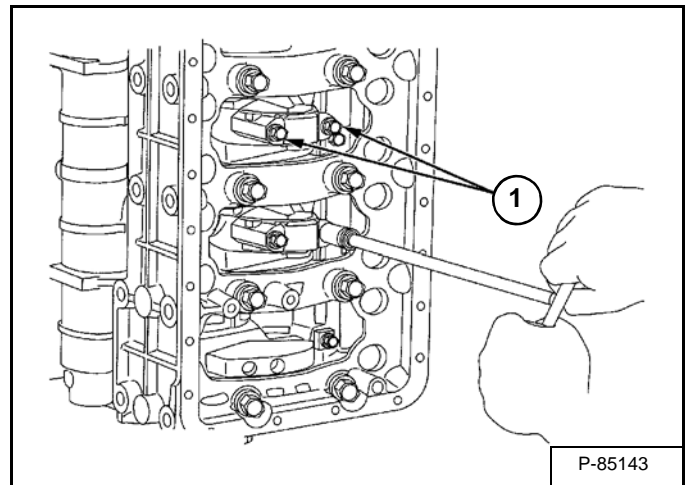

Remove the connecting rod bolts (Item 1) [Figure 70-90-3].

NOTE: Mark the location of the rod bearings to prevent them from becoming interchanged.

Installation: Tighten the connecting rod bolts to 44 - 49 N•m (33 - 36 ft-lb) torque.

Installation: Apply engine oil to the connecting rod bolts and lightly screw in by hand.

Installation: Install the rod bearing with the centrally lined groove towards the connecting rod, and the non grooved side towards the cap.

Installation: Make sure the marks on the connecting rod and bearing are aligned and facing the injection pump when installing the bearing cap.

CRANKSHAFT AND PISTONS (CONT'D)

Crankshaft And Bearings - Servicing

Figure 70-90-28

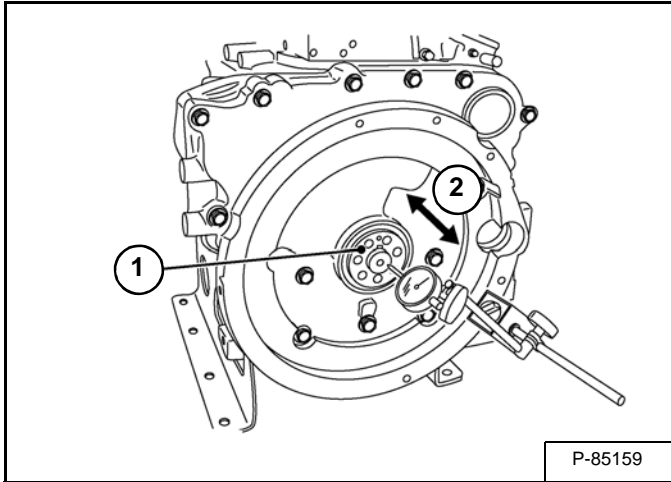

Set a dial indicator with its tip on the end of the crankshaft (Item 1) [Figure 70-90-28].

Measure the side clearance by moving the crankshaft side to side (Item 2) [Figure 70-90-28].

If the misalignment exceeds the allowable limit, replace the crankshaft.

Side clearance of crankshaft	Factory Spec.	0,15 - 0,35 mm (0.0059 - 0.013 in)
	Allowable limit	0,50 mm (0.020 in)

Figure 70-90-29

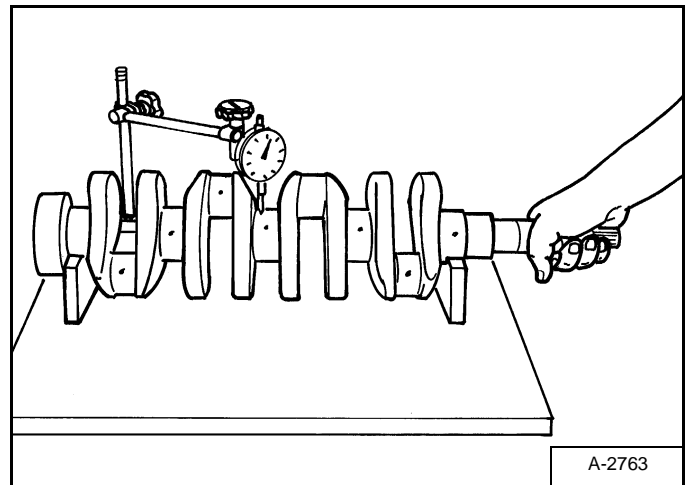

Put the crankshaft on V-blocks. Install a dial indicator on the center journal [Figure 70-90-28].

Turn the crankshaft at a slow rate to obtain the misalignment (one half of the alignment measurement).

If the misalignment exceeds the allowable limit, replace the crankshaft.

Alignment	0,02 mm (0.0008 in)
-----------	---------------------

CAMSHAFT AND TIMING GEARS (CONT'D)

Camshaft - Servicing (Cont'd)

Figure 70-100-14

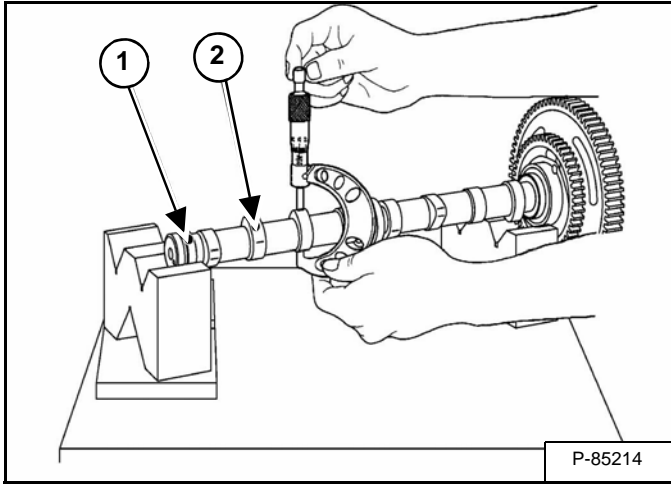

Measure the cam lobes at their highest point (Item 2) [Figure 70-100-14].

If the measurement is less than the allowable limit, replace the camshaft (Item 1) [Figure 70-100-14].

Cam Lobe Height Intake	32,56 mm (1.282 in)
Cam Lobe Height Exhaust	33,00 mm (1.299 in)
Allowable Limit Intake	32,10 mm (1.264 in)
Allowable Limit Exhaust	32,50 mm (1.280 in)

Figure 70-100-15

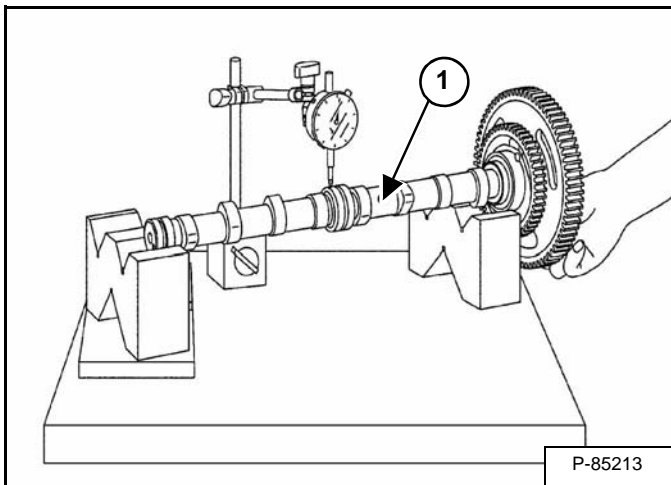

Put the camshaft (Item 1) in V-blocks. Install a dial indicator [Figure 70-100-15].

Turn the camshaft at a slow rate. If the misalignment exceeds the allowable limit, replace the camshaft.

Camshaft Alignment Allowable Limit	0,01 mm (0.0004 in)
------------------------------------	------------------------

Idler Gear And Shaft - Servicing

Figure 70-100-16

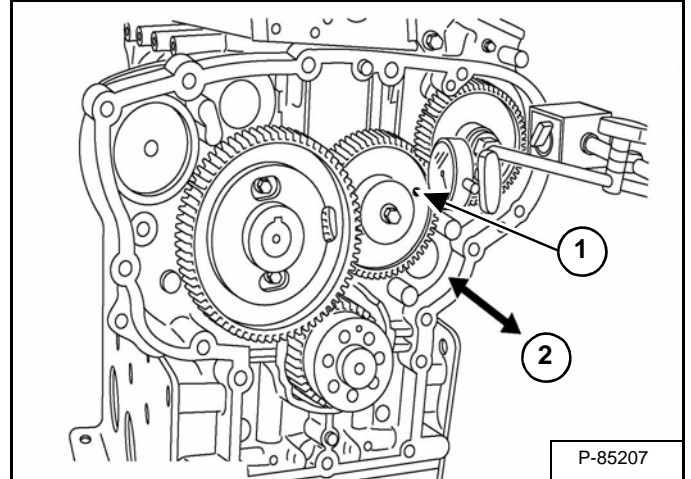

Mount a dial indicator and check idler gear (Item 1) end play (Item 2) [Figure 70-100-16].

Installation: Check the idler gear end play. If the clearance exceeds the allowable limit, replace the gear collar.

Idler Gear End Play	0,050 - 0,020 mm (0.0020 - 0.0078 in)
Allowable Limit	0,90 mm (0.035 in)

EXHAUST GAS RECIRCULATION (EGR) SYSTEM (CONT'D)

Testing (Cont'd)

Figure 70-130-3

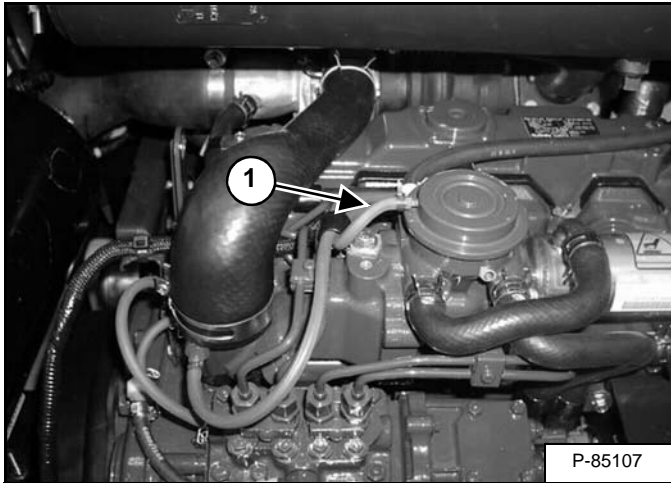

Disconnect the boost hose (Item 1) [Figure 70-130-3] from the EGR valve.

Figure 70-130-4

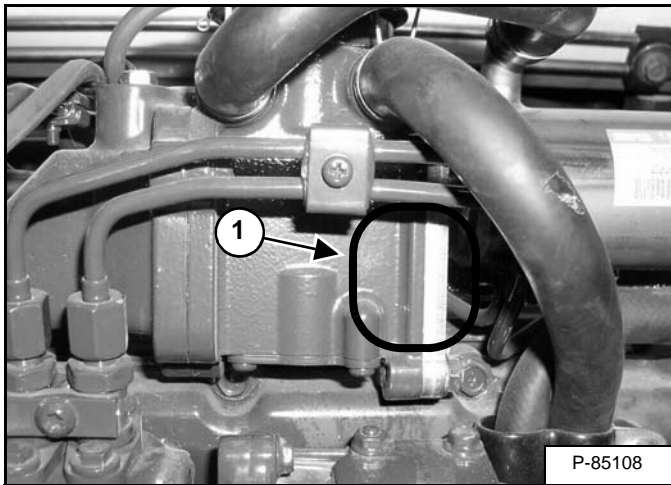

Measure the surface temperature of the EGR system (Item 1) [Figure 70-130-4] with an Infrared Thermometer.

If the surface temperature of the EGR system declines, the thermo valve has failed.

If the surface temperature of the EGR system stays above 100°C (212°F), the EGR valve has failed.

Hot Engine Coolant Temperature Test

Verify the engine temperature is above 70°C (158°F), if the engine temperature is below 70°C (158°F) run the engine to bring the temperature above 70°C (158°F) then continue with the Hot Engine Coolant Temperature Test.

Figure 70-130-5

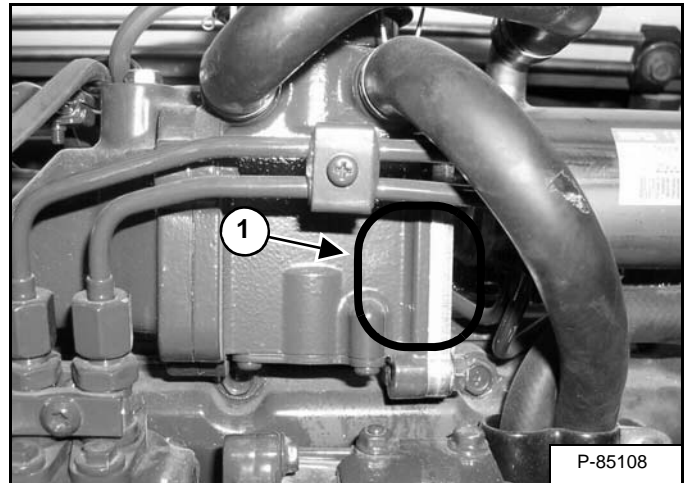

Measure the surface temperature of the EGR system (Item 1) [Figure 70-130-5] with an Infrared Thermometer.

With the engine coolant temperature above 70°C (158°F) and the surface temperature of the EGR system 100°C (212°F) or above, the EGR system is OK.

If the surface temperature of the EGR system is 50°C (122°F) or below continue this Hot Engine Coolant Temperature Test.

Figure 70-130-6

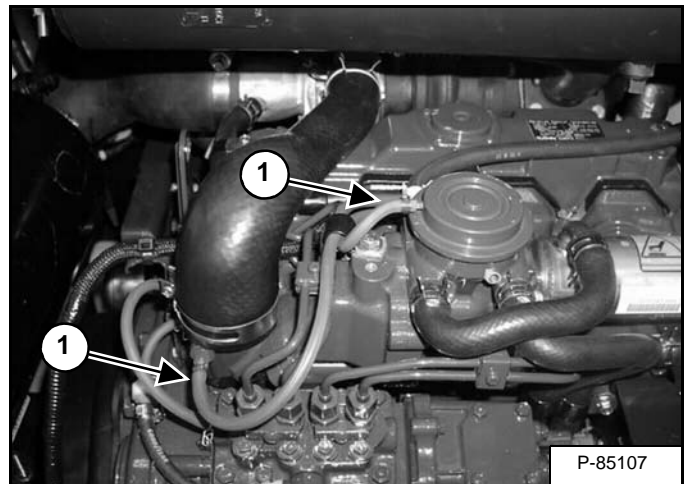

Disconnect the two hoses (Item 1) [Figure 70-130-6].

TROUBLESHOOTING (CONT'D)

Troubleshooting Tree (Cont'd)

Air Conditioning

Continued on previous page.

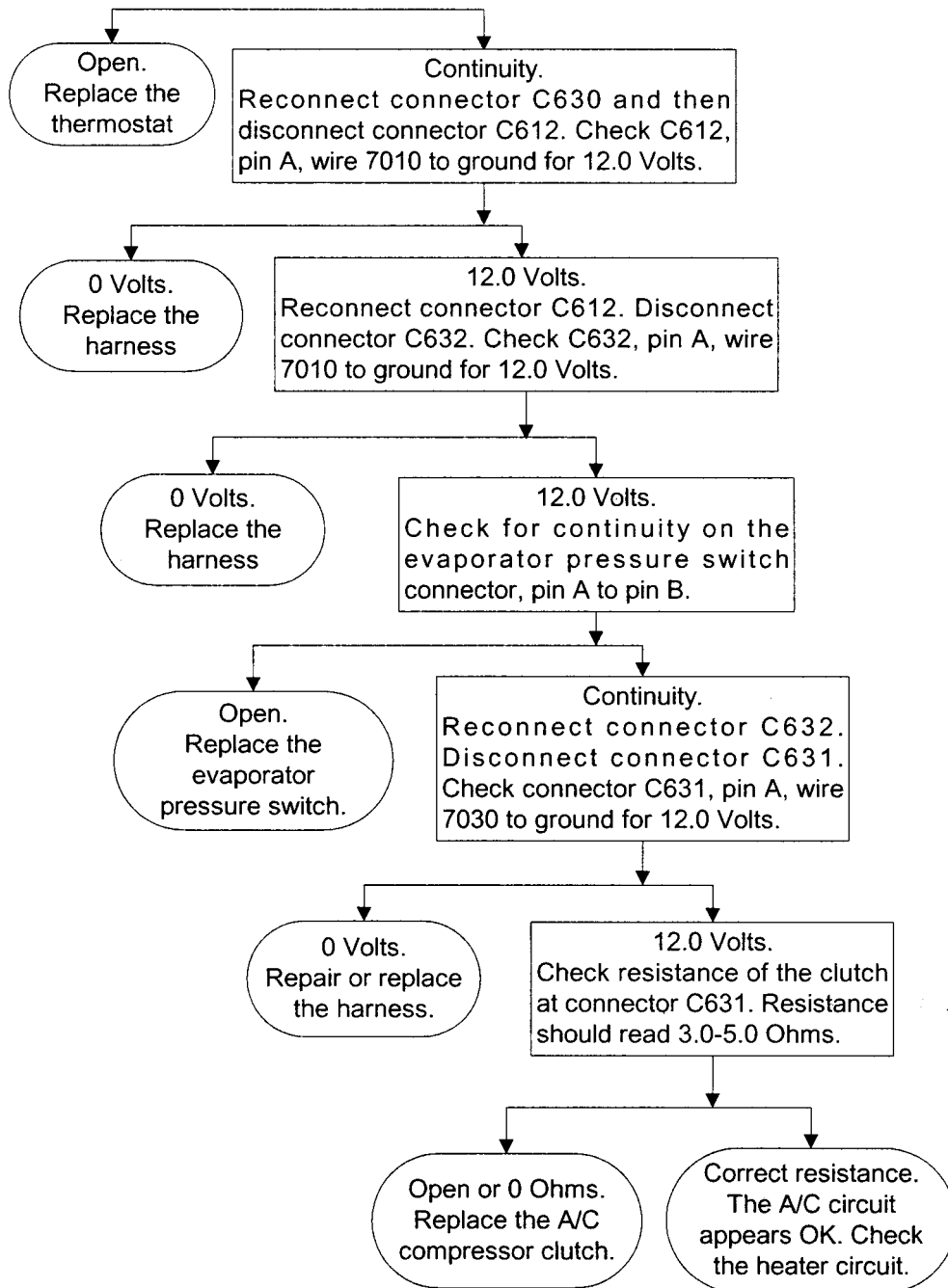

TROUBLESHOOTING (CONT'D)

Electrical System (Cont'd)

Figure 80-30-18



Remove the control panel and wiring harness from the cab [Figure 80-30-18].

Figure 80-30-19

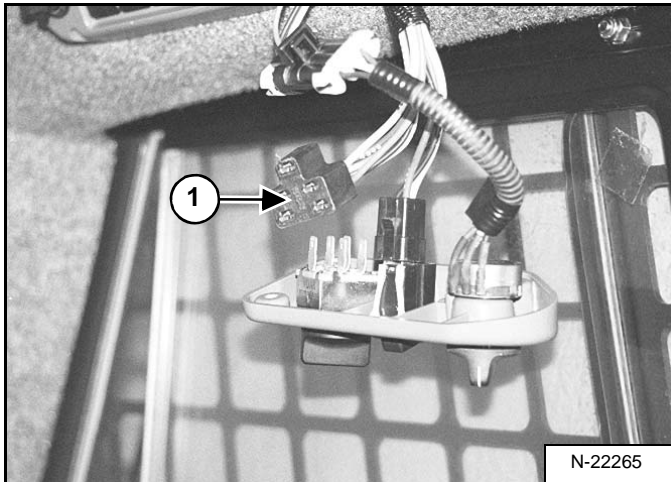

Disconnect the loader wiring harness (Item 1) [Figure 80-30-19] from the blower switch.

Check the loader harness for voltage. The voltage should be 12 volts.

If there is no voltage at the wiring harness, check the harness for broken wires.

Figure 80-30-20

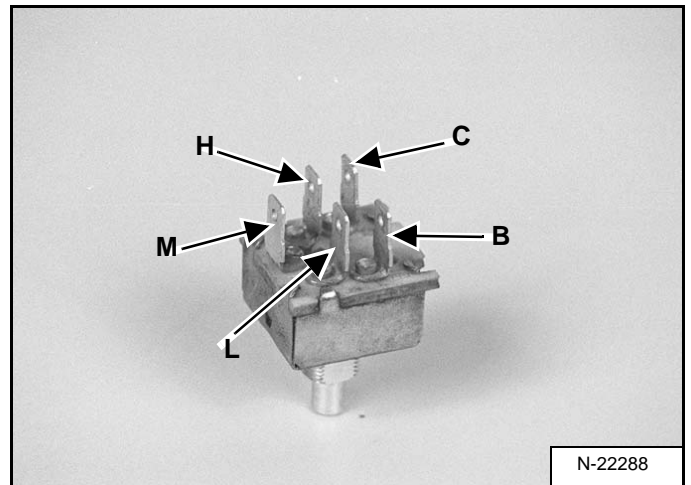

If there is voltage at the wiring harness, check the blower switch [Figure 80-30-20] for resistance.

With the switch in the OFF position, there should be zero resistance between all terminals.

With the switch in the 1 position, there should be resistance between C terminal and the B terminal, between the C terminal and the L terminal, and also between the B terminal and the L terminal frame [Figure 80-30-20].

With the switch in the 2 position, there should be resistance between C terminal and the B terminal, between the C terminal and the M terminal, and also between the B terminal and the M terminal frame [Figure 80-30-20].

With the switch in the 3 position, there should be resistance between C terminal and the B terminal, between the C terminal and the H terminal, and also between the B terminal and the H terminal frame [Figure 80-30-20].

If any of the above resistance tests fail, replace the blower switch.

If the above resistance tests are good, check the A/C switch.

SYSTEM CHARGING AND RECLAMATION (CONT'D)

Charging With A Manifold Gauge Set (Cont'd)

Figure 80-40-12

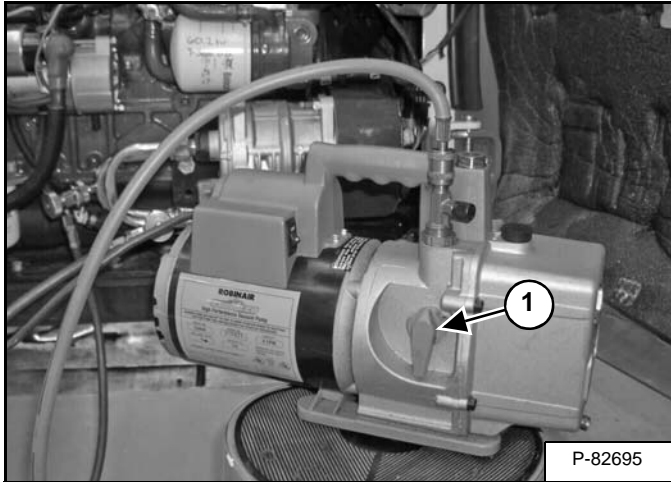

Start the vacuum pump and open ISO-valve (Item 1) [Figure 80-40-12] on the vacuum pump.

Run the vacuum pump for at least 5 - 10 minutes to insure that a vacuum has been pulled on the system.

Close the ISO-valve (Item 1) [Figure 80-40-12] (which isolates the vacuum pump from the A/C system) and turn OFF the vacuum pump.

Figure 80-40-13

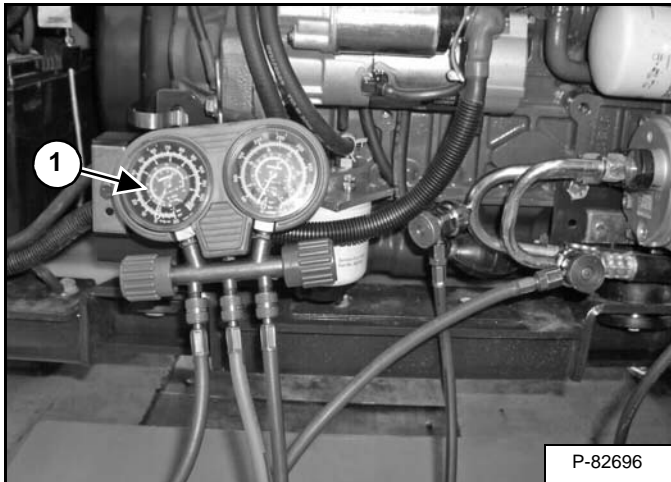

NOTE: Vacuum pressure indicated on the low pressure (Blue) gauge (Item 1) [Figure 80-40-13]. Let stand for 5 - 10 minutes and recheck the pressure for changes.

If the pressure drops, this may be an indication of a leak in the A/C system.

Determine the problem with the A/C system and repair it.

Figure 80-40-14

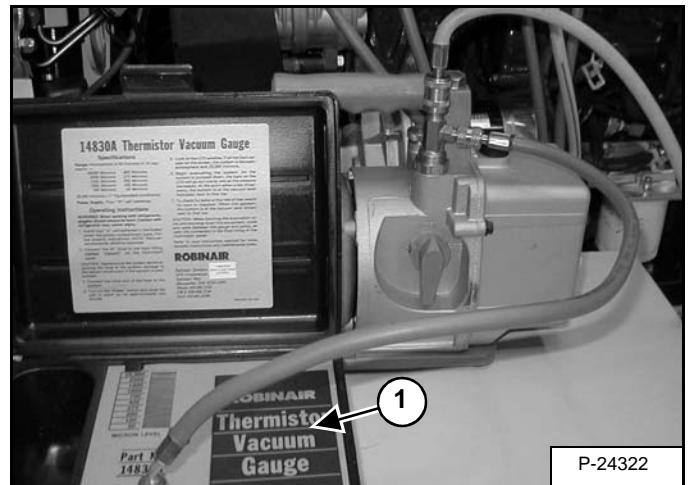

A thermistor vacuum gauge (Item 1) [Figure 80-40-14] can be used to determine the critical vacuum level during evacuation. It is a solid state instrument that constantly monitors and visually indicates the vacuum level.

The thermistor vacuum gauge is used with the vacuum pump [Figure 80-40-14].

Start the vacuum pump and open ISO-valve on the vacuum pump.

Be sure that both hand valves, and both charge port valves are open.

Run the vacuum pump for at least 45 minutes to insure that all the moisture is boiled out of the system.

Stop the vacuum pump and close the ISO-valve on the vacuum pump.

Close both hand valves on the manifold gauge set and remove the yellow hose from the vacuum pump that goes to the manifold gauge set.

Remove the vacuum pump and thermistor vacuum gauge.

CONDENSER

Removal And Installation

Figure 80-60-1

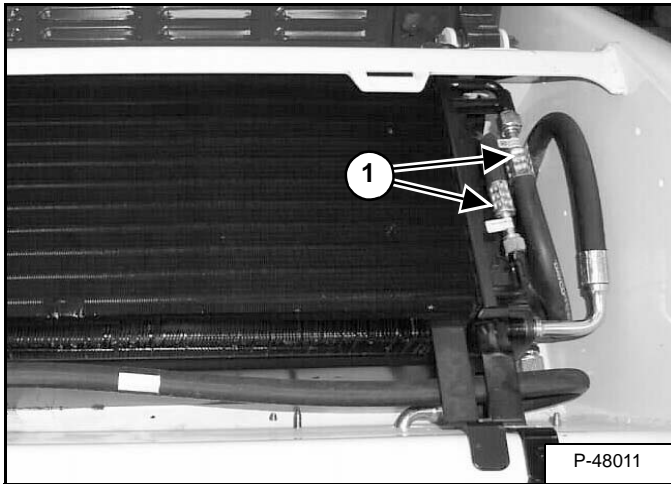

Remove the refrigerant from the A/C system. (See Reclamation And Charging With Recovery / Charging Unit on Page 80-40-2.)

Open the rear door of the loader.

Open the rear grille on the loader.

Mark the two A/C hoses (Item 1) [Figure 80-60-1] for proper installation.

WARNING

In the event of a leak, wear safety goggles. Escaping refrigerant can cause severe injuries to eyes. In contact with a flame, R134a refrigerant gives a toxic gas.

W-2371-0500

Disconnect the two hoses from the condenser (Item 1) [Figure 80-60-1].

Cap and plug the hoses and the condenser fittings with the proper A/C caps and plugs.

Figure 80-60-2

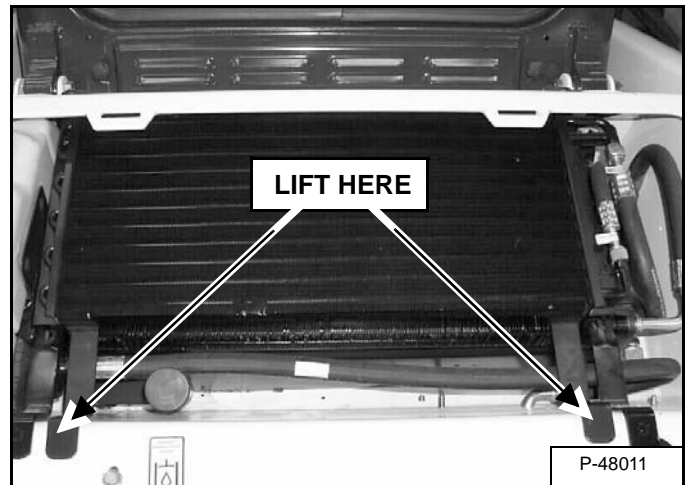

Lift the rear of the condenser [Figure 80-60-2], and pull toward the rear of the loader until the front tabs (Item 1) [Figure 80-60-4] slide out of bracket (Item 2) [Figure 80-60-4]

Figure 80-60-3



Remove the condenser from the loader [Figure 80-60-3].

EXPANSION VALVE

Removal And Installation

Figure 80-100-1

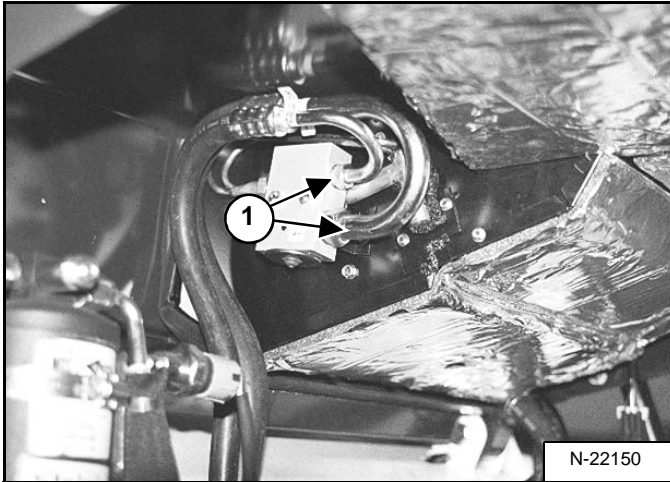

NOTE: The expansion valve can be changed without removing the evaporator / heater unit from the loader.

Raise the lift arms and install an approved lift arm support device. (See Installing on Page 10-20-1.)

Raise the operator cab. (See Raising on Page 10-30-1.)

Evacuate the A/C system. (See SYSTEM CHARGING AND RECLAMATION on Page 80-40-1.)

WARNING

In the event of a leak, wear safety goggles. Escaping refrigerant can cause severe injuries to eyes. In contact with a flame, R134a refrigerant gives a toxic gas.

W-2371-0500

Remove the two A/C hoses (Item 1) [Figure 80-100-1] from the expansion valve.

Installation: Tighten the two A/C hose fittings to 29,8 N•m (22 ft-lb) torque.

Cap and plug the hoses and the expansion valve fittings with the proper A/C caps and plugs.

Figure 80-100-2

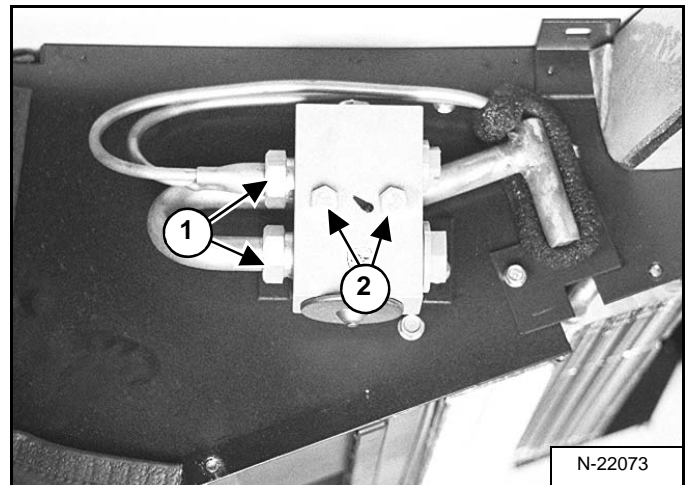

Remove the two evaporator fittings (Item 1) [Figure 80-100-2] from the expansion valve.

Installation: Tighten the two evaporator fittings to 29,8 N•m (22 ft-lb) torque.

Remove the two mount bolts (Item 2) [Figure 80-100-2].

Remove the expansion valve from the loader.

Figure 80-100-3

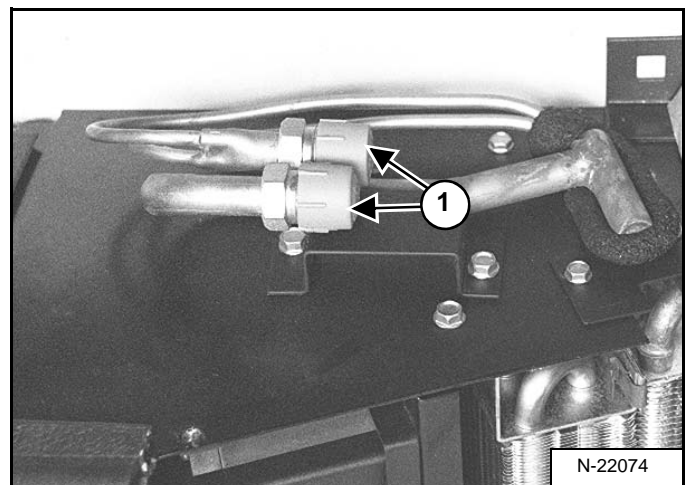

Cap and plug the evaporator tubelines (Item 1) [Figure 80-100-3] and the expansion valve fittings with the proper A/C caps and plugs.

BLOWER FAN (CONT'D)

Disassembly And Assembly (Cont'd)

Figure 80-130-9

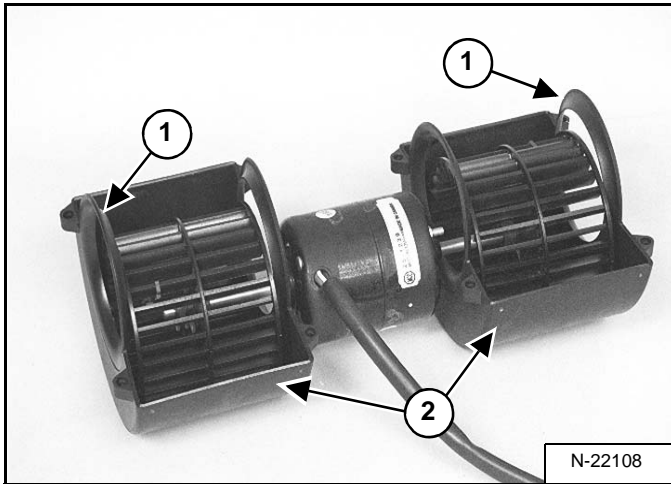

Remove the outside rings (Item 1) and blower wheel covers (Item 2) [Figure 80-130-9] from the blower motor and blower wheels.

Figure 80-130-10

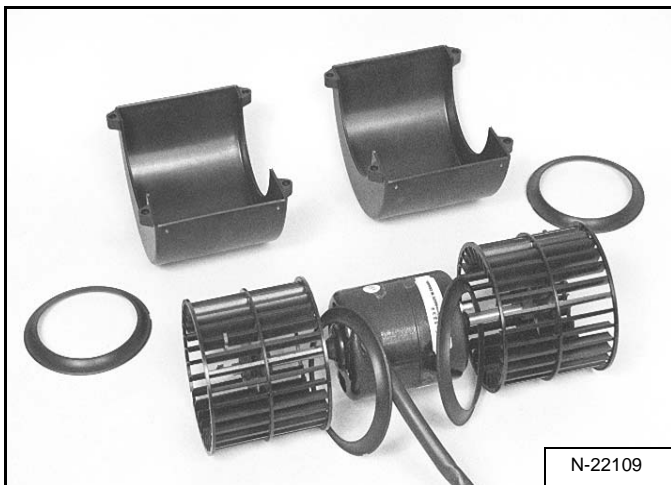

Inspect the end rings and blower wheel covers for wear and replace as needed [Figure 80-130-10].

Figure 80-130-11

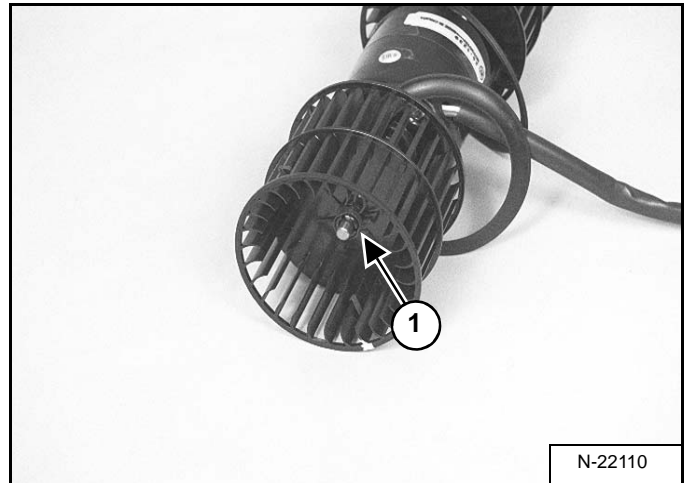
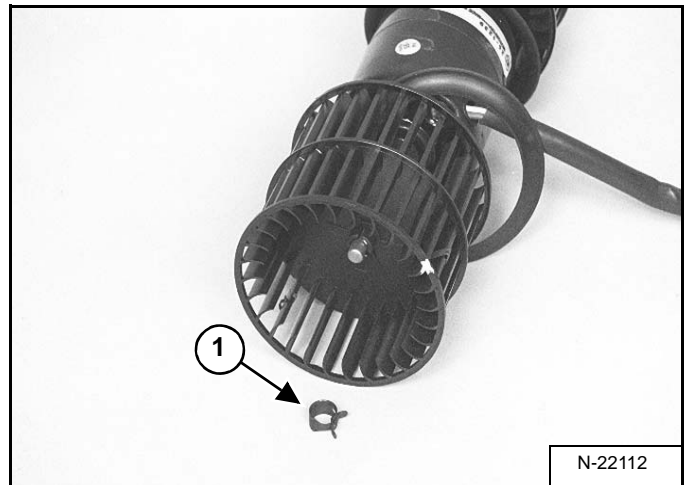

Figure 80-130-12



Remove the outside blower wheel clamp (Item 1) [Figure 80-130-11] and [Figure 80-130-12] from the blower wheel.

TORQUE SPECIFICATIONS FOR BOLTS

Torque For General SAE Bolts

The following table shows standard torque specifications for bolts with zinc phosphate coating. Bolts purchased from Bobcat Company that have zinc phosphate coating are specified by the letter H following the part number.

	Thread Size	SAE Grade 5	SAE Grade 8
N•m (in-lb)	0.250	9,0 - 10,2 (80 - 90)	12,4 - 13,6 (110 - 120)
	0.3125	20,3 - 22,6 (180 - 200)	24,2 - 27-1 (215 - 240)
N•m (ft-lb)	0.375	34 - 38 (25 - 28)	47 - 54 (35 - 40)
	0.4375	54 - 61 (40 - 45)	81 - 88 (60 - 65)
	0.500	88 - 95 (65 - 70)	122 - 136 (90 -100)
	0.5625	122 - 136 (90 - 100)	170 - 190 (125 - 140)
	0.625	170 - 190 (125 - 140)	240 - 260 (175 - 190)
	0.750	300 - 330 (220 - 245)	410 - 450 (300 - 330)
	0.875	450 - 490 (330 - 360)	645 - 710 (475 - 525)
	1.000	645 - 710 (475 - 525)	985 - 1085 (725 - 800)
	1.125	880 - 975 (650 - 720)	1425 - 1600 (1050 - 1175)
	1.250	1200 - 1360 (900 - 1000)	2000 - 2200 (1475 - 1625)
	1.375	1630 - 1830 (1200 - 1350)	2720 - 2980 (2000 - 2200)
	1.500	2040 - 2240 (1500 - 1650)	3530 - 3870 (2600 - 2850)
	1.625	2720 - 2980 (2000 - 2800)	4680 - 5150 (3450 - 3800)
	1.750	3390 - 3730 (2500 - 2750)	5830 - 6500 (4300 - 4800)
	1.875	4270 - 4750 (3150 - 3500)	7450 - 8300 (5500 - 6100)
2.000	5150 - 5700 (3800 - 4200)	8800 - 9800 (6500 - 7200)	

ALPHABETICAL INDEX

(S185) LOADER SPECIFICATIONS	SPEC-10-1
ACCESS PANEL (INSIDE) (SJC) . . .	50-121-1
ACCESS PANEL (INSIDE)	50-120-1
AIR CLEANER SERVICE	10-80-1
AIR CLEANER	70-40-1
AIR CONDITIONING SYSTEM FLOW .	80-10-1
ALTERNATOR	60-30-1
BACK-UP ALARM SYSTEM	60-210-1
BATTERY	60-20-1
BLOWER FAN	80-130-1
BOBCAT CONTROLLER (ACS)	60-71-1
BOBCAT CONTROLLER (GATEWAY AND AUXILIARY)	60-70-1
BOBCAT CONTROLLER (SJC) (DRIVE)	60-72-1
BOBCAT INTERLOCK CONTROL SYSTEM (BICS™)	60-100-1
BOB-TACH (HAND LEVER)	10-140-1
BOB-TACH (HAND LEVER)	50-40-1
BOB-TACH (POWER) BLOCK	20-130-1
BOB-TACH (POWER)	10-141-1
BOB-TACH (POWER)	50-41-1
BRAKE (SINGLE SPEED)	40-10-1
BRAKE (TWO-SPEED)	40-11-1
BUCKET POSITION VALVE	20-110-1
CAB DOOR	50-140-1
CALIBRATION	60-160-1
CAMSHAFT AND TIMING GEARS . .	70-100-1
CASE DRAIN FILTER	30-80-1
CHAINCASE	40-30-1
CHARGE PRESSURE	30-40-1
COMPRESSOR	80-50-1
CONDENSER	80-60-1
CONTROL HANDLE / LEVER (ACS) .	50-111-1
CONTROL HANDLE / LEVER (SJC) .	50-112-1
CONTROL HANDLE / LEVER	50-110-1
CONTROL PANEL (SJC)	50-101-1
CONTROL PANEL SETUP	60-180-1
CONTROL PANEL	50-100-1
CONTROL PEDALS (ACS)	50-91-1
CONTROL PEDALS AND LINKAGES .	50-90-1
CONTROL SYSTEM (ACS)	60-130-1
CONVERSIONS	SPEC-50-1
CRANKSHAFT AND PISTONS	70-90-1
CYLINDER (BOB-TACH)	20-22-1
CYLINDER (LIFT)	20-20-1
CYLINDER (TILT)	20-21-1
CYLINDER HEAD	70-80-1
DELIVERY REPORT	1-15
DIAGNOSTIC SERVICE CODES	60-90-1
DRIVE BELT	30-60-1
DRIVE COMPONENTS	40-20-1
ELECTRICAL / HYDRAULIC CONTROLS (ACS)	60-141-1
ELECTRICAL / HYDRAULIC CONTROLS (SJC)	60-142-1
ELECTRICAL / HYDRAULIC CONTROLS	60-140-1
ELECTRICAL SYSTEM INFORMATION	60-10-1
EMERGENCY EXIT	10-210-1
ENGINE COOLING SYSTEM	10-90-1
ENGINE COOLING SYSTEM	70-50-1
ENGINE INFORMATION	70-10-1
ENGINE LUBRICATION SYSTEM . . .	10-110-1
ENGINE SPEED CONTROL (SJC) . . .	70-21-1
ENGINE SPEED CONTROL	70-20-1
EVAPORATOR / HEATER UNIT	80-80-1
EVAPORATOR COIL	80-110-1
EXHAUST GAS RECIRCULATION (EGR) SYSTEM	70-130-1
EXPANSION VALVE	80-100-1
FINAL DRIVE TRANSMISSION (CHAINCASE)	10-130-1
FIRE PREVENTION	1-12
FLYWHEEL AND HOUSING	70-120-1
FLYWHEEL RPM SENSOR	60-170-1
FOREWORD	1-7
FRONT AUXILIARY HYDRAULIC COUPLER BLOCK	20-140-1
FUEL SYSTEM	10-100-1
FUEL SYSTEM	70-70-1
FUEL TANK	50-80-1
HEATER COIL	80-120-1
HEATER VALVE	80-140-1
HIGH FLOW VALVE	20-150-1



SERVICE MANUAL REVISION

ROUTE TO ATTENTION

PARTS MANAGER	<input type="checkbox"/>
SERVICE MANAGER	<input checked="" type="checkbox"/>
SALES MANAGER	<input type="checkbox"/>

NOTICE

Insert This Sheet With The Below Listed Manual For Future Reference.

Revision No: S185 - 4
Date: 17 October 2008
Product: Bobcat Loader
Model: S185
Manual No: 6987049 (10-08)

The following Sections are a revision to the above Service Manual.

COVER
10-200
20-01
20-40
20-41
50-01
50-130
60-01
ELECTRICAL SCHEMATICS
60-70
60-72
70-01
70-50

CLICK HERE TO **DOWNLOAD** THE COMPLETE MANUAL

- Thank you very much for reading the preview of the manual.
- You can download the complete manual from: www.heydownloads.com by clicking the link below



- Please note: If there is no response to CLICKING the link, please download this PDF first and then click on it.

CLICK HERE TO **DOWNLOAD** THE COMPLETE MANUAL