



Bobcat®

Service Manual

S175/S185 Skid-Steer Loader

S/N 530111001 & Above
S/N 530211001 & Above
S/N A8NZ11001 - A8NZ59999
S/N A8M411001 - A8M459999
S/N A8NY11001 - A8NY59999
S/N 530311001 - 530359999
S/N 530411001 - 530459999
S/N ABRT11001 - ABRT59999

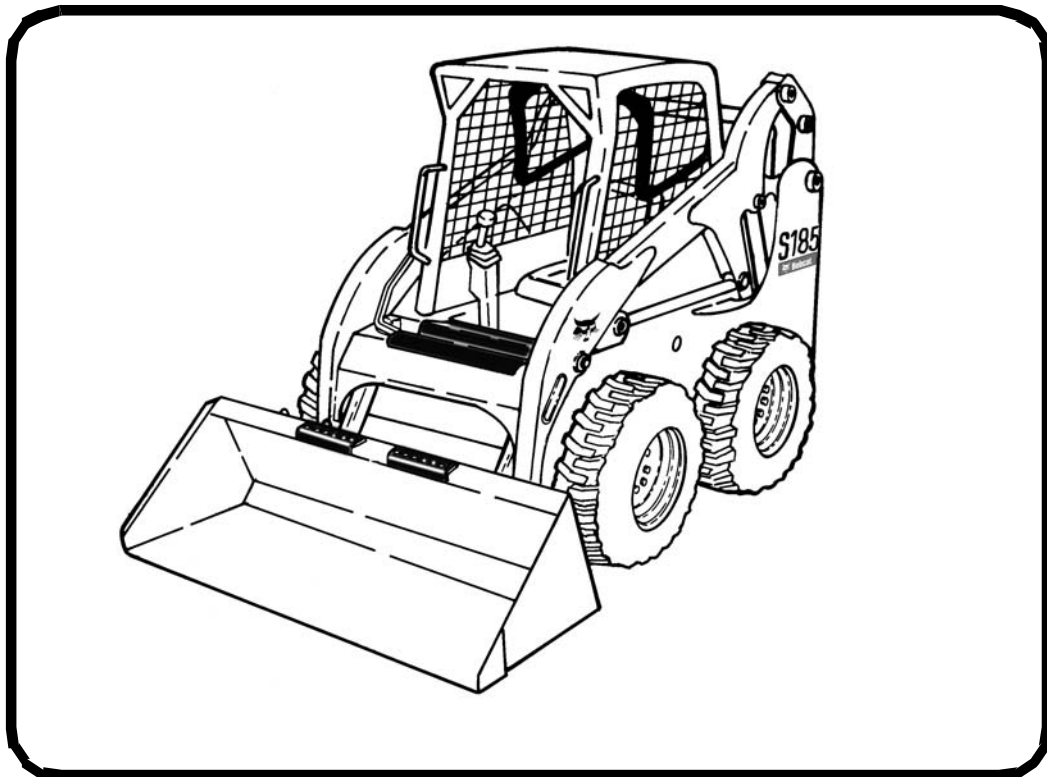

EQUIPPED WITH
BOBCAT INTERLOCK
CONTROL SYSTEM (BICS™)

6904132 (7-09)

Printed in U.S.A.



© Bobcat Company 2009

CLICK HERE TO **DOWNLOAD** THE COMPLETE MANUAL

- Thank you very much for reading the preview of the manual.
- You can download the complete manual from: www.heydownloads.com by clicking the link below



- Please note: If there is no response to CLICKING the link, please download this PDF first and then click on it.

CLICK HERE TO **DOWNLOAD** THE COMPLETE MANUAL

SAFETY INSTRUCTIONS



Safety Alert Symbol

This symbol with a warning statement means: **“Warning, be alert! Your safety is involved!”**
Carefully read the message that follows.



WARNING

Instructions are necessary before operating or servicing machine. Read and understand the Operation & Maintenance Manual, Operator's Handbook and signs (decals) on machine. Follow warnings and instructions in the manuals when making repairs, adjustments or servicing. Check for correct function after adjustments, repairs or service. Untrained operators and failure to follow instructions can cause injury or death.

W-2003-0903

IMPORTANT

This notice identifies procedures which must be followed to avoid damage to the machine.

I-2019-0284



DANGER

The signal word **DANGER** on the machine and in the manuals indicates a hazardous situation which, if not avoided, will result in death or serious injury.

D-1002-1107



WARNING

The signal word **WARNING** on the machine and in the manuals indicates a potentially hazardous situation which, if not avoided, could result in death or serious injury.

W-2044-1107

The following publications provide information on the safe use and maintenance of the Bobcat machine and attachments:

- The Delivery Report is used to assure that complete instructions have been given to the new owner and that the machine is in safe operating condition.
- The Operation & Maintenance Manual delivered with the machine or attachment contains operating information as well as routine maintenance and service procedures. It is a part of the machine and can be stored in a container provided on the machine. Replacement Operation & Maintenance Manuals can be ordered from your Bobcat dealer.
- Machine signs (decals) instruct on the safe operation and care of your Bobcat machine or attachment. The signs and their locations are shown in the Operation & Maintenance Manual. Replacement signs are available from your Bobcat dealer.
- An Operator's Handbook fastened to the operator cab. It's brief instructions are convenient to the operator. The handbook is available from your dealer in an English edition or one of many other languages. See your Bobcat dealer for more information on translated versions.
- The AEM Safety Manual delivered with the machine gives general safety information.
- The Service Manual and Parts Manual are available from your dealer for use by mechanics to do shop-type service and repair work.
- The Skid-Steer Loader Operator Training Course is available through your local dealer or at www.training.bobcat.com or www.bobcat.com. This course is intended to provide rules and practices of correct operation of the Skid-Steer Loader. The course is available in English and Spanish versions.
- Service Safety Training Courses are available from your Bobcat dealer or at www.training.bobcat.com or www.bobcat.com. They provide information for safe and correct service procedures.
- The Skid-Steer Loader Safety Video is available from your Bobcat dealer or at www.training.bobcat.com or www.bobcat.com.

SI SSL-1008 SM

SAFETY AND MAINTENANCE (CONT'D)

TIRE MAINTENANCE	10-160-1
Mounting	10-160-1
Rotating	10-160-1
Wheel Nuts	10-160-1
TOWING THE LOADER	10-50-1
Procedure	10-50-1
TRANSPORTING LOADER ON A TRAILER	10-40-1
Fastening	10-40-1
Loading And Unloading	10-40-1

TIGHTEN ALL HARDWARE PER SIZE TO GRADE 5 TORQUE (SEE STANDARD TORQUE SPECIFICATIONS FOR BOLTS, SECTION SPEC-01) UNLESS OTHERWISE SPECIFIED.

SPECIFICATIONS SUBJECT TO CHANGE WITHOUT NOTICE AND STANDARD ITEMS MAY VARY.

TRANSPORTING LOADER ON A TRAILER

Loading And Unloading



AVOID SERIOUS INJURY OR DEATH

Adequately designed ramps of sufficient strength are needed to support the weight of the machine when loading onto a transport vehicle. Wood ramps can break and cause personal injury.

W-2058-0807

Be sure the transport and towing vehicles are of adequate size and capacity. (See Capacities on Page SPEC-10-4.)

Figure 10-40-1

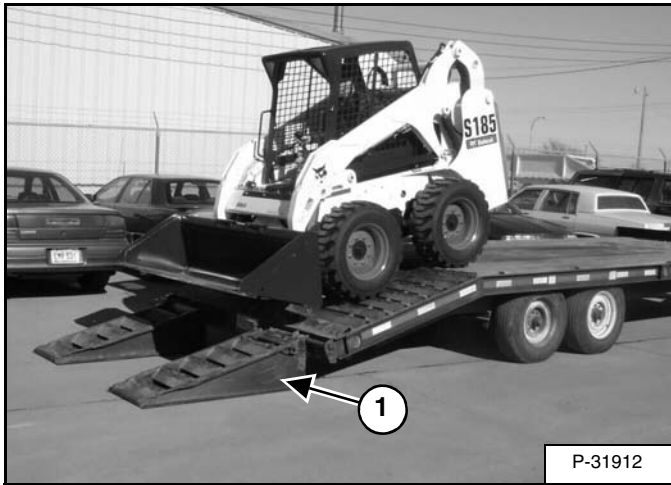

A loader with an empty bucket or no attachment must be loaded backward onto the transport vehicle [Figure 10-40-1].

The rear of the trailer must be blocked or supported (Item 1)[Figure 10-40-1] when loading or unloading the loader to prevent the front end of the trailer from raising up.

Fastening

Figure 10-40-2

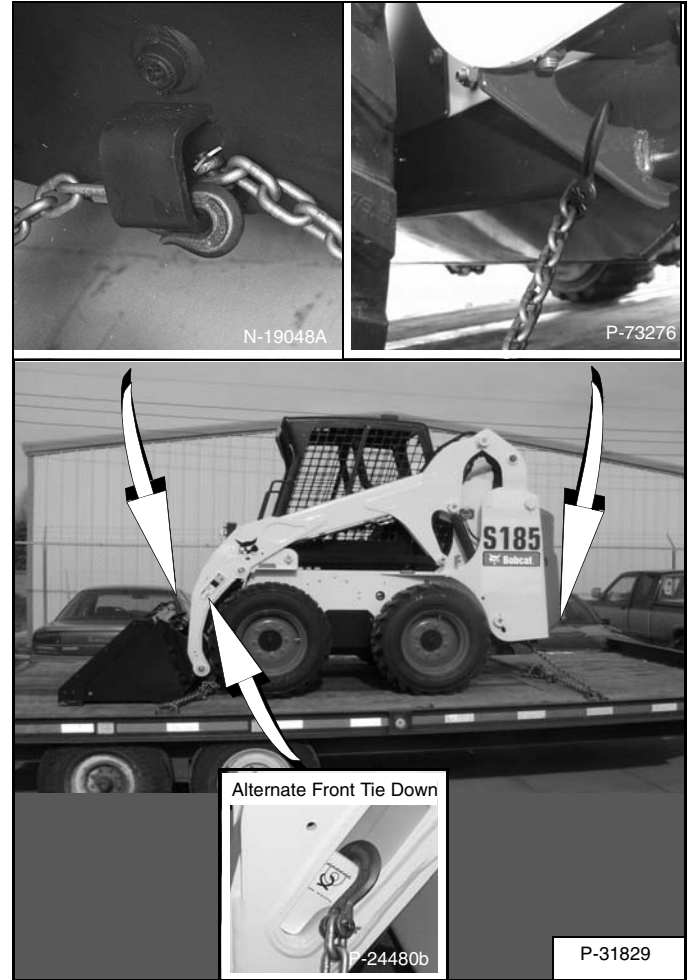

Use the following procedure to fasten the Bobcat loader to the transport vehicle to prevent the loader from moving during sudden stops or when going up or down slopes [Figure 10-40-2].

- Lower the bucket or attachment to the floor.
- Stop the engine.
- Engage the parking brake.
- Install chains at the front and rear loader tie down positions (Inset) [Figure 10-40-2].
- Fasten each end of the chain to the transport vehicle.

REMOTE START TOOL (SERVICE TOOL) KIT - 6689779

Description

The Remote Start Tool (Service Tool) Kit is a replacement tool for MEL 1563 Remote Start Tool and MEL 1400B - BOSS® Diagnostic Tool.

The Remote Start Tool (Service Tool) Kit, P/N 6689779, can be used to service older loaders with the BOSS® system using the supplied BOSS® Service Tool Harness P/N 6689745.

The Remote Start Tool (Service Tool) Kit, P/N 6689779, can be used to service newer loaders using the supplied harness P/N 6689747.

A computer can be connected to the Remote Start Tool (Service Tool) for diagnostics and software updates using the computer harness P/N 6689746 in conjunction with the loader harness.

AIR CLEANER SERVICE

Replacing Filter Elements

Figure 10-80-1

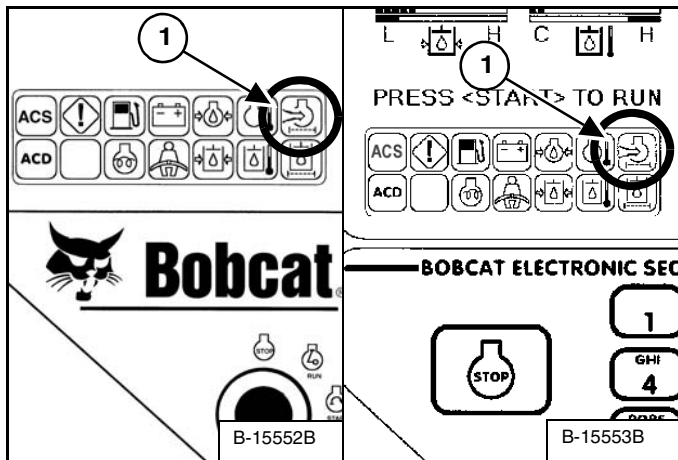

It is important to change the air filter element only when the Air Cleaner Icon in the right panel is ON (Item 1) [Figure 10-80-1] and you hear three beeps from the alarm.

Replace the inner filter every third time the outer filter is replaced or as indicated.

Figure 10-80-2

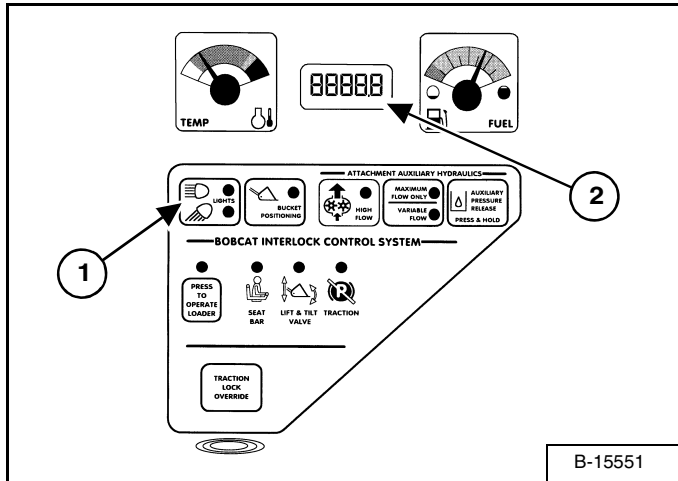

Press and hold the LIGHT Button (Item 1) [Figure 10-80-2] for two seconds.

If the filter element needs replacement, the CODE [01-17] (Air Filter Plugged) will show in the HOURMETER / CODE DISPLAY (Item 2) [Figure 10-80-2].

Outer Filter

Figure 10-80-3



Remove the wing nut and remove the dust cover [Figure 10-80-3].

Figure 10-80-4

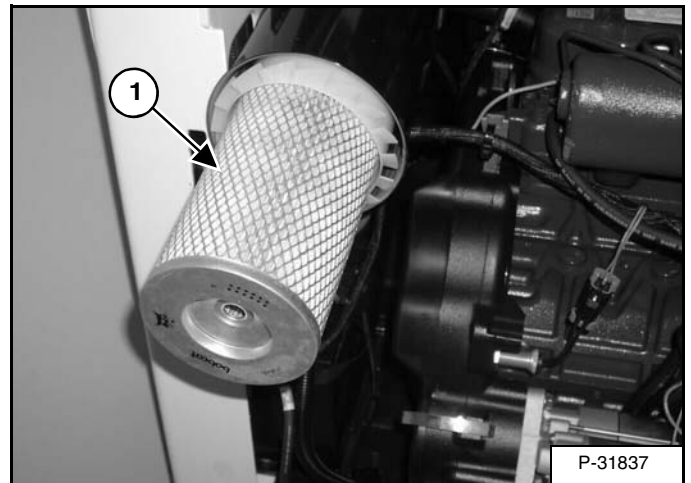

Remove the wing nut and remove the outer filter element (Item 1) [Figure 10-80-4].

NOTE: Make sure all sealing surfaces are free of dirt and debris. Do not use air pressure to clean.

Install a new outer element.

Install the dust cover and the wing nut [Figure 10-80-3] (Be sure the evacuator is down).

Check the air intake hose and the air cleaner housing for damage. Make sure all connections are tight.

ENGINE LUBRICATION SYSTEM

Checking And Adding Engine Oil

Check the engine oil level every day before starting the engine for the work shift.

Figure 10-110-1

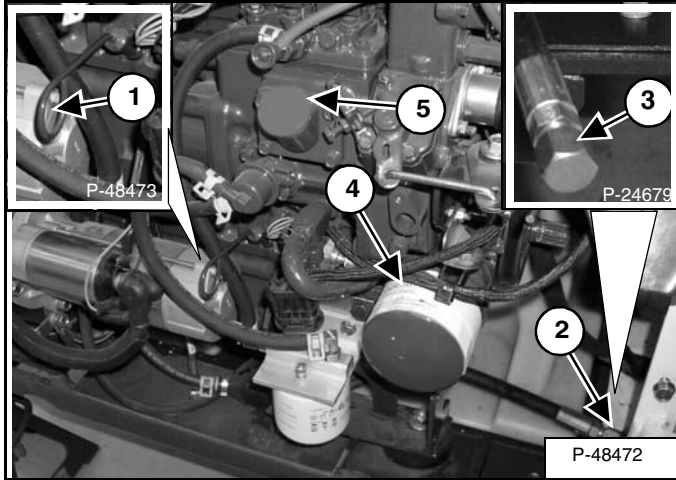

Open the rear door and remove the dipstick (Item 1) [Figure 10-110-1].

Keep the oil level between the marks on the dipstick. Do not overfill.

Engine Oil Chart

Figure 10-110-2

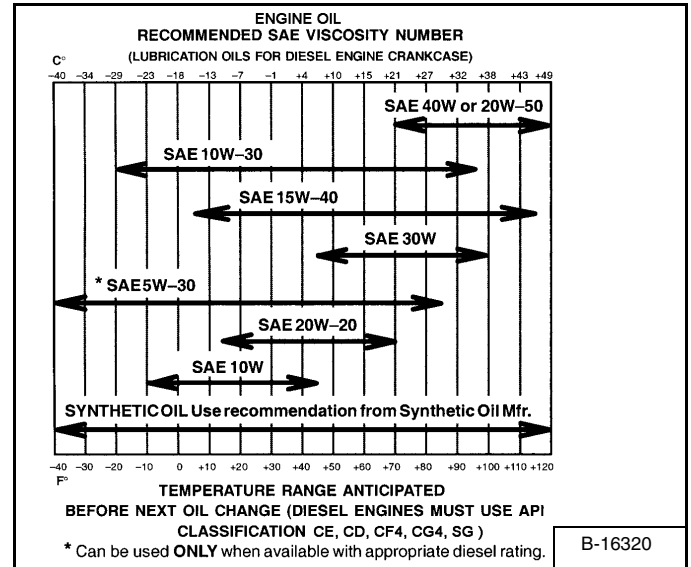

Use a good quality motor oil that meets API Service Classification of CD or better See Oil Chart [Figure 10-110-2].

Install the dipstick and close the rear door.

FINAL DRIVE TRANSMISSION (CHAINCASE)

Checking And Adding Oil

The chaincase contains the final drive sprockets and chains. Use the same type of oil as the hydraulic/hydrostatic system. (See S175 LOADER SPECIFICATIONS on Page SPEC-10-1).

Stop the loader on a level surface.

Stop the engine.

Figure 10-130-1

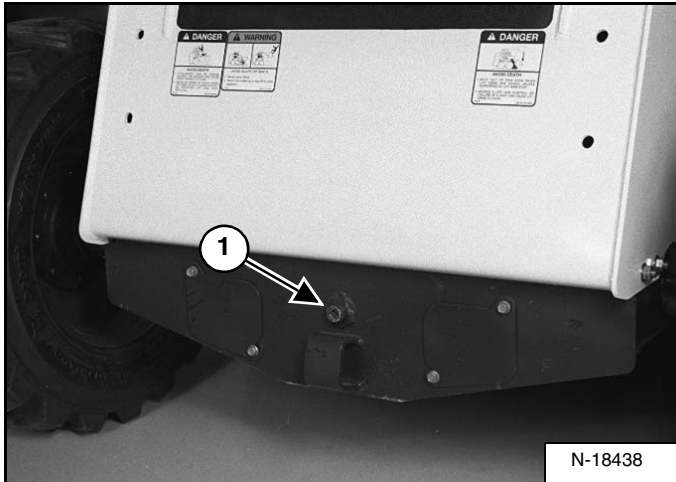

Remove the plug (Item 1) [Figure 10-130-1] from the front of the chaincase housing.

If oil can be reached with the tip of your finger through the hole, the oil level is correct.

If the level is low, add oil through the check plug hole until oil flows from the hole.

Install and tighten the plug.

Removing And Replacing Oil

Remove the check plug (Item 1) [Figure 10-130-1] from the front of the chaincase housing.

Figure 10-130-2



Remove the oil from the chaincase [Figure 10-130-2].

Recycle or dispose of the used oil in an environmentally safe manner.

SPARK ARRESTOR MUFFLER

Cleaning Procedure

See the SERVICE SCHEDULE for service interval for cleaning the spark arrestor muffler. (See SERVICE SCHEDULE on Page 10-70-1.)

Do not operate the loader with a defective exhaust system.

IMPORTANT

This loader is factory equipped with a U.S.D.A. Forestry Service approved spark arrestor muffler. It is necessary to do maintenance on this spark arrestor muffler to keep it in working condition. The spark arrestor muffler must be serviced by dumping the spark chamber every 100 hours of operation.

If this machine is operated on flammable forest, brush or grass covered land, it must be equipped with a spark arrestor attached to the exhaust system and maintained in working order. Failure to do so will be in violation of California State Law, Section 4442 PRC.

Consult local laws and regulations for spark arrestor requirements

I-2022-0807

Stop the engine. Open the rear door and raise the rear grill.

Figure 10-170-1

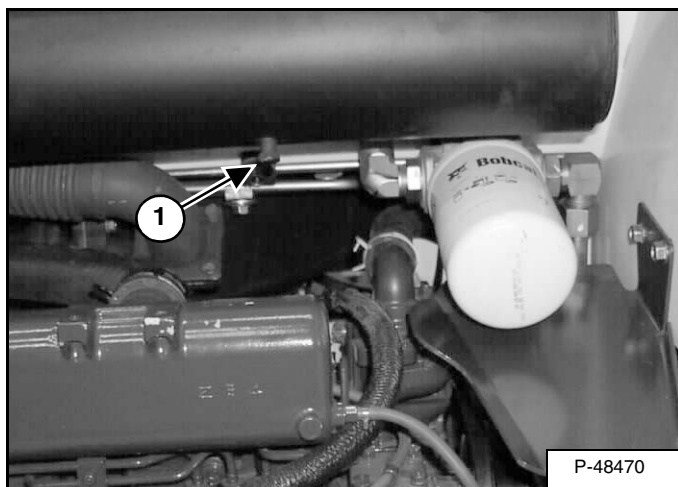

Remove the plug (Item 1) [Figure 10-170-1] from the bottom of the muffler.

! WARNING

When the engine is running during service, the steering levers must be in neutral and the parking brake engaged. Failure to do so can cause injury or death.

W-2006-0284

Start the engine and run for about 10 seconds while a second person, wearing safety glasses, holds a piece of wood over the outlet of the muffler.

This will force contaminants out through the cleanout hole.

Stop the engine.

Install and tighten the plug.

Lower the rear grill and close the rear door.

! WARNING

AVOID INJURY OR DEATH

When an engine is running in an enclosed area, fresh air must be added to avoid concentration of exhaust fumes. If the engine is stationary, vent the exhaust outside. Exhaust fumes contain odorless, invisible gases which can kill without warning.

W-2050-0807

! WARNING

Stop engine and allow the muffler to cool before cleaning the spark chamber. Wear safety goggles. Failure to obey can cause serious injury.

W-2011-1285

! WARNING

Never use machine in atmosphere with explosive dust or gases or where exhaust can contact flammable material. Failure to obey warnings can cause injury or death.

W-2068-1285

HYDRAULIC SYSTEM (CONT'D)

HYDRAULIC/HYDROSTATIC FILTERS	20-80-1
Description	20-80-1
Charge Filter Housing Removal And Installation	20-80-3
Housing Removal And Installation	20-80-1
HYDRAULIC FLUID RESERVOIR	20-90-1
Description	20-90-1
Hydraulic Fluid Screen	20-90-4
Removal And Installation	20-90-1
HYDRAULIC PUMP (STANDARD)	20-60-1
Description	20-60-1
Direct Pump Test (Charge Section)	20-60-4
Direct Pump Test (Standard Section)	20-60-2
Disassembly And Assembly	20-60-9
Hydraulic Pump Start Up	20-60-17
Parts Identification	20-60-8
Pump Test at Quick Couplers	20-60-1
Removal And Installation	20-60-6
HYDRAULIC PUMP (STANDARD) (HIGH FLOW)	20-61-1
Description	20-61-1
Direct Pump Test (Charge Section)	20-61-4
Direct Pump Test (High Flow Section)	20-61-6
Direct Pump Test (Standard Section)	20-61-2
Disassembly And Assembly	20-61-11
Hydraulic Pump Start Up	20-61-23
Parts Identification	20-61-10
Pump Test at Quick Couplers	20-61-1
Removal And Installation	20-61-8
HYDRAULIC PUMP (SJC)	20-70-1
Description	20-70-1
Direct Pump Test (Charge Section)	20-70-4
Direct Pump Test (Standard Section)	20-70-2
Disassembly And Assembly	20-70-9
Hydraulic Pump Start Up	20-70-17
Parts Identification	20-70-8
Pump Test at Quick Couplers	20-70-1
Removal And Installation	20-70-6

Continued On Next Page

HYDRAULIC/HYDROSTATIC SCHEMATIC WITH SJC OPTION

S175 (S/N 530111001 AND ABOVE)
(S/N 530211001 AND ABOVE)
(S/N A8M411001 - A8M459999)
(S/N A8NY11001 - A8NY59999)
(S/N A8NZ11001 - A8NZ59999)

S185 (S/N 530311001 - 530359999)
(S/N 530411001 - 530459999)
(S/N ABRT11001 - ABRT59999)

(PRINTED FEBRUARY 2008)
V-0739legend







LEGEND

- | | | | |
|--|---|--|--|
| <p>① RESERVOIR:
Capacity 19.2 qt. (18,2 L)</p> <p>② SPRING LOADED FILTER BY-PASS VALVE: 45-55 PSI (3,1-3,8 bar)</p> <p>③ DIFFERENTIAL PRESSURE SWITCH:
36-44 PSI (2,5-3,0 bar)
Normally Closed</p> <p>④ DRIVE MOTOR SHUTTLE VALVE</p> <p>⑤ RELIEF/REPLENISHING VALVE - HIGH PRESSURE: 5075 PSI (350 bar)</p> <p>⑥ RELIEF VALVE - CHARGE INLET:
360 PSI (24,8 bar)
at High Engine Idle
With 140 degrees F. (60 degrees C.) Fluid</p> <p>⑦ FRONT AUXILIARY MANUAL PRESSURE BLEED-OFF VALVE</p> <p>⑧ HYDRAULIC PUMP Gear Type
16.9 GPM (64 L/min.) at High Engine Idle</p> <p>⑨ RELIEF VALVE - MAIN:
3250-3350 PSI (224-231 bar)
at Front Quick Couplers</p> <p>⑩ PORT RELIEF/ANTICAVITATION VALVE
3500 PSI (241,3 bar)</p> <p>⑪ ANTICAVITATION VALVE</p> <p>⑫ SOLENOID ACTIVATED DIRECTIONAL CONTROL VALVE - AUXILIARY</p> <p>⑬ PORT RELIEF/ANTICAVITATION VALVE:
. (Optional)
3500 PSI (241,3 bar)</p> <p>⑭ LOAD CHECK VALVE</p> <p>⑮ LIFT CYLINDER SPOOL - MADE TO RESTRICT FLOW DURING BOOM DOWN BUT NOT DURING BOOM UP</p> | <p>⑯ SOLENOID ACTIVATED DIRECTIONAL CONTROL VALVE - BICS CONTROL</p> <p>⑰ PILOTED ACTIVATED DIRECTIONAL CONTROL VALVE - TILT CONTROL</p> <p>⑱ PILOTED ACTIVATED DIRECTIONAL CONTROL VALVE - LIFT CONTROL</p> <p>⑲ PULL BUTTON ACTIVATED DIRECTIONAL CONTROL VALVE - LIFT ARM BY-PASS</p> <p>⑳ PILOTED ACTIVATED DIRECTIONAL CONTROL VALVE - UNLOADING SPOOL</p> <p>㉑ PILOTED ACTIVATED DIRECTIONAL CONTROL VALVE - FLOW CONTROL SPOOL</p> <p>㉒ FLOW DIVIDER ADJUSTMENT VALVE</p> <p>㉓ SOLENOID ACTIVATED DIRECTIONAL CONTROL VALVE - BASE</p> <p>㉔ SOLENOID ACTIVATED DIRECTIONAL CONTROL VALVE - ROD</p> <p>㉕ LOAD SHUTTLE VALVE - BLEED OFF</p> <p>㉖ SOLENOID ACTIVATED DIRECTIONAL CONTROL VALVE - TWO COIL</p> <p>㉗ PILOT ACTIVATED DIRECTIONAL CONTROL VALVE - REAR AUXILIARY</p> <p>㉘ RESTRICTOR - 0.140 inch (3,6 mm)</p> <p>㉙ RESTRICTOR - 0.031 inch (0,8 mm)</p> <p>㉚ RELIEF VALVE: 3300 PSI (228 bar)</p> <p>㉛ FILTER - HYDRAULIC (CANISTER)</p> | <p>㉜ FILTER - CASE DRAIN (SINTERED BRONZE)</p> <p>㉝ FILTER - BICS CONTROL VALVE (SCREEN)</p> <p>㉞ CHECK VALVE - BUCKET POSITION VALVE</p> <p>㉟ RESTRICTION</p> <p>㊱ VARIABLE CAPACITY DISPLACEMENT BI-DIRECTIONAL HYDROSTATIC PUMP</p> <p>㊲ SHUTTLE RELIEF VALVE
(Not Adjustable - Factory Set)
65 PSI (4,5 bar)</p> <p>㊳ FIXED CAPACITY DISPLACEMENT BI-DIRECTIONAL HYDROSTATIC MOTOR</p> <p>㊴ CHECK VALVE - With 80 PSI (5,5 bar) Spring</p> <p>㊵ SOLENOID ACTIVATED DIRECTIONAL CONTROL VALVE - BUCKET POSITION VALVE (ON/OFF)</p> <p>㊶ CHECK VALVE - BICS CONTROL VALVE</p> <p>㊷ RESTRICTION - 0.343 inch (8,7 mm)</p> <p>㊸ FILTER - Bob-Tach Valve</p> <p>㊹ PILOT ACTIVATED DIRECTIONAL CONTROL VALVE - HYDRAULIC POWERED BOB-TACH</p> <p>㊺ RESTRICTION - 0.089 inch (2,26 mm)</p> <p>㊻ RESTRICTION - 0.025 inch (0,6 mm)</p> | <p>㊼ RELIEF VALVE - 2000 PSI (137 bar)</p> <p>㊽ RELIEF VALVE - 1200 PSI (83 bar)</p> <p>㊾ SOLENOID ACTIVATED DIRECTIONAL CONTROL VALVE (TWO COIL)</p> <p>㊿ FIXED CAPACITY DISPLACEMENT HYDRAULIC MOTOR</p> <p>51 ANTICAVITATION VALVE</p> <p>52 PROPORTIONAL RELIEF VALVE – (Fan Speed Regulator):
1566 - 1784 PSI (108 - 123 bar)</p> <p>53 CHARGE PUMP -
12.8 GPM (48,5 L/min) at High Engine Idle</p> <p>54 CHECK VALVE - With 300 PSI (20,7 bar) Spring with 0.016 inch (0,40 mm) orifice</p> <p>55 SOLENOID ACTIVATED CONTROL VALVE - FORWARD/REVERSE</p> <p>56 SERVO PISTON -Swash Plate</p> <p>57 POSITION SENSOR -Swash Plate</p> <p>58 CHARGE PRESSURE SENSOR</p> <p>59 SENSOR – CHARGE PRESSURE – Fan Filter</p> <p>60 SENSOR – HYD. TEMP. – Hyd. Filter</p> |
|--|---|--|--|

NOTE: Unless otherwise specified, springs have NO significant pressure value.

HYDRAULIC SYSTEM INFORMATION (CONT'D)

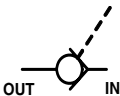
Glossary Of Hydraulic / Hydrostatic Symbols (Cont'd)

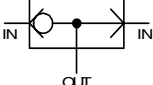
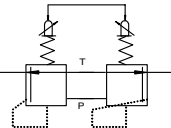
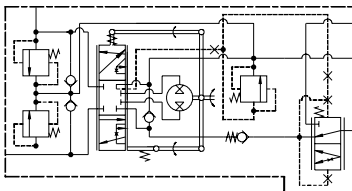
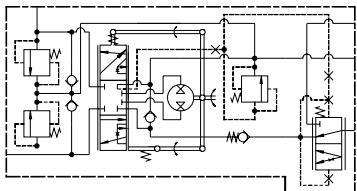
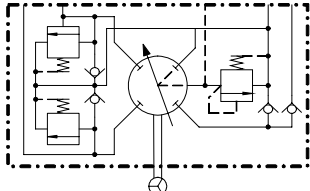
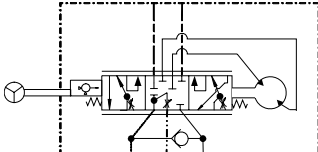
SYMBOL	DESCRIPTION	SYMBOL	DESCRIPTION
	<p>NON-RETURN VALVE (Check Valve) - Used as Replenishing Valve, Lock Check Valve or Anticavitation Valve - Opens if the Inlet pressure is higher than the Outlet pressure. Often contains internal spring which has NO significant pressure value.</p>		<p>TWO PORTS and CLOSED FLOW PATHS</p>
	<p>SPRING LOADED VALVE (bypass Valve) - Opens if the Inlet pressure is greater than the Outlet pressure plus the spring pressure.</p>		<p>SOLENOID ACTIVATED DIRECTIONAL CONTROL VALVE (Two Position) - controlled by an electric solenoid (with return spring).</p>
	<p>PILOT CONTROLLED NON-RETURN VALVE- It is possible to open the valve by pilot pressure.</p>		<p>PILOT ACTIVATED DIRECTIONAL CONTROL VALVE (Two Position) - controlled by pressure (with return spring).</p>
	<p>SHUTTLE VALVE - The Inlet port connected to the higher pressure is automatically connected to the Outlet port while the other Inlet port is closed.</p>		<p>MANUALLY ACTIVATED DIRECTION CONTROL VALVE (Variable Position) Joystick Controlled, variable pressure to shift the pilot activated directional control valve spool.</p>
	<p>STEERING CONTROL VALVE (Variable Position) - Used for controlling the hydraulic flow for the steering cylinders in relationship to the amount the steering wheel is rotated.</p>		<p>MANUALLY ACTIVATED FLOW CONTROL VALVE (Two Position) allows for changing pilot flow to control switching joystick functions for STD / ISO Control (Excavators Only).</p>
			
			

CYLINDER (LIFT) (CONT'D)

Disassembly and Assembly (Cont'd)

Figure 20-20-13

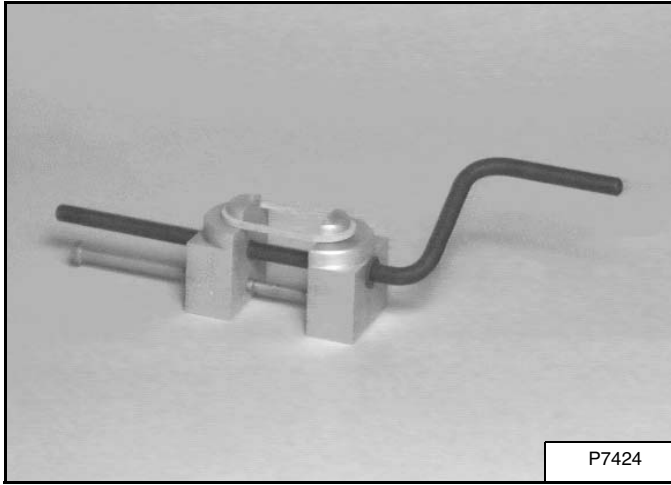

Assembly: Install the new seal on the tool and slowly stretch it until it fits the piston [Figure 20-20-13]. Allow the seal to stretch for 30 seconds before installing it on the piston.

Once the seal is installed on the piston, a piston ring compressor can be used on the piston for 3 minutes to compress the seal into place.

Figure 20-20-14

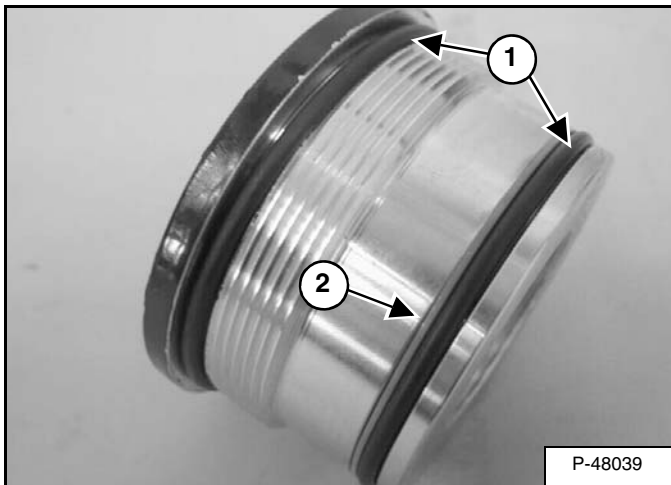

Remove the two O-rings (Item 1) and the back-up washer (Item 2) [Figure 20-20-14] from the cylinder head.

Figure 20-20-15

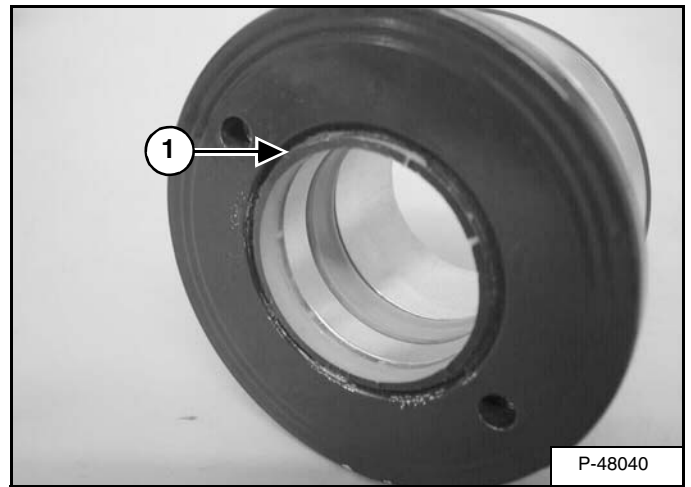

Remove the wiper seal (Item 1) [Figure 20-20-15] from the cylinder head.

Figure 20-20-16

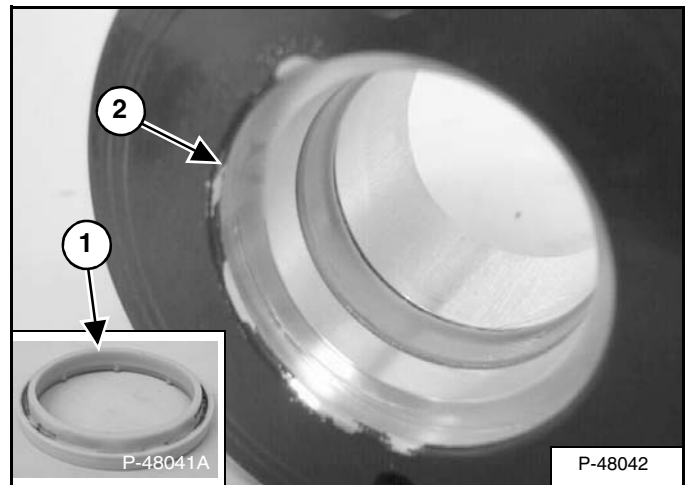

Install the wiper seal, with the wiper side of the seal (Item 1), toward the outside of the head (Item 2) [Figure 20-20-16].

CYLINDER (BOB-TACH)

Testing

! WARNING

AVOID INJURY OR DEATH

Always clean up spilled fuel or oil. Keep heat, flames, sparks or lighted tobacco away from fuel and oil. Failure to use care around combustibles can cause explosion or fire.

W-2103-0508

! WARNING

AVOID INJURY OR DEATH

Diesel fuel or hydraulic fluid under pressure can penetrate skin or eyes, causing serious injury or death. Fluid leaks under pressure may not be visible. Use a piece of cardboard or wood to find leaks. Do not use your bare hand. Wear safety goggles. If fluid enters skin or eyes, get immediate medical attention from a physician familiar with this injury.

W-2072-0807

Figure 20-22-1

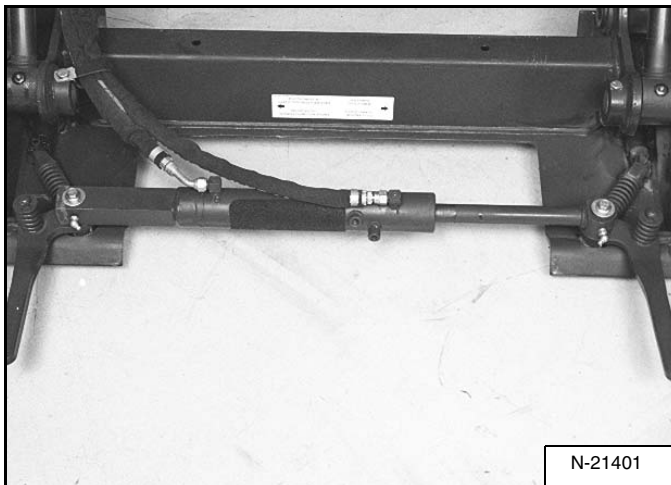

Tilt the Bob-Tach forward, so it is parallel to the floor [Figure 20-22-1].

Figure 20-22-2

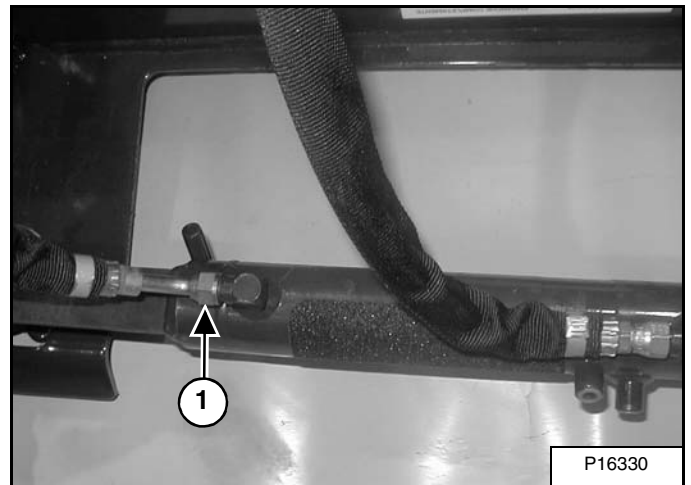

Disconnect the hose (Item 1) [Figure 20-22-2] from the Bob-Tach cylinder base end port.

Figure 20-22-3

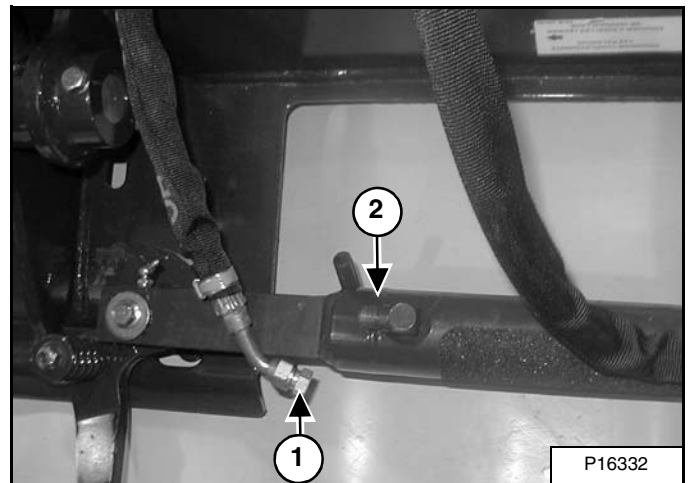

Install a plug in the hose (Item 1) [Figure 20-22-3] and tighten.

Engage the parking brake. Lower the seat bar. Start the engine.

Push and hold the BOB-TACH “WEDGES UP” Switch (Front Accessory Panel).

If there is any leakage from the base end cylinder port (Item 2) [Figure 20-22-3], remove the Bob-Tach cylinder for repair.

HYDRAULIC CONTROL VALVE (STANDARD)

Description

Figure 20-40-1

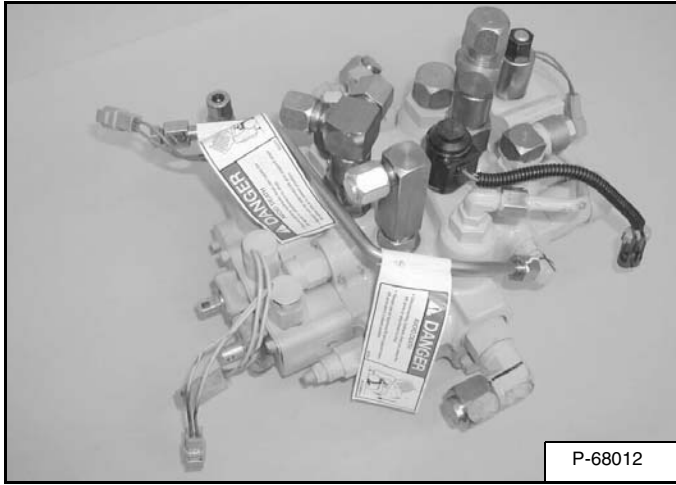

The hydraulic control valve is located inside the main frame on the right hand side, below the operators cab.

The hydraulic control valve [Figure 20-40-1] is the hydraulic component that uses spools to direct the flow of hydraulic fluid to the lift, tilt and auxiliary functions.

The lift and tilt functions are operated using mechanical linkages to connect the foot pedals to the lift and tilt spools.

The auxiliary function is operated by pilot pressure. There is one solenoid located by each side of the spool. Only one solenoid at a time is activated by the switch on the right side control handle/lever. The activated solenoid sends pilot pressure oil to one side of the spool and forces the spool to shift.

The hydraulic control valve contains a main relief valve which is adjustable.

Removal And Installation

DANGER



P-90328

AVOID DEATH

- Disconnecting or loosening any hydraulic tubeline, hose, fitting, component or a part failure can cause lift arms to drop.
- Keep out of this area when lift arms are raised unless supported by an approved lift arm support. Replace if damaged.

D-1009-0409

WARNING

Never work on a machine with the lift arms up unless the lift arms are secured by an approved lift arm support device. Failure to use an approved lift arm support device can allow the lift arms or attachment to fall and cause injury or death.

W-2059-0598

IMPORTANT

When repairing hydrostatic and hydraulic systems, clean the work area before disassembly and keep all parts clean. Always use caps and plugs on hoses, tubelines and ports to keep dirt out. Dirt can quickly damage the system.

I-2003-0888

Lift and block the loader. (See Procedure on Page 10-10-1.)

Raise the lift arms and install an approved lift arm support device (See Installing on Page 10-20-1.)

Raise the operator cab. (See Raising on Page 10-30-2.)

HYDRAULIC CONTROL VALVE (STANDARD) (CONT'D)

Port Relief/Anti-Cavitation Valve Removal And Installation (Tilt, Rod End)

Figure 20-40-33

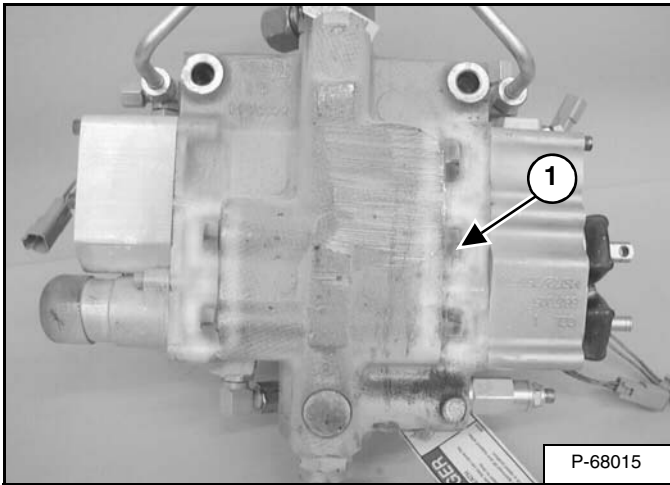

Remove the tilt port relief/anti cavitation valve (Item 1) [Figure 20-40-33] from the rod end of the tilt section.

Figure 20-40-34

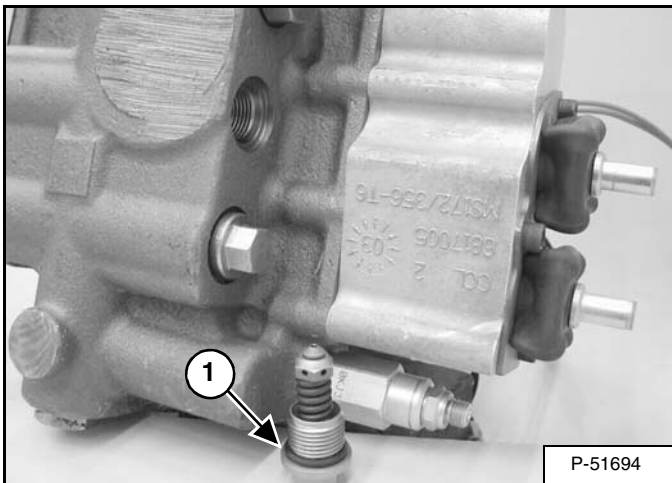

Replace the O-ring (Item 1) [Figure 20-40-34] before installation.

Installation: Tighten to 38 - 45 ft.-lb. (52 - 61 N•m) torque.

Port Relief Valve Removal And Installation

Figure 20-40-35

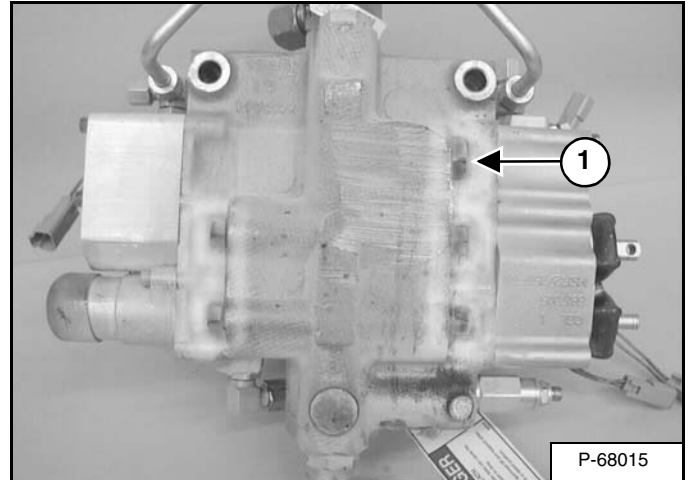

Remove the port relief plug (Item 1) [Figure 20-40-35] from the auxiliary circuit of the control valve.

Figure 20-40-36

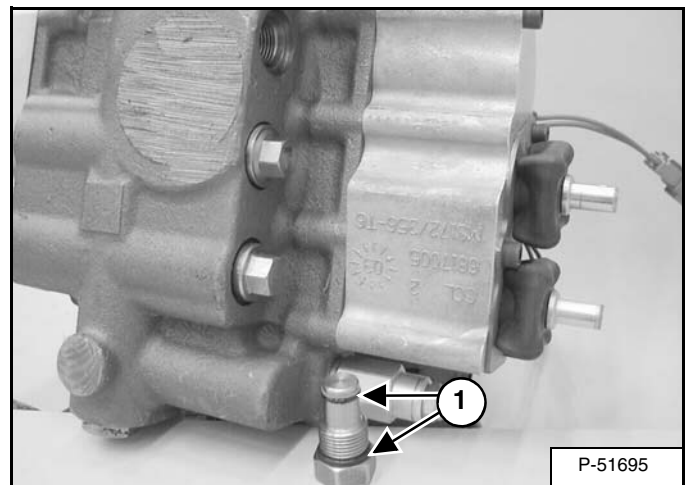

Installation: Always use new O-rings (Item 1) [Figure 20-40-36]. Tighten to 38 - 45 ft.-lb. (52 - 61 N•m) torque.

HYDRAULIC CONTROL VALVE (STANDARD) (CONT'D)

Lift Spool And Detent Removal And Installation (Cont'd)

Figure 20-40-72

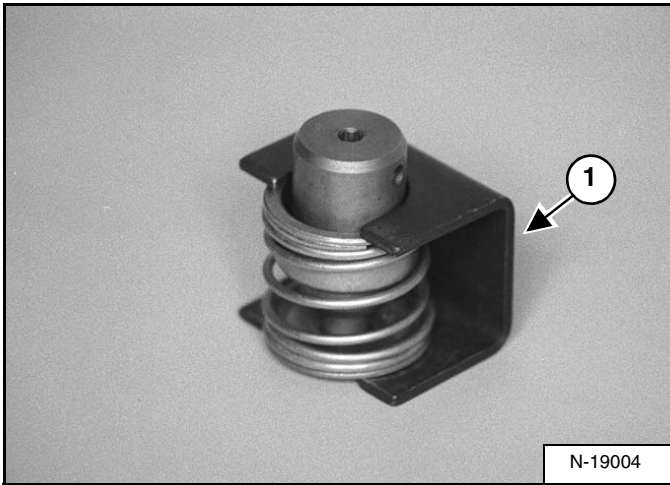

Install the spring tool (Item 1) [Figure 20-40-72] over the washer, spring, collar and detent adapter.

Figure 20-40-73

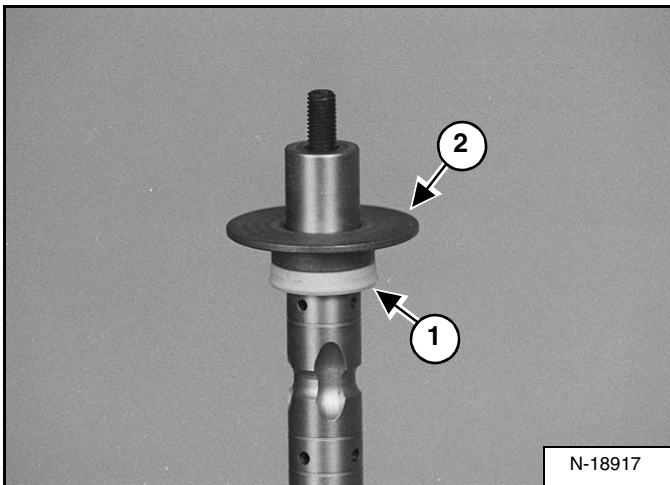

Install the spool seal (Item 1) and back-up washer (Item 2) [Figure 20-40-73].

Figure 20-40-74

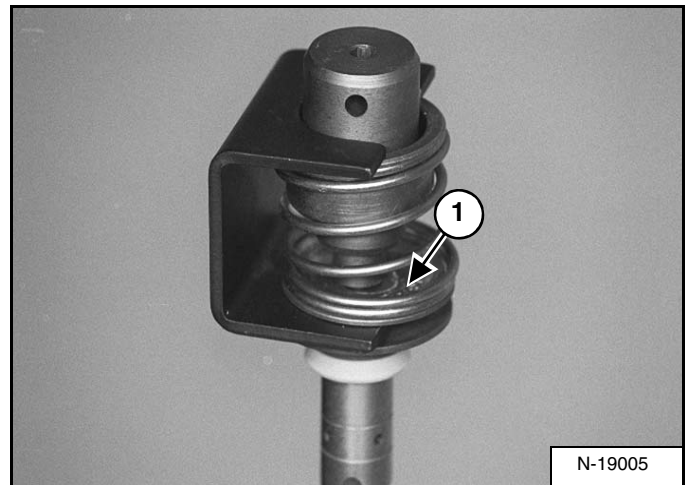

Install the spring assembly to the lift spool hand tight [Figure 20-40-74].

Remove the spring tool.

Check the alignment of the detent adapter and the washer.

Tighten the adapter to 90 - 100 in.-lb. (10 - 11,3 N•m).

NOTE: The adapter must fit in the center of the washer (Item 1) [Figure 20-40-74].

Figure 20-40-75



Install the detent balls and spring [Figure 20-40-75].

HYDRAULIC CONTROL VALVE (STANDARD) (CONT'D)

Lock Valve Removal And Installation

Figure 20-40-109

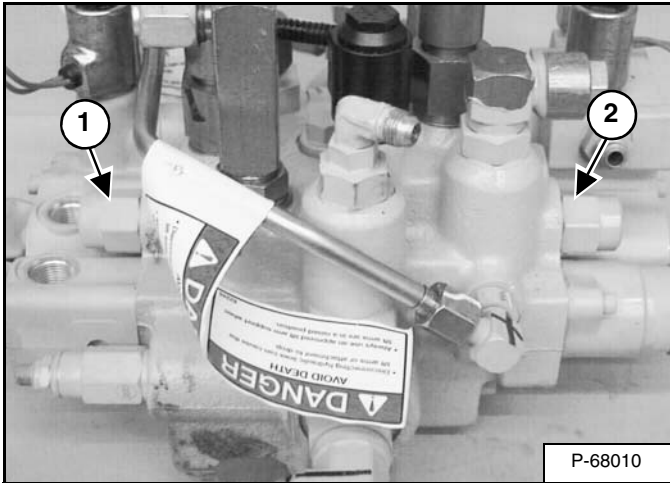

Locate the two BICS lock valves, (Item 1) is for the tilt circuit and (Item 2) [Figure 20-40-109] is for the lift circuit.

Figure 20-40-110

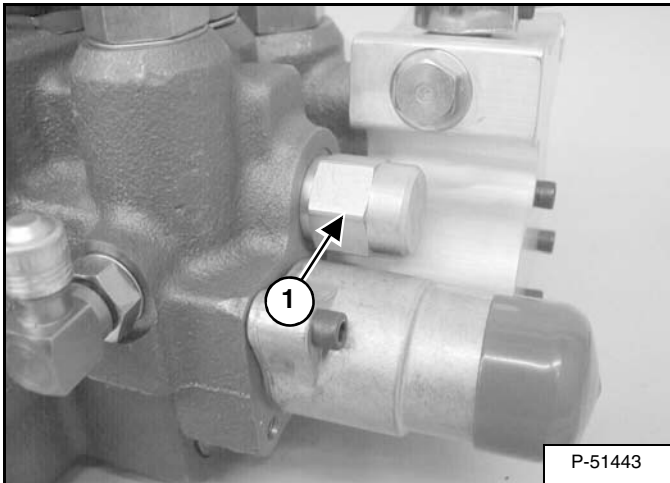

Remove the lift lock valve (Item 1) [Figure 20-40-110] from the back of the control valve.

Installation: Lightly lubricate the lock valve O-rings and tighten to 20 - 24 ft.-lb. (27 - 33 N•m) torque.

Figure 20-40-111

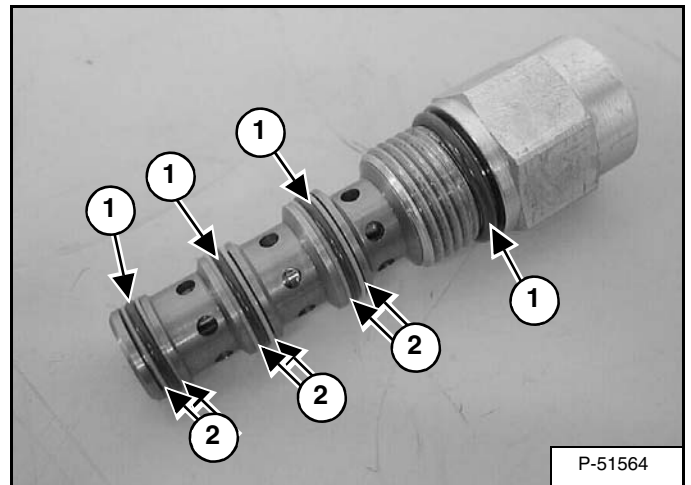

Remove the O-rings (Item 1) and back-up rings (Item 2) [Figure 20-40-111] from the lift lock valve, and replace with new.

HYDRAULIC CONTROL VALVE (ACS) OR (SJC) (CONT'D)

Actuator Removal And Installation (Out of Loader) (Cont'd)

Figure 20-41-21

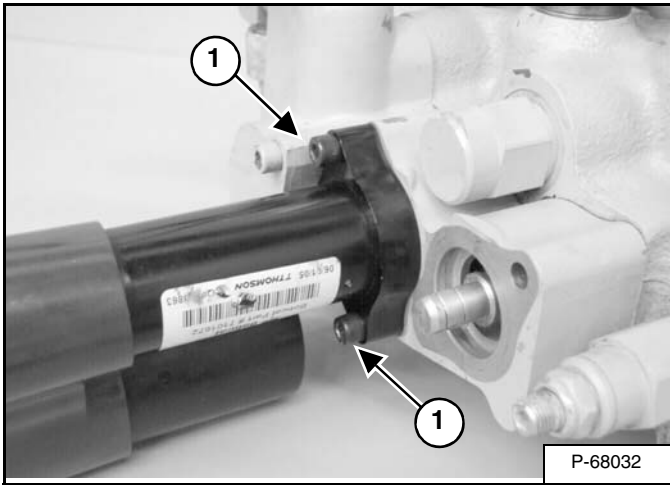

Remove the two mount bolts (Item 1) [Figure 20-41-21] from the tilt actuator.

Installation: Tighten the mounting bolts to 90 - 100 in.-lb. (10 - 11,3 N•m) torque.

Figure 20-41-22

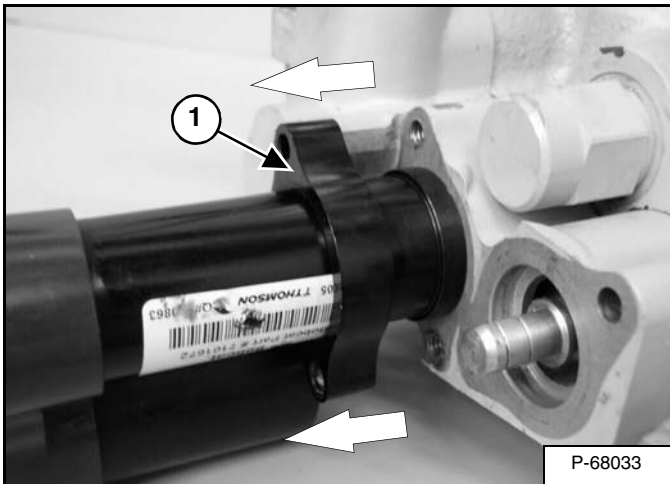

Slide the actuator mount bracket (Item 1) [Figure 20-41-22] away from the control valve.

Pull the actuator away from the control valve [Figure 20-41-22].

Figure 20-41-23

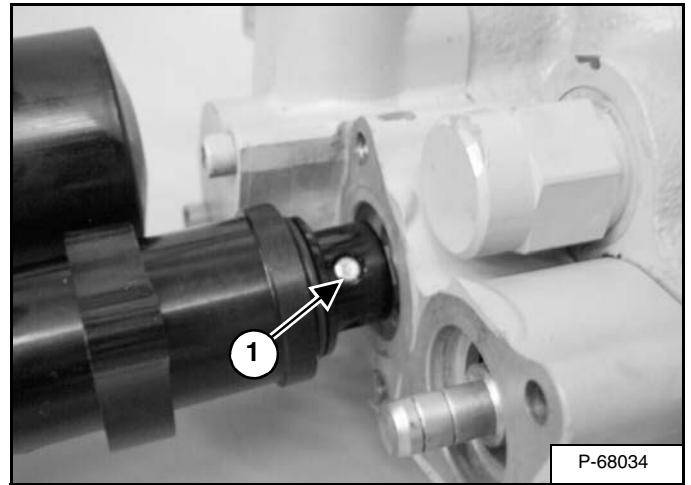

Using a drift pin and a hammer, remove the actuator linkage pin (Item 1) [Figure 20-41-23] from the actuator and the tilt spool.

Remove the actuator and linkage pin from the valve.

Figure 20-41-24

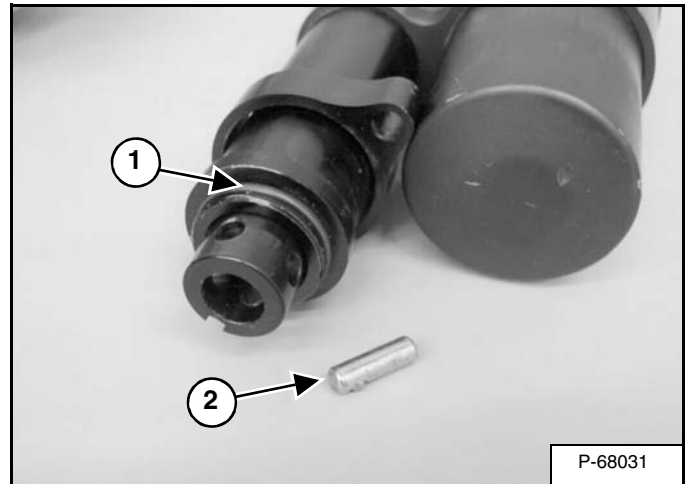

Inspect the O-ring (Item 1) [Figure 20-41-24] on the nose of the actuator, and replace as needed.

Check the linkage pin (Item 2) [Figure 20-41-24] and replace as needed.

HYDRAULIC CONTROL VALVE (ACS) OR (SJC) (CONT'D)

Lift Spool And Detent Removal And Installation

The tool listed will be needed to do the following procedure:

MEL 1285 - Spring Tool

Remove the end cap block from the control valve.

Figure 20-41-53

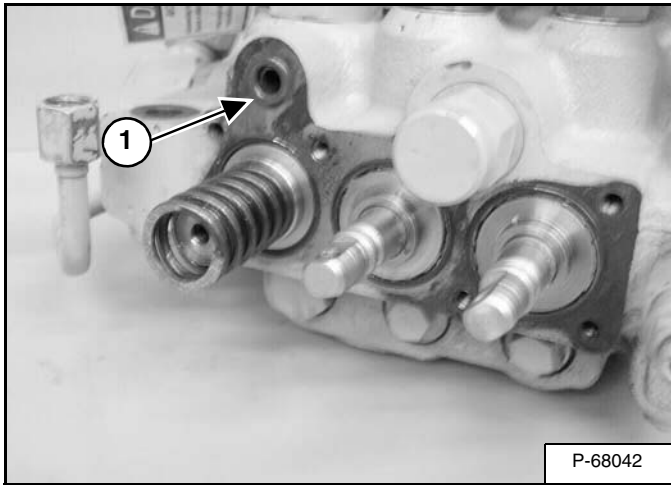

Remove the O-ring (Item 1) [Figure 20-41-53].

Installation: Replace the O-ring, and lubricate lightly with oil before installation of the end cap block.

Figure 20-41-54

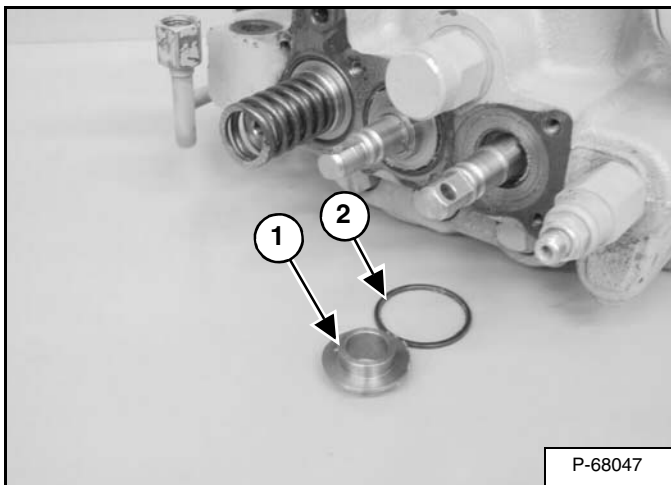

Remove the spacer (Item 1) and O-ring (Item 2) [Figure 20-41-54] from the lift spool.

Figure 20-41-55

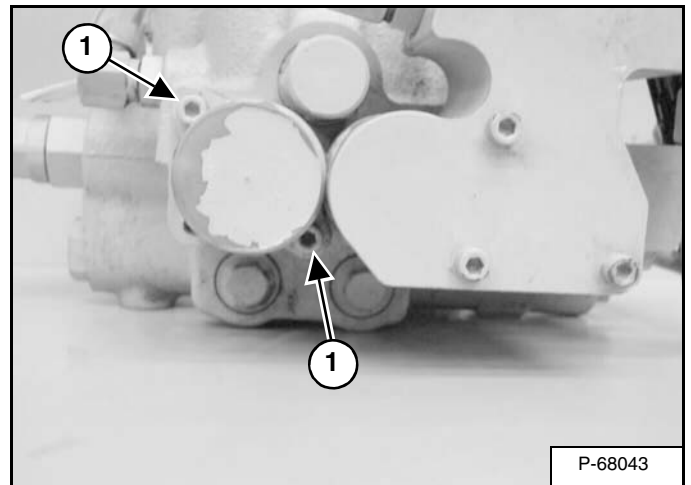

Remove the two screws (Item 1) [Figure 20-41-55] from the lift spool end cap.

Installation: Lubricate the screws and tighten to 90 - 100 in.-lb. (10 - 11,3 N•m) torque.

Figure 20-41-56

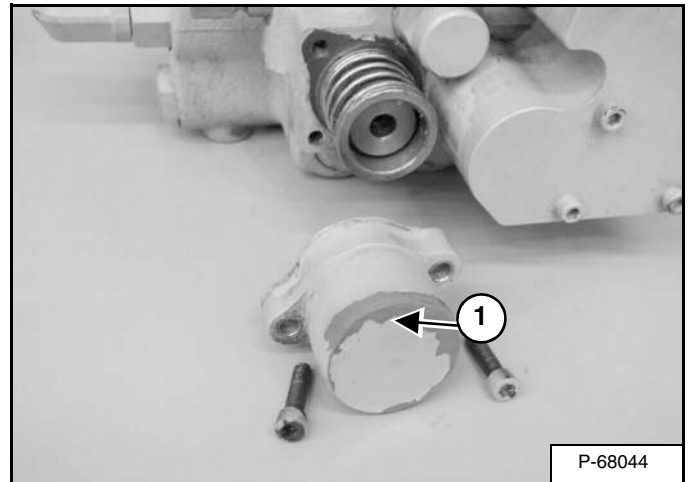

Remove the lift spool end cap (Item 1) [Figure 20-41-56] from the control valve.

HYDRAULIC CONTROL VALVE (ACS) OR (SJC) (CONT'D)

Solenoid Removal And Installation

Figure 20-41-90

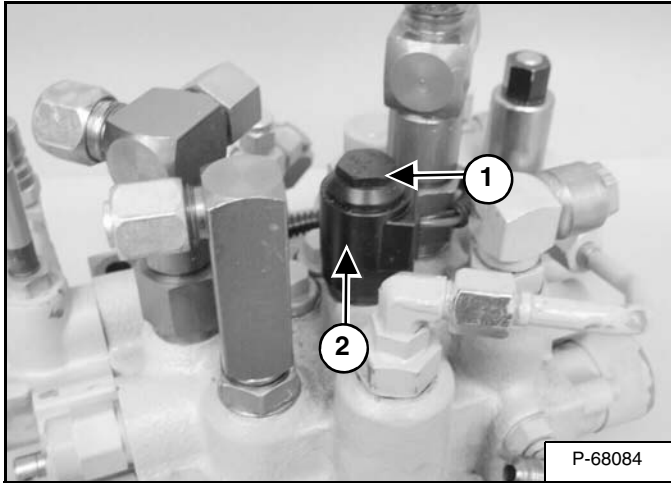

Remove the nut (Item 1) [Figure 20-41-90] from the solenoid stem.

Installation: Tighten the nut to 53 in.-lb. (6 N•m) torque.

Remove the solenoid coil (Item 2) [Figure 20-41-90].

Figure 20-41-91

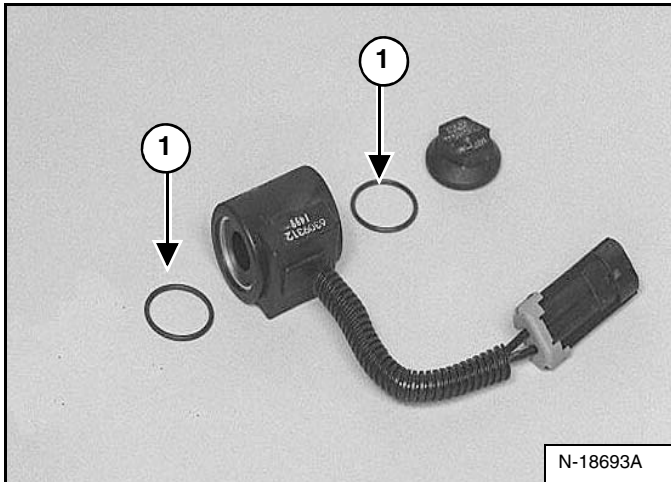

Remove the O-rings (Item 1) [Figure 20-41-91] from both ends of the solenoid coil.

Use an Ohm meter to measure the solenoid coil resistance.

The correct resistance for the coil is 9.79 ± 0.29 Ohms.

Figure 20-41-92

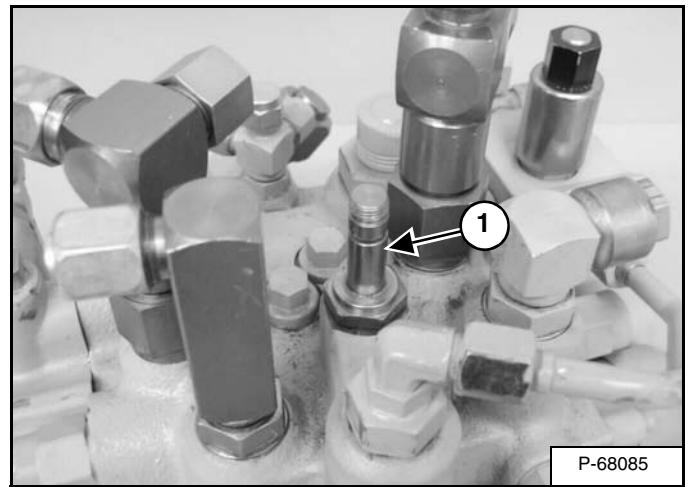

Remove the solenoid stem (Item 1) [Figure 20-41-92].

Installation: Lubricate the O-rings and tighten the stem to 20 - 24 ft.-lb. (27 - 33 N•m) torque.

Figure 20-41-93

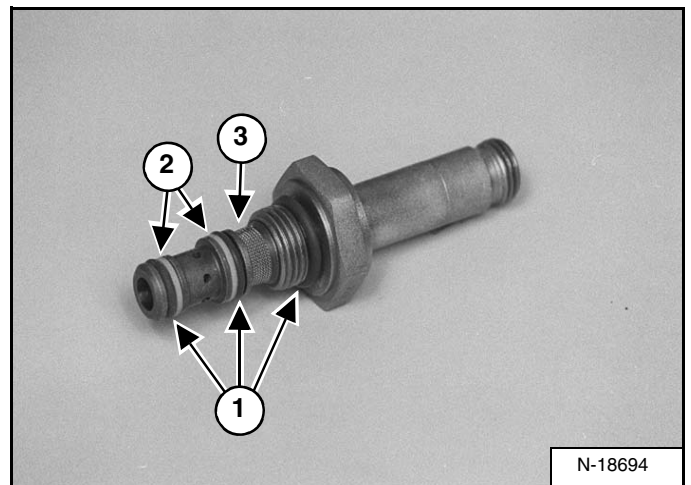

Remove the O-rings (Item 1) and back-up rings (Item 2) [Figure 20-41-93] from the stem.

Clean all parts in solvent and dry with compressed air.

Inspect all parts for wear and replace any showing excessive wear.

NOTE: The screen (Item 3) [Figure 20-41-93] may be cleaned with solvent. If it is torn or worn it needs to be replaced.

Use only new O-rings and apply oil to all O-rings and back-up rings before installation.

Install new O-rings (Item 1) [Figure 20-41-91] & [Figure 20-41-93] and new back-up rings (Item 2) [Figure 20-41-93] on the solenoid stem.

HYDRAULIC PUMP (STANDARD) (CONT'D)

Direct Pump Test (Standard Section) (Cont'd)

Figure 20-60-4

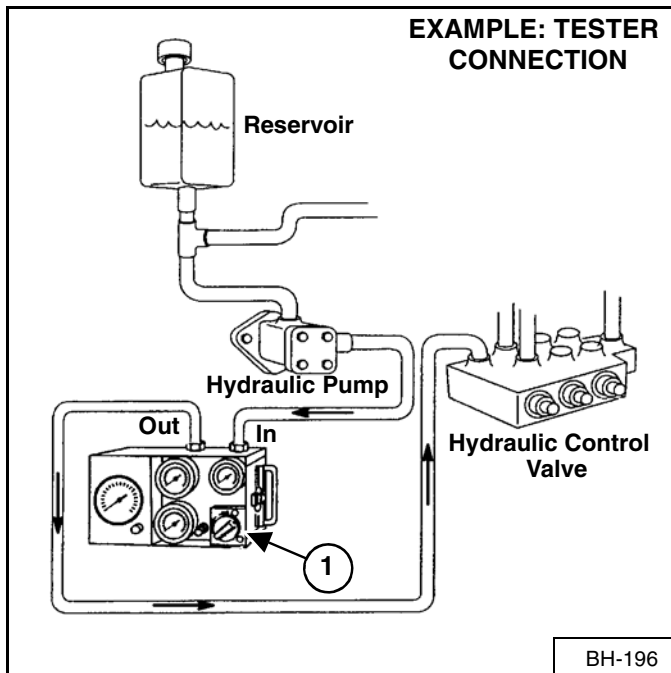

Sample tester connection shown [Figure 20-60-4].

Start the engine and run at low idle RPM. Make sure the tester is connected correctly. If no flow is indicated on the tester, the hoses are connected wrong. With the hoses connected correctly, increase the engine speed to full RPM*.

Warm the fluid to 140° F (60° C) by turning the restrictor control (Item 1) [Figure 20-60-4] on the tester to about 1000 PSI (6895 kPa). DO NOT exceed system relief pressure. Open the restrictor control and record the free flow (GPM) at full RPM*.

Push the maximum/variable flow switch (on the remote start tool) to engage the front auxiliary hydraulics, the light will come ON. Push the button (on the right control lever) for fluid flow to the quick coupler (fluid pressure will go over main relief). Record the highest pressure (PSI) and flow (GPM). The high pressure flow must be at least 80% of free flow.

$$\% = \frac{\text{HIGH PRESSURE FLOW (GPM)}}{\text{FREE FLOW (GPM)}} \times 100$$

A low percentage may indicate a failed pump.

*Refer to (See Hydraulic System on Page SPEC-10-3.) for system relief pressure and full RPM.

HYDRAULIC PUMP (STANDARD) (CONT'D)

Disassembly And Assembly (Cont'd)

Figure 20-60-28

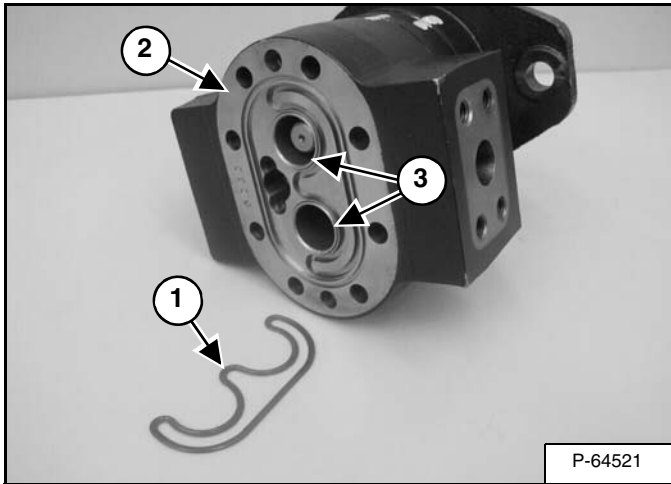

Inspect the pre-load seal (Item 1) [Figure 20-60-28] for damage and replace as needed.

NOTE: Inspect the pump center section (Item 2) and bushings (Item 3) [Figure 20-60-28]. If excessive wear or damage is visible, the pump must be replaced.

Figure 20-60-29

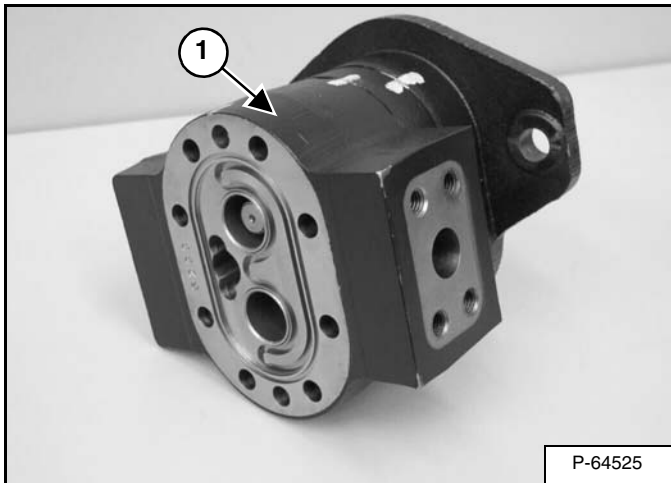

Remove the pump center section (Item 1) [Figure 20-60-29].

Figure 20-60-30

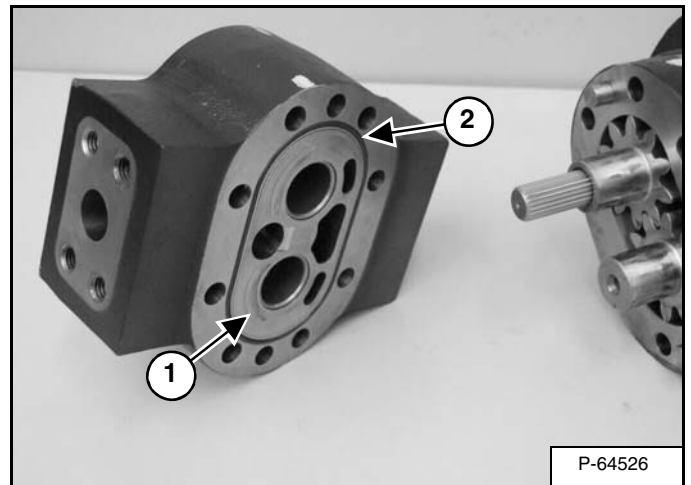
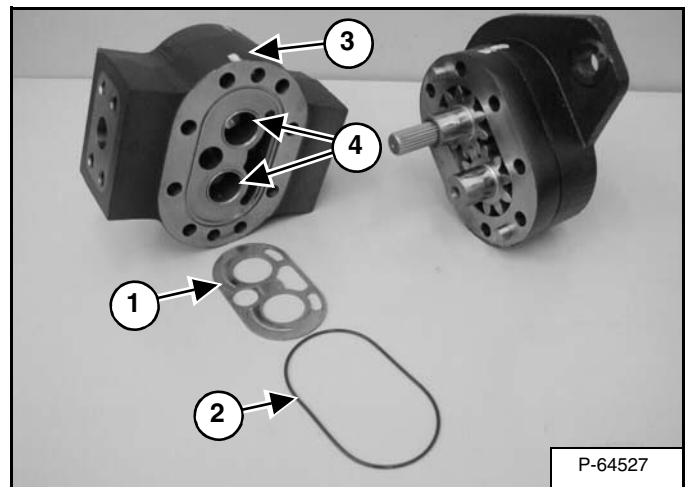

Figure 20-60-31



Remove the wear plate (Item 1) and O-ring (Item 2) [Figure 20-60-30] & [Figure 20-60-31] from the pump center section. Inspect for damage and replace as needed.

NOTE: Position wear plate (Item 1) [Figure 20-60-31] inlets and traps as shown with bronze side toward gears.

NOTE: Inspect the pump center section (Item 3) and bushings (Item 4) [Figure 20-60-31]. If excessive wear or damage is visible, the pump must be replaced.

HYDRAULIC PUMP (STANDARD) (HIGH FLOW) (CONT'D)

Direct Pump Test (Charge Section) (Cont'd)

Figure 20-61-53

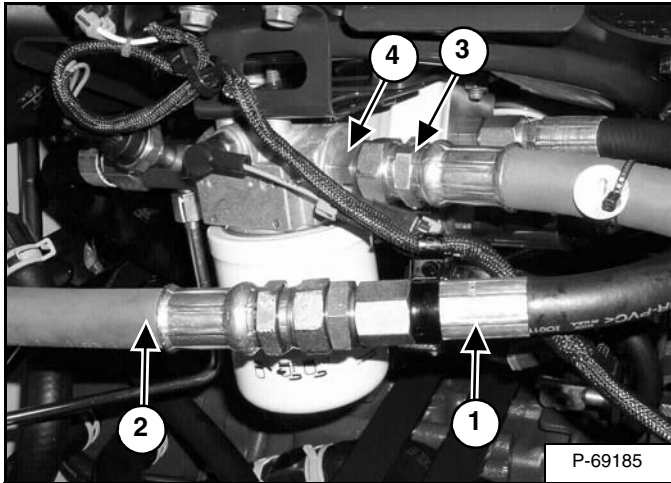

Connect the filter inlet hose (Item 1) to the inlet side of the tester (Item 2) [Figure 20-61-53].

Connect the OUTLET hose (Item 3) from the hydraulic tester to the inlet fitting (Item 4) of the charge filter [Figure 20-61-53].

Figure 20-61-54

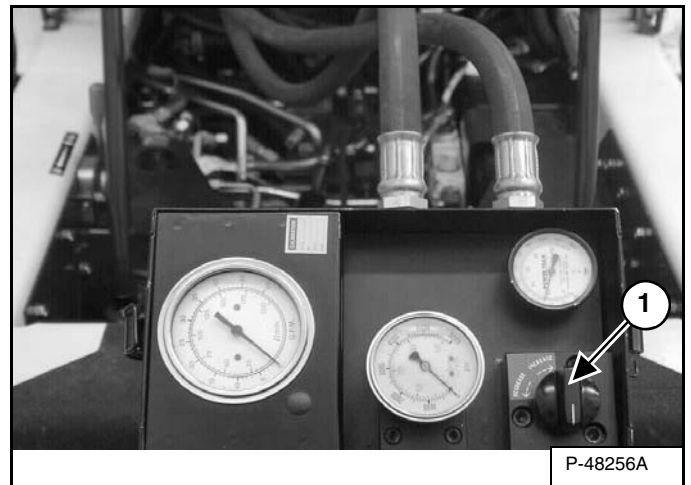

Be sure all connections are tight and that the hoses are not touching any moving parts before starting the loader [Figure 20-61-54].

IMPORTANT

The hydraulic tester must be in the fully open position before you start the engine.

I-2024-0284

Start the engine and run at low idle RPM. Make sure the tester is connected correctly. If no flow is indicated on the tester, the hoses are connected wrong. With the hoses connected correctly, increase the engine speed to full RPM*.

Warm the fluid to 140° F (60° C) by turning the restrictor control (Item 1) [Figure 20-61-54] on the tester to about 600 PSI (41,4 bar). DO NOT exceed 1200 PSI (82,7 bar). Open the restrictor control and record the free flow (GPM) at full RPM*.

Turn the restrictor down to system operating pressure approximately 1000 PSI (69 bar). **DO NOT EXCEED 1200 PSI (82,7 bar)**. Refer to Hydraulic Schematics for flow. The high pressure flow must be at least 80% of free flow.

$$\% = \frac{\text{HIGH PRESSURE FLOW (GPM)}}{\text{FREE FLOW (GPM)}} \times 100$$

A low percentage may indicate a failed pump.

*Refer to the Hydraulic Schematics for pump flow and RPM.

HYDRAULIC PUMP (STANDARD) (HIGH FLOW) (CONT'D)

Disassembly And Assembly (Cont'd)

Figure 20-61-78

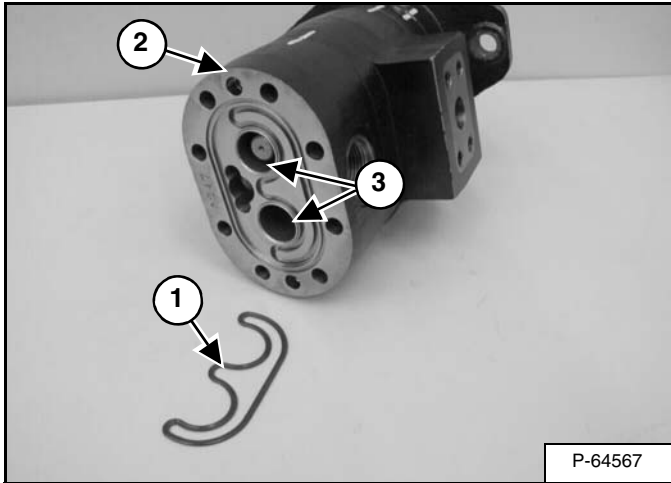

Inspect the pre-load seal (Item 1) [Figure 20-61-78] for damage and replace as needed.

NOTE: Inspect the charge center section (Item 2) and bushings (Item 3) [Figure 20-61-78]. If excessive wear or damage is visible, the pump must be replaced.

Figure 20-61-79

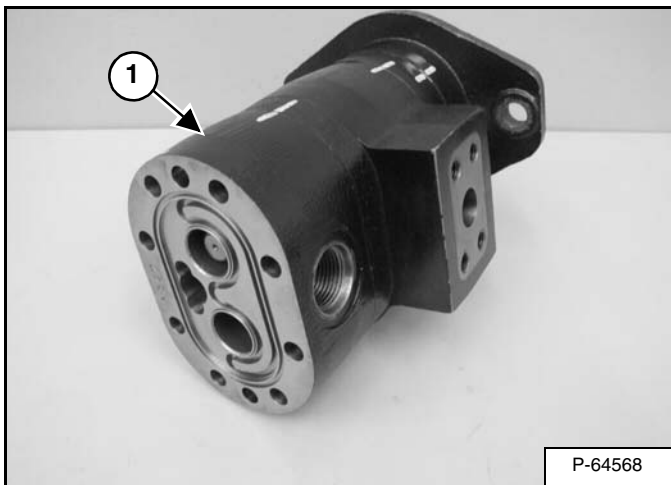

Remove the charge center section (Item 1) [Figure 20-61-79].

Figure 20-61-80

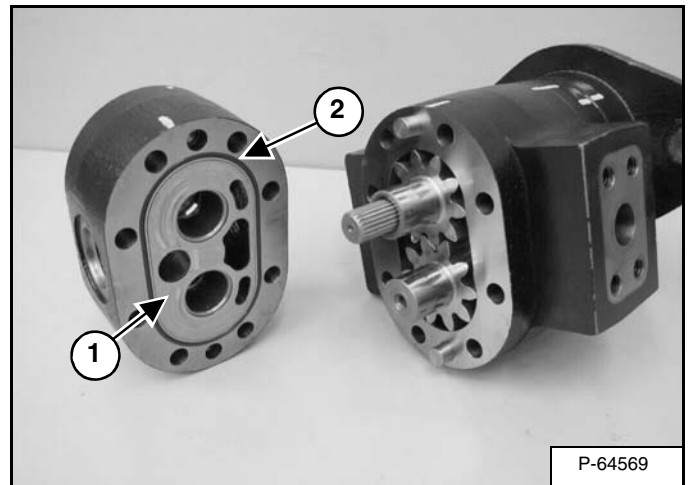
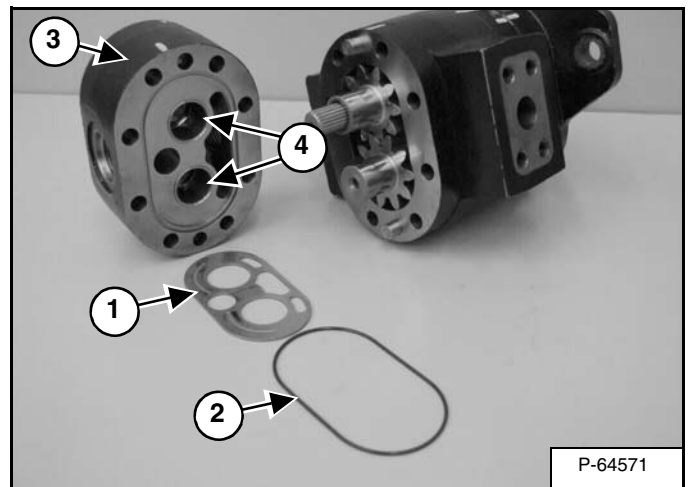

Figure 20-61-81



Remove the wear plate (Item 1) and O-ring (Item 2) [Figure 20-61-80] & [Figure 20-61-81] from the charge center section. Inspect for damage and replace as needed.

NOTE: Position wear plate (Item 1) [Figure 20-61-81] inlets and traps as shown with bronze side toward gears.

NOTE: Inspect the charge center section (Item 3) and bushings (Item 4) [Figure 20-61-81]. If excessive wear or damage is visible, the pump must be replaced.

HYDRAULIC PUMP (SJC)

Description

The hydraulic gear pump is attached to the end of the hydrostatic pumps and is located on the right side of the loader between the hydraulic control valve and the engine.

The hydraulic gear pump is a combination of gear pumps that provide hydraulic flow to several hydraulic systems.

The hydraulic gear pump has a dedicated charge pump. This supplies flow to the hydraulic fan motor and charge pressure to the hydrostatic pump.

A seal kit is available to service the hydraulic pump. If any of the main components of the pump are damaged, the entire pump must be replaced.

Pump Test at Quick Couplers

The tools listed will be needed to do the following procedure:

MEL10003 - In-Line Hydraulic Tester
MEL10006 - Flow Meter Fitting Kit

Figure 20-70-111

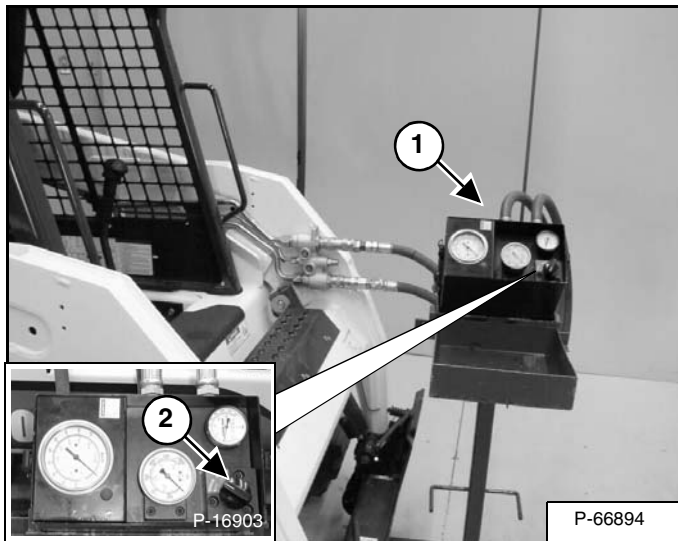

Install a hydraulic tester (Item 1) [Figure 20-70-111] onto the front auxiliary quick couplers.

NOTE: When testing the hydraulic flow of a machine, hoses must be at least 3/4 in. in diameter and connected directly to the hydraulic tester without using any type of “quick coupler” on the connection to the tester. Also make sure your hydraulic tester is capable of at least 50 GPM.

This procedure will require a operator in the cab and one operator running the tester.

Start the engine and run at low idle RPM. Press the Front Auxiliary button. Engage the front auxiliary with the trigger on the right handle. Make sure the tester is connected correctly. If no flow is indicated on the tester, the hoses are connected wrong. With the hoses connected correctly, increase the engine speed to full RPM*.

Warm the fluid to 140° F (60° C) by turning the restrictor control clockwise on the tester so it reads about a 1000 PSI (69 bar).

NOTE: DO NOT EXCEED 3300 PSI.

Turn the restrictor control (Item 2) [Figure 20-70-111] on the tester counterclockwise to obtain free flow, the flow should be approximately 16-17 GPM. Start turning the restrictor clockwise, causing more restriction on the flow. The GPM should drop off slightly until the pressure reaches approximately 2800 PSI. At approximately 2800 PSI the flow should start decreasing rapidly until the pressure reaches 3250 - 3300 PSI. At 3250 - 3300 PSI the flow should be at 0 GPM. Turn the restrictor (Item 2) [Figure 20-70-111] counterclockwise to free flow. Shut the front auxiliary hydraulics off.

If flow and pressure specs are not obtained, go to Direct Pump Testing. (See Direct Pump Test (Standard Section) on Page 20-70-2.)

*Refer to (See Hydraulic System on Page SPEC-10-3.) for system relief pressure and full RPM.

HYDRAULIC PUMP (SJC) (CONT'D)

Disassembly And Assembly (Cont'd)

Figure 20-70-130

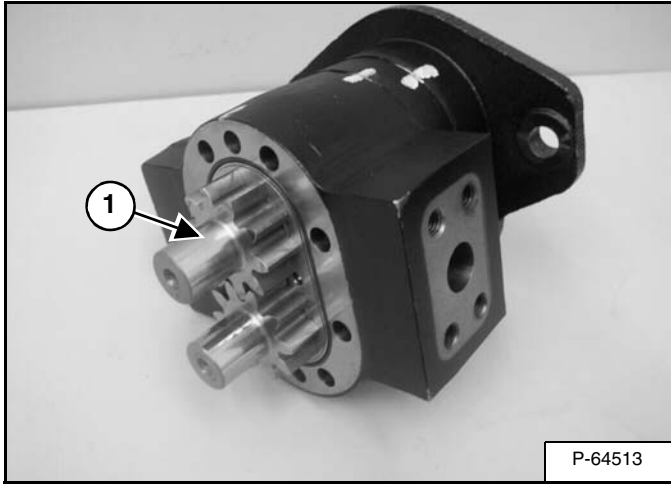
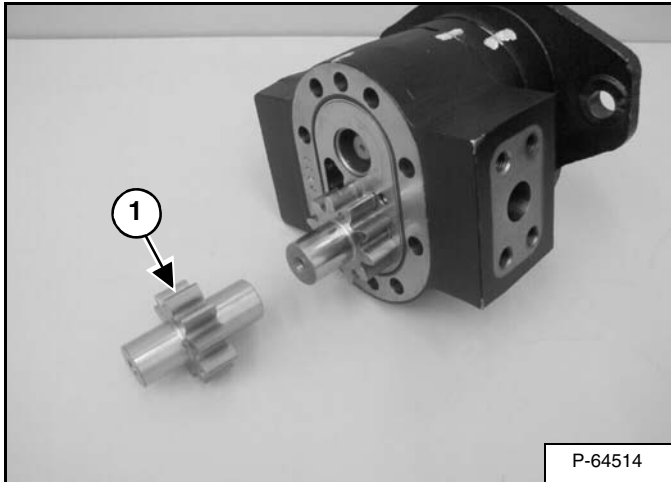

Figure 20-70-131



Remove the drive gear (Item 1) [Figure 20-70-130] & [Figure 20-70-131].

NOTE: Inspect the drive gear (Item 1) [Figure 20-70-131]. If excessive wear or damage is visible, the pump must be replaced.

Figure 20-70-132

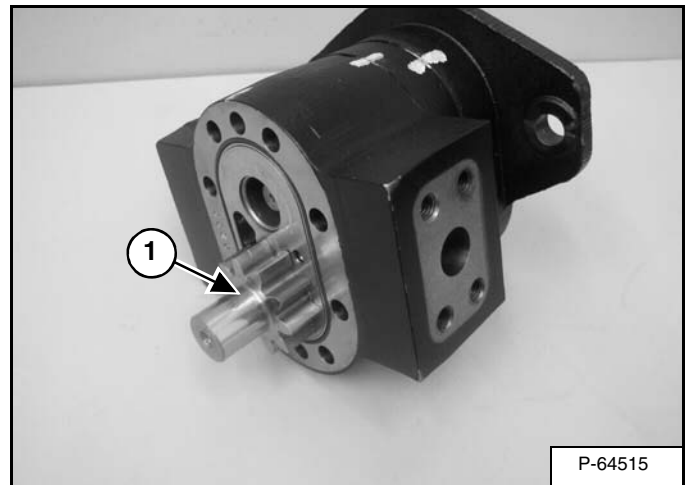
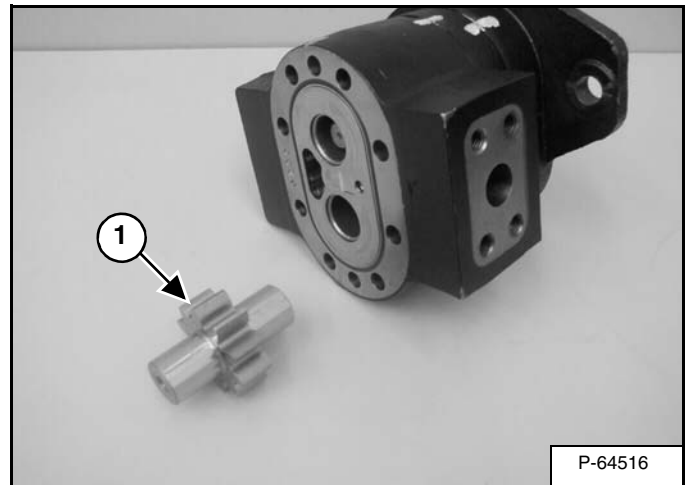

Figure 20-70-133



Remove the idler gear (Item 1) [Figure 20-70-132] & [Figure 20-70-133] from the pump center section.

NOTE: Inspect the idler gear (Item 1) [Figure 20-70-133]. If excessive wear or damage is visible, the pump must be replaced.

HYDRAULIC PUMP (SJC) (HIGH FLOW) (CONT'D)

Direct Pump Test (Standard Section) (Cont'd)

Figure 20-71-160

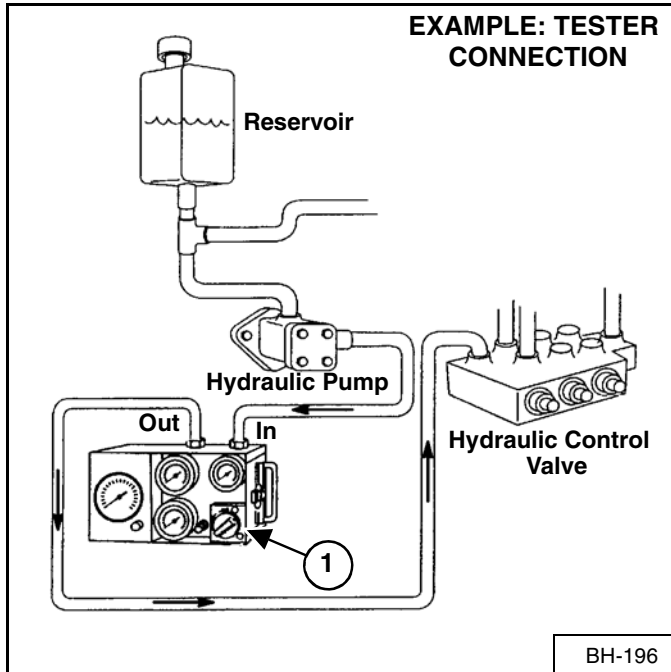

Sample tester connection shown [Figure 20-71-160].

Start the engine and run at low idle RPM. Make sure the tester is connected correctly. If no flow is indicated on the tester, the hoses are connected wrong. With the hoses connected correctly, increase the engine speed to full RPM*.

Warm the fluid to 140° F (60° C) by turning the restrictor control (Item 1) [Figure 20-71-160] on the tester to about 1000 PSI (6895 kPa). DO NOT exceed system relief pressure. Open the restrictor control and record the free flow (GPM) at full RPM*.

Push the maximum/variable flow switch (on the remote start tool) to engage the front auxiliary hydraulics, the light will come ON. Push the button (on the right control lever) for fluid flow to the quick coupler (fluid pressure will go over main relief). Record the highest pressure (PSI) and flow (GPM). The high pressure flow must be at least 80% of free flow.

$$\% = \frac{\text{HIGH PRESSURE FLOW (GPM)}}{\text{FREE FLOW (GPM)}} \times 100$$

A low percentage may indicate a failed pump.

*Refer to (See Hydraulic System on Page SPEC-10-3.) for system relief pressure and full RPM.

HYDRAULIC PUMP (SJC) (HIGH FLOW) (CONT'D)

Disassembly And Assembly (Cont'd)

Figure 20-71-181

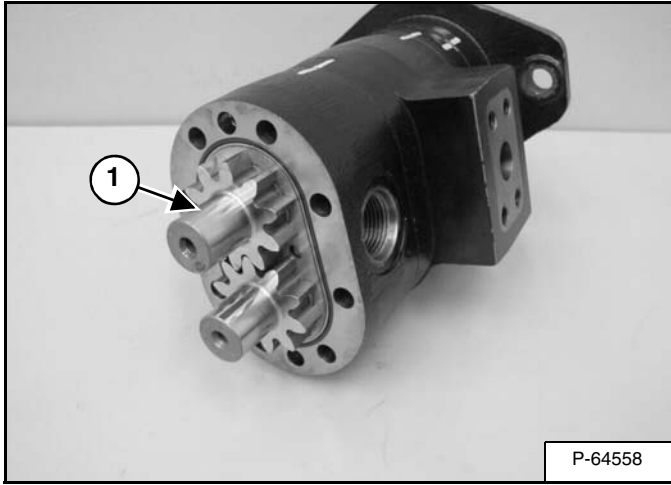
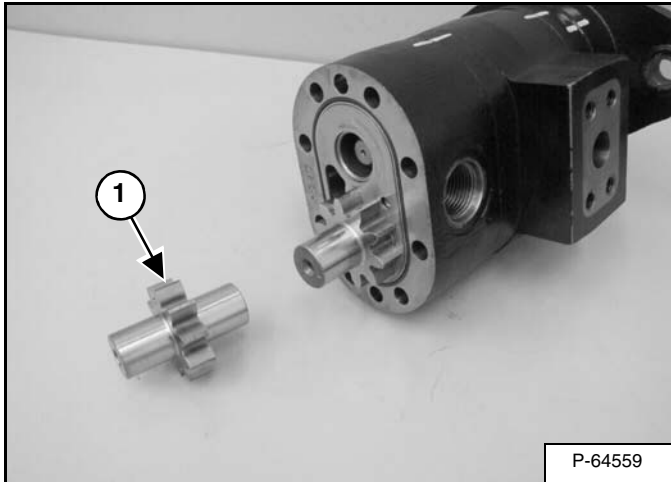

Figure 20-71-182



Remove the drive gear (Item 1) [Figure 20-71-181] & [Figure 20-71-182].

NOTE: Inspect the drive gear (Item 1) [Figure 20-71-182]. If excessive wear or damage is visible, the pump must be replaced.

Figure 20-71-183

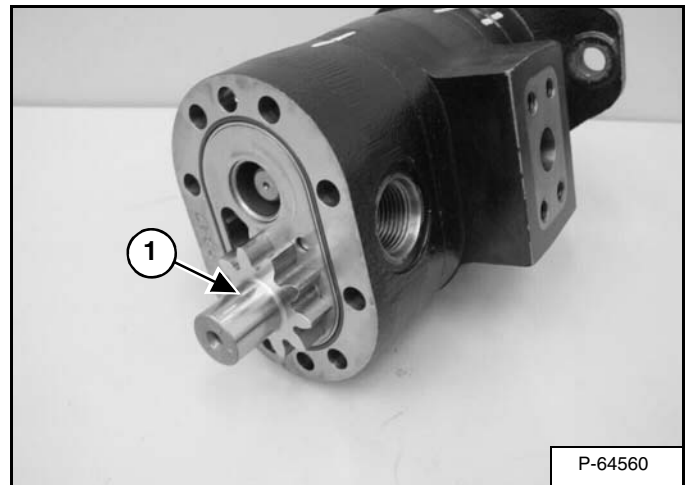
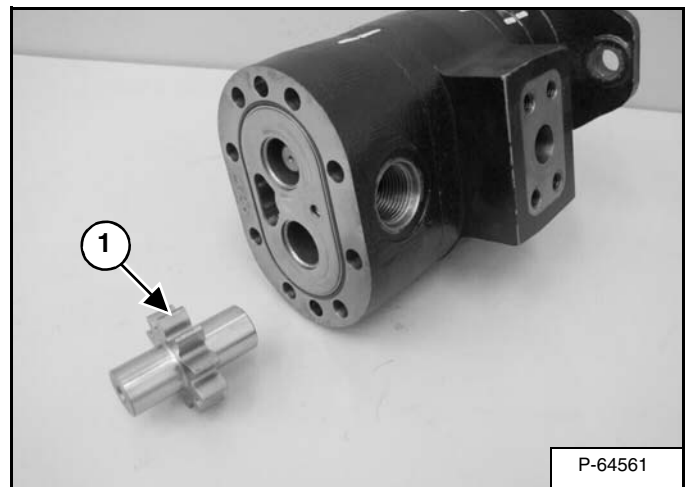

Figure 20-71-184



Remove the idler gear (Item 1) [Figure 20-71-183] & [Figure 20-71-184] from the charge center section.

NOTE: Inspect the idler gear (Item 1) [Figure 20-71-184]. If excessive wear or damage is visible, the pump must be replaced.

HYDRAULIC PUMP (SJC) (HIGH FLOW) (CONT'D)

Hydraulic Pump Start Up

NOTE: This procedure to prevent a dry start up of the hydraulic pump.

Figure 20-71-219

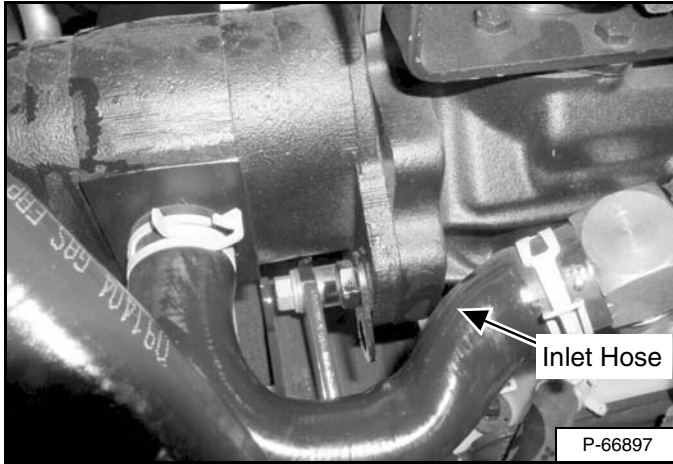

Disconnect the pump inlet hose connection at the front of the hydrostatic pump. Fill the pump inlet and hose completely with hydraulic fluid. Reconnect the hose [Figure 20-71-219].

Figure 20-71-220

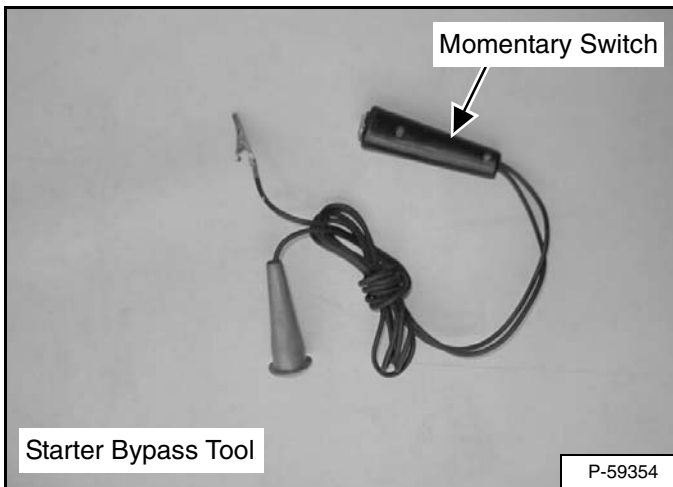

[Figure 20-71-220] To crank the engine without starting, the machine key switch can be bypassed. Obtain a starter bypass tool from a local source which can be used as a universal connection to remotely crank the engine without starting.

The starter bypass tool consists of two wires, each with a clamp. The momentary switch, when depressed, will allow current to pass through the circuit.

Figure 20-71-221

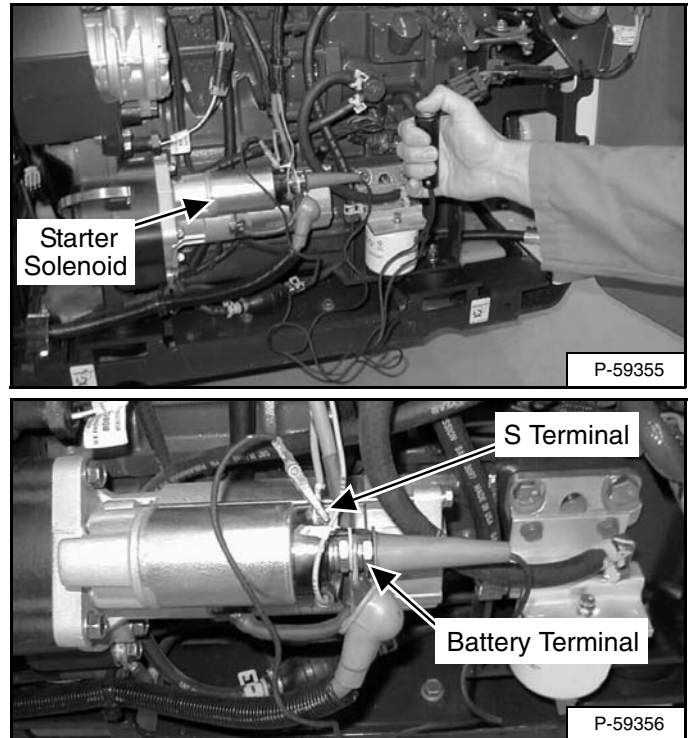

Connect the starter bypass tool to the starter solenoid battery terminal and S terminal. Crank the engine for 15 seconds, then stop for at least 30 seconds. Again, crank the engine for 15 seconds. Remove the starter bypass tool [Figure 20-71-221].

Start the loader from the operators cab and run the engine at low idle for 1 - 2 minutes without operating the hydraulics.

After operating the engine at low idle, Remove the lift arm support device and fully raise and lower the loader lift arms several times or until air is purged from the system. **Avoid running over the relief valve setting at the end of cylinder stroke.**

With the loader parked on a level surface and lift arms down, check and fill the hydraulic reservoir as required. Check for hydraulic leaks.

OIL COOLER

Description

The oil cooler is used to cool the loaders hydraulic and hydrostatic oil. Oil passages are coiled into a heat exchanger. Air is forced, with the cooling fan, around the passages cooling the oil.

The oil cooler is located underneath the rear grill between the A/C condenser (if so equipped) and the radiator.

Removal and Installation

IMPORTANT

When repairing hydrostatic and hydraulic systems, clean the work area before disassembly and keep all parts clean. Always use caps and plugs on hoses, tubelines and ports to keep dirt out. Dirt can quickly damage the system.

I-2003-0888

Remove the rear grill from the loader. (See Removal And Installation on Page 50-60-1.)

Figure 20-100-1

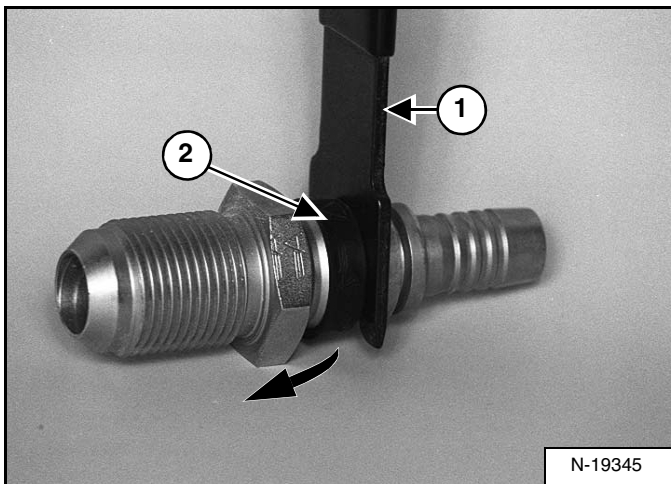

Install tool MEL 1558 (Item 1) to outside of rubber sleeve (Item 2) [Figure 20-100-1].

Figure 20-100-2

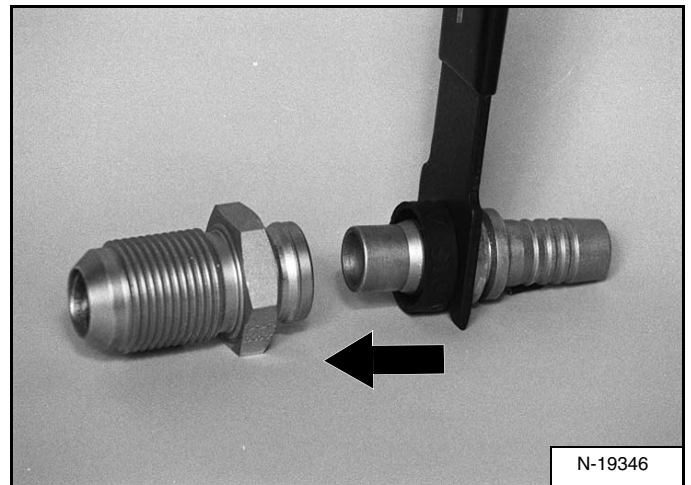
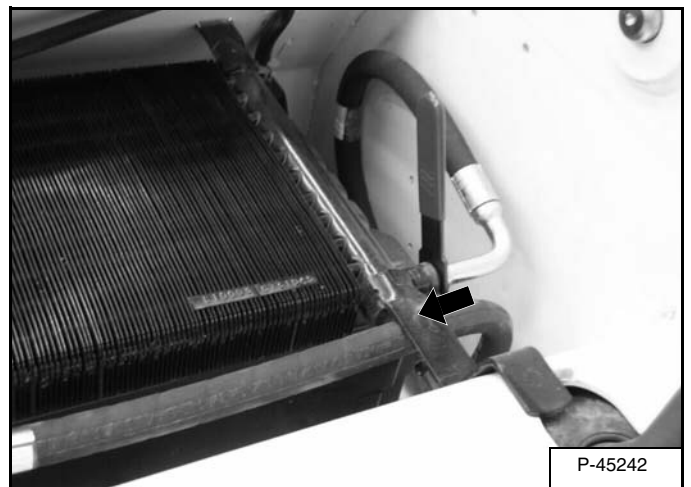

Figure 20-100-3



Slide the rubber sleeve in toward the radiator. The connector will release [Figure 20-100-2] & [Figure 20-100-3].

REAR AUXILIARY DIVERTER VALVE (CONT'D)

Removal And Installation (Cont'd)

Figure 20-120-6

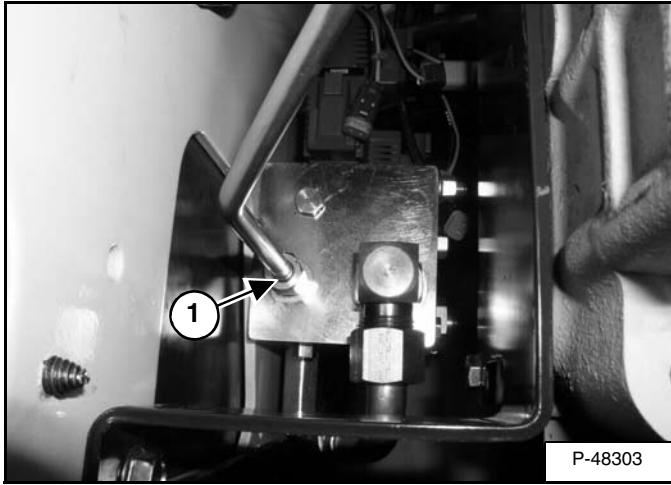

Disconnect and remove the drain tubeline (Item 1) [Figure 20-120-6] from the rear auxiliary valve.

Figure 20-120-7

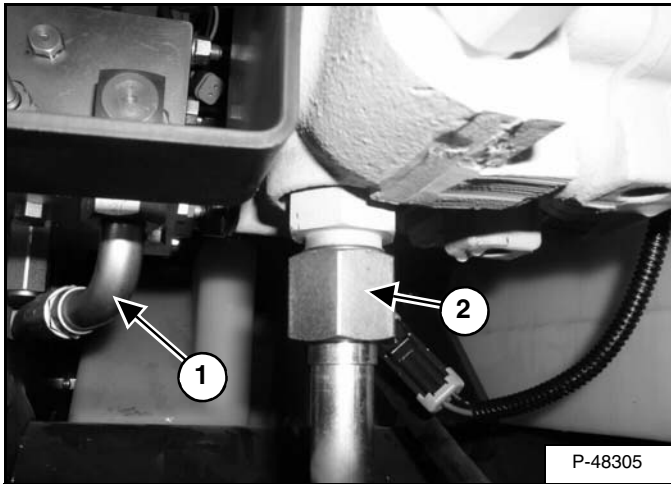

Disconnect the pump outlet hose (Item 1) [Figure 20-120-7] from the rear auxiliary valve.

Disconnect the tubeline (Item 2) [Figure 20-120-7] from the bottom of the control valve and the rear auxiliary valve.

Figure 20-120-8

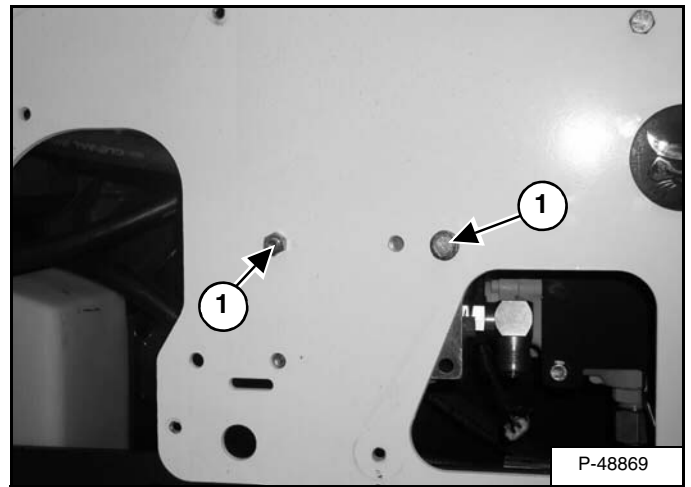

Loosen and remove the two bolts and nuts (Item 1) [Figure 20-120-8] that hold the rear auxiliary valve.

Figure 20-120-9

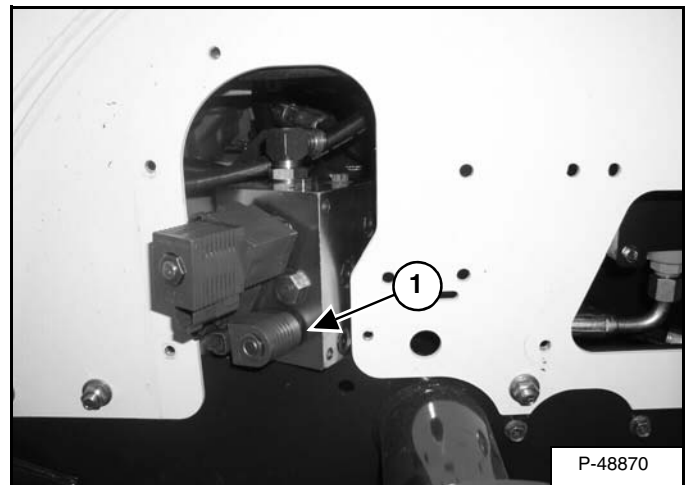

Remove the rear auxiliary valve (Item 1) [Figure 20-120-9] by moving the valve to the rear access hole which allows enough room for the valve to be removed from the loader.

The valve needs to be tilted as shown in [Figure 20-120-9] for it to be removed through the hole.

POWER BOB-TACH BLOCK (CONT'D)

Disassembly And Assembly

Figure 20-130-5

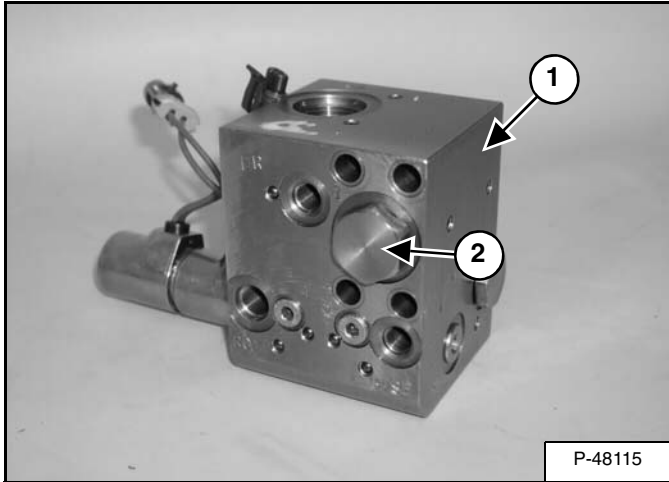

Clean the block (Item 1) [Figure 20-130-5] to remove dirt before disassembly. Block ports are labeled for correct assembly.

Remove the plug (Item 2) [Figure 20-130-5].

Assembly: Tighten the plug to 25 - 30 ft.-lb. (34 - 40,6 N•m) torque.

IMPORTANT

When repairing hydrostatic and hydraulic systems, clean the work area before disassembly and keep all parts clean. Always use caps and plugs on hoses, tubelines and ports to keep dirt out. Dirt can quickly damage the system.

I-2003-0888

Figure 20-130-6

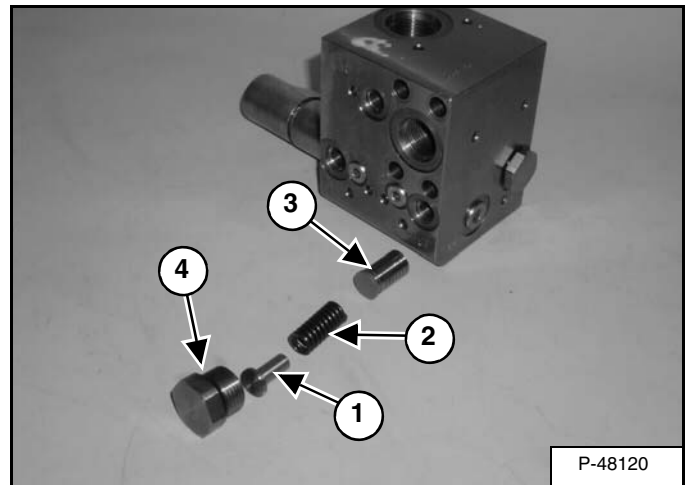

Remove the spring guide (Item 1), spring (Item 2) and the spool (Item 3) [Figure 20-130-6].

Check the O-ring (Item 4) [Figure 20-130-6] on the plug and replace as needed.

Figure 20-130-7

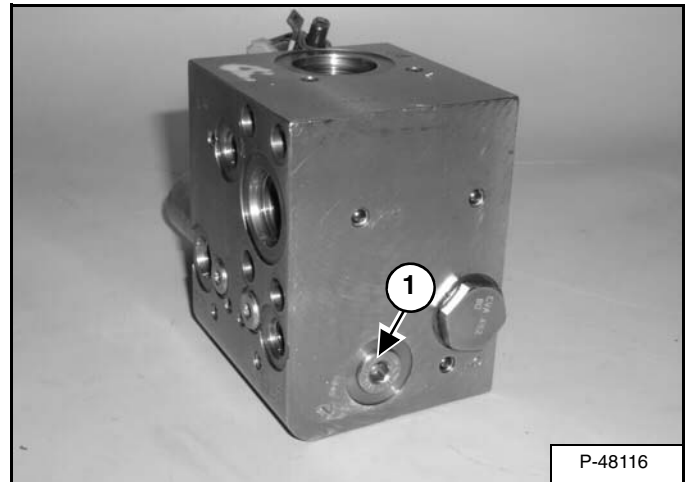

NOTE: This plug is a zero leak plug and should not be removed. If removed damage may occur and the plug and O-ring must be replaced.

Do not remove the plug (Item 1) [Figure 20-130-7].

Assembly: Tighten the plug to 12 - 14 ft.-lb. (16,3 - 19 N•m) torque.

HIGH FLOW VALVE (CONT'D)

Removal And Installation (Cont'd)

Figure 20-150-10

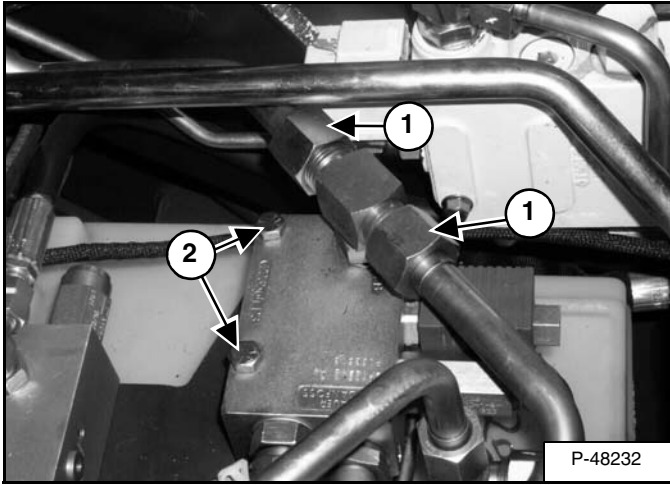

Disconnect and cap the tubelines (Item 1) [Figure 20-150-10] to the tilt cylinders.

Remove the two mounting bolts (Item 2) [Figure 20-150-10].

Installation: Tighten the mounting bolts to 25 - 28 ft.-lb. (34 - 38 N•m) torque.

Disassembly And Assembly

Figure 20-150-11

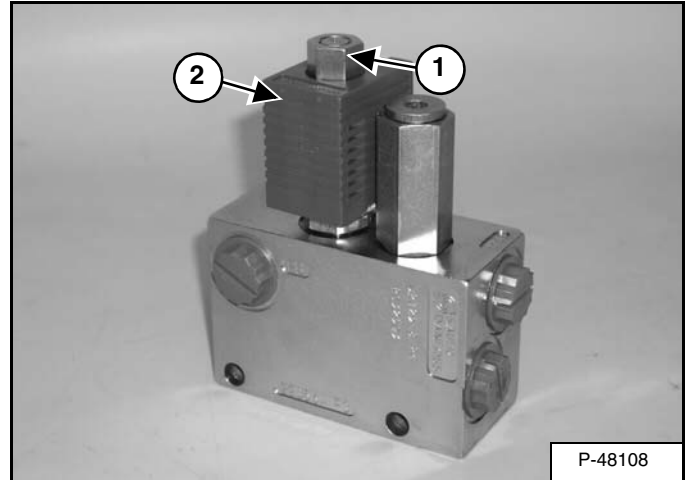

Remove the solenoid nut (Item 1) and solenoid (Item 2) [Figure 20-150-11] from the solenoid valve.

Assembly: Tighten to 4 - 6 ft.-lb. (5 - 8 N•m) torque.

Figure 20-150-12

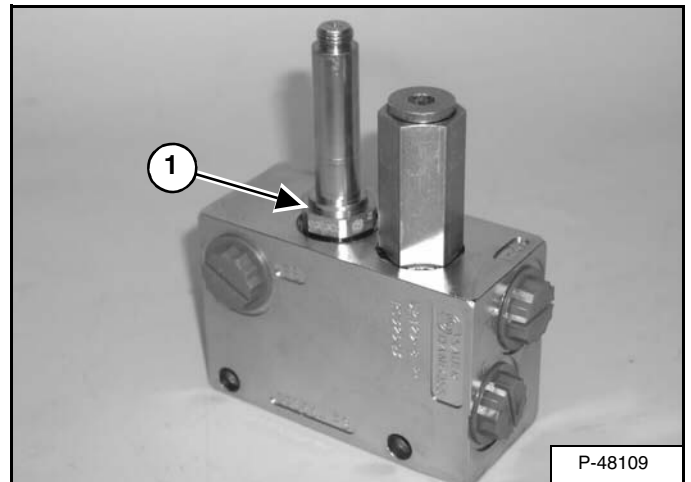

Remove the solenoid valve (Item 1) [Figure 20-150-12] from the valve.

Assembly: Tighten to 30 - 35 ft.-lb. (41 - 47 N•m) torque.

HYDROSTATIC MOTOR (CONT'D)

Removal And Installation (Cont'd)

Figure 30-20-5

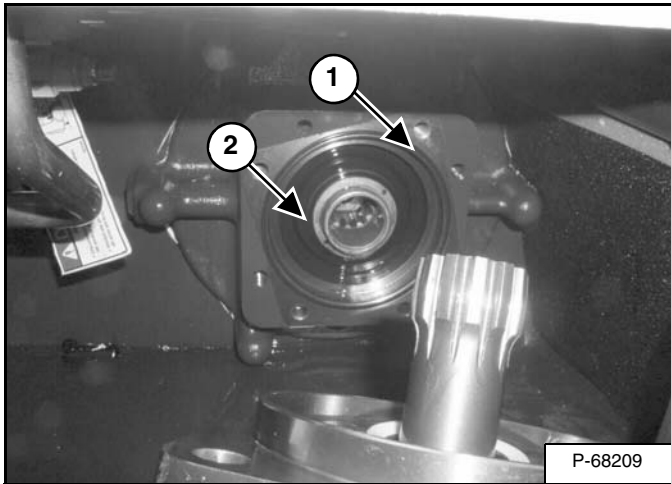

Remove the hydrostatic motor from the access hole in the loader frame [Figure 30-20-5].

Inspect hydrostatic motor O-ring (Item 1) and carrier shaft seal (Item 2) [Figure 30-20-5].

Reverse the removal procedure to install the hydrostatic motor.

HYDROSTATIC MOTOR (TWO-SPEED) (CONT'D)

Removal And Installation (Left Side) (Cont'd)

Figure 30-21-3

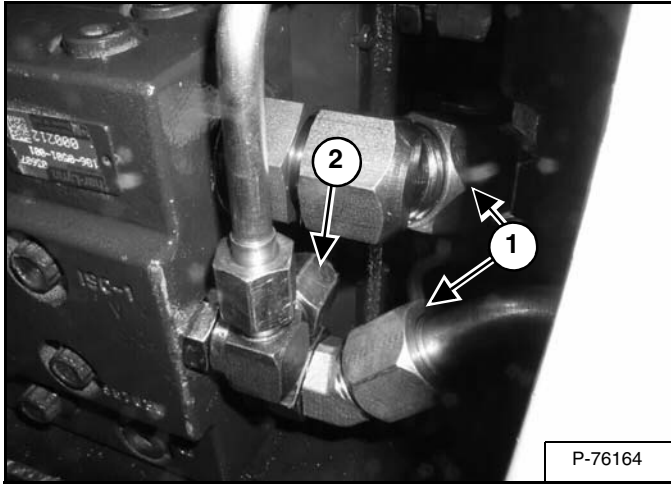

Mark the hoses and tubeline for correct installation.

Disconnect both high pressure hydraulic tubelines (Item 1) [Figure 30-21-3] from the motor.

Disconnect the pre-warming tubeline (Item 2) [Figure 30-21-3] from the motor.

Figure 30-21-4

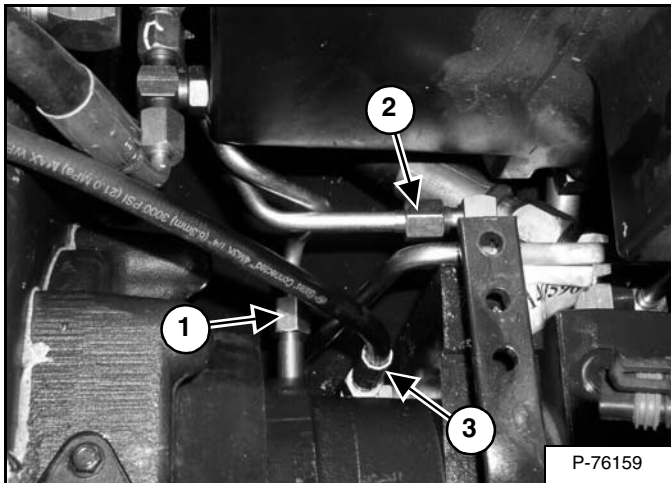

Mark the hose and tubelines for correct installation.

Disconnect the case drain tubeline (Item 1) [Figure 30-21-4] from the motor.

Disconnect the shift pressure tubeline (Item 2) [Figure 30-21-4] from the motor.

Disconnect the hose (Item 3) [Figure 30-21-4] from the motor.

Figure 30-21-5

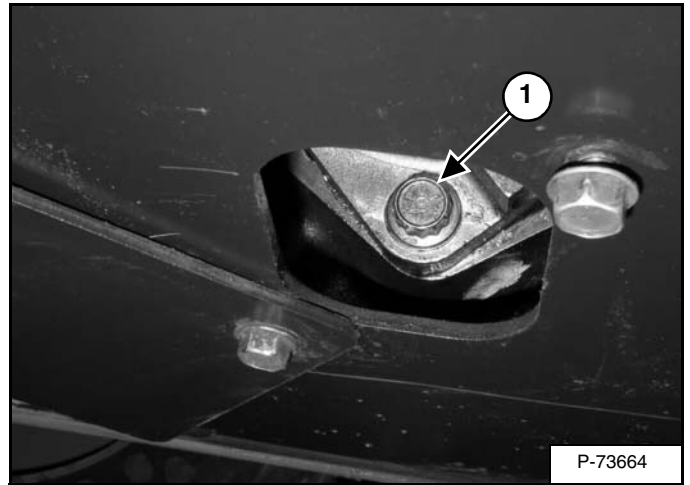

Remove the lower mounting bolt (Item 1) [Figure 30-21-5] from the motor.

Installation: Tighten the mounting bolt to 210 ft.-lb. (285 N•m) torque.

Figure 30-21-6

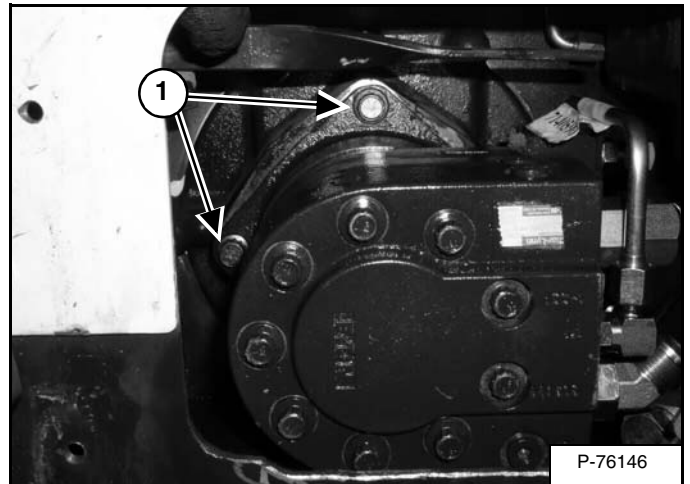

Remove two mounting bolts (Item 1) [Figure 30-21-6] from the motor.

Installation: Tighten the mounting bolts to 210 ft.-lb. (285 N•m) torque.

Remove the motor from the access hole in the loader frame.

HYDROSTATIC MOTOR (TWO-SPEED) (CONT'D)

Disassembly (Cont'd)

Figure 30-21-34

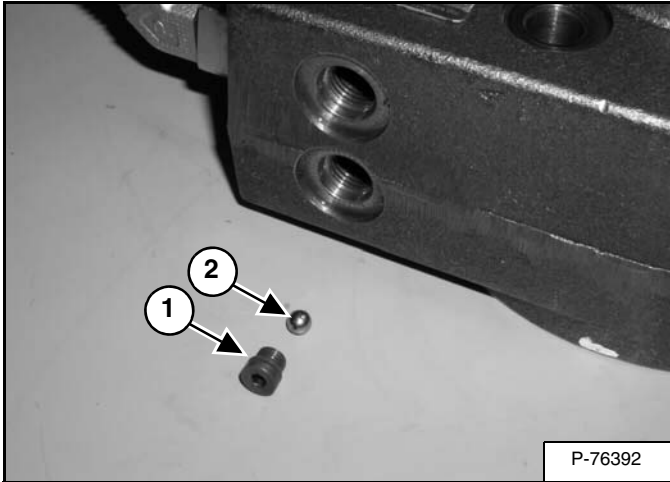

Remove the ball seat (Item 1) and ball (Item 2) [Figure 30-21-34] from the valve housing.

NOTE: To remove the ball seat, use a long allen wrench to reach down into the valve housing.

Figure 30-21-35

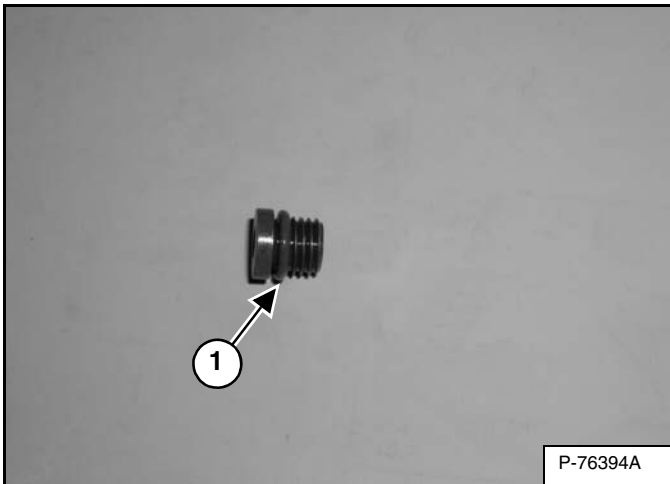

Remove O-ring (Item 1) [Figure 30-21-35] on plug.

Figure 30-21-36

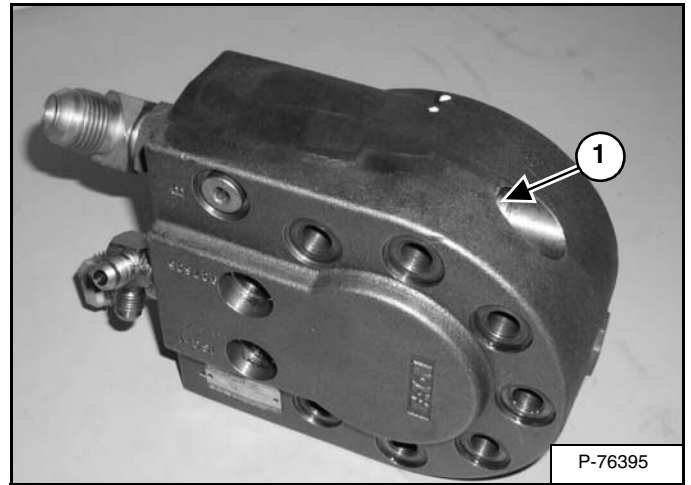

Remove the plug (Item 1) [Figure 30-21-36] from the valve housing.

Figure 30-21-37

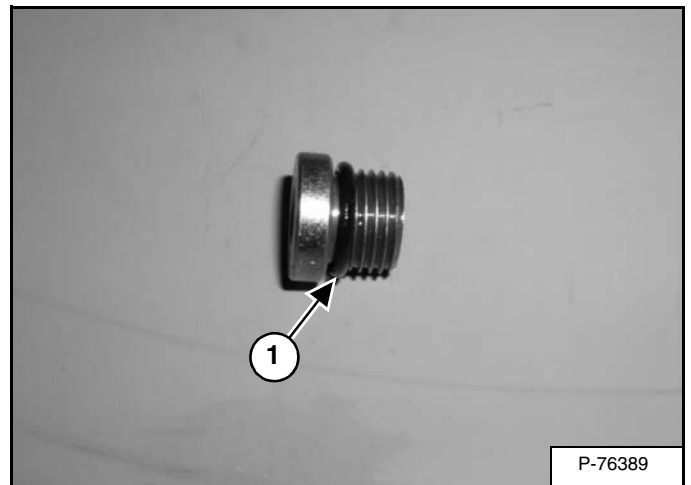

Remove O-ring (Item 1) [Figure 30-21-37] on plug.

HYDROSTATIC MOTOR (TWO-SPEED) (CONT'D)

Assembly (Cont'd)

Motor Timing (Cont'd)

Figure 30-21-71

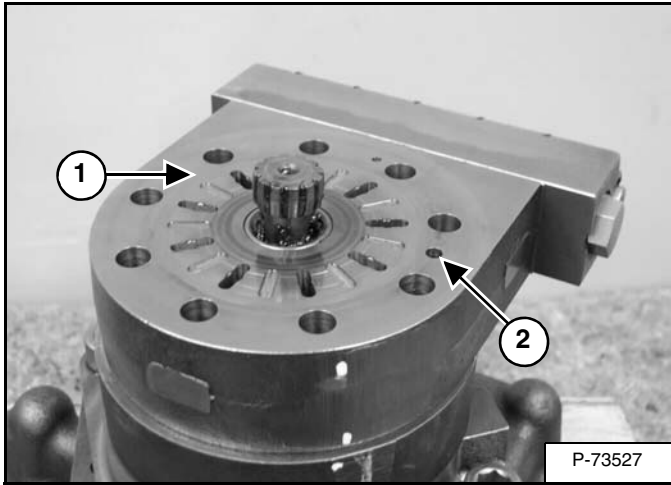

Install the selector plate (Item 1) with the slotted holes facing up. Be sure to line up the shuttle flow hole (Item 2) [Figure 30-21-71].

Figure 30-21-72

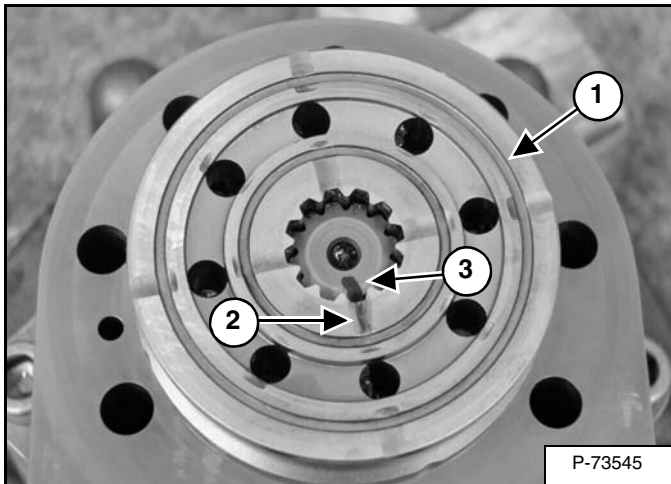

Install the valve (Item 1) [Figure 30-21-72] on the valve drive. The round holes and four grooves must be facing up.

Align any one of the four grooves (Item 2) in the valve with the marked tooth on the valve drive (Item 3) [Figure 30-21-72].

Figure 30-21-73

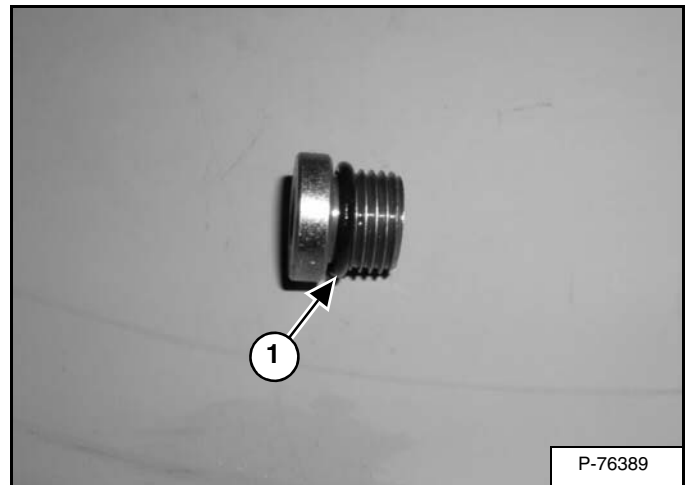

Install new O-rings (Item 1) [Figure 30-21-73] on both plugs.

Figure 30-21-74

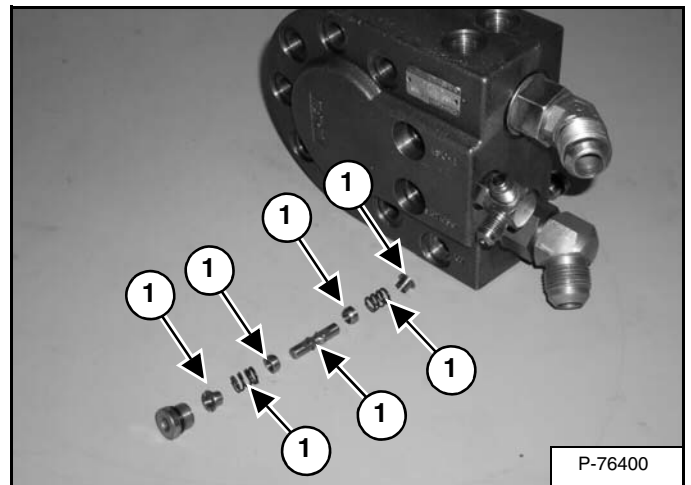

Assemble the shuttle valve assembly (Item 1) [Figure 30-21-74] and insert into the valve housing.

HYDROSTATIC MOTOR CARRIER (SINGLE AND TWO-SPEED WITH MANUAL CONTROLS) (CONT'D)

Shaft Seal Removal And Installation (Cont'd)

Figure 30-30-6

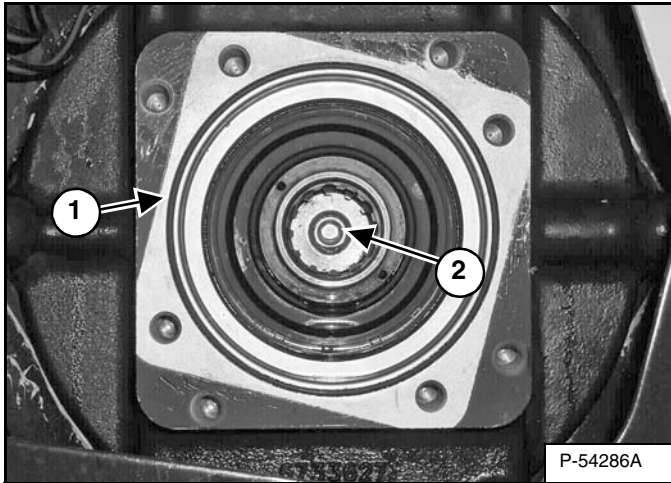

Photo [Figure 30-30-6] shows the motor carrier seal correctly installed.

Inspect the O-ring (Item 1) [Figure 30-30-6] and replace if needed.

NOTE: Before reinstalling the hydrostatic motor, check the plug (Item 2) [Figure 30-30-6] located in the center of the carrier shaft for tightness. If the plug becomes loosened, case drain lubrication oil from the hydrostatic motor can leak into the chaincase.

Removal And Installation

WARNING

Never work on a machine with the lift arms up unless the lift arms are secured by an approved lift arm support device. Failure to use an approved lift arm support device can allow the lift arms or attachment to fall and cause injury or death.

W-2059-0598

Raise the loader lift arms and install an approved lift arm support device. (See Installing on Page 10-20-1.)

Lift and block the loader. (See Procedure on Page 10-10-1.)

Raise the loader operator cab. (See Raising on Page 10-30-2.)

Drain the fluid from the chaincase. (See CHAINCASE on Page 40-30-1.)

Remove the engine speed control. (See Removal And Installation on Page 70-20-1.)

Remove the control panel. (See Removal and Installation on Page 50-100-2.)

Remove the lift arm bypass control valve. (See Removal and Installation on Page 20-50-1.)

Remove the traction lock assembly. (See Removal And Installation on Page 60-120-2.)

Remove the center chaincase cover. (See Center Cover Removal And Installation on Page 40-30-2.)

Remove the front chaincase cover. (See Front Cover Removal And Installation on Page 40-30-1.)

Remove the front axle and sprocket. (See Axle Sprocket And Bearings Removal And Installation on Page 40-20-4.)

Remove the hydrostatic motor. (Refer to HYDROSTATIC MOTOR on Page 30-20-1.) or (See HYDROSTATIC MOTOR (TWO-SPEED) on Page 30-21-1.)

HYDROSTATIC MOTOR CARRIER (SINGLE AND TWO-SPEED WITH SJC CONTROLS) (CONT'D)

Shaft Seal Removal And Installation (Cont'd)

Figure 30-31-6

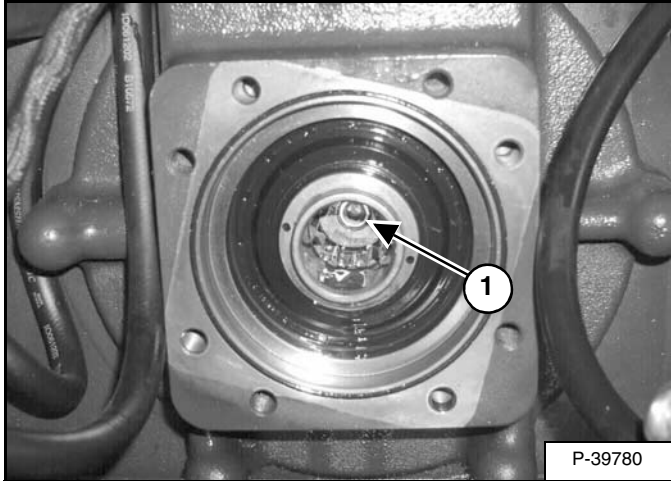

Photo [Figure 30-31-6] shows the motor carrier seal correctly installed.

NOTE: Before reinstalling the hydrostatic motor, check the plug (Item 1) [Figure 30-31-6] located in the center of the carrier shaft for tightness. If the plug becomes loosened, case drain lubrication oil from the hydrostatic motor can leak into the chaincase.

Removal And Installation

WARNING

Never work on a machine with the lift arms up unless the lift arms are secured by an approved lift arm support device. Failure to use an approved lift arm support device can allow the lift arms or attachment to fall and cause injury or death.

W-2059-0598

Raise the loader lift arms and install an approved lift arm support device. (See Installing on Page 10-20-1.)

Lift and block the loader. (See Procedure on Page 10-10-1.)

Raise the loader operator cab. (See Raising on Page 10-30-2.)

Drain the fluid from the chaincase. (See Removing And Replacing Oil on Page 40-30-1.)

Remove the engine speed control. (See Removal And Installation on Page 70-20-1.)

Remove the control panel. (See Removal and Installation on Page 50-100-2.)

Remove the lift arm bypass control valve. (See Removal and Installation on Page 20-50-1.)

Remove the traction lock assembly. (See Removal And Installation on Page 60-120-2.)

Remove the center chaincase cover. (See Center Cover Removal And Installation on Page 40-30-2.)

Remove the front chaincase cover. (See Front Cover Removal And Installation on Page 40-30-1.)

Remove the front axle and sprocket. (See Axle Sprocket And Bearings Removal And Installation on Page 40-20-4.)

Remove the hydrostatic motor. (See HYDROSTATIC MOTOR on Page 30-20-1.) or (See HYDROSTATIC MOTOR (TWO-SPEED) on Page 30-21-1.)

CHARGE PRESSURE (CONT'D)

Sender Removal And Installation

Figure 30-40-5

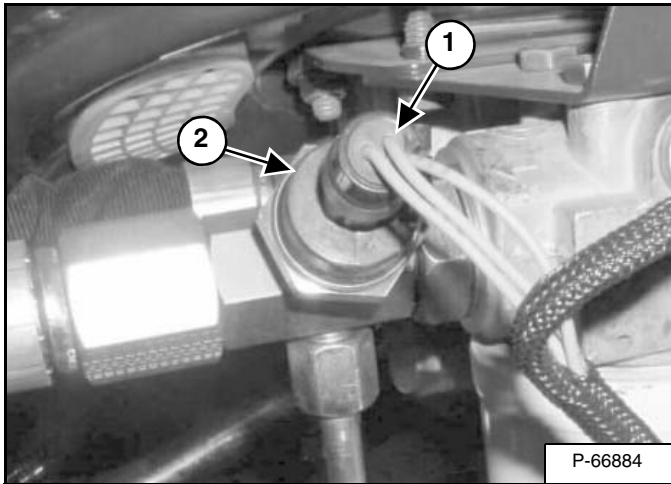

Disconnect the charge pressure sender connector (Item 1) [Figure 30-40-5] from the sender.

Remove the sender (Item 2) [Figure 30-40-5] from the adapter fitting.

Installation: Tighten the charge pressure sender to 7.4 - 8.1 ft.-lb. (10 - 11 N•m) torque.

HYDROSTATIC PUMP (CONT'D)

Disassembly (Cont'd)

Figure 30-50-11

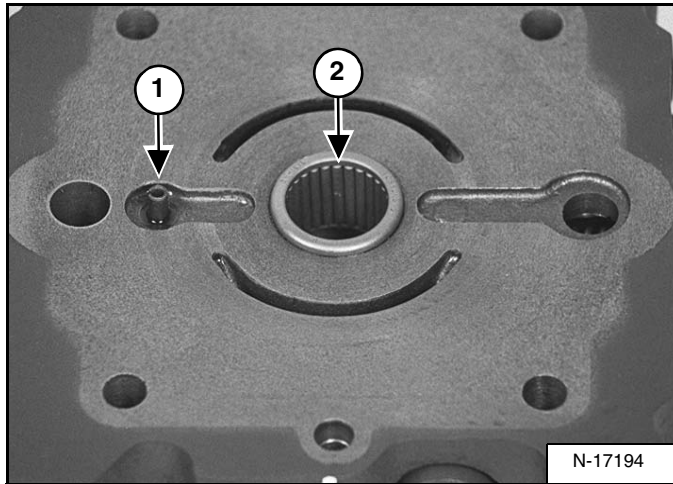

Check the valve plate locating pin (Item 1) [Figure 30-50-11] for wear and replace if needed.

Check the needle bearing (Item 2) [Figure 30-50-11] for wear and replace if needed.

Figure 30-50-12

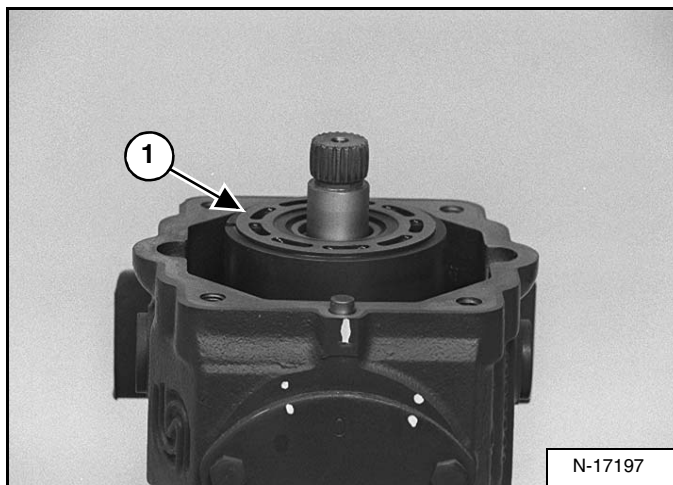

Remove the rotating group (Item 1) [Figure 30-50-12] from the pump.

Figure 30-50-13

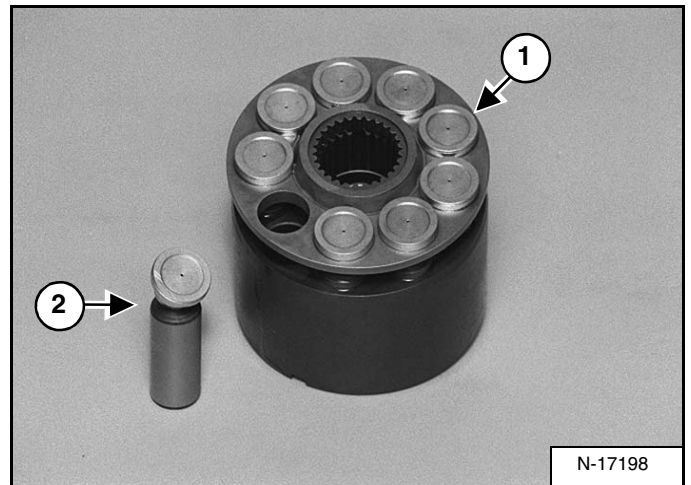

Remove the slipper guide and pistons (Item 1) [Figure 30-50-13] from the cylinder block.

Check all the pistons (Item 2) [Figure 30-50-13] for wear and replace the rotating group as needed.

Figure 30-50-14

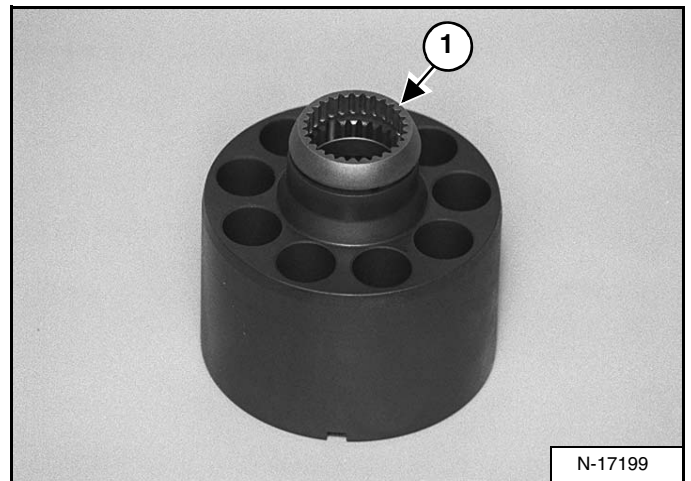

Remove the ball guide retainer (Item 1) [Figure 30-50-14] from the cylinder block.

HYDROSTATIC PUMP (CONT'D)

Assembly (Cont'd)

Figure 30-50-50

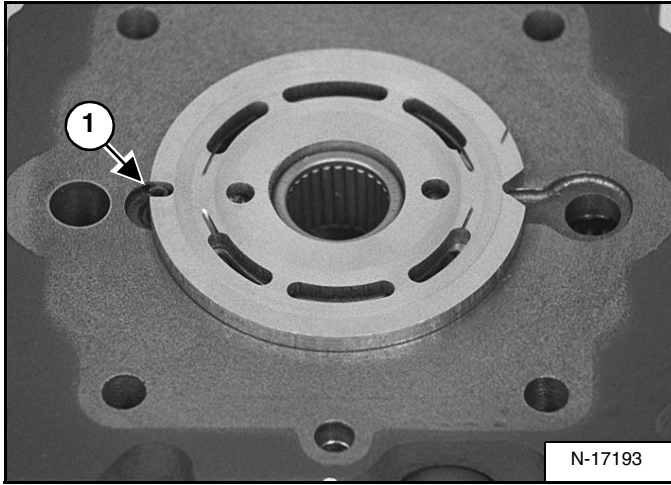

Coat the backside of the valve plate with petroleum jelly to hold it in position and install the valve plate onto the charge pump, bronze face up [Figure 30-50-50].

The notch (Item 1) [Figure 30-50-50] on the valve plate must engage the locating pin.

Figure 30-50-51

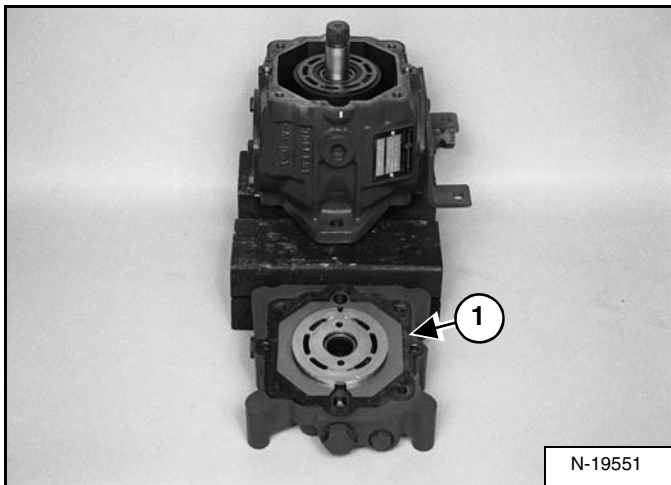

Coat a new end cap gasket (Item 1) [Figure 30-50-51] with petroleum jelly and install onto the end cap.

Figure 30-50-52

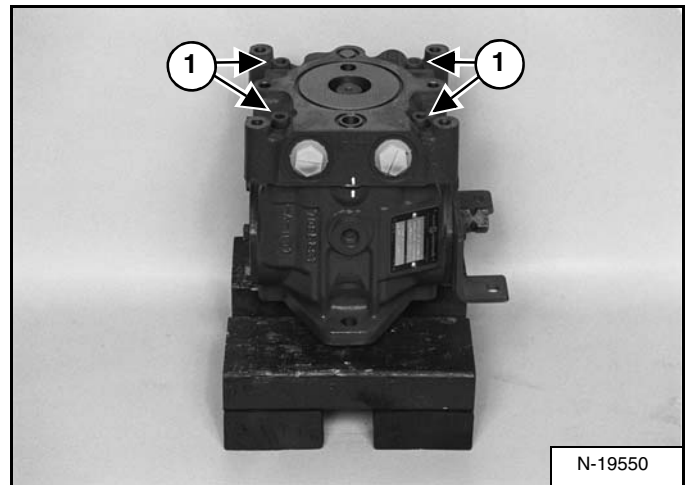

Install the valve plate and end cap on the pump housing. Tighten the bolts (Item 1) [Figure 30-50-52] to 35 - 45 ft.-lb. (47 - 61 N•m) torque.

Figure 30-50-53

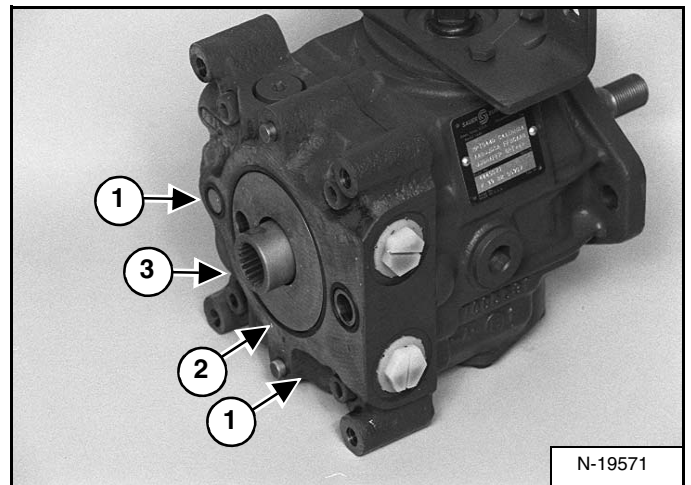

Install the two small O-rings (Item 1) [Figure 30-50-53].

Install the large new O-ring (Item 2) [Figure 30-50-53].

Install the pump coupler (Item 3) [Figure 30-50-53].

HYDROSTATIC PUMP (SJC) (CONT'D)

Charge Relief Valve

Figure 30-51-19

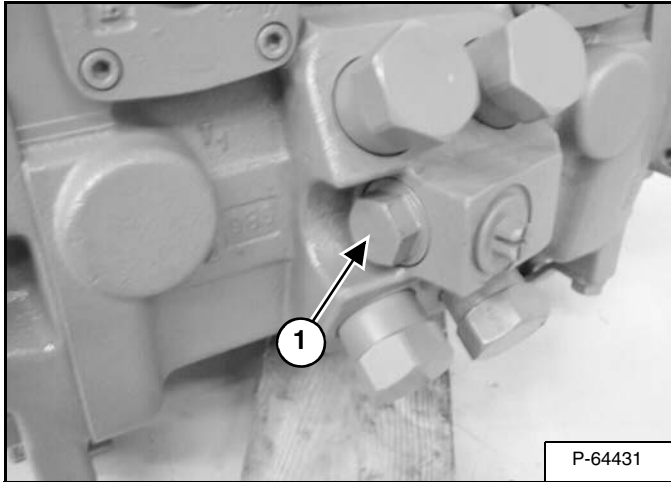

The charge relief valve (Item 1) [Figure 30-51-19] is located on the back of the hydrostatic pump.

Remove the charge relief valve.

Assembly: Tighten charge relief valve to 52 ft.-lb. (70 N•m) torque.

Figure 30-51-20

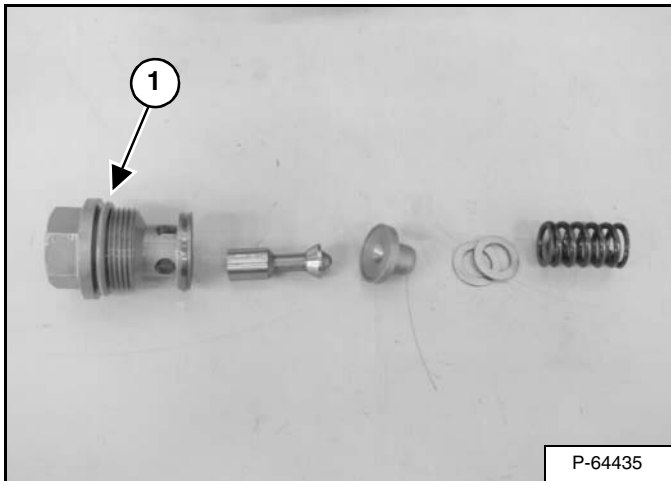

Check and replace the O-ring (Item 1) [Figure 30-51-20].

Figure 30-51-21

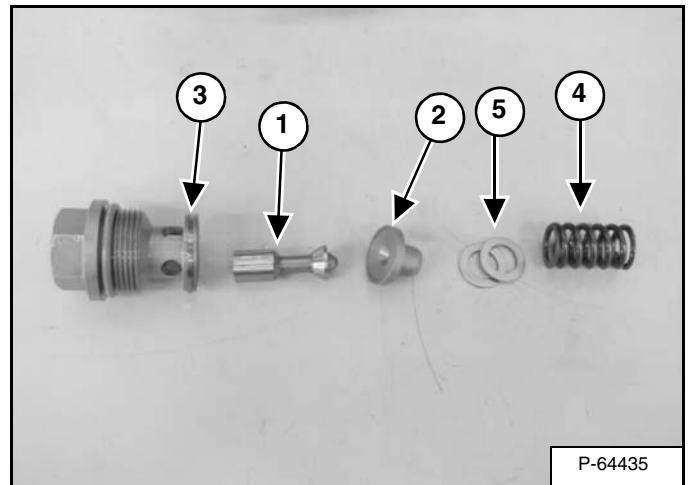

Inspect the poppet (Item 1) and the mating seat (Item 2) [Figure 30-51-21] for damage or foreign material. Ensure the poppet moves freely in its bore.

Inspect the sealing ring (Item 3) [Figure 30-51-21] and the mating seat in the pump housing for damage or foreign material.

Inspect the spring (Item 4) and the charge relief valve shims (Item 5) [Figure 30-51-21].

NOTE: 1.0 mm shim (Item 5) [Figure 30-51-21] = 43.5 PSI (3 bar) in pressure change. Adding shims increases charge pressure. Removing shims decreases charge pressure.

HYDROSTATIC PUMP (SJC) (CONT'D)

Disassembly and Assembly (Cont'd)

Figure 30-51-53

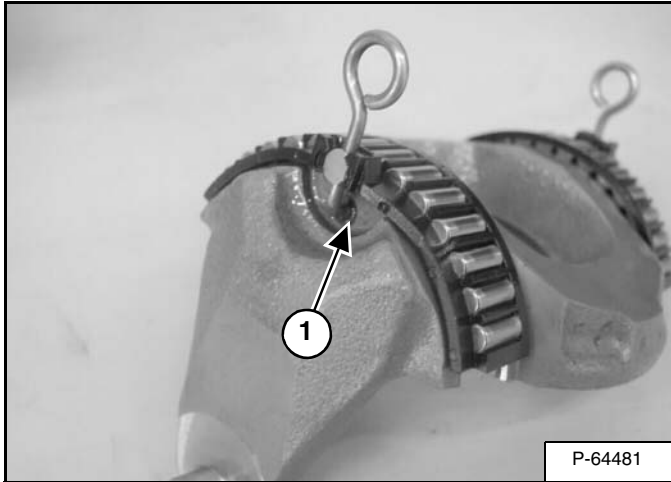

Assembly: Ensure bearing pins are in the holes of the swash plate (Item 1) [Figure 30-51-53].

Figure 30-51-54

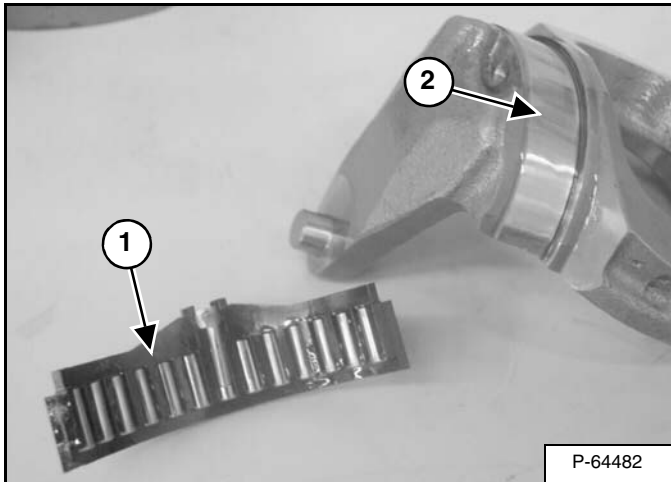

Remove the shell bearing (Item 1) [Figure 30-51-54].

Inspect individual roller bearings and machined surfaces (Item 2) [Figure 30-51-54] on swash plate.

Figure 30-51-55

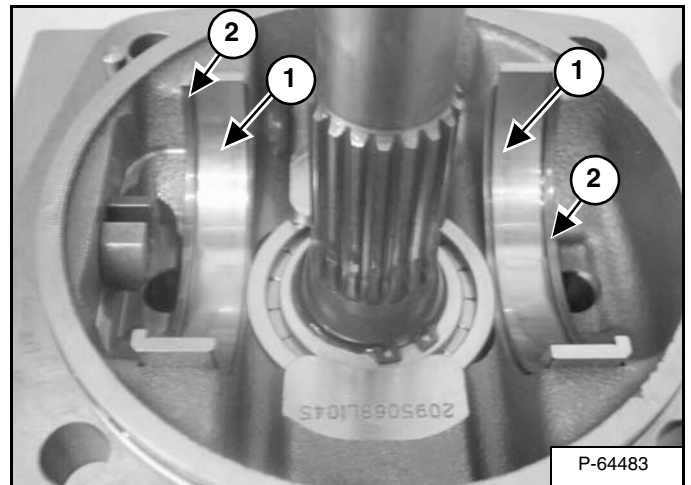

Remove the shell bearing races (Item 1) [Figure 30-51-55].

Assembly: Note shell bearing races have an edge (Item 2) [Figure 30-51-55] on them. The edges face towards the outside of the endcap housing

Inspect bearing surfaces for scratches or scoring.

HYDROSTATIC PUMP (SJC) (CONT'D)

Mechanical Neutral Adjustment (Cont'd)

Figure 30-51-88

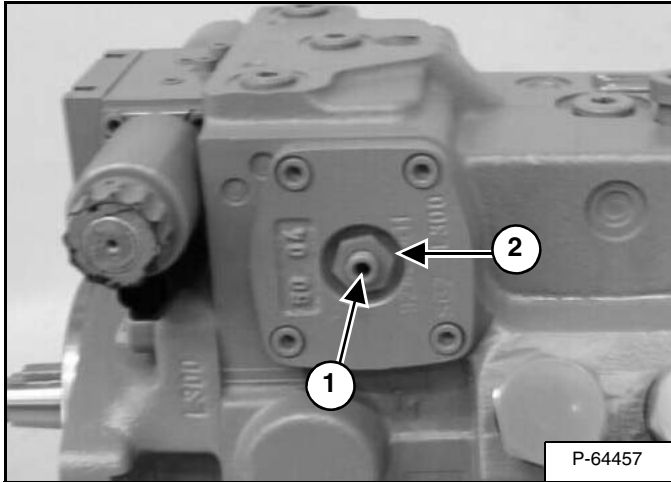

While holding the adjustment screw (Item 1) in position, tighten the lock nut (Item 2) [Figure 30-51-88] to 22 ft.-lb. (30 N•m) torque.

Shut loader OFF.

Remove the hydraulic hose from the X1 and X2 ports on the pump. Install the plugs and tighten to 18 ft.-lb. (25 N•m) torque.

Remove the pressure gauges from the MA and MB ports on the pump. Install the plugs and tighten to 18 ft.-lb. (25 N•m) torque.

NOTE: The Hydraulic Controller Neutral Adjustment must be performed whenever the Mechanical Neutral Adjustment is done. (See Hydraulic Controller Neutral Adjustment on Page 30-41-29.)

Hydraulic Controller Neutral Adjustment

The hydraulic controller neutral adjustment, aligns the pump swash plate and the control spool so that a zero angle control setting provides a zero degree swash plate setting. This adjustment should be performed whenever any part of the control or swash plate mechanisms are adjusted or removed or after the pump mechanical neutral setting is adjusted. Ensure the pump mechanical neutral setting is correct before performing hydraulic controller neutral adjustments.

NOTE: Procedure is shown for the left side hydraulic controller. Procedure is the same for the right side hydraulic controller, except you disconnect the electrical connectors for the right side hydraulic controller and connect pressure gauges in the X1 and X2 ports on the right side of the pump.

Place the loader on jack stands. (See Procedure on Page 10-10-1.)

WARNING

Put jackstands under the front axles and rear corners of the frame before running the engine for service. Failure to use jackstands can allow the machine to fall or move and cause injury or death.

W-2017-0286

Raise the lift arms, and install an approved lift arm support device. (See Installing on Page 10-20-1.)

Raise the operator cab. (See Raising on Page 10-30-2.)

Connect the remote start tool. (See REMOTE START TOOL KIT-MEL1563 on Page 10-60-1.)

WARNING

Hydraulic fluid escaping under pressure can have sufficient force to enter a person's body by penetrating the skin. This can cause serious injury and possible death if proper medical treatment by a physician familiar with this injury is not received immediately.

W-2145-0290

DRIVE BELT (CONT'D)

Belt Tensioner Assembly

Figure 30-60-15

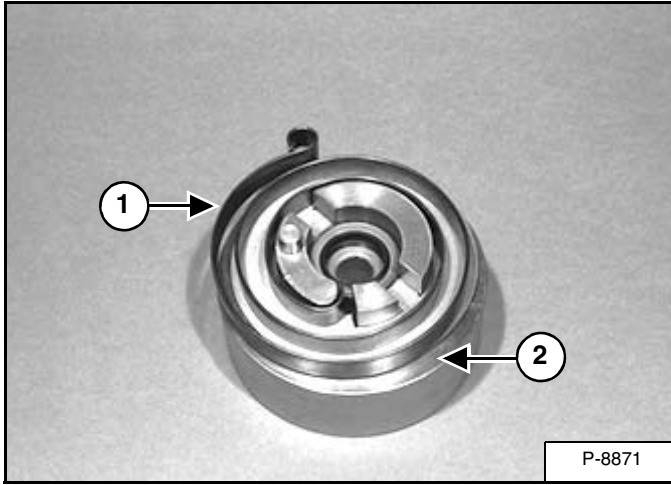

Install the spring (Item 1) on the pulley (Item 2) [Figure 30-60-15] as shown.

Figure 30-60-16

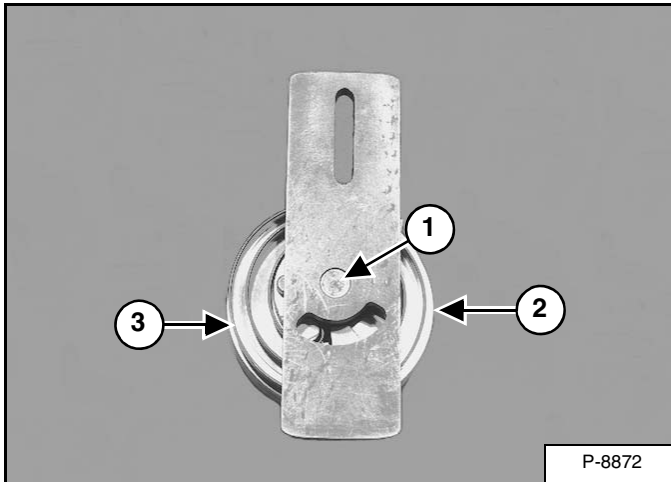

Install the shaft from the bracket assembly (Item 1) into the pulley assembly (Item 2) and align the spring (Item 3) [Figure 30-60-16] over the alignment pin on the bracket.

Figure 30-60-17

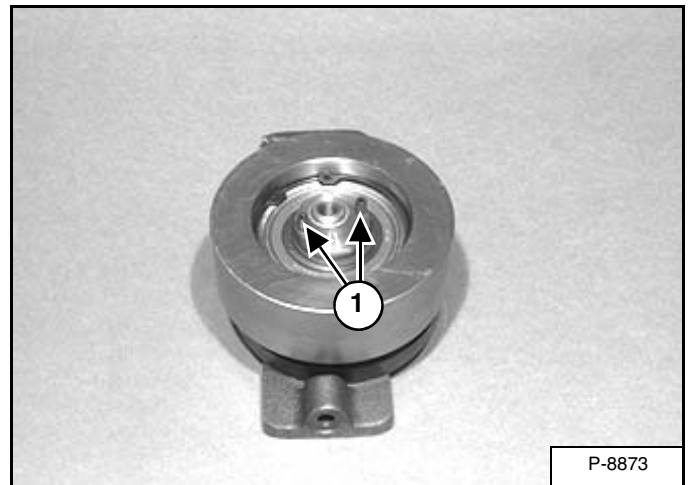

Turn the pulley assembly over and install the two pins (Item 1) [Figure 30-60-17] into the hub.

Figure 30-60-18

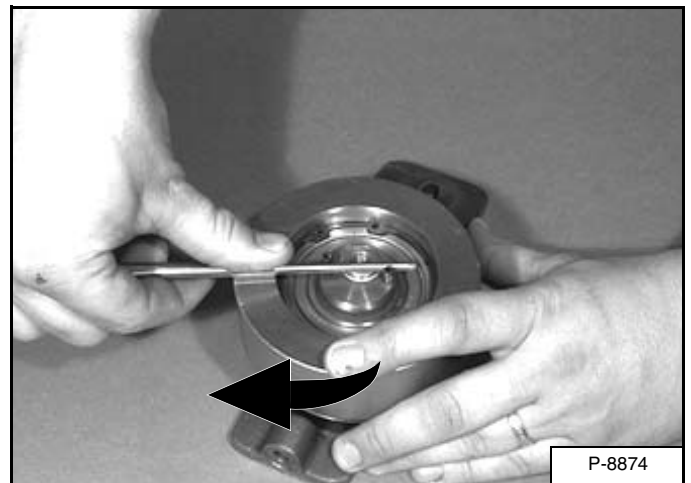

Install a punch as shown and turn clockwise while applying down pressure on the pulley.

Turn until the pulley snaps down into place; this procedure winds the spring and retains the end of the spring in proper location [Figure 30-60-18].

DRIVE SYSTEM

BRAKE (SINGLE SPEED)	40-10-1
Description	40-10-1
Disc Removal And Installation	40-10-1
BRAKE (TWO-SPEED)	40-11-1
Description	40-11-1
Disc Disassembly and Assembly	40-11-2
Disc Removal And Installation	40-11-1
CHAINCASE	40-30-1
Center Cover Removal And Installation	40-30-2
Description	40-30-1
Front Cover Removal And Installation	40-30-1
Rear Cover Removal And Installation	40-30-3
DRIVE COMPONENTS.	40-20-1
Axle Seal Removal And Installation	40-20-2
Axle Sprocket And Bearings Removal And Installation	40-20-4
Chain Removal And Installation	40-20-9
Description	40-20-1

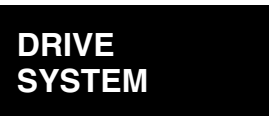

TIGHTEN ALL HARDWARE PER SIZE TO GRADE 5 TORQUE (SEE STANDARD TORQUE SPECIFICATIONS FOR BOLTS, SECTION SPEC-01) UNLESS OTHERWISE SPECIFIED.

SPECIFICATIONS SUBJECT TO CHANGE WITHOUT NOTICE AND STANDARD ITEMS MAY VARY.

CLICK HERE TO **DOWNLOAD** THE COMPLETE MANUAL

- Thank you very much for reading the preview of the manual.
- You can download the complete manual from: www.heydownloads.com by clicking the link below



- Please note: If there is no response to CLICKING the link, please download this PDF first and then click on it.

CLICK HERE TO **DOWNLOAD** THE COMPLETE MANUAL

DRIVE COMPONENTS (CONT'D)

Axle Sprocket And Bearings Removal And Installation (Cont'd)

Figure 40-20-8

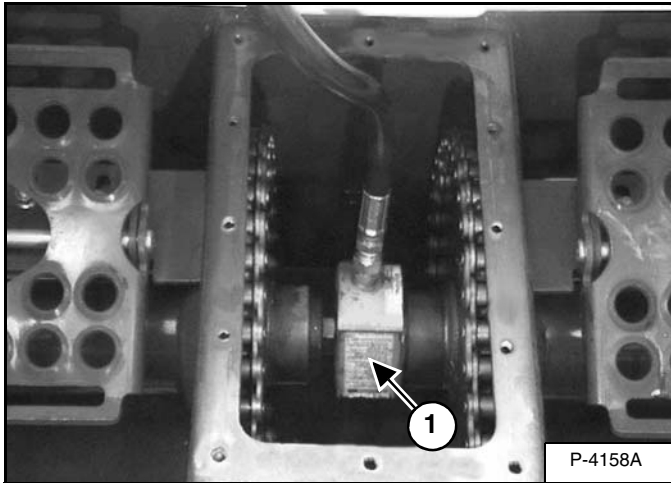

Install the MEL1242 power ram (Item 1) [Figure 40-20-8] between the two sprockets.

Put a spacer between the power ram and axle. Push the axle out to the end of the power ram stroke. Add another spacer and push the axle again. Repeat this procedure until the axle is free from the sprocket and inner bearing.

Figure 40-20-9

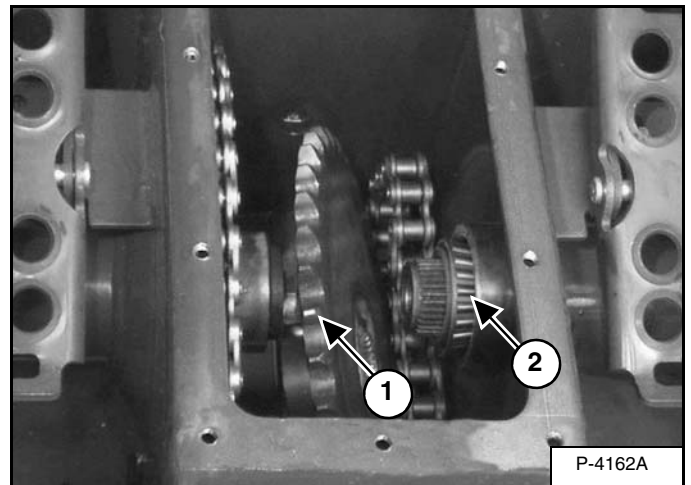

Remove the drive chain from the sprocket (Item 1) [Figure 40-20-9] and remove the sprocket from the chaincase.

Remove the inner bearing (Item 2) [Figure 40-20-9] and remove the axle from the axle tube. (See Axle Sprocket And Bearings Removal And Installation on Page 40-20-4.)

Installation: Pack both axle bearings with grease before installing them.

Figure 40-20-10

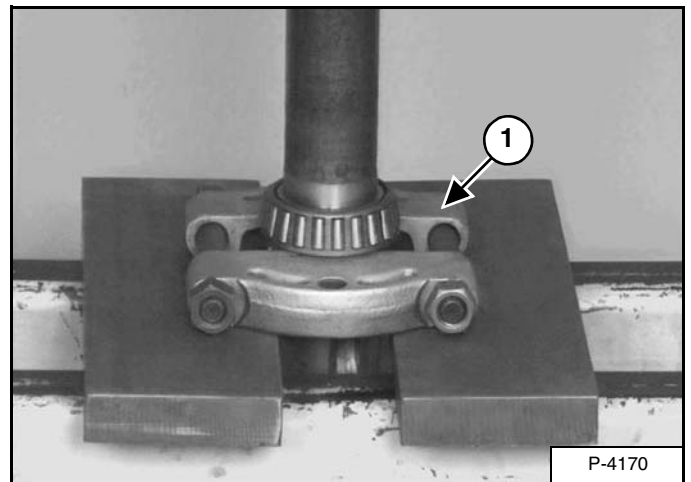

A bearing puller (Item 1) [Figure 40-20-10] is needed for the following procedure:

Put the axle/outer bearing assembly in the bearing puller as shown and put in the hydraulic press [Figure 40-20-10].

MAIN FRAME

ACCESS PANEL (INSIDE)	50-120-1
Removal And Installation (Left)	50-120-1
Removal And Installation (Right)	50-120-1
ACCESS PANEL (INSIDE) (SJC)	50-121-1
Removal And Installation (Left)	50-121-1
Removal And Installation (Right)	50-121-2
BOB-TACH (HAND LEVER)	50-40-1
Description	50-40-1
Lever And Wedge Disassembly And Assembly	50-40-2
Pivot Pin Bushing And Seal Removal And Installation	50-40-4
Removal And Installation	50-40-1
BOB-TACH (POWER-OPTION)	50-41-1
Description	50-41-1
Lever And Wedge Disassembly And Assembly	50-41-3
Pivot Pin Bushing And Seal Removal And Installation	50-41-4
Removal And Installation	50-41-1
CONTROL HANDLE/LEVER	50-110-1
Boot Removal And Installation	50-110-2
Description	50-110-1
Lever Removal And Installation	50-110-1
CONTROL HANDLE/LEVER (ACS)	50-111-1
Boot Removal And Installation	50-111-7
Description	50-111-1
Handle Disassembly and Assembly	50-111-5
Handle Removal and Installation	50-111-4
Handle Sensor Removal And Installation	50-111-1
Lever Removal and Installation	50-111-5
CONTROL HANDLE/LEVER (SJC)	50-112-1
Description	50-112-1
Joystick Testing	50-112-1
Joystick Removal And Installation (S/N 530111001 - 530113636, S/N 530211001 - 530212153, S/N 530311001 - 530315804, S/N 530411001 - 530411388)	50-112-2
Joystick Removal And Installation (S/N 530113637 & Above, S/N 530212154 & Above, S/N 530315805 & Above, S/N 530411389 & Above)	50-112-4
Removal And Installation (S/N 530111001 - 530113636, S/N 530211001 - 530212153, S/N 530311001 - 530315804, S/N 530411001 - 530411388)	50-112-5
Removal And Installation (S/N 530113637 & Above, S/N 530212154 & Above, S/N 530315805 & Above, S/N 530411389 & Above)	50-112-6



Continued On Next Page

OPERATOR SEAT (SUSPENSION) (CONT'D)

3-Point Seat Belt Removal And Installation

Raise the operator cab. (See Raising on Page 10-30-2.)

Remove the operator seat. (See Removal And Installation on Page 50-31-1.)

Figure 50-31-14

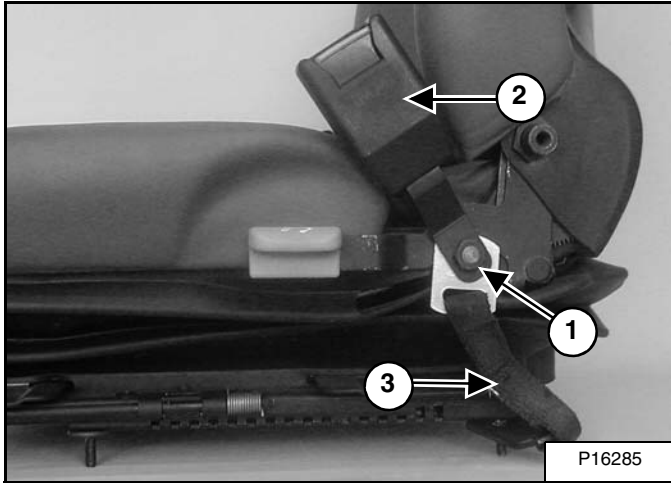

Remove the mounting nut (Item 1) [Figure 50-31-14]

Remove the end release buckle (Item 2) [Figure 50-31-14]

Installation: Be sure tether strap (Item 3) [Figure 50-31-14] is on the seat belt stud behind the end release buckle.

Figure 50-31-15

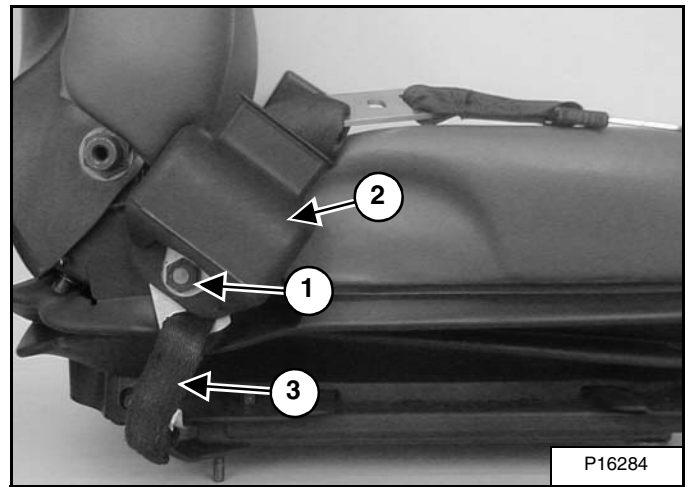

Remove the mounting nut (Item 1) [Figure 50-31-15]

Remove the seat belt retractor (Item 2) [Figure 50-31-15]

Installation: Be sure tether strap (Item 3) [Figure 50-31-15] is on the seat belt stud behind the seat belt retractor.

LIFT ARMS

Stabilizer Bar Removal And Installation

Figure 50-50-1

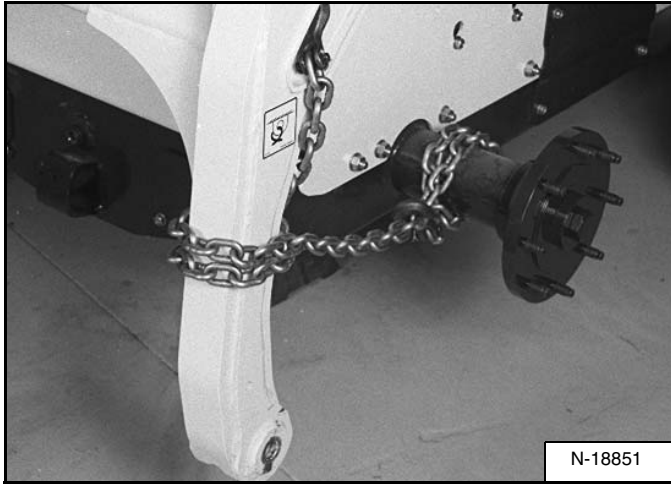

Lower the lift arms.

Raise the operator cab. (See Raising on Page 10-30-2.)

Connect a chain to the front of the lift arm and around the axle [Figure 50-50-1].

NOTE: The Bob-Tach and front wheel are removed in photo [Figure 50-50-1] for clarity purpose only. The Bob-Tach and front wheel do not need to be removed to remove the stabilizer link.

Figure 50-50-2

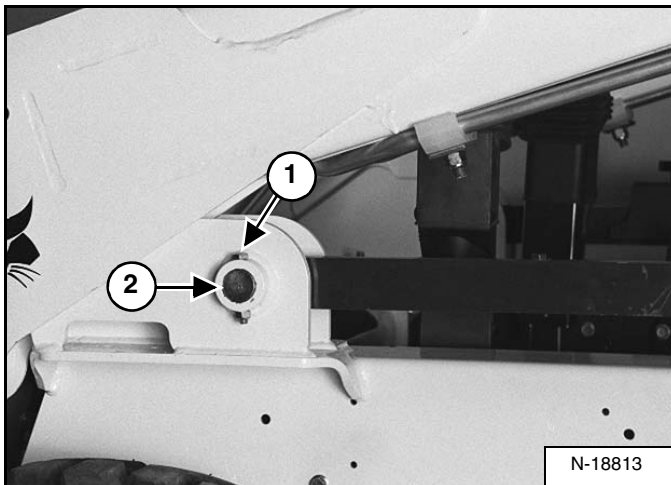

Remove the retainer bolt (Item 1) [Figure 50-50-2] from the stabilizer link pivot pin.

Remove the stabilizer link pivot pin (Item 2) [Figure 50-50-2].

Figure 50-50-3

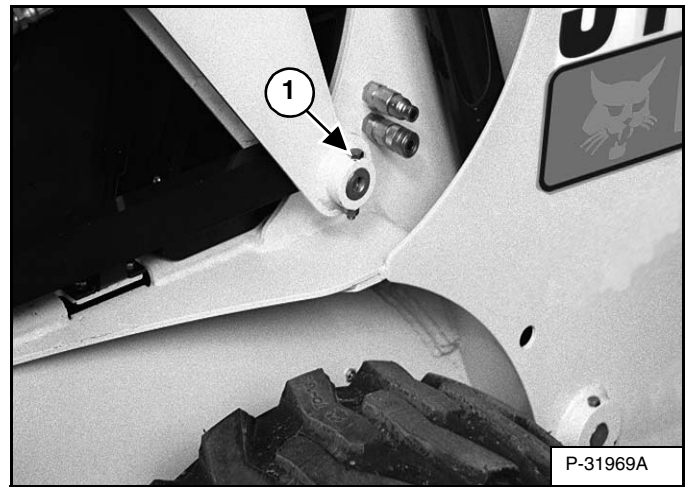

Remove the retainer bolt (Item 1) [Figure 50-50-3] from the stabilizer link pivot pin.

Figure 50-50-4

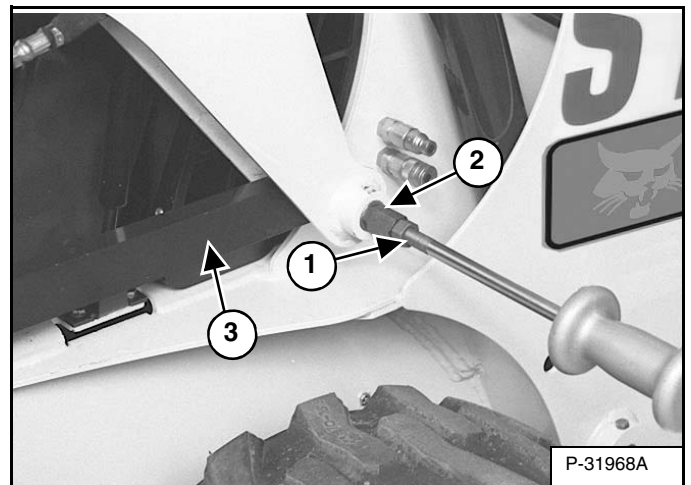

Use a slide hammer (Item 1), remove the stabilizer link pivot pin (Item 2) [Figure 50-50-4].

Remove the stabilizer link (Item 3) [Figure 50-50-4] from the lift arm.

Reverse the above procedure to install the stabilizer link.

REAR DOOR (CONT'D)

Latch Removal and Installation

Figure 50-70-7

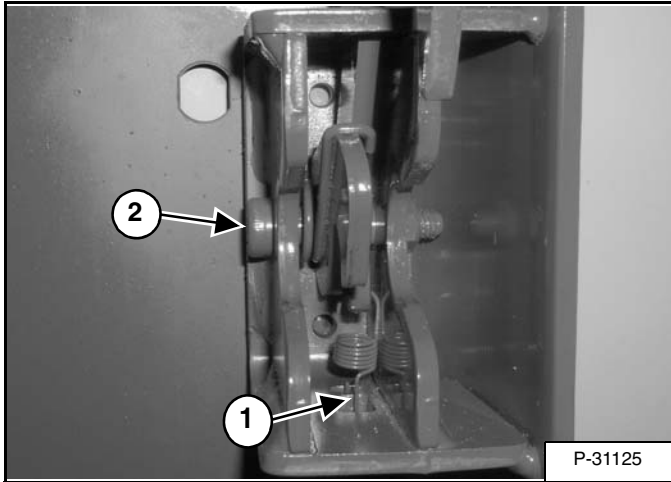

Disconnect the spring (Item 1) [Figure 50-70-7] from the rear door.

Remove the bolt and nut (Item 2) [Figure 50-70-7] from the latch.

Figure 50-70-8

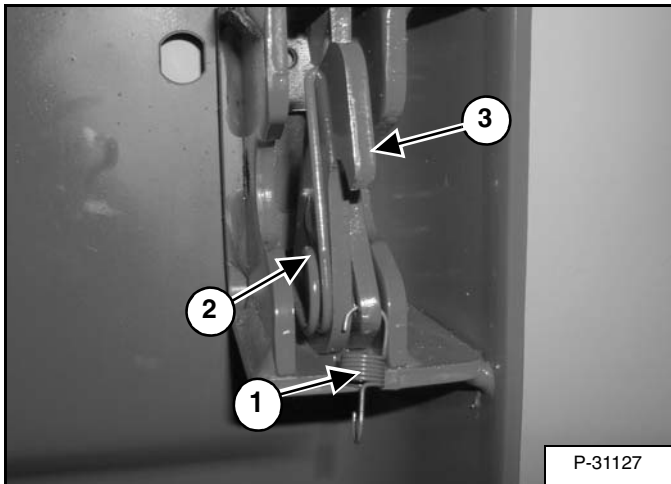

Remove the spring (Item 1) [Figure 50-70-8] from the door handle.

Remove the spring (Item 2) [Figure 50-70-8] from the door latch.

Remove the door latch (Item 3) [Figure 50-70-8] from the door handle.

Figure 50-70-9

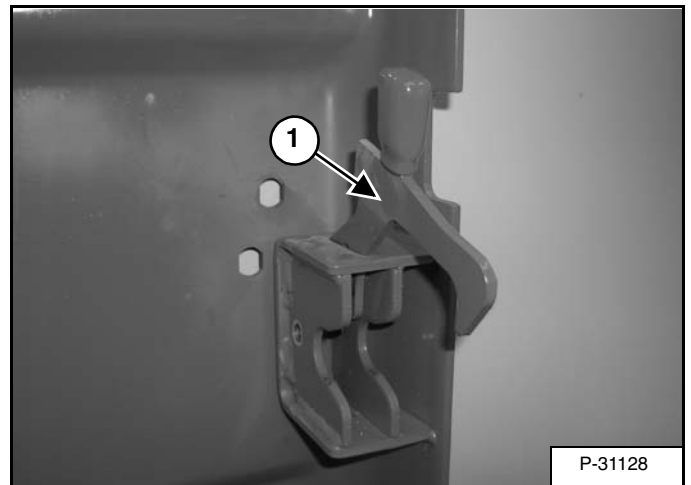

Remove the door handle (Item 1) [Figure 50-70-9] from the rear door.

CONTROL PEDALS (ACS)

Description

The control pedals send an electronic pulse to the actuators on the control valve. The electronic pulse tells the actuators to move the lift or tilt spools on the control valve.

The control pedals are located on the lower mainframe at the operators feet.

Foot Sensor Removal And Installation

Figure 50-91-1

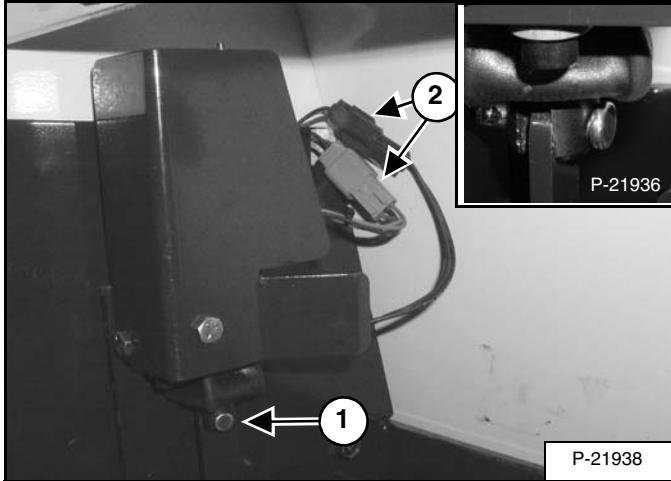

Pull the pin (Item 1) [Figure 50-91-1] holding the foot pedal linkage to the sensor.

Disconnect the two connectors (Item 2) [Figure 50-91-1] from the sensor and lock solenoid.

Figure 50-91-2

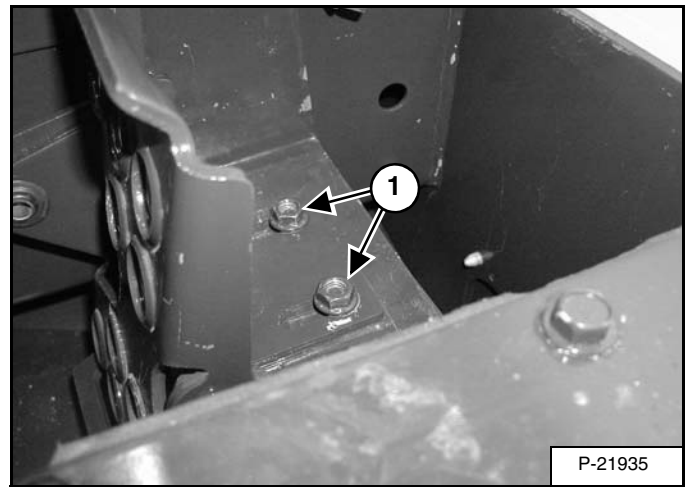

Tilt the foot pedal up and remove the two nuts (Item 1) [Figure 50-91-2].

Remove the foot pedal and sensor assembly from the loader.

Figure 50-91-3

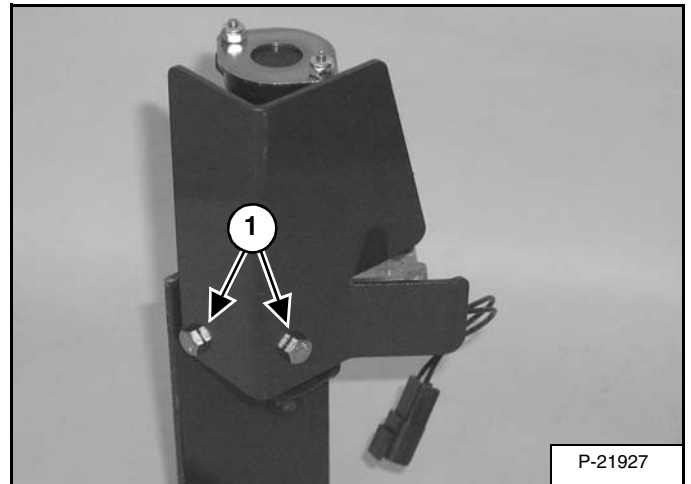

Remove the two bolts (Item 1) [Figure 50-91-3] from the foot sensor shield.

Installation: Tighten the bolts to 80 - 90 in.-lb. (9,0 - 10,2 N•m) torque.

CONTROL PANEL (CONT'D)

Linkage Removal And Installation

! WARNING

Never work on a machine with the lift arms up unless the lift arms are secured by an approved lift arm support device. Failure to use an approved lift arm support device can allow the lift arms or attachment to fall and cause injury or death.

W-2059-0598

! WARNING

Put jackstands under the front axles and rear corners of the frame before running the engine for service. Failure to use jackstands can allow the machine to fall or move and cause injury or death.

W-2017-0286

Raise the lift arms and install an approved lift arm support device. (See Installing on Page 10-20-1.)

Lift and block the loader. (See Procedure on Page 10-10-1.)

Figure 50-100-14

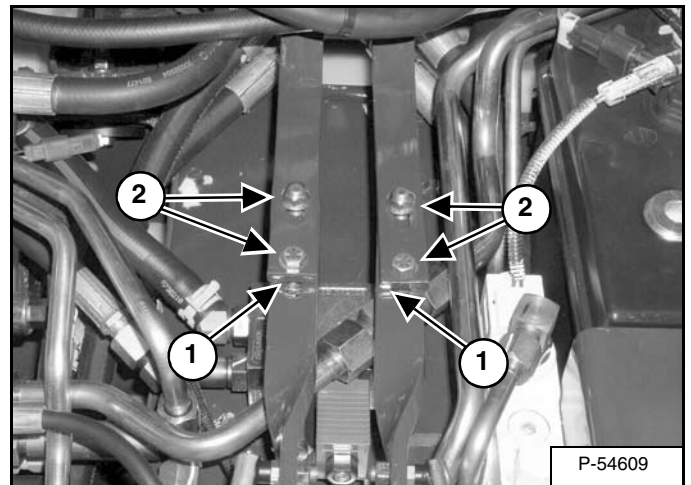

Scribe a mark across the top of the steering linkage bars (Item 1) [Figure 50-100-14] which are connected to the steering shaft on the control panel.

Remove the four steering linkage mounting bolts (Item 2) [Figure 50-100-14].

Installation: Align the marks on the steering linkage bars. Tighten the steering linkage mounting bolts to 35 - 40 ft.-lb. (47,5 - 54,2 N•m) torque.

NOTE: After removal and installation of the linkage, the linkage neutral adjustment procedure must be performed. See Page 50-100-13 for Linkage Neutral Adjustment procedure.

CONTROL PANEL (CONT'D)

Linkage Travel Adjustment

NOTE: When the linkage travel adjustment procedure is being done as part of the loader neutral adjustment procedure, check the torsion bushings at the pump and at the bell cranks to be sure they are not binding or too loose, which will affect the procedure.

WARNING

Never work on a machine with the lift arms up unless the lift arms are secured by an approved lift arm support device. Failure to use an approved lift arm support device can allow the lift arms or attachment to fall and cause injury or death.

W-2059-0598

Raise the lift arms and install an approved lift arm support device. (See Installing on Page 10-20-1.)

WARNING

Put jackstands under the front axles and rear corners of the frame before running the engine for service. Failure to use jackstands can allow the machine to fall or move and cause injury or death.

W-2017-0286

Lift and block the loader. (See Procedure on Page 10-10-1.)

Raise the operator cab. (See Raising on Page 10-30-2.)

Pre-load tension in the torsion bushings must be removed before adjusting the steering linkage.

Figure 50-100-37

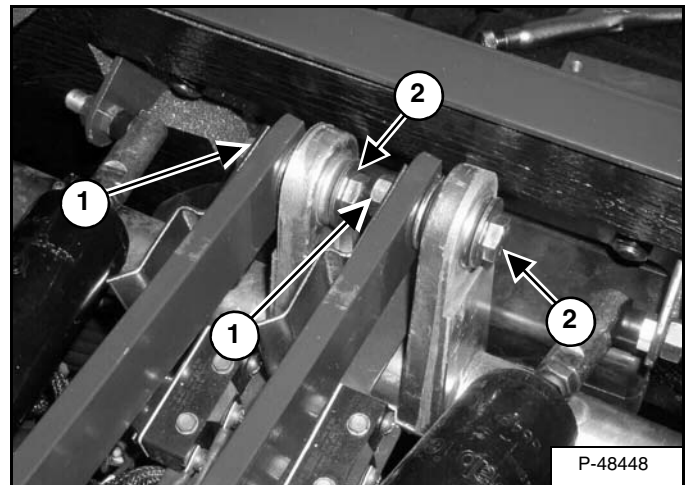

Loosen the nut (Item 1) 3 to 4 turns, then loosen the bolt (Item 2). The bolt (Item 2) [Figure 50-100-37] must be loosened enough to allow the torsion bushing to turn freely between the steering bellcrank and the linkage bar.

Figure 50-100-38

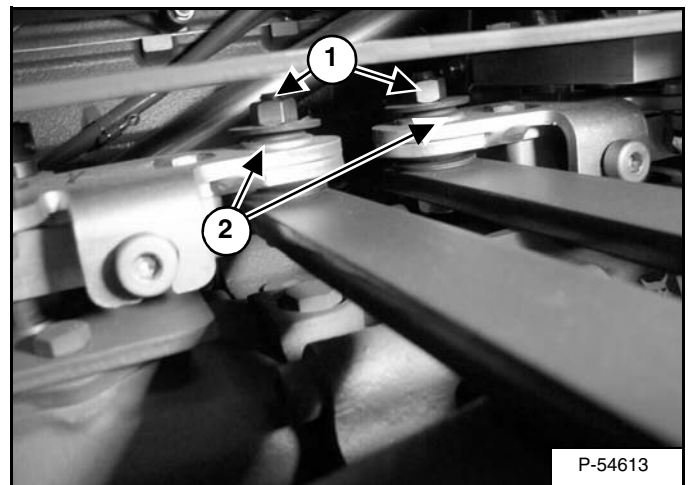

Loosen the nut (Item 1) only until the tension is released from the torsion bushing (Item 2) [Figure 50-100-38].

The bolt must be loose enough to allow the torsion bushing (Item 2) [Figure 50-100-38] to turn freely between the torsion bushing and the linkage bar.

CONTROL HANDLE/LEVER (ACS) (CONT'D)

Handle Sensor Removal And Installation (Cont'd)

Figure 50-111-8

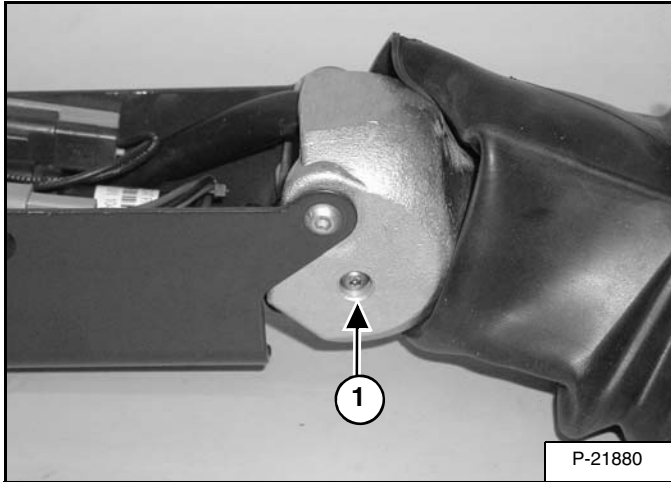

Remove one of the two mounting screws (Item 1) [Figure 50-111-8] from the handle sensor.

Installation: Tighten bolt to 32 - 38 in.-lb. (3,6 - 4,3 N•m) torque.

Figure 50-111-9

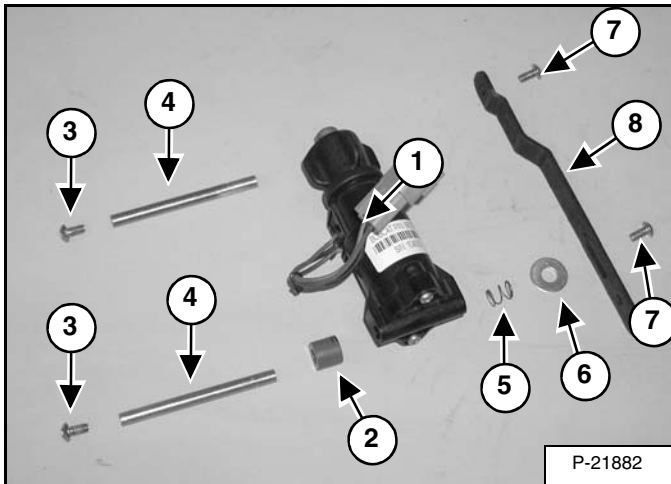

Remove the handle sensor (Item 1) [Figure 50-111-9] from the handle assembly.

NOTE: The handle sensor (Item 1) [Figure 50-111-9] can only be replaced as a complete assembly.

Check the spacer (Item 2) and screws (Item 3), mounting pin (Item 4), spring (Item 5), washer (Item 6), bolt/nut (Item 7), stop strap (Item 8) and replace as needed [Figure 50-111-9].

Figure 50-111-10

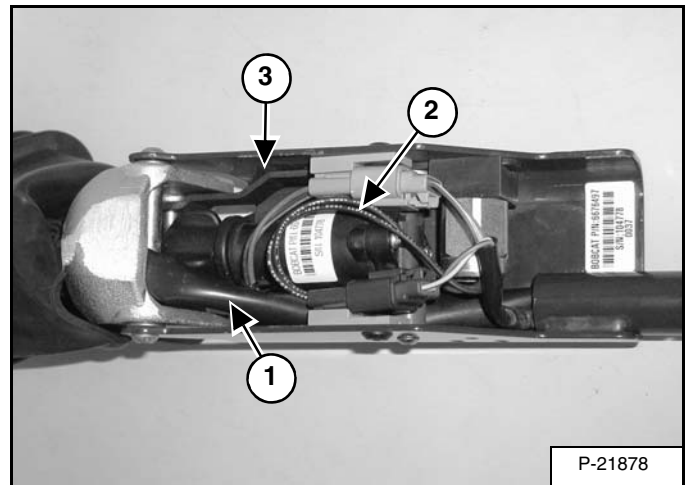
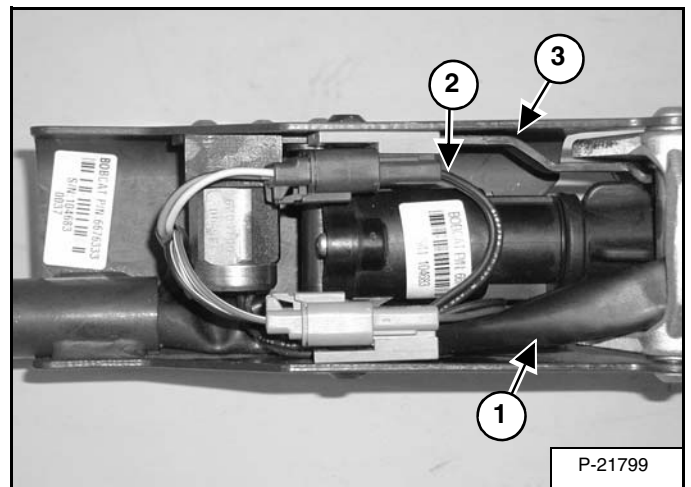

Figure 50-111-11



Installation: When installing the handle sensor into the control handle, check the routing of the switch handle wire harness (Item 1) [Figure 50-111-10] & [Figure 50-111-11] to assure proper return of the control handle to neutral and minimize harness movement.

NOTE: Route wires (Item 2) [Figure 50-111-10] & [Figure 50-111-11] as shown away from stop strap (Item 3) [Figure 50-111-10] & [Figure 50-111-11] to avoid wire damage.

NOTE: The calibration procedure must be followed when replacing handle sensor, foot pedal sensor, actuator or ACS Controller. (See Lift And Tilt Calibration (ACS) on Page 60-160-3.)

CONTROL HANDLE/LEVER (SJC) (CONT'D)

Removal And Installation (S/N 530111001 - 530113636, S/N 530211001 - 530212153, S/N 530311001 - 530315804, S/N 530411001 - 530411388)

Raise the lift arms and install an approved lift arm support device. (See Installing on Page 10-20-1.)

Raise the operator cab. (See Raising on Page 10-30-2.)

Figure 50-112-13

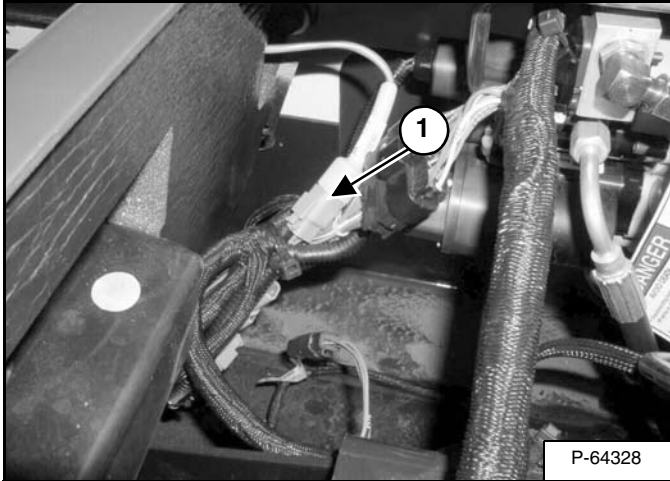

Disconnect the joystick wiring harness connectors (Item 1) on both the right and left hand joysticks [Figure 50-112-13].

Figure 50-112-14

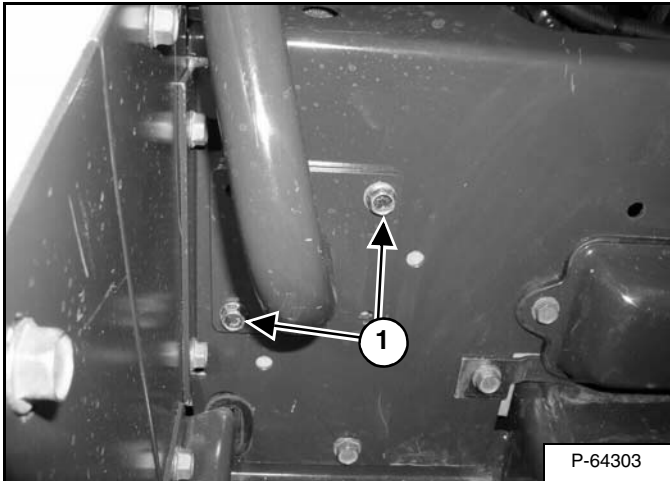

Remove the two control lever mounting bolts (Item 1) [Figure 50-112-14].

The mounting bolts are secured with lock-nuts on the back of the control panel. Once removed, they need to be replaced with new.

Figure 50-112-15



Remove the control lever from the loader [Figure 50-112-15].

WINDOW (TOP)

Removal And Installation

Figure 50-131-1

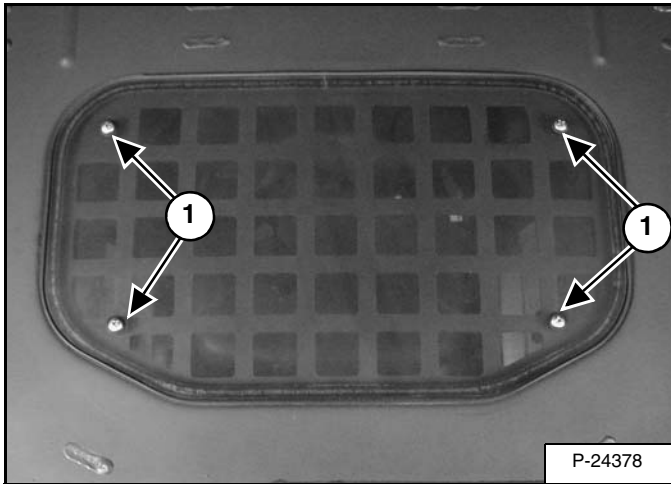

Position the window in the recess area.

Install the bolts (Item 1) [Figure 50-131-1] through the window grommets, the nylon bushings and through the cab holes.

Figure 50-131-2

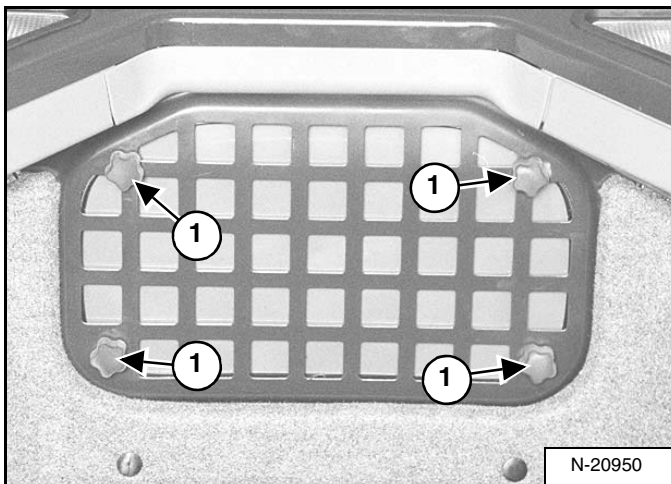

From inside the operator cab, install and tighten the knobs (Item 1) [Figure 50-131-2] on the window bolts.

ELECTRICAL SYSTEM (CONT'D)

FLYWHEEL RPM SENSOR	60-170-1
Adjusting	60-170-1
Description	60-170-1
INSTRUMENT PANELS	60-50-1
Alarm Removal And Installation	60-50-11
Bulb Removal And Installation (Left Only)	60-50-9
Front Accessory Panel Removal And Installation	60-50-11
Key Switch Removal And Installation	60-50-10
Left Panel	60-50-1
Removal And Installation (Left And Right)	60-50-6
Right Panel (Keyless)	60-50-3
Right Panel (Key Switch)	60-50-2
Side And Front Panels	60-50-5
LIGHTS	60-60-1
Cab Light Removal And Installation	60-60-2
Front Removal And Installation	60-60-1
Rear Removal And Installation	60-60-2
MAINTENANCE CLOCK	60-200-1
Description	60-200-1
Reset	60-200-6
Setup	60-200-2
PASSWORD SETUP (IF EQUIPPED WITH KEYLESS START) ..	60-190-1
Changing The Owner And User Passwords	60-190-2
Password Description	60-190-1
Password Lockout Feature	60-190-3
SEAT BAR SENSOR	60-110-1
Bobcat Interlock Control System (BICS) Circuit Test	60-110-5
Description	60-110-1
Removal And Installation	60-110-3
Testing	60-110-2
Troubleshooting	60-110-1
SERVICE PC (LAPTOP COMPUTER)	60-150-1
Connecting Remote Start Tool	60-150-1
Connecting Remote Start Tool (Service Tool)	60-150-1
STARTER	60-40-1
Parts Identification	60-40-3
Removal And Installation	60-40-2
Testing	60-40-1

Continued On Next Page

WIRING SCHEMATIC

(AHC)

S175 (S/N 530212984 AND ABOVE)

(S/N A8M411001 - A8M459999)

(S/N A8NY11001 AND ABOVE)

(S/N A8NZ11001 - A8NZ59999)

S185 (S/N 530411798 - 530459999)

(S/N ABRT11001 - ABRT59999)

(PRINTED FEBRUARY 2008)

7138770

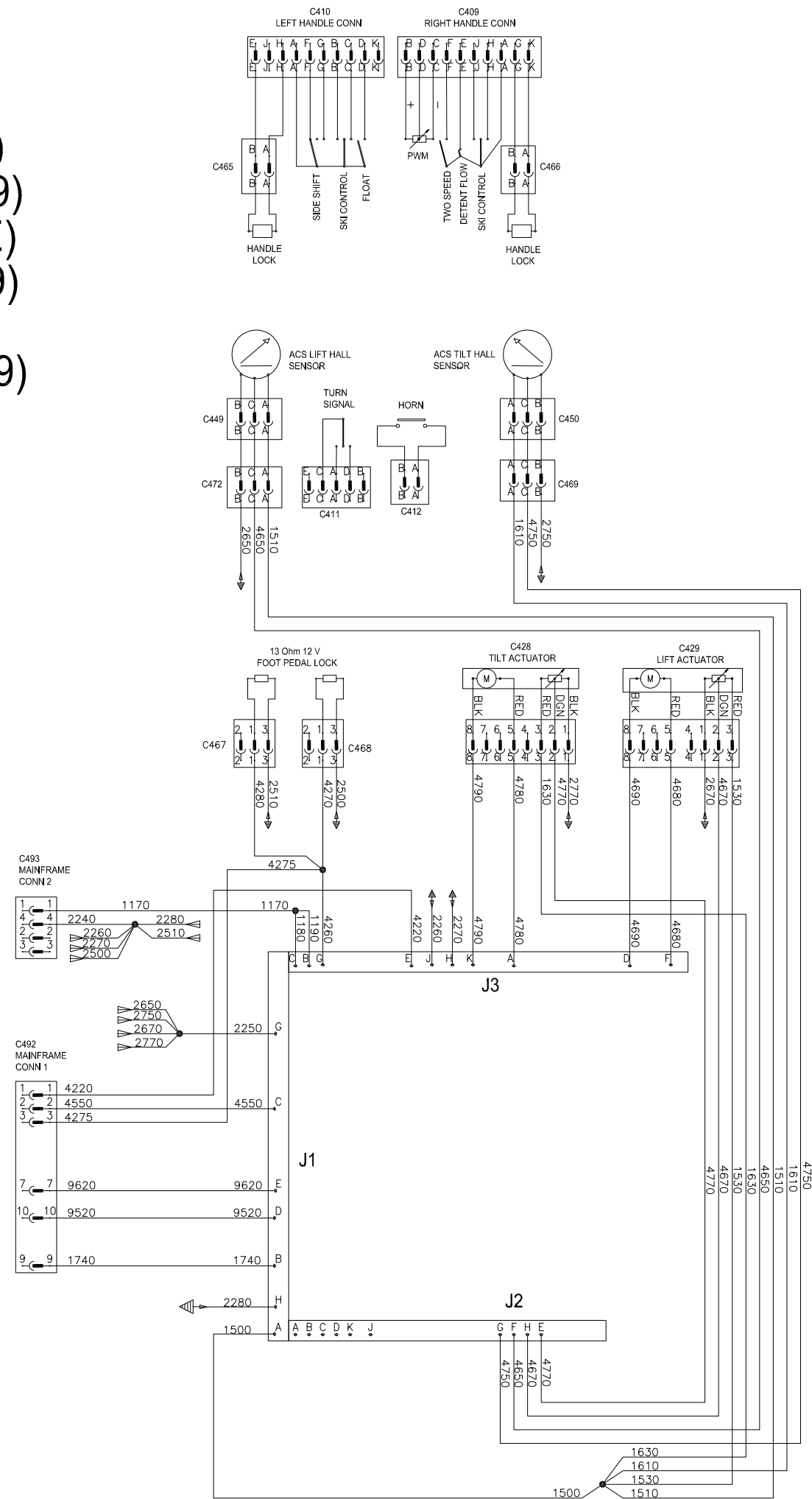

ELECTRICAL SYSTEM INFORMATION (CONT'D)

Description

Figure 60-10-1

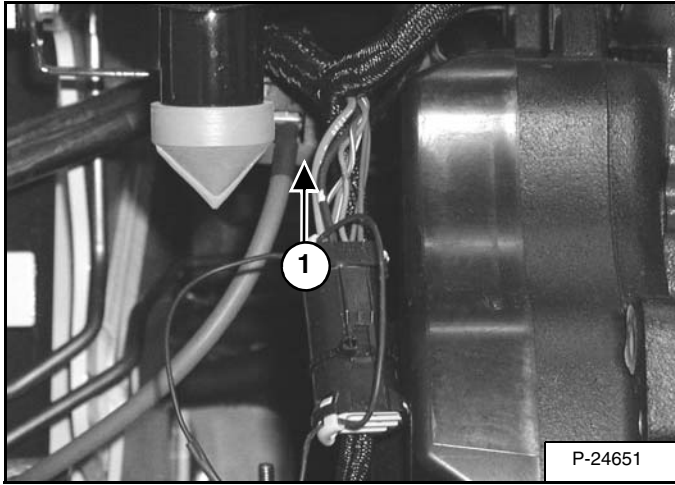
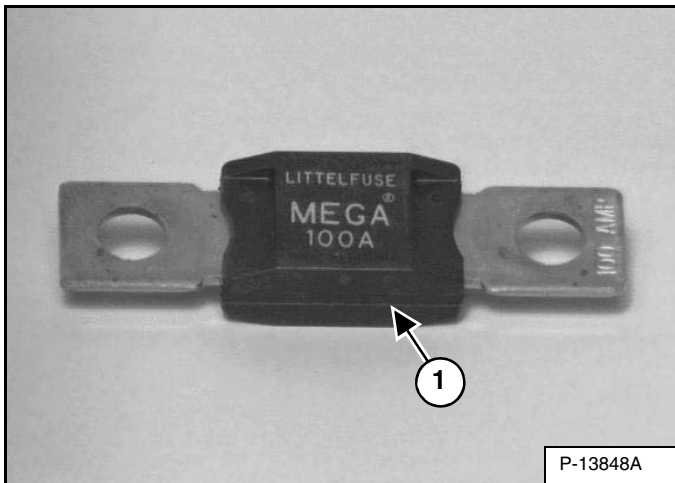
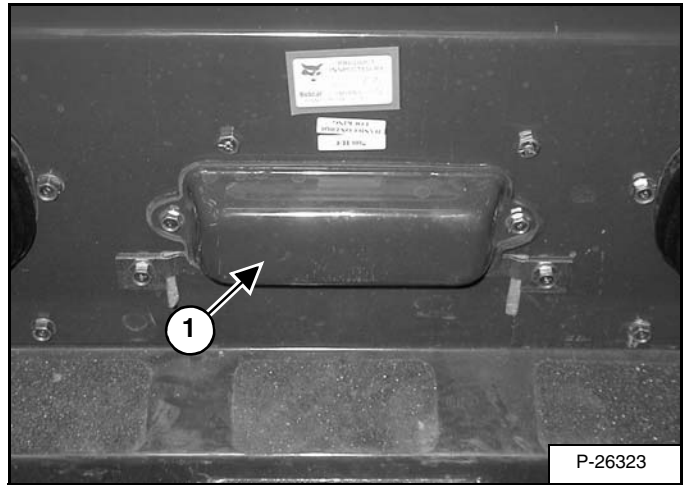

Figure 60-10-2



The loader has a 12 volt, negative ground alternator charging system. The electrical system is protected by a 100 amp master fuse (Item 1) [Figure 60-10-1] & [Figure 60-10-2] to protect against serious system overloads that could lead to burned up harness or loader damage. This fuse is located in the left-hand side engine compartment, just forward of the engine harness connector.

Figure 60-10-3



The electrical system is also protected by fuses and relays under the fuse panel cover (Item 1) [Figure 60-10-3] located in the cab on the control panel.

The fuse panel cover (Item 1) [Figure 60-10-3] has a decal inside to show the location and amp ratings.

IMPORTANT

Do Not use silicone base sprays and/or sealants on harness connectors or components.

I-2123-0397

ALTERNATOR (CONT'D)

Charging System Inspection

! WARNING

AVOID INJURY OR DEATH

Batteries contain acid which burns eyes and skin on contact. Wear goggles, protective clothing and rubber gloves to keep acid off body.

In case of acid contact, wash immediately with water. In case of eye contact get prompt medical attention and wash eye with clean, cool water for at least 15 minutes.

If electrolyte is taken internally drink large quantities of water or milk! DO NOT induce vomiting. Get prompt medical attention.

W-2065-0807

! WARNING

AVOID INJURY OR DEATH

Keep arcs, sparks flames and lighted tobacco away from batteries. When *jumping* from booster battery make final connection (negative) at machine frame.

Do not jump start or charge a frozen or damaged battery. Warm battery to 60°F (16°C) before connecting to a charger. Unplug charger before connecting or disconnecting cables to battery. Never lean over battery while boosting, testing or charging.

Battery gas can explode and cause serious injury.

W-2066-0705

IMPORTANT

Damage to the alternator can occur if:

- Engine is operated with battery cables disconnected.
- Battery cables are connected when using a fast charger or when welding on the loader. (Remove both cables from the battery.)
- Extra battery cables (booster cables) are connected wrong.

I-2023-1285

Figure 60-30-2

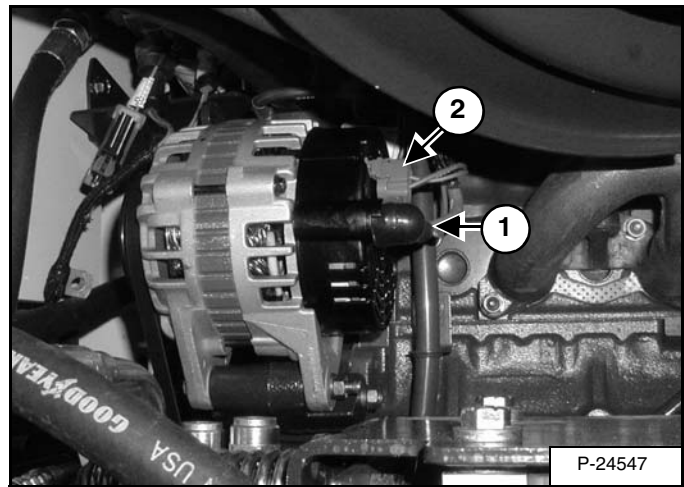

If the charging system malfunctions check the following:

Check the condition and tension of the alternator belt. (See Belt Adjustment on Page 60-30-1.) If belt is worn or deteriorated replace.

Inspect the alternator wiring harness and connectors at alternator. Harness and connectors must be clean and tight.

Check the fuse for the alternator in the fuse panel. If fuse is burned, find the cause and repair/replace. If fuse is in doubt, remove it and check for continuity.

Check the electrolyte level in the battery. Add distilled water as needed. (Does not apply to maintenance free batteries.)

Verify the charge of the battery. Make sure battery is fully charged.

Disconnect the battery cables (negative first, then positive). Inspect the cable clamps and battery posts for corrosion. Remove acid or corrosion from the battery and cables with a sodium bicarbonate and water solution. Put grease on the cable ends and battery terminals to prevent corrosion. Reconnect the cable to the positive terminal.

With the key off, connect a test light between the negative battery post and the disconnected negative cable clamp.

1. If the test light does not light up, reattach the clamp and proceed to alternator voltage test. (See Below.)
2. If the test light lights up, there is a short (drain) in the electrical system of the loader. The short must be repaired before the charging system can be checked.
3. Disconnect the alternator B+ terminal (Item 1) and L & S terminal connector (Item 2) [Figure 60-30-2] and if the test light goes out, the alternator is faulty. If the test light stays on, find the short in the system and repair it.

INSTRUMENT PANELS (CONT'D)

Right Panel (Key Switch)

Figure 60-50-2

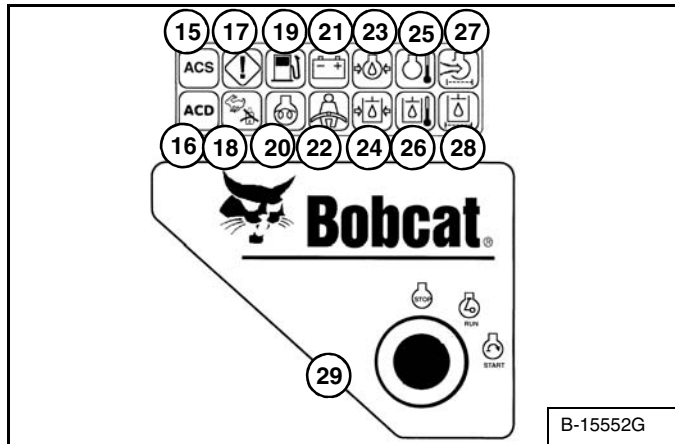

The right instrument panel shown [Figure 60-50-2] is the Key Switch Panel.

The table below shows the icons and other components of the Right Key Switch Panel.

REF.	FUNCTION	ICON/ LIGHT	ALARM	CODE	CONDITION	DESCRIPTION
15	Advanced Control System (ACS) (Opt.)	ON	3 Beeps	*	Error	Error with Advanced Control System (ACS) or Selectable Joystick Control (SJC)
16	Attachment Control Device (ACD)	ON FLASHING	3 Beeps	---	---	Electrical controlled attachment is present. Error with Attachment Control Device (ACD)
17	General Warning	ON ON FLASHING	3 Beeps 3 Beeps Continuous	*	Error WARNING SHUTDOWN	Error with one or more engine or hydraulic functions. Engine speed high or in shutdown. Engine speed very high. Engine will stop in 10 seconds.
18	Two-Speed (Opt.)	ON FLASHING FLASHING SLOWLY	---	-	---	High range selected. (Fasten shoulder belt.) Two-speed electrical error. Hydraulic fluid temperature below limit for two-speed operation.
19	Fuel Level	ON FLASHING	3 Beeps 3 Beeps	*	Error WARNING	Fuel level sender system fault. Fuel level low.
20	Engine Preheat	ON FLASHING	---	---	---	Glow plugs are energized. Error with glow plugs
21	System Voltage	ON	3 Beeps	*	WARNING	Voltage low, high or very high.
22	Seat Belt	ON	---	---	---	Light stays on for 45 seconds to remind operator to fasten seat belt.
23	Engine Oil Pressure	ON ON FLASHING	3 Beeps 3 Beeps Continuous	*	Error WARNING SHUTDOWN	Engine oil pressure sender out of range. Engine oil level low. Engine oil pressure very low. Engine will shutdown in 10 seconds.
24	Hydrostatic Charge Pressure	ON ON FLASHING	3 Beeps 3 Beeps Continuous	*	Error WARNING SHUTDOWN	Hydraulic oil pressure sender out of range. Hydraulic oil pressure low. Hydraulic charge pressure very low. Engine will stop in 10 seconds.
25	Engine Coolant Temperature	ON ON FLASHING	3 Beeps 3 Beeps Continuous	*	Error WARNING SHUTDOWN	Engine coolant sender out of range Engine coolant temperature high. Engine coolant temperature very high. Engine will stop in 10 seconds.
26	Hydraulic Oil Temperature	ON ON FLASHING	3 Beeps 3 Beeps Continuous	*	Error WARNING SHUTDOWN	Hydraulic oil temperature out of range. Hydraulic oil temperature high. Hydraulic oil temperature very high. Engine will stop in 10 seconds.
27	Engine Air Filter	ON FLASHING	3 Beeps 3 Beeps	*	Error WARNING	Air filter with high restriction. Air filter switch not connected.
28	Hydraulic Filter	ON FLASHING	3 Beeps 3 Beeps	*	Error WARNING	Hydraulic filter with high restriction. Hydraulic filter switch not connected.
29	Key Switch	---	---	---	---	Used to start and stop the engine.

* These functions are monitored and have associated SERVICE CODES. See SYSTEM SETUP AND ANALYSIS for description of SERVICE CODES.



Bobcat®

BOBCAT CONTROLLER (ACS) (CONT'D)

Removal and Installation

Figure 60-71-6

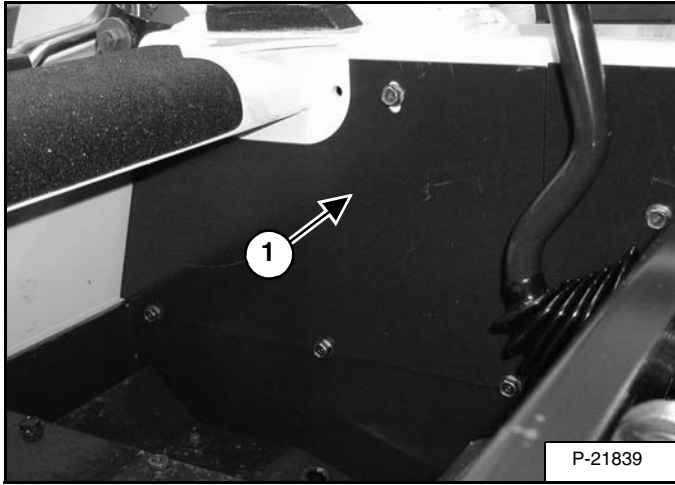

Loosen the bottom bolts and remove the top bolt on the right front panel [Figure 60-71-6].

Remove the right front panel (Item 1) [Figure 60-71-6] from the loader.

Figure 60-71-7

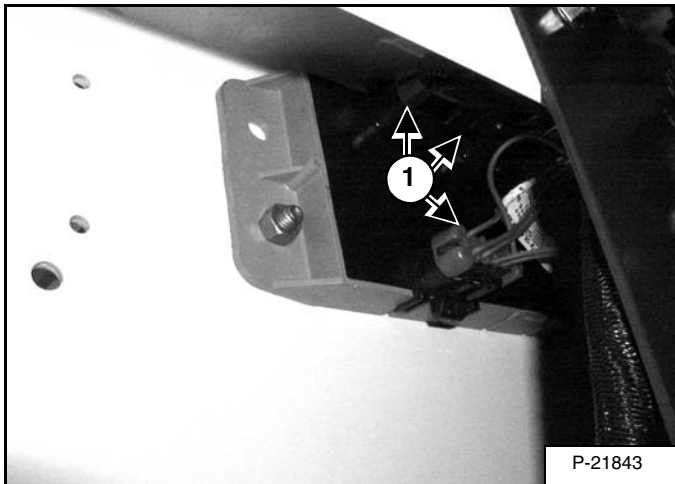

Disconnect the wiring harness connectors (Item 1) [Figure 60-71-7] from the controller.

Figure 60-71-8

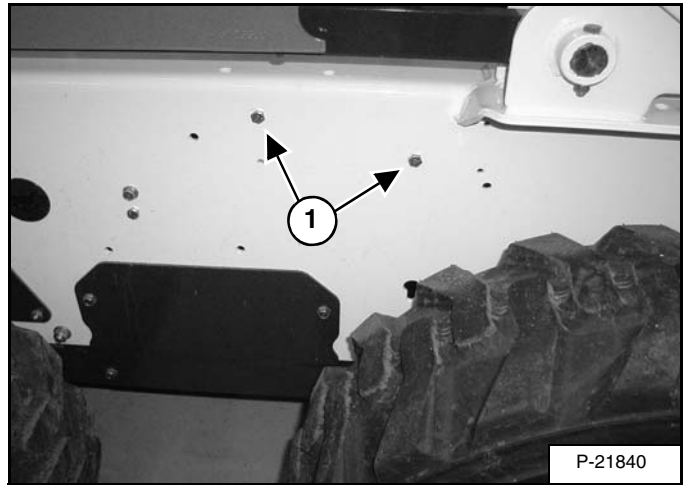

Remove the two mounting bolts (Item 1) [Figure 60-71-8] from the controller.

Remove the controller from the loader.

NOTE: The calibration procedure must be followed when replacing handle sensor, foot pedal sensor, actuator or ACS Controller. (See CALIBRATION on Page 60-160-1.)

WHEEL SPEED SENSORS (SJC) (CONT'D)

Removal and Installation (Cont'd)

Figure 60-80-9

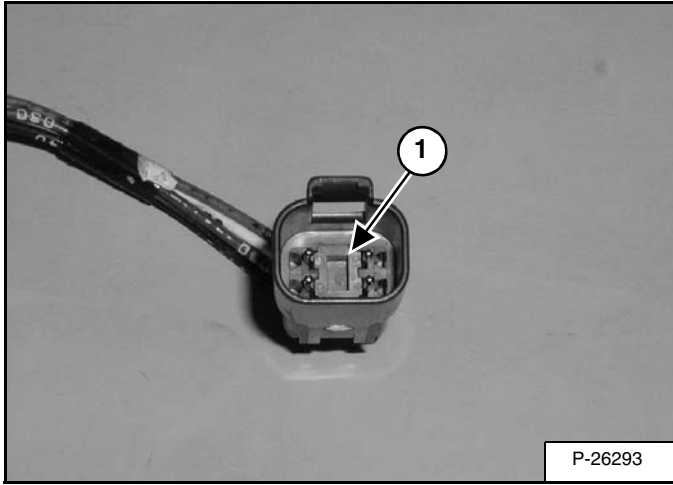

The electrical connector can be replaced.

Remove the connector wedge (Item 1) [Figure 60-80-9].

Figure 60-80-10

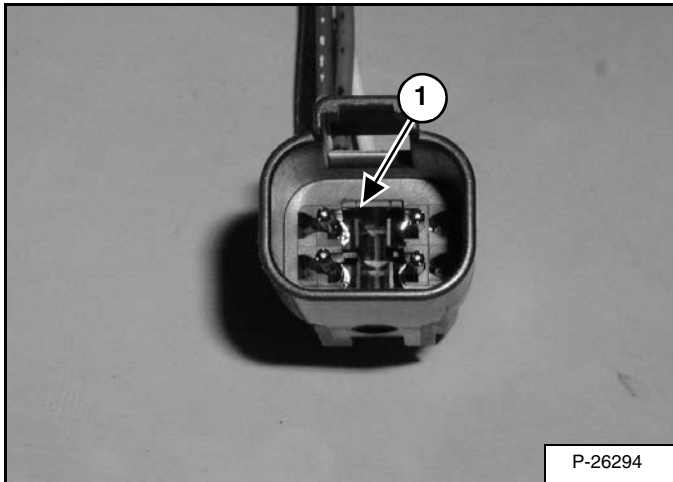

With a thin screwdriver lift the tabs and remove the wires from the connector (Item 1) [Figure 60-80-10].

Wire Code

- 1 Red
- 2 White
- 3 Black
- 4 Blue

Figure 60-80-11

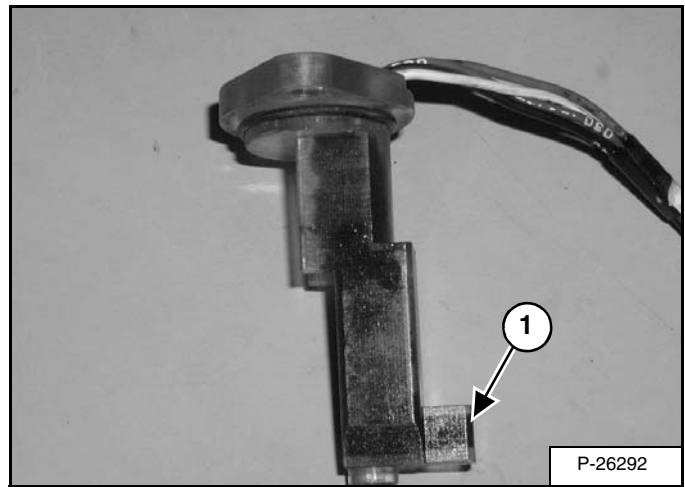

Installation: Be sure to install the speed sensor (Item 1) [Figure 60-80-11] pointing toward the transmission case.

Figure 60-80-12

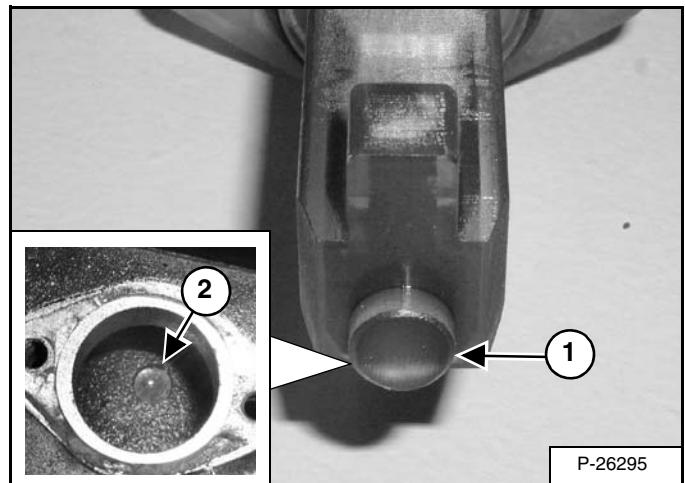

Installation: The alignment pin (Item 1) at the bottom of the speed sensor must be installed in the hole (Item 2) [Figure 60-80-12] in the motor carrier.

BOBCAT INTERLOCK CONTROL SYSTEM (BICS) (CONT'D)

Inspecting The BICS Controller (Engine STOPPED - Key ON)

Figure 60-100-2

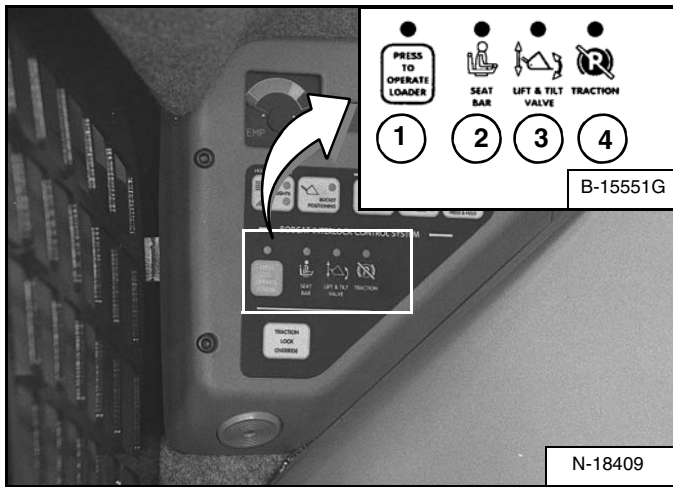

1. Sit in operator's seat. Turn key ON. (Standard Panel), press RUN/ENTER Button (Deluxe Panel), lower seat bar and disengage parking brake. Press the PRESS TO OPERATE LOADER Button. Three BICS lights (Items 1, 2 & 3) [PRESS TO OPERATE LOADER, SEAT BAR, AND LIFT & TILT VALVE] on left instrument panel should be ON [Figure 60-100-2].
2. Raise seat bar fully. All four BICS lights (Items 1, 2, 3, and 4) [PRESS TO OPERATE LOADER, SEAT BAR, LIFT & TILT VALVE AND TRACTION*] on left instrument panel should be OFF [Figure 60-100-2].

NOTE: Record what lights are blinking (if any) and the number of light flashes. (See Troubleshooting on Page 60-100-3.)

Inspecting Deactivation Of The Auxiliary Hydraulics System (Engine STOPPED - Key ON)

3. Sit in operator's seat, lower seat bar, and press the PRESS TO OPERATE LOADER Button. Press the auxiliary hydraulics FLOW Button. The auxiliary FLOW Button light will come ON. Raise the seat bar. The light should be OFF.

Inspecting The Seat Bar Sensor (Engine RUNNING)

4. Sit in operator's seat, lower seat bar, engage parking brake and fasten seat belt.
5. Start engine and operate at low idle. Press the PRESS TO OPERATE LOADER Button. While raising the lift arms, raise the seat bar fully. The lift arms should stop. Repeat using the tilt function.

Inspecting The Traction Lock (Engine RUNNING)

6. Fasten seat belt, disengage parking brake, press the PRESS TO OPERATE LOADER Button and raise seat bar fully. Move steering levers slowly forward and backward. The TRACTION lock should be engaged. Lower the seat bar. Press the PRESS TO OPERATE LOADER Button.
7. Engage parking brake and move steering levers slowly forward and backward. The TRACTION lock should be engaged.

NOTE: *The TRACTION light on the left instrument panel will remain OFF until the engine is started, the PRESS TO OPERATE LOADER Button is pressed and the parking brake is disengaged.

Inspecting The Lift Arm Bypass Control

8. Raise the lift arms 6 feet (2 meters) off the ground. Stop engine. Turn lift arm bypass control knob clockwise 1/4 turn. Pull up and hold lift arm bypass control knob until lift arms slowly lower.

Inspecting Deactivation Of Lift And Tilt Functions (ACS and SJC)

9. Sit in operator's seat and fasten seat belt. Lower seat bar, start engine and press the PRESS TO OPERATE LOADER Button.
10. Raise lift arms about 6 feet (2 meters) off the ground.
11. Turn key OFF (Standard Panel), press STOP Button (Deluxe Panel), and wait for the engine to come to a complete stop.
12. Turn key ON (Standard Panel), press RUN/ENTER Button (Deluxe Panel). Press the PRESS TO OPERATE LOADER Button, move hand control or joystick to lower the lift arms. Lift arms should not lower.
13. Move the control (foot pedal, hand control or joystick) to tilt the bucket (or attachment) forward. The bucket (or attachment) should not tilt forward.

! WARNING

AVOID INJURY OR DEATH

The Bobcat Interlock Control System (BICS) must deactivate the lift, tilt and traction drive functions. If it does not, contact your dealer for service. DO NOT modify the system.

W-2151-0394

TRACTION LOCK (CONT'D)

Removal And Installation

! WARNING

AVOID INJURY OR DEATH

Do not modify the electrical wiring connected to the traction lock solenoid or any part of the traction lock system. The traction lock provides the locking function of the parking brake. Service work on the traction lock system should only be performed by a qualified technician. Use only genuine Bobcat Company parts if repair is necessary.

W-2165-0100

Raise the loader operator cab. (See Raising on Page 10-30-2.)

Figure 60-120-1

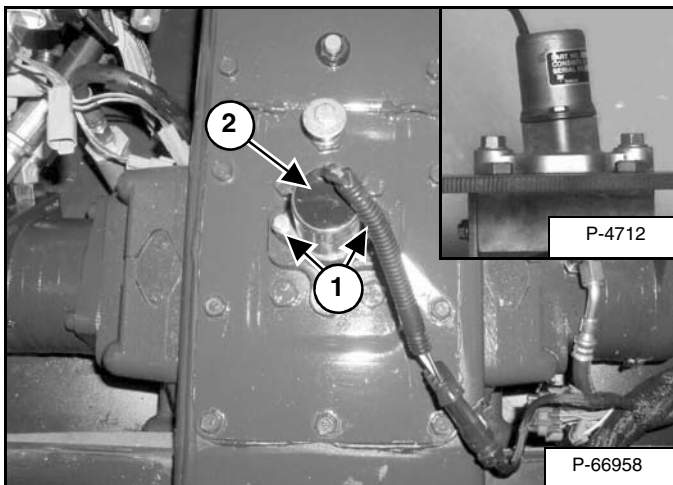

NOTE: The loader control panel and linkage crossbar have been removed for clarity purpose only. The traction lock can be removed without removing the control panel.

Remove the two mounting screws (Item 1) [Figure 60-120-1] from the electric solenoid mounting bracket.

Installation: Tighten the mounting screws to 80 - 90 in.-lb. (9 - 10 N•m) torque.

Remove the electric solenoid (Item 2) from the chaincase cover [Figure 60-120-1].

Figure 60-120-2

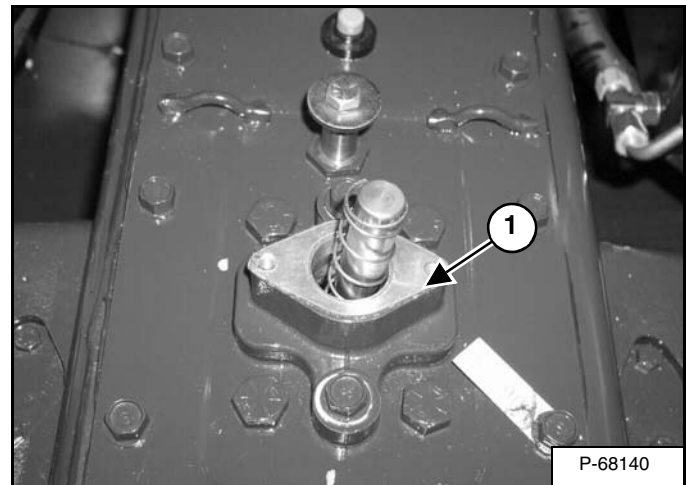

Remove the bracket (Item 1) [Figure 60-120-2] from the chaincase cover.

Installation: Apply polyurethane sealer to the bolt threads and tighten the mounting bolts to 25 - 28 ft.-lb. (34 - 38 N•m) torque.

Be sure the solenoid mounting bracket is installed in the same position. The solenoid mounting surface has a slight angle which tips the top of the solenoid toward the rear of the loader when installed correctly. See inset photo [Figure 60-120-1].

Figure 60-120-3

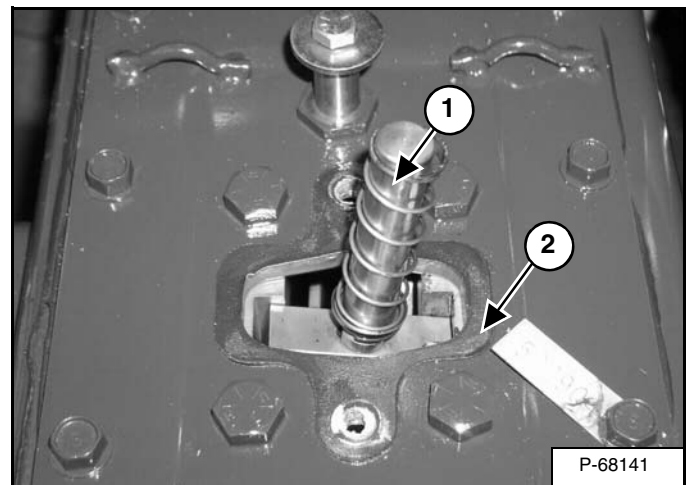

Remove the traction lock assembly (Item 1) [Figure 60-120-3] from the chaincase.

Inspect gasket (Item 2) [Figure 60-120-3], replace if necessary.

CONTROL SYSTEM (ACS) (CONT'D)

Switch Handle Removal (Cont'd)

Figure 60-130-12

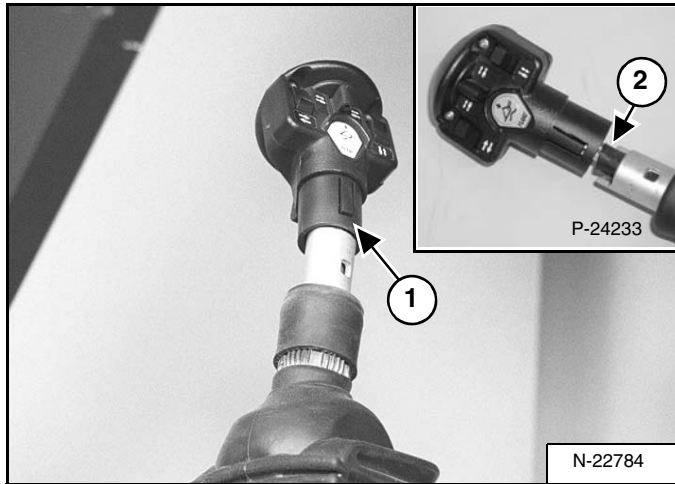

Pull the switch handle and wiring harness assembly (Item 1) [Figure 60-130-12] from the control lever.

Cut the wires (Item 2) [Figure 60-130-12] below the switch handle and remove switch handle.

NOTE: Only cut the wires if the switch handle is bad and needs replacement. If the switch handle is good and just needs to be removed for control handle or lever replacement, then remove the connectors on the end of the harness and pull switch handle and harness up through the top of the lever tube.

Figure 60-130-13

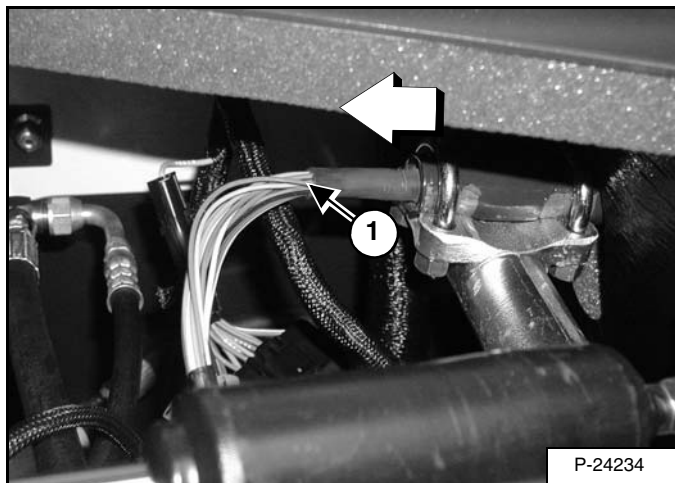

If the harness has been cut: pull the harness (Item 1) [Figure 60-130-13] out through the bottom of the control lever tube.

Switch Handle Installation

Figure 60-130-14

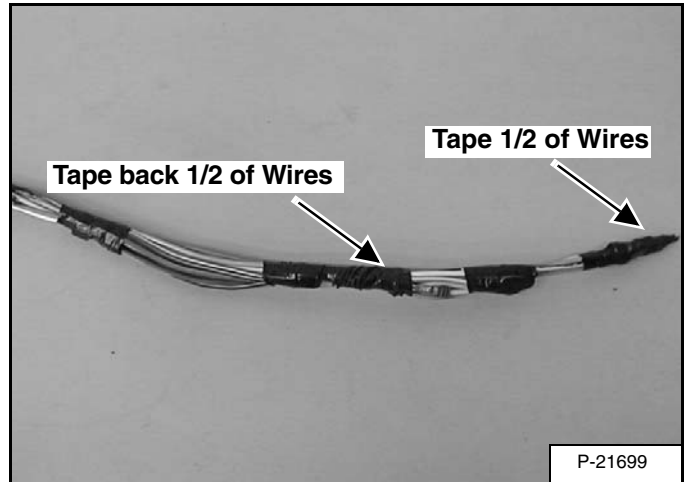

When installing the new switch handle, tape the wire terminals together.

The switch handle comes with a 6 in. piece of heat shrink tubing placed over the end of the wires. Remove the heat shrink tube from the end of the wires before routing the harness through handle and control lever tube.

NOTE: Leave all the other heat shrink tube on the wires for protection.

Tape half of the wires back and half forward [Figure 60-130-14] to keep the harness small enough to route through the control lever tube.

ELECTRICAL/HYDRAULIC CONTROLS (SJC) (CONT'D)

Identification Chart (Cont'd)

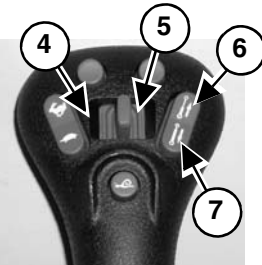
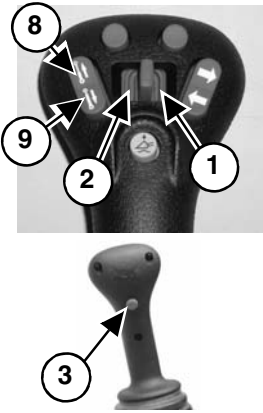
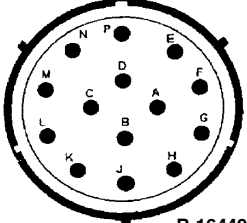
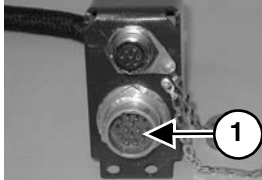
Left Side Control Handle Switches	Switch Number	Solenoid Number Activated				Attachment Harness Terminal Activated	Right Side Control Handle Switches
		STD	RH	HFH	HRH		
		STD	RH	HFH	HRH		
	1	1	1	1, 6	1, 6	K	
	2	2	2	2	2	K	
	3	1	1	1, 6	1, 6	K	
	4	2	3, 5	2	3, 5	K, A, D	
	5	1	3, 4	1	3, 4	K, A, C	
	6	1	3, 4	1	3, 4	K, E	
	7	1	3, 4	1	3, 4	K, F	
	8	1	3, 4	1	3, 4	K, G	
9	1	3, 4	1	3, 4	K, H		
Attachment Harness Connector							
<p>Fourteen Pin Connector Viewed from front (pin side of connector) of loader.</p>   <p style="text-align: center;">B-16449</p>							

NOTE: All diagnostics must be done at the fourteen pin connector (Item 1). (If so equipped as a dealer installed kit.)

The ACD (Attachment Control Device) automatically recognizes the use of the seven or fourteen pin connector when connected.

If the ACD light flashes, check for diagnostic service codes. See the Electrical System Service Manual for the proper procedure.

RH - Loaders with Rear Hydraulics Option.

HFH - Loaders with High Flow Hydraulics Option.

* If harness terminals K & L are jumped together, switches 4 thru 9 will function the same as switch 1 & 2.

* Terminal K is activated with Key switch ON.

HRH - Loaders with High Flow and Rear Hydraulics Option.

CALIBRATION (CONT'D)

Lift And Tilt Calibration (SJC) (Cont'd)

Figure 60-160-10

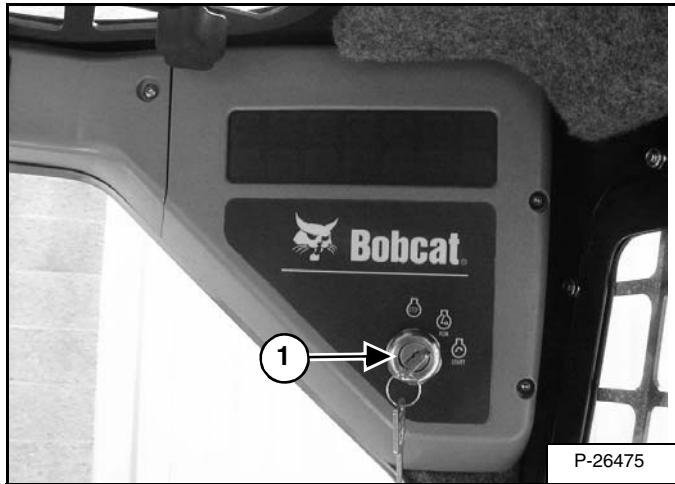

Figure 60-160-11



Turn the key (Item 1) [Figure 60-160-10] to the RUN position or press the RUN/ENTER button (Item 1) [Figure 60-160-11] for power, without starting the loader.

The loader Control Pattern Switch (Item 1) [Figure 60-160-8] will start flashing and will continue to flash until the calibration procedure is completed.

Figure 60-160-12

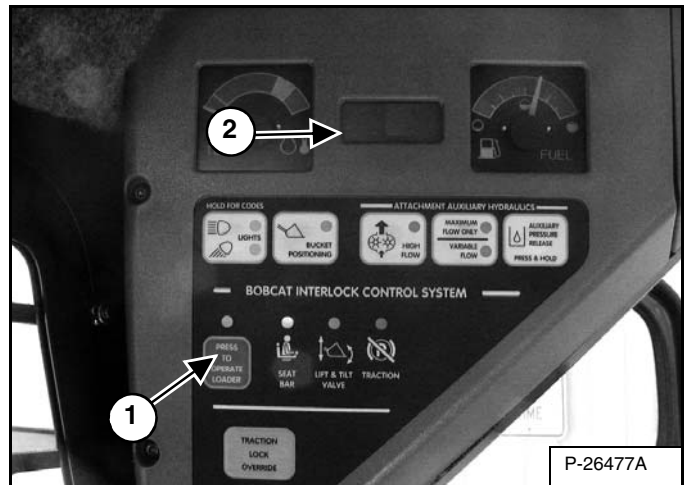

At the left panel, press the PRESS TO OPERATE Button (Item 1) [Figure 60-160-12] while holding the right joystick in position.

Release the joystick.

NOTE: During the calibration cycle, the system will beep three times. Once the calibration is complete code 32-24 (Calibration Performed) will be generated.

The ACS controller will cycle the actuators.

The lift and tilt calibration is complete.



Bobcat®

MAINTENANCE CLOCK (CONT'D)

Setup (Cont'd)

Figure 60-200-11



A green **COMPLETE** (Item 1) [Figure 60-200-11] message will be displayed when the dealer information has been transferred to the machine controller.

Click **Back** (Item 2) [Figure 60-200-11] to return to the Bobcat Service Analyzer screen.

Figure 60-200-12

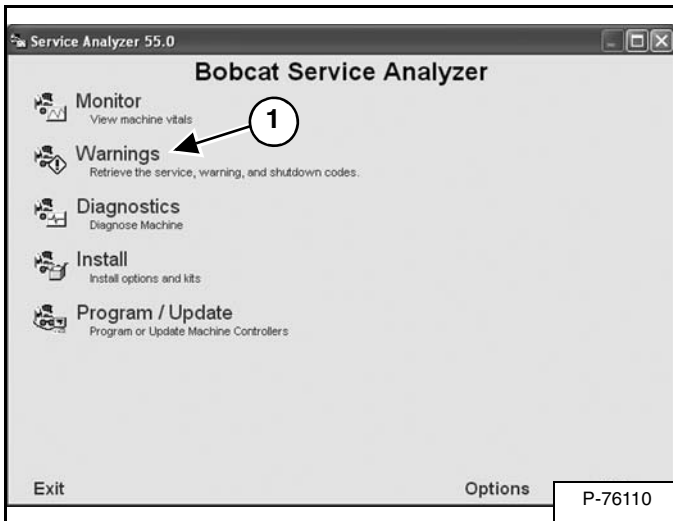

Select **Warnings** (Item 1) [Figure 60-200-12].

Figure 60-200-13

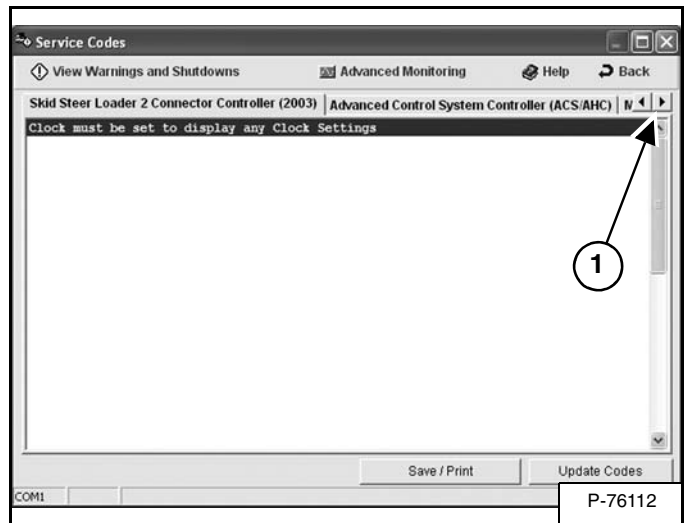

Click the right arrow (Item 1) [Figure 60-200-13] to scroll through the tabs.

NOTE: The Maintenance tab (Item 1) [Figure 60-200-14] will not appear when servicing loaders equipped with the older controller.

Figure 60-200-14

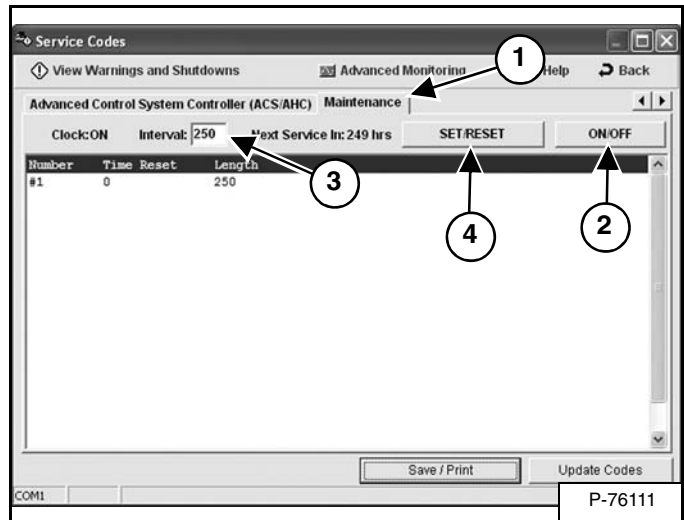

Click the **Maintenance** tab (Item 1) [Figure 60-200-14] to view the maintenance clock screen.

Click **ON/OFF** (Item 2) to turn the maintenance clock on or off [Figure 60-200-14].

The default Interval (Item 3) is 250 hours, it can also be changed by placing the cursor in the box and typing the new interval. Click **SET/RESET** (Item 4) [Figure 60-200-14] to reset and set the maintenance clock.

ENGINE SERVICE (CONT'D)

ENGINE INFORMATION	70-10-1
Compression - Checking	70-10-19
Description	70-10-1
Engine Mount Replacement	70-10-18
Engine Removal And Installation	70-10-11
Engine Torque Values	70-10-9
Specifications (Kubota V2203-M-DI)	70-10-2
Specifications (Kubota V2003-M-DI-T (Turbo))	70-10-6
Troubleshooting	70-10-9
ENGINE SPEED CONTROL	70-20-1
Removal And Installation	70-20-1
ENGINE SPEED CONTROL (SJC)	70-21-1
Disassembly And Assembly	70-21-3
Removal And Installation	70-21-1
FLYWHEEL AND HOUSING	70-120-1
Flywheel Removal And Installation	70-120-1
Housing Removal And Installation	70-120-2
Ring Gear Removal And Installation	70-120-1
FUEL SYSTEM	70-70-1
Fuel Camshaft Governor Disassembly And Assembly	70-70-2
Fuel Camshaft Removal And Installation	70-70-1
Fuel Injection Pump Removal And Installation (Turbo)	70-70-4
Fuel Injection Pump Removal And Installation (Non-Turbo)	70-70-7
Fuel Injector Nozzle Pressure - Checking	70-70-15
Fuel Injector Removal And Installation	70-70-13
Fuel ShutOff Solenoid - Checking	70-70-3
Fuel ShutOff Solenoid Removal And Installation	70-70-3
Injection Pump - Timing	70-70-11
Nozzle Spray Condition	70-70-15
Valve Seat Tightness	70-70-16
LUBRICATION SYSTEM	70-60-1
Engine Oil Pressure-Testing	70-60-3
Oil Pan Removal And Installation	70-60-1
Oil Pump Inspection	70-60-2
Oil Pump Removal And Installation	70-60-1

Continued On Next Page

ENGINE INFORMATION (CONT'D)

Specifications (Kubota V2003-M-DI-T (Turbo)) (Cont'd)

All dimensions are given in inches. Respective metric dimensions are given in millimeters enclosed by parentheses.

Crankshaft

Crankshaft Alignment Limit Permitted	0.00079 (0,02)
Oil Clearance Between Journal & Bearing #1	0.0016 - 0.0046 (0,04 - 0,118)
Limit Permitted	0.0079 (0,2)
Journal O.D. #1	2.3591 - 2.3598 (59,921 - 59,940)
Bearing I.D. #1	2.3614 - 2.3637 (59,98 - 60,039)
Oil Clearance Between Journal & Bearing #2	0.0016 - 0.0041 (0,04 - 0,104)
Limit Permitted	0.0079 (0,2)
Journal O.D. #2	2.3591 - 2.3598 (59,921 - 59,940)
Bearing I.D. #2	2.3614 - 2.3632 (59,98 - 60,025)
Oil Clearance Between Crank Pin & Bearing	0.0010 - 0.0034 (0,025 - 0,087)
Limit Permitted	0.0079 (0,2)
Crank Pin O.D.	1.8488 - 1.8494 (46,96 - 46,97)
Crank Pin Bearing I.D.	1.8504 - 1.8522 (47,0 - 47,046)
Crankshaft Side Clearance	0.0059 - 0.0138 (0,15 - 0,35)
Limit Permitted	0.0197 (0,5)

Timing Gear

Timing Gear Backlash:	
Crank Gear-Idle Gear	0.0016 - 0.0044 (0,0415 - 0,1122)
Allowable Limit	0.0059 (0,15)
Idle Gear-Cam Gear	0.0016 - 0.0045 (0,0415 - 0,1154)
Allowable Limit	0.0059 (0,15)
Idle Gear-Injection Pump Gear	0.0016 - 0.0045 (0,0415 - 0,1154)
Allowable Limit	0.0059 (0,15)
Crank Gear-Oil Pump Gear	0.0016 - 0.0043 (0,0415 - 0,109)
Allowable Limit	0.0059 (0,15)
Clearance Between Idle Gear Shaft & Idle Gear Bushing:	
Idle Gear	0.001 - 0.0026 (0,025 - 0,066)
Allowable Limit	0.0039 (0,10)
Idle Gear Bushing I.D.	1.4961 - 1.4970 (38,0 - 38,025)
Allowable Limit	0.0039 (0,10)
Idle Gear Shaft O.D.	1.4944 - 1.4951 (37,959 - 37,975)
Idle Gear Side Clearance Idle Gear	0.0079 - 0.020 (0,2 - 0,51)
Allowable Limit	0.0315 (0,8)

Thermostat

Valve Opening Temperature	176.9° - 182.3° F (80.5° - 83.5° C)
Valve Fully Open	203° F (95° C)

ENGINE INFORMATION (CONT'D)

Engine Mount Replacement

Figure 70-10-27

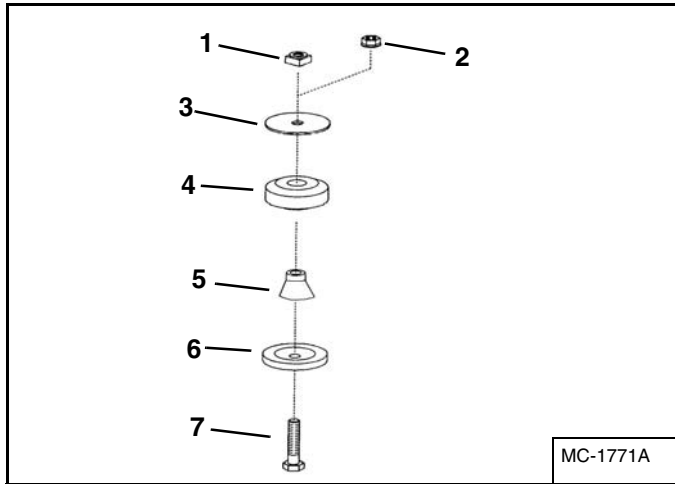

Use the following procedure to install new engine mounts:

Remove the existing mount from the engine. Refer to engine removal and installation for engine mount locations.

Replace all four engine mounts two front and two rear.

Use the parts shown to install the new engine mounts [Figure 70-10-27]:

Square Nut - (Item 1) - Used on left side engine mounts

Hex Nut - (Item 2) - Used on right side engine mounts

Mount Washer - (Item 3)

Engine Mount - (Item 4)

Tube Spacer - (Item 5)

Snubbing Washer - (Item 6)

Mounting Bolt - (Item 7)

Figure 70-10-28

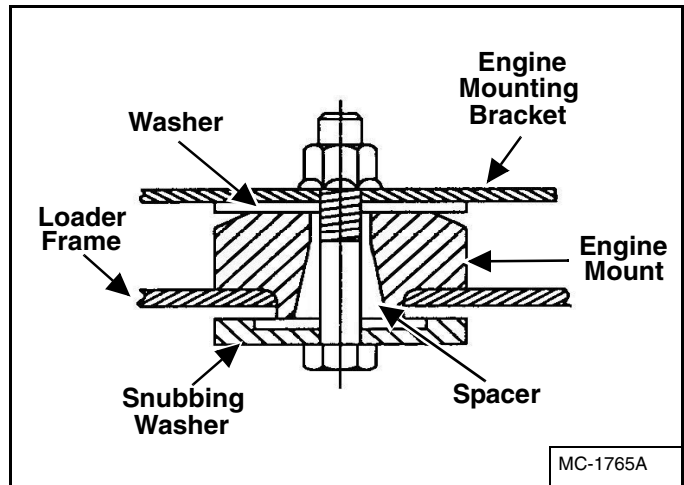

Install the new engine mount as shown in the cut away side view [Figure 70-10-28].

Tighten the mounting bolts to 70 ft.-lb. (95 N•m) torque.

ENGINE SPEED CONTROL (SJC) (CONT'D)

Disassembly And Assembly (Cont'd)

Figure 70-21-12

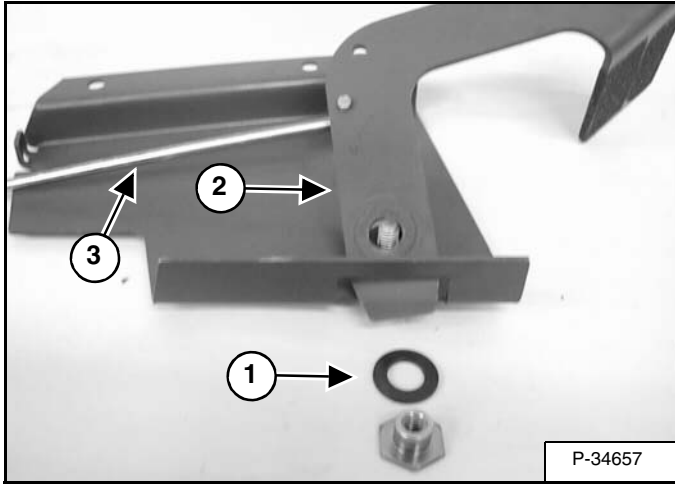

Remove the fiber washer (Item 1) [Figure 70-21-12] from the bushing/nut.

Remove the foot pedal lever (Item 2) and linkage rod (Item 3) [Figure 70-21-12].

Figure 70-21-13

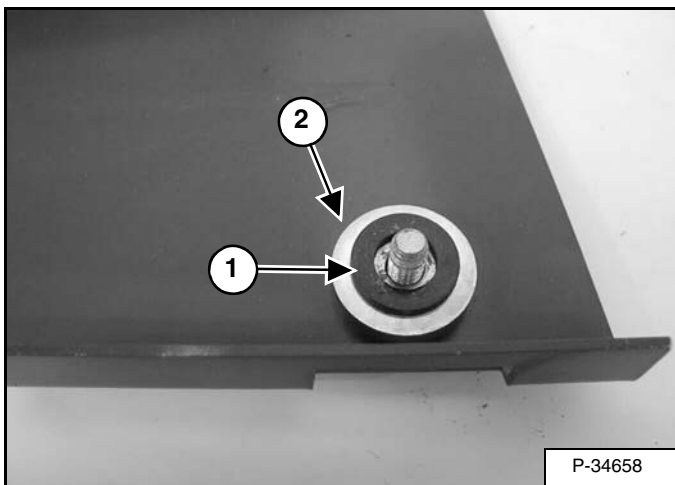

Remove the fiber washer (Item 1) and washer (Item 2) [Figure 70-21-13] from the pivot bolt.

Figure 70-21-14

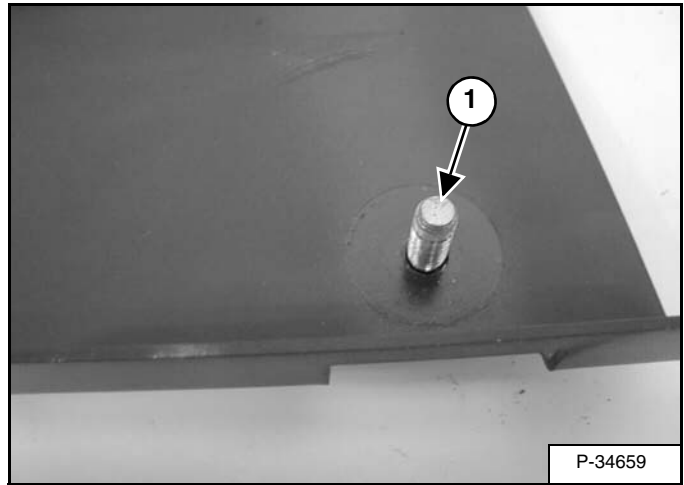

Remove the pivot bolt (Item 1) [Figure 70-21-14] from the speed control.

Figure 70-21-15

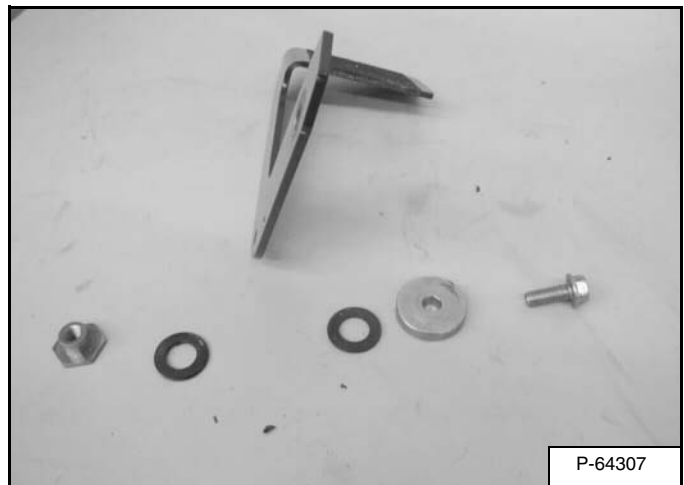

The pivot assembly shown disassembled [Figure 70-21-15].

NOTE: No lubrication is necessary or recommended on the engine speed control.

Reverse the disassembly procedure to assemble the (SJC) speed control.

ENGINE COOLING SYSTEM (CONT'D)

Hydraulic Fan Removal And Installation

Figure 70-50-13

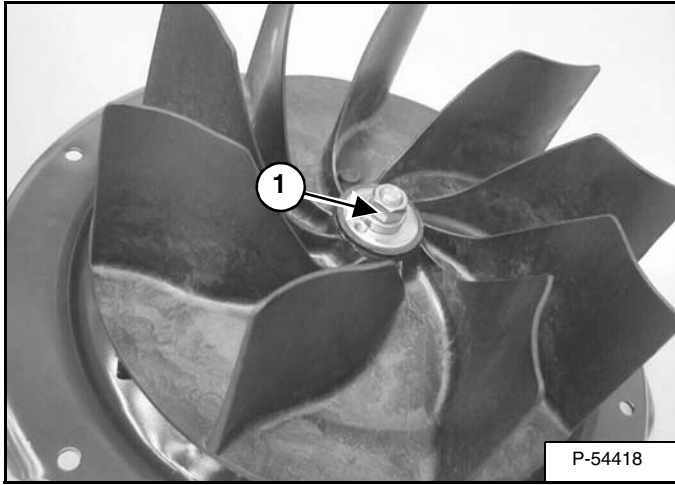

Remove the lock nut and spacer (Item 1) [Figure 70-50-13].

Installation: Tighten the nut to 45 - 55 ft.-lb. (61 - 75 N•m) torque.

Figure 70-50-14

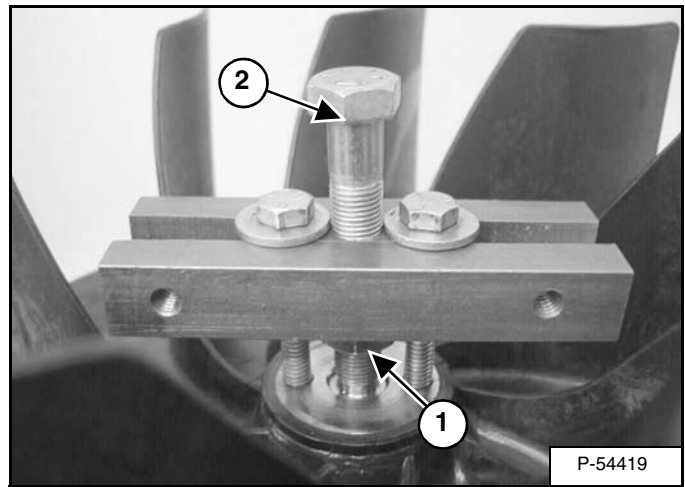

Use the following procedure to remove the fan from the shaft:

Install the nut (Item 1) [Figure 70-50-14] on the tapered shaft to protect the shaft and threads.

Install the puller on the fan as shown [Figure 70-50-14].

As the center bolt (Item 2) [Figure 70-50-14] is tightened, periodically strike the bolt head to loosen the fan from the shaft.

Remove the fan from the tapered shaft [Figure 70-50-14].

Figure 70-50-15

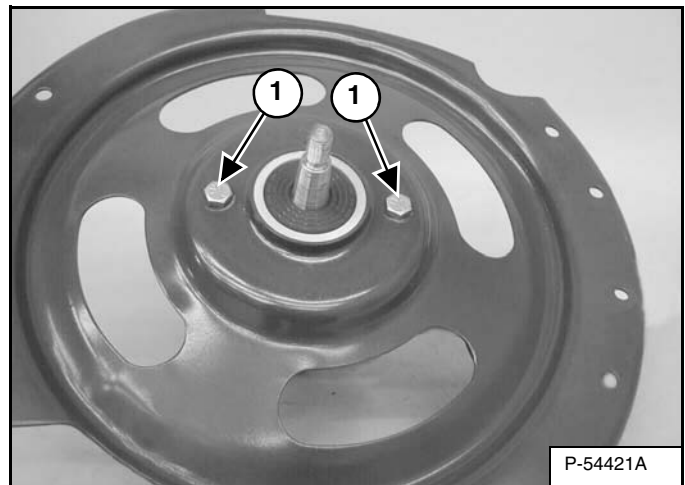

To remove the blower housing mounting plate, remove the two bolts (Item 1) [Figure 70-50-15].

FUEL SYSTEM (CONT'D)

Fuel Camshaft Governor Disassembly And Assembly

Figure 70-70-3

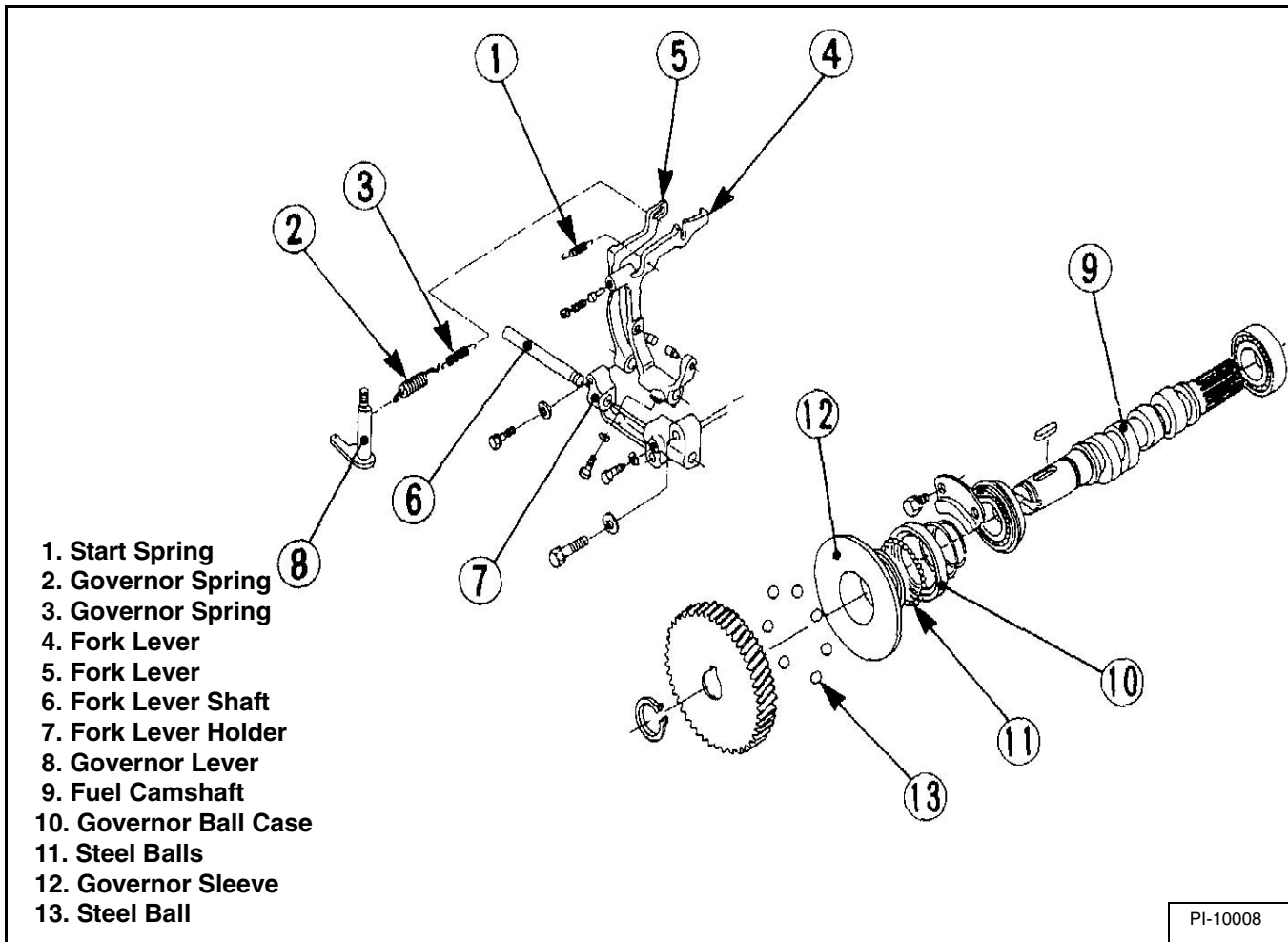

The governor serves to keep the engine speed constant by automatically adjusting the amount of fuel supplied to the engine according to changes in the engine load.

Disassemble and assemble the governor and fuel camshaft as shown in figure [Figure 70-70-3].

Check all the parts for wear or damage and replace as needed.

FUEL SYSTEM (CONT'D)

Injection Pump - Timing (Cont'd)

Figure 70-70-33

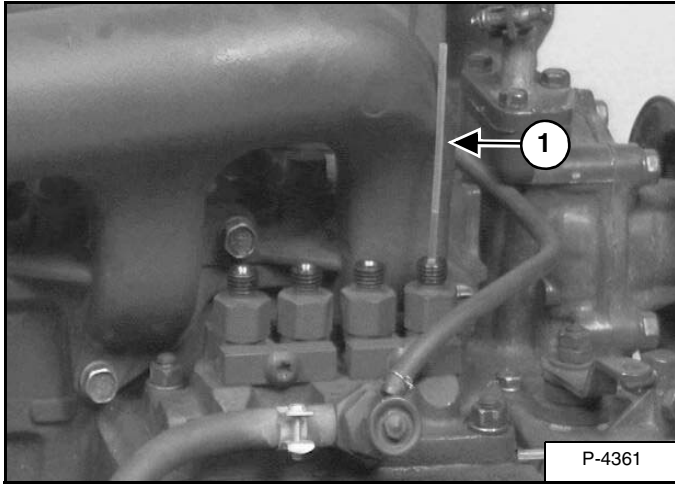

Install a short plastic tube (Item 1) [Figure 70-70-33] in the number one cylinder port of the injection pump. The tube should fit securely in the port and point upward.

Figure 70-70-34

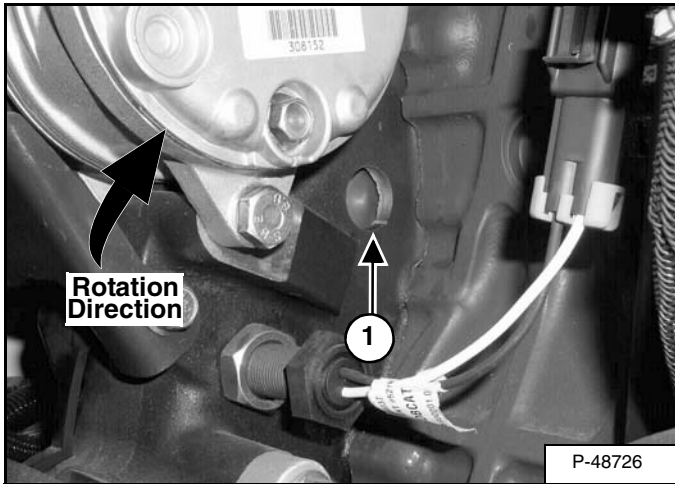

Rotate the engine in the direction shown [Figure 70-70-34].

Continue rotation until flywheel timing mark just appears in the window (Item 1) [Figure 70-70-34].

NOTE: The flywheel has three timing marks.

The first mark to appear in the window with the rotation is 9.25° which is used for loaders with the Kubota V2003T engine.

The second mark to appear in the window is 8.2° which is used for loaders with the Kubota V2203 engine.

The third mark to appear in the window is 6.75° which is used for loaders with the Kubota V2403 engine.

Rotate slowly until fuel just starts to flow upward into the plastic tube.

At this instant, the 9.25° BTDC timing mark on the flywheel should be aligned with the mark in the window (Item 1) [Figure 70-70-34] for the V2003T engine.

OR

The 8.2° BTDC on the flywheel should be aligned with the mark in the window (Item 1) [Figure 70-70-34] for the V2203 engine.

Figure 70-70-35

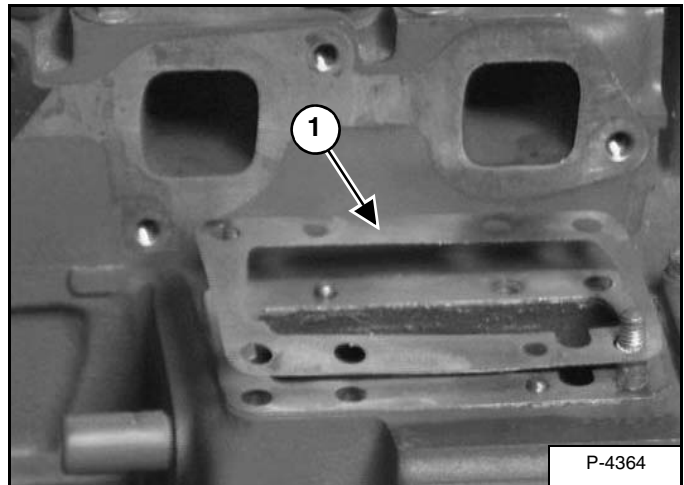

Add or subtract shim(s) (Item 1) [Figure 70-70-35] as needed to adjust the fuel delivery timing.

NOTE: Adding or removing one shim will vary the timing by 1.5° . Adding shims retards timing.

CYLINDER HEAD (CONT'D)

Cylinder Head Removal And Installation (Cont'd)

Figure 70-80-18

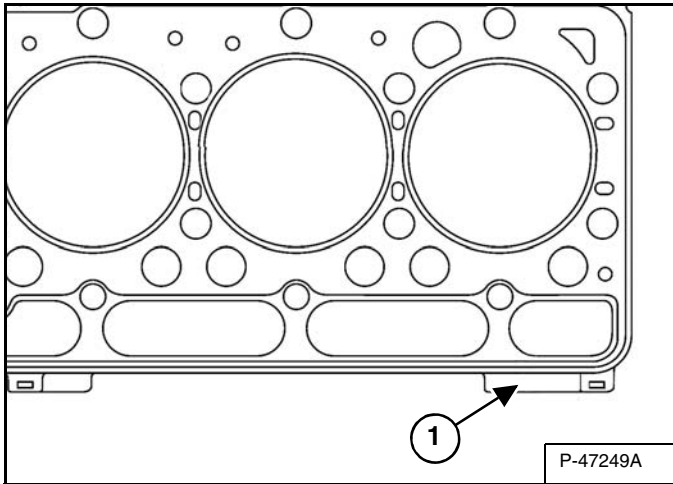

When replacing just the gasket, use a new gasket that has the same mark (Item 1) [Figure 70-80-18] as the original gasket.

When replacing the gasket after an engine rebuild, the piston protrusion must be measured.

(See Cylinder Head Top Clearance on Page 70-80-8.)

Figure 70-80-19

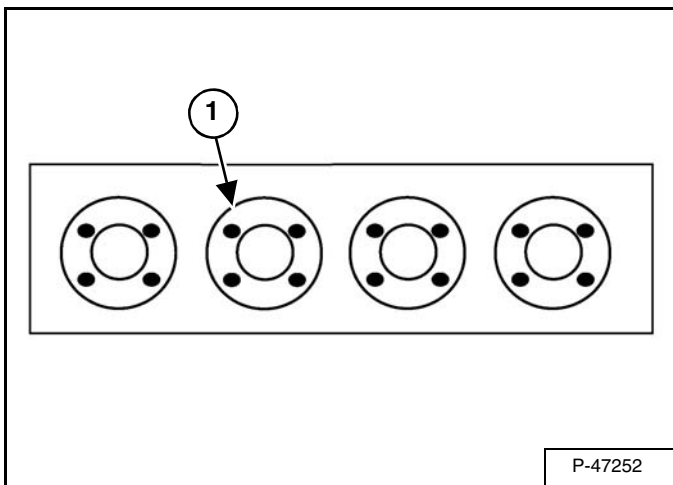

Measure and record the protrusion of each piston in the four places shown (Item 1) [Figure 70-80-19]. Find the average of each piston, then find the combined average of the four pistons.

Figure 70-80-20

Gasket Size (Number)	Piston Protrusion
15	0.475 to 0.525 mm 0.0187 to 0.0207 in.
20	0.525 to 0.575 mm 0.0207 to 0.0226 in.
25	0.575 to 0.625 mm 0.0226 to 0.0246 in.
30	0.625 to 0.667 mm 0.0246 to 0.0266 in.
35	0.675 to 0.725 mm 0.0266 to 0.0285 in.

Select the correct gasket size (thickness) from the chart [Figure 70-80-20].

Find the measurement of the highest piston protrusion and the lowest piston protrusion (recorded earlier) for each piston.

If the highest measurement exceeds the piston protrusion of the selected gasket, use the gasket which is one size larger. If the measurement exceeds gasket size 35, the engine must be disassembled, clearances checked, and reassembled.

If the measurement is two sizes smaller than the selected gasket or smaller than gasket size 15, the engine must be disassembled, clearances checked, and reassembled.

After the gasket and cylinder head have been installed, turn the crankshaft by hand to be sure there is no interference between the piston, cylinder, and valves.

CRANKSHAFT AND PISTONS (CONT'D)

Piston And Connecting Rod - Servicing (Cont'd)

Figure 70-90-11

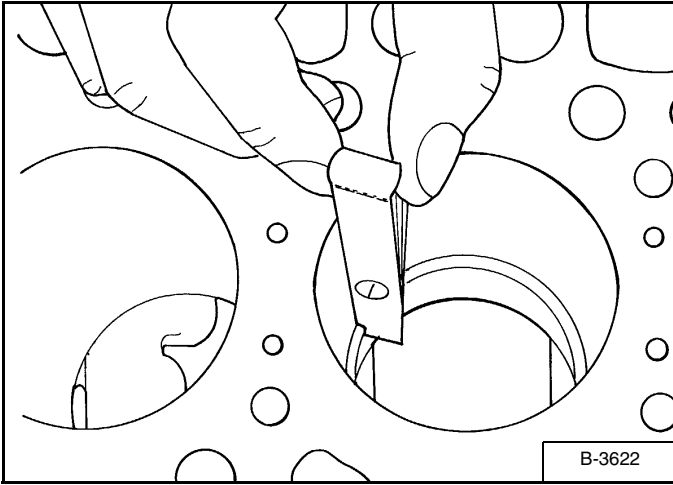

Install a piston ring into the lower part of the cylinder bore. Measure the ring gap with a feeler gauge [Figure 70-90-11].

If the gap exceeds the allowable limit, replace the ring.

Kubota V2203-M-DI

Top Ring Gap	0.0079 - 0.0138 in. (0,2 - 0,35 mm)
Oil Ring Gap	0.0079 - 0.0157 in. (0,20 - 0,40 mm)
Allowable Limit	0.0492 in. (1,25 mm)
Second Ring Gap	0.0138 - 0.0197 in. (0.35 - 0,50 mm)

Kubota V2003-M-DI-T (Turbo)

Top Ring Gap	0.0079 - 0.0138 in. (0,2 - 0,35 mm)
Oil Ring Gap	0.0098 - 0.0177 in. (0,25 - 0,45 mm)
Allowable Limit	0.0492 in. (1,25 mm)
Second Ring Gap	0.0157 - 0.0217 in. (0.40 - 0,55 mm)

Figure 70-90-12

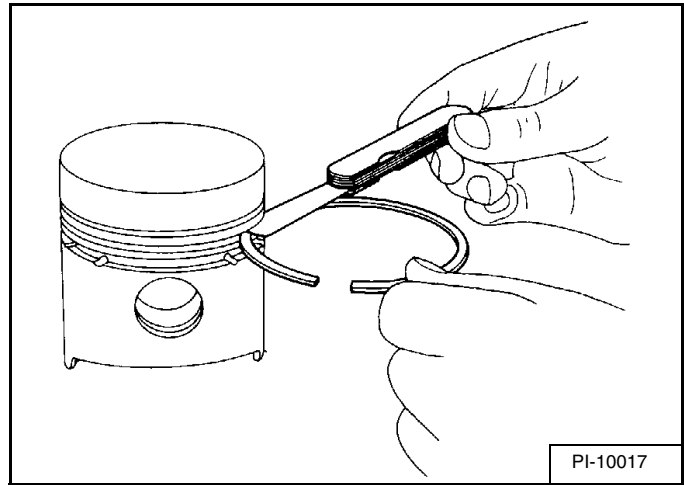

Remove the carbon from the ring grooves. Measure the clearance between the ring and groove with a feeler gauge [Figure 70-90-12].

If the clearance exceeds the allowable limit, replace the ring. If the clearance still exceeds the allowable limit, replace the piston.

Kubota V2203-M-DI

Compression Rings	0.0020 - 0.0035 in. (0,05 - 0,09 mm)
Allowable Limit	0.0079 in. (0,2 mm)
Oil Ring	0.0012 - 0.0028 in. (0,03 - 0,07 mm)
Allowable Limit	0.0059 in. (0,15 mm)

Kubota V2003-M-DI-T (Turbo)

Compression Rings	0.0037 - 0.0050 in. (0,093 - 0,128 mm)
Allowable Limit	0.0079 in. (0,2 mm)
Oil Ring	0.0008 - 0.0024 in. (0,02 - 0,06 mm)
Allowable Limit	0.0059 in. (0,15 mm)

CAMSHAFT AND TIMING GEARS (CONT'D)

Timing Gearcase Cover Removal And Installation (Cont'd)

Figure 70-100-5

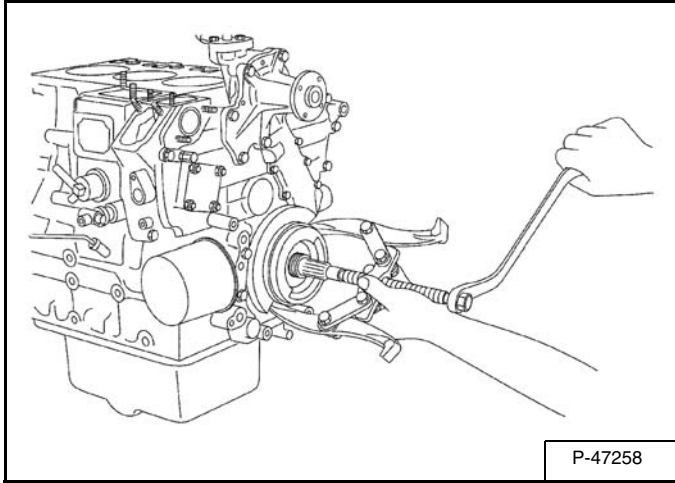

Use a puller and remove the crankshaft pulley. [Figure 70-100-5].

Figure 70-100-6

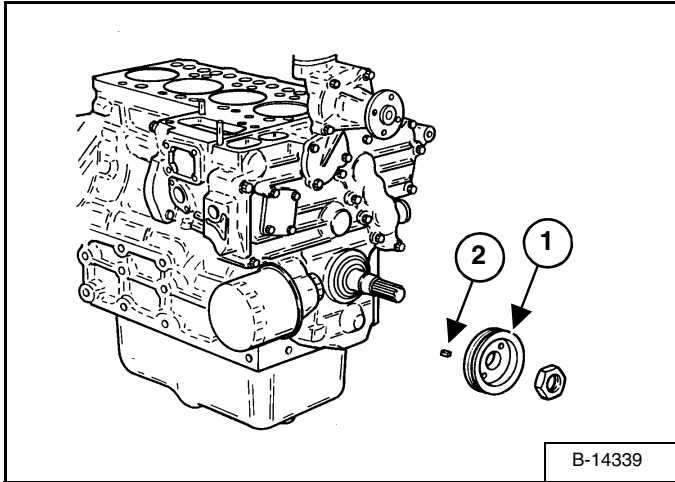

Remove the crankshaft pulley (Item 1) and key (Item 2) [Figure 70-100-6].

Remove the bolts from the timing gearcase cover.

Installation: Tighten the bolts to 13 - 15 ft.-lb. (18 - 20 nm) torque.

Figure 70-100-7

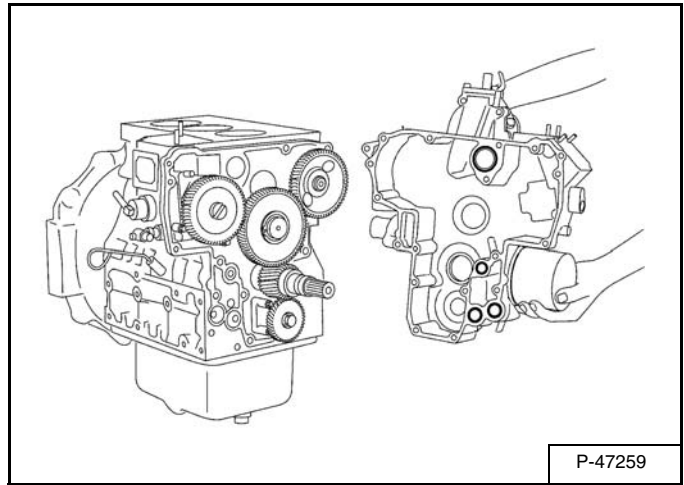

Remove the timing gearcase cover [Figure 70-100-7].

Figure 70-100-8

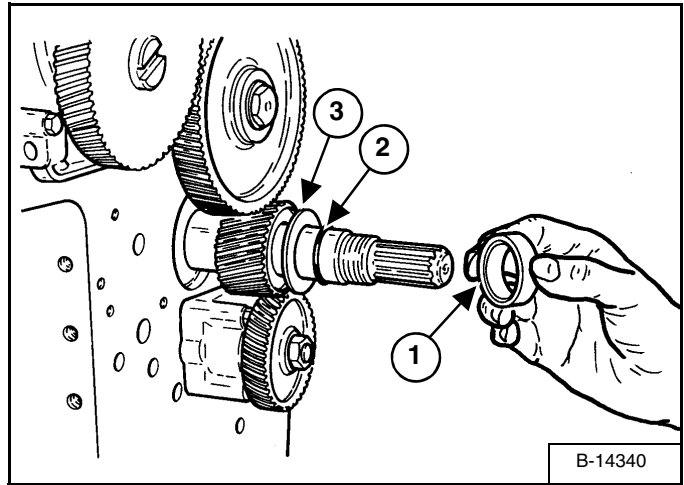

Remove the crankshaft collar (Item 1), O-ring (Item 2) and oil slinger (Item 3) [Figure 70-100-8].

FLYWHEEL AND HOUSING (CONT'D)

Housing Removal And Installation

Remove the drive belt shield. (See Shield Removal And Installation on Page 30-60-1.)

Remove the engine/hydrostatic pump package from the loader. (See Engine Removal And Installation on Page 70-10-11.)

Remove the drive belt. (See Belt Removal And Installation on Page 30-60-3.)

Remove the drive belt tension pulley. (See Belt Tensioner Removal And Installation on Page 30-60-4.)

Remove the starter. (See Removal And Installation on Page 60-40-2.)

Remove the flywheel. (See Flywheel Removal And Installation on Page 70-120-1.)

Figure 70-120-3

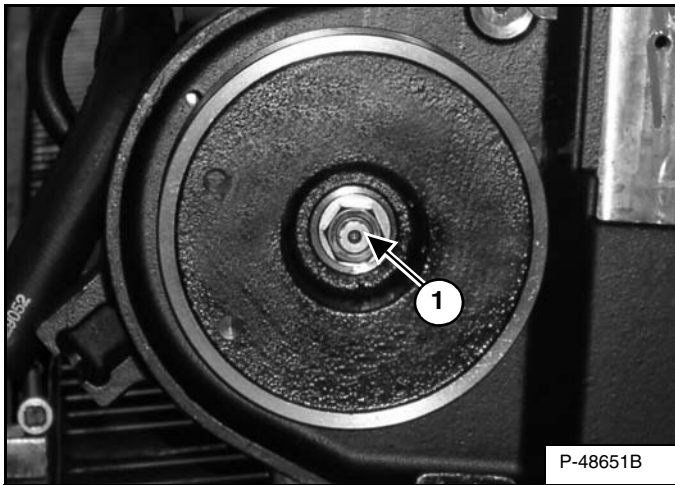

Remove the hydrostatic pump drive pulley mounting nut (Item 1) [Figure 70-120-3] and washer.

Installation: Tighten the mounting nut to 175 - 200 ft.-lb. (237 - 271 N•m) torque.

Figure 70-120-4

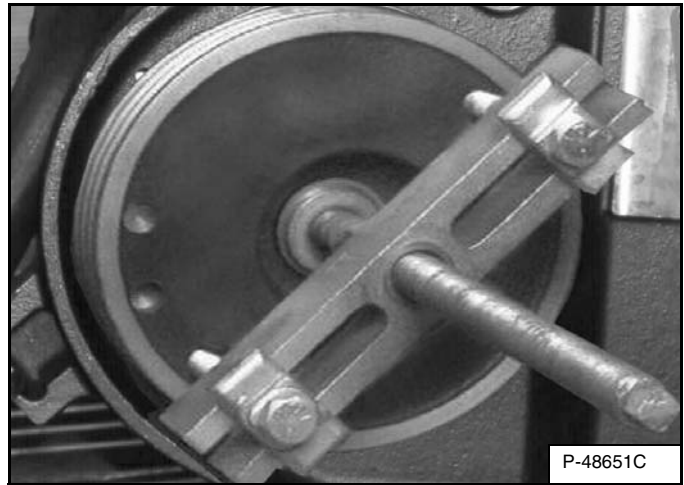

Install a puller in the drive pulley and remove the pulley from the hydrostatic pump shaft [Figure 70-120-4].

Installation: Install the pulley key in the shaft before installing the drive pulley.

AIR CONDITIONING SYSTEM FLOW (CONT'D)

Components (Cont'd)

Figure 80-10-16

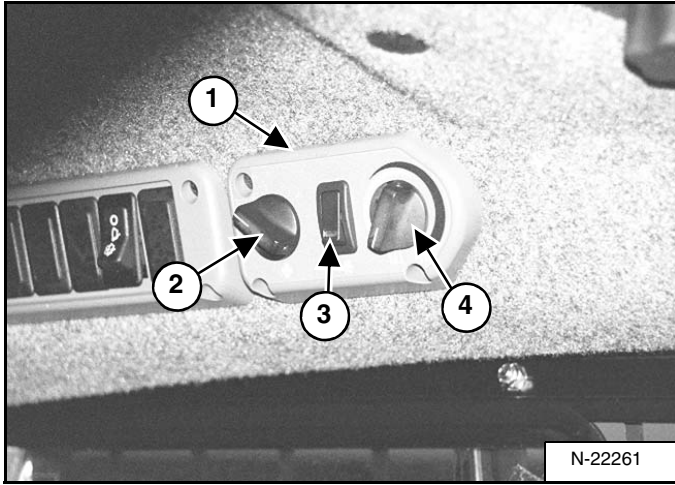

Control Panel: The panel (Item 1) [Figure 80-10-16] has three separate components.

Fan Switch: This is a four position rotary switch (Item 2) [Figure 80-10-16]. When the fan switch is in the off position the A/C will not engage, but the heat valve will operate, as it is controlled by the ignition power.

A/C Switch: The rocker switch (Item 3) [Figure 80-10-16] will be illuminated when the A/C is engaged.

Potentiometer: The potentiometer (Item 4) [Figure 80-10-16] controls the Heat Valve from fully Off to fully On. This can be used in conjunction with the A/C for defrost of the windows and temperature control.

Figure 80-10-17

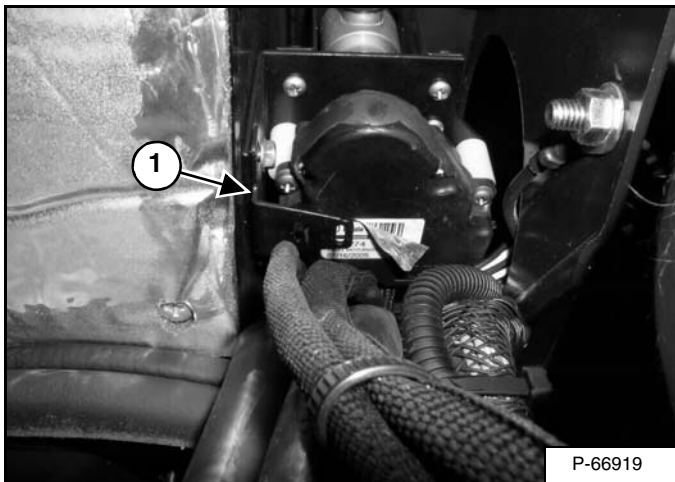

Heater Valve: The heater valve (Item 1) [Figure 80-10-17] is used to control the amount of engine coolant that flows to the heater coil.

Figure 80-10-18

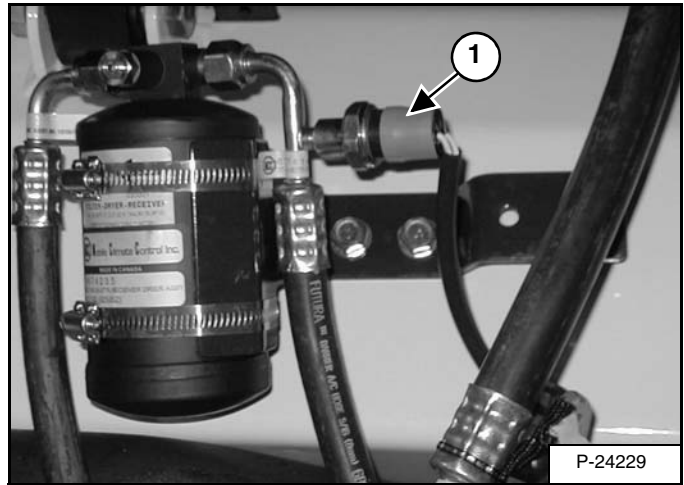

Pressure Switch: The pressure switch (Item 1) [Figure 80-10-18] will disengage the compressor clutch at high pressure readings over 384 PSI. (2647 bar) on the high side, or at very low pressure of 28 PSI (193 bar) or less on the high side, which indicates loss of refrigerant.

TROUBLESHOOTING (CONT'D)

Gauge Pressure Related Troubleshooting

Normal compressor suction (low side) and discharge (high side) pressure at ambient temperatures of 86-96 degrees F (30-38 degrees C) and compressor speed of approximately 2000 RPM are:

High pressure side pressure: 210-265 PSI

Low pressure side pressure: 15-33 PSI

As a rule of thumb, the high side pressure will be around eight times greater than the low side pressure.

Possible Cause	Inspection	Solution
Low pressure side too high.	The low pressure side pressure normally becomes too high when the high pressure side pressure is too high. As this is explained below, the following inspection is only used when the low pressure side is too high.	
1. Expansion valve opens too far.	Frost is present on the suction hose.	Replace expansion valve.
2. Defective compressor.	The high and low pressure side gauge pressures equalize when the compressor is engaged.	Replace compressor.
Low pressure side Too low.		
1. Low refrigerant charge.	The high side pressure will be low and bubbles may be present in sight glass on receiver drier.	Repair any leaks and recharge the refrigerant to the correct level.
2. Clogged or closed expansion valve.	The expansion valve's inlet side is frosted. Moisture or other Contaminants can be the cause.	Clean or replace the expansion Valve.
3. Restriction between drier and expansion valve.	Frost on the line between drier and expansion valve. A Negative low pressure reading may be shown.	Flush system or replace hose.
High pressure side Too high.		
1. Poor condenser performance.	Dirty or clogged condenser fins. Condenser fans not Operating.	Clean fins, and/or repair the fan.
2. Excessive refrigerant.	The high pressure side pressure will be high.	Use refrigerant recovery equipment to capture excess refrigerant. Charge to the correct refrigerant level.
3. Excessive oil charge.	The high pressure side will be high.	Evacuate system. Remove oil from condenser and compressor. Measure oil from compressor and add correct oil charge back into compressor. Flush system with nitrogen. Replace drier.
4. Air in system.	Pressure is high on both high and low sides.	Evacuate and recharge with Refrigerant.
5. Restriction in drier, condenser or high pressure line.	High pressure side will be high, and low pressure side will be low.	Evacuate and flush system replacing defective parts.
High pressure side Too low.		
1. Low refrigerant charge.	The high side pressure will be low and bubbles may be present in sight glass on receiver drier.	Repair any leaks and recharge the refrigerant to the correct level.

TROUBLESHOOTING (CONT'D)

Electrical System (Cont'd)

Figure 80-30-8

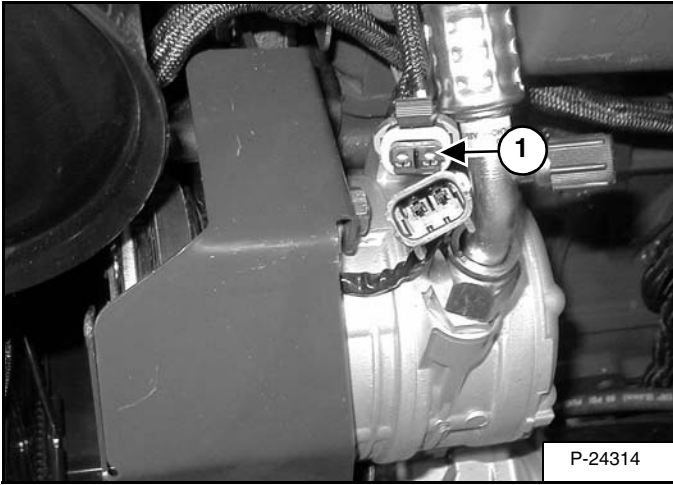

With a multi meter, check the voltage to the compressor clutch at the loader harness (Item 1) [Figure 80-30-8]

The voltage reading should be around 12 volts.

If there is no power at the clutch, check the wiring harness for broken wires.

If there is power at the clutch, reconnect the wiring harness to the compressor clutch.

Figure 80-30-9

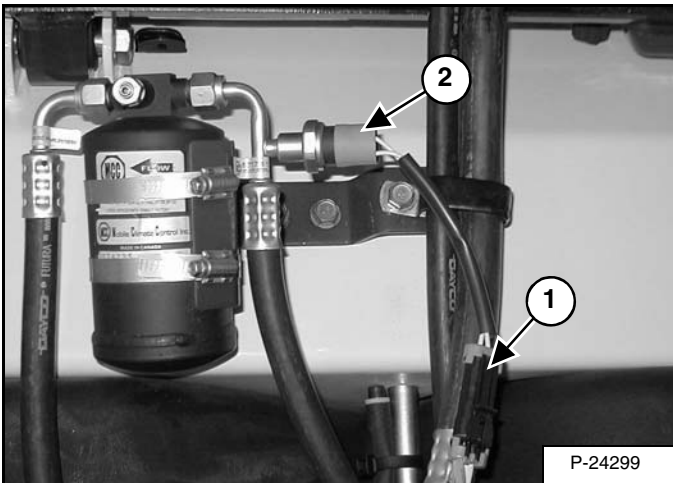

Disconnect the loader harness (Item 1) from the pressure switch (Item 2) [Figure 80-30-9].

Figure 80-30-10

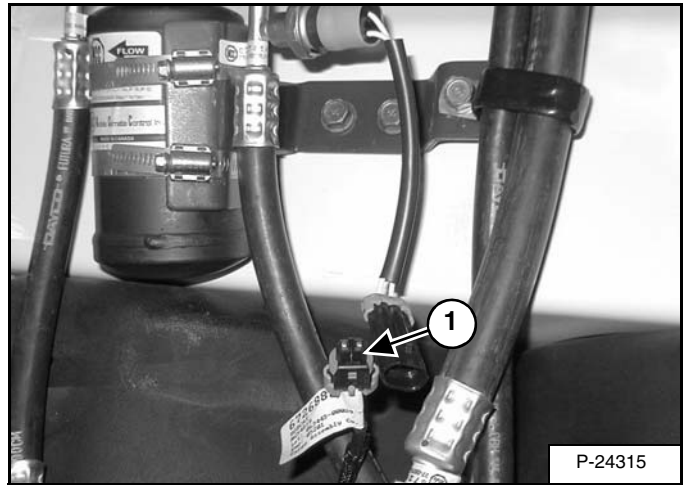

Using a multi meter check the loader wiring harness (Item 1) [Figure 80-30-10] for voltage.

The voltage should be around 12 volts.

If there is no voltage at the wiring harness, check the harness for broken wires.

Figure 80-30-11

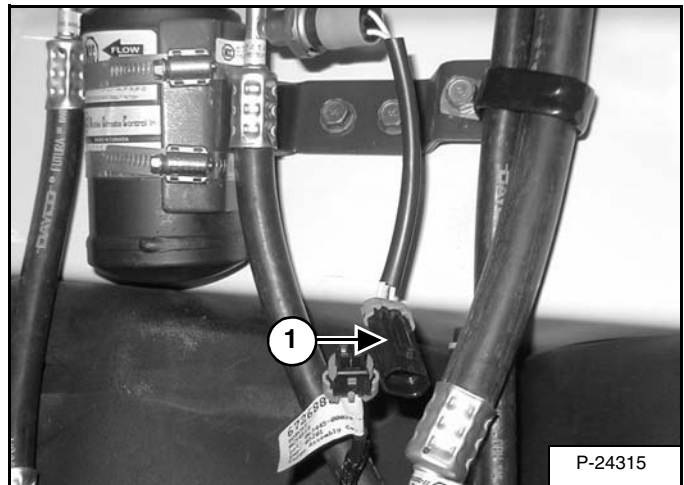

If there is voltage at the harness, check the resistance at the pressure switch (Item 1) [Figure 80-30-11].

If there is no resistance value, check for low refrigerant level. (See Refrigerant Identification on Page 80-40-1.)

If a resistance value is observed, the pressure switch is good.

Reconnect the loader harness to the pressure switch.

SYSTEM CHARGING AND RECLAMATION (CONT'D)

Reclamation And Charging With Recovery / Charging Unit

Figure 80-40-3

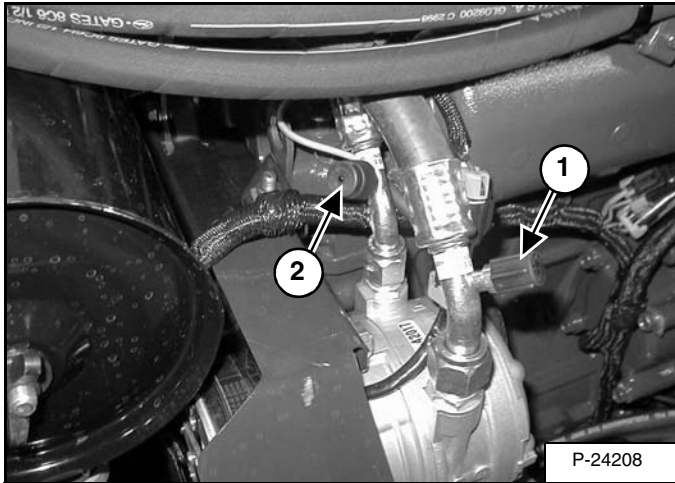

Open the rear door and locate the low pressure port (Item 1), and high pressure port (Item 2) [Figure 80-40-3].

Figure 80-40-4

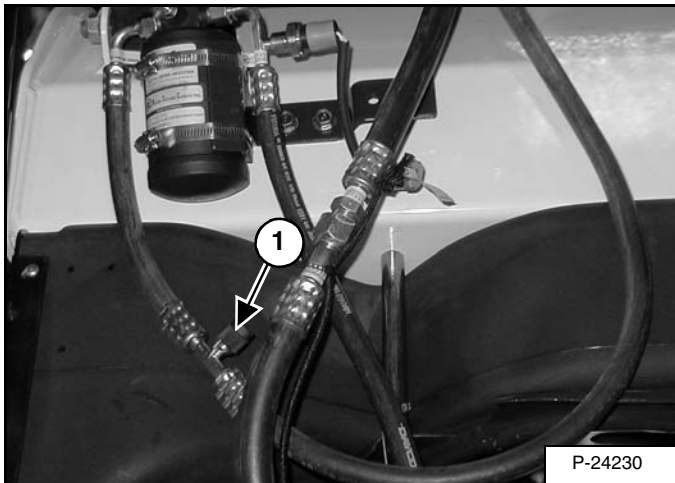

NOTE: Do not use this port (Item 1) [Figure 80-40-4] for testing or charging.

WARNING

In the event of a leak, wear safety goggles. Escaping refrigerant can cause severe injuries to eyes. In contact with a flame, R134a refrigerant gives a toxic gas.

W-2371-0500

Figure 80-40-5



IMPORTANT: Only A/C trained technicians should perform the reclaiming and recharging.

WARNING

HFC 134A refrigerant can be dangerous if not properly handled. Liquid 134A may cause blindness if it contacts the eyes and may cause serious frostbite if it contacts the skin.

- Gaseous 134A becomes lethal (phosgene) gas when it contacts open flame or very hot substances.
- **NEVER SMOKE** when there is the possibility of even small amounts of 134A in the air.

Any servicing work that involves release or addition of 134A to the system must be done by a competent refrigeration dealer who has the proper equipment, knowledge, and experience to service refrigeration equipment.

W-2373-0500

Use an approved recovery/charging unit [Figure 80-40-5] to evacuate the system.

COMPRESSOR (CONT'D)

Clutch Disassembly And Assembly

Figure 80-50-10

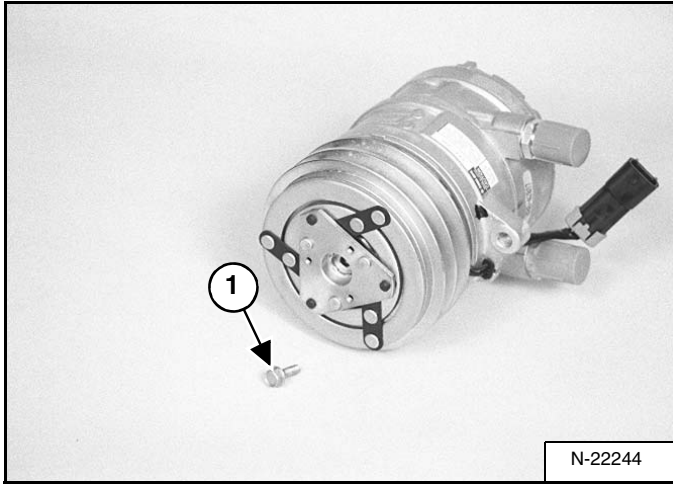

Remove the center armature bolt (Item 1) [Figure 80-50-10].

Installation: Tighten the armature bolt to 8 - 10 ft.-lb. (12 - 14 N•m) torque.

Figure 80-50-11

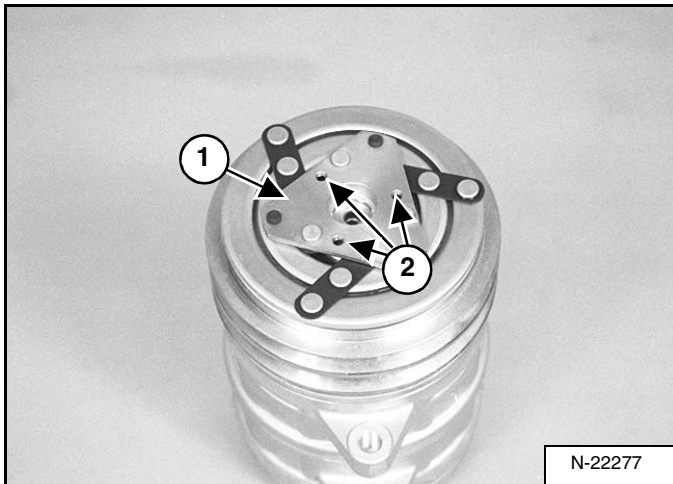

To remove the armature plate (Item 1) [Figure 80-50-11] from the clutch face, you must make an armature plate puller.

Figure 80-50-12

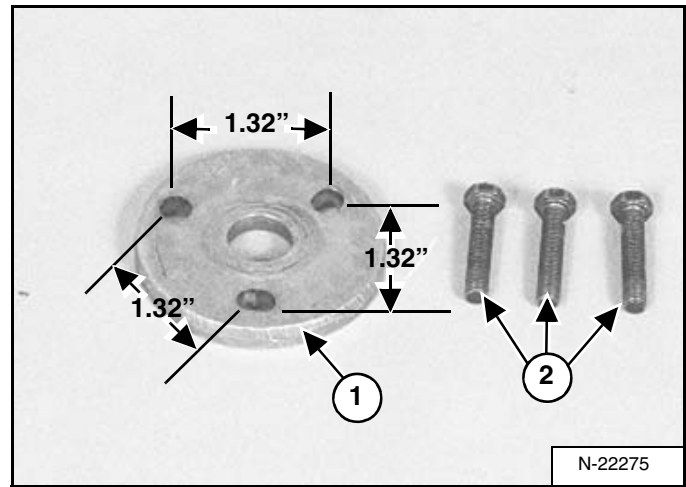

The armature plate puller, (Item 1) can be constructed by drilling three 10 mm holes in a flat circular plate, located 1.32 in. apart [Figure 80-50-12].

Attach the puller to the armature plate using three 8 mm bolts (Item 2) [Figure 80-50-12].

Figure 80-50-13



Turn the bolts into the three 8 mm holes (Item 2) [Figure 80-50-11] on the armature plate as shown in [Figure 80-50-13].

RECEIVER/DRIER (CONT'D)

Schraeder Valve Removal And Installation

Figure 80-70-8

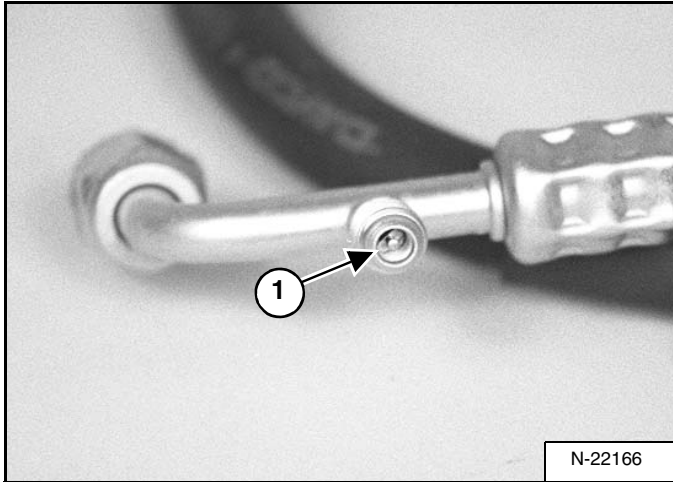

The schraeder valve (Item 1) [Figure 80-70-8] is located in the A/C high pressure hose and is located under the pressure switch.

Raise the loader lift arms and install an approved lift arm support device. (See Installing on Page 10-20-1.)

Raise the operator cab. (See Raising on Page 10-30-2.)

Remove the refrigerant from the A/C system.(See Reclamation And Charging With Recovery / Charging Unit on Page 80-40-2.)

Remove the pressure switch.

With a tire valve core removal tool, remove the valve core from the hose.

Replace with a new core.

HEATER COIL (CONT'D)

Removal And Installation With A/C (Cont'd)

Figure 80-120-4

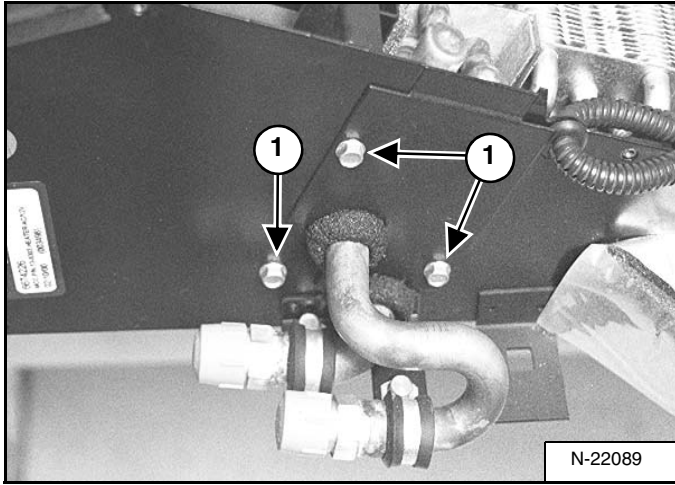

Remove the three mount bolts (Item 1) [Figure 80-120-4] and remove the mount plate from the end of the unit.

Remove the heater coil from the unit.

Figure 80-120-5

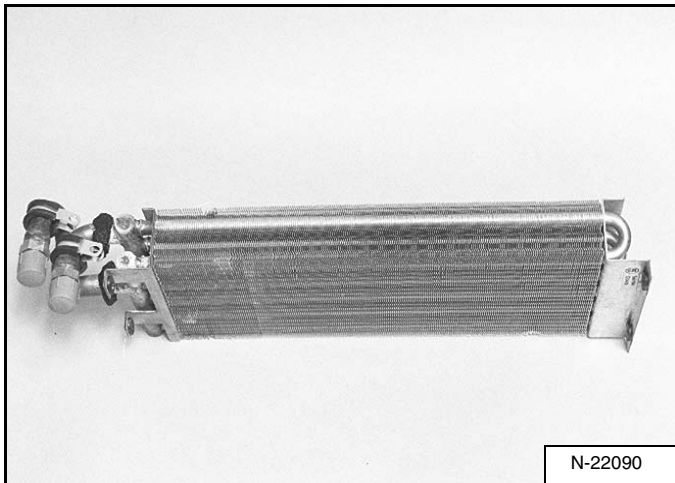

The heater coil [Figure 80-120-5] can be cleaned with low air or water pressure.

If the heater coil needs replacement it must be replaced as complete unit.



Bobcat®

TORQUE SPECIFICATIONS FOR BOLTS (CONT'D)**Torque For General Metric Bolts**

THREAD SIZE (DIA. X PITCH)	MATERIAL		
	HEAD MARK 4	HEAD MARK 7	HEAD MARK 10
M 5 x 0.8		3 - 4 ft.-lb. (4 - 5 N•m)	
M 6 x 1.0		6 - 7 ft.-lb. (8 - 9 N•m)	6 - 9 ft.-lb. (8 - 12 N•m)
M 8 x 1.25	6 - 9 ft.-lb. (8 - 12 N•m)	11 - 16 ft.-lb. (15 - 22 N•m)	18 - 25 ft.-lb. (24 - 34 N•m)
M 10 x 1.25	13 - 18 ft.-lb. (18 - 24 N•m)	22 - 30 ft.-lb. (30 - 41 N•m)	36 - 50 ft.-lb. (49 - 68 N•m)
M 12 x 1.25	22 - 30 ft.-lb. (30 - 41 N•m)	40 - 54 ft.-lb. (54 - 73 N•m)	69 - 87 ft.-lb. (94 - 118 N•m)
M 14 x 1.25	36 - 50 ft.-lb. (49 - 68 N•m)	58 - 80 ft.-lb. (79 - 108 N•m)	116 - 137 ft.-lb. (157 - 186 N•m)



Bobcat®



Bobcat®

CLICK HERE TO **DOWNLOAD** THE COMPLETE MANUAL

- Thank you very much for reading the preview of the manual.
- You can download the complete manual from: www.heydownloads.com by clicking the link below



- Please note: If there is no response to CLICKING the link, please download this PDF first and then click on it.

CLICK HERE TO **DOWNLOAD** THE COMPLETE MANUAL