



Bobcat®

EN

Service Manual

S100 Skid-Steer Loader

S/N A2G811001 & Above
S/N A8ET11001 - A8ET19999

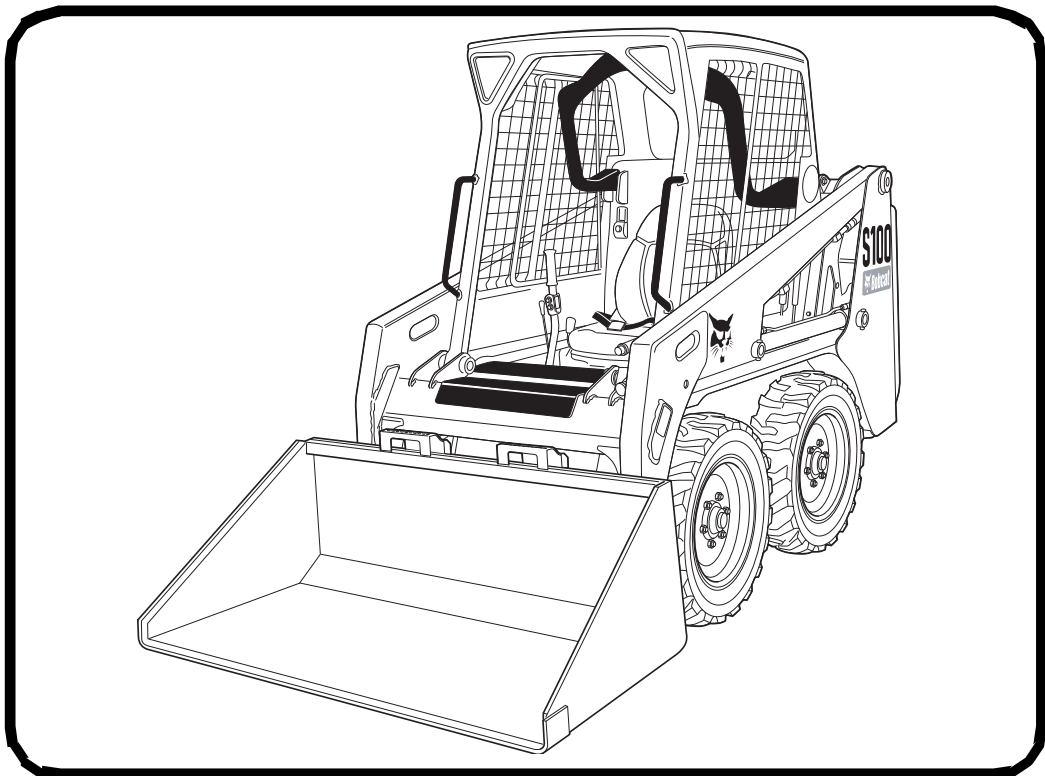

**EQUIPPED WITH
BOBCAT INTERLOCK
CONTROL SYSTEM (BICS)**



CLICK HERE TO **DOWNLOAD** THE COMPLETE MANUAL

- Thank you very much for reading the preview of the manual.
- You can download the complete manual from: www.heydownloads.com by clicking the link below



- Please note: If there is no response to CLICKING the link, please download this PDF first and then click on it.

CLICK HERE TO **DOWNLOAD** THE COMPLETE MANUAL

SAFETY INSTRUCTIONS

 Safety Alert Symbol
This symbol with a warning statement means: “Warning, be alert! Your safety is involved!” Carefully read the message that follows.

 WARNING

Instructions are necessary before operating or servicing machine. Read and understand the Operation & Maintenance Manual, Operator's Handbook and signs (decals) on machine. Follow warnings and instructions in the manuals when making repairs, adjustments or servicing. Check for correct function after adjustments, repairs or service. Untrained operators and failure to follow instructions can cause injury or death.

W-2003-0903

IMPORTANT

This notice identifies procedures which must be followed to avoid damage to the machine.

I-2019-0284

 DANGER

The signal word DANGER on the machine and in the manuals indicates a hazardous situation which, if not avoided, will result in death or serious injury.

D-1002-1107

 WARNING

The signal word WARNING on the machine and in the manuals indicates a potentially hazardous situation which, if not avoided, could result in death or serious injury.

W-2044-1107

The following publications provide information on the safe use and maintenance of the Bobcat machine and attachments:

- The Delivery Report is used to assure that complete instructions have been given to the new owner and that the machine is in safe operating condition.
- The Operation & Maintenance Manual delivered with the machine or attachment contains operating information as well as routine maintenance and service procedures. It is a part of the machine and can be stored in a container provided on the machine. Replacement Operation & Maintenance Manuals can be ordered from your Bobcat dealer.
- Machine signs (decals) instruct on the safe operation and care of your Bobcat machine or attachment. The signs and their locations are shown in the Operation & Maintenance Manual. Replacement signs are available from your Bobcat dealer.
- An Operator's Handbook fastened to the operator cab. It's brief instructions are convenient to the operator. The handbook is available from your dealer in an English edition or one of many other languages. See your Bobcat dealer for more information on translated versions.
- The AEM Safety Manual delivered with the machine gives general safety information.
- The Service Manual and Parts Manual are available from your dealer for use by mechanics to do shop-type service and repair work.
- The Skid-Steer Loader Operator Training Course is available through your local dealer or at www.training.bobcat.com or www.bobcat.com. This course is intended to provide rules and practices of correct operation of the Skid-Steer Loader. The course is available in English and Spanish versions.
- Service Safety Training Courses are available from your Bobcat dealer or at www.training.bobcat.com or www.bobcat.com. They provide information for safe and correct service procedures.
- The Skid-Steer Loader Safety Video is available from your Bobcat dealer or at www.training.bobcat.com or www.bobcat.com.

SI SSL-0308 SM

LIFTING AND BLOCKING THE LOADER

Procedure

Figure 10-10-1

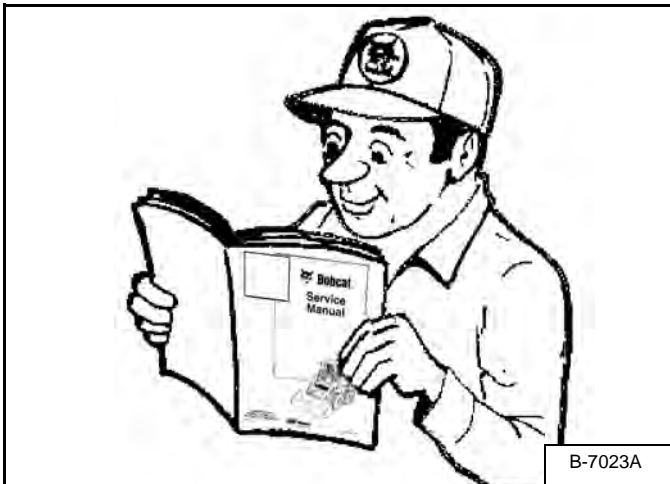

WARNING

AVOID INJURY OR DEATH

Instructions are necessary before operating or servicing machine. Read and understand the Operation & Maintenance Manual, Operator's Handbook and signs (decals) on machine. Follow warnings and instructions in the manuals when making repairs, adjustments or servicing. Check for correct function after adjustments, repairs or service. Untrained operators and failure to follow instructions can cause injury or death.

W-2003-0807

Always park the loader on a level surface.

WARNING

Put jackstands under the front axles and rear corners of the frame before running the engine for service. Failure to use jackstands can allow the machine to fall or move and cause injury or death.

W-2017-0286

Figure 10-10-2



Put the floor jack under the rear of the loader.

Lift the rear of the loader and install jack stands [Figure 10-10-2].

Figure 10-10-3

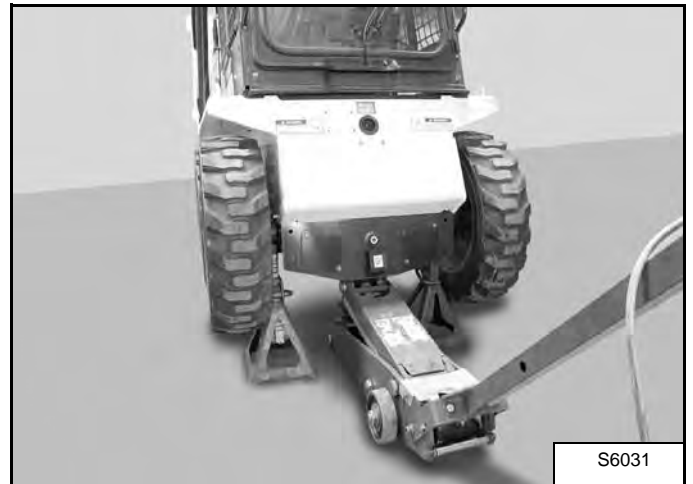

Put the floor jack under the front of the loader [Figure 10-10-3].

Lift the front of the loader and put jack stands under the axle tubes [Figure 10-10-3].

NOTE: Make sure the jack stands do not touch the tires. Make sure tires clear floor or any obstacles.

TOWING THE LOADER

Procedure

Because of the design of the loader, there is not a recommended towing procedure.

- The loader can be lifted onto a transport vehicle.
- The loader can be skidded a short distance to move for service (EXAMPLE: Move onto a transport vehicle.) without damage to the hydrostatic system. (The wheels will not turn.) There might be slight wear to the wheels when the loader is skidded.

The towing chain (or cable) must be rated at 1 and 1/2 times the weight of the loader. (See Weights on Page SPEC-10-2.)

REMOTE START TOOL (SERVICE TOOL) KIT - 6689779 (CONT'D)

Loader Service Tool Harness - 6689747

Figure 10-61-3

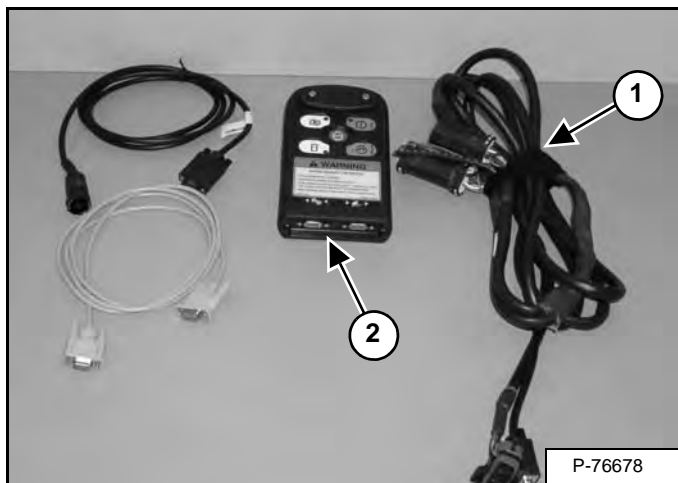

The loader service tool harness (Item 1) is used to connect the remote start tool (service tool) (Item 2) [Figure 10-61-3] to the electrical system on the loader.

Figure 10-61-4



Loaders without an attachment control harness, remove the loader harness cap (Item 1) [Figure 10-61-4] and connect the Loader Service Tool Harness, from the Remote Start Tool (Service Tool), to the loader harness connector.

Figure 10-61-5

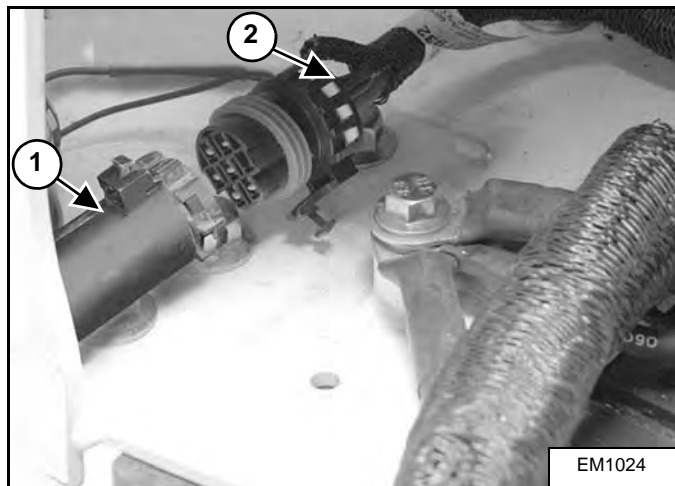

Loaders with an attachment control harness (7 pin or 14 pin), the attachment harness (Item 1) must be disconnected from the loader harness (Item 2) [Figure 10-61-5].

When the remote start procedure is completed, replace the loader connector cap (Item 1) [Figure 10-61-4] or reconnect the attachment control harness to the loader harness [Figure 10-61-5].

ENGINE COOLING SYSTEM

Check the cooling system every day to prevent overheating, loss of performance or engine damage.

Cleaning

Open the rear door and raise the rear grill.

NOTE: Be careful when raising and lowering the rear grill so that it does not fall on the radiator and damage the fins.

Figure 10-90-1

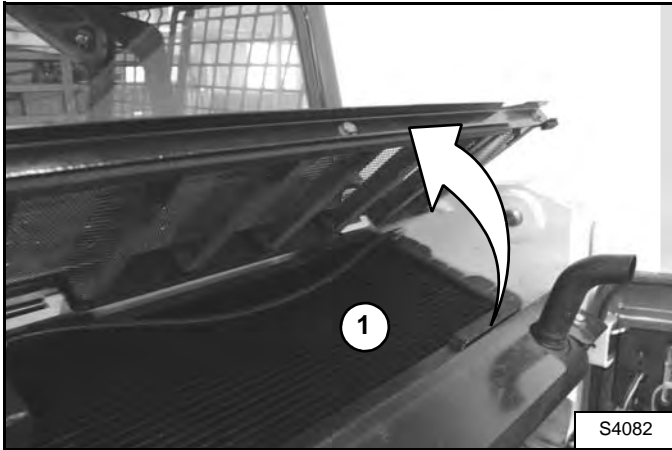

Use low air pressure or water pressure to clean the top of the radiator (Item 1) [Figure 10-90-1].

Check the cooling system for leaks.

Lower the rear grill and close the rear door.

Checking Level

Open the rear door and remove the rear grill (See REAR GRILL on Page 50-60-1).

WARNING

AVOID INJURY OR DEATH

Wear safety glasses to prevent eye injury when any of the following conditions exist:

- When fluids are under pressure.
- Flying debris or loose material is present.
- Engine is running.
- Tools are being used.

W-2019-0907

Figure 10-90-2

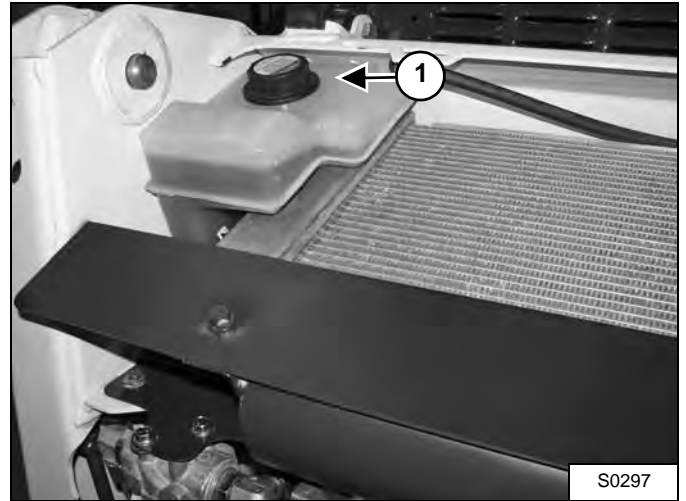

Remove the coolant fill cap (Item 1) [Figure 10-90-2]. Check the coolant level. The level markers are on the tank. Coolant must be at the bottom marker when the engine is cold and on the top marker when hot.

Use a refractometer to check the condition of propylene glycol in your cooling system.

Close the rear door before operating the loader.

IMPORTANT

AVOID ENGINE DAMAGE

Always use the correct ratio of water to antifreeze.

Too much antifreeze reduces cooling system efficiency and may cause serious premature engine damage.

Too little antifreeze reduces the additives which protect the internal engine components; reduces the boiling point and freeze protection of the system.

Always add a premixed solution. Adding full strength concentrated coolant can cause serious premature engine damage.

I-2124-0497

FINAL DRIVE TRANSMISSION (CHAINCASE)

Checking And Adding Oil

The chaincase contains the final drive sprockets and chains. Use the same type of oil as the hydraulic / hydrostatic system. (See Fluid Specifications on Page SPEC-10-5.)

Stop the loader on a level surface.

Stop the engine.

Figure 10-130-1

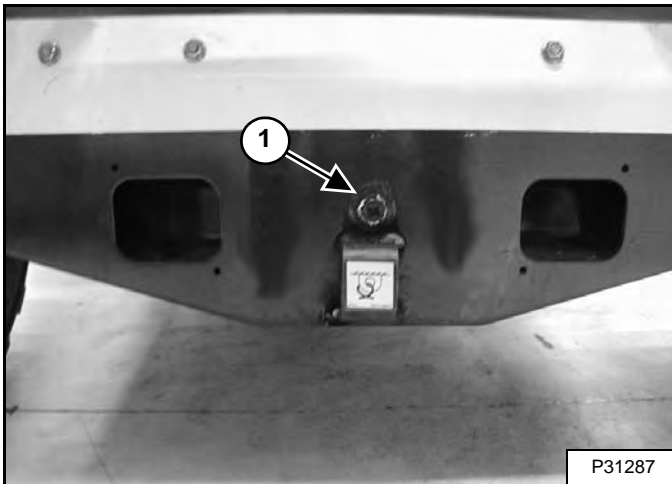

Remove the check plug (Item 1) **[Figure 10-130-1]** from the front of the chaincase housing.

If oil can be reached with the tip of your finger through the hole, the oil level is correct.

If the level is low, add lubricant through the check plug hole until it reaches the desired level.

Install and tighten the plug.

Removing And Replacing Oil

Remove the check plug (Item 1) **[Figure 10-130-1]** from the front of the chaincase housing.

Figure 10-130-2



Use a pump to suction the oil from the chaincase **[Figure 10-130-2]**.

Recycle or dispose of the used oil in an environmentally safe manner.

Add new oil until you can reach the oil with the tip of your finger through the hole.

Install and tighten the plug.

SPARK ARRESTOR MUFFLER

Cleaning Procedure

See the SERVICE SCHEDULE for service interval for cleaning the spark arrestor muffler. (See SERVICE SCHEDULE on Page 10-70-1.)

Do not operate the loader with a defective exhaust system.

Stop the engine and open the rear door.

Figure 10-170-1

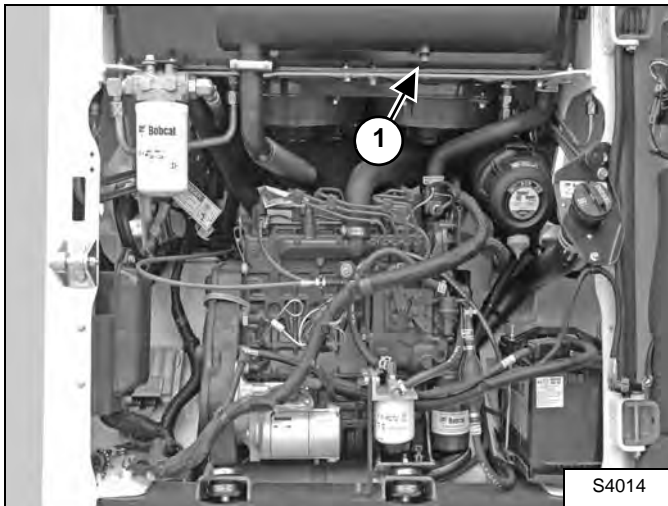

Remove the plug (Item 1) [Figure 10-170-1] from the bottom of the muffler.

WARNING

When the engine is running during service, the steering levers must be in neutral and the parking brake engaged. Failure to do so can cause injury or death.

W-2006-0284

Start the engine and run for about 10 seconds while a second person, wearing safety goggles, holds a piece of wood over the outlet of the muffler. This will force contaminants out through the cleanout hole.

Stop the engine.

Install and tighten the plug.

Close the rear door.

WARNING

AVOID INJURY OR DEATH

When an engine is running in an enclosed area, fresh air must be added to avoid concentration of exhaust fumes. If the engine is stationary, vent the exhaust outside. Exhaust fumes contain odorless, invisible gases which can kill without warning.

W-2050-0807

WARNING

Stop engine and allow the muffler to cool before cleaning the spark chamber. Wear safety goggles. Failure to obey can cause serious injury.

W-2011-1285

WARNING

Never use machine in atmosphere with explosive dust or gases or where exhaust can contact flammable material. Failure to obey warnings can cause injury or death.

W-2068-1285

HYDRAULIC SYSTEM

BOB-TACH (POWER) BLOCK	20-110-1
Description	20-110-1
Disassembly And Assembly	20-110-3
Removal And Installation.	20-110-1
BUCKET POSITION VALVE	20-100-1
Description	20-100-1
Disassembly And Assembly	20-100-5
Removal And Installation.	20-100-2
Solenoid Removal And Installation	20-100-1
Solenoid Testing	20-100-2
CYLINDER (BOB-TACH)	20-22-1
Disassembly and Assembly.	20-22-4
Parts Identification.	20-22-3
Removal And Installation.	20-22-2
Testing.	20-22-1
CYLINDER (LIFT)	20-20-1
Disassembly And Assembly	20-20-4
Parts Identification.	20-20-3
Removal And Installation.	20-20-2
Testing.	20-20-1
CYLINDER (TILT)	20-21-1
Disassembly And Assembly	20-21-4
Parts Identification.	20-21-3
Removal And Installation.	20-21-1
Testing.	20-21-1
FRONT AUXILIARY HYDRAULIC COUPLERS	20-120-1
Description	20-120-1
Removal And Installation.	20-120-1

Continued On Next Page

HYDRAULIC SYSTEM INFORMATION (CONT'D)

Troubleshooting

The following troubleshooting chart is provided for assistance in locating and correcting problems which are most common. Many of the recommended procedures must be done by authorized Bobcat service personnel only.

If the service code appears in the left instrument panel, refer to the Electrical Service Manual for the probable cause.



WARNING

Check for correct function after adjustments, repairs or service. Failure to make correct repairs or adjustments can cause injury or death.

W-2004-1285

PROBLEM	CAUSE
The hydraulic system will not operate.	1, 2, 3, 5, 8
Slow hydraulic system action.	1, 3, 4, 6, 8
Hydraulic action is not smooth.	1, 4, 5, 6, 7
Lift arms go up slowly at full engine RPM.	1, 3, 4, 6, 7, 8, 9
The lift arms or Bob-Tach will move when the pedal is in neutral position.	4
The lift arms come down with the pedal in the neutral position.	4, 9, 10, 11
bypass valve stuck.	12
bypass valve stem bent or broke.	13

KEY TO CORRECT THE CAUSE
1. The fluid level is not correct.
2. The pedal linkage is disconnected.
3. The hydraulic pump has damage.
4. The pedal linkage is not adjusted correctly.
5. Relief valve is not at the correct pressure.
6. Suction leak on the inlet side of the hydraulic pump.
7. Fluid is cold. Wrong viscosity fluid.
8. Using the loader for more than its rated capacity.
9. Internal leak in the lift cylinder(s).
10. External leak from the lift cylinder(s).
11. Damaged lift spool.
12. Rotate shaft.
13. Replace manual spool cartridge.

CYLINDER (TILT) (CONT'D)

Parts Identification

- | | |
|-------------|-----------------|
| 1. Piston | 9. Back-up ring |
| 2. O-ring | 10 O-ring |
| 3. Seal | 11. Head |
| 4. Nut | 12. Wiper Seal |
| 5. Plug | 13. Rod Seal |
| 6. O-ring | 14. Rod |
| 7. Cylinder | |
| 8. O-ring | |

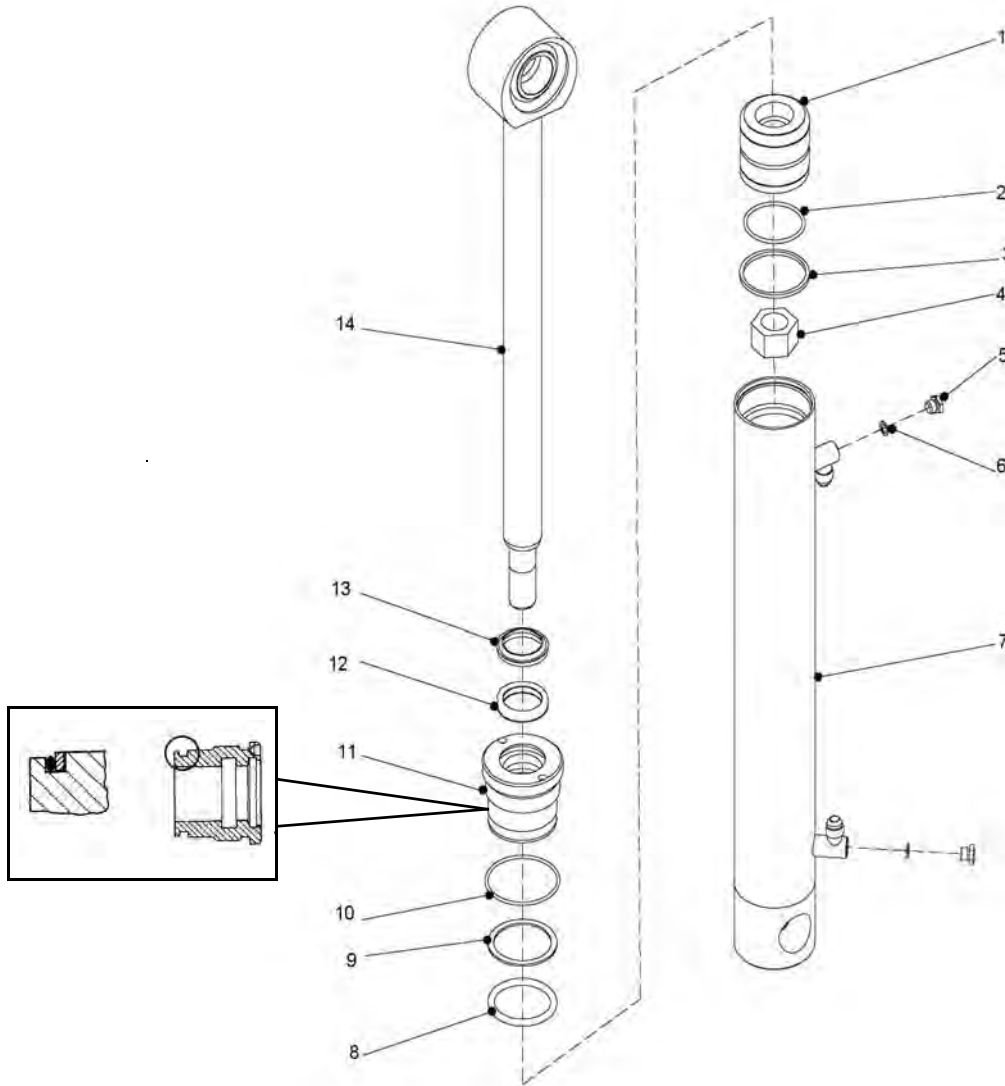

S4378

MAIN RELIEF VALVE

Description

The main relief valve limits the hydraulic system pressure by opening at a certain pressure and allowing the hydraulic oil to flow back to the hydraulic reservoir. (See Hydraulic System on Page SPEC-10-3.)

The main relief valve is adjustable and is located on the hydraulic control valve near the bottom, facing the front of the loader.

Testing

IMPORTANT

The hydraulic tester must be in the fully open position before you start the engine.

I-2024-0284

! WARNING

When the engine is running during service, the steering levers must be in neutral and the parking brake engaged. Failure to do so can cause injury or death.

W-2006-0284

! WARNING

Put jackstands under the front axles and rear corners of the frame before running the engine for service. Failure to use jackstands can allow the machine to fall or move and cause injury or death.

W-2017-0286

The tools listed will be needed to do the following procedure:

MEL10003 - Hydraulic Tester

MEL10006 - Hydraulic Test Kit

Turn the key switch to the OFF position. To release the hydraulic pressure at the front auxiliary quick couplers push the couplers into the coupler block and hold for three seconds.

Lift and block the loader (See LIFTING AND BLOCKING THE LOADER on Page 10-10-1.)

Figure 20-30-1

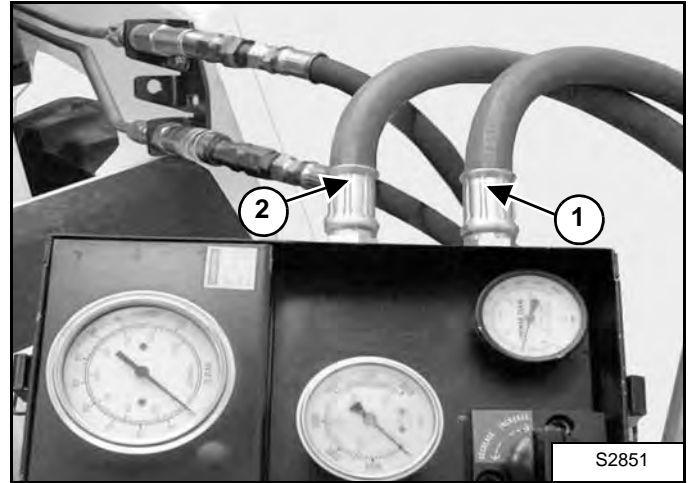

Connect the IN port (Item 1) [Figure 20-30-1] of the hydraulic tester to the bottom (female) quick coupler on the loader.

Connect the OUT port (Item 2) [Figure 20-30-1] of the hydraulic tester to the top (male) quick coupler on the loader.

Figure 20-30-2



Move the handle all the way to the right, to put the control valve in the locked position for a constant flow of hydraulic fluid under pressure to the quick couplers [Figure 20-30-2].

Move the handle out of the locked position before leaving the operator cab.

HYDRAULIC CONTROL VALVE (CONT'D)

Rubber Boot Removal And Installation

Figure 20-40-20

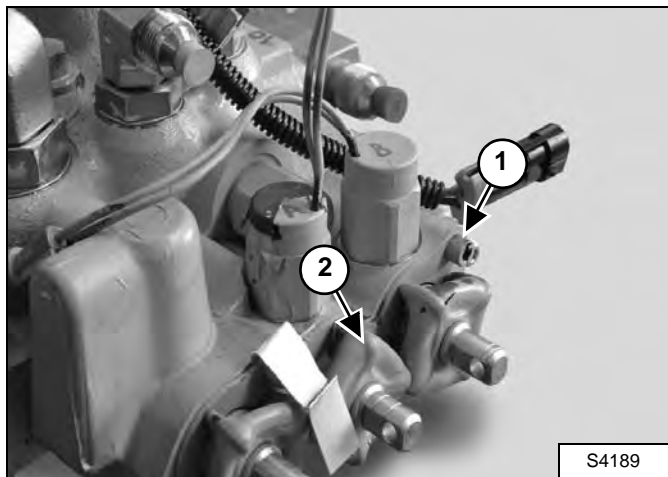

Remove the four screws (Item 1) [Figure 20-40-20] on the rubber boot retainer plate.

Installation: Tighten the screws to 90-100 in.-lb. (10-11,3 N•m) torque.

Remove the rubber boots (Item 2) [Figure 20-40-20] from the retainer plate.

End Cap / Spool Lock Block Removal And Installation

Figure 20-40-21

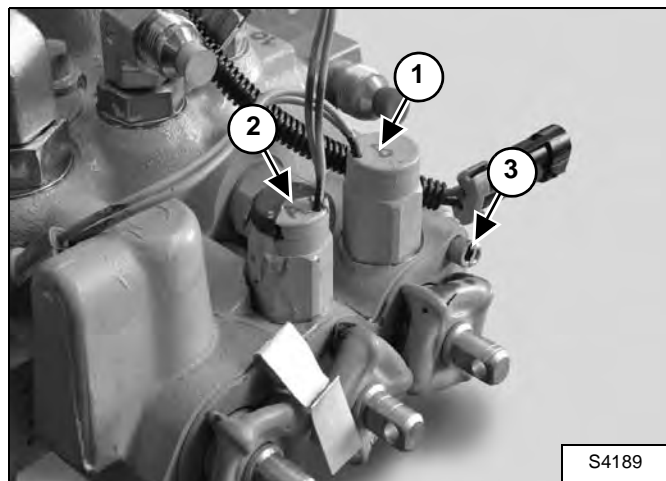

Remove the lift spool lock solenoid (Item 1) and the tilt spool lock solenoid (Item 2) [Figure 20-40-21] from the end cap / spool lock block.

Remove the four end cap / spool lock block mount screws (Item 3) [Figure 20-40-21].

Installation: Tighten the screws to 90-100 in.-lb. (10-11,3 N•m) torque.

Remove the rubber boots and retainer plate from the lift and tilt spools.

Figure 20-40-22

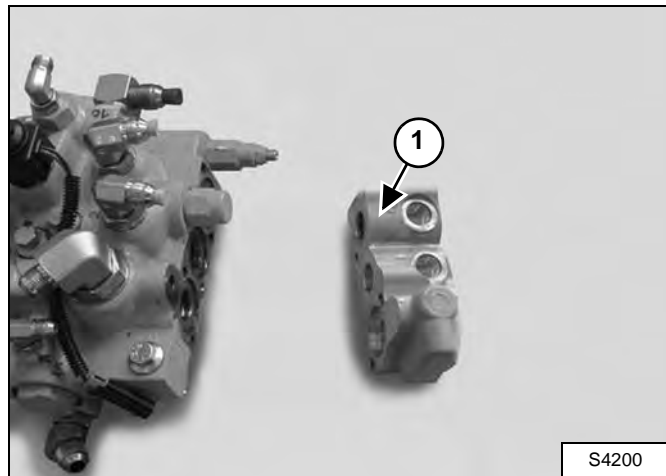

Remove the end cap / spool lock block (Item 1) [Figure 20-40-22] from the control valve.

HYDRAULIC CONTROL VALVE (CONT'D)

Tilt Spool Removal And Installation

Remove the lift and tilt end cap / spool lock block. (See End Cap / Spool Lock Block Removal And Installation on Page 20-40-9.)

Figure 20-40-59

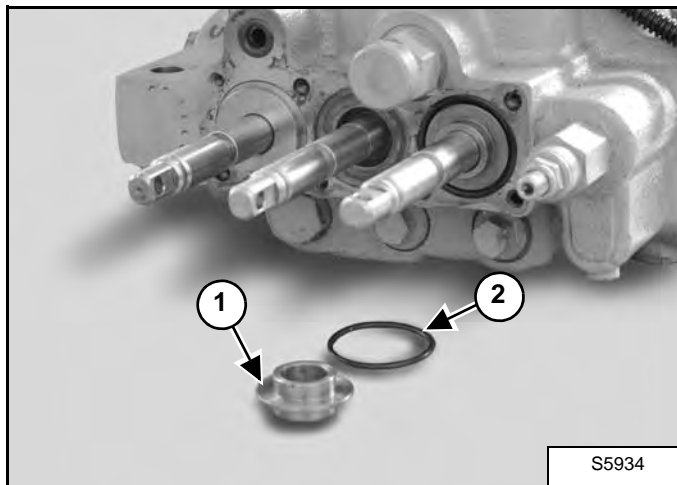

Remove the spacer (Item 1) and O-ring (Item 2) [Figure 20-40-59] from the tilt spool.

Figure 20-40-60

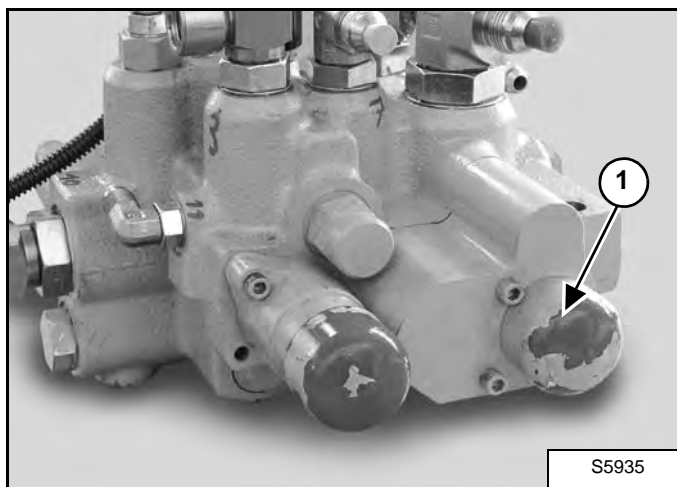

Remove the end cap (Item 1) [Figure 20-40-60].

Figure 20-40-61

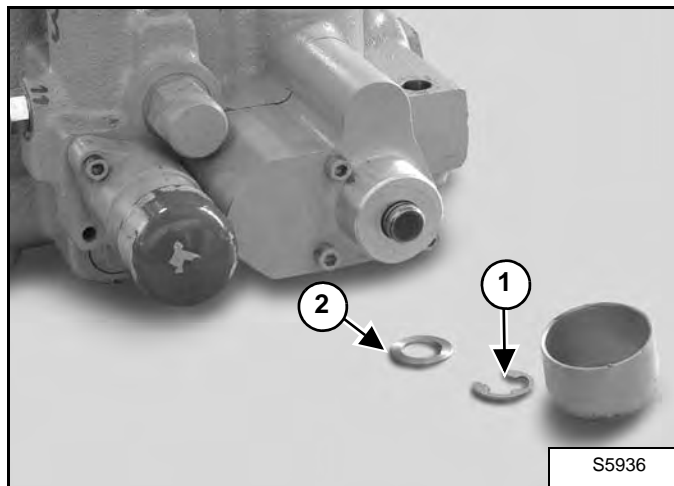

Use a screwdriver to remove the snap ring (Item 1) [Figure 20-40-61].

Remove the washer (Item 2) [Figure 20-40-61].

Figure 20-40-62

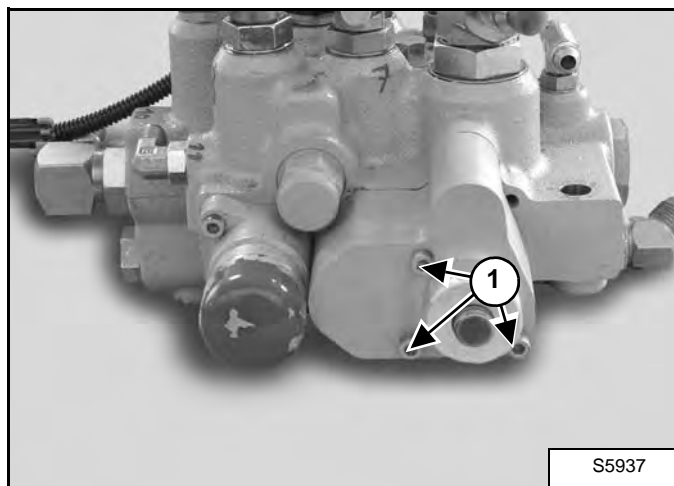

Remove the three bolts (Item 1) [Figure 20-40-62] from the spool centering block and remove the spool centering block.

Installation: Tighten the bolts to 90-100 in.-lb. (10-11,3 N•m) torque.

HYDRAULIC CONTROL VALVE (CONT'D)

Solenoid Removal And Installation

Figure 20-40-98

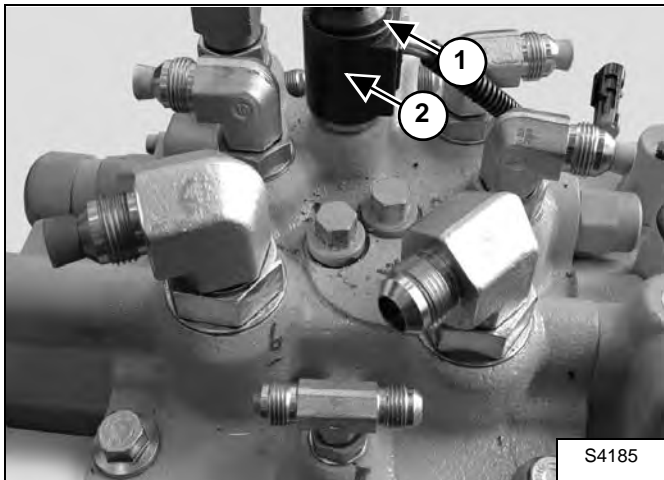

Remove the nut (Item 1) [Figure 20-40-98] from the solenoid stem.

Installation: Tighten the nut to 53 in.-lb. (6 N•m) torque.

Remove the solenoid coil (Item 2) [Figure 20-40-98].

Figure 20-40-99

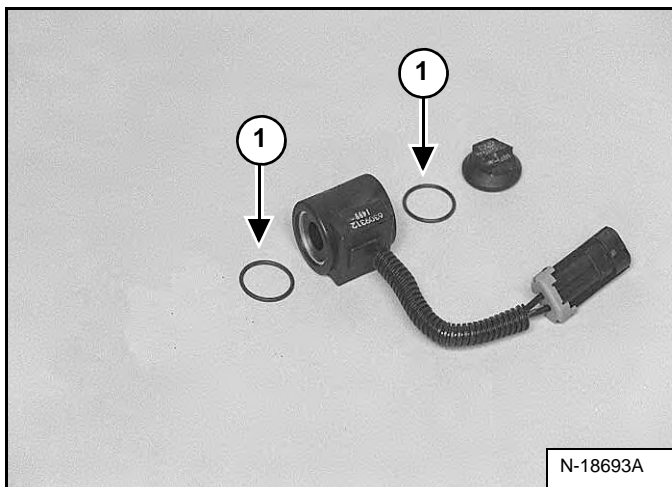

Remove the O-rings (Item 1) [Figure 20-40-99] from both ends of the solenoid coil.

Use an Ohm meter to measure the solenoid coil resistance.

The correct resistance for the coil is **9.79 ± 0.29 Ohms**.

Figure 20-40-100

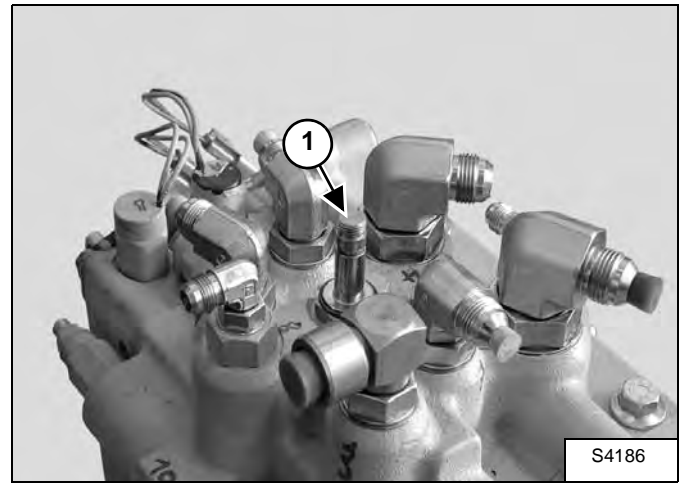

Remove the solenoid stem (Item 1) [Figure 20-40-100].

Installation: Lubricate the O-rings and tighten the stem to 20-24 ft.-lb. (27-33 N•m) torque.

Figure 20-40-101

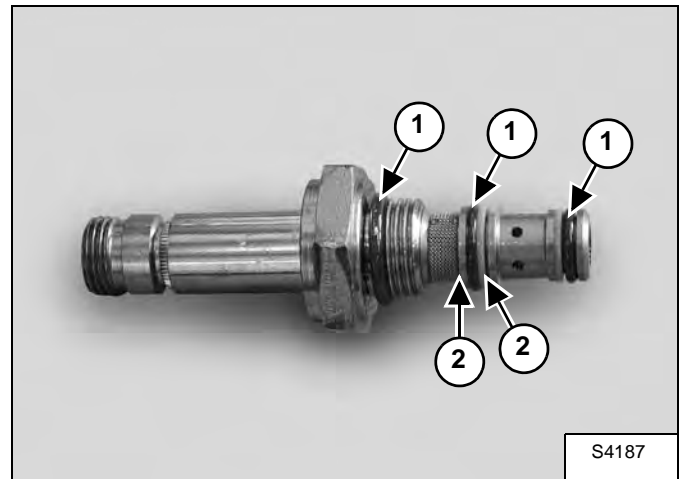

Remove the O-rings (Item 1) and back-up rings (Item 2) [Figure 20-40-101] from the cartridge.

Clean all parts in solvent and dry with compressed air.

Inspect all parts for wear and replace any showing excessive wear.

NOTE: The screen (Item 3) [Figure 20-40-101] may be cleaned with solvent. If it is torn or worn it needs to be replaced.

Use only new O-rings and apply oil to all O-rings and back-up rings before installation.

Install new O-rings (Item 1) [Figure 20-40-99] and [Figure 20-40-101] and new back-up rings (Item 2) [Figure 20-40-101] on the solenoid stem.

HYDRAULIC PUMP (CONT'D)

Direct Pump Test (Cont'd)

IMPORTANT

The hydraulic tester must be in the fully open position before you start the engine.

I-2024-0284

Figure 20-60-4

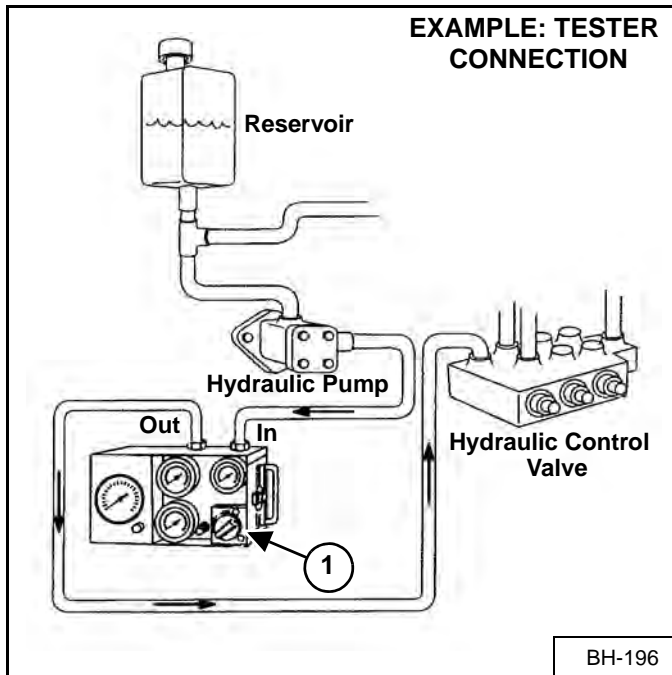

Sample tester connection shown [Figure 20-60-4].

Start the engine and run at low idle RPM. Make sure the tester is connected correctly. If no flow is indicated on the tester, the hoses are connected wrong. With the hoses connected correctly, increase the engine speed to full RPM*.

Warm the fluid to 140°F (60°C) by turning the restrictor control (Item 1) [Figure 20-60-4] on the tester to about 1000 PSI (68,95 bar).

DO NOT exceed system relief pressure. Open the restrictor control and record the free flow (GPM) at full RPM*.

Push the maximum / variable flow switch (on the remote start tool) to engage the front auxiliary hydraulics, the light will come ON. Push the button (on the right control lever) for fluid flow to the quick coupler (fluid pressure will go over main relief). Record the highest pressure (PSI) and

flow (GPM). The high pressure flow must be at least 80% of free flow.

$$\% = \frac{\text{HIGH PRESSURE FLOW (GPM)}}{\text{FREE FLOW (GPM)}} \times 100$$

A low percentage may indicate a failed pump.

*Refer to (See Hydraulic System on Page SPEC-10-3.) for system relief pressure and full RPM.

Direct Pump Test (Charge Section)

The tools listed will be needed to do the following procedure:

- MEL1563 - Remote Start Tool
- MEL10103 - Hydraulic Tester
- MEL10106 - Hydraulic Test Kit
- 6661247 - Filter Assembly
- 17 KB 1212 - Elbow Fitting
- 15 KB 1212 - Straight Fitting
- 15 KB 0812 - Reducer Fitting

WARNING

Put jackstands under the front axles and rear corners of the frame before running the engine for service. Failure to use jackstands can allow the machine to fall or move and cause injury or death.

W-2017-0286

Lift and block the loader (See LIFTING AND BLOCKING THE LOADER on Page 10-10-1.)

Raise the lift arms and install an approved lift arm support device (See LIFT ARM SUPPORT DEVICE on Page 10-20-1.)

WARNING

Never work on a machine with the lift arms up unless the lift arms are secured by an approved lift arm support device. Failure to use an approved lift arm support device can allow the lift arms or attachment to fall and cause injury or death.

W-2059-0598

HYDRAULIC PUMP (CONT'D)

Disassembly And Assembly (Cont'd)

Figure 20-60-31

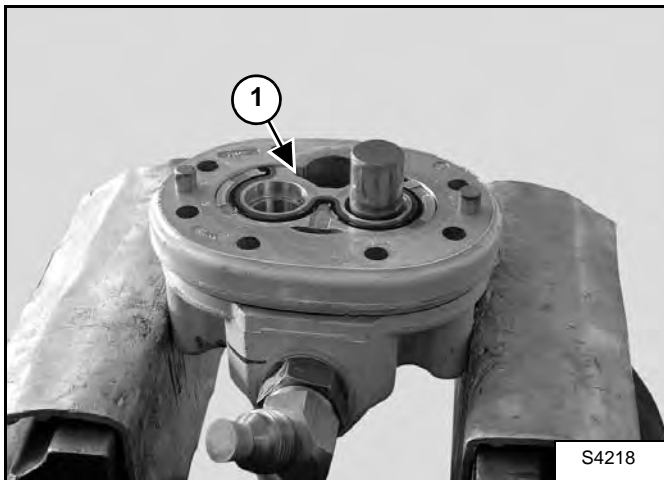

Remove the wear plate (Item 1) [Figure 20-60-31] from the pump lower section.

Figure 20-60-32



Remove the load and preload seals (Item 1) [Figure 20-60-23] onto the wear plate.

Figure 20-60-33

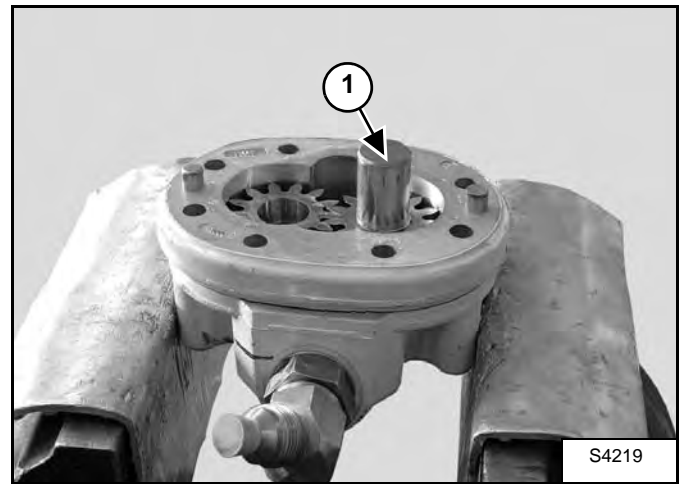
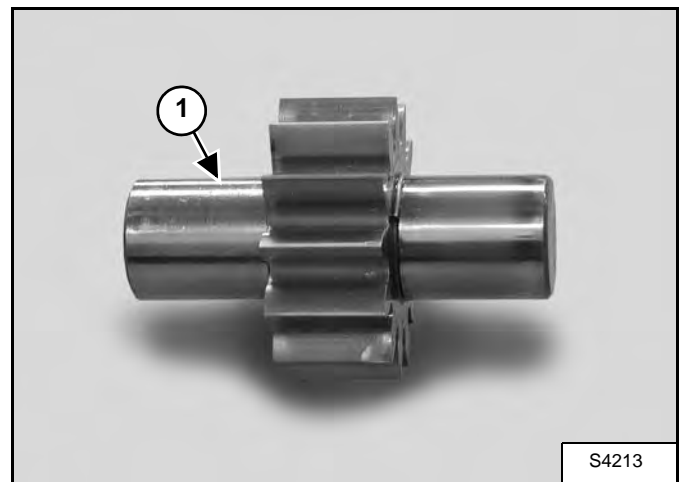

Figure 20-60-34



Remove the gear and axle (Item 1) [Figure 20-60-33] and [Figure 20-60-34] from the pump lower section.

Inspect the gear and axle (Item 1) [Figure 20-60-34] for wear. Replace if needed.

BUCKET POSITION VALVE (CONT'D)

Removal And Installation (Cont'd)

Figure 20-100-6

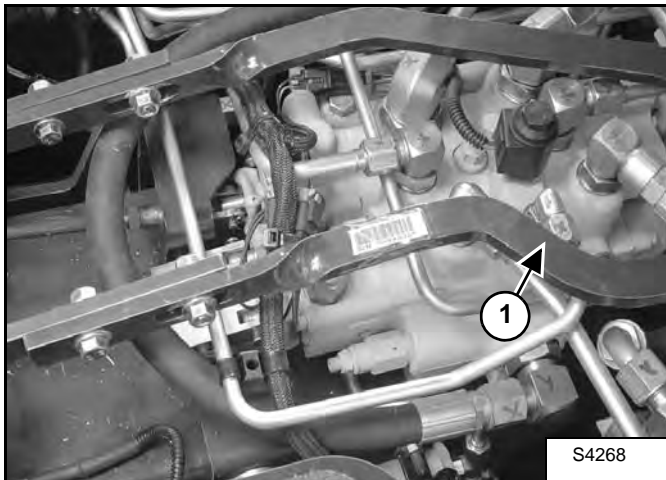

Remove the left steering linkage by removing the bolts and nuts on both ends of the steering linkage [Figure 20-100-6].

NOTE: Before disconnecting the hydraulic tubelines from the bucket position valve, first mark the tubelines and the fittings of the bucket position valve to make sure the tubelines will be put on the right fitting while reconnecting the tubelines.

Figure 20-100-7

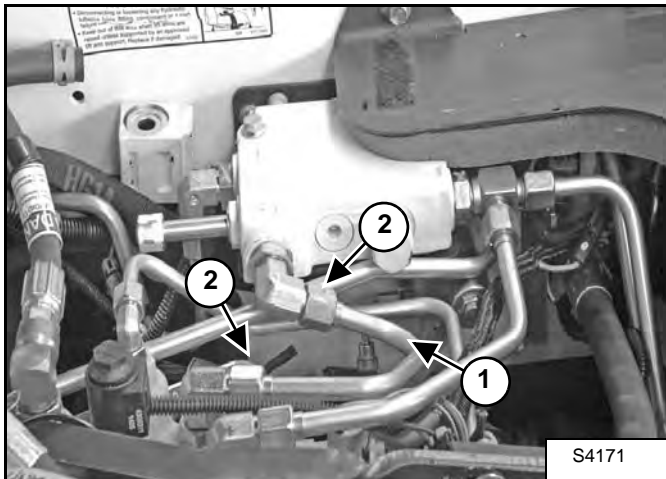

Remove the hydraulic tubeline (Item 1) by loosening the nuts (Item 2) [Figure 20-100-7]. Cap the fittings and tubeline after disconnection.

Figure 20-100-8

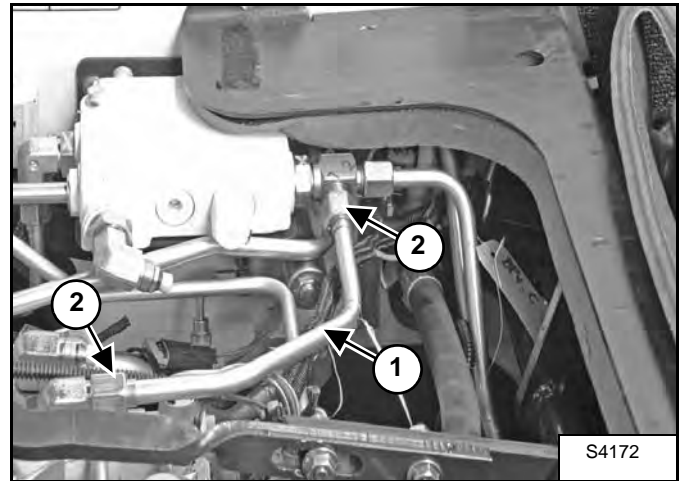

Remove the hydraulic tubeline (Item 1) by loosening the nuts (Item 2) [Figure 20-100-8]. Cap the tubeline and the fittings after disconnection.

Figure 20-100-9

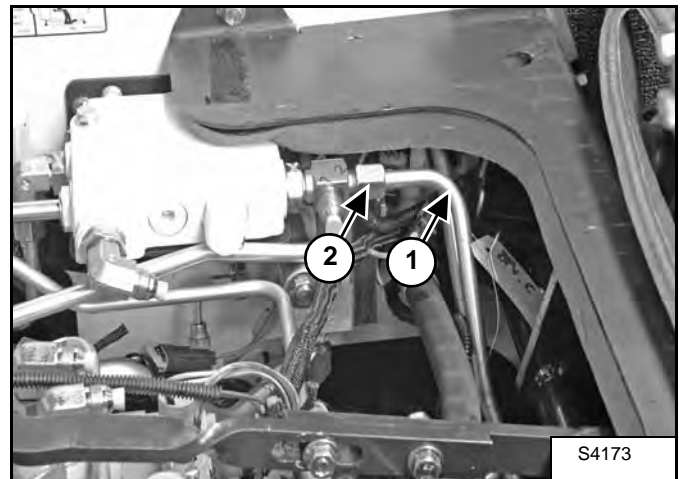

Disconnect the hydraulic tubeline (Item 1) by loosening the nut (Item 2) [Figure 20-100-9]. Cap the tubeline and the fitting after disconnection.

FRONT AUXILIARY HYDRAULIC COUPLERS

Description

The front auxiliary hydraulic couplers supply hydraulic flow for various attachments.

The front auxiliary hydraulic couplers are located at the front of the machine on the left side arm.

Removal And Installation

IMPORTANT

When repairing hydrostatic and hydraulic systems, clean the work area before disassembly and keep all parts clean. Always use caps and plugs on hoses, tubelines and ports to keep dirt out. Dirt can quickly damage the system.

I-2003-0888

Figure 20-120-1

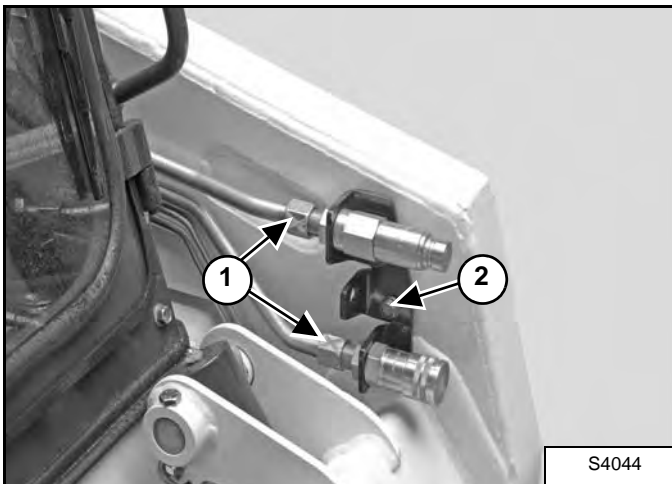

Disconnect the auxiliary tubelines (Item 1) [Figure 20-120-1] from the coupler frame.

Remove the mounting bolt (Item 2) [Figure 20-120-1].

HYDROSTATIC MOTOR (CONT'D)

Disassembly And Assembly (Cont'd)

Figure 30-20-15

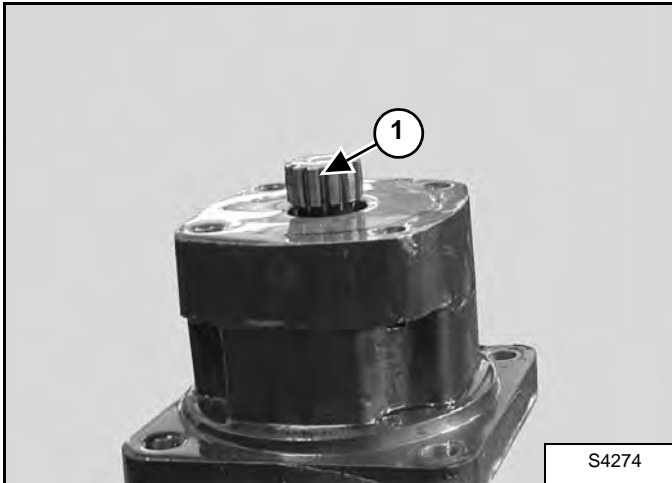

Remove the drive shaft (Item 1) [Figure 30-20-15] from the hydrostatic motor by pulling it out.

Turn the hydrostatic motor upside down.

Figure 30-20-16

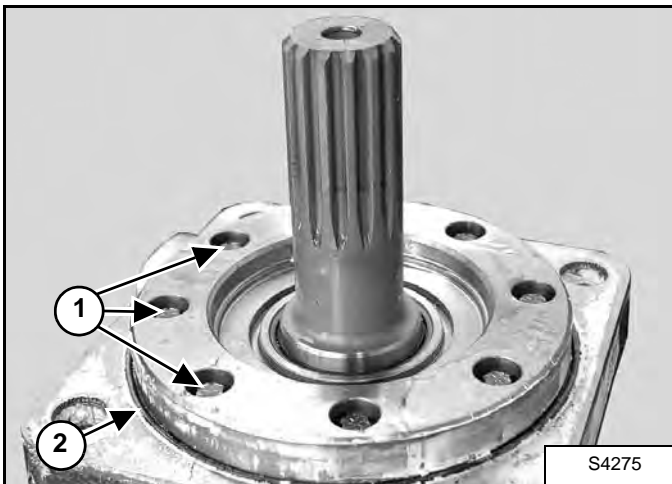

Remove the plate from the drive shaft by removing the eight bolts (Item 1) [Figure 30-20-16].

Remove the O-ring (Item 2) [Figure 30-20-16] and inspect for wear. Replace if needed.

Installation: Pretighten the eight bolts to 50 ft.-lb. (6 N•m), then torque screws to 300 ft.-lb.(34 N•m).

Figure 30-20-17

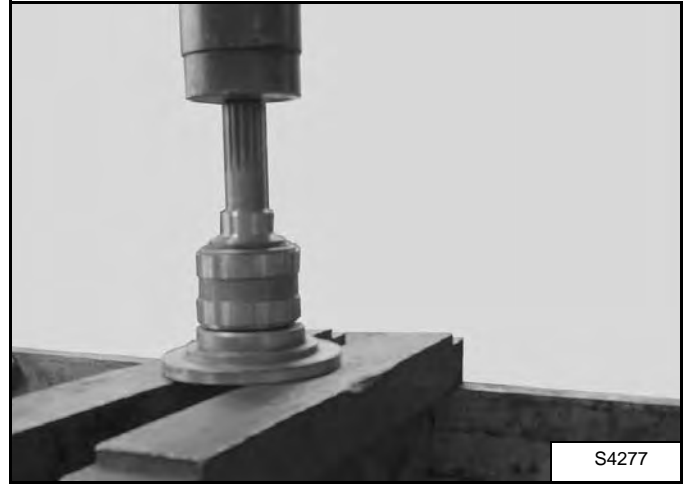

Installation: Use a hydraulic press to install the drive shaft in the housing [Figure 30-20-17].

Figure 30-20-18

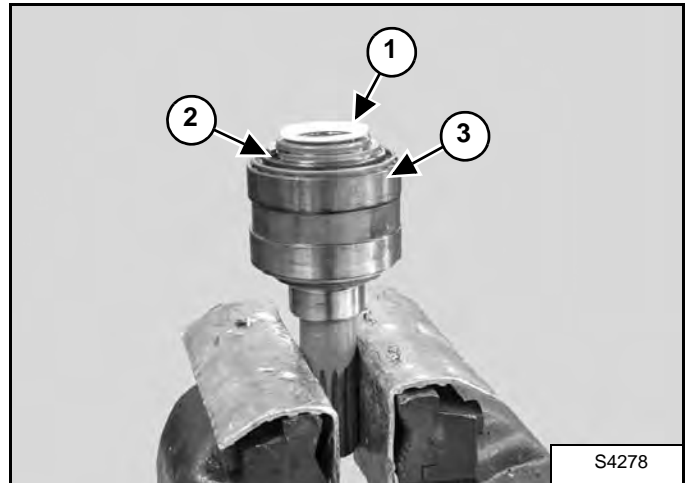

Remove the seal (Item 1) [Figure 30-20-18] from the drive shaft and inspect for wear. Replace if needed.

Remove the snap ring (Item 2) [Figure 30-20-18] from the drive shaft.

Remove the upper bearing (Item 3) [Figure 30-20-18] from the drive shaft by pulling it back.

HYDROSTATIC PUMP (CONT'D)

Parts Identification

1. Bolt (2)
2. Washer
3. O-ring
4. Coupler
5. O-ring
6. Replenishing/High Pressure Relief Valve
7. Pin
8. Bearing
9. Valve Plate
10. Gasket
11. Block
12. Wear Plate
13. Swash plate
14. Tapered Roller Bearing
15. Plug
16. O-ring
17. Housing
18. O-ring
19. Bearing Race
20. Cover
21. Washer
22. Bolt (6)
23. Bearing
24. Crush Ring
25. Seal
26. Cover
27. Shaft (For Left Pump)
28. Key
29. Retainer Ring
30. Bearing Thrust
31. Bearing
32. Washer
33. Seal
34. Retainer Ring
35. Shaft (For Right Pump)
36. O-ring
37. Charge Pressure Relief Valve Housing
38. Piston
39. Spring
40. Washer
41. Retainer Ring
42. Pin
43. End Cap

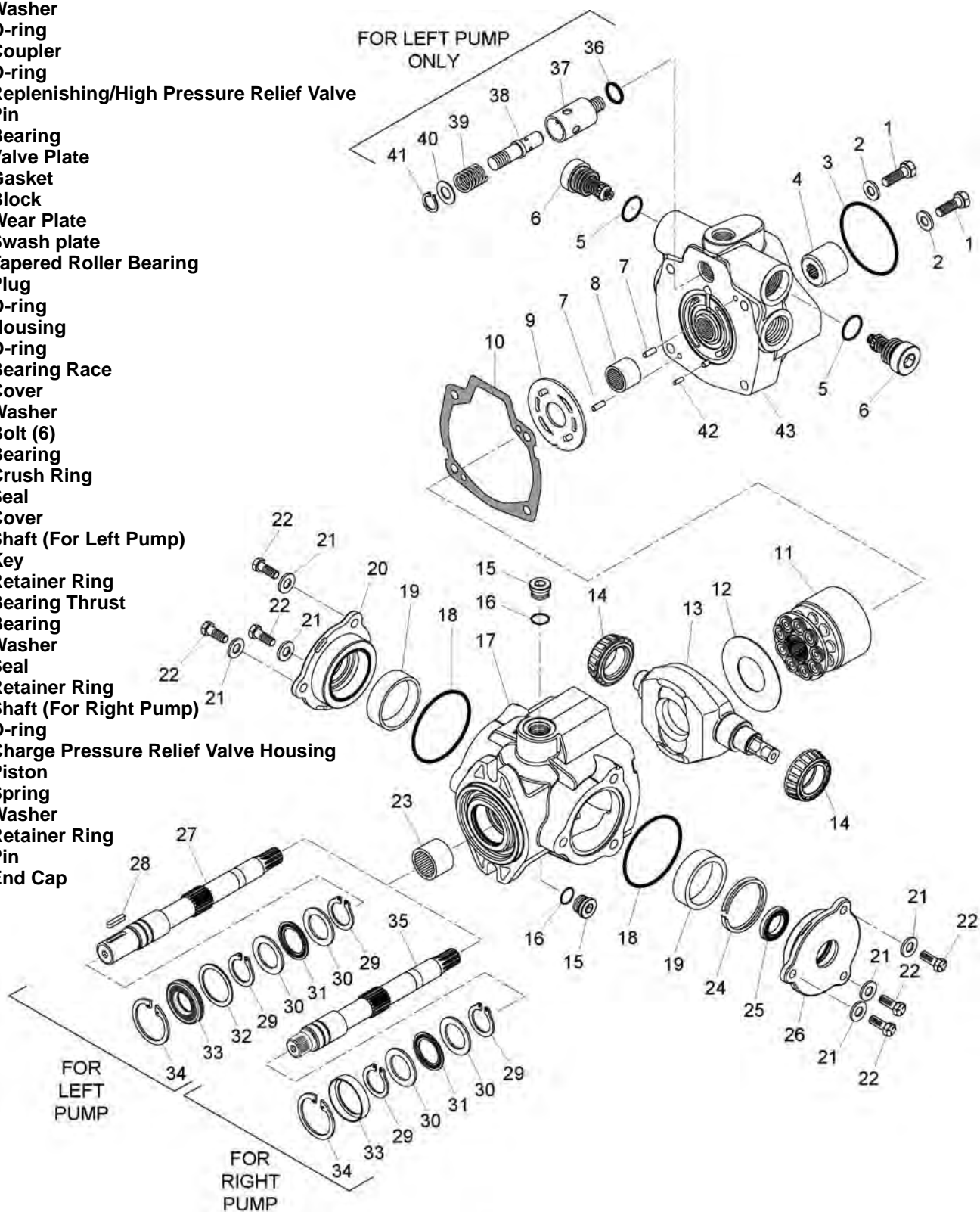

S4747

HYDROSTATIC PUMP (CONT'D)

Assembly (Cont'd)

Figure 30-40-45

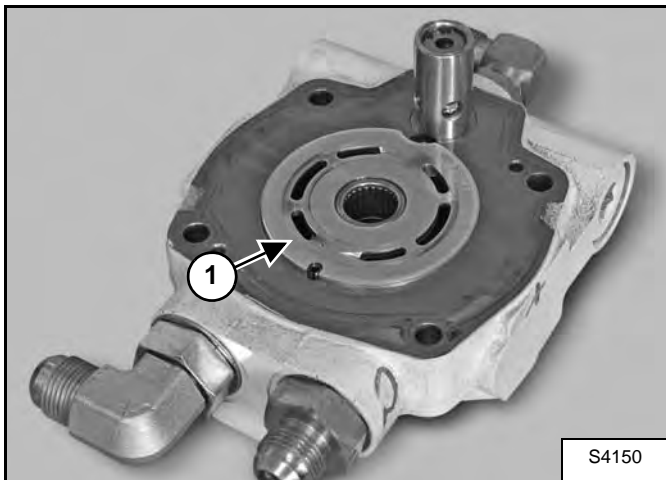

Coat the backside of the valve plate (Item 1) [Figure 30-40-45] with petroleum jelly to hold it in position and install the valve plate onto the end cap.

Figure 30-40-46

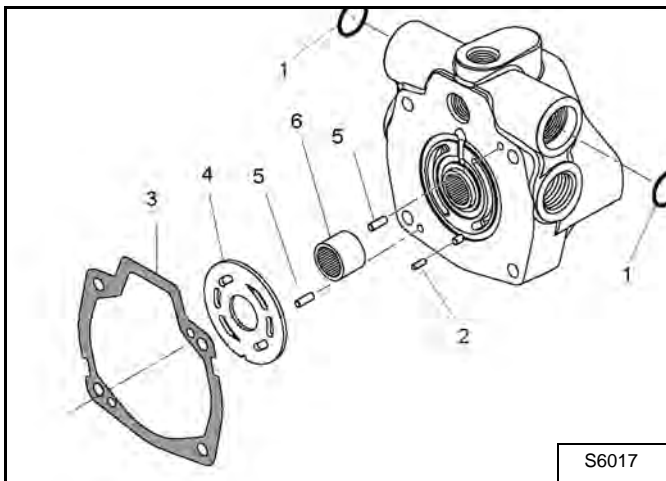

Install the two pins (Items 5) and gasket (Item 3) [Figure 30-40-46] onto the pump part.

Figure 30-40-47

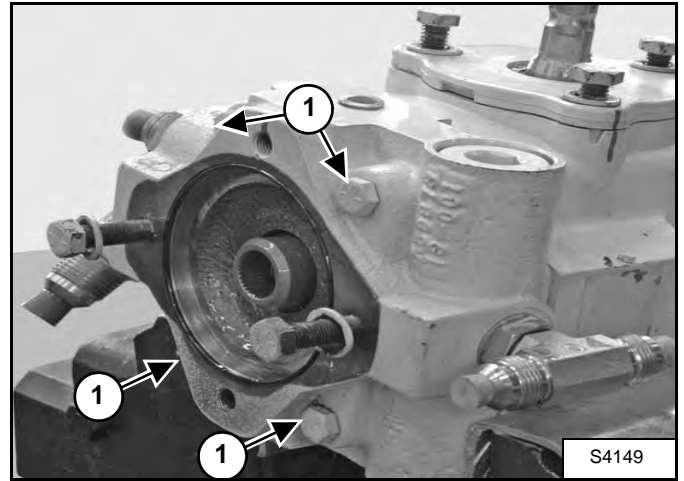

Assemble the two pump parts by means of the four bolts (Item 1) [Figure 30-40-47].

Tighten the bolts to 19 ft.-lb. (25 N•m) torque.

Hydrostatic Pump Start Up

Follow the hydraulic pump start up procedure (See Hydraulic Pump Start Up on Page 20-60-14).

DRIVE COMPONENTS

Description

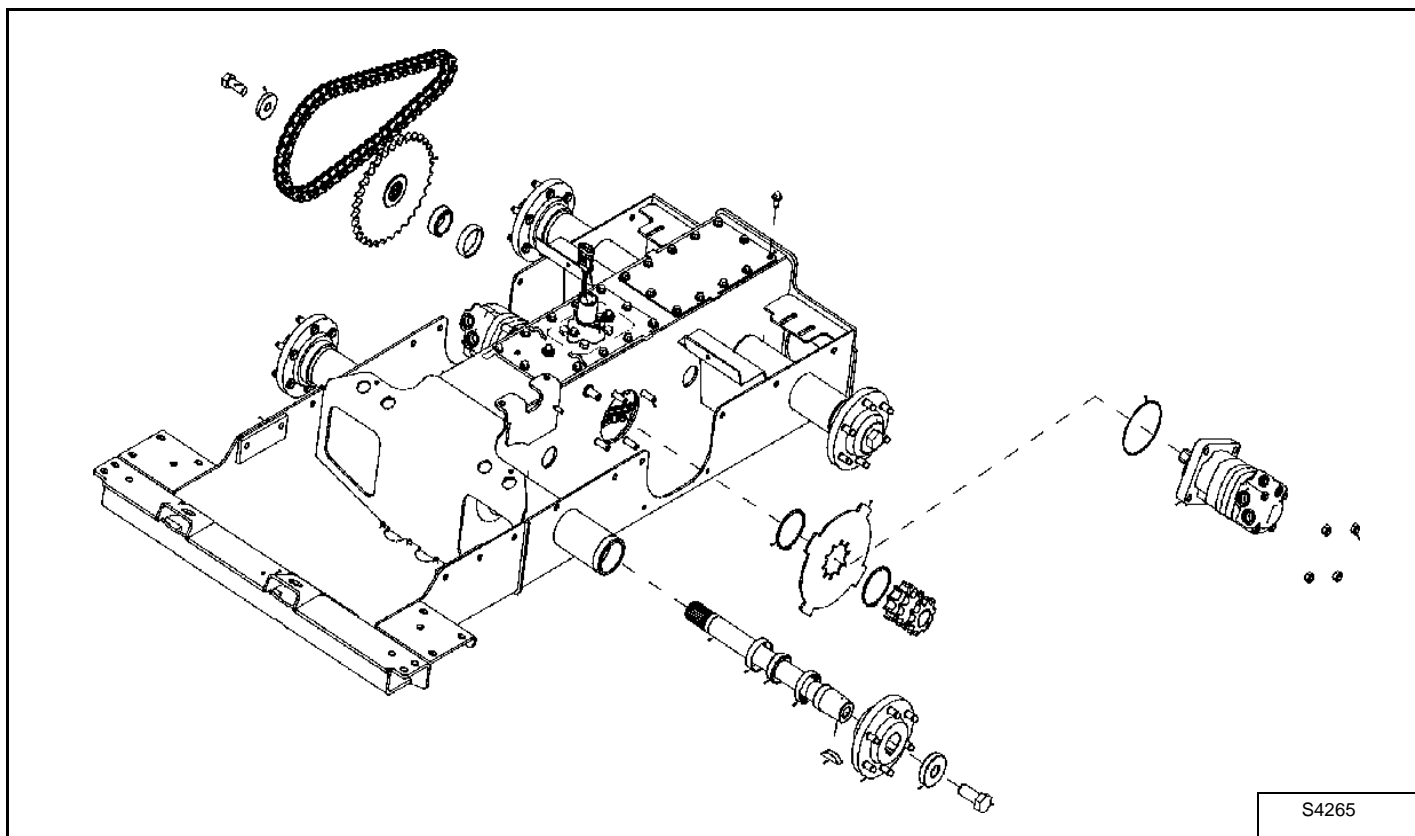

The drive components consist of a chaincase, drive chains, sprockets, axleshafts, hubs and a brake.

The chaincase is partially filled with hydraulic fluid to lubricate the chains and bearings.

On the bottom of the chaincase, there is a cover for access to the fuel tank drain plug.

CHAINCASE

Description

The chaincase contains the drive components.

Front Cover Removal And Installation

Raise the loader lift arms and install an approved lift arm support device (See LIFT ARM SUPPORT DEVICE on Page 10-20-1)

Raise the operator cab (See Raising on Page 10-30-1)



Never work on a machine with the lift arms up unless the lift arms are secured by an approved lift arm support device. Failure to use an approved lift arm support device can allow the lift arms or attachment to fall and cause injury or death.

W-2059-0598

Figure 40-30-1

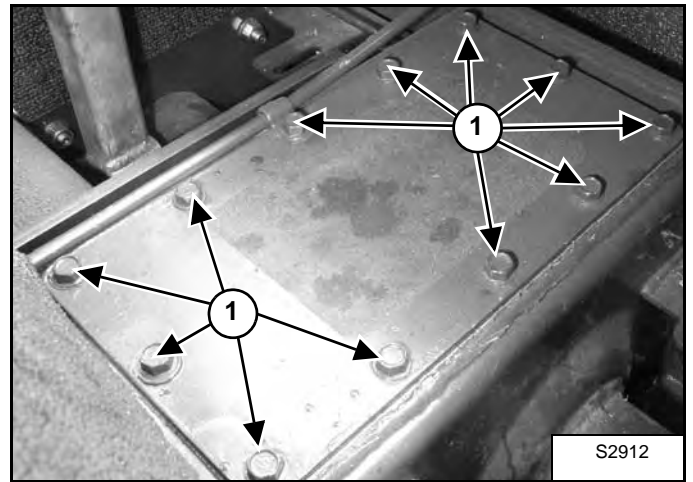

Remove the 12 front chaincase cover mounting screws (Item 1) [Figure 40-30-1].

Remove the front chaincase cover from the loader.

Installation: Apply polyurethane sealant to mating surfaces. Polyurethane sealant should be applied to the screw threads to stop oil leakage.

SEAT BAR (CONT'D)

Disassembly And Assembly

Figure 50-10-7

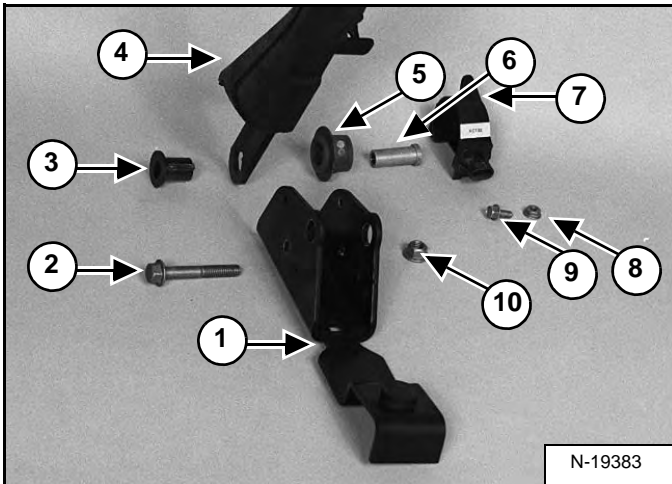
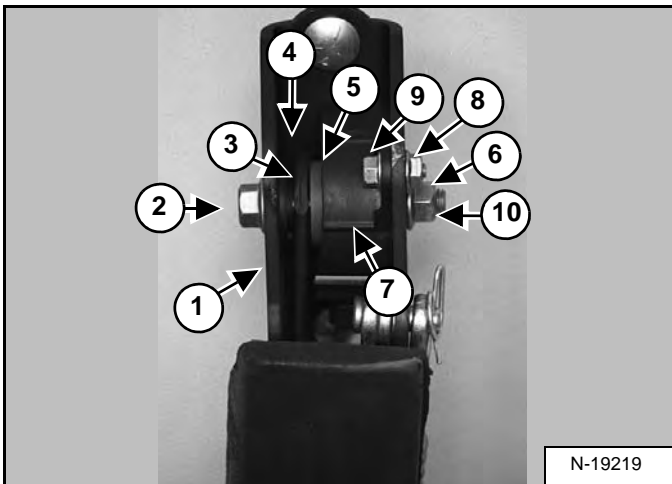

Figure 50-10-8



Assemble the parts as shown for the left side of the seat bar pivot assembly [Figure 50-10-7] and [Figure 50-10-8].

- Seat Bar Mount (Item 1)
- Mounting Bolt (Item 2)
- Keyed Plastic Bushing (Item 3)
- Seat Bar (Item 4)
- Magnetic Bushing Assembly (Item 5)
- Pivot Bushing (Item 6)
- Sensor Bracket (Item 7)
- Sensor Mounting Nut (Item 8)
- Sensor Mounting Bolt (Item 9)
- Mounting Nut (Item 10)

Installation: Tighten the mounting bolt (Item 2) [Figure 50-10-7] and [Figure 50-10-8] to 50-70 in.-lb. (5,6-7,9 N•m) torque.

Figure 50-10-9

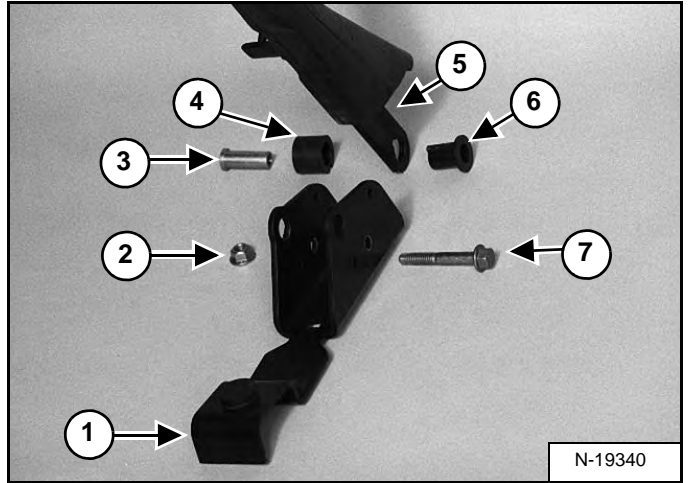
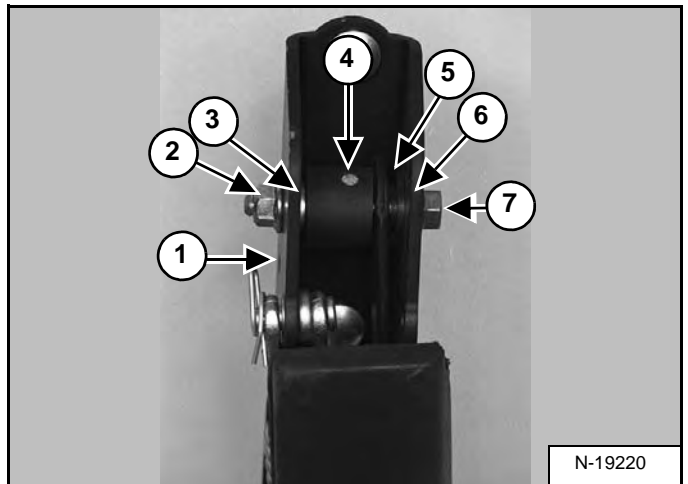

Figure 50-10-10



Assemble the parts as shown for the right side of the seat bar pivot assembly [Figure 50-10-9] and [Figure 50-10-10].

- Seat Bar Mount (Item 1)
- Mounting Nut (Item 2)
- Pivot Bushing (Item 3)
- Spacer Bushing (Item 4)
- Seat Bar (Item 5)
- Keyed Plastic Bushing (Item 6)
- Mounting Bolt (Item 7)

Installation: Tighten the mounting bolt (Item 7) [Figure 50-10-9] and [Figure 50-10-10] to 50-70 in.-lb. (5,6-7,9 N•m) torque.

OPERATOR SEAT (SUSPENSION)

Removal And Installation

Figure 50-31-1

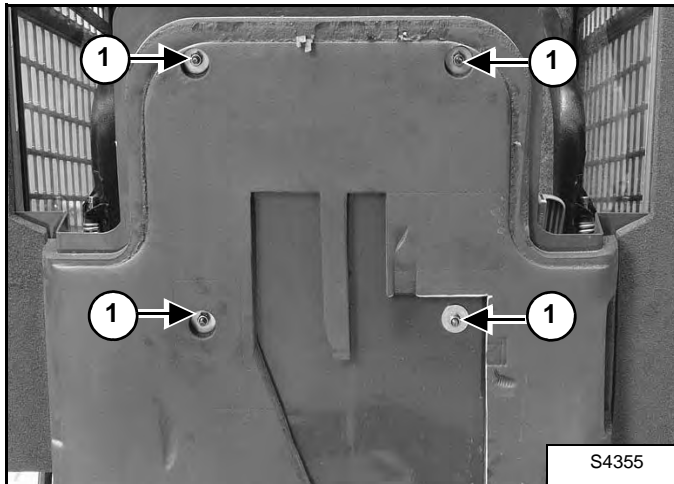

Raise the operator cab. (See Raising on Page 10-30-1.)

Remove the four seat mounting nuts (Item 1) [Figure 50-31-1] and washers from the operator seat mounting studs.

Installation: Tighten the mounting nuts to 20 ft.-lb. (27 N•m) torque.

Figure 50-31-2

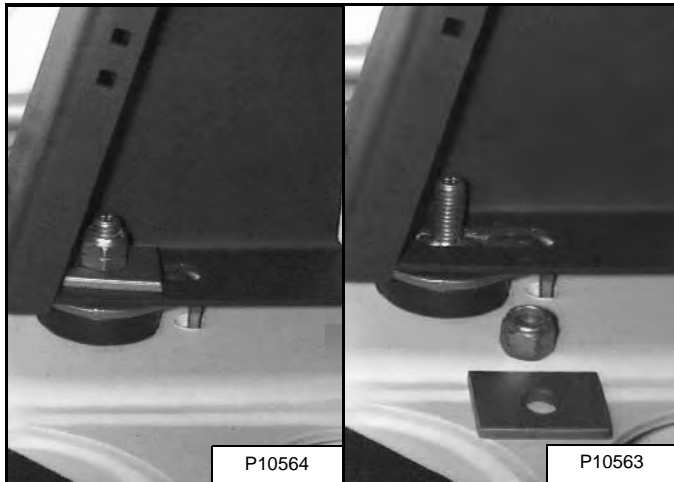

Lower the cab and install one of the mounting washers and a nut [Figure 50-31-2].

NOTE: With the seat removed, the cab will raise.

Reverse the removal procedure to install the operator seat.

Figure 50-31-3

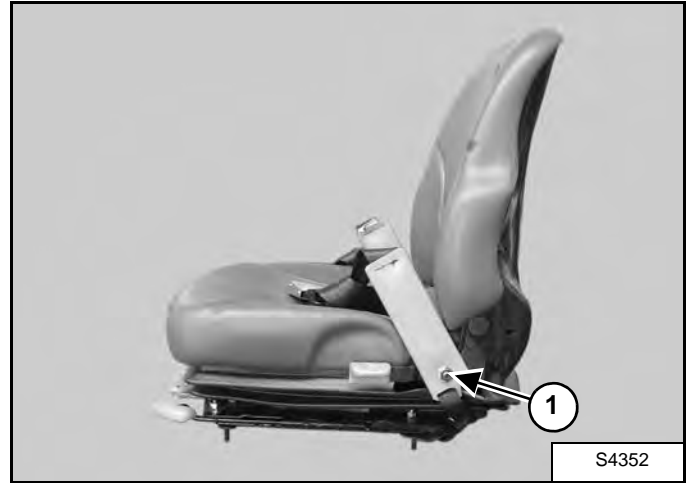
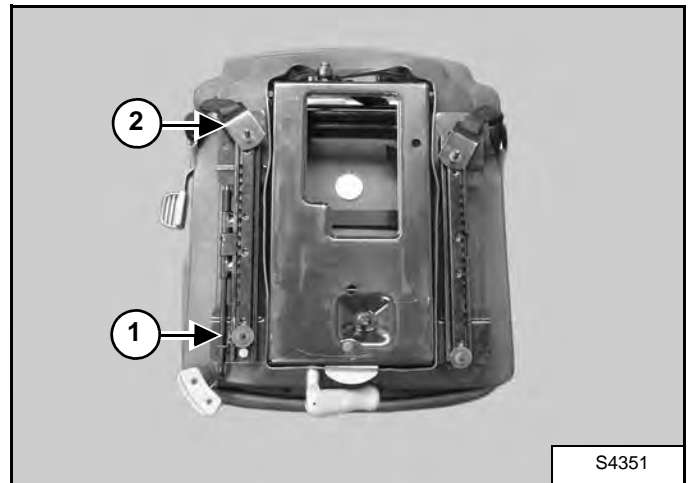

Figure 50-31-4



NOTE: Assure seat tethers are securely fastened to the seatbelt studs (Item 1) [Figure 50-31-3] and the seat rail studs (Item 2) [Figure 50-31-4].

NOTE: Verify the front two seat rail studs have washers attached (Item 1) [Figure 50-31-4].

CLICK HERE TO **DOWNLOAD** THE COMPLETE MANUAL

- Thank you very much for reading the preview of the manual.
- You can download the complete manual from: www.heydownloads.com by clicking the link below



- Please note: If there is no response to CLICKING the link, please download this PDF first and then click on it.

CLICK HERE TO **DOWNLOAD** THE COMPLETE MANUAL

BOB-TACH (POWER OPTION)

Description

The Bob-tach is the section of the loader lift arm that attachments mount to. The Power Bob-tach option uses two hydraulically operated, spring assisted, locking wedge and lever assemblies to secure the attachment to the Bob-tach.

The hydraulically operated Power Bob-tach has a hydraulic cylinder that opens and closes both wedge and lever assemblies by pressing a switch on the front accessory panel. The switch activates the Power Bob-tach block to allow flow into or out of the hydraulic cylinder connected to the levers on the Bob-tach.

The Power Bob-tach block is located under the cab, on the front left side, below the Bucket Positioning Valve (if equipped).

The Bob-tach is located on the front of the loader connected to the loader lift arms.

Removal And Installation

Figure 50-41-1

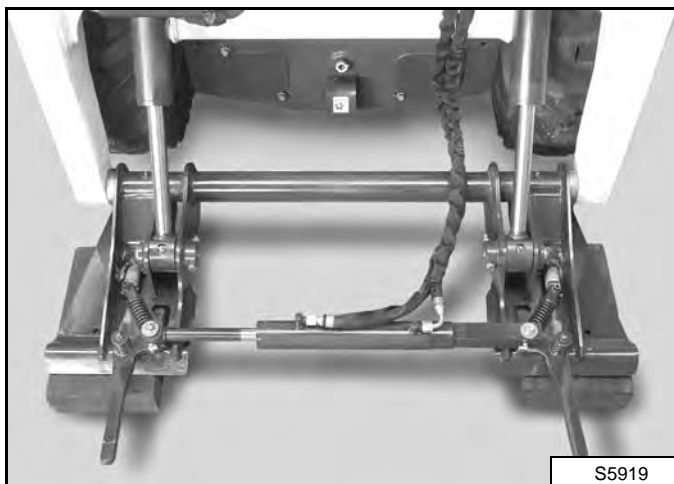

Tilt the Bob-Tach forward, so it is parallel to the floor. Put blocks (approximately 3 inches) under each side of the Bob-Tach [Figure 50-41-1].

Lower the Bob-Tach onto the blocks.

Remove the hoses on the cylinder fittings (Item 1) [Figure 50-41-1].

Remove the hose clamp on the hoses and use the bolt (Item 2) [Figure 50-41-1] on the Bob-Tach lever to secure the clamp.

Figure 50-41-2

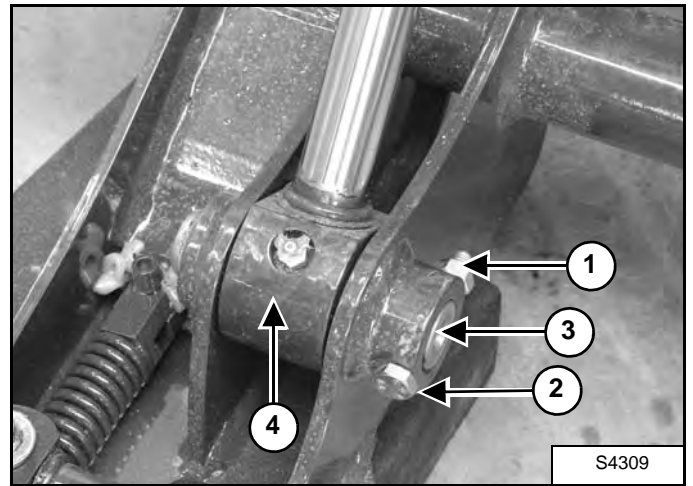

Remove the retainer bolt (Item 1) and nut (Item 2) [Figure 50-41-2] from the tilt cylinder rod end pin.

Installation: Tighten the retainer bolt and nut to 25-28 ft.-lb. (34-38 N•m) torque.

Remove the pivot pin (Item 3) [Figure 50-41-2] from the tilt cylinder rod end.

Remove the tilt cylinder rod end (Item 4) [Figure 50-41-2] from the Bob-Tach.

REAR GRILL

Removal And Installation

Figure 50-60-1

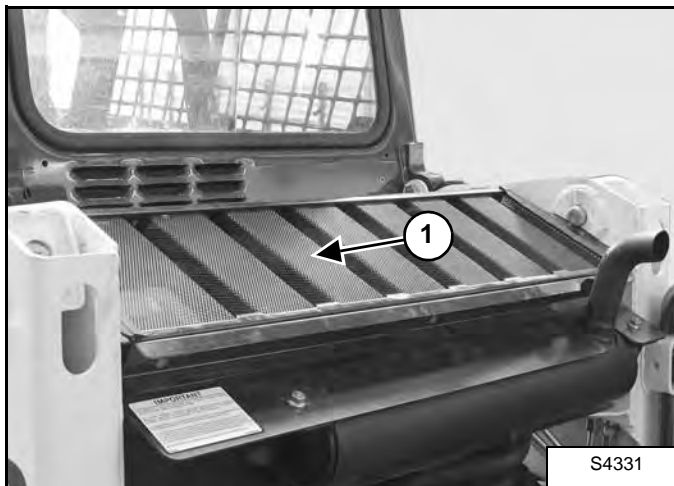

Open the rear door.

Figure 50-60-2

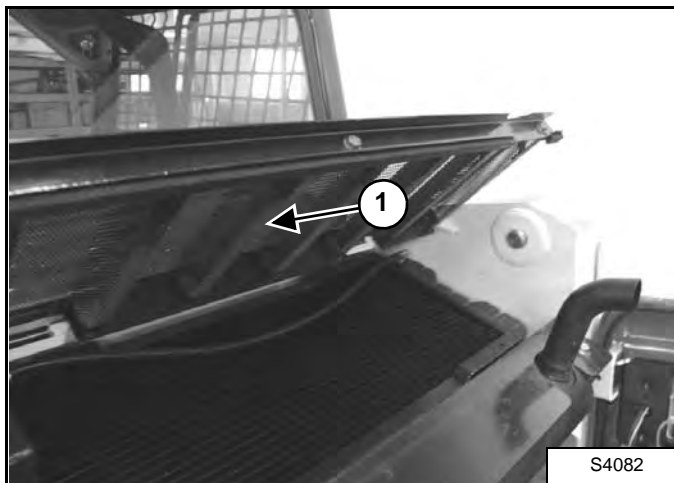

Lift up on the rear grill (Item 1) [Figure 50-60-1] and [Figure 50-60-2].

Lift the grill away from the loader.

Figure 50-60-3

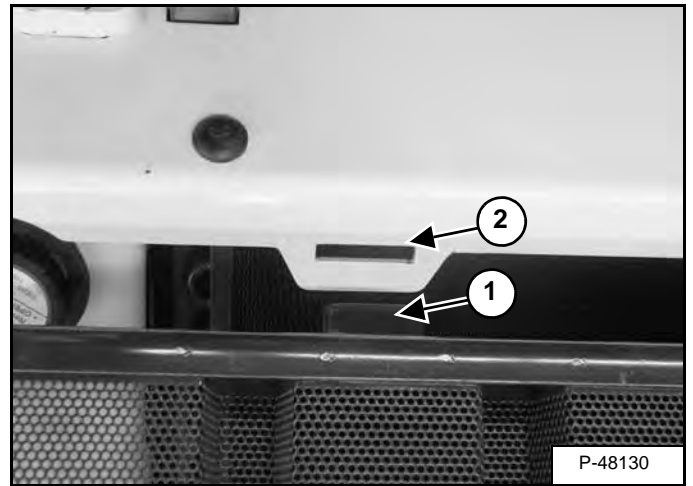

Installation: Line up the tab (Item 1) on the grill with the slot (Item 2) [Figure 50-60-3] on the loader mainframe. Insert the tab fully and then push down.

Reverse the removal procedure to install the grill.

CONTROL PEDALS AND LINKAGES

Description

The control pedals and linkages are connected to the control valve. The control pedals will mechanically move the lift and tilt spools on the control valve.

The control pedals and linkages are located on the lower mainframe at the operator's feet.

Pedal Removal And Installation

WARNING

Never work on a machine with the lift arms up unless the lift arms are secured by an approved lift arm support device. Failure to use an approved lift arm support device can allow the lift arms or attachment to fall and cause injury or death.

W-2059-0598

Raise the lift arms and install an approved lift arm support device (See LIFT ARM SUPPORT DEVICE on Page 10-20-1.)

Raise the operator cab (See Raising on Page 10-30-1.)

	<h2>DANGER</h2>	
<h3>AVOID DEATH</h3>		
<ul style="list-style-type: none">• Disconnecting or loosening any hydraulic tubeline, hose, fitting, component or a part failure can cause lift arms to drop.• Keep out of this area when lift arms are raised unless supported by an approved lift arm support. Replace if damaged.		
<small>67116 SW 6717341A enUS</small>		

Figure 50-90-1

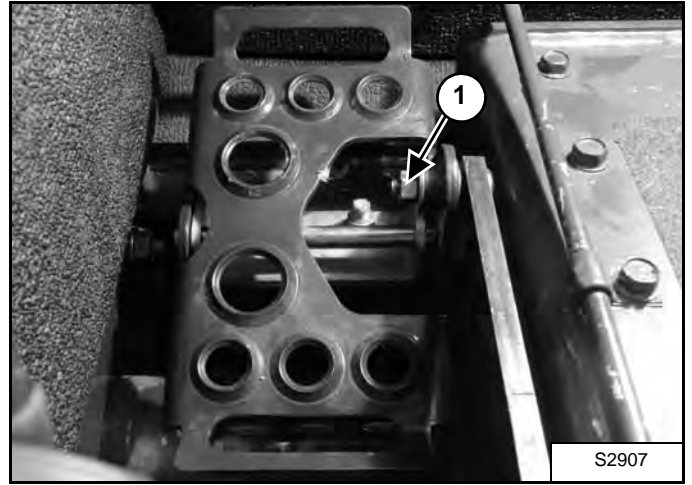

Remove the bolt (Item 1) [Figure 50-90-1] and nut from the pedal linkage.

Installation: Tighten the bolt and nut to 25-28 ft.-lb. (34-38 N•m) torque.

Check the rubber bushing in the pedal for wear and replace as needed.

Figure 50-90-2

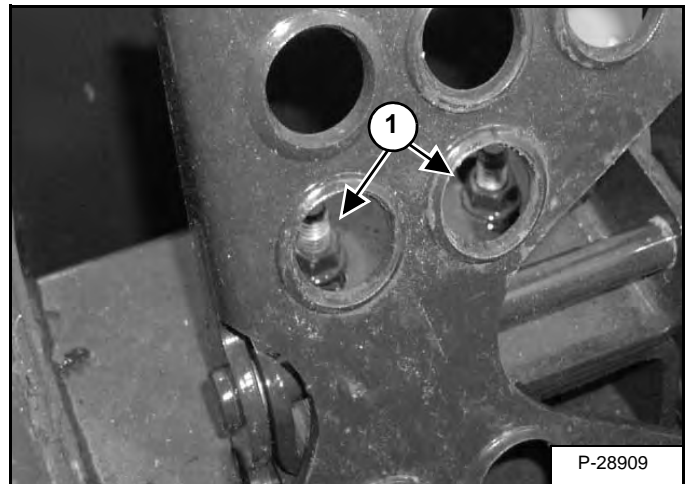

Remove the two mounting bolts (Item 1) [Figure 50-90-2] from the pedal mounting bracket.

Remove the pedal assembly from the loader.

CONTROL PANEL (CONT'D)

Pintle Arm Removal And Installation (Cont'd)

Figure 50-100-21

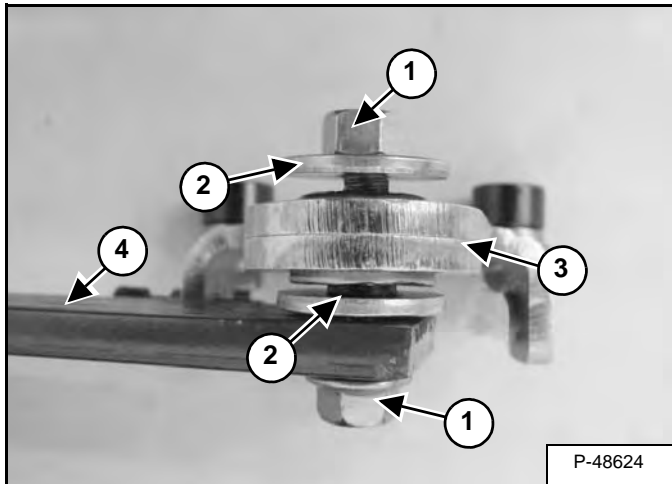

Remove the bolt and nut (Item 1) [Figure 50-100-21].

Inspect the washers (Item 2), pintle arm (Item 3) and the steering linkage bar (Item 4) [Figure 50-100-21] for damage and replace as needed.

NOTE: The washers (Item 2) [Figure 50-100-21] are hardened, and should only be replaced through Bobcat Parts.

Figure 50-100-22

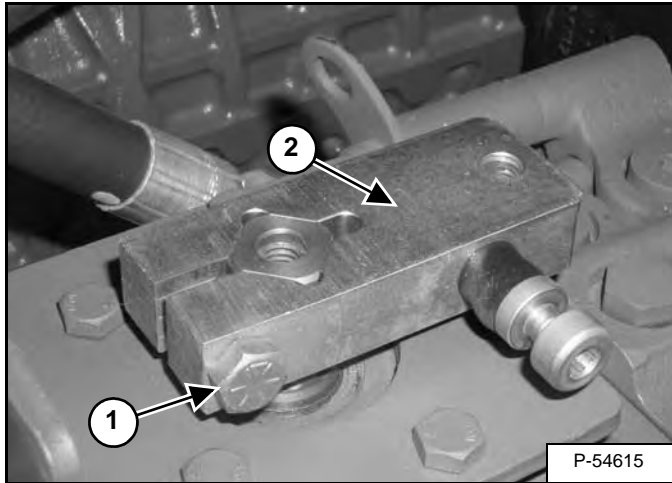

Loosen the bolt (Item 1) and remove the pintle base (Item 2) [Figure 50-100-22].

Figure 50-100-23

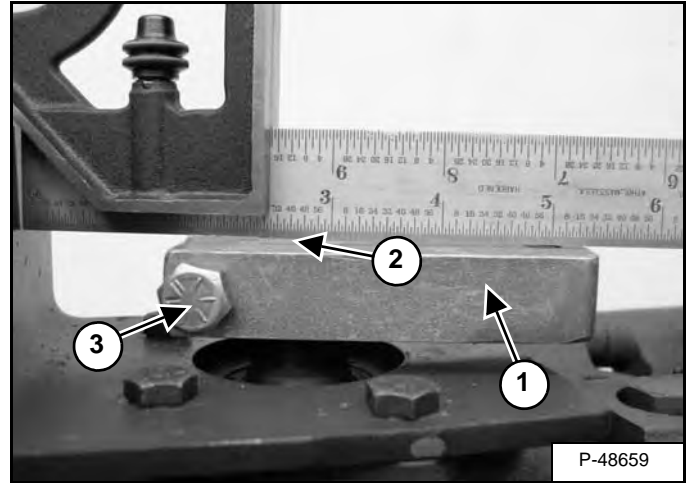

NOTE: When installing the pintle base (Item 1) onto the pump shaft, the cutouts on the pump shaft will not line up with the bolt (Item 3) [Figure 50-100-23].

Installation: Install the pintle base (Item 1) onto the pump shaft (Item 2) [Figure 50-100-23]. The top of the pintle base should be level with the top of the pump shaft. Tighten the bolt to 35-40 ft.-lb. (47,5-54,2 N•m) torque.

NOTE: After installing the linkage onto the hydrostatic pumps the linkage neutral adjustment procedure must be performed.

Figure 50-100-24

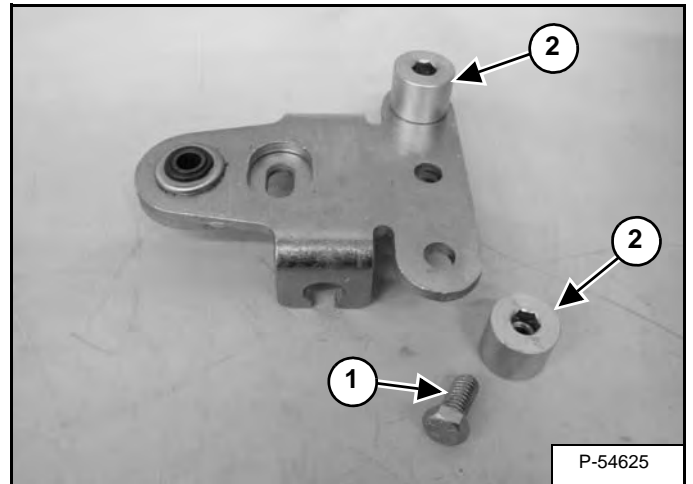

Remove the bolt (Item 1) from the pintle solid cams (Item 2) [Figure 50-100-24] and inspect the pintle solid cams for damage or excessive wear.

Installation: Tighten the bolts to 35-40 ft.-lb. (47,5-54,2 N•m) torque.

CONTROL HANDLE / LEVER

Description

The control handles / levers are used to control the forward and reverse travel.

The control handles / levers are mounted onto the control panel.

Lever Removal And Installation

Figure 50-110-1

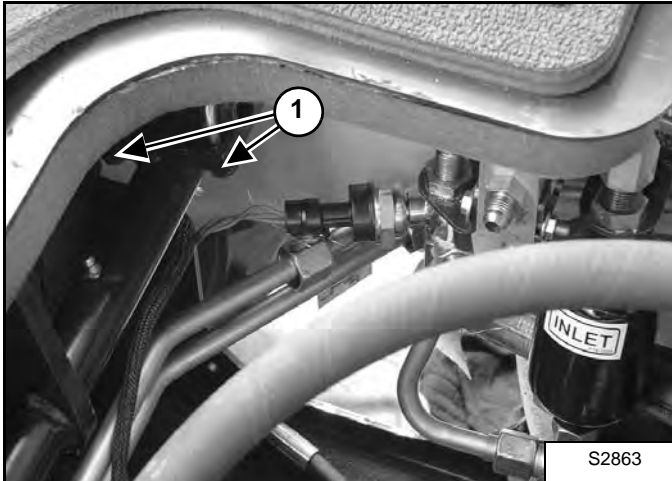

Remove the nuts from the two U-bolts (Item 1) [Figure 50-110-1] used to mount the control lever.

Remove the U-bolts from the control lever mount.

Remove the control lever (Item 2) [Figure 50-110-1] by sliding the lever through the rubber boot (Item 1) [Figure 50-110-2] on the front of the control panel.

Installation: Tighten the U-bolts so the lever can not be moved right or left when seated in the operator seat. Be sure the control lever does not interfere with the operator cab when lowering or raising the cab.

Boot Removal And Installation

Figure 50-110-2

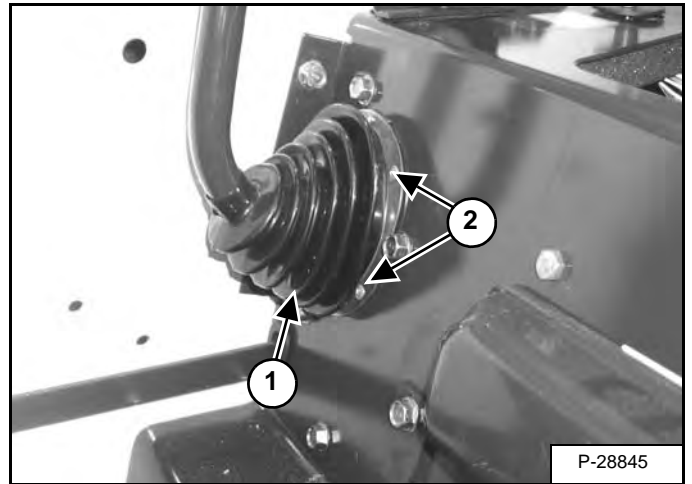

To replace the rubber boot (Item 1) [Figure 50-110-2] on the control panel, remove the control lever (See Lever Removal And Installation on Page 50-110-1)

Drill out the four rivets (Item 2) [Figure 50-110-2] located on the flange of the rubber boot and remove the old boot.

Install the new boot and reinstall the control lever.

WINDOW (FRONT DOOR) (CONT'D)

Installation (Standard Window) (Cont'd)

Figure 50-123-8

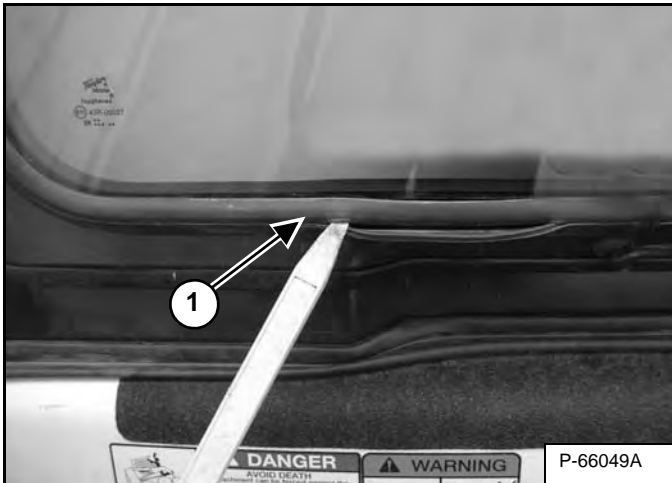

Use the plastic stick (Item 1) [Figure 50-123-8] to position the locking tab into the groove to secure the window in the molding.

Tapping the window corners will help seat the window in the molding.

Figure 50-123-9

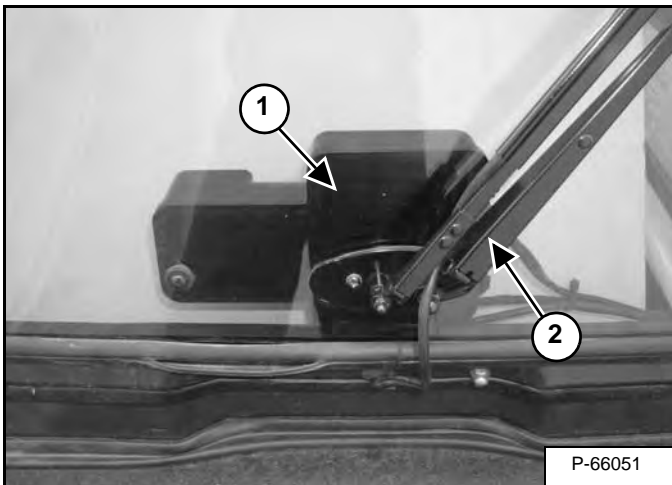

Install the wiper motor (Item 1) and wiper arm assembly (Item 2) [Figure 50-123-9].

Removal And Installation (Special Applications Window)

Replace the Lexan glazing under the following conditions:

- When the glazing is four years old;
- When the glazing becomes yellow or hazed;
- Is scratched on either side with scratches that can be felt with the fingernail;
- Has cracks coming from the edges or mounting holes, or fine cracks on the surface area;
- Has contacted any fluids that have caused cloudiness.

Figure 50-123-10

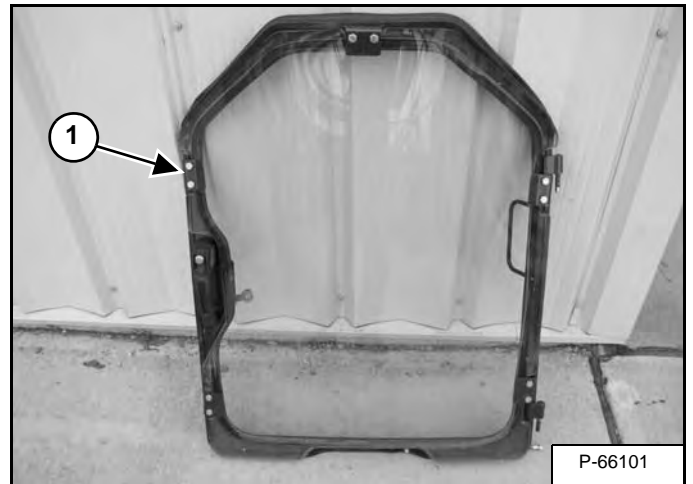

Remove window from loader.

NOTE: The Special Applications window is held on by the brackets only, it does not sit in the rubber molding. During Removal the window may fall as the mounting bolts are loosened.

Remove the five mounting brackets and bolts (Item 1) [Figure 50-123-10].

ELECTRICAL SCHEMATIC
S100 (S/N A2G811001 AND ABOVE)
(S/N A8ET11001 - A8ET19999)
 (printed JANUARY 2009)
 7136959

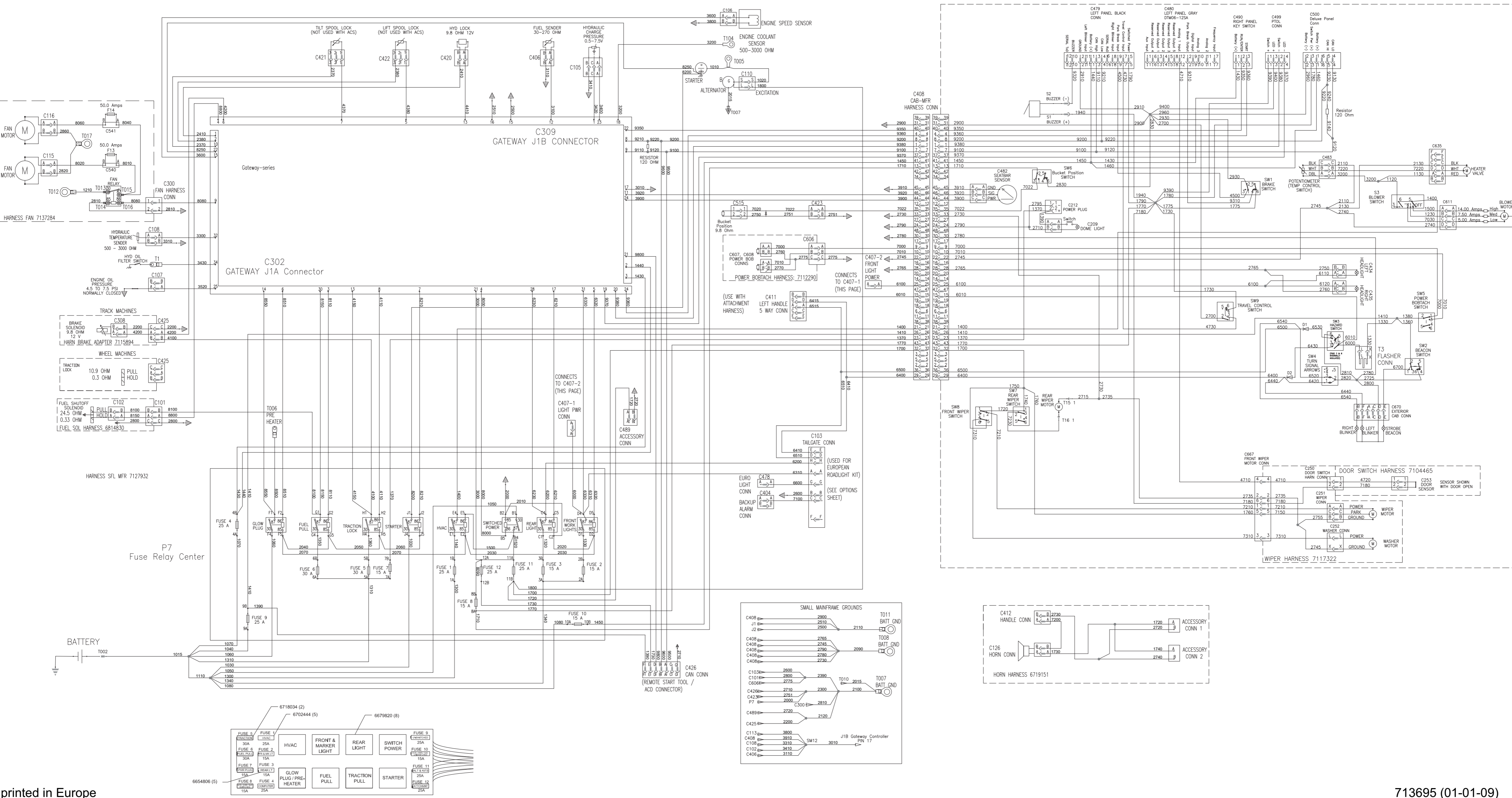



Bobcat®

ALTERNATOR (CONT'D)

Parts Identification

- | | |
|---------------|---------------|
| 1. Alternator | 11. Bearing |
| 2. Nut | 12. Stator |
| 3. Pulley | 13. Housing |
| 4. Spacer | 14. Sleeve |
| 5. Bolt | 15. Regulator |
| 6. Housing | 16. Rectifier |
| 7. Bolt | 17. Cover |
| 8. Bearing | 18. Spacer |
| 9. Retainer | 19. Nut |
| 10. Rotor | |

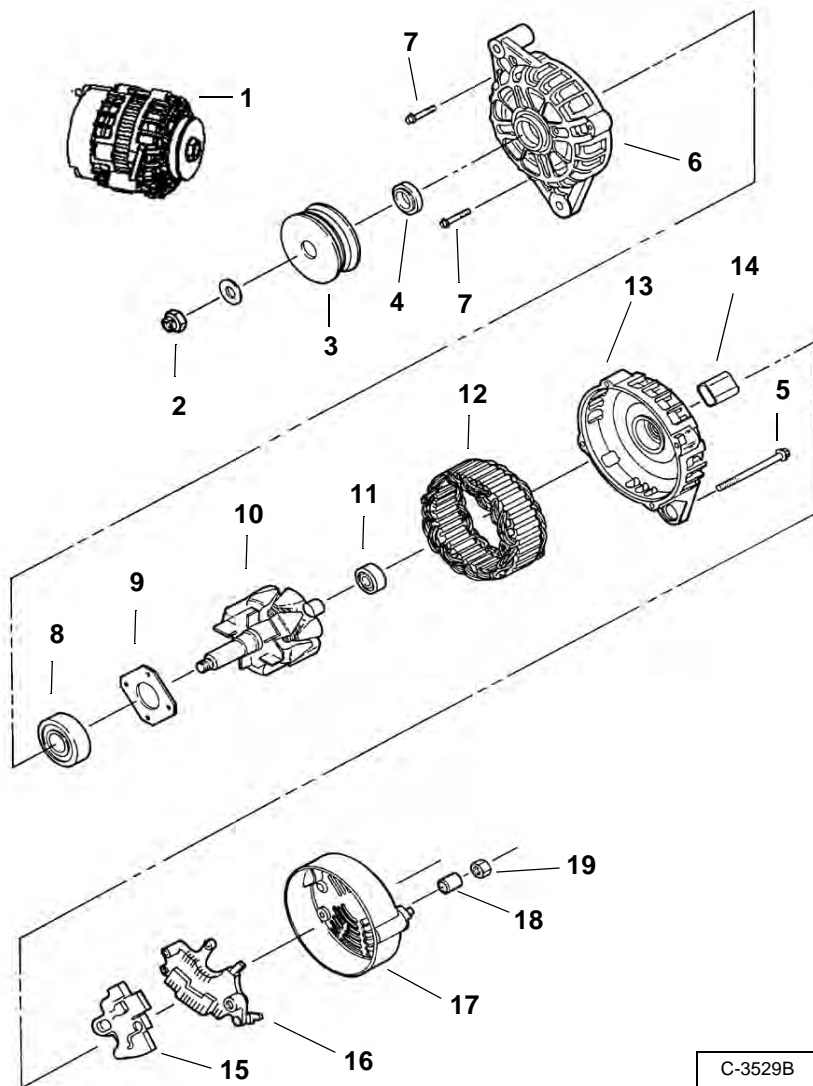

C-3529B

INSTRUMENT PANELS (CONT'D)

Removal And Installation (Left And Right)

Figure 60-50-8

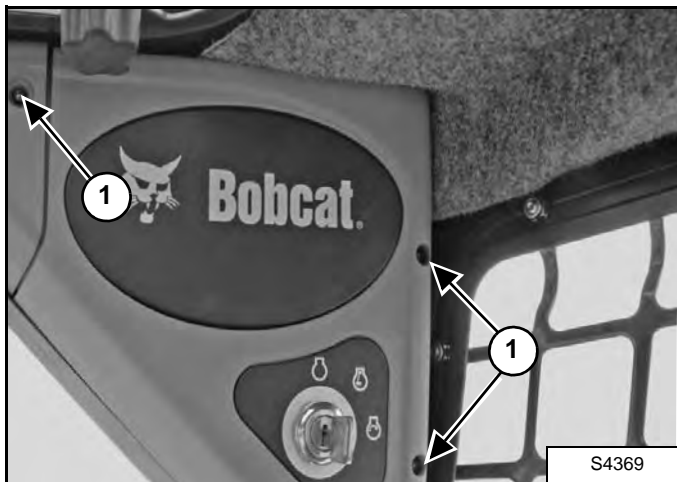

Remove the three mounting bolts (Item 1) [Figure 60-50-8].

Installation: Be careful to not overtighten the instrument panel mounting bolts to prevent stripping of the threaded holes in the panels.

Figure 60-50-9

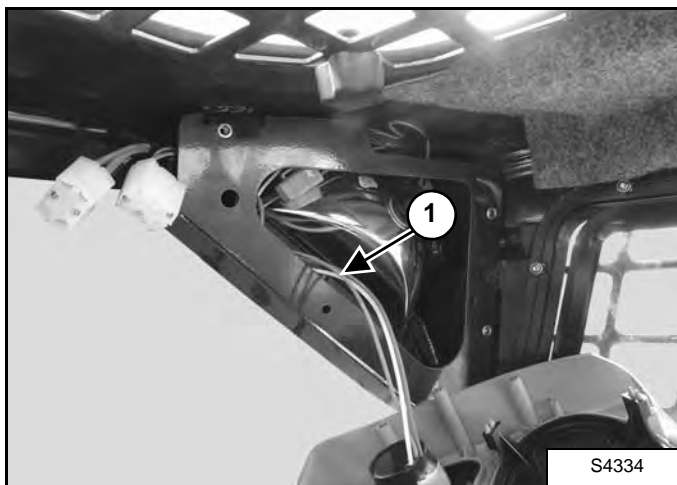

Pull the right instrument panel down and disconnect the key switch wiring harness connector (Item 1) [Figure 60-50-9] from the panel.

Remove the panel from the loader cab.

Figure 60-50-10



Remove the three mounting bolts (Item 1) [Figure 60-50-10].

Installation: Be careful to not overtighten the instrument panel mounting bolts to prevent stripping of the threaded holes in the panels.

Figure 60-50-11

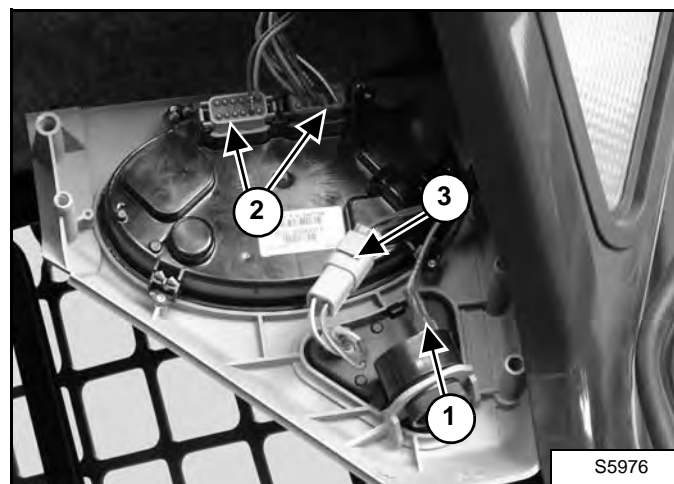

Pull the left instrument panel down and disconnect the two connectors (Item 1) [Figure 60-50-11] from the loader alarm.

Disconnect the two wire harness connectors (Item 2) [Figure 60-50-11] from the loader instrument panel.

Disconnect the connector (Item 3) [Figure 60-50-11] from the loader instrument panel.

Remove the instrument panel from the loader.

DIAGNOSTIC SERVICE CODES (CONT'D)

Service Codes List

CODE	DESCRIPTION	CODE	DESCRIPTION
A3623	ACD not programmed	D3907	Left joystick Y-axis not in neutral
A8002	ACD output 'A' error ON	D4007	Right joystick Y-axis not in neutral
A8003	ACD output 'A' error OFF	D7501	CAN joystick communication error
A8005	ACD output 'A' short to battery	D7509	Operating mode switch short to ground or battery
A8006	ACD output 'A' short to ground	D7513	Right front wheel angle sensor unresponsive
A8007	ACD output 'A' open circuit	D7514	Left front wheel angle sensor unresponsive
A8032	ACD output 'A' overcurrent	D7515	Right rear wheel angle sensor unresponsive
A8102	ACD output 'B' error ON	D7516	Left rear wheel angle sensor unresponsive
A8103	ACD output 'B' error OFF	D7517	Left swash plate not in neutral
A8105	ACD output 'B' short to battery	D7518	Right swash plate not in neutral
A8106	ACD output 'B' short to ground	D7523	Right front wheel angle sensor out of range high
A8107	ACD output 'B' open circuit	D7524	Left front wheel angle sensor out of range high
A8132	ACD output 'B' overcurrent	D7525	Right rear wheel angle sensor out of range high
A8202	ACD output 'C' error ON	D7526	Left rear wheel angle sensor out of range high
A8203	ACD output 'C' error OFF	D7527	Left swash plate out of position
A8205	ACD output 'C' short to battery	D7528	Right swash plate out of position
A8206	ACD output 'C' short to ground	D7533	Right front wheel angle sensor out of range low
A8207	ACD output 'C' open circuit	D7534	Left front wheel angle sensor out of range low
A8232	ACD output 'C' overcurrent	D7535	Right rear wheel angle sensor out of range low
A8302	ACD output 'D' error ON	D7536	Left rear wheel angle sensor out of range low
A8303	ACD output 'D' error OFF	D7537	Sensor supply 1 out of range low
A8305	ACD output 'D' short to battery	D7538	Sensor supply 2 out of range low
A8306	ACD output 'D' short to ground	D7539	Left swash plate sensor out of range high
A8307	ACD output 'D' open circuit	D7540	Left swash plate sensor out of range low
A8332	ACD output 'D' overcurrent	D7541	Right swash plate sensor out of range high
A8402	ACD output 'E' error ON	D7542	Right swash plate sensor out of range low
A8403	ACD output 'E' error OFF	D7543	Left forward drive short to battery
A8405	ACD output 'E' short to battery	D7544	Left reverse drive short to battery
A8406	ACD output 'E' short to ground	D7545	Right forward drive short to battery
A8407	ACD output 'E' open circuit	D7546	Right reverse drive short to battery
A8432	ACD output 'E' overcurrent	D7547	Right front steer extend short to battery
A8502	ACD output 'F' error ON	D7548	Left front steer extend short to battery
A8503	ACD output 'F' error OFF	D7549	Right rear steer extend short to battery
A8505	ACD output 'F' short to battery	D7550	Left rear steer extend short to battery
A8506	ACD output 'F' short to ground	D7551	Steer pressure short to battery
A8507	ACD output 'F' open circuit	D7552	Back-up alarm error ON
A8532	ACD output 'F' overcurrent	D7553	Left forward drive short to ground
A8602	ACD output 'G' error ON	D7554	Left reverse drive short to ground
A8603	ACD output 'G' error OFF	D7555	Right forward drive short to ground
A8605	ACD output 'G' short to battery	D7556	Right reverse drive short to ground
A8606	ACD output 'G' short to ground	D7557	Right front steer extend short to ground
A8607	ACD output 'G' open circuit	D7558	Right front steer retract short to ground
A8702	ACD output 'H' error ON	D7559	Left front steer extend short to ground
A8703	ACD output 'H' error OFF	D7560	Left front steer retract short to ground
A8705	ACD output 'H' short to battery	D7561	Right rear steer extend short to ground
A8706	ACD output 'H' short to ground	D7562	Right rear steer retract short to ground
A8707	ACD output 'H' open circuit	D7563	Left rear steer extend short to ground
		D7564	Left rear steer retract short to ground
D3905	Left joystick X-axis not in neutral	D7565	Steer pressure short to ground

SEAT BAR SENSOR (CONT'D)

Testing

Figure 60-100-1

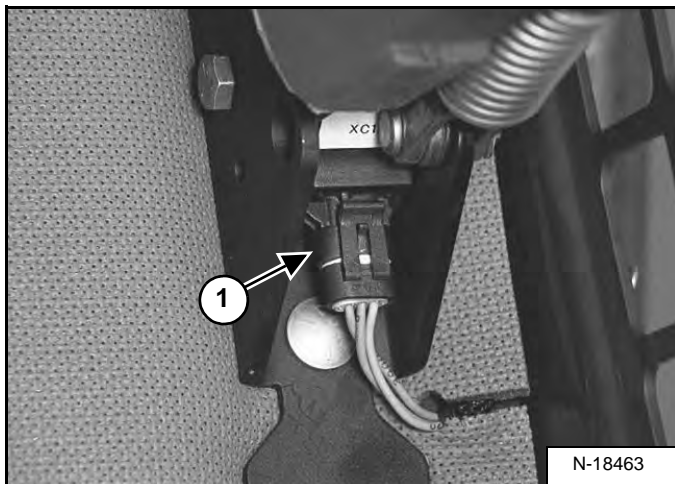

Use a Sensor Tester (MEL1428) and seat bar sensor tester adapter (MEL1567) for the following procedure:

Connect the seat bar adapter sensor leads to the sensor tester.

Disconnect the seat bar sensor connector (Item 1) [Figure 60-100-1].

Figure 60-100-2

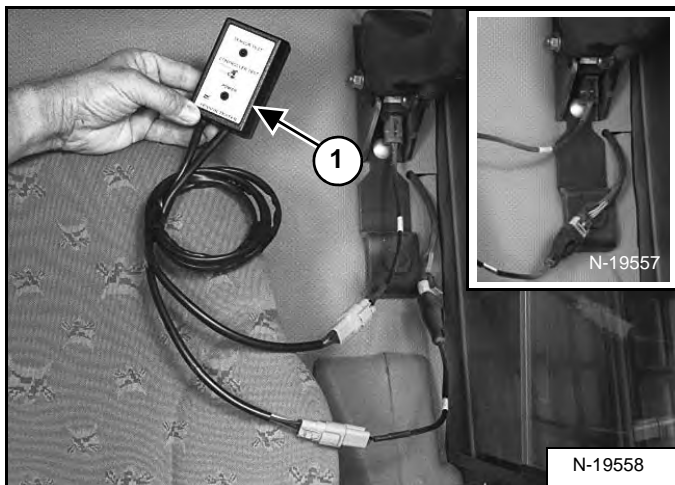

Connect the Sensor Tester (Item 1) [Figure 60-100-2] inline to the seat bar sensor connectors. (See inset).

Turn the key to the ON position. **DO NOT START THE ENGINE.**

The toggle switch (Item 2) [Figure 60-100-3] can be in either the **Absent** or **Present** position.

Figure 60-100-3

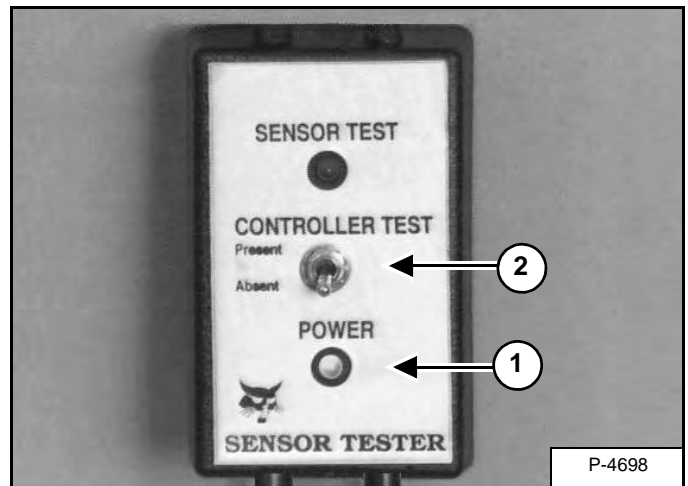

If there is no power light (Item 1) [Figure 60-100-3] on the sensor tester, check the tester or wiring harness.

Figure 60-100-4

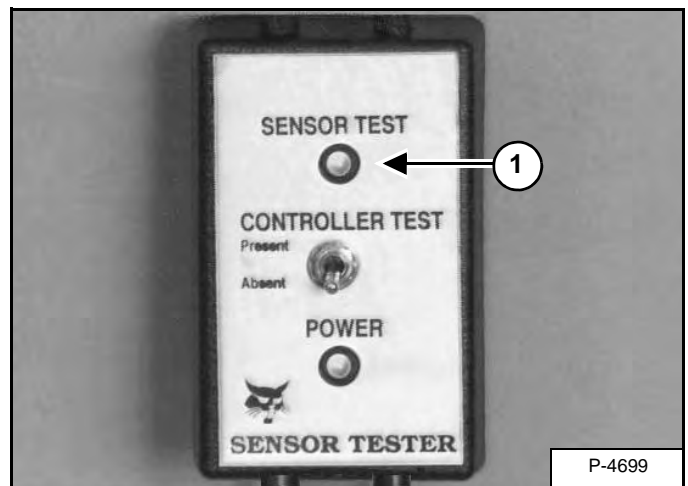

Lower the seat bar. The Sensor Test light (Item 1) [Figure 60-100-4] should illuminate.

Raise the seat bar. The Sensor Test light (Item 1) [Figure 60-100-4] should go off.

If the above test fails, there is a problem with the seat bar sensor.

Disconnect the Sensor Tester.

Replace the Seat Bar Sensor. (See Removal And Installation on Page 60-100-3.)

If the above test passes, run the seat bar sensor BICS circuit test.



Bobcat®

MAINTENANCE CLOCK (CONT'D)

Setup

Figure 60-160-3

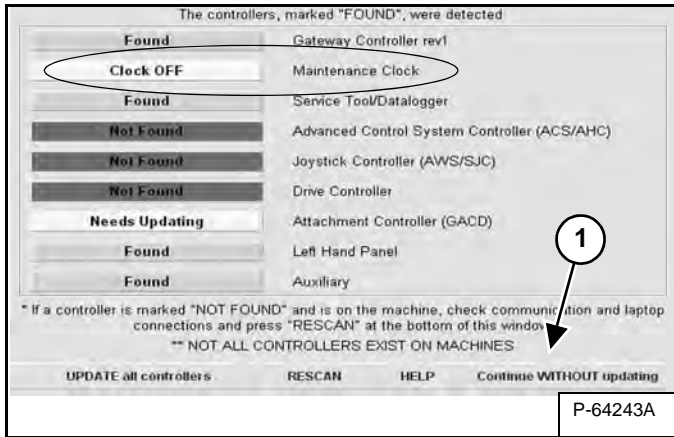

The first analyzer screen has an added bar for the Maintenance Clock. The clock will remain OFF until activated. Click **Continue** (Item 1) [Figure 60-160-3] to view the next analyzer screen.

Figure 60-160-4

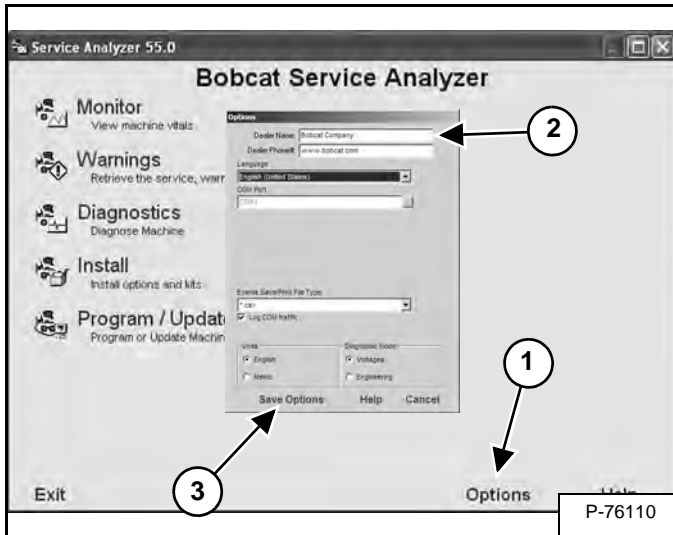

Click **Options** (Item 1) and add your dealer name and phone number (Item 2). Click **Save Options** (Item 3) [Figure 60-160-4] the information is now stored. This will be displayed on Deluxe Instrumentation Panel equipped loaders when the maintenance clock is less than 10 hours until next planned maintenance.

Figure 60-160-5

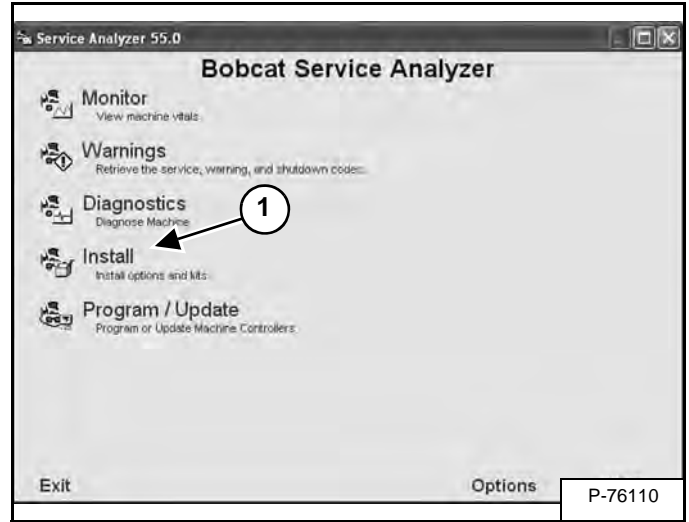

Select **Install** (Item 1) [Figure 60-160-5] to begin sending the dealer information to the controller.

Figure 60-160-6



Click **SEND TO MACHINE** (Item 1) [Figure 60-160-6] to send the dealer information to the machine controller.

NOTE: Verify that all correct option and kits are selected before clicking **SEND TO MACHINE**.



Bobcat®

ENGINE INFORMATION (CONT'D)

Troubleshooting

The following troubleshooting chart is provided for assistance in locating and correcting problems which are most common. Many of the recommended procedures must be done by authorized Bobcat Service personnel only.

PROBLEM	CAUSE
Slow cranking speed	1, 2, 3, 4
Engine will not start	2, 5, 6, 7, 8, 9, 11, 12, 13, 14, 15, 16, 17, 19, 27, 28, 29
Difficult to start	5, 7, 8, 9, 10, 11, 12, 13, 15, 16, 17, 18, 19, 20, 25, 27, 28, 29
No power from engine	8, 9, 10, 11, 12, 13, 15, 16, 17, 21, 22, 24, 25, 26, 28, 29
Engine is mis-firing	8, 9, 11, 12, 13, 15, 16, 17, 21, 22, 24, 25, 26, 28
Too much fuel consumption	10, 12, 13, 15, 16, 17, 19, 20, 21, 23, 24, 25, 27, 28, 29
Black exhaust	10, 12, 13, 15, 16, 17, 19, 20, 21, 23, 24, 25, 27, 28, 29
Blue / white exhaust	4, 10, 15, 16, 17, 21, 23, 27, 29, 30, 50
Low oil pressure	4, 31, 32, 33, 34, 35, 37, 38, 39, 52
Engine knocking	13, 15, 16, 19, 22, 24, 25, 27, 29, 31, 40, 41, 53
Engine running rough	7, 8, 9, 10, 11, 12, 13, 17, 18, 22, 24, 25, 26, 29, 40, 53
Vibration	12, 13, 17, 21, 22, 25, 26, 29, 40, 42, 43
High oil pressure	4, 33, 36
Overheating	10, 12, 13, 15, 16, 20, 21, 40, 44, 45, 46, 47, 48, 51
Too much crankcase pressure	22, 27, 29, 30, 40, 49
Poor compression	10, 16, 21, 24, 25, 27, 28, 29, 30, 41, 53
Start and stop	9, 10, 11

KEY TO CORRECT THE CAUSE

1. Battery capacity low	28. Worn valves and seat
2. Bad electrical connections	29. Broken or worn piston rings
3. Faulty starter motor	30. Worn valve stems or guides
4. Incorrect grade of oil	31. Worn or damaged bearings
5. Low cranking speed	32. Not enough oil in the oil pan
6. Fuel tank empty	33. Switch is defective
7. Faulty stop control operation	34. Oil pump worn
8. Plugged fuel line	35. Relief valve is stuck open
9. Plugged fuel filter	36. Relief valve is stuck closed
10. Restriction in the air cleaner	37. Broken relief valve spring
11. Air in the fuel system	38. Faulty suction pipe
12. Faulty fuel injection pump	39. Plugged oil filter
13. Faulty fuel injectors	40. Piston seizure
14. Broken injection pump drive	41. Incorrect piston height
15. Incorrect injection pump timing	42. Faulty engine mounting
16. Incorrect valve timing	43. Incorrect alignment of flywheel
17. Poor compression	44. Faulty thermostat
18. Plugged fuel tank vent	45. Restriction in water jacket
19. Incorrect grade of fuel	46. Loose alternator belt
20. Exhaust pipe restriction	47. Plugged radiator
21. Cylinder head gasket leaking	48. Plugged breather pipe
22. Over heating	49. Plugged breather pipe
23. Cold running	50. Damaged valve stem oil deflectors
24. Incorrect tappet adjustment	51. Coolant level too low
25. Sticking valves	52. Plugged oil pump pipe strainer
26. Incorrect high pressure fuel lines	53. Broken valve spring
27. Worn cylinder bores	

ENGINE INFORMATION (CONT'D)

Compression-Checking

The tools listed will be needed to do the following procedure:

MEL10630 - Engine Compression Kit

MEL 1352 - Compression Adapter

The engine must be at operating temperature.

Remove the glow plugs.

Figure 70-10-33

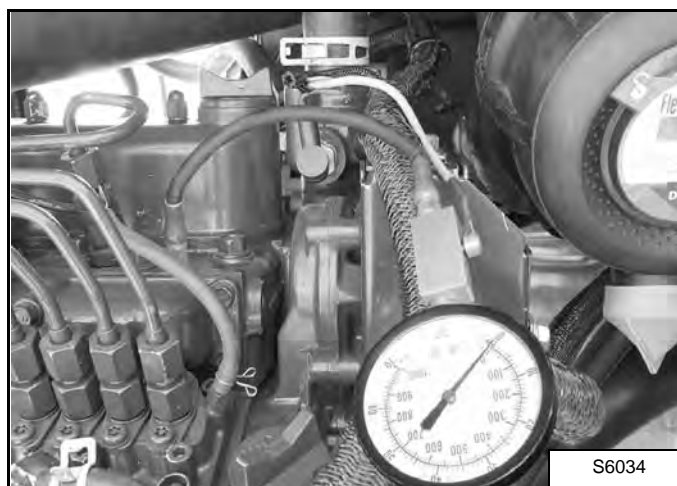

Install the correct compression adapter into the cylinder head **[Figure 70-10-33]**.

Connect the compression gauge **[Figure 70-10-33]**.

Make sure the speed control lever is at low engine idle.

Disconnect the fuel stop solenoid.

Crank the engine with the starter at 200-300 RPM.

Compression Pressure	412 - 469 PSI (28,4 - 32,3 bar)
Allowable Limit (minimum)	327 PSI (22,5 bar)

The compression must be no lower than the allowable limit, with no more than 10% variance among cylinders.

Connect the fuel stop solenoid.

ENGINE COOLING SYSTEM (CONT'D)

Testing The Thermostat

Figure 70-50-10

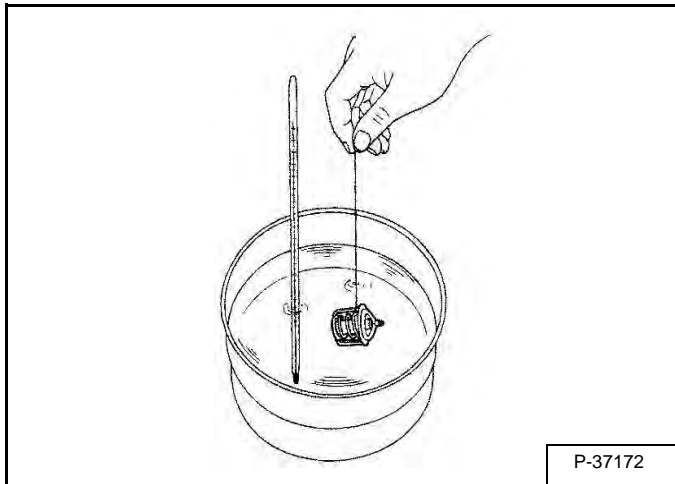

Hang the thermostats in a suitable container filled with coolant **[Figure 70-50-10]**.

Heat the coolant gradually. Use a thermometer to check the temperature when it starts to open and when it's fully open.

If the thermostats do not operate correctly they must be replaced.

FUEL SYSTEM (CONT'D)

Fuel Injection Pump Removal And Installation (Cont'd)

Figure 70-70-16

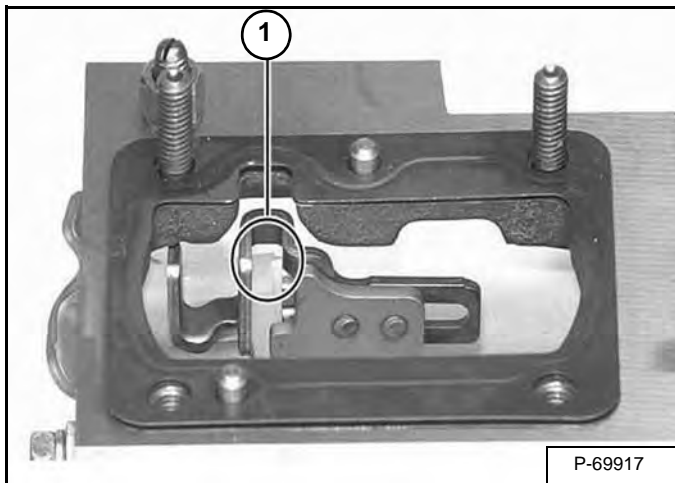

Installation: Use the same number of gasket shims, or new gasket shims with the same thickness.

Installation: When installing the injection pump, insert the control rack pin (Item 1) [Figure 70-70-15] firmly into the groove (Item 1) [Figure 70-70-16] of the fork thrust lever.

Timing The Injection Pump

! WARNING

AVOID INJURY OR DEATH

Diesel fuel or hydraulic fluid under pressure can penetrate skin or eyes, causing serious injury or death. Fluid leaks under pressure may not be visible. Use a piece of cardboard or wood to find leaks. Do not use your bare hand. Wear safety goggles. If fluid enters skin or eyes, get immediate medical attention from a physician familiar with this injury.

W-2072-0807

IMPORTANT

Do not bend the high pressure fuel injection tubes when removing or installing them.

I-2029-0289

Timing the injection pump is done by changing the number of shims between the injection pump and the injection pump mounting surface.

Remove the fuel lines and injectors.

Remove the fuel shutoff solenoid (See Fuel Shutoff Solenoid Removal And Installation on Page 70-70-3)

NOTE: The flywheel is rotated counter clockwise when standing at the flywheel end of the engine.

Figure 70-70-17

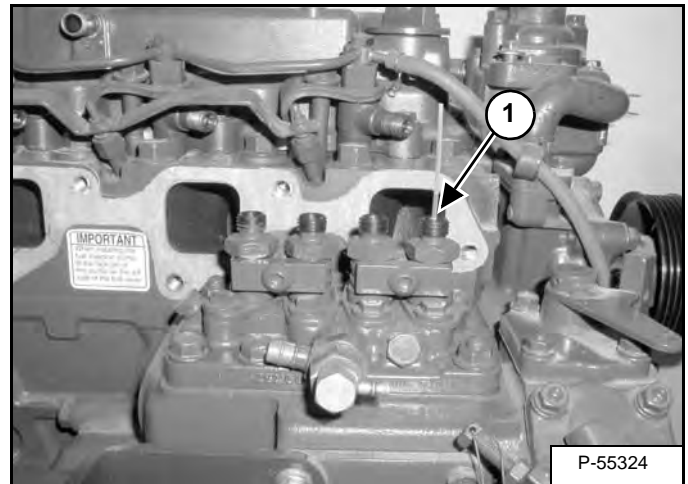

Install a short plastic tube (Item 1) [Figure 70-70-17] in the number one cylinder port of the injection pump. The tube should fit securely in the port and point upward.

Move the fuel lever on the injection pump to full fuel position (or full throttle).

Turn the engine counterclockwise until fuel flows out of the injection pumps number 1 cylinder nozzle. (Install a tool on the crankshaft at the front of the engine to turn the engine.)

NOTE: The fuel must flow out of the nozzle for one firing cycle before timing can be attempted.

Align the control rack pin (Item 1) with the notch (Item 2) and remove the pump (Item 3) [Figure 70-70-15].

Installation: Replace the manifold gasket if it is worn or damaged.

Remove the fuel shutoff solenoid.

CYLINDER HEAD (CONT'D)

Cylinder Head Removal And Installation

Figure 70-80-10

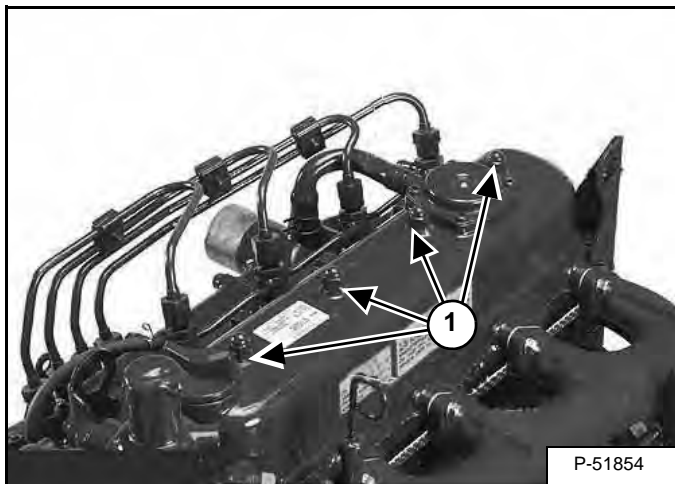

Remove the valve cover nuts (Item 1) [Figure 70-80-10].

Installation: Tighten the valve cover nuts to 5.1-8.3 ft.-lb. (6,9-11,3 N•m) torque.

Remove the valve cover and replace the gasket if needed.

Remove the fuel injector nozzles (See Fuel Injector Removal And Installation on Page 70-70-8)

Remove the glow plugs (See Glow Plug Removal And Installation on Page 70-80-2)

Figure 70-80-11

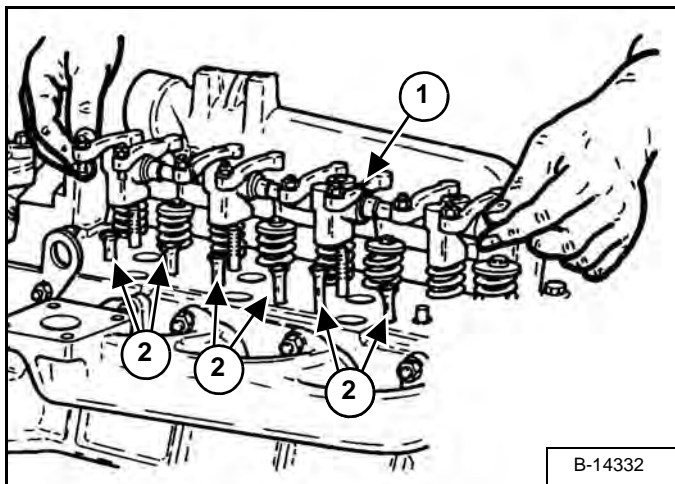

Remove the rocker arm and shaft assembly (Item 1) and the push rod tubes (Item 2) [Figure 70-80-11].

Installation: Tighten the nuts to 16-17 ft.-lb. (22-27 N•m) torque.

Figure 70-80-12

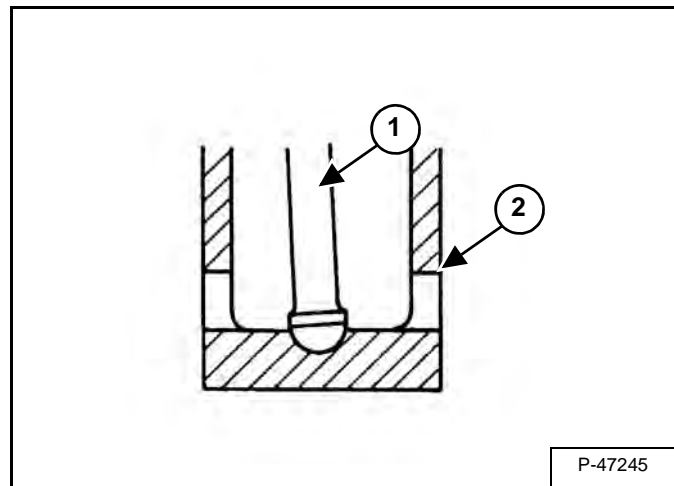

Installation: The push rod (Item 1) must be seated in the tappet (Item 2) [Figure 70-80-12] correctly or the push rods will be damaged.

After installing the rocker arm assembly and push rods, the valve lash must be adjusted.

Figure 70-80-13

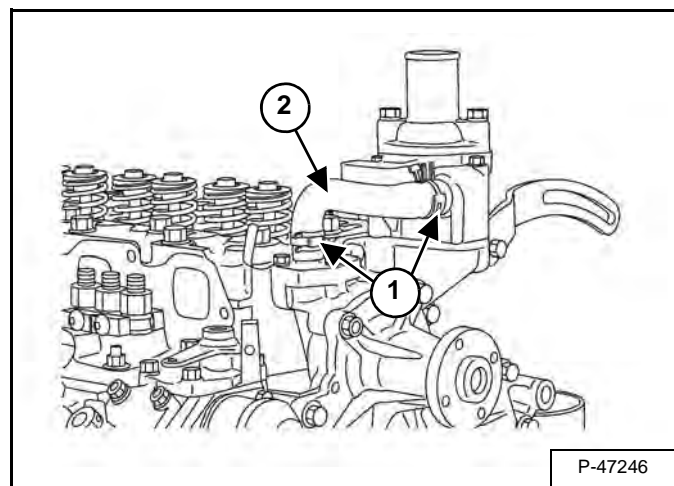

Remove the clamps (Item 1) and remove the hose (Item 2) [Figure 70-80-13] from the thermostat housing.

Remove the intake and exhaust manifolds.

CRANKSHAFT AND PISTONS (CONT'D)

Piston And Connecting Rod Removal And Installation (Cont'd)

NOTE: Mark the piston (Item 3) and connecting rod (Item 4) [Figure 70-90-3] with the same number to ensure correct installation and proper cylinder placement.

Figure 70-90-4

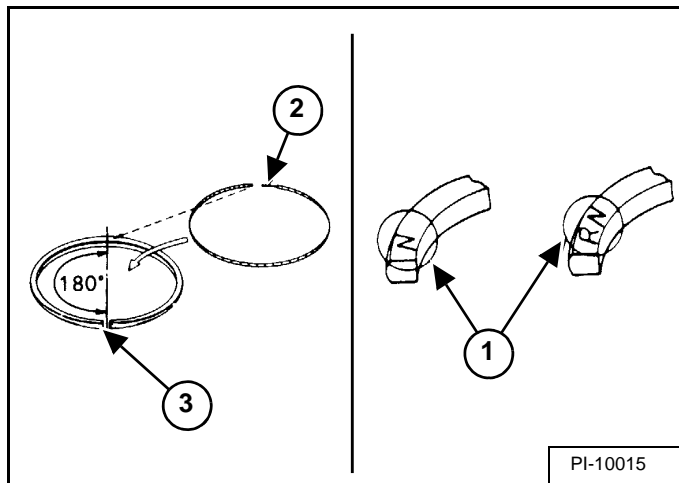

Installation: When installing new rings, assemble the ring so the mark (Item 1) near the gap faces the top of the piston. When installing the oil ring, place the expander joint (Item 2) on the opposite side of the oil ring gap (Item 3) [Figure 70-90-4].

Figure 70-90-5

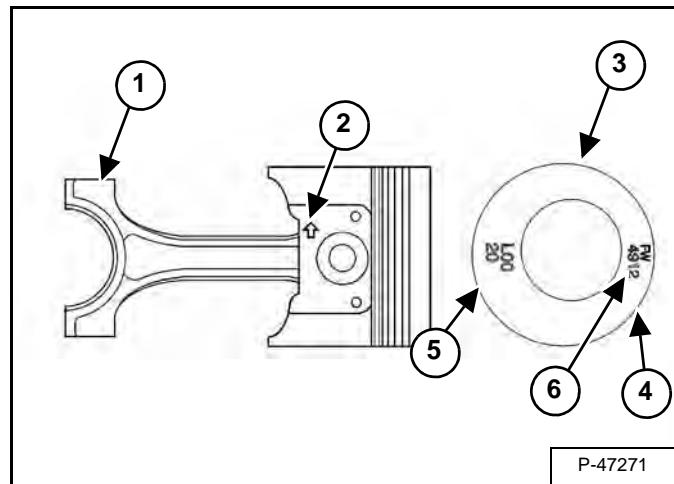

Installation: When reassembling, align the marks (Item 1) on the connecting rod and piston (Item 2). Heat the piston in clean engine oil to 176° F. (80° C.) and tap the piston pin into position. Place the piston rings so that there are gaps every 120° (Items 3, 4, and 5) [Figure 70-90-5] with no gap facing the piston pin in the cylinder.

NOTE: Assemble the piston to the connecting rod with the FW mark (Item 6) is facing the flywheel side and the connecting rod mark (Item 1) [Figure 70-90-5] facing the injection pump side.

CRANKSHAFT AND PISTONS (CONT'D)

Crankshaft And Bearings - Servicing (Cont'd)

Figure 70-90-35

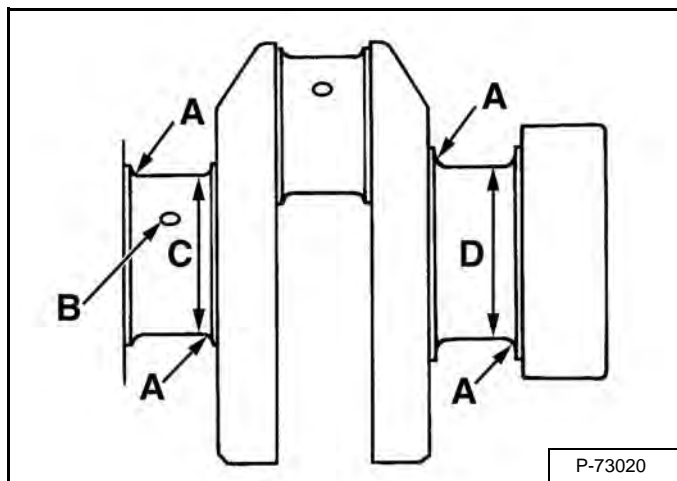

NOTE: Undersize dimensions of crankshaft journal [Figure 70-90-28].

Undersize	0.008 in. (0,2 mm)	0.016 in. (0,4 mm)
Dim. A	0.0906-0.1063 in. radius (2,3-2,7 mm) radius	0.0906-0.1063 in. radius (2,3-2,7 mm) radius
Dim. B	0.0394-0.0591 in. dia. (1,0-1,5 mm) dia.	0.0394-0.0591 in. dia. (1,0-1,5 mm) dia.
Dim. C	1.8793-1.8799 in. dia. (47,734- 47,750 mm) dia.	1.8714-1.8720 in. dia. (47,534- 47,550 mm) dia.
Dim. D	2.0362-2.0370 in. dia. (51,721- 51,740 mm) dia.	2.0284-2.291 in. dia. (51,521- 51,540 mm) dia.
The crankpin must be fine-finished to higher than (0.8-S)		



Bobcat®

TROUBLESHOOTING (CONT'D)

Engine Coolant Bypassing The Heater Valve

Figure 80-30-16

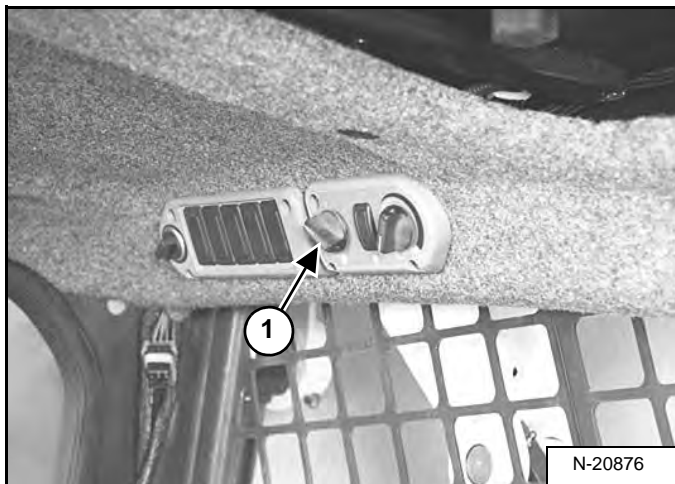

Raise the lift arms and install an approved lift arm support device (See LIFT ARM SUPPORT DEVICE on Page 10-20-1.)

Turn the fan switch (Item 1) [Figure 80-30-16] to the High Speed position, with the loader ignition switch OFF.

Raise the operator cab. (See Raising on Page 10-30-1.)

Figure 80-30-17

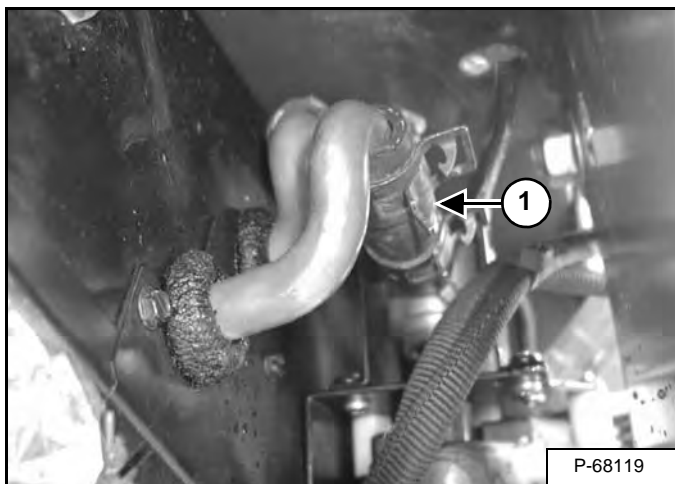

Connect the remote start tool to the loader. (See Remote Start Procedure on Page 10-60-4.)

Start the loader and run at high idle, for ten minutes.

Check the heater hose (Item 1) [Figure 80-30-17] for temperature.

If the hose is hot, the heater valve is leaking by, and needs to be replaced.

Heater Valve Not Opening Or Closing

Figure 80-30-18

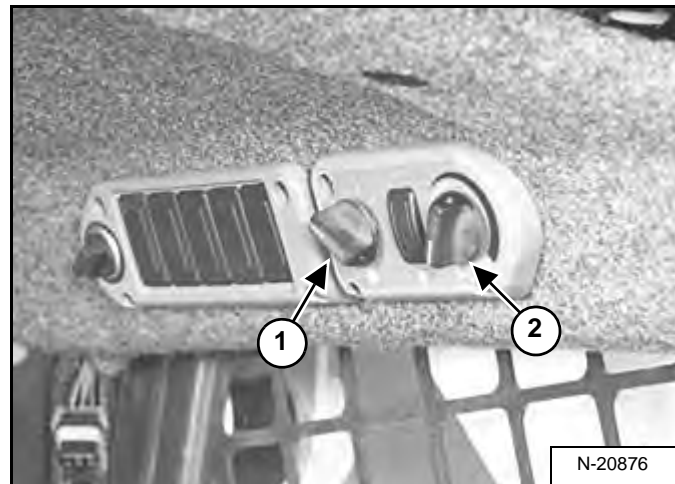

Raise the lift arms and install an approved lift arm support device (See LIFT ARM SUPPORT DEVICE on Page 10-20-1.)

Turn the fan switch (Item 1) to position 1. Turn the temperature control (Item 2) [Figure 80-30-18] to the High cold position, with the loader ignition switch OFF.

Raise the operator cab. (See Raising on Page 10-30-1.)

Connect the remote start tool to the loader. (See Remote Start Procedure on Page 10-60-4.)

Figure 80-30-19

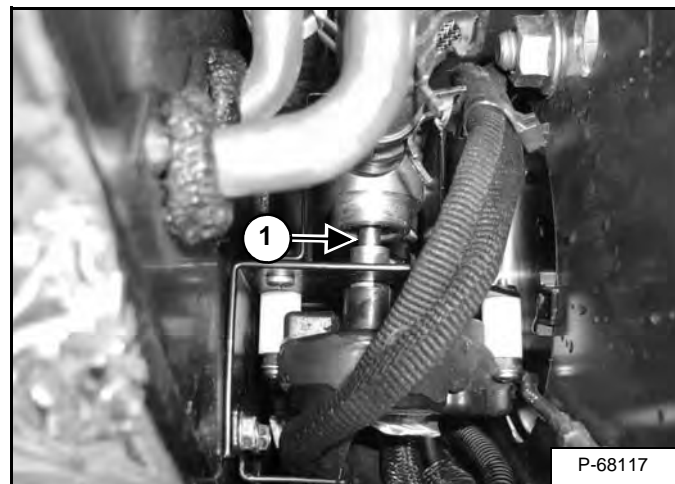

Place the remote start tool on the left fender of the loader, so the heater valve can be clearly seen. Watch the valve shaft (Item 1) [Figure 80-30-19], as the key of the remote start tool is turned to the ON position without starting the loader. The heater valve should rotate. Place a mark on the heater valve shaft.

HEATER FAN (CONT'D)

Connector Identification

Figure 80-60-12

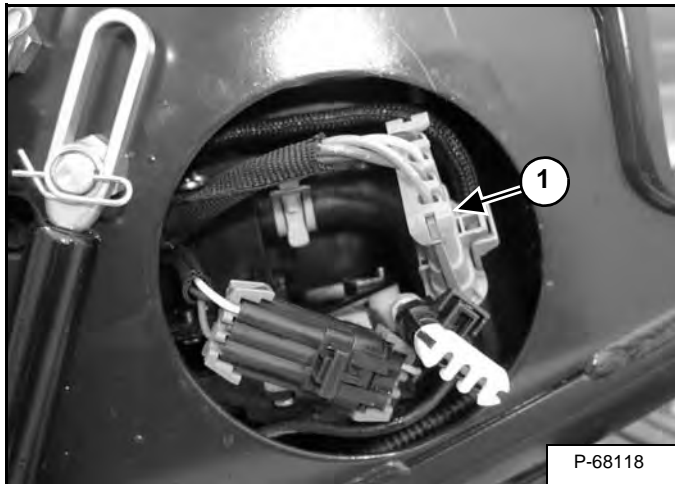

The wiring code for the blower fan connector [Figure 80-60-12] is:

Number on Connector	Wire Color
1	Orange
2	Red
3	Yellow
4	Black

Reverse the removal procedure to install the wire connector.

LOADER SPECIFICATIONS (CONT'D)

Instrumentation

The following loader functions are monitored by a combination of gauges and warning lights in the operator's line of sight. The system alerts the operator of monitored loader malfunctions by way of audible alarm and visual warning lights.

Standard Instrument Panel

- Gauges
 - Engine coolant temperature
 - Fuel
 - Hour-meter
- Indicators
 - Bobcat Interlock Control System
 - Glow plugs
- Warning lights
 - Engine coolant temperature
 - Engine oil pressure
 - Fuel level
 - General warning
 - Hydraulic filter
 - Hydraulic oil temperature
 - Hydrostatic charge pressure
 - Seat belt
 - System voltage

CLICK HERE TO **DOWNLOAD** THE COMPLETE MANUAL

- Thank you very much for reading the preview of the manual.
- You can download the complete manual from: www.heydownloads.com by clicking the link below



- Please note: If there is no response to CLICKING the link, please download this PDF first and then click on it.

CLICK HERE TO **DOWNLOAD** THE COMPLETE MANUAL